



FOR RELEASE: SUNDAY
June 26, 1966

RELEASE NO: 66-157

PROJECT: Saturn/Apollo Uprated Saturn I
(Second Mission)

(To be launched no earlier
than June 29, 1966)

CONTENTS

GENERAL RELEASE-----1-4
FLIGHT SEQUENCE-----5-6
AS-203 LAUNCH VEHICLE OPERATIONAL FLIGHT
TRAJECTORY NOMINAL SEQUENCE OF EVENTS-----6-7
ORBITAL VENTING IMPULSE-----8-10
EXPERIMENT CONTROL-----10-12
UPRATED SATURN I LAUNCH VEHICLE-----12
 S-IB Stage-----12-13
 S-IVB Stage-----13-14
 Instrument Unit-----15
 Nose Cone-----15
PRELAUNCH CHECKOUT AND COUNTDOWN-----16-17
LAUNCH COMPLEX 37-----17
MISSION OBJECTIVES-----18-19
 Secondary-----20
SUBCRITICAL CRYOGENIC EXPERIMENT-----21
INSTRUMENTATION AND DATA ACQUISITION-----22
 Second Stage Instrumentation-----22-24
 Special First Stage Instrumentation-----24
 Instrumentation by Unit-----25
 Ground Network-----26
LIQUID HYDROGEN EXPERIMENT-----27-28

P
R
E
S
S

K
I
T

N66 31849

FACILITY FORM 602

(ACCESSION NUMBER)	(THRU)
38	1
(PAGES)	(CODE)
	31
(NASA CR OR TMX OR AD NUMBER)	(CATEGORY)

FOR RELEASE: SUNDAY
June 26, 1966

RELEASE NO: 66-157

**SECOND UNMANNED
APOLLO MISSION
A UNIQUE STUDY**

(THE TWO-STAGE UPRATED SATURN I LAUNCH VEHICLE, FORMERLY DESIGNATED THE SATURN IB, CONSISTS OF THE IB FIRST STAGE AND THE IVB UPPER STAGE. THE IVB STAGE IS A COMPONENT OF THE APOLLO PROJECT'S SATURN V ROCKET WHICH WILL LAUNCH AMERICAN ASTRONAUTS ON THE FIRST MANNED MOON LANDING MISSION LATE IN THIS DECADE.)

The second Saturn/Apollo Uprated Saturn I launch development mission, to be launched at Cape Kennedy no earlier than June 29, is a unique engineering study of liquid hydrogen fuel behavior during orbital flight.

Primary purpose of the unmanned mission is observing operation of the two-stage launch vehicle's S-IVB second stage prior to its use as a stage of Saturn V rockets in the National Aeronautics and Space Administration's manned lunar landing program.

The Uprated Saturn I will not carry an Apollo spacecraft. Instead, the vehicle's second stage, an instrument unit and a nose cone will orbit as one body, 92 feet long. It will weigh 58,500 pounds, the heaviest U.S. satellite ever placed in orbit.

-more-

6/21/66

It will orbit the Earth once every 88 minutes with the satellite U.S. inclined to the Equator about 32 degrees. No recovery is planned.

The vehicle will stand 173 feet high on Launch Complex 37 and its liftoff weight will be 1,187,000 lbs.

The liquid hydrogen studies involving the second stage will be carried out for three or four orbits. Approximately 10 tons of liquid hydrogen will remain in the stage after insertion into orbit.

Hydrogen is a very efficient fuel. However its behavior in this large a volume in outer space has not been observed. NASA engineers believe that the techniques devised to handle the very cold (minus 423 degrees F. is its boiling point) and very light (the hydrogen atom is the lightest known) fluid are sufficient, but the only way to verify this is to conduct an orbital experiment such as this.

The information to be derived is necessary not only to the Apollo lunar landing program but also to overall launch vehicle development. Hydrogen is about 40 per cent more powerful than the conventional kerosene fuels used in Saturn boosters.

The S-IVB stage serves as the top stage of both the up-rated Saturn I and the larger Saturn V launch vehicles. In its Saturn V use, the stage will be required to operate in orbit preparatory to departing for the Moon. This will include an orbital restart of its main propulsion system following a coast period of up to four-and-one-half hours (three orbits).

Techniques for managing propellants during this critical time--including propellant tank venting, the settling of propellants to the bottom of tanks through the continuous use of forward thrust, and engine chilldown in preparation for restart--must be tested in Earth orbit since no conclusive data on the use of large masses of hydrogen in orbit is obtainable in any other way.

In addition to propellant studies, an experiment concerning the storage of cryogenic (extremely low temperature) fluids will be carried in the Saturn nosecone. A sphere containing liquid nitrogen will test a storage system applicable to fuel cell development. Liquid nitrogen readily simulates liquid oxygen used in fuel cells and it is much easier and safer to test.

The NASA Marshall Space Flight Center at Huntsville, Ala., is responsible for development and testing the Saturn vehicle. The first stage, developing 1.6 million pounds thrust from eight Rocketdyne H-1 engines, is made by the Chrysler Corp. at MSFC's Michoud Assembly Facility in New Orleans. Douglas Aircraft Co. builds the second stage, powered by one Rocketdyne J-2 engine developing 200,000 pounds thrust, at Huntington Beach, Calif. The instrument unit is assembled by International Business Machines Corp. at Huntsville. The Marshall Center made the nose cone and devised the liquid hydrogen tests for this mission.

The NASA John F. Kennedy Space Center, Fla. is responsible for checkout and launch.

The cryogenic storage experiment is provided by the NASA Manned Spacecraft Center, Houston.

All of the work is under the direction of the Office of Manned Space Flight, NASA Headquarters, Washington, D.C., headed by Dr. George E. Mueller, Associate Administrator, OMSF.

(END OF GENERAL RELEASE; BACKGROUND INFORMATION FOLLOWS.)

FLIGHT SEQUENCE

Ten seconds after liftoff, the vehicle will begin to roll into its flight azimuth of 72 degrees east of north. Mach one velocity will be reached at 52 seconds after liftoff (T+52). At T+69 seconds, the vehicle will pass through the area of maximum dynamic pressure. This will occur at about 7.8 miles altitude.

The pitch program, which will have begun at T+10 seconds, will be ended at T+134 seconds. The first stage's four in-board engines will cut off at T+139 seconds. The outboard engines will cease three seconds later, at T+142. The rocket's position at that point: 59 miles range, 40 miles altitude and traveling at 6,016 statute miles per hour.

During the next two seconds the following events occur in this order: second stage ullage rockets ignite to settle propellants; the two stages separate; first stage retrorockets located on interstage adapter fire; second stage main engine ignites; ullage rockets cease at T+147 and they are jettisoned eight seconds later.

Path adaptive guidance is initiated at T+157 seconds. The second stage cutoff should occur at T+435 seconds and the vehicle will be considered to be in orbit ten seconds later, at which point it will be 880 miles downrange at an altitude of 118 statute miles and traveling at 17,432 miles per hour. Orbital period will be 88 minutes inclined 31.98 degrees to the Equator. All essential engineering tests are to be conducted during the first three orbits. If the second stage is still performing satisfactorily additional activities are planned during the fourth orbit.

Total weight in orbit will be 58,537, including about 19,000 pounds of hydrogen for the propellant studies, which will be reduced by about 20 per cent during four orbits. The weight breakdown is as follows:

Nose cone	3,707
Instrument unit	4,568
S-IVB dry weight	24,853
Excess LOX in tank (useable)	3,719
Excess LH ₂ in tank (useable)	18,475
LOX flt. performance reserve	664
LH ₂ flt. performance reserve	133
LOX residuals (trapped)	651
LH ₂ residuals (trapped)	553
GOX (gaseous oxygen)	554
H ₂ gas (gaseous hydrogen)	270
Auxilliary propellant	130
Service items	260
Injection weight	<u>58,537</u>

AS-203 LAUNCH VEHICLE OPERATIONAL FLIGHT TRAJECTORY
NOMINAL SEQUENCE OF EVENTS

NOMINAL TIME FROM FIRST MOTION (Min:Sec) (Sec)		PREDICTED SEQUENCE
-0:05.0	-5.0	Guidance reference release
-0:03.1	-3.1	S-IB mainstage ignition sequence begins
0:00.0	0.0	First motion
0:00.2	0.2	Liftoff signal
0:06.9	6.9	Tower cleared
0:10.2	10.2	Pitch and roll maneuver initiated
0:28.2	28.2	Roll maneuver to obtain 72 degrees flight azimuth completed
0:52.0	52.0	Mach number = 1.0
1:09.0	69.0	Maximun dynamic pressure
2:14.0	134.0	Pitch tilt arrest
2:16.6	136.8	S-IB propellant level sensor actuation

NOMINAL TIME FROM FIRST MOTION (Min:Sec)	(Sec)	PREDICTED SEQUENCE
2:19.8	139.8	Inboard engine cutoff
2:21:8	141.8	Outboard engine thrust O.K.; switches electrically inter- connected
2:22.8	142.8	Outboard engine cutoff
2:23.4	143.4	Ullage rocket ignition
2:23.6	143.6	Fire separation device and com- mand retrorocket ignition
2:23.7	143.7	Separation completed
2:25.1	145.1	S-IVB engine start command
2:28.9	148.9	S-IVB main stage 90% thrust level
2:36.1	156.1	Jettison ullage rocket motors
2:37.0	157.0	Initiate active guidance
7:15.6	435.6	S-IVB guidance cutoff signal
7:15.84	435.84	LVDC Issues TB4 & Redundant cutoff signal
7:25.6	445.6	S-IVB Orbital Insertion

ORBITAL VENTING IMPULSE

TIME (from second stage cutoff, liftoff plus 435.5 seconds)			EVENT	TOTAL THRUST (Pounds)	
Hour	Minute	Second			
1.	00	00	00.2	LOX Ullage vent open	34.1
2.	00	00	55.2	LH ₂ Continuous vent open	45.5
3.	00	01	20.2	LOX Ullage vent closed	11.4
4.	01	24	45.5	LOX Ullage vent open	36.4
5.	01	25	06.5	LH ₂ Continuous vent closed	25.
6.	01	30	59.8	J-2 fuel lead command on	922.
7.	01	31	11.1	LH ₂ continuous vent open	932.8
8.	01	31	12.3	J-2 Fuel lead command off	35.8
9.	01	31	37.5	LOX Ullage vent closed	10.8
10.	03	00	04.2	LH ₂ Continuous vent closed	0.0
11.	03	05	07.0	LOX Ullage vent open	17.1
12.	03	06	45.7	LH ₂ Continuous vent open	22.7
13.	03	07	09.7	LOX Ullage vent closed	5.6
14.	03	51	10.5	LOX Ullage vent open	19.5
15.	03	54	01.5	LOX Ullage vent closed	5.6
16.	04	37	18.5	LOX Ullage vent open	14.7
17.	04	37	38.5	LH ₂ Continuous vent closed	9.1
18.	05	16	50.0	Change in Ullage LOX vent	3.5
19.	06	10	23.5	LOX Ullage vent closed	0.0

The orbital Impulse Chart represents the ideal case. If all systems work exactly as expected and if design assumptions are accurate, the orbital functions will be carried out in this manner. Ground controllers have the capability of varying these actions.

Soon after the second stage cutoff the LOX and then the LH₂ continuous vent valves will be opened, the first of many manipulations of those systems during the experiment.

Referring to the Impulse Chart, the following explanations are offered: Step five, at the end of the first orbit, refers to preparations for engine restart, although as previously noted the restart preparations carried out will end just short of actual reignition. As a step leading to this, LOX tank venting, simulating the Gemini-type ullage engines of the Saturn V S-IVB, is initiated in Step 4. Hydrogen tank repressurization takes place, using helium, although less than full operational pressure is reached. Chardown of plumbing and turbomachinery takes place between Steps 5 and 6. (During the next orbit only the fuel system will be chilled down.) The hydrogen used for this purpose is recirculated into the hydrogen tank. But the hydrogen used for chilling the engine itself is not recirculated. It is expelled through the engine nozzle and causes a great increase in the amount of thrust at Step 6.

At the end of the second orbit, a second restart sequence will be initiated, involving the chardown of lines and turbomachinery, but this time it will be done without repressurization of the hydrogen tank by the stage pressurization system. Also it will be done without benefit of the ullage venting of the LOX tank. This exercise, then depends totally on the hydrogen continuous venting system to keep the propellants seated, which is another attempt to see how effective the system is, although it is not expected to be taxed to this degree during Saturn V missions.

Immediately following this, for five minutes (Step 10) the stage is under no acceleration at all. Both the hydrogen and the oxygen vent systems are inoperative and the stage is under zero gravity for the only time during the mission. This is to see how the gas and liquid react to the absence of induced forward motion, and to see how effective LOX venting alone (Step 11) is in settling the propellant after five minutes of weightlessness.

Near the end of the third orbit, and at the beginning of the fourth, once over Carnarvon and twice over the U.S., rapid depressurization of the hydrogen tank will occur. These "blow-downs" will occur through the non-propulsive venting system of the S-IVB stage. The first time it will be done with ullage thrusting from the LOX tank; the second and third times will be without ullage thrusting. These experiments will simulate venting rates that could be encountered during cyclic venting, which is an alternate venting scheme that could be used in case of failure of the continuous vent system.

This rapid depressurization will create a condition similar to the "spewing" or boilover that results from shaking a carbonated beverage. Gas and fluid will be vented rapidly--much more liquid will be lost in this method of venting.

The TV system will monitor the behavior of the propellant and the quality meter (see page) will have the important role of determining the percentages of liquid and gas lost in these actions.

As the fourth orbit begins, the oxygen ullage system becomes operative to determine its effectiveness in settling the tank following such major disturbances. This experiment, the last, continues for the next orbit.

EXPERIMENT CONTROL

An important aspect of the flight will be the continuous monitoring of the liquid hydrogen with television cameras mounted in the forward end of the liquid hydrogen tank.

Engineers especially placed at four remote tracking sites will gather information in "real time" to assist in making decisions relating to the experiment. Stations receiving the television signal are Cape Kennedy, Corpus Christi, Texas; Bermuda, and Carnarvon, Australia. Signals from the Corpus Christi and Cape Kennedy stations will be relayed directly to MSC, Houston and the Huntsville Operations Support Center for projection to mission control and support engineers.

An experiment systems engineer's representative (ESER) will have one of the most important decision-making positions in the net.

The S-IVB stage will be placed into orbit over Bermuda about $7\frac{1}{2}$ minutes after launch. The engineer there will monitor the liquid hydrogen behavior on his television screen to determine if the fluid is stable and he will also keep an eye on instruments indicating the opening of certain valves. With split-second accuracy he must decide and recommend to the mission control what action should be taken.

During the short time the stage is in the range of the Bermuda station, the ESER may recommend the initiation of two of five alternate sequences designed to correct failures.

If the liquid oxygen ullage thrust control valve fails to open on command soon after S-IVB cutoff, the Bermuda engineer may recommend initiating J-2 engine fuel lead. Here fuel will be run through the engine to provide additional thrust. This sequence should occur 10-20 seconds after engine cutoff.

Insufficient settling of propellants determined by observation of liquid motion through the TV system $1\frac{1}{2}$ minutes after S-IVB cutoff will require the use of another alternate sequence. Here if the gaseous oxygen thrusters do not achieve the settling required in 77 seconds of operation, the Bermuda station may call for them to continue operation for 70 seconds more.

Another vital operation should occur between 56 seconds and 76 seconds after J-2 engine cutoff. Should there be a failure of the liquid hydrogen tank continuous vent valve to open, then the non-propulsive vent valve will be opened to allow a pressure drop in the tank. After the pressure has been reduced to some 15-20 psi another attempt will be made to open the continuous vent valve. The same sequence could occur at one hour and 31 minutes and at three hours and seven minutes after engine cutoff. These are the only alternate sequences which may occur after the first orbit.

When the S-IVB stage is over Texas during the first orbit, the automatic sequence calls for the liquid oxygen ullage thrust control valves to open. After opening, normal procedure is for the hydrogen and liquid oxygen pumps to run for 330 seconds in the first engine chilldown and then cut off. This is to be followed by a $12\frac{1}{2}$ -second fuel lead on the J-2 engine. After the J-2 engine shuts off, the liquid oxygen ullage thrusters close and the continuous vent valve opens.

If the ground control team desires, commands can be sent to bypass the LOX chilldown, stop the LOX pump after it starts, and/or shut off the pump if a problem should occur after it starts. The liquid oxygen chilldown is in the automatic sequence and will occur unless it is deleted or stopped.

THE UPDATED SATURN I LAUNCH VEHICLE

The development of the updated Saturn I was started in mid-1962, soon after the Apollo program established the need of a medium capability vehicle -- more powerful than the Saturn I -- for Apollo spacecraft testing in Earth orbit prior to Saturn V flights. The vehicle would use the first stage of Saturn I, with state-of-the-art improvements, the third stage and instrument unit of the Saturn V, and the manufacturing, testing and other facilities available through both programs.

The first Updated Saturn I mission on February 26, 1966 was a success which continued a string of 10 perfect flights of the basic Saturn I vehicle.

Development of the second stage, the S-IVB, was speeded by the technology gained during development of the Saturn I second stage, the S-IV. Also, the instrument unit for updated Saturn I and Saturn V was a direct outgrowth of the Saturn I instrument unit.

S-IB Stage

The updated Saturn I booster (S-IB) has been changed in a number of ways in comparison with the standard Saturn I first stage. Most of the changes are engineering modifications to reduce weight. Changes in the new booster include: weight reduced by about 20,000 pounds, propellant container redesigned, barrel assembly redesigned, outriggers redesigned, outboard engine skirts removed and the gaseous oxygen (GOX) interconnect and vent system redesigned. The first of these redesigned boosters is being flown as a part of AS-203. (The first two boosters in this series were initially designated a part of the Saturn I program and some of the weight-reducing changes were not incorporated in them.)

The first stage is 80.2 feet long and 21.4 feet in diameter. It is a combination of nine propellant tanks, eight H-1 engines, eight fin assemblies and various control systems, structural assemblies and instrumentation. Eight of the propellant tanks are 70 inches in diameter, and the ninth is 105 inches in diameter. The eight smaller tanks are clustered about the large center tank. The center tank and four outer tanks contain liquid oxygen. The other four outer tanks, assembled alternately between oxygen tanks, contain the rocket's RP-1 (kerosene) fuel. The tanks are interconnected to equalize tank pressure, assure uniform flow of fuel and oxidizer to the eight engines and to provide the capability of diverting propellants to other engines in the event one or more engines fail.

The H-1 engines produce 200,000 pounds thrust. The cluster of eight gives the first stage a total thrust of 1.6 million pounds for about 2½ minutes. During this boost phase, the engines consume about 40,000 gallons (267 pounds) of RP-1 fuel and 64,500 gallons (615,000 pounds) of liquid oxygen in reaching an altitude of about 40 miles before engine cutoff. The four inboard engines are mounted rigidly in a square pattern around the center point on the aft end of the thrust structure. The other four engines, also arranged in a square, are mounted near the outer edge of the thrust structure. The outer engines are equipped with independent, closed-loop hydraulic systems which gimbal the engines as much as eight degrees for vehicle flight direction control.

The eight fins, spaced equally around the tail unit assembly, increase aerodynamic stability in the lower atmosphere. They also provide vehicle tiedown points and support the vehicle on the launch pad.

Miscellaneous equipment includes a control pressure system, purge system, a fire detection and water quench system, a flight termination system, electrical power supply and distribution, recoverable cameras, instrumentation and telemetry systems.

The interstage structure remains attached to the first stage at separation of stages, providing first stage deceleration by retrorockets and reducing the mass that the second stage must accelerate during powered flight.

The Chrysler Corp. produces the first stages at the Marshall Center's Michoud Assembly Facility in New Orleans. Rocketdyne Division of North American Aviation makes the engines. Completed stages are sent by barge to the Marshall Center at Huntsville, Ala. for static firing. They are then returned by barge to Michoud for refurbishment and checkout and transported to Kennedy Space Center, Fla. from New Orleans by sea-going barge.

S-IVB STAGE

The second stage of the uprated Saturn I, the S-IVB, will also serve as the third stage of the Saturn V which will launch the Apollo spacecraft to the Moon. On the uprated Saturn I, the stage provides the velocity increase after first stage separation to place the Apollo spacecraft into Earth orbit. On this flight, the S-IVB will go into orbit with the IU and nose cone instead of with an Apollo. The liquid hydrogen experiment will be performed with the S-IVB.

APOLLO/SATURN 203

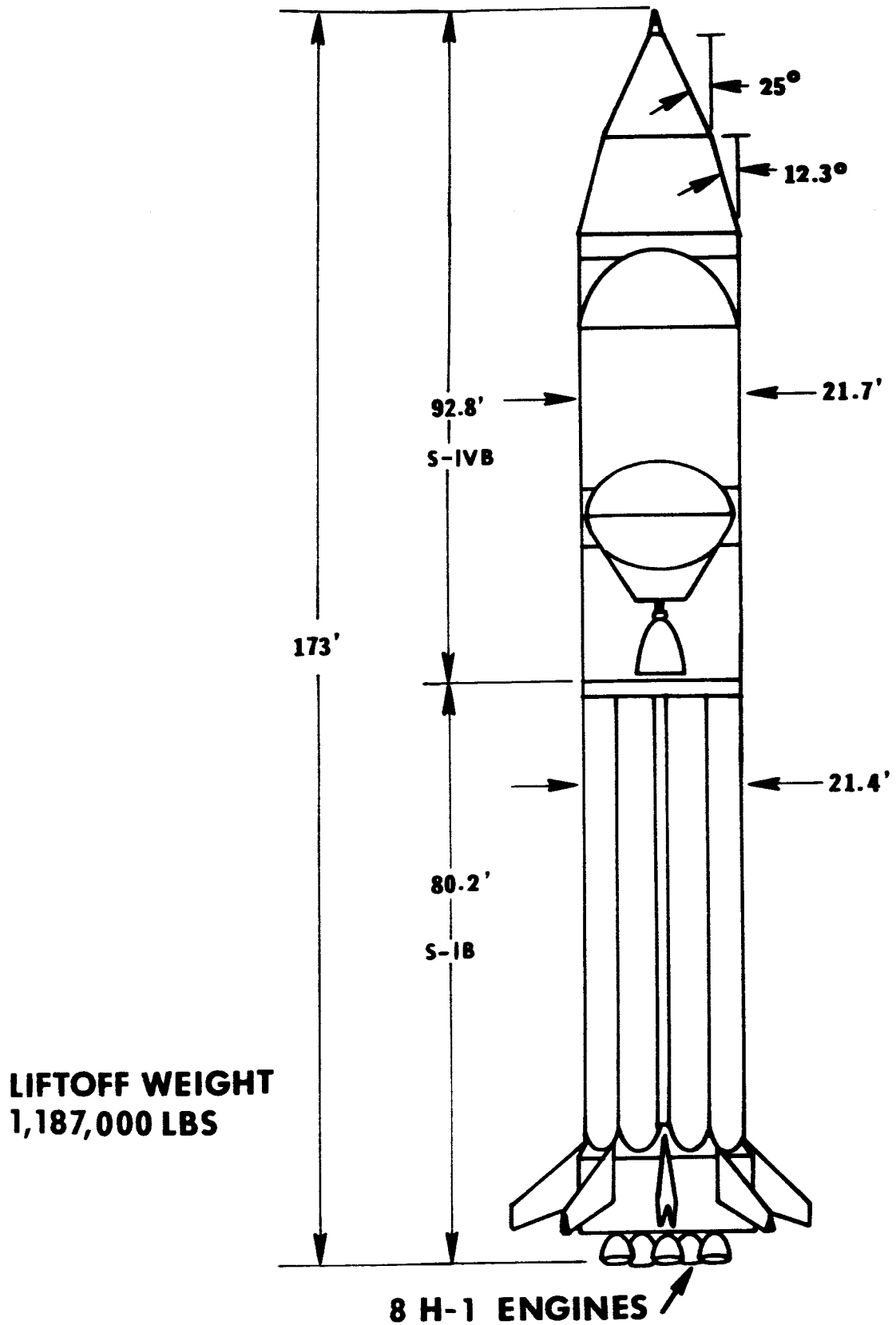

The S-IVB is manufactured by Douglas Aircraft Co. under the direction of the Marshall Center. It is 58.4 feet long and 21.7 feet in diameter. Dry weight of the stage is about 29,700 pounds, including the interstage adapter. It is powered by one J-2 engine, also manufactured by Rocketdyne, which develops 200,000 pounds of thrust. To achieve orbital speed and altitude in a normal mission, the stage operates about 7.5 minutes, burning about 64,000 gallons (38,000 pounds) of liquid hydrogen and 20,000 gallons (191,000 pounds) of liquid oxygen.

Static testing of the S-IVB is conducted at the Douglas Test Center at Sacramento, Calif. Following testing, the stage is transported by the Super Guppy aircraft to the Kennedy Space Center.

The S-IVB consists of a forward skirt, a propellant tank with a common bulkhead to separate the liquid hydrogen from the liquid oxygen, and aft skirt, thrust structure, after interstage assemblies, J-2 engine, and Auxiliary Propulsion System (APS), propellant utilization system, stage separation system and ordnance systems. Items mounted on the exterior of the stage include two range safety antennas, four telemetry antennas, three ullage rockets, two APS modules and various equipment tunnels and fairings.

The APS provides attitude control for the stage and payload during powered and coast flight. During powered flight, the APS provides only roll control but during coast it provides pitch, yaw and roll control. Each of the two 80-inch long aerodynamically shaped modules, mounted 180 degrees apart on the aft skirt, contains three liquid propellant 150-pound thrust engines, a fuel and oxidizer storage and supply system, a high pressure helium storage and regulation system and control components for preflight servicing and inflight operation. The engines use the hypergolic combination of nitrogen tetroxide as the oxidizer and monomethylhydrazine as the fuel, eliminating the need for an ignition system.

Instrument Unit

The instrument unit (IU) is the "brain" of the vehicle. It houses electrical and mechanical equipment that guides, controls and monitors vehicle performance from liftoff until after insertion of the payload into orbit. It controls first stage powered flight, stage separation, second stage powered flight, injection into Earth orbit and Earth orbital stabilization. Equipment in the IU includes: guidance and control; electrical; measurement and telemetry; radio frequency; instrumentation; range safety command system; environmental control; and emergency detection systems (EDS). A "ring" the same diameter as the S-IVB stage, the IU is three feet high and weighs about 4,600 pounds. It is an unpressurized, load-supporting structure of sandwich-type bonded construction. Honeycomb-panel "cold plates" are attached to welded brackets on the interior skin of the IU. The electrical and electronic equipment is mounted on the cold plates.

The IU was designed by the Marshall Center. International Business Machines Corp., Federal Systems Division, is the contractor for fabrication, system testing, and integration and checkout with the launch vehicle.

Nose Cone

The nose cone for AS-203 mission is a semimonocoque skin and stringer structure of double-angle configuration, that is, it tapers at two points. The nose cone is 21.7 feet in diameter at the base and 28 feet high. Bolted to the top edge of the IU, it will not be separated from the second stage and IU during flight.

The cone contains equipment for evaluating the structure and for testing an experimental cryogenic storage system designed by the NASA Manned Spacecraft Center. (See page for details on the experiment.)

APOLLO/SATURN 203 NOSECONE

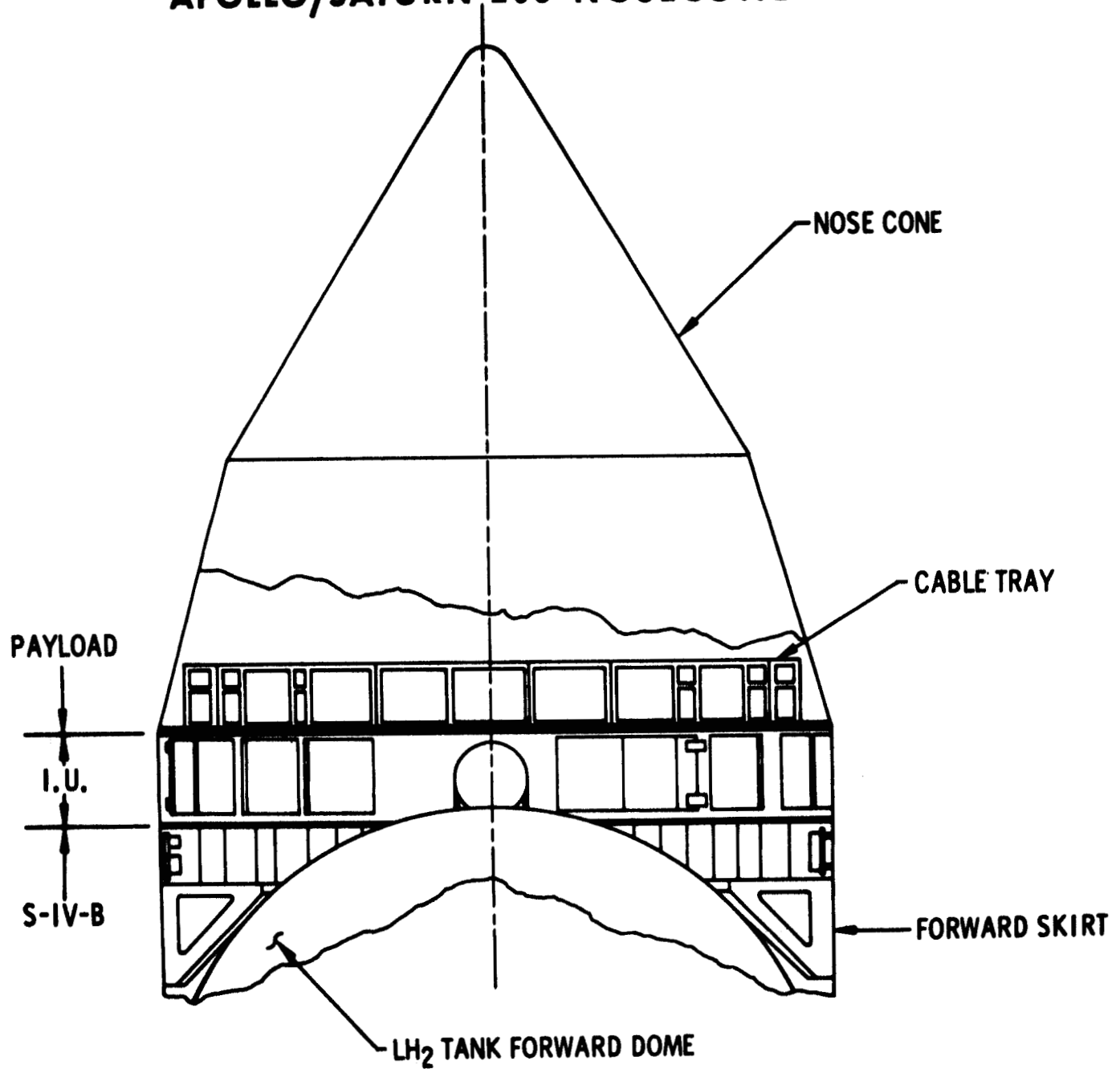

PRELAUNCH CHECKOUT AND COUNTDOWN

The major components of the launch vehicle arrived at the NASA Kennedy Space Center (KSC) in April. The first stage was brought in by the NASA barge, Promise, and second stage and instrument unit by aircraft, Super Guppy. The nose cone was brought to KSC by another barge, Poseidon, in March. After inspection, the two stages and the instrument unit were taken to Launch Complex 37 and erected. The nose cone was mated to the vehicle the last week in April. Combined system testing of the integrated vehicle was begun and a flight readiness review will be held about one week before launch.

This will be followed by a countdown demonstration in which the entire 26-hour 15-minute countdown is rehearsed, short of actual engine ignition. During the demonstration both stages of the launch vehicle were fueled.

A step toward complete automatic checkout, which will probably reach fruition in the Apollo/Saturn V program, was made during the pre-launch phase of the A/S 203 mission. Two computers--RCA 110A's-- are utilized in the automatic checkout procedures. One is located in the blockhouse at Complex 37, the other in the base of the launch pad.

Automatic checkout in the Saturn IB program has been progressive, involving more and more individual subsystems as the level of confidence increased.

The countdown for A/S 203 will start a full day prior to actual liftoff. The first part will end at T-11 hours and 15 minutes, with a built-in hold. Ignition occurs at T-3 seconds. During the first part of the count, for a period of about 15 hours, ordnance items will be installed and continuous mechanical and propulsion system checks will be made. The second phase of the countdown continues the propulsion system and mechanical checks but is expanded to include such items as guidance and control, radio frequency and telemetry, power transfer, range safety, and propellant loading.

The first stage will have 22 per cent of its liquid oxygen oxidizer loaded aboard at T-5 hours, reaching full capacity about three hours from liftoff.

APOLLO/SATURN 203 FIRST STAGE

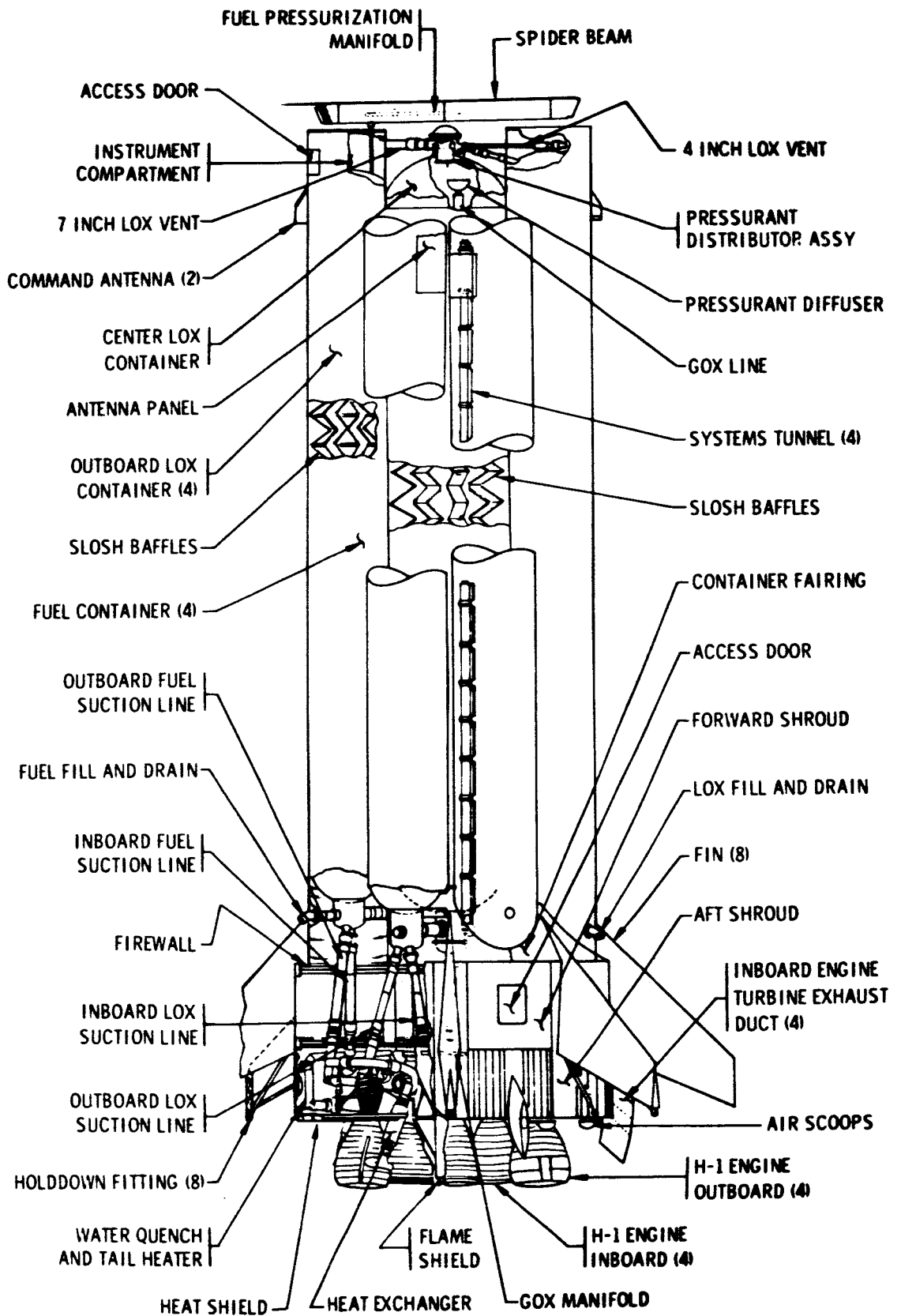

Liquid oxygen will be pumped aboard the second stage at T-2 hours, and liquid hydrogen will be loaded at T-1 hour, 55 minutes. By T-60, liquid hydrogen loading is scheduled for completion.

The service structure around the launch vehicle is to be pulled back at T-3 hours, 45 minutes. The pad is cleared an hour later and the blockhouse doors are sealed at T-30 minutes. The countdown is accomplished automatically by computers beginning at T-2 minutes, 43 seconds shortly after the launch supervisor gives a clear-to-launch.

LAUNCH COMPLEX 37

Complex 37, where the mission will be launched is a 120-acre facility on the northern edge of Cape Kennedy. The service structure stands 310 feet tall and weighs 10 million pounds.

The launch pad consists of a metal pedestal 47 feet high with a 12-sided opening in the center for escape of rocket exhaust. A flame deflector-shaped like an inverted V-is wheeled in place beneath the pedestal opening to disperse rocket exhaust and lessen pad damage. The surface of the metal flame deflector is coated with heat resistant concrete-like material which bears the brunt of the exhaust impingement.

Service systems include: RP-1 fuel, liquid oxygen and high pressure storage batteries for gaseous nitrogen, helium and hydrogen.

The last six of the ten Saturn I space vehicles were launched from the Complex. It has been modified for the Up-rated Saturn I program.

APOLLO/SATURN 203 SECOND STAGE

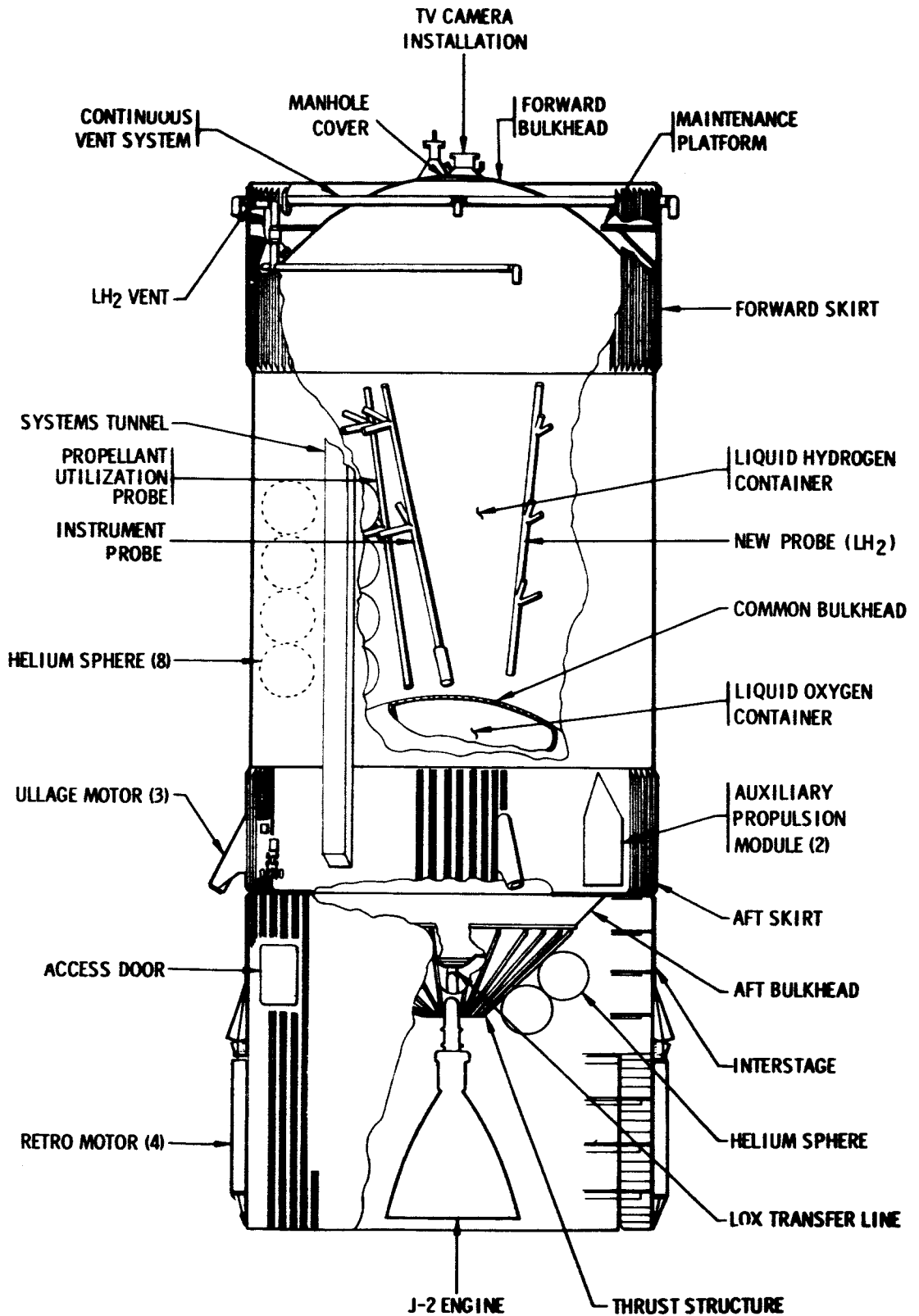

MISSION OBJECTIVES

Objectives are to evaluate performance of the second stage and instrument unit in Earth orbit to obtain information on the following:

1. S-IVB Stage Continuous Venting System -- This system maintains propellants in a settled condition throughout the orbital coast period prior to engine restart. During earth orbit, venting is required due to the high heat input to the hydrogen tank and must be accomplished with a minimum loss of propellants. The continuous vent system makes use of the hydrogen which must be vented by directing the stream of gaseous hydrogen aft to produce longitudinal thrust. This acceleration maintains the hydrogen in a settled state, which will help to minimize boiloff, in case the evaporation is greater than expected. It also minimizes the amount of additional propellant settling which may be necessary from the ullage rockets of the auxiliary propulsion system (APS) to meet engine start conditions. System characteristics to be observed include the adequacy of about six pounds minimum thrust in maintaining settled liquid hydrogen conditions and the operation of the thrust balance of the continuous venting ports.

2. J-2 Engine Chillover and Recirculation System and Ullage Requirements for Simulated Engine Restart -- In order to restart the J-2 engine, the engine propellant feed, turbomachinery and engine bell must be chilled down to assure proper quality of propellant to the engine during the starting phase. In order to force gas bubbles out of the suction lines and to assure proper temperature of the line, a recirculation system is used to keep the fuel moving in the lines for five minutes prior to restart. The J-2 engine will not be restarted, but an adequate evaluation of the systems described here, coupled with ground test data, will confirm ability to restart.

3. Cryogenic Liquid Vapor Interface and Fluid Dynamics in Near Weightless Environment -- The static and dynamic behavior of liquids in a reduced gravity field is of prime importance to S-IVB stage operation. In large diameter propellant tanks the seemingly small force resulting from aerodynamic drag, rotation of the vehicle about its center of mass, and variations in accelerations may have a significant effect on the behavior of fluids. The attitude control system will cause propellant sloshing, which will be controlled to an unknown degree by special anti-slosh baffles and a deflector installed in the hydrogen tank, but behavior of a liquid at very high frequency ratios is not completely known. Two cameras have been installed in the S-IVB forward bulkhead to observe LH_2 during the orbital period.

4. Heat Transfer to Liquid Through Tank Wall and Data on Propellant Thermodynamic Model -- Analytical data indicate that boiling will occur at the LH₂ tank sidewall during a portion of the orbital period. The acceleration induced by continuous venting is only theoretically sufficient to support a boundary layer. It is possible that boiling could cause the tank wall to become vapor bound which would drastically affect heat input. The heat transfer phenomena are not well defined, but a significant reduction in heat input could result in excessive repressurization requirements. Significant characteristics to be observed include temperature distribution in the ullage space and in the liquid boundary layer at the tank wall and outside skin temperatures.

5. Second Stage and IU Checkout in Orbit -- This will be the first opportunity to observe the extended operational life of the electrical systems during the low gravity and vacuum environment. This is not a checkout in the strict sense but it is a monitoring and updating of the systems as they function during the orbit. There will be special command functions performed, orbital updating and programming of switch selector functions.

6. S-IVB Auxiliary Propulsion System Operation (Attitude Control) -- The APS provides roll control of the upper stage during powered flight and complete attitude control of the stage (roll, pitch and yaw) during the orbital period. Proper attitude control must be maintained to determine the LH₂ behavior in the low gravity environment and enable an adequate measurement of the heat transfer characteristics during orbit.

7. S-IVB and IU Thermal Control System -- It is the first opportunity to test the orbital functioning of S-IVB and IU thermal control system, which circulates a cooling fluid internally through "cold plates" upon which electrical equipment is mounted.

8. Up-rated Saturn I Guidance System Operation -- For the first time an opportunity is presented to show the ability of the guidance system to insert a satellite into orbit (the first vehicle flight was suborbital). The guidance system, using the path-adaptive scheme, makes in-flight guidance decisions based on real-time measurements of position, velocity and time, thereby providing the most efficient use of the vehicle performance. During the orbital period the system will maintain proper attitude of the vehicle by pulsing the APS roll, pitch and yaw attitude control engines.

9. Structural Integrity of Launch Vehicle, Structural Loads and Dynamic Characteristics -- The first two boosters made for the Up-rated Saturn I program were modified Saturn I designs. AS-203's booster or first stage is the first unit designed for Saturn IB missions. About 20,000 pounds have been trimmed from the Saturn I series structure and it will be undergoing its first flight test, as well as will the new S-IVB aft skirt and the nosecone. Acoustics, temperature, pressure, strain gage and vibration measurements will be made to evaluate how well the structures function.

Secondary

1. Evaluate the launch vehicle powered flight external environment, confirming the aerodynamic analyses and wind tunnel data on which the vehicle design was based.

2. Verify the operation of the launch vehicle sequencing system which controls events during powered flight and orbital coast.

3. Although this rocket does not carry an Apollo spacecraft, the emergency detection system was retained and is being flown in "open loop" (unmanned) for evaluation purposes.

4. Evaluate separation of the second stage/IU/nosecone from the first stage.

5. Verify the launch vehicle propulsion systems' operations and evaluate performance parameters.

6. Evaluate a Manned Spacecraft Center experiment in the nosecone, testing a method of cryogenic storage under orbital conditions.

SUBCRITICAL CRYOGENIC EXPERIMENT

The system consists of an instrumented double walled spherical cryogenic storage vessel, a quantity gauging system, and other necessary system components and signal conditioning equipment to permit transmitting data.

The objectives of the experiment are to test the ability to gauge the vessel content and the capability to supply warm nitrogen vapor from the minus 320 degree fahrenheit liquid-vapor mixture. Both must be accomplished in a low gravity environment.

Data from this experiment is desired to support design of subcritical cryogenic storage systems particularly for fuel cell development for future manned spacecraft. Subcritical cryogenic storage offers weight savings over the supercritical cryogenic approaches employed on the Gemini and Apollo spacecraft.

INSTRUMENTATION AND DATA ACQUISITION

Engineers have outfitted the second stage with unique devices for this flight. They include a television system, a new tape recorder and a propellant monitoring device.

There will be a total of 1,491 measurements -- 550 on the Saturn first stage; 581 on the second stage (83 of which are peculiar to the liquid hydrogen test); and 360 on the instrument unit (eight of which are peculiar to the test).

Second Stage Instrumentation

Signals from two television cameras recording the behavior of liquid hydrogen will be received at four stations. Special recording equipment was installed by the Marshall Space Flight Center at the sites. Telemetry, tracking and update information also will be recorded at manned space flight network stations operated by the NASA Goddard Space Flight Center.

The cameras are mounted on the "manhole" cover on the forward end of the second stage's liquid hydrogen tank.

Both cameras are mounted so they "see" essentially the same area at the bottom and side of the tank. Special markings on the tank wall will enable engineers to make judgment as to the approximate level of the liquid hydrogen during the experiment.

Two 300 watt lights provide the light needed for the television cameras. The lights are enclosed and therefore are explosive proof.

Quartz windows about 3/4 of an inch thick isolate the cameras and lights from the supercold liquid hydrogen. Both cameras also have resistance heating elements around them to keep them warm in the harsh environment -- minus 423 degrees F.

One of the television instruments is manufactured by General Electrodynamics Corp. It has a one-half inch vidicon with 400 lines resolution. The other model, made by Kontel, has a one inch vidicon with 700 lines resolution.

Only one of the cameras will operate at a time. Engineers will switch the cameras from time to time through the command link in the instrument unit. Signals will be transmitted through an S-band television link to the Kennedy Space Center, Fla.; Bermuda; Carnarvon, Australia and Corpus Christi, Texas stations.

Signals received at Cape Kennedy and Texas will be retransmitted to the Mission Control Center in Houston and the MSFC Operations Support Center for use in direction of the mission. The Australia and Bermuda stations will record signals for later study.

A novel dual capability tape recorder, mounted on the S-IVB's forward skirt, will record both analog and digital data. It will operate in the analog mode during staging and will play back the information after second stage cutoff.

The instrument also has the unique capability of recording digital data during the periods the satellite is between ground stations. It will record at a slow speed for 56 minutes and play back the information in seven minutes while in range of a station. It is expected to provide continuous monitoring of the liquid hydrogen test for four orbits.

Stations picking up the recorded information will be Canary Island, Tananarive, Canton Island, Hawaii, Ascension Island, and Antigua Island.

A new probe has been installed in the second stage hydrogen tank to accommodate many of the special temperature, pressure and other measurements. There are two probes in the standard second stage -- instrument probe and propellant utilization probe.

Twenty-three of the 57 temperature measurements are unique. Fifteen of these sensors are "zero g" type temperature transducers. Other sensors include a dual element temperature sensor located in the liquid hydrogen feed duct and instruments to measure on both sides of the common bulkhead.

Other special devices include three instruments for vent exit differential pressure measurements and seven liquid/vapor sensors to determine the state of the liquid hydrogen at varying levels.

The instrument unit has five measurements peculiar to the experiment to record forces acting on the stage caused by venting, propellant movement and similar forces. These measurements are made from three accelerometers located in the instrument unit. One accelerometer measures the longitudinal forces, the other two measure pitch and yaw.

This flight also marks the first active use of a new range safety system which gives the space vehicle a greater degree of radar immunity than the system previously used.

Any vehicle launched from the Eastern Test Range must have a command destruct system in the event it goes off course. The new system, which has been flown as a passenger on three previous Saturn flights, protects the destruct system from stray radio frequency interference.

Engineers discovered early in the Saturn I program that the radio frequency "missing" and stray signals from a variety of sources were a hazard and fear that these stray signals could trigger the destruct system.

AS-203 NETWORK SUPPORT

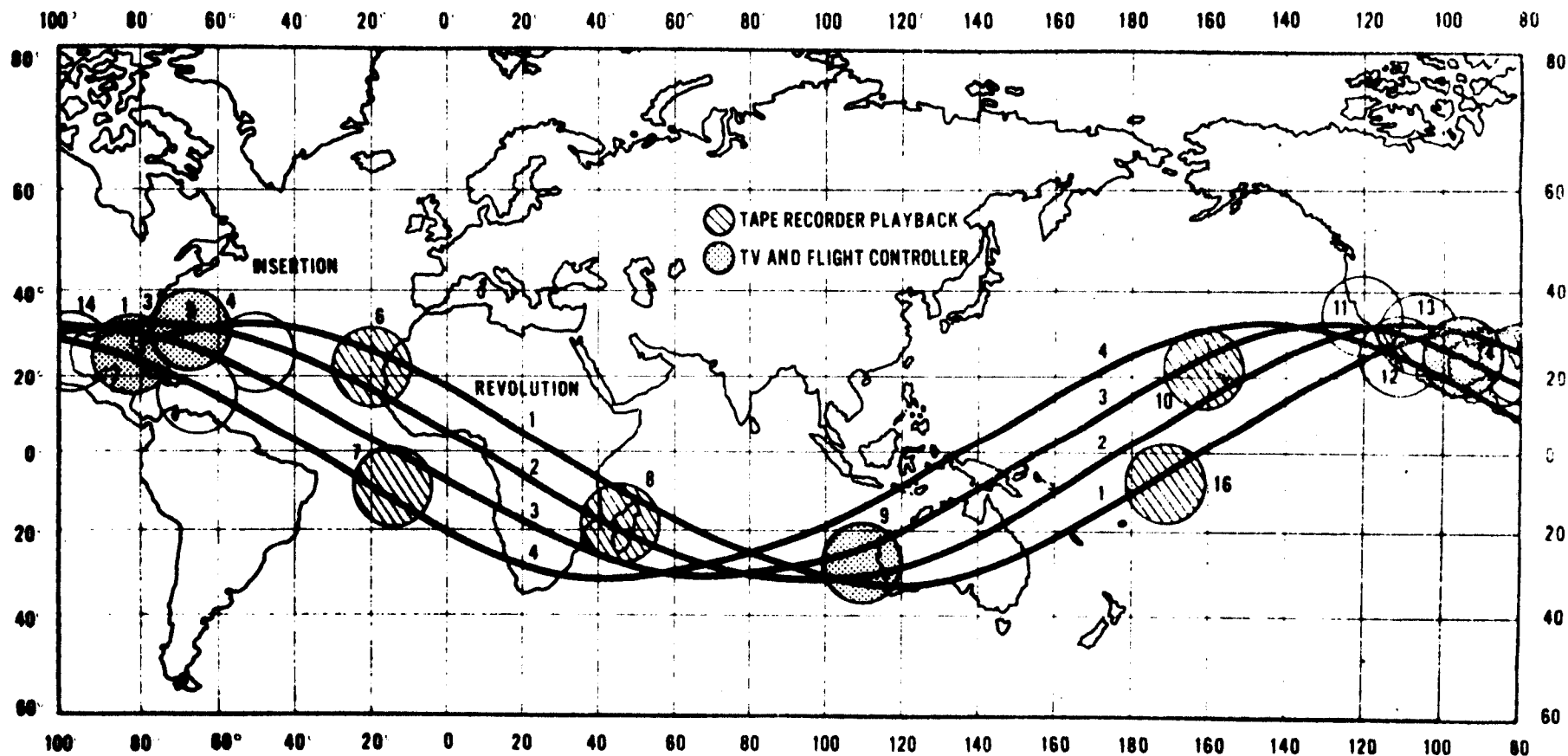

STATION NETWORK

- 1. CAPE AREA ●
- 2. GRAND BAHAMA ●
- 3. BERMUDA ●
- 4. SHIP ●
- 5. ANTIGUA ●

- 6. CANARY ISLAND ●
- 7. ASCENSION ●
- 8. TANANARIVE ●
- 9. CARNARVON ●
- 10. HAWAII ●

- 11. POINT ARGUELLO ●
- 12. GUAYMAS ●
- 13. WHITE SANDS ●
- 14. CORPUS CHRISTI ○
- 15. CANTON ISLAND ○

The new system is tailored to operate in a multi-frequency environment. Coding techniques provide a higher degree of protection from stray signals, and the probability of accidental triggering of the system is remote.

Special First Stage Instruments

Motion picture cameras -- two wide angle 16mm Milliken movie cameras will photograph separation of the first and second stages. They have 160 degree lenses and an operating range of 130 degrees. Film speed is 128 frames per second.

The cameras (one with black-and-white film and the other color film) are mounted on the top of the first stage pointing toward the second stage engine.

Camera operation will begin some three seconds before stage separation. They will be ejected 25 seconds after separation, about 300 miles down range.

The cameras are encased in recoverable capsules. Parachutes will open soon after ejection and balloons will keep them afloat. Radio beacons and dye markers will assist an Air Force recovery team to locate the capsules.

The cameras are expected to operate the first few seconds in total darkness and a few seconds later may be pointing directly into the sun. Special black-and-white film is being used to compensate for this expected difference in light. The film has a three-layer emulsion and is expected to provide a wide exposure latitude in the varying light conditions. It will be processed three different times.

Chrysler Corp., assembled and tested the camera packages for the Marshall Center.

Infrared Spectrometer -- An infrared spectrometer is used to study emission spectra of rocket engine plumes. Due to the extreme environmental conditions, a specially designed unit was built.

The flight unit, although lighter than the Block E-8 unit from which it was developed, is stronger because of the optics being clamped in rather than glued, heavier bearings on the moving parts and an alloy frame.

The device operates in the infrared region of approximately 1.5 to 4.5 microns wavelength.

Instrumentation by Unit

First Stage	four telemeter links 550 measurements one ODOP tracking transponder two film cameras two dual range safety protective devices
Second Stage	five telemeter links dual range safety system 581 measurements 83 are peculiar to LH ₂ experiment television cameras tape recorder
Instrument Unit	four telemeter links 360 measurements eight are environmental from nosecone five are peculiar to LH ₂ experiment 13 are for MSC's cryogenic experiment 26 emergency detection system measurements normally sent to the spacecraft two transponders for tracking AZUSA C-Band radar
Nosecone measurements (all telemetered from IU)	two acoustic -- external one acoustic internal two static pressure external three acceleration -- bending mode redundant EDS Q ball

Ground Network

Mission control will be at the Manned Spacecraft Center in Houston. The flight will be controlled directly from the Mission Operations Control Room until the range of the Air Force Eastern Test Range tracking and command facilities are exceeded. Control commands will then be transmitted by voice communications to stations in the Manned Space Flight Network.

Engineers from the Marshall Space Flight Center are cooperating with the Manned Spacecraft Center and the Goddard Space Flight Center in manning key positions in the network for this flight.

Positions added especially for this experiment include a flight director's experiment representative, an experiment systems engineer, and experiment system engineer's representatives at five remote sites.

Stations in the network include Cape Kennedy, Grand Bahama, Bermuda, Insertion ship, Antigua, Canary Island, Ascension, Tananarive, Carnarvon, Hawaii, Point Arguello, Guaymas, White Sands, Corpus Christi, and Canton Island.

LIQUID HYDROGEN EXPERIMENT

A main point of concern in the orbital use of hydrogen is assurance that the fuel can be settled to the lower bulkhead or bottom of the fuel tank and kept there, covering the engine pump inlet and ready to supply the engine pump with fluid -- not gas -- when it is time to restart the main engine.

A second aspect of this is the necessity of keeping the gas in the top portion of the tank, so that gas alone -- not liquid -- will be vented overboard. In space there is no natural force to seat the propellant and keep it in place. Rather, there are forces that tend to disturb it and keep it scattered in a confused, inhomogenous mixture of liquid and gas over the entire tank area.

For instance, the separation jolts and thermal gradients may have a significant effect on the behavior of the fluid. Activation of the attitude control system consisting of two sets of small rocket engines which are fired to adjust attitude, will certainly induce propellant sloshing which must be dampened out.

To maintain the hydrogen in a settled condition -- as if the vehicle were standing upright on earth -- designers must create an artificial gravity within the orbiting vehicle. The simplest way to do this is to accelerate the vehicle slightly, continuously, in its orbit. This acceleration must be sufficient to keep the hydrogen settled once the stage's small ullage rockets have settled it initially but must not use up too much fuel or accelerate the vehicle enough to change its orbit appreciably. The most promising way of providing this small continuing thrust is by venting the hydrogen tank itself -- expelling beneficially the gases created within the tank by evaporation due to the heat input.

Gases expelled through two small nozzles pointing rearward will give the stage a minimum of about six pounds forward push which will help maintain the proper condition in the tank. This constant forward thrust should keep the propellants essentially settled. On an actual Saturn V mission, two 70-pound thrusters will fire just prior to restart of the main engine to "finish the job" and assure a completely acceptable state within the tank.

There will not be a reignition of the second stage main (J-2) engine in this mission. The uprated Saturn I's weight-lifting capability is not great enough to carry propellants sufficient to perform these studies satisfactorily and also have enough oxidizer (LOX) and pressurants left over to do an actual second burn. To have attempted both goals would have meant compromising one of them to an unacceptable degree. Therefore, since the engine has been restarted many times in ground tests and there is no serious question about its operation, a restart in orbit was ruled out in favor of more extensive propellant studies. Thus virtually all steps in the restart cycle will be taken except ignition itself.

Aside from propellant venting and fluid dynamics, there are other significant unknowns. The matter of heat transfer through the tank wall is important. One side of the tank will be facing the sun during a portion of the orbit while the other faces the cold void of space. Scientists assume but do not know that this high heat input will cause a considerable buildup in evaporation of the hydrogen. If this is not the case, that is, if propellant boiling at the tank skin causes the tank wall to become vapor bound and thus reduces the amount of evaporation, this could necessitate modifications to provide additional pressurants for restart.

In the updated Saturn I program, the S-IVB stage is not required to reignite in earth orbit. Therefore the stage for this flight was modified to simulate a Saturn V version.

The two 70-pound thrusters used on Saturn V version as ullage rockets to complete the settling of the propellants prior to the reignition of the J-2 are not present on the 203 vehicle. To substitute, leftover gases in the stage's liquid oxygen tank will be vented aft through two nozzles. This will furnish some 30 pounds of ullage thrust, sufficient for this test. (This is in addition to the continuing thrust, of about six pounds minimum, which will come from venting the hydrogen tank).

Following J-2 engine cutoff, a small LOX residual plus some 600 pounds of gases (helium used for pressurization and gaseous oxygen) will remain in the tank and will be used repeatedly for ullage thrusting as the various phases of the mission are carried out.

Besides the LOX venting and continuous hydrogen venting systems, other additions to this stage to make it closely simulate the Saturn V S-IVB include anti-slosh baffle and deflector within the hydrogen tank to help control the liquid, chilldown and certain other restart features of the engine.

The hydrogen tank of the upper stage will be heavily instrumented to report to ground stations how the light, powerful fuel reacts to the various methods which have been devised to harness it in space. Among the instrumentation will be two television cameras which will send pictures to four ground stations. Engineers observing TV monitors at the stations will be able to see to what degree the fuel management techniques are successful. In some situations they will be able to vary the sequence and timing of events aloft to assure success of the orbital exercise.