

#4

FACILITY FORM 602

N69-73292

(ACCESSION NUMBER) (THRU)

28 (PAGES) *Scione* (CODE)

(NASA CR OR TMX OR AD NUMBER) (CATEGORY)

# PROJECT PROSPECTOR

---

## UNMANNED EXPLORATION AND APOLLO SUPPORT PROGRAM



**GENERAL  ELECTRIC**

**MISSILE AND SPACE VEHICLE DEPARTMENT**

*A Department Of The Defense Electronics Division*

**PROJECT PROSPECTOR**

---

**UNMANNED EXPLORATION  
AND  
APOLLO SUPPORT PROGRAM**

---

**GENERAL  ELECTRIC**

**MISSILE AND SPACE VEHICLE DEPARTMENT**

*A Department Of The Defense Electronics Division*

## Table of Contents

	Page
Introduction	1
System Concepts	2
Selection of Lunar Landing Site	4
Selection of Earth Recovery Site	5
Sterilization and Lunar Life Protection	6
Sterilization of the Launch Vehicle	6
Sterilization of the Re-Entry Capsule	7
Space Truck	9
Rover/Traverser	13
Return Vehicle System	17
Configurations	20
Mission Changes Due to C-1, C-2, and Titan III Difference	23
Team Arrangements	25

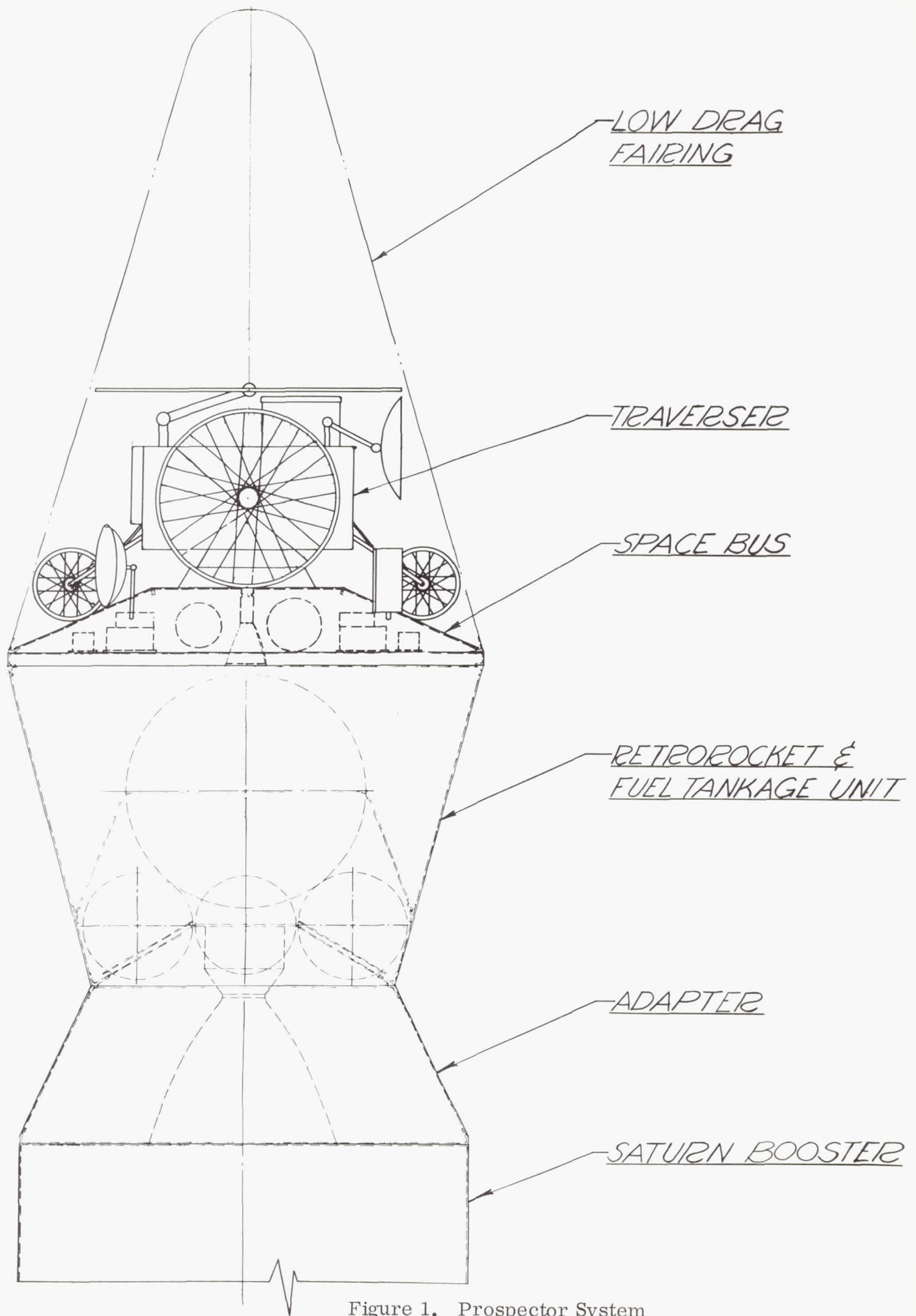

Figure 1. Prospector System

# PROJECT PROSPECTOR

## Introduction

Prior to the establishment of a manned lunar observatory or base, it is essential that a compendium of information be available on the environment, composition, structure, and topography of the moon. In an effort to satisfy this need for improved and detailed information, NASA has undertaken a lunar program which ranges from the utilization of circumlunar flight vehicles, equipped with automatic photographic and radiation measuring equipment which responds to commands from the earth, to actual determination of surface composition and features obtained from unmanned instrumented spacecraft which impact the moon.

The purpose of this report is to show an understanding of the problems of surviving and operating in the environment of the moon. The emphasis has been to describe concepts or methods of solution rather than the final hardware.

The concepts do not entail sudden introduction of a host of new devices and new techniques. All will be extensions of Ranger and Surveyor experience. However, the Rover/Traverser mission will require lunar locomotion mechanisms which may be basically new. The emphasis will be on a design whose execution can be scheduled confidentially and yet be prepared for later achievements.

A substantial portion of the design work which will be required when a booster selection is made has been accomplished during the generation of the concepts. The detailed designs that will be applicable to a specific booster can be rapidly pursued once the selection is made by the application of numbers (payload weight capability of the booster). Examples of this are illustrated by the numbers associated with the Saturn C-1, C-2 or the Titan III.

## System Concepts

The Prospector system is the most sophisticated and versatile unmanned spacecraft planned to date for a lunar mission. It will be a direct mode flight and will be capable of soft-landing a payload of thousands of pounds on the moon. The Prospector system will actually consist of three vehicles, a Space Truck, a Rover/Traverser, and a return vehicle (Moon Earth Return Vehicle). The Space Truck can be described as a versatile rocket-propelled platform or freight pallet that will be capable of carrying any of a variety of payloads to the moon that will be within its payload weight limitation. In the early stages of a lunar program preceding manned landings, the primary item of the Prospector payload may be a Rover/Traverser or mobile laboratory, which can be used in remote controlled exploration and experiments in areas of particular interest within a radius of 250 miles of the landing site. The Rover/Traverser vehicle will be sufficiently versatile to carry several alternative payloads depending upon the types of experiments to be conducted.

The most important objective of the Prospector system is the support of subsequent manned lunar flight programs. This support may be in the form of extensive surveys of landing sites for manned spacecraft, as well as the transportation of vital equipment and supplies to the moon for the manned expedition.

Since the first objective is the retrieval and transporting of lunar samples to earth, a remote earth-controlled return vehicle is also one of the payloads of the Space Truck. However after the landing of man on the moon, the Rover/Traverser could be used as a method of transportation and locomotion.

A shroud,<sup>1</sup> which is designed to cover and protect the Prospector payload will be jettisoned prior to separation of the Space Truck from the booster.

---

<sup>1</sup>The shroud has a nose radius of 2.5 feet, a base of 18 feet diameter and length of 25 feet.

Mid-course maneuvers, based on NASA/JPL DSIF radio-tracking data, will be made to correct orbit injection and separation errors. Multiple corrections (four) are used to minimize the errors of tracking and the errors of correction. A lunar aiming point accuracy of eleven miles ( $3\sigma$ ) is possible with a mid-course correction weight of 750 pounds.<sup>2</sup>

It is anticipated that the final stage of Booster will be required to coast in orbit until it attains the proper position for injection into the escape trajectory to the moon.<sup>3</sup>

As the Space Truck approaches the moon, the requisite landing maneuvers will begin when it is a predetermined distance away. A basic requirement is that the vehicle be oriented so that the decelerating rocket thrust be appropriately aligned relative to the lunar approach velocity.<sup>4</sup> The moon landing sequence involves 1) stabilizing the vertical attitude; 2) operating the television equipment; 3) firing the main retro thrust; 4) firing the fine retro thrust to further reduce velocity; 5) sensing terrain information; and 6) making required maneuvers for landing at the site location.<sup>5</sup>

---

<sup>2</sup>Error sensitivities of  $\pm 1$  mile or  $\pm 5$  feet per second could result in a 350 mile error in range on the moon. According to the JPL orbit determination program (Professor Lawden), the optimum time to apply the first mid-course correction is 20 hours after injection. The last mid-course correction is at 10,000 miles range from the moon.

<sup>3</sup>For about 20 minutes or 85 degrees of arc from Cape Canaveral.

<sup>4</sup>This attitude control maneuver is important because it permits a lateral change of the landing position so that the 11 mile ( $3\sigma$ ) is reduced to 1.0 mile. This gives the system a terrain avoidance capability for only 160 pounds propellant penalty.

<sup>5</sup>Typical Profile:

1. fifteen minutes (400-100 mile altitude) before touchdown a marker radar and television are turned on for observation of the terrain; for terrain avoidance maneuvers.
2. five minutes before touchdown (about 50 mile altitude) the retro engines are fired ( $V_{BO}$  is about 0-500 feet per second for a two minute duration).
3. three minutes before touchdown (about four to five miles altitude) the vernier retro engines are control fired so that the touchdown velocity is ten feet per second or less (lateral component of 1.75 feet per second or less).

After the Space Truck lands, the Rover/Traverser will be released and will proceed to explore the lunar surface for the equivalent of ten earth days. Measurements of the composition and physical properties of the moon will be made, and the results analyzed and telemetered to earth. Measurements will include temperature, radiation levels, magnetic fields, atmospheric density, surface and subsurface conditions, geodesy and surface mapping, as well as obtaining lunar samples to be placed in the earth return vehicle (MERV).

Upon completion of the lunar exploration and obtaining the lunar samples, the return vehicle will be launched for the trip to earth.

## **Selection of Lunar Landing Site**

Several investigations have discussed the problem of where to land on the moon. It would appear desirable to select a site which is visible from the earth, upon which both landing and take-off for the return to earth can be made conveniently. Obviously, it would be desirable to avoid rough terrain, since a mobile vehicle is to be employed in the surface exploration experiments. Likewise, it would be advisable to avoid high temperature zones, and to concentrate on the cooler areas. The landing site should be sufficiently close to a variety of lunar surface features that would be accessible with the aid of the Rover/Traverser.

An ideal landing site would likely be in the Straight-Wall area where the temperature varies from 32 degrees to 85 degrees C. A variety of craters, valleys, and mountains of lunarite material would be available for exploration in this area.

It is realized that the final selection of a lunar landing site should take into account trajectory considerations, vehicle dynamics, mission requirements, as well as the lunar environment. It is entirely possible information obtained from



projects such as Ranger and Surveyor, and from television photographs as the Space Truck approaches the moon, will be influential in determining the final location of the landing site.

## **Selection of Earth Recovery Site**

Initial considerations for the design of the re-entry capsule were based on the assumption that it should be capable of surviving either water or land impact. However, a preliminary evaluation revealed that a design for water impact would be much lighter than one designed for both land or water impact; furthermore, more reliable search and recovery techniques could be employed with the water impact design.

Certain constraints are necessarily imposed on the recovery area, such as:

- 1) It should not be contiguous to heavily-populated land areas or unfriendly areas.
- 2) Climatic conditions such as visibility and temperature should be conducive to search and recovery.
- 3) Utilization of search forces should not be economically prohibitive. For example, adequate tracking facilities should be accessible at reasonable cost.

From the above considerations, it would appear that the Pacific Ocean area fits the requirements as a recovery site. Further study will be required before the exact size and location of the optimum recovery area can be specified. (In the following discussions a first cut solution describing a possible recovery area 1000 miles square with a center of 140 degrees W longitude and 15 degrees N latitude is described.)

# Sterilization and Lunar Life Protection

## STERILIZATION OF THE LAUNCH VEHICLE

It has been established at the national meetings on Problems and Techniques Associated with the Decontamination and Sterilization of Spacecraft that the launch vehicle should be thoroughly sterilized in order to prevent lunar contamination.<sup>1</sup> This protection includes both biological and chemical techniques. However, neither the criteria for the vehicle sterilization nor the mission environmental factors of vacuum, temperature and radiation on sterilization are as yet fully evaluated. Establishing the criteria and attaining the required sterilization will require extensive theoretical investigation and experimental evaluation.

Among the most difficult forms of life to kill are bacterial endospores; although high heat (150 degrees C) and chemical disinfectants are effective, their limits of tolerance are unknown. As a first cut solution it might be wise to use methods ridding all trace of these forms. (Biokinetic temperatures range from near absolute zero to 150 degrees C.) There should be no real problems with decontaminating the exterior of the vehicle and all items which can be reached by gaseous and liquid disinfectants. The disinfectant materials of choice include ethylene oxide and peracetic acid.<sup>2,3</sup> Sterilization of the shell of the vehicle can also be accomplished by gamma radiation from a cobalt 60 source.<sup>4</sup> In order to insure that all contents of the vehicle are sterile in case of damage to the vehicle upon landing, it will be essential that design considerations are such that only sterilized materials are used in the construction.

---

<sup>1</sup>Proceeding of Meeting on Problems and Techniques Associated with Decontamination and Sterilization of Spacecraft, Ed. by Jack Posner, June 1960.

<sup>2</sup>Clifton, C. E., "Introduction to the Bacteria" Second Ed. McGraw Hill Book Company, New York 1958. 558 pp.

<sup>3</sup>Lamanna, C., Mallette, M.F., "Basic Bacteriology Its Biological and Chemical Background," Williams and Wilkins Co., Baltimore, 1959. 853 pp.

<sup>4</sup>Ibid., See Page 7, Footnote 1

Selection of materials should include the ability to be sterilized by either heat, chemicals, or radiation. The use of ultra-violet radiation throughout the construction of the component parts would further preserve sterility. It will be necessary that the component parts not be contaminated preceeding launching and that last minute use of gamma radiation coupled with the low temperature on the launch pad be used to insure a minimum microbial count in agreement with a plan of minimum tolerance suggested by JPL.<sup>5</sup> No single method will be universally accepted due to the deleterious effects which might occur to material properties or component functioning.

#### STERILIZATION OF THE RE-ENTRY CAPSULE

Assuming there is lunar life,<sup>6</sup> precautions must be taken so that no living or potentially living materials are returned except those within the re-entry capsule. For this reason, it will be necessary to sterilize the re-entry capsule and the external portions of the sample container before recovery. In conformity with the Le Chatelier principle it appears that disinfectants will be more effective in the decreased pressures encountered in space.<sup>7</sup> Studies at the Lobund Institute of Notre Dame, strongly suggest the applicability of peracetic acid showers or fogs to decontaminate. An atomizer could provide a sterilizing fog inside the vehicle on the return trip.<sup>8</sup> A constant UV (2500 A) source impinging on the shell of the sample container can be used to further sterilize. Careful application of polyethylene enveloping structures will insure the sterility of the sample capsule in case of leakage of the re-entry vehicle into the atmosphere.

<sup>5</sup>Hibbs, A. R., "Space Science and Instrumentation" JPL Industry Conference Proceedings. Reports No. 30-1 P. 41-64. 1960.

<sup>6</sup>"Microbiologic Studies on Ecologic Considerations of the Martian Environment" Rev. 2-60, School of Aviation Medicine, Brooks Air Force Base, Oct. 1959.

<sup>7</sup>Ibid., See Page 8, Footnote 3.

<sup>8</sup>Proceedings of the Second Symposium on Gnotobiotic Technology. University of Notre Dame, Indiana, ASTIA #241 197, May 8, 9, 1959.

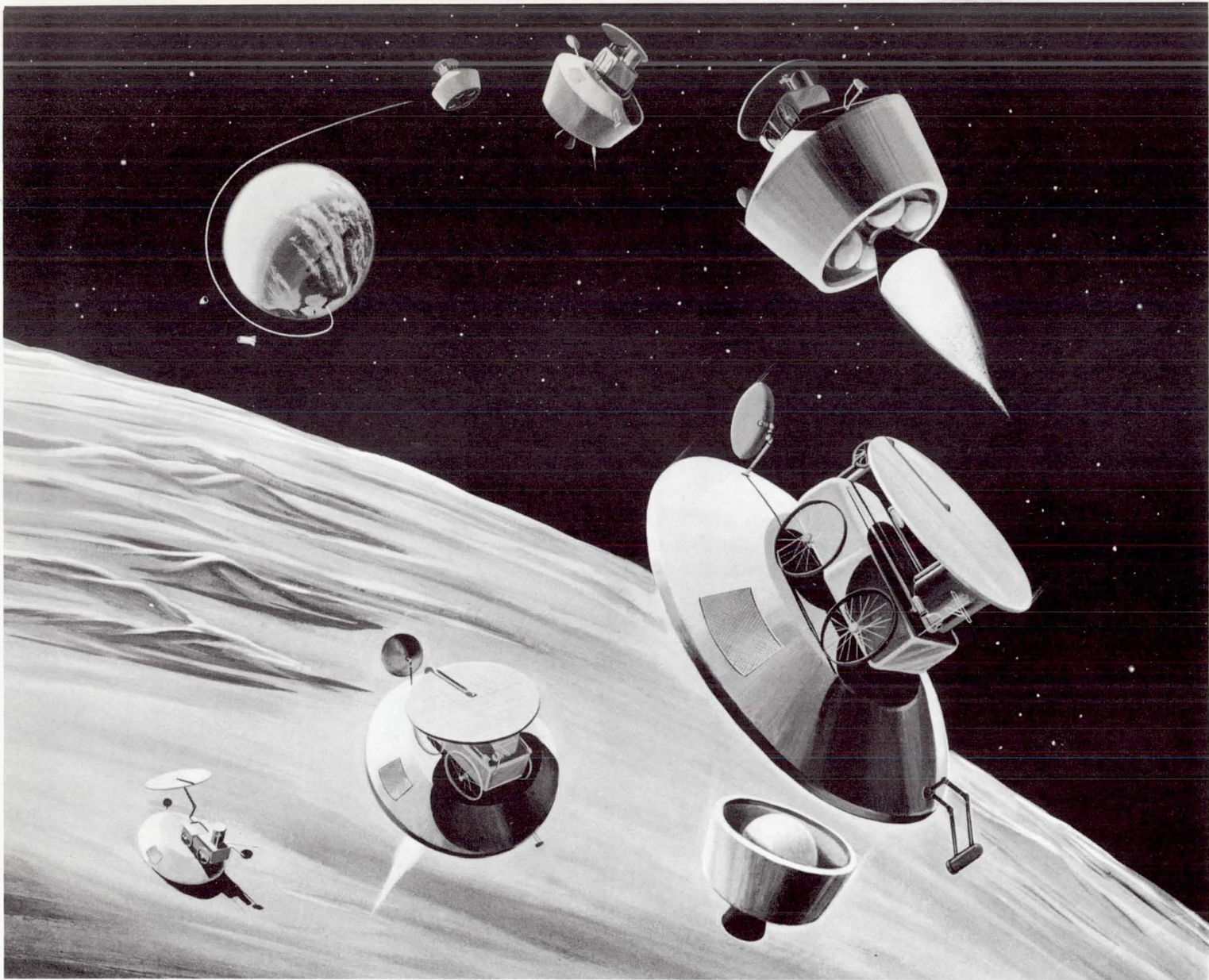

Figure 2. Lunar Mission - Space Truck Mission Profile

## Space Truck

The booster system consists of at least three configurations, C-1, C-2 and Titan III; all of which have different lunar soft-landing capabilities. The missions and the configurations described are for the three vehicles based on the Saturn C-2 capability (at the end of this discussion, the missions and capabilities will be described for the C-1 and Titan III. The Space Truck is envisioned as a circular platform on which sits the payload to be transported to the moon. The design of the structure is such that the perimeter of the platform is sloped so that this may be used as an unloading ramp without any excess weight penalty. Beneath the super structure are located the two retro propulsion systems and its tankage. The reasons for using two engines, a main retro and a vernier are: 1) reliable soft-landing; and 2) maintaining the height of the platform from the lunar surface at a minimum. An engine of the size necessary for providing the retro thrust to soft-land on the moon is of the order of ten feet or more in height. By jettisoning this sometime during the landing stage (main retro engine burnout is at about four to five miles altitude) and permitting a smaller retro engine to complete the landing permits keeping the platform height at a minimum of two to three feet. A cryogenic engine ( $\text{LO}_2/\text{LH}_2$ ) will be the most efficient engine to use as a main retro because of the higher specific impulse, but during the final operation of performing the soft-landing of ten feet per second or less, either an on-off operation or a fine throttling operation is required. An on-off operation can be performed reliably by a hypergolic type engine. Fine throttling can be performed more efficiently and reliably by a smaller engine. Either of the above requirements dictates another engine, hence a two engine system.

To further assure a soft-landing of ten feet per second or less, a structure consisting of a circle of pneumatic landing bags will be built around the bottom circumference of the Space Truck.

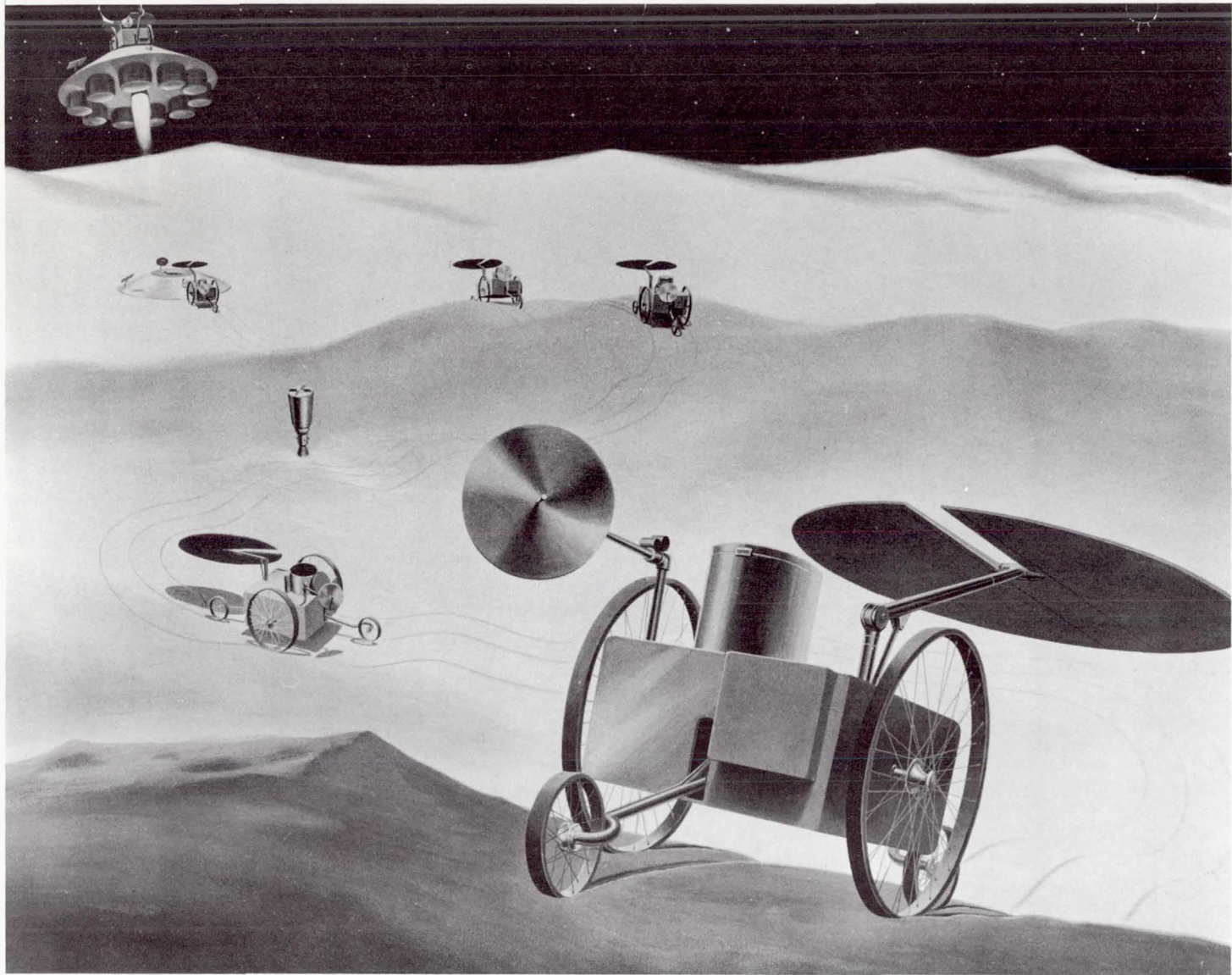

Figure 3. Lunar Mission - Single Axle Traverser

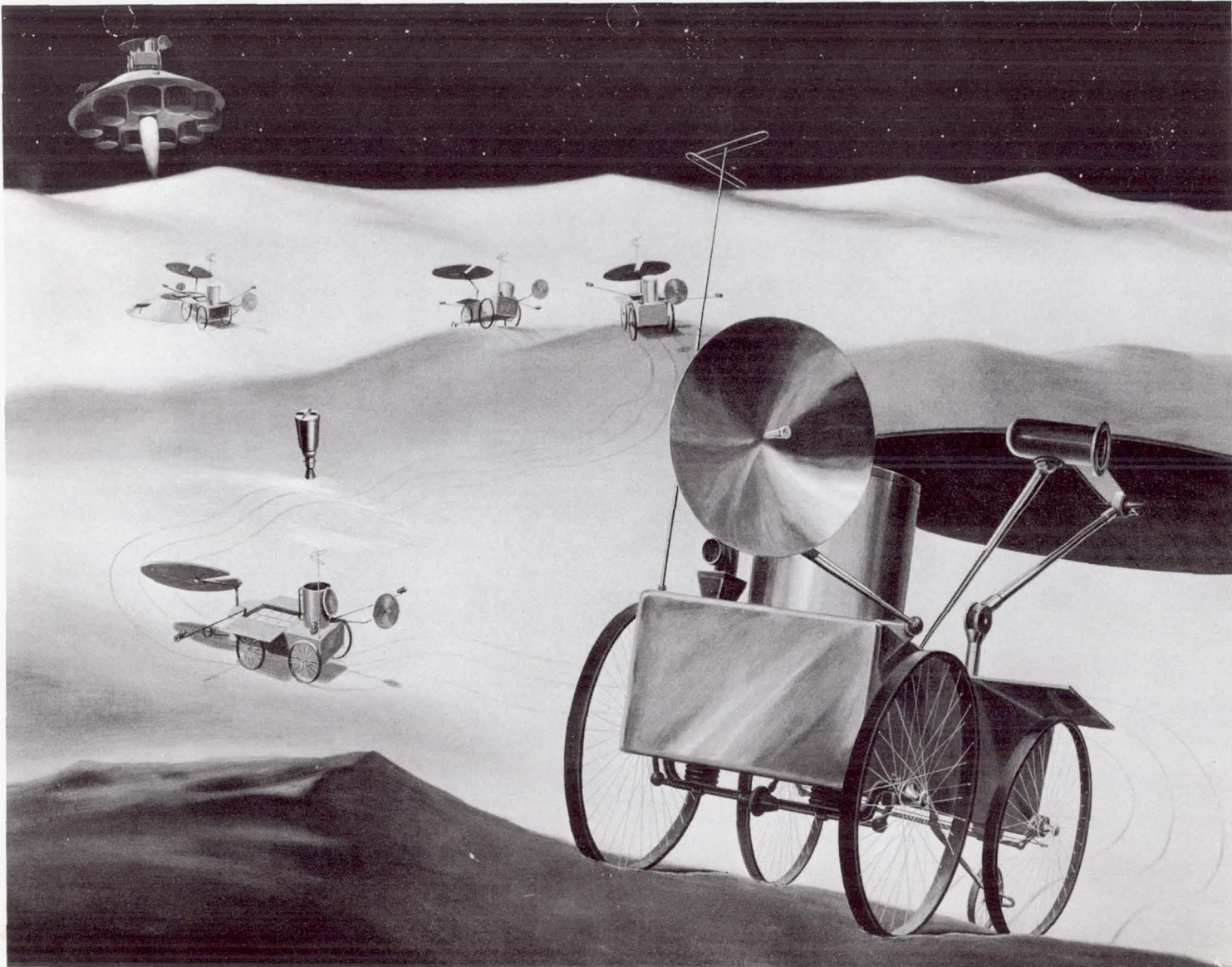

Figure 4. Lunar Mission - Multi-Axle (Four-Wheel) Traverser

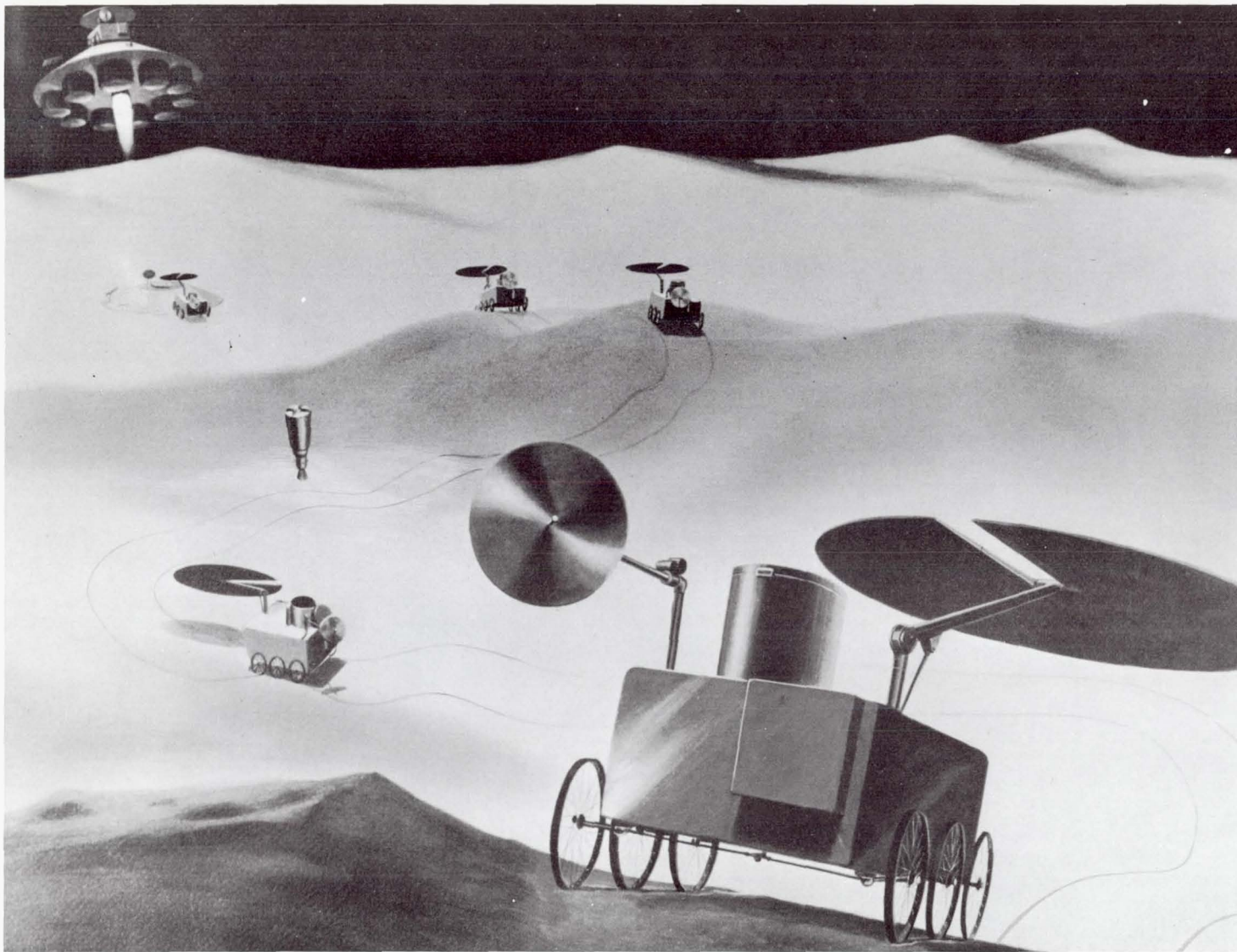

Figure 5. Lunar Mission - Multi-Axle (Six-Wheel) Traverser



The control of the retro engines is performed by a combination of radar altimeters, inertial platforms, and television observations. Through a television link, an operator on earth can control the rockets; however, should the television link fail, the radar altimeters can operate automatically in the absence of a signal from earth to perform an automatic landing.

## Rover/Traverser

The Rover/Traverser is essentially a mobile platform from which the lunar experiments can be operated. Because of the environment in which it operates, its design requirements are identical in many ways to a space probe or vehicle. The hard vacuum, the extreme operating temperature limits, exposure to high and low energy radiation, bombardment by meteor and micro-meteorite are very similar.

The extensive experience and technique acquired at MSVD in the development of the Advent and Nimbus programs have been utilized to meet these requirements. The difference is that the vehicle will operate on a physical surface rather than in space and be subject to a gravity force. Because of the latter requirements, the Rover/Traverser must use methods of locomotion that are familiar on earth. An investigation to determine the most efficient and reliable mode of locomotion covers the conventional wheels and tractor treads to the unconventional shuffling walkers. Because of the nature of the expected terrain on the moon<sup>1</sup> coupled with the desired high operation reliability and low power availability, the conventional wheel was chosen.

Using the same ground rules that described the lunar terrain as dust, sand, rock strewn lava beds laced with crevices, and a system requirement of minimum available power and high maneuverability, two concepts were studied. The principle of locomotion was common.

---

<sup>1</sup>Buwalda, P., JPL Technical Release No. 34-159.

In concept one, the single axle configuration, the experiment platform is supported by a single axle and located between the wheels.<sup>2</sup> This configuration has the advantage of high maneuverability and simplicity.

In concept two, the multi-axle configuration, the experiment platform is supported by two or more axles.<sup>3</sup> The configuration has the advantages of high obstacle performance and stability. In either case the particular design of the Rover/Traverser permits the carrying of the return vehicle by the Rover/Traverser. This has the advantage of simplicity of loading the lunar samples and the data storage unit for return to earth. From the reliability point of view, it has the advantage that should the Rover/Traverser encounter any difficulty, which could prevent it from rendezvousing with the return vehicle to deposit its lunar samples and data storage for return to earth, it is already present and ready to take off.

The prime power supply of the Rover/Traverser is based on solar radiation<sup>4</sup> because of the long life requirements (a minimum of 28 earth days). It is backed up by Ni-Cad batteries and a rechargeable fuel cell for lunar night survival (a radio-isotope-thermo-electric system is also under consideration).

Engineering and scientific data must be communicated to earth in order to be of value. Two-way communication also is necessary so that the Rover/Traverser can receive commands. Rover/Traverser Command is by a programmer on the Rover/Traverser that supplies all of the necessary commands for routine operation because of a real time delay in communications. However, manual override by television and radio link is provided for unanticipated situations which require

---

<sup>2</sup>In this concept the platform is 7' x 7' and mounted on five foot diameter wheels.

<sup>3</sup>In this concept the platform is 7' x 7' mounted on four foot diameter wheels.

<sup>4</sup>The system concept consists of 152 pounds of solar paddle (136 square feet of solar cells), 70 pounds of battery and 35 pounds of rechargeable fuel cell.

variation of the programmed commands. Since communications distance are of the order of 250,000 miles, efficient transmitters and high gain directional antennas with stowability will be used.<sup>5</sup> To augment this capability, the NASA/JPL DSIF will be utilized; that is, the system will be compatible with the DSIF.

In order to perform its function, the Rover/Traverser vehicle is designed to withstand the extreme temperature ranges of 130 degree C (266 degrees F) during the day to -150 degrees C (-238 degrees F) during the night. The basic thermal philosophy which has been indicated by this study is to control the emissivity of the vehicle. This may be accomplished by a combination of a passive emissivity and absorbtivity surfaces and thermal doors which open and close automatically to regulate the outward heat flow. An internal temperature range of 20 degrees F to 100 degrees F can be maintained using this technique.

The location of the Rover/Traverser on the moon is very important for three reasons:

- 1) One of the operations of the Prospector project is to secure samples of the moon and return them to earth. A return vehicle (MERV) must be remotely launched from the lunar surface and returned to earth. To insure that it will return and land at a preselected recovery site, it must be supplied with accurate guidance information. This accurate guidance can be computed if the exact location of the vehicle on the moon is known.

---

<sup>5</sup>The communication system concept consists of an S-Band Transmitter operating at a frequency of 2200 MC with a power output of five-watts which will be used with a directional antenna of 26 db gain (four feet diameter). This system is quite capable of maintaining a television link with earth but only at a reduced capacity, i.e., sending only the minimum data compatible with the information bandwidth. Only a fraction of the television scenic observation, experimental observation and steering observation are sent to earth directly, the balance is stored on a thermoplastic tape recorder for physical return to earth for analysis.

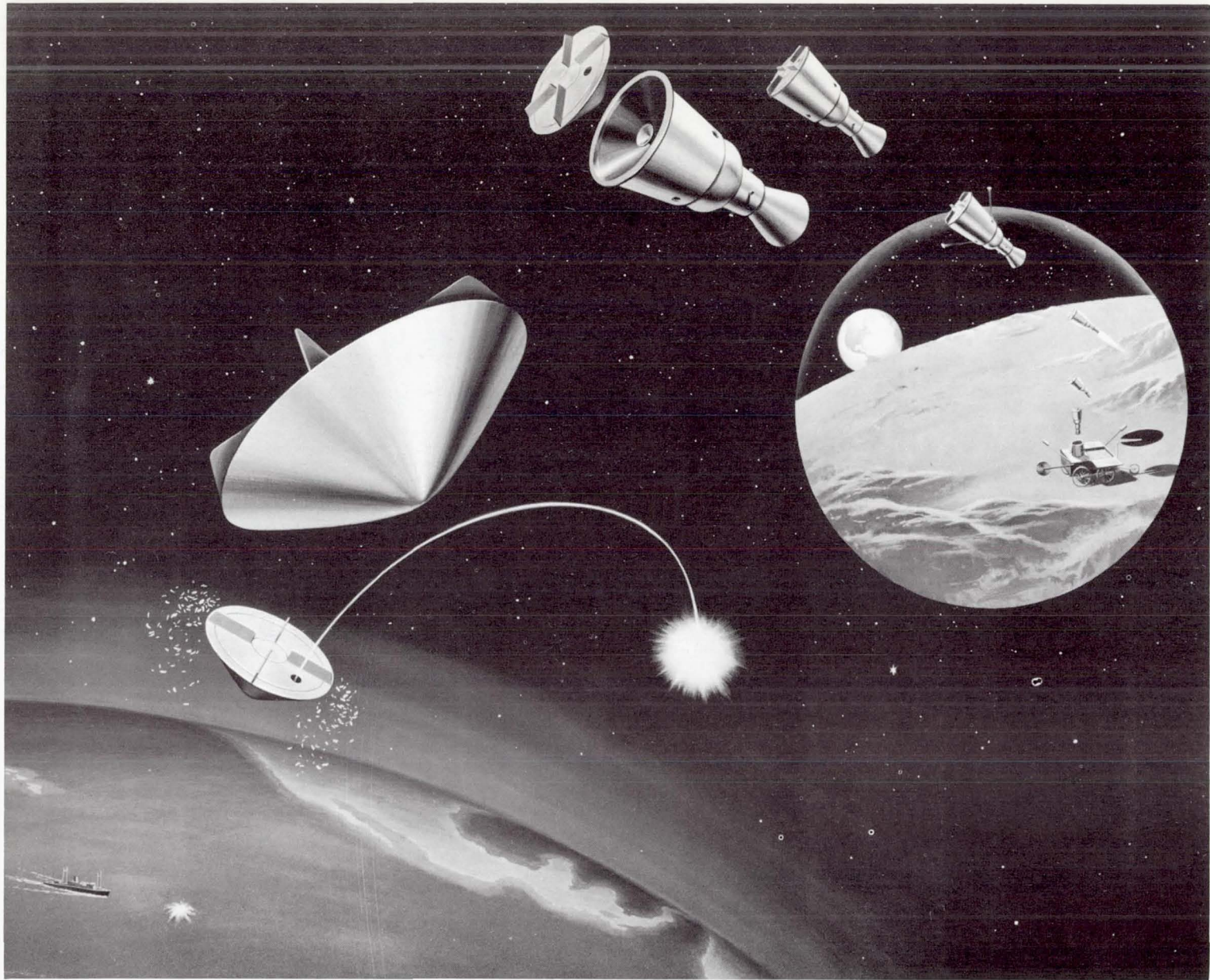

Figure 6. Lunar Mission - Earth Return Vehicle Mission Profile

2) In order to build a correct lunar model, it was very important that the collected scientific information gained from the experiments be properly correlated. An accurate location of the various sample sites must be known.

3) There are certain areas of the moon which are important to the selenologist because of the wealth of information expected in these locals. In order to insure that the Traverser will explore these area, it must be so directed. This requires knowledge of its exact position.

A unique navigation system utilizing star tracking/laser combination is used for accurately locating the Traverser on the moon for navigation purposes.

## Moon—Earth Return Vehicle System

One of the Prospector objectives is to retrieve and transport lunar samples to earth.<sup>1</sup> These samples must be segregated and hermetically contained within the hypervelocity re-entry capsule which will be recovered on earth. In addition to the samples a reel of data storage tape will also be returned to earth.<sup>2</sup>

To achieve these objectives requires a vehicle with the capabilities to:

- 1) Re-enter the atmosphere at hypervelocity (36,000 feet per second-400 g's)
- 2) Recoverable payload
- 3) Boost guide control
- 4) Develop the required lunar escape velocity
- 5) Survive environmental conditions

---

<sup>1</sup> 1/2 pound of samples from each of ten sampling sites.

<sup>2</sup> 3 1/2" dia x 1/2" thick weighing 0.25 pounds

The re-entry capsule will house and protect the payload and recovery aids from re-entry heating. Also, it will be capable of floating and surviving a water impact of 130 g's.

Recovery will be achieved with a high degree of reliability. The reliability of recovery will be dependent primarily on the capabilities of the guidance and control subsystem, the recovery aids, and the recovery task force.

The guidance and control subsystem insures that the re-entry capsule will impact within a given circular error of probability (CEP). The recovery task force capabilities will be confined to a three sigma area dispersion of the re-entry capsule which is 500 nautical miles.<sup>3</sup>

Adequate propulsion will be provided to achieve the required velocity (8500-9500 feet per second  $\pm$  50 feet per second accuracy) to escape lunar gravity and to impact within the earth's designated area. A boost phase subsystem will be provided to maintain the vehicle axes relative to the reference axes during boost.

The return vehicle will be capable of surviving the environment that it will encounter such as vibration, acceleration, temperature, meteorites and others. Some of the vehicle internal components must be protected from the external temperatures existing on the lunar surface.

The results of the study effort indicates that the return vehicle mode of operation and system design should be outlined as follows:

- 
- <sup>3</sup>Tracking requirements permit the following impact predictions:
- 100 nautical miles @ two days before impact
  - 50 nautical miles @ one day before impact
  - 10 nautical miles @ five hours before impact
  - 5 nautical miles just prior to re-entry

## MERV Mission Profile

- 1) Lunar samples are loaded and sealed individually inside ten capsules which are an integral part of the lunar dust and data tape container.
- 2) The sample container is then inserted and secured inside the re-entry capsule.
- 3) The return vehicle is erected vertically and guidance reference settings are made.
- 4) The vehicle is launched from its container by compressed gas to an altitude of 200 feet.
- 5) During the normal part of the vertical ascent, the vehicle is rotated to the reference inertial attitude.
- 6) Whenever the desired altitude and vehicle attitude are reached, the booster motor is ignited.
- 7) The vehicle attitude is controlled during boost phase to insure proper burnout velocity vector.
- 8) When the required burnout velocity magnitude is reached, the thrust is terminated by opening thrust terminating parts on the motor by a linear shape charge (s).
- 9) During the ballistic flight to earth, the vehicle is periodically tracked and impact predictions are made to direct the recovery task force to the predicted impact area.

10) As the vehicle approaches earth, it is separated from the return vehicle (MERV) by earth command signals. However in the event that it will impact over undesirable territory, the re-entry capsule is destroyed.

11) When equilibrium descent is reached, the recovery programmer will eject the radar chaff and high altitude flare beacon.

12) At post impact the programmer ejects the dye marker and activates a UHR beacon. This function completes the return vehicle (MERV) mission.

#### CONFIGURATIONS

1) Envelope size of the proposed launch configuration is 76 inches long by 30.5 inches in diameter.

2) The launch and payload weights are 467 and 157 pounds respectively.

3) The re-entry capsule utilizes a MK-2 proven configuration and ablation type of heat protection system.

4) The re-entry capsule back-face design provides the required aerodynamic stability to eliminate the need of stabilizing the capsule prior to re-entry.

5) The re-entry capsule is separated from the vehicle by a preloaded spring mechanism which is released by an explosive bolt.

6) A C-band ( $f = 2285$  MC) transponder is used to aid earth tracking (five watts - three pounds).



- 7) Redundant receivers are used for the earth to vehicle command link.
- 8) A shaped explosive charge with safeing and arming provisions is located directly behind the re-entry capsule to destroy the re-entry capsule on command for reasons of safety or security.
- 9) An inertial stable platform with an appropriate computer and associated equipments will provide the guidance intelligence during the return vehicle (MERV) boost phase.
- 10) An on-off hot gas reaction attitude control subsystem is used during the boost phase (six nozzles 10-15 pounds).
- 11) A solid fuel spherical motor is used to provide the required lunar escape velocity.
- 12) The booster motor utilizes a linear shaped explosive charge to terminate its thrust.
- 13) A silver zinc battery power supply is used (483 watt-hours-20 pounds).
- 14) Aluminum is utilized throughout the vehicle structure.
- 15) The vehicle outside structure is coated with emissive coating to control the internal temperature during the moon-to-earth trip.
- 16) The vehicle is contained in a thermal insulated cylindrical container which is also used to launch the vehicle.

WEIGHT AND BALANCE STATEMENT

	<u>WT.</u>
Moon Earth Return Vehicle	(467.2)
Structure	33.0
Propulsion	310.0
Electrical Power	20.0
Communications	29.0
Boost Phase Guidance	25.0
Boost Phase Control	10.0
Re-entry Capsule	(40.2)
Structure	4.5
Heat Protection	4.8
Foam	6.2
Beacon XMTR. and Antenna	2.0
Power Supply	6.0
Flashing Light	1.5
Chaff (2)	3.0
Dye Marker (2)	2.0
Programmer	1.0
Data Tape	0.2
Capacitor	1.0
Lunar Samples and Container	8.0

MOMENT OF INERTIA DATA (SLUG FEET<sup>2</sup>)

	$I_{\text{Roll}}$	$I_{\text{Pitch}}$	$I_{\text{Yaw}}$
Re-entry Capsule	0.39	0.24	0.24
Moon Earth Return Vehicle	7.76	26.36	26.36

## Mission Changes Due to C-1, C-2, and Titan III Differences

In the foregoing discussion a mission description using the C-2 vehicle with a lunar soft-landing capability of 4016 pounds was described. If a Titan III high payload vehicle were used as a booster, the payloads could be scaled up in weight to provide for more experiments, greater reliability, or additional payloads. If the C-1 vehicle were used, the Rover/Traverser would be smaller and the number of experiments would be limited. The return vehicle would be sent to the moon on a separate flight to rendezvous with the Rover/Traverser. This is not difficult because the guidance concept permits landing within 1.0 mile  $3\sigma$  of any location on the moon. The television observation on board the Rover/Traverser would provide rendezvous guidance to the return vehicle.

SATURN PROSPECTOR PAYLOADS

	C-1 (Rover Traverser)	C-1 (Return Vehicle)	C-2 (Rover/Tra- verser/Re- turn Vehicle)	Titan III	
Soft-land capa- bility on the moon	1500 lbs.	1500 lbs.	4016 lbs.	1000 - 2000	
Space Truck	530	530	856	530	
Rover/Traverser	853		1390	835	
Return Vehicle		467	467	467	
Experiments or Freight	135		702	135	
Sample Transfer Mechanism		50			
Margin <sup>(1)</sup>	<u>          </u>	<u>453</u>	<u>601</u>	<u>-500</u>	500
Total	1500	1500	4016	x	2000

---

<sup>1</sup> Available to increase the size of the experimental package, logistic payload, or redundancy of subsystem for added reliability, etc.

x Mission can't be performed.

## TEAM ARRANGEMENTS

Because of the broad scope of the Prospector, G. E. has formed a team with selected consultants and members of industry so that the most effective proposal may be presented to the customer. In this respect we have negotiated the following:

### Selenology Support Contract:

Dr. Allen Keller, Professor of Geology, University of Pennsylvania,  
Dr. A. E. Engle, Professor of Geology, University of California

### Nonexclusive Agreements:

<u>Guidance and Control</u>	<u>Team A</u>	<u>Team B</u>	
Mid-course	GE-MSVD	GE-MSVD	
Lunar Terminal	Raytheon	International Telephone and Telegraph	
Lunar Navigation	Sperry	GE-Ordnance Dept.	
Lunar Launch	Sperry	GE-Ordnance Dept.	
<u>Traverser Vehicle</u> <u>(Locomotion)</u>	American Mach. Foundry (Multi- axle Concept)		
	GE-MSVD (Single axle Concept)		
<u>Communications</u>	Raytheon	International Telephone and Telegraph	
<u>Propulsion</u>	<u>Team A</u>	<u>Team B</u>	<u>Team C</u>
Main Retro-Liquid $H_2O_2$	Aerojet	Thiokol	Pratt Whitney
Vernier Retro-Hypergolic	Rocketdyne Thiokol	Bell	Aerojet
Main Retro (Solid)	Thiokol	Aerojet	Rocketdyne