

NASA TECHNICAL NOTE

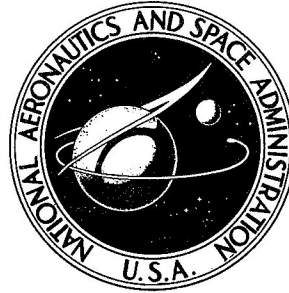

N70-32261

NASA TN D-5773

NASA TN D-5773

CASE FILE  
COPY

MERCURY ELECTROCHEMICAL  
COULOMETER AS A BATTERY  
STATE-OF-CHARGE INDICATOR

*by Richard R. Secunde and Arthur G. Birchenough*

*Lewis Research Center  
Cleveland, Ohio 44135*

1. Report No. NASA TN D-5773	2. Government Accession No.	3. Recipient's Catalog No.	
4. Title and Subtitle MERCURY ELECTROCHEMICAL COULOMETER AS A BATTERY STATE-OF-CHARGE INDICATOR		5. Report Date July 1970	
		6. Performing Organization Code	
7. Author(s) Richard R. Secunde and Arthur G. Birchenough		8. Performing Organization Report No. E-5331	
9. Performing Organization Name and Address Lewis Research Center National Aeronautics and Space Administration Cleveland, Ohio 44135		10. Work Unit No. 120-27	
		11. Contract or Grant No.	
12. Sponsoring Agency Name and Address National Aeronautics and Space Administration Washington, D. C. 20546		13. Type of Report and Period Covered Technical Note	
		14. Sponsoring Agency Code	
15. Supplementary Notes			
16. Abstract Use of a mercury-column electrochemical coulometer is discussed as a means for indicating the state of charge of secondary-battery systems through ampere-hour integration. The general nonlinear charge-discharge characteristics of a battery were matched through the use of operational-amplifier techniques. Results of electrical and temperature tests demonstrate that a coulometer of this type is a feasible device around which a battery state-of-charge indicator might be built.			
17. Key Words (Suggested by Author(s)) State of charge indicator Battery Coulometer		18. Distribution Statement Unclassified - unlimited	
19. Security Classif. (of this report) Unclassified	20. Security Classif. (of this page) Unclassified	21. No. of Pages 18	22. Price * \$3.00

\*For sale by the Clearinghouse for Federal Scientific and Technical Information  
Springfield, Virginia 22151

# MERCURY ELECTROCHEMICAL COULOMETER AS A BATTERY

## STATE-OF-CHARGE INDICATOR

by Richard R. Secunde and Arthur G. Birchenough

Lewis Research Center

### SUMMARY

Use of a mercury-column electrochemical coulometer is discussed as a means of indicating the state of charge of secondary batteries. A state-of-charge indicator was designed, built in breadboard form, and tested. The coulometer is the element which integrates the ampere-hours into and out of the battery. The state of charge then is the difference between the known fully charged battery capacity and the net ampere-hours removed. The general nonlinear charge-discharge characteristics of a battery were matched through the use of operational-amplifier techniques.

The results of electrical and temperature tests on the breadboard of the indicator demonstrate that the mercury-column coulometer is a feasible device around which a battery state-of-charge indicator suitable for space power systems, or other uses, might be built.

### INTRODUCTION

The major applications of space secondary-battery systems in the past have been in space vehicles that operated in a known orbit or flight and had a known electrical load. Battery size, system integration, and charge control were primary considerations in the design of these systems. The actual state of charge of the battery at any one time was of lesser importance because the system could be designed for the known application. However, in future higher power systems which will be used for manned space stations or interplanetary missions, batteries will serve as backup or emergency power supplies. The electric load and the use of the batteries in these higher power systems are not predictable. A method to indicate the state of charge of a battery will aid in crew safety and mission success by providing continuous information on the amount of energy available. Such an indicator would be used in a manner similar to a fuel gage.

At present, there does not appear to be a practical method to measure and indicate state of charge directly from battery parameters. The most feasible approach at this time is that of using some form of ampere-hour device to integrate the ampere-hours into and out of the battery. When the charge-discharge characteristics of a battery are known and the ampere-hour device is designed to match them properly, the value of the charge-discharge current-time integral is a good indication of the state of the charge.

One form of ampere-hour device uses a stepping motor and a potentiometer. However, the sliding contacts of that scheme may compromise its life and reliability. Complex solid-state digital circuits have also been used. The electrochemical coulometer is another type of ampere-hour device. Some coulometers, such as those described in reference 1, indicate full-charge conditions only. The type considered in this report consists of a sealed glass tube containing two columns of mercury separated by a gap containing an electrolyte and is referred to as a mercury column coulometer. The linear position of the gap in the tube is an indication of the ampere-hour integral.

In the past, mercury-column coulometers have been studied for use in space battery systems. But it was found that the shock and vibration which would exist during the launch of space vehicles such as GEOS and Transit caused the mercury to bridge the electrolyte gap (unpublished data from Louis Wilson and Eugene Stroup, both of NASA Goddard Space Flight Center). The electrolyte dispersed through the mercury, and the gap and integrating capability of the coulometer were lost. The design of mercury-column coulometers has changed since these problems were observed. More recently, they have survived the shock and vibration present during launching and operated successfully in destruct timers in several operational satellites (unpublished data from Franklin Kelly, TRW Systems Group, Redondo Beach, California). In a timer, a constant current flows through the coulometer, and the gap moves at a constant rate along the bore of the glass tube. When the gap reaches the end of the tube, the impedance of the coulometer changes significantly. This change in impedance is the indication that a predetermined time period has elapsed.

The mercury-column coulometer is relatively simple. Its operation is not affected by a vacuum environment or the absence of gravity. These features, together with its more recent successful operation in satellite systems, indicate that it should be considered for use in larger space power systems.

For this investigation, general charge-discharge characteristics were developed from data on vented aircraft batteries (ref. 2). A commercially available mercury-column coulometer was designed into a state-of-charge indicator matched to these characteristics. Some coulometers of this type give direct visual readout of gap position. However, for greater accuracy and applicability to space systems, a coulometer with an electronic readout circuit was used. The state-of-charge indicator circuit was built and tested in breadboard form so that its accuracy, stability, and overall electrical performance could be determined.

This report evaluates the mercury-column coulometer as a means of indicating battery state of charge by the ampere-hour method. It also describes the electronic circuitry necessary in order to use this coulometer in a space power system.

## STATE-OF-CHARGE INDICATOR

### Coulometer

Figure 1 shows the mercury-column electrochemical coulometer in a simplified form. It consists of a sealed glass capillary tube with an electrode at each end and filled

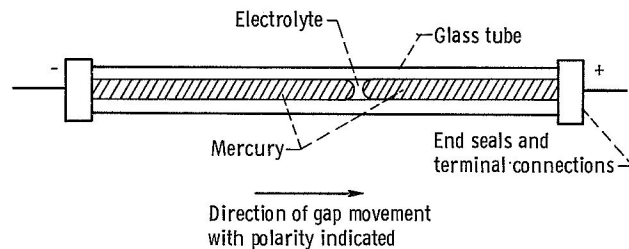

Figure 1. - Simplified view of mercury-column coulometer.

with mercury except for a small gap formed by a liquid electrolyte. The gap separates the mercury into two columns. When a current is passed through the coulometer, mercury will be electrochemically transferred from one column across the electrolyte gap to the other column. The amount of mercury transferred is proportional to the time integral of current through the coulometer. As the mercury transfers from one column to the other, the lengths of the columns change and the gap moves along the length of the coulometer. The position of the gap, then, is an indication of the time integral of current, or ampere-hours. References 3 and 4 provide a more complete description of this type coulometer. The coulometer used for the state-of-charge indicator described in this report was approximately 1.0 centimeter long and 0.5 millimeter in diameter. It was capable of operation over an ambient temperature range of  $-20^{\circ}$  to  $85^{\circ}$  C. These limits are imposed by the freezing point of the electrolyte and by the end-seal construction. The maximum allowable current through the coulometer used was 2.0 milliamperes. Excessive current causes turbulence in the gap and can result in mercury flow around the gap. If this happens, the gap separates into several small sections and the integrating action is lost.

## Use in Electric Power Systems

Figure 2 illustrates the use of an ampere-hour type state-of-charge indicator in a dc power system. The indicator monitors the total battery current, both charge and discharge, and provides an electrical output signal, or other indication, proportional to the

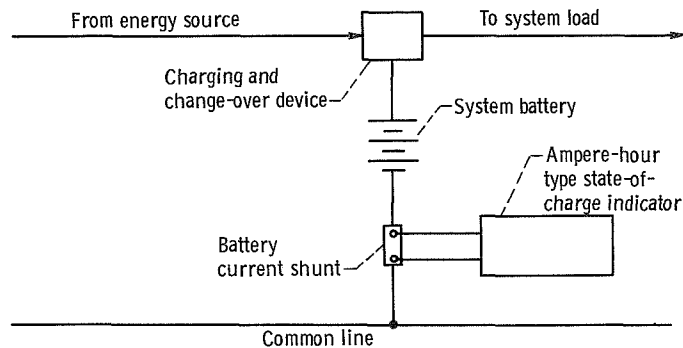

Figure 2. - Use of ampere-hour type battery state-of-charge indicator.

time integral of that current. This time integral is the net charge in ampere-hours into and out of the battery. The battery state of charge is the ampere-hours available at a standard discharge rate from the battery at the time in question. Therefore, when the indicator is set to some predetermined output reading when the battery is known to be fully charged, the changed output reading at any time after that is an indication of the battery state of charge at that time. Occasionally the indicator must be reset to allow for its inability to compensate for changes in battery capacity caused by age, cycling, and varying rates of charge and discharge. If the indicator could be designed to compensate for these changes, the need for resetting would be less frequent or eliminated altogether. The indicator described in this report was designed to compensate for some of these characteristics, namely, the charge-discharge ampere-hour efficiency of a battery, and for capacity variation caused by varying discharge rates. With additional circuitry, the coulometer might also compensate for variations in capacity which result from other causes.

### Description of Operation

Overall circuit. - In a simple application, the coulometer element could be placed in series with the battery, and the gap observed visually to determine the battery charge. Although this is conceptually possible, there are several limitations.

The ampere-hour capacity of the battery must match the full-scale ampere-hour capacity of the coulometer. The coulometer capacity is generally much smaller, normally 5 or 10 milliampere-hours. And, the peak current in the coulometer is limited to a value far below the peak current of a battery. Because of the limited peak current, the gap position changes slowly and cannot accurately record rapid battery discharges. Also, the coulometer indication is a linear function of the current-time integral. The battery, on the other hand, has a reduced capacity at high discharge rates. It also requires more ampere-hours to recharge than were removed during discharge. These nonlinearities are all temperature dependent. The discharge rate, recharge inefficiency, and thermal characteristics of secondary batteries are discussed in more detail in reference 5.

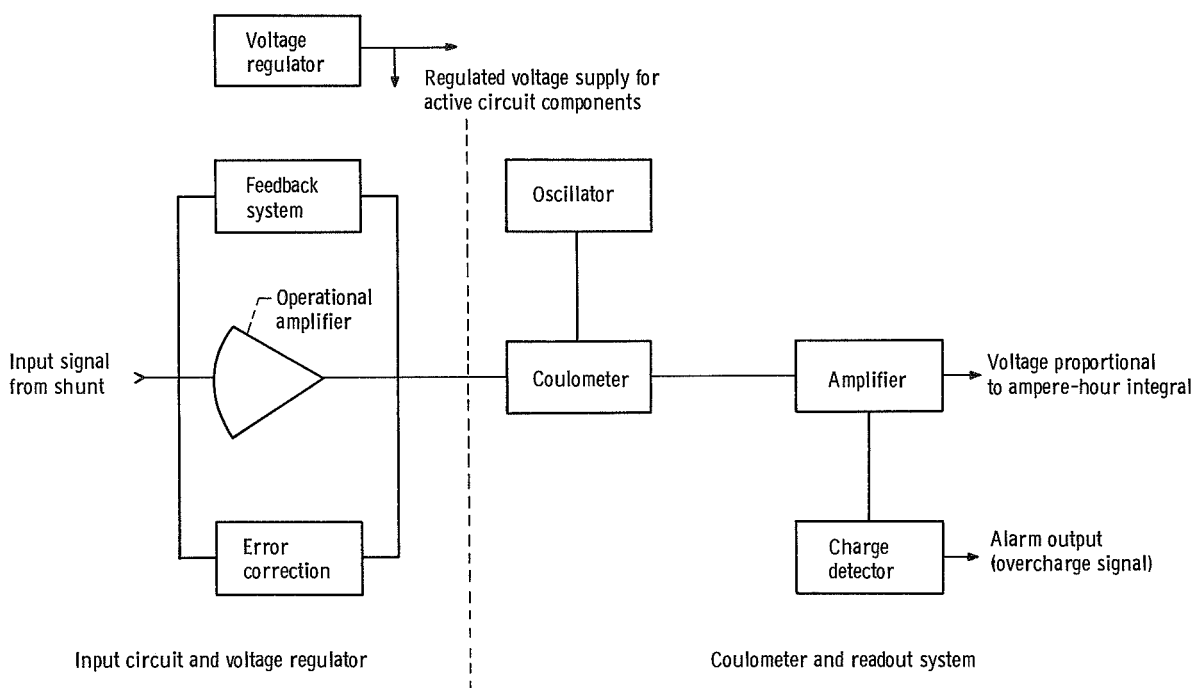

Figure 3. - Block diagram state of charge indicator.

A more practical state-of-charge device is shown in block diagram form in figure 3. Current sensing is accomplished by a low resistance ammeter shunt connected in series with the battery, as in figure 2. All battery currents, charge and discharge, must flow through the shunt. The voltage drop across the shunt is fed to the input circuit, which converts the shunt voltage to a current to be integrated by the coulometer. The ratio of this conversion is called transconductance. The primary component of the input circuit is an amplifier with a controlled feedback network that determines its transconductance, which is a nonlinear function of the input to compensate for nonlinearities of the monitored battery. Also included in the input circuit is an error correction network. This

network offsets the amplifier drift which would otherwise introduce a slight current in the coulometer even though the amplifier input is zero. Amplifier saturation and a series resistor are used to limit the peak current in the coulometer.

The ability of the coulometer to record rapid discharges is improved by having only a small displacement of the gap correspond to the full battery capacity. If the amount of mercury which must be moved to indicate the change from zero to full charge is reduced, without changing the peak coulometer current, the minimum time for a full-scale change will be reduced. The integrating rate is then effectively increased.

The oscillator and amplifier are required for the electronic readout of the gap position. A charge detector is also included to provide an output at any predetermined battery charge indication, which can be used to control overcharge or warn about excessive discharging. The various circuits operate from regulated voltages, supplied by simple series transistor regulators.

Input circuit. - The input circuit of this ampere-hour meter (fig. 4) conditions the signal from the shunt and applies it to the coulometer. In a simple form, the input circuit could consist of an ammeter shunt to sense the current and an adjustable resistor in series with the coulometer for calibration. But, for increased accuracy, obtained by more closely matching the battery characteristics, the more complicated active circuit shown in figure 4 was used. The appendix gives a complete parts list for this circuit.

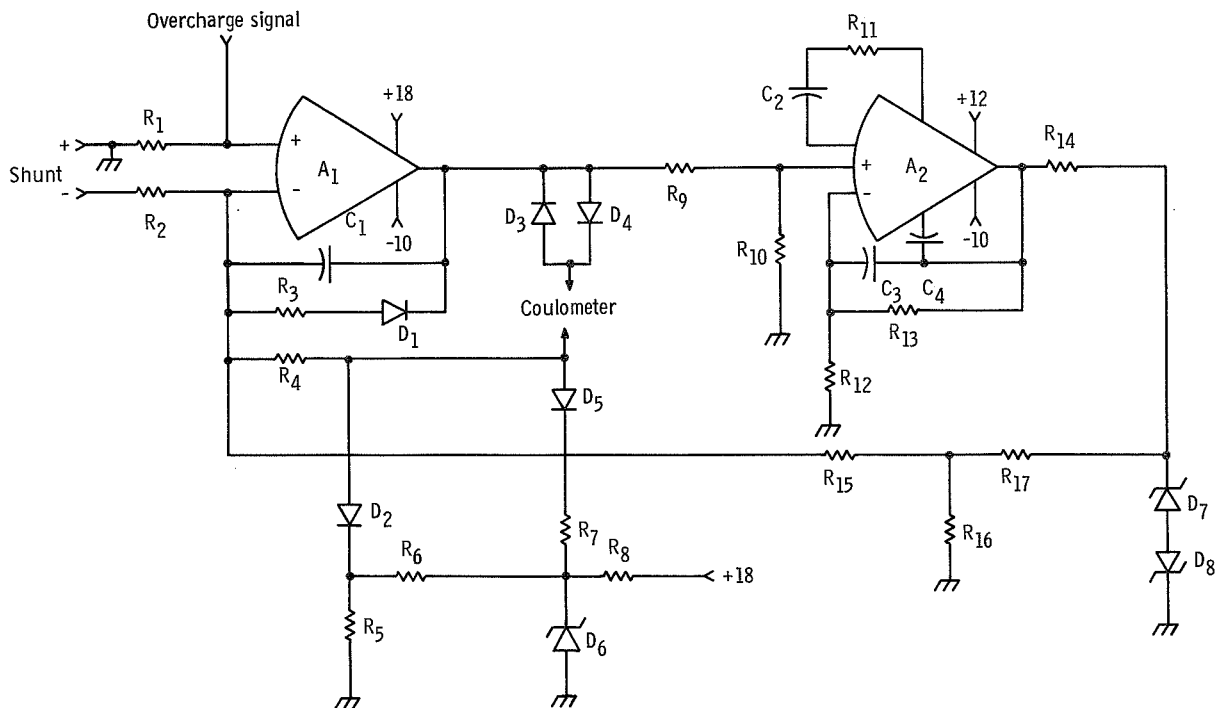

Figure 4. - Input circuit.



Amplifier  $A_1$  is a high-gain operational amplifier in a feedback loop designed so that its two differential inputs are at very nearly the same voltage. The noninverting input (the output is in phase with this input) is connected to ground through resistor  $R_1$ , which is included only to improve the drift stability of amplifier  $A_1$  and has no other effect on circuit operation. The high-gain and feedback loops assure that the inverting input is also near ground potential, so that the shunt voltage appears across  $R_2$  and generates a current through  $R_2$ . This current is balanced by an opposite current flowing in the feedback resistors  $R_3$ ,  $R_4$ , and  $R_{15}$ . Most of this current flows through  $R_4$  and the coulometer; so the coulometer current is nearly proportional to the shunt voltage. The shunt is connected so that the voltage developed by a discharge current has the polarity marked in figure 4, which causes the output of  $A_1$  to be positive. As the shunt voltage increases, because of a higher discharge rate, the current through  $R_2$ , and therefore  $R_4$ , increases. When the voltage drop across  $R_4$  reaches the level set by  $R_5$ ,  $R_6$ ,  $R_8$ , and diode  $D_6$ ,  $D_2$  starts to conduct. Thus, the coulometer current is greater than the current through  $R_4$ . The effect of this increased current is to reduce the apparent integrator capacity at high current levels, simulating the actual decline in battery capacity at high discharge rates. At still higher current levels, where the battery capacity decreases further, additional current also flows through  $D_5$  and  $R_7$  and further increases the transconductance. By adjusting the components in these diode curve shaping networks, the transconductance curve can be varied to compensate for characteristics of other batteries.

When the battery is charging, the shunt voltage is reversed, and current flow in the coulometer is reversed. Also, there is a current path, in parallel with the coulometer, through  $D_1$  and  $R_3$ , that reduces the coulometer current. Therefore, more millivolt-hours (A-hr) are required to reset the coulometer than it recorded during discharge. This compensates for the recharge inefficiency of the battery.

The input circuit also includes an error correction network to minimize errors caused by the offset voltage of the operational amplifier  $A_1$ . All dc amplifiers exhibit an offset voltage which changes as a function of the time, temperature, and supply voltage. This offset voltage causes a nonzero output voltage when the input is zero. If this offset is not canceled, there will be a small current in the coulometer when there is no input. This will cause the state-of-charge indication to change even though the battery is not being charged or discharged. The error correction network consisting of amplifier  $A_2$  and associated components provides the necessary cancellation.

Any voltage at the output of  $A_1$  is amplified by  $A_2$  and applied as negative feedback to the input of  $A_1$ , and the output of  $A_1$  is thereby reduced to nearly zero. But the maximum current which can be fed back is limited by  $R_{15}$ ,  $R_{16}$ ,  $R_{17}$ ,  $D_7$ , and  $D_8$ . And because the feedback current is small, only small corrections can be made. The signal generated at the shunt, which is generally large compared to the offset voltage, will cause a current to flow in the coulometer as required for normal operation.

Readout system. - Because of the small gap displacement required for fast integrating, visual readout was impractical. Therefore, an electronic gap position detector was used to provide an electrical output signal proportional to the gap position. The readout technique is described in detail in reference 4. It is basically a variable capacitance voltage divider, as shown in figure 5. A conductive sheath is wrapped around the capillary tube, and a high-frequency signal  $e_{in}$  is applied across the coulometer. The ac voltage between the sheath and the lower electrode  $e_{out}$  (fig. 5) is proportional to the

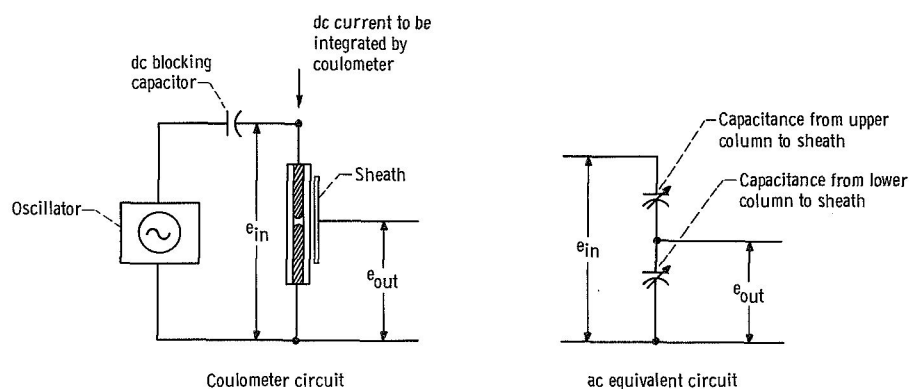

Figure 5. - Electronic readout system.

gap position because the capacitance between the sheath and each mercury column changes as the column length changes. The voltage on the sheath is amplified, rectified, and used to drive a voltmeter which indicates the integrated ampere-hours.

## APPARATUS AND PROCEDURE

A state-of-charge indicator using the circuit shown in figure 4 and designed to operate with a generalized nickel-cadmium secondary battery was assembled in breadboard form for testing. The coulometer and its gap-position-detecting readout circuit were obtained commercially. The readout circuit was modified to accommodate voltage supply, grounding, and return current path requirements. The original carbon composition resistors in critical parts of the readout were replaced by resistors of the metal-film type in order to improve temperature stability.

The breadboard, including voltage regulators for the operational amplifiers, coulometer, and readout circuit, weighed 165 grams and had a volume of 55 cubic centimeters. Power for operation of the breadboard was furnished by laboratory-type dc supplies.

The input signal to the state-of-charge indicator is a voltage in the millivolt range

which would be provided by the current shunt in an actual system (see fig. 2). For the tests described in this report the input voltage was obtained from a low voltage supply.

The performance of the state-of-charge indicator was experimentally evaluated on both the subcircuit and overall circuit levels. The ability of the input circuit to compensate for the charge-discharge characteristics of a battery was checked by experimentally determining its transconductance characteristic. The linearity of the output signal from the coulometer and its readout circuit was experimentally determined so that a linear operating range could be selected. The overall circuit was tested at various ambient temperatures to verify its ability to provide an output signal which is a good indication of battery state of charge, as would be determined from the general charge-discharge characteristics. Finally, the overall circuit was tested to determine the stability of its output signal with time and with ambient temperature. These stability tests were made with the input voltage at zero. Any change in output would be caused by drift or temperature dependence. The breadboard circuit was placed in a small controlled temperature chamber for all temperature tests.

## RESULTS AND DISCUSSION

### Subcircuit Performance

Input circuit. - In order to function satisfactorily as a battery state-of-charge indicator, the ampere-hour type circuit must compensate for the important discharge-rate characteristic of the battery. As mentioned earlier, this requires the input circuit to have a variable transconductance (current to coulometer/input voltage), which is a function of the input voltage. Figure 6 shows the experimentally determined discharge transconductance of the input circuit normalized to the transconductance at the 100-millivolt input level. For this report, an input voltage of 100 millivolts represents a battery current that would completely discharge the battery in 1 hour (the 1-hr rate). As the figure shows, higher input voltages result in higher transconductance.

Coulometer and readout. - The coulometer and its readout circuit should provide an output voltage which has a linear relation to the microampere-hours integrated by the coulometer. Such a linear output will allow simple conversion factors in control or telemetry systems. Figure 7 shows the experimentally determined output voltage as a function of millivolt-hours. The indicated linear portion is the selected operating range representing zero to full battery charge. That is, an output reading of 7 volts represents full charge and a reading of 4.4 volts represents zero charge. A different voltage swing could be obtained by a different design for the readout circuit.

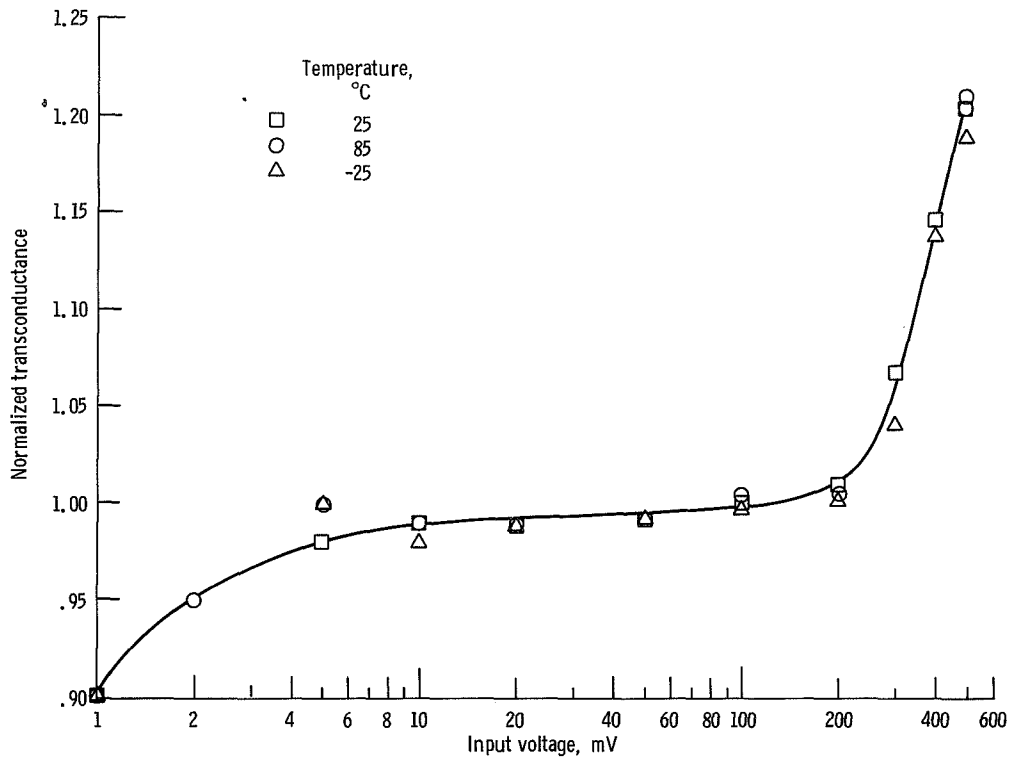

Figure 6. - Input circuit transconductance for battery discharge (current to coulometer/input voltage).

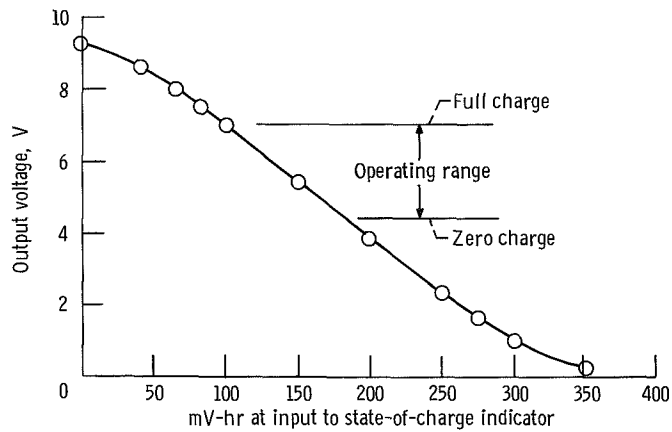

Figure 7. - Coulometer and readout circuit output voltage as function of millivolt-hours at constant input voltage.

## Complete Indicator Circuit Performance

Performance as compensated ampere-hour integrator. - Figure 8 shows the experimentally determined operating characteristics of the complete state-of-charge indicator normalized to the capacity at the 1-hour discharge rate (100-mV input). These characteristics match the general charge-discharge characteristics of a secondary battery. Higher discharge rates produce a higher millivolt drop across the battery shunt and therefore a higher voltage into the state-of-charge indicator. At these higher discharge rates, fewer ampere-hours will bring the battery to zero state-of-charge. Similarly, fewer millivolt-hours are needed to drive the state-of-charge indicator to zero charge indication.

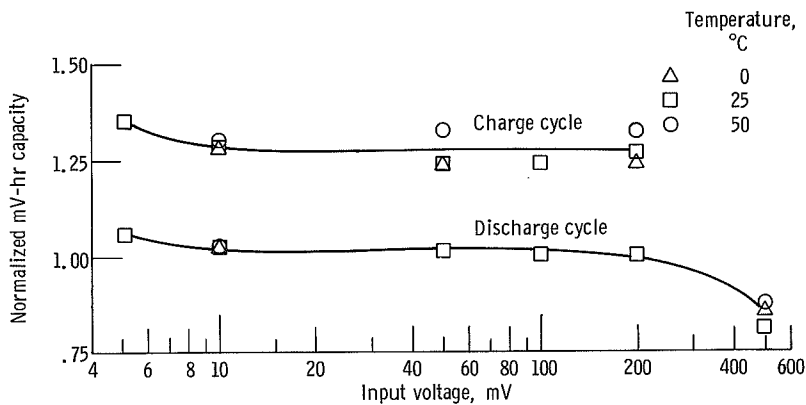

Figure 8. - Operating characteristics of state-of-charge indicator. (Normalized mV-hr are mV-hr necessary to change output over full range.)

As figure 8 also shows, in the device tested, approximately 25 percent more millivolt-hours, and therefore battery ampere-hours, are required in the charging cycle to drive the state-of-charge indicator back to the full-charge indication than were required initially to drive it to the full-discharge indication. This ratio can be readily changed for a different type of battery by selecting a different value for resistor  $R_3$  in the input circuit (fig. 4).

The increase in normalized millivolt-hours at low input voltages is partially caused by the error correction network in the input circuit. This network causes a dead band of approximately 200 microvolts near zero input. This dead band is an effective reduction in the input voltage. At 5 millivolts input, the maximum error caused by the dead band would be 4 percent. The error is less at higher inputs, being a maximum of 2 percent at 10 millivolts, or the 10-hour rate. It is expected that, in normal use, battery discharge will occur at rates faster than the 10-hour rate. The remainder of the rise shown at low

input voltages results from small measurement errors accumulated during the long times necessary for full indicator output change.

The power required by the state-of-charge indicator as measured during performance tests is approximately 0.9 watt from a nominal  $\pm 28$ -volt source. This includes the loss in the voltage regulators used to supply the operational amplifiers and readout circuit.

The coulometer could be reset to any reading within the operating range by applying a suitable voltage to the input circuit. Resetting over the complete zero-to-full-charge range could be accomplished in approximately 5 minutes. The maximum allowable current in the coulometer is the factor which limits the speed at which resetting can be accomplished.

Time and temperature stability. - A series of 100-hour tests at various ambient temperatures provided data on the stability of the state-of-charge indicator with time. For these tests the output indication voltage was brought to a set value, and the input voltage was held at zero (simulating no use of the battery). Table I shows the results of the series of 100-hour time-stability tests at various ambient temperatures and output voltages. The maximum spread in output voltage measured was 51 millivolts, or less than 2 percent of full scale. Full scale is the output voltage change from 0 to 100 percent state-of-charge indication (2.6 V). The spread in output voltage with time could have been caused by small variations in component performance at the low current and voltage levels in the circuit. The spread consisted of excursions from the nominal value. These excursions lasted anywhere from a few minutes to about an hour. No significant permanent change in

TABLE I. - EXPERIMENTAL DATA FOR TIME  
STABILITY OF STATE-OF-CHARGE  
INDICATOR IN 100-HOUR TESTS

Ambient temperature, °C	Indicator output, V (a)	Maximum spread of output, mV (b)	Excursion, percent of full range (c)
25	6.5	42	1.62
25	4.0	22	.85
50	4.0	51	1.96
0	4.25	21	.81

<sup>a</sup>Input to indicator was zero during test.

<sup>b</sup>Spread is difference between maximum and minimum values.

<sup>c</sup>Full range is 2.6 V (4.4 to 7.0 V output).

the output was apparent. The calculated drift is less than 1 percent per 1000 hours.

Figure 9 shows the temperature stability, or variation in indicated state-of-charge with ambient temperature, of the breadboard state-of-charge indicator. For these tests, the output voltage (state-of-charge indication) was set at values near the zero charge and full charge levels at 25<sup>o</sup> C. For each voltage the circuit was operated at various ambient temperatures with zero input voltage. The change in output voltage from that set at 25<sup>o</sup> C was measured at each ambient temperature.

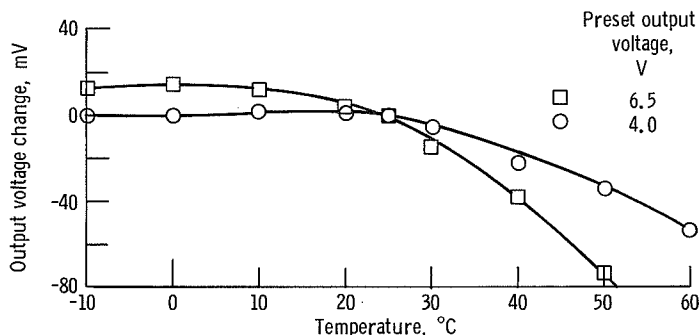

Figure 9. - Temperature dependence of state-of-charge indicator output voltage (with zero input voltage).

The stability at lower temperatures is good. However, the change in output voltage at temperatures above 30<sup>o</sup> C is not as good, but still of the order of 3 percent of full range. The output voltage returned to the set value when the ambient temperature was returned to 25<sup>o</sup> C. Dimensional changes in the coulometer with temperature and/or temperature sensitivity of the output circuit could have caused the change in output voltage.

The stability of the integrating ability of the coulometer with ambient temperature variation was checked. To do this, an initial reading of the readout output voltage was taken. A number of microampere-hours were integrated by the coulometer at 25<sup>o</sup> C. The ambient temperature was then changed to 50<sup>o</sup> C, and the same number of microampere-hours integrated in the reverse direction. After completion of the integration at 50<sup>o</sup> C, the ambient temperature was returned to 25<sup>o</sup> C. The final output voltage reading at 25<sup>o</sup> C was within 0.1 percent of the initial reading. Therefore, the integrating ability does not appear to be affected by ambient temperature variation.

## Design Improvements

The temperature sensitivity and operating range of the ampere-hour meter are determined mainly by the coulometer. Different electrolytes and packaging could change or

extend the operating range, but holding the coulometer temperature constant would also improve the temperature sensitivity of the circuit. Because of the very low power dissipation in the coulometer (less than 1 mW), temperature regulation should not be difficult. Alternatively, some improvement in the output-voltage temperature dependence would also be gained by operating over a greater length of the coulometer, but this also reduces the maximum integrating rate. The input circuit is almost independent of temperature, but the readout circuit would require some redesign to reduce its temperature sensitivity.

Battery temperature and cycle history also affect the capacity of the battery. Temperature-sensitive components could be added to compensate for the battery temperature, but the battery-life compensation would require a cycle counter or some other life-determining circuit. When incorporating a large number of variables in the design, it may be an advantage to use an analog multiplier to obtain variable transconductance instead of the diode curve-shaping network in the feedback loop.

Output-voltage detectors can be easily incorporated which sense full-charge or other output-voltage levels to control external equipment. A detector was incorporated in the breadboard to stop the integration at full charge. This would be useful to permit a controlled amount of overcharging of the battery to ensure full charge in cases where there might be an unpredictable drift in the battery characteristics. The detector also prevented the gap from moving to the end of the coulometer, which would have destroyed its integrating capability. Signals can also be easily fed into the circuit to reset it at any time.

The dead band and small signal accuracy of the input circuit are determined by the input operational amplifier  $A_1$ . The dead band must be large enough to compensate for any input offset in the amplifier. More stable amplifiers will permit a smaller dead band and greater low signal accuracy.

The breadboard used in this investigation had a volume of 55 cubic centimeters. This volume could be reduced considerably through the use of integrated circuits and thick-film techniques in the design of the indicator.

## CONCLUDING REMARKS

Successful operation of mercury-column coulometers as timers in operational satellites indicates that earlier shock and vibration problems have been overcome. The use of a mercury-column coulometer was investigated as an ampere-hour type of state-of-charge indicator for secondary batteries. Such an indicator was designed, built, and tested in breadboard form. The results of electrical and temperature tests demonstrate that the mercury-column coulometer is a feasible device around which a battery state-of-charge indicator suitable for space power systems, or other uses, might be built.



The current-drive requirements of the coulometer can be matched to the nonlinear charge-discharge characteristics of a battery through the use of operational-amplifier techniques in the input circuit. The effect of varying ambient temperature on the performance of the indicator was 3 percent and could be reduced, if required, through incorporation of temperature-compensation circuits. An error correction circuit balanced the amplifier offsets, keeping the drift of the state-of-charge indication to within 2 percent error in 100-hour tests at various temperatures. Further work to investigate the performance of the coulometer and overall indicator under launch and space environmental conditions is recommended.

Lewis Research Center,  
National Aeronautics and Space Administration,  
Cleveland, Ohio, October 21, 1969,  
120-27.

## APPENDIX - PARTS LIST FOR AMPERE-HOUR METER INPUT CIRCUIT

A <sub>1</sub>	Operational amplifier: maximum offset voltage, 100 $\mu$ V, with 1 k $\Omega$ source impedance; gain 10 <sup>4</sup> min with 10 k $\Omega$ load	R <sub>1</sub>	1 k $\Omega$ $\pm$ 1% metal film, 1/2 W
		R <sub>2</sub>	1 k $\Omega$ $\pm$ 1% metal film, 1/2 W
		R <sub>3</sub>	100 k $\Omega$ $\pm$ 1% metal film, 1/2 W
A <sub>2</sub>	709 type operational amplifier	R <sub>4</sub>	17.9 k $\Omega$ $\pm$ 1% metal film, 1/2 W
C <sub>1</sub>	0.1 $\mu$ F, 200 V	R <sub>5</sub>	150 k $\Omega$ $\pm$ 1% metal film, 1/2 W
C <sub>2</sub>	0.005 $\mu$ F, 1 kV	R <sub>6</sub>	600 k $\Omega$ $\pm$ 1% metal film, 1/2 W
C <sub>3</sub>	0.1 $\mu$ F, 10 V	R <sub>7</sub>	40 k $\Omega$ $\pm$ 1% metal film, 1/2 W
C <sub>4</sub>	180 pF, 1 kV	R <sub>8</sub>	180 k $\Omega$ $\pm$ 10%, 1/4 W
D <sub>1</sub>	IN459	R <sub>9</sub>	10 k $\Omega$ $\pm$ 10%, 1/4 W
D <sub>2</sub>	IN459	R <sub>10</sub>	10 k $\Omega$ $\pm$ 10%, 1/4 W
D <sub>3</sub>	IN459	R <sub>11</sub>	1.5 k $\Omega$ $\pm$ 10%, 1/4 W
D <sub>4</sub>	IN459	R <sub>12</sub>	4.7 k $\Omega$ $\pm$ 10%, 1/4 W
D <sub>5</sub>	IN459	R <sub>13</sub>	6.8 M $\Omega$ $\pm$ 10%, 1/4 W
D <sub>6</sub>	IN753	R <sub>14</sub>	10 k $\Omega$ $\pm$ 10%, 1/4 W
D <sub>7</sub>	IN753	R <sub>15</sub>	10 M $\Omega$ $\pm$ 10%, 1/4 W
D <sub>8</sub>	IN753	R <sub>16</sub>	10 k $\Omega$ $\pm$ 10%, 1/4 W
		R <sub>17</sub>	47 k $\Omega$ $\pm$ 10%, 1/4 W

## REFERENCES

1. Haines, R. L.; Henderson, I. H. S.; McKague, F/L J. R.; and King, T. E.: Coulometric Control of Charging of Ni-Cd Secondary Batteries. Proceedings 20th Annual Power Sources Conference, May 24-26, 1966, pp. 109-112.
2. Anon.: Data Sheet on Nickel Cadmium Aircraft Batteries. GEA-7972, General Electric Co.
3. Corrsin, L.: Operating Time Indicator. Patent No. 3,045,178, United States, July 17, 1962.
4. Marwell, E. M., et al.: Electro-Chemical Coulometer Including Differential Capacitor Measuring Elements. Patent No. 3,225,413, United States, June 7, 1966.
5. Bauer, Paul: Batteries for Space Power Systems. NASA SP-172, 1968.

FIRST CLASS MAIL



POSTAGE AND FEES PAID  
NATIONAL AERONAUTICS AND  
SPACE ADMINISTRATION

POSTMASTER: If Undeliverable (Section 158  
Postal Manual) Do Not Return

*"The aeronautical and space activities of the United States shall be conducted so as to contribute . . . to the expansion of human knowledge of phenomena in the atmosphere and space. The Administration shall provide for the widest practicable and appropriate dissemination of information concerning its activities and the results thereof."*

— NATIONAL AERONAUTICS AND SPACE ACT OF 1958

## NASA SCIENTIFIC AND TECHNICAL PUBLICATIONS

**TECHNICAL REPORTS:** Scientific and technical information considered important, complete, and a lasting contribution to existing knowledge.

**TECHNICAL NOTES:** Information less broad in scope but nevertheless of importance as a contribution to existing knowledge.

**TECHNICAL MEMORANDUMS:** Information receiving limited distribution because of preliminary data, security classification, or other reasons.

**CONTRACTOR REPORTS:** Scientific and technical information generated under a NASA contract or grant and considered an important contribution to existing knowledge.

**TECHNICAL TRANSLATIONS:** Information published in a foreign language considered to merit NASA distribution in English.

**SPECIAL PUBLICATIONS:** Information derived from or of value to NASA activities. Publications include conference proceedings, monographs, data compilations, handbooks, sourcebooks, and special bibliographies.

**TECHNOLOGY UTILIZATION PUBLICATIONS:** Information on technology used by NASA that may be of particular interest in commercial and other non-aerospace applications. Publications include Tech Briefs, Technology Utilization Reports and Notes, and Technology Surveys.

*Details on the availability of these publications may be obtained from:*

**SCIENTIFIC AND TECHNICAL INFORMATION DIVISION  
NATIONAL AERONAUTICS AND SPACE ADMINISTRATION  
Washington, D.C. 20546**