

FATIGUE AND FAIL-SAFE DESIGN FEATURES OF THE DC-10 AIRPLANE

By M. Stone
Douglas Aircraft Company
McDonnell Douglas Corporation
Long Beach, California, U.S.A.

N72-29899

SUMMARY

The philosophy and methods used in the design of the DC-10 aircraft to assure structural reliability against cracks under repeated service loads are described in detail. The approach consists of three complementary parts: (1) the structure is designed to be fatigue resistant for a crack-free life of 60 000 flight hours; (2) inasmuch as small undetected cracks could develop from other sources, such as material flaws and manufacturing preloads, the structure also is designed to arrest and control cracks within a reasonable service-inspection interval; and (3) a meaningful service-inspection program has been defined on the basis of analysis and test experience from the design development program. This service-inspection program "closes the loop" to assure the structural integrity of the DC-10 airframe. Selected materials, fasteners, and structural arrangements are used to achieve these design features with minimum structural weight and with economy in manufacturing and maintenance. Extensive analyses and testing were performed to develop and verify the design.

The basic design considerations for fatigue-resistant structure are illustrated in terms of material selection, design loads spectra, methods for accurate stress and fatigue damage analysis, and proven concepts for efficient detail design. Special emphasis is given to the DC-10 development test program. The initial stage of this program was a series of screening tests of candidate materials, types of fasteners, stress coining, surface treatments, manufacturing processes, and so forth.

INTRODUCTION

The structural design goals for the DC-10, shown in figure 1, were to produce an airplane that is superior to the DC-8 and DC-9 and that will be operated safely and economically for at least 20 years. Three complementary criteria were established to assure this goal:

(1) The structure has a crack-free life of 60 000 flight hours on the basis of design, analysis, and tests in excess of 120 000 flight hours.

(2) The structure is damage tolerant. Adequate residual strength is available after a crack has propagated, and the basic structural configuration provides for slow crack growth and arrestment before reaching critical lengths.

(3) An inspection program has been established on the basis of a fail-safe structure with adequate external detectability, as verified by component tests. In addition, the start of inspection and sampling intervals were based on fatigue, corrosion, and crack-propagation resistance of the structure.

STRUCTURAL RELIABILITY

A distribution is shown in figure 2 to indicate the overwhelming influence of development testing and detail design on the structural reliability of the DC-10. These two items were accomplished during initial design stage; they allow true optimization of the DC-10 airframe by "placing the structural material where it is most effective" and thereby provide maximum-fatigue-life assurance. In any event, it is necessary to establish fatigue criteria, identify sensitive areas, establish fastener policies, and plan an early development testing program. Without these procedures, the structural design cannot be successful.

A new computer analysis system was used with a high degree of accuracy in predicting the actual working stress levels and deflections in the structural elements. Full-scale fatigue tests were used to reveal weak links and verify that proper analysis and detail testing were accomplished during the aircraft design.

FATIGUE-SENSITIVE AREAS

Once the fatigue-sensitive areas are recognized, proper emphasis can be given to these problem areas to assure fatigue reliability. In the design of the DC-10 aircraft, these areas, as shown in figures 3 and 4, were given special attention during design, analysis, and testing.

The fatigue reliability of the wing box and fuselage pressure shell, splices, joints, and other discontinuities has been made equal to or better than that of the basic structural items 4, 9, and 10 of figure 3.

ANALYSIS

Evolution of FORMAT

In order to assure design static and fatigue strength, actual working stresses and deflections were predicted with the use of the FORTRAN Matrix Abstraction Technique

(FORMAT) developed by Douglas Aircraft Company over a period of 20 years (ref. 1). Improved computer methods and techniques, such as FORMAT, gave increased analysis capability and visibility over the original DC-8 airframe, as shown in figure 5.

The FORMAT system is fully automatic so, even during preliminary design, structural weight is minimized and fatigue characteristics are improved by placing the material where it is most effective (ref. 2).

Deflections

Figure 6 shows the excellent correlation of deflections from FORMAT analysis with test results. The comparison shows deflections for limit-positive-load conditions for the wing, fuselage, and horizontal stabilizer. The test results were obtained from a successful static-load test completed on the second production aircraft in August 1970. The aircraft was fully instrumented with strain gages and deflection transducers by using a sophisticated 1000-channel data system.

Stress Analysis

Figure 7 shows the stresses in the complicated root section of the wing subjected to limit positive-maneuver loads (from the front spar (F.S.) to the rear spar (R.S.)) and the equally sensitive fuselage section above the wing subjected to limit down-bending loads. The circles represent static test measurements, and the solid line indicates the stresses computed by FORMAT analysis. The dashed lines indicate the stresses computed by elementary beam theory which underestimates the stresses at the sensitive structural areas. The excellent accuracy of the detail stress analysis allows the calculation of reliable local stress levels and assures the fatigue quality of the DC-10 structure.

Working Stresses

The working stress levels for the DC-10 wing have been carefully established on the basis of the working stresses used on earlier airplanes which, since, have had proven longevity (fig. 8). The working stress levels for the fuselage shell have increased mainly because of the wide-body cross section. This increase in stress has been accomplished with no loss in fatigue strength through improvement in detail design.

Fatigue Quality Structure

The increase in working stress levels and the additional requirement for dependable long-life aircraft make it mandatory to increase the fatigue quality of all structural elements. The results of several thousand constant-amplitude component fatigue tests of structural elements of various configurations are summarized in figure 9. (R is the

maximum stress in any cycle divided by the minimum stress in the cycle.) It is noteworthy that the basic structure has considerable longevity as attested by the DC-3, DC-6, DC-7, and DC-8 airframe structure. As shown, the DC-6 and DC-7 joints were critical; the DC-8 joints were practically equivalent to the basic structure, and the DC-10 joints are equal to or better than the basic structure. The DC-10 structure incorporated the best structural details gained from knowledge of DC-8 structure and DC-10 development testing.

DEVELOPMENT TESTS

The results of over 2000 fatigue development tests conducted on the DC-8 and DC-9 have been used in conjunction with an additional 1700 fatigue development DC-10 tests to substantiate crack-free, long-life structures. The fatigue development test program has been completed in time to permit the designer to incorporate the test findings into the design. The DC-10 program was planned to utilize small inexpensive specimens as well as large aircraft components.

Specimen Development Testing

Double bow-tie wing specimens have been used to obtain reliable fatigue data in minimum time and at minimum expense. Results from specimens of this type have been found to correlate closely with results from more complex and expensive specimens composed of skin and stringers. These tests permit rapid evaluation of various attachment types, hole sizes, hole-preparation methods, material-thickness effects, claddings, and so forth, on the fatigue life of the basic structure. Bow-tie wing specimens cannot be used for all configurations; therefore, more typical simple wing slices were also used to evaluate fasteners. Over 300 specimens of these types were tested. The test results are shown in figure 10.

The simple longitudinal and transverse skin splices and the longeron-to-frame-connection fuselage fatigue development tests were separately conducted to evaluate and screen materials, fastener selection, surface treatment, and so forth. The results of the longitudinal and transverse tests are shown in figure 10.

Component Development Testing

Structural-wing-component fatigue development tests were conducted on actual parts that are used in the final aircraft design. All the knowledge gained through the bow-tie and other specimen testing was incorporated in the structural components. Approximately 140 tests were conducted. These aircraft components (fig. 3) were tested and improved until at least 150 000 to 350 000 flight hours were attained. The results are shown in

figure 11 for constant-amplitude tests. After the final configurations were selected, flight-by-flight spectrum tests were conducted on major components to verify the minimum of 150 000 flight hours.

Six curved stiffened 168- by 104-inch panels, representing various areas of the fuselage, were tested under combined biaxial loads, pressure, and inertia loads. The design features gained on the previously described specimen development tests were incorporated into the design of these panels. The panels consisted of eight frames, 11 longerons, four-way splice (longitudinal and transverse) basic structure, and longeron-to-frame connections. Fatigue tests were performed on the curved panels. Both pressure and axial loads were cycled at constant load levels to simulate stresses higher than those which would produce fatigue damage equivalent to the full spectrum of loads experienced by the aircraft in flight (fig. 11). Additional fatigue tests were conducted on window-belt panels and pressure-bulkhead panels.

These specimens were tested in 1.5-million-pound fatigue test machines at the laboratory test facility. Four of these machines could each hold and test two specimens simultaneously. In this way, the tests were finished quickly so that the findings could be incorporated into the drawings early in the design.

DETAIL DESIGN

The basic design considerations for fatigue-resistant structure have been established for the DC-10 by paying strict attention to proven detail design concepts. Before fabrication, wooden models of all important structural fittings were made to review for notch concentrations and unexpected machine mismatch areas. Photo stress tests were also conducted on main fittings to determine the stress distributions and peak stress magnitudes in areas where stresses are difficult to predict. On the basis of DC-8 and DC-9 experience, coupled with the extensive DC-10 development test program, many fatigue design features were established, as shown in figures 12, 13, and 14.

The fatigue life of the DC-10 inboard sweep break skin-stringer joint (fig. 12) became greater than that of the adjoining basic structure after the components were properly tapered and material was added locally at the discontinuities. Interference-fit attachments were also used to increase fatigue life.

To attain maximum fatigue-resistant structure of basic leading-edge skin to spar-cap structure, a sacrificial doubler has been used to attach the interchangeable leading-edge section to the front-spar (F.S.) cap as shown in figure 13. This design allows the use of interference attachments in the heavier spar-cap flanges.

Figure 14 shows the fuselage detail design features. The use of properly stepped doublers around the fuselage door corners reduces stress concentrations. Adding a local

channel pad to the longeron reduces local bending between the longeron and frame connection. The scalloped longeron splice fitting and fingered doublers assure uniform load transfer and reduce the first attachment load.

QUALIFICATION TESTING

The DC-10 is undergoing a flight-by-flight production-airplane fatigue test to 120 000 flight hours and 84 000 flights. The fourth production airplane is divided into three major sections, as shown in figure 15. The shaded test structures shown at the ends of each section represent steel drums that are a minimum of one fuselage diameter in length to assure that load is properly introduced into the aircraft structure. Special design aluminum transition sections modulate interaction effects between the steel drums and aircraft structure to preclude fatigue failures in that region. The division into three sections was based on the following factors:

- (1) There are fewer compromises in the load spectrum.
- (2) Noncritical loads can be eliminated and other critical loads added for each undivided section.
- (3) Sections can continue cycling while one section is down for inspection or repair.

The cycles are being applied to each individual section as shown in the following table:

Type of load	Number of cycles applied to -		
	Forward section	Wing-fuselage section	Aft section
Ground loads	252 000	389 840	168 000
Flight loads	383 040	913 332	753 648
Landing impact	37 800	36 540	37 800
Ground-Air-Ground (G-A-G)*	84 000	84 000	84 000
Fuselage pressurizations	84 000	84 000	84 000
Total:	840 840	1 507 712	1 127 448

* Inherently obtained because the load spectrum is applied on a flight-by-flight basis.

Testing experience has shown that proper loads can be applied more accurately to smaller components subjected to large concentrated loads. The main and nose landing gears and adjacent support structure, therefore, are tested separately so that every detailed area is subjected to the millions of cycles that occur in service (ref. 3).

DAMAGE-TOLERANT STRUCTURE

The DC-10 primary structure is designed to be fail-safe, with the exception of the landing gear for which fail-safe design is not practical. The fail-safe criterion used in the DC-10 is more stringent than specification requirements; that is, the structure must support the fail-safe load soon after several components have failed.

Identification of Sensitive Areas (Fuselage)

The radial loading due to cabin internal pressure can start a longitudinal skin crack in two locations:

- (1) At the skin line where the fingered doubler is attached to the skin of the longitudinal skin splice, shown in figure 16(a) (This type of fatigue crack results in a one-bay longitudinal skin crack.)
- (2) At the first attachment of shear clip frame to skin, shown in figure 16(b) (The fatigue crack of this type can propagate into a two-bay longitudinal crack.)

The combined pressure and axial loads can start a transverse skin crack where the longeron is attached to the frame. After failure of the longeron a skin crack can form which may propagate into two adjacent skin bays, shown in figure 16(c). Recognition of these facts led to the following damage-tolerant conditions selected for the fuselage shell structure shown in figure 16(d):

- (1) Two-bay longitudinal crack with center crack stoppers failed
- (2) Two-bay transverse crack with center longeron failed

The design selected contains titanium crack stoppers at each frame capable of arresting a two-bay longitudinal crack. The hat section longerons act as natural transverse crack stoppers.

Stress Analysis (Fuselage Panels)

The equation for the fracture strength of stiffened thin panels containing a crack is

$$\sigma_R = \frac{K_c R_{ct}}{\sqrt{W \tan\left(\frac{\pi a}{W}\right)}}$$

where

σ_R gross residual stress, psi

K_c plane stress fracture toughness, psi $\sqrt{\text{in.}}$

$$R_{ct} = \frac{\text{Crack-tip stress of unstiffened panel}}{\text{Crack-tip stress of stiffened panel}}$$

W panel width, inches

a half crack length, inches

σ_s stiffener stress, psi

σ gross applied stress, psi

Toughness K_C is determined from tests on stiffened panels as shown in figure 17(a). The ratio R_{ct} is determined from analysis of unstiffened and stiffened panels having the same grid size by taking a ratio between the crack-tip stresses (ref. 4). The idealized structure and analysis are based on the FORTRAN Matrix Abstraction Technique (FORMAT) shown in figure 17(b).

Skin Fracture Criterion (Fuselage Panels)

Results of fuselage panel residual strength tests are shown that verify test and theory correlation. The shape of the curve is determined by analysis and the height by critical fracture toughness K_C . (Note the point of fast fracture.) The curve plotted in figure 17(c) shows correlation with the analysis at critical crack length, crack arrest, and final failure.

The maximum allowable principal stress for a two-bay longitudinal crack is above the maximum operating principal stress for the DC-10 and provides an adequate margin of safety.

Stiffener Criteria (Fuselage Panels)

Stiffener strength must be adequate. In order to maintain the skin fracture strength, the stiffener must not fail. An example of frame (aluminum) stress and outer-crack-stopper (titanium) stress correlation is shown in figure 17(d).

Fail-Safe Testing (Fuselage Panels)

Extensive fail-safe testing has been completed. A comprehensive test program was initiated early in the DC-10 design to verify analytical methods and to evaluate various stiffener configurations and materials. Figure 18 illustrates some of the fail-safe development test specimens. Finally, six 118.5-inch-radius curved panels were tested to determine the residual strength. These tests showed that the fuselage shell structure

provides more than adequate fail-safe capability for the conservative two-bay selected damage-tolerance criteria.

Stress Analysis and Testing (Wing Panels)

An important design consideration of the DC-10 wing structure is to sustain an initial failure of a member but allow for extension of the failure over a reasonable number of additional flight hours. This approach assures that an initial crack will not grow to critical proportion before it is detected during routine inspection intervals.

The damage-tolerance criterion, a two-bay crack with center stringer failed, has been incorporated into the design of the DC-10 wing box structure shown in figure 19. In addition, four separate skin panels are used on the wing lower surface to arrest further any crack propagation.

Figure 20 shows FORMAT analysis correlation with experimental results obtained from tests of large skin-stringer panels representing typical wing box construction. Stresses at adjacent stringers have been calculated as functions of crack length. The results have been verified by strain-gage test results.

STRUCTURAL INSPECTION AND MAINTENANCE PROGRAM

The purpose of the structural inspection and maintenance program is to detect structural problems on aircraft before airworthiness is affected or expensive repairs become necessary. The importance of the structural inspection and maintenance program was recognized during initial DC-10 design stages. Goals were established to provide required structural airworthiness levels at minimum inspection and maintenance costs.

The main approach is to give full assurance that the aircraft structure will be relatively crack free for its intended service life of 60 000 flight hours and 42 000 flights. This high degree of structural reliability was achieved by designing, analyzing, and testing to (1) a fatigue life in excess of 120 000 flight hours and 84 000 flights to crack initiation and (2) a fail-safe life based on a two-bay crack length requirement.

Fatigue Life

Item (1) – that is, a fatigue life in excess of 120 000 flight hours and 84 000 flights to crack initiation – incorporates various design features.

Working stress levels. - Accurate stress levels were predicted for structural sizing using FORMAT analysis. Stress levels are equivalent to those of the DC-8 and DC-9, which have excellent service experience.

Detail design. - Stress concentrations were minimized in joints, splices, and basic structure by the use of proper tapering and scalloping, stress coining, and interference-fit attachments (ref. 5). Preload stresses were minimized by providing flexible structure in design, shop fabrication assembly, and installation tolerance control. Detail design quality of the structure is equivalent to, or better than, DC-8 and DC-9 quality, as verified through component fatigue test results.

Corrosion and stress corrosion. - Corrosion was prevented through faying-surface sealing, priming, top coating epoxy paints, draining, using clad aluminum materials, and using high-strength fasteners installed wet with sealant or primer. Stress corrosion resistance was maximized by utilizing 7075-T73 material, which has a high corrosion threshold.

Fail-Safe Life

Item (2) - a fail-safe life based on a two-bay crack length requirement - involves two main design considerations. The use of FORMAT analysis, verified by large panel component tests, enabled the structure to be designed for slow crack growth and crack arrestment.

Crack growth. - Slow crack growth is attained through the selection of 2024 aluminum with its high fracture toughness properties (low notch sensitivity) and by the use of low working stress levels (ref. 6).

Crack arrestment. - Cracks are arrested by the use of titanium straps at fuselage frames, additional spanwise splices, separately attached but closely spaced wing stringers, and stiffeners attached to the fuselage shell and bulkheads.

Significant Structural Items

Because of the high probability of a long fatigue life, the inspection program will be started rather late in the service life. Also, because the structure is fail-safe, the inspections can be spaced somewhat farther apart than those on older types of aircraft (ref. 7).

The selection of the significant structural items to be inspected is based on the knowledge and experience with past programs and the manufacturer's assessment of the most fatigue- and corrosion-sensitive structure. It is necessary, therefore, to define the following two steps:

(1) External structural members are designed to crack before complex or hidden joints, doublers, frames, and so forth. This "controlled failure" approach was developed and confirmed by many component tests. For example, over 300 fuselage skin splice specimens were tested to assure skin external crack failures (fig. 21).

(2) Internal members, if cracked, are designed to eventually propagate the crack through to the external members so that the crack becomes externally detectable. The slow crack growth provides sufficient time to inspect and detect cracks before failure, and crack arrestment and the two-bay-crack residual strength of the design provide adequate fail-safe strength.

Initial Inspection and Intervals

The inspection plan has been designed to detect crack initiation, early signs of corrosion, and manufacturing variabilities (preload). The statistical approach was used to obtain a feel for the effect of fatigue variability (ref. 8) and fracture roughness characteristics. The variabilities required the use of knowledge gained from the DC-8 and DC-9 successful service experience.

The plan of inspection for structural fatigue critical items is listed below:

- (1) External items receive 100-percent inspection at periodic intervals.
- (2) Internal items, with external detectability, receive 100-percent inspection externally at periodic intervals.
- (3) Major load-carrying internal items, without external detectability, are inspected as frequently as the external items.
- (4) Other load-carrying internal items, without external detectability, receive only sampling inspection.

The inspection and maintenance program for the DC-10 is designed to assure maximum vehicle airworthiness at minimum cost.

CONCLUSIONS

To date, both the DC-8 and DC-9 fleets have been flown with only a few isolated fatigue failures in the primary structure; this fact is significant because high-time DC-8's have accumulated about 48 000 flight hours and 28 000 landings, and DC-9's have recorded 32 000 landings.

The DC-10 is a third-generation jetliner and, therefore, is expected to be superior to its predecessors because of the following factors:

- (1) Crack-free life of 60 000 flight hours
- (2) Slow crack growth and arrestment
- (3) External detectability in main load-carrying structure
- (4) Completed development testing during initial design

- (5) Detail design and fatigue procedures based on past experience
- (6) Working stress levels and deflections based on accurate design
- (7) Fatigue critical areas recognized in planning stage
- (8) Full-scale tests reveal weak links and check performance.

REFERENCES

1. Picard, J.; and Morris, R. C.: *FORMAT II – Second Version of Fortran Matrix Abstraction Technique*. AFFDL-TR-66-207, Vols. I and III.
2. Warren, D. S.: *Applications Experience With the FORMAT Computer Program*. Douglas Paper 5095, presented to the Second Air Force Conference on Matrix Methods, Wright-Patterson Air Force Base, Ohio, Oct. 15-17, 1968.
3. Stone, M.: *Fatigue and Fail-Safe Design of a New Jet Transport Airplane*. Douglas Paper 3342, presented to the International Committee on Aeronautical Fatigue (ICAF) Symposium, Munich, Germany, June 16-18, 1965.
4. Swift, T.; and Wang, D. Y.: *Damage Tolerant Design-Analysis Methods and Test Verification of Fuselage Structure*. Presented to the Air Force Conference on Fatigue and Fracture of Aircraft Structures and Materials, Miami, Florida, Dec. 15-18, 1969.
5. Speakman, E. R.: *Fatigue Life Improvement Through Stress Coining Methods*. Douglas Paper 5516, presented at AIAA Meeting in Los Angeles, California, July 14-16, 1969.
6. Schijve, J.: *National Aerospace Laboratory NLR, Amsterdam, Fatigue of Aircraft Structures*, presented at the Twelfth Israel Annual Conference on Aviation and Aeronautics, Mar. 1970.
7. Eggwertz, S.; and Lindsjo, G.: *Study of Inspection Intervals for Fail-Safe Structures*. Report 120, Aeronautical Research Institute of Sweden, Stockholm, 1970.
8. Abelkis, P. R.: *Fatigue Life Scatter Factors for Design and Analysis of Aircraft Structures*. Douglas Paper 4807, 1968.

STRUCTURAL DESIGN

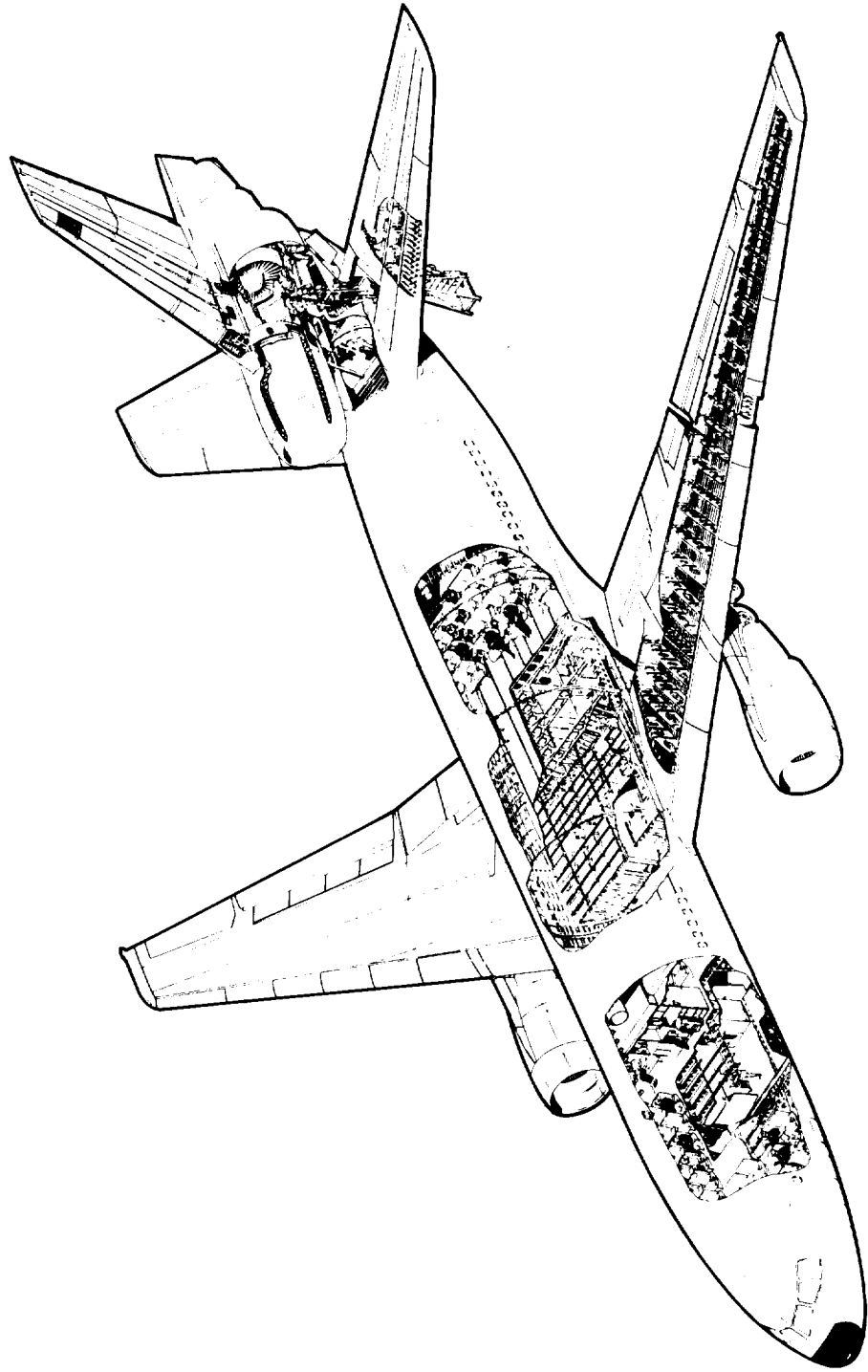

Figure 1

STRUCTURAL RELIABILITY

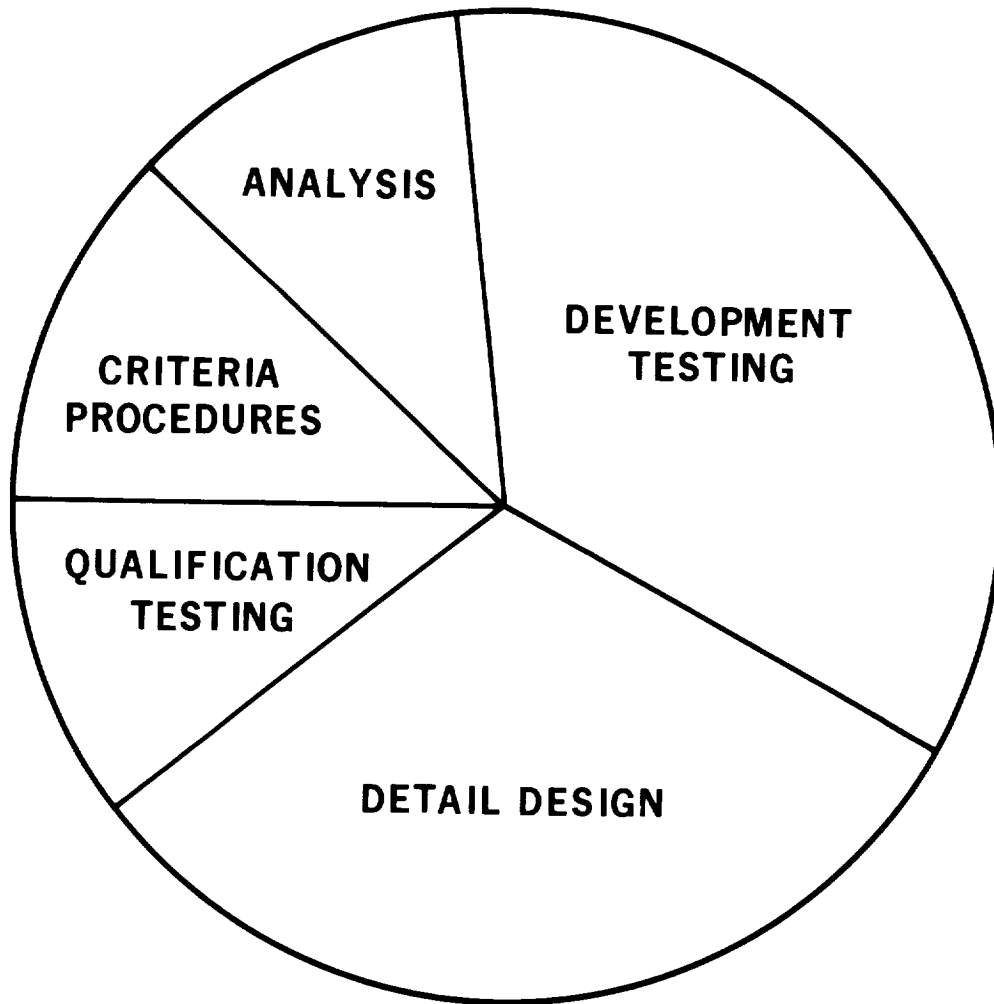
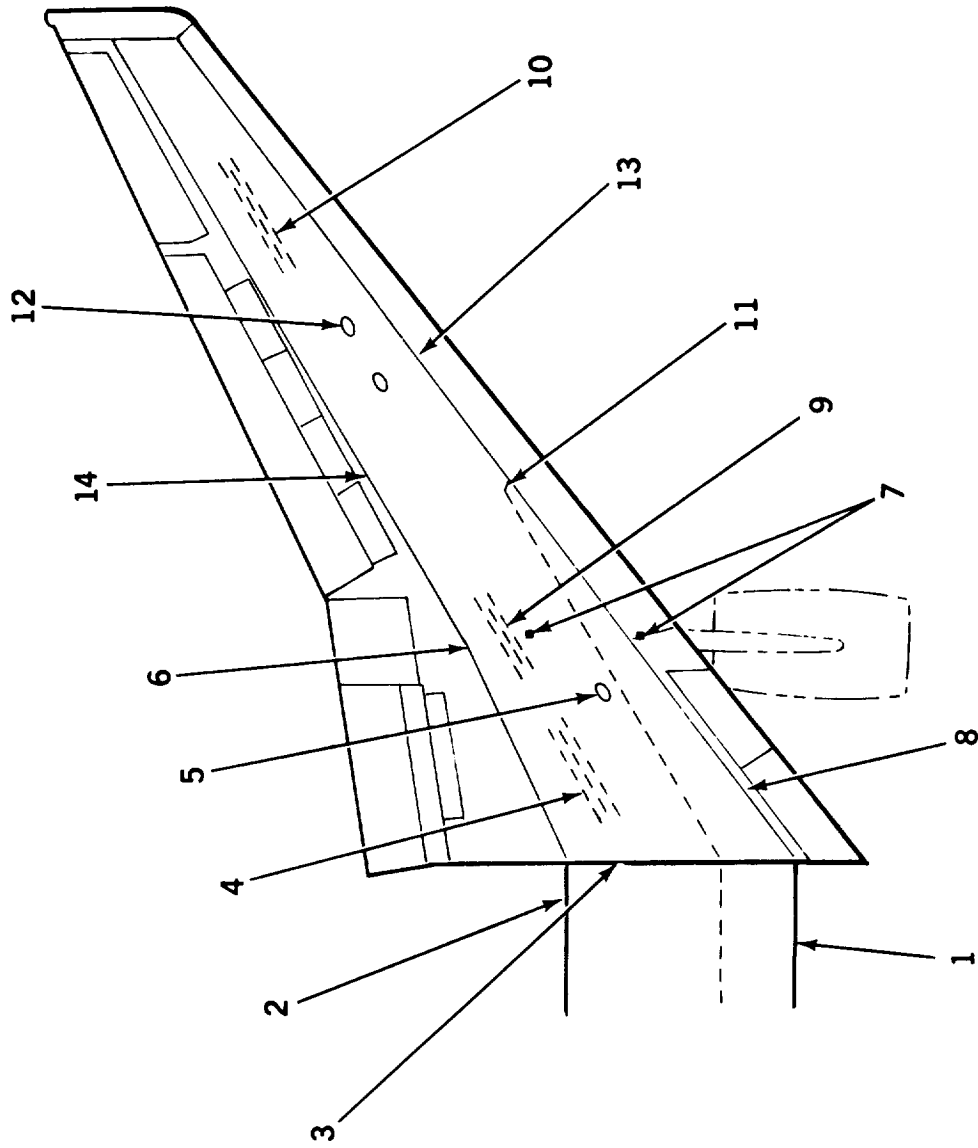

Figure 2

WING FATIGUE-SENSITIVE AREAS



- 1 — FRONT SPAR SPLICE
- 2 — REAR SPAR SPLICE
- 3 — SWEEP BREAK JOINT
- 4 — INBOARD BASIC STRUCTURE
- 5 — FUEL PUMP ACCESS HOLE
- 6 — REAR SPAR SPLICE
- 7 — PYLON ATTACHMENTS
- 8 — FRONT SPAR CAP SPLICE
- 9 — AERO BREAK BASIC STRUCTURE
- 10 — OUTBOARD BASIC STRUCTURE
- 11 — STRINGER RUNOUT
- 12 — ACCESS DOOR PANEL
- 13 — FRONT SPAR BASIC STRUCTURE
- 14 — REAR SPAR BASIC STRUCTURE

Figure 3

FUSELAGE FATIGUE-SENSITIVE AREAS

- 1 – PRESSURE BULKHEADS
- 2 – EXIT DOOR AND JAMB STRUCTURE
- 3 – WINDOW BELT PANELS
- 4 – CARGO DOOR HINGES AND LATCHES
- 5 – LONGITUDINAL SPLICES
- 6 – FOUR WAY SPLICES
- 7 – LONGERON TO FRAME CONNECTIONS
- 8 – TRANSVERSE SPLICES
- 9 – WING TO FUSELAGE TITANIUM TEE
- 10 – WINDSHIELD POSTS

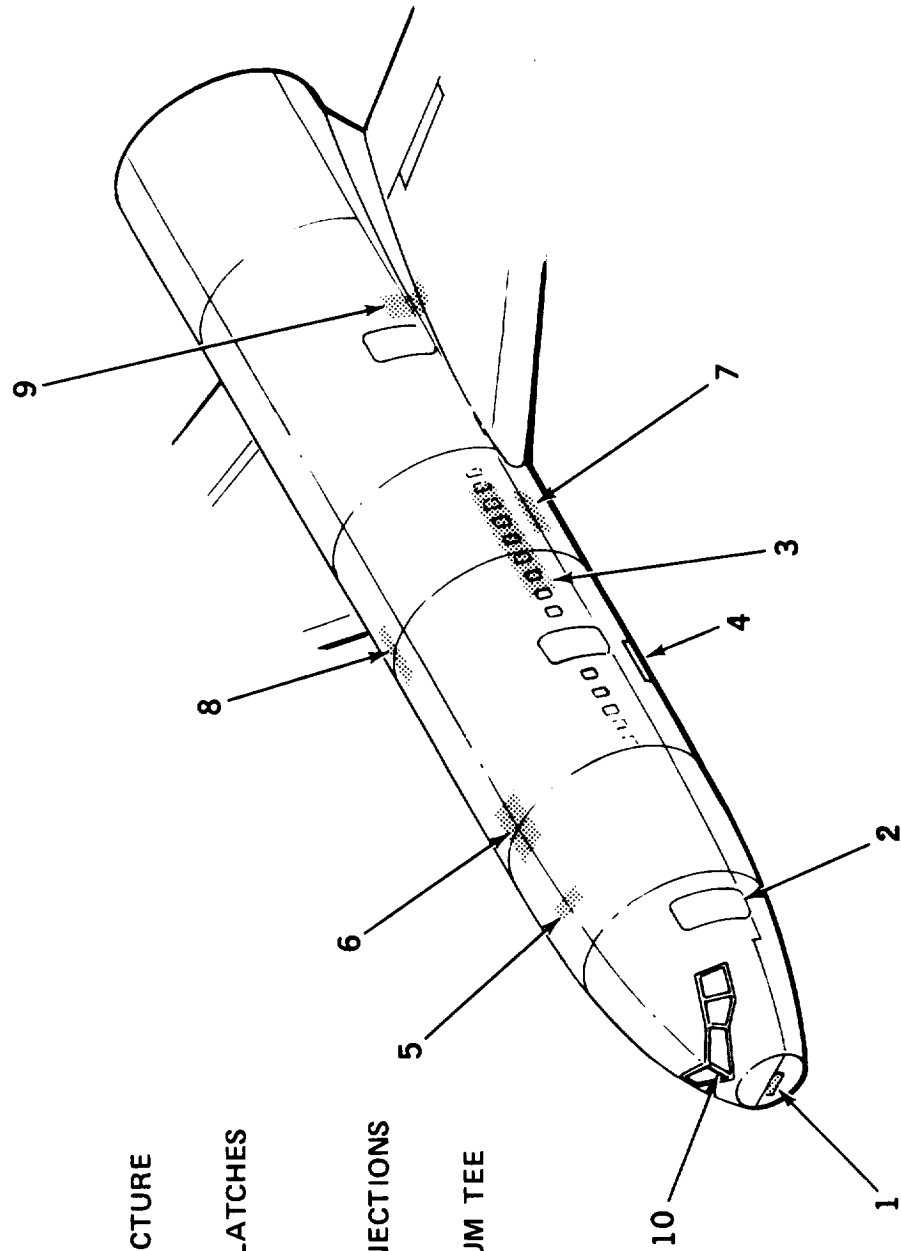

Figure 4

EVOLUTION OF FORMAT

	<u>ADVANCE DESIGN ANALYSIS</u>	<u>DESIGN ANALYSIS</u>	<u>SUBSTANTIATION ANALYSIS</u>
DC-8 (MAXWELL MOHR METHOD)	—	—	20% OF AIRPLANE (2000 FORCES)
DC-8-60 SERIES AND DC-9 (REDUNDANT FORCE METHOD)	—	10% OF AIRPLANE (2000 FORCES)	50% OF AIRPLANE (20 000 FORCES)
DC-10 (FORMAT)	10% OF AIRPLANE (6000 FORCES)	70% OF AIRPLANE (60 000 FORCES)	90% OF AIRPLANE (100 000 FORCES)

Figure 5

DEFLECTIONS

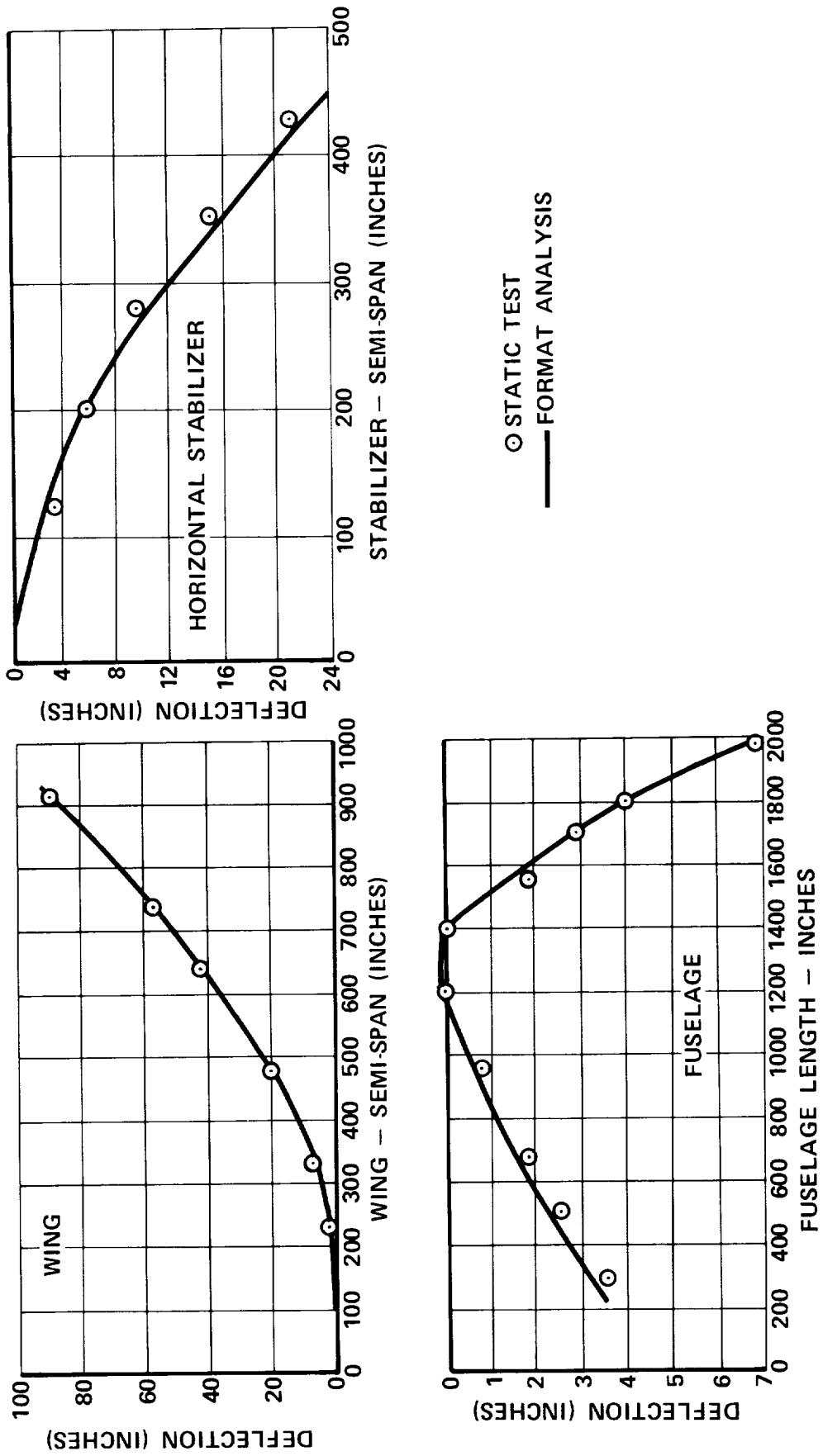

Figure 6

STRESS ANALYSIS

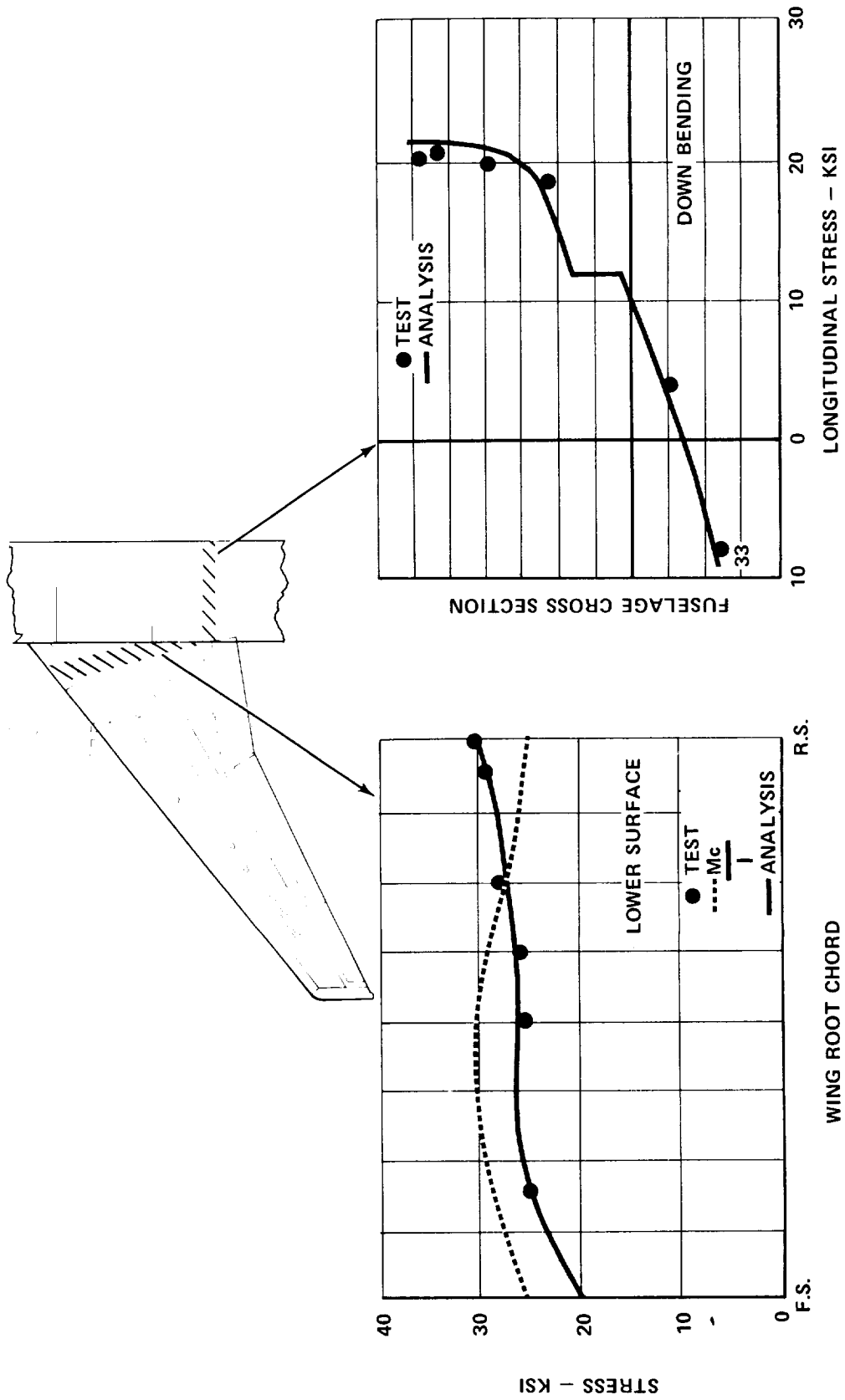

Figure 7

WORKING STRESSES

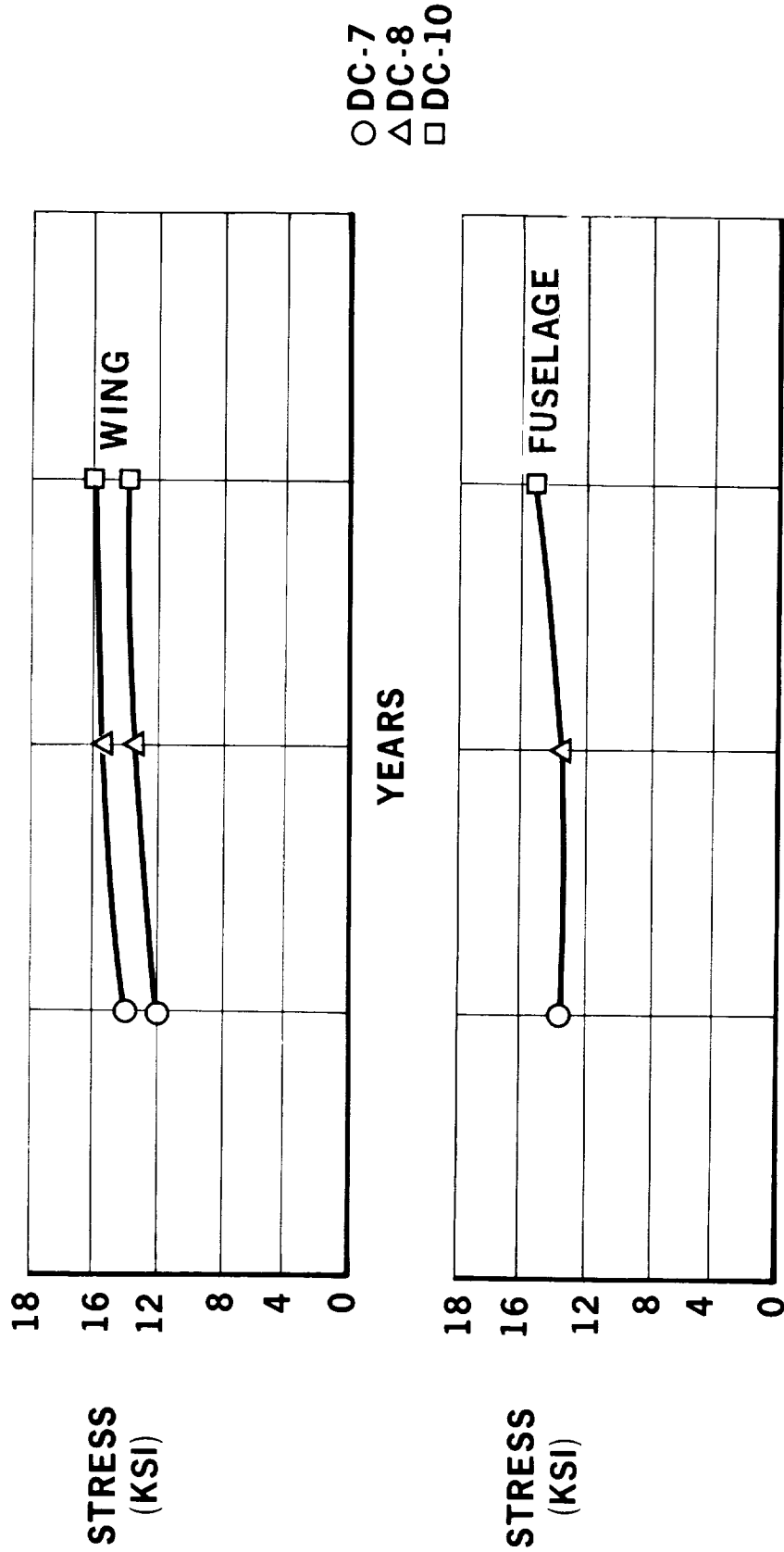

Figure 8

FATIGUE QUALITY STRUCTURE

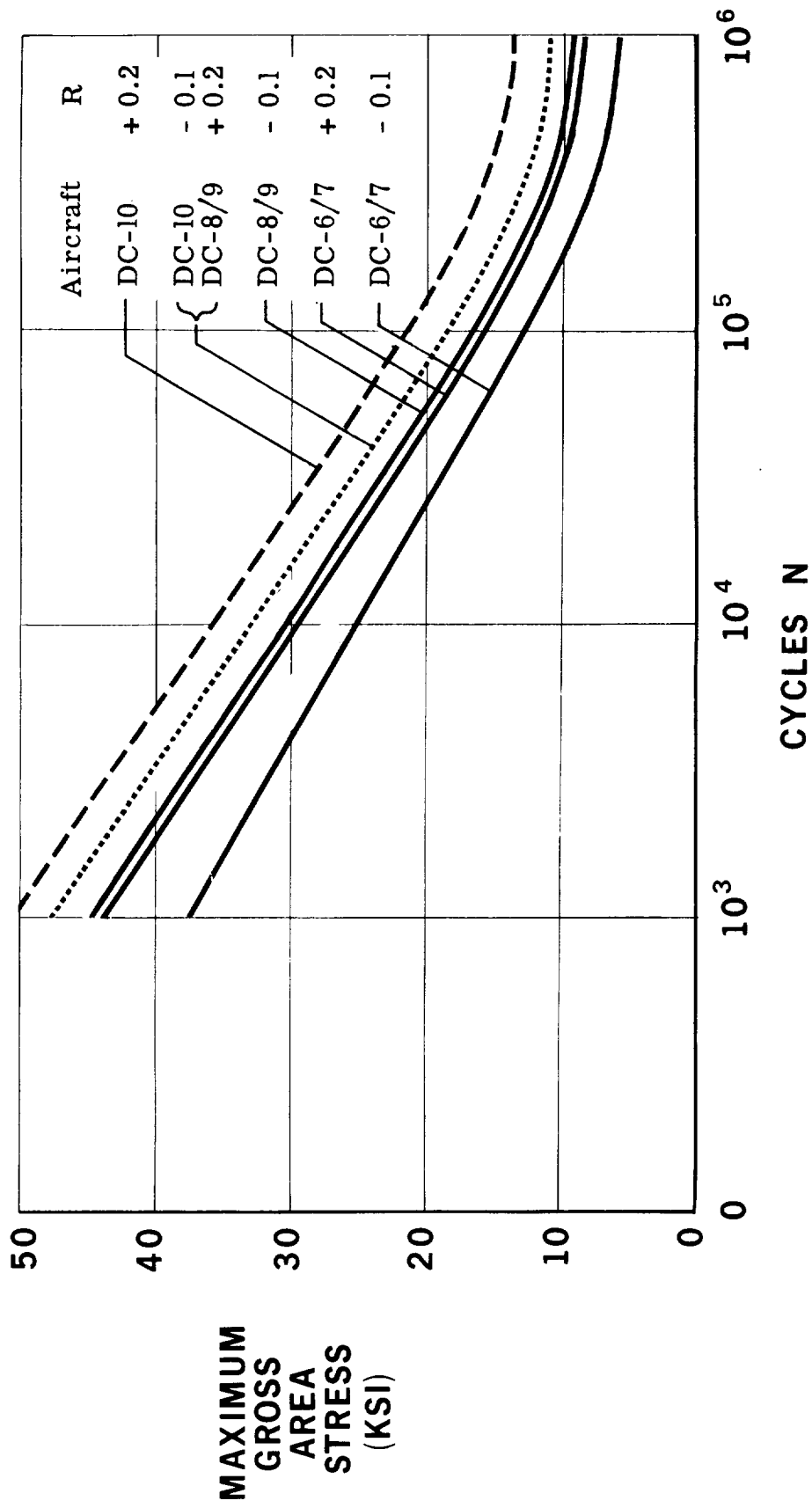

Figure 9

SPECIMEN DEVELOPMENT TESTING

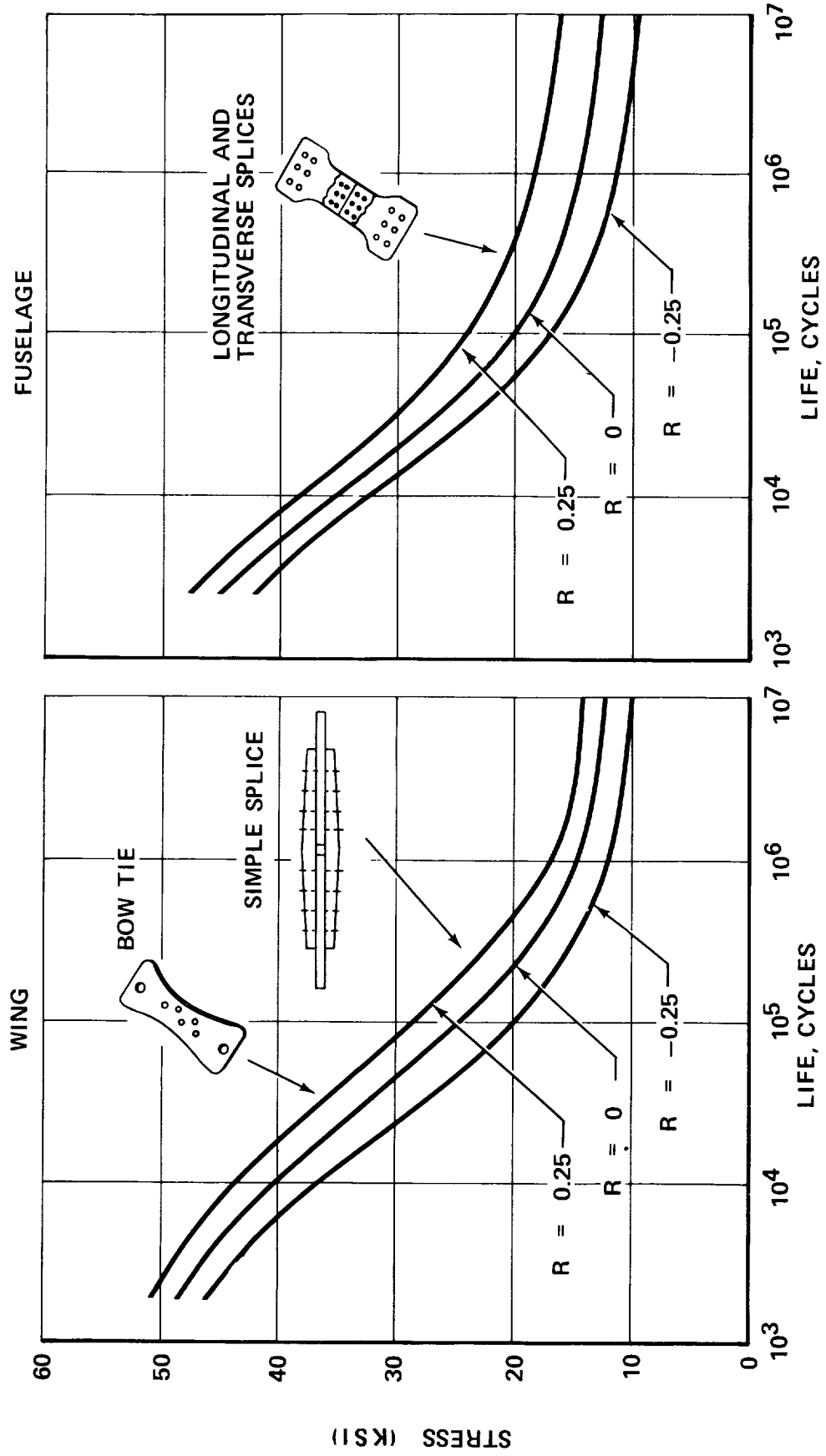

Figure 10

COMPONENT DEVELOPMENT TESTS

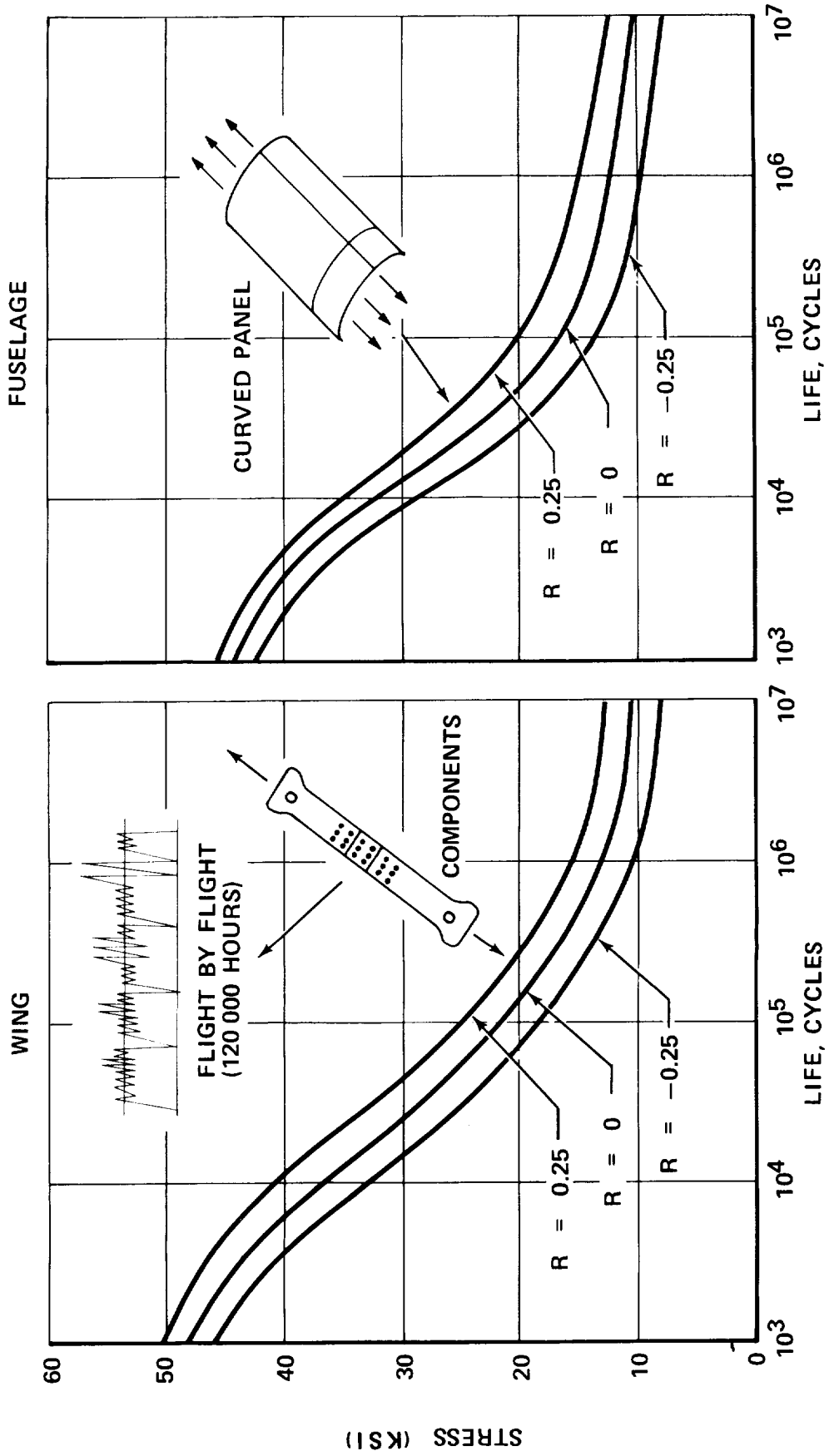

Figure 11

WING DETAIL DESIGN

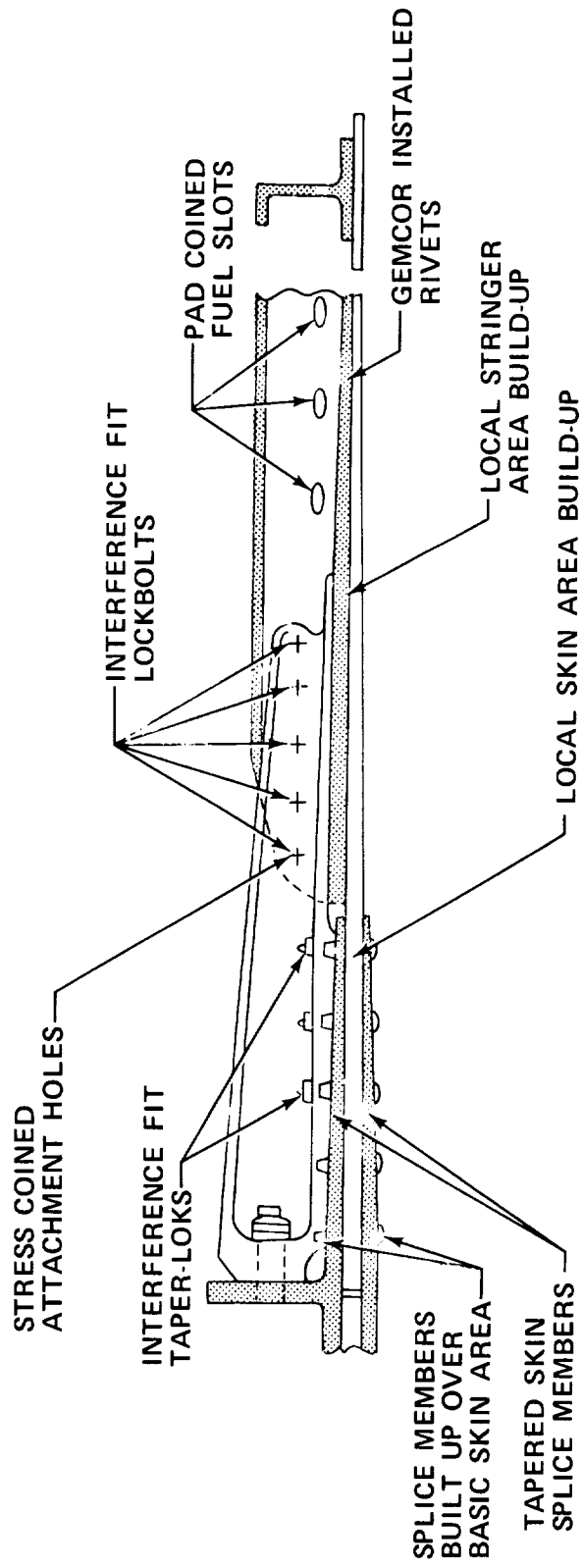

Figure 12

SACRIFICIAL DOUBLER

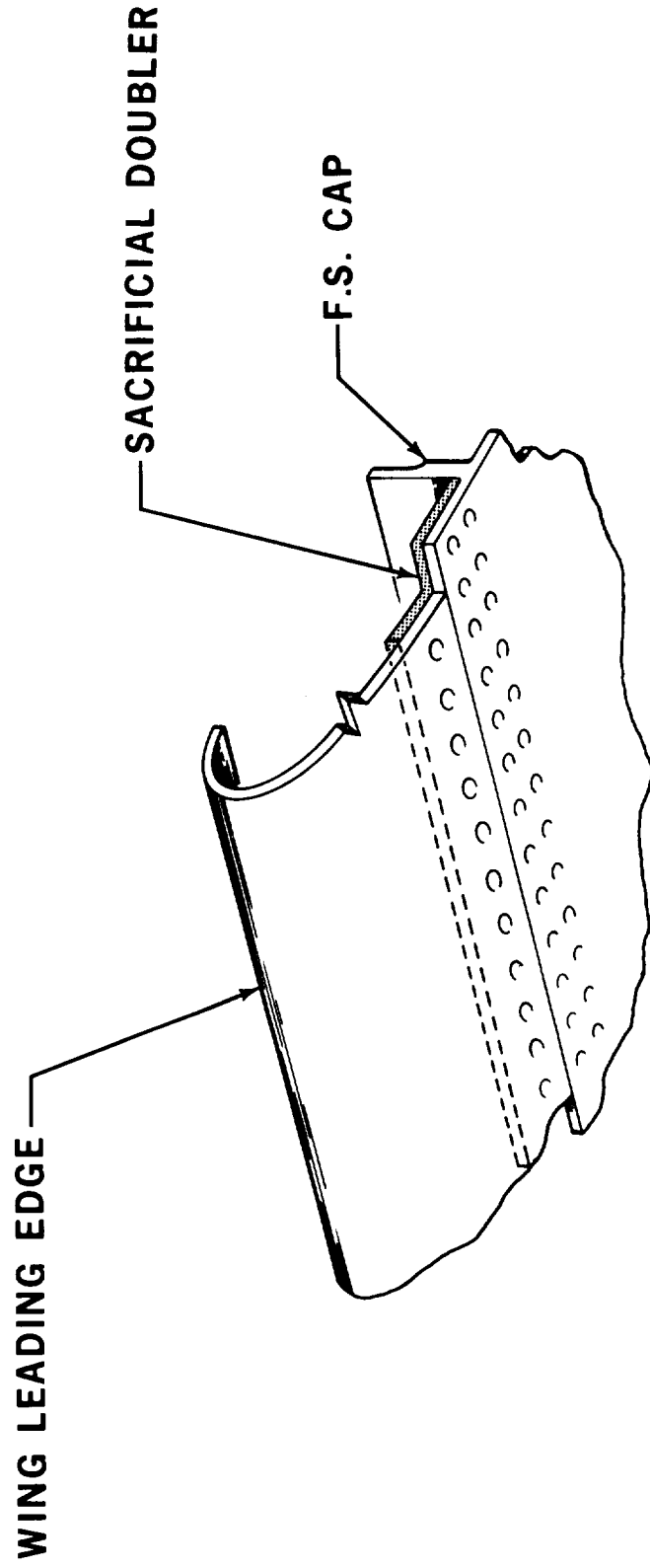

Figure 13

FUSELAGE DETAIL DESIGN

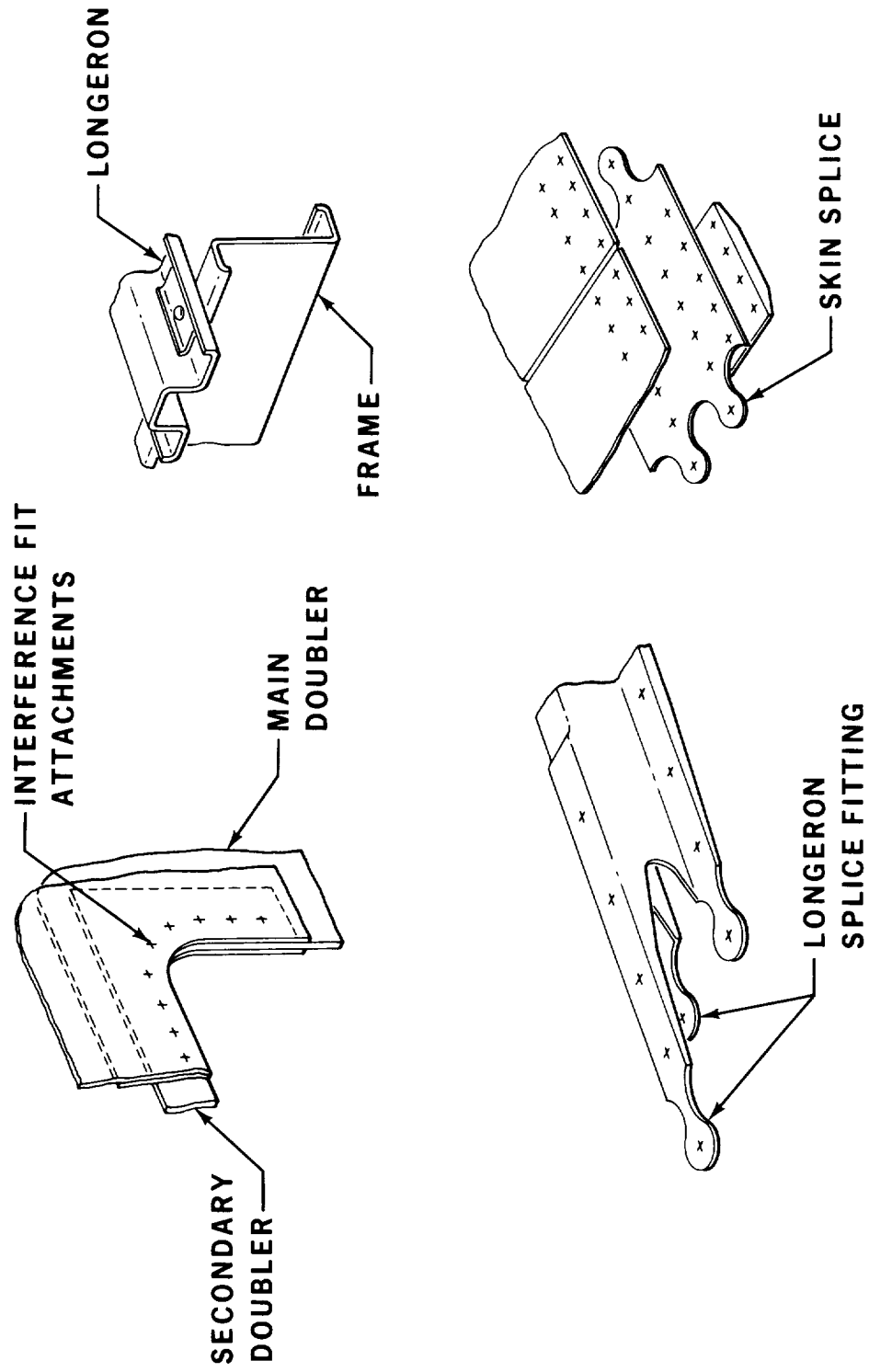

Figure 14

MAJOR FATIGUE TESTS

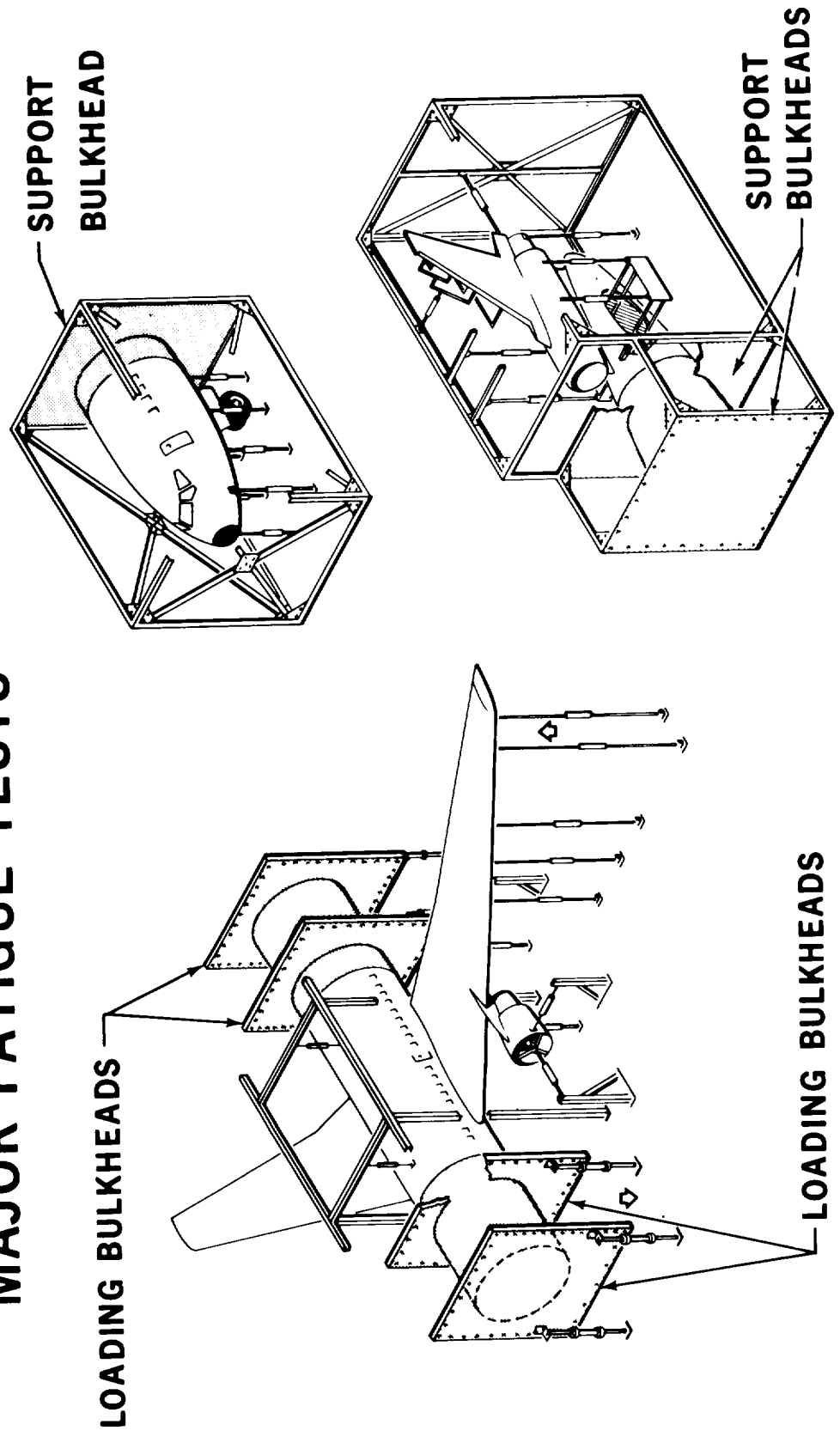

Figure 15

FUSELAGE BASIC SHELL

IDENTIFICATION OF SENSITIVE AREAS

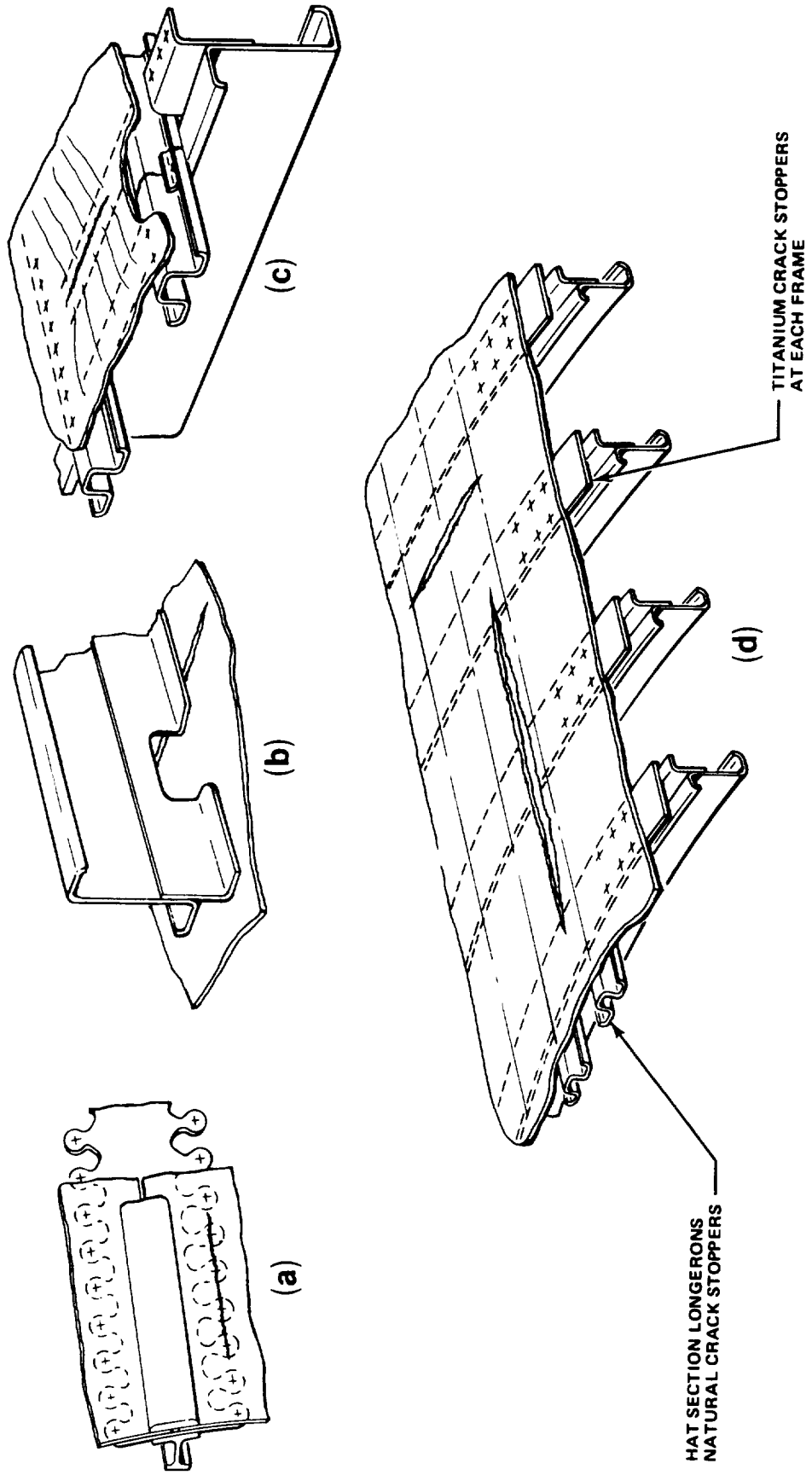

Figure 16

STRESS ANALYSIS

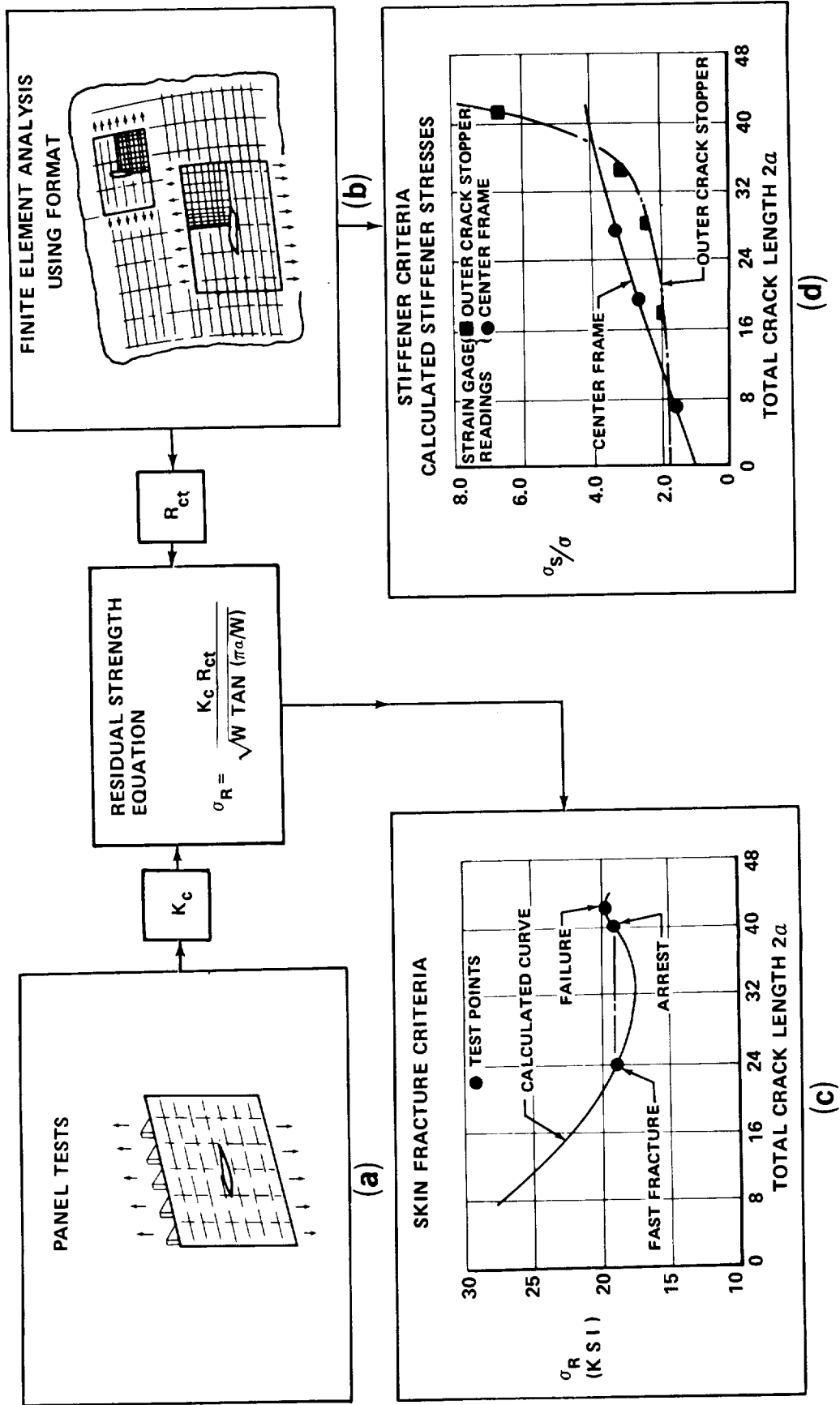

Figure 17

FAIL-SAFE DEVELOPMENT TESTS

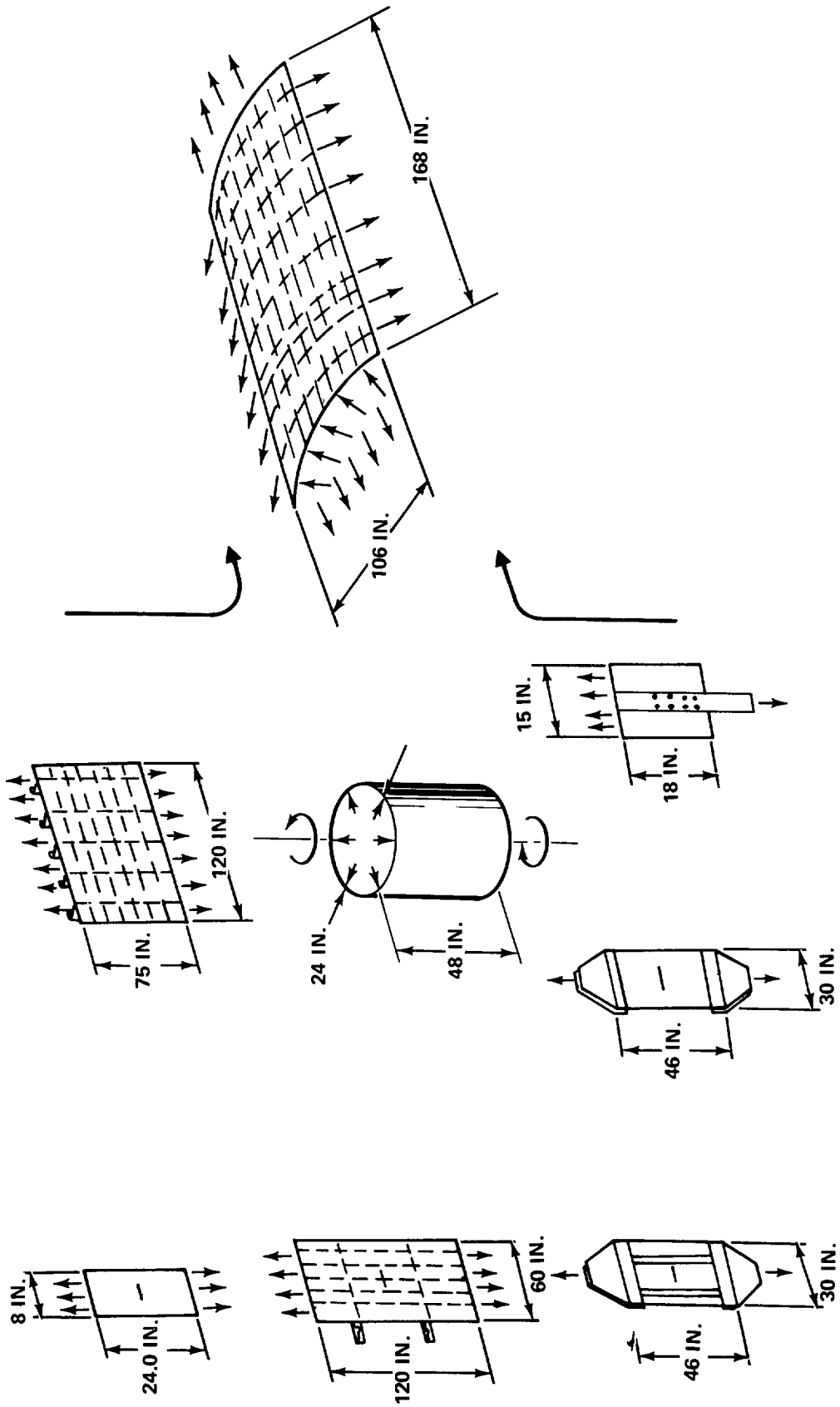
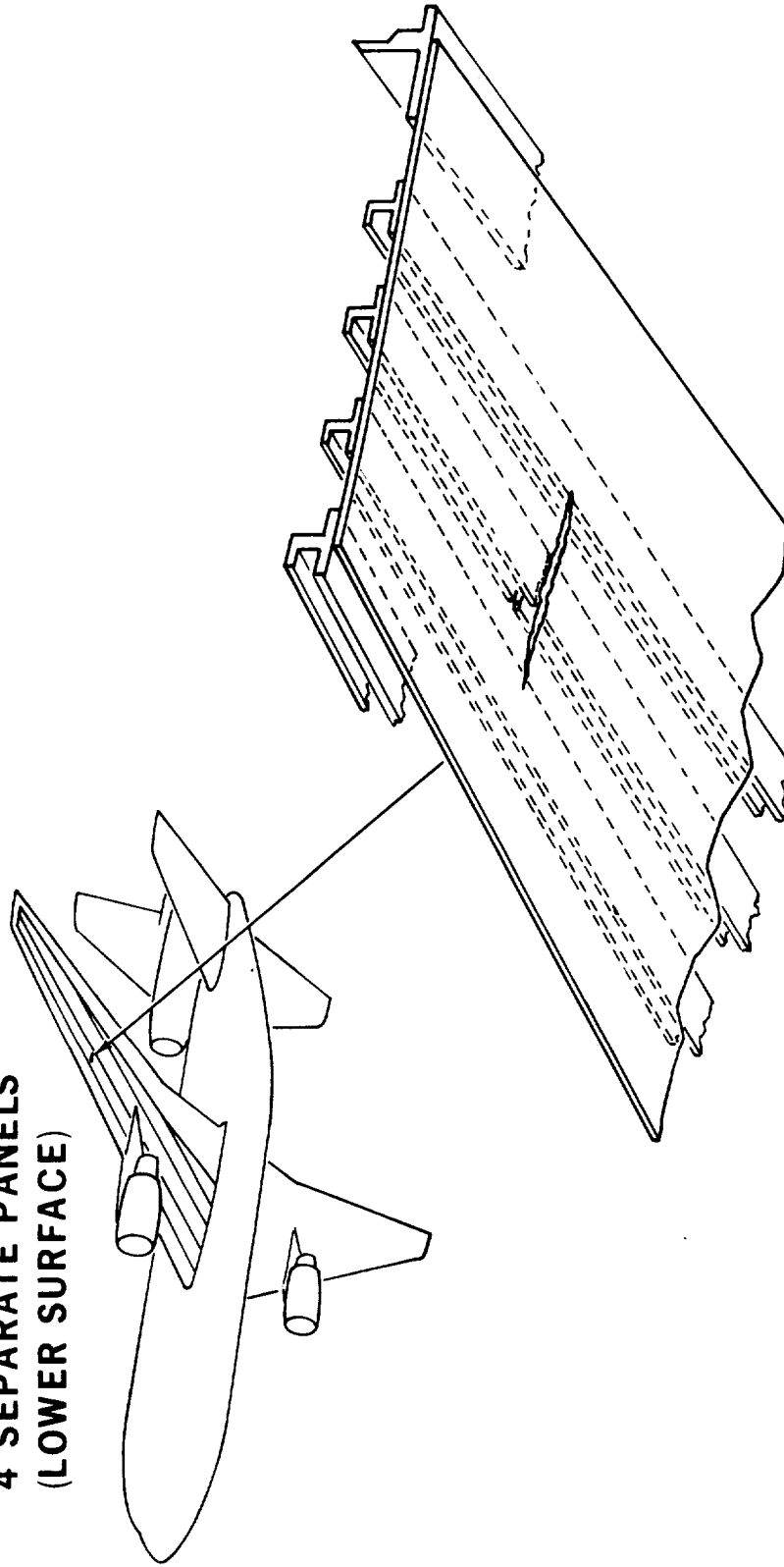

Figure 18

WING BASIC PANELS

IDENTIFICATION OF SENSITIVE AREAS

4 SEPARATE PANELS
(LOWER SURFACE)



ARRESTMENT OF CRACK AT STRINGERS

Figure 19

FULL-SCALE COMPONENT TESTS VERIFY DAMAGE-TOLERANCE CRITERIA AND ANALYSIS

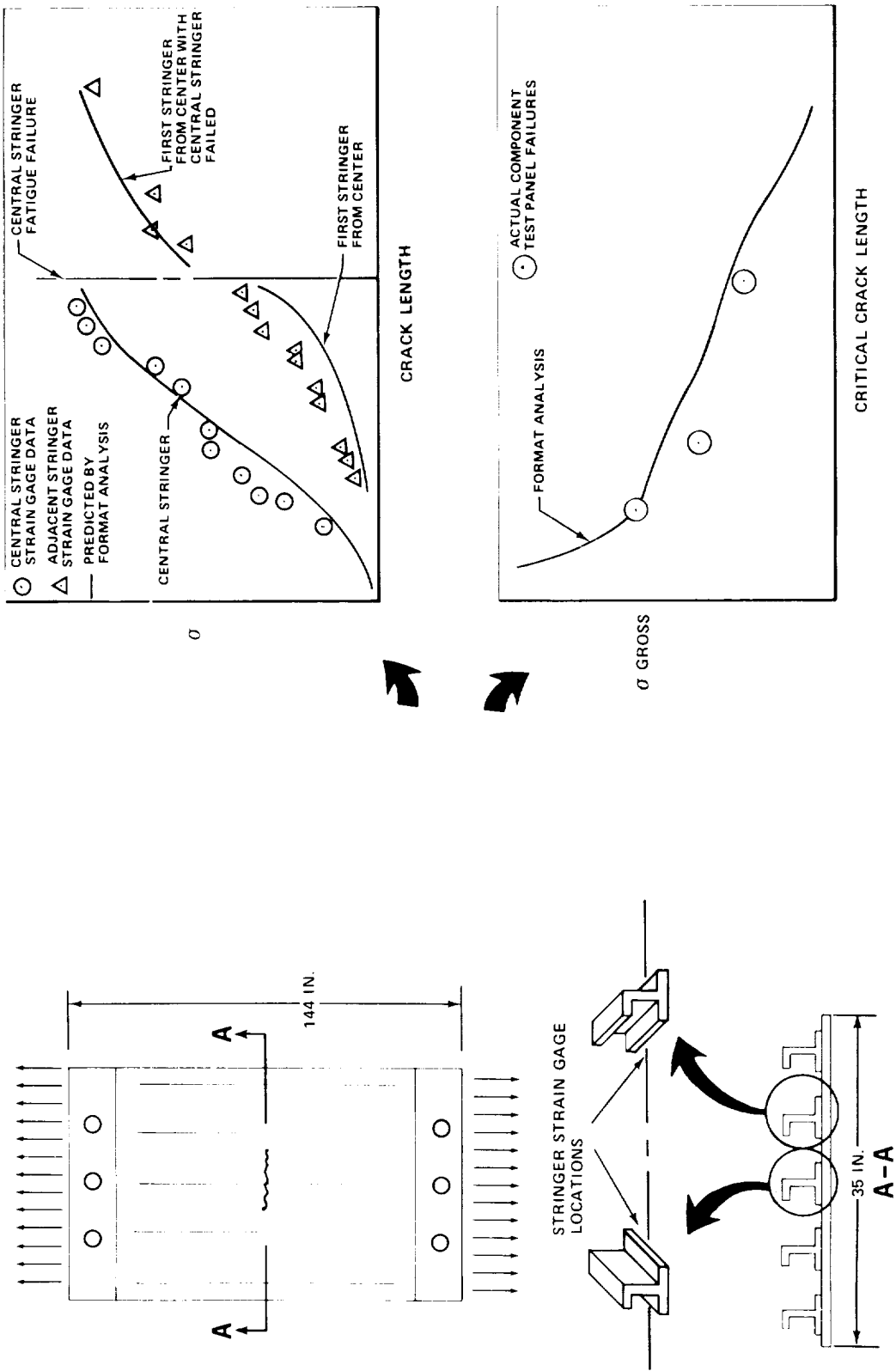
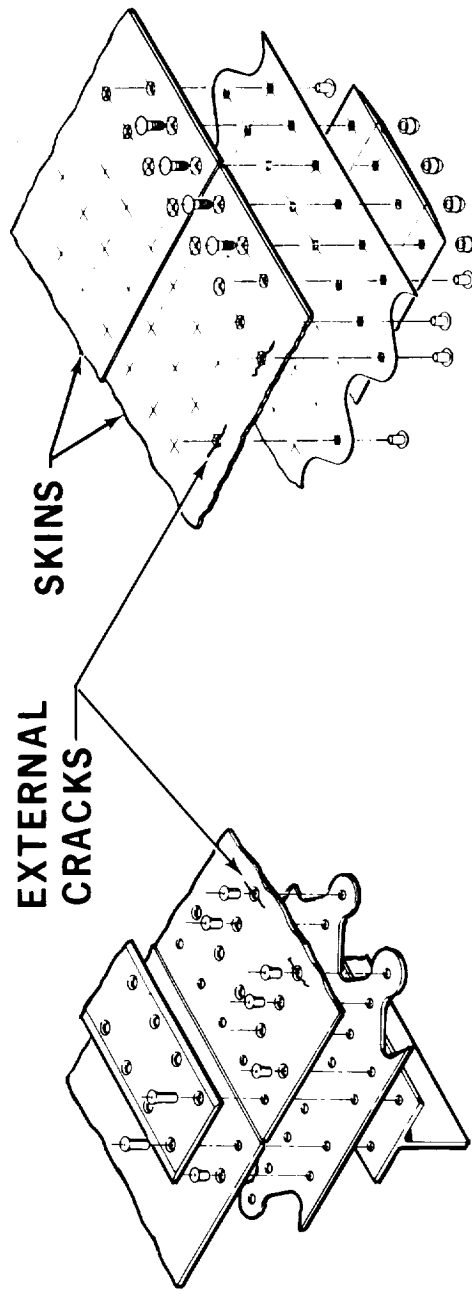

Figure 20

FUSELAGE SKIN-CRACK DETECTABILITY



**TYPICAL
LONGITUDINAL SPLICE**

**TYPICAL
TRANSVERSE SPLICE**

Figure 21

