

A DATA ACQUISITION SYSTEM (DAS) FOR MARINE AND ECOLOGICAL RESEARCH FROM AEROSPACE TECHNOLOGY

By Richard A. Johnson
Manager, MSU-MTF Research Center
Mississippi State University

Abstract

This paper represents the efforts of researchers at Mississippi State University to utilize space-age technology in the development of a self-contained, portable data acquisition system for use in marine and ecological research. The compact, lightweight data acquisition system is capable of recording 14 variables in its present configuration and is suitable for use in either a boat, pickup truck, or light aircraft. This system will provide the acquisition of reliable data on the structure of the environment and the effect of man-made and natural activities on the observed phenomenon. Utilizing both self-contained analog recording and a telemetry transmitter for real-time digital readout and recording, the prototype system has undergone extensive testing at the Mississippi Test Facility (MTF). Currently undergoing component performance upgrading, the prototype system has been utilized in several environmental science investigations associated with air pollution investigations and weather modification. It is currently being used on the Eco-System Research Project for marine data acquisition.

Acknowledgment

The author gratefully acknowledges the contributions of Dr. Lewis R. Brown, Dr. Richard E. Forbes, Dr. Michael R. Smith, G. S. Pabst, and M. L. Jones to the development of this prototype system and the preparation of this paper. This work was accomplished under NASA Grant NGL 25-001-028, NGL 25-001-032 and NGL 25-001-040.

Introduction

The recent emphasis on environmental science research in the U.S. has provided substantial impetus to research programs in the general area of marine ecologies. Researchers are developing numerous prediction methods for use in the control of air pollution; prediction of ecological alterations

caused by pollutants in fresh water, estuaries, and the marine environment; detection of contaminants in aquatic and terrestrial ecological systems; and related phenomena. Airborne remote sensing has opened up almost unlimited horizons for the collection of resource data from aircraft and satellite platforms; however, at this stage of development the methods require sufficient amounts of accurate ground-truth measurements to substantiate the overall base line.

This paper presents the results of efforts by researchers at Mississippi State University to utilize space-age technology in the development of a self-contained data acquisition system for use in marine, ecological, and environmental research. The system was originally developed at the NASA/MTF with the aid of personnel provided by the MTF contractor, the General Electric Company. The basic system was developed with off-shelf components and excess aerospace assemblies and was initially designed to be mounted in a light, single-engine aircraft to provide economical operation for small investigations in atmospheric diffusion and weather modification. In addition, the data acquisition and data processing facilities of the NASA/MTF were utilized to the maximum in providing real-time processing and graphical and tabular presentations of the experimental data.

The data acquisition system is capable of handling 18 independent measurements in its present configuration; however, onboard recording capability exists for only 14. The experimental data may be telemetered directly to the data handling center at the NASA/MTF or may be recorded onboard as the individual situation requires. Most of the equipment utilized in the development of the data acquisition was performing service in another capacity prior to its utilization in the present system.

System Development

Criteria. The development of the original Airborne Data Acquisition System (ADAS) resulted from

a direct requirement for experimental data to support results predicted by a computerized numerical simulation program. In addition, it was desired to use the data acquisition and data processing facilities at MTF and at the same time provide a system which could operate independently of these facilities in the data acquisition phase of an investigation. These considerations led to the development of an ADAS with both onboard recording and telemetry capabilities. In addition, it was desired to develop a self-contained system which did not depend upon the aircraft power and flight systems. This feature provides for a more flexible system in that it can be installed in an aircraft with either 12-volt or 24-volt electrical systems and also it is easier to satisfy Federal Aviation Regulations governing the installation of the ADAS in an aircraft.

Hardware Description. Development of component hardware was initially divided into three main categories: (1) equipment available directly usable or requiring only minor modifications, (2) equipment from outside procurements, (3) equipment requiring major modifications and/or new design. In order to satisfy the requirements delineated in the discussion on criteria, the main emphasis was on utilizing components which could be interfaced together with a minimum amount of design and fabrication requirements. The telemetry equipment obtained was an excess, Saturn V, third-stage rocket unit. The seven-channel analog recorder, power supplies, signal conditioners, resistance bridges, and the various sensing devices were procured separately. All interface equipment, antenna hardware, sensor and transducer mounts, remote control and monitor panel, and the overall system configuration was designed especially for this application and fabricated at MTF.

General Description of the Data Acquisition System

The assembled DAS is set up for a bench checkout in Figure 1. In the upper foreground is the telemetry transmitter unit and mixer amplifier (1); in the lower foreground is the medium gain signal conditioner amplifiers (2); and in the rear is the analog seven-track recorder (3); the left panel mounts resistance bridges and calibration, control, and interface patching (4); the special power supplies are floor mounted to the rear of this assembly (5); shown in the foreground is the remote power and control switches and the signal monitor display (6) mounted within close proximity to the operator, enabling the entire unit to be controlled in the cab of the boat, truck, or aircraft. The complete DAS is capable of being installed by two men in an 18-ft boat or pickup truck, with sensors mounted

in the water and calibration and ground check completed within 1 hour. The overall dimension of the electronics package is 25 by 27 in. and 14 in. high. The total weight of the DAS, including all equipment and sensors, is slightly less than 250 lb. The dc batteries are mounted in spillproof canisters.

Operational Mode

Airborne Operations. Flight operations were conducted during 1970 at the NASA/MTF to test the operation of the DAS and the quality of telemetry data received and processed by the MTF Data Handling Center (DHC). Numerous data runs were made at various times to flight check, calibrate and establish operating characteristics of the individual measurements. Extensive data collection was performed on rocket exhaust plumes during the static firings of the Saturn V first- and second-stage booster rockets at MTF. Pre- and posttest calibrations were run between the aircraft and the DHC to establish reliability and accuracy of data acquired during static-firing measurements.

Prior to an airborne mission, the ADAS is bench checked and calibrated in the laboratory, and the calibrations and operational characteristics are checked after installation of the ADAS in the aircraft. In most cases, it takes approximately 1 hour to warm up and ground check the unit.

Marine Operations. From June 1971 until the present, utilization of this system has been devoted to ecological and marine investigations. While this system can be utilized in a boat, truck, and aircraft, the initial phase has involved its use (mounted in a van) in the Eco-System Research Project area at MTF, within the function of Mississippi State University's Environmental Science Laboratory at MTF. This laboratory is part of the MSU Research Center and is dedicated to the solution of pollution problems in the Central Gulf South area. The Eco-System Research Project is a series of ponds and artificial streams wherein simulated ecological-systems can be studied. In these ponds, special sensor packages will continually measure selected parameters, which are transferred to the instrumentation van via cables and connected to the data acquisition system for analog recording or telemetry transmission to the DHC.

Processing of Acquired Data

Utilization of the MTF/DHC for processing of the acquired data has proved to be significantly advantageous

both from the standpoint of accuracy of the results and the speed of data reduction. For missions conducted within about 10 statute miles of the NASA/MTF, the acquired data are usually telemetered to the MTF/DHC for real-time processing and the analog recorder is used as a backup system. When missions are conducted farther away, they require the use of the analog recorder as the prime means of data acquisition, the analog tapes can be processed at either the MTF/DHC or other equivalent facilities.

The MTF/DHC has the capability to receive, condition, and record the data from an FM telemetry system using an analog receiving station and a Scientific Data SDS-930 digital computer system, or to replay a prerecorded tape through a wideband recorder and into the computer.

The digital data are corrected using calibration tapes and other established methodology resulting in a digital Engineering Units tape ready for storage and later retrieval or to be stripped out as hard copy data.

Application to the DAS to Environmental Science Investigations

The DAS has been used to obtain data in several environmental science investigations. Included in these investigations have been probings of the exhaust plume generated during the static firing of rocket engines, delineation of the structure of natural clouds under various meteorological conditions, quantitative contamination of aquatic and terrestrial ecological systems in support of studies directed toward predicting the ecological alterations caused by pollutants in fresh water, estuaries, and the marine environment.

The accepted data gathering procedure, prior to the introduction of this system to marine and ecological research, is best illustrated by Figure 2. Manual measurements require at least one individual, sometimes two, for each parameter measured, if they are to be performed simultaneously. Compromises must be worked out as the amount of personnel required to make 6-12 discrete measurements, at the same time, would be unrealistic for most projects conducted in the field. The application then of this system to the problem of recording ecological data allows all parameters to be recorded simultaneously and utilizes only two individuals to operate the system.

The DAS was designed originally to acquire data related to the growth and dissipation of rocket exhaust plumes, which are generated during the static firing of the S-IC and S-II rocket engines. The exhaust cloud, or plume, generated during the static firing has many characteristics which resemble a natural cloud. Considerable interest has been exhibited toward the possibility of using this isolated cloud as a well-defined model for weather modification research. These interests are directed at both the modification precipitation and electrostatic discharge in natural clouds and thunderstorms. In addition, the exhaust cloud could cause an air pollution problem in the event that toxic additives are used in the propellants. It was desired to determine the diffusion characteristics of the exhaust plume of various rocket engines under various meteorological conditions.

The investigations on the effect of various meteorological conditions on the structure of natural clouds were conducted in approximately the same manner as for the rocket exhaust clouds. The primary difference in the nature of the operations was that the natural cloud missions often extended over 3- to 5-hour periods and over geographical locations up to 100-500 miles apart. In these cases it was desirable to recalibrate for each particular cloud probe, which would typically require 5-10 penetrations. The handling of such voluminous calibrations would be very difficult if manually recovered, but is expeditiously processed by computer and significantly increases the reliability of the output.

Research concerning the prediction of ecological alterations caused by pollutants in fresh water, estuaries, and the marine environment and by the contamination of aquatic and terrestrial ecological systems is greatly facilitated by accurate and timely data collection in the field through the use of Field Monitoring Systems (Fig. 3) utilizing the DAS. This would allow collection of data from field locations for subsequent use in simulating field conditions in the laboratory and pilot plant ecological systems. In addition, the immediate review and analysis of data acquired from the local environment would be available for use by local, State, and Federal planning functions for application to existing environmental problems.

Conclusion

The DAS discussed herein represents a unique application of aerospace technology and excess hardware to problems in the environmental sciences.

The development of the DAS has provided an economical means of obtaining ecological, marine, and meteorological data using this portable system in a boat, truck, or aircraft.

The utilization of the data processing facilities at the NASA/MTF, in conjunction with the airborne data acquisition missions, has provided a real-time data processing capability which is extremely valuable for basic research investigations and programs which involve the evaluation and development of sensors and sampling techniques.

The availability and accessibility of Government excess equipment, with the unique innovations of application engineering and aerospace technology, provide the low-budget researcher a level of capability never before attained. Since most university-sponsored research is through State or Federal funding, this gain in capability and knowledge, and

at the same time minimizing overall project cost, provides continuing benefits from the aerospace program long after the need of the original application has expired. Any enhancement to the transference of environmental science research into useable application toward solving the pollution and the ecological problems facing the South Gulf area in particular, and the U.S. in general, will be an immediate benefit to us all.

References

1. Phase Coherent Frequency Synthesizer Technical Manual. NRL Contract N-00014-69-C-0117, 1970.
2. Report of Department of Transportation Air Traffic Control Advisory Committee. Alexander Report, 1969.

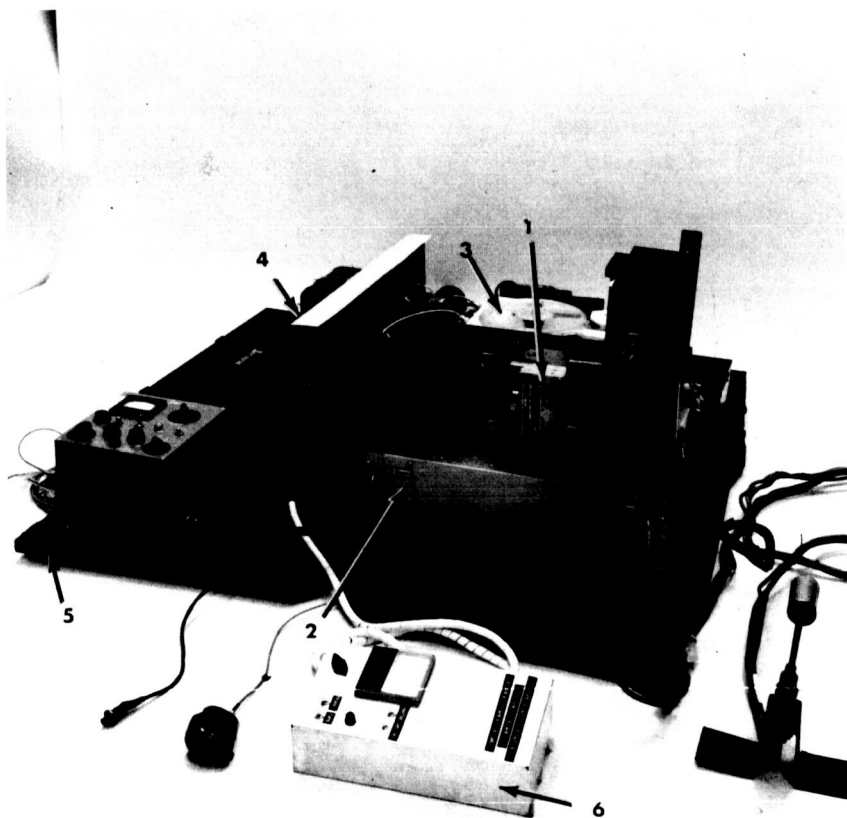

Figure 1. Marine Data Acquisition System (DAS).



Figure 2. Former data gathering procedure (manual method).

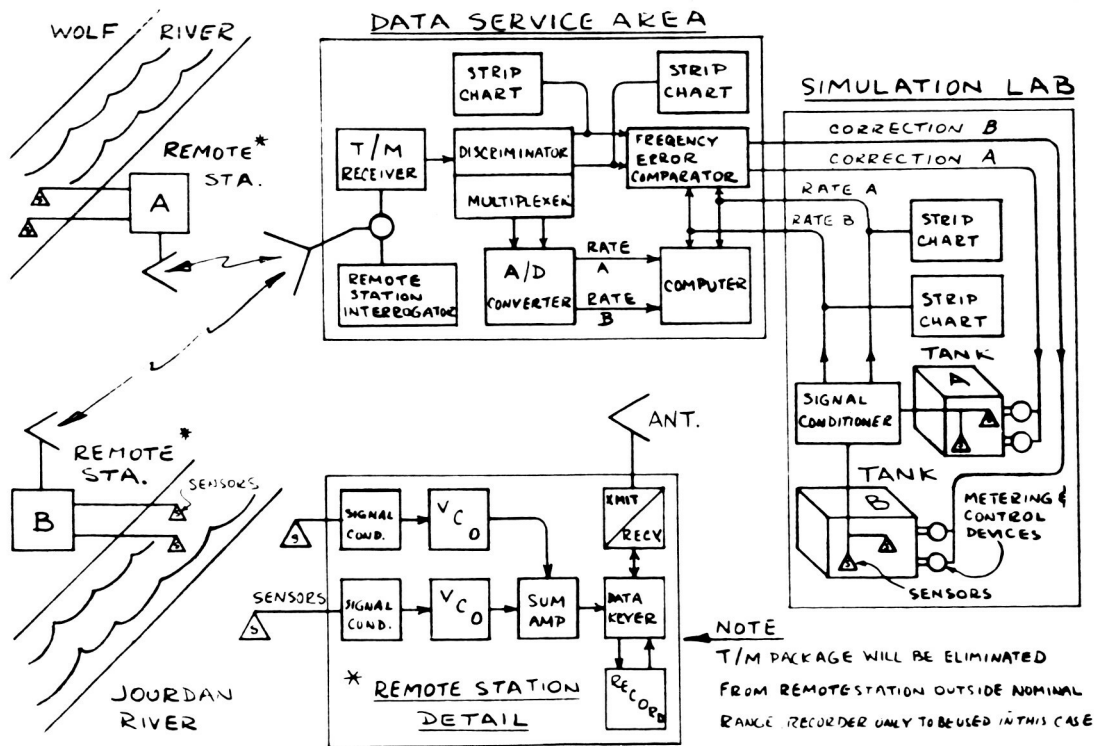

Figure 3. Field Monitoring Systems.