

**Hamilton
Standard**

U
DIVISION OF UNITED AIRCRAFT CORPORATION
A®

N73. 27945

SVHSER 6182

CR-133977

WASTE COLLECTION SUBSYSTEM DEVELOPMENT

BY

JOSEPH E. SWIDER, JR.

PREPARED UNDER CONTRACT NO. NAS 9-12150

BY

**CASE FILE
COPY**

HAMILTON STANDARD

DIVISION OF UNITED AIRCRAFT CORPORATION

WINDSOR LOCKS, CONNECTICUT

FOR

NATIONAL AERONAUTICS AND SPACE ADMINISTRATION

JOHNSON SPACE CENTER

HOUSTON, TEXAS 77058

FEBRUARY 1973

**Hamilton
Standard**

U
DIVISION OF UNITED AIRCRAFT CORPORATION
A®

SVHSER 6182

ABSTRACT

WASTE COLLECTION SUBSYSTEM DEVELOPMENT

BY

JOSEPH E. SWIDER, JR.

FEBRUARY 1973

This report describes the engineering studies, design activity and testing associated with the development of a waste collection system to accommodate both male and female crewmembers in a space environment. This system was developed under Contract NAS 9-12150, Waste Collection Subsystem Development.

**Hamilton
Standard**

U
DIVISION OF UNITED AIRCRAFT CORPORATION
A®

SVHSER 6182

WASTE COLLECTION SUBSYSTEM DEVELOPMENT

BY

JOSEPH E. SWIDER, JR.

PREPARED UNDER CONTRACT NO. NAS 9-12150

BY

HAMILTON STANDARD

DIVISION OF UNITED AIRCRAFT CORPORATION

WINDSOR LOCKS, CONNECTICUT

FOR

NATIONAL AERONAUTICS AND SPACE ADMINISTRATION

JOHNSON SPACE CENTER

HOUSTON, TEXAS 77058

FEBRUARY 1973

FOREWORD

This report has been prepared by the Hamilton Standard Division of the United Aircraft Corporation for the National Aeronautics and Space Administration's Johnson Space Center in accordance with the requirements of Contract NAS 9-12150, Waste Collection Subsystem Development. The report covers the work accomplished during the period 1 July 1971 through 31 December 1972, in the development of the Waste Collection Subsystem. The basic objective was to design and build a Development Waste Collection Subsystem and to obtain operational data from parametric and manned tests and design data from concept and design studies.

Personnel responsible for the conduct of this program were Mr. F. H. Greenwood, Program Manager, and Mr. J. E. Swider, Jr., Engineering Project Manager. Appreciation is expressed to Mr. A. Boehm, Design Engineer, Mr. E. Auerbach, Analytical Engineer, Mr. K. C. Jones, Human Factors Engineer and Mr. J. Raye, Reliability Engineer of Hamilton Standard and Mr. A. Behrend, Technical Monitor for NASA JSC, whose efforts made the successful completion of this program possible.

A special note of appreciation is extended to the various test volunteers at Hamilton Standard and the University of Connecticut Health Center, whose outstanding cooperation during the conduct of test programs helped to make this a successful program.

TABLE OF CONTENTS

	<u>Page No.</u>
<u>SUMMARY</u>	1
<u>INTRODUCTION</u>	3
<u>CONCLUSIONS</u>	5
<u>RECOMMENDATIONS</u>	7
<u>DISCUSSION</u>	9
DESIGN STUDIES	9
<u>Urine Elimination Study</u>	9
Objective	9
Summary of Results	10
<u>Seat Design Study</u>	23
Objective	23
Summary of Results	23
<u>Post Elimination Cleansing Study</u>	25
Objective	25
Summary of Results	30
<u>No-Vent Requirement Study</u>	30
Objective	30
Summary of Results	35
<u>Vomitus Collection Study</u>	41
Objective	41
Summary of Results	41

TABLE OF CONTENTS (Continued)

	<u>Page No.</u>
<u>Waste Sampling Study</u>	43
Objective	43
Summary of Results	43
Waste Sampling Concepts	44
<u>Fail Operational-Fail Safe Design Study</u>	47
Objective	47
Summary of Results	47
<u>Maintainability Study</u>	48
Objective	48
Summary of Results	51
<u>Space Vehicle Integration Study</u>	53
Objective	53
Summary of Results	53
DEVELOPMENT UNIT DESIGN AND FABRICATION	58
<u>Urinal Concept Evaluation</u>	58
<u>Seat Concept Evaluation</u>	62
<u>Feces Processing Selection</u>	62
<u>System Description</u>	67
<u>Commode Assembly</u>	67
<u>Waste Collection Subsystem Control Assembly</u>	69
<u>Anal Wash Kit</u>	72
<u>No-Vent Kit</u>	72

TABLE OF CONTENTS (Concluded)

	<u>Page No.</u>
DEVELOPMENT WASTE COLLECTION SUBSYSTEM GROUND TESTS	74
<u>Functional and Parametric Tests</u>	74
Functional Tests	74
Parametric Tests	76
<u>Twenty-Eight Man-Day Tests</u>	84
Twenty-Eight Man-Day Test (Normal Operation)	84
Twenty-Eight Man-Day Test (No-Vent Operation)	86
Commode Inspection and Cleaning	86
<u>University Testing</u>	92
Anal Wipe Test	92
Anal Wash Test	97
Commode Inspection	98
<u>RELIABILITY</u>	109
<u>SYSTEM SAFETY</u>	111
<u>INTERFACE REQUIREMENTS</u>	113
APPENDIX A <u>OPERATIONAL REQUIREMENTS</u>	A-i
APPENDIX B <u>SAMPLE TEST SUMMARY DATA SHEET</u>	B-i
APPENDIX C <u>FAILURE MODE AND EFFECTS ANALYSIS</u>	C-i

LIST OF FIGURES

<u>Figure No.</u>	<u>Title</u>	<u>Page No.</u>
1	Urine Collection Flow Patterns Tested with Water in Zero-Gravity	11
2	The Effect of Flow Pattern-A on Residual Pooling	13
3	The Effect of Flow Pattern-B on Residual Pooling	14
4	The Effect of Flow Pattern-C on Residual Pooling	15
5	Liquid Transfer Along a Surface in the Zero-g Test Aircraft Environment	16
6	Maximum Allowable Urine Impact Angles For Effective Splash Containment	18
7	Concept No. 1 - Baseline Urinal	19
8	Concept No. 2 - Baseline With Flow Limiter	20
9	Concept No. 3 - Two Position Urinal	21
10	Concept No. 4 - Variable Area Concept	22
11	Seat Configuration Based on Anatomical Requirements	24
12	Contour Requirements for the Tuberosity Support Seat	26
13	Concept No. 1	27
14	Concept No. 2	28
15	Concept No. 3	29
16	Vacuum Drying/Filtration Concept	36
17	Vacuum Drying/Catalysis Concept	37
18	Germicide/Storage Concept	38
19	Vomitus Collection Portable Disposable Collector (Bag)	42

LIST OF FIGURES (Continued)

<u>Figure No.</u>	<u>Title</u>	<u>Page No.</u>
20	Sampling Concept No. 1	45
21	Sampling Concept No. 2	46
22	Sampling Concept No. 3	47
23	Integrated Vacuum Drying Process Flight System Schematic for Fail Op - Fail Safe Requirements	49
24	Test Set-up Used in Seat/Urinal Subjective Evaluations	59
25	Selected Urinal Configuration (Cross Section)	63
26	Selected Urinal/Seat Configuration Installed on Commode	64
27	Development Waste Collection Subsystem Schematic	68
28	Waste Collection Subsystem Control Panel	71
29	Anal Wash Kit Control Panel	73
30	Hamilton Standard WCS Test Installation	75
31	SVSK 85029 Vortex Liquid/Air Separator (Cross Section)	77
32	Feces and Wipe Distribution in Commode After Ground Tests at Hamilton Standard (Top View)	88
33	Feces and Wipe Distribution in Commode After Ground Tests at Hamilton Standard (Side View)	90
34	Commode Air Outlet Screen and Inlet Diffusion Area After Ground Tests at Hamilton Standard	91
35	University Testing WCS Test Installation	93
36	University Testing WCS Test Installation with Anal Wash Kit	100
37	Feces and Wipe Distribution in Commode After University Testing (Top View)	105

LIST OF FIGURES (Concluded)

<u>Figure No.</u>	<u>Title</u>	<u>Page No.</u>
38	Feces and Wipe Distribution in Commode After University Testing (Side View)	106
39	Commode Air Outlet Screen and Inlet Diffusion Area After University Testing	107

LIST OF TABLES

<u>Table No.</u>	<u>Title</u>	<u>Page No.</u>
I	Perineal Cleansing Study Matrix for Wipes Versus Douche	31
II	No-Vent Concept Evaluation	39
III	Fail Operational - Fail Safe Features	50
IV	Space Shuttle and Space Station Waste Management Requirements	54
V	Candidate System Compliance With General Waste Management Requirements	55
VIA	Space Shuttle Evaluation with Gas Venting Permitted	56
VIB	Space Shuttle Evaluation with Gas Venting Prohibited	56
VII	Space Station Evaluation with Gas Venting Prohibited	57
VIII	Urinal Concept Evaluation Data Sheet	60
IX	Urinal Concept Evaluation Summary	61
X	Commode Seat Evaluation Data Sheet	65
XI	Commode Seat Evaluation Summary	66
XII	Parametric Testing - Subjective Comments Baseline/Failure Mode Test - Centering Jets Inoperative	78
XIII	Parametric Testing - Subjective Comments Position Variation Test	79
XIV	Parametric Testing - Subjective Comments Diarrhetic Movement	81
XV	Parametric Testing - Subjective Comments Commode Attitude Test	83
XVI	28 Man-Day Tests - Subjective Comments Normal Operation	85
XVII	28 Man-Day Tests - Subjective Comments No-Vent Operation	87

LIST OF TABLES (Concluded)

<u>Table No.</u>	<u>Title</u>	<u>Page No.</u>
XVIII	University Tests - Subjective Comments Anal Wipe Test	94
XIX	University Tests - Subjective Comments Anal Wash Test	99
XX	University Tests - Subjective Comments General	101

SUMMARY

This program by means of various engineering studies as well as the design and test of a total subsystem established the feasibility of a Waste Collection Subsystem (WCS) which closely resembles terrestrial equipment for spacecraft usage. Test results show that the system is practical for male and female usage, does not require the manual handling of metabolic wastes and that the use of tissue wipes for post-elimination cleansing is a viable method for spacecraft application. The test results also demonstrate the effectiveness of vacuum drying for feces processing. Vacuum drying provided odor-free storage without any evidence of microbiological activity throughout the ground test program. Other tests performed revealed that the WCS entrainment air odor control filters also were effective in controlling the odors generated by the vacuum drying of feces.

The various studies conducted initially in the program established that female urine collection would be the primary basis for urinal design and that a successful female collector would accommodate males as long as sufficient anatomical provisions were included. The studies also evaluated seat designs, post-elimination cleansing methods and methods of operation without venting to space vacuum. The results then were incorporated into the design of the development WCS. Additional studies relative to flight systems concluded that vacuum drying is the best method for feces processing for general spacecraft usage, evolved a fail-operational - fail safe flight system and evaluated various maintenance concepts for a Waste Collection Subsystem.

Ground testing of the WCS was conducted at Hamilton Standard and at the University of Connecticut Health Center. The tests demonstrated that the commode feces and wipe storage capacity is far in excess of that required for the 42 man-day Space Shuttle mission requirement. The unit was approximately 50 percent filled after completion of parametric tests plus two 28 man-day tests and again after completion of two 60 man-day tests, indicating a capacity on the order of 150 man-days. Wipes were found to be a practical cleansing method for the user. Some soiling of the commode was found after particularly loose defecations or when the user was not positioned properly. This soiling was minimal and of the type that could be cleaned easily by a wipe. Some difficulty in having the wipes shredded by the slinger in the commode resulted in poor packing of the feces and wipes within the storage area. It is believed that better control of the amount of wipes and the type of wipes would eliminate this problem.

Testing conducted at the University of Connecticut Health Center by six male and six female medical students revealed that while the system was somewhat strange and inhibiting initially, the test volunteers became accustomed to it and thought it an acceptable device for use. Subjective dislikes were

concerned primarily with fan noise and the fact that a specific operating procedure was required. The subjective evaluation of tissue wipes versus an anal wash for post elimination cleansing revealed that the wipe method was preferred, and that further effort would be required to make the anal wash effective.

The Development Waste Collection Subsystem performed without failure throughout the total test program and met all program objectives successfully. The system now is ready for further development, which should include zero-gravity testing and further design optimization of the overall system.

INTRODUCTION

Previous concepts for waste management have placed emphasis on collection and storage of human wastes in a zero-gravity environment for male crewmen only. In addition, these methods of waste collection and storage have been less than desirable in the human and operational aspects and have required manual handling of metabolic wastes. With the arrival of the Space Shuttle program, accommodations that are as earthlike as possible in the human and operational aspects for both male and female crewmembers and passengers in both zero- and one-gravity environments are required.

As a result the NASA initiated the Waste Collection Subsystem Development Program, Contract NAS 9-12150 to address a number of the important Space Shuttle waste management problems that had not yet received attention. The most significant of these problems and desired characteristics were:

- Waste collection from females.
- Collection of simultaneous urination and defecation.
- Elimination of manual handling of waste products.
- Operation in both zero and one "g".
- Earth-like equipment.
- Simplicity of operation.

In order to evolve successful solutions to these specific Space Shuttle waste management problems, incorporating the desired system characteristics, Hamilton Standard drew on several years of experience in designing and developing waste management and other life support equipment for manned space programs. Activity conducted under the Space Station Prototype program, specifically the design building and testing of a waste collector and the knowledge gained from the Personal Hygiene System Study, were directly applied to the WCS development activity. The NASA Langley Research Center/Hamilton Standard Space Shuttle EC/LSS Study and contractual and unfunded support of the Space Shuttle prime contractor provided knowledge on a system level required for this program. Complementing these efforts was an IR&D Waste Management Program which among other things confirmed analysis that for females it was possible to separate the collection of urine and feces.

A methodical technical approach to the WCS development accentuating the previously identified critical Space Shuttle problems was utilized in performing the program. The various critical areas were carefully defined and engineering studies accomplished to evolve problem solutions. Where required, design feasibility testing was conducted both in zero and one "g". Various hardware concepts were manufactured and evaluated technically and subjectively to determine optimum configurations. The detailed results of the engineering studies have been published previously and are summarized within this report.

The WCS Development Unit was then designed and built with a degree of sophistication which allowed the maximum use of commercial-grade hardware, thus minimizing costs without compromising program objectives. A comprehensive series of ground tests was conducted on the Development WCS. Over two hundred man-days of testing were accomplished at Hamilton Standard and at the University of Connecticut Health Center, in Farmington, Connecticut. The test results verified that all the problems of the Space Shuttle Waste Subsystem could be solved and that it was feasible to collect waste products from male and female crewmembers in a simple, efficient, earth-like manner in a spacecraft environment.

CONCLUSIONS

The results of this program effort to design, build and ground test a Development Waste Collection Subsystem led to the following conclusions:

- Urine collection from both male and female crewmembers in a spacecraft environment in a terrestrial manner without intimate contact or manual handling of wastes is feasible.
- Design criteria for urine collection must be based on the ability to collect from females. Any system that is workable for females will be usable for male collection.
- Testing indicates that for successful female urine collection in zero-gravity two distinct air entrainment flow streams are required; 1) a primary stream drawn down between the thighs providing an air velocity of 40 ft/sec in the vulva area and 2) a secondary stream providing 40 ft/sec air that is blown up onto the vulva area from the rear. The action of the two streams will collect and transport the urine to the storage area. Figure 25 depicts the urinal cross section designed for the development WCS.
- Urination was not inhibited by the use of the 40 ft/sec velocity air flows. Temperature was not a comfort problem unless room temperature fell below 70°F.
- Separate collection of urine and feces is practical with a sit-down type collector.
- The vacuum drying process utilized for feces processing performed well and exhibited excellent performance in drying the feces.
- The four inch diameter fecal collection opening and transfer duct were found to be acceptable for usage. Occasional soiling did occur in the transfer duct but this was usually due to either a loose movement or improper user position. Most soiling might have been eliminated if the anal wash capability were not present since a shorter transfer duct could then have been used.
- The commode was usable in a tilted attitude of up to 25° for urine and feces collection. Slight soiling of the lower portion of the feces transfer duct did occur requiring only minor cleansing. These results indicate that it would be feasible to install the commode in a tilted position, for utilization on the launch pad during launch delays.

- The feces air entrainment flow was 25 scfm throughout the various ground tests. No difficulties were experienced with this flow except when the test volunteers were located off-center of the fecal opening; then, the air flow tended to splatter the user with feces. The flow was not inhibiting except when the temperature dropped below 70°F, a situation similar to that described previously about the urine air entrainment flow.
- The capacity of the commode utilized in the WCS is well above the Space Shuttle 42 man-day requirement. Even with no limit on the quantity of wipes and the use of dry wipes, the capacity appears to be in excess of 150 man-days.
- The use of wipes for post-elimination cleansing and disposing of the wipes in the commode is a practical operation. However, it was found that the dry wipes did not shred and pack properly and more testing should be accomplished to investigate this potential problem area. Wet wipes and better control of the amount of wipes used offer an attractive solution.
- The test volunteers reported that the anal wash did not clean them satisfactorily after an elimination and that wipes were required to achieve effective cleansing. The test volunteers indicated that they did not like the use of the anal wash and preferred the use of wipes.
- The use of activated charcoal and "Purafil" filters for odor control was found to be very effective during the test series for both the urinal and commode air entrainment flow streams. The use of the same filters to control odors from the commode exhaust during the vacuum drying process also was successful.
- The vortex liquid/air separator used in the urine collection system was an effective method of separation during all the ground tests.
- The WCS, as tested, was found to be an effective waste collection system, generally acceptable to the various users. Several minor changes in the actual hardware should be made for improved operation, but the basic concepts evolved and incorporated into the design were proven successful and feasible.

RECOMMENDATIONS

The studies and test results of this program evolved the following recommendations:

- The vacuum drying method of feces processing should be considered a candidate process for the Space Shuttle Waste Collection Subsystem.
- The Space Shuttle Waste Collection Subsystem should employ a collector design incorporating the features of the collector used in the Development Waste Collection Subsystem described in this report.
- If the non-venting of gases to space vacuum becomes a requirement for the Space Shuttle Waste Collection Subsystem, a vacuum pump could be added to the system and vacuum drying still be accomplished for feces processing. The fecal gases exhausting from the vacuum pump should be passed through an activated charcoal and "Purafil" filter system to control odors. However, trade studies should be conducted to determine the optimum feces processing system to be utilized.
- The recommended post-elimination cleansing method for Space Shuttle application is the use of tissue wipes for both anal and vulva cleansing, with the wipes being disposed of in the commode.
- The following changes should be added to the next generation Development WCS, in addition to any system optimization:
 - 1) Insure that the commode pressure equalization time prior to use is within fifteen seconds.
 - 2) Increase the pressure of the centering jets to allow their flow to be felt above the entrainment flows.
 - 3) Install an easily removable and cleanable filter downstream of the urinal and upstream of the liquid/air separator to trap any debris or wipes inadvertently dropped into the urinal.
 - 4) Remove the anal wash capability in the commode.
- Additional study, design and test efforts should be performed in the following areas:
 - 1) Zero-gravity testing of the urine collector, feces collector and vortex liquid/air separator to verify the results of the analyses and ground tests performed in this program and the suitability of the equipment for spacecraft usage.

- 2) Testing of wet wipes to evaluate packing capability, improvement in adhesion properties and amount required.
- 3) Determine if the interior wall of the commode can be changed to improve the adhesion properties of a wipes-feces mixture.
- 4) If the anal wash system is pursued, determine the optimum water spray pattern, water pressure and water temperature to make the system effective from the cleansing and user acceptability aspects.
- 5) Determine the optimum size of the commode to be utilized in the Space Shuttle.
- 6) Determine the optimum size of the odor control filters for a nominal spacecraft mission, both for entrainment air odor control and control of fecal gases in a no-vent operating mode.

DISCUSSION

The discussion of the results obtained from this program is divided into three major task areas: Design Studies, Development Unit Design and Fabrication, and Development Unit Ground Tests. These major tasks, corresponding to the program work breakdown structure, have several associated subtasks, each of which is discussed in detail. A summary of the reliability and safety efforts and the interface requirements of the WCS is included in the discussion section.

DESIGN STUDIES

The following design studies were conducted to define viable concepts and establish requirements to apply to the development unit WCS and to the eventual flight Space Shuttle Waste Collection Subsystem. Appropriate design feasibility tests were conducted as necessary to support the study efforts.

- Urine Elimination Study
- Seat Design Study
- Post Elimination Cleansing Study
- No-Vent Requirement Study
- Vomitus Elimination Study
- Waste Sampling Study
- Fail Operational - Fail Safe Design Study
- Maintainability Study
- Space Vehicle Integration Study

The first six studies listed above are specifically applicable to the WCS Development Unit in addition to establishing general waste collection criteria. Prior to the start of the WCS Development Program, Hamilton Standard had initiated a Shuttle Waste Collection Development Program as part of an overall IR&D Waste Management Program. The results of that IR&D effort provided the basis for the specific and general waste collection criteria established in the aforementioned design studies. The last three studies are oriented toward flight system requirements. The studies are discussed in summary in this report. They are reported in detail in Hamilton Standard Report SVHSER 5905, Waste Collection Subsystem Engineering and Technical Data Report, of Contract NAS 9-12150.

Urine Elimination Study

Objective

The objective of this study was to determine and evaluate all factors that influence urine elimination for both males and females and to utilize

the information obtained to conduct any analysis and design feasibility testing required during the generation of urine collector concepts.

Summary of Results

In a space environment where the effect of gravity is neutralized, a urinal design must incorporate other features than just being a receptacle. The design must eliminate any urine splashback into the cabin atmosphere, incorporate an air entrainment method that insures the urine will enter the urinal and also transport the urine to the storage/disposal area. It was determined that the best way to properly address all the problems associated with urine elimination was to utilize zero-gravity testing. A test series was conducted using the KC-135 Zero-G Test Aircraft at Wright-Patterson Air Force Base. The objective of the tests was to investigate the properties of fluids in the absence of gravity and to establish entrainment flows, velocities and patterns required to capture and move urine from crew members to the storage/disposal equipment.

The following results and general conclusions were reached as a result of the zero-g test program and study.

1. A controlled air flow, velocity and direction, will be required to contain and transfer urine and flush water.
2. All urine that is expelled from the body with some expulsion force will be contained by the air flow and urinal walls.
3. In the case of female crewmembers, as much as 30 ml. of urine may leave the urethral opening with such low expulsion force that in zero-gravity it will accumulate in a large globule in the vulva area.
4. The air flow required to minimize residual urine on the female will determine the local velocities on the skin areas. Males normally do not expel more than a few drops of urine with low pressure. The tests indicated no problem would be experienced collecting from the penis at velocities as low as 25 ft/sec.
5. The urine residual on the skin can be minimized by a controlled air flow over the vulva area; the quantity of residual is a direct function of the local air velocity. Three basic flow patterns which could produce the desired force on the torso were tested and are illustrated in figure 1. In Pattern -A, the flow follows the torso and is drawn into the collector. This generates a pulling force on the urine globule, similar to the action of a vacuum cleaner. In Pattern - B, an attempt is made to reduce the required shearing forces by first starting the urine in motion along the torso, similar to the way urine travels in a one-g environment. In Pattern-C, shearing forces are enhanced by flow nozzles. Air from the nozzles impinges

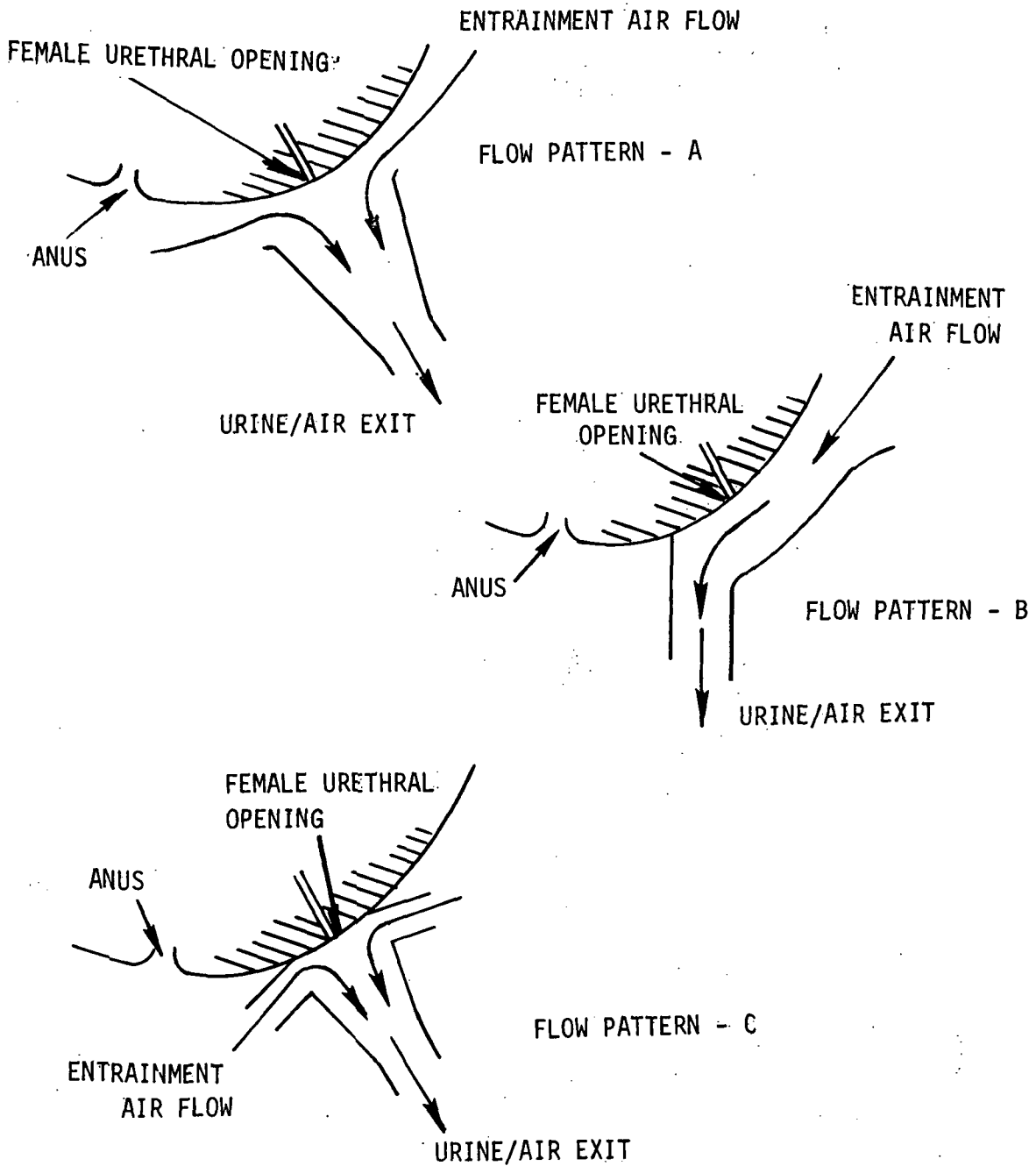

URINE COLLECTION FLOW PATTERNS TESTED WITH WATER IN ZERO-GRAVITY

FIGURE 1

directly on the skin, creating a wedging action between the skin and urine. The test series determined that water could be removed from the body by use of each of the flow concepts but that none of the methods could remove all the water in the flow ranges tested, which were 25 to 80 ft/sec velocity. Flow Pattern - C was selected because it minimized the residual urine by use of the directional air nozzles. Figures 2, 3, and 4 depict the results obtained with each of the flow patterns.

6. An air entrainment velocity of 40 ft/sec in the vulva/scrotum area was selected as the initial design point for residual urine removal from the skin. This choice was more because of the liquid action under the higher air velocities than the absolute quantity of the liquid residual. The water droplets were deformed and blown about more at the higher flow conditions (50 to 80 ft/sec). The droplets were unstable as they were removed from the skin, and splattering was noted on the collector walls. This phenomenon was significantly reduced in the medium air flow range (30 to 40 ft/sec) and eliminated under lower flows. The residual pooling was less than 6 ml. in all test cases at 40 ft/sec flow velocity. At the higher air flows 5 ml remained. The choice of 40 ft/sec results in only a marginal sacrifice in absolute performance. This is more than compensated for by the increased control in removing the residual.
7. The residual urine remaining on the female vulva area with the 40 ft/sec air velocity will be removed by the use of tissue wipes. The residual will be relatively easy to wipe with a tissue because the pubic hair and the recess of the labial folds act to contain the small amount of residual in the area. The action of the pubic hair in containing the residual precludes any necessity to shave the pubic area.
8. The local air velocity needed to transport urine and flush water to the storage/disposal equipment was found to be 25 to 30 ft/sec. This was determined by establishing the velocities required in zero-gravity to move various droplet sizes along teflon and acrylic surfaces. The results of the tests are shown in figure 5. These curves show that large diameter water droplets (greater than 0.35 in.) can be moved with a velocity of 22 ft/sec on teflon and 25 ft/sec on acrylic. Moving smaller droplets requires the use of higher air velocities. The empirical curves agree fairly well with theoretical data, to the point that off-design data can be generated by using theoretical calculations involving empirical correction factors. Although the surface tension of urine is slightly higher than that of water, the degradation of hydrophobic surfaces with time makes it difficult to predict required air velocity values. This degradation occurs as surfaces become soiled or as the surface coating degrades. For this reason, 30 ft/sec is chosen as the initial design point for wall air velocities. This velocity will move all urine droplets greater than 0.35 in. in diameter and will be sufficient to move droplets larger than 0.35 in. even if a 35 percent degradation in performance is encountered. It may be noted that no attempt is made to move the

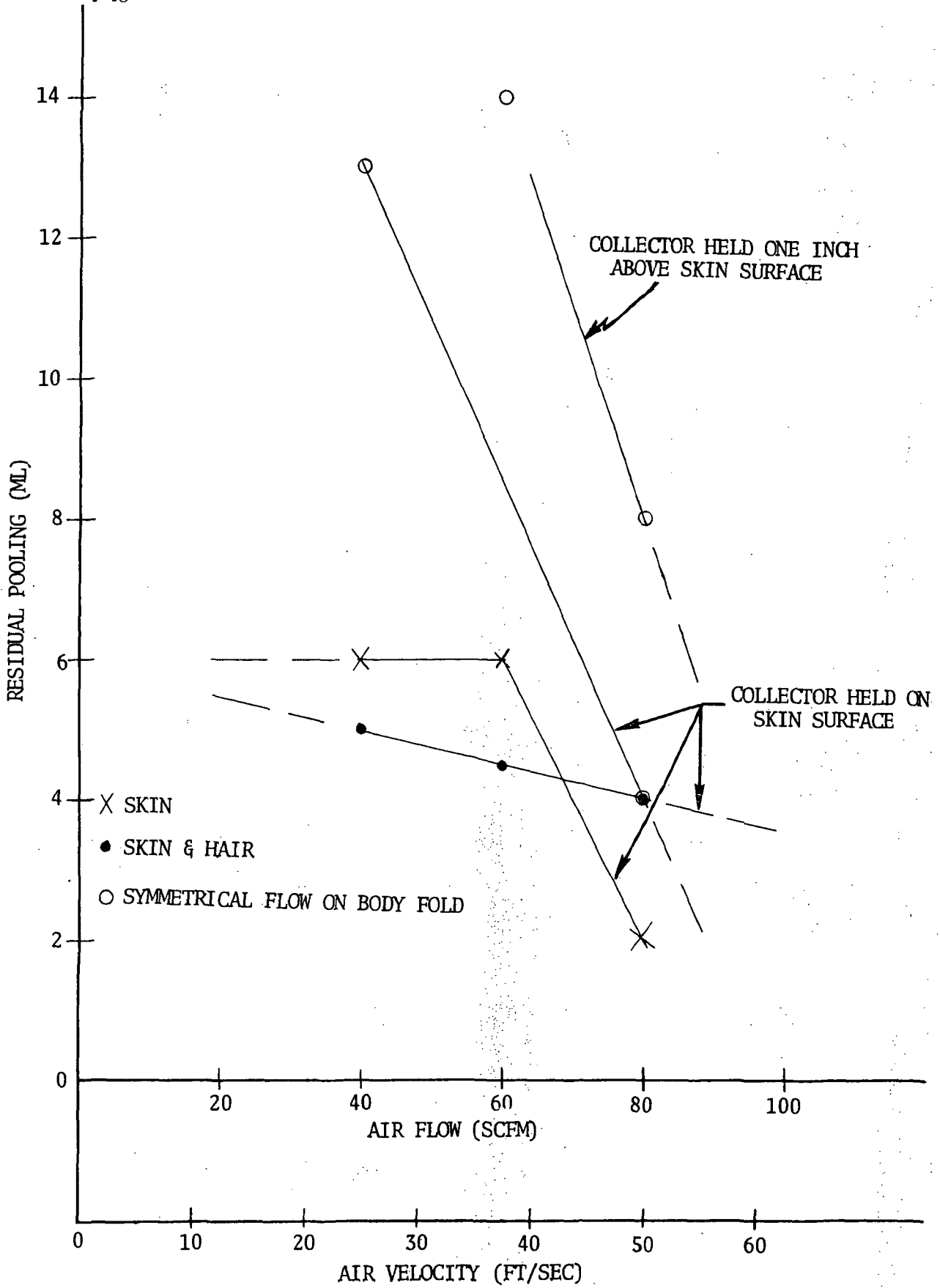

THE EFFECT OF FLOW PATTERN-A ON RESIDUAL POOLING

FIGURE 2

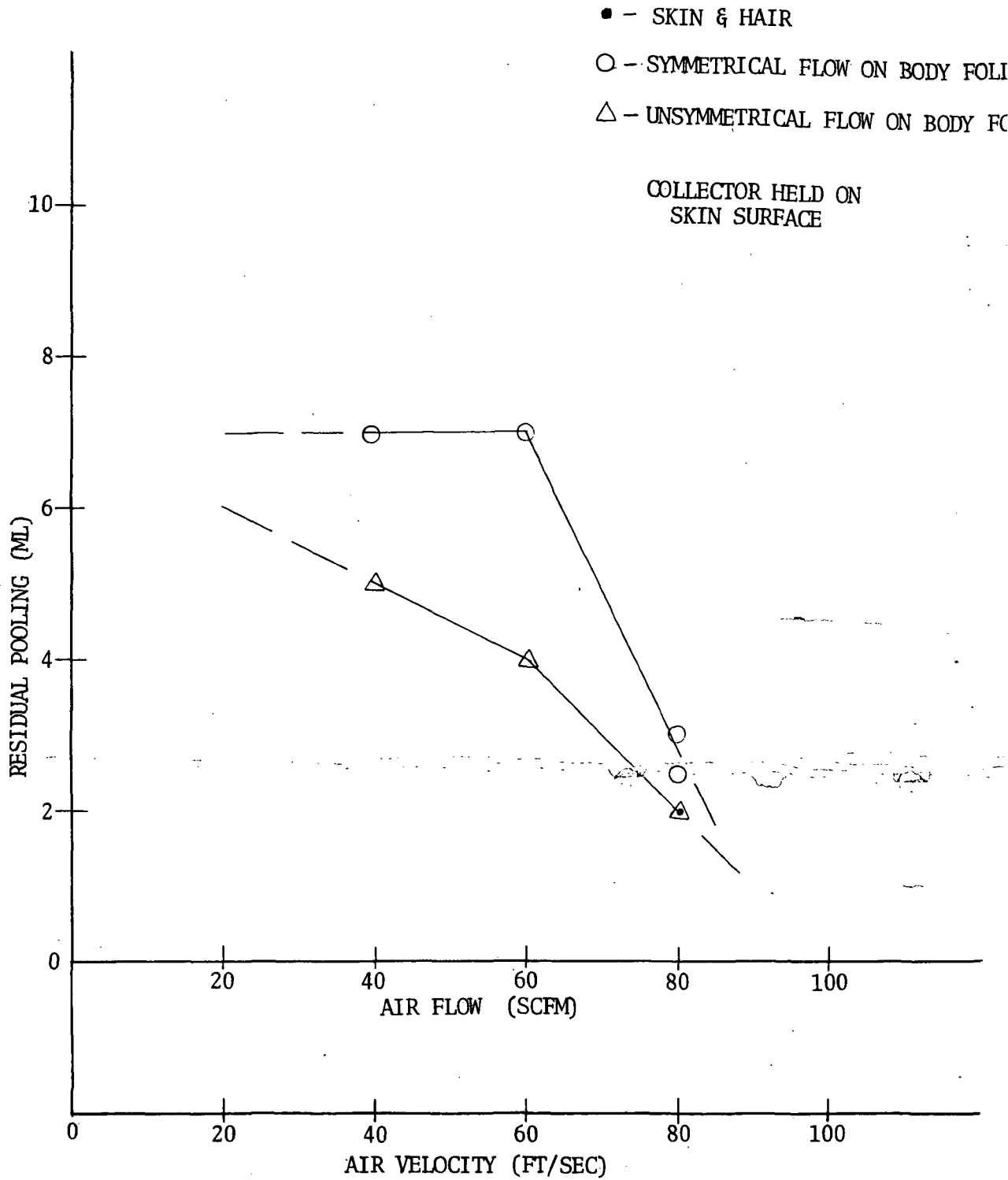

THE EFFECT OF FLOW PATTERN-B ON RESIDUAL POOLING

FIGURE 3

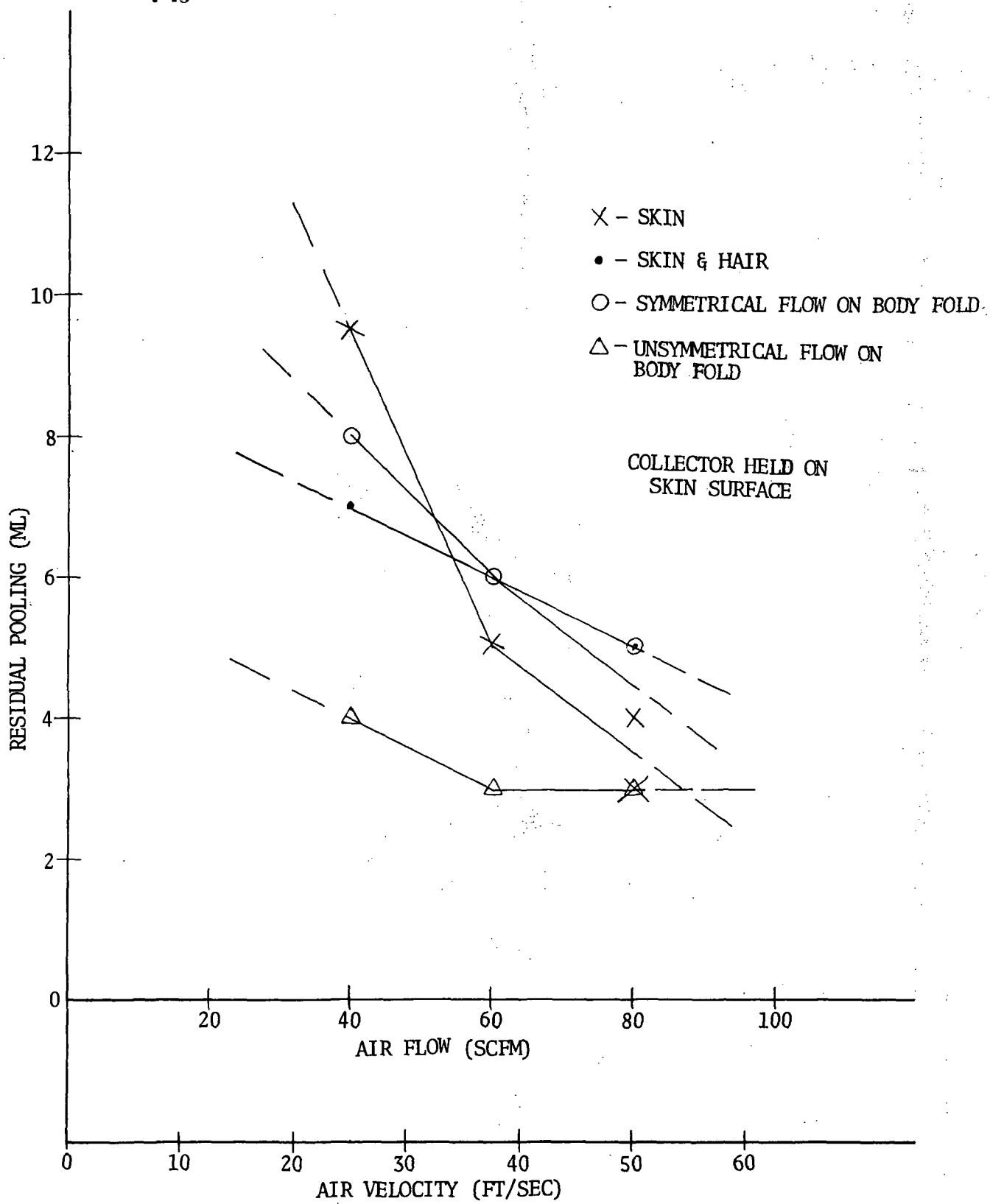

THE EFFECT OF FLOW PATTERN-C ON RESIDUAL POOLING

FIGURE 4

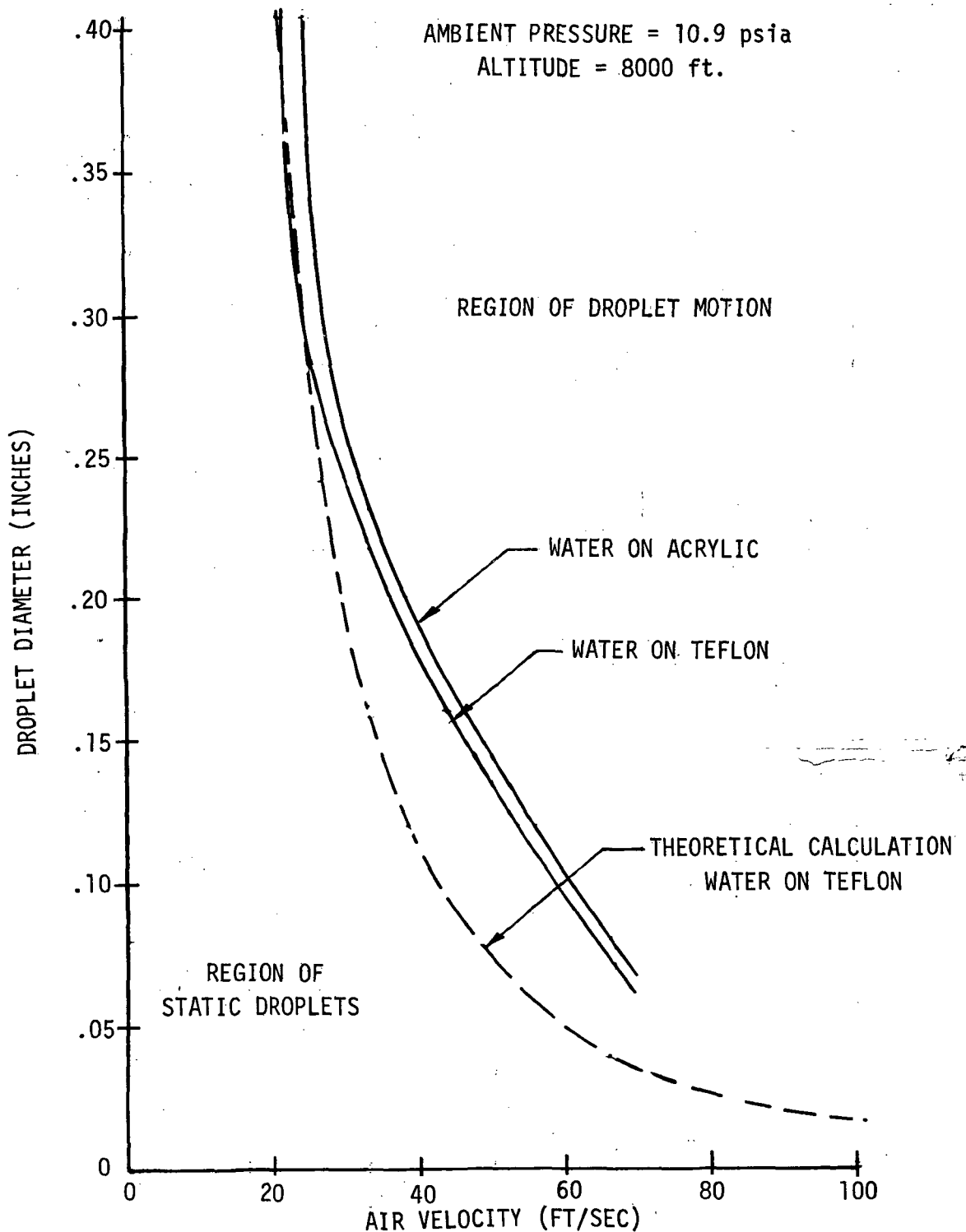

LIQUID TRANSFER ALONG A SURFACE
IN THE ZERO-G TEST AIRCRAFT ENVIRONMENT

FIGURE 5

urine splash, which consists of relatively small droplets. These droplets will be washed off by the flush water flow.

9. The contour and shape of the urinal are established by the need to accommodate the male genitals and the need to contain splashback of the urine. Testing has verified the ability to predict splashing for various droplet sizes analytically. Splashing in the urinal can be minimized by using a combination of design methods. One method is to establish urinal-wall contact angles for the range of urine-stream entry angles, which naturally reflect the urine stream at a low reflection angle. The closer the angle between the urine stream and the impact wall is to tangential, the smaller the amount of splashing will be. The second method is to direct all natural reflection angles of the urinal away from the urinal opening and toward the main exit duct. This method will reduce the amount of detrimental splashing. A third method is to provide air-flow streams that help to suppress splashing. Combining all these methods and having measured the maximum drop diameters in splash tests evolved the curve presented in figure 6. This figure is a plot of urine impact angles as a function of distance from the buttocks for various entrainment air flow velocities and can be translated directly into a urinal contour.

The results of this study permitted the generation of the four urinal concepts depicted in figures 7 through 10. Each configuration offers a variety of flow arrangements that are not necessarily unique to the configuration with which they are presented. In this way, flow limiting devices and nozzles may be combined with other urinal configurations to provide an increased number of concepts.

Concept No. 1: The first concept is shown in figure 7. This concept provides the basic shape that is needed to accommodate the male anatomy and to contain splashing. This concept has the features of a directed rear flow as shown in flow Pattern-C and of an air wash along the bottom surface to carry away the female urine stream. The main cabin air generates a flow pattern on the female previously identified as Pattern-A.

Concept No. 2: The second concept is shown in figure 8. This concept has the same general configuration as Concept No. 1. The major difference is the addition of a flow limiting device. This device generates the directed flow pattern previously tested as Pattern - C for both rear and front flow on the female. The device slides out of the way for female wiping and male usage. By using the flow limiter for all collection schemes the total air flow required is reduced. Even in the open position, male urine collection is effective because of the male's ability to divert his urine flow into the higher velocity outlet duct.

Concept No. 3: The third concept is shown in figure 9. This concept uses a small collector that moves to preset positions for male and female urination. For the female, the urinal is moved back until it contacts the feces

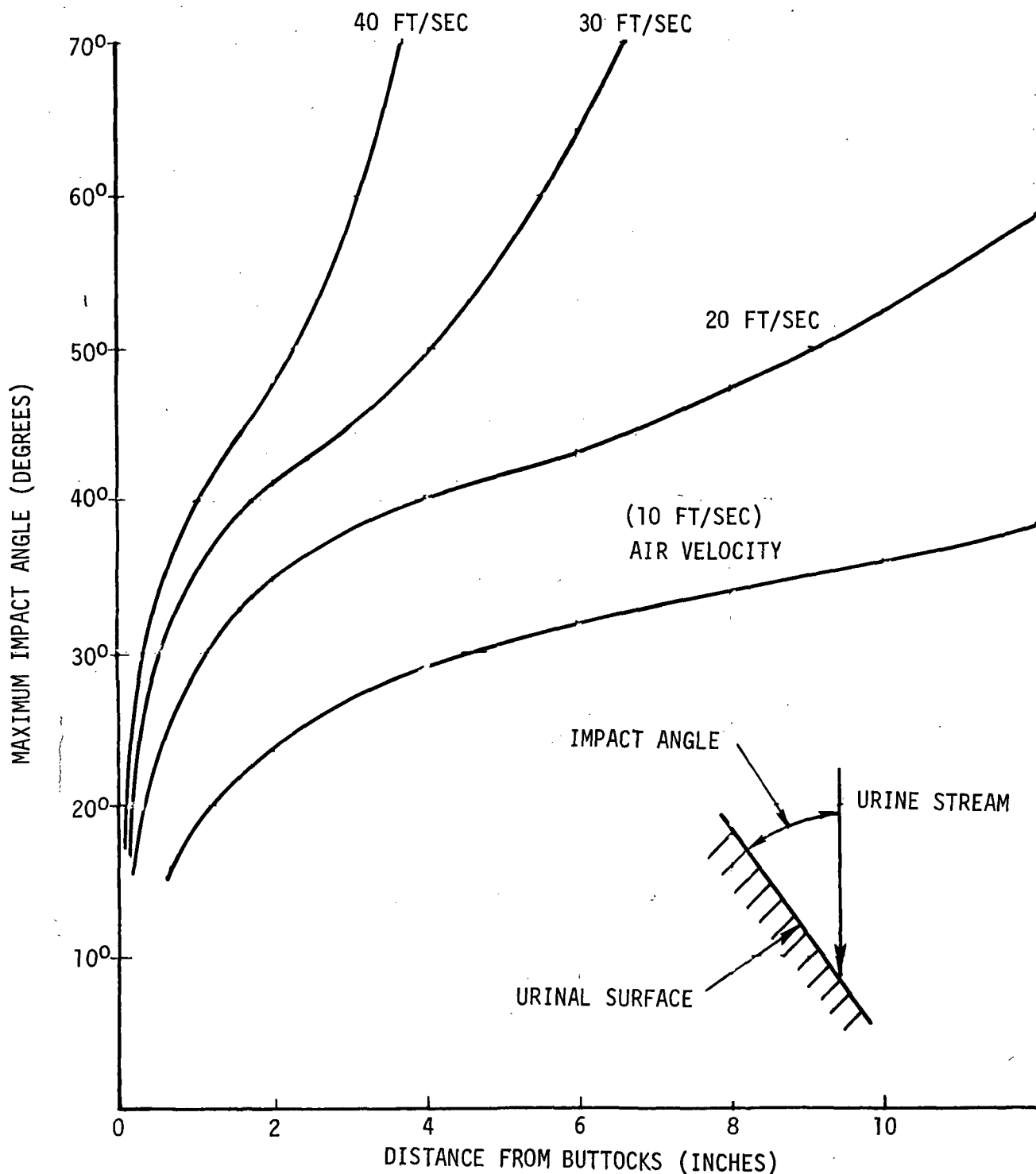

MAXIMUM ALLOWABLE URINE IMPACT ANGLES
FOR EFFECTIVE SPLASH CONTAINMENT

FIGURE 6

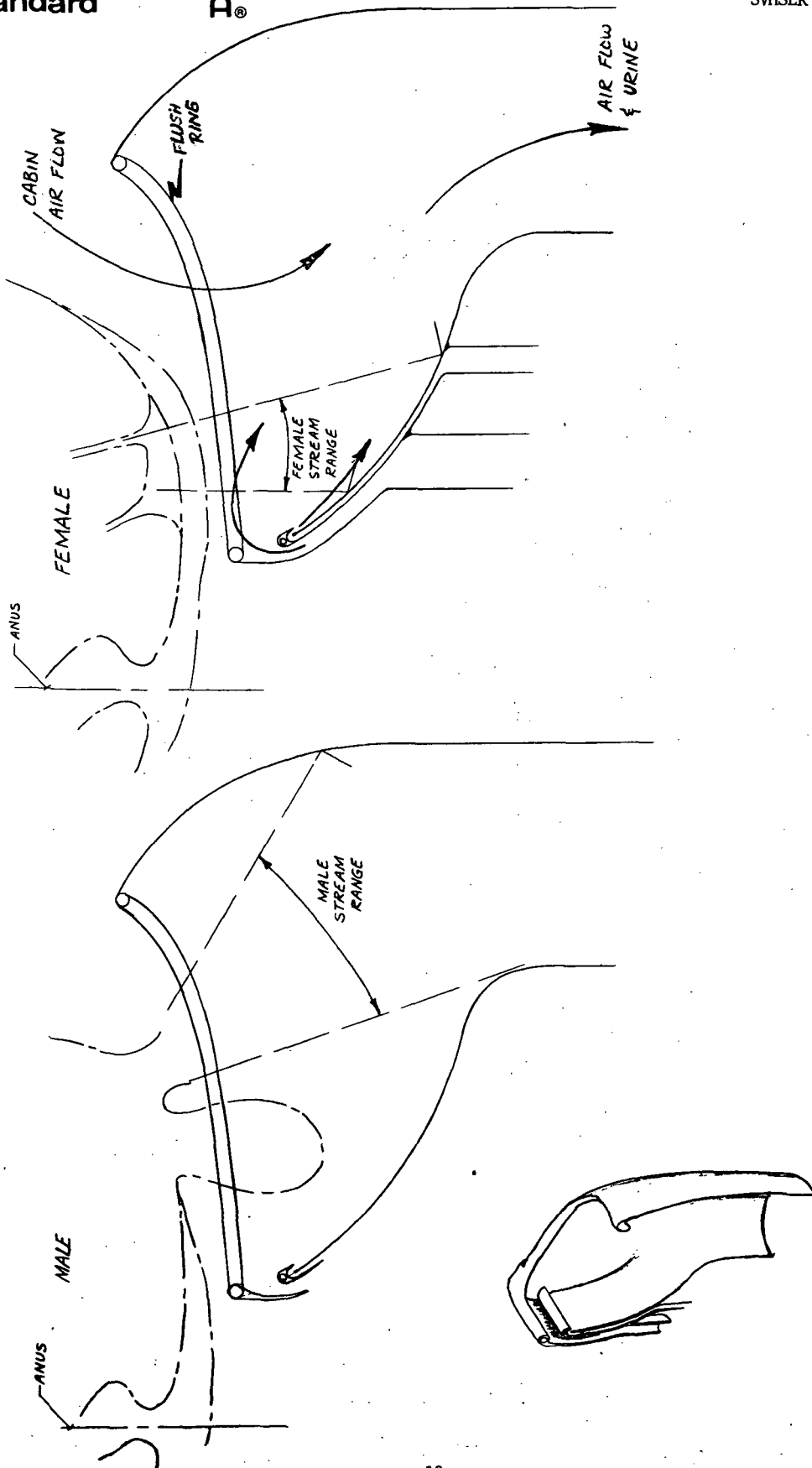

CONCEPT NO. 1 - BASELINE URINAL

FIGURE 7

Hamilton
Standard

DIVISION OF UNITED AIRCRAFT CORPORATION

U
A[®]

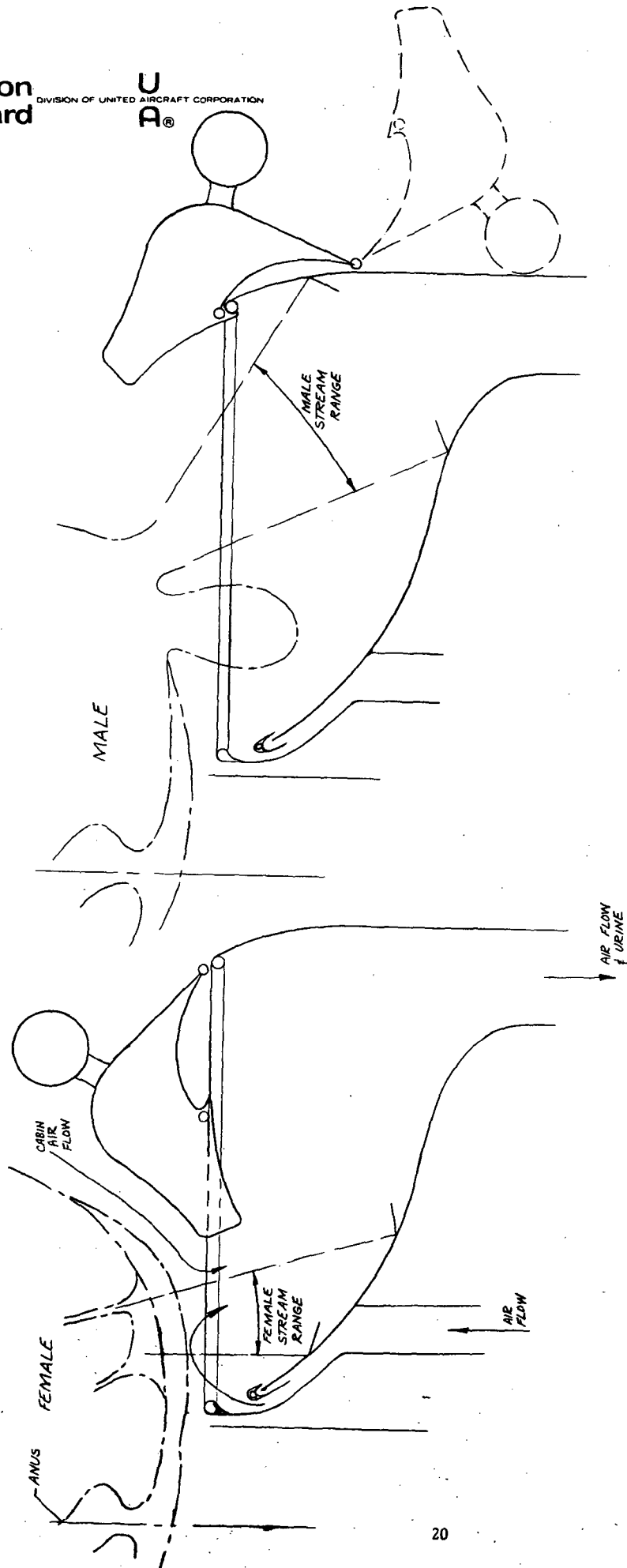

CONCEPT NO. 2 - BASELINE WITH FLOW LIMITER

FIGURE 8

Hamilton
Standard

U
A[®]
DIVISION OF UNITED AIRCRAFT CORPORATION

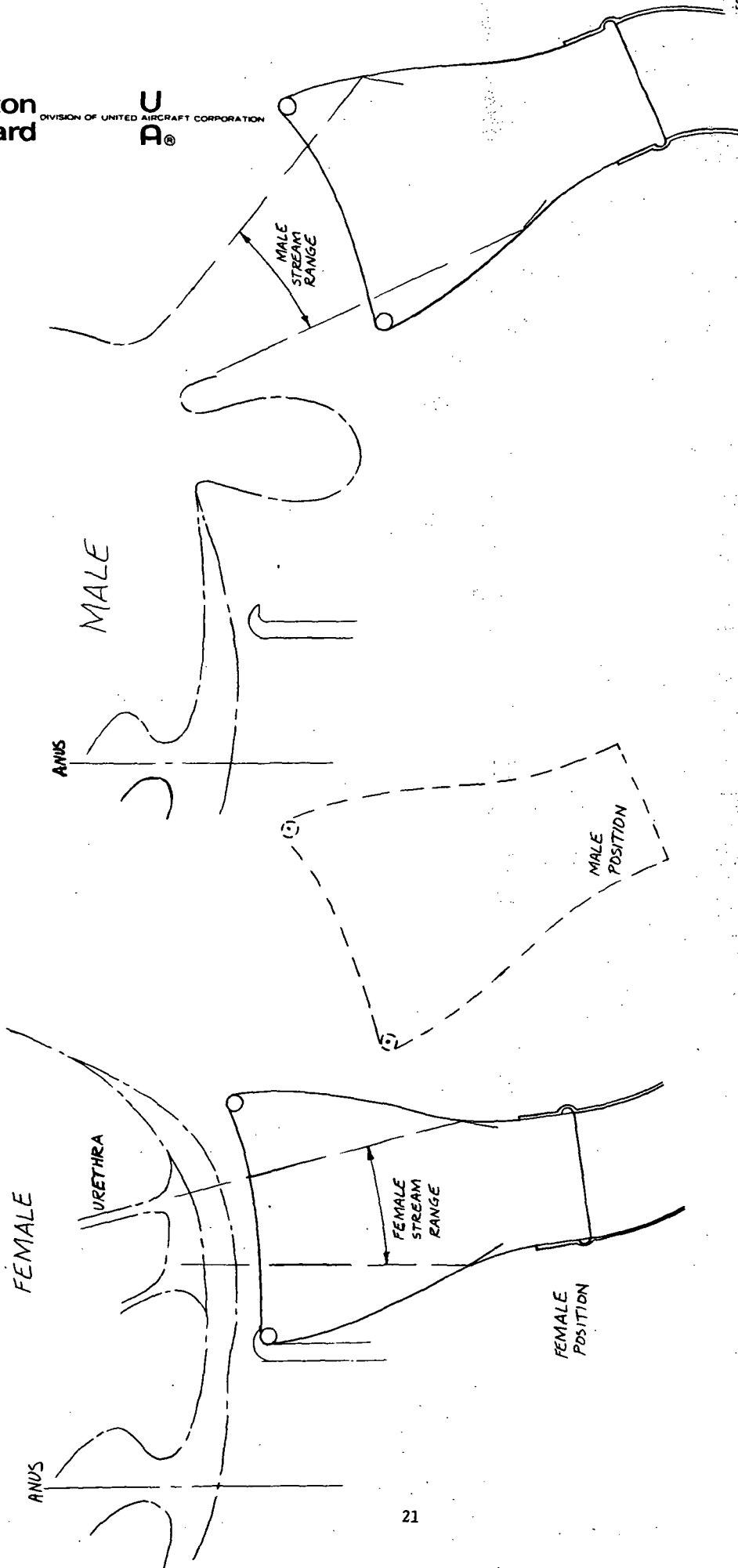

CONCEPT NO. 3 - TWO POSITION URINAL

FIGURE 9

Hamilton
Standard

DIVISION OF UNITED AIRCRAFT CORPORATION
U
A®

FEMALE F FLUSH POSITION

SVHSER 6182

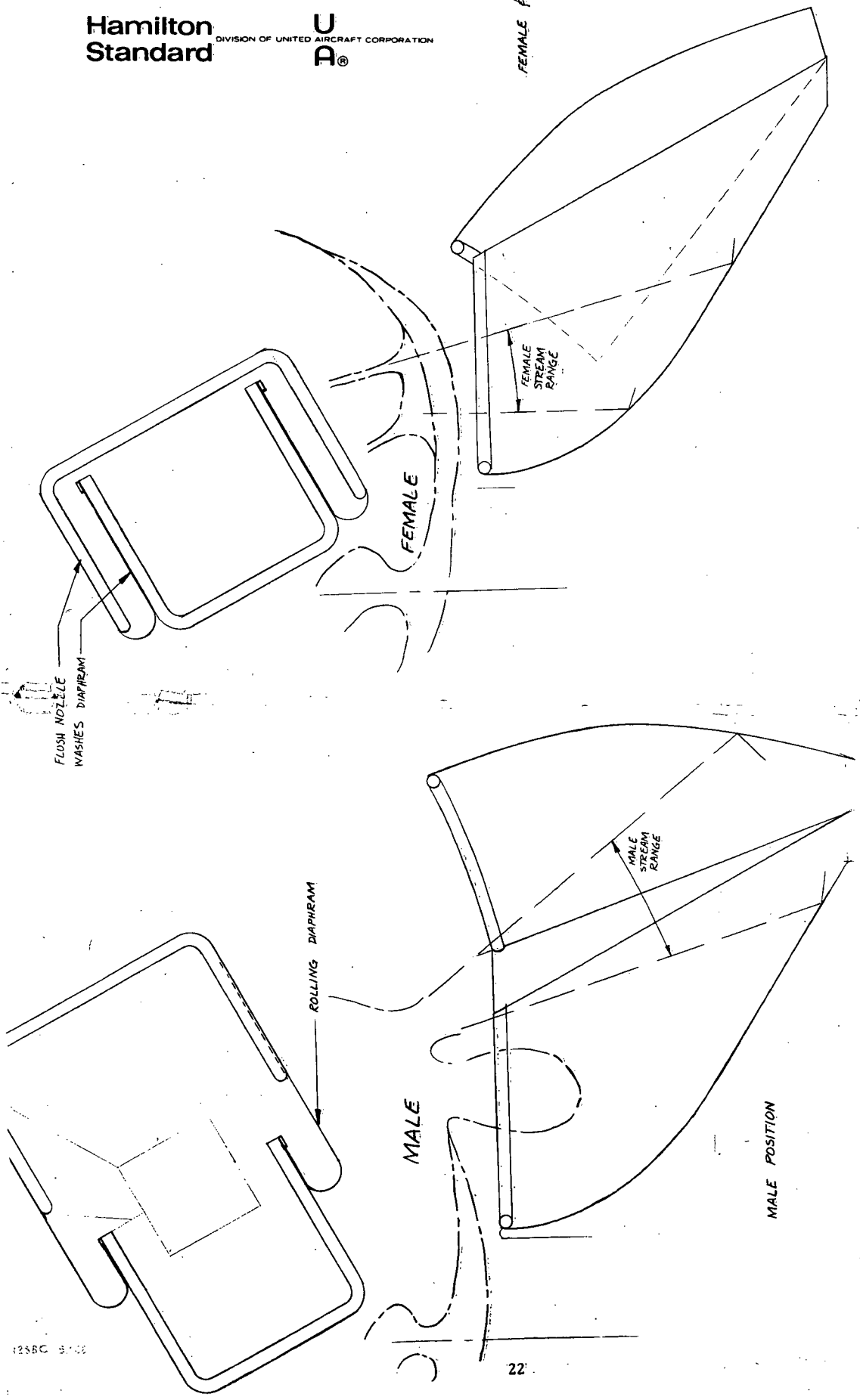

CONCEPT NO. 4 - VARIABLE AREA CONCEPT

FIGURE 10

transfer duct. For the male, the urinal moves forward and down so that it does not interfere with his testicles and penis. The male must be careful to direct his urine stream into the collector. The advantage of this collector is that it is small and requires less flow to maintain the required velocity profile. The urinal shape is simple and has no inherent stagnation areas.

Concept No. 4: The fourth concept is shown in figure 10. The general contour for splash containment is similar to those of Concepts No. 1 and No. 2. The primary feature of the concept is the clam shell construction that allows the urinal to fold up for female urine collection. In the folded position, flow is concentrated to provide the required velocity with a lower overall air flow. In the open or male position, this velocity is only provided in the male stream impact area near the outlet duct. The rolling diaphragms located on each side of the urinal are critical to the success of this concept.

Each of the four urinal concepts presents unique features. These features were evaluated by fabricating four urinal mockups for subjective evaluation. The results of this evaluation and the final selected urinal concept will be discussed under the Design Section of this report.

Seat Design Study

Objective

The objective of this study was to establish the proper commode seat design to be utilized with the Development Waste Collection Subsystem.

Summary of Results

The commode seat design must consider two major interfaces: the interface of the man on one side and the feces and urine collection equipment interface on the other side. Although the equipment interfaces depend only on the collection equipment, the human interface requirements also change with the gravity field. Combining the anatomical and hardware interface requirements establishes the seat configuration defined in figure 11.

The outside envelope of the seat resembles a conventional seat to approximate an earth-like appearance. The interface features are established by the location of the urinal divider and tuberosity supports. The tuberosity support seating approach is chosen over the conventional toilet seating approach because it best supports the body weight, easily adapts to the feces collection equipment and it allows postural changes without sacrificing collection effectiveness.

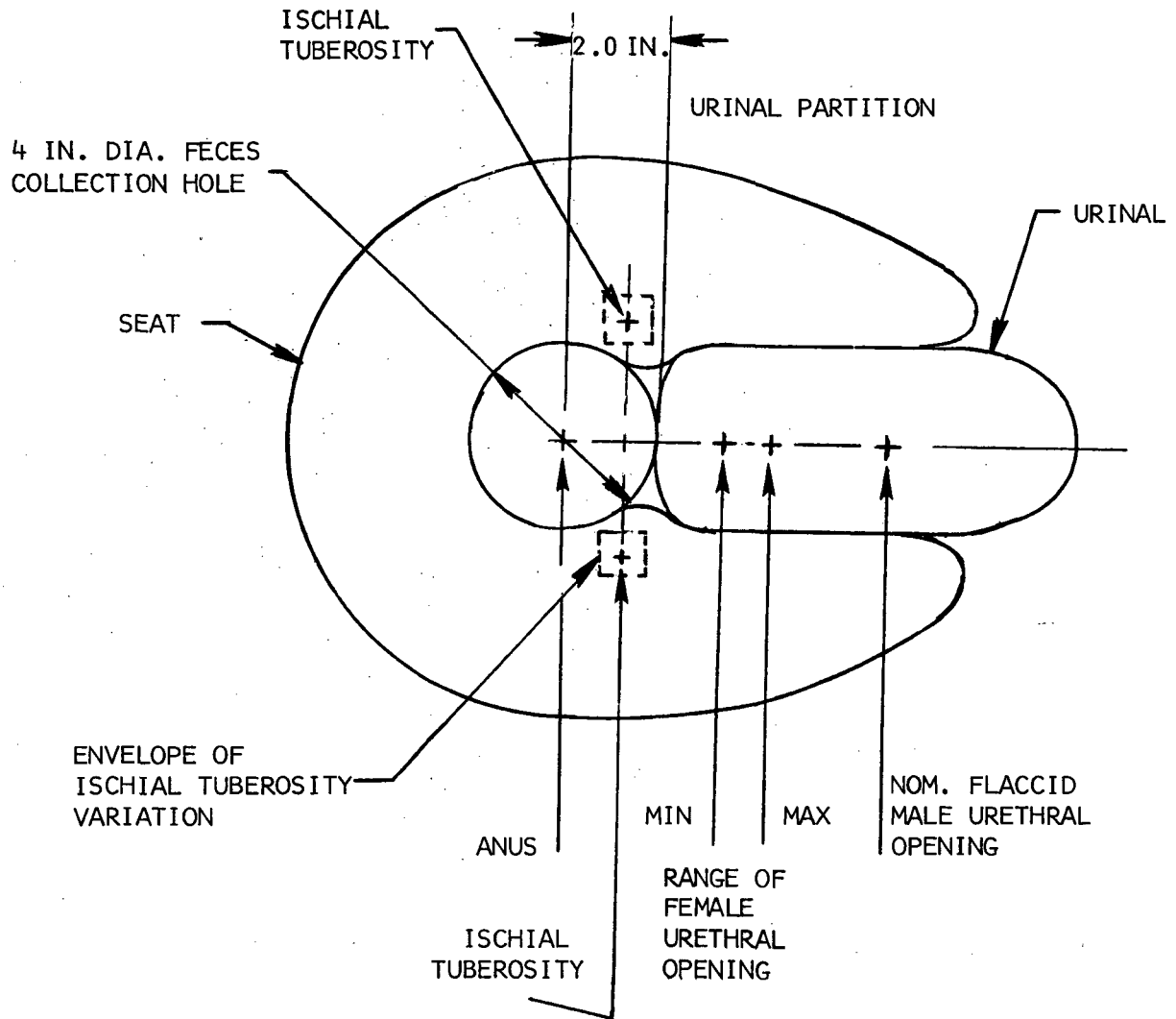

SEAT CONFIGURATION BASED ON
ANATOMICAL REQUIREMENTS

FIGURE 11

A four inch feces collection hole is chosen for several reasons. The front edge is established by the urinal divider, the back edge is compatible with the anus location on domestic toilet seats (2 to 2.5 inches from the back edge), and the sides are bounded by the tuberosity supports. Previous waste management testing conducted as part of the Space Station Prototype program⁽¹⁾ had verified that the four inch diameter hole is acceptable for feces collection. Further, a small hole better approximates optimum seating load distributions, reduces the complexity of the buttock seal configuration and allows the feces collection equipment to be simpler and more compact.

The contouring of the seat within the given envelope is based on both one and zero gravity considerations. A seat designed for use in one-g would be contoured to aid in buttocks spreading, distribute seating loads for comfortable use, and allow access for wiping. A seat designed for use in zero-g would be contoured to provide an effective buttock seal for proper feces collection and entrainment flows, and provide proper flow passages for urine collection and entrainment.

The Waste Collection Subsystem Development Unit will be used primarily in one-g but must have the capability for zero-g operation. As a result, the seat must be contoured for one-g support and also must be designed to minimize leakage for adequate zero-g operation. A seat designed to these criteria has the general contouring approach defined in figure 12.

Three concepts that meet the general contouring requirements of the seat are illustrated in figures 13, 14 and 15. The major differences in these concepts are the amount of access each allows for wiping. In the first concept, the seat is contoured for buttock spread and load distribution with no special allocation for wiping access. In the second concept, a channel is provided in the back of the seat for wiping access. In the third concept, the importance of wiping access is stressed resulting in little area for cheek spread and load distribution.

It was very difficult in the study to properly assess the trade that is involved in accommodating the possibly conflicting areas of buttock spreading versus wiping access. In order to define a final seat configuration, the general seat envelope and contouring approach defined by figures 11 and 12 were used in conjunction with the contours defined in figures 13, 14, and 15 to fabricate a number of seat mockups for subjective evaluation. The results of the evaluation and the selected seat design will be discussed in the Design Section of the report.

Post Elimination Cleansing Study

Objective

The objective of this study was to evaluate and select the best method of perineal and vulva cleansing to be utilized with the WCS.

⁽¹⁾ Passalacqua, J. Test Report Two Stage Waste Management System, HS report, SSP Document No. 63, Contract NAS 9-10273, 1970.

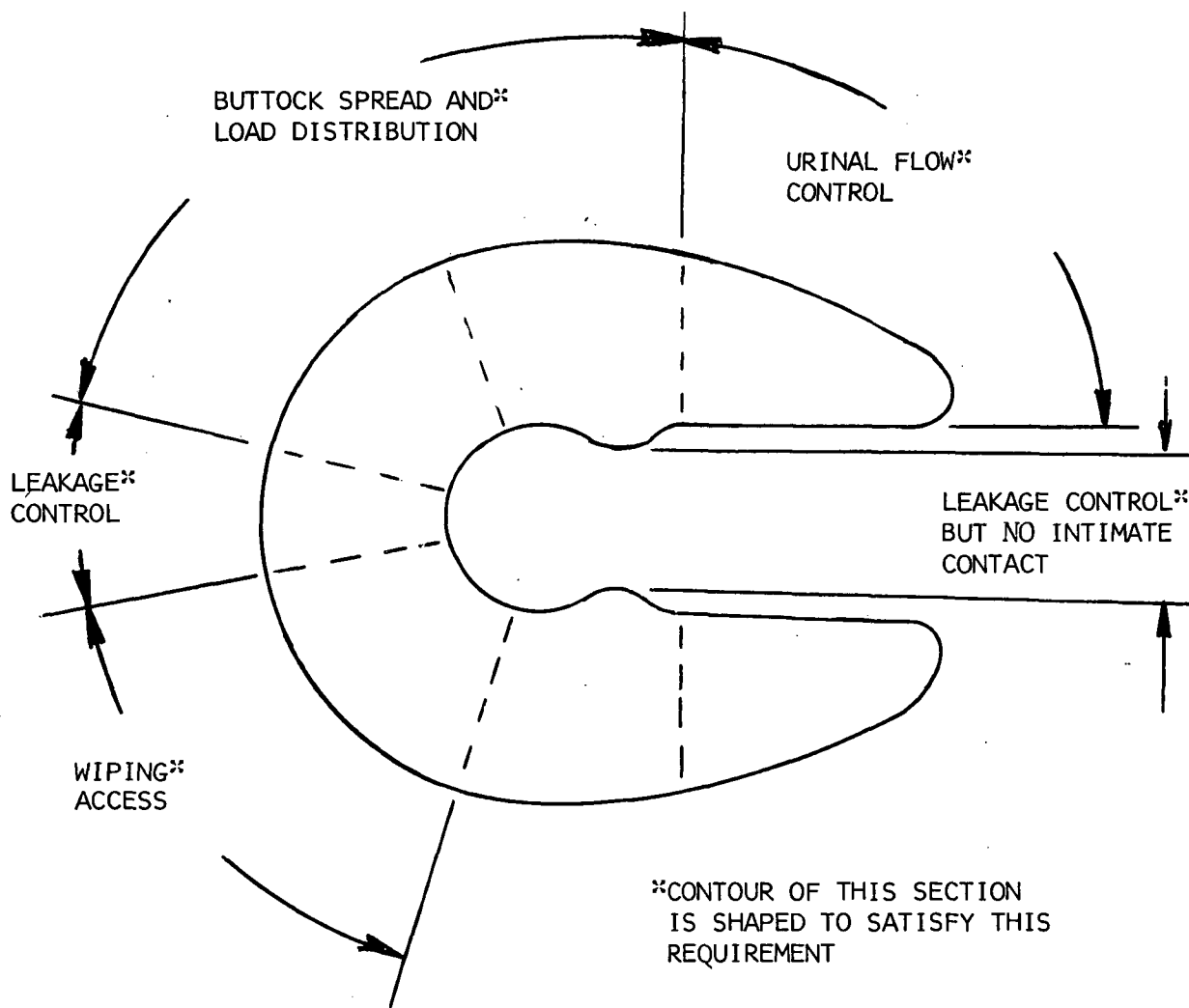

CONTOUR REQUIREMENTS FOR THE
TUBEROSITY SUPPORT SEAT

SVHSER 6182

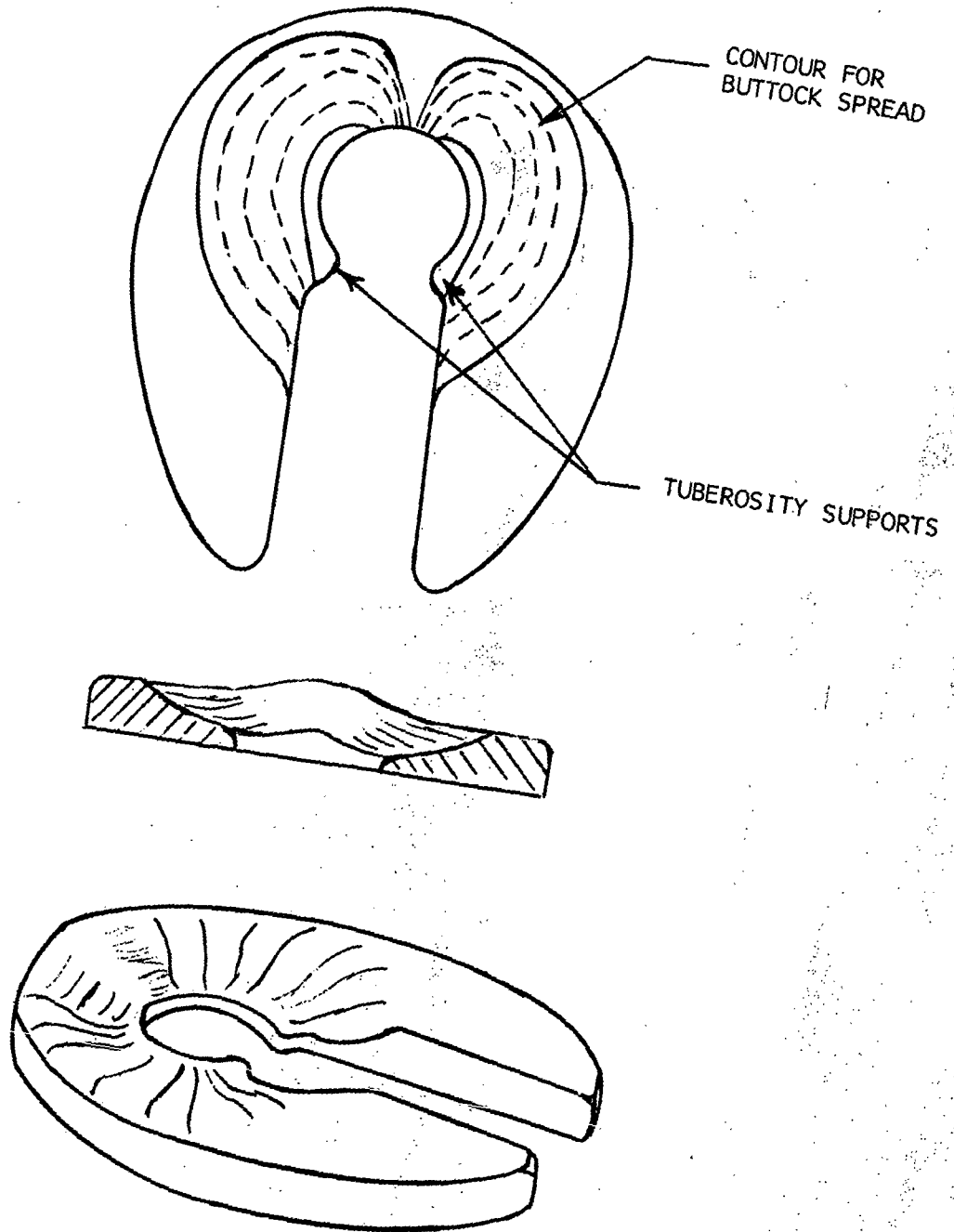

CONCEPT No. 1

FIGURE 13

27

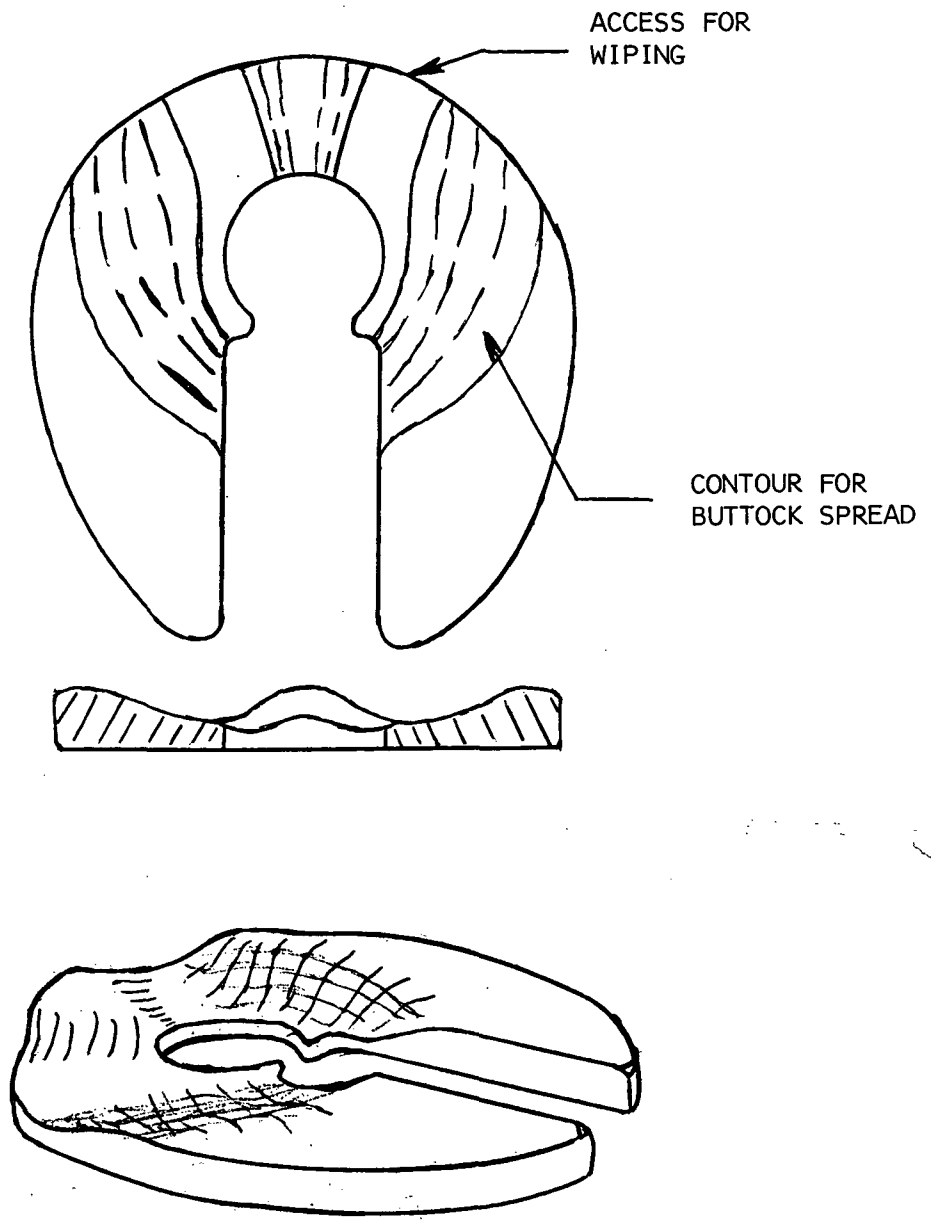

CONCEPT NO. 2

FIGURE 14

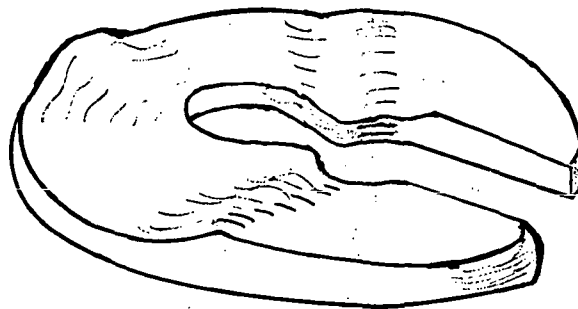
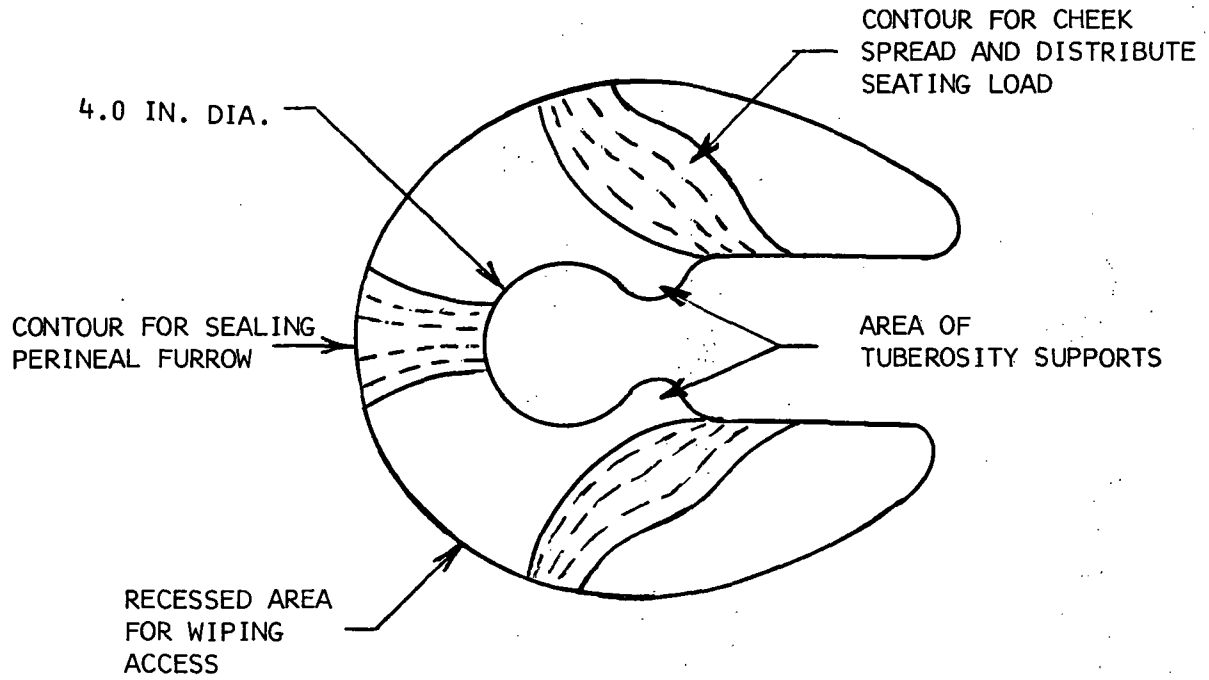

CONCEPT NO. 3

FIGURE 15

Summary of Results

The study shows that for the Shuttle orbiter vehicle, the best method of post-elimination cleansing is the use of wipes for both vulva and perineal cleansing. This selection is based on performance, expendables required, test results and subject acceptance due to the close relationship to terrestrial methods. It may be necessary to utilize a combination of wet and dry wipes for perineal cleansing because it may be necessary to wet the anus due to the drying action of the feces separation jets.

The basic requirement for any post-elimination cleansing method is to remove body waste product residuals to maintain a physiologically acceptable level of personal hygiene. Table I presents an evaluation of both perineal cleansing concepts, wipes and douche, from a qualitative standpoint. It can be seen by a review of Table I that the use of wipes, while not optimum in performance, is superior in other aspects. The anal douche concept, while offering the optimum in performance capability and hands-off operation, is not practically proven in a zero-g environment.

The use of a douche to provide cleansing of the vulva area of female crew members and the pubic-scrotal area of males was considered in the interest of study thoroughness. The use of such a device for a male is not considered practical because of the low contamination levels associated with male elimination as evidenced by the acceptable levels of personal hygiene maintained in a terrestrial environment by males without a cleansing method. Considering the female, it was found that the only effective douche would be a hand-held unit that would require manual spreading of the labial folds to gain effective cleansing. The net effect of a hand-held douche and manual spreading of the labial folds would undoubtedly create additional contaminated areas and could spread contamination to the cabin atmosphere. The vulva douche also would contain all the disadvantages listed for the perineal douche in Table I. Therefore, it is recommended that wipes be utilized for vulva cleansing of the female crew members.

No-Vent Requirement Study

Objective

The objective of this study was to determine the optimal method of feces storage and control for the WCS Development Unit if the requirement were imposed that neither gases nor liquids can be vented to space.

<u>Criteria</u>	<u>Advantages</u>	<u>Disadvantages</u>
I. <u>PERINEAL WIPES</u> (wet and dry combination)		
A. <u>Safety</u>		
Physical	- No mechanical, thermal, or electrical hazards are foreseen.	- Possible irritation of the skin due to excessive rubbing. - Possible chemical irritation due to variability of the constituents in the wet wipes.
Contamination Control	- Contamination of the cabin is lower than if the anal douche were used, provided that the optimum wetting factor is found for the wipe based upon its intended use and the wipes are not required to be transferred from the commode/processor to another collection and storage container.	
Microbial Control	- Wipes wetted with a bacteriostatic liquid could assure a more positive degree of control.	
B. <u>Performance</u> (functional)	- Rubbing the wipe against the perineal area is an effective way of removing the fecal smear and maintaining the normal skin microbial balance.	
C. <u>Development</u>		
Current Status	- Used on Apollo, presently flight qualified and fully operational.	
Future Development Required		- May require additional testing to prove acceptability of the bacteriostatic liquids and/or detergents for the longer missions in terms of maintaining normal skin microbial balance.
Possible Flight Date	- Available now because of its present flight status.	
D. <u>Crew Acceptability</u>	- Approach more closely duplicates the procedures used on earth than the douche concept, therefore, acceptance and confidence should be maximized and the required training and familiarization minimized.	- The individual preferences associated with the amount of paper in the wipe and the size of the wipe would have to be standardized, as well as the number of wipes available per occurrence.

PERINEAL CLEANSING STUDY MATRIX FOR WIPES VERSUS DOUCHE

TABLE I

<u>Criteria</u>	<u>Advantages</u>	<u>Disadvantages</u>
E. <u>Usability</u>	<ul style="list-style-type: none"> - Offers minimum preparation for reuse; requires only adequate dispenser sizing. - Maximum capacity of system available to handle diarrhetic defecations with a minimum of fixed and expendable weight added. - This system offers the best approach for a contingency or backup system to some other hygiene concept. 	
F. <u>Maintainability</u>	<ul style="list-style-type: none"> - Should be no maintenance, scheduled or unscheduled, because there are no functional parts associated with the dispensing, use, or collection of the wipes. 	<ul style="list-style-type: none"> - The size of the waste storage/disposal equipment will be increased due to additional bulk of the wipes.
G. <u>Complexity/Reliability</u>	<ul style="list-style-type: none"> - Minimum complexity and maximum reliability of the two perineal cleansing concepts. 	
H. <u>Spacecraft Interface</u>	<ul style="list-style-type: none"> - This approach has no dependent interfaces with other Space Shuttle subsystems. 	
I. <u>Vulnerability</u>	<ul style="list-style-type: none"> - This approach can operate independently of all other Space Shuttle subsystems. 	
II. <u>PERINEAL DOUCHE</u> (fixed and/or hand held units)		
A. <u>Safety</u>		
Physical	<ul style="list-style-type: none"> - No mechanical hazards are foreseen. 	<ul style="list-style-type: none"> - The possibility of personal hazards resulting from high pressure fluids as well as high and low temperature fluids exists. - The remote possibility of an electrical hazard associated with the douche/drying cycle does exist.
Contamination Control		<ul style="list-style-type: none"> - The probability of cabin contamination, specifically during the wash cycle, is the highest of either approach studied because of the man/seat sealing problems.

PERINEAL CLEANSING STUDY MATRIX FOR WIPES VERSUS DOUCHE

TABLE I (Continued)

<u>Criteria</u>	<u>Advantages</u>	<u>Disadvantages</u>
Microbial Control	- Positive control of organisms can be effected.	- Because of man/seat sealing problems and the expected "fluid splashing", extensive cleaning methods will be required. Cleaning of external surfaces in addition to the internal flush with a bacteriostatic liquid could be the approach to follow
B. <u>Performance</u> (functional)	- A properly administered douche in the perineal area is the most effective and thorough approach for cleaning and maintaining normal hygiene. - The addition of a detergent and bacteriostat to the douche water in combination with an air drying device represents the ultimate in "hands-off" waste collection and associated hygiene.	
C. <u>Development</u>		
Current Status	- This approach is in the preliminary design-concept stage, and efforts to date have included only 1-g feasibility testing.	
Future Development Required		- This approach requires detail redesign, development testing including zero-g evaluation and an extensive qualification test program.
Possible Flight Date		- Longer lead time of either approach because of its present prototype status.
D. <u>Crew Acceptability</u>	- After training and familiarization are completed, acceptance and confidence should approach that of the wipe system, but personal preference will probably continue to be negative.	- Based upon acceptance by the general population in this country, crew acceptance for Space Shuttle applications would be very low.

PERINEAL CLEANSING STUDY MATRIX FOR WIPES VERSUS DOUCHE

TABLE I (Continued)

<u>Criteria</u>	<u>Advantages</u>	<u>Disadvantages</u>
E. <u>Usability</u>		- Definite weight and volume penalties would be associated with providing storage on the Shuttle vehicle for the extra water utilized.
F. <u>Maintainability</u>		- This approach will require the greater amount of crew maintenance time ⁽¹⁾ because of the subsystems associated with washing and drying.
G. <u>Complexity/Reliability</u>		- This approach is the more complex of the two perineal cleansing systems and, therefore will have the higher reliability penalty associated with it.
H. <u>Spacecraft Interfaces</u>		- This approach has possible dependent interfaces with the following vehicle subsystems: <ul style="list-style-type: none"> ● Electric power ● Water supply, processing, and/or disposal ● Gas supply, processing, and/or disposal.
I. <u>Vulnerability</u>	- This system concept while having no inherent contingency mode does allow the WCS to be used with wipes as a contingency mode providing wipes are available.	

(1) Both scheduled and unscheduled.

PERINEAL CLEANSING STUDY MATRIX FOR WIPES VERSUS DOUCHE

TABLE I (Concluded)

Summary of Results

The WCS Development Unit utilizes vacuum drying, venting the fecal gases to space as the method of reducing fecal volume for storage and inhibiting microbial growth. Urine was not considered in this study since all that is necessary to meet a no-liquid dump requirement are accumulators or tanks capable of containing all the waste liquids. The concepts considered were limited in scope to a minimum departure from the basic vacuum-drying-vent-to-space concept to eliminate total redesign of the WCS.

The three concepts evaluated as modifications of the basic WCS were:

1. Vacuum Drying/Filtration.
2. Vacuum Drying/Catalysis.
3. Germicide/Storage.

Vacuum Drying/Filtration. - The vacuum drying/filtration concept requires the addition of a vacuum pump and a condenser/accumulator to the basic vent-to-space process. Following use of the WCS commode, air is pumped out through the odor/bacteria control canister reducing pressure in the commode. The air returns to the lavatory atmosphere. As commode pressure decreases below the vapor pressure of water, the fecal water evaporates rapidly. The resulting water vapor is pumped through the condenser/accumulator, which retains the condensate in a sponge or wick that has been pretreated with a germicide. Non-condensable gases are discharged to the odor/bacteria control canister where bacteria and toxic constituents are removed. The remaining gases, mostly nitrogen, then return to the lavatory atmosphere. The odor/bacteria control canister is part of the basic WCS, located in the air entrainment flow stream. Figure 16 shows the addition of the vacuum drying/filtration concept to the basic commode.

Vacuum Drying/Catalysis. - The vacuum drying/catalysis concept is basically the same as the vacuum drying/filtration concept except that the vent stream odor/bacteria control function is performed by a catalytic oxidizer that is also added to the system. An air stream (bled from the lavatory atmosphere) combines with the vent stream at the vacuum pump suction to provide oxygen for the oxidation reactions. After passing through the condenser/accumulator, which removes water vapor, the air-gas mixture is reacted over a palladium-on-alumina catalyst at 580°F. This destroys all bacteria and oxidizes hydrocarbon and carbon-hydrogen-oxygen contaminants to form carbon dioxide and water vapor. The vent stream would then be discharged to the cabin atmosphere without further treatment. The system utilizing a catalytic oxidizer is depicted in figure 17.

Germicide/Storage. - The germicide/storage concept is shown in figure 18; it eliminates the vacuum drying process altogether. Fecal water is retained with the fecal solids in the commode. Following defecation, a hand-operated

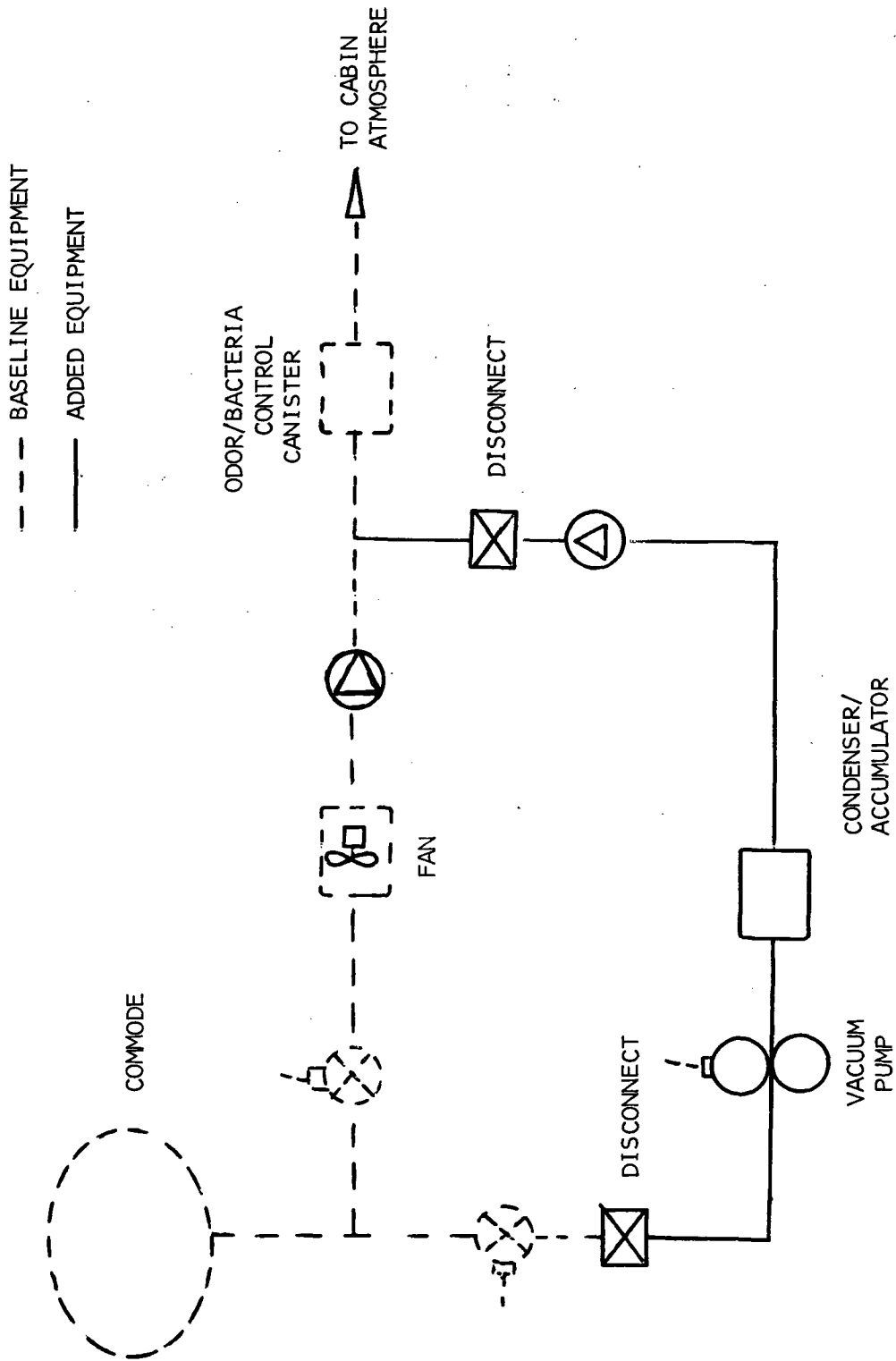

VACUUM DRYING/FILTRATION CONCEPT

FIGURE 16

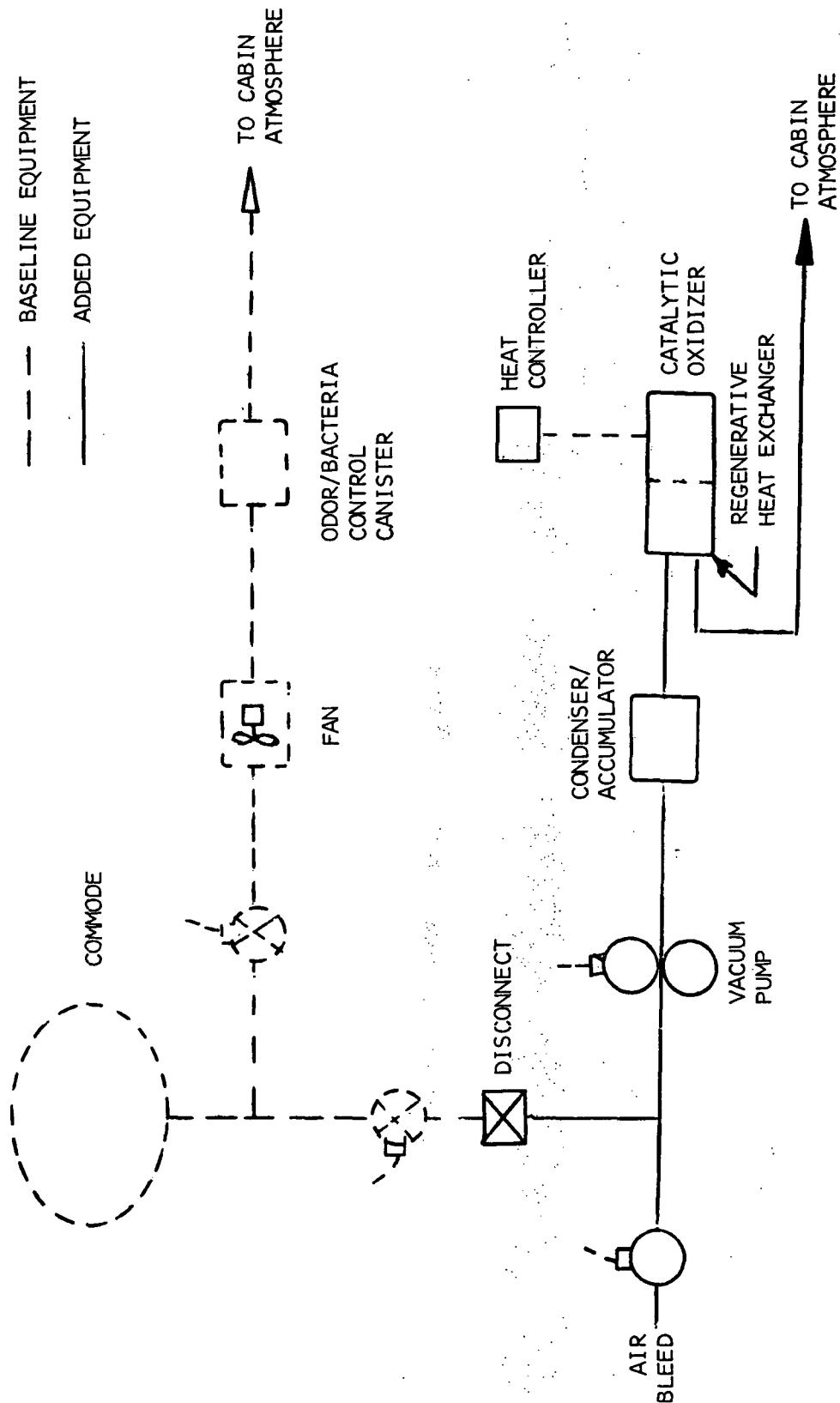

VACUUM DRYING/CATALYSIS CONCEPT

FIGURE 17

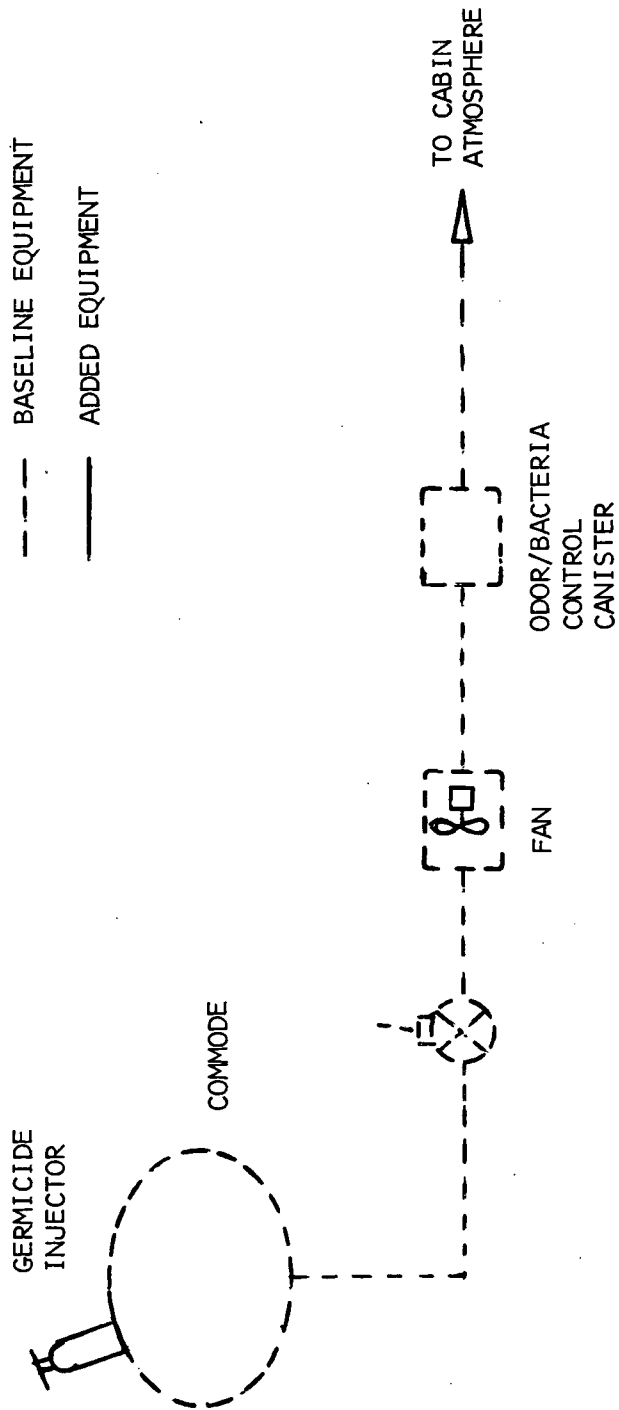

GERMICIDE/STORAGE CONCEPT

FIGURE 18

pump sprays the feces with a germicide (such as silver sulfate or a quaternary ammonium salt of copper) to maintain bacteriostatic condition. The commode design must be altered slightly to accommodate the pump and possibly to provide storage volume for the fecal water.

Two types of criteria were used to evaluate the candidate concepts. The first criterion was performance, the second type is a set of six criteria reflecting the relative attractiveness of the concept. These criteria were reliability, simplicity, weight, power, volume, and hardware compatibility. Table II summarizes the results of the evaluation.

	VACUUM DRYING/ FILTRATION	VACUUM DRYING/ CATALYSIS	GERMICIDE/STORAGE
PERFORMANCE	Very Good	Good	Fair
RELIABILITY	Good	Good	Very Good
SIMPLICITY	Good	Poor	Very Good
WEIGHT (pounds)	33.5	45.0	2.4
POWER (watts)	104	119	0
VOLUME (inch ³)	1056	1593	108
HARDWARE COMPATIBILITY (components added)	5	6	1

NO-VENT CONCEPT EVALUATION

TABLE II

The primary criterion utilized in the evaluation was performance. Performance indicates the probability that a concept will accomplish the desired task without problems. The desired task for the no-vent equipment is to maintain collected feces in the WCS commode in a bacteriostatic condition without venting to space vacuum. Potential problems are failure to accomplish this task and also contamination of the vehicle atmosphere.

Performance of the vacuum drying/filtration concept is expected to be very good. Drying is a proven method of stopping bacterial growth and eliminating fecal odors. (1) As mentioned earlier, the air stream odor/bacteria control

(1) Rogatine, L. N.: "Search for Preparations for Preservation of Feces for Use Under Space Flight Conditions"; in "Problems of Space Biology", NASA TT F-529, NASA; May 1969.

canister should be able to handle the additional load of the vacuum pump exhaust stream without problems. Vacuum pump development is the major equipment problem because of the difficulty of pumping water vapor without the use of a cold trap. However, the feasibility of designing such a pump has been established by the SSP program (NASA JSC Contract NAS 9-10273).

The vacuum drying/catalysis concept has the same vacuum pump development requirements as the vacuum drying/filtration concept. In fact, the high pressure drop of a catalytic oxidizer may add to the difficulty of designing for the air pumpout phase. The concept is extremely effective in eliminating micro-organisms from the exhaust stream. Catalysis also removes some gases, such as methane, which cannot be eliminated by sorption techniques. On the other hand, some gases that are both toxic and odorous will be converted to equally noxious contaminants. An example is hydrogen sulfide, a constituent of flatus, which is oxidized to sulfur dioxide. Other gases such as oxides of nitrogen⁽¹⁾ will not be removed. Thus development of the vacuum drying/catalysis concept will require supplementary sorption equipment.

The germicide/storage concept avoids the need to clean up a vacuum pump exhaust stream. However, the ability of a sprayed bactericide to maintain the fecal accumulation in a bacteriostatic condition is questionable. Furthermore, although odors are reduced they are not eliminated. The feces resulting from each defecation are spread in a layer on the walls of the commode. Some of the fecal matter may be deposited in lumps that are not penetrated by the atmosphere despite use of the air stream. In addition, the danger of bacteria migrating to the commode seat would be increased. Another problem of incorporating a germicide/storage concept into the commode is that a liquid germicide will decrease the viscosity of the feces. As the feces/germicide mixture becomes less viscous the action of the slinger and entrainment air flow could agitate the mixture causing the air flow to entrain and carry bits of fecal matter and moisture out of the commode. Entrainment of the fecal matter in the air stream might eventually cause overloading of the odor/bacteria control canister. Further work is needed to determine whether these hazards occur.

It should be emphasized that the germicide/storage concept described herein represents a modification of the baseline vacuum drying commode of the WCS. A version designed to assure performance would be more complex and would require a commode design of larger volume to accommodate a feces/liquid germicide mixture and also incorporating additional equipment to mix the contents into the homogenous slurry necessary to inhibit microbial growth.

It was concluded that although the germicide/storage system proves to be a very attractive concept, performance (inhibiting microbial growth) could not be guaranteed without creating a fecal slurry, which would have required significant modifications to the basic WCS concept. Therefore, the vacuum drying/filtration concept was chosen for this application. This concept as described previously is in reality a modified vacuum-drying concept creating its own vacuum.

(1) Kustov, V. V., and others: "Toxic Gaseous Substances Liberated from Human Feces During Storage"; in Problems of Space Biology", NASA TT F-529; NASA; May 1969.

Vomitus Collection Study

Objective

The objective of this study was to synthesize and evaluate candidate systems for the collection of vomitus from crewmembers, select a viable configuration for use and determine any effect on the WCS resulting from the selected configuration.

Summary of Results

In approaching the personal hygiene design requirements for an orbiting space vehicle, the very real possibility of gastric-distress from any number of causes and the resulting discharge of vomitus must be considered. This waste collection function, like the associated responses, must be considered an acute condition and treated as a true collection emergency. Provisions for the collection of vomitus must be available in all habitable areas of the vehicle. Furthermore, to be effective in collecting the waste discharged and to eliminate possible contamination of the cabin, the device must be accessible for use in less than thirty seconds.

The specific hardware concepts evaluated were:

- 1) Intimate personal adapter, integrated with WCS.
- 2) Intimate personal adapter, disposable.
- 3) Reusable portable collector, i.e., canister.
- 4) Disposable portable collector, i.e., bag.

The selected concept is the disposable portable collector (bag) depicted in figure 19, similar to that used on aircraft and on the Apollo flights. This unit can be carried by each crewman in the garment pocket and could be available for use in a minimum of time. The device is easily sized to enclose the entire oral-nasal area, and a good man-equipment seal can be effected with a minimum of personnel effort and training. This device makes maximum use of the material expulsion forces of the alimentary canal in both collecting and controlling the vomitus once expulsion has been initiated.

The disposable bag concept also represents the safest means of collection from the standpoint of personnel hazards. Due to the violent, possibly uncontrolled, body maneuvers associated with this waste discharge, concepts using rigid or semi-rigid structures are considered dangerous. After use, the bag and contents will be discarded into the feces collection subsystem, which incorporates a slinger-shredder designed to handle the bag.

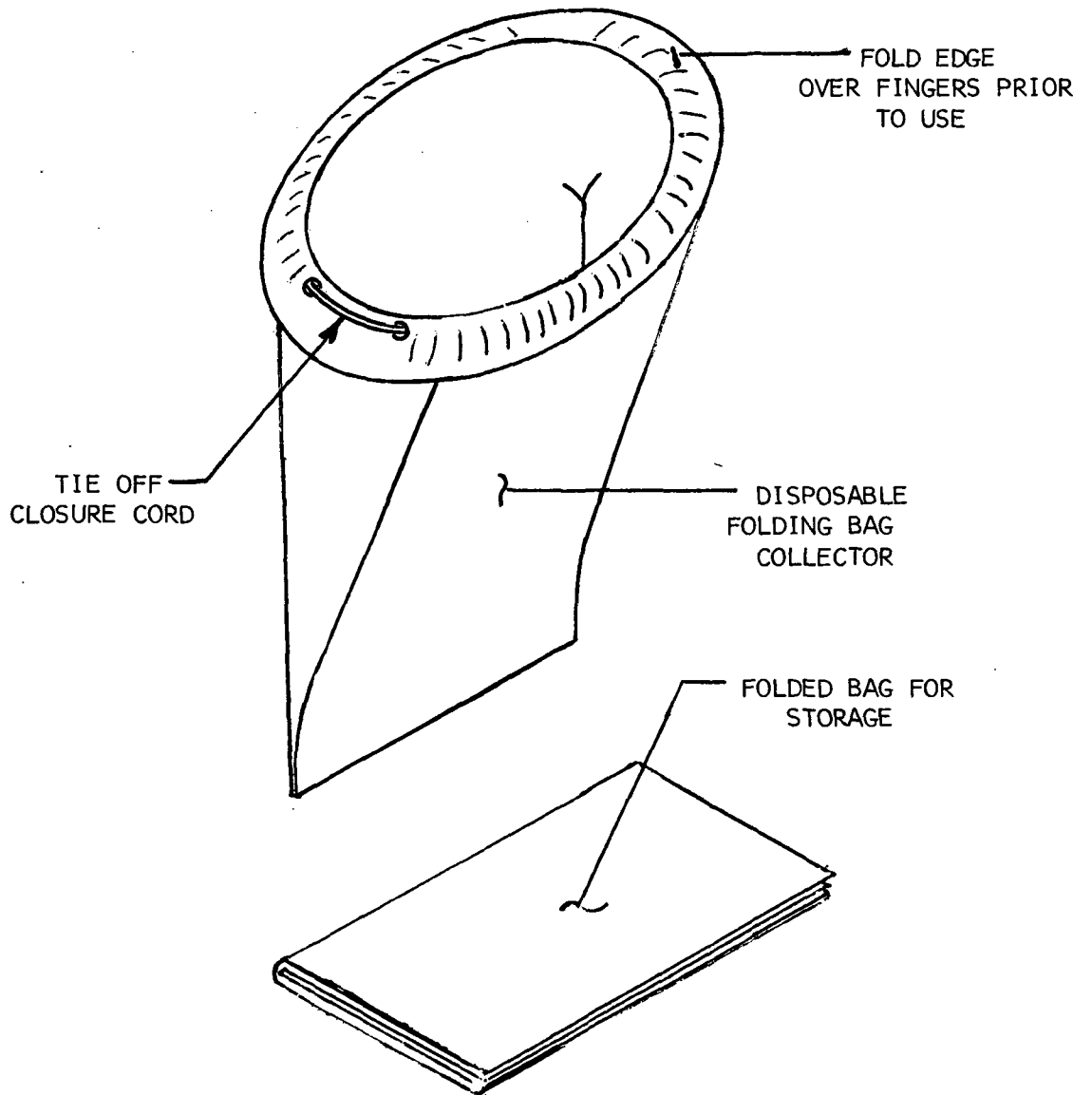

VOMITUS COLLECTION
PORTABLE DISPOSABLE COLLECTOR (BAG)

Test subjects have utilized this concept in zero-gravity test flights and were successful in effectively collecting vomitus.

Waste Sampling Study

Objective

The objective of this study was to evaluate and determine waste product sampling requirements for the Shuttle vehicle and other space applications. In addition, concepts for waste sample collection were synthesized.

Summary of Results

The basis upon which the specific biological waste products (i.e., urine and feces) sampling requirements for all future manned space vehicles will be established can be summarized in terms of the crewman's health care needs. The associated sampling classifications are as follows:

Routine Health Screening. - This will involve all crewmembers on-board the spacecraft on a regularly scheduled basis; the sampling frequency will be based upon existing terrestrial trend analysis techniques for healthy individuals.

Diagnostic/Clinical Support. - This will involve any crewmember on-board the spacecraft on an as required basis; the need will be established by the occurrence of an acute medical condition and/or a deviation from the norm during routine health screening. The type and frequency of sampling would be dependent upon the nature of the medical problem.

Medical Experimentation. - This will involve only a selected statistically valid group of test "subject experimenters" on-board the spacecraft on a continuous test regimen basis. The sampling frequency will be determined primarily by the test protocol; however, continuing twenty-four hour pools of each individual's waste products, with adequate samples as needed for analysis should be anticipated.

Ideally, these considerations are applicable to all manned spacecraft mission profiles, without regard to mission plan, duration, and crew size. From a practical standpoint, however, the hardware and crew time penalties associated with sampling equipment, as well as the vast quantity of cumulative data from preceding flights where a specific sampling protocol was accomplished, must be considered in establishing progressively more realistic

sampling requirements for future missions. This is particularly true of the Space Shuttle baseline missions, which presently do not exceed thirty calendar days or forty-two man-days, and which will have been preceded by the Skylab flight(s), involving three crews, of three men for up to fifty-six days. The sampling profiles for the Skylab crewmembers that provide for collection and sampling of all waste products should alleviate the necessity to sample waste on Shuttle flights either for health screening or medical experimentation. A pre- and post-flight sampling procedure similar to that utilized for the Apollo crewmembers will provide adequate data for routine health screening. It therefore is recommended that specific waste products sampling hardware not be included in the nominal on-board waste collection subsystem, and that a pre-flight/post-flight sampling protocol be established to assess the physiological responses of the Shuttle crewmen for the various missions. If extended Shuttle missions were proposed which could involve medical or paramedical experimentation, it is recommended that consideration be given to the use of a separate facility or equipment not part of the nominal on-board waste collection subsystem to accomplish the required sampling protocol.

Waste Products Sampling Concepts

Three waste product sampling concepts which could be utilized for long term space missions or for medical experimentation during short term flights were synthesized and are described herein.

Concept 1. - This concept (figure 20) is based upon the cartridge replaceable-maintainable components developed by Hamilton Standard as an IR&D effort. It consists of four principle components: a sample isolation/transporter canister; a sample collector module configured to handle a specific waste material; a dummy transport duct cross section for the non-sampling mode; and an isolation/receiver compartment for the dummy section during sampling modes.

The assembly essentially works as follows. A sample isolation/transporter canister with collector module installed is mounted to an appropriate interface fixture on the outside of the nominal transport duct. The sample collector module is then pushed out of the canister into the transport duct and at the same time displaces the dummy section into an isolation/receiver compartment. After the waste elimination function has been completed, the units are pushed in the reverse direction, placing the sample in a sealed transporter canister, and placing the nominal waste collection system on line.

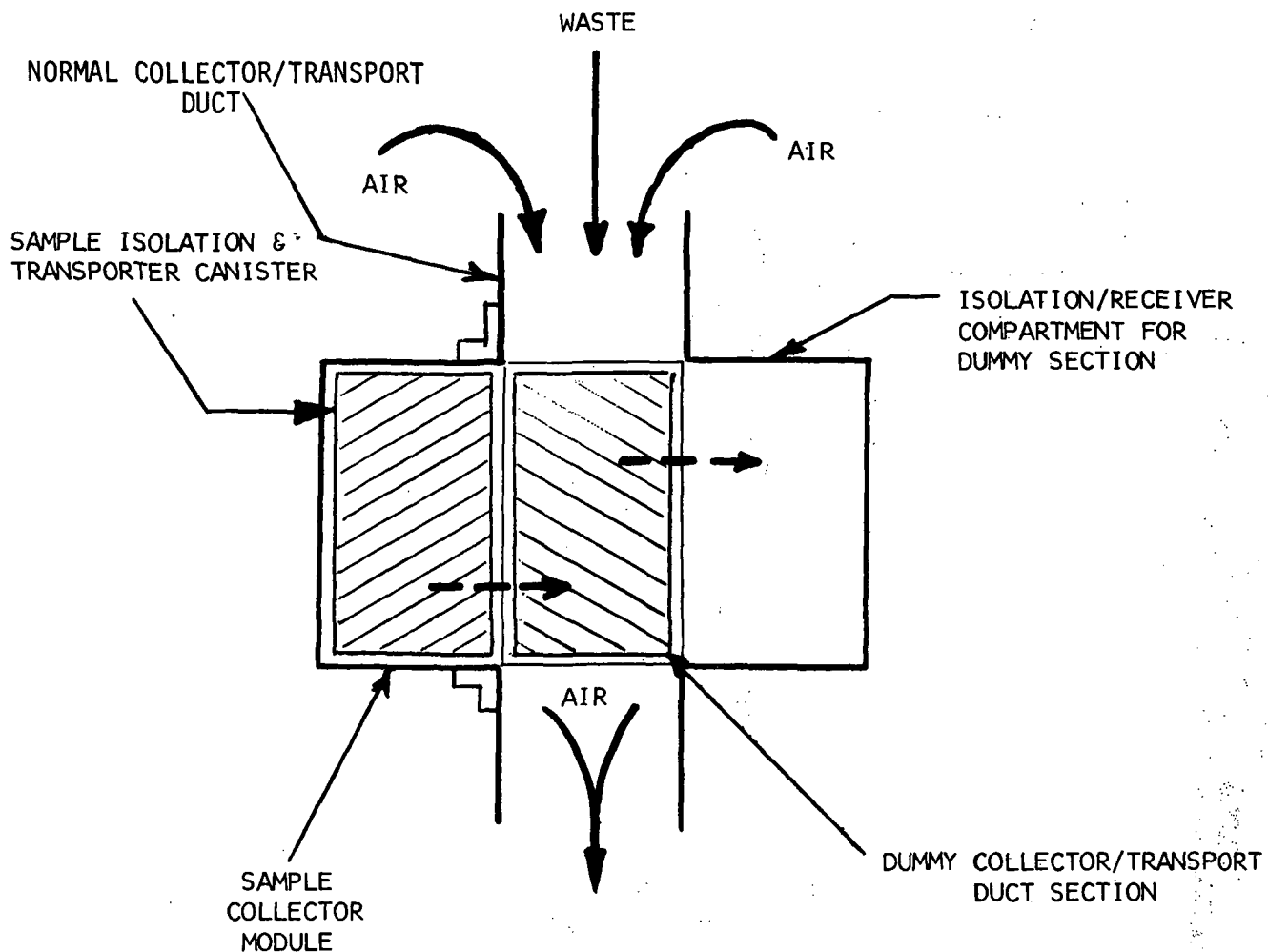

NOTE: SKETCH SHOWS NOMINAL WASTE CONFIGURATION; ARROWS SHOW RELATIVE POSITION CHANGES OF THE CANISTER REQUIRED TO SAMPLE WASTES.

SAMPLING CONCEPT NO. 1

FIGURE 20

Concept 2. - This concept, (figure 21), consists of disposable bags which are manually positioned within the nominal waste collection ducts, when a total void or defecation sample is required. The bags would have hydrophobic panels to pass the entrainment air flow and minimize the loss of fluids. The sampling units would be sealed after use by a mechanical closure (i.e., draw string, heat knife, etc.). Contaminant containment could be accomplished by the normal air entrainment flow, or if necessary, possibly by positioning jets directed into the fecal bag. This concept could be classified as a partially manual system.

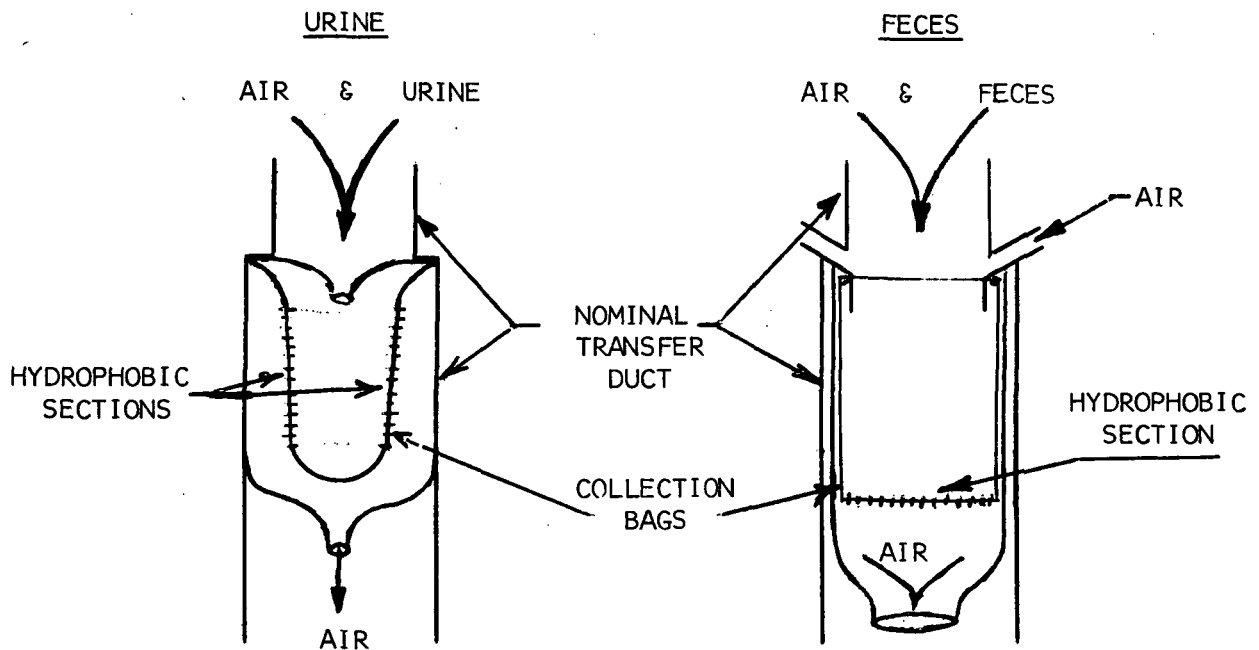

SAMPLING CONCEPT NO. 2

FIGURE 21

Concept 3. - This concept (figure 22) is manually operated and similar to the contingency bag proposed for "Skylab". For liquid waste sampling a handheld evacuated container, made of either disposable plastic or a reusable material is used. The container incorporates a one way flapper valve in the inlet to contain the fluid. In conjunction with this concept, fecal collection could be accomplished by use of the Apollo type hand-held fecal collection bag.

The urine collection bag has been utilized by a Hamilton Standard test subject in zero "g" aircraft flights and was effective in collecting a urine sample with no contamination of the test subject or the atmosphere.

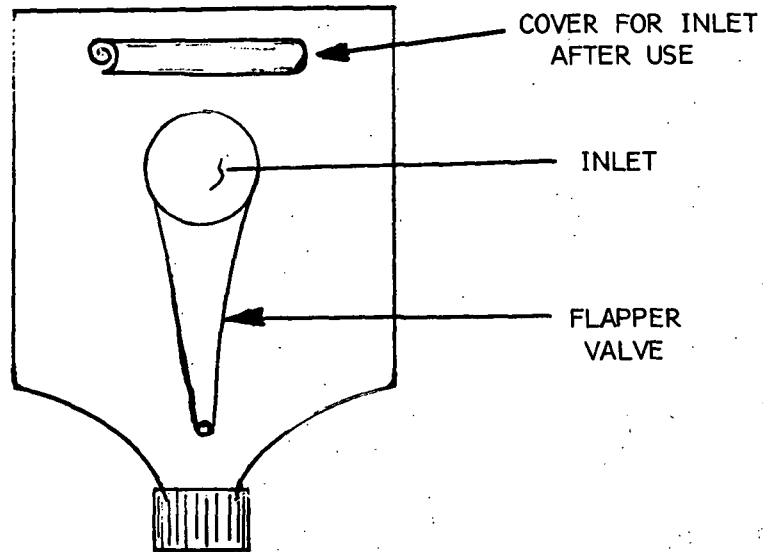

SAMPLING CONCEPT NO. 3

FIGURE 22

Fail Operational-Fail Safe Design Study

Objective

The objective of this study was to define a flight waste collection sub-system which would incorporate features needed to meet a projected fail operational-fail safe requirement for Shuttle vehicle life support equipment.

Summary of Results

In a system which incorporates a fail operational-fail safe design the following capability should be present. Fail operational capability denotes no degradation of a mission critical function following a hardware failure.

Fail safe capability denotes a condition following a hardware failure that permits mission abort without compromising crew safety. Waste collection is a critical function essential for mission completion and, therefore, should meet this general criterion to the degree practical.

A schematic of a flight WCS is shown in figure 25. (Note: this is a preliminary Shuttle WCS schematic generated in 1971 and has not been updated to current Shuttle requirements.) This schematic differentiates equipment required for normal operation and that needed to fulfill redundancy requirements. Table III summarizes the redundancy techniques to be utilized for the various components. A back-up technique is utilized to meet the overall requirement. This technique is a manual transfer approach similar to that used in Apollo and planned for Skylab use.

The back-up technique for waste collection uses gas-permeable or hydrophobic bags or containers. The collectors are designed for temporary attachment to the commode seat, as in the Skylab design, or they may be handheld as in the Apollo flights. After a feces container is filled it is sealed and manually transferred to the commode. Depending on the type of malfunction the fecal waste may be vacuum dried in the container or just stored. If vacuum drying is not feasible, it may be necessary to manually inject and mix germicide with the feces prior to storage in the commode. This approach assumes there will always be access to the commode. The only single failure that could possibly preclude access is a malfunction of the gate valve in the closed position, which is highly improbable. Therefore, the associated loss in reliability is acceptable. Urine is collected in auxiliary containers, which are then sealed and stored in convenient areas.

A significant question is whether this back-up technique represents a fail operational or merely a fail safe condition. The technique tends toward fail safe in that it is degraded by comparison with the primary WCS. However, the back-up technique may be used without preventing mission completion thereby making the primary waste collection equipment in a sense non-critical. The back-up technique, therefore, is recommended for consideration with the redundant equipment shown in figure 23 as the optimal method of insuring mission success for a flight waste management system.

Maintainability Study

Objective

The objective of this study was to generate and evaluate design concepts that could be incorporated into a flight version Waste Collection Subsystem to allow simple and quick ground maintenance. The general requirement for the study was that no hardware would require removal from the vehicle for routine maintenance.

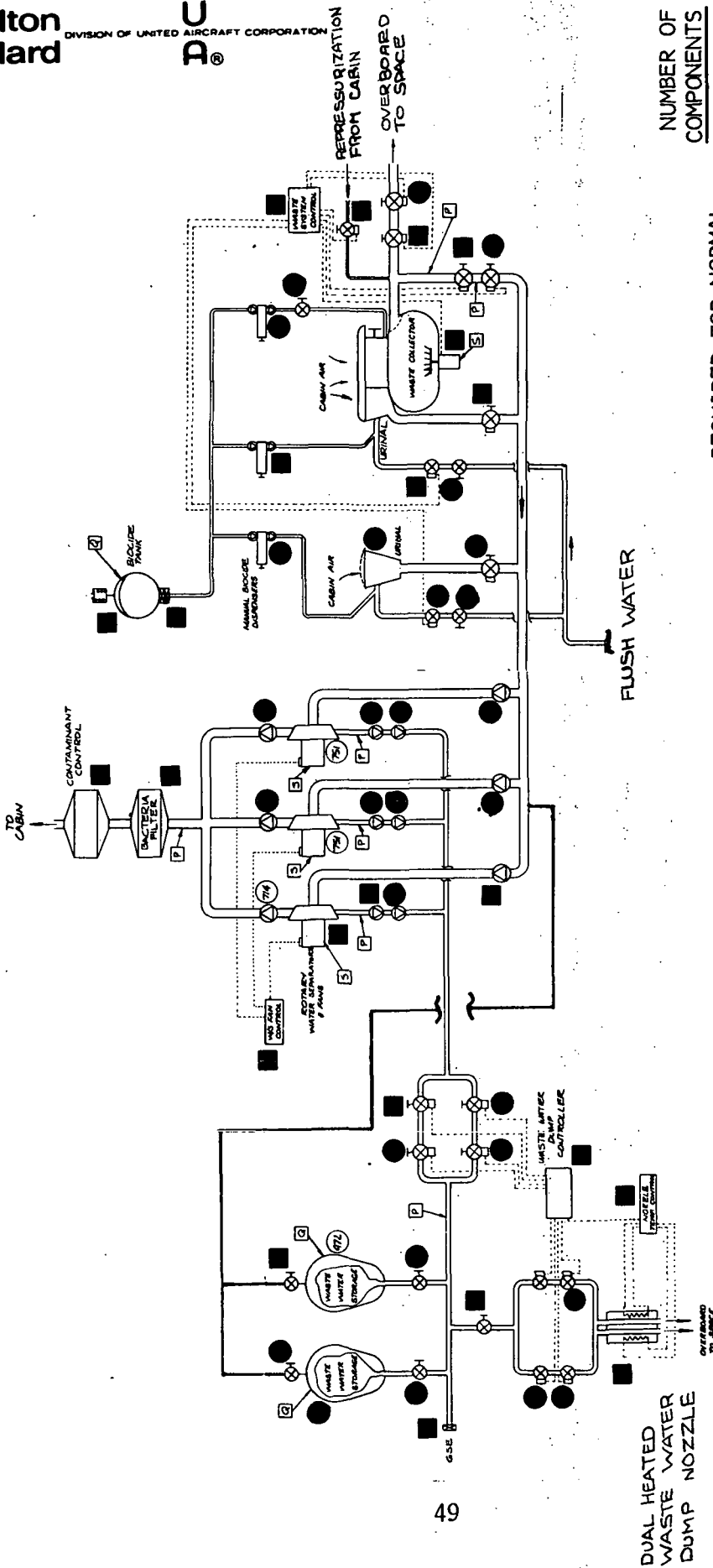

**NUMBER OF
COMPONENTS**

- REQUIRED FOR NORMAL OPERATION
- REQUIRED FOR REDUNDANCY

23

29

SVHSER 6182

INTEGRATED VACUUM DRYING PROCESS FLIGHT SYSTEM SCHEMATIC
FOR FAIL OP - FAIL SAFE REQUIREMENTS

FIGURE 23

Component	Fail Operational Back-up	Fail Safe Back-up
Commode	Back-up technique ⁽¹⁾	Back-up technique
Repressurization valve	Manual actuation	Back-up technique
Commode vacuum valve	Redundant valve	Manual operation or back-up technique
Commode airflow valves	Redundant valve	Manual operation or back-up technique
Waste system controller	Redundant circuit	Manual operation or back-up technique
Urinal airflow valves	Manual actuation	Alternate urinal ⁽²⁾
Urinal flush valves	Manual valves	Omit flushing
Standup urinal	Alternate urinal	Back-up technique
Bactericide dispensers	Use alternate urinal	Omit bactericide
Fan-separators	Redundant unit	Redundant unit
Bacteria filter	Static-not required	Back-up technique
Bactericide tank or valves	Omit bactericide	Omit bactericide
Contaminant filter	Static-not required	Back-up technique
Isolation valves	Redundant valve	Redundant valve or manual actuation
Waste water dump controller	Redundant circuit	Manual operation
Waste water vacuum valves	Redundant valve	Redundant valve or back-up technique

(1) Back-up technique refers to containers; urine is stored, feces are manually transferred to commode.

(2) Stand-up urinal for male personnel only, females must use back-up technique.

FAIL OPERATIONAL - FAIL SAFE FEATURES

TABLE III

Summary of Results

The present design criteria for Shuttle orbiter flight hardware dictate that equipment should be capable of meeting fail operational/fail safe requirements. Due to the design stringency and redundant components utilized in flight design concepts to meet this requirement the need for on-board maintenance is virtually eliminated. Therefore, for subsystems like the waste collection equipment the primary maintenance consideration is ground maintenance.

Maintenance tasks are generally divided into two types: scheduled and unscheduled. Scheduled maintenance is performed after every flight and consists of removing and replacing expendables, cleaning and in the case of the waste collection equipment, sterilizing the subsystem for between flight storage and finally the general pre-flight checkout. Unscheduled maintenance consists of removing and replacing components that either have failed or shown degradation in performance during the previous flight. The area of unscheduled maintenance is accommodated by using the proper design criteria for the components and also by making careful provisions to permit cleaning of the equipment even if failures occur.

In the scheduled maintenance area the waste collection equipment presents some unique maintenance requirements because of the contaminated contents contained within the equipment. Because of this, any equipment replacement or routine mechanical maintenance should not be attempted prior to removing the vacuum dried fecal matter and the urine, and completely sterilizing the system. The most obvious maintenance approach is to change the entire commode after each flight. However, this approach merely transfers the problem to a location outside the vehicle. Even though this approach minimizes the contamination potential in the vehicle, it requires a much longer total maintenance time because the container has to be removed and replaced in addition to being emptied. The removal of the entire commode was not considered for this study, which concerned itself solely with in-place maintenance.

The study revealed that the most feasible approach for cleaning the commode is to dissolve the freeze-dried fecal matter and wipes into a slurry and pump it out of the vehicle. Since the feces are broken up by the slinger/shredder prior to vacuum drying, they dissolve into a slurry. The slurry could then be pumped out of the vehicle through a built-in flush system. The urine would be pumped out of the urine tanks in the same general manner.

Three concepts for dissolving the fecal wastes were evaluated:

Mechanical. - the feces are mechanically dislodged and agitated in a water solution.

Hot Water Spray. - hot water is sprayed through high pressure nozzles. The pressure is used to dislodge feces and agitate the solution.

Steam. - High pressure steam is introduced through nozzles to dislodge the feces. Water must then be added to dissolve the loosened matter.

The hot water spray approach is chosen as the most promising for development. This choice evolved from considering the Aerospace Ground Equipment (AGE) requirements, simplicity, maintenance time required and the potential for vehicle contamination.

Once the contents of the feces collector and the urine storage tanks have been emptied, the entire subsystem has to be sterilized for between flight storage and preparation for the next flight. Two concepts are applicable for this purpose: steam purging and liquid flushing with a disinfectant solution. Evaluation of the concepts on the basis of simplicity, reliability, maintenance time and vehicle contamination potential shows that liquid flushing with a disinfectant solution, (Vancide BN is a good candidate for this application), is the best approach for the Shuttle application.

The choice of liquid flushing with a disinfectant solution has an impact on the system and component designs. This impact is categorized by the following components.

Filters. - The charcoal and bacteria filters in the air outlet line are expendables that are replaced after every flight. By removing them prior to system flushing, a convenient AGE connection is provided at one system outlet.

Valves. - All valves, except check valves, should have manual overrides so that even failed valves can be flushed prior to other maintenance tasks on the WCS. This requirement does not apply to check valves because it would severely hinder their design, especially when considering that they rarely fail in a closed position.

Tanks. - The waste fluid tanks will have to have two connections, an inlet and outlet, separated by an internal baffle. This is needed to generate a flow-through flushing action in the tank. With only one connection, stagnation points occur and effective flushing cannot be assured.

Urine Separator/Fan/Pump. - This component could be operated for a self-cleaning approach, but this only cleans the liquid section. A total flooding approach is recommended, where the disinfectant solution is introduced through

the inlet, and both the air and urine outlets are back-pressured to control the flushing action inside the unit.

Urinals. - Since the urinals are the initial components in the liquid portion of the WCS and are also exposed to the cabin, they are the natural inlet interface with the AGE. For introduction of the flushing solutions AGE connections will be fabricated that interface with the top of the urinals. The exposed urinal surfaces should also be manually scrubbed to remove any contamination not removed by flushing. This is needed to assure a clean interface with the flight crew.

Commode. - The feces collector is flushed with the same built-in nozzles that are used to generate the slurry for cleaning the commode. After the slurry is pumped off, a disinfectant flush is used to sterilize the commode; the flush is carried away by the slurry drain ports. The seat and flow manifold are cleaned by manual scrubbing with a disinfectant solution. This is needed to assure a clean interface with the crew.

AGE Connections. - AGE connections must be strategically located throughout the WCS to assure an effective flushing cycle. The inlet connections are located at the urinals. One outlet connection is located at the fan outlet to the bacteria filter and another at the overboard dump nozzle. Three AGE connectors are provided for the commode; one to introduce water and flush solution, one to carry off the slurry and flush and a third on the vent dump to allow back flushing of this part of the system. In addition to these functional connections, drain connections might be needed if the functional outlets are not located at the lowest point in the system.

Space Vehicle Integration Study

Objective

The objective of this study was to review the various requirements for the Space Shuttle and Space Station Waste Management Systems and to recommend a single waste management technique for the Shuttle orbiter and the orbiting Space Station.

Summary of Results

Several different waste management concepts have been considered for the various orbiting Space Stations. Only two of these concepts merit consideration for the Shuttle orbiter vehicle. These are integrated vacuum drying and germicide/storage (also called liquid germicide). Studies have shown that other concepts that may be attractive for the Space Stations have excessive total

equivalent weight and volume penalties when their use is applied to the Shuttle vehicle.

A summary of the pertinent Space Shuttle and Space Station requirements is contained in Table IV.

REQUIREMENT	SPACE SHUTTLE	SPACE STATION
Solids Dump	Prohibited (stored)	Prohibited (stored)
Liquid Dump	Prohibited (stored)	Reclaimed
Gas Dump	Unresolved	Unresolved
Sex of Personnel	Mixed	Mixed
Intimate Urethral Contact	Not Recommended	Not Recommended
Duration	2-30 Days	30-180 Days
Water Reclamation	Not Recommended	Required
Bacteria Inhibition	Required	Required
Odor Control	Required	Required

SPACE SHUTTLE AND SPACE STATION
WASTE MANAGEMENT REQUIREMENTS

TABLE IV

Some of these requirements demand additional explanation. Solids and urine dumping appears clearly prohibited. Although gas dumping or venting to space is currently permitted in most Shuttle studies, consideration is being given to prohibiting dump for the Space Station and the Space Shuttle. Female, as well as male, personnel must be accommodated in both vehicles. Intimate urethral contact for collection of urine is generally not recommended for the male and is considered even more undersirable for the female. Shuttle missions are relatively short, with a seven day baseline; the Space Station resupply period is longer, with current baseline values ranging from 30 to 180 days. Water reclamation is not practical for the Shuttle but it is required on the Space Station. Bacteria inhibition in the waste and odor control area are considered essential.

Table V presents a summary of how the two selected waste management concepts meet the general requirements specified.

POTENTIAL REQUIREMENT	INTEGRATED VACUUM DRYING	GERMICIDE/STORAGE
Liquid Dump Prohibition	Added Urine Storage Capacity	Added Urine Storage Capacity
Gas Dump Prohibition	Added Compressor and Heat Exchangers	No Problem
Longer Duration	Larger Commode	Larger Germicide and Waste Storage Tanks
Water Reclamation	No Problem	Water Loss Penalty
Bacteria Inhibition	Requires Feces Distribution	Requires Germicide Distribution
Odor Control	No Problem	Some Problem

CANDIDATE SYSTEM COMPLIANCE WITH
GENERAL WASTE MANAGEMENT REQUIREMENTS

TABLE V

The above listing requires some qualification. Requirements not listed such as prohibition of solids dump present no problem for either concept. Liquid dump prohibition has the same general impact on both concepts (requires added capacity), except that there is no impact on either concept for the Space Station, where urine water is reclaimed. Gas dump prohibition requires considerable added equipment and complexity for vacuum drying, while it has no impact on the germicide/storage concept. As mission duration increases, the vacuum drying commode must provide more storage capacity for dried feces and toilet tissue, while the germicide/storage equipment must provide storage capacity for both the additional germicide and the additional waste slurry. A requirement for water reclamation has no impact on the vacuum drying concept, because urine and flush water are kept separate from the feces; the germicide/storage concept also can be designed this way, but water in the fecal slurry is not recovered and is therefore, a penalty. For effective bacteria inhibition and rapid drying, feces must be distributed in a thin layer within the commode; the germicide/storage equipment, on the other hand, must provide intimate mixing of the germicide and feces. Vacuum dried feces are odorless, while feces inactivated with an acceptable germicide are expected to give off a slight odor.

Considering the foregoing characteristics, the two concepts are compared for a gas venting situation and then for a no-vent situation. Table VI-A compares the two systems for the Space Shuttle vehicle venting mode of operation, and Table VI-B presents a similar system comparison for the Space Shuttle with gas venting prohibited. Table VII presents a comparison for the Space Station with gas venting prohibited.

CRITERIA	EVALUATION	
	INTEGRATED VACUUM DRYING	GERMICIDE/STORAGE
Performance	Good	Good
Safety	Good	Fair
Reliability	Good	Good
Availability	Very Good	Fair
Equivalent Weight, lb.	189	246
ROM Cost Factor	1.0	1.2
Volume, ft ³	17	22
Complexity	Very Good	Fair
Flexibility	Good	Fair
Durability	Good	Fair
Refurbishment	Good	Good
Checkout Capability	Good	Good

SPACE SHUTTLE EVALUATION WITH GAS VENTING PERMITTED

TABLE VI-A

CRITERIA	EVALUATION	
	INTEGRATED VACUUM DRYING	GERMICIDE/STORAGE
Performance	Good	Good
Safety	Good	Fair
Reliability	Fair	Good
Availability	Fair	Fair
Equivalent Weight, lb.	221	246
ROM Cost Factor	1.2	1.2
Volume, ft ³	20	22
Complexity	Fair	Fair
Flexibility	Good	Fair
Odor Control	Good	Good
Refurbishment	Good	Good

SPACE SHUTTLE EVALUATION WITH GAS VENTING PROHIBITED

TABLE VI-B

CRITERIA	EVALUATION	
	INTEGRATED VACUUM DRYING	GERMICIDE/STORAGE
Performance	Good	Fair
Safety	Good	Fair
Availability	Good	Fair
Automation Potential	Good	Fair
Maintainability Potential	Good	Good
Power, watt	310	320
Weight, lb.	720	804
Volume, ft ³	81	69
Sterilization Potential	Good	Fair
Resupply Penalty, lb.	426	308
Thermal Power Flexibility	Very Good	Very Good
Interface Simplicity	Good	Very Good

SPACE STATION EVALUATION WITH GAS VENTING PROHIBITED

TABLE VII

These studies and comparisons indicate that the integrated vacuum drying concept should be selected as the Shuttle baseline. This concept is definitely preferred for both the Space Shuttle and Space Station in a situation where gas venting is permitted; it also is selected as the preferred system where gas venting is prohibited. However, the germicide storage concept is shown to be sufficiently attractive that development at a future date may be considered.

DEVELOPMENT UNIT DESIGN AND FABRICATION

The Waste Collection Subsystem Development Unit was designed and built with a degree of sophistication that allowed maximum use of commercial-grade hardware, minimizing cost without compromising the program objectives. The operational requirements to which the WCS was designed are specified in Appendix A. The first task in the design phase was the selection of a urinal and seat configuration based on a subjective evaluation of various concepts, and the final selection of the feces-processing method. Once these were established, the overall system was evolved.

Urinal Concept Evaluation

The urinal concept evaluation was conducted utilizing the services of four male and four female volunteer test subjects. The urinal mock-ups were assembled together with a commode and support equipment required to provide functional urinals for evaluation. The complete assembly was set up in a controlled access room for evaluation. Figure 24 depicts the test set-up utilized for the mock-up evaluations.

Four urinal concepts similar to those described in the "Urine Elimination Study" and depicted in figures 7, 8, 9, and 10 of this report were evaluated. The four urinal concepts were installed on the commode/urinal assembly during four successive days. Each test volunteer utilized each concept for one day of normal urine elimination; a data sheet was completed after each urination. Table VIII is the data sheet utilized during the evaluation.

Table IX presents a summary of the urinal concept evaluation. The choice of test volunteers by a wide margin, was test Concept No. 2. This concept is essentially the same as the concept illustrated in figure 7 of this report. However, the test unit did not have the rear entrainment air flow. This feature was evaluated in the concept that included the flow deflector. In post-test discussions with the test volunteers, their consensus was that the rear flow was not objectionable and would not create any problems if incorporated into the selected concept. It also was pointed out that the mock-up concept actually was larger than required and that the final urinal could be reduced in size.

A separate test was conducted with the test volunteers in which the air entrainment flow reached 40 ft/sec velocity on the vulva area. The reaction of all the test volunteers was that this flow velocity would not cause any problems from either a chilling or inhibiting aspect.

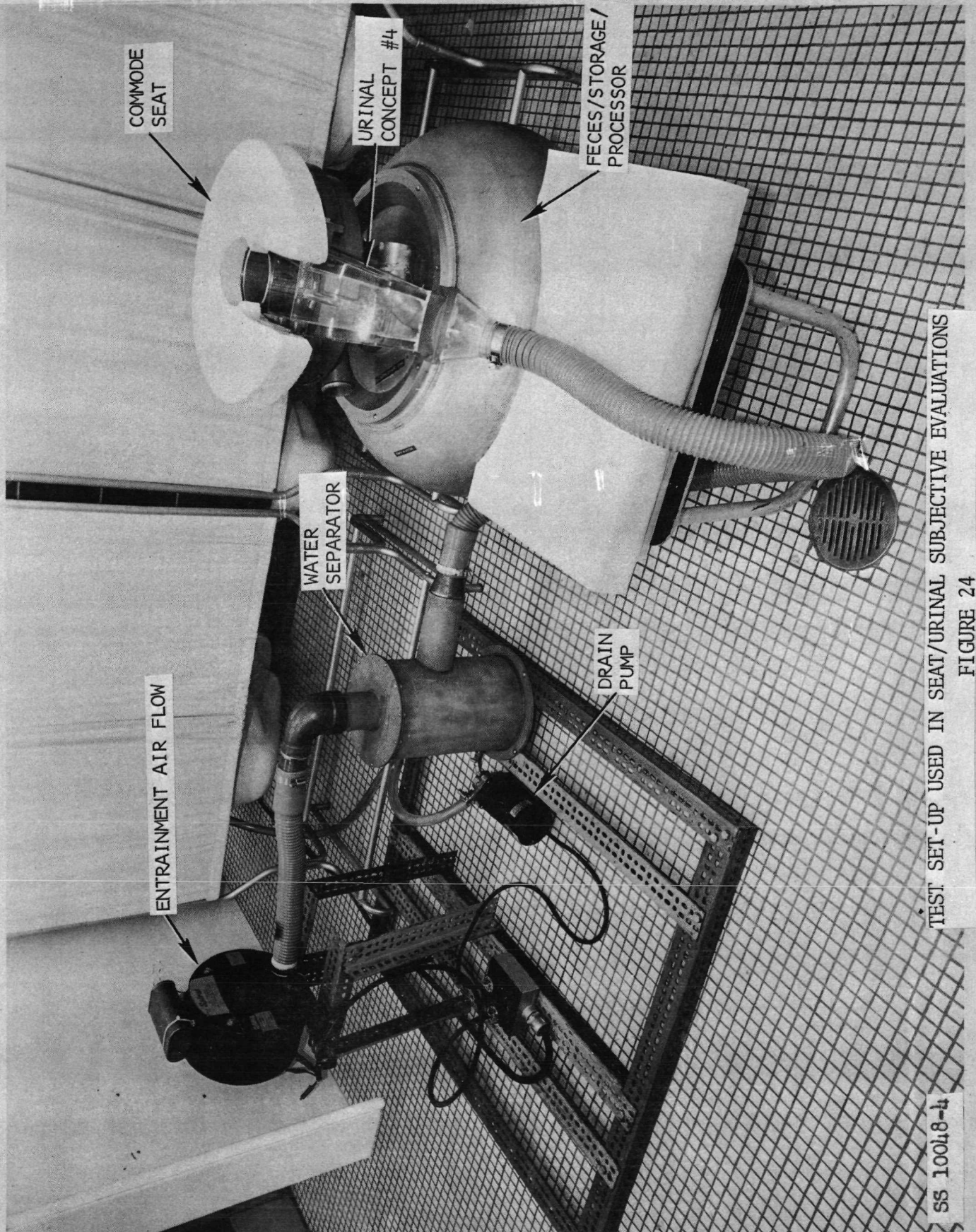

TEST SET-UP USED IN SEAT/URINAL SUBJECTIVE EVALUATIONS

FIGURE 24

SS 10048-4

Test Subject No. _____		Date _____		
Urinal Concept _____				
<p>1. <u>Convenience:</u></p> <p>Comments: _____</p>	<p>Excellent</p> <p>_____</p>	<p>Good</p> <p>_____</p>	<p>Acceptable</p> <p>_____</p>	<p>Not Acceptable</p> <p>_____</p>
<p>2. <u>Hardware Comfort:</u></p> <p>Comments: _____</p>	<p>Excellent</p> <p>_____</p>	<p>Good</p> <p>_____</p>	<p>Acceptable</p> <p>_____</p>	<p>Not Acceptable</p> <p>_____</p>
<p>3. <u>Functional Comfort:</u></p> <p>Comments: _____</p>	<p>Excellent</p> <p>_____</p>	<p>Good</p> <p>_____</p>	<p>Acceptable</p> <p>_____</p>	<p>Not Acceptable</p> <p>_____</p>
<p>4. <u>Splash:</u></p> <p>Comments: _____</p>	<p>Excellent</p> <p>_____</p>	<p>Good</p> <p>_____</p>	<p>Acceptable</p> <p>_____</p>	<p>Not Acceptable</p> <p>_____</p>
<p>5. <u>Collection Performance:</u></p> <p>Comments: _____</p>	<p>Excellent</p> <p>_____</p>	<p>Good</p> <p>_____</p>	<p>Acceptable</p> <p>_____</p>	<p>Not Acceptable</p> <p>_____</p>
<p>6. <u>Overall Evaluation:</u></p> <p>Comments: _____</p>	<p>Excellent</p> <p>_____</p>	<p>Good</p> <p>_____</p>	<p>Acceptable</p> <p>_____</p>	<p>Not Acceptable</p> <p>_____</p>

URINAL CONCEPT EVALUATION DATA SHEET

TABLE VIII

Concept	Convenience	Hardware Comfort	Functional Hardware	Splash	Collection Performance	Overall Evaluation	Totals
#3 Two Position Urinal, illustrated in figure 9							
Male	Excellent	2	2	1	2	2	10
	Good	1	3	3	6	3	19
	Acceptable	3	2	3		2	12
	Not Acceptable						
Female	Excellent	1	1				2
	Good	2	2	3	3	2	14
	Acceptable					1	1
	Not Acceptable				1		1
#1 Baseline Urinal, illustrated in figure 7							
Male	Excellent	5	4	3	4	4½	22½
	Good		1	2	1	½	7½
	Acceptable						
	Not Acceptable						
Female	Excellent	5	5	4	4	5	28
	Good	1	2		1	1	5
	Acceptable	1		3	2	1	9
	Not Acceptable					2	
#4 Variable Area Concept, illustrated in figure 10							
Male	Excellent		1		2		3
	Good	5	3	4	3	4	22
	Acceptable		1	1		1	5
	Not Acceptable					2	
Female	Excellent		1		1		3
	Good	5	3	4	4	5	23
	Acceptable	2	3	3	2	1	17
	Not Acceptable					5	
#2 Baseline with Flow Deflector, illustrated in figure 8							
Male	Excellent						
	Good	1	2	4	4	4	18
	Acceptable	2½	2			3	5½
	Not Acceptable	½				1	½
Female	Excellent				4	3	7
	Good	4	7	5	2	3	27
	Acceptable	4	1	3	2	2	14
	Not Acceptable						

SELECTED CONCEPT: #1 Baseline Urinal

URINAL CONCEPT EVALUATION SUMMARY

TABLE IX

The final urinal design is depicted in cross-section in figure 25 and is similar in concept to that depicted in figure 7. The urinal opening is four inches by six inches. The urinal incorporates two directional air flows to collect the urine. The main flow comes in between the user's thighs and is in the order of 100 cfm. A rear entrainment flow of 35 cfm enters from the back of the urinal to prevent the urine from sweeping back over the user or going into the feces collection portion of the commode. Part of the rear flow is diverted down the back surface of the urinal to carry the liquid away. The urinal incorporates an integral flush manifold for cleansing. When the cover is closed during flushing the air flow is drawn in through slots in the side of the urinal to sweep the flush water out of the urinal. This final design urinal does not have any moving parts. Figure 26 depicts the urinal as installed on the commode assembly.

Seat Concept Evaluation

The same eight test volunteers who participated in the urinal evaluation also evaluated four seat configurations. Seat concepts 1, 2 and 3 which were evaluated correspond to those depicted in figures 13, 14, and 15 as evolved during the seat design study. Concept No. 4 was a slight variation of Concept No. 3, allowing greater anal wipe access.

Table X is the evaluation sheet filled out by each of the test volunteers. Table XI is a summary of the seat evaluation. The selected concept was Concept No. 1, the least contoured of the seats and the closest to a normal terrestrial commode seat. The summary table shows that this concept received the most "excellent" and "good" ratings by the test volunteers and was the preferred seat by a significant margin. This selected seat concept was utilized during the urinal testing. Figure 26 depicts the seat as installed on the commode assembly.

Feces Processing Selection

The third major area dictating the design of the waste collection subsystem is the feces-processing method. Prior to the initiation of the actual design, a review was made of the results of the NASA Langley Research Space Shuttle EC/LSS Study and the McDonnell Douglas Corporation and North American Rockwell Corporation Phase B, Space Shuttle EC/LSS Studies. The results of these studies were integrated into the Space Vehicle Integration Study discussed earlier in this report and the integrated vacuum drying concept was selected as the method to be utilized in the Development Waste Collection Subsystem.

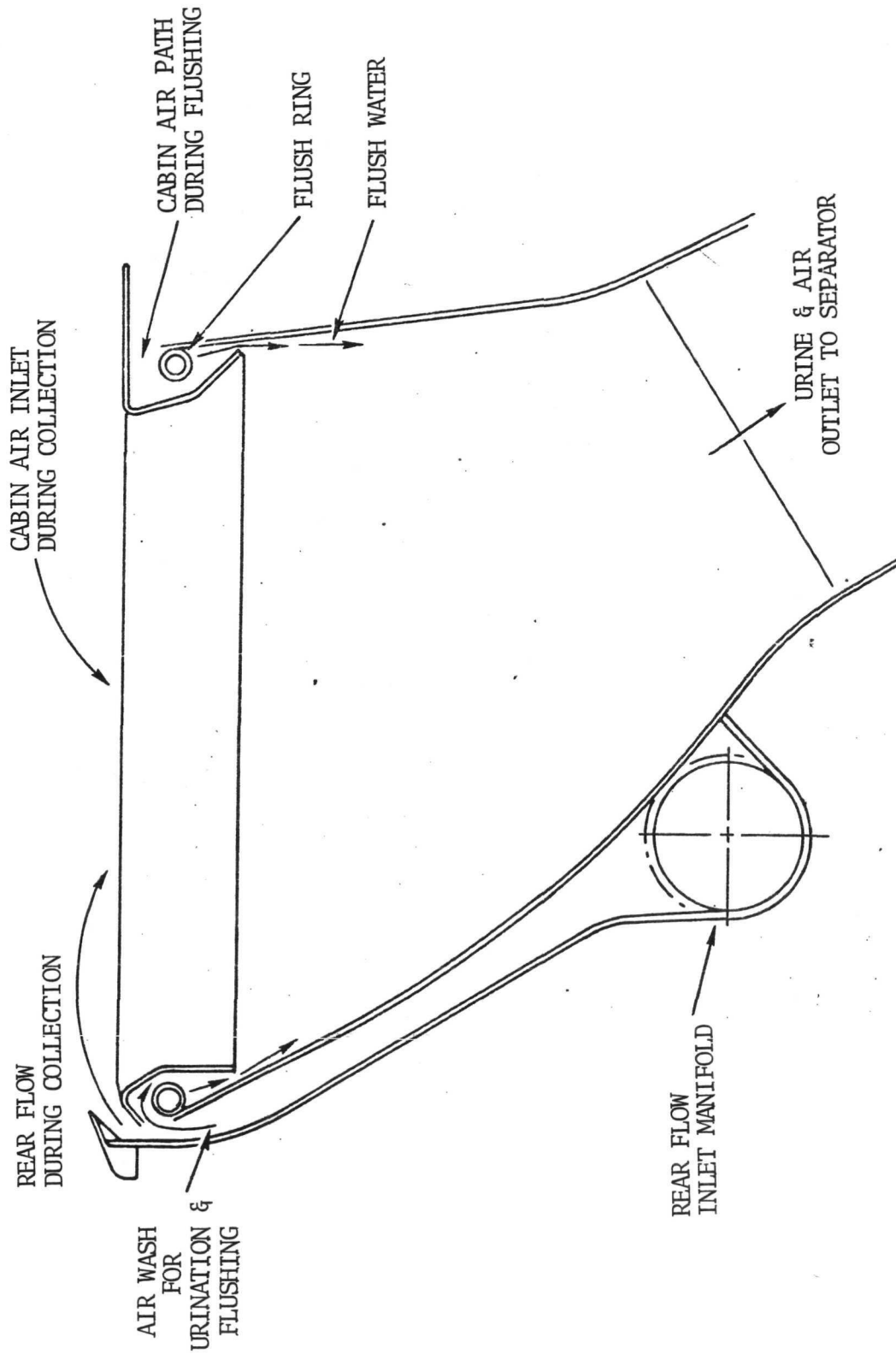

SELECTED URINAL CONFIGURATION
(CROSS SECTION)

FIGURE 25

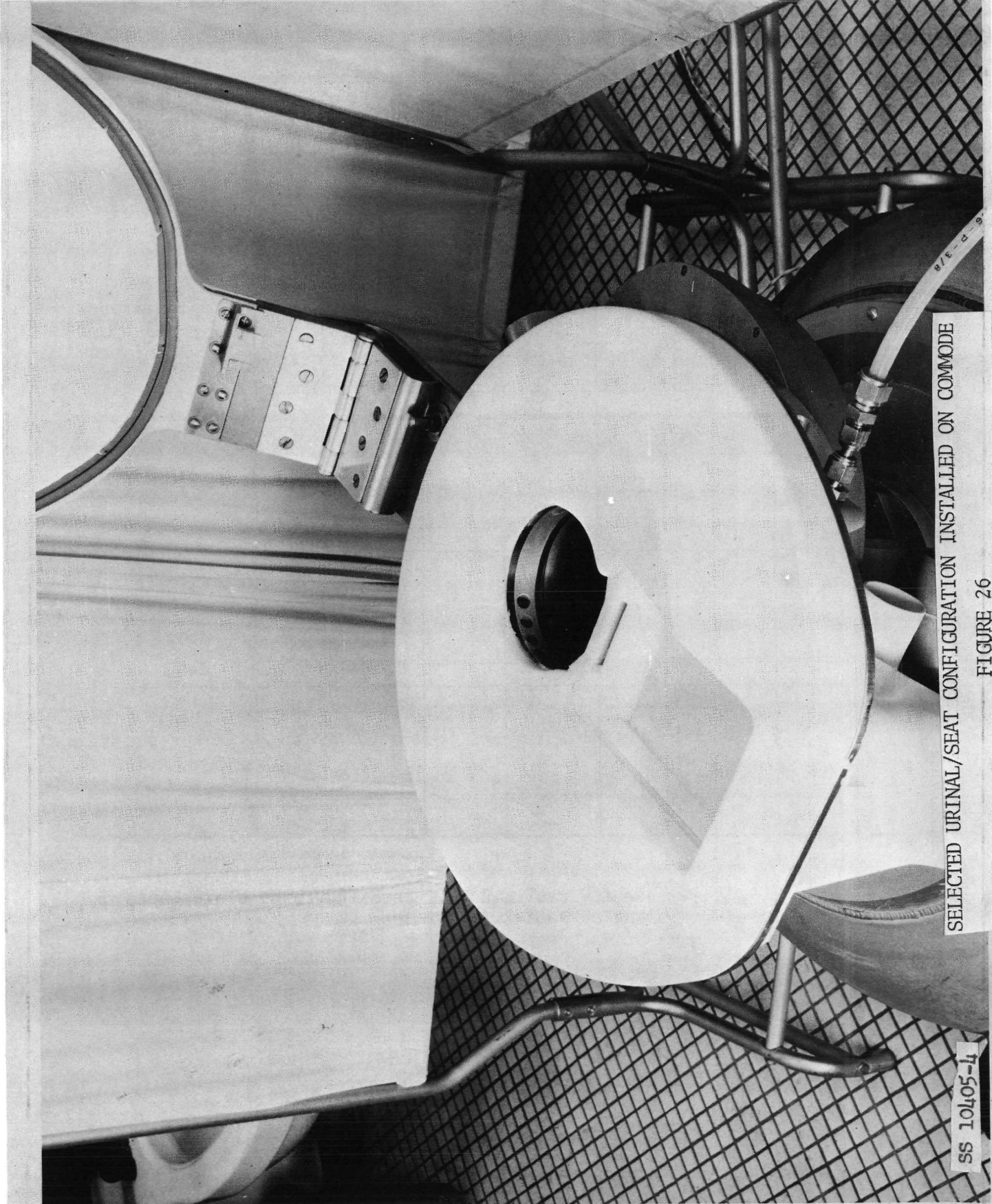

SELECTED URINAL/SEAT CONFIGURATION INSTALLED ON COMMODE

FIGURE 26

SS 10405-4

Test Subject # _____	Date _____			
<u>Seat #1</u>	<u>Excellent</u>	<u>Good</u>	<u>Acceptable</u>	<u>Not Acceptable</u>
Comfort:	_____			
Function:	_____			
Wipe Access:	_____			
Comments:	_____			
 <u>Seat #2</u>	 <u>Excellent</u>	 <u>Good</u>	 <u>Acceptable</u>	 <u>Not Acceptable</u>
Comfort:	_____			
Function:	_____			
Wipe Access:	_____			
Comments:	_____			
 <u>Seat #3</u>	 <u>Excellent</u>	 <u>Good</u>	 <u>Acceptable</u>	 <u>Not Acceptable</u>
Comfort:	_____			
Function:	_____			
Wipe Access:	_____			
Comments:	_____			
 <u>Seat #4</u>	 <u>Excellent</u>	 <u>Good</u>	 <u>Acceptable</u>	 <u>Not Acceptable</u>
Comfort:	_____			
Function:	_____			
Wipe Access:	_____			
Comments:	_____			
Preferred Seat:				
Comments for Improvement				

COMMODE SEAT EVALUATION DATA SHEET

TABLE X

	Excellent		Good		Acceptable		Not Acceptable	
	Male	Female	Male	Female	Male	Female	Male	Female
Seat #1(fig. 13)								
Comfort		4	4					
Function		1	3	2	1	1		
Wipe Access				3	4	1		
Totals		5	7	5	5	2		
Seat #2(fig. 14)								
Comfort			1		2	1	1	3
Function					4	4		
Wipe Access			1		3	3		1
Totals			2		9	8	1	4
Seat #3(fig. 15)								
Comfort			3		1			4
Function			3		1	3		1
Wipe Access			1		3	3		1
Totals			7		5	6		6
Seat #4(fig. 15)								
Comfort	1			2	1	1	2	1
Function			1	2	3	2		
Wipe Access			1	1	3			3
Totals	1		2	5	7	3	2	4

Expressed Preference: #1 Seat 5.5 Test Volunteers
 #3 Seat 1.5 Test Volunteers
 #4 Seat 1 Test Volunteer

Selected Concept: Seat #1

COMMODE SEAT EVALUATION SUMMARY

TABLE XI

System Description

The operational schematic of the Development WCS is presented in figure 27. The subsystem is separated into four assemblies: the commode assembly; the WCS control assembly; the anal-wash kit; and the no-vent kit.

Commode Assembly

The commode assembly serves as the waste collector and feces processing/storage facility. This portion of the system consists of the previously described commode seat with a cover and latching assembly, and the urinal with an integral water-flush manifold and associated ducting for the transfer of urine. The seat is attached to a fecal-transfer duct, which contains provisions for entrainment flow for separating and moving the stool from the anus to the storage/processing section and an integral water flush manifold for collector cleansing. In addition, an anal-cleansing system is incorporated to permit evaluation of this feature in a waste collection system. The transfer duct also contains the locating-air-jet nozzle to assist the user in positioning properly on the seat.

The interface between the transfer duct and the storage/processor is the collector valve. This valve is a manually actuated gate valve and is an important design feature of the commode assembly. When closed, it seals the storage/processor to permit vacuum drying of the feces, and in its open position allows the proper transfer of solid wastes through it. The valve design utilizes a gate, without using the normal shear-type seals that are inherently poor vacuum seals. An actuation scheme which lifts and rotates the gate is used instead. The gate valve also contains an integral bypass to allow anal-wash water or collector-flush water to be transferred to the waste-water collector or processor without passing through the feces storage/processor portion of the unit.

The feces storage/processor unit is an oblate spheroid modified to allow integration of a slinger and air-flow ducts. This configuration allows maximum storage within the distribution limits of the slinger for a minimum collector weight. The unit has a minimum storage capacity of 42 man-days of feces and cleansing wipes. The outlet air flow manifold achieves the desired flow patterns in the collector and has a large filter area to minimize the possibility of clogging in zero-gravity. From one-g operation, a trough is provided at the bottom of the feces collector to keep loose particles out of the air stream and away from the air-outlet duct. The slinger and air-inlet and air-outlet duct locations are positioned so that air flow must pass through the slinger tines. This arrangement subjects all the deposited feces and wipes to the shredding and slinging action. Any particles that are not forced outward by the slinger in zero-gravity will be contained by the air flow and carried through the tines. The slinger relies on a knife-edge tine design to shred and distribute the feces, wipes, and other wastes which may be deposited in the commode. The slinger motor is mounted externally on the feces storage/processor, permitting

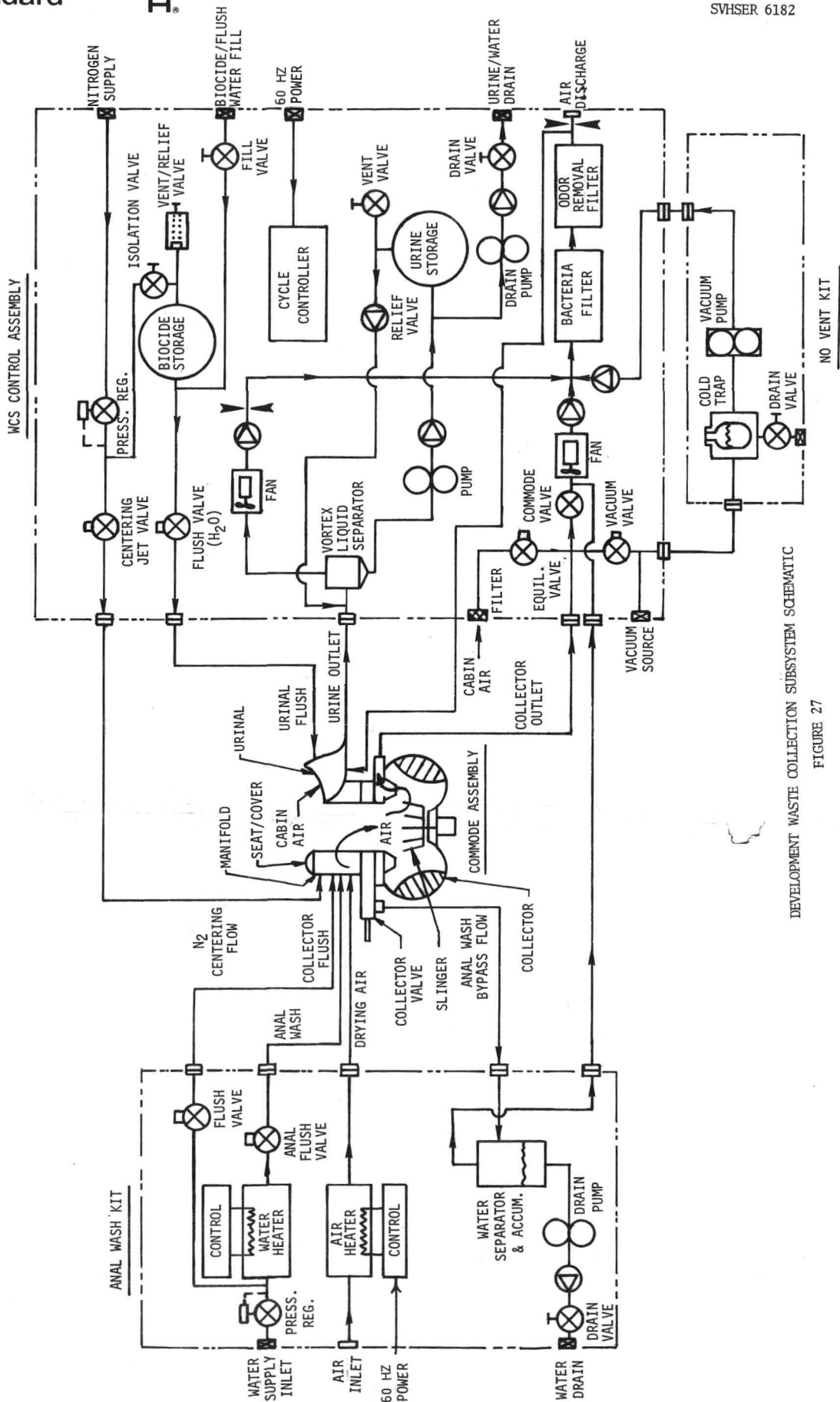

DEVELOPMENT WASTE COLLECTION SUBSYSTEM SCHEMATIC

FIGURE 27

efficient air cooling and ease of maintenance of the motor, as it is the most likely component in the assembly to fail. The feces air-entrainment flow pattern and basic slinger operation had been successfully tested in the Space Station Prototype development program (NASA/JSC Contract NAS 9-10273)(1). The urinal, seat, and fecal-transfer duct and their integration with the unit are the new design requirements.

Waste Collection Subsystem Control Assembly

The WCS Control Assembly consists of two consoles containing all of the ancillary equipment required to operate the commode assembly and store the liquid waste products. The ancillary equipment, including the operational controls, is located next to the commode assembly to allow convenient operation by the test subjects. The majority of components in the assembly is commercial equipment, which allows functional system operation for testing but is not representative of flight weight and volume. The control assembly consists of five major sections.

Positioning-Jet Section: The user-positioning-jet section utilizes a solenoid-operated valve and a manually adjustable pressure regulator connected to either an air or nitrogen source. The valve controls the flow of gas to the positioning jets located in the commode assembly.

Urinal Flush/Biocide Supply Section: The urinal flush water/biocide supply section, consists of a bladder tank pressurized by the same pressure regulator used in the positioning-jet system, and a solenoid-operated flush valve. The flush cycle can be varied by an adjustable timer which controls the time the solenoid valve is open. The bladder tank has a fill system and a vent and relief valve.

Urine Transfer and Storage Section: The urine transfer and storage section consists of a fan which provides the required urine entrainment air flow, a vortex liquid/air separator, pumps, a urine storage tank and appropriately placed debris filters. The liquid/air mixture is drawn from the urinal through the vortex liquid/air separator. It should be noted that the original liquid/air separator planned for use in the WCS was a government-furnished "Skylab" rotary urine separator. The maximum air flow capacity of the rotary separator is 5 scfm and the maximum liquid flow rate is 5.25 lbs/min. In comparison, the WCS requirement is 135 scfm, with a maximum liquid flow rate of 3 to 15 lbs/min. during the flush cycle. Because of the high flows required, the rotary separator could not be utilized without incorporating into the system a first stage separator and reservoir to limit the flow to a level that the rotary separator could handle. It was concluded that a simpler, more reliable system could result from using a one-stage separator process in place of the two-stage process required if the rotary separator were utilized. The vortex concept

(1) Passalacqua, J. Test Report Two Stage Waste Management System, HS report, SSP Document No. 63, Contract NAS 9-10273, 1970.

was chosen because it will handle the required flows and requires less maintenance than an elbow-wick-type separator, i.e., replacement of a urine soaked wick would be unpleasant. Once the liquid has been separated from the air, the urine is pumped into a stainless steel storage tank where the urine is held until ground servicing. A pump and valves for ground servicing also are provided. The separated air is drawn through the fan and through the bacteria and odor removal filters. Air for the urinal rear entrainment flow is drawn downstream of the filters and the remaining air is transferred to the cabin atmosphere. The bacteria filter is a Flanders-type absolute air filter, and the odor removal filters are two canisters, individually packed with Purafil and charcoal. Purafil is a solid odoroxidant manufactured by Marbon Chemical Division of Borg-Warner Corporation. The basic material is activated alumina (Al_2O_3) impregnated with potassium permanganate ($KMnO_2$). The charcoal contained in the filter is a type AC activated charcoal manufactured by Barnebey-Cheney, Inc.

Feces Transfer and Vacuum Drying Section: The transfer of feces from the user into the storage/processing portion of the commode is accomplished by air entrainment. The required air flow is provided by a second fan independent of the urinal air entrainment fan. The feces entrainment air is directed from the commode through the previously mentioned bacteria and odor removal filters and into the cabin. Three solenoid valves are used to control the air flow in the commode and the vacuum drying process for the commode. One valve controls exposure to vacuum, the second valve is used to equalize pressure in the commode, and the third valve allows the entrainment flow to be directed through the filters and into the cabin.

Control Panel Section: The control panel to operate the basic system is contained within the control console. The controller contains the required timers and relays to allow operation of the system and status lights to enable the user to ascertain system status. Figure 28 is a photograph of the control panel. The panel contains a system start switch, a positioning jet activation switch, a urinal flush/shutdown switch, and a switch that allows shutdown without flushing the urinal. The latter two switches are interlocked with a switch on the commode cover, which does not allow flush activation until the commode cover is closed. In addition, the panel contains status lights to indicate the system operating status, when a vacuum is present in the commode and when the system is ready for operation.

The Development Waste Collection Subsystem operates on 115 VAC, 60 hertz power to facilitate ground testing; a motor generator is provided for use with 28 VDC aircraft power for zero-gravity testing.

WASTE COLLECTION SUBSYSTEM CONTROL CONSOLE

DO NOT PRESS VACUUM GAGE READING FIRST !!!

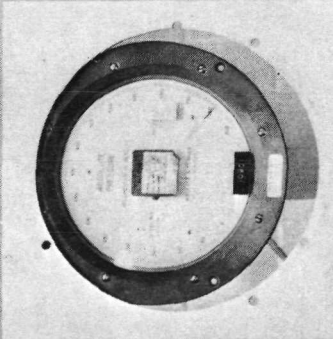

- OPERATING INSTRUCTIONS**
1. PRESS SYSTEM START BUTTON
 - LIFT COVER ATTAIN PROPER POSITION
 2. VACUUM OFF LIGHT ILLUMINATED
 - OPEN COLLECTOR MANUAL VALVE
 - UTILIZE SYSTEM
 - DEPOSIT WIPES IN RECS COLLECTOR
 3. SYSTEM SHUTDOWN
 - CLOSE COLLECTOR VALVE
 - LOWER SEAT COVER
 - A. ORIGINAL USED PRESS FLUSH/SHUTDOWN BUTTON
 - B. ORIGINAL NOT USED PRESS SHUTDOWN BUTTON

VACUUM ON

VACUUM OFF

SYSTEM READY

SYSTEM START

POSITIONING JET

FLUSH/SHUTDOWN

SHUTDOWN

PRESS BUTTON/HOLD

PRESS BUTTON

PRESS BUTTON

PRESS BUTTON

WASTE COLLECTION SUBSYSTEM CONTROL PANEL

FIGURE 28

C 3798

Anal Wash Kit

An anal-wash kit is provided with the basic waste collection subsystem. Trade-off studies, conducted to determine the best method of post-elimination cleansing, indicated that the preferred method of anal cleansing for the Shuttle vehicle is the use of wet-dry wipes disposed of in the commode. However, it was thought that the anal wash approach could not be totally eliminated, primarily because of the lack of zero-gravity test data and the possible necessity to wet the anus as a result of the drying action of the feces-separation and entrainment air flow. Therefore, an anal-wash kit was included to obtain additional test information. The anal-wash kit, contained in its own console, interfaces with the collector valve and feces-transfer duct on the commode assembly and the inlet to the commode fan. The unit consists of a water heater, solenoid valves to control the flow of anal-cleansing and flush water, and an air heater to provide warm air for drying the anal area after washing. The kit also contains a water separator and drain equipment for the anal-wash and flush water. The air flow is drawn through the WCS control assembly and exits through the bacteria and odor-control filters contained in the WCS control assembly.

The anal wash kit incorporates its own control panel. The panel contains a switch to turn on the air heater, a rheostat for selecting the desired air temperature and switches to activate the anal wash and the flush systems. The anal wash and flush switches are interlocked with a switch activated by the commode manual collector valve so the anal wash cannot be operated unless the collector valve is closed. This precludes the possibility of excess water entering the vacuum drying area of the commode. Switches are provided to deactivate the air heater and to operate the separator drain pump. Status lights are provided to allow the user to determine what function of the operating cycle is being performed. Figure 29 is a photograph of the control panel. The anal wash kit operates on 115 VAC, 60 hertz power.

No-Vent Kit

Various phases of the Space Shuttle mission may preclude the venting of gases or vapors into space. Because the basic method of feces processing and bacteriological control selected for the Shuttle WCS was the venting of fecal gases to space vacuum, a no-vent study, discussed earlier in this report, was conducted. This study indicated that the best method of feces processing under no-vent conditions still would be by exposure to vacuum by use of a vacuum pump. The fecal exhaust gases from the vacuum pump would be kept under control by passing them through the same odor-and bacteria-control filters as the air entrainment flow. For the development WCS, a vacuum pump and a cold trap upstream of the pump to condense moisture are provided.

ANAL WASH CONSOLE

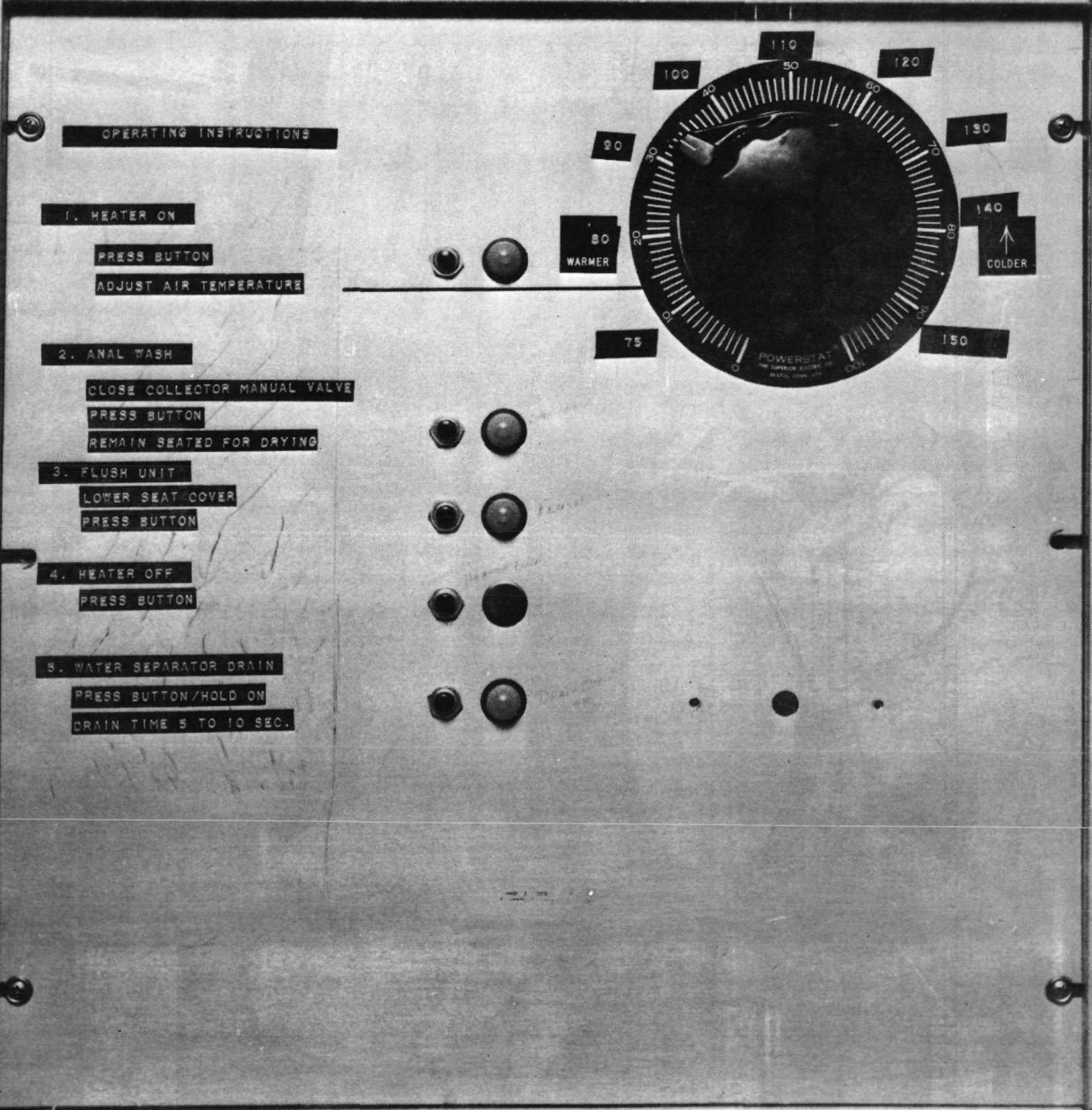

OPERATING INSTRUCTIONS

1. HEATER ON

PRESS BUTTON
ADJUST AIR TEMPERATURE

2. ANAL WASH

CLOSE COLLECTOR MANUAL VALVE
PRESS BUTTON
REMAIN SEATED FOR DRYING

3. FLUSH UNIT

LOWER SEAT COVER
PRESS BUTTON

4. HEATER OFF

PRESS BUTTON

5. WATER SEPARATOR DRAIN

PRESS BUTTON/HOLD ON
DRAIN TIME 5 TO 10 SEC.

ANAL WASH KIT CONTROL PANEL

C 3796

FIGURE 29

DEVELOPMENT WASTE COLLECTION SUBSYSTEM GROUND TESTS

The ground testing of the Development Waste Collection Subsystem was conducted in three distinct portions: 1) Functional and Parametric Tests; 2) 28 man-day tests; and 3) University Tests. The test results are discussed in this section. All subjective comments were recorded on test summary data sheets. A sample data sheet is included as Appendix B of this report.

Functional and Parametric Tests

Functional Tests

The Development Waste Collection Subsystem was installed in a lavatory adjacent to the office area of the Space Systems Department for the convenience of the test subjects. Figure 30 depicts the system as installed. The functional testing revealed several initial startup problems such as vacuum leaks, valves operating backwards and electrical problems. These problems were all corrected and the unit setup for actual operation.

The commode air entrainment flow was established at 25 scfm. The urinal flows were established at measured values of 97 scfm being drawn into the urinal through the top and 35 scfm being pushed into the urinal through the back flow opening. The air velocity at the backflow opening was found to be 30 feet per second; the velocity coming into the urinal through the top varied between 28 and 35 feet per second depending on location of the measuring device within the urinal opening. Velocity on the walls was measured and averaged 25 feet per second. A hot wire anemometer was the device used to measure the air velocity at various locations in the urinal.

The urinal flush system was checked and the flushing action was excellent. The system was originally setup to use 0.80 pounds of water per flush. After evaluation, this amount was reduced to 0.50 pounds and an effective flush was still obtained. It also was found that the flush water tank pressure could be reduced to 20 psig, although original calculations had indicated that 30 psig would be required.

The functional testing also pointed out the need for a slight redesign in the vortex separator in future units. It was discovered that the separated fluid entering the sump had a velocity sufficiently high to cause the fluid to continue rotating around the walls, finding a path to the center of the sump along the base to the pumping exit, thus leaving a void in the center of the sump. The system as designed, allowed urine to flow into the sump without the drain pump operating since the sump had sufficient capacity for collecting normal micturitions. The drain pump was activated by the initiation of the flush cycle. Due to the liquid action within the sump it was found that it took longer to drain the sump than had been anticipated. Thus when the flush was

C 3741

VACUUM GAGE
(TEST USE ONLY)

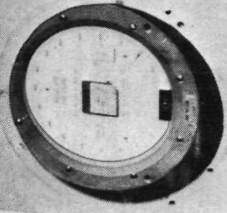

UNIT INDICATOR LIGHTS (OPTIONAL)

- OPERATING INSTRUCTIONS**
- 1. PRESS SYSTEM START SWITCH
 - 2. SYSTEM OFF LIGHT GREEN FLICKS
 - 3. PRESS COLLECTION MANIPULATOR
 - 4. PRESS SYSTEM STOP SWITCH
 - 5. PRESS SYSTEM STOP SWITCH TO PREVENT COLLECTION
 - 6. PRESS COLLECTION VALVE
 - 7. PRESS SYSTEM STOP SWITCH TO PREVENT COLLECTION
 - 8. PRESS SYSTEM STOP SWITCH TO PREVENT COLLECTION
 - 9. PRESS SYSTEM STOP SWITCH TO PREVENT COLLECTION
 - 10. PRESS SYSTEM STOP SWITCH TO PREVENT COLLECTION

CONTROL CONSOLE

OPERATING CONTROLS
LIQUID/AIR SEPARATOR
URINAL FANS
URINE STORAGE
FLUSH SYSTEM

MALE/FEMALE URINAL



ODOR/BACTERIA FILTERS
VACUUM VALVES
COMMODE FAN

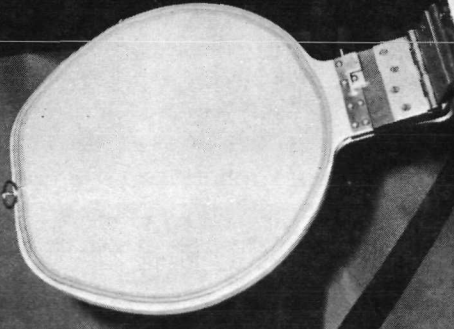

ZERO & 1 "G" SEAT

MANUAL ISOLATION VALVE

FECES STORAGE/PROCESSOR

HAMILTON STANDARD WCS TEST INSTALLATION

FIGURE 30

activated the sump flooded, backing up into the main body of the separator and causing some liquid carry-over out of the unit. The performance was corrected by allowing the urine pump to operate all the time the urinal fans are operating. Future designs of the vortex separator will have the sump exit located at the side of the unit. Figure 31 depicts the vortex separator configuration utilized for the testing discussed herein.

Parametric Tests

The parametric test series was conducted after the operational problems had been corrected. The test subject comments recorded during the parametric tests are tabulated in Tables XII through XV and are discussed in the following sections.

Failure Mode Test With Centering Jets Inoperative. - This test was conducted to determine the ability of test subjects to properly position themselves on the collector without the aid of centering jets. Prior to the initiation of this test the test volunteers used the WCS and centering jets for two days to become accustomed to the use of the equipment. The use of the system without the centering jets did not present problems to the test volunteers. It was noted that on two of the defecations some soiling occurred on the unit but the test subjects attributed the soiling to diarrhetic type movements rather than lack of use of the centering jets. It was found that in succeeding tests the volunteers generally stopped using the centering jets about 50 percent of the time and reported that when used, it was to verify position rather than to attain position.

The test subjects' comments for these tests are recorded in Table XII. Comments 9 and 10 indicate that someone had put tissue into the urinal. The tissue had been drawn into the separator, became wet and shredded, and the small pieces had clogged the urine drain pump and the separator exit. Urine and flush water built up in the separator, dispersed through the air system and caused one of the fans to seize. The urine collection system was disassembled, cleaned and reassembled. To preclude the possibility of this anomaly recurring, a screen was installed at the entrance to the water separator to trap any items inadvertently put into the urinal. The comments on splashing by the female subjects are discussed in the airflow variation test section.

Position Variation. - This test was conducted to determine the allowable variation in user position from the design point, where successful waste elimination can be performed. The subjective comments recorded during this test are reported in Table XIII. The test was conducted with the test volunteers moving to the side, forward and backward until the seat or position felt uncomfortable, and then having the volunteer utilize the system. The results indicate that side movement of one inch caused soiling of the unit for both feces collection and female urination. In addition, the feces air entrainment flow appears to impinge directly on the anus area, causing excessive soiling

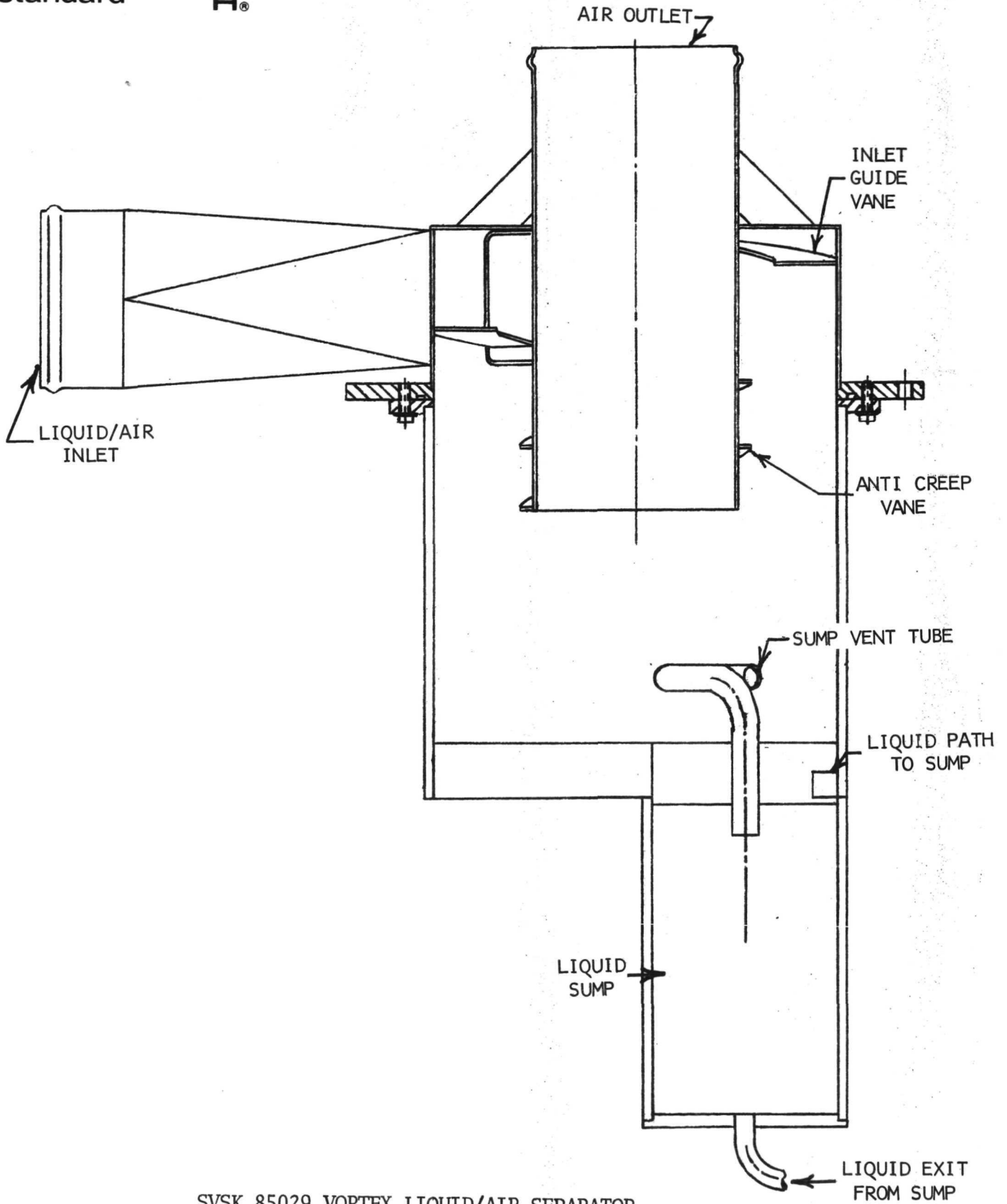

SVSK 85029 VORTEX LIQUID/AIR SEPARATOR
(Cross Section)

FIGURE 31

COMMENT NUMBER	TEST SUBJECT	COMMENT
1	Male A	Felt urinal backflow and air flow was high; everything else good.
2	Male B	Air flow gave tickling sensation during urination, okay once I got used to it.
3	Male A	Must get used to air flow; positioning jet felt cool but good effectiveness.
4	Male C	Position effectiveness, "excellent, you know where you are."
5	Female A	Recorded some backplash, caused by backflow spraying urine. (See note "A".)
6	Male B	Found it difficult to ascertain position using jet with fans operating, without fans okay.
7	Female B	Recorded splash on front of seat and thighs; also felt noise inhibited use. (See note "B".)
8	Male C	Urinal air flow felt "delightful".
9	Male A	Urinal air flow felt better - some odor noted of urine. (See note "C".)
10	Male A	Soiled back of commode inlet; loose movement - strong urine odor. (See note "C".)
11	Male C	Noted at low bladder pressure air flow adhered urine to walls quickly. Loose movement soiled the seat and area between gate valve and seat. (See note "D".) No problem without jet, but somewhat apprehensive on position initially.
12	Male B	Only got normal buttock soiling.
13	Female A	Splashing was better but still not acceptable. (See note "E".)
14	Female B	Seventy-five percent better on splash but still had some. (See note "E".)

- NOTES:
- A. Backflow was set at 35 scfm, it will be reduced to 25 scfm for next day's test.
 - B. Backflow at 35 scfm.
 - C. Blocked separator, see discussion, flow reduced to 25 scfm.
 - D. Seat soiling apparently came from wipe; approximately one half square inch of soiled area.
 - E. Backflow at 25 scfm.

COMMENT NUMBER	TEST SUBJECT	COMMENT
1	Male A	Moved forward 1-1/2 inches; urination okay; fecal elimination quite a lot of soiling on user and transfer duct; position did not feel normal.
2	Male C	Moved forward one inch; beyond that felt unnatural.
3	Female B	Moved backward one inch; got spray from backflow onto legs.
4	Female A	Moved back one inch, got splash on legs; closed legs, still got splash on bottom.
5	Female B	Moved to side one inch, urine sprayed on side of urinal. Also, felt noise still inhibiting but getting better each day.
6	Male A	Moved to side one inch, air flow plastered feces on user and equipment.
7	Male C	Moved one inch - soiled user and equipment. Felt seat locates user properly on side.
8	Male A	Moved backward 3/4 inch, not natural position; had to move forward to spread buttocks, quite a lot of soiling.
9	Female A	Moved to side 1-1/2 inches; urine hit side of urinal, no backsplash. (See note "A".)

NOTE: A. Backflow reduced to 18 to 20 scfm, appears okay.

PARAMETRIC TESTING - SUBJECTIVE COMMENTS

POSITION VARIATION TEST

TABLE XIII

of the test subject. Backward and forward movement had similar effects with distances of one inch or more. It was noted that with female urination, the backward movement resulted in approximately 25 percent of the urine going into the commode portion and being splashed on the user's thighs. In general, the test subjects felt that, in all cases, the positions tested would not normally be used because they felt uncomfortable or unnatural. The consensus was that variation of one-half inch or less in position would be the maximum a user would move without realizing he was not positioned properly and that this range of movement presented no problems.

Diarrhetic Movement. - This test was conducted to determine the ability of the WCS to collect diarrhetic bowel movements. Three male test subjects were utilized to perform this test. Each test subject was given a laxative suppository to initiate a bowel movement. Three bowel movements were accomplished within one hour. After usage by the three test subjects the system was left unexposed to vacuum for one hour to evaluate odor proliferation. No odors were noted. Upon initiation of the vacuum pump, normal vacuum (between 4 and 6 mm Hg) was obtained in approximately ten minutes. In all three cases the loose movement caused some splattering on the transfer tube. The maximum area soiled was approximately a half-inch square. The soiling was generally on the lower portion of the transfer tube indicating that if the anal wash feature, which lengthens the transfer tube, had not been incorporated, there probably would have been less, if any, soiling. It should be noted that the test subjects thought that the air flow, in combination with the looseness of the movements, caused more splattering on the body than a conventional toilet. The subjective comments for this test are recorded in Table XIV.

In addition to evaluating the diarrhetic movement usage, the test volunteers also evaluated a wipe for use during the subsequent 28 man-day tests. The comparison was between a commercial grade, individual tissue sheet type paper and "Kimwipes", a disposable wipe manufactured by Kimberly-Clark Corporation. The test volunteers preferred the "Kimwipes" and these were used as the standard wipe during the 28 man-day tests.

Air Flow Variation Test. - This test series was conducted to determine the maximum air entrainment flows that could be used for urine collection without causing subject discomfort or excessive soiling. These tests were conducted in conjunction with the position variation and 28 man-day tests. It was discovered shortly after testing was initiated that the urinal backflow at the design condition of 35 scfm caused splashing of urine on the upper portions of the seat and on the legs of the female test subjects (noted in the comments in Table XII). The flow was decreased in two steps and a flow of 18 to 20 scfm was found satisfactory, i.e., no splashing of the urine stream occurred. Two of the male test subjects thought the high rear air flow on the scrotum felt a little inhibiting but that they could have gotten used to it.

COMMENT NUMBER	TEST SUBJECT	COMMENT
1	Male B	Prefer "Kimwipes"; soiling on user; movement was "loose".
2	Male C	Prefer "Kimwipes"; no odor emanating from unit; small stain in transfer tube.
3	Male A	Prefer "Kimwipes"; loose movement, runny; small amount of feces on back of inlet tube; also on body.
4	Female A	Prefer "Kimwipes".

PARAMETRIC TESTING - SUBJECTIVE COMMENTS

DIARRHETIC MOVEMENT

TABLE XIV

The main urinal air flow was increased to the maximum capacity of the primary fans (160 scfm) during the 28 man-day testing. No differences were noted by the test subjects during use with the higher flow other than a higher wind noise. The higher flow appeared to cause some liquid droplet carry-over in the liquid/air separator but no liquid was observed being carried over into the filters.

Commode Attitude Test. - The subjective comments for this test are recorded in Table XV. The commode attitude test was conducted to determine the maximum angle the commode could be tilted rearward from the horizontal and still be usable in a "one-g" environment. The tilted commode approach may be utilized in the Space Shuttle to provide capability for waste collection within the vehicle during pre-launch conditions on the launch pad.

The commode was tilted backward from the horizontal in 5° increments from 0° to 25°. The original plan called for testing to be accomplished to a 30° tilt but since the unit was not built for this application it was not safe to go beyond 25° without major changes to the commode to hold the test volunteers. The results indicated that urination would not be a problem with either male or female users through a 25° tilt and it was the opinion of the test volunteers that a 30° tilt would not cause any difficulty. Feces collection was normal through the 15° tilt position. One test volunteer experienced a loose movement at 15° and splattered the lower portion of the transfer tube, but no more than in normal use. At the 20° tilt position no soiling was noted on the transfer tube above the gate valve. However, inspection revealed some soiling in the portion below the gate valve opening. At the 25° tilt position two soil marks of about one-half inch in length and one-eighth inch in width were noted just above the gate valve opening on the rear portion of the transfer tube. The results indicate that soiling will take place on the transfer tube at tilt angles greater than 20° with the present design. However, if the anal wash capability were to be removed and the transfer tube shortened by two inches above the gate valve it appears normal usage would not create soiling.

The test volunteers reported that the centering jets were necessary to attain proper location once the tilt angle exceeded 10° and that without it there would have been major soiling problems. They also thought that a back support was required, not for the whole back but only for the lower portion, because the natural tendency when sitting on the tilted commode was to try and attain a squatting position.

Parametric Test Series Summary. - The parametric test series resulted in a total usage of the Waste Collection Subsystem of twenty-five defecation/urinations and forty-four urinations. Forty-two wipes were utilized and deposited into the commode during this testing. The unit was not emptied after the parametric tests. All feces and wipes were kept in the feces storage/processor and the 28 man-day tests were initiated.

COMMENT NUMBER	TEST SUBJECT	COMMENT
1	Male A	Unit okay at 10°.
2	Male A	Unit okay at 15°.
3	Female A	Unit okay at 10°.
4	Female B	Unit okay at 10°.
5	Male	Unit okay at 15° for use; felt some pressure seated at this angle.
6	Female A	15° unit okay for use; difficult to get on and off.
7	Female B	Difficult to get on and off; urine went into rear because I slid down; need back support at 20°.
8	Female A	Very difficult to get on and off at 20°; otherwise okay.
9	Male B	At 20° okay but needed positioning jet and had to hold on.
10	Female B	25° usable, but can't stay on without help.
11	Male B	25° got slight soiling; quite difficult to stay on.
12	Male A	25° some slight soiling; needed positioning jet; very difficult to stay seated.

PARAMETRIC TESTING - SUBJECTIVE COMMENTS

COMMODE ATTITUDE TEST

TABLE XV

Twenty-Eight Man-Day Tests

The 28 man-day tests were conducted to verify the capacity and ability of the WCS to duplicate a Space Shuttle Mission. The 28 man-day requirement evolved from a preliminary Shuttle baseline for a nominal seven day Shuttle mission with four crewmembers.

The three male and two female test volunteers who performed the parametric tests also were used for the 28 man-day test series. Two tests were conducted. The first was a normal 7-day mission test. The test subjects used the system for seven working days for all eliminations, using wipes for anal and vulva cleansing and depositing the wipes into the commode. The feces were vacuum dried and the commode fecal exhaust gases were "dumped overboard" or in this case into the central exhaust system of the test facility. The second test was the same as the first test in terms of usage of the system by the test subjects. However, this second test was conducted in the "no-vent" operating mode; that is, during vacuum drying the commode exhaust gases were routed through the odor control filters utilized for the entrainment air and then exhausted into the test facility. The main objective of this test was to checkout the feasibility of the "no-vent" operating concept discussed previously in this report. At the completion of the two tests, the unit was cleaned and prepared for further testing.

Twenty-Eight Man-Day Test (Normal Operation)

The 28 man-day normal operating mode test actually was conducted for eight working days. The three male and two female test volunteers utilized the system for a total of twenty-nine defecation/urinations and fifty urinations. A total of one hundred and ninety-nine wipes was deposited into the commode. No anomalies occurred during this test series; the system operated as designed. Some soiling of the commode section occurred, generally two inches or lower in the transfer duct or around the anal wash nozzle. The test volunteers thought that the equalization valve took too long to equalize the commode (approximately 70 seconds) and that this period should be shortened. This can be accomplished by incorporating a larger valve. Specific subjective comments recorded during this test are contained in Table XVI. Instances when the volunteers utilized the system and only recorded the use or checked that everything operated properly are not recorded in Table XVI. At the completion of this test the "no-vent" test was initiated.

COMMENT NUMBER	TEST SUBJECT	COMMENT
1	Male B	Air flow seems to cause soiling on buttocks, unit remains clean. (See note "A".)
2	Female A	Everything fine.
3	Female A	Loose movement, felt it was messy job to clean unit after use. (See note "B".)
4	Male A	Air flow in feces portion still tends to blow feces onto body. (See note "A".)
5	Male A	Air flow feels high in urinal.
6	Female B	No problems with fecal collection.
7	Male B	Rattling sound from commode after second stool entered (before wipes); gone at end. (See note "C".)
8	Male A	Very slight soiling on rear.
9	Female B	Slight backsplash. (See note "D".)
10	Male B	Becoming less inhibited with more usages with respect to defecations.
11	Male C	Air feels warm on anus at end of defecation, cool at beginning.
12	Male A	Positioning jet good but felt normal air flow gave same effect on anus.
13	Male B	Movement slightly loose, slight soiling in transfer duct.
14	Female A	Seemed to feel urinal air flow more but still comfortable.
15	Male B	Loose movement, soiling on unit. (See note "E".)

NOTES: GENERAL - This table only contains specific subjective comments; uses of the WCS in which the volunteers had no comments other than "operation normal" are not included.

- A. Airflow was 25 scfm.
- B. Several 1/4 inch square spots in rear of transfer duct.
- C. Probably due to hard movement.
- D. Did not use positioning device; may have been slightly off in position.
- E. Soiling was generally below 2 inch level and around anal wash nozzle.

28 MAN-DAY TESTS - SUBJECTIVE COMMENTS
(NORMAL OPERATION)
TABLE XVI

Twenty-Eight Man-Day Test (No-Vent Operation)

The no-vent test was conducted with the same five test volunteers as used in the previous tests. Twenty-eight defecation/urinations and twenty-nine urinations were performed during this test. One hundred and forty-one wipes were deposited into the commode. Operating in this mode did not present any difficulty with the unit. No commode odors were noted in the test area with the fecal gases being exhausted through the odor control filters into the test area. One test subject thought the area actually had less general odor during the "no-vent" test than in the previous test series. This was possible because the connection between the vacuum pump exhaust and the facility vent system did have a slight leak back into the test facility. In general, it can be concluded that the "no-vent" concept of operation evolved in the design studies is a workable solution to the requirement. Specific subjective comments for this test are contained in Table XVII. Instances where the volunteers utilized the system and only recorded the use or checked that everything operated properly are not recorded in Table XVII.

It should be noted that one of the female test subjects experienced her menstrual period during this test. There were no problems with unit soiling or usage of the unit by the test volunteer during this time period. The test volunteer did not deposit her absorbant pad in the commode although it is believed that no problem would have occurred if this had been accomplished. This is not expected to be a normal occurrence. Previous studies conducted under the Space Station Prototype program, NASA JSC Contract NAS 9-10273⁽¹⁾, have recommended that female crewmembers have their menstrual period and resultant discharge inhibited by chemical means to avoid potential health problems caused by allowing a discharge in the zero-gravity environment.

Commode Inspection and Cleaning

The commode was not immediately cleaned at the conclusion of the parametric and 28 man-day tests. During the total test period a total of eighty-two defecation/urinations and one hundred twenty-three urinations was experienced by the WCS. In addition three hundred eighty-two wipes were deposited into the commode. The commode was allowed to remain filled without vacuum applied for approximately two months. During this period no odors were noted emitting from the system and no visual evidence of any bacteria growth was noted, indicating the effectiveness of the vacuum drying process.

The unit was found to be approximately 50 percent filled with dried feces and wipes. The filled volume was between 80 percent and 90 percent wipes, the remainder dried feces. The wipes and feces were located somewhat in the center of the storage area and it was initially thought that compacting by the slinger had not been effective. Figure 32 is a photograph taken looking down into the

(1) Swider, J. E. Female Accommodations Concept Selection Report for Personal Hygiene System Study, SSP Document A209, NASA Contract NAS 9-10273, October 197

COMMENT NUMBER	TEST SUBJECT	COMMENT
1	Female A	Slight backsplash on legs; didn't concentrate on position.
2	Male B	Everything good; didn't feel inhibited.
3	Male A	Slight soiling on lower portion of inlet duct; no odors.
4	Male B	Smells better than last week.
5	Male A	Smells better.
6	Male C	Loose movement, soiled me.
7	Male A	Used positioning jet for check only.
8	Male A	Some soiling on back of inlet duct (loose movement).
9	Female B	No odor problem yet.
10	Female A	No odor.
11	Male B	Slight soiling on person only (loose movement).

GENERAL NOTE: This table only contains specific subjective comments; uses of the WCS in which the volunteers had no comments other than "operation normal" are no included.

28 MAN-DAY TESTS - SUBJECTIVE COMMENTS

(NO-VENT OPERATION)

TABLE XVII

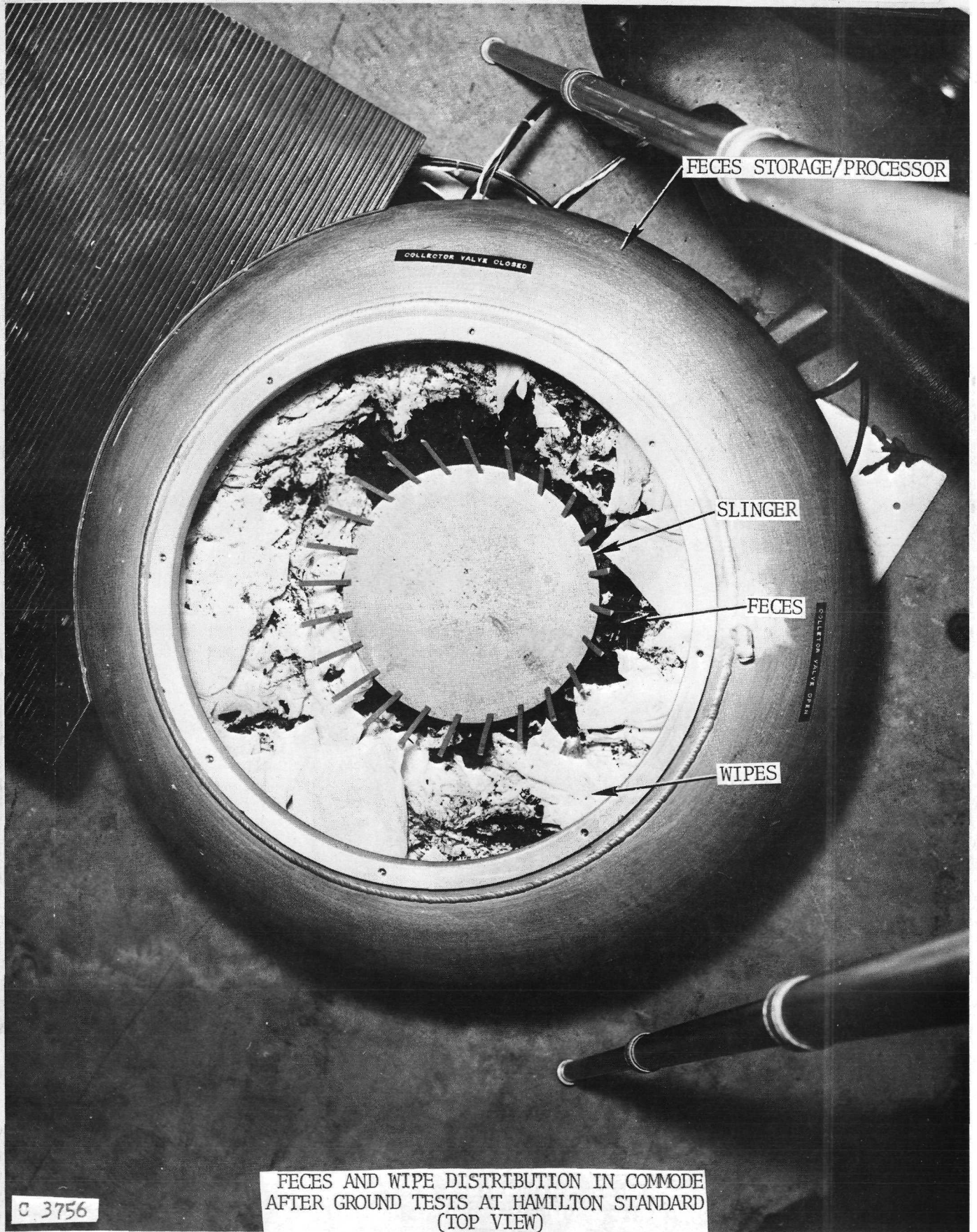

C 3756

FECES AND WIPE DISTRIBUTION IN COMMODE
AFTER GROUND TESTS AT HAMILTON STANDARD
(TOP VIEW)
FIGURE 32

commode and shows the large mass of feces and wipes in the center and lower area of the commode. Figure 33 is a photograph taken from the side and shows the height of the wipes and also the feces that adhered to the commode walls.

Closer inspection of the mixture revealed that the wipes were not loose but stuck together and in some areas attached to the wall. While the fecal matter was not totally mixed in, some feces were found mixed and a considerable amount of fecal matter was still stuck on the walls as illustrated in figure 33. It is believed that in moving the unit from the test area to the cleaning facility the jostling loosened both the feces and the wipes and this is why a large amount of the mixture was found in the center of the storage area.

The feces were found to be well dried. The slinger had effectively broken up the individual stools as the pieces of fecal matter were hard and flat, similar to rust chips. The largest individual chips appeared to be on the order of one inch square and one-eighth inch in thickness. Larger pieces were found which consisted of many smaller pieces and when disturbed, generally flaked apart into smaller chips.

Although the wipes were found stuck together, the majority of the wipes were not shredded. In general they were torn and partially ripped up but actual shredding did not appear to have taken place. The wipes were evaluated with other more typical toilet tissue. It is believed the "Kimwipes did not weaken enough when wet to permit them to be shredded, A commercial toilet tissue, Scott's Soft-weave, was utilized for the subsequent University Testing.

Inspection of the unit found the slinger and air screen area to be very clean. Figure 32 shows the cleanliness of the slinger while figure 34 depicts the air outlet screen. Figure 34 also shows the soiling in the inlet diffusion section of the commode. The cleanliness of the screens indicates that the slinger efficiently dispersed the feces and wipes and that they adhered onto the walls, otherwise evidence of feces and paper would have been found on the air outlet screen.

The unit was cleaned with a water hose. The commode was tipped up on its side and the entire inside of the commode sprayed. Water pressure was adjusted to approximately 30 psig and the water temperature was in the range of 110°F to 120°F. The water spray effectively cleaned the inside of the commode. No rubbing with brushes or wipes was required. It should be noted that the surface on the inside of the commode was aluminum in a machined condition. There were no special finishes added to enhance cleansing. The effectiveness of the cleansing method adds confidence to the probability of developing an effective in-place cleansing method for the commode. After cleansing, the unit was prepared for the University testing.



DRIED FECES ON FECES
STORAGE/PROCESSOR WALL

WIPES

SLINGER TINES

FECES STORAGE/PROCESSOR

FECES AND WIPE DISTRIBUTION IN COMMODE
AFTER GROUND TESTS AT HAMILTON STANDARD
(SIDE VIEW)
FIGURE 33

C 3754

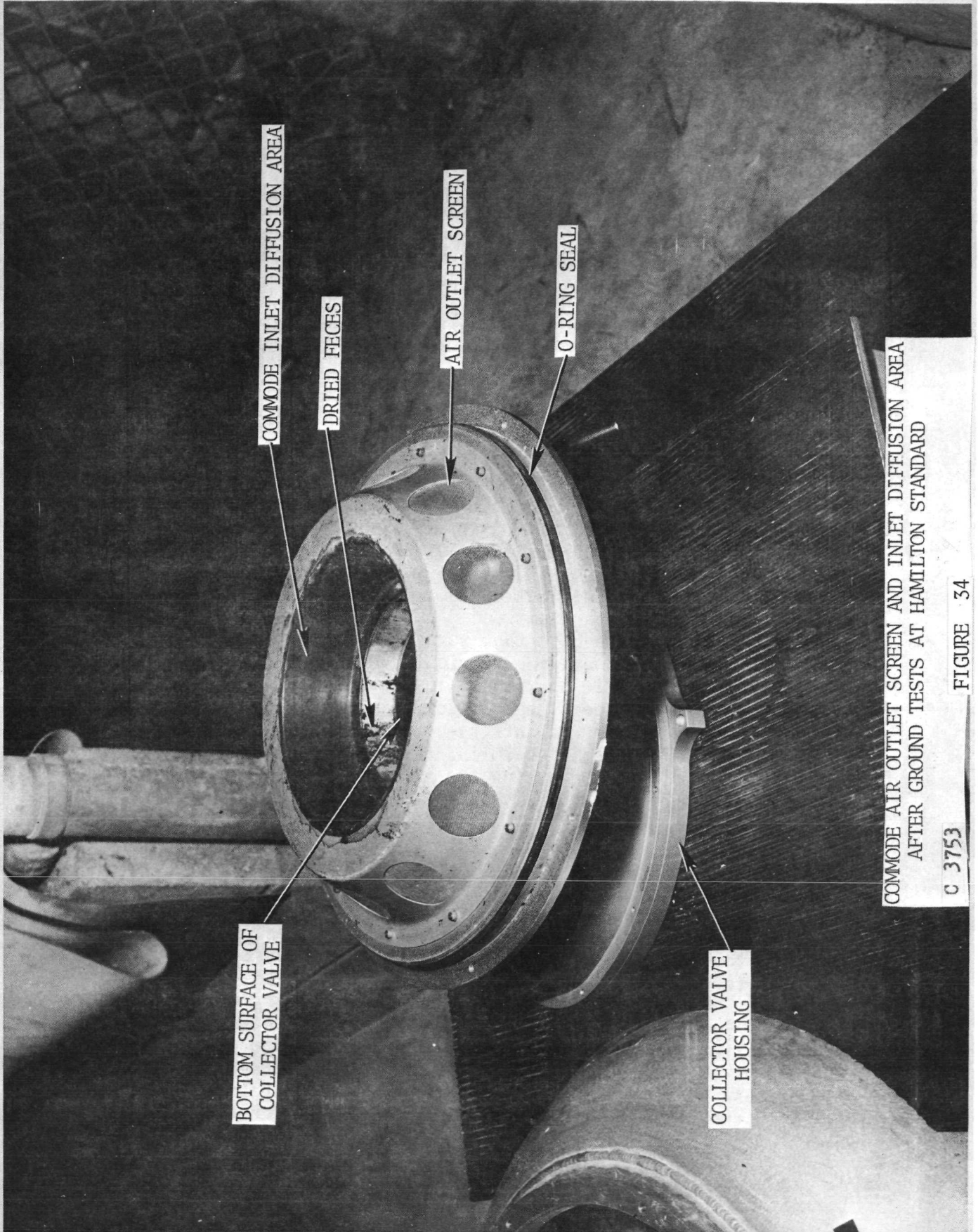

COMMODE AIR OUTLET SCREEN AND INLET DIFFUSION AREA
AFTER GROUND TESTS AT HAMILTON STANDARD

C 3753

FIGURE 34

University Testing

The University Testing was conducted at the University of Connecticut Health Center in Farmington, Connecticut. Six male and six female medical students volunteered to utilize the WCS for a two week period during normal working hours, one week utilizing wipes for anal cleansing and a second week using the anal wash. The unit was installed in a lavatory (figure 35) at the Health Center similar to the arrangement utilized at Hamilton Standard during the previous test series. The unit was set up in the normal operating mode both weeks; that is, the fecal gases were vented external to the test area. The objective of utilizing the students for WCS testing was to obtain an evaluation of the WCS by individuals not connected in any way with the WCS program.

Anal Wipe Test

The anal wipe test was conducted first, with sixty-one uses of the WCS obtained. Of the sixty-one uses, forty-seven were defecation/urinations and the remainder urinations. A total of two hundred eight-three tissue wipes was deposited into the commode. It should be noted that according to the data sheets one usage required forty-eight tissue wipes.

In general, the students had much more trouble with soiling and urine splashback than had been experienced during the previous testing of the commode. It might have been that some students at first did not pay attention to the procedures and were insufficiently motivated to try to understand the entire system and how it operates. Inspection of the data sheets revealed that those test volunteers who carefully followed procedures, used the centering jet and had concise comments, generally had no problems with the system other than occasional soiling during a very loose movement. Because of the various comments received during the first two days of testing a second training session was held with the volunteers on the third day of testing and this training did appear to help later test operations.

The major anomalies experienced during this phase of the test were forgetting to open and close the collection valve, partially defecating into the urinal and putting paper into the urinal. There were some complaints of the noise being somewhat inhibiting. The complaint heard most often during this phase of the testing was that the air flow felt very cold. In discussions with the test subjects they expressed the opinion that the most inhibiting aspect was the anal air entrainment flow although the urine entrainment flow also felt cool. The test subjects thought that the cold temperature of the air in the test room - the heat was not operating and the room temperature averaged 60°F - was creating the problem. Specific subject comments for this portion of the testing are presented in Table XVIII. Instances when the volunteers utilized the system and only recorded the usage or checked that everything operated properly are not recorded in Table XVIII.

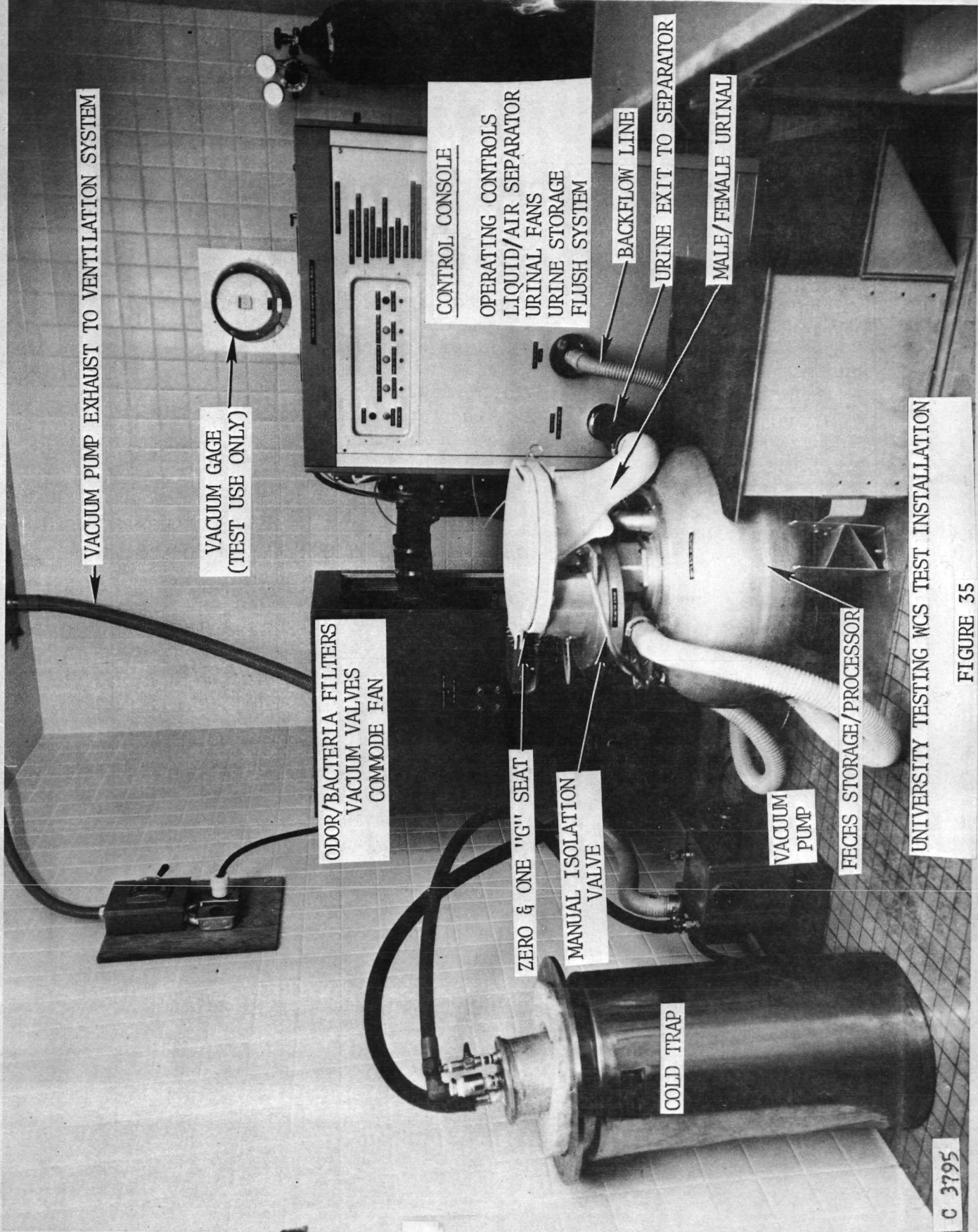

FIGURE 35

C 3795

COMMENT NUMBER	TEST SUBJECT	COMMENT
1	Female 6	Good - only urinal utilized.
2	Female 2	Seat is cold; some splashing in vulva area and inside of thighs; too much noise; got seat dirty with urine on front top; feces on some of rear collector area. (See note "A".)
3	Female 4	Slight back splashing, back of legs. (See note "A".)
4	Male 4	Urinal airflow - too much, too cold; fecal soiling rear of collector hole. (See note "B".)
5	Male 1	Urinal airflow cold; fecal collection soiling on unit.
6	Female 3	Unit soiled at present; also wipes tend to stick to rear and seat and must be sent down by hand.
7	Female 2	Splashing on vulva due to airflow, most unenjoyable. (See note "A".)
8	Male 6	It was cold.
9	Female 1	Seat soiled from wipes; toilet rocks.
10	Female 2	Splashing in vulva inside of thighs. (See note "A".) Seat soiled with feces. (See note "C".)
11	Male 3	Fecal material in urinal, also where scrotum rests. (See note "C".)
12	Male 1	Soiling on unit in front fecal collection area.
13	Female 3	Dislike limitation on wipes; also active airflow is cold.
14	Male 5	Urinal airflow cold and too much.
15	Female 2	Splashing on vulva. (See note "A".)

UNIVERSITY TESTS - SUBJECTIVE COMMENTS
ANAL WIPE TEST

TABLE XVIII

COMMENT NUMBER	TEST SUBJECT	COMMENT
16	Male 2	Stood up to urinate - no problem.
17	Male 4	Airflow was acceptable and good in terms of volume (almost too much so) but cold with degree of chill. Note: Flow unchanged from initial use
18	Male 2	Air was too cold.
19	Female 4	Smells in here! (See note "D".)
20	Male 1	Airflow still cold.
21	Female 1	Airflow cold.
22	Female 2	Airflow cold; tends to reduce the impulse to defecate.
23	Male 5	Difficult to feel positioning jet with other flows on.
24	Male 2	Airflow cold.
25	Male 3	Had very wet defecation - used 48 wipes. No soiling on unit.
26	Male 4	Airflow cold.
27	Male 1	Soiling on posterior wall of collector.
28	Female 1	Seat vibrating producing sensation not very conducive to elimination.
29	Female 2	Airflow too cold - procedure is becoming less alien with time.
30	Female 3	Freezing today.
31	Female 4	Cold - got urine splashing today. (See note "A".)
32	Female 3	I have trouble waiting one minute for system to be ready. I like this less and less even though the mechanics are becoming less complicated.

UNIVERSITY TESTS - SUBJECTIVE COMMENTS
ANAL WIPE TEST

TABLE XVIII (Continued)

COMMENT NUMBER	TEST SUBJECT	COMMENT
33	Female 2	Still getting splashed but not as bad if I sit further forward. (See note "A".)
34	Female 1	Got urine splashing; tried to use centering jet and missed urinal; moved forward and had no difficulty.
35	Male 3	Cold.
36	Female 5	Cold.
37	Female 1	Paper in urinal.
38	Female 2	Fecal soiling posterior wall of chute.

NOTES: GENERAL - This table contains specific subjective comments; uses of the WCS in which the volunteers had no comments other than "operation normal" are not included.

- A. Centering jets were not used. Believe subject was not positioned properly.
- B. During first week of test, heat was not adequate in the test facility. Temperature was 60°F as mentioned in discussion. This prompted "cold air" comments.
- C. Discovered someone had defecated in urinal and on seat. Never discovered who or why.
- D. Exhaust line from vacuum pump had come off vent. It was replaced the next day.

UNIVERSITY TESTS - SUBJECTIVE COMMENTS
ANAL WIPE TEST

TABLE XVIII (Concluded)

Anal Wash Testing

The anal wash test was conducted during the second week of the test period. A total of fifty-four uses of the WCS resulted during this period. Of these, forty-one were defecation/urinations and thirteen were urinations. The test volunteers' reaction to the anal wash system was not favorable. Initially the water pressure was set at 20 psig; 1.6 pounds of water at a temperature of 115°F were used for the anal cleansing in a time span of 30 seconds. This established condition represented the anal wash configuration previously tested and found acceptable. Test subject comments on the anal wash at this condition varied from "water pressure too high," to "acceptable". At the same time some subjects thought the wash time was too short because it was ineffective in cleansing. In order to eliminate the "high pressure" complaints the water pressure was lowered midway through the test from 20 psig to 10 psig; the amount of water utilized was kept constant and the length of wash increased to approximately 50 seconds. The pressure complaints stopped but in many cases the water was found to be ineffective in accomplishing cleansing and the wash time still was thought to be too short. The students also complained about the water temperature being first cool and then warm. This condition existed because of the water accumulation in the lines between the water heater and the commode having cooled down between uses. In general, the anal wash test results indicated the need for additional testing with various combinations of water pressure, temperature and spray patterns to actually determine the most acceptable anal wash system configuration. It should be noted that the anal wash water must be heated as close to the spray nozzle as possible or else some method must be found to isolate the cold water, so the user only feels warm water on the anus.

The students also disliked the lag time in the air heater but most of them felt the warm air was pleasant on the anus. Temperature settings for air drying varied between 80°F and 120°F. The most popular setting was in the 115°F to 120°F range. Drying times varied from 30 seconds to 7 minutes. The combination of lag times and time required to dry, prompted several comments on the time required being too long. It would appear that if the anal wash system were to be utilized a heater would be required which could provide "instant warm air". A temperature in the 115°F to 120°F range would seem to be an acceptable operating temperature. It should be noted that there were fewer comments about cold air during this test because the heat had been turned on in the test room.

In addition to the anal wash, a water rinse for the fecal collection tube above the gate valve was used during this portion of the test. The water pressure source was the same as for the anal wash nozzle. One pound of water was utilized for the rinse at both pressure settings. It was observed that at the 20 psig pressure setting the rinse helped keep the fecal collection tube slightly cleaner than during the wipe test, but at the 10 psig pressure the

rinse was ineffective. This indicates that the two washes may require different pressure sources and additional optimization of a wash manifold also may be necessary. Table XIX presents the specific subjective comments obtained during the anal wash portion of the testing. Figure 36 depicts the WCS test installation with the anal wash kit.

The test volunteers were requested to provide a general critique of the system and to express a preference for anal wash or wipes. All of the students thought the system was acceptable for use either in a one-g or a zero-gravity environment. They disliked that it took more time to use and required a more complex operating procedure than a standard commode, but still found it usable. The students all definitely preferred the wipes to the anal wash system. Their general opinion was that the anal wash made the whole process too long and complex to be practical. The general comments on the test program from the student volunteers are contained in Table XX.

Commode Inspection

The commode was opened and an inspection of the interior made prior to movement of the unit from the University facility. The distribution of the stored wastes was the most prominent feature inside the collector. The total occupied volume was approximately 40 percent, and the volume of paper was approximately 90 percent of the occupied volume. A mixture of paper and feces was distributed fairly uniformly in the bottom of the collector except for two bare areas approximately 120° apart where no paper was accumulated. No obvious reason is apparent for the bare spots. The mixture of paper and feces appeared homogenous. This mixture was not located on the impact area of the wall, but appeared to have settled into the trough at the bottom of the collector. Despite the apparent tendency to settle, the mixture had dried into a rigid matrix capable of resisting abusive handling. Figure 37 depicts the aforementioned bare areas and the feces/wipes distribution in the lower portion of the commode.

A definite feces impact band was clearly visible around the entire collector perimeter thus indicating a uniform distribution pattern from the slinger. This band was located above the bulky paper areas suggesting the paper and feces mixture at the bottom had settled during the first week of testing. The fecal band was made up of multiple fecal buildups and the buildups had good adhesion properties with each other and with the collector wall, as evidenced by the distribution band and the fact that it had not been distributed by movement. Shredded wipes (10-20 percent by volume) were mixed in with the feces representative of the use of vulva wipes by the female test volunteers. Figure 38 depicts the band of feces and wipes.

There was a streamer (3 plies, 6 inches long) of toilet paper tangled in the slinger tines. Although a prominent feature, the streamer is not inconsistent with previous slinger testing where some paper would not become

COMMENT NUMBER	TEST SUBJECT	COMMENT
1	Female 3	Soiling on individual. Anal wash left me dirty and uncomfortable. Bad news, better luck next time.
2	Female 4	Water pressure too high; didn't clean; too short a wash.
3	Female 3	Feces chamber very soiled.
4	Male 4	I don't think cleaning is effective.
5	Male 1	Drying for 3 minutes too long - at 100°F setting.
6	Female 2	Temperature setting on 115° felt very cold; don't think air heater came on. (See note "A".)
7	Female 1	Water pressure too high! Air heater set on 115°F felt very cold, took longer than 3 minutes to dry. Also positioning jet great for fecal collection, but useless for me in urine collection. Had to move forward.
8	Female 6	Did not clean feces.
9	Female 2	The anal wash did not clean effectively at all! Heater lag time is too long. First its cold, you crank up the thermostat and fry 5 minutes later!
10	Female 1	120°F drying air very comfortable; 5 minute drying time too long. Water temperature slightly high but better than being cold.
11	Male 1	Slight soiling; posterior wall of unit didn't clean effectively.
12	Female 3	Air flow more comfortable now.
13	Male 5	At 88°F, took 7 minutes; incomplete drying. It gets easier to use.
14	Female 2	Didn't clean effectively. Heater didn't heat up in time to dry effectively.
15	Male 3	Fair cleaning.
16	Male 4	Unit smells. (See note "B".)
17	Male 5	Foul odor from unit. (See note "B".)

NOTES: General - This table contains specific subjective comments; uses of the WCS in which the volunteers had no comments other than "operation normal" are not included.

- A. Check was made. Apparently not sufficient time allowed for heater warm up.
- B. Odor was reported on last test day. Upon inspection found that someone had defecated with valve closed and had not cleaned anal wash exit area. It had wet feces.

UNIVERSITY TESTS - SUBJECTIVE COMMENTS

ANAL WASH TEST

TABLE XIX



ANAL WASH CONSOLE
OPERATING CONTROLS
AIR HEATER
WATER HEATER
WATER SEPARATOR

AIR LINE TO
ODOR FILTERS

SEAT COVER

ZERO & ONE "G" SEAT

URINE EXIT
TO SEPARATOR

HEATED AIR
INLET TO
COMMODE

BACKFLOW LINE

VACUUM LINE

UNIVERSITY TESTING WCS TEST INSTALLATION
WITH ANAL WASH KIT

C 3797

FIGURE 36

TEST SUBJECT	COMMENT
Male 1	<ol style="list-style-type: none"> 1) Anal wash is ineffective in present configuration; spray patterns and pressures need to be worked on; water and drying air have to be made more responsive; starting cold and then getting hot does not help overall acceptance; consequently I prefer wipes over the anal wash. 2) Positioning jet was effective for me. However, I think higher pressure is needed to allow use when entrainment flows are on. 3) I had no problems with anal wipe test other than some unit soiling on loose movements that required manual cleanup that could be a problem. 4) Controls seemed ok.; would be better if wait for start was shorter and if it could be made automatic. Adding anal wash does take an awful lot of time, actually too much.
Male 2	<ol style="list-style-type: none"> 1) I prefer wipes - anticipating GI distress on occasion - I think wipes can accurately cover more surface. Also, the wash process - the drying - is time consuming. 2) I think the unit is ok.; really pretty much natural except for button pushing.
Male 3	<ol style="list-style-type: none"> 1) Prefer wipes to wash - too complicated, time too long for wash - didn't clean. 2) Thought system was adequate. I'm not crazy about it!
Male 4	<ol style="list-style-type: none"> 1) Rather wipe system. 2) Test - machine proved adequate. Exceptions - temperature for air in urine collection - pressure change when system is turned on. When subject seats himself, then vacuum off light goes on - is somewhat disturbing.

UNIVERSITY TESTS - SUBJECTIVE COMMENTS
GENERAL

TABLE XX

TEST SUBJECT	COMMENT
Male 5	<ol style="list-style-type: none"> 1) I prefer the anal wipe routine because it was a lot more effective. If one were to use the anal wash for two weeks he might have a hard time walking around. 2) In general the system can be somewhat inhibiting. When the air was cold (first week) defecation was a real problem. The only other trouble was the noise. Its hard to relax if you think that the system may not be functioning correctly.
Male 6	No comments received.
Female 1	<ol style="list-style-type: none"> 1) Anal wash versus wipe <ol style="list-style-type: none"> a) - Anal wipes are more effective than wash - after anal wash I would walk out of unit and realize I wasn't thoroughly clean. Perhaps anal wash should be doubled in time, larger diameter stream since whole rear gets wet anyway. b) - Convenience - anal wash and air dry is too time consuming (5 minutes). c) - Comfort - only discomfort was varying temperature of air flow and anal wash, and pressure of anal wash which one can get used to (unless there are hemorrhoids present). d) - Acceptability - unacceptable <ol style="list-style-type: none"> 1) odor! when present - bad! 2) would be more acceptable for me if I didn't have to change seating positions for urine and fecal collection. (See note "A".) 2) Overall impression: The unit didn't work that well for me - changes which would help for me: <ol style="list-style-type: none"> a) - urine collection outflow extended posteriorly (see above). b) - less pressure on anal wash, larger stream diameter, longer duration of wash, constant temperature (rather than cold start and scorching end). c) - better air flow - more constant temperature for anal dry. d) - eliminate air flow (anal) which is on while one is in the process of elimination. e) - deodorize unit.

NOTE: A. Upon investigation it was determined that this particular volunteer still positioned improperly by positioning the vulva over the centering jets for urination, thereby ending up too far to the rear.

UNIVERSITY TESTS - SUBJECTIVE COMMENTS
GENERAL
TABLE XX (Continued)

TEST SUBJECT	COMMENT
Female 2	<ol style="list-style-type: none"> 1) Anal wash is ineffective. On all occasions the use of wipes in addition to the wash has been necessary. Anal wipe is acceptable. 2) The whole test proved to me that once you get accustomed to the unit, elimination is easy. The main difficulties still present in the unit are: <ol style="list-style-type: none"> a) the lag time to bring drying air temperature up to the set temperature. b) the ineffectiveness of the anal wash.
Female 3	<ol style="list-style-type: none"> 1) Prefer wipes 100:1. 2) This whole procedure stinks! The wash is vile; I would recommend prepackaged moist wipes as an alternate. 3) As a method of urine collection for females in zero-g this seems adequate.
Female 4	<ol style="list-style-type: none"> 1) Anal wash takes too long and is ineffective as far as cleaning is concerned. 2) Urine collection system ok as long as air flow not too high; otherwise causes splashing.
Female 5	<ol style="list-style-type: none"> 1) Urine collection was ok. 2) Fecal collection - I found the whole set up too noisy and inhibiting to enable fecal collection.
Female 6	<ol style="list-style-type: none"> 1) Anal wash did not work effectively and was not comfortable. The toilet paper was much better. 2) In general, unit was very convenient, functional and acceptable.

UNIVERSITY TESTS - SUBJECTIVE COMMENTS
GENERAL

TABLE XX (Concluded)

shredded but would remain in the slinger tines. In each instance the next defecation would clean the tines and provide a greater packing influence on the paper due to the momentum of the heavier feces.

Figures 37 and 38 both show the wipes entangled in the tines. The shredding action of the tissue was improved in the University test series where the "Scott's Soft-weave" tissue was used in place of the "Kimwipes". The larger amounts of tissue used for anal wipes were partially shredded and torn and did not adhere well to the impact area of the collector. It also was noted that the test volunteers did not follow instructions and obviously put in sheets of wipes larger than individual pieces and this also degraded the shredding and adhesion capability.

The action of the paper and feces when large amounts of paper are present emphasizes a potential problem for zero-gravity operation. It is obvious that in one-g operation the adhesion property of the feces is not enough to hold the total mixture to the commode walls for drying and the mixture slides down into the trough at the bottom of the collector. The tests have shown that the mass does dry and once dry does stay together. If the paper/feces mixture does not adhere to the collector wall in the zero-gravity environment, the dried mixture might float free within the collector and might be continuously acted upon by the slinger.

One potential solution to the problem discussed above would be to use prewetted individual wipes and to control the amount of wipes used. The test results indicate that lack of adhesion is not totally due to the presence of wipes but to the volume of wipes. Prewetting would reduce the number of wipes required and also would provide better adhesive qualities. The wipes and feces adhered well to the wall during the anal wash test. Therefore, it is expected that if they are capable of wall-adherence in one-g prior to drying they should adhere in zero-gravity where there isn't any force acting to move them. Another potential solution would be to create a rougher interior surface in the commode and possibly even have small protrusions which would impale the wipes and assist adhesion to the wall. Testing should be accomplished in the future to investigate this area of concern and potential solutions.

The slinger base was found exceptionally clean indicating possible water leakage from the anal wash cycle into the collector. Any leakage must have been minimal because during other tests (1), where substantial leakage was present, the stored feces were wetted and had slid into the bottom of the collector. The distribution band previously described indicates that leakage of this type was minimal. The inlet diffusion section of the collector was quite soiled as can be seen in figure 39. This area was exposed to the vacuum and the feces were fully processed. As can be seen in figure 39 the outlet filter of the collector was free of feces or paper and was remarkably clean, indicating that the strategic location of the outlet is satisfactory for avoiding slinger impacts and splatterings.

(1) Passalacqua, J. Test Report Two Stage Waste Management System, HSD Report, SSP Document No. 63, Contract NAS 9-10273, 1970.

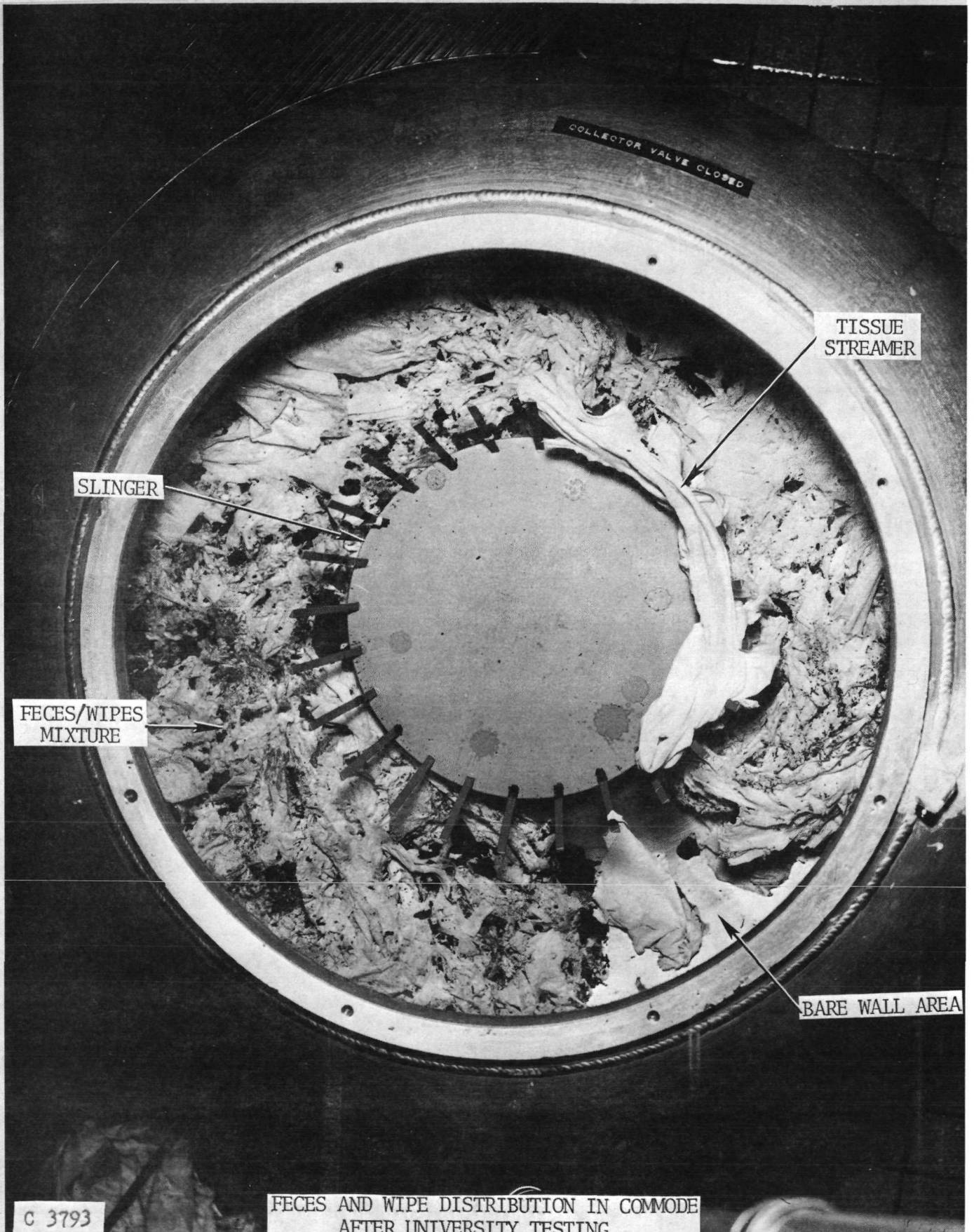

FECES AND WIPE DISTRIBUTION IN COMMODE
AFTER UNIVERSITY TESTING
(TOP VIEW)

FIGURE 37

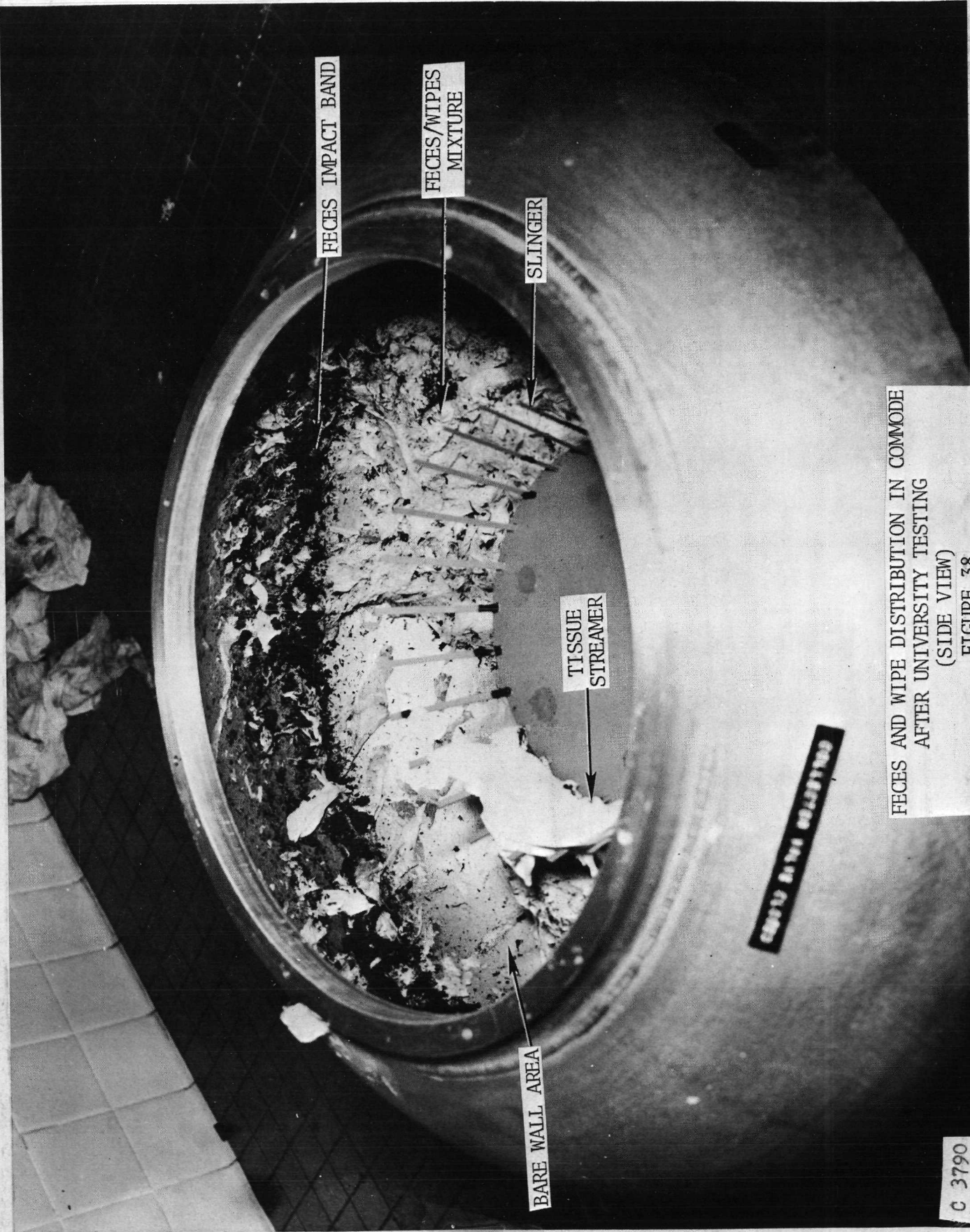

FECES AND WIPE DISTRIBUTION IN COMMODE
AFTER UNIVERSITY TESTING
(SIDE VIEW)
FIGURE 38

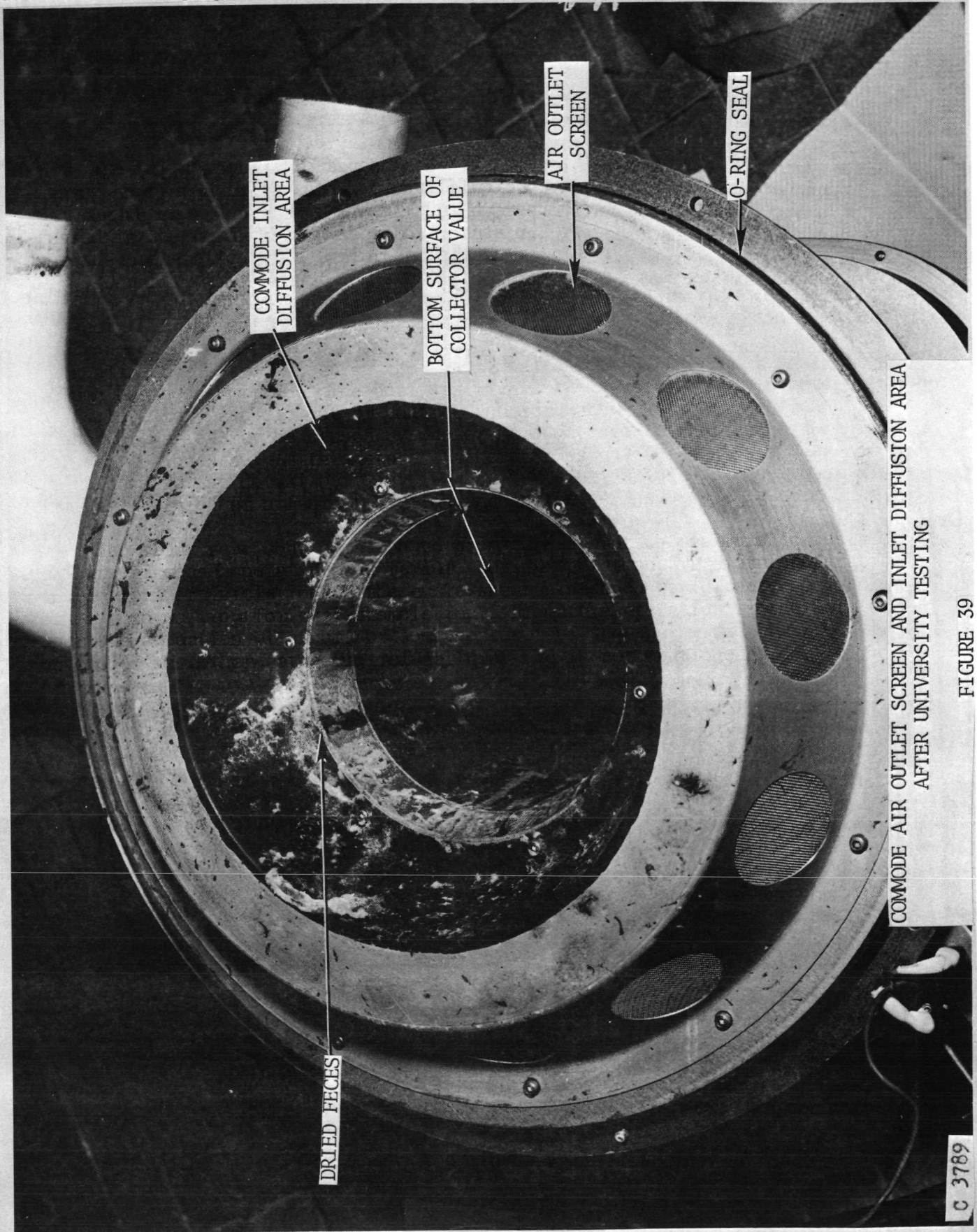

COMMODE AIR OUTLET SCREEN AND INLET DIFFUSION AREA
AFTER UNIVERSITY TESTING

FIGURE 39

C 3789

The University test series emphasized the necessity of having a screen filter in the urinal air entrainment line upstream of the liquid/air separator. Inspection of the filter revealed the following debris: two toilet tissues, one early in testing, one later as surmised by the fact that considerable hair was found between the tissues; a one-half inch diameter fecal stool; many strands of pubic hair trapped in the screen and tissue; and a piece of cloth two inches long, five strands wide, probably from someone's clothing.

The commode was cleaned without difficulty using the same method previously employed after the ground test series at Hamilton Standard. After cleaning the entire Waste Collection Subsystem it was prepared for delivery to the NASA, Johnson Space Center.

RELIABILITY

The reliability effort conducted as part of the WCS development activity was concentrated in two areas. A fail operational - fail safe design study was conducted as part of the design study activity and the results are discussed in the design study section of this report. The other pertinent activity was the preparation of a Failure Mode and Effects Analysis.

The Failure Mode and Effects Analysis is contained in this report as Appendix C. The analysis covers only zero-g operation of the system; in a one-g environment, fewer failure modes would occur. Since the failure mode description also covers the effect on the functional assembly, the functional effect column has been omitted. The analysis treats the several possible categories of failure for each element of control and for each functioning component. These categories may be caused by one or more detailed circumstances within or between components. At this stage of the WCS design, the analysis does not reach down to the detail part level. However, the analysis can serve as a preliminary version of a Fault Detection and Isolation Analysis.

The study gave consideration to premature operation, failure to operate, failure to cease operating and failure during operation. Premature operation in the form of initiation of the cycle when unintended would cause no problem other than waiting for cycle completion. Premature operation in the form of spurious actuation of a part or component out of sequence would have the effect of one of the other categories of failures and is not mentioned separately.

SYSTEM SAFETY

The WCS development unit considered overall safety in the actual design of the unit, which was designed fail-safe. Personnel are protected against vacuum by a user operated manual gate valve. If the user should ignore procedures and try to force the valve open when vacuum is in the commode there is sufficient force present to prevent this from occurring until the pressure in the commode is up to 500 mm Hg, as established by test. At this point, even if the valve were to be opened, the air entrainment openings in the feces transfer duct below the seated user would provide sufficient opening to allow air into the commode without the user feeling any pressure differential.

Personnel are protected against fracture of rotating elements both by low stresses and by containment. Pressure vessels are limited in pressure input and are protected by relief valving. Gas velocities are limited by design. Bacteria are killed or inhibited. The electrical system is protected by fusing and all individual pieces of equipment are grounded.

Review of the WCS design and operation will verify that a safe system has been produced.

INTERFACE REQUIREMENTS

The interfaces required to provide for the operation of the WCS Development Unit are depicted in the schematic of figure 27. The operation of the basic system without the Anal Wash or No-Vent Kits requires six external interfaces:

- Vacuum source
- Nitrogen supply
- Water supply for biocide/flush water fill
- Power supply; 60 Hz, 115 VAC
- Urine/water drain
- Air discharge

The addition of the Anal Wash Kit requires a separate source of power and water and an additional drain connection. The power selected for the WCS Development Unit components is standard 60 Hz, 115 volt AC power, to provide the flexibility for testing at various sites.

The floor area required for the WCS Development Unit including its two add-on kits is 96 inches by 92 inches. The basic unit without the add-on kits requires an area of 80 inches by 60 inches. The detail data pertaining to the installation and interface connections required for the WCS Development Unit are specified in detail in the "Waste Collection Subsystem Familiarization and Operations Manual", of Contract NAS 9-12150.

Except for the number and type of interfaces specified, the development unit was designed and manufactured for ground and aircraft testing and test flexibility. Other than in the basic configuration, the WCS Development Unit is not representative of a system designed for space flight, and the total subsystem should not be construed as such.

The following interfaces are presently considered as required for an actual flight installation of the WCS.

- Vacuum line to exterior of vehicle - one inch diameter, maximum.
- Gas supply - pressure range required - 20-40 psia.
- Water supply - 2 pounds per man-day required; maximum flow rate, 10 pounds per minute.
- Power supply - 200 VAC, 400 Hz, 3 phase.
- Waste liquid drain line to exterior of vehicle.

It is estimated that a flight commode assembly will be 25 inches in diameter by 30 inches in height and volume allocations within a vehicle should reflect those dimensions. It is expected that the ancillary components will be dispersed throughout the vehicle as required by the overall vehicle system and an accurate volume assessment is presently not attainable.

**Hamilton
Standard**

U
DIVISION OF UNITED AIRCRAFT CORPORATION
A®

SVHSER 6182

APPENDIX A

OPERATIONAL REQUIREMENTS

FECAL COLLECTION

A) Commode shall have the capacity to contain the following:

42 man-days of feces:	total design weight	22.68 lbs.
	water weight	<u>15.54 lbs.</u>
	solids weight	7.14 lbs.

42 man-days of wipes:	total design weight	1.344 lbs.
	fecal elimination wipes	<u>.672 lbs.</u>
	female vulva wipes	.672 lbs.

42 man-days of vomitus:	total design volume	<u>6,300 cc</u>
	volume per occurrence	900 cc

B) Feces shall be separated at the anus and transferred to storage/processor via air entrainment.

Minimum Entrainment Flowrate 10 cfm
@ 14.7 psia and 70°F

C) Slinger/shredder design must shred wipes as well as spread feces evenly about the storage area.

D) Fecal collection hole and transfer duct shall be four inches in diameter. The design shall insure that this is adequate for collection and movement of feces without excess soiling on surfaces.

E) Safety

1) An indicator light on the control panel shall show when commode is on vacuum.

2) All electrical areas shall employ normal safe design i.e. fuses, etc.

F) There shall be no time limit between eliminations other than equipment cycling. Maximum number of eliminations in succession should not exceed a normal mission day's amount (9) to allow for normal vacuum drying.

G) Time to vacuum dry a nominal day's eliminations should not exceed 12 hours; this is a design objective as it is dependent on the vacuum system used for ground testing.

H) The fecal collector shall incorporate a gas locating jet to allow proper location of the anus over the collection hole.

Locating jet minimum pressure - 20 psig
Time - Momentary - will be controlled by user

- I) The commode shall incorporate filter screens internally to minimize particles that will exit to vacuum or through the fan to the odor control cartridge and bacteria filter.

URINE COLLECTION

- A) The urinal shall accommodate both male and female crewmembers.
- B) Intimate contact with urinal parts shall not be permitted for collector operation.
- C) The back edge of the urine collector shall start no more than 2.0 inches from the center of the fecal collection duct to alleviate the possibility of large quantities of urine entering the feces storage/processor.
- D) The urine shall be entrained and moved to the storage tank utilizing air entrainment.
- E) The entrainment scheme shall provide an entrainment flow velocity of 40 ft/sec in the female vulva area.
- F) The entrainment flow shall be of sufficient magnitude to provide a flow velocity of 30 ft/sec to move urine and flush water along the urinal walls.
- G) Minimum fan flow capacity for the urinal shall be 200 cfm @ 14.7 psia and 70°F. Note: Lower flow rates are expected to be used but the capacity will be provided since this is a development unit.
- H) Fluid/air separation shall be accomplished by the use of a Vortex type liquid/air separator. Separated fluid shall be pumped to the storage tank; the air shall pass through the odor control filters to the cabin.
- I) The urinal shall be cleaned by a rinse of water and biocide; amount of fluid used per rinse - .80 lbs - maximum.

Rinse solution flow rate - 3.2 lbs/min - minimum

- J) Rinse solution shall be kept in a supply tank with a minimum capacity of 48 hours for a six member crew. Total Tank Capacity - 56.8 lbs.
- K) Rinse cycle shall be initiated by a manually operated switch and shall shutdown automatically.

- L) Urine and rinse fluid shall be stored in a tank with 48 hours capacity for a six member crew.

Urine in Tank	55.32 lbs.
Rinse Solution in Tank	56.8 lbs.
Total Tank Fluid Capacity	<u>111.12 lbs.</u>

SEAT DESIGN

- A) The seat design shall be adequate for use in one "g" and zero "g" environments.
- B) The seat design shall support the ischial tuberosities of the crew-member.
- C) The seat design shall allow access for wiping and still provide sealing to allow effective entrainment and contaminant control.

ODOR CONTROL

- A) All air flow through the commode or urinal shall pass through the odor control system prior to exit to the cabin.
- B) A bacteria filter shall be provided in the cabin exit line to remove bacteria in the air stream; it shall have a minimum seven-day, 42 man-day capacity.
- C) An odor control filter shall be provided in the cabin exit line, tentatively Purafil, to eliminate odors; it shall have a seven-day, 42 man-day capacity.

APPENDIX B

SAMPLE TEST SUMMARY DATA SHEET

I. GENERAL DATA

1. Test Subject:
2. Time of Collection A.M./P.M.
3. Date of Collection
4. Room Temperature
5. Type of Test

II. URINE COLLECTOR DATA

6. Air Flow Rate scfm; comfortable uncomfortable
7. Collection time minutes
8. Flush Water Quantity
9. Flush Water Flow Rate
10. Flush Water Pressure

General Subjective Comments

11. Backsplash
12. Soiling
13. Comfort (seat, pressure points, positional variance, etc.)
14. Access for vulva wiping (females only)
15. Other

III. FECAL COLLECTION DATA

A) Wipe Cleansing

16. Number Used
17. Sequence ; Satisfactory Unsatisfactory
18. Air Temperature Setting Number ; F(C).

Note: Adjust control to individual subject comfort level.

20. Collection Time

General Subjective Comments

21. Soiling

22. Comfort (seat, pressure points, positional variance, etc.)

23. Access for wipe cleansing

24. Access for wipe disposal

25. Other

B) Douche Cleansing

26. Air Temperature Setting Number ; °F(C).

Note: Adjust control to individual subject comfort level.

27. Air Flow Rate scfm; comfortable, uncomfortable

28. Drying Time minutes

29. Water Temperature ; satisfactory, unsatisfactory

30. Water Flow Rate scfm; satisfactory, unsatisfactory

31. Water Pressure ; satisfactory, unsatisfactory

32. Water Quantity ; satisfactory, unsatisfactory

33. Wash Time minutes

General Subjective Comments

34. Splashing

35. Soiling

36. Comfort (seat, pressure points, positional variance, seal effectiveness, etc.)

37. Other

C) Locating/Centering Jet

38. Gas Pressure ; satisfactory, unsatisfactory
39. Gas Temperature °F(C); satisfactory, unsatisfactory
40. Positioning Effectiveness

Hamilton
Standard

U
DIVISION OF UNITED AIRCRAFT CORPORATION
A®

SVHSER 6182

APPENDIX C

FAILURE MODE AND EFFECTS ANALYSIS

C-i/C-ii

Page 1 of 10

Revision _____ Date _____

By _____

Dwg. _____

FAILURE MODE AND EFFECTS ANALYSIS
WASTE COLLECTION SUBSYSTEM

Systems: _____
Subsystems: _____
Equipment: _____
Mission Phase: _____

Ident. No.	Name	Reliab. Logic No.	Function	Failure Mode and Cause	Failure Effect on Component/Functional Assy.	Failure Effect on System	Criticality	Failure Detection Method	Crew Action Req.	Time Req./Avail
	Cycle Control		Turn on System Start Switch, which a. Turns off vacuum pump. b. Closes vacuum valve. c. Opens equalization valve. Pressure switch turns off red light. d. Starts 20 second timer, which 1. Closes equalization valve 2. Starts urinal fan 3. Starts commode fan 4. Starts urine separator 5. Starts slinger 6. Opens valve to commode fan	Fails to turn off Fails to close Fails to open Fails to turn off Fails to start Fails to close Fails to start Fails to start Fails to start Fails to start Fails to start Fails to open		Possible damage to vacuum pump. No effect unless vacuum pump doesn't turn off. (See vacuum valve failure modes.) Commode fan valve allows safe use of system for limited time. Trouble shooting would be required. Cannot open collector valve, and no entrainment flow would be started. Cannot dry the feces. Odor and bacteria growth would occur. Urine would not be cleared from the collector and urinal could not be used. The bolus might not disengage into the commode, thus greatly degrading the function of the commode. Commode cannot be used. Urine would not be cleared from the collector. Urinal could not be used. Surface area for drying would be inadequate. Feces would clog the entrainment gas outlets. Commode would be nearly useless. Same as (3) above.			If any functions controlled by cycle control do not operate, do not use commode system; checkout is required.	

Page 2 of 10
 Revision _____ Date _____
 By _____
 Dwg. _____

FAILURE MODE AND EFFECTS ANALYSIS

Systems: _____
 Subsystems: _____
 Equipments: _____
 Mission Phase: _____

Ident. No.	Name	Reliab. Logic No.	Function	Failure Mode and Cause	Failure Effect on Component/Functional Assy.	Failure Effect on System	Criticality	Failure Detection Method	Crew Action Req.	Time Req. Avail.
	Cycle Control (Continued)		7. Turns on green light	Green light doesn't come on		Trouble shooting would be required.				
			8. Unlocks collector valve.	Fails to unlock		Unable to use the commode.				
			Switch "on" Jet Control.	Fails to establish flow		Centering would be difficult.				
			Switch "off" Jet Control.	Fails to shut off		May result in splashing of fecal matter.				
			Open Collector (Gate) Valve, which locks out the turn-off switch.	Fails to open		Commode cannot be used.				
			Use the system.	Fails to lock-out turn-off switch		Inadvertent actuation of turn-off switch would cause premature turn off, but free passages into commode would prevent personal damage from vacuum.				
			Close Collector Valve, which rearms turn-off switch.	Fails to close.		Unable to dry feces. Bacteria would grow and odors would be produced.				
			Turn-off System, which starts timer, which	Fails to rearm turn-off switch		Unable to dry feces. Slinger, pumps, fans, and separator would run continuously.				
			a. Turns on yellow light	Fails to turn-on		Trouble shooting would be required.				
			b. Opens flush valve	Fails to open		The urine would have to be manually flushed.				
			c. Starts flush pump	Fails to start		Same as above.				
			d. Stop flush pump	Fails to stop		Flush pump would wear itself out, working against dead-headed volume.				
			e. Close flush valve	Fails to close		Flush water would leak into urinal and could flood the fan and urine separator.				

Page 3 of 10
 Revision _____ Date _____
 By _____
 Dwg. _____

FAILURE MODE AND EFFECTS ANALYSIS

Systems _____
 Subsystems _____
 Equipment: _____
 Mission Phases: _____

Ident. No.	Name	Reliab. Logic No.	Function	Failure Mode and Cause	Failure Effect on Component/Functional Assy.	Failure Effect on System	Criticality	Failure Detection Method	Crew Action Req.	Tim Req. Ava	
	Cycle Control (Continued)		f. Stop urinal fan g. Stop commode fan h. Stop urine separator i. Stop slinger j. Close valve to commode fan k. Turn-off yellow light l. Open vacuum valve m. Start vacuum pump n. Lock collector valve Pressure switch turns on red light. Exposes commode to vacuum or isolates commode from vacuum.	Fails to turn-off Fails to turn-off Fails to turn-off Fails to turn-off Fails to close Fails to turn-off Fails to open Fails to turn-on Fails to lock Fails to turn on Fail open or leak internally Fail closed	Failure Effect on Component/Functional Assy.	Premature wearout of the fan. Premature wearout of the fan. Premature wearout of the separator. Premature wearout of motor and possible damage to seals. A vacuum could not be established in the commode and feces would not be dried. Bacteria would grow and odors would be produced. Trouble shooting would be required. A vacuum could not be established in the commode and feces would not be dried. Bacteria would grow and odors would be produced. Same as above. The valve could be opened out of sequence with a loss in cabin gas during flight. Trouble shooting would be required. No effect for ground use, since vacuum can be controlled by the vacuum pump. For flight use the effect depends on the method of handling a "no-dump" requirement. A vacuum could not be established in the commode and feces would not be dried. Bacteria would grow and odors would be produced.					Do not use system. Turn system back on.

Page 4 of 10
 Revision _____ Date _____
 By _____
 Dwg. _____

FALLURE MODE AND EFFECTS ANALYSIS

Systems _____
 Subsystems _____
 Equipment _____
 Mission Phase _____

Ident. No.	Name	Reliab. Logic No.	Function	Failure Mode and Cause	Failure Effect on Component/Functional Assy.	Failure Effect on System	Criticality	Failure Detection Method	Crew Action Req.	Time Req./ Avail.
	Vacuum Valve (Continued)			Leak External,	This could prevent establishment of full vacuum in the commode and cause degradation of drying of feces.	The commode fan valve will allow use of system for a limited time. Vacuum would be compromised and drying would be impaired. There could be additional effects, depending on the method of handling the no-vent requirement. Possible degradation of rate of air flow through the commode during use.			System may be used, but requires checkout.	
	Equalization Valve		Fail closed.							
			External leak and internal leak.							
	Urinal Fan		To entrain the urine stream and carry it to the separator.	Fail open.		A vacuum could not be established in the commode and feces would not be dried. Bacteria would grow and odors would be produced. During use, the rate of air flow through the commode would be severely degraded Urine would not be cleared from the collector. Urinal could not be used. The fan design includes blade containment in the very unlikely event of loss of blades.		May be used for collection but must be repaired prior to any attempt to dry feces. Do not use system.		

Page 5 of 10

Revision _____ Date _____

By _____

Dwg. _____

FAILURE MODE AND EFFECTS ANALYSIS

System: _____

Subsystems: _____

Equipment: _____

Mission Phases: _____

Ident. No.	Name	Failsh. Logic No.	Function	Failure Mode and Cause	Failure Effect on Component/Functional Assy.	Failure Effect on System	Criti- cality	Failure Detection Method	Crew Action Req.	Time Req./ Avail.
	Commode Fan		To move feces to the slinger and to keep odors from getting into the cabin.	Failure to turn, or fan blade failure.		The bolts might not dis- engage into the commode, thus greatly degrading the function of the commode. The commode could not be used. The fan design includes blade containment in the very unlikely event of loss of blades.			Do not use system.	
	Urine Separator		To separate the urine from the entrainment air stream and deliver it to the urine tank.	Failure to accept mix or deliver gas flow. Liquid carryover in gas outflow. Failure to deliver urine. External leak.		Urine would not be cleared from the collector. Urinal could not be used. Discharge liquid urine droplets to the cabin. Urinal could not be used. Urine would back up in the system and would not clear from the collector. Urine droplets or odors discharged into the cabin.			Do not use urinal.	

Page 6 of 10
 Revision _____ Date _____
 By _____
 Dwg. _____

FAILURE MODE AND EFFECTS ANALYSIS

System: _____
 Subsystem: _____
 Equipment: _____
 Mission Phase: _____

Ident. No.	Name	Reliab. Logic No.	Function	Failure Mode and Cause	Failure Effect on Component/Functional Assy.	Failure Effect on System	Criticality	Failure Detection Method	Crew Action Req.	Time Req./ Avail.
	Valve to Commode Fan		To seal the commode system in order that a vacuum can be drawn.	Structural Falls closed External leak		Urine would move with air to the fan and be ejected into the cabin. Urinal could not be used. Same as fan failure. Vacuum would be compromised and drying would be impaired. There could be additional effects, depending on the method of handling the no-vent requirement. Possible degradation of rate of air flow through commode. Loss of cabin air and inability to maintain full vacuum for drying feces. A vacuum could not be established in the commode and feces would not be dried. Bacteria would grow and odors would be produced.			Do not use commode.	
	Jet Control		To enable the user to center his body over the commode.	Falls open		Centering would be made difficult. Excess use of N ₂ .			Turn system on.	
	Flush Water Valve		To prevent flush water from flowing from flush water tank when not needed.	Falls closed External leak Internal leak		The urinal would have to be manually flushed. Flush water would leak to cabin atmosphere. Flush water would leak into urinal.			User would have to position carefully but system may be used. Turn off source. Manually flush urinal.	

Page 7 of 10
Revision _____ Date _____
By _____
Dwg. _____

FAILURE MODE AND EFFECTS ANALYSIS

Systems: _____
Subsystems: _____
Equipment: _____
Mission Phases: _____

Ident. No.	Name	Reliab. Logic No.	Function	Failure Mode and Cause	Failure Effect on Component/Functional Assy.	Failure Effect on System	Criticality	Failure Detection Method	Crew Action Req.	Time Req./Avail.
	Flush Water Valve (Continued)			Falls open		Same as above. Eventually flush water would be discharged into cabin atmosphere.			Turn off source.	
	Flush Water Pump		To provide flush water flow for flushing urinal.	Falls to turn Clogged External leak		The urinal would have to be manually flushed. Same as above. Flush water would leak to cabin atmosphere.			Manually flush urinal.	
	Commode Seat Cover		For appearance.	Jam in closed position		Negligible probability.			Do not use system.	
	Collector (Gate) Valve		To open a passage for feces into the commode and to seal the passage for the drying cycle.	Jam in open position or intermediate position Jam in closed position Leak		Unable to dry the feces. Bacteria would grow and odors would be produced. Unable to use the commode. A vacuum could not be established in the commode and feces would not dry properly. Bacteria would grow and odors would be produced.			Do not shut system down. Do not use system.	
	Collector Vessel		To provide a container for the feces and a vacuum chamber for drying feces.	Leak Collapse		Same as above. Negligible probability.			Do not use system.	

Page 8 of 10
 Revision _____ Date _____
 By _____
 Dwg. _____

FAILURE MODE AND EFFECTS ANALYSIS

Systems _____
 Subsystems _____
 Equipment _____
 Mission Phase _____

Ident. No.	Name	Reliab. Logic No.	Function	Failure Mode and Cause	Failure Effect on Component/Functional Assy.	Failure Effect on System	Criticality	Failure Detection Method	Crew Action Req.	Time Req./Avail.
	Slinger		To locate the feces uniformly about the circumference of the collector and to facilitate drying.	Fails to turn Looses blades		Surface area for drying would be inadequate. Feces would clog the outlets for entrainment air. Commode would become severely degraded and nearly useless. The slinger and structure can withstand the loss of blades. The blades cannot bounce to strike the user. If all blades are lost the slinger function will be degraded. Function would be degraded but torque is sufficient to prevent stopping of rotation.			Do not use fecal collection system. Do not use fecal collection system.	
CS	Urinal		To form air entrainment passages and direct and collect urine stream.	Clogs with feces and paper Structural or leak		Possible introduction of urine or flush water to cabin environment.			Do not use urinal.	
	Flush Water Tank		To store treated water for flushing the urinal.	Bladder leak Tank leak Explosion		At zero-g this could cause loss of availability of the flush water. At one-g there would be no effect. Loss of pressurant. At zero-g, this could cause failure to pump flush water, and thus complete loss of flushing function. Either the tank or the pressurant supply will be protected by relief valving. Thus failure probability is negligible.			No effect on system. Manually flush system.	

Page 9 of 10
 Revision _____ Date _____
 By _____
 Dwg. _____

FAILURE MODE AND EFFECTS ANALYSIS

Systems _____
 Subsystems _____
 Equipment _____
 Mission Phases _____

Ident. No.	Name	Reliab. Logic No.	Function	Failure Mode and Cause	Failure Effect on Component/Functional Assy.	Failure Effect on System	Criticality	Failure Detection Method	Crew Action Req.	Time Req./Avail
	Flush Water Tank (Continued)			Mountings fail		This could lead to a leak and its effect as shown above.			Dump tank to outside do not use system.	
	Urine Tank		To store urine during the mission.	Tank leak Relief valve fails open or leaks Relief valve fails closed		Introduction of urine to the cabin atmosphere. At zero-g excessive urine may flow back to the separator inlet and overload it. Tank will withstand full separator head, so that rupture will not occur. However, urine would back-up in the system and not clear from the collector. This could lead to broken connections, resulting in leakage from the system. Function would be ineffective.			Do not use system.	
	Bacteria Filter		Prevent expulsion of bacteria laden gas to cabin.	Mountings fail Fail to collect bacteria Clogging		Both the commode and urinal flow would be affected. Urine would not be cleared from the collector. Urinal could not be used. The bolus might not disengage into the commode, thus greatly degrading the function of the commode. Odors would escape into the cabin. Bacteria laden gas could escape to the cabin environment.			Do not use system. Change filter. Change filter.	
				External leak					Change filter.	

Page 10 of 10
 Revision _____ Date _____
 By _____
 Dwg. _____

FAILURE MODE AND EFFECTS ANALYSIS

System: _____
 Subsystem: _____
 Equipment: _____
 Mission Phase: _____

Ident. No.	Name	Fallab. Logic No.	Function	Failure Mode and Cause	Failure Effect on Component/Functional Assy.	Failure Effect on System	Criticality	Failure Detection Method	Crew Action Req.	Time Req./ Avail.
	Odor Removal Filter		To prevent odors from being discharged into the cabin.	Failure to absorb odor Clog		Introduction of noxious odors into the cabin. Same as for clogging of bacteria filter.			Change filter. Change filter.	
	Urine Check Valve		To prevent back-flow of urine from the tank.	Fails open or leaks Fails closed		Depending on detail design of pump; could allow some leakage back thru system. Insignificant probability.			Do not use system.	