

(CLASSIFIED BY 11) (POLYGRAPHED BY 11)

(CLASSIFIED BY 11) (POLYGRAPHED BY 11)

(CLASSIFIED BY 11) (POLYGRAPHED BY 11)

(CLASSIFIED BY 11) (POLYGRAPHED BY 11)

(CLASSIFIED BY 11) (POLYGRAPHED BY 11)

175-11-1

175-11-1

175-11-1

175-11-1

APOLLO-SOYUZ TEST PROJECT

OPERATIONS HANDBOOK COMMAND/SERVICE/DOCKING MODULES

CSM 119/DM 1

OPERATIONAL PROCEDURES REFERENCE ISSUE

PREPARED BY
ROCKWELL INTERNATIONAL
UNDER DIRECTION
OF
CREW TRAINING AND PROCEDURES DIVISION

CONTRACT NAS9-13100
SD 72-CS-0040
DRL LINE ITEM NO. 9



National Aeronautics and Space Administration
LYNDON B. JOHNSON SPACE CENTER
Houston, Texas

SD 74-CS-0026

15 JULY 1974



NATIONAL AERONAUTICS AND SPACE ADMINISTRATION
LYNDON B. JOHNSON SPACE CENTER
HOUSTON, TEXAS 77058

REPLY TO: CG5-704-175
ATTN OF:

August 26, 1974

MEMORANDUM

TO: JM/Chief, Printing Management Office

FROM: CG5/Chief, Flight Planning Branch

SUBJECT: ASTP Operations Handbook, Command/Service Module, CSM 119,
Volume II, JSC 09092

Subject handbook is currently in printshop for reproduction. The number of printed copies versus distribution requirements (250 versus 228) leaves 22 copies to be delivered to this office. The attachment defines the required distribution and should be inserted behind the cover sheet.

It is requested that the negatives be returned to Rockwell International at the following address:

Rockwell International Corporation
Space Division
12214 Lakeview Boulevard
Downey, California 90241
Attn: Data Management
D/095 - Bldg. 1
S100 - E37

Tony W. Holloway

Enclosure

CG5/RAMccs:jt:8/26/74:250

JSC-09092

APOLLO-SOYUZ TEST PROJECT
OPERATION HANDBOOK

COMMAND/SERVICE/DOCKING MODULES
SYSTEMS OPERATING PROCEDURES
CSM 119/DM 1

APPROVED



C.W. Helms, Chief Program Engineer
CSM Programs, Space Division
Rockwell International Corporation

Contract NAS9-13100

Prepared under direction
of

NATIONAL AERONAUTICS AND SPACE ADMINISTRATION
LYNDON B. JOHNSON SPACE CENTER
CREW TRAINING & PROCEDURES DIVISION

APPROVED

T.W. Holloway, Acting Chief
Data Management Office

15 July 1974
Document Issue Date

APOLLO-SOYUZ TEST PROJECT (ASTP)
OPERATIONS HANDBOOK

HANDBOOK CHANGE CONTROL

The June 1974 publication of this handbook shall be a complete handbook reissue, identified on the cover as a REFERENCE publication. Continuity from this reference issue to final publication dated October 1, 1974, shall be documented by applicable "Crew Procedures Change Request" - MSC Form 482B. Systems operating procedures which cannot be adequately defined because of lack of hardware definition will be identified as TBD. No procedural "TBD" will appear in the final publication providing the hardware configuration is adequate to define operating procedures. All NASA-approved change proposals shall be included in the final published handbook, allowing two weeks cutoff prior to publication date for copy and edit functions. There are two types of changes: RECORD CHANGE and CONTROL CHANGE.

RECORD CHANGE: A record change may be incorporated by the contractor without formal coordination and approval by NASA. Such changes shall consist of non-procedural changes to the format or Remarks column, corrections of an editorial nature, and implementation of specific changes directed by CCP actions where interpretation of procedural intent is clear. Supporting information as appropriate shall be included on Form 482B in the space marked "Reason for Change." Informational copies of all record changes will be directed to JSC Crew Training and Procedures Division (CT&PD), Data Management Office (DMO), Mail Code CG121, on MSC Form 482B.

CONTROL CHANGE: A control change originates on MSC Form 482B as a handbook change proposal, and includes the technical rationale in support of the proposed change, applicable references, etc. The scope of a change proposal shall be of a small enough magnitude to properly lend itself to the intent of change control. Each change submittal shall clearly indicate CSM-111 or CSM-110 effectivity. The initiator shall direct the original copy of Form 482B to CT&PD (DMO), where a control number and suspense date will be assigned (approximately two weeks); the change proposal will be reproduced and distributed to affected organizations for technical review and response within five working days of receipt of the proposed change. A "no response" philosophy is adopted for individual JSC organizations. No reply to CT&PD (DMO) prior to change suspense date indicates change concurrence by the reviewing organization; however Rockwell International shall give positive concurrence or nonconcurrence to CT&PD (DMO) for each change prior to expiration of change suspense date. All change proposals originating within MSFC or contractor organizations must be approved by that originating organization prior to submittal to CT&PD (DMO). During the review cycle (prior to expiration of suspense date), CT&PD (DMO) may modify the change proposal by an "A" revision (new data, change error, effectivity change, etc.), assign a new suspense date and recycle review copies of the modified change. At the expiration of the suspense date, CT&PD ASTP Flight Data Manager (FDM) shall approve or disapprove each change proposal, contingent upon review results. Change approval by NASA is direction to the contractor to incorporate those FDM-approved changes into the final published handbook update -- allowing two weeks cutoff prior to publication date for copy and edit functions.

...cont

Basic Date 15 July 1974 Change Date _____ Page _____

APOLLO-SOYUZ TEST PROJECT (ASTP)
OPERATIONS HANDBOOK

Every disapproval by CT&FD will be supported by the technical rationale for disapproval, and such rationale will be directed back to the change initiator. If the disapproval is not applicable to the entire change proposal, the change initiator must resubmit the valid portions (if any) of the disapproved change as a new change proposal. If the disapproval by CT&FD (FDF) appears erroneous or unjustified by the change initiator, he may petition the CPCB for disposition reversal. NASA approval and release of guidance system program changes for specific vehicle effectivities shall constitute adequate contractor authorization to revise applicable operating procedures accordingly, without additional change control review and approval.

All procedures emphasis and change control subsequent to the October 1, 1974 final Operations Handbook issue shall shift to the ASTP Flight Data File (FDF) and each procedures change (482B) shall be addressed to appropriate FDF article(s). Refer to the Crew Procedures Management Plan (JSC 08466) for change control and FDF development (Crew Procedures Control Board) commencing at launch minus 9 months.

The final published handbook, dated October 1, 1974, shall identify all changes incorporated by control and record change numbers and shall provide change bar identifiers for the technical changes in the text margin. A MSC Form 482B "CREW PROCEDURES CHANGE REQUEST" is included within this handbook for user convenience -- and may be reproduced for multiple change submittals.

CREW PROCEDURES CHANGE REQUEST

SECTION	ORGANIZATION / PRIMARY P	INITIATOR'S CPDB MEMBER SIGNATURE	DATE SUBMITTED
DOCUMENT AFFECTED			
TITLE	BASIC CHR. DATE	PAGE NUMBER	MISSION
CONTROL NUMBER			

DETAIL CHANGE IN EXACT WORDING:

TECHNICAL RATIONALE:

OTHER DATA AFFECTED:

CPD DISPOSITION

CHANGE CLASSIFICATION	BOOK MANAGER APPROVAL	BRANCH CHIEF APPROVAL	FLIGHT DATA MANAGER APPROVAL	ACTIVITY ELEMENT
FORMAT <input type="checkbox"/>	SIGNATURE/DATE _____	SIGNATURE/DATE _____	SIGNATURE/DATE _____	COMPLEX ACTIVITY
TECHNICAL RECORD <input type="checkbox"/>	DISAPPROVED <input type="checkbox"/>	DISAPPROVED <input type="checkbox"/>	DISAPPROVED <input type="checkbox"/>	DATE: NOT EARLIER THAN _____ NO LATER THAN _____
TECHNICAL INTERIM <input type="checkbox"/>	IMPLEMENTATION: TRAINING SUPPORT <input type="checkbox"/> ROUTINE <input type="checkbox"/>			
TECHNICAL HOLD <input type="checkbox"/>	MOPS <input type="checkbox"/> CPDS <input type="checkbox"/> FDF <input type="checkbox"/> OH <input type="checkbox"/> OTHER _____			

CPCB DISPOSITION

CPCB SCHEDULE DATE	FCOD APPROVAL SIGNATURE _____	DISAPPROVED <input type="checkbox"/>	DATE
--------------------	----------------------------------	--------------------------------------	------

CHANGE REQUEST INSTRUCTIONS

GENERAL - To effect complete coordination and evaluation, it is necessary to reproduce and distribute copies of each change request. In order to assure all recipients receive legible copies, please print all entries and prepare mark-ups using black ink.

INITIATOR NAME/ADDRESS/PHONE - Use address and phone number where requestor can be reached if different from official address.

INITIATORS CPCB MEMBER SIGNATURE - Must be signed off by the CPCB member of the initiators organization before the change request will be processed by the Flight Data Manager.

DATE - Indicate the date (month, day, year) the change request is submitted.

TITLE - Use only the official title as shown on the cover of the FDF article.

BASIC/CHG DATE - Indicate the latest date of publication or change to the affected article.

PAGE NUMBER - List all pages affected by the change.

MISSION - Denote mission applicability; if valid for all missions - "All."

CONTROL NUMBER - Leave blank. This number will be assigned by the Data Management Control Office.

DETAIL CHANGE IN EXACT WORDING - Self-explanatory.

TECHNICAL RATIONALE - Self-explanatory.

OTHER DATA AFFECTED - Indicate any other data articles, documents or data elements affected by the change.

The remainder of the form will be completed by the Book Manager and/or Flight Data Manager and the Data Management Control Office.

APOLLO-SOYUZ TEST PROJECT (ASTP)
OPERATIONS HANDBOOK

TABLE OF CONTENTS

Section	Title	Page
1.0	BACKUP CREW PRELAUNCH CHECKS	1-1
1.1	C&WS Status Check	1-1
1.2	EMS Prelaunch Tests	1-2
1.3	Glycol Loop Checks	1-6
1.4	Standby Inverter (No. 3) Check	1-7
1.5	Float ^{Pa} g Check	1-8
1.6	LHEB ECS Valve Status	1-9
1.7	LEB and Timer Panel 306	1-10
1.8	RHEB and Panel 601	1-13
1.9	ORDEAL Switch Position Check	1-13
1.10	LH Couch Checks	1-14
1.11	RH Couch Checks	1-22
1.12	Communications Check	1-30
1.13	Verify Couch Configuration	1-32
1.14	Prime Crew Pre-Ingress Procedure	1-32
2.0	PRIME CREW PRELAUNCH CHECKS	2-1
2.1	Ingress and Status Checks	2-1
2.1.1	AC Ingress to LH Couch	2-1
2.1.2	DP Ingress to RH Couch	2-2
2.1.3	CP Ingress to Center Couch	2-3
2.1.4	EDS Checkout and Countdown Test	2-4
2.1.5	TV Camr Checkout (TBD)	2-5
2.1.6	Cabin Closeout	2-5
2.1.7	Change Launch Azimuth (if necessary)	2-7
2.1.8	EDS Test Complete	2-7
2.2	Final Verification and Systems Checks	2-8
2.2.1	G&C Verification	2-8
2.2.2	Gimbal Drive and Trim Check	2-10
2.2.3	FDAI Verification	2-13
2.2.4	RSI Test & Setup	2-13
2.2.5	EMS Preparation	2-14
2.2.6	Pad Abort Enable	2-14
2.2.7	SM RCS Activation	2-15
2.2.8	SM RCS Status Check	2-16
2.3	Launch Preparation	2-17
3.0	BOOST AND INSERTION	3-1
3.1	Boost	3-1
3.2	Postorbital Insertion Check	3-10
3.2.1	Status Checklist	3-11
3.2.2	SCS Attitude Reference Comparison Check	3-13
3.2.3	SCT/SXT Dust Cover Jett Procedure	3-13
3.2.4	ECS Postinsertion Configuration	3-14
3.2.5	Systems Verification and Monitoring	3-16
3.2.6	Cabin Atmosphere Verification	3-17

APOLLO-SOYUZ TEST PROJECT (ASTP)
OPERATIONS HANDBOOK

Section	Title	Page
4.0	DM INTERFACE	4-1
4.1	CSM/SLA Separation, Transposition and Docking	4-1
4.2	Preparation for DM Ejection	4-11
4.3	DM Ejection From SLA	4-14
4.4	DM Jettison and Separation	4-23
4.5	Pre-docking DM Checkout	4-25
4.6	CSM Undocking From DM	4-27
5.0	SYSTEMS MANAGEMENT	5-1
5.1	General Data	5-1
	5.1.1 Systems Test Indicator Readouts	5-1
	5.1.2 Limited Use Circuit Breakers	5-6
5.2	Propulsion Systems	5-10
	5.2.1 SPS Monitoring Check	5-10
	5.2.2 SM RCS Monitoring Check	5-11
	5.2.3 CM RCS Monitoring Check	5-13
5.3	Electrical Power System	5-15
	5.3.1 Cryogenic Pressure-Quantity Check	5-17
	5.3.2 FC Power Plant Check	5-23
	5.3.3 D-C Voltage-Amperage Check	5-18
	5.3.4 A-C Voltage Check	5-18
	5.3.5 Battery A (B,C) Charging	5-19
	5.3.6 FC Power Plant Purging	5-20
	5.3.7 Fuel Cell Load Disconnect	5-21
	5.3.8 Inverter Changeover	5-23
	5.3.9 H2 Manual Fan Operation	5-26
5.4	Environmental Control System	5-27
	5.4.1 ECS Monitoring Check	5-28
	5.4.2 ECS Redundant Component Check	5-30
	5.4.3 CO2 Absorber Filter Replacement	5-33
	5.4.4 Debris Screen Check	5-34
	5.4.5 Potable Water Chlorination	5-35
	5.4.6 PGA Mode Changes	5-37
	5.4.7 Waste Management Procedures	5-41
	5.4.8 CM Repressurization	5-49
	5.4.9 Pressure Suit Circuit & PGA Check at 5.0 Psia	5-51
	5.4.10 CM O2 Supply Refill	5-55
	5.4.11 CM Pressure Dump	5-55
	5.4.12 Suit Circuit Purge of H2	5-57
	5.4.13 Cabin Cold-Soak Operation	5-57
	5.4.14 Operation of Emergency O2 Masks	5-59
	5.4.15 Waste Water Tank Drain	5-59
	5.4.16 Gas Separator Cartridge Servicing	5-60
	5.4.17 Primary Glycol Evaporator Operation	5-61
	5.4.18 Cabin Leak Check	5-61
	5.4.19 VTR Suit Hose Utilization	5-62

APOLLO-SOYUZ TEST PROJECT (ASTP)
OPERATIONS HANDBOOK

Section	Title	Page
5.5	Caution and Warning System	5-63
5.5.1	C&W Operational Check	5-64
5.5.2	Dark Adaptation Adjustment	5-65
5.5.3	Acknowledge/Reset Master Alarm Indication	5-65
5.5.4	Master Alarm Tone Headset Control	5-66
5.5.5	C/W Memory Operation	5-67
5.5.6	C/W Lights/Inhibit Memory Switch Matrix	5-68
5.5.7	Normal Operation C/W Master Alarms	5-73
5.6	Telecommunications	5-74
5.6.1	Basic Switch Configuration	5-74
5.6.2	VHF/AM Modes	5-78
5.6.3	VHF/FM Modes	5-79
5.6.4	VHF/AM Ranging Mode	5-79
5.6.5	Pad Communications	5-80
5.6.6	S-Band Xponder Modes	5-81
5.6.7	FM Xmtr Mode	5-81
5.6.8	DSE Record Modes	5-82
5.6.9	Relay Mode (VHF FM to MCC-E via SBD)	5-82
5.6.10	Sleep Configuration	5-82
5.6.11	Backup Modes	5-83
5.6.12	TV Oper (TBD)	5-84
5.6.13	TV Modes (TBD)	5-84
5.7	Mechanical Systems	5-85
5.7.1	Forward Hatch Removal	5-85
5.7.2	Forward Hatch Installation	5-85
5.7.3	Forward Hatch Seal Integrity Check	5-86
5.7.4	Docking Probe Removal	5-88
5.7.5	Docking Probe Installation	5-92
5.7.6	Docking System Probe Extension and Status Check	5-95
5.7.7	Docking Drogue Removal	5-96
5.7.8	Docking Drogue Installation	5-96
5.7.9	Probe Preload Operation	5-97
5.7.10	Tunnel Latch Operations	5-98
5.8	Floodlight Operating Modes	5-101
5.8.1	Prim Floodlight Mode	5-101
5.8.2	Sec Floodlight Mode	5-101
6.0	G&C REFERENCE DATA	6-1
6.1	G&C Operating Notes	6-1
6.1.1	G&C Operations	6-17
6.1.2	SCS Operations	6-24
6.1.3	G&N Operations	6-31
6.2	Verb List	6-35
6.3	Noun List	6-45
6.4	Star List	6-47
6.5	Checklist Reference Codes (V50 N25)	6-48
6.6	Option Codes (V04 N06 or V04 N12)	6-50
6.7	Alarm Codes (V05 N09)	6-50

APOLLO-SOYUZ TEST PROJECT (ASTP)
OPERATIONS HANDBOOK

Section	Title	Page
6.8	CMC Program - Routine Index	6-58
	6.8.1 Programs	6-58
	6.8.2 Routines	6-61
6.9	CMC Program - Flag Listing	6-63
7.0	G&N REFERENCE MODES	7-1
7.1	Attitude Control	7-1
	7.1.1 SCS Channel Selection	7-1
	7.1.2 SCS Minimum Impulse	7-3
	7.1.3 SCS Acceleration Command	7-3
	7.1.4 SCS Attitude Hold/Rate Command	7-4
	7.1.5 CMC Minimum Impulse	7-5
	7.1.6 CMC Attitude Control - Auto/Hold	7-6
	7.1.7 SIVB Attitude Control	7-7
	7.1.8 Direct RCS	7-8
7.2	Dynamic Display Monitor	7-9
	7.2.1 Rate Display	7-9
	7.2.2 Attitude Error Display - EMAG Source	7-10
	7.2.3 Attitude Error Display - CMC Source	7-11
	7.2.4 Attitude Error Display - Attitude Set Source	7-12
	7.2.5 Total Attitude	7-13
	7.2.6 ORDEAL - Local Horizontal Attitude	7-15
7.3	GDC Align	7-16
7.4	SPS Thrusting Control	7-17
	7.4.1 TVC Initialization	7-17
	7.4.2 SPS Gimbal Control	7-17
	7.4.3 Thrust On-Off Control	7-21
7.5	Optics Control	7-23
	7.5.1 Auto Optics Positioning	7-23
	7.5.2 Manual Optics Control	7-23
	7.5.3 Manual Optics Drive	7-24
7.6	Entry Monitor System (EMS)	7-25
	7.6.1 ΔV Test and Null Bias Check	7-25
	7.6.2 ΔV Setup	7-27
8.0	G&C GENERAL PROCEDURES	8-1
8.1	G&N General	8-2
	8.1.1 (P00) CMC Idling Program	8-2
	8.1.2 CMC/IMU Power Down	8-2
	8.1.3 Startup	8-3
	8.1.4 Optics Power Control	8-4
	8.1.5 (P27) CSM - CMC Update	8-5
	8.1.6 (P47) G&N Thrusting Monitor Program	8-9
	8.1.7 (P48) Rendezvous Thrust Monitor	8-10
	8.1.8 CMC Self-Check Procedure	8-13
	8.1.9 Measurement and Loading of PIPA Bias	8-13
	8.1.10 ΔR and ΔV Threshold Change Procedure	8-15
	8.1.11 Flagword Monitor and Change Procedure	8-16
	8.1.12 Chan 31/33 Control Mode Override (C31FLWRD)	8-17

APOLLO-SOYUZ TEST PROJECT (ASTP)
OPERATIONS HANDBOOK

Section	Title	Page
	8.1.13 G&H Passive Thermal Control Procedure	8-18
	8.1.14 Saturn Rate Change	8-20
	8.1.15 (R02) IMU Status Check	8-21
	8.1.16 DSKY 8's Clear Procedure	8-22
	8.1.17 Backup CMC Clock Initialization - <u>TBD</u>	8-22
8.2	Digital Autopilot (DAP)	8-23
	8.2.1 (V48) Undocked DAP Data Load (R03)	8-23
	8.2.2 (V44) Docked DAP Data Load (R04)	8-24
	8.2.3 RCS DAP Attitude Deadband Change Procedure	8-26
	8.2.4 RCS DAP Orbital Rate Procedure	8-27
	8.2.5 PTC (P20 Option 2)	8-33
	8.2.6 Orb Rate (P20 Option 2)	8-35
8.3	Extended Verbs	8-37
	8.3.1 (V35) DSKY Condition Light Test	8-37
	8.3.2 (V42) Torque Gyros	8-38
	8.3.3 (V43) Load FDAI Error Needles	8-39
	8.3.4 (V49) CSA Crew Defined Maneuver (R62)	8-40
	8.3.5 (V57) Full Track Flag Specification	8-41
	8.3.6 (V64) Optics Angle Transform (R64)	8-42
	8.3.7 (V67) Start W-Matrix RSS Error Display	8-43
	8.3.8 (V74) Initialize Erasable Dump Via Downlink	8-45
	8.3.9 (V91) Display Banksum	8-45
8.4	SCS General	8-46
	8.4.1 SCS Power Down	8-46
	8.4.2 SCS Power Up	8-47
	8.4.3 Drift Rate Adjust	8-48
	8.4.4 Minimum Power SCS Attitude Hold (Three or Two Axes)	8-50
	8.4.5 SCS Attitude Maneuver	8-51
	8.4.6 GDC Alignment to IMU Gimbal Angles	8-52
	8.4.7 Attitude Reference System Comparison	8-53
	8.4.8 ORDEAL Initialization	8-55
	8.4.9 SCS Passive Thermal Control Using Wobble Mode	8-57
	8.4.10 SCS Passive Thermal Control Using BAR-B-Q Minimum Power Mode	8-58
9.0	RENDEZVOUS	9-1
	9.1 Manual Rendezvous Sequence	9-1
	9.2 MINKEY Rendezvous Sequence	9-2
	9.2.1 MINKEY Operating Notes	9-2
	9.2.2 MINKEY Rendezvous Sequence (Flow)	9-4
10.0	NAVIGATION	10-1
	10.1 Orbital Navigation	10-1
	10.1.1 (P21) Ground Track Determination	10-1
	10.1.2 (P29) Time of Longitude	10-3
	10.1.3 (V82) Orbit Parameter Display (R30)	10-5

APOLLO-SOYUZ TEST PROJECT (ASTP)
OPERATIONS HANDBOOK

Section	Title	Page
10.2	Rendezvous Navigation	10-7
10.2.1	(P20) Universal Tracking and Rendezvous Navigation	10-7
10.2.2	(P25) Contingency VHF Range Rate	10-24
10.2.3	(V83) Rendezvous Parameter Display #1 (R31)	10-26
10.2.4	(V85) Rendezvous Parameter Display #2 (R34)	10-27
10.2.5	(V90) Rendezvous Out of Plane Display (R36)	10-28
10.2.6	(V89) Rendezvous Final Attitude (R63)	10-29
10.2.7	(P77) Target Delta V	10-31
11.0	PRETHRUSTING	11-1
11.1	Orbit Change Prethrusting	11-1
11.1.1	(P30) External Delta V Prethrusting	11-1
11.2	Rendezvous Prethrusting	11-4
11.2.1	(P31) Normal Corrective Maneuver #1 (NC1)	11-4
11.2.2	(P32) Normal Corrective Maneuver #2 (NC2)	11-11
11.2.3	(P33) Normal Corrective Combination Maneuver (NCC)	11-18
11.2.4	(P34) Normal Slow Rate Maneuver (NSR)	11-25
11.2.5	(P35) Transfer Phase Initiation (TPI)	11-32
11.2.6	(P36) Transfer Phase Midcourse (TPM)	11-40
11.2.7	(P37) Transfer Phase Final (TPF)	11-46
11.2.8	(P38) Plane Change Targeting (NPC)	11-50
12.0	THRUSTING	12-1
12.1	Vehicle Preparation	12-1
12.2	G&N Thrusting	12-3
12.2.1	(P40) G&N/SPS Thrusting	12-3
12.2.2	(P41) G&N/SM-RCS Thrusting	12-21
12.2.3	G&N/Hybrid Deorbit Thrusting	12-27
12.3	SCS Thrusting	12-34
12.3.1	SCS/SPS Thrusting	12-34
12.3.2	SCS/SM RCS Thrusting	12-47
12.3.3	SCS Hybrid Deorbit Thrusting	12-50
13.0	ALIGNMENTS	13-1
13.1	G&N Alignments	13-1
13.1.1	(P50) Soyuz Orientation Determination	13-1
13.1.2	(P51/P53) IMU Orientation Determination	13-5
13.1.3	(P52/P54) IMU Realign	13-11
13.1.4	(P55) ATM Star Tracker Gimbal Angle Program	13-23
13.1.5	(V40) Zero ICDU Extended Verb	13-28
13.1.6	(V41 N20) Coarse Align ICDU Extended Verb	13-29
13.1.7	(V41 N91) Coarse Align OCDU Extended Verb	13-30
13.1.8	Inflight COAS Calibration	13-31

APOLLO-SOYUZ TEST PROJECT (ASTP)
OPERATIONS HANDBOOK

Section	Title	Page
13.2	SCS Alignments	13-34
13.2.1	Alternate SC Inertial Attitude Determination and GDC Alignment	13-34
13.2.2	Inplane GDC Alignment	13-36
13.2.3	Backup GDC Alignment With COAS	13-38
13.3	G&C Alignments	13-40
13.3.1	Backup GDC and/or IMU Alignment	13-40
14.0	ENTRY	14-1
14.1	Deorbit and Entry Vehicle Preparation	14-1
14.1.1	General System Management	14-1
14.1.2	RSI Test and Alignment	14-3
14.1.3	FMS Deorbit and Entry Test	14-3
14.1.4	Systems Preparation	14-6
14.2	CM/SM Separation	14-9
14.3	G&N Entry	14-13
14.3.1	P61 Entry Preparation	14-13
14.3.2	P62, P63, P64, P67 Entry	14-16
14.4	SCS Entry	14-22
15.0	EARTH LANDING PHASE (50K')	15-1
16.0	POSTLANDING	16-1
16.1	Postlanding Stabilization	16-1
16.2	Post Stabilization and Ventilation	16-5
16.3	Postlanding Communications	16-8
16.3.1	Normal Postlanding Communications	16-8
16.3.2	Survival Transceiver Communications	16-8
16.3.3	Communications Low Power Procedures	16-9
16.3.4	S/C Power Down (Extended Comm Period)	16-10
16.4	Unaided Egress Procedures	16-11
16.4.1	Egress Preparation	16-11
16.4.2	Stable I Water Egress	16-12
16.4.3	Stable II Water Egress	16-13
16.4.4	Side Hatch Operations - Rough Sea	16-14
16.5	Nominal Egress Procedures	16-16
16.5.1	Nominal Egress Preparation	16-16
16.5.2	Nominal Egress & Power Down	16-16
17.0	CSM/DM EXPERIMENTS	17-1
17.1	Not Applicable	17-1
17.2	G&C Systems Preparation	17-1
17.3	Not Applicable	17-1
17.4	Not Applicable	17-1
17.5	Not Applicable	17-1

APOLLO-SOYUZ TEST PROJECT (ASTP)
OPERATIONS HANDBOOK

Section	Title	Page
17.6	Ultraviolet Absorption (UVA)	17-2
	17.6.1 Connect Drag Thru Cable	17-3
	17.6.2 UVA Cover Open (Close)	17-3
	17.6.3 UVA/COAS Alignment	17-3
	17.6.4 UVA Operation	17-5
	17.6.5 UVA Deactivation	17-6
	17.6.6 UVA Calibration	17-6
	17.6.7 Disconnect Drag Thru Cable	17-6
17.7	Not Applicable	17-7
17.8	Stratospheric Aerosol Measurement (SAM)	17-8
	17.8.1 SAM Installation	17-8
	17.8.2 SAM Operation/Data Collection	17-8
	17.8.3 SAM Removal	17-10
17.9	Multipurpose Electric Furnace System (MEFS)	17-11
	17.9.1 Furnace Evacuation	17-11
	17.9.2 Furnace He Injection	17-11
	17.9.3 Sample Cartridge Prep	17-12
	17.9.4 Sample Cartridge Initiate	17-12
	17.9.5 Sample Cartridge Termination	17-14
	17.9.6 Furnace Lamp Test	17-15
	17.9.7 Sample Cartridge Temp Verification	17-15
17.10	Electrophoresis Experiment (EPE)	17-16
	17.10.1 EPE Preparation	17-16
	17.10.2 EPE Initiate	17-17
	17.10.3 EPE Termination	17-18
	17.10.4 EPE Lamp Test	17-18
17.11	Electrophoresis Technology Experiment (ETE)	17-19
	17.11.1 ETE Preparation	17-19
	17.11.2 ETE Operation - Electrophoresis/ Isotachopheresis	17-20
	17.11.3 ETE Termination	17-22
17.12	Light Flash (LF)	17-23
	17.12.1 LF Preparation	17-23
	17.12.2 LF Operation (Manned)	17-24
	17.12.3 LF Operation (Unmanned)	17-25
	17.12.4 LF Disassembly	17-25
17.13	Crystal Growth Experiment (CGE)	17-26
	17.13.1 Crystal Growth Activation	17-26
	17.13.2 Photographic Observations	17-27
17.14	Not Applicable	17-27
17.15	Earth Observation	17-28
17.16	Solar Eclipse	17-29

APOLLO-SOYUZ TEST PROJECT (ASTP)
OPERATIONS HANDBOOK

Section	Title	Page
18.0	APOLLO-SOYUZ OPERATIONS	18-1
18.1	Docking Module/Soyuz Docking and Undocking - CM Active	18-1
18.1.1	Docking With Soyuz, CM Active	18-1
18.1.2	Undocking With Soyuz, CM Active	18-7
18.2	Docking Module/Soyuz Docking and Undocking - CM Passive	18-10
18.2.1	Docking With Soyuz, Apollo DM Passive	18-10
18.2.2	Undocking With Soyuz, Apollo DS Passive	18-13
18.3	Environmental Control/Life Support System Operations	18-177
18.3.1	Docking Module Pressure Integrity Check	18-17
18.3.2	DM Pressurization	18-18
18.3.3	DM Depressurization	18-21
18.3.4	Tunnel #2 Integrity Check	18-23
18.3.5	Tunnel #2 Pressurization	18-24
18.3.6	Tunnel #2 Depressurization and Hatch #3 Integrity Check	18-25
18.3.7	Face Mask Operation	18-26
18.3.8	High DM CO2 Partial Pressure (15 mm Hg)	18-26
18.4	Electrical Power System	18-27
18.4.1	DM Ingress Config	18-27
18.4.2	DM Occupied Config & C&WS Operational Check	18-27
18.4.3	DM Vacant Config	18-28
18.4.4	DM Jettison Config	18-28
18.4.5	Struct Latches Load Cell Test (CM Active)	18-28
18.4.6	Struct Latches Load Cell Test (CM Passive)	18-29
18.4.7	Docking System Passive Test (Systems A&B)	18-29
18.5	Telecommunications System	18-30
18.5.1	DM Speaker Box Operation	18-30
18.5.2	DM TV Checkout	18-31
18.5.3	TV Crew Transfers (TBD)	18-31
18.5.4	Soyuz Operations	18-32
18.6	Mechanical Systems	18-35
18.6.1	DM Hatch Opening (2 & 3)	18-35
18.6.2	DM/Soyuz Umbilical Installation and Removal	18-37
19.0	ABORT PROCEDURES	19-1
19.1	LES Abort Modes	19-1
19.1.1	Mode 1A LES Abort (00:00 - 01:01)	19-4
19.1.2	Mode 1B LES Abort (01:01 - 01:48)	19-11
19.1.3	Mode 1C LES Abort (01:48 - 02:51)	19-20

APOLLO-SOYUZ TEST PROJECT (ASTP)
OPERATIONS HANDBOOK

Section	Title	Page
19.2	RCS/SPS Abort Modes II, III, IV	19-30
19.2.1	Mode II RCS Abort (02:51 to Mode IIIA or IV)	19-31
19.2.2	Mode IIIA SPS Abort (09:28 to Mode IIIB)	19-35
19.2.3	Mode IIIB SPS Abort (Mode IIIA to Insertion)	19-40
19.2.4	Mode IV SPS Abort (09:41 to Insertion)	19-45
20.0	UNDOCKED EMERGENCY PROCEDURES	20-1
20.1	Pad Emergency Procedures	20-1
20.1.1	Rapid Hatch Opening	20-1
20.2	Undocked Flight Emergency Procedures	20-2
20.2.1	Fire/Smoke in CM During Boost	20-2
20.2.2	Fire/Smoke in CM - Orbital Operations	20-2
20.2.3	Fire/Smoke in CM During Entry	20-6
20.2.4	Not Applicable	20-7
20.2.5	Contamination in CM	20-7
20.2.6	Contamination in Suit (Suite: Crewman)	20-8
20.2.7	LET Fails to Jettison	20-9
20.2.8	Emergency Safe of Apex Cover Jettison	20-10
20.2.9	One Y Strut Will Not Fully Extend and Lock	20-12
20.2.10	SM RCS Jet Failed On	20-12
20.2.11	CM RCS Fails to Pressurize or Feed Propellant	20-13
20.2.12	FC 1 (2, 3) C&W Light On	20-14
20.3	Postlanding Emergency Procedures	20-15
20.3.1	Fire/Smoke in CM During Postlanding	20-15
21.0	DOCKED EMERGENCY PROCEDURES	21-1
21.1	CSM DM Docked Emergency Procedures	21-1
21.1.1	Forward Hatch Cannot Be Re-Installed	21-1
21.1.2	Fire/Smoke in CM-Docked Operations (TBD)	21-7
21.1.3	Time Critical Undocking and Separation (TBD)	21-7
21.1.4	Abnormal Vehicle Dynamics (TBD)	21-7
21.2	DM/Soyuz Docked Emergency Procedures	21-7
21.2.1	Time Critical Undocking & Separation	21-7
21.2.2	Fire, Smoke and Contaminants/DM at Soyuz Pressure (TBD)	21-8
21.2.3	Fire, Smoke, Contaminants/DM at CM Pressure (TBD)	21-8
21.2.4	Rapid Loss of DM Pressure	21-9
Appendix A	CSM Switch Configuration	A-1
Appendix B	DM Switch Configuration	B-1

APOLLO-SOYUZ TEST PROJECT (ASTP)
OPERATIONS HANDBOOK

STA/T STEP	PROCEDURE	PANEL	REMARKS
1.0	BACKUP CREW PRELAUNCH CHECKS		
	<p>Prelaunch procedures consist of operational and configuration checks performed by backup flight crew prior to ingress of prime crew. Procedures have been sequenced so they can be more easily compared with other prelaunch documents. In order to keep them closely aligned, redundant switch settings may appear in more than one area and GDC align procedures have been repeated wherever necessary. It is assumed that a complete prelaunch checkout, including loose gear stowage, has been performed by ground support personnel, prior to backup crew ingress into command module, and that all systems are in an active configuration as required at time of ingress. Spacecraft suit circuit shall have been purged and oxygen content verified to be 95% minimum. Backup crew will utilize facility headsets until service structure is clear of vehicle, as there will be no VHF AM or S BAND transmission until that time. Refer to Appendix A for cabin switch/control position prior to backup crew cabin ingress.</p>		
1.1	C&WS STATUS CHECK		
CP	C/W NORM - NORM	2	
	C/W CSM - CSM		
	C/W PWR - 2 [pause at off (ctr) at least 1 sec]		
ALL	MASTER ALARM pb/lt (3) - on, push	1,3,122	Excessive switching speed will cause temporary loss of both power supplies, and alarm reset capability.
CP	C/W PWR - 1 [pause at off (ctr) at least 1 sec]	2	Excessive switching speed will cause temporary loss of both power supplies, and alarm reset capability.
ALL	MASTER ALARM pb/lt (3) - on, push	1,3,122	1 position is momentary.
CP	C/W LAMP TEST - 1 (hold)	2	
AC	MASTER ALARM pb/lt - on	1	
CP	1h C/W lt (18) - on	2	
	C/W NORM - BOOST		
AC	MASTER ALARM pb/lt - out	1	
CP	C/W NORM - NORM	2	
AC	MASTER ALARM pb/lt - on	1	

1.1 C&WS STATUS CHECK

NORMAL/BACKUP

APOLLO-SOYUZ TEST PROJECT (ASTP)
OPERATIONS HANDBOOK

STA/T STEP	PROCEDURE	PANEL	REMARKS
CP	C/W LAMP TEST - 2 (hold)	2	<p>2 position is momentary.</p> <p>If C/W NORM switch not in ACK position, SUIT COMPRESSOR light will remain on until compressor is activated.</p> <p>SUIT COMPRESSOR light will go out.</p> <p>A 5/32-inch hex driver is required.</p> <p>GTA switch is used during ground operations only. Setting switch on (up) allows EMS calibration for zero G condition. Switch must be set off (down) and door closed before flight.</p>
AC	MASTER ALARM pb/lt - out	1	
CP	lh C/W lt (18) - out	2	
DF	MASTER ALARM pb/lt - on	3	
CP	rh C/W lt (18) - on	2	
	C/W LAMP TEST - rel	3	
DF	MASTER ALARM pb/lt - out	2	
CP	rh C/W lt (17) - out	2	
	C/W NORM - ACK		
	1.2 EMS PRELAUNCH TESTS		
AC	1 Initial EMS Prep EMS FUNC - OFF	1	
	<u>CAUTION</u> If SPS THRUST lt on, a ground exists on one or both AV THRUST circuits.		
	cb EMS (2) - close Open EMS GTA cover	8	
	GTA sw - on (up)	1	
	EMS MODE - STBY		

EMS PRELAUNCH TESTS

APOLLO-SOYUZ TEST PROJECT (ASTP)
OPERATIONS HANDBOOK

STA/T STEP	PROCEDURE	PANEL	REMARKS						
AC	1								
2	EMS FUNC - AV (CW) Adj alphanumeric brightness (option) Wait 5 sec								
3	GTA Null Adj EMS MODE - NORM Adj GTA null adj until AV/RNG least significant digit changes <1 per 10 sec								
4	EMS FUNC - AV SET (CW) Slew AV ind to +1586.8		<p>AV/EMS SET switch used both for slewing G-V scroll and for setting AV/RNG indicator. Slew speeds executed by AV/EMS SET switch are as follows:</p> <table border="1" data-bbox="465 946 569 1840"> <thead> <tr> <th data-bbox="465 946 499 1035">G-V Display Ft/Sec of Scroll</th> <th data-bbox="465 1035 499 1167">AV RNG Indicator Ft/Sec or Nautical Miles</th> </tr> </thead> <tbody> <tr> <td data-bbox="499 946 534 1035">Slow (soft stop) INCR or DECR 30 ft/sec/sec = 0.0164 in./sec</td> <td data-bbox="499 1035 534 1167">0.25/sec</td> </tr> <tr> <td data-bbox="534 946 569 1035">Fast (hard stop) INCR or DECR 480 ft/sec/sec = 0.263 in./sec</td> <td data-bbox="534 1035 569 1167">127.5/sec</td> </tr> </tbody> </table> <p data-bbox="569 946 604 1840">For negative numbers AV/RNG indicator will display a minus sign. No sign will appear for positive numbers. Light should be fully illuminated, indicating that both filaments are functioning.</p>	G-V Display Ft/Sec of Scroll	AV RNG Indicator Ft/Sec or Nautical Miles	Slow (soft stop) INCR or DECR 30 ft/sec/sec = 0.0164 in./sec	0.25/sec	Fast (hard stop) INCR or DECR 480 ft/sec/sec = 0.263 in./sec	127.5/sec
G-V Display Ft/Sec of Scroll	AV RNG Indicator Ft/Sec or Nautical Miles								
Slow (soft stop) INCR or DECR 30 ft/sec/sec = 0.0164 in./sec	0.25/sec								
Fast (hard stop) INCR or DECR 480 ft/sec/sec = 0.263 in./sec	127.5/sec								
5	EMS FUNC - AV TEST (CW) SPS THRUST lt - on AV ind - decr (10 sec)								

1.2 EIS PRELAUNCH TESTS

NORMAL/BACKUP

APOLLO-SOYUZ TEST PROJECT (ASTP)
OPERATIONS HANDBOOK

STA/T STEP	PROCEDURE	PANEL	REMARKS
AC	<p>SPS THRUST lt - out (at ΔV -0.1 fps) ΔV ind - stops at -0.1 to -41.5 fps EMS MODE - STEY</p>	1	
6	<p>EMS FUNC - EMS TEST 1 (CCW) (wait 5 sec) EMS MODE - NOPX (wait 10 sec)</p>		<p>Test 1 checks lower trip point of .05 G comparator. Ten seconds should be allowed to verify no malfunc- tions. No other light should come on before or after 10 seconds.</p>
	<p>.05 G lt - out SPS THRUST lt - out Lift vector dn lt - out Lift vector up lt - out EMS ind - 0.0 m</p>		<p>EMS scroll reverse slew capability is limited to one inch.</p>
7	<p>EMS FUNC - EMS TEST 2 (CCW) .05G lt - on (all others out) Wait 10 sec All other EMS lights out</p>		<p>Test 2 checks upper trip point of .05 G comparator. No other light should come on before or after 10 seconds.</p>
8	<p>EMS FUNC - EMS TEST 3 (CCW) .05 G lt - on Lift vector dn lt - on (10 sec after .05 G lt) Set EMS ind to 56.0+0.0 m</p>		<p>Test 3 checks corridor verification circuitry associated with lift vector down light ($G < .2$). Light should be fully illuminated, indicating that both filaments are functioning. For negative numbers PMG indicator will display minus sign in most significant digit. No sign will appear for positive numbers.</p>

EMS PRELAUNCH TESTS

APOLLO-SOYUZ TEST PROJECT (ASTP)
OPERATIONS HANDBOOK

STA/T STEP	PROCEDURE	PANEL	REMARKS
AC	<p>9 EMS FUNC - EMS TEST 4 (CCW)</p> <p>.05 G lt - on (all others out) G-V trace (during 10-sec period) within test pattern After 10 sec, G-V trace stops at lower right corner of test pattern RMG ind (during 10-sec period) counts toward zero After 10 sec, stops at 0.0+0.2 MM</p>	1	<p>Test 4 checks range-to-go integrator circuits, range-to-go indicator, G-servo circuits, and G-V plotter.</p>
10	<p>EMS FUNC - EMS TEST 5 (CCW)</p> <p>.05 G lt - on Lift vector up lt - on (10 sec after .05 G lt) RMG ind - resets to 0.0 MM Scribe traces vert line ≈ 9 G to 0.28+0.1 G & stops (trace within test pattern)</p>		<p>Test 5 checks corridor verification circuitry associated with lift vector up light (G > .2). Enables slewing scroll to start of entry pattern. After scroll is set to <37K fps, it is not permissible to return EMS FUNC switch to EMS TEST 5 position (range integrator and scroll sync would be lost).</p>
11	<p>Slew scroll until stylus is at 0.28 G tolerance step of ground test pattern 1 & verify ΔV instructions are visible</p>		

EMS PRELAUNCH TESTS

1.2

NORMAL/BACKUP

APOLLO-SOYUZ TEST PROJECT (ASTP)
OPERATIONS HANDBOOK

STA/T STEP	PROCEDURE	PANEL	REMARKS
AC 12	<p>EMS FUNC - RING SET (CCW) Scribe traces vert line from 0.28 G to 0.0+0.1 G & stops EMS MODE - STBY All lts - out</p>	1	
13	<p>EMS FUNC - OFF (CCW)</p> <p style="text-align: center;"><u>WARNING</u></p> <p>GTA sw is for ground tests only & must be set off (down) & door closed for proper flt oper of EMS.</p>		
	GTA sw - off (down) Close GTA cover		A 5/32-inch hex driver is required.
1.3	<p>GLYCOL LOOP CHECKS</p>		Secondary glycol loop is checked and activated prior to EPE (MA014) experiment cool down.
CP	<p>Sec Gly Loop Check & Activation GLY TO RAD SEC vlv - NORM ECS IND sel - SEC SEC COOL PUMP - AC1 RAD SEC IN TEMP ind - 60°-97°F RAD SEC OUT TEMP ind - 60°-70°F (pegged) SEC GLY EVAP OUT TEMP ind - 60°-75°F (pegged) SEC GLY EVAP STM PRESS ind - 0.25 psia (pegged) SEC GLY DISCH PRESS ind - 39-52 psig SEC ACCUM QTY ind - 30-60%</p>	377 2	
	SEC COOL PUMP - AC2 SEC GLY DISCH PRESS ind - 39-52 psig		Range shown is for gauge. Comparable corrected range used for prelaunch redlines is 40-80%.

GLYCOL LOOP CHECKS

APOLLO-SOYUZ TEST PROJECT (ASTP)
OPERATIONS HANDBOOK

STA/T STEP	PROCEDURE	PANEL	REMARKS
CP	ECS IND sel - PRIM GLY TO RAD SEC vlv - BYP EPE COOLING vlv - COOL (tool E)	2 377 165	German electrophoresis experiment (MA014). For storage refer to NASA document (TEL). GSE flow must be temporarily interrupted (3 minutes maximum) for this check. Range shown is for gauge. Comparable corrected range used for prelaunch redlines is 25-55%.
DP	Prim Gly Loop Check PRIM GLY DISCH PRESS ind - 39-52 psig	2	
CP	PRIM ACCUM QTY ind - 25-50% GLY PUMPS - 1 AC1 PRIM GLY DISCH PRESS ind - 39-52 psig RAD FLOW CONT PWR - PWR RAD FLOW CONT AUTO - 2 ECS RAD tb - 2	4 2	2 indicates No. 2 flow proportioning valve controlling flow. Gray indicates No. 1 flow proportioning valve controlling flow.
AC	RAD FLOW CONT AUTO - 1 until ECS RAD tb gray (~20 sec) then AUTO	7	
CP	ECS RAD tb - gray RAD FLOW CONT PWR - off (ctr) DIRECT 02 vlv - OPEN (CCW), adj for 02 FLOW ind - 0.4+0.1 lb/hr	2	
DP	1.4 STANDBY INVERTER (NO. 3) CHECK FC 2 & 3 PUMPS - AC1 AC2 RSET - OFF INV 3 - MIB INV 2 AC2 - OFF INV 3 AC2 - on (up)	5 3	To maintain continuous power to the FC pumps during inverter check. Rapid performance of inverter switching sequence may initiate MASTER ALARM ph/it when alternate inverter is connected to bus.

1.4

STANDBY INVERTER (NO. 3) CHECK

NORMAL/BACKUP

APOLLO-SOYUZ TEST PROJECT (ASTP)
OPERATIONS HANDBOOK

STA/T STEP	PROCEDURE	PANEL	REMARKS
DP	AC2 RSET - RSET	3	RSET position is momentary. Positioning AC1 or 2 RSET switches to RSET and releasing ensures a MASTER ALARM light and tone. Positioning AC1 or 2 RSET switches to center will cause random activation of MASTER ALARM lights and tone.
CP,DP	MASTER ALARM pb/lt (2) - on (push)	3,122	SUIT COMPER C/W light will come on while MASTER ALARM pb depressed.
CF	C/W lts (36) - out	2	
DP	AC IND sel - BUS 2, ØA, B, C AC VOLTS ind - 113-117 vac AC2 RSET - OFF INV 3 AC2 - OFF INV 2 AC2 - on (up)	3	Rapid performance of inverter switching sequence may initiate MASTER ALARM pb/lt when alternate inverter connected to bus.
DP,CP	AC2 RSET - RSET		RSET position is momentary. Positioning AC1 or 2 RSET switches to RSET and releasing ensures a MASTER ALARM light and tone. Positioning AC1 or 2 RSET switches to center will cause random activation of MASTER ALARM lights and tone.
CP	MASTER ALARM pb/lt (2) - on (push)	3,122	
DP	C/W lts (36) - out INV 3 - OFF	2 3	
AC	AC IND sel - BUS 1 & 2, ØA, B, C AC VOLTS ind - 113-117 vac 1.5 FLOAT BAG CHECK FLOAT BAG (all) - OFF cb FLOAT BAG (all) - close FLOAT BAG (all) - VENT cb FLOAT BAG (all) - open	8	Inverter 1 powering a-c bus No. 1 and inverter 2 powering a-c bus No. 2. Lever lock. Lever lock.

FLOAT BAG CHECK

APOLLO-SOYUZ TEST PROJECT (ASTP)
OPERATIONS HANDBOOK

STA/T STEP	PROCEDURE	PANEL	REMARKS
CP	<p>1.6 LHEB ECS VALVE STATUS</p> <p>GLY TO RAD SEC vlv - BYP (verify) PRIM ACCUM FILL vlv - OFF PRIM GLY ACCUM vlv - open (CCW), then 1/8 CW</p> <p>Y-Y strut - retract</p> <p>Open coolant cont atten pnl</p> <p style="text-align: center;"><u>WARNING</u></p> <p>SUIT FLOW RELF vlv must remain OFF throughout msn or swelling of CO2-odor absorber filters may result.</p> <p>SUIT FLOW RELF vlv - OFF GLY EVAP IN TEMP vlv - MIN (CCW) SUIT HT EXCH SEC GLY - FLOW EVAP H2O CONT (2) - AUTO H2O ACCUM (both) - RMTE Close coolant cont atten pnl Y-Y strut - extend & lock in place Open CO2 cstr atten pnl CO2 CSTR DIVERT vlv - ctr Close CO2 cstr atten pnl MI REG (2) - open H2O/GLY TK sel (2) - BOTH</p>	<p>377 379 378</p>	<p>One-eighth clockwise will prevent damage to valve in subsequent checks.</p> <p>Y-Y strut to be retracted to provide attenuation panel access.</p> <p>Covers panel 382.</p>
		382	Covers CO2 canisters.
		350	
		351	

1.6

LHEB ECS VALVE STATUS

NORMAL BACKUP

APOLLO-SOYUZ TEST PROJECT (ASTP)
OPERATIONS HANDBOOK

STA/T STEP	PROCEDURE	PANEL	REMARKS
CP	EMER CAB PRESS sel - OFF	351	Servicing fitting is plugged.
	CAB REPRESS vlv - OFF (ccw)	352	
	WASTE TK SERV vlv - CLOSE		Potable water chlorination port capped.
	PRESS RELF sel - HELF		
	POT TK IN vlv - as req		Actual pressure differential across forward hatch will be 0.0 psid. However, indicator specification allows 0.025 psid gage error.
	WASTE TK IN vlv - AUTO		
	PRESS EQUAL vlv - CLOSE	Fwd Hatch	Drinking water unavailable during launch hold periods.
	Actr handle sel - stowed		
	Actr handle rel - locked		Connector covered.
	TUHL VENT vlv - DM/CM AP	12	
	DM/CM AP ind - 0.0 psid		Guarded.
	SUIT FLOW vlv (3) - FULL FLOW	300, 301, 302	
	Cab ht exch louvers - ctr	303	
	PRIM CAB TEMP vlv - COLD (cw)		
	SEC CAB TEMP vlv - MAX COOL (CW)		
	DRINK H2O SUP vlv - OFF	304	
	H2O gun probe safety - push lock		
	H2O gun probe fire extg vlv (red) - lock closed		
1.7	LEB & TIMER PANEL 306	100	
	UTIL PWR - OFF		
	FLOOD DIM - 1		
	FLOOD FIXED - OFF		
	G/N OPT PWR - OFF		
	G/N IMJ PWR - on (up)		
	G/N LTS - AC1		
	NUMERICS LTS - as desired		
	INTGL LTS - as desired		

LEB & TIMER PANEL 306

APOLLO-SOYUZ TEST PROJECT (ASTP)
OPERATIONS HANDBOOK

STA/T STEP	PROCEDURE	PANEL	REMARKS
CP	<p>FLOOD LTS - OFF (CCW) MSN TMR - RSET MSN TMR ind - zero MSN TMR - START MSN TMR ind - counting up (verify) MSN TMR HRS - ctr MSN TMR MIN - ctr MSN TMR SEC - ctr EVNT TMR START - STOP, then ctr EVNT TMR RSET - RSET EVNT TMR ind - zero EVNT TMR MIN - ctr EVNT TMR SEC - ctr SYS TEST (2) - 5C SYS TEST ind - 1.3-5.0 vdc</p> <p>SYS TEST (2) - 6C, 7C, 8C</p> <p>SYS TEST ind - 1.3-3.7 vdc SYS TEST (2) - 3E CM RCS HRS - OFF WASTE H2O DUMP - HTR A URINE DUMP - HTR A</p> <p><u>CAUTION</u> OPT ZERO sw must not be moved during prelaunch or inadvertent jett of optics covers could occur.</p> <p>OPT ZERO - ZERO OPT TELTRUN - SLAVE TO SXT</p>	<p>100 306</p> <p>101</p> <p>122</p>	<p>RSET position is momentary. Mission timer will reset to zero and count up at launch.</p> <p>RSET position is momentary.</p> <p>Equivalent to +40° to +150°F nominal SPS engine valve body temperature. Equivalent to +40° to +110°F nominal SPS oxidizer feed line, SPS fuel checks valve, and SPS oxidizer tank outboard temperatures. Monitors battery relay bus voltage during launch.</p> <p>6.1.3, note 4g.</p>

LEB & TIMER PANEL 306

1.7

NORMAL/BACKUP

APOLLO-SOYUZ TEST PROJECT (ASTP)
OPERATIONS HANDBOOK

STA/T STEP	PROCEDURE	PANEL	REMARKS
CP 1.8	RHEE & PANEL 601		
	C/W TONE ADJUST (3) - as desired	223	
	cb pnl 225 - all closed	225	
	cb pnl 226 - all closed except	226	Prevents exterior spotlight door initiator from operating during launch.
	cb COAS/TUNL LTG MNB - open		
	cb FC RAD BAT RLY (3) - open		
	cb pnl 229 - all closed except	229	Prevents premature main parachutes release.
	cb MW REL (2) - open		
	cb PYRO BUS A BAT BUS A - open		
	cb PYRO BUS B BAT BUS B - open		
	cb UVA EXP MNB - open	230	
	cb UVA COVER MNB - open		
	UVA PWR - OFF		
	UVA LAMPS - OFF		
	UVA COVER - ctr		
	UVA COVER tb - gray		
	ETE PWR - OFF		
	cb pnl 250 - all closed except	250	
	cb MW BUS INTERCONNECT (2) - open		
	OVBD DRAIN vlv - OFF	251	
	BAT VENT vlv - VENT	252	
	WASTE STOW VENT vlv - VENT		
	REPRESS O2 VLV - CLOSE	601	Guarded.
1.9	ORDEAL SWITCH POSITION CHECK		Assumes that ORDEAL box has been interconnected between FDAIs and EDA during installation, and that prime or backup crews will not be required to connect or disconnect ORDEAL cables to stow or unstow ORDEAL.

ORDEAL SWITCH POSITION CHECK

1.9



APOLLO-SOYUZ TEST PROJECT (ASTP)
OPERATIONS HANDBOOK

STA/T STEP	PROCEDURE	PANEL	REMARKS
	<p style="text-align: center;"><u>CAUTION</u></p> <p>Before ORDEAL is stowed, or when not being used (whether EARTH/LUNAR sw is in PWR OFF or not), FDAI 1 & 2 sw must be in INRTL. Otherwise, pitch inertial att cannot be displayed by FDAI ball.</p>		
AC	<p>FDAI sw (both) - INRTL EARTH/LUNAR - PWR OFF ALT SET cont - as req</p>	13	<p>This value to be determined from planned nominal insertion altitudes for each particular mission.</p>
	<p>LTG - OFF MODE - HOLD/FAST SLEW - ctr</p>		
	<p>1.10 LH COUCH CHECKS</p>		
	<p>THC & RHC 2 - LOCKED</p>		<p>It is possible to actuate THC clockwise or counter-clockwise while locked.</p>
CP	<p>LH ECS Vlv Stat SRG TK RELF vlv - open (CW) PLVC sw - NORM DEMAND REG sel - BOTH SUIT TEST vlv - OFF SUIT RETURN vlv - close (push) PRIM GLY TO RAD - norm (in) CAB PRESS RELF vlv (2) - BOOST/ENWTR (safety latch off) GLY RSVR IN vlv - OPEN</p>	<p>375 376 380 325 326</p>	<p>For ground checks, CAB PRESS is the equivalent of flight term CAB PRESS RELF.</p>

LH COUCH CHECKS

APOLLO-SOYUZ TEST PROJECT (ASTP)
OPERATIONS HANDBOOK

STA/T STEP	PROCEDURE	PANEL	REMARKS
CP	GLY RSVR OUT vlv - OPEN GLY RSVR BYP vlv - CLOSE SM O2 SUP vlv - ON SRG TK O2 vlv - ON REPRESS PKG O2 vlv - ON	326	
AC	LM Side Pnl's COAS PWR - OFF UTIL PWR - OFF PL BCH LT - off (ctr) DYE MARKER - off (down) PL VENT - OFF AUTO RCS (16) - OFF FLOOD DIM - 1 FLOOD FIXLD - OFF HUMERICS LTS - as desired FLOOD LTS - as desired INTGL LTS - as desired SECS LOGIC (both) - OFF SECS PYRO ARM (2) - SAFE cb pnl 8 - all closed except cb CM RCS HTRS (both) - open cb FLOAT BAG (all) - open cb SECS LOGIC (2) - open cb SECS ARM (2) - open cb SPS GAUGING (4) - open EDS PWR - OFF	15	Connector covered. Guarded. Verify safety removed.
		8	Lever lock. Lever lock with lock guard. Prevents inadvertent CM RCS jet activation. Prevents inadvertent activation of float bag compressors and sea dye marker. Prevents inadvertent activation of SECS functions. PUGS deactivated.
		7	

LH COUCH CHECKS

1.10

NORMAL/BACKUP

APOLLO-SOYUZ TEST PROJECT (ASTP)
OPERATIONS HANDBOOK

STA/T STEP	PROCEDURE	PANEL	REMARKS
AC	<p>More than 1 hr of continuous on-time for TVC SERVO PWR 1 or 2 sw may be detrimental to SPS gmb1 actuators.</p> <p><u>CAUTION</u></p> <p>TVC SERVO PWR (both) - OFF FDAI/GPI PWR - BOTH LOGIC 2/3 PWR - on (up) ELEC PWR - ECA SIG CONDR/DR BIAS PWR (both) - AC1 or AC2</p> <p>BMAG PWR (both) - WARMUP</p> <p>LH, ctr MDC & Pnls 600, 601, 602, 603 & 604 Set ALT index - 3300</p> <p>CMC ATT - IMU</p> <p>ACCEL - check (+0.75 - +1.25 G) FDAI SCALE - 5/1 FDAI SEL - 1/2 FDAI SOURCE - CMC ATT SET - GDC MAN ATT ROLL - RATE CMD MAN ATT PITCH - ACCEL CMD</p>	7	<p>Powers RJEC -4 vdc bias power supplies. To provide increased reliability, switches should not be set on same bus.</p> <p>Value obtained from LCC.</p> <p>Normally left at IMU position throughout mission. Selection of GDC position causes total attitude display to be lost on both balls. GDC damage will result if GDC position selected and pitch or yaw rate is >5°/sec, or if GDC yaw Euler angle is >80° and <280°.</p>

LH COUCH CHECKS

APOLLO-SOYUZ TEST PROJECT (ASTP)
OPERATIONS HANDBOOK

STA/T STEP	PROCEDURE	PANEL	REMARKS
AC	<p>MAN ATT YAW - RATE CMD LIM CYCLE - OFF ATT DBD - MIN RATE - HI THC PWR - on (up) RHC PWR NORM (both) - AC/DC RHC PWR DIR (both) - OFF SC CONT - SCS CMC MODE - FREE BRAG MODE (3) - RATE 2 SPS THRUST - NORM LV THRUST (2) - OFF SPS GMBL tw (2) - 0 ATT SET tw (3) - R _____, P _____, Y _____ SCS TVC (2) - RATE CMD GMBL MOT (4) - OFF ATVC GAIN - LO ELS LOGIC - OFF ELS AUTO - MAN CM RCS LOGIC - OFF CM PRPLNT DUMP - OFF CM PRPLNT PURG - OFF IMU CAGE - off (down) EMS ROLL - OFF .05 G sw - OFF Pc IND sw - Pc Pc ind - zero LV IND/GPI sw - GPI TVC GMBL DR (2) - AUTO</p>	1	<p>For ground checks, TRANS CONTR PWR, ROT CONTR PWR NORM, and ROT CONTR PWR DIR are the equivalent of flight terms THC PWR, RHC PWR NORM, and RHC PWR DIR respectively.</p> <p>Lever lock. Guarded.</p> <p>Flight term GMBL MOT is equivalent of ground check term SPS GMBL MOT.</p> <p>Guarded.</p> <p>Guarded. Guarded. Guarded.</p> <p>Required at OFF position until .05 G during entry. OFF position powered by LOGIC 2/3 PWR switch.</p>

LH COUCH CHECKS

1.10

NORMAL/BACKUP

APOLLO-SOYUZ TEST PROJECT (ASTP)
OPERATIONS HANDBOOK

STA/T STEP	PROCEDURE	PANEL	REMARKS
AC	<p>EVENT TMR START - ctr</p> <p>EVENT TMR RSET - up (ctr)</p> <p>EVENT TMR ind - zero</p> <p>EVENT TMR MIN - ctr</p> <p>EVENT TMR SEC - ctr</p> <p>SUIT CAB ΔP ind - >+2.0 in. H20</p>	1	<p>Event Timer not counting. Timer resets and starts counting automatically when lift-off occurs. Resets and starts counting up in event of abort initiation.</p>
CP	<p>O2 FLOW ind - 0.4+0.1 lb/hr (not pegged)</p> <p>PROBE EXTND/REL tb (2) - gray</p> <p>PROBE (3) - OFF</p> <p>UP TLM: CM - ACPT</p> <p>GUIDE RING (2) - off (ctr)</p> <p>STRUCT LATCH (2) - off (ctr)</p> <p>CAPTURE LATCH (2) - off (down)</p> <p>BACKUP PASSIVE (2) - off (ctr)</p> <p>STRUCT LATCH OPEN pb/lt - push, on/ rel, out</p> <p>GUIDE RING EXTEND pb/lt - push, on/ rel, out</p> <p>GUIDE RING CAPTURE pb/lt - push, on/ rel, out</p> <p>PASSIVE pb/lt - push, on/rel, out</p> <p>STRUCT RING CONTACT pb/lt - push, on/ rel, out</p> <p>STRUCT LATCH CLOSE pb/lt - push, on/ rel, out</p> <p>CM RCS PRESS - off (down)</p>	2	<p>Crewman in LH couch performs LH side panel 2 checks.</p> <p>DIRECT O2 valve partially open.</p> <p>Gray indicates probe fully extended or fully retracted.</p> <p>PROBE EXTND/REL switch guarded.</p> <p>UP TLM CM switch should be placed to ACPT only as required during updates.</p> <p>Guarded.</p> <p>Momentary switch.</p> <p>Momentary switch (guarded).</p> <p>Guarded.</p>

LH COUCH CHECKS

APOLLO-SOYUZ TEST PROJECT (ASTP)
OPERATIONS HANDBOOK

STA/T STEP	PROCEDURE	PANEL	REMARKS
CP	<p>RCS Status Check SM RCS PSM He - CLOSE PSM He tb - bp (verify)</p> <p>SM RCS PSM MANF ISOL - ctr PSM MANF ISOL tb - bp (verify)</p> <p>SM RCS QUAD He (4) - ctr SM RCS QUAD He tb (4) - bp (verify)</p> <p>SM RCS QUAD PRIM PRPLNT tb (4) - bp (verify)</p> <p>SM RCS QUAD SEC PRPLNT tb (4) - bp (verify)</p> <p>SM RCS SEC FUEL PRESS (4) - OPEN</p> <p>SM RCS PSM PRPLNT (4) - OPEN</p>	2	<p>Close position is momentary.</p> <p>Barber pole indicates at least one of two redundant helium isolation valves closed in propellant storage module.</p> <p>Positioned to CLOSE prior to backup crew ingress.</p> <p>Barber pole indicates at least one of four (2 oxidizer and 2 fuel) valves closed in the propellant storage module. If gray, ground should be notified.</p> <p>Barber pole indicates at least one of two redundant helium tank isolation valves in each quad closed.</p> <p>Barber pole indicates at least one primary propellant isolation valve (fuel or oxidizer) in each quad closed.</p> <p>Barber pole indicates at least one secondary propellant isolation valve (fuel or oxidizer) in each quad closed.</p> <p>OPEN position is momentary. No talkbacks. ACE confirms helium isolation valves at quad secondary fuel tanks open.</p> <p>OPEN position is momentary. Opening these valves configures the manifold for filling during SM RCS activation.</p>

1.10

LH COUCH CHECKS

NORMAL BACKUP

APOLLO-SOYUZ TEST PROJECT (ASTP)
OPERATIONS HANDBOOK

STA/T STEP	PROCEDURE	PANEL	REMARKS
CP	<p>SM RCS PSM PRPLNT tb (4) - gray</p> <p>SM RCS IND sw - TK PRESS/PTY RCS IND sel - SM A, B, C, D</p> <p>SM RCS PKG TEMP ind - ambient</p> <p>SM RCS He TK PRESS ind - 4100-4200 psia (quad)</p> <p>SM RCS FUEL TK PRESS ind - 192-207 psia (quad)</p> <p>SM RCS PRPLNT QTY ind - 100% (quad)</p> <p>PCS IND sel - PSM</p> <p>SM RCS PKG TEMP ind - zero</p> <p>SM RCS He TK PRESS ind - 4100-4200 psia (FSM)</p> <p>SM RCS FUEL TK PRESS ind - 192-207 psia (PSM)</p> <p>SM RCS PRPLNT QTY ind - TBD (PSM)</p> <p>SM RCS IND sw - MANF PRESS SM RCS FUEL MANF PRESS ind - ambient psia</p> <p>SM RCS OXID MANF PRESS ind - ambient psia</p> <p>CM RCS PRPLNT (both) - on (up)</p>	2	<p>Gray indicates both PSM propellant isolation valve (fuel and oxidizer) in distribution manifolds open at quad.</p> <p>Check each quad in turn.</p> <p>SM RCS package heaters not operated on pad and during ascent to reduce effects of boost heating on package temperature. Temperature <75° or >205°F illuminates SM RCS status lights.</p> <p>Nominal servicing pressure at 70°F.</p> <p>Operational only when RCS IND selector at SM A, B, C, or D.</p> <p>Nominal servicing pressure.</p> <p>Servicing helium pressure on fuel and oxidizer tanks at 70°F. Regulated helium pressure common manifold readout.</p> <p>On position is momentary.</p>

LH COUCH CHECKS

APOLLO-SOYUZ TEST PROJECT (ASTP)
OPERATIONS HANDBOOK

STA/T STEP	PROCEDURE	PANEL	REMARKS
CF	CM RCS PRPLNT tb (both) - gray RCS IND sel - CM 1, 2 CM RCS He TK TEMP ind - 60-90°F CM RCS He TK PRESS ind - 4100-4200 psia CM RCS He MANF PRESS ind - 80-105 psia	2	Gray indicates fuel and oxidizer isolation valves open. Check both CM RCS systems 1 and 2 in turn. Nominal servicing pressure. GSE servicing pressure monitored until system activated. Pressure varies with temperature and ullage. If manifold pressure drops suddenly, indicating a ruptured burst diaphragm, close CM RCS propellant isolation valves and then perform procedure for preheating jets (14.1.4) and 20 minutes. Procedure vents any propellant trapped between propellant isolation valves and jets by energizing jet valve direct coils.
	SM RCS QTY ind - zero		Operational only when RCS IND selector at SM A, B, C, or D.
	SYS TEST (2) - 4B, 5B, 6B, 7B, 8B, 9B SYS TEST ind - ambient (vdc)	101	CM RCS temperature of engine jet valves 12 (-R), 14 (-P), 16 (-Y), 21 (+R), 23 (+P), and 25 (+Y) respectively. SM RCS PSM fuel tank temperature.
	SYS TEST (2) - 10B SYS TEST ind - ambient (vdc) SYS TEST (2) - 1C, 2C, 3C, 4C SYS TEST ind - ambient (vdc) SYS TEST (2) - 3B RCS CMD - ctr	2	SM RCS primary fuel tank temperatures of quads A, B, C & D respectively. Switch last set to OFF (momentary position) prior to backup crew ingress.

LH COUCH CHECKS

1.10

NORMAL BACKUP

APOLLO-SOYUZ TEST PROJECT (ASTP)
OPERATIONS HANDBOOK

STA/T STEP	PROCEDURE	PANEL	REMARKS
CP	RCS TRMFR - SK EDS AUTO - OFF DOCK RING SEP (2) - off (down) CM/SM SEP (2) - off (down) SIVB/DK SEP - off (down) PRELPT DUUP - AUTO 2 ENG OUT SW - AUTO LV RATES SW - AUTO TWR JETT (both) - AUTO LV GUID SW - IU MK REL - off (down) EMER O2 VLV - CLOSE REPRESS O2 VLV - CLOSE REPRESS O2 RELF - open (CW) REPRESS O2 PRESS ind - >865 psig IVA STA O2 SUP - OFF IVA PWR - OFF	2	SM position is momentary. Guarded. Guarded. Guarded. Guarded. Guarded.
DP	1.11 RH COUCH CHECKS RHC 1 - LOCKED RHEB & Pnl 16 C/W INPUTS (43) - ENBL SCI PWR - OFF S5 - off (down) UTIL PWR - OFF cb panel 274 - all open except cb ELECTROPHORESIS (2) - close (verify) TUNIL LTS - OFF EXT RUN LTS - OFF EXT RNDZ/SPOT LTS - off (ctr)	600 601 602 603 604 201 227 16 274	Switch deactivated. Closed after installation of EPE (MA014) experiment.

RH COUCH CHECKS

APOLLO-SOYUZ TEST PROJECT (ASTP)
OPERATIONS HANDBOOK

STA/T STEP	PROCEDURE	PANEL	REMARKS
IP	SUIT COMP (both) - OFF cb Pnl 4 - all closed	4	
	RH MDC PnlS cb FC RAD BAT RLY (all) - close FC RAD (all) - off (ctr)	226 3	Last set to MOPM (momentary) position. Gray indicates fuel cell radiator panel not bypassing flow.
	FC RAD tb (all) - gray		
	cb FC RAD BAT RLY (all) - open FC HPS (all) - on (up) FC PURG (all) - OFF FC REACS (all) - ctr FC REACS tb (all) - gray	226 3	Prevents inadvertent FC radiator effective area reduction. Last set to on (up) (momentary) position. Gray indicates both reactant valves open for each fuel cell.
	SM PWP SOURCE MIA 1 & 3 - OFF, 2 - ctr		Fuel cell management will be monitored by ground crew until the gimbal drive and trim check at which time they will be verified on the main buses by the crew.
	SM PWP SOURCE MIA 1 & 3 tb - bp, 2 tb - gray		Barber pole indicates fuel cells 1 and 3 disconnected from main bus A, gray indicates fuel cell 2 connected to main bus A.
	MIA RSET - ctr SM PWP SOURCE MIB (all) - OFF SM PWP SOURCE MIB tb (all) - bp		Last set to RSET (momentary) position. Barber pole indicates all fuel cells disconnected from main bus B.
	MIB RSET - ctr		Last set to RSET (momentary) position.

RH COUCH CHECKS

APOLLO-SOYUZ TEST PROJECT (ASTP)
OPERATIONS HANDBOOK

STA/T STEP	PROCEDURE	PANEL	REMARKS
DF	FC IND sel - 2 FC H2 FLOW ind - 0.01-0.08 lb/hr FC O2 FLOW ind - 0.1-0.6 lb/hr FC SKIN TEMP ind - 390°-440°F FC COMD EXH TEMP ind - 150°-175°F FC PH HI tb - gray BAT CHG - OFF DC IND sel - SM SOURCE 2 DC AMPS ind - 5-30 amps DC IND sel - MNA, B DC VOLTS ind - 26.5-31 vdc DC IND sel - BAT BUS A, B, BAT C DC VOLTS ind - 31.5-38 vdc DC AMPS ind - <3.0 amps DC IND sel - PYRO BAT A, B DC VOLTS ind - 31.5-38 vdc DC IND sel - MNA Dual Inv Stat Check INV 1 - MNA INV 2 - MMB INV 3 - OFF INV 1 AC1 - on (up) INV 2 AC1 - OFF INV 3 AC1 - OFF AC1 RSET - ctr INV 1 AC2 - OFF INV 2 AC2 - on (up) INV 3 AC2 - OFF AC2 RSET - ctr AC IND sel - BUS 1 & 2, ØA, B, C AC VOLTS ind - 113-117 vac	3	<p>Flow limits are proportional to individual fuel cell currents and can be approximated by fuel cell H2 flow \approx (amps x 2.5)/1000, and fuel cell O2 flow \approx (amps x 2.0)/100. GSE is supplying most of the SC power.</p> <p>Gray indicates normal pH factor normal.</p> <p>MNB powered by GSE.</p> <p>Switch position verification only. If switch positions must be changed, refer to 5.3.8, step a.</p>

RH COUCH CHECKS

1.11

NORMAL/BACKUP

APOLLO-SOYUZ TEST PROJECT (ASTP)
OPERATIONS HANDBOOK

STA/T STEP	PROCEDURE	PANEL	REMARKS
DP	<p>SPS Stat Checks SPS TEMP IND sw - He PNL, OXID LN SPS TEMP ind - 100°F max</p> <p>SPS FUEL PRESS ind - 170-195 psia SPS OXID PRESS ind - 170-195 psia</p> <p>SPS PRESS IND sw - He, N2A, N2B SPS He PRESS ind - 3300-3900 psia SPS N2 PRESS ind - 2200-2800 psia</p> <p>SPS INJ VLV ind (4) - CLOSE SPS OXID VLV upper tb - gray (verify) SPS OXID VLV lower tb - gray (verify) SPS CTY TEST - ctr OXID FLOW VLV INCR - NORM (verify) OXID FLOW VLV PRIM - PRIM PUG MODE - NORM</p> <p>SPS He VLV tb (both) - bp</p> <p>SPS He VLV (both) - AUTO SPS PRESS IND sw - He VHF ANT - SM LEFT S BD XPNDR - OFF S BD PWR AMPL PRIM - PRIM S BD PWR AMPL HI - off (ctr) S BD MODE VOICE - VOICE S BD MODE PCM - PCM S BD MODE RUG - RNG S BD AUX TAPE - ctr S BD AUX TV - ctr</p>	3	<p>Normal operating temperature is +45° to +75°F. Redline is +40° and +100°F.</p> <p>Normal operating pressure after fuel and oxidizer tank is pressurized with He (after He valve is actuated) is 170-195 psia. GSE servicing pressure is 110 psia.</p> <p>GSE servicing pressure is 3600+50 psia. GSE servicing pressure is 2500+50 psia at 70°F.</p> <p>PUGS deactivated. PUGS deactivated. PUGS deactivated. PUGS deactivated. PUGS deactivated.</p> <p>Barber pole indicates each helium isolation valve is closed.</p>

RH COUCH CHECKS

APOLLO-SOYUZ TEST PROJECT (ASTP)
OPERATIONS HANDBOOK

STA/T STEP	PROCEDURE	PANEL	REMARKS
DE	<p>UP TLM DATA - DATA UP TLM CMD - RSET, then OFF PWR AMPL tb - bp</p> <p>TAPE MOTION tb - bp</p> <p>S BD ANT OMNI A - B S BD ANT OMNI - OMNI VHF AM SOLCH tw (2) - noise +1 VHF AM (2) - off (ctr) VHF AM RCV - off (ctr) VHF BCN - OFF VHF RNG - OFF S BD SOLCH - ENBL FC REAC VLV - NORM H2 PURG LINE HTR - OFF TAPE RCDR PCM - PCM/ANLG TAPE RCDR RCD - RCD</p>	3	<p>Barber pole indicates power is not applied to S-band power amplifier.</p> <p>Barber pole indicates no tape motion.</p> <p>Guarded.</p> <p>Power to switch is provided by the up-data link or the TAPE RCDR FWD switch in FWD position.</p> <p>Allow tape to completely rewind before proceeding. TAPE MOTION talkback is gray when tape is in motion.</p>
CP	<p>TAPE RCDR FWD - REWIND</p> <p>TAPE RCDR FWD - off (ctr)</p> <p>SCE PWF - NORM PMP PWF - NORM PCM BIT RATE - HI PTT BU - NORM MSW TMR - RSET MSW TMR ind - zero</p> <p>MSW TMR - START MSW TMR ind - counting up</p>	2	<p>RSET position is momentary. Crewman in RH couch performs RH side panel 2 checks.</p> <p>Will reset indicator to zero and count up at lift-off, but not abort initiation.</p>

RH COUCH CHECKS

1.11

NORMAL BACKUP

APOLLO-SOYUZ TEST PROJECT (ASTP)
OPERATIONS HANDBOOK

STA/T STEP	PROCEDURE	PANEL	REMARKS
CP	<p>MSN TMR HRS - ctr MSN TMR MIN - ctr MSN TMR SEC - ctr C/W NORM - ACK (verify) C/W CSM - CSM C/W PWR - 1 (verify) C/W LAMP TEST sw - ctr PL VENT VLV - push (lock) CRYO H2 PRESS ind (both) - 225-260 psia O2 PRESS IND sw - TK 1 CRYO O2 PRESS ind (both) - 865-935 psia O2 PRESS IND sw - SURGE TK CRYO O2 PRESS 1 ind - 865-935 psia CRYO H2 QTY ind (both) - verify quantity CRYO O2 QTY ind (both) - verify quantity CAB FAN (both) - OFF H2 HTRS (both) - AUTO O2 HTRS (both) - AUTO H2 FAMS (both) - AUTO ECS IND sel - PRIM RAD PRIM IN TEMP ind - 60°-97°F RAD PRIM OUT TEMP ind - 35°-50°F PRIM GLY EVAP OUT TEMP ind - 35°-45°F PRIM GLY EVAP STM PRESS ind - 0.25 psia (peged) PRIM GLY DISCH PRESS ind - 60 psig max</p>	2	<p>H2 tank 1 and 2 pressures. O2 tank 1 and 2 pressures. CRYO O2 PRESS indicator 1 reads tank 1 or SRG tank pressures depending on CRYO PRESS indicator switch position. O2 SURGE TK pressure. H2 tank 1 and 2 quantities. 28 pounds nominal at 100 percent (each tank). O2 tank 1 and 2 quantities. 320 pounds nominal at 100 percent (each tank).</p>

RH COUCH CHECKS

APOLLO-SOYUZ TEST PROJECT (ASTP)
OPERATIONS HANDBOOK

STA/T STEP	PROCEDURE	PANEL	REMARKS
	<p>SUIT TEMP ind - 45°-55°F CAB TEMP ind - 80°F max SUIT PRESS ind - ~14.9 psia CAB PRESS ind - ~14.7 psia CO2 PP ind - 0.0 mm Hg RAD FLOW CONT AUTO - AUTO ECS RAD tb - Gray RAD FLOW CONT PWR - off (ctr) RAD MAN SEL - RAD 1 RAD PPI: HTR - off (ctr) RAD SEC HTR - OFF SUIT COMP: AP ind - 0.0 psid PPI: ACCUM: QTY ind - 25-50% H2O QTY IND sw - WASTE WASTE H2O QTY ind - <80% SM H2O TK - CLOSE H2O QTY IND sw - POT POT H2O QTY ind - 80% POT H2O PWR - OFF SUIT H2O ACCUM AUTO - ctr SUIT H2O ACCUM ON - ctr SEC COOL EVAP - RSET FOR 58 sec min, then off (ctr) SEC COOL PUMP - AC2 (verify) SEC EVAP H2O FLOW - off (ctr) GLY EVAP IN TEMP - MAX</p>	2	<p>Gray indicates No. 1 flow proportioning valve controlling flow.</p> <p>When switch is powered, by placing RAD FLOW CONT PWR switch to MAN SEL, center position will close all isolation valves.</p> <p>Range shown is for gauge. Comparable corrected range used for prelaunch redlines is 25-55%.</p> <p>Ensures secondary loop steam pressure valve closed.</p>

1.11

RH COUCH CHECKS

NORMAL/BACKUP

APOLLO-SOYUZ TEST PROJECT (ASTP)
OPERATIONS HANDBOOK

STA/T STEP	PROCEDURE	PANEL	REMARKS
CP	Position prim loop stm press vlv GLY EVAP STM AUTO - MAH GLY EVAP STM INCR - INCR for 58 sec min, then DECR for 8.5+0.5 sec	2	INCR AND DECR positions are momentary. Steam pres- sure valve requires 58 seconds from full close to full open.
	GLY EVAP H2O FLOW - off (ctr) CAB PRESS DUMP vlv - close (CW) Side hatch		
	1.12 COMMUNICATIONS CHECK		
DP	1 Comm Activation S BD XPRDR - PRIM S BD PWR AMPL PRIM - PRIM S BD PWR AMPL HI - HI PWR AMPL tb - gray (after 90 sec)	3	Gray indicates power applied to S-band power amplifier.
CP ALL	VHF AM B - DUPLEX S BD ANT ind - >1/3 scale MODE (3) - INTERCOM/PTI VOX SEUS tw (3) - as req VHF FM/PAD COMM (3) - T/R VHF FM/PAD COMM VOL tw (3) - as req PWR (3) - AUDIO/TONE MASTER VOL tw (3) - as req SUIT PWR (3) - on (up) CX/RMTE INTERCOM - T/R	2 9,10,6	
DP ALL	VHF AM' (3) - T/R VHF AM VOL tw (3) - as req S BD (3) - T/R S BD VOL tw (3) - as req AUDIO CONT (3) - NORM VHF RMG - NORM	6 9,10,6	
AC		9	

COMMUNICATIONS CHECK

APOLLO-SOYUZ TEST PROJECT (ASTP)
OPERATIONS HANDBOOK

STA/T STEP	PROCEDURE	PANEL	REMARKS
CP	<p>3. Comm Checks</p> <p>Replace facility headsets with CM headsets</p> <p>Perform comm checks (pad comm, S-band, & VHF AM)</p> <p>Return to facility headset</p> <p>On CF headset & perform S-band & VHF AM comm checks</p> <p>UP TEL: DATA - UP VOICE BU</p> <p>Establish 2-way comm on S-band</p> <p>UP TEL: DATA - DATA</p> <p>S BD AUX TAPE - DN VOICE BU</p> <p>Establish 2-way comm on S-band</p> <p>S BD AUX TAPE - ctr</p> <p>Return to facility headset</p>	<p>9</p> <p>3</p>	<p>CM headsets and CMC adapters have been connected to communication control head prior to backup crew ingress at which time PWR and SUIT PWR switches were OFF (panels 6, 10, and 9).</p> <p>Ground will switch communication channel such that S-band modes and VHF AM may be verified.</p>
ALL	<p>3 At Completion of Comm Checks</p> <p>SUIT PWR (3) - OFF</p> <p>PWR (3) - OFF</p> <p>MASTER VOL tw - 6</p> <p>INTERCOM VOL tw - as req</p> <p>S BD VOL tw - as req</p> <p>VHF AM VOL tw - as req</p> <p>CM/RMTE INTERCOM - OFF</p> <p>Disconnect CM headset & CMC adapter from comm cont head</p> <p>C/W PWR - off (ctr)</p> <p>cb C/W (2) - open</p> <p>AC & DP egress CM</p>	<p>9,10,6</p> <p>10</p> <p>6</p> <p>2</p> <p>5</p>	

COMMUNICATIONS CHECK

I.12

NORMAL/BACKUP

APOLLO-SOYUZ TEST PROJECT (ASTP)
OPERATIONS HANDBOOK

STA/T STEP	PROCEDURE	PANEL	REMARKS
BCP	1.13 VERIFY COUCH CONFIGURATION MDC assist bar - extd & locked Headrests - soft suit position THC armrest in launch position & locked Inbd arm rests - stowed & contr locked Couches - launch/entry position (Y-Y struts extd & locked) Seat pans - 85° position & locked O2/comm umb - stowed Harnesses & restraints - extd & laid aside Couch stab brace - stowed Egress CM		Backup CP (BCP) accomplishes all tasks in 1.13 and 1.14. To eliminate confusion, station callouts for AC and DP locations have not been included.
BCP	1.14 PRIME CREW PRE-INGRESS PROCEDURE Ingress CM S BD PWR AMPL HI - OFF S BD XPHDR - OFF cb C/W (2) - close C/W PWR - 1 C/W MEMORY - RSET MASTER ALARM pb/lt - on, push Perform Pot Water Chlor POT TK IN vlv - OPEN Attach needle assy to inj port Insert chlor ampoule into casing Conn knob assy & rot (CW) until piston contacts ampoule Install ampoule assy on needle assy (push & turn CW)	3 5 2 1,3,122 352	Backup CP re-enters CM. The S-band is powered down to allow GMIL station S-band antenna alignment. RSET is momentary. Performed following launch vehicle propellant loading. Use carry-on sterilization kit for chlorination.

PRIME CREW PRE-INGRESS PROCEDURE

APOLLO-SOYUZ TEST PROJECT (ASTP)
OPERATIONS HANDBOOK

STA/T STEP	PROCEDURE	PANEL	REMARKS
100F	<p>Rot knob (CW) until ampoule is empty (piston bottoms out) Disconnect ampoule assy from needle assy (push & turn CCW) Rot knob (CCW), remove used ampoule Repeat chlor inj steps using another chlor ampoule Repeat chlor inj steps using buffer ampoule (do not remove empty ampoule after inj) Wait 10 min. Then rot inject barrel (CCW) four turns while holding bayonet section in locked position (CW) Rot knob (CCW), remove filled ampoule Remove needle assy from inject port Allow 30-45 min after buffer ampoule injection before proceeding to drink gun and food prep valves cycle, 2.1 DIRECT O2 vlv - OPEN (CCW), adj for O2 FLOW ind - 0.7-0.9 lb/hr SUIT COMPR 1 - AC1 SUIT COMPR AP ind - 0.5-0.9 psid SUIT CAB AP ind - +2.0 in H2O MASTER ALARM pb/lit - push then release c/w lights (all) - out Verify P02 SECS PYRO ARM (2) - SAFE (remove guard) S BD XPNDR - PRIM S BD PWR AMPL HI - HI Ingress LEP for prime crew ingress support</p>	352	<p>Requires ~5-1/2 turns.</p> <p>Needle assembly to remain on inject port.</p> <p>Withdraws one ampoule of water.</p> <p>Verifies that suit compressor or is operating above c/w limits.</p>

PRIME CREW PRE-INGRESS PROCEDURE

1.14

NORMAL/BACKUP

APOLLO-SOYUZ TEST PROJECT (ASTP)
OPERATIONS HANDBOOK

STA/T STEP	PROCEDURE	PANEL	REMARKS
2.0	PRIME CREW PRELAUNCH CHECKS		
2.1	INGRESS AND STATUS CHECKS		
BCP	Drink run & food prep valves cycle Attach H2O sampling container to food prep unit H2O probe	305	
	FOOD PREP HOT H2O vlv - push, rel until 40 oz water withdrawn		
	FOOD PREP COLD H2O vlv - push, rel until 20 oz water withdrawn		
	Remove H2O sampling container from food prep unit and attach to drink gun nozzle		
	DRINK H2O SUP vlv - ON	304	
	Actuate drink gun control until 2-4 oz removed		
	DRINK H2O SUP vlv - OFF		
	POT TK IN vlv - as req at closeout	352	
	WASTE TK IN vlv - AUTO		
	Remove H2O sampling container from drink gun nozzle	304	
	Remove sterilization kit from CM		
2.1.1	AC Ingress to LH Couch		
	Ingress LH couch		
	AC comm umbilical - connect to PGA		
	SUIT PWR - cn (up)	9	
	PWR - AUDIO/TONE		
	1h SUIT FLOW vlv - OFF		
	AC O2 umbilicals - connect to PGA	301	
2.1.1.1	AC INGRESS TO LH COUCH		Connect red to red and blue to blue. Suit hose interconnect removed from CM.

NORMAL/BACKUP

APOLLO-SOYUZ TEST PROJECT (ASTP)
OPERATIONS HANDBOOK

STA/T STEP	PROCEDURE	PANEL	REMARKS
	1h SUIT FLOW vlv - FULL FLOW AC O2 ventilator - shut off and disconnect Assist AC in position; connections and adjustments completed	301	PGA gas connector plugs installed. Ventilator removed from CM. Restraints connected and tightened, and arm rests, torso and life vest adjusted. Helmet protector removed from CM.
AC	CAB FAN (both) - ON Verify switch positions as follows FLOAT BAG (all) - VENT THC - neutral (LOCKED) MAN ATT ROLL - RATE CMD MAN ATT PITCH - ACCEL CMD MAN ATT YAW - RATE CMD SCS TVC (2) - RATE CMD ATVD GAIN - LO	2 8 1	Lever lock.
DP	2.1.2 <u>DP Ingress to RH Couch</u> Ingress RH couch DP comm umbilical - connect to PGA SUIT PWR - on (up) PWR - AUDIO/TONE rh SUIT FLOW vlv - OFF DP O2 umbilicals - connect to PGA	6	Connect red to red and blue to blue. Suit hose interconnect removed from CM.
Tech	rh SUIT FLOW vlv - FULL FLOW DP O2 vent - shut off & disconnect	300	PGA gas connector plugs installed. Ventilator removed from CM.

AC INGRESS TO LH COUCH

APOLLO-SOYUZ TEST PROJECT (ASTP)
OPERATIONS HANDBOOK

STA/T STEP	PROCEDURE	PANEL	REMARKS
DP	Assist PLT in position; connections and adjustments completed Verify the following SPS GAUGING - OFF GLY PUMPS - 1 AC1 VHF ANT - SA LEFT OXID FLOW VLV INCR - NORM MVA RSET - RSET MNB RSET - RSET SPS He VLV (both) - AUTO S BD ANT OMNI A - B S BD ANT OMNI - OMNI VHF BCN - OFF SCE PWR - NORM AC1 RSET - RSET AC2 RSET - RSET	4 3	Restraints connected and tightened, and arm rests, torso and life vest adjusted. PUGS deactivated. PUGS deactivated. RSET position is momentary. RSET position is momentary. RSET position is momentary. RSET position is momentary.
CP	2.1.3 CP Ingress to Center Couch Ingress ctr couch CP comm umbilical - connect to PGA SUIT PWR - on (up) PWR - AUDIO/TONE ctr SUIT FLOW vlv - OFF CP 02 umbilicals - connect to PGA ctr SUIT FLOW vlv - FULL FLOW CP 02 ventilator - shut off and disconnect	10 302	Connect red to red and blue to blue. Suit hose interconnect removed from CM. PGA gas connector plugs installed. Ventilator removed from CM. Restraints connected and tightened, and arm rests, torso and life vest adjusted. Helmet protector removed from CM.
Tech	Assist CP in position; connections and adjustments completed		

2.1.3

AC TO LH COUCH

NORMAL/BACKUP

APOLLO-SOYUZ TEST PROJECT (ASTP)
OPERATIONS HANDBOOK

STA/T STEP	PROCEDURE	PANEL	REMARKS
	Perform final crew verification		
CP	Verify the following PREPLNT DUMP - AUTO C/W NORM - ACK MSN THR - START SUIT COMPR ΔP ind - 0.7-0.9 psid Technician egress CM UP TLM CMD - NORM UP TLM CM - BLOCK VHF FM/PAD COM1 - OFF	2 3 2 10	Helmets, umbilicals, PGA diverter valves and wrist disconnects, foot restraints, and life vests rechecked. PAD COM1 can be used after launch for intercom backup with PAD COMM VOL thumbwheel decreased.
CP	SUIT H2O ACCUM AUTO - 1	2	
BCP	Egress CM		
	<u>2.1.4 EDS Checkout and Countdown Test</u>		
AC	cb EDS (all) - close (verify)	8	
	EDS PWR - on (up)	7	
CP	EDS AUTO - on (up)	2	
AC	ABORT lt operation - verify	1	Crew participation in EDS test directed by ground personnel. Test required ≈30 minutes.
DP	UP TLM CMD - OFF	3	
AC	S BD - OFF INTERCOM - OFF VHF AM - OFF VHF FM/PAD COM1 - OFF	9 6	AC will verify ABORT light operation as it is activated by ground. AC will participate in EDS test on PAD COM1.

AC INGRESS TO LH COUCH

APOLLO-SOYUZ TEST PROJECT (ASTP)
OPERATIONS HANDBOOK

STA/T STEP	PROCEDURE	PANEL	REMARKS
2.1.5	<u>TV Camr Checkout (TBD)</u>		
2.1.6	<u>Cabin Closeout</u>		
-01:40:00	Side hatch closing	Side hatch	
CP	Verify external tool stowed on outside of hatch		
Tech	Remove hatch seal protector		
	Verify safety pin has been removed from actr handle sel		
	Gear box sel - N (neutral)		
	Actr handle set - H (neutral)		
	GM2 vlv handle - push (outboard)		
	Verify piston chamber pressurized		
	XXXXXXXXXXXXXXXXXXXXXXXXXXXXXXXXXXXXX		
Tech	If piston chamber is not pressurized	Side hatch	Squeeze handle to unlock.
	GM2 charge No. 1 - CW (tech)	Side hatch	
	XXXXXXXXXXXXXXXXXXXXXXXXXXXXXXXXXXXXX		
Tech	Hatch open lock - rel	Side hatch	
CP	Push hatch to near closed position		
Tech	Lock pin rel knob - UNLOCK (verify)		
	Hold hatch closed		
	Insert tool B, (handle in 9 o'clock position) into external hatch actuation socket, rotate CW to stops and hold		

2.1.6

AC INGRESS TO LH COUCH

NORMAL/BACKUP

APOLLO-SOYUZ TEST PROJECT (ASTP)
OPERATIONS HANDBOOK

STA/T STEP	PROCEDURE	PANEL	REMARKS
CP Tech	Press and hold LOCK PIN reset button Relax torque & remove tool B		Obtains lock pin engagement. Mechanism should rotate ≈14 degrees CCW because of spring pressure.
CP	LOCK PIN reset button - rel LOCK PIN ind - not extended (rh couch) &/or white ind is opposite white mark (ctr and lh couch) Lock pin rel knob - LOCK (verify)		
Tech	xxxxxxxxxxxxxxxxxxxxxxxxxxxxxxxxxxxx If lock pin is not engaged Insert tool B into external hatch actuation socket & slowly rotate CCW until DP verifies lock pin engagement xxxxxxxxxxxxxxxxxxxxxxxxxxxxxxxxxxxx		
CP	If RED lock pin extended ≈0.5 inch, lock pin has been sheared.		
CP	GN2 press ind - green (verify) Configure hatch for rapid egress Gear box sel - UNLATCH Actr handle sel - U (unlatch) BPC JETT knob - arrow on knob pointing to BPC JETT decal	Side hatch	

NOTE

AC INGRESS TO LH COUCH

APOLLO-SOYUZ TEST PROJECT (ASTP)
OPERATIONS HANDBOOK

STA/T STEP	PROCEDURE	PANEL	REMARKS
-01:35:00	<p>If rapid hatch opening req, refer to 20.1.1.1 Strut unlock lanyard (2) - unstow and attach handle ends to MDC 2 Ground performs cabin purge & hatch leak test Cabin purge to 60% O₂/40% N₂ (launch atmosphere) Ground performs hatch leak test</p> <p style="text-align: center;"><u>CAUTION</u></p> <p>During this check, established SUIT/CAB ΔP should be maintained by DIRECT O₂ valve.</p>		<p>GSE verifies 60:40 ratio. Requires ~20 minutes.</p>
2.1.7	<p><u>Change Launch Azimuth</u> (if necessary)</p>	2	<p>Xsm - X stable member.</p>
CP	<p>Key V78E FL V06 N29 Xsm launch azimuth XXX.XX DEG Key V21E, load new azimuth PRO CAB FAN (both) - OFF</p>		
2.1.8	<p><u>EDS Test Complete</u></p>	9	
-01:21:00	<p>Set controls after test INTERCOM - T/R VHF AM - T/R S BD - T/R</p>		
AC			

AC INGRESS TO LH COUCH

2.1.8

NORMAL/BACKUP

APOLLO-SOYUZ TEST PROJECT (ASTP)
OPERATIONS HANDBOOK

STA/T STEP	PROCEDURE	PANEL	REMARKS
DP	VHF FM/PAD COMM - T/R	6	
AC	EDS PWR - OFF	7	
CP	EDS AUTO - OFF	2	
	2 ENG OUT sw - AUTO (verify)		
	LV RALES sw - AUTO (verify)		
	DC IND sel - BAT C	3	
	DC VOLTS ind - 32.0 vdc min		
	DC IND sel - MNA		
AC	Pc ind - <u> </u>	1	
	-01:13:00		
	2.2 FINAL VERIFICATION AND SYSTEMS CHECKS		
	2.2.1 G&C Verification		
CP	1 Gyro Powerup		
	C/W NORM - NORM	2	
AC	EMAG TEMP lt (both) - out		
	FDAI/GPI PWR - OFF	7	
	ELEC PWR - GDC/ECA		
	EMAG PWR (both) - ON		
	FDAI/GPI PWR - BOTH		
CP	C/W NORM - ACK	2	
AC	2 GDC Alignment		
	FDAI SEL - 1	1	
	FDAI SOURCE - ATT SET		
	ATT SET tw (3) - R 162°, P 90°, Y 0°		

If FDAIs powered when BMAGs come up to speed, rate needles will oscillate full scale.

Nominal angles for a 72° launch azimuth and agree with prelaunch TCP. Only roll affected by variable launch azimuth.

AC INGRESS TO LH COUCH

APOLLO-SOYUZ TEST PROJECT (ASTP)
OPERATIONS HANDBOOK

STA/T STEP	PROCEDURE	PANEL	REMARKS
CP	GDC ALIGN pb - push		
AC	FDAI 1 - errors null		
ATT	SET tw (3) - R 168°, P 84°, Y 354°		
CP	FDAI 1 - errors full scale (verify)	2	These Euler inputs result in 5° body axes errors from alignment angles.
AC	R right, P up, Y right	1	
CP	FDAI 2 - ind same as FDAI 1 (verify)	2	
AC	GDC ALIGN pb - push	1	
CP	FDAI 2 - errors null	2	
ATT	SET tw (3) - R 162°, P 90°, Y 0°	1	
CP	FDAI 2 - errors full scale (verify)	2	
AC	R left, P down, Y left	1	
CP	FDAI SEL - 1		
AC	FDAI 1 - ind same as FDAI 2 (verify)		
GDC	ALIGN pb - push		
CP	FDAI 1 - total att (verify)		
AC	R 162°, P 90°, Y 0°		
	<u>WARNING</u>		
	Sequencers in SECS should be deactivated to preclude an inadvertent abort.		
	SECS PYRO ARM (2) - SAFE (verify)	8	Lever lock.
	SECS LOGIC (both) - OFF (verify)		Lever lock.

2.2.1

AC INGRESS TO LH COUCH

NORMAL/BACKUP

APOLLO-SOYUZ TEST PROJECT (ASTP)
OPERATIONS HANDBOOK

STA/T STEP	PROCEDURE	PANEL	REMARKS															
2.2.2	<u>Gimbal Drive and Trim Check</u>		Verifies trim control and manual (MFVC) control capability of primary and secondary gimbal control system. SPS gimbal angle settings based on CSM c.g. and vary with propellant loading.															
			PITCH and YAW GMBL caution/warning lights (panel 2) indicate overcurrent to gimbal motors. Otherwise, no indication to crew, except for switch selection, that a gimbal motor not operating or auto switchover (THC-CW) has taken place.															
			GMBL POS indicator response opposite to RHC commands as follows:															
			<table border="0"> <tr> <td></td> <td style="text-align: center;"><u>RHC</u></td> <td style="text-align: center;"><u>IND</u></td> </tr> <tr> <td></td> <td>+ Pitch</td> <td>- Pitch</td> </tr> <tr> <td></td> <td>- Pitch</td> <td>+ Pitch</td> </tr> <tr> <td></td> <td>+ Yaw</td> <td>- Yaw</td> </tr> <tr> <td></td> <td>- Yaw</td> <td>+ Yaw</td> </tr> </table>		<u>RHC</u>	<u>IND</u>		+ Pitch	- Pitch		- Pitch	+ Pitch		+ Yaw	- Yaw		- Yaw	+ Yaw
	<u>RHC</u>	<u>IND</u>																
	+ Pitch	- Pitch																
	- Pitch	+ Pitch																
	+ Yaw	- Yaw																
	- Yaw	+ Yaw																
1	Initialization FC on main buses (verify)		Fuel cells are placed on main buses by crew prior to primary TVC check per ground crew instructions.															
DP	SM PWR SOURCE 1 & 2 MNA - ctr, 3 MNA - 3 OFF		Gray indicates fuel cells 1 and 2 connected to main bus A; barber pole indicates fuel cell 3 disconnected from main bus A.															
	SM PWR SOURCE MNA tb - 1 & 2 gray, 3 bp		Barber pole indicates fuel cells 1 and 2 disconnected from main bus B; gray indicates fuel cell 3 connected to main bus B.															
	SM PWR SOURCE 1 & 2 MNB - OFF, 3 MB - ctr																	
	SM PWR SOURCE MNB tb - 1 & 2 bp, 3 gray																	

AC INGRESS TO LH COUCH

APOLLO-SOYUZ TEST PROJECT (ASTP)
OPERATIONS HANDBOOK

STA/T STEP	PROCEDURE	PANEL	REMARKS
SP	<p>ME BUS TIE BAT A/C - on (up) Verify bat bus A current incr &/or bat volts decr</p> <p>ME BUS TIE BAT B/C - on (up) Verify bat bus B current incr &/or bat volts decr</p> <p>SCS TVC (2) - RATE CID (verify)</p>	<p>5</p> <p>3</p> <p>5</p> <p>3</p> <p>1</p>	<p>Verification of current increase for appropriate battery bus via DC AMPS indicator (panel 3) confirms successful operation of main bus tie motor switches.</p>
AC	<p>More than 1 hr of continuous on-time for TVC SERVO PWR 1 or 2 sw may be detrimental to SPS gimbal actuators.</p> <p>TVC SERVO PWR 1 - AC1/MNA</p> <p>TVC SERVO PWR 2 - AC2/MNF</p> <p>LV IND/GPI sw - GPI (verify)</p> <p>RHC PWR NORM 2 - AC</p> <p>RHC 2 - ARMED</p> <p>2 Prim TVC Check GMBL MOT P1, Y1 - START</p> <p>Confirm trim cont on inrds SPS GMBL tw (2) - + & -</p> <p>RHC 2 - perform MTVC check</p>	<p>7</p> <p>1</p>	<p>START position is momentary. Start SPS gimbal motors sequentially at ~1-second intervals to avoid power surge. For ground checks, GMBL MOT PITCH or YAW are the equivalent of flight terms GMBL MOT P or Y.</p> <p>Gimbals drive in response to SPS pitch and yaw thumb-wheel movement. Verifies primary gimbal trim control.</p> <p>Gimbals drive in response to RHC movement, and return to set-in values when RHC is neutral. Verifies primary MTVC loops.</p>

AC INGRESS TO LH COUCH

2.2.2

NORMAL/BACKUP

APOLLO-SOYUZ TEST PROJECT (ASTP)
OPERATIONS HANDBOOK

STA/T STEP	PROCEDURE	PANEL	REMARKS
AC	3 See TVC Check SCS TVC (2) - AUTO GIMBL MOT P2, Y2 - START THC - CW Confirm trim control on inds SPS GIMBL tw (2) - + & - RHC 2 - perform MTVC check	1	START position is momentary. Verifies secondary gimbal trim control. Verifies secondary MTVC loops.
DP	4 Auto Switchover Check DC IND sel - S4 SOURCE 3 DC AMPS ind - monitor for amps decr after each No. 2 GIMBL mot shutdown GIMBL MOT P2, Y2 - OFF	3	Decrease verifies gimbal motor shutdown.
AC	Verify no MTVC THC - neut SPS GIMBL tw (2) - P <u> </u> , Y <u> </u>	1	Shut off gimbal motors sequentially to avoid power surge. Shutdown of No. 2 motors first minimizes switching in servo logic.
DP	DC IND sel - S4 SOURCE 1 (2) DC AMPS ind - monitor for amps decr after each No. 1 gimbl mot shutdown GIMBL MOT P1, Y1 - OFF DC IND sel - MHA RHC PWR NORM 2 - AC/DC RHC 2 - LOCKED MN BUS TIE (2) - OFF, then AUTO	3	Gimbals are trimmed to thrusting values. These values are derived from Operational Trajectory, Table VIIIA, and include gimbal offset of <u> </u> in pitch and <u> </u> in yaw from spacecraft axis. Decrease verifies gimbal motor shutdown.
AC	TVC SERVO PWR (both) - OFF LV IND/GPI sw - SIVB	7	Positioned to OFF to allow motor switches to cycle and remove batteries from main buses, then to AUTO in case of a pad abort.

AC INGRESS TO LH COUCH

APOLLO-SOYUZ TEST PROJECT (ASTP)
OPERATIONS HANDBOOK

STA/T STEP	PROCEDURE	PANEL	REMARKS
AC	<p>2.2.3 <u>FDAI Verification</u></p> <p>FDAI SEL - 1/2 FDAI SOURCE - CMC FDAI 1 - total att R X°; P 90°; Y 0°</p> <p>2.2.4 <u>RSI Test & Setup</u></p> <p>EMS ROLL - on (up) GDC ALIGN pb - push & hold ATT SET YAW tw - adj thru 45° angle, observe RSI tracks =45°, then adj until RSI points up GDC ALIGN pb - rel EMS ROLL - OFF Align GDC to IMU</p> <p>FDAI SEL - 1 FDAI SOURCE - ATT SET</p> <p>ATT SET - IMU ATT SET tw (3) - null FDAI 1 err ATT SET - GDC</p> <p>GDC ALIGN pb - push & hold until GDC aligned FDAI SOURCE - CMC FDAI SEL - 1/2</p>	1	<p>FDAI 2 is drifting as a function of earth rate.</p> <p>For ground checks, EMS RAI is the equivalent of flight term RSI.</p> <p>Avoid FDAI gimbal lock region.</p> <p>Ensures that GDC is aligned to actual IMU angles, rather than calculated values. Attitude reference comparison (in orbit) will be more accurate.</p> <p>Constraint: If CMC is on, an overload in IMU resolver circuitry may cause an ICDU oscillation and trigger ISS warning light. FDAI must be used as a null meter in this mode of operation. If not, large errors will result because of impedance mismatch.</p> <p>Enables attitude set inputs to GDC.</p> <p>Enables attitude set inputs to GDC and disables RMAG inputs.</p>

AC INGRESS TO LH COUCH

2.2.4

NORMAL/BACKUP

APOLLO-SOYUZ TEST PROJECT (ASTP)
OPERATIONS HANDBOOK

STA/T STEP	PROCEDURE	PANEL	REMARKS
1.2.5	<u>EMS Preparation</u>		
AC	Set EMS ΔV EMS MODE - STBY (verify) EMS FUNC - ΔV SET Set ΔV ind - 1999.9 fps EMS FUNC - ΔV	1	
-55:00	C/W NORM - BOOST	2	Inhibits master alarm light on panel 1.
CP	UP TLM CMD - NORM	3	
3.2.6	<u>Pad Abort Enable</u>		
	<u>WARNING</u>		
	After pad abort enable, operation of THC - CCW will initiate an abort.		
-44:00	EDS PWR - on (up)	7	
AC	Gear box sel - LATCH	Side hatch	
CP	Actr handle sel - U (unlatch) (verify)		Required to preclude pressure buildup due to DIRECT 02 vlv purge flow.
	Monitor cabin press	2	
	CAB PRESS ind - >15.8 psia	325	
	th CAB PRESS RELF vlv - Dump for 12 sec, then BOOST/ENTRY		
	Shoulder harness - locked	1	
ALL	CM RCS LOGIC - on (up)	8	
AC	cb SECS ARM (2) - close		
	cb SECS LOGIC (2) - close		
	SECS LOGIC (both) - on (up)		Lever lock.

AC INGRESS TO LH COUCH

APOLLO-SOYUZ TEST PROJECT (ASTP)
OPERATIONS HANDBOOK

STA/T STEP	PROCEDURE	PANEL	REMARKS
AC	Report logic arm After GO from STC SECS PYRO ARM (2) - on (up)		STC (Systems Test Conductor). Both lever lock pyro arm switches must be operated. LES pad abort capability enabled; SECS LOGIC and PYRO buses are armed.
	2.2.7 <u>SM RCS Activation</u>		
CP	SM RCS PSM PRPLNT tb (4) - gray (verify)	2	Gray indicates both PSM propellant isolation valves (fuel and oxidizer) in distribution manifolds open at quad.
	PSM He tb - bp (verify)		Barber pole indicates at least one of two helium isolation valves closed in propellant storage module.
	SM RCS PSM MANF ISOL - OPEN		OPEN position is momentary. Opening PSM 1 manifold isolation valves fills the SM RCS manifold with propellant to the engine interface.
	PSM MANF ISOL tb - gray		Gray indicates both fuel and both oxidizer isolation valves open in propellant storage module.
	SM RCS PSM PRPLNT (4) - CLOSE		CLOSE position is momentary.
	SM RCS PSM PRPLNT tb (4) - bp		Barber pole indicates at least one of four PSM pro- pellant isolation valves (fuel or oxidizer) in PSM manifold is closed.
-15:00	SM RCS QUAD He (4) - OPEN		OPEN position is momentary.
to			
-15:00	SM RCS QUAD He tb (4) - gray		Gray indicates both helium tank isolation valves open in each quad.

AC INGRESS TO LH COUCH

2.2.7

NORMAL/BACKUP

APOLLO-SOYUZ TEST PROJECT (ASTP)
OPERATIONS HANDBOOK

STA/T STEP	PROCEDURE	PANEL	REMARKS
CP	<p>RCS IND sel - SM A, B, C, D RCS IND sw - TK PRESS/PTY SM RCS FUEL TK PRESS ind - 192-207 psia (quad) SM RCS QTY ind - 100% (quad) RCS IND sel - PSM RCS IND sw - MANF PRESS SM RCS FUEL MANF PRESS ind - 130-150 psia (distrib) SM RCS OXID MANF PRESS ind - 150-170 psia (distrib) SM RCS SEC FUEL PRESS (4) - CLOSE</p>	2	<p>CLOSE position is momentary. No talkbacks. ACE can confirm helium isolation valves at quad secondary fuel tanks closed.</p> <p>OPEN position is momentary.</p> <p>Gray indicates primary fuel and oxidizer isolation valves open.</p> <p>Gray indicates secondary fuel and oxidizer isolation valves open.</p> <p>Check each quad in turn.</p> <p>SM RCS package heaters not operated on pad or during ascent, to reduce effects of boost heating on package temperature. Temperature <75° or >205° F illuminates SM RCS status lights.</p>
2.2.8	<p><u>SM RCS Status Check</u> RCS IND sel - SM A, B, C, D SM RCS PKG TEMP ind - ambient</p>		

AC INGRESS TO LH COUCH

APOLLO-SOYUZ TEST PROJECT (ASTP)
OPERATIONS HANDBOOK

STA/T STEP	PROCEDURE	PANEL	REMARKS
	SM RCS He TK PRESS ind - 4100-4200 psia (quad) RCS IND sw - TK PRESS/QTY SM RCS FUEL TK PRESS ind - 192-207 psia (quad) SM RCS QTY ind - 100% (quad) RCS IND sel - PSM	2	Nominal servicing pressure at 70°F. Operational only when RCS IND selector at SM A, B, C, or D. Nominal servicing pressure. Servicing helium pressure on fuel and oxidizer tanks at 70°F. Propellant (fuel and oxidizer) distribution manifold pressure same as PSM propellant tank servicing pressure.
	SM RCS PKG TEMP ind - zero		
	SM RCS He TK PRESS ind - 4100-4200 psia (PSM) SM RCS FUEL TK PRESS ind - 130-150 psia (PSM)		
	SM RCS QTY ind - TBD (PSM) SM RCS IND sw - MANF PRESS SM RCS FUEL MANF PRESS ind - 130-150 psia (distrib) SM RCS OXID MANF PRESS ind - 150-170 psia (distrib)		
	RCS IND sw - TK PRESS/QTY RCS IND sel - SMD		
2.3	LAUNCH PREPARATION		
-25:00	Change launch azimuth (if necessary) Key V78E FL V06 N29 Xsm Launch azimuth XXX.XX DEG Key V21E, load new azimuth PRO		Xsm - X stable member.

AC INGRESS TO LH COUCH

2.3

NORMAL/BACKUP

APOLLO-SOYUZ TEST PROJECT (ASTP)
OPERATIONS HANDBOOK

STA/T STEP	PROCEDURE	PANEL	REMARKS
AC	<p>Align GDC to IMU</p> <p>CAB FAN (both) - OFF</p> <p>FDAI SEL - 1</p> <p>FDAI SOURCE - ATT SET</p> <p>ATT SET tw (3) - null FDAI 1 errors</p> <p>ATT SET - GDC</p> <p>GDC ALIGN pb - push & hold until GDC aligned</p> <p>FDAI SOURCE - CMC</p> <p>FDAI SEL - 1/2</p> <p>AUTO RCS A/C ROLL (4) - OFF (verify)</p> <p>AUTO RCS B/D ROLL B1 & B2 - MNA</p> <p>AUTO RCS B/D ROLL D1 & D2 - MNB</p> <p>AUTO RCS PITCH A3 & C4 - MNB</p> <p>AUTO RCS PITCH C3 & A4 - MNA</p> <p>AUTO RCS YAW B3 & D4 - MNA</p> <p>AUTO RCS YAW D3 & B4 - MNB</p> <p>FDAI 1 - total att</p> <p>R <u> </u>, P <u> </u>, Y <u> </u></p> <p>FDAI SCALE - 5/5</p>	1	<p>Ensures that GDC is aligned to actual IMU angles, rather than calculated values. Attitude reference comparison (in orbit) will be more accurate.</p> <p>Constraint: If CMC on, an overload in IMU resolver circuitry may cause an ICPU oscillation and trigger ISS warning light. (Reference ICD MHCL-01325-216.) FDAI must be used as a null meter in this mode of operation. If not, large errors will result because of impedance mismatch.</p> <p>Enables attitude set inputs to GDC.</p> <p>Enables attitude set inputs to GDC and iisables BMAG inputs.</p>
		8	<p>FDAI 2 drifting as a function of earth rate.</p> <p>Roll attitude error is scaled in PLL. Roll full scale deflection will be 20° not 5° as position indicates.</p>
		1	

AC INGRESS TO LH COUCH

APOLLO-SOYUZ TEST PROJECT (ASTP)
OPERATIONS HANDBOOK

STA/T STEP	PROCEDURE	PANEL	REMARKS
AC	RATE - HI THC PWR - on (up) RHC PWR DIP (both) - MNA/MNB CMC MODE - FREE EMAG MODE (3) - RATE 1	1	This position provides most reliable configuration in event a rate gyro fails during boost.
-15:00 DP	RHC 2 - ARMED CTE update/verification DC IND sel - BAT C DC VOLTS ind - 35-37.5 vdc DC IND sel - MNA	3	
CP	EDS AUTO - on (up) 2 ENG OUT sw - AUTO (verify) LV RATES sw - AUTO (verify) RCS CMD - OFF, then ctr	2	
AC	TVC SERVO PWR 1 - AC1/MNA TVC SERVO PWR 2 - AC2/MNB	7	
-10:00 DE	FC REAC VLVS - LATCH	3	
-08:30 CP	SEC COOL PUMP - AC2 (verify)	2	
-08:00	Systems status report		
DP	Astro Launch Operation Voice Check S BD - OFF	6	
AC	VHF AM - OFF	9	
DP	MCCH Voice Check S BD - T/R	6	

Switch last set to OFF (momentary position) prior to backup crew ingress.

AC INGRESS TO LH COUCH

2.3

NORMAL/BACKUP

ASTRO-3000Z "PUSH" PROJECT (ACTP)
OPERATIONS HANDBOOK

START STEP	PROCEDURE	PANEL	REMARKS
CP	<p>VER 44 - VER</p> <p>CEO THRUST - VER; (verify)</p> <p>AL THRUST (2) - VER (verify)</p> <p>To IND SW - Po (verify)</p> <p>Systems 30/31 7: for Launch</p> <p>CP</p> <p>LV Eng lts (all) - ON</p> <p>Astro Launch Operation Notice Check</p> <p>Verify P02</p> <p style="text-align: center;"><u>CAUTION</u></p> <p>Do not press ENTER after keying VT5.</p> <p>If ENTER is pressed, P&C system will receive incorrect liftoff time.</p>	<p>0</p> <p>1</p>	<p>Lever lock.</p> <p>Guarded.</p> <p>Launch vehicle engine lights on T -04:10 minutes.</p>
CP	<p>Key VT5</p>	2	Used in case hardware does not set proper bit (for PLL selection) when umbilical is removed.
-03:00 CP	<p>TAPE RCOR FWD - FWD</p> <p>TAPE MOTION tb - Gray</p>	3	Gray indicates tape in motion.
-04:15 AC	<p>PRIM GLY TO RAD - BYP (pull)</p>	325	Accomplished immediately after GSE water-tilt cool pump deactivated (T -02:15).
CP	<p>PRIM GLY DISCH PRESS ind - 39-52 psig</p> <p>PRIM ACCUM QTY ind - 25-50%</p>	2	Range shown is for gauge. Comparable corrected value used for prelaunch redlines 25-55%.

AC INGRESS TO LH COUCH

APOLLO-SOYUZ TEST PROJECT (ASTP)
OPERATIONS HANDBOOK

STA/T STEP	PROCEDURE	PANEL	REMARKS
-01:15 DP	MN BUS TIE A/C - on (up) Verify bat bus A current incr 3/or bat volts decr MN BUS TIE BAT R/C - on (up) Verify bat bus B current incr 3/or bat volts decr	5 3 5 3	Verification of current increase for appropriate battery bus via DC AMPS indicator (panel 3) confirms successful operation of main bus tie motor switches.
-01:00 AC,DP	VHF FM/PAD COMM (2) - OFF	9,6	PAD COMM can be used after launch for intercom backup with PAD COMM VOL thumbwheel decreased.
-00:45 AC CP AC	VHF AM VOL. tw - incr above normal listening level GDC ALIGN pb - push, hold FDAI 2 total att - no motion GDC ALIGN pb - rel	1 2 1	Compensate for increased noise environment during boost.
	READY FOR IGNITION Refer to Appendix A for cabin switch/ control position at vehicle liftoff.		

AC INGRESS TO LH COUCH

2.3

NORMAL/BACKUP

APOLLO-SOYUZ TEST PROJECT (ASTP)
OPERATIONS HANDBOOK

STA/T STEP	PROCEDURE	PANEL	REMARKS
3. BOOST AND INSERTION			
3.1 BOOST			
-00:03	Ignition		LV engines lights (8) go on at T -4:10 min when S-1B indicating circuits are armed.
AC -00:01	LV ENG lts (all) - out	1	Indicates all eight engines have achieved over 90 percent of rated thrust.
00:00	LIFT OFF lt - on & NO AUTO ABORT lt - out		Time base 1 initiate T +0.2 sec. Additional lift-off cues: Event timer start Voice communications from STDN DSKY displays program 11
	<u>WARNING</u> Do not press LIFT OFF/NO AUTO ABORT pb if LV RATE or any LV ENG lts on.		Manual abort initiation may be required. (Refer to mission rules.)
	xxxxxxxxxxxxxxxxxxxxxxxxxxxxx Liftoff verified If LIFTOFF lt off - push If NO AUTO ABORT lt on - push xxxxxxxxxxxxxxxxxxxxxxxxxxxxx	00:00 MODE 1A	Guarded. Guarded.

3.1

BOOST

NORMAL BACKUP

APOLLO-SOYUZ TEST PROJECT (ASTP)
OPERATIONS HANDBOOK

STA/T STEP	PROCEDURE	PANEL	REMARKS
AC	Verify EVNT TMR ind resets to zero & starts counting up XXXXXXXXXXXXXXXXXXXXXXXXXXXX X EVNT TMR START - START XXXXXXXXXXXXXXXXXXXXXXXXXXXX X	1 RATEC +4°/sec F, Y +20°/sec R	START position is momentary.
CP	Verify MSN TMR ind resets to zero & starts counting up XXXXXXXXXXXXXXXXXXXXXXXXXXXX X MSN TMR - RSET/START XXXXXXXXXXXXXXXXXXXXXXXXXXXX X Verify PLL (auto)	MODE 1A	RSET position is momentary. PLL calculations based on pad-loaded data representing the nominal attitude profile for boost to earth orbit insertion. V82, N32, and N50 available during P11. However, a meaningful display of N32 and N50 is available only during P30 (V82E). V82 should not be selected during P02 or P11 within 5 seconds of lift-off time (this applies to any extended verb which sets bit 1 of flagword 4). V75 inserted in P02 prior to lift-off.

BOOST

APOLLO-SOYUZ TEST PROJECT (ASTP)
OPERATIONS HANDBOOK

STA/T STEP	PROCEDURE	PANEL	REMARKS
CF	VOE N62 VI XXXXX. FPS H dot XXXXX. FPS H pad XXXX.X NM	2	Dynamic, non-flashing display parameters updated throughout ascent. VI = Inertial velocity. H dot = Altitude rate. H pad = Altitude above pad radius.
AC	If LV GUID lt - on, from T +0 to T +01:40 LV GUID sw - CMC	1	
CF	If man cont req Key V46E	2	Allows CMC automatic steering (polynomial guidance) for S-IB stage, and attitude hold commands only, for SIVB stage. Also provides capability of issuing RHC commands via CMC, provided configuration digit in N46 is 3 and V46E is keyed.
AC	+00:10 Roll/Pitch prog report		Disables CMC steering and activates Saturn DAP; RHC provides discrete rate (steering) commands to IU for booster control. The attitude error needles are not designed to provide meaningful "fly to" information in manual mode.
CF	+00:55 Roll prog - complete		
CF	13K' to CAB PRESS ind - starts 15K' decr		Relieves high CM-to-atmosphere ΔP. Assuming that cabin pressure at lift-off is 14.47 to 14.87 psia, the cabin pressure relief valve could begin modulating at 13K'.

BOOST

5.1

NORMAL/BACKUP

APOLLO-SOYUZ TEST PROJECT (ASTP)
OPERATIONS HANDBOOK

STA/T STEP	PROCEDURE	PANEL	REMARKS
<p>XXXXXXXXXXXXXXXXXXXXXXXXXXXXX X If no decr by 25K' rh CAB PRESS RELF vlv - DUMP (safety latch off until CAB PRESS ind - 8 psia, then NORM (safety latch on) If still no decr CAB PRESS DUMP vlv - open (CCW) until CAB PRESS ind - 8 psia, then close (CW)</p>	<p>325 2 325 Side hatch 2</p>	<p>MODE 1A 01:01 MODE 1B</p>	
<p>+01:01</p>	<p>FRPLNT DUMP - RCS CMD MODE 1B - report</p>		
<p>+01:15</p>	<p>MAX. Q</p>		
<p>+01:40</p>	<p>If all engines GO 2 ENG OUT sw - OFF LV RATES sw - OFF EDS AUTO - OFF (report)</p>		<p>Inhibits subsequent 2 engine out av'o abort.</p>
<p>XXXXXXXXXXXXXXXXXXXXXXXXXXXXX X</p>	<p>GND verifies 1 eng out prior to 01:40 Immediately 2 ENG OUT sw - OFF</p>		

BOOST

APOLLO-SOYUZ TEST PROJECT (ASTP)
OPERATIONS HANDBOOK

STA/T STEP	PROCEDURE	PANEL	REMARKS
CP	At 02:00 LV RATES sw - OFF EDS AUTC - OFF (report) XXXXXXXXXXXXXXXXXXXXXXXXXXXXX	2	
+01:48	MODE IC - report (R3 = 16.5 NM)	01:48 MODE IC	
+02:10	CMC BOOST POLYNOMIAL ends Report GO/NO GO for staging		
+02:19	IECO (LV ENG 5, 6, 7, & 8 lts - on) LIFT OFF lt - out (IECO +0.6 sec) OECC (LV ENG 1, 2, 3, & 4 lts - on)	1	Time base 2 initiate T +02:14.6. Inboard engines cutoff.
+02:21			Outboard engines cutoff. Time base 3 initiate T +02:20.6.
+02:23	All eng lts - out		S-IB/SIVB separation.
+02:24	LV ENG 1 lt - on	RATES +10° sec P, Y +20° sec R MODE IC	SIVB engine ignition.
+02:27	LV ENG 1 lt - out		SIVB engine 65 percent rated thrust.
CP	TWR JETT (both) - on (up) (TFF >1+20) (OECC +30 sec, nom or 1 eng out) (OECC +34 sec, 2 eng out)	2 02:51 MODE II	Guarded. On position is momentary.

BOOST

3-1

NORMAL/BACKUP

APOLLO-SOYUZ TEST PROJECT (ASTP)
OPERATIONS HANDBOOK

STA/T STEP	PROCEDURE	PANEL	REMARKS
CP	<p>XXXXXXXXXXXXXXXXXXXXXXXXXXXXX X No tower jett Go to EMER PROCEDURES, 20.2.7 XXXXXXXXXXXXXXXXXXXXXXXXXXXXX X</p> <p>TWR JETT & MODE II - report Activate Saturn DAP</p> <p>V46E, V46E, N62E</p>	2	<p>Activating DAP early will prevent an overspeed if a guidance failure occurs near insertion.</p> <p>V46E keyed twice to properly activate DAP (if not keyed twice, DAP may not be properly activated because of possible unfavorable internal timing).</p>
AC	<p>If man cont req LV GUID sw - CMC</p> <p>MAN ATT PITCH - RATE CMD GLY EVAP STM AUTO - AUTO GLY EVAP H2O FLOW - AUTO</p>	1 2	<p>RHC provides discrete (steering commands to IU for booster control. Attitude error needles not designed to provide meaningful "fly to" information in manual mode.</p>
+02:57	LV guidance init		
+03:25	Guidance good		
+04:00	Report status		
DP			
+05:00	Report status		

BOOST

APOLLO-SOYUZ TEST PROJECT (ASTP)
OPERATIONS HANDBOOK

STA/T STEP	PROCEDURE	PANEL	REMARKS
AC +06:00	Report status		
CP +07:15	SED APT OMNI - D	3	
AC +07:00	Report status LV INI/GPI sw - GPI	1	Ground will monitor LV-FTP during time GPI displayed and will inform crew of any problem.
CP	Monitor main bus voltages during gmb1 mot start	3	
AC +08:00	GMBL MOT (4) - START	1	START position is momentary. Start SPS gimbal motors sequentially at 1-second intervals to avoid power surge.
DF +09:00	Check GPI		
	LV IND/GPI sw - SIVB		
AC +09:41	Report status GO/NO GO for orbit - report		
		09:28 MODE IIIA	
		09:41 MODE IV	
		09:39 MODE IIIIB	
AC +09:41	MODE IV - report		SIVB cutoff must be manually initiated at a TBD time calculated during the boost.
AC	If CMC takeover exercised during thrusting go to backup for SECO		SIVB engine cutoff (auto). Time base 4 initiate. Timebase 4.
CP +09:49	Monitor SECO LV ENG 1 lt - On Begin TB4 SECO - report		

BOOST

NORMAL BACKUP

APOLLO-SOYUZ TEST PROJECT (ASTP)
OPERATIONS HANDBOOK

STA/T STEP	PROCEDURE	PANEL	REMARKS
CP	<p>XXXXXXXXXXXXXXXXXXXXXXXXXXXXX X If late SECO or LV GUID sw - CMC</p>	2	
AC	<p><u>WARNING</u> THC must be returned from CCW position before 3.0 sec or CSM SLA sep will occur.</p>	1	
CP	<p>THC - CCW, return within 1 sec SECO LV ENG 1 lt - on Begin TB4</p>	1	
CP	<p>XXXXXXXXXXXXXXXXXXXXXXXXXXXXX X Rcd from DSKY VI H dot H pad</p>	2	<p>VI = Inertial velocity. H dot = Altitude rate. H pad = Altitude above pad radius.</p>
	<p>MODE IV MODE IIIIB</p>		
	<p>INSERTION XXXXX. FPS XXXXX. FPS XXXXX.X NM</p>		<p>Displays orbital parameters (N44). A meaningful display of N32 and N50 is available only during R30.</p>
	<p>(R30, Orbital Parameters)</p>		

BOOST

APOLLO-SOYUZ TEST PROJECT (ASTP)
OPERATIONS HANDBOOK

STA/T STEP	PROCEDURE	PANEL	REMARKS
01	Key V82E FL V16 N44 Ha Hp TFF	2 XXXX.X NM XXXX.X NM XXBXX MIN-SEC	Ha = Apogee altitude. Hp = Perigee altitude. TFF = Time of free fall to 49.4 NM (300,000 feet).
	Key N50E Splash err Hp TFF	XXXX.X NM XXXX.X NM XYBXX MIN-SEC	Negative for undershoot, positive for overshoot.
	KEY REL FL V16 N44 Ha Hp TFF	XXXX.X NM XXXX.X NM XXBXX MIN-SEC	If TFF = -59B59, TF perigee is available by keying N32E.
	PRO V06 N62 VI H dot H pad	XXXXX. FPS XXXXX. FPS XXXX.X NM	
	SAFE ORBIT Key V37E OOE		

BOOST

3.1

NORMAL BACKUP

APOLLO-SOYUZ TEST PROJECT (ASTP)
OPERATIONS HANDBOOK

START STEP	PROCEDURE	PANEL	REMARKS
	<p>POSTORBITAL INSERTION CHECK</p> <p>Monitor LV tank pressures (LOX and fuel) from orbit indicator and ADVISIVE set for the following conditions:</p> <p>LOX > 32 psia (fuel > fuel)</p> <p>LOX < 32 psia (fuel < fuel)</p> <p>LOX and fuel tank pressure < 30 psia</p> <p>XXXXXXXXXXXXXXXXXXXXXXXXXXXXXXXXXXXXX</p> <p>If AT, LOX or fuel tank pressures exceeded verify/ accomplish following:</p> <p>SC SECS ARM (2) - close</p> <p>SECS LOGIC (both) - on (up)</p> <p>SECS PYRO ARM (2) - on (up)</p> <p>THC PWR - on (up)</p> <p>RHC (both) - ARMED</p> <p>RHC PWR DIF (both) - MNA/MNB</p> <p>SC CONT - SCS</p> <p>AUTO RCS B/D ROLL (4) - MNA</p> <p>AUTO RCS PITCH (4) - MNA</p> <p>AUTO RCS YAW (4) - MNA</p> <p>THC - CCW (4 sec)</p> <p>MN BUS TIE (2) - on (up)</p> <p>TVC SERVO PWR 1 - AC1/MNA</p> <p>TVC SERVO PWR 2 - AC2/MNB</p>	<p>1</p> <p>6</p> <p>1</p> <p>8</p> <p>5</p> <p>7</p>	<p>Refer to mission rules concerning EIVE fuel and oxidizer tank pressures. Venting after engine cut-off will normally result in LOX tank pressure decrease to ~32 psia and fuel tank pressure decreasing.</p> <p>Provides CSM/LV separation if LV tank pressures exceeded. Control positions verified in the event status checklist or separation preparation performed prior to contingency.</p> <p>Lever lock.</p> <p>Lever lock.</p> <p>CSM/LV separation.</p>

POSTORBITAL INSERTION CHECK

ALCANTARA-10 (U2) TEST PROJECT (ACT1)
OPERATIONS HANDBOOK

START STEP	SEQUENCE	PANEL	REMARKS
	<p> 1. 1 - ATT 1/RATE 2 2. 1 - START 3. 1 - ARMED 4. 1 - NEUTRAL 2 +X 5. 1 - THRUST A - NORM 6. 1 - THRUST ON P1 - push 7. 1 - +X - release 8. 1 - THRUST A - OFF X XX X XX X </p>	1	<p> STAFF position is momentary. Start SPS gimbal motors sequentially at 1-second intervals to avoid power surge. Guarded. CPS ignition. Guarded. </p>
DP	<p> 3.2.1 Status Checklist DC IND sel - FC 3 DC AMPS ind - monitor amps decr after each No. 2 gmb1 mot shutdown </p>	3	Decrease verifies gimbal motor shutdown.
AC	<p> GMBL MOT P2, Y2 - OFF </p>	1	Shut off gimbal motors sequentially to avoid power surge. Shutdown of No. 2 motors first minimizes switching in servo logic.
DP	<p> DC IND sel - FC 1 or 2 DC AMPS ind - monitor amps decr after each No. 1 gmb1 mot shutdown </p>	3	Decrease verifies gimbal motor shutdown.
AC	<p> GMBL MOT P1, Y1 - OFF </p>	1	
DP	<p> cb ELS/CN SM SEP (2) - open </p>	3	
AC	<p> DC IND sel - ATIA </p>	5	
AC	<p> PHC PWP DIP (both) - OFF </p>	1	

STATUS CHECKLIST

3.2.1

NORMAL BACKUP

APOLLO JETTY TEST PROJECT (AJTP)
OPERATIONS HANDBOOK

STEP	SEQUENCE	PANEL	REMARKS
1	<p>1. JETT - OFF 2. LOCKS - OPEN 3. JETT - ON 4. JETT - OFF 5. JETT - ON 6. JETT - OFF 7. JETT - ON 8. JETT - OFF 9. JETT - ON 10. JETT - OFF 11. JETT - ON 12. JETT - OFF 13. JETT - ON 14. JETT - OFF 15. JETT - ON 16. JETT - OFF 17. JETT - ON 18. JETT - OFF 19. JETT - ON 20. JETT - OFF 21. JETT - ON 22. JETT - OFF 23. JETT - ON 24. JETT - OFF 25. JETT - ON 26. JETT - OFF 27. JETT - ON 28. JETT - OFF 29. JETT - ON 30. JETT - OFF 31. JETT - ON 32. JETT - OFF 33. JETT - ON 34. JETT - OFF 35. JETT - ON 36. JETT - OFF 37. JETT - ON 38. JETT - OFF 39. JETT - ON 40. JETT - OFF 41. JETT - ON 42. JETT - OFF 43. JETT - ON 44. JETT - OFF 45. JETT - ON 46. JETT - OFF 47. JETT - ON 48. JETT - OFF 49. JETT - ON 50. JETT - OFF 51. JETT - ON 52. JETT - OFF 53. JETT - ON 54. JETT - OFF 55. JETT - ON 56. JETT - OFF 57. JETT - ON 58. JETT - OFF 59. JETT - ON 60. JETT - OFF 61. JETT - ON 62. JETT - OFF 63. JETT - ON 64. JETT - OFF 65. JETT - ON 66. JETT - OFF 67. JETT - ON 68. JETT - OFF 69. JETT - ON 70. JETT - OFF 71. JETT - ON 72. JETT - OFF 73. JETT - ON 74. JETT - OFF 75. JETT - ON 76. JETT - OFF 77. JETT - ON 78. JETT - OFF 79. JETT - ON 80. JETT - OFF 81. JETT - ON 82. JETT - OFF 83. JETT - ON 84. JETT - OFF 85. JETT - ON 86. JETT - OFF 87. JETT - ON 88. JETT - OFF 89. JETT - ON 90. JETT - OFF 91. JETT - ON 92. JETT - OFF 93. JETT - ON 94. JETT - OFF 95. JETT - ON 96. JETT - OFF 97. JETT - ON 98. JETT - OFF 99. JETT - ON 100. JETT - OFF</p>	1	Lever lock. Lever lock.
2	<p>1. JETT - OFF 2. LOCKS - OPEN 3. JETT - ON 4. JETT - OFF 5. JETT - ON 6. JETT - OFF 7. JETT - ON 8. JETT - OFF 9. JETT - ON 10. JETT - OFF 11. JETT - ON 12. JETT - OFF 13. JETT - ON 14. JETT - OFF 15. JETT - ON 16. JETT - OFF 17. JETT - ON 18. JETT - OFF 19. JETT - ON 20. JETT - OFF 21. JETT - ON 22. JETT - OFF 23. JETT - ON 24. JETT - OFF 25. JETT - ON 26. JETT - OFF 27. JETT - ON 28. JETT - OFF 29. JETT - ON 30. JETT - OFF 31. JETT - ON 32. JETT - OFF 33. JETT - ON 34. JETT - OFF 35. JETT - ON 36. JETT - OFF 37. JETT - ON 38. JETT - OFF 39. JETT - ON 40. JETT - OFF 41. JETT - ON 42. JETT - OFF 43. JETT - ON 44. JETT - OFF 45. JETT - ON 46. JETT - OFF 47. JETT - ON 48. JETT - OFF 49. JETT - ON 50. JETT - OFF 51. JETT - ON 52. JETT - OFF 53. JETT - ON 54. JETT - OFF 55. JETT - ON 56. JETT - OFF 57. JETT - ON 58. JETT - OFF 59. JETT - ON 60. JETT - OFF 61. JETT - ON 62. JETT - OFF 63. JETT - ON 64. JETT - OFF 65. JETT - ON 66. JETT - OFF 67. JETT - ON 68. JETT - OFF 69. JETT - ON 70. JETT - OFF 71. JETT - ON 72. JETT - OFF 73. JETT - ON 74. JETT - OFF 75. JETT - ON 76. JETT - OFF 77. JETT - ON 78. JETT - OFF 79. JETT - ON 80. JETT - OFF 81. JETT - ON 82. JETT - OFF 83. JETT - ON 84. JETT - OFF 85. JETT - ON 86. JETT - OFF 87. JETT - ON 88. JETT - OFF 89. JETT - ON 90. JETT - OFF 91. JETT - ON 92. JETT - OFF 93. JETT - ON 94. JETT - OFF 95. JETT - ON 96. JETT - OFF 97. JETT - ON 98. JETT - OFF 99. JETT - ON 100. JETT - OFF</p>	1 2	Button switch to "OFF" removes holding voltage from open side of TC reactant valves. Guarded.
3	<p>1. JETT - OFF 2. LOCKS - OPEN 3. JETT - ON 4. JETT - OFF 5. JETT - ON 6. JETT - OFF 7. JETT - ON 8. JETT - OFF 9. JETT - ON 10. JETT - OFF 11. JETT - ON 12. JETT - OFF 13. JETT - ON 14. JETT - OFF 15. JETT - ON 16. JETT - OFF 17. JETT - ON 18. JETT - OFF 19. JETT - ON 20. JETT - OFF 21. JETT - ON 22. JETT - OFF 23. JETT - ON 24. JETT - OFF 25. JETT - ON 26. JETT - OFF 27. JETT - ON 28. JETT - OFF 29. JETT - ON 30. JETT - OFF 31. JETT - ON 32. JETT - OFF 33. JETT - ON 34. JETT - OFF 35. JETT - ON 36. JETT - OFF 37. JETT - ON 38. JETT - OFF 39. JETT - ON 40. JETT - OFF 41. JETT - ON 42. JETT - OFF 43. JETT - ON 44. JETT - OFF 45. JETT - ON 46. JETT - OFF 47. JETT - ON 48. JETT - OFF 49. JETT - ON 50. JETT - OFF 51. JETT - ON 52. JETT - OFF 53. JETT - ON 54. JETT - OFF 55. JETT - ON 56. JETT - OFF 57. JETT - ON 58. JETT - OFF 59. JETT - ON 60. JETT - OFF 61. JETT - ON 62. JETT - OFF 63. JETT - ON 64. JETT - OFF 65. JETT - ON 66. JETT - OFF 67. JETT - ON 68. JETT - OFF 69. JETT - ON 70. JETT - OFF 71. JETT - ON 72. JETT - OFF 73. JETT - ON 74. JETT - OFF 75. JETT - ON 76. JETT - OFF 77. JETT - ON 78. JETT - OFF 79. JETT - ON 80. JETT - OFF 81. JETT - ON 82. JETT - OFF 83. JETT - ON 84. JETT - OFF 85. JETT - ON 86. JETT - OFF 87. JETT - ON 88. JETT - OFF 89. JETT - ON 90. JETT - OFF 91. JETT - ON 92. JETT - OFF 93. JETT - ON 94. JETT - OFF 95. JETT - ON 96. JETT - OFF 97. JETT - ON 98. JETT - OFF 99. JETT - ON 100. JETT - OFF</p>	5	PCM heaters.
4	<p>1. JETT - OFF 2. LOCKS - OPEN 3. JETT - ON 4. JETT - OFF 5. JETT - ON 6. JETT - OFF 7. JETT - ON 8. JETT - OFF 9. JETT - ON 10. JETT - OFF 11. JETT - ON 12. JETT - OFF 13. JETT - ON 14. JETT - OFF 15. JETT - ON 16. JETT - OFF 17. JETT - ON 18. JETT - OFF 19. JETT - ON 20. JETT - OFF 21. JETT - ON 22. JETT - OFF 23. JETT - ON 24. JETT - OFF 25. JETT - ON 26. JETT - OFF 27. JETT - ON 28. JETT - OFF 29. JETT - ON 30. JETT - OFF 31. JETT - ON 32. JETT - OFF 33. JETT - ON 34. JETT - OFF 35. JETT - ON 36. JETT - OFF 37. JETT - ON 38. JETT - OFF 39. JETT - ON 40. JETT - OFF 41. JETT - ON 42. JETT - OFF 43. JETT - ON 44. JETT - OFF 45. JETT - ON 46. JETT - OFF 47. JETT - ON 48. JETT - OFF 49. JETT - ON 50. JETT - OFF 51. JETT - ON 52. JETT - OFF 53. JETT - ON 54. JETT - OFF 55. JETT - ON 56. JETT - OFF 57. JETT - ON 58. JETT - OFF 59. JETT - ON 60. JETT - OFF 61. JETT - ON 62. JETT - OFF 63. JETT - ON 64. JETT - OFF 65. JETT - ON 66. JETT - OFF 67. JETT - ON 68. JETT - OFF 69. JETT - ON 70. JETT - OFF 71. JETT - ON 72. JETT - OFF 73. JETT - ON 74. JETT - OFF 75. JETT - ON 76. JETT - OFF 77. JETT - ON 78. JETT - OFF 79. JETT - ON 80. JETT - OFF 81. JETT - ON 82. JETT - OFF 83. JETT - ON 84. JETT - OFF 85. JETT - ON 86. JETT - OFF 87. JETT - ON 88. JETT - OFF 89. JETT - ON 90. JETT - OFF 91. JETT - ON 92. JETT - OFF 93. JETT - ON 94. JETT - OFF 95. JETT - ON 96. JETT - OFF 97. JETT - ON 98. JETT - OFF 99. JETT - ON 100. JETT - OFF</p>	278	<p>Remove & stow cb DOCK RING SEP actuation device cb DOCK RING SEP (2) - open (verify)</p> <p style="text-align: center;"><u>WARNING</u></p> <p>If BPC JETT knot cannot be positioned 180° away from the BPC JETT position before opening side hatch, a pin in the plunger may be sheared possibly allowing press seal to be broken. Cabin repressurization may not be possible due to overboard venting around the BPC plunger.</p>

STATUS CHECKLIST

ACCORDION-BOUNCE TEST PROJECT (ASTP)
OPERATIONS HANDBOOK

START STEP	PROCEDURE	PANEL	REMARKS
3.2.1	<p>1. Jett handle - turn error or error light off 2. Jett handle - verify 3. Jett handle - verify 4. Jett handle - verify 5. Jett handle - verify 6. Jett handle - verify 7. Jett handle - verify 8. Jett handle - verify 9. Jett handle - verify 10. Jett handle - verify 11. Jett handle - verify 12. Jett handle - verify 13. Jett handle - verify 14. Jett handle - verify 15. Jett handle - verify 16. Jett handle - verify 17. Jett handle - verify 18. Jett handle - verify 19. Jett handle - verify 20. Jett handle - verify 21. Jett handle - verify 22. Jett handle - verify 23. Jett handle - verify 24. Jett handle - verify 25. Jett handle - verify 26. Jett handle - verify 27. Jett handle - verify 28. Jett handle - verify 29. Jett handle - verify 30. Jett handle - verify 31. Jett handle - verify 32. Jett handle - verify 33. Jett handle - verify 34. Jett handle - verify 35. Jett handle - verify 36. Jett handle - verify 37. Jett handle - verify 38. Jett handle - verify 39. Jett handle - verify 40. Jett handle - verify 41. Jett handle - verify 42. Jett handle - verify 43. Jett handle - verify 44. Jett handle - verify 45. Jett handle - verify 46. Jett handle - verify 47. Jett handle - verify 48. Jett handle - verify 49. Jett handle - verify 50. Jett handle - verify 51. Jett handle - verify 52. Jett handle - verify 53. Jett handle - verify 54. Jett handle - verify 55. Jett handle - verify 56. Jett handle - verify 57. Jett handle - verify 58. Jett handle - verify 59. Jett handle - verify 60. Jett handle - verify 61. Jett handle - verify 62. Jett handle - verify 63. Jett handle - verify 64. Jett handle - verify 65. Jett handle - verify 66. Jett handle - verify 67. Jett handle - verify 68. Jett handle - verify 69. Jett handle - verify 70. Jett handle - verify 71. Jett handle - verify 72. Jett handle - verify 73. Jett handle - verify 74. Jett handle - verify 75. Jett handle - verify 76. Jett handle - verify 77. Jett handle - verify 78. Jett handle - verify 79. Jett handle - verify 80. Jett handle - verify 81. Jett handle - verify 82. Jett handle - verify 83. Jett handle - verify 84. Jett handle - verify 85. Jett handle - verify 86. Jett handle - verify 87. Jett handle - verify 88. Jett handle - verify 89. Jett handle - verify 90. Jett handle - verify 91. Jett handle - verify 92. Jett handle - verify 93. Jett handle - verify 94. Jett handle - verify 95. Jett handle - verify 96. Jett handle - verify 97. Jett handle - verify 98. Jett handle - verify 99. Jett handle - verify 100. Jett handle - verify</p>	<p>1. Jett handle 2. Jett handle 3. Jett handle 4. Jett handle 5. Jett handle 6. Jett handle 7. Jett handle 8. Jett handle 9. Jett handle 10. Jett handle 11. Jett handle 12. Jett handle 13. Jett handle 14. Jett handle 15. Jett handle 16. Jett handle 17. Jett handle 18. Jett handle 19. Jett handle 20. Jett handle 21. Jett handle 22. Jett handle 23. Jett handle 24. Jett handle 25. Jett handle 26. Jett handle 27. Jett handle 28. Jett handle 29. Jett handle 30. Jett handle 31. Jett handle 32. Jett handle 33. Jett handle 34. Jett handle 35. Jett handle 36. Jett handle 37. Jett handle 38. Jett handle 39. Jett handle 40. Jett handle 41. Jett handle 42. Jett handle 43. Jett handle 44. Jett handle 45. Jett handle 46. Jett handle 47. Jett handle 48. Jett handle 49. Jett handle 50. Jett handle 51. Jett handle 52. Jett handle 53. Jett handle 54. Jett handle 55. Jett handle 56. Jett handle 57. Jett handle 58. Jett handle 59. Jett handle 60. Jett handle 61. Jett handle 62. Jett handle 63. Jett handle 64. Jett handle 65. Jett handle 66. Jett handle 67. Jett handle 68. Jett handle 69. Jett handle 70. Jett handle 71. Jett handle 72. Jett handle 73. Jett handle 74. Jett handle 75. Jett handle 76. Jett handle 77. Jett handle 78. Jett handle 79. Jett handle 80. Jett handle 81. Jett handle 82. Jett handle 83. Jett handle 84. Jett handle 85. Jett handle 86. Jett handle 87. Jett handle 88. Jett handle 89. Jett handle 90. Jett handle 91. Jett handle 92. Jett handle 93. Jett handle 94. Jett handle 95. Jett handle 96. Jett handle 97. Jett handle 98. Jett handle 99. Jett handle 100. Jett handle</p>	<p>Disarms boost cover hatch release mechanism, preventing JETT plunger from actuating during inflight operation of hatch.</p> <p>This data defines landing site and thrusting parameters for a first orbit, deorbit, and entry.</p> <p>Check must be performed as near to orbit injection as possible to prevent additional drift in attitude reference systems.</p>
3.2.2	<p>3.2.2.1 SQT Attitude Reference Comparison Check, 8.4.7</p>		
3.2.3	<p>3.2.3.1 SQT/SXT Dust Cover Jett Procedure <u>WARNING</u></p> <p>Until optics are to be used, the OPT ZERO (int 122), should be kept at ZERO to prevent inadvertent Jett of optics covers.</p>		

3.2.3

SQT/SXT DUST COVER JETT PROCEDURE

NORMAL/BACKUP

REACTOR COOLANT SYSTEM PROJECT (RSCP)
OPERATIONAL HANDBOOK

START STEP	PROCEDURE	PANEL	REMARKS
100	<p>1. Press STOP button on control panel.</p> <p>2. Press STOP button on control panel.</p> <p>3. Press STOP button on control panel.</p> <p>4. Press STOP button on control panel.</p> <p>5. Press STOP button on control panel.</p> <p>6. Press STOP button on control panel.</p> <p>7. Press STOP button on control panel.</p> <p>8. Press STOP button on control panel.</p> <p>9. Press STOP button on control panel.</p> <p>10. Press STOP button on control panel.</p>	<p>100 100</p>	<p>OFF ZERO - OFF enables function of OFF W/D and OFF W/D switches.</p> <p>When running RCP must cover junction box and W/D and W/D. The control panel should be maintained at full time through these junction covers are jettisoned.</p>
101	<p>1. Press STOP button on control panel.</p> <p>2. Press STOP button on control panel.</p> <p>3. Press STOP button on control panel.</p> <p>4. Press STOP button on control panel.</p> <p>5. Press STOP button on control panel.</p> <p>6. Press STOP button on control panel.</p> <p>7. Press STOP button on control panel.</p> <p>8. Press STOP button on control panel.</p> <p>9. Press STOP button on control panel.</p> <p>10. Press STOP button on control panel.</p>	<p>101</p>	<p>Provides rapid post-insertion pressure indicator check of secondary radiator circuit - verification system was not opened during boost phase. This does not verify coolant loop heat rejection capability as defined in 5.4.2, step 7.</p>
102	<p>1. Press STOP button on control panel.</p> <p>2. Press STOP button on control panel.</p> <p>3. Press STOP button on control panel.</p> <p>4. Press STOP button on control panel.</p> <p>5. Press STOP button on control panel.</p> <p>6. Press STOP button on control panel.</p> <p>7. Press STOP button on control panel.</p> <p>8. Press STOP button on control panel.</p> <p>9. Press STOP button on control panel.</p> <p>10. Press STOP button on control panel.</p>	<p>102</p>	<p>Prevents inadvertent opening of post-latching vent valves.</p>

ECS POST-INSERTION CONFIGURATION

APOLLO-SOYUZ TEST PROJECT (ASTP)
OPERATIONS HANDBOOK

STA/T STEP	PROCEDURE	PANEL	REMARKS
DP	PRIM GLY EVAP STM PRESS ind - 0.09-C.14 psia PRIM GLY EVAP OUT TEMP ind - 38°-43°F Initiate rad flow	2	Water-glycol flow through primary loop radiators to commence no sooner than T +20:00 or later than T +55:00. After 2-1/2 minutes of flow, radiator outlet temperature should be less than inlet temperature.
AC	GLY HSVR BYP vlv - OPEN GLY HSVR OUT vlv - CLOSE GLY HSVR IN vlv - CLOSE	326	
DP CP,DP	PRIM ACCUM QTY ind - 30-65% PRIM ACCUM FILL vlv - ON, until 40-55% is reached	2 379,2	Primary accumulator quantity reading must be increased by at least 5% to provide ullage in glycol reservoir for temperature excursions.
DP AC DF	RAD FLOW CONT PWR - PWR PRIM GLY TO RAD - NORM RAD PRIM OUT TEMP ind - below RAD PRIM IN TEMP ind	2 325 2	
AC	XXXXXXXXXXXXXXXXXXXXXXXXXXXXXXXXXXXXX X Outlet temp > than inlet after 5 min PRIM GLY TO RAD - BYP (pull), recheck in 10 min X XXXXXXXXXXXXXXXXXXXXXXXXXXXXXXXXXXXXX X	325	ECS primary loop radiators again isolated. In 10 minutes, flow through radiators is attempted once more by repeating procedure.
CP DP	DRINK H2O SUP vlv - ON (CCW) ECS RAD tb - Gray	304 2	Gray indicates No. 1 flow proportioning valve controlling flow.

ECS POSTINSERTION CONFIGURATION

3.2.4

NORMAL BACKUP

APOLLO-SOYUZ TEST PROJECT (ASTP)
OPERATIONS HANDBOOK

STA/T STEP	PROCEDURE	PANEL	REMARKS
CP	POT H2O HTR - NSA CLY EVAP IN TEMP - AUTO cb H2O/URINE DUMP HTR (2) - close REPRESS PKG vlv - FILL for 10 sec, then OFF	2 5 326	
CP	REPRESS O2 PRESS ind - >865 psia	602	
	<u>3.2.5 Systems Verification and Monitoring</u>		
AC	1 Mount ORDEAL BOX Perform ORDEAL Initialization, 8.4.8	13	
	2 Perform C&WS Oper Check, 5.5.1		
	3 Perform SM RCS Mon Check, 5.2.2		
	4 Perform CM RCS Mon Check, 5.2.3		
CP.	5 Perform EPS Checks, 5.3.1 thru 5.3.4		
DP	6 Perform ECS Mon Check, 5.4.1		
	7 Perform SPS Mon Check, 5.2.1		
DP	8 cb COAS/TUUL LTG MIB - close	226	Provides power for COAS, six tunnel lights, and docking spotlight door initiator.

SYSTEMS VERIFICATION AND MONITORING

APOLLO-SOYUZ TEST PROJECT (ASTP)
OPERATIONS HANDBOOK

STA/T STEP	PROCEDURE	PANEL	REMARKS
3.2.6 Cabin Atmosphere Verification			
DP 1	CAB PRESS ind - 5.6-6.2 psia & decr	2	Cabin pressure will be 5.6-6.2 psia after launch and continuously decrease until cabin pressure regulator activates and controls pressure to 4.7-5.3 psia.
AC 2	DIRECT O2 vlv - close (CW)	7	Direct O2 should remain open for at least 3 hours for O2 purge. O2 flow will be 0.7+0.1 lbs/hr during purge.
DP 3	O2 FLOW ind - 0.2 lb/hr	2	
CP 4	EMER CAB PRESS sel - BOTH	351	
5	SUIT RETURN vlv - open (pull)	380	
ALL 6	Gloves & helmet removed		
CP 7	When CAB PRESS ind <5.3 psia O2 FLOW ind - 1.0 lb/hr O2 FLOW HI lt - on MASTER ALARM pb/lt - on, push	2 1,3,122	After 16-second time delay.
3	60/40 cab purge complete at 8 hrs WASTE STOW VENT vlv - CLOSE O2 FLOW HI lt - out	252 2	

CABIN ATMOSPHERE VERIFICATION

3.2.6

NORMAL/BACKUP

APOLLO-SOYUZ TEST PROJECT (ASTP)
OPERATIONS HANDBOOK

STA/T STEP	PROCEDURE	PANEL	REMARKS												
4.0	DM INTERFACE														
4.1	CSM/SLA SEPARATION, TRANSPOSITION AND DOCKING														
1	<p>The following are req</p> <p>CMC - on, 8.1.3</p> <p>CCAS - installed & calib, 13.1.8</p> <p>CM Docking Sys Probe Extension & Status Check, 5.7.6</p> <p>SCS - on, 8.4.2</p> <p>ISS - on & orient known, 8.1.3 & sec 13</p> <p>UDAP load & activate, 8.2.1</p> <p>R1 - 111XX Moun 46 Disp</p> <p>R2 - X1111</p> <p>SIV3 mnvrs to sep att</p> <p>XXXXXXXXXXXXXXXXXXXXXXXXXXXXX</p> <p>X If LV GUID sw - CMC</p> <p>Do not reload UDAP</p> <p>Mnvr to sep att</p> <p>R ___ ° P ___ ° Y ___ °</p> <p>XXXXXXXXXXXXXXXXXXXXXXXXXXXXX</p> <p>X</p> <p>Key VI6N20E</p> <p>(N20) R ___ ° P ___ ° Y ___ °</p> <p>(N22) R ___ ° P ___ ° Y ___ °</p> <p>Load N22 (docking att)</p> <p>Pnl configuration per 3.2.1</p>		<p>Provides G&N control capability.</p> <p>Provides SCS control capability.</p> <p>Establishes G&N control capability as follows: CSM configuration, 4 quad translation (quads A, B, C, D - on).</p> <p>CSM maneuver should be performed in the following attitude and rate deadbands in either the CMC or SCS control modes to simplify control task during separation.</p> <table border="1" data-bbox="485 1320 837 1779"> <thead> <tr> <th></th> <th>CMC</th> <th>SCS</th> </tr> </thead> <tbody> <tr> <td>ATT DRD</td> <td>+0.5° (R03)</td> <td>+0.2° (MIN)</td> </tr> <tr> <td>RATE DRD</td> <td>+0.2°/sec (fixed)</td> <td>+0.2°/sec (LO)</td> </tr> <tr> <td>RATE CMD (RHC)</td> <td>+0.5°/sec (R03)</td> <td>+0.65°/sec</td> </tr> </tbody> </table> <p>Postorbital insertion status checklist.</p>		CMC	SCS	ATT DRD	+0.5° (R03)	+0.2° (MIN)	RATE DRD	+0.2°/sec (fixed)	+0.2°/sec (LO)	RATE CMD (RHC)	+0.5°/sec (R03)	+0.65°/sec
	CMC	SCS													
ATT DRD	+0.5° (R03)	+0.2° (MIN)													
RATE DRD	+0.2°/sec (fixed)	+0.2°/sec (LO)													
RATE CMD (RHC)	+0.5°/sec (R03)	+0.65°/sec													
4.1			CSM/SLA SEPARATION, TRANSPOSITION AND DOCKING												

NORMAL BACKUP

APOLLO-SOYUZ TEST PROJECT (ASTP)
OPERATIONS HANDBOOK

STA/T STEP	PROCEDURE	PANEL	REMARKS
1	<p>Enl reconfiguration & sep prep Key V60E</p> <p>Key V63E</p> <p>Verify SM RCS activation SM RCS PRPLANT tb (8) - gray</p> <p>Set pnl 1 SCS att controls</p> <p>THC PWR - on (up)</p> <p>RHC PWR DIR (both) - MNA/MNE</p> <p>RHC PWR NORM (both) - AC/DC</p> <p>EMAG MODE (3) - RATE 2</p> <p>SC CONT - SCS</p> <p>DBD/RATE - MIN/LO</p> <p>ATT DBD - MIN</p> <p>RATE - LO</p> <p>CMC MODE - FREE</p> <p>LIM CYCLE - OFF</p> <p>LV IND/CPI sw - SIVB (verify)</p> <p>AUTO RCS (16) - MNA or MNB</p>	2	<p>Nulls FDAI 1 error needles, N17 = N20.</p> <p>Permits display of error between present and astronaut loaded gimbal angles on FDAI 1, N20 and N17.</p>
2	<p>MAN ATT (3) - RATE CMD</p> <p>FDAI SCALE - 5/1</p> <p>TVC SERVO PWR 1 - AC1/MNA</p> <p>Establish sep performance cues</p> <p>Perform EMS ΔV Test & Null Bias check, 7.6.1, & EMS ΔV Setup, 7.6.2, except set ΔV ind at -100 to avoid operation around the 0.0 fps settings</p>	1	<p>Enables direct RCS coils for contingency takeover.</p> <p>Cares the EMAGs and prevents attitude maneuver signals from causing them to hit their stops.</p>
3	<p>Jets enabled on MN bus A & B should be selected so that command will be maintained for the most critical maneuvers in case of either dc bus failure.</p> <p>Establishes proportional manual control with rate damping for SCS backup</p>	8	<p>Jets enabled on MN bus A & B should be selected so that command will be maintained for the most critical maneuvers in case of either dc bus failure.</p> <p>Establishes proportional manual control with rate damping for SCS backup</p>
4	<p>MAN ATT (3) - RATE CMD</p> <p>FDAI SCALE - 5/1</p> <p>TVC SERVO PWR 1 - AC1/MNA</p> <p>Establish sep performance cues</p> <p>Perform EMS ΔV Test & Null Bias check, 7.6.1, & EMS ΔV Setup, 7.6.2, except set ΔV ind at -100 to avoid operation around the 0.0 fps settings</p>	7	<p>Establishes proportional manual control with rate damping for SCS backup</p>

CSM/SLA SEPARATION, TRANSPOSITION AND DOCKING

APOLLO-SOYUZ TEST PROJECT (ASTP)
OPERATIONS HANDBOOK

STA/T STEP	PROCEDURE	PANEL	REMARKS
AC	GDC - align, 8.4.6 Establish displays FDAI SEL - 1/2	7	Enables G&N on FDAI 1, SCS on FDAI 2. Integrates state vector forward. RSET position is momentary.
AC, CP	Key V37E 00E	1	Opening these circuit breakers prevents inadvertent direct ullage via THC CCW switches when SECS LOGIC switches on.
AC	EVNT TMR RSEI - PSET EVNT TMR ind - 00:00 cb PCS LOGIC (2) - open	1	
		8	
3	Enbl sequencer logic		Provides power to sequencer and pyro circuits for separation.
	cb SECS ARM (2) - close After STDN AOS		Lever lock.
	SECS LOGIC (both) - on (up) Report logic arm After GO from STDN		Lever lock.
	SECS PYRO ARM (2) - on (up) Perform final presep functions V66E		Transfer CSM state vector to Soyuz (LM) storage.
CP	Key V37E 47E (thrust monitor)	2	Permits display of velocity change during thrusting on DSKY. Perform =60 seconds prior to separation to minimize effect on PIPA bias.
	FL V16 N83 ΔVX, Y, Z (cont) XXXX.X FPS		
AC	RHC 2 - ARMED		ON position is momentary. Enables RCS latching relay in SECS. This function also accomplished automatically by SECS.
CP	RCS CMD - ON		
AC	SC CONT - CMC	1	

4.1 CSM/SLA SEPARATION, TRANSPPOSITION AND DOCKING

NORMAL BACK UP

APOLLO-SOYUZ TEST PROJECT (ASTP)
OPERATIONS HANDBOOK

STA/T STEP	PROCEDURE	PANEL	REMARKS
L	Separation		
DP	FC REAC VLVS - LATCH	3	
AC	EMS MODE - NORM	1	Perform 30 seconds prior to separation to minimize effective EMS drift.
	CMC MODE - HOLD or AUTO		
	THC - ARMED		
-00:03	THC - +X & hold 3 sec prior to sep		Initiates pre-separation tension.
00:00	CSM/LV SEP pb - push & hold		Guarded.
	Start Evt Tmr		
	LV TK PRESS ind (4) - 0		Indicates physical separation.
	LV ENG 1 lt - out		
	CSM/LV SEP pb - rel		
	XXXXXXXXXXXXXXXXXXXXXXXXXXXXXXXXXXXXX		
	X		
	No sep		
	cb RCS LOGIC (2) - close	8	Activates automatic SECS separation and direct RCS ullage.
	THC - CCM (leave in detent)		
00:00	Evt Tmr rset & counting up (auto)	1	SECS delays separation for 3 seconds. Indicates physical separation.
00:03	RCS direct ullage (auto)		Terminates automatic direct RCS ullage.
	LV TK PRESS ind (4) - 0		
	LV ENG 1 lt - out		
00:07 max	THC - neut		Separation velocity is a function of burn time, ≈2.5 seconds of burn per fps.
	RCS direct ullage terminated (auto)		
	Confirm ΔV = ___ fps		
	XXXXXXXXXXXXXXXXXXXXXXXXXXXXXXXXXXXXX		
	X		
00:04 max	THC - neut		Separation velocity is a function of burn time, ≈2.5 seconds of burn per fps.
	ΔV ≈-10X.X fps		

CSM/SLA SEPARATION, TRANSPOSITION AND DOCKING

APOLLO-SOYUZ TEST PROJECT (ASTP)
OPERATIONS HANDBOOK

STA/T STEP	PROCEDURE	PANEL	REMARKS
5	Postsep pnl configuration		During coast to transposition. Provides correct, safe, formation flight configuration.
CP	Verify SM RCS tb position SM RCS QUAD He tb (4) - gray SM RCS QUAD PRELITE tb (8) - gray SM RCS PSM PRELITE tb (4) - bp PSM He tb - bp PSM MANF ISOL tb - gray SM RCS QUAD SEC FUEL PPESE (4) - OPEN FC PEAC VLVS - HOPF	2	
DP	Transposition	3	
AC	xxxxxx If propulsive venting not inhibited Do <u>TOI</u> perform -X trans at 00:35 xxxxxx		If propulsive venting not inhibited, minimum separation distance at completion of pitch maneuver will be ~65 feet.
CO:35	THC -X to ΔV = -100.3 fps MAN ATT PITCH - ACCEL CMD PHC - pitch up ~2°/sec Visually acq SIVE & null pitch rate	1	Positive pitch at 2°/second followed by a negative pitch command to null rates at a total pitch maneuver of 180°. At completion of pitch maneuver, minimum separation distance will be ~55 feet.
CP	V62E	2	Permits display of error between present and docking attitude on FDAI 1, N20 and N22.

CSM/SLA SEPARATION, TRANSPOSITION AND DOCKING

4.1

NORMAL BACKUP

APOLLO-SOYUZ TEST PROJECT (ASTP)
OPERATIONS HANDBOOK

STA/T STEP	PROCEDURE	PANEL	REMARKS
AC	<p>MAN ATT PITCH - RATE CMD RHC, THC - Null trans errors & rates Key V49E, 8.3.4 Perform auto mnvr to docking att</p> <p>or</p> <p>Perform man mnvr to docking att CMC MODE - FREE RHC - null error needles</p>	1	
7	<p>Set pnl 1 SCS att controls CMC MODE - FREE (verify) BMAG MODE (3) - ATT 1/RATE 2 SC CONT - SCS</p>		
8	<p>Verify control status for docking COAS PWR - on (up) EXT RNDZ LTS - SPOT</p>	15 274	Guarded. Verifies capture latches not locked.
9	<p>PROBE EXTND/REL - RETR (verify) PROBE EXTND/REL tb (2) - gray (verify)</p>	2	Rate established visually. Use COAS and docking target for alignment cues. Contact will be indicated by audio cues, a slight disturbance in motion, and/or COAS observation.
10	<p>Initiate capture latch THC - translate to close at 0.25 to 0.5 fps maintain min lateral velocity RHC - maintain min relative align angles with SIVB At contact, apply +X thrust as req</p>		

CSM/SLA SEPARATION, TRANSPOSITION AND DOCKING

APOLLO-SOYUZ TEST PROJECT (ASTP)
OPERATIONS HANDBOOK

STA/T STEP	PROCEDURE	PANEL	REMARKS
CP AC	PROBE EXTND/REL tb (?) - bp SC CONT - CMC XX X Positive indication of no capture (Backup 1) SC CONT - SCS (verify) THC - (-)X, withdraw to formation flight distance PROBE EXTND/REL - EXTND/REL for 5 sec PROBE EXTND/REL - RETR PROBE EXTND/REL tb - gray (verify) ATTEMPT redocking as before or perform redocking with backup 2 procedure (Backup 2) SC CONT - SCS (verify) THC - (-)X, withdraw to formation flight distance ATTEMPT redocking as before and place PROBE EXTND/REL - EXTND/REL (HOLD) during final phase prior to contact. After contact with +X applied and probe in drogue, place PROBE EXTND/REL - RETP XX X	1	Talkbacks barber pole indicate capture. Only one talkback required for indication. Failure to capture will also be indicated by no noticeable rebound tension load (deceleration) and separation from SIVS. If retraction initiated, it will not occur until capture.
		2	Guarded. EXTND/REL position is momentary. Guarded.

4.1 CSM/SLA SEPARATION, TRANSPOSITION AND DOCKING

NORMAL BACKUP

APOLLO-SOYUZ TEST PROJECT (ASTP)
OPERATIONS HANDBOOK

STA/T STEP	PROCEDURE	PANEL	REMARKS
AC	xxx Probe auxiliary retract method SECS PYRO ARM (2) - SAFE SECS LOGIC (2) - OFF cb SECS ARM (2) - OPEN THC - LOCKED RHC - LOCKED UTIL PWR - OFF (verify) Remove UTIL pwr receptacle cap Remove LDEC access pnl (aft of pnl 276) Remove LDEC receptacle J5 cap (fwd LDEC) Remove aux dump nozzle htr cable from stowage Remove docking probe aux harness cable Connect cables together Connect cable between UTIL pwr receptacle and J5 receptacle of fwd LDEC	 8 15	The probe auxiliary retract method bypasses the normal retract circuit. Lever lock. Lever lock. Cap tethered. E tool. LDEC (Lunar Docking Event Controller). Cap tethered. For stowage, reference NASA-S-74-517. Cable length 108 inches. Cable length 12 inches.

CSM/SLA SEPARATION, TRANSPOSITION AND DOCKING

APOLLO-SOYUZ TEST PROJECT (ASTP)
OPERATIONS HANDBOOK

STA/T STEP	PROCEDURE	PANEL	REMARKS
AC	THC - UNLOCKED RHC - UNLOCKED Repeat docking approach at ≈ 0.10 fps RHC - maintain min relative align angles with SIVB At contact, apply +X until hard dock or 10 sec max UTIL PWR - on (up) while thrusting UTIL PWR - OFF, after hard dock XX	15	Probe retracts. Alignment determined using COAS and docking target. Retraction loads may cause docking ring damage. Loads are minimum at zero misalignment during retraction. Docking with roll angles $> +10^\circ$ may prohibit CM/DM umbilical connection. When capture latch alignment satisfactory. 10-inch retraction stroke should take ≈ 10 seconds. Talkback A will indicate only if docking latches 1, 5, and 9 close. Talkback B will indicate only if latches 3, 7, and 11 close. Audio and tactile cues will also indicate docking latch closure.
11	Initiate retraction & docking latch closure PROBE RETR PRIM - 1 Observe retraction movement between the two vehicles PROBE EXTND/REL tb (2) - gray	2	

CSM/SLA SEPARATION, TRANSPOSITION AND DOCKING

4.1

NORMAL BACKUP

APOLLO-SOYUZ TEST PROJECT (ASTP)
OPERATIONS HANDBOOK

STA/T STEP	PROCEDURE	PANEL	REMARKS
CP	<p>XXXXXXXXXXXXXXXXXXXXXXXXXXXXXXXXXXXXX X PROBE EXTND/REL tb (2) - remain bp after 30 sec & docking latch closure cues (auditory & tac- tile) unsatisfactory PROBE RETR PRIM - 2 If docking still unsuccessful PROBE RETR SEC - 1 X XXXXXXXXXXXXXXXXXXXXXXXXXXXXXXXXXXXXX X</p>	2	
AC	<p>12 Safe docking sys SECS PYRO ARM (2) - SAFE SECS LOGIC (both) - OFF cb SECS ARM (2) - open EDS PWR - OFF cb EDS (all) - open PROBE EXTND/REL - OFF PROBE RETR (2) - OFF cb DOCK PROBE (2) - open</p>	8 7 8 2 8	<p>Lever lock. Lever lock. Guarded.</p>
AC	<p>13 Postdocking pnl configuration RATE - HI ATT DBD - MAX cb RCS LOGIC (2) - open (verify)</p>	1 8	<p>If backup method separation is used (THC - CCW), RCS LOGIC circuit breakers will still be closed so that direct ullage will be activated. In this case it is not desirable to open these circuit breakers until after maneuvering is completed.</p>
AC CP	<p>TVC SERVO PWR (2) - OFF EXT RNDZ LTS - off (ctr)</p>	7 274	

CSM/SLA SEPARATION, TRANSPORTATION AND DOCKING

APOLLO-SOYUZ TEST PROJECT (ASTP)
OPERATIONS HANDBOOK

STA/T STEP	PROCEDURE	PANEL	REMARKS
CP	PRO FL V47 Key V47	2	
AC	COAS PWP - OFF Key V47 EMS MOPL - STBY EMS FUNC - OFF EMAG MOPL (3) - RATE 2 Key V47E Key V47E	15 1	
	4.2 PREPARATION FOR DM EJECTION	2	Checks state vector. Moves Soyuz (LH) state vector into CSM state vector.
ALL CP	1 Configure PGAs, 5.4.6b Retrieve & don helmet protective shield		
	2 Configure couches as req		
DF	3 Configure control pnl cb DM PWP (2) - open (verify) cb DM FURNACE/CRYSTAL GROWTH (3) - open (verify) TUNL LTS - on (up)	274	
	4 Perform docking tunnel operations C:/DM tunnel press equalization & integrity check TUNL VENT vlv - DM/CM AP DM/CM AP ind - (-)4.0 psid (pegged) PRESS EQUAL vlv - OPEN DM/CM AP ind - 0.0 psid	12	
4.2			Fwd hatch

PREPARATION FOR DM EJECTION

NORMAL BACKUP

APOLLO-SOYUZ TEST PROJECT (ASTP)
OPERATIONS HANDBOOK

STA/T STEP	PROCEDURE	PANEL	REMARKS
CP	<p>XXXXXXXXXXXXXXXXXXXXXXXXXXXXX X TUNL VENT vlv - DM PRESS, for ≈15 min. XXXXXXXXXXXXXXXXXXXXXXXXXXXXX X</p>	12	
	<p>PRESS EQUAL VLV - CLOSE Monitor DM/CM ΔP ind for 2 min & verify ΔP stable PRESS EQUAL VLV - OPEN Remove fwd hatch, 5.7.1 Verify docking latches</p>	Fwd hatch 12	A minimum of nine good docking ring latches required for any CSM/DM SPS burns.
	<p>Pull latch handle of each latch to ensure hook is engaged Pwr bungee parallel to +X axis (verify)</p>	Fwd hatch tunl	Latch indicator button (red) may protrude through hole in latch handle if latch is not engaged.
CP	<p>XXXXXXXXXXXXXXXXXXXXXXXXXXXXX X If hook(s) not engaged Attempt to engage latch handle prior to recocking latch If pwr bungee not parallel to +X axis Push on top of bungee fairing to obtain final preload If hook(s) cannot be engaged or pwr bungee parallel to +X axis not attained</p>		

PREPARATION FOR DM EJECTION

APOLLO-SOYUZ TEST PROJECT (ASTP)
OPERATIONS HANDBOOK

NORMAL/BACKUP

STA/T STEP	PROCEDURE	PANEL	REMARKS
CP	<p>Recock latch(es) & man trigger, 5.7.10 steps 2 & 4</p> <p>XXXXXXXXXXXXXXXXXXXXXXXXXXXXXXXXXXXXX</p> <p>Verify probe extend latch engaged - indicator (RED) not visible</p> <p>Depress IN2 bleed button (red) at aft end of probe body & hold for 10 sec</p> <p>Disconnect both docking probe connectors (yellow) and install in probe storage receptacles</p> <p>Connect DM umb conn (4) as follows & per following chart</p> <p>P23 to J23 (orange to orange)</p> <p>P24 to J24 (orange to orange)</p> <p>P27 to J27 (yellow to yellow)</p> <p>P28 to J28 (yellow to yellow)</p> <p>Disengage conn from stowage receptacle in DM tunl</p> <p>Pull umb across docking interface</p> <p>Align index marks</p> <p>Push DM umb conn into receptacle in CM docking ring & rot CW to lock</p> <p>Route DM umb thru slot in back of receptacle assy & close fairing (orange)</p> <p>Repeat according to chart for remaining 3 umb</p> <p>Reinstall fwd hatch, 5.7.2</p>	tunl	<p>Required to bleed probe retract gas system for subsequent operation.</p> <p>One at a time.</p> <p>Fairing must be closed to install hatch.</p>
DP	TUNL LTS - OFF	274	
ALL	5 Reconfigure couches as req		

PREPARATION FOR DM EJECTION

4.2

APOLLO-SOYUZ TEST PROJECT (ASTP)
OPERATIONS HANDBOOK

STA/T STEP	PROCEDURE	PANEL	REMARKS
3	DM EJECTION FROM SLA		
1	The following are req CMC - on, 8.1.3 SCS - on, 8.4.2 ISS - on & orientation known, 8.1.3 & sec 13 RCS DAP load & activated, 8.2.1 R1 - 61102 Noun 46 disp R2 - X1111		
	R1 - XXXXX Noun 47 disp R2 - 00000		N47 R1 = combined CSM + DM weight.
2	Pre-DM ejection Set Evt Tmr 00:00 cb SECS ARM (2) - close After STDN AOS SECS LOGIC (both) - on (up) Report logic arm After GO from STDN SECS PYRO ARM (2) - on (up) STDN verify pyro buses armed	1 8	Lever lock. Lever lock.
3	Perform ejection TVC SERVO PWR 1 - AC1/MNA EMS FUNC - AV SET SLEW AV ind - +100.0 EMS FUNC - AV FMS MODE - NORM cb SIVB/DM SEP (2) - close (verify)	7 1 274	Perform ~30 seconds prior to ejection to minimize EMS drift error.
AC			
DP			

DM EJECTION FROM SLA

APOLLO-SOYUZ TEST PROJECT (ASTP)
OPERATIONS HANDBOOK

STA/T STEP	PROCEDURE	PANEL	REMARKS
	<u>CAUTION</u> cb SIVR/DK SEP (2) are to be closed before operating SIVR/DK SEP switches to on (up) position. If not, SIVR/DK SEP will not occur.	274	
00:00	SIVR/DK SEP - on (up)	2	Guarded. On (up) position is momentary. Spring system will provide a minimum separation velocity of TED fps (assumes four actuators operated).
AC	Start Evnt Trn		
00:05	TFC - X & hold		
00:06	TFC - neut		
00:11	CMC MODE - AUTO	1	Provides a minimum separation velocity of TED fps or TED fps if propulsive venting is not inhibited. The following tables provide parameters for flight planning if the variables (SIVB propulsive vent, time of RCS burn, etc.) are changed for specific missions. (See figure 4-1.)
	4. Postejection SECS PYPO ARM (2) - SAFE SECS LOGIC (both) - OFF cb SECS AP* (2) - open cb SIVB/DK SEP (2) - open LV IND/GPI sw - GPI CMC MODE - FREE VAL ATT (3) - MID: IMP SC CONT - SCS Reload DAP T46, R1 = 61111	0 274 1 2	Lever lock. Lever lock. When clear of SIVB.

DN: EJECTION FROM SLA

L.3

NORMAL BACKUP

APOLLO-SOYUZ TEST PROJECT (ASTP)
OPERATIONS HANDBOOK

3 Sec CSM RCS Burn (400 Lb -X Translation)				
Configuration	SIVB Propulsive Vent Force (lbs)	Time to Translate 15 Ft (seconds)		SIVB and CSM Recontact Time (No Evasive Mnvf)
		RCS Burn at 5.0 to 8.0 Sec After Sep	RCS Burn at 8.0 to 11.0 Sec After Sep	
DM Ejection In Earth Parking Orbit	TBD	TBD	TBD	TBD
No CSM RCS -X Translation				
Configuration	SIVB Propulsive Vent Force (lbs)	Time to Translate 15 Ft (secs)		SIVB and CSM Recontact Time (No Evasive Mnvf)
		No RCS Burn		
DM Ejection In Earth Parking Orbit	TBD	TBD		TBD

Figure 4-1. SIVB/CSM Separation: Parameters

DM EJECTION FROM SLA

APOLLO-SOYUZ TEST PROJECT (ASTP)
OPERATIONS HANDBOOK

STA/T STEP	PROCEDURE	PANEL	REMARKS
AC	EMS MODE - STBY EMS FUNC - OFF THC PWR - OFF RHC PWR DIR (both) - OFF RHC, THC - LOCKED TVC SERVO PWR (2) - OFF 5 Verify DM passive mode	1 7	Docking mechanism was configured to passive mode during prelaunch. This check verified passive mode prior to precocking operations and verifies integrity of umbilical connections. Convention for passive mode configuration dictates that structural latches are open as well as docking mechanism being in passive mode. Refer to Figure 10-1 for docking system status light logic.
DP	System A cb DS A IND LOGIC MVA - close cb DS A IND PWR AC1 - close cb DM POWER (2) - close	274	DM wall heaters, fan, lights and instrumentation.
CF	STRUCT LATCH OPEN lt - on PASSIVE lt - on	2	Structure latches should be fully open. PASSIVE lt on (passive mode) requires BACKUP (passive) Hooks at RESET (closed), Body Latches closed, and Guide Ring fully retracted.
DP	cb DS A IND LOGIC MVA - open cb DS A IND PWR AC1 - open System B cb DS B IND LOGIC MNB - close cb DS B IND PWR AC2 - close	274	Conditions same as for System A.

DM EJECTION FROM SLA

4.3

NORMAL BACKUP

APOLLO-SOYUZ TEST PROJECT (ASTP)
OPERATIONS HANDBOOK

STA/T STEP	PROCEDURE	PANEL	REMARKS
CP	<p>If still no lt Exercise System B STRUCT LATCH B - CLOSE STRUCT LATCH CLOSE lt - on STRUCT LATCH B - OPEN STRUCT LATCH CLOSE lt - out STRUCT LATCH OPEN lt - on STRUCT LATCH B - off (ctr) If still no lt</p> <p style="text-align: center;"><u>CAUTION</u></p> <p>STRUCT LATCH - CLOSE must be oper by sys A or B only (single mtr). Stalled gear box load using two mtrs could exceed sys cable breaking strength.</p> <p>Exercise both sys (A & B) simultaneously</p> <p>No PASSIVE lt Perform dock sys passive test (sys A & B), 18.4.7</p> <p>Remove Fwd hatch, 5.7.1 (stow) Remove docking probe & drogue, 5.7.4 & 5.7.7 (stow)</p>	<p>?</p>	<p>System B only. Guarded. Guarded.</p> <p>Gear box loads not excessive when opening structural latches.</p> <p>This operation may necessitate access to DM earlier than planned. This test helps isolate cause of passive light failure before actually exercising backup passive system.</p>

DM EJECTION FROM SLA

NORMAL BACKUP

APOLLO-SOYUZ TEST PROJECT (ASTP)
OPERATIONS HANDBOOK

STA/T STEP	PROCEDURE	PANEL	REMARKS
CP	Perform Lock Rod Press Inter ck, 16.3.1 Perform DM Press, 16.3.2 (steps 1 thru 3) LIGHTING 2 - ON BACKUP PASSIVE (2) - RELEASE BACKUP PASSIVE (2) - RESET BACKUP PASSIVE (2) - off (ctr) PASSIVE lt still not on	215 2	Located in DM. Guarded.
	<p style="text-align: center;"><u>CAUTION</u></p> GUIDE RING - EXTD/RETR must be oper on sys A cr B only (single mtr). Dynamic forces using two mtrs could create loads in struct beyond design limit.		System A only.
	GUIDE RING (A) - EXTD GUIDE RING EXTEND lt - on GUIDE RING (A) - RETR GUIDE RING EXTEND lt - out GUIDE RING (A) - off (ctr) PASSIVE lt still not on GUIDE RING B - EXTD GUIDE RING EXTEND lt - on GUIDE RING B - RETR GUIDE RING EXTEND lt - out GUIDE RING B - off (ctr)		System B only.

DM EJECTION FROM SLA

APOLLO-SOYUZ TEST PROJECT (ASTP)
OPERATIONS HANDBOOK

STA/T STEP	PROCEDURE	PANEL	REMARKS
DP	<p>If still no lt, bypass GUIDE RING limit sw's, or go to malf TBD</p> <p>LIGHTING 2 - START Remove CM O2 hoses from DM (stow in CM)</p> <p>Close DM hatch 2, 18.6.1 (step 3)</p> <p>Install fwd hatch, 5.7.2 cb DS IND LOGIC (2) - open cb DS IND PWR (2) - open cb DS CONTROL BAT (2) - open cb DS MOTORS AC1 (3) - open cb DS MOTORS AC2 (3) - open</p> <p>Xxxx xxx X</p> <p>Guide ring limit sw bypass</p> <p>If GUIDE RING sw will not operate guide ring on sys A or B</p> <p style="text-align: center;"><u>CAUTION</u></p> <p>AC motor limit sw's bypassed. To prevent possible ac motor damage, do not exceed _____ seconds with GUIDE RING sw at EXTD or PETP position.</p>	<p>815</p> <p>274</p>	<p>Timeline may determine that DM should not be closed out.</p> <p>Bypass switches located in DM. Opening of hatches 1 and 2 and entry into DM earlier than planned may be required.</p>

DM EJECTION FROM SLA

4.2

NORMAL BACKUP

APOLLO-SOYUZ TEST PROJECT (ASTT)
OPERATIONS HANDBOOK

STA/T STEP	PROCEDURE	PANEL	REMARKS
DP	<p>Remove Fwd hatch, 5.7.1 (stow) Remove docking probe & drogue, 5.7.4 & 5.7.7 (stow) Perform Dock Mod Press Integ ck, 18.3.1 Perform DM Press, 18.3.2 (steps 1 thru 3)</p>	<p>815 862 274</p>	<p>Located in DM. Guarded. Located in DM.</p>
CP	<p><u>CAUTION</u></p> <p>GUIDE RING - EXTD/RETR must be oper on sys A or B only (single mtr). Dynamic forces using two mtrs could create loads in struct beyond design limit.</p> <p>To Extend</p> <p>GUIDE RING A(B) - EXTD PASSIVE lt - out GUIDE RING EXTEND lt - on STRUCT LATCH OPEN lt - on GUIDE RING A(B) - off (ctr)</p>	<p>2</p>	

DM EJECTION FROM SLA

APOLLO-SOYUZ TEST PROJECT (ASTP)
OPERATIONS HANDBOOK

STA/T STEP	PROCEDURE	PANEL	REMARKS
DP	To Retract	862	Guarded.
CP	GUIDE RING RETR LIMIT SW - BYPASS GUIDE RING A(B) - RETR GUIDE RING EXTEND It - out STRUCT LATCH OPEN It - on When full retract PASSIVE It - on	2	
DP	GUIDE RING A(B) - off (ctr) GUIDE RING LIMIT SW (2) - NORMAL	862	Guarded.
	LIGHTING 2 - START Remove CM O2 hoses from DM (stow in C')	815	Timeline may determine that DM should not be closed out.
	Close DM hatch 2, 18.6.1 (step 3)	274	
	Install fwd hatch, 5.7.2 cb DS IND LOGIC (2) - open cb DS IND PWR (2) - open cb DS CONTROL BAF (2) - open cb DS MOTORS AC1 (3) - open cb DS MOTORS AC2 (3) - open		
	XXX		
4.4	DM JETTISON AND SEPARATION		
1	Key V40E, 8.3.4 Perform auto mnvr to jett att		
or	Perform SCS att mnvr to jett att, 8.4.5		R62.

DM JETTISON AND SEPARATION

4.4

NORMAL/BACKUP

APOLLO-SOYUZ TEST PROJECT (ASTP)
OPERATIONS HANDBOOK

STA/T STEP	PROCEDURE	PANEL	REMARKS
2	DM Jett Config, 18.1.1.4		
3	Perform fwd hatch seal integrity check, 5.7.3		
4	Perform DM jett pref cb DM PWP (2) - open (verify) cb DM FURNACE/CRYSTAL GROWTH (3) - open (verify) cb SICS API (2) - close After STD: AOS SICS LOGIC (both) - on (up) Report logic arm After GC from STD: SICS PYRO API (2) - on (up) At jett att FLAG MODN (3) - ATT 1/RATE 2 SC COME - SCS	274 8	Lever lock. Lever lock.
CP	RCS DAP - load & activate, 8.2.1 P1-11102 146 display P2-X1111	1	
	Key V37E 47E (thrust monitor)	2	P47 should be called just prior to DM jettison to keep IMU compensation and average G computation errors at a minimum.
5	DM Jett cb DOCK RING SEP (2) - close DOCK RING SEP (both) - on (up)	276 2	Guarded and momentary. Provides jettison of docking ring, with probe and DM attached, from CS. Separation velocity of 100 ft/sec will be obtained with the use of the docking ring pyrotechnic separation device only (CM/DM tunnel depressurized). If four quads RCS firing is used to augment AV, 100 pounds of propellant are used for every second of firing. Any pressure in CM/DM tunnel at time of separation will impart an additional AV up to a maximum of 100 ft/sec.

DM JETTISON AND SEPARATION

APOLLO-SOYUZ TEST PROJECT (ASTP)
OPERATIONS HANDBOOK

STA/T STEP	PROCEDURE	PANEL	REMARKS
6 AC	Postjett pnl reconfiguration SECS PYRO ARM (2) - SAFE SECS LOGIC (both) - CPF cb SECS ARM (2) - open	8	Lever lock. Lever lock.
7	Separation Perform SCS att mnvr to sep att, 8.4.5		
or	Perform auto mnvr to sep att, 8.3.4 Monitor G&N thrusting, 8.1.6 EMS MODE - NORM THC - +Z (2 jet) for 1.0 fps ΔV (5 sec min after pyrc sep)	1	
4.5	PRE-DOCKING DM CHECKOUT		
1	Tunnel 1 Press Integ ck & Equalization TUNL VENT - DM/CM ΔP (verify) DM/CM ΔP ind - \leq (+) 1 psid (verify)	12	
	xx x If ΔP > (-1) psid (tunl leaked), or if ΔP > (+1) psid (DM leaked into tunl) PRESS EQUAL vlv - OPEN (until Fwd Hatch DM/CM ΔP ind = 0 psid) PRESS EQUAL vlv - close DM/CM ΔP ind - monitor (2 min) 12 for stability if not stable Report to STDN		
	xx x		

NORMAL BACKUP

PRE-DOCKING DM CHECKOUT

4.5

APOLLO-SOYUZ TEST PROJECT (ASTP)
OPERATIONS HANDBOOK

STA/T STEP	PROCEDURE	PANEL	REMARKS
	PRESS EQUAL vlv - OPEN (CCW)/lock	Fwd Hatch	
2	Remove Stow Fwd Hatch/Probe/Drogue Remove Fwd Hatch, 5.7.1 (stow) Remove Probe, 5.7.6 (stow) Remove Drogue, 5.7.7 (stow) TUNL PRESS RELIEF vlv - capped		
3	Perform DM Press Integ ck, 18.3.1		
4	Perform DM Press, 18.3.2		
5	Perform C/W ck, 18.4.2		
6	Config Telecom, 18.5		
7	Perform following HHAG - Unstow & mount in HIGH PRESS RELIEF vlv recess Initiate CM DSE TAPE RCDR - RCD, FWD, CMD RESET Check DM systems (voice rcd ind's) N2 TANK QTY (both) - >71% O2 TANK QTY (both) - >80% CABIN PRESS ind - 243-274 mmHg Verify HHAG calib with pnl ind CABIN TEMP ind - 13-27°C O2 PART PRESS ind (2) - ≥165 mmHg CO2 PART PRESS ind - <7.6 mmHg	821 3 815	

PRE-DOCKING DM CHECKOUT

APOLLO-SOYUZ TEST PROJECT (ASTP)
OPERATIONS HANDBOOK

STA/T STEP	PROCEDURE	PANEL	REMARKS
CP/ DP	8 Transfer equip 9 Perform TV Install and ckout, 18.5.2 10 Perform Furnace (NA-010) prep, 17.9 4.6 CSM UNDOCKING FROM DM		Equipment to be transferred from DM into CM. Provides procedure for CSM/DM separation in lieu of DM Jettison.
DP	1 Verify CSM/DM pwr interface deactivated UVA drag-thru cable removed, 17.6.7 cb DM FURNACE/CRYSTAL GROWTH (3) - open cb DM PWR (2) - open cb DS A (6) - open cb DS B (6) - open cb DOCK PROBE (2) - open	274 8	
ALL	2 All crewmen transfer to CSM		
DP	3 Perform prep for CSM/DM sep TUML LTS - on (up) Disconnect & stow DM umb conn (4) Install docking drogue & probe, 5.7.8 & 5.7.5 Preload probe & disengage docking latches, 5.7.9 & 5.7.10 Perform fwd hatch seal integrity ck, 5.7.3 TUML LTS - OFF (verify)	274	

CSM UNDOCKING FROM DM

4.6

NORMAL/BACKUP

APOLLO-SOYUZ TEST PROJECT (ASTP)
OPERATIONS HANDBOOK

STA/T STEP	PROCEDURE	PANEL	REMARKS
AC	<p>1. Perform sys prep SCS - on, 5.4.0 TIME - load & activate, 6.2.1 cb A/C POLL, B/D ROLL, P, Y (8) - close (verify) Select desired displays, 7.2 Select Att control, 7.1 MAN ATT (3) - PAUL CMD DEM/RATE - MIN/HI ATT DED - MIN RATE - HI EHC PWR - on (up) PHC PWR POPN (both) - AC/DC RHC PWR DIP (both) - MIN/MAX AUTO RCS (16) - MIN/MAX SC cont - CMC/AUTO SC CONT - CMC CMC MODE - AUTO R/RAG MODE (3) - RATE 2 AV Setup, 7.6.2 Set AV ind +100.0 fps cb DOCK PROFN (2) - close PROF INTD/RETR - RETR PROF EXTD/RETR (2) - bp (verify) PROF EXTD/RETR - OFF SPOT LIGHT - ON</p>	8 1	
CF		8 2	<p>Guarded. Verifies redundant probe retract capability. Guarded.</p>
FD	<p>5. Perform fnl prep nal oper Set Avnt errs VVO STA PWR - DOWN VVO STA SWAPP - START (on signal from AC) EHC MODE - POPN</p>	1	<p>Timer will be set up to read 00:00 at separation. STAFF position is momentary. Timer started by CP.</p>

CSH UNDOCKING FROM DE

APOLLO-SOYUZ TEST PROJECT (ASTP)
OPERATIONS HANDBOOK

STA/T STEP	PROCEDURE	PANEL	REMARKS
6 CF	<p>SM: RCS thrusting prep SM: RCS QUAD PRI' PRELMT (4) - OPEN SM: RCS QUAD PRI' PRELMT tb (4) - gray SM: RCS QUAD SEC PRELMT tb (4) - gray SM: RCS PSM PRELMT (4) - CLOSE SM: RCS PSI' PRELMT tb (4) - bp SM: RCS PSM He - CLOSE PSI: He tb - bp SM: RCS PSM MANF ISOL - CLOSE PSM: MANF ISOL tb - bp RCS: IND sel - S. D (verify) ECS: IND sw - TK PRFSS/QTY (verify)</p>	2	
7 00:00	<p>Undocking/Separation PROBE EXTND/REL - EXTND/REL & hold for DM sep +5 sec PROBE EXTND/REL tb (2) - gray to bp to gray Monitor DM sep SPOT LIGHT - OFF</p>		<p>AC will count down to separation time. Guarded. EXTND/REL position is momentary. Probe extended by a compression spring and attenuator airhead forces. Barber pole indicates power to talkback through probe circuitry. Return to gray indicates full extension of probe. AC will monitor DM separation.</p>

CSM UNDOCKING FROM DM

4.6

NORMAL/BACKUP

5.C SYSTEMS MANAGEMENT

Systems management is a compilation of data and procedures that are common to more than one mission phase. The procedures involve system monitoring, periodic checks, and unique functions of the following systems only: SPS, RCS, EPS, ECS, C&WS, T/C and Mechanical. Systems integrated procedures for prelaunch through postlanding phases will repeatedly reference material contained in systems management.

5.1 GENERAL DATA

This paragraph contains information of a general nature that closely relates with Systems Management procedures.

5.1.1 Systems Test Indicator Readouts

A SYS TEST indicator and two selector switches (panel 101) provide the crew with the capability of monitoring some systems measurements telemetered to STDW. A chart (figure 5-1) for converting the SYS TEST indicator readings to measurement parameters is included in this paragraph. Measurements consist of the following:

- Fuel cells 1, 2, and 3 regulated N2, O2, and F2 pressures
- O2 tank 1 and 2 heater temperatures
- Fuel cells 1, 2, and 3 radiator outlet temperatures
- D4 O2 tank 1 and 2 quantity
- D4 N2 tank 1 and 2 quantity
- D4 O2 partial pressure
- D4 cabin press
- S1 RCS reserve [propellant storage module (PS4 1)] fuel tank temperatures
- UV exp pointing error
- Battery compartment manifold pressure
- Battery relay bus voltage
- SPS engine valve body oxidizer feed line, SPE fuel check valve temperatures
- C4/RCS engine jet oxidizer valve temperature

The systems test indicator conversion chart (figure 5-1) lists positions of the SYS TEST switches (2), and pertinent data available for each indicator readout.

SYSTEMS TEST INDICATOR READOUTS

NORMAL/BACKUP

APOLLO-SOYUZ TEST PROJECT (ASTP)
OPERATIONS HANDBOOK

SYS TEST Ind		System			Nominal Range	
SYS TEST Sel Sw (2)	Position	Function	Measurement No.	Sensor Range	System	Display (volts)
1A	FC 1 N2 PRESS		SC 2060 P	Zero/75 psia	50 - 58 psia	3.3 - 3.9
2A	FC 1 O2 PRESS		SC 2066 P	Zero/75 psia	58 - 69 psia	3.9 - 4.6
3A	FC 1 H2 PRESS		SC 2069 P	Zero/75 psia	57 - 67 psia	3.8 - 4.5
4A	FC 1 RAD OUT TEMP		SC 2087 T	-50/+300°F	-10 - +90°F	0.6 - 2.0
5A	FC 3 N2 PRESS		SC 2062 P	Zero/75 psia	50 - 58 psia	3.3 - 3.9
6A	FC 3 O2 PRESS		SC 2068 P	Zero/75 psia	58 - 69 psia	3.9 - 4.6
7A	FC 3 H2 PRESS		SC 2071 P	Zero/75 psia	57 - 67 psia	3.8 - 4.5
8A	FC 3 RAD OUT TEMP		SC 2089 T	-50/+300°F	-10 - +90°F	0.6 - 2.0
9A	FC 2 N2 PRESS		SC 2061 P	Zero/75 psia	50 - 58 psia	3.3 - 3.9
10A	FC 2 O2 PRESS		SC 2067 P	Zero/75 psia	58 - 69 psia	3.9 - 4.6
11A	FC 2 H2 PRESS		SC 2070 P	Zero/75 psia	57 - 67 psia	3.8 - 4.5
1B	FC 2 RAD OUT TEMP		SC 2088 T	-50/+300°F	-10 - +90°F	0.6 - 2.0
2B	BAT COMPT PRESS		CC 0188 P	Zero/20 psia	< 9 psia	< 2.3
3E	BAT RELAY BUS VOLT		CC 0232 V	Zero/45 vdc	30.5 - 37.0 vdc	3.4 - 4.1
4B	CM RCS ENG 12 VLV TEMP		CR 9001 T	-50/+250°F	> 40°F	> 1.5
5B	CM RCS ENG 14 VLV TEMP		CR 9002 T	-50/+250°F	> 40°F	> 1.5
6B	CM RCS ENG 16 VLV TEMP		CR 9003 T	-50/+250°F	> 40°F	> 1.5
7B	CM RCS ENG 21 VLV TEMP		CR 9101 T	-50/+250°F	> 40°F	> 1.5
8B	CM RCS ENG 23 VLV TEMP		CR 9102 T	-50/+250°F	> 40°F	> 1.5
9B	CM RCS ENG 25 VLV TEMP		CR 9103 T	-50/+250°F	> 40°F	> 1.5

Figure 5-1. Systems Test Indicator Conversion Chart (Sheet 1 of 4)

SYSTEMS TEST INDICATOR READOUTS

APOLLO-SOYUZ TEST PROJECT (ASTP)
OPERATIONS HANDBOOK

SYS TEST Ind		System				Nominal Range	
SYS TEST Sel Sw (2)	Position	Function	Measurement No.	Sensor Range	System	Display (volts)	
10B	SM RCS PSM 1 FUEL TK TEMP	SR 9809 T	0/+150°F	+30 - 105°F	1.0 - 3.5		
11B	N/A	N/A	N/A	N/A	N/A		
1C	SM RCS A PRIM FUEL TK TEMP	SR 5073 T	0/+150°F	+30 - +110°F	1.0 - 3.7		
2C	SM RCS B PRIM FUEL TK TEMP	SR 5075 T	0/+150°F	+30 - +110°F	1.0 - 3.7		
3C	SM RCS C PRIM FUEL TK TEMP	SR 5075 T	0/+150°F	+30 - +110°F	1.0 - 3.7		
4C	SM RCS D PRIM FUEL TK TEMP	SR 5076 T	0/+150°F	+30 - +110°F	1.0 - 3.7		
5C	SPS ENG VLV BODY FUEL TEMP	SP 9020 T	0/+150°F	+40 - +150°F	1.3 - 5.0		
6C	SPS OXID FEED LINE TEMP	SP 9016 T	0/+150°F	+40 - +110°F	1.3 - 3.7		
7C	SPS FUEL CHK VLV TEMP	SP 9018 T	0/+150°F	+40 - +110°F	1.3 - 3.7		
8C	SPS OXID TK OUTBD TEMP	SP 9014 T	0/+150°F	+40 - +110°F	1.3 - 3.7		
9C	N/A	N/A	N/A	N/A	N/A		
10C	CRYO O2 TK1 HTR TEMP	SC 0070 T	-300/+600°F	<350°F	>3.6		
11C	CRYO O2 TK2 HTR TEMP	SC 0071 T	-300/+600°F	<350°F	>3.6		
1D	DM O2 PPA	DF 9615 P	0 - 500 mm Hg	<150 mm Hg	>1.5		
1E	DM O2 PPB	DF 9616 P	0 - 500 mm Hg	<150 mm Hg	>1.5		
1F	DM O2 TK 1 QTY	DF 9632 Q	0 - 100%	0 - 100%	0.0 - 5.0		
1G	DM O2 TK 2 QTY	DF 9637 Q	0 - 100%	0 - 100%	0.0 - 5.0		
1H	DM N2 TK 1 QTY	DF 9652 Q	0 - 100%	0 - 100%	0.0 - 5.0		
1J	DM N2 TK 2 QTY	DF 9657 Q	0 - 100%	0 - 100%	0.0 - 5.0		
1K	DM CABIN PRESS	DF 9605 P	0 - 880 mm Hg	250 - 550 mm Hg	0.9 - 3.1		
1L	UV EXP POINTING ERROR	DL 9666 H	-1 5°/+1.5°	-0.3/+0.3	2.0 - 3.0		
2D thru 1L	N/A	N/A	N/A	N/A	N/A		

Figure 5-1. Systems Test Indicator Conversion Chart (Sheet of 4)

5.1.1

SYSTEMS TEST INDICATOR READOUTS

NORMAL/BACKUP

APOLLO-SOYUZ TEST PROJECT (ASTP)
OPERATIONS HANDBOOK

SYS TEST Indicator Display	Fer Press. (psia)		EPS Rad Cut Temp (°F)	Bat Compt Manf (psia)	Bat Rly Bus (vdc)	SM RCS PMK Fuel Tk (°F)	SM RCS Prim Fuel Tk (°F)	CM RCS Eng Vlv (°F)	SPS Eng Vlv Body (°F)	SPS Oxid- Feed Line, Fuel Ck Vlv, Oxid Tk Uttd (°F)	O2 Lk Err Temp (°F)
	02	02									
0.0	0	0	-50	0.00	0.0	0.0	0.0	-50	0.0	0.0	-300
0.2	3	3	-36	0.80	1.8	6.0	6.0	-38	6.0	6.0	-264
0.4	6	6	-22	1.60	3.6	12.0	12.0	-26	12.0	12.0	-228
0.6	9	9	-6	2.40	5.4	18.0	18.0	-14	18.0	18.0	-192
0.8	12	12	+6	3.20	7.2	24.0	24.0	-02	24.0	24.0	-156
1.0	15	15	+20	4.00	9.0	30.0	30.0	+10	30.0	30.0	-120
1.2	18	18	+34	4.80	10.8	36.0	36.0	+22	36.0	36.0	-84
1.4	21	21	+48	5.60	12.6	42.0	42.0	+34	42.0	42.0	-48
1.6	24	24	+62	6.40	14.4	48.0	48.0	+46	48.0	48.0	-12
1.8	27	27	+76	7.20	16.2	54.0	54.0	+58	54.0	54.0	+24
2.0	30	30	+90	8.00	18.0	60.0	60.0	+70	60.0	60.0	+60
2.2	33	33	+104	8.80	19.8	66.0	66.0	+82	66.0	66.0	+96
2.4	36	36	+118	9.60	21.6	72.0	72.0	+94	72.0	72.0	+132
2.6	39	39	+132	10.40	23.4	78.0	78.0	+106	78.0	78.0	+168
2.8	42	42	+146	11.20	25.2	84.0	84.0	+118	84.0	84.0	+204
3.0	45	45	+160	12.00	27.0	90.0	90.0	+130	90.0	90.0	+240
3.2	48	48	+174	12.80	28.8	96.0	96.0	+142	96.0	96.0	+276
3.4	51	51	+188	13.60	30.6	102.0	102.0	+154	102.0	102.0	+312
3.6	54	54	+202	14.40	32.4	108.0	108.0	+166	108.0	108.0	+348
3.8	57	57	+216	15.20	34.2	114.0	114.0	+178	114.0	114.0	+384
4.0	60	60	+230	16.00	36.0	120.0	120.0	+190	120.0	120.0	+420
4.2	63	63	+244	16.80	37.8	126.0	126.0	+202	126.0	126.0	+456
4.4	66	66	+258	17.60	39.6	132.0	132.0	+212	132.0	132.0	+492
4.6	69	69	+272	18.40	41.4	138.0	138.0	+226	138.0	138.0	+528
4.8	72	72	+286	19.20	43.2	144.0	144.0	+238	144.0	144.0	+564
5.0	75	75	+300	20.00	45.0	150.0	150.0	+250	150.0	150.0	+600

Bracketed values indicate normal values.

Figure 5-1. Systems Test Indicator Conversion Chart (Sheet 3 of 4)

SYSTEMS TEST INDICATOR READOUTS

APOLLO-SOYUZ TEST PROJECT (ASTP)
OPERATIONS HANDBOOK

SYS TEST Ind Display	DM O2 Tk 1/2 Qty (%)	DM N2 Tk 1/2 Qty (%)	DM O2 PP A (mm Hg)	DM O2 PP B (mm Hg)	DM Cabin Press. (mm Hg)	UV Exp Pointing (Fly to ind-degrees)
0.0	0	0	0	0	0.0	-1.50
0.2	4	4	20	20	35.2	-1.38
0.4	8	8	40	40	70.4	-1.26
0.6	12	12	60	60	105.6	-1.14
0.8	16	16	80	80	140.8	-1.02
1.0	20	20	100	100	176.0	-0.90
1.2	24	24	120	120	211.2	-0.78
1.4	28	28	140	140	246.4	-0.66
1.6	32	32	160	160	281.6	-0.54
1.8	36	36	180	180	316.8	-0.42
2.0	40	40	200	200	352.0	-0.30
2.2	44	44	220	220	387.2	-0.18
2.4	48	48	240	240	422.4	-0.06
2.6	52	52	260	260	457.6	+0.06
2.8	56	56	280	280	492.8	+0.18
3.0	60	60	300	300	528.0	+0.30
3.2	64	64	320	320	563.2	+0.42
3.4	68	68	340	340	598.4	+0.54
3.6	72	72	360	360	633.6	+0.66
3.8	76	76	380	380	668.8	+0.78
4.0	80	80	400	400	704.0	+0.90
4.2	84	84	420	420	739.2	+1.02
4.4	88	88	440	440	774.4	+1.14
4.6	92	92	460	460	809.6	+1.26
4.8	96	96	480	480	844.8	+1.38
5.0	100	100	500	500	880.0	+1.50

Figure 5-1. System Test Indicator Conversion Chart (Sheet 4 of 4)

SYSTEM TEST INDICATOR READOUTS

5.1.1

NORMAL/BACKUP

APOLLO-SOYUZ TEST PROJECT (ASTP)
OPERATIONS HANDBOOK

5.1.2 Limited Use Circuit Breakers				
The following list defines circuit breakers which may be open during major portions of flight time. Primary considerations are to maintain maximum crew safety, reduce consumable usage, increase equipment reliability, and furnish redundant capabilities.				
Circuit Breakers	Panel Location	When Opened	When Closed	Remarks
02 VAC ION PUMPS (2)	5	Prelaunch	When required	Closure will be by STDN notification when required.
FLT/PL BUS BAT A, B & C (3)	5	Prelaunch	Prior to splashdown	Opened to isolate bat A & B and bat C from flight and postlanding bus.
EXP PWR A EXP BUS	5	Prelaunch	Prior to SAM experiment (MAOC7)	No further use after experiment.
EXP PWR B & C EXP BUS (2)	5	Prelaunch	When required	No requirements are defined for use of these circuit breakers at the present time.
IVA PWR (2)	5	Prelaunch	When required	No requirements at the present time.
H2O/URINE DUMP HTR MNB	5	Prelaunch	When required	Closed when MNA circuit fails.
CM RCS HTRS (both)	8	Prelaunch	Prior to undocking, deorbit and entry if heating required	Opened to ensure against inadvertent activation. Heating probably will be required.

LIMITED USE CIRCUIT BREAKERS

APOLLO-SOYUZ TEST PROJECT (ASTP)
OPERATIONS HANDBOOK

Circuit Breakers	Panel Location	When Opened	When Closed	Remarks
FLOAT BAG (all)	8	Prelaunch	After splashdown	Opened to ensure against inadvertent activation of float bag compressors and sea dye marker prior to splashdown.
ELS/CM SM SEP (2)	8	Postorbital insertion check	Prior to deorbit and entry	Opened to isolate ELS and CM SM SEP functions until needed.
PL VENT FLT/PL	8	Postorbital insertion check	After splashdown	Opened to ensure against inadvertent activation of postlanding vents.
SECS ARM (2)	8	Postorbital insertion check	During prelaunch, launch, docking, deorbit, and entry procedures	Opened to ensure against inadvertent activation of SECS functions.
EDS (all)	8	Post CSM/SLA separation panel configuration	Prelaunch	No further use after CSM/SLA separation.
RCS LOGIC (2)	8	Post S-IVB separation check	During prelaunch, launch, deorbit, and entry procedures	Opened to ensure against advertent CM/SM RCS transfer and/or CM RCS activation.
DOCK PROBE (2)	8	Before docking, probe removal, installation and final separation	Prelaunch and prior to docking probe operation	To ensure electrical power is not at docking ring electrical separation connector when docking ring is jettisoned.
F/C RAD (3)	226	Prelaunch	When required	Precludes inadvertent decrease in radiator area.

LIMITED USE CIRCUIT BREAKERS

5.1.2

NORMAL/BACKUP

APOLLO-SOYUZ TEST PROJECT (ASTP)
OPERATIONS HANDBOOK

Circuit Breakers	Panel Location	When Opened	When Closed	Remarks
PYRO BUS A&B BAT BUS A&B	229	Prelaunch	Only when required, if pyro bats indicate <31.5 vdc during bat check	Connects battery buses to pyro buses in event of pyro battery(s) failure.
MEI REL. PYRO (2)	229	Prelaunch	Only after splashdown	Opened to prevent premature main parachute release.
UVA EXP MNB	230	Prelaunch	Prior to UVA experiment (MA059)	No further use after experiment.
UVA COVER MNB	230	Prelaunch	Prior to UVA experiment (MA059)	No further use after experiment.
MN BUS INTERCONNECT (2)	250	Prelaunch	When required	Closed to interconnect CSM MN BUS A and B in a contingency.
ETE AC2 (3)	274	Prelaunch	Prior to ETE experiment activation (MA011)	No further use after experiment.
DS CONTROL BAT (2)	274	Prelaunch	Prior to docking and undocking operations	Opened after docking and final undocking operations.
DS MOTORS AC 1 & 2 (6)	274	Prelaunch	Prior to docking and undocking operations	Opened after docking and final undocking operations.
BAT BUS A&B MJA & B (2)	275	Prelaunch	When required	Closed to supply power to battery buses from main buses.
BAT BUS A&B BAT C (2)	275	Prelaunch	When required to connect bat C to bat bus A or B	Connected when bat C is used to back up failed bat A or B.

LIMITED USE CIRCUIT BREAKERS

APOLLO-SOYUZ TEST PROJECT (ASTP)
OPERATIONS HANDBOOK

Circuit Breakers	Panel Location	When Opened	When Closed	Remarks
MVA & B BAT C (2)	275	Prelaunch	Prior to deorbit and as required for bat A or B backup to main buses.	Opened to isolate bat C from main buses.
BAT BUS A&B PYRO BAT A&B (2)	275	Prelaunch	When required to connect pyro battery A or B to bat bus A or B	Closed to provide battery buses with backup source of power.
UPR SYS COMPR (both)	278	Prelaunch	After splashdown	Opened to ensure against inadvertent activation of float bag compressors.
DOCK RING SEP (2)	278	Prelaunch	Prior to dock ring jettison	No further use after dock ring jettison.

5.1.1.2

LIMITED USE CIRCUIT BREAKERS

NORMAL/BACKUP

APOLLO-SOYUZ TEST PROJECT (ASTP)
OPERATIONS HANDBOOK

STA/T STEP	PROCEDURE	PANEL	REMARKS
5.2	PROPULSION SYSTEMS		
	<p>Specific functions of the SPS and RCS must be monitored to assure operational readiness and capability. SPS and SM RCS monitoring checks are performed during post-orbital insertion check and at 4-hour intervals and after each SPS burn. In addition, the SM RCS monitoring check is performed prior to each SPS burn. The CM RCS monitoring check is performed during post-orbital insertion check and at 12-hour intervals and prior to entry.</p>		
5.2.1	SPS Monitoring Check		
DP	<p>SPS TEMP IND sw - He PNL, OXID LN SFS TEMP ind - 45°F to 80°F SPS PRESS IND sw - He, N2A, & N2B SPS He/N2 PRESS ind SPS He PRESS - 3750 psia max SPS N2 A PRESS - 2900 psia max SPS N2 B PRESS - 2900 psia max SPS PRESS IND sw - He SPS FUEL PRESS ind - 170-195 psia SPS OXID PRESS ind - 170-195 psia</p>	3	<p>Use A/B position if double heater operation required for temperature control.</p> <p>3600+50 psia at launch, decreases with each burn. 2900 psia at 130°F, decreases with each burn. 2900 psia at 130°F, decreases with each burn.</p> <p>Fuel and oxidizer tanks pressurized with helium prior to launch.</p>
	<p><u>CAUTION</u></p> <p>If ΔP between fuel and oxid >20 psi prior to critical SPS burn, repressurize prplnt tanks manually by placing SPS He VLV (both) - ON, ΔP between tanks >20 psi during burn may result in degraded performance, rough combustion, and/or engine failure.</p>		

SPS MONITORING CHECK

APOLLO-SOYUZ TEST PROJECT (ASTP)
OPERATIONS HANDBOOK

STA/T STEP	PROCEDURE	PANEL	REMARKS
DP	<p>SPS INJ VLV ind (4) - CLOSE</p> <p>SPS OXID QTY ind - N/A</p> <p>SPS FUEL QTY ind - N/A</p> <p>SPS OXID UNBAL ind - N/A</p> <p>OXID FLOW VLV PRIM - PRIM</p> <p>SPS He VLV (both) - AUTO</p> <p>SPS He VLV tb (both) - bp</p> <p>SYS TEST (2) - 5C</p> <p>SYS TEST ind - 1.3-5.0</p> <p>SYS TEST (2) - 6C, 7C, 8C</p> <p>SYS TEST ind - 1.3-3.7</p> <p>SYS TEST (2) - 3B</p>	3	<p>Each CLOSE indicates two propellant ball valves closed.</p> <p>PUGS deactivated.</p> <p>PUGS deactivated.</p> <p>PUGS deactivated.</p> <p>PUGS deactivated.</p> <p>Barber pole indicates helium isolation valve closed.</p> <p>Equivalent to +40° - 150°F SPS engine valve body temperature.</p> <p>Equivalent to 40 - 110°F SPS oxidizer feed line, SPS fuel check valve, and SPS oxidizer tank outboard temperatures.</p> <p>In addition to normal monitoring checks, all helium and propellant talkbacks for valves in use should be verified gray after any mechanical shock to CSM.</p>
CP	<p>SM RCS QUAD He tb (4) - gray [bp]</p> <p>SM RCS QUAD PRIM PRPLNT tb (4) - gray [bp]</p> <p>SM RCS QUAD SEC PRPLNT tb (4) - gray [bp]</p> <p>SM RCS PSM PRPLNT tb (4) - bp [gray]</p>	2	<p>Gray indicates both helium main isolation valves open in each quad.</p> <p>Gray indicates fuel and oxidizer isolation valves open</p> <p>Gray indicates fuel and oxidizer isolation valves open</p> <p>Barber pole indicates at least one PSM manifold to quad propellant (fuel or oxidizer) isolation valve closed.</p>

5.2.2 SM RCS Monitoring Check

NOTE

Data in [] applies when PSM is active.

SM RCS MONITORING CHECK

5.2.2

NORMAL BACKUP

APOLLO-SOYUZ TEST PROJECT (ASTP)
OPERATIONS HANDBOOK

STA/T STEP	PROCEDURE	PANEL	REMARKS
CP	<p>FSM He tb - bp [gray]</p> <p>FSM MANF ISOL tb - gray</p> <p>RCS IND sel - SM A, B, C, D</p> <p>SM RCS PKG TEMP ind - 115°-175°F (C/W 75°-205°F)</p> <p>SM RCS He TK PRESS ind - record (quad)</p> <p>SM RCS IND sw - PRPLNT QTY</p> <p>SM RCS SEC FUEL TK PRESS ind - 178-192 psia (quad)</p> <p>SM RCS PRPLNT QTY ind - record % (quad)</p> <p>When SM RCS SEC FUEL TK PRESS ind - 150 psia (quad)</p> <p>SM RCS SEC FUEL PRESS A(B, C, D) - OPEN</p> <p>RCS IND sel - PSM</p> <p>SM RCS PKG TEMP ind - zero</p> <p>SM RCS He TK PRESS ind - record (PSM)</p>	2	<p>Barber pole indicates at least one of two redundant helium isolation valves closed.</p> <p>Gray indicates both fuel and both oxidizer isolation valves open.</p> <p>Check each quad in turn.</p> <p>Temperature maintained by two redundant and separately selected package heater circuits, each thermostatically controlled between 115°F and 134°F. Above nominal temperature may occur during and after long jet firings. Prolonged cold soak may produce lower than nominal temperatures.</p> <p>Nominally 4150 psia before quad used.</p> <p>192-207 psia until quad used, after orbit insertion. Fuel line readout of primary fuel tank only, until secondary tank pressurized - then primary and secondary common manifold if quad isolation valves open.</p> <p>Indicates quad primary fuel quantity low. SM RCS status lights on at 145 psia.</p> <p>OPEN position is momentary. No talkbacks. Opens helium isolation valve at quad secondary fuel tank.</p> <p>Operational only when RCS IND selector at SM A, B, C, or D.</p> <p>Temperature variations cause excursions from nominal.</p>

SM RCS MONITORING CHECK

APOLLO-SOYUZ TEST PROJECT (ASTP)
OPERATIONS HANDBOOK

STA/T STEP	PROCEDURE	PANEL	REMARKS
CP	<p>SM RCS FUEL TK PRESS ind - 130-150 psia (before PSM activation)</p> <p>SM RCS FUEL TK PRESS ind - 178-192 psia (after PSM activation)</p> <p>SM RCS QTY ind - record % (PSM)</p> <p>RCS IND sw - MANF PRESS</p> <p>SM RCS FUEL MANF PRESS ind - 130-150 psia (before PSM activation)</p> <p>178-192 psia (after PSM activation)</p> <p>SM RCS OXID MANF PRESS ind - 150-170 psia (before PSM activation)</p> <p>178-192 psia (after PSM activation)</p> <p>101</p> <p>SYS TEST (2) - 10B</p> <p>SYS TEST ind - 1.0-3.5 vdc</p>	2	<p>Nominal pressure range for a fully loaded PSM. Partial loads will result in higher pressures.</p> <p>Regulated helium pressure common manifold readout.</p> <p>Propellant (fuel and oxidizer) distribution manifold pressures same as PSM 1 propellant tank servicing pressures, until used. Pressure ranges given far before PSM activation will result in higher pressures.</p> <p>Equivalent to 30° - 105°F SM RCS PSM fuel tank temperature. Temperature maintained by two redundant and separately selected heater circuits, each thermostatically controlled between primary 50°±3°F and secondary 55°±3°F.</p>
5.2.3	<p><u>CM RCS Monitoring Check</u></p> <p>CM RCS PRPLNT tb (both) - gray</p> <p>RCS IND sel - CM 1, 2</p> <p>CM RCS He TK TEMP ind - 45°-80°F</p> <p>Prior to CM RCS activation</p> <p>CM RCS He TK PRESS ind - 3900-4300 psia</p>	2	<p>Gray indicates fuel and oxidizer isolation valves open.</p> <p>Check both CM RCS system 1 and 2 in turn.</p> <p>Temperature variations cause pressure excursions from nominal.</p>

5.2.3

CM RCS MONITORING CHECK

NORMAL/BACKUP

APOLLO-SOYUZ TEST PROJECT (ASTP)
OPERATIONS HANDBOOK

STA/T STEP	PROCEDURE	PANEL	REMARKS
CP	CM RCS He MANF PRESS ind - 80-105 psia After CM RCS activation CM RCS He TK PRESS ind - 3600-3800 psia (after ~15 min) CM RCS He MANF PRESS ind - 287-302 psia SM RCS QTY ind - zero SYS TEST (2) - 4B, 5B, 6B, 7B, 8B, 9B SYS TEST ind - ambient (vdc)	2	<p>GSE servicing pressure monitored until system activated. Pressure varies with temperature and ullage. If manifold pressure drops suddenly, indicating a ruptured burst diaphragm, close CM RCS propellant isolation valves and then perform procedure for preheating jets (4.15.1.4) for 20 minutes. Procedure vents any propellant trapped between propellant isolation valves and jets by energizing jet valve direct coils.</p> <p>Operational only when RCS IND selector at SM A, B, C, D or at PSM 1.</p> <p>CM RCS engine injector valve temperatures of jets 12 (-R), 14 (-P), 16 (-Y), 21 (+R), 23 (+P), and 25 (+Y) respectively.</p>

CM RCS MONITORING CHECK

5.3 ELECTRICAL POWER SYSTEM

EPS Management

The normal EPS configuration will be with two fuel cells on main bus A and one on main bus B, e.g., FC 1 and 2 on MNA and FC 3 on MNB. If one fuel cell is to be removed from buses, one of two configurations may be assumed. The prime configuration is one fuel cell per bus; for example, fuel cell 1 to main bus A and fuel cell 3 to main bus B. This configuration requires a dual inverter configuration and subsequent load balancing after fuel cell configuration has been established. The second configuration is to have two fuel cells paralleled to buses. This configuration should not be assumed unless equipment malfunction does not permit load balancing or one of the remaining fuel cells performance is degraded.

Standby operation (in-line heaters, reactants and pumps remain on) may be used when powering down spacecraft, as a corrective action for fuel cell malfunctions, or in the event it is desired to hold a fuel cell in reserve for future use. Batteries and remaining fuel cells should be normal when a fuel cell is placed on standby operation (open circuit). In-line heaters and pumps should not be turned off unless fuel cell is to be shut down. If, during the mission, it becomes necessary to conserve cryogenics, electrical loads should be reduced which will in turn decrease flow of cryogenics to fuel cells. In an emergency situation, consideration may be given to deactivate a fuel cell (in-line heaters, pumps, and loads off) to conserve cryogenics. During deactive period, continuous monitoring of the fuel cell system will not necessarily assure a reactivation capability and there exists a possibility of complete loss of the fuel cell.

The prime inverter configuration is to have inverter 1 powering ac bus 1 and inverter 2 powering ac bus 2, with inverter 3 as backup. This configuration permits optimum bus isolation; however, reliability of the inverter permits single inverter operation to both ac buses if cryogenics are to be conserved. When a single inverter is used to power both ac buses, there will be a transient when it is tied to the second ac bus. This could cause spurious RCS jet firings and momentary loss of telemetry.

Entry batteries A and B will normally supply main bus A and main bus B respectively with battery C as backup. The batteries (2) should be on during countdown, lift-off, and all delta V maneuvers. Battery C will supply the buses prior to deorbit burn and as required throughout the mission.

5.3

ELECTRICAL POWER SYSTEM

NORMAL/BACKUP

Battery C will be connected to buses as required to provide two-battery configuration for delta V maneuvers. All three batteries are to be used during final deorbit burn.

The battery charging cycle should be terminated when either the battery bus voltage indicated on PCM exceeds 39.5 vdc, charger current has decreased to 0.93 amps, or when 100 percent of the expended energy has been replaced. This presumes charger current PCM data availability, and integration of charge current on the ground with STDN advice to crew when 100 percent of charge is returned. If PCM link is lost, voice readouts of the onboard charger DC AMPS indicator will be required at intervals of 20 to 30 minutes for integration on the ground. Charging may be resumed if interrupted before achieving terminal conditions previously listed. Normal practice is to continue any charge to completion.

Batteries will be checked prior to each GO/NO-GO flight decision, prior to deorbit burn, and in routine periodic checks as required.

The onboard readout will be prime throughout EPS checks.

Application of control voltage less than 22 vdc to any motor switch should be terminated after 10 seconds with repeated applications no more often than once each five minutes. (Under normal bus conditions, motor switches are limited to six transfers in any six-minute period.)

Fuel cell periodic verification consists of updating onboard data and comparing respective fuel cell performance for a particular phase, with established history of the powerplant.

Normal fuel cell purge requirements will be established in flight on the basis of prelaunch purity tests and elapsed amp-hours since previous purge. Purging is accomplished by sequentially purging O₂ (for 120 seconds) then H₂ (for 80 seconds).

The time required for the H₂ vent line heater activation prior to H₂ purge has been set at 20 minutes. This time is flexible in that a purge may be attempted with less heater time (for example, a contingency corrective action) with no immediate adverse effect on the powerplant.

ELECTRICAL POWER SYSTEM

APOLLO-SOYUZ TEST PROJECT (ASTP)
OPERATIONS HANDBOOK

STA/T STEP	PROCEDURE	PANEL	REMARKS
5.3.1	<u>Cryogenic Pressure-Quantity Check</u>		
CP	CRYO H2 PRESS ind (both) - 225-260 psia O2 PRESS IND sw - SURGE TK CRYO O2 PRESS 1 ind - 865-935 psia O2 PRESS IND sw - TK 1 CRYO O2 PRESS ind (both) - 865-935 psia CRYO H2 QTY ind (both) - record CRYO O2 QTY ind (both) - record	2	Indicates H2 tank 1 and 2 pressure. Indicates surge tank O2 pressure Indicates O2 tank 1 and 2 pressure. Nominal per mission profile curve, 100% maximum indicates full tank (28 lbs each tank). Nominal per mission profile curve, 100% maximum indicates full tank (320 lbs each tank).
5.3.2	<u>FC Power Plant Check</u>		
DP	FC HTRS (all) - on (up) FC RAD tb (all) - gray FC REACS tb (all) - gray FC FC IND sel - 1, 2, 3 FC H2 FLOW ind - 0.03-0.15 lb/hr FC O2 FLOW ind - 0.25-1.2 lb/hr FC SKIN TEMP ind - 390°-440°F FC COND EXH TEMP ind - 150°-175°F FC pH HI tb - gray	3	Enables electronic switches which automatically apply or remove power to fuel cell heaters. Gray indicates fuel cell radiator panel not bypassing flow. Gray indicates both reactant valves open for each fuel cell. Flow limits are proportional to individual fuel cell currents and can be approximated by fuel cell O2 flow = (amps x 2.0)/100, and fuel cell H2 flow = (amps x 2.5)/1000. Gray indicates pH factor normal.
5.3.2			

FC POWER PLANT CHECK

5.3.2

NORMAL/BACKUP

APOLLO-SOYUZ TEST PROJECT (ASTP)
OPERATIONS HANDBOOK

STA/T STEP	PROCEDURE	PANEL	REMARKS
5.3.3	<u>D-C Voltage-Amperage Check</u>		
DP	MN BUS TIE (2) - OFF (verify) SM PWR SOURCE 1 & 2 MNA tb (2) - gray SM PWR SOURCE 3 MNA tb - bp	5 3	Gray indicates fuel cells 1 and 2 connected to main bus A. Barber pole indicates fuel cell 3 disconnected from main bus A.
	SM PWR SOURCE 1 & 2 MNB tb (2) - bp SM PWR SOURCE 3 MNB tb - gray		Barber pole indicates fuel cells 1 and 2 disconnected from main bus B. Gray indicates fuel cell 3 connected to main bus B.
	DC IND sel - SM SOURCE 1, 2, 3 DC AMPS ind - record amps		Record dc amps for each fuel cell.
	DC IND sel - MNA, B DC VOLTS ind - 26.5-31 vdc (record)		Record dc volts for main buses A and B.
	DC IND sel - BAT BUS A, B, & BAT C DC VOLTS ind - 31.5-38.0 vdc DC AMPS ind - <3.0 amps		Voltage indication may be different than shown when charging battery.
CP	SYS TEST (2) - 3B SYS TEST ind - 3.4-4.1 vdc	101	Verifies battery relay bus voltage 30.5 to 37.0 vdc and verifies system test indicator. Perform if convenient.
DP	DC IND sel - PYRO BAT A, B DC VOLTS ind - 31.5-38.0 vdc DC IND sel - MNA	3	Check pyro batteries A and B once every 24 hours.
5.3.4	<u>A-C Voltage Check</u>		
	AC IND sel - BUS 1, 2, ØA, B, C AC VOLTS ind - 113-117 vac		

A-C VOLTAGE CHECK

APOLLO-SOYUZ TEST PROJECT (ASTP)
OPERATIONS HANDBOOK

STA/T STEP	PROCEDURE	PANEL	REMARKS
5.3.5	<u>Battery A (B, C) Charging</u>		
DP	MN BUS TIE (2) - OFF	5	If battery charge started immediately after discharge, charger current may be high and/or voltage may be low.
	cb BAT RLY BUS BAR A(B) - open (except BAT C charge)		Placing MN BUS TIE switches OFF disconnects battery from main buses.
	cb BAT BUS A & B PYRO BAT A & B(2) - open (verify)	275	
	cb BAT BUS A & B BAT C(2) - open (verify)		
	cb PYRO BUS A & B BAT BUS A & B(2) - open (verify)	229	
	DC IND sel - BAT CHGR	3	
	BAT CHG - A, B or C		
	DC VOLTS ind - 37.5-39.5 vdc		
	BAT CHG - OFF (at STDN request or when ind reads 0.93 amp)		
	DC VOLTS ind reads 39.5 vdc or DC AMPS ind reads 0.93 amp)		
	cb BAT RLY BUS BAT A(B) - close (except BAT C charge)	5	
	If pyro battery A or B charge desired		If D-C Voltage Check indicates pyro battery A(B) requires charging, possibility of malfunction exists in pyro battery circuits, and should be investigated.
	MN BUS TIE (2) - OFF		
	cb BAT RLY BUS BAT A(B) - open		
	cb BAT BUS A(B) BAT A(B) - open	275	
	cb BAT BUS A(B) BAT C - open (verify)		
	cb BAT BUS A(B) PYRO BAT A(B) - close		
	DC IND sel - BAT CHGR	3	
	BAT CHG - A(B)		

5.3.5

BATTERY A (B, C) CHARGING

NORMAL/BACKUP

APOLLO-SOYUZ TEST PROJECT (ASTP)
OPERATIONS HANDBOOK

STA/T STEP	PROCEDURE	PANEL	REMARKS
DP	<p>DC VOLTS ind - 37.5-39.5 vdc BAT CHG - OFF (at STDN request or when DC VOLTS ind reads 39.5 vdc or DC AMPS ind reads 0.93 amp) cb BAT BUS A(B) PYRO BAT A(B) - open cb BAT BUS A(B) BAT A(B) - close cb BAT RLY BUS BAT A(B) - close</p>	<p>3 275 5 3</p>	
CP	<p>DC IND sel - MNA SYS TEST (2) - 2B SYS TEST ind - <2.3 vdc (after sea level ambient press ≈ 14 psia has been vented)</p> <p>If >2.3 vdc, notify STDN If ≈0.0 vdc, BAT VENT vlv - CLOSED, notify STDN SYS TEST (2) - 3B</p>	<p>101</p>	
DP	<p>5.3.6 FC Power Plant Purging</p> <p>1 O2 purging FC IND sel - 1, 2, or 3 FC 1, 2, or 3 PURG - 02 (2 min) FC O2 FLOW ind - flow incr ≈0.6 lb/hr FC 1, 2, or 3 PURG - OFF</p> <p>2 H2 purging H2 PURG LINE NCR - on (up), 20 min prior to purge FC IND sel - 1, 2, or 3 FC 1, 2, or 3 PURG - H2 (1 min, 20 sec)</p>	<p>3</p>	<p>Refer to purge information at beginning of 5.3. Purging is performed as determined by real time decision.</p> <p>O2 flow rate will increase ≈0.6 lb/hr.</p>

FC POWER PLANT PURGING

APOLLO-SOYUZ TEST PROJECT (ASTP)
OPERATIONS HANDBOOK

STA/T STEP	PROCEDURE	PANEL	REMARKS
DP 2	FC H2 FLOW ind - flow incr & peg meter at upper limit of 0.2 lb/hr FC 1, 2, or 3 PURG - OFF After 10 min H2 PURG LINE HTR - OFF	3	H2 flow rate will increase ≈ 0.7 lb/hr.
5.3.7	<u>Fuel Cell Load Disconnect</u> (Example using FC 2)		This procedure is presented with the following assumptions: Fuel cells 1 and 2 powering dc main bus A. Fuel cell 3 powering dc main bus B. Requires load balancing.
a.	Prior to Disconnect Ensure that at least one FC is powering each main bus FC disconnect (1) Prime configuration		Fuel cell 2 is now disconnected from both dc main buses.
	SM PWR SOURCE 2 MNA - OFF SM PWR SOURCE 2 MNB - OFF (verify)		Barber poles indicate fuel cell 2 is disconnected from main bus A and main bus B.
	SM PWR SOURCE 1 MNA tb - gray		Gray indicates fuel cell is connected to main bus A.
	SM PWR SOURCE 1 MNB tb - bp		Barber pole indicates fuel cell 1 is disconnected from main bus B.
	SM PWR SOURCE 3 MNA tb - bp		Barber pole indicates fuel cell 3 is disconnected from main bus A.
	SM PWR SOURCE 3 MNB tb - gray		Gray indicates fuel cell 3 is connected to main bus B.

5.3.7

FUEL CELL LOAD DISCONNECT

NORMAL/BACKUP

APOLLO-SOYUZ TEST PROJECT (ASTP)
OPERATIONS HANDBOOK

STA/T STEP	PROCEDURE	PANEL	REMARKS
IF	(2) Secondary configuration SM PWR SOURCE 1 MNB - on (up) SM PWR SOURCE 3 MNA - on (up)	3	This configuration is assumed if load balancing cannot be obtained. On position is momentary. On position is momentary.
ALL	MASTER ALARM pb/lt (3) - on	1,3,122	MASTER ALARM and SM PWR DISC lights are energized when SM PWR SOURCE main bus switches pass through center position when placing fuel cells on main buses.
CP	SM PWR DISC lt - on (momentary)	2	
ALL	MASTER ALARM pb/lt - push, out	1,3,122	
CP	C/W lts (all) - out	2	
DP	SM PWR SOURCE 2 MNA - OFF SM PWR SOURCE 2 MNB - OFF (verify)	3	Fuel cell 2 disconnected from both dc main buses. Fuel cells 1 and 3 paralleled to both dc main buses.
	SM PWR SOURCE 1 MNA & B tb (2) - gray		Gray indicates fuel cell 1 connected to main buses A and B.
	SM PWR SOURCE 3 MNA & B tb (2) - gray		Gray indicates fuel cell 3 connected to main buses A and B.
	SM PWR SOURCE 2 MNA & B tb (2) - bp		Barber poles indicate fuel cell 2 disconnected from main buses A and B.
b.	Return FC to Normal Configuration FC to bus connection SM PWR SOURCE 2 MNA - on (up)		On position is momentary.

FUEL CELL LOAD DISCONNECT

APOLLO-SOYUZ TEST PROJECT (ASTP)
OPERATIONS HANDBOOK

STA/T STEP	PROCEDURE	PANEL	REMARKS
ALL CP	MASTER ALARM pb/lt (3) - on SM PWR DISC lt - on (momentary)	1,3,122 2	MASTER ALARM and SM PWR DISC lights are energized when SM PWR SOURCE main bus switches pass through center position when placing fuel cells on main buses.
ALL CP	MASTER ALARM pb/lt - push, out C/W lts (all) - out	1,3,122 2	
DP	SM PWR SOURCE 1 MNB - OFF SM PWR SOURCE 3 MNA - OFF	3	Fuel cells returned to normal configuration (fuel cell 1 and 2 powering dc main bus A and fuel cell 3 powering dc main bus B).
	SM PWR SOURCE 2 MNA tb - gray SM PWR SOURCE 2 MNB tb - bp		Gray indicates fuel cell 2 connected to main bus A, barber pole indicates fuel cell 2 disconnected from main bus B.
	SM PWR SOURCE 1 MNA tb - gray		Gray indicates fuel cell 1 connected to main bus A.
	SM PWR SOURCE 1 MNB tb - bp		Barber pole indicates fuel cell 1 disconnected from main bus B.
	SM PWR SOURCE 3 MNA tb - bp		Barber pole indicates fuel cell 3 disconnected from main bus A.
	SM PWR SOURCE 3 MNB tb - gray		Gray indicates fuel cell 3 connected to main bus B.
5.3.8	<u>Inverter Changeover</u>		Normal operation throughout mission will be with 2 inverters operating. During drifting flight, a single inverter is adequate to power both ac buses; however, two-inverter operation is assumed, providing maximum bus isolation.

5.3.8

INVERTER CHANGEOVER

NORMAL/BACKUP

APOLLO-SOYUZ TEST PROJECT (ASTP)
OPERATIONS HANDBOOK

STA/T STEP	PROCEDURE	PANEL	REMARKS
	<p>Ensure at least one inv on each ac bus at all times (if available).</p> <p><u>WARNING</u></p> <p>a. Dual Inv (No. 1 & 2) Oper AC2 RSET - OFF</p> <p>INV 2 - MNB</p>	3	<p>If 3 inverters are switched onto one ac bus, loss of ac power to that bus will result.</p> <p>This procedure is presented with the assumption that inverter 1 is powering ac bus 1 and 2.</p> <p>During dual inverter operation, inverter connected to dc main bus A should always power ac bus 1 and inverter connected to dc main bus B should always power ac bus 2, to preclude loss of all ac and dc power to SCS in event of single dc main bus failure.</p>
DP	<p>INV 1 AC2 - OFF</p> <p>INV 2 AC2 - on (up)</p>		<p>S-band phaselock will be lost upon switching inverters.</p> <p>Inverter 1 now powering ac bus 1 and inverter 2 powering ac bus 2. Rapid performance of inverter switching sequence may initiate MASTER ALARM pb/lt when inverter is connected to bus.</p>
ALL	<p>AC2 RSET - RSET</p> <p>MASTER ALARM pb/lt (3) - on</p> <p>MASTER ALARM pb/lt - push</p> <p>MASTER ALARM pb/lt (3) - out</p> <p>C/W lts (all) - out</p> <p>Perform AC Voltage Check, 5.3.4</p>	1,3,122	<p>RSET position is momentary.</p> <p>Placing AC1 or 2 RSET switch to RSET and releasing ensures a MASTER ALARM pb/lt - on. Placing AC1 or 2 RSET to center will cause random activation of MASTER ALARM pb/lt.</p>
CP DP		2	

INVERTER CHANGEOVER

APOLLO-SOYUZ TEST PROJECT (ASTP)
OPERATIONS HANDBOOK

STA/T STEP	PROCEDURE	PANEL	REMARKS
DF	b. Single Inv Oper AC2 RSET - OFF INV 2 - OFF INV 2 AC2 - OFF INV 1 AC2 - on (up)	3	This procedure is presented with the assumption that inverter 1 is powering ac bus 1 and inverter 2 is powering ac bus 2. S-band phaselock will be lost upon switching inverters.
ALL	AC2 RSET - RSET MASTER ALARM pb/lt (3) - on MASTER ALARM pb/lt - push MASTER ALARM pb/lt (3) - out C/W lts (all) - out Perform AC Voltage Check, 5.3.4	1,3,122	Inverter 1 now powering ac bus 1 and ac bus 2. Rapid performance of inverter switching sequence may initiate MASTER ALARM pb/lt when inverter is connected to bus. RSET position is momentary.
CP DP	c. Stby Inv (No. 3) Check or Oper AC2 RSET - OFF INV 2 - OFF INV 3 - MWB INV 2 AC2 - OFF	2 3	Placing AC1 or 2 RSET switch to RSET and releasing ensures a MASTER ALARM pb/lt - on. Placing AC1 or 2 RSET to center will cause random activation of MASTER ALARM pb/lt. This procedure is presented with the assumption that inverter 1 is powering ac bus 1 and inverter 2 is powering ac bus 2. When switching inverter 3 from one main dc bus to the other, pause momentarily in OFF position. S-band phaselock will be lost upon switching inverters.

5.3.8

INVERTER CHANGEOVER

NORMAL/BACKUP

APOLLO-SOYUZ TEST PROJECT (ASTP)
OPERATIONS HANDBOOK

STA/T STEP	PROCEDURE	PANEL	REMARKS
EE	INV 3 AC2 - on (up)	3	Rapid performance of inverter switching sequence may initiate MASTER ALARM pb/lt when inverter is connected to bus.
	AC2 RSET - RSET		RSET position is momentary.
ALL	MASTER ALARM pb/lt (3) - on MASTER ALARM pb/lt - push MASTER ALARM pb/lt (3) - out C/W lts (all) - out	1,3,122	Placing AC1 or 2 RSET switch to RSET and releasing ensures a MASTER ALARM pb/lt - on. Placing AC1 or 2 RSET to center will cause random activation of MASTER ALARM pb/lt.
CP		2	
DP	Perform AC Voltage Check, 5.3.4 If stby inv check Go to dual inv (No. 1 & 2) oper, 5.3.8a, & set INV 3 - OFF	3	Standby inverter (No. 3) check should be performed every 24 hours.
5.3.9	<u>H2 Manual Fan Operation</u> <u>CAUTION</u> In the following step, if CRYO PRESS lt illuminates, do not set H2 FANS - off (ctr) or proceed to next step until lt extinguishes. H2 FANS both - ON, then off (ctr) sequentially for 1 min prior to and subsequent to crew rest periods.		Manual H2 fan operation should be used during flight to prevent possible cryo pressure control motor switch arcing, which may cause a-c inverter a-c bus disconnect.

H2 MANUAL FAN OPERATION

5.4 ENVIRONMENTAL CONTROL SYSTEM

ECS systems management procedures are divided into two categories. The first category consists of five procedures, described in steps 1 through 5, that are conducted at specific time intervals.

1. An ECS monitoring check is recommended every hour from time the SC attains orbit until CSM separation. This check provides crew with latest status of the ECS.
2. A redundant component check is accomplished at 24-hour intervals to determine operational status of certain ECS redundant components and secondary water-glycol loop. The test will reveal any inoperative or malfunctioning components that might have been selected for use later in the mission. Several redundant components are not checked, however, because of excessive use of oxygen, a means of selection not incorporated, or lack of direct indication.
3. Replacement of one CO₂-odor absorber filter is required on an alternate basis, at 12-hour intervals, for the ECS to remain within prescribed metabolic limit. Filters are also changed if CO₂ partial pressure exceeds 7.6 mm Hg.
4. It is recommended that at 24-hour intervals the debris screen on suit circuit return valve be checked and cleaned as necessary.
5. It is recommended that chlorine and a buffer chemical be individually injected into potable water supply every 24 hours to maintain potability. There is a 10-ampoule supply of each chemical on the CM. Should a condition exist where either glycol evaporator is in use and waste water tank is empty, chlorine and buffer injections should be postponed.

The second category consists of procedures, described in steps 1 through 13, that are accomplished at random intervals or only as required.

1. PGA/shirtsleeve mode changes require certain precautions to be taken regarding suit power switch settings, communication functions and ECS adjustments. This applies whether the mode change is from PGA-to-shirtsleeve, shirtsleeve-to-PGA, or full PGA to partially suited mode.

5.4

ENVIRONMENTAL CONTROL SYSTEM

NORMAL/BAY

APOLLO-SOYUZ TEST PROJECT (ASTP)
OPERATIONS HANDBOOK

STA/T STEP	PROCEDURE	PANEL	REMARKS
	<p>10. Procedural data is provided for donning and doffing the emergency oxygen masks.</p>		
	<p>11. Data for servicing the gas separator cartridges is provided. Separator cartridges are used as a backup for normal system H2/H2O separator.</p>		
	<p>12. The steps required to activate or deactivate the primary glycol evaporator are provided. Such action may be necessary to prevent navigation perturbations due to steam venting or for any other reason.</p>		
	<p>13. Procedures are provided for checking CM, cabin for leaks prior to rest periods and following completion of eating and overboard dumps.</p>		
5.4.1	<u>ECS Monitoring Check</u>		
CP	<p>SUIT CAB ΔP ind - -1.0 to -3.5 in H2O O2 FLOW ind - 0.2-0.45 lb/hr O2 PRESS IND sw - SURGE TK CRYO O2 PRESS 1 ind - 865-935 psia O2 PRESS IND sw - TK 1 REPRESS O2 PRESS ind - >865 psia ECS RAD tb - gray</p>	2	<p>O2 flow may be as high as 1.0 lb/hr (pegged) prior to completion of cabin purge.</p>
	<p>XXXXXXXXXXXXXXXXXXXXXXXXXXXXXXXXXXXX X If ECS RAD tb - 2 RAD FLOW CONT AUTO - 1 until tb gray (≈20 sec), then AUTO</p>	602 2	<p>Gray indicates No. 1 flow proportioning valve is controlling flow.</p>
	<p>If tb cannot be reset RAD FLOW CONT AUTO - 1</p>		<p>Attempt resetting talkback before assuming radiator proportioning malfunction.</p>

ECS MONITORING CHECK

APOLLO-SOYUZ TEST PROJECT (ASTP)
OPERATIONS HANDBOOK

STA/T STEP	PROCEDURE	PANEL	REMARKS
CP	<p>RAD PRIM OUT TEMP ind - within correct range</p> <p>RAD FLOW CONT AUTO - AUTO</p> <p>RAD PRIM OUT TEMP ind - outside correct range</p> <p>Refer to ECS Malfunction Procedure PRIM ECS RAD OUT TEMP HIGH, in the Flight Data File</p> <p>XXXXXXXXXXXXXXXXXXXXXXXXXXXXXXXXXXXX</p> <p>ECS IND sel - PRIM</p> <p>RAD PRIM IN TEMP ind - 60°-90°F</p> <p>RAD PRIM OUT TEMP ind - -12° to +65°F</p> <p>PRIM GLY EVAP OUT TEMP ind - 38°-50.5°F (EVAP AUTO); 42°-67°F (EVAP OFF)</p> <p>PRIM GLY EVAP STM PRESS ind</p> <p>When boiling - 0.09-0.14 psia</p> <p>Not boiling - 0.14 psia</p> <p>PRIM GLY DISCH PRESS ind - 39-52 psig</p> <p>SUIT TEMP ind</p> <p>Without evap - 45°-70°F</p> <p>With evap - 45°-55°F</p> <p>CAB TEMP ind - 70°-80°F</p> <p>SUIT PRESS ind - CAB PRESS ind</p> <p>CAB PRESS ind - 4.7-5.3 psia</p>	2	<p>Correct range indicates talkback malfunction only, with both proportioning systems and failure detection circuit operable.</p> <p>Cabin pressure will be 5.6 to 6.2 psia after launch and continuously decrease until cabin pressure regulator activates and controls to 4.7 to 5.3 psia.</p>

5.4.1

ECS MONITORING CHECK

NORMAL/BACKUP

APOLLO-SOYUZ TEST PROJECT (ASTP)
OPERATIONS HANDBOOK

STA/T STEP	PROCEDURE	PANEL	REMARKS
CP	C02 PP ind - <7.6 mm Hg SUIT COMPR AP ind - 0.3-0.4 psid PRIM ACCUM QTY ind - 30-65% If quantity <30% PRIM ACCUM FILL vlv - ON until 40-55% is reached	2 379,2	
CP,DP	H2O QTY IND sw - POT	2	
CP	POT H2O QTY ind - 10-100% H2O QTY IND sw - WASTE WASTE H2O QTY ind - 15-90%		
	<u>5.4.2 ECS Redundant Component Check</u>		
1	Suit compressor	4	
DP	SUIT COMPR (both) - redundant compr	2	
CP	SUIT COMPR AP ind - 0.3-0.4 psid		
2	Suit demand regulators	380	
AC	DEMAND REG sel - 1 Close demand reg cabin bleed port with finger	2	Obstruct bleed flow only long enough to obtain momentary high flow.
CP	O2 FLOW ind - momentary incr	380	
AC	DEMAND REG sel - 2 Close demand reg cabin bleed port with finger	2	Obstruct bleed flow only long enough to obtain momentary high flow.
CP	O2 FLOW ind - momentary incr	380	
AC	DEMAND REG sel - BOTH		
3	Main O2 regulators	351	
CP	MN REG B - close EMER CAB PRESS sel - 1 EMER CAB PRESS TEST pb - push		Press-to-test pushbutton held only long enough to obtain momentary high flow.

ECS REDUNDANT COMPONENT CHECK

APOLLO-SOYUZ TEST PROJECT (ASTP)
OPERATIONS HANDBOOK

STA/T STEP	PROCEDURE	PANEL	REMARKS
CP	<p>O2 FLOW ind - pegged high MN REG B - OPEN MN REG A - close EMER CAB PRESS sel - 2 EMER CAB PRESS TEST pb - push</p>	<p>2 351</p>	<p>Press-to-test pushbutton held only long enough to obtain momentary high flow.</p>
	<p>O2 FLOW ind - pegged high MN REG A - OPEN EMER CAB PRESS sel - BOTH (OFF if all crewmen suited)</p>	<p>2 351</p>	
4	<p>H2O accumulators SUIT H2O ACCUM AUTO - redundant accum O2 FLOW ind - monitor for momentary (10 sec) incr</p>	<p>2</p>	<p>Allow up to 10 minutes for accumulator stroking.</p>
5	<p>Urine dump nozzle heaters WASTE H2O DUMP - redundant heater URINE DUMP - redundant heater STDN reports no significant change in urine & water dump nozzle temperatures</p>	<p>101</p>	<p>Nozzle temperatures are telemetered only. Temperature decrease indicates heater failure; however, if nozzles are facing sun, decrease may not be immediate.</p>
6	<p>Open coolant control atten panel <u>WARNING</u> SUIT FLOW RELF vlv must remain OFF throughout mission or swelling of CO2 odor absorber filters may result.</p>	<p>382</p>	<p>Covers panel 382. Opened to perform part of secondary glycol loop check.</p>

5.4.2

ECS REDUNDANT COMPONENT CHECK

NORMAL/BACKUP

APOLLO-SOYUZ TEST PROJECT (ASTP)
OPERATIONS HANDBOOK

STA/T STEP	PROCEDURE	PANEL	REMARKS
7	Secondary glycol loop		Coldplates are not provided in secondary glycol loop for DSE and G&N. Usage time for noncoldplated items is as follows: DSE: 2 hours ON, 1 hour OFF. G&N: 1.9 hours ON, 9.2 hours OFF.
CP	GLY TO RAD SEC vlv - BYP SEC EVAP H2O CONT - AUTO ECS IND sel - SEC SEC COOL PUMP - AC1 SEC GLY DISCH PRESS ind - 39-52 psig SEC ACCUM QTY ind - 30-60% SEC COOL EVAP - EVAP SEC GLY EVAP STM PRESS ind When boiling - 0.09-0.14 psia Not boiling - >0.14 psia After 5 min SEC GLY EVAP OUT TEMP ind - 38°-50.5°F SEC COOL PUMP - AC2 SEC GLY DISCH PRESS ind - 39-52 psig SEC COOL EVAP - RSET for 58 sec min, then off (ctr) ECS IND sel - PRIM SEC COOL PUMP - off (ctr)	377 382 2	RSET closes steam pressure control valve. Steam pressure valve requires 58 seconds from full open to full close.
8	Secondary radiator leak check Monitor SEC ACCUM QTY ind GLY TO RAD SEC vlv - NORM for 30 sec, then BYP SEC ACCUM QTY ind - no change	377 2	

ECS REDUNDANT COMPONENT CHECK

APOLLO-SOYUZ TEST PROJECT (ASTP)
OPERATIONS HANDBOOK

STA/T STEP	PROCEDURE	PANEL	REMARKS																																		
CP	9 Close coolant control atten panel		Covers panel 382.																																		
DP	10 Primary glycol pumps GLY PUMPS - redundant pump	4	Switch to pump opposite that on at beginning of test. This verifies primary loop pump operation.																																		
CP	PRIM GLY DISCH PRESS ind - 39-52 psig PRIM ACCUM QTY ind - 30-65%	2																																			
	5.4.3 <u>CO2 Absorber Filter Replacement</u>																																				
	<u>CAUTION</u> Connect ground wire when removing or replacing filter from canister or storage. Obtain unused filter																																				
			<table border="1"> <thead> <tr> <th>Filter No.</th> <th>Storage Container</th> <th>Filter No.</th> <th>Storage Container</th> </tr> </thead> <tbody> <tr> <td>1</td> <td rowspan="2">Canister A</td> <td>14</td> <td rowspan="2">D4</td> </tr> <tr> <td>2</td> <td>15</td> </tr> <tr> <td>3</td> <td rowspan="2">Canister B</td> <td>13</td> <td rowspan="2">D4</td> </tr> <tr> <td>4</td> <td>17</td> </tr> <tr> <td>5</td> <td rowspan="8">CM (TBD)</td> <td>15</td> <td rowspan="8">D4</td> </tr> <tr> <td>6</td> <td>16</td> </tr> <tr> <td>7</td> <td>17</td> </tr> <tr> <td>8</td> <td>18</td> </tr> <tr> <td>9</td> <td>19</td> </tr> <tr> <td>10</td> <td>20</td> </tr> <tr> <td></td> <td>21</td> </tr> <tr> <td></td> <td>22</td> </tr> </tbody> </table>	Filter No.	Storage Container	Filter No.	Storage Container	1	Canister A	14	D4	2	15	3	Canister B	13	D4	4	17	5	CM (TBD)	15	D4	6	16	7	17	8	18	9	19	10	20		21		22
Filter No.	Storage Container	Filter No.	Storage Container																																		
1	Canister A	14	D4																																		
2		15																																			
3	Canister B	13	D4																																		
4		17																																			
5	CM (TBD)	15	D4																																		
6		16																																			
7		17																																			
8		18																																			
9		19																																			
10		20																																			
		21																																			
		22																																			

5.4.3
CO2 ABSORBER FILTER REPLACEMENT

5.4.3

NORMAL BACKUP

APOLLO-SOYUZ TEST PROJECT (ASTP)
OPERATIONS HANDBOOK

STA/T STEP	PROCEDURE	PANEL	REMARKS
CP	<p>Open CO2 canister atten panel CO2 CSTR DIVERT vlv - up (or dn)</p> <p style="text-align: center;"><u>CAUTION</u></p> <p>Apply pressure to latching handle to allow pressure interlock pin to withdraw, otherwise latching handle may not disengage.</p> <p>Canister manual bleed vlv - press Cover latching handle - unlock Replace used filter Cover latching handle - lock CO2 CSTR DIVERT vlv - ctr Close CO2 canister atten panel Stow used filter Stow excess shims</p>	350	<p>Handle placed up for canister B filter change, down for canister A filter change.</p>
AC	<p>5.4.4 <u>Debris Screen Check</u></p> <p>a. SUIT RETURN vlv screen Open coolant control atten panel</p>	380	<p>For stowage, reference NASA document (TBD).</p> <p>Lint or other debris on screens may reduce flow substantially.</p> <p>Covers panel 382 and SUIT RETURN valve screen.</p>
CP	<p style="text-align: center;"><u>WARNING</u></p> <p>SUIT FLOW RELF vlv must remain OFF throughout mission or swelling of CO2 odor absorber filters may result.</p>	382	

DEBRIS SCREEN CHECK

APOLLO-SOYUZ TEST PROJECT (ASTP)
OPERATIONS HANDBOOK

STA/T STEP	PROCEDURE	PANEL	REMARKS
AC CP AC CP	<p>If debris is present SUIT RETURN vlv - CLOSE PUSH Clean screens SUIT RETURN vlv - OPEN PULL Close coolant control atten panel</p>	380	
b.	<p>Cabin ht exch inlet screen CAB FAN (both) - OFF (verify) Check cabin ht exch inlet screen If debris present - clean screen</p>	2	
5.4.5	<p><u>Potable Water Chlorination</u></p> <p style="text-align: center;"><u>CAUTION</u></p> <p>If waste water quantity is approaching empty (read $\leq 15\%$) and either glycol evaporator is in operation, chlorination procedure will not be performed, as impairment of evaporator efficiency may result.</p>		Chlorine concentration must not exceed 6 ppm.
1	<p>Check POT H2O QTY ind - if $> 85\%$, withdraw 8 oz of water</p>		It is necessary to withdraw water to allow space for water flow into tank after chlorine and buffer injection.
2	<p>Retrieve chlorination unit</p>		For storage, reference NASA document (TED).
3	<p>Remove chlorination port cap</p>		
ALL			

5.4.5

POTABLE WATER CHLORINATION

NORMAL/BACKUP

APOLLO-SOYUZ TEST PROJECT (ASTP)
OPERATIONS HANDBOOK

STA/T STEP	PROCEDURE	PANEL	REMARKS
ALL	<p>XXX X Chlor port leaking Use tools W & 3 Insert tool 3 only 1/4 inch into insert socket Tighten (CW) 1/4 turn with tools W & 3 XXX X</p>		Prevents torque set driver puncturing grommet.
CP	<p>4 Attach needle assy to inject port</p>	352	
	<p>5 Insert chlorine ampoule into casing</p>		Chlorine ampoules color-coded red.
	<p>6 Connect knob assy & rotate (CW) until piston contacts ampoule firmly</p>		
ALL	<p>7 Install ampoule assy on needle assy (push and turn CW)</p> <p style="text-align: center;"><u>CAUTION</u></p> <p>If potable water quantity is <50%, inject half the contents of each ampoule (chlorine and buffer) by rotating knob three turns (CW).</p>		Two turns for half empty if H2O quantity <50%.
	<p>6 Rotate knob ~3-1/2 turns (CW) until ampoule is empty (piston bottoms out)</p>		
	<p>9 Disconnect ampoule assy from needle assy (push & turn CCW)</p>		

POTABLE WATER CHLORINATION

APOLLO-SOYUZ TEST PROJECT (ASTP)
OPERATIONS HANDBOOK

STA/T STEP	PROCEDURE	PANEL	REMARKS
ALL 10	Rotate knob (CCW), remove & stow used ampoule	352	Place used ampoule in chlorination unit stowage bag.
11	Repeat steps 5 through 8 using buffer ampoule		Buffer ampoules color-coded brown.
12	Wait 10 min, remove ampoule of H2O by slowly rotating injector barrel (CCW) three turns while holding bayonet section in locked position (CW).		
13	Rotate knob (CCW), remove & stow used ampoule		
14	Stow chlorination unit		
15	Replace chlorination port cap		
	<u>CAUTION</u>		
	Wait 30 min before withdrawing water for drinking or food preparation.		
5.4.6	<u>PGA Mode Changes</u>		
a.	PGA to Shirtsleeve		
CP	CAB PRESS ind -> 4.7 psia (verify)	2	Two flow paths exist for returning cabin atmosphere to suit circuit for scrubbing.
ALL	EMER CAB PRESS sel - BOTH Doff and stow gloves & helmet	351	

5.4.6

PGA MODE CHANGES

NORMAL/BACKUP

APOLLO-SOYUZ TEST PROJECT (ASTP)
OPERATIONS HANDBOOK

STA/T STEP	PROCEDURE	PANEL	REMARKS
AC ALL	<p>If suit return vlv is used SUIT RETURN vlv - OPEN PULL Retrieve inflight coveralls SUIT PWR - OFF PWR - OFF AUDIO CONT - NORM</p> <p style="text-align: center;"><u>WARNING</u></p> <p>If comm umbilical is to be disconnected at bulkhead or control head, VHF AM sw on associated panel must be placed OFF & S BD MODE PCM sw must be in PCM or ctr.</p>	380 9,10,6	
AC	<p>Disconnect O2 & comm umbilicals at PGA & insert interconnect in O2 return hose</p> <p>If suit return vlv is <u>not</u> used Retrieve inflight coveralls SUIT PWR - OFF PWR - OFF AUDIO CONT - NORM DEMAND REG sel - OFF</p> <p style="text-align: center;"><u>WARNING</u></p> <p>If comm umbilical is to be disconnected at bulkhead or control head, VHF AM sw on associated panel must be placed OFF & S BD MODE PCM sw must be in PCM or ctr.</p>	380	Screens plus hose causes increased pressure drop in suit circuit causing O2 demand flow.

PGA MODE CHANGES

APOLLO-SOYUZ TEST PROJECT (ASTP)
OPERATIONS HANDBOOK

STA/T STEP	PROCEDURE	PANEL	REMARKS
ALL	Disconnect O2 & comm umbilicals at PGA & install suit return hose screen cap		Suit donning and suit loop isolation requires additional time for repositioning suit flow valves (inaccessible from couches) in addition to normal suiting time.
CP	SUIT FLOW vlv - CAB FLOW (for unsuited crewmen)	300, 301, 302	Adjust suit flow valve between CAB FLOW and FULL FLOW to maintain adequate flow for suited crewmar.
ALL	Disconnect UTCA, comm & biomed connectors Doff & stow UTCA & PGA Don inflight coveralls Retrieve & connect CWG adapter to comm & biomed connectors Audio panel sw (all) - as desired	9, 10, 6	Comm and biomed integrity should be verified.
b.	Shirtsleeve to PGA SUIT PWR - OFF PWR - OFF AUDIO CONT - NORM		Two flow paths exist for returning cabin atmosphere to suit circuit for scrubbing.
	<u>WARNING</u> If comm umbilical is to be disconnected at bulkhead or control head, VHF AM sw on associated panel must be placed OFF & S BD MODE PCM sw must be in PCM or ctr.		

5.4.6
PGA MODE CHANGES

NORMAL/BACKUP

APOLLO-SOYUZ TEST PROJECT (ASTP)
OPERATIONS HANDBOOK

STA/T STEP	PROCEDURE	PANEL	REMARKS
ALL	Disconnect & stow CWG adapter Doff & stow inflight coveralls Retrieve & don UTCA & PGA, connecting UTCA, comm & biomed connectors If suit return vlv is used Remove O2 umbilical interconnect & connect O2 & comm umbilicals to PGA		Connect blue to blue and red to red.
AC	SUIT RETURN vlv - CLOSE PUSH (if all suited) Remove suit circuit return hose screen cap & connect O2 & comm umbilicals	380	Connect blue to blue and red to red. Suit donning and suit loop isolation requires additional time for repositioning suit flow valves (inaccessible from couches) in addition to normal suiting time.
ALL	DEMAND REG sel - BOTH SUIT FLOW vlv - FULL FLOW (for suited crewman) Audio panel sw (all) - as desired	380 300,301,302 9,10,6	Comm and biomed integrity should be verified.
CP	Retrieve & don helmet & gloves EMER CAB PRESS sel - OFF (if all suited)	351	
ALL	c. PGA to Partial PGA CAB PRESS ind - >4.7 psia (verify) EMER CAB PRESS sel - BOTH Doff & stow gloves & helmet	2	Two flow paths exist for returning cabin atmosphere to suit circuit for scrubbing.

PGA MODE CHANGES

APOLLO-SOYUZ TEST PROJECT (ASTP)
OPERATIONS HANDBOOK

STA/T STEP	PROCEDURE	PANEL	REMARKS
AC ALL	If suit return vlv is used SUIT RETURN vlv - OPEN PULL Reverse O2 umbilical connections at PGA Supply hose to outlet connector Return hose to inlet connector If suit return vlv is not used DEMAND REG sel - OFF	380	O2 umbilicals reversed for optimum flow distribution within PGA.
AC	Disconnect return hose from PGA & install suit return hose screen cap Connect supply hose to outlet connector		Screens plus hose cause increased pressure drop in suit circuit causing O2 demand flow.
ALL	<p>5.4.7 <u>Waste Management Procedures</u></p> <p><u>WARNING</u></p> If germicide pouch is accidentally ruptured, proceed as follows: <ul style="list-style-type: none"> • Germicide on CM surface or hardware; wipe up with tissue. • Germicide on crewman's skin; blot with tissue and flush with water. • Germicide in crewman's eyes; irrigate with water from water gun or soaked tissue. 		

5.4.7

WASTE MANAGEMENT PROCEDURES

NORMAL/BACKUP

APOLLO-SOYUZ TEST PROJECT (ASTP)
OPERATIONS HANDBOOK

STA/T STEP	PROCEDURE	PANEL	REMARKS
<p>● Germicide ingested; take magnesium compound and/or high protein food - do not induce vomiting.</p> <p>a. Urine Dump Modes</p>	<p>(1) PGA urine collection (UCTA) bag</p> <p>Connect urine line filter to urine trnfr hose</p> <p>Connect urine trnfr nose/filter to urine/overboard QD</p> <p>Remove cap from PGA thigh QD and stow</p> <p>Connect urine trnfr hose T QD to thigh QD</p> <p>OVBD DRAIN vlv - DUMP</p> <p>When PGA bag (UCTA) empty, disconnect urine trnfr hose T QD at PGA thigh QD</p> <p>Replace cap on PGA thigh QD</p> <p>Connect adapter to urine trnfr hose (tethered to hose)</p> <p>Connect UTS to urine trnfr hose/filter QD</p> <p>UTS vlv - open</p> <p>Purge until particles cease exhausting vent line (2 to 5 min), then OVBD DRAIN vlv - OFF</p>	<p>251</p>	<p>For stowage, reference NASA document (TBD).</p> <p>Temporary stowage.</p> <p>View urine expulsion from dump nozzle through left window No. 1.</p>

WASTE MANAGEMENT PROCEDURES

APOLLO-SOYUZ TEST PROJECT (ASTP)
OPERATIONS HANDBOOK

STA/T STEP	PROCEDURE	PANEL	REMARKS
ALL	<p>UTS vlv - close Disconnect UTS from urine trnfr hose and stow Disconnect urine trnfr hose from urine/overboard QD and stow</p> <p>(2) UTS (collection)</p> <p>Obtain UTS and verify vlv closed Roll cuff - affixed UTS vlv - open Perform task</p> <p>UTS vlv - close Roll cuff - removed Free urine in cuff absorbed with tissue UTS - stow (temporary) When convenient, dump urine by UTS (dump) procedure</p> <p>(3) UTS (dump) Connect urine line filter to urine trnfr hose (verify) Connect urine trnfr hose/filter to urine/overboard QD Connect adapter to urine trnfr hose (tethered to hose)</p>	251	<p>For stowage, reference NASA document (TBD).</p> <p>Used when inconvenient for simultaneous urination and overboard dumping.</p> <p>Six spare roll-on cuffs stowed in medical accessory kit and one spare receiver assembly provided.</p>

5.4.7

WASTE MANAGEMENT PROCEDURES

NORMAL/BACKUP

APOLLO-SOYUZ TEST PROJECT (ASTP)
OPERATIONS HANDBOOK

STA/T STEP	PROCEDURE	PANEL	REMARKS
ALL	<p>Obtain UTS and verify vlv closed Attach UTS to urine trnfr hose/adaptor QD Perform UTS (collection) (if req), 5.4.7a (2) OVBD DRAIN vlv - DUMP When UTS bag empty, UTS vlv - open Purge 2-5 min, then OVBD DRAIN vlv - OFF UTS vlv - close Disconnect UTS from urine trnfr hose/adaptor and stow Disconnect urine trnfr hose from urine/overboard QD and stow</p>	251	For storage, reference NASA document (TBD).
	<p>(4) Urine Receptacle Assy (URA) Connect urine line filter to urine trnfr hose Connect urine trnfr hose/filter to urine/overboard QD Connect urine receptacle to urine trnfr hose URA vlv - VENT Remove receptacle cover OVBD DRAIN vlv - DUMP Perform task</p>		GFE assembly.
			Direct urine stream parallel to honeycomb to prevent splashback. Avoid accelerations to URA during use. Remove last drop by touching screen at top of URA.

WASTE MANAGEMENT PROCEDURES

APOLLO-SOYUZ TEST PROJECT (ASTP)
OPERATIONS HANDBOOK

STA/T STEP	PROCEDURE	PANEL	REMARKS
ALL	<p>Flush screen & honeycomb with water gun (10 sec max)</p> <p>Replace receptacle cover after liquid has cleared from URA</p> <p>URA vlv - VENT (verify) and purge URA for 2-5 min</p> <p>URA vlv - CLOSE (CW)</p> <p>Stow URA for next use with urine trnfr hose conn & OVBD</p> <p>DRAIN vlv - DUMP (verify)</p> <p>For stowage prior to entry</p> <p>OVBD DRAIN vlv - OFF</p> <p>Remove & stow URA, urine trnfr hose & urine filter</p> <p>b. Defecation</p> <p>Remove fecal collection assy from stowage</p> <p>Obtain defecation collection device from assy</p> <p>Remove germicide pouch</p> <p>Insert germicide pouch (protective cover removed) into inner fecal bag</p> <p>Remove protective covering from lip of inner fecal bag & place into bag</p> <p>Affix inner fecal bag</p> <p>Perform task</p> <p>Seal inner fecal bag</p> <p>Rupture germicide pouch</p>	251	<p>Allows URA to vacuum dry between uses.</p> <p>For stowage, reference NASA document (TBD).</p> <p>Lip of inner fecal bag covered with adhesive.</p> <p>Remove air prior to sealing.</p>

5.4.7

WASTE MANAGEMENT PROCEDURES

NORMAL/BACKUP

APOLLO-SOYUZ TEST PROJECT (ASTP)
OPERATIONS HANDBOOK

STA/T STEP	PROCEDURE	PANEL	REMARKS
ALL	<p>Knead contents for 4 min Insert into outer fecal bag Only subsequent to initial odor detection will waste stowage container be vented prior to each waste deposit WASTE STOW VENT vlv - VENT for 30 sec, then CLOSE Stow fecal bag</p>	252	Fecal matter stowed in waste stowage container.
c.	<p>Emesis Obtain fecal/emesis (F/E) bag Perform task Insert germicide pouch (protective cover removed) into inner F/E bag Seal inner F/E bag Rupture germicide pouch Insert inner F/E bag into outer F/E bag & seal Only subsequent to initial odor detection will waste stowage container be vented prior to each waste deposit WASTE STOW VENT vlv - VENT for 30 sec, then CLOSE Stow outer F/E bag</p>		For storage, reference NASA document (TBD).
CP	<p>Side Hatch Urine/Water Dump Remove dump nozzle conn cover and withdraw wires, wire guard, and heater conn from cover</p>	Side hatch	Use tool E. Rotate cover as necessary to permit removal of electrical heater connector. Connector lock pins must be aligned with slots (3) in threaded portion of cover.

WASTE MANAGEMENT PROCEDURES

APOLLO-SOYUZ TEST PROJECT (ASTP)
OPERATIONS HANDBOOK

STA/T STEP	PROCEDURE	PANEL	REMARKS
CP	Remove plug and stow Install cable tether retaining ring over aux dump nozzle QD threads Install male QD on dump nozzle (finger tight) Connect cable to htr conn (if req)	Side	Use tool E. For stowage, reference NASA document (TBD). The side hatch dump nozzle heater need not be connected (crew option). CM orientation and previous cold soak should be considered when electing not to connect heater. If nozzle freezes, connect and use heater to thaw nozzle.
	UTIL PWR - OFF (verify) Connect cable to utility outlet UTIL PWR - ON (up)	16	
	If urine overboard dump req Connect urine dump hose to dump nozzle QD	Side hatch	Cabin to ambient AP will provide for urine flow.
	If waste H2O overboard dump req WASTE TK SERV vlv - CLOSE (verify)	352	
	Remove conn cap on waste tank servicing conn Install female QD on waste tank servicing conn		Use tool L.
	Connect urine dump hose tee-adaptor to waste tank servicing conn QD and to dump nozzle QD		
DP	H2O QTY IND sw - WASTE	2	
CP	WASTE TK SERV vlv - OPEN until WASTE H2O QTY ind \approx 15%, then CLOSE	352	

5.4.7 WASTE MANAGEMENT PROCEDURES

NORMAL/BACKUP

APOLLO-SOYUZ TEST PROJECT (ASTP)
OPERATIONS HANDBOOK

STA/T STEP	PROCEDURE	PANEL	REMARKS
CP	<p>If req to dump to 0% POT TK IN vlv - OPEN WASTE TK IN vlv - AUTO (verify) Disconnect urine dump hose tee-adapter from waste tank servicing conn QD Disconnect tee-adapter from urine dump hose and purge (30 sec min) Disconnect urine dump hose from dump nozzle QD and stow Reconnect tee-adapter UTIL PWR - OFF (verify) Disconnect heater cable from dump nozzle heater conn and to utility outlet (verify) Remove dump nozzle QD and stow Stow heater cable (verify) Install plug and dump nozzle conn cover</p>	<p>352 Side hatch 16 Side hatch</p>	<p>A dump to zero could expose the suit heat exchanger to adverse pressure conditions if the POT TK IN vlv and the WASTE TK IN vlv are not configured properly.</p> <p>The tee-adapter is tethered to the urine dump hose. This will provide overboard vent to purge urine dump hose.</p>
e.	<p>Water Collection Conn urine trnfr hose-filter to urine/overboard QD Conn cab purge QD to urine trnfr hose OVBD DRAIN vlv - DUMP Collect water After collection is complete Purge until particles cease exhausting vent line (1 to 2 min) OVBD DRAIN vlv - OFF</p>	<p>251</p>	<p>Use tool E.</p>

WASTE MANAGEMENT PROCEDURES

ALOULO-SOYUZ TEST PROJECT (ASTP)
OPERATIONS HANDBOOK

STA/T STEP	PROCEDURE	PANEL	REMARKS
f.	Vac Oper Using O2 Umb <u>CAUTION</u> Not to be used for H2O collection. Ingestion of H2O will cause swelling of CO2 cstr element.		
AC	DEMAND REG sel - OFF	380	Screens plus hose cause increased pressure drop in suit circuit causing O2 demand flow.
ALL	SUIT RETURN vlv - close (push) Install one interconnect to two return hoses Use third return hose SUIT FLOW vlv (3) - FULL FLOW	300,301,302	
AC	At completion of vac SUIT RETURN vlv - open (pull)	380	
ALL	DEMAND REG sel - BOTH SUIT FLOW vlv (3) - CAB FLOW	300,301,302	
DP	Remove interconnect & install screen cap on return hose		
5.4.8	<u>CM Repressurization</u>		
a.	Normal Mode (time ~30 min)	325	
AC	CAB PRESS RELF vlv (2) - NORM (safety latch on)		
CP	CAB PRESS DUMP vlv - close (CW) (verify)	Side hatch	
	O2 PRESS IND sw - SURGE TK	2	

5.4.8

CM REPRESSURIZATION

NORMAL/BACKUP

APOLLO-SOYUZ TEST PROJECT (ASTP)
OPERATIONS HANDBOOK

STA/T STEP	PROCEDURE	PANEL	REMARKS
AC	REPRESS PKG vlv - FILL	326	Guarded. Minimum surge tank pressure.
CP	REPRESS O2 - OPEN CRYO O2 PRESS 1 ind - 150 psia min	601 2	
AC	REPRESS PKG vlv - OFF	326	Guarded. Maintain 150 psia minimum in surge tank.
CP	CAB PRESS ind - 3.0 psia (in 1 min)	2	
AC	REPRESS O2 PRESS ind - 0.0 psig	602	Guarded. Maintain 150 psia minimum in surge tank.
CP	REPRESS O2 - CLOSE CAB PRESS vlv - open (CW)	601 351 2	
	CAB PRESS ind - 4.7-5.3 psia		
	O2 PRESS IND sw - TK 1 CAB PRESS vlv - OFF (CCW)	351	
AC	b. Alternate Mode (time 5:2 min)	325	Minimum surge tank pressure.
CP	CAB PRESS RELF vlv (2) - NORM (safety latch on)	Side hatch	
	CAB PRESS DUMP vlv - close (CW) (verify)	351	
	EMER CAB PRESS sel - BOTH	2	
	CAB PRESS vlv - OPEN (CW)		
	O2 PRESS IND sw - SURGE TK		
	CRYO O2 PRESS 1 ind - 150 psia min		
	EMER CAB PRESS sel - OFF	351	
	CAB PRESS vlv - adjust to 150 psia min		
	CAB PRESS ind - 4.7-5.3 psia	2	
	O2 PRESS IND sw - TK 1 CAB PRESS vlv - OFF (CCW)	351	

CM REPRESSURIZATION

APOLLO-SOYUZ TEST PROJECT (ASTP)
OPERATIONS HANDBOOK

STA/T STEP	PROCEDURE	PANEL	REMARKS
5.4.9	<p><u>Pressure Suit Circuit & PGA Check at 5.0 Psia</u></p> <p>Configure Suit Loop Crew members suited & umbilical connected SUIT FLOW vlv not used by crewman - OFF, or PGA O2 umbilical couplings installed</p> <p>a. Gross Suit Circuit Verification</p> <p>DIRECT O2 vlv - close (CW) SUIT PRESS ind - 4.7-5.3 psia O2 FLOW ind - 0.2-0.4 lb/hr</p> <p style="text-align: center;"><u>CAUTION</u></p> <ul style="list-style-type: none"> • SUIT TEST vlv should remain IN PRESS position until suit circuit pressure is stabilized to preclude seal scarring. • If repositioning of SUIT TEST vlv from PRESS is required prior to suit pressure stabilization, perform the following: <ol style="list-style-type: none"> a. DEMAND REG sel - OFF 380 b. Allow 15 sec (min) stabilization time c. Reposition SUIT TEST vlv - DEPRESS or OFF as applicable d. When suit pressure stabilized, DEMAND REG sel - BOTH 	<p>7 2</p>	<p>PGA O2 umbilical couplings (3) are plugged.</p> <p>This procedure may be used in lieu of step b, PGA Check Only, to ascertain complete suit loop integrity.</p>

5.4.9

PRESSURE SUIT CIRCUIT & PGA CHECK AT 5.0 PSIA

NORMAL BACKUP

MIOLLO-SOYUZ TEST PROJECT (ASTP)
OPERATIONS HANDBOOK

STA/T STEP	PROCEDURE	PANEL	REMARKS
AC	SUIT TEST vlv - PRESS	380	All crewmen exercise PGA joints during pressurization period. DIRECT O2 valve may be slightly opened to reduce suit loop pressurization time, but must be fully closed (CW) at 4.0 psid suit pressure.
CP	O2 FLOW ind - 1.0 lb/hr (pegged)	2	After 16-second delay.
ALL	O2 FLOW HI lt - on MASTER ALARM pb/lt (3) - on, 1,3,122 push		
AC	Cycle SUIT RETURN vlv - OPEN PULL & CLOSE PUSH when SUIT PRESS ind - 1.5-2.0 psia > cabin press	380 2	Continue suit circuit pressurization until O2 flow starts to decrease.
CP	SUIT PRESS ind - 8.8-9.8 psia		Crewmen remain inactive while monitoring suit circuit pressure and O2 flow indicator to preclude fluctuations in O2 flow. Monitoring should not be scheduled during H2O accumulator stroking (or 30 seconds thereafter), or accumulators should be temporarily disabled during test (SUIT H2O ACCUM AUTO - ctr, then back to previous position).
ALL	PGA press ind (3) - 4.1-4.5 psid	PGA	
CP	O2 FLOW HI lt - out O2 FLOW ind - stabilize for 15 sec, & remain <0.8 lb/hr for 30 sec after stabilization	2	
AC	SUIT TEST vlv - DEPRESS	380	
CP	O2 FLOW ind - 0.2-0.4 lb/hr SUIT PRESS ind - slightly > CAB PRESS ind	2	In ≈ 75 seconds.
AC	SUIT TEST vlv - OFF DEMAND REG sel - BOTH (verify)	380	

PRESSURE SUIT CIRCUIT & PGA CHECK AT 5.0 PSIA

APOLLO-COYUZ TEST PROJECT (ASTP)
OPERATIONS HANDBOOK

STA/T STEP	PROCEDURE	PANEL	REMARKS
AC CP	<p>b. PGA Check Only</p> <p>DIRECT O2 vlv - close (CW) SUIT PRESS ind - 4.7-5.3 psia O2 FLOW ind - 0.2-0.4 lb/hr</p> <p><u>CAUTION</u></p> <p>SUIT TEST vlv should remain in PRESS position until suit circuit pressure is stabilized to preclude seal scarring.</p>	7 2	<p>This procedure performed only if individual or collective PGA verification required.</p>
AC	<p>SUIT TEST vlv - PRESS</p>	380	<p>All crewmen exercise PGA joints during pressurization period. DIRECT O2 valve may be slightly opened to reduce suit loop pressurization time, but must be fully closed (CW) at 4.0 psig suit pressure.</p>
CP ALL	<p>O2 FLOW ind - 1.0 lb/hr (pegged) O2 FLOW HI lt - on MASTER ALARM pb/lt (3) - on, 1,3,122 push</p>	2	
CP ALL	<p>SUIT PRESS ind - 8.8-9.8 psia PGA press ind (3) - 4.1-4.5 psid</p> <p><u>WARNING</u></p> <p>Suit flow vlv(s) may remain in OFF position for no longer than one min or asphyxiation may result.</p>	2 PGA	<p>After ~75 seconds.</p>

5.4.9 PRESSURE SUIT CIRCUIT & PGA CHECK AT 5.0 PSIA

NORMAL/BACKUP

APOLLO-SOYUZ TEST PROJECT (ASTP)
OPERATIONS HANDBOOK

STA/T STEP	PROCEDURE	PANEL	REMARKS
	<p align="center"><u>CAUTION</u></p> <p>If all suit flow vlvs are closed simultaneously, the suit compressors must be shut off to prevent compressor damage because of deadheading of suit loop.</p>		
CP	<p>SUIT FLOW vlv (suited crewmen) - OFF 300,301,302</p> <p>PGA press ind (suited crewmen) - PGA <0.5 psid/min pressure decay</p>		<p>Crewmen hold breath and remain inactive while monitoring PGA pressure decay to preclude pressure drop or fluctuation on PGA pressure indicators.</p>
AC	<p align="center"><u>CAUTION</u></p> <p>If repositioning of SUIT TEST vlv from PRESS is required prior to suit pressure stabilization, perform the following:</p> <ol style="list-style-type: none"> DEMAND REG sel - OFF Allow 15 sec (min) stabilization time Reposition SUIT TEST vlv - DEPRESS or OFF as applicable When suit pressure stabilized, DEMAND REG sel - BOTH 	380	

PRESSURE SUIT CIRCUIT & PGA CHECK AT 5.0 PSIA

APOLLO-SOYUZ TEST PROJECT (ACTP)
OPERATIONS HANDBOOK

STA/T STEP	PROCEDURE	PANEL	REMARKS
AC CP	SUIT TEST vlv - DEPRESS O2 FLOW HI lt - out O2 FLOW ind - 0.2-0.4 lb/hr SUIT PRESS ind - slightly >CAB PRESS ind	380 2	In ~75 seconds.
AC	SUIT TEST vlv - OFF	380	
5.4.10	<u>CM O2 Supply Refill</u>		
CP	O2 PRESS IND sw - SURGE TK CRYO O2 PRESS 1 ind - >400 psia	2	After cabin repressurization, 400 psia is minimum surge tank pressure that will assure an O2 system equilibrium pressure >150 psia at initiation of refill operation.
AC	CAB REPRESS vlv - OFF (CCW) REPRESS O2 - CLOSE REPRESS PKG vlv - FILL	351 601 326	Guarded.
CP	CRYO O2 PRESS 1 ind - 865-935 psia O2 PRESS IND sw - TK 1	2	Monitor pressure to ensure no decrease below 150 psia. Upon completing refill operation.
AC	REPRESS PKG vlv - OFF	326	
5.4.11	<u>CM Pressure Dump</u>		
CP	a. Using Cab Press Relf Vlv	2	
AC	CAB FANS - OFF (verify) DIRECT O2 vlv - close (CW) rh CAB PRESS RELF vlv - DUMP (safety latch off)	7 325	Valve in DUMP position long enough for cabin pressure to decrease to ~3.25 psia. O2 FLOW HI light may come on prior to cabin pressure regulator lockup.
CP	CAB PRESS ind - 3.0-3.25 psia	2	
AC	rh CAB PRESS RELF vlv - BOOST/ENTR	325	
CP	O2 FLOW ind - ~0.24 lb/hr	2	Verifies cabin pressure regulator lockout.

5.4.11

CM PRESSURE DUMP

NORMAL/BACKUP

APOLLO-SOYUZ TEST PROJECT (ASTP)
OPERATIONS HANDBOOK

STA/T STEP	PROCEDURE	PANEL	REMARKS
AC	SUIT PRESS ind - 3.5-4.0 psia	2	Verifies suit demand pressure regulator aneroid function.
AC	rh CAB PRESS RELF vlv - DUMP	325	
AC	CAB PRESS ind - 0.0 psia (within 6 min)	2	Cabin at 0.01 psia within 4.5 minutes.
AC	CAB PRESS RELF vlv (2) - NORM (safety latch on)	325	
DP	b. Using Side Hatch Cab Press Dump Vlv		
CP	CAB FANS - OFF (verify)	2	
AC	EMER CAB PRESS sel - OFF	351	
AC	REPRESS PKG vlv - OFF	326	
	If lone crewman oper REPRESS PKG vlv - FILL		REPRESS PKG valve should be in FILL position for lone crewman activities, as leaving valve in OFF reduces immediate repressurization capability to ~1.8 psia, less than amount required to sustain life if suit ruptures.
DP	REPRESS O2 vlv - CLOSE	601	
AC	CAB PRESS RELF vlv (2) - NORM (safety latch on)	325	
	DIRECT O2 vlv - close (CW) (verify)	7	
DP	CAB PRESS DUMP vlv - open (CCW - one turn)	Side hatch	Valve in open position long enough for cabin pressure to decrease to ~3.25 psia. O2 FLOW HI light may come on prior to cabin pressure regulator lockup.
	CAB PRESS ind - 3.0-3.25 psia	2	
	CAB PRESS DUMP vlv - close (CW)	Side hatch	
	O2 FLOW ind - <0.5 lb/hr	2	Verifies cabin pressure regulator lockout and that EMER CAB PRESS selector is OFF.

CM PRESSURE DUMP

APOLLO-SOYUZ TEST PROJECT (ASTP)
OPERATIONS HANDBOOK

STA/T STEP	PROCEDURE	PANEL	REMARKS
CP	SUIT PRESS ind - 3.5-4.0 psia CAB PRESS DUMP vlv - open (CCW) CAB PRESS ind - 30 psia CAB PRESS DUMP vlv - close (CW)	2 Side hatch 2 Side hatch	Verifies suit demand pressure regulator aneroid function. Full open.
5.4.12	<u>Suit Circuit Purge of H2</u>		
AC	DIRECT O2 vlv - OPEN (CCW) for 1 min	7	Suit circuit pressure relief valve dumps hydrogen into cabin.
CP	O2 FLOW ind - 1.0 lb/hr (pegged) O2 FLOW HI lt - on	2	After 16-second time delay.
ALL	MASTER ALARM pb/lt (3) - on, push	1,3,122	
AC	DIRECT O2 vlv - close (CW)	7	
CP	O2 FLOW HI lt - out O2 FLOW ind - 0.2 lb/hr (pegged)	2	
5.4.13	<u>Cabin Cold-Soak Operation</u>		
CP	a. Activate Cold Soak Open cool control atten pnl		Secondary glycol loop placed in evaporative cooling mode, and routed only to suit circuit heat exchanger. Covers panel 382.
	<u>WARNING</u> SUIT FLOW RELF vlv must remain OFF throughout mission or swelling of CO2 odor absorber filters may result.	382	

5.4.13 CABIN COLD-SOAK OPERATION

NORMAL/BACKUP

APOLLO-SOYUZ TEST PROJECT (ASTP)
OPERATIONS HANDBOOK

STA/T STEP	PROCEDURE	PANEL	REMARKS
CP	SUIT HT EXCH SEC GLY - FLOW SEC EVAP H2O CONT vlv - AUTO Close cool control atten pnl CAB TEMP - MAN	382 2	Maximum cold position. Bypass cabin heat exchanger.
CP	PRIM CAB TEMP vlv - COLD (CW) SEC CAB TEMP vlv - OFF (CCW)	303	
DP	ECS IND sel - SEC SEC COOL PUMP - AC2 SEC GLY DISCH PRESS ind - 39-52 psia SEC ACCUM QTY ind - 30-60% SEC COOL EVAP - EVAP SEC GLY EVAP OUT TEMP ind - 38°-50.5°F SEC GLY EVAP STM PRESS ind When boiling - 0.09-0.14 psia Not boiling - >0.14 psia ECS IND sel - PRIM RAD PRIM OUT TEMP ind - >-20°F If <-20°F SEC COOL EVAP - RSET for 58 sec min, then off (ctr) SEC COOL PUMP - off (ctr)	2	After initiating cold-soak operation, periodic ECS monitoring check should include readings from the following secondary loop indicators: SEC GLY EVAP OUT TEMP, SEC GLY EVAP STM PRESS, SEC GLY DISCH PRESS, and SEC ACCUM QTY. Cold soak operation is stopped until RAD PRIM OUT TEMP indicator - >0°F.
CP	b. Deactivate Cold Soak SEC CAB TEMP vlv - MAX COOL (CW)	303	
DP	CAB TEMP - AUTO SEC COOL EVAP - RSET for 58 sec min, then off (ctr)	2	RSET closes steam pressure control valve. Steam pressure valve requires 58 seconds from full open to full close.

CABIN COLD-SOAK OPERATION

APOLLO-SOYUZ TEST PROJECT (ASTP)
OPERATIONS HANDBOOK

STA/T STEP	PROCEDURE	PANEL	REMARKS
CP	SEC COOL PUMP - off (ctr) Open cool control atten pnl	2	
	<u>WARNING</u> SUIT FLOW RELF vlv must remain OFF throughout mission or swelling of CO2 odor absorber filters may result. SEC EVAP H2O CONT vlv - OFF Close cool control atten pnl	382	Valve should be left at AUTO for cold soak deactivation prior to entry.
	<u>5.4.14 Operation of Emergency O2 Masks</u> EMER O2 - OPEN	600	Masks stowed on aft bulkhead aft of emergency O2 unit.
ALL	Don emer O2 masks	AESB	Push mask pushbutton for continuous flow, otherwise mask is demand flow.
CP	Doff emer O2 masks EMER O2 - CLOSE	600	
	<u>5.4.15 Waste Water Tank Drain</u> BAT VENT vlv - CLOSE H2O QTY IND sw - WASTE PRESS RELF sel - DUMP A Monitor WASTE H2O QTY ind - decr (5% per min) WASTE H2O QTY ind - ~15%	252 2 352 2	

WASTE WATER TANK DRAIN

5.4.15

NORMAL/BACKUP

APOLLO-SOYUZ TEST PROJECT (ASTP)
OPERATIONS HANDBOOK

STA/T STEP	PROCEDURE	PANEL	REMARKS
CP	If req to dump to O/S	2	A dump to zero could expose the suit heat exchanger to adverse pressure conditions if the WASTE TK IN vlv is not configured properly.
	POT TK IN vlv - OPEN (verify) WASTE TK IN vlv - AUTO (verify)	352	
	PRESS RELF sel - 2 BAT VENT vlv - VENT	252	
	5.4.16 <u>Gas Separator Cartridge Servicing</u>		
	a. Remove separator cartridges from stowage		
	b. Attach separator to water pistol		
	c. Trigger water pistol in short pulses until water is observed at separator outlet port		
	d. Wait 10 min		
	<u>CAUTION</u> Membrane can be damaged by pencils, screwdrivers, & other pointed objects.		
	e. Use separator on water pistol or food prep unit as req		

Female port of separator will fit on water pistol probe.

Allow 10 minutes for membrane wetting.

GAS SEPARATOR CARTRIDGE SERVICING

APOLLO-SOYUZ TEST PROJECT (ASTP)
OPERATIONS HANDBOOK

STA/T STEP	PROCEDURE	PANEL	REMARKS
5.4.17	<u>Primary Glycol Evaporator Operation</u>		
1	Activate prim evap GLY EVAP H2O FLOW - AUTO GLY EVAP STM AUTO - AUTO	2	
2	Deactivate prim evap GLY EVAP H2O FLOW - off (ctr) GLY EVAP STM AUTO - MAN GLY EVAP STM INCR - INCR for 58 sec		INCR position is momentary. Steam pressure valve requires 58 seconds from full open to full close. Procedure to be performed just prior to each rest period following completion of eating and overboard dumps.
5.4.18	<u>Cabin Leak Check</u>		
1	OVED DRAIN vlv - OFF WASTE STOW VENT vlv - CLOSE (verify) CAB PRESS RELF vlv (2) - NORM (verify) PRESS EQUAL vlv - CLOSE (verify) Fwd hatch TUNL VENT vlv - DM/CM AP (verify)	251 252 325 12	
2	DIRECT O2 vlv - OPEN (CCW) until CAB PRESS ind - 5.7 psia	7	
3	DIRECT O2 vlv - CLOSE (CW)		Cabin pressure decay data will be monitored by ground crew.

5.4.18

CABIN LEAK CHECK

NORMAL BACKUP

APOLLO-SOYUZ TEST PROJECT (ASTP)
OPERATIONS HANDBOOK

STA/T STEP	PROCEDURE	PANEL	REMARKS
5.4.19	<u>VTR Suit Hose Utilization</u>		
AC	<p>Installation</p> <p>1h SUIT FLOW - FULL FLOW (verify)</p> <p>Remove suit return hose screen cap and stow</p> <p>Install suit hose interconnect on return hose</p> <p>Connect supply hose to ctr fitting on VTR</p> <p>Removal</p> <p>Disconnect suit hose from VTR fitting</p> <p>Remove suit hose interconnect from return hose</p> <p>Install suit return hose screen cap</p>	301	<p>Use LH crewmen umbilical and/or center crewmen's umbilical.</p> <p>Center fitting is the normal use position. Use side fitting also when additional cooling is required.</p>

VTR SUIT HOSE UTILIZATION

5.5 CAUTION AND WARNING SYSTEM

CAUTION

Any or all of the system status lights should not be left illuminated for more than 10 min or overheating of the matrix will occur.

System management procedures for the C&WS consist of the following:

1. A procedure is provided for an operational test of the detection unit, system status lights, and MASTER ALARM pb/lit and tone. Test may be conducted at any time during mission at the discretion of crew.
2. An inhibit function is provided on panel 201 for signals that cannot be inhibited otherwise. Individual switches are provided to inhibit separate signal inputs to each of the C/W lamp indicators. These can be used to extinguish continuously-illuminated C/W lamp indicators, and to retain the C/W function of those with multi inputs by inhibiting the parameter that initially illuminated the indicator.
3. Acknowledgement of a C/W indication is performed by resetting of the master alarm circuit. The procedures apply during prelaunch or any flight phase of the mission. The Acknowledge Mode may be used to prevent excessive on-time of status lights which will become hot to touch if illuminated for more than 10 minutes.
4. A procedure is provided for adjusting and disabling master alarm tone in each headset, at the discretion of crew.
5. Memory function provides an indication of origin of those signals routed through memory.
6. A list is provided showing the C/W light input function, its associated inhibit switch and matrix light, and whether it is retained in memory.
7. A list is provided showing C/W lamps that may illuminate during normal operations.

5.5

CAUTION AND WARNING SYSTEM

NORMAL/BACKUP

ALC-110-BOYUK TEST PROJECT (ASTP)
OPERATIONS HANDBOOK

STA/T STEP	PROCEDURE	PANEL	REMARKS
5.5.1	<u>C&WS Operational Check</u>		
DP	C/W LAMP TEST - 1 (hold)	2	Position 1 is momentary. Lamp test of MASTER ALARM light on panel 122 is accomplished with the 3X COND LAMP - TEST switch on panel 122. Master alarm tone not activated by this test.
AC	MASTER ALARM pb/lt - on	1	Panel 1 master alarm is disabled when C/W NORM switch is in BOOST mode and cannot be tested.
CP	lh C/W lts (18) - on C/W LAMP TEST - 2 (hold)	2	Position 2 is momentary.
AC	MASTER ALARM pb/lt - out	1	All lights may not be out following release of lamp test switch due to pre-existing malfunctions or conditions.
CF	lh C/W lts (18) - out	2	
DP	MASTER ALARM pb/lt - on	3	All lights will not extinguish following release of lamp test switch if there are pre-existing malfunctions or conditions.
CP	rh C/W lts (18) - on C/W LAMP TEST - rel	2	
DP	MASTER ALARM pb/lt - out	3	MASTER alarm tone activated by this test.
CP	rh C/W lts (18) - out	2	Systems 1 and 2 status lights.
ALL	C/W CSM - CM CM RCS lt (both) - on MASTER ALARM lb/lt (3) & tone - on MASTER ALARM pb/lt - push MASTER ALARM lb/lt (3) & tone - out	1,3,122	MASTER ALARM light on panel 1 will not come on if C/W NORM switch is in BOOST position and cannot be used for reset under this condition.

C&WS OPERATIONAL CHECK

AGILLO-SOYUZ TEST PROJECT (ASTP)
OPERATIONS HANDBOOK

STA/T STEP	PROCEDURE	PANEL	REMARKS
CF	C/W CSM - CSM CM RCS lt (both) - out C/W MEMORY - RSET	2	
	5.5.2 <u>Dark Adaptation Adjustment</u> C/W NORM - ACK (at sunset) C/W NORM - NORM (at sunrise)		Use if desired.
	5.5.3 <u>Acknowledge/Reset Master Alarm Indication</u>		
ALL	a. Normal Mode (C/W NORM in NORM) MASTER ALARM pb/lt (3) & tone - on MASTER ALARM pb/lt (3) - push	1,3,122	All MASTER ALARM lights have reset capability. Pushing any light will reset alarm circuit unless C/W NORM switch in BOOST position. In this case, there is no reset capability with MASTER ALARM light on panel 1.
CP	MASTER ALARM pb/lt (3) tone - out Applicable C/W lt - remains on C/W MEMORY - RSET	2	C/W light remains on until malfunction corrected.
	b. Acknowledge Mode (C/W NORM in ACK) MASTER ALARM pb/lt (3) and tone - on	1,3,122	Mode can be used during sleep periods to preclude C/W lite illumination due to a malfunction to retain darkness adaptation.

5.5.3

ACKNOWLEDGE/RESET MASTER ALARM INDICATION

NORMAL/BACKUP

APOLLO-SOYUZ TEST PROJECT (ASTP)
OPERATIONS HANDBOOK

STA/T STEP	PROCEDURE	PANEL	REMARKS
AC,DP ALL CP	<p>MASTER ALARM pb/lt (2) - push and hold</p> <p>MASTER ALARM pb/lt (3) & tone - out</p> <p>Applicable C/W lt - on, for malfunction indication</p> <p>MASTER ALARM pb/lt (2) - rel</p> <p>Applicable C/W lt - out</p>	<p>1,3</p> <p>1,3,122</p> <p>2</p>	<p>MASTER ALARM light on panel 122 does not have capability.</p>
AC,DP CP	<p>If no C/W lt on</p> <p>C/W NORM - NORM</p> <p>C/W MEMORY - RECALL (hold)</p> <p>Any of the following may illuminate:</p> <p>GLYCOL FLOW LOW, CRYO PRESS, FC1, FC2, FC3, O2 TK1 HTR TEMP, O2 TK 2 HTR TEMP</p> <p>Troubleshoot applicable system(s)</p> <p>C/W MEMORY - RSET</p>	<p>1,3</p> <p>2</p>	<p>Light may be recalled by again holding MASTER ALARM light on panel 1 or 3 as long as out of limits condition exists and is not inhibited.</p> <p>Recalls any signals in memory.</p>
5.5.4	<p><u>Master Alarm Tone Headset Control</u></p>		<p>Clears signals from memory and resets memory for subsequent operation.</p>
ALL	<p>a. Headset tone disable PWR (3) - AUDIO</p> <p>b. Permit tone PWR (3) - AUDIO/TONE</p>	<p>9,10,6</p>	<p>Disable function may be selected individually or in any combination.</p>

MASTER ALARM TONE HEADSET CONTROL

APOLLO-SOYUZ TEST PROJECT (ASTP)
OPERATIONS HANDBOOK

STA/T STEP	PROCEDURE	PANEL	REMARKS
ALL	<p>b. Permit tone PWR (3) - AUDIO/TONE</p> <p>c. Tone level adjust Individually vary tone level of each audio center by screwdriver adjustment</p>	<p>9,10,6</p> <p>223</p>	<p>Tool W (ratchet) and tool 2 (screwdriver).</p>
CP	<p>5.5.5 <u>C/W Memory Operation</u></p> <p>C/W PWR - 1 or 2 (verify) C/W MEMORY - RSET</p> <p>To recall associated C/W alarms C/W NORM - NORM C/W MEMORY - RECALL</p> <p>Any number of the following lights will illuminate as C/W MEMORY sw is held in RECALL if inputs have been out of limits since last C/W MEMORY - RSET operation GLYCCL FLOW LO lt CRYO PRESS lt O2 TK 1 HTR TEMP lt O2 TK 2 HTR TEMP lt FC1 lt FC2 lt FC3 lt</p> <p>To clear signals from memory C/W MEMORY - RSET</p>	<p>2</p>	<p>RSET position is momentary. C/W memory - reset enables the memory power supply. C/W light on until C/W memory is reset following selection of power supply 1 or 2.</p> <p>RECALL position is momentary.</p> <p>Extinguishes applicable C/W lights and resets memory to again accept signals.</p>

5.5.5

C/W MEMORY OPERATION

NORMAL/BACKUP

APOLLO-SOYUZ TEST PROJECT (ASTP)
OPERATIONS HANDBOOK

5.5.6 C/W Lights/Inhibit Memory Switch Matrix

The following list defines all CSM C/W light input functions, out-of-limit displays, associated inhibit switches, and C/W matrix lights. Asterisk adjacent to C/W light in last column denotes C/W signal input to memory. Underlined C/W lights have multi inputs, each of which can be inhibited to retain continued use of the C/W light.

System	C/W Function	Out-of-Limit Display		Manual Inhibit			C/W Light (Panel 2)
		Nominal Trigger Values	Indicator	Panel	Switch	Panel	
Misc	C/W Power Fail (CDU or memory power supply)	<+11.7 or >+13.9 vdc < for +12 vdc pwr <-11.7 or >-13.9 vdc for -12 vdc pwr	None	-	None	-	C/W
	Crew Alert	Ground Command (STDN UDL)	None	-	1A	201	CREW ALERT
EPS	Inv 1 Temp High	>190°F	None	-	1B	201	INV 1 TEMP HI
	02 TK1 HTR TEMP HI	>350°F	SYS TEST (10C)	101	1C	201	*02 TK1 HTR TEMP HI
	02 TK2 HTR TEMP HI	>350°F	SYS TEST (11C)	101	1D	201	*02 TK2 HTR TEMP HI
	MNA Undervolt	<25.6 vdc	DC VOLTS	3	MNA RSET - OFF	3	MEN BUS A UV
	MNB Undervolt	<25.6 vdc	DC VOLTS	3	MNB RSET - OFF	3	MEN BUS B UV
	AC Bus 1 Fail	<95 or >130 vac	AC VOLTS	3	AC1 RSET - OFF	3	AC BUS 1
	AC Bus 2 Fail	<95 or >130 vac	AC VOLTS	3	AC2 RSET - OFF	3	AC BUS 2
	AC Bus 1 Overload	3Ø at 27.7 amps for 15+5 sec 1Ø at 11 amps for 5+1 sec	AC VOLTS	3	AC1 RSET - OFF	3	AC BUS 1 OVLD
	AC Bus 2 Overload	3Ø at 27.7 amps for 15+5 sec 1Ø at 11 amps for 5+1 sec	AC VOLTS	3	AC2 RSET - OFF	3	AC BUS 2 OVLD

CAUTION AND WARNING SYSTEM

ALCULO-SOYUZ TEST PROJECT (ASTP)
OPERATIONS HANDBOOK

System	C/W Function	Out-of-Limit Display		Manual Inhibit		C/W Light (Panel 2)	
		Nominal Trigger Values	Indicator	Panel	Switch		Panel
	AC Bus 2 Overload	3ø at 27.7 amps for 15+5 sec 1ø at 11 amps for 5+1 sec	AC VOLTS	3	AC2 RSET - OFF	3	AC BUS 2 OVLD
	SM Power Disconnect	Fwd current 75 amps Rev current 4 amps 1-10 sec	DC AMPS	3	Appropriate SM PWR SOURCE - OFF	3	SM PWR DISC
CRYO	O2 Tank 1 Press	< 800 or > 950 psia	CRYO O2 PRESS 1	2	2A	201	<u>CRYO PRESS</u>
	O2 Tank 2 Press	< 800 or > 950 psia	CRYO O2 PRESS 2	2	2B	201	
	H2 Tank 1 Press	< 200 or > 270 psia	CRYO H2 PRESS 1	2	2C	201	
	H2 Tank 2 Press	< 200 or > 270 psia	CRYO H2 PRESS 2	2	2D	201	
FC	FC 1 Cond Exh Temp	< 150 or > 175°F	FC COND EXH TEMP	3	3A	201	<u>*FC 1</u>
	FC 1 Skin Temp	< 360 or > 475°F	FC SKIN TEMP	3	3B	201	
	FC 1 pH Factor	pH factor > 9	FC pH HI tb	3	3C	201	
	FC 1 REACS vlv closed	H2 and/or O2 vlv closure	FC REAC tb	3	3D	201	
	FC 2 Cond Exh temp	< 150 or > 115°F	FC COND EXH TEMP	3	11A	201	<u>*FC 2</u>
	FC 2 Skin Temp	< 360 or > 475°F	FC SKIN TEMP	3	11B	201	
	FC 2 pH factor	pH factor > 9	FC pH HI tb	3	11C	201	
	FC 2 REACS vlv closed	H2 and/or O2 vlv closure	FC REAC tb	3	11D	201	

CAUTION AND WARNING SYSTEM

5-5.6

NORMAL/BACKUP

APOLLO-SOYUZ TEST PROJECT (ASTP)
OPERATIONS HANDBOOK

STA/T STEP	PROCEDURE		PANEL		REMARKS		
	C/W Function	Out-of-Limit Display	Indicator	Panel	Switch	Panel	C/W Light (Panel 2)
		Nominal Trigger Values					
System	C/W Function		FC COND EXH	3	4A	201	
	FC 3 Cond Exh Temp	< 150 or > 175°F	FC SKIN TEMP	3	4B	201	*FC 3
	FC 3 Skin Temp	< 360 or > 475°F	FC PH HI tb	3	4C	201	
	FC 3 pH factor	pH factor > 9	FC REACS tb	3	4D	201	
	FC 3 REACS vlv closed	H2 and/or O2 vlv closure					
CM RCS	He Manf Press 1	< 260 or > 330 psia	CM RCS 1 He MANF PRESS	2	Always inhibited with C/W CSM - CSM	2	CM RCS 1
	He Manf Press 2	< 260 or > 330 psia	CM RCS 2 He MANF PRESS	2	Always inhibited with C/W CSM - CSM	2	CM RCS 2
SM RCS	SM RCS A Fuel Tk Press	< 145 or > 215 psia	SM RCS A FUEL TK PRESS	2	5A	201	SM RCS A
	SM RCS A Pkg Temp	< 75 or > 205°F	SM RCS A PKG TEMP	2	5B	201	
	SM RCS B Fuel Tk Press	< 145 or > 215 psia	SM RCS B FUEL TK PRESS	2	5C	201	SM RCS B
	SM RCS B Pkg Temp	< 75 or > 205°F	SM RCS B PKG TEMP	2	5D	201	
	SM RCS C Fuel Tk Press	< 145 or > 215 psia	SM RCS C FUEL TK PRESS	2	6A	201	SM RCS C
	SM RCS C Pkg Temp	< 75 or > 205°F	SM RCS C PKG TEMP	2	6B	201	

CAUTION AND WARNING SYSTEM

APOLLO-SOYUZ TEST PROJECT (ASTP)
OPERATIONS HANDBOOK

System	C/W Function	Out-of-Limit Display		Manual Inhibit			C/W Light (Panel 2)
		Nominal Trigger Values	Indicator	Panel	Switch	Panel	
SM RCS (cont)	SM RCS D Fuel Tk Press	<145 or >215 psia	SM RCS D FUEL TK PRESS	2	6C	201	<u>SM RCS D</u>
	SM RCS D Pkg Temp	<75 or >205°F	SM RCS D PKG TEMP	2	6D	201	
	SM RCS PSM 1 Tk Press	>215 psia	SM RCS FUEL TK PRESS	2	7A	201	SM RCS PSM 1
SPS	SPS Oxid Press	<157 or >200 psia	SPS OXID PRESS	3	7C	201	<u>SPS PRESS</u>
	SPS Fuel Press	<157 or >200 psia	SPS FUEL PRESS	3	7D	201	
	Pitch GMBL Dr Fail 1	Overcurrent condition (26 amp for 90 sec)	None	-	8A	201	<u>PITCH GMBL 1</u>
	Pitch GMBL Dr Fail 2	Overcurrent condition (26 amp for 90 sec)	None	-	8B	201	<u>PITCH GMBL 2</u>
	Yaw GMBL Dr Fail 1	Overcurrent condition (26 amp for 90 sec)	None	-	8C	201	<u>YAW GMBL 1</u>
	Yaw GMBL Dr Fail 2	Overcurrent condition (26 amp for 90 sec)	None	-	8D	201	<u>YAW GMBL 2</u>
ECS	CO2 Partial Press	At >7.6 mm Hg	CO2 PP	2	9A	201	CO2 PP HI
	Glycol Flow O2 Flow	<134 lbs/hr (prim sys) >1.0 lb/hr for 16.5 sec	None O2 FLOW	- 2	9R 9C	201 201	*GLY FLOW LO O2 FLOW HI
SCS	Suit Compr ΔP	ΔP at inlet & outlet <0.25 psid	SUIT COMPR ΔP	2	9D	201	SUIT COMPR
	BMAG 1 Temp BMAG 2 Temp	<168 or >172°F <168 or >172°F	None None	- -	10A 10B	201 201	BMAG 1 TEMP BMAG 2 TEMP

CAUTION AND WARNING SYSTEM

5-5.6

NORMAL/BACKUP

APOLLO-SOYUZ TEST PROJECT (ASTP)
OPERATIONS HANDBOOK

System	C/W Function	Out-of-Limit Display		Manual Inhibit			C/W Light (Panel 2)
		Nominal Trigger Values	Indicator	Panel	Switch	Panel	
G&C	CM Computer	<ul style="list-style-type: none"> ● Loss of prime power ● Scaler fail ● Counter fail ● SCADBL - scaler stage >200 pps ● Parity fail ● Interrupt too long or infrequent ● TC trap - too few or too many TC or TCF instructions ● Night watchman ● Voltage fail ● 4 volt - <3.6 or >4.4 vdc ● 14 volt - <12.5 or >16.0 vdc ● 28 volt - >22.6 vdc ● Oscillator stops ● (Deleted) ● IMU fail ● PIPA fail ● CDU fail 	CMC lt RESTART & PNGS lt	122 2&140	10C	201	CMC
	Inertial Subsystem		ISS lt PROG & PNGS lt	122 2&122	10D	201	ISS

CAUTION AND WARNING SYSTEM

APOLLO-SOYUZ TEST PROJECT (ASTP)
OPERATIONS HANDBOOK

STA/T STEP	PROCEDURE	PANEL	REMARKS
5.5.7	<u>Normal Operation C/W Master Alarms</u> The following list denotes those C/W lamps which may illuminate during normal operation. In all cases except SM C/W lights at CM/SM separation, push the MASTER ALARM pb/lt to clear the MASTER ALARM before proceeding to corrective action.		
C/W Lamp (panel 2)	Remarks		Corrective Action
SM PWR DISCONNECT	Occurs momentarily when connecting fuel cell or descent battery to bus.		None
SM RCS A, B, C, & D SPS PRESS	Occurs at CM separation from SM because C/W CSM switch at CSM position.		C/W CSM - CM; MASTER ALARM pb/lt - push
SM RCS A, B, C, & D	Low temperature may illuminate light while on pad. Quad heaters are off at this time. High temperature may illuminate light during: (1) Boost heating, (2) AVs using SM RCS extensively with SIVB attached, or (3) transposition and docking using SM RCS extensively. During phase (1), master alarm on panel 1 inactive. During phases (2) or (3), normal operating ranges on indicators should be utilized.		Use appropriate inhibit switch to avoid nuisance alarms
O2 FLOW HI	Occurs (1) during cabin purge, and (2) if urine dump valve is left open. May occur during urine dump.		(1) C/W INPUT 9C - INHIBIT (panel 201) (2) Close urine dump valve.
CYRC PRESS	Limits may shift under flight conditions and cause low-limit warning during sleep periods.		Use appropriate inhibit switch to avoid nuisance alarms, if desired.
BMAG 1 TEMP BMAG 2 TEMP	Occurs during power up.		BMAG PWR switch (panel 7) should be left in WARMUP until the light extinguished.

5.5.7

NORMAL/BACKUP

ALCANTARA-COYUZ TEST PROJECT (ACTP)
OPERATIONS HANDBOOK

STA/T STEP	PROCEDURE	PANEL	REMARKS
5.6	TELECOMMUNICATIONS		
	<p>The T/C system will be in operation throughout entire mission. The information and procedures included here consist of normal and backup procedures that will be utilized to accomplish mission requirements and satisfy test objectives. Some of these procedures will only be required during tests or contingencies.</p> <p>Most orbital paths will involve passage over several STDN ground stations within acceptable slant ranges for S-band voice and data communications. Equipment necessary for voice communications, PCN, and TLM transmission will be activated and operating at all times. The UDL will also remain activated and capable of receiving up-data when required.</p> <p>Action required of crew for voice communications and transmission of real-time PCN TLM will be to ensure optimum radiation and reception of RF signals, either by maintaining SC attitude such that selected antenna is directed toward STDN station or by changing antennas or antenna attitude with S-band antenna controls. Also, audio control panels (MDC-6, -9, and -10) must be set up in accordance with requirements of individual crewmen for control of voice transmission and reception.</p> <p>The reception of up-data for updating the CTF and receiving real-time commands (PTCs) will require no action on part of crew since the UDL will normally remain activated and will utilize the same antenna as that used for S-band voice and data operations. For updating command module computer, however, up-telemetry switches (panels 2 and 122) must be set to ACPT position.</p> <p>The following procedures are presented with the assumption that appropriate electrical buses are powered and that proper circuit breakers are closed.</p>		
	<p>5.6.1 <u>Basic Switch Configuration</u></p> <p>DP 1 Apply A-C power TELCON GRP 1 - AC1 TELCON GRP 2 - AC2</p>	4	

TELECOMMUNICATIONS

APOLLO-SOYUZ TEST PROJECT (ASTP)
OPERATIONS HANDBOOK

STA/T STFP	PROCEDURE	PANEL	REMARKS
ALL	2 Audio panel (3) MODE (3) - INTERCOM/PTT S BD (3) - T/R S BD VOL tw (3) - as req SUT PWR (3) - OFF AUDIC CONT (3) - NORM PWR (3) - AUDIO/TONE MASTER VOL tw (3) - as req VHF AM (3) - T/R VHF AM VOL tw (3) as req INTERCOM (2) - T/R CM/RMTE INTERCOM - T/R CM/RMTE INTERCOM VOL tw - as req VHF FM/PAD COM (3) - T/R VHF FM/PAD COM VOL tw (3) - as req VHF RNG - NORM PHONE/MIC CONNECT - OFF	9,10,6 9,10 6 9,10,6 9 10	Each crewman's individual audio panel must be acti- vated to enable him to receive or transmit voice signals. T/R position enables voice transmitter and reception over selected audio channel. RCV position permits reception only. Intercomm between CM, DM, and Soyuz.
AC			ICOM position is morentary.
CP	3 Speaker/Icom Box XMIT/ICOM - off (ctr) POWER - ON VOL tw - as req SPKR/HEADSET - SPEAKER	98	Whenever S BD XPNDR switch is positioned from PRIM to SEC or from SEC to PRIM, hesitate momentarily in OFF position to allow relay actuation to follow switch action. S-band phaselock will be lost upon switching to alternate transponder. Phaselock must be re-established.
DP	4 S band norm S BD XPNDR - PRIM	3	

BASIC SWITCH CONFIGURATION

5.6.1

NORMAL/BACKUP

APOLLO-SOYUZ TEST PROJECT (ASTP)
OPERATIONS HANDBOOK

STA/T STEP	PROCEDURE	PANEL	REMARKS
CP	<p>S BD PWP AMPL PRIM - PRIN S BD PWP AMPL HI - HI S BD MODE VOICE - VOICE S BD MODE PCM - PCM S BD MODE RNC - RNC</p> <p>5 S band aux S BD AUX TAPE - ctr S BD AUX TV - ctr</p> <p>6 Up TLM UP TLM DATA - DATA UP TLM CMD - NORV PWR AMPL tb - gray</p> <p>7 S Band antenna S BD ANT OMNI A - B S BD ANT OMNI - RMTE</p> <p>8 VHF AM VHF AM A - SIMPLEX VHF AM B - off (ctr) VHF AM RCY - off (ctr) VHF AM SOLCH tw (2) - noise +1</p> <p>9 VHF BCN - OFF VHF RNC - OFF</p>	3	<p>Gray indicates power applied to S-band power amplifier.</p> <p>In event marginal VHF voice communications experienced and VHF voice communication required, VHF receiver squelch may be disabled by setting appropriate thumb-wheel to 1. This will allow weak-signal reception, but will severely degrade DSE recorded voice.</p>

BASIC SWITCH CONFIGURATION

APOL 9-SCYUZ TEST PROJECT (ASTP)
OPERATIONS HANDBOOK

STA/T STEP	PROCEDURE	PANEL	REMARKS
DP	10 Tape recorder TAPE RCDR PCM - PCM/ANLC TAPE RCDR RCD - RCD TAPE RCDR FWD - FWD TAPE MOTION tb - gray	3	Gray indicates tape in rotator.
	11 Power SCE PWR - NORM FYP PWR - NORM		
	12 TLM inputs PCM BIT RATE - LO		
	13 VHF ANT - SM LEFT		
	14 S BD SOLCH - ENBL		
CP	15 VTR Power up TLM POWER - ON INTRTRV POWER - ON VTR POWER - ON HD WHL DP MOT - ctr TAPE MODE - ctr TAPE DRIVE - ctr TAPE HD CLEAN - NORMAL LAMP TEST - STATUS	400	
	16 TV VIDEO PWR - OFF VIDEO SOURCE - CM VICO TV MODE - PLAYBACK	426	

5.6.1

BASIC SWITCH CONFIGURATION

NORMAL/BACKUP

APOLLO-SOYUZ TEST PROJECT (ASTP)
OPERATIONS HANDBOOK

STA/T STEP	PROCEDURE	PANEL	REMARKS
DM	17 DM & Soyuz TV Power up Prep DM 1 TV STATION POWER - OFF DM 2 TV STATION POWER - OFF CAMR SYNC - CM/DM TV STATION SEL DM/SOYUZ - UP TLM TV STATION SEL DM1/DM2 - UP TLM CAMR SYNC - UP TLM	808	Basic switch configuration provides CSN-STPN voice and CM-recovery voice.
DP	5.6.2 <u>VHF/AM Modes</u> Simplex A Select Basic, 5.6.1 Duplex A Select Basic, except VHF AM A - DUPLEX Simplex B Select Basic, except VHF AM B - SIMPLEX VHF AM A - off (ctr) Duplex B Select Basic, 5.6.1, except VHF AM B - DUPLEX VHF AM A - off (ctr) RCV ONLY A Select Basic except VHF AM RCV - A VHF AM A - off (ctr)	3	Should not be used until after CSN/SIVB separation as STPN transmission on VHF AM B will interfere with booster TN. CM-recovery backup voice. Should not be used until after CSN/SIVB separation as STPN transmission on VHF AM B will interfere with booster TN. Provides capability to monitor recovery VHF voice transmissions.

VHF/AM MODES

APOLLO-SOYUZ TEST PROJECT (ASTP)
OPERATIONS HANDBOOK

STA/T STEP	PROCEDURE	PANEL	REMARKS
5.6.3	<u>VHF/FM Modes</u> VHF FM Simplex Select Basic, 5.6.1	3	
DP	VHF FM/AM Duplex	3	
ALL	VHF AM (3) - RCV VHF FN/PAD COMM VOL tw - full decr	6,9,10	
5.6.4	<u>VHF AM Ranging Mode</u> VHF AM A - off (ctr) VHF AM B - DUPLEX VHF RNG - on (up) If P20 operating VHF AM mp option selected TRACKER lt - on	2,140	CMC will activate TRACKER light and wait for a "data good" signal from digital ranging generator.
CP		2,140	
AC	ENS - VHF RNG ENS MODE - VHF RNG ENS FUNC - VHF RNG <u>CAUTION</u> There must be no VHF AM voice transmission by CSN or STDN for ~12 sec after VHF RNG - RSET.	1	Voice transmission at this time could interfere with the accuracy of ranging signal.

5.6.4

VHF AM RANGING MODE

NORMAL/BACKUP

APOLLO-SOYUZ TEST PROJECT (ASTP)
OPERATIONS HANDBOOK

STA/T STEP	PROCEDURE	PANEL	REMARKS
AC	VHF RNC - PSET (1 sec min) RNG ind - BBBB 0 (read BBBB.0)	9 1	PSET position is momentary, hold for 1 second minimum. When VHF RNC switch placed to PSET, RNC indicator will reset to zero, and operator will hear mid tone (3.95 kHz) and then low tone (247 Hz).
CP	If P20 operating VHF AM'ing option selected	2,140	TRACKER light - out (no OCDU failure) and RNC indicator starts counting up 4 seconds after termination of low tone. RNC indicator interpreted as range in nautical miles to nearest .XXM.
AC	TRACKER lt - out RNC ind - BXXX X (read BXXX.XX)	1	
	<u>5.6.5 Pad Communications</u>		
DP	Select Basic, 5.6.1 except TAPE RCDR FWD - off (ctr)	3	
ALL	Prior to launch VHF FM/PAD COMM (3) - T/R (or RCV) 9,10,6 VHF FM/PAD COMM VOL tw (3) - as req Launch -10:00 VHF FM/PAD COMM (3) - OFF	9,10,6	VHF FM/PAD COMM switch can be used after launch for intercom backup with VHF FM/PAD COMM VOL thumbwheel decreased.
	<u>5.6.6 S-Band Xponder Modes</u>		
ALL	Voice, RT-HBR Data, Ranging Sel Basic, 5.6.1 except PCM BIT RATE - HI Voice, RT-LBP Data, Ranging Sel Basic Voice, RT-HBR Data Sel Basic, except S BD MODE PNG - OFF PCM BIT RATE - HI	3	

S-BAND XPONDER MODES

APOLLO-SOYUZ TEST PROJECT (ASTP)
OPERATIONS HANDBOOK

STA/T STEP	PROCEDURE	PANEL	REMARKS
DP	<p>Voice, RT-LBR Data Sel Basic, except S BD MODE RNG - OFF</p> <p>Voice & Ranging Sel Basic, except S BD MODE PCM - ctr</p> <p>Voice Sel Basic, except S BD MODE PCM - ctr S BD MODE RNG - OFF</p> <p>Voice & LBR PCM with Apollo Range Instrumentation Aircraft (ARIA) Sel Basic, except S BD MODE RNG - OFF</p>	3	
5.6.7	<p><u>FM Xmtr Mode</u></p> <p>Dump PCM/Analog Sel Basic, 5.6.1 except TAPE RCDR FWD - REWIND S BD AUX TAPE - TAPE TAPE RCDR RCD - PLAY TAPE RCDP FWD - FWD (after rewind complete) TAPE MOTION tb - gray Rewind & return to Basic</p>		<p>Gray indicates tape in motion.</p>

FM XMTR MODE

5.6.7

NORMAL/BACKUP

APOLLO-SOYUZ TEST PROJECT (ASTP)
OPERATIONS HANDBOOK

STA/T STEP	PROCEDURE	PANEL	REMARKS
5.6.8	<u>DSE Record Modes</u>		
DP	Record HBR CM Data, CM/IC, DM/IC, EXP/ PCN Data Sel Basic, 5.6.1 except PCN BIT RATE - HI	3	Under nominal conditions STTN will control tape recorder operation. If degraded data is experienced by STTN, then the DSE should be operated 4 seconds in fast forward mode prior to recording flight data on the initial footage of tape.
CP	Record LBR CM Data, CM/IC, DM/IC, EXP/PCM Data Sel basic		
5.6.9	<u>Relay Mode (VHF FM to MCC-H via SBD)</u>	10	
CP	Select Basic, 5.6.1, except MODE - VOX VOX SENS tw - 8 VHF FM/PAD COMM - RCV VHF FM/PAD COMM tw - 5 S BD VOL tw - full decr PER - AUDIO MASTER VOL tw - 3 INTERCOMM VOL tw - full decr VHF AM - OFF AUDIO CONT - BU		
5.6.10	<u>Sleep Configuration</u>	6	
DP	Select Basic, 5.6.1, except S BD - OFF		

SLEEP CONFIGURATION

APOLLO-SOYUZ TEST PROJECT (ASTP)
OPERATIONS HANDBOOK

STA/T STEP	PROCEDURE	PANEL	REMARKS
DP	VHF FN/PAD CONT - RCV INTERCOM - RCV	9	Requires coordination with STDN. Updata signal (noise) will be present in headsets until STDN reconfigures for this mode.
AC	VHF AN - OFF	10	
DP	AUDIO CONT - BU Config to Relay Mode, 5.6.9	3	
	<u>5.6.11 Backup Modes</u>		
	Up Voice Backup Sel Basic, except UP TIN DATA - UP VOICE BU		
	Down Voice Backup Sel Basic, except S BD MODE PCN - ctr S BD AUX TAPE - DN VOICE BU S BD MODI FNG - OFF PC: BIT RATE - HI		
	Down Voice & LBR RT Data Backup Sel Basic, 5.6.1, except S BD AUX TAPE - DN VOICE BU S BD MODE FNG - OFF		
	Key Sel Basic, except S BD MODE PCN - KEY S BD MODE FNG - OFF		
	Down Data Backup Sel Basic, except PNP PWP - AUX		

BACKUP MODES

5.6.11

NORMAL/BACKUP

APOLLO-SOYUZ TEST PROJECT (ASTP)
OPERATIONS HANDBOOK

STA/T STEP	PROCEDURE	PANEL	REMARKS
5.6.12	<u>TV Oper</u>		
	<u>TBD</u>		
5.6.13	TV Modes		For DM TV checkout and TV crew transfers, refer to 18.5.2 and 18.5.3.
	<u>TBD</u>		

TV OPER

APOLLO-SOYUZ TEST PROJECT (ASTP)
OPERATIONS HANDBOOK

STA/T STEP	PROCEDURE	PANEL	REMARKS
5.7	MECHANICAL SYSTEMS		
5.7.1	<u>Forward Hatch Removal</u>		
DP	Opening Fwd Hatch From CM Interior Equalize CM/DM press		If required. Tunnel pressure integrity check is incorporated into these procedures.
	Actr handle rel - PULL & ROTATE	Tun1	To free actuator handle for operation, release is rotated to stop.
	Actr handle - pull to stop		Actuator handle should move $\approx 80^\circ$.
	Actr handle sel - U (unlatch)		Actuator handle should move $\approx 60^\circ$ to release latches.
	Actr handle - push to stop		
	Gearbox disconnect socket - U (verify)		
	Actr handle sel - STOP		Actuator handle release automatically locks handle in stowed position.
	Actr handle - push to stowed position		
	Remove & stow fwd hatch		Hatch should be stowed in LHEB.
5.7.2	<u>Forward Hatch Installation</u>		
DP or CP	Closing Fwd Hatch From CP Interior Obtain fwd hatch from stowage Position hatch against sealing surface	Fwd hatch	Performed by DP or CP. Forward hatch stowed in LHEB. Align equivalent colored arrows.
	Actr handle rel - PULL & ROTATE		To free actuator handle for operation, release rotated to stop.

5.7.2

FORWARD HATCH INSTALLATION

NORMAL/BACKUP

APOLLO-SOYUZ TEST PROJECT (ASTP)
OPERATIONS HANDBOOK

STA/T STEP	PROCEDURE	PANEL	REMARKS
DP or CP	Actr handle - pull to stop Actr handle sel - L (latch) Actr handle - push to stop Verify gearbox disconnect socket is opposite L mark on hatch Actr handle sel - STOP Actr handle - push to stowed position	Fwd hatch	Actuator handle should move $\approx 80^\circ$. Actuator handle should move $\approx 60^\circ$ to engage latches. Actuator handle release automatically locks handle in stowed position.
AC	Push man gearbox lock (chrome tab) PRESS EQUAL vlv - CLOSE (CW)		Verifies that gear box lock is engaged. Yellow indicator pin must be in green zone and valve handle must be in yellow-band area (indicates valve is fully closed).
	Cannot close PPESS EQUAL vlv Remove fwd hatch, 5.7.1 Insert Tool B in external tool interface for additional leverage, hold depressed & rot (CCW) Install fwd hatch		
CF	Secure tuml hatches Verify DN hatch is closed & vlv properly set CAB PPFSS ind - 4.7-5.3 psia (verify)	2	

FORWARD HATCH SEAL INTEGRITY CHECK

APOLLO-SOYUZ TEST PROJECT (ASTP)
OPERATIONS HANDBOOK

STA/T STEP	PROCEDURE	PANEL	REMARKS
CP	TUNL VENT vlv - TUNL VENT for >10 min TUNL LT - OFF	12 274	
5.7.4 Docking Probe Removal			
AC	1 Panel and tunnel configuration PROBE (3) - OFF ch DOCK PROBE (2) - open Fwd hatch removed, 5.7.1	2 8 tum1	PROBE EXTD/REL switch is guarded.
CP	2 Verify extend latch engaged, ind (red) not visible XXX X If extend latch not engaged, indicator (red) not flush with latch housing Preload sel lever - rotate CW (away from orange stripe) Preload handle - torque CCW until extend latch engages, indicator (red) not visible XXX X		
CP	CN2 bleed button (red) - press (10 sec)	tum1	CN2 bleed button (red) located under pyro components cover, depressurizes probe retract system when depressed.

DOCKING PROBE REMOVAL

AGELLO-COYDEZ TEST PROJECT (ASTP)
OPERATIONS HANDBOOK

STA/T STEP	PROCEDURE	PANEL	REMARKS
CP	<p>Preload sel lever - rotate CCM (parallel to orange stripe) Preload handle - torque CM until load removed from support bears</p>	tuml	Support bears may become loose in docking rir sockets.
3	<p>Disconnect & stow probe umbilicals Pull first connector shell (yellow) & rotate CCM to unlock Pull connector to remove Align yellow mark with stowage connector (yellow) & push to engage</p>		Stowage connector located on aft side of support bears.
4	<p>Fold probe Pull instal strut fror clip on support bear, rotate foot 180° & position against tuml wall between yellow marks Depress ratchet handle rel button (gray) & pull ratchet handle aft to full extension</p>		Ratchet handle rel button (gray) is on aft end of ratchet handle.

5.7.4

DOCKING PROBE REMOVAL

NORMAL/BACKUP

APOLLO-SOYUZ TEST PROJECT (ASTP)
OPERATIONS HANDBOOK

STA/T STEP	PROCEDURE	PANEL	REMARKS
CP	<p>Depress ratchet handle rel button (gray) & push ratchet handle to first detent (red band only visible) Push ratchet handle outboard 30° & hold allowing probe to fold</p> <p>XXX X</p> <p>Probe will not fold Using tool F, rotate jam nut & hex bolt (ratchet handle stop) CCF to remove bolt Push ratchet handle outboard until probe releases & hold until probe folds (Subs instal of probe must be done very carefully to avoid releasing ratchet & folding probe while attempting to install it)</p> <p>XXX X</p> <p>Depress ratchet handle rel button (gray) & pull ratchet handle aft to full extension Push ratchet handle outboard 25° for one stroke only Depress ratchet handle rel button (gray) & with ratchet handle held inboard, push fully fwd to stow position Rotate instal strut foot 180° to stow position & restow instal strut in clip on support bear.</p>	<p>tun1</p>	<p>Probe fully folded when Teflon block on Z-support bear within 1/4 inch of ratchet housing.</p>

DOCKING PROBE REMOVAL

APOLLO-SOYUZ TEST PROJECT (ASTP)
OPERATIONS HANDBOOK

STA/T STEP	PROCEDURE	PANEL	REMARKS
CP	<p>Verify capture latch cocked (plunger recessed below probe head cap) Remove and stow capture latch rel tool Remove probe from tuml & stow as req</p>	tum1	<p>For storage, reference NASA document (TBD).</p>
5.7.5	<p><u>Docking Probe Installation</u></p>		
1	<p>Panel and tunnel configuration PROBE (3) - OFF (verify) cb DOCK PROBE (2) - open Droque installed, 5.7.8</p>	2 8	<p>PROBE EXT/REL switch guarded.</p>
2	<p>Remove probe from stowage</p>		
3	<p>Engage capture latches Push probe head into droque until capture latches engage & lock</p>		<p>A slight pull in aft direction will disengage capture latches if not fully engaged.</p>
4	<p>Engage probe in docking ring Pull instal strut from clip on support beam, rotate foot 180° & position against tum1 wall between yellow marks Depress ratchet handle rel button (gray) and pull ratchet handle aft to full extension (green & red bands visible) Push ratchet handle outboard 25° to stop & repeat until probe support beams (3) engage in docking ring sockets</p>		<p>Yellow marks located on -Z axis. Probe support beam and corresponding docking ring socket color-coded yellow. Ratchet handle release button (gray) on aft end of ratchet handle. From this point ≈ 19 strokes required to install probe. An orange hash mark on collar conduit becomes visible when fully installed. Care should be exercised to ensure probe support beams (3) align with docking ring sockets and end of pitch arms do not interfere with docking latch fairings.</p>

DOCKING PROBE INSTALLATION

APOLLO-SOYUZ TEST PROJECT (ASTP)
OPERATIONS HANDBOOK

STA/T STEP	PROCEDURE	PANEL	REMARKS
CP	<p>XXX X If pushing ratchet handle outboard does not advance support beams to engage docking ring sockets Depress ratchet handle rel button (gray) & push ratchet handle fwd to first deten. (red band only visible) Slowly push ratchet handle outboard 25° until ratchet pawl engages (audible click) & repeat until 3 probe support beams engage in docking ring sockets (If ratchet handle pushed outboard past point of pawl engagement, probe will release)</p>	<p>XXX X Verify ratchet pawl ind (red) flush with ratchet housing XXX X If ratchet pawl ind protruding above ratchet housing Push ratchet handle outboard 25° to stop & hold Press ratchet pawl ind (red) to seat pawl (ind flush) Return ratchet handle to full inboard position XXX X</p>	<p>If ratchet pawl not audible, watch action of ratchet pawl indicator (red).</p>

DOCKING PROBE INSTALLATION

5-7-5

NORMAL/BACKUP

APOLLO-SOYUZ TEST PROJECT (ASTP)
OPERATIONS HANDBOOK

STA/T STEP	PROCEDURE	PANEL	REMARKS
CP	<p>Depress ratchet handle rei button (gray) & with ratchet handle held inboard, push fully fwd to stow position</p> <p>Rotate instal strut foot 180° to stow position & restow instal strut in clip on support beam</p>	tuml	<p>This step required only if probe installed in tunnel for stowage. Support beams may become loose in docking ring sockets. Rotate preload sel lever CCM (parallel to orange stripe) to move extend latch aft (compress probe) and CM (away from orange stripe) to move extend latch fwd (expand probe).</p>
5	<p>Adjust preload handle in direction req to maintain support beams in an unloaded condition</p>	<p>Position preload handle at 45° angle to support beam (either side)</p>	<p>Position provides clearance with fwd hatch actuator handle.</p>
6	<p>Push preload shaft fwd into detent</p>		<p>This step not required when installing probe for stowage.</p>
7	<p>Connect probe umbilicals</p>	<p>Pull probe umbilicals covers (2) (yellow) inboard & rotate fwd to open</p> <p>Pull first connector shell (yellow) aft & rotate CCM to unlock</p> <p>Pull connector to remove</p> <p>Align with docking ring connector (yellow) & push to engage</p> <p>Rotate connector shell CM to lock</p> <p>Repeat for sec probe umbilical (yellow)</p> <p>GN2 bleed button (red) - press (10 sec)</p>	<p>Probe umbilical covers located in docking rings.</p> <p>Probe umbilical connectors are stowed on probe support beams.</p>

DOCKING PROBE INSTALLATION

APOLLO-SOYUZ TEST PROJECT (ASTP)
OPERATORS HANDBOOK

STA/T STEP	PROCEDURE	PANEL	REMARKS
5.7.6	Docking System Probe Extension and Status Check	8	
AC	cb DOCK PPOBE (2) - close (verify)	8	
	<u>CAUTION</u>		
	PROBE EXTID/REL should not be held in EXTID/REL position longer than 20 sec if probe has not extended. Capability of capture latch release motors may be degraded.		
CP	PROBE EXTID/FIL - EXTID/REL and hold until probe fully extended PROBE EXTID/REL tb (2) - gray to bp to gray PROBE RETR (2) - OFF (verify)	2	Guarded. EXTID/REL position is momentary. Probe extended by compression spring and attenuator airhead forces. Crew should readily sense by auditory cues that probe has extended when probe strikes stops. Crew may not see talkback's go barber pole because of rapid probe motion. Barber pole indicates power to tb through probe circuitry. Return to gray indicates full extension of probe.
	PROBE EXTID/REL - RETR		Guarded.
	PROBE EXTID/REL tb (2) - gray (verify)		Verifies capture latches not locked and probe fully extended or capture latches not locked and probe has partially extended (3/4 inch).

DOCKING SYSTEM PROBE EXTENSION AND STATUS CHECK

5.7.6

NORMAL/BACKUP

APOLLO-SOYUZ TEST PROJECT (ASTP)
OPERATIONS HANDBOOK

STA/T STEP	PROCEDURE	PANEL	REMARKS												
	<table border="1"> <thead> <tr> <th data-bbox="269 497 347 608">PROBE POSITION</th> <th data-bbox="269 608 347 1161">PPOBE EXTID/REL sv POSITION</th> </tr> <tr> <td data-bbox="269 608 347 663"></td> <td data-bbox="269 663 347 1161"> <table border="1"> <thead> <tr> <th data-bbox="269 663 347 774">EXTD/REL</th> <th data-bbox="269 774 347 1161">PETR</th> </tr> </thead> <tbody> <tr> <td data-bbox="269 774 347 840">FULL EXTID</td> <td data-bbox="269 840 347 1161">gray</td> </tr> <tr> <td data-bbox="269 840 347 906">FULL PETR</td> <td data-bbox="269 906 347 1161">bp</td> </tr> <tr> <td data-bbox="269 906 347 973">PARTIAL EXTID</td> <td data-bbox="269 973 347 1161">bp</td> </tr> </tbody> </table> </td> </tr> </thead> </table>	PROBE POSITION	PPOBE EXTID/REL sv POSITION		<table border="1"> <thead> <tr> <th data-bbox="269 663 347 774">EXTD/REL</th> <th data-bbox="269 774 347 1161">PETR</th> </tr> </thead> <tbody> <tr> <td data-bbox="269 774 347 840">FULL EXTID</td> <td data-bbox="269 840 347 1161">gray</td> </tr> <tr> <td data-bbox="269 840 347 906">FULL PETR</td> <td data-bbox="269 906 347 1161">bp</td> </tr> <tr> <td data-bbox="269 906 347 973">PARTIAL EXTID</td> <td data-bbox="269 973 347 1161">bp</td> </tr> </tbody> </table>	EXTD/REL	PETR	FULL EXTID	gray	FULL PETR	bp	PARTIAL EXTID	bp		Probe position indications.
PROBE POSITION	PPOBE EXTID/REL sv POSITION														
	<table border="1"> <thead> <tr> <th data-bbox="269 663 347 774">EXTD/REL</th> <th data-bbox="269 774 347 1161">PETR</th> </tr> </thead> <tbody> <tr> <td data-bbox="269 774 347 840">FULL EXTID</td> <td data-bbox="269 840 347 1161">gray</td> </tr> <tr> <td data-bbox="269 840 347 906">FULL PETR</td> <td data-bbox="269 906 347 1161">bp</td> </tr> <tr> <td data-bbox="269 906 347 973">PARTIAL EXTID</td> <td data-bbox="269 973 347 1161">bp</td> </tr> </tbody> </table>	EXTD/REL	PETR	FULL EXTID	gray	FULL PETR	bp	PARTIAL EXTID	bp						
EXTD/REL	PETR														
FULL EXTID	gray														
FULL PETR	bp														
PARTIAL EXTID	bp														
5.7.7	<u>Docking Drogue Removal</u>														
CP	Drogue probe removal, 5.7.4 Pull & rotate (CC) drogue lock lever until flush against tunl wall Remove drogue Drogue outer ring is grasped with both hands at opposite sides Rotate (C) & push until 3 drogue lugs clear support fittings Pctate toward CN & grasp any 2 handles Mvr drogue past support fittings & stow in CN	tunl	Care must be taken not to stroke DM hatch. Drogue must be canted and rotated to clear tunnel. For stowage, reference NASA document (TBD).												
5.7.8	<u>Docking Drogue Installation</u>														
	Procure drogue from stowage														

DOCKING DROGUE INSTALLATION

APOLLO-BOYUZ TEST PROJECT (ACTP)
OPERATIONS HANDBOOK

STA/T STEP	PROCEDURE	PANEL	REMARKS
CP	<p>Install drogue Nvr past support fitting DM tun1</p> <p>Align drogue lugs (3) with support fittings in DM tunnel</p> <p>Pull drogue lugs into support fittings & rotate (CCW) until lugs hit stops in support fittings</p> <p>Push & rotate drogue latch lever 90° (CW)</p> <p>5.7.9 <u>Probe Preload Operation</u></p> <p>Rotate preload select lever CCW (parallel to orange stripe)</p> <p>Torque preload handle CW until load limiter releases</p> <p>Push preload handle inboard to detent & position at 45° angle to support bear (either side)</p> <p>Rotate preload sel lever to mid-position</p>	tun1	<p>Drogue must be canted and rotated to clear support fittings in tunnel. Limited clearance between DM hatch and support fittings requires care in maneuvering drogue if closed. Handles should be used for support.</p> <p>Drogue must be held along outer diameter at opposite sides adjacent to drogue lugs. At this point drogue handles are facing DM hatch.</p> <p>Ramps on support fittings will guide drogue lugs into support fitting recesses.</p> <p>Locks drogue latch mechanism.</p> <p>Preload handle extension may be telescoped outboard to provide additional leverage if required.</p> <p>Position provides clearance with fwd hatch handle.</p>

5.7.9

PROBE PRELOAD OPERATION

NORMAL/BACKUP

APOLLO-SOYUZ TEST PROJECT (ASTP)
OPERATIONS HANDBOOK

STA/T STEP	PROCEDURE	PANEL	REMARKS
5.7.10	<u>Tunnel Latch Operations</u>		
CP 1	Verify probe is preloaded, 5.7.9	tun1	
2	Cocking of latches		Any suitable tool may be used to trigger release lever if desired.
	<p style="text-align: center;"><u>WARNING</u></p> <p>To avoid possible injury to fingers or damage to PCA, care must be taken not to place fingers under or near a latch while cocking, nor under or near the latch hook of a cocked latch.</p>		
	Depress rel button behind handle latch grip & pull latch handle down two complete strokes		This procedure disengages and cocks latch. It may take only one complete stroke to cock each latch.
	<p>XXX X</p> <p>If latch handle cannot be pulled While pulling handle, depress rh no-back pawl on bottom until it disengages from ratchet tooth If latch handle pulls free, remove pressure from rh no-back pawl & complete cocking procedures If latch handle still cannot be pulled While pulling handle, depress lh no-back pawl through fairing covering hole with tools E & R until ratchet tooth disengages & latch handle pulls free</p>		

TUNNEL LATCH OPERATIONS

APOLLO-SOYUZ TEST PROJECT (ASTP)
OPERATIONS HANDBOOK

STA/T STEP	PROCEDURE	PANEL	REMARKS
CP	<p>Remove pressure from lh no-back pawl & complete cocking procedure If latch handle still cannot be pulled Remove fairing covering lh no-back pawl (using tools E & R) While pulling handle, depress both no-back pawls on bottom until ratchet teeth are disengaged & latch handle pulls free Remove pressure from both no-back pawls & complete cocking procedure XXXXXXXXXXXXXXXXXXXXXXXXXXXXXXXXXXXXX</p>	<p>tun1</p>	
	<p>Verify hook rotates inboard to clear DM ring XXXXXXXXXXXXXXXXXXXXXXXXXXXXXXXXXXXXX</p>		
	<p>If latch hook does not release from DM ring on first stroke Push top of AUX REL (yellow) button & proceed with sec stroke XXXXXXXXXXXXXXXXXXXXXXXXXXXXXXXXXXXXX</p>		
	<p>Verify/push latch handle outboard against latch hook 3 Repeat 2 until all 12 latches are disengaged & cocked</p>		<p>Prevents latch handle sticking inboard which could prevent latch primary tripper from resetting after undocking. Latches reset for subsequent docking operations.</p>

5.7.10 TUNNEL LATCH OPERATIONS

NORMAL/BACKUP

APOLLO-SOYUZ TEST PROJECT (ASTP)
OPERATIONS HANDBOOK

STA/T STEP	PROCEDURE	PANEL	REMARKS
CP 4	Manual tripping of latches Push manual release lever at side of latches	tum1	This procedure engages latch. Manual release lever located at lower right side of latch handle. Use tool I to push manual release lever.

TUNNEL LATCH OPERATIONS

5.7.10

AIOLLO-SOYUZ TEST PROJECT (ASTP)
OPERATIONS HANDBOOK

STA/T STEP	PROCEDURE	PANEL	REMARKS
5.8	FLOODLIGHT OPERATING MODES		
5.8.1	<u>Prim Floodlight Mode</u>	5,8,100	
ALL	FLOOD LTS - OFF (CCW) FLOOD DIM - 1 FLOOD LTS - full dim or full BRT		
5.8.2	<u>Sec Floodlight Mode</u>		
	FLOOD LTS - OFF (CCW) FLOOD DIM - 2 FLOOD LTS - full BRT (CW)		Operation in secondary mode is a backup only to be used in the event of DIM-1 circuitry in-flight failure. The DIM-2, dimmed floodlight predicted operating life is =100 hours.

5.8.2 SEC FLOODLIGHT MODE

NORMAL/BACKUP

6.0 G&C REFERENCE DATA

This section provides data which generally apply to all G&C procedures in sections 7 through 21. The data do not include procedures but contain information which may be referenced in various procedures, may contain application of procedures, or may be helpful in applying the procedures.

6.1 G&C OPERATING NOTES

G&C operating notes are separated into three categories: G&C operations, SCS operations, and G&N operations. Notes for G&C operations provide data associated with guidance and control functions in general while notes for SCS and G&N operations are more specific to their systems.

6.1.1 G&C Operations

1. ULLAGE: For ullage switch setup with or without attitude control, see figure 6-1. Normally, the setup should include attitude control.
2. RCS JET, VENT, RADIATOR, AND ANTENNA LOCATIONS: SM and CM RCS jets, vent, and radiator locations are illustrated in figure 6-2.
3. SCS LOGIC BUS POWER DISTRIBUTION: SCS logic bus circuit breakers on panel 8 provide VMA and MNB power to four SCS logic buses. Figure 6-3 delineates power source and power distribution for SCS controls (pushbuttons, functions, and switches).
Main bus power to SCS logic buses 1 and 4 is controlled only by the SCS logic bus circuit breakers on panel 8. Power to SCS logic buses 2 and 3 is controlled by SCS logic bus circuit breakers on panel 8 and the LOGIC 2/3 PWR switch on panel 7. Other than SCS TVC, equipment loads can only be removed from a specific logic bus by selecting acceptable control positions not powered by that bus. (See figure 6-3.)
For SCS logic bus power loss and SCS logic bus power loss (special effects), see figures 6-4 and 6-5.
4. AC/DC BUS LOSS: Figure 6-6 relates ac and dc bus loss effects to G&C component functional capabilities. As shown, a functional capability may be only partially lost, or lost entirely.

6.1.1

G&C OPERATIONS

NORMAL BACKUP

APOLLO-SOYUZ TEST PROJECT (ASTP)
OPERATIONS HANDBOOK

Type of Ullage Desired		Required AUTO RCS Switch Positions (Jets Firing*)												RCS Jets* Providing Attitude Hold Capability			
		Pitch						Yaw								Pitch	Yaw
		A3	C3	A4	C4	B3	D3	B4	D4								
2 Jet - Quad A/C Pitch Jets C3 and A4	Without Attitude Control	OFF	MNA or MNB	MNA or MNB	OFF	MNA or MNB	OFF	MNA or MNB	OFF	MNA or MNB	OFF	OFF	MNA or MNB	None	B3 and B4		
	With Attitude Control	MNA or MNB	MNA or MNB	MNA or MNB	MNA or MNB	MNA or MNB	MNA or MNB	MNA or MNB	MNA or MNB	MNA or MNB	MNA or MNB	MNA or MNB	MNA or MNB	A3 and C4	B3 and B4		
2 Jet - Quad B/C Yaw Jets B3 and B4	Without Attitude Control	MNA or MNB	OFF	OFF	MNA or MNB	OFF	MNA or MNB	MNA or MNB	MNA or MNB	MNA or MNB	MNA or MNB	MNA or MNB	OFF	A3 and C4	None		
	With Attitude Control	MNA or MNB	OFF	OFF	MNA or MNB	MNA or MNB	MNA or MNB	MNA or MNB	MNA or MNB	MNA or MNB	MNA or MNB	MNA or MNB	MNA or MNB	A3 and C4	B3 and B4		
4 Jet - Quad ABCD Jets A4, B4, C3, D3	Without Attitude Control	OFF	MNA or MNB	MNA or MNB	OFF	OFF	MNA or MNB	MNA or MNB	MNA or MNB	MNA or MNB	MNA or MNB	MNA or MNB	OFF	None	None		
	With Attitude Control	MNA or MNB	MNA or MNB	MNA or MNB	MNA or MNB	MNA or MNB	MNA or MNB	MNA or MNB	MNA or MNB	MNA or MNB	MNA or MNB	MNA or MNB	MNA or MNB	A3 and C4	B3 and B4		

*See figure 6-2 for explanation of jet code.

Figure 6-1. SCS Ullage Setup

G&C OPERATIONS

APOLLO-SOYUZ TEST PROJECT (ASTP)
OPERATIONS HANDBOOK

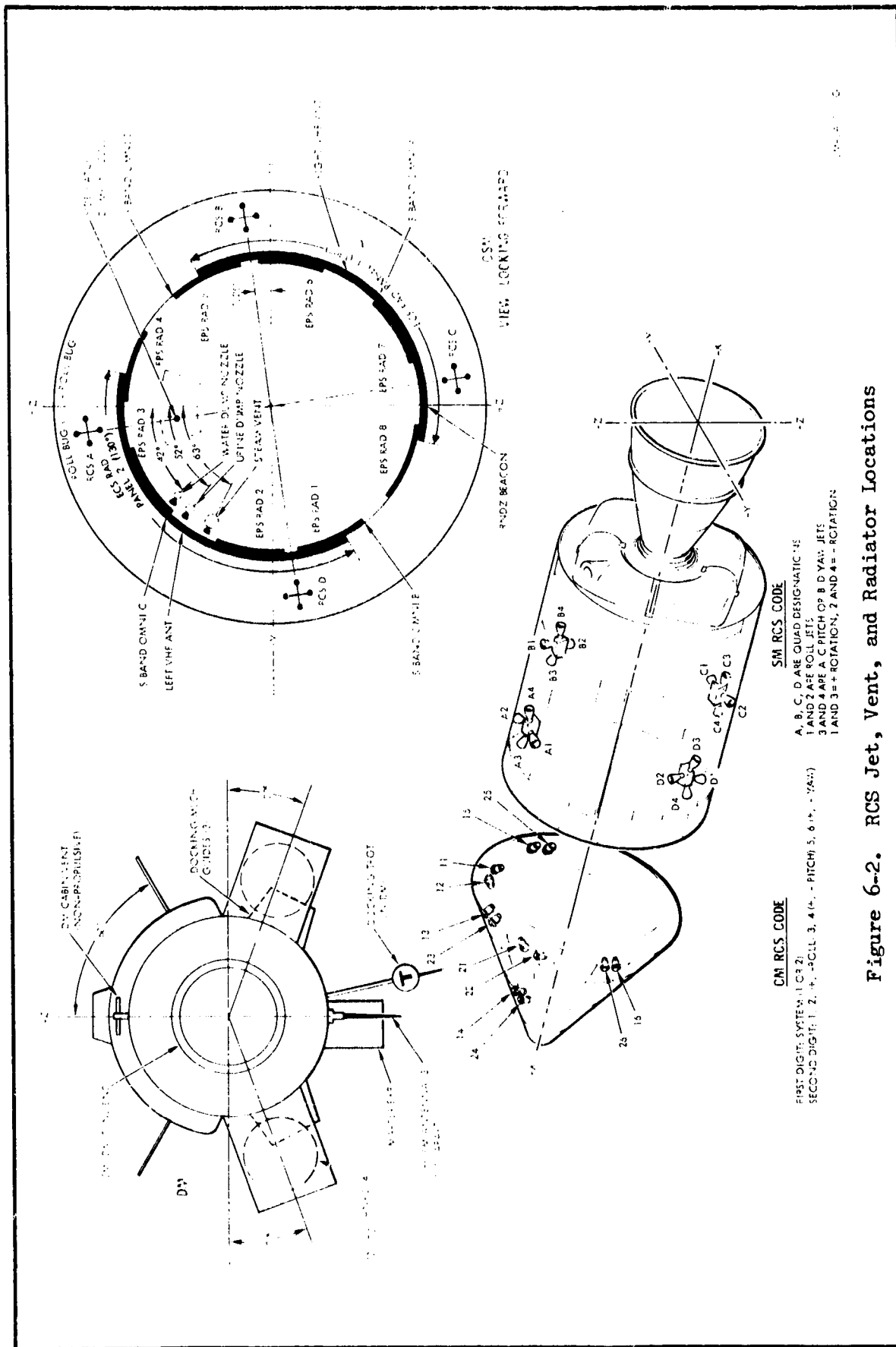

Figure 6-2. RCS Jet, Vent, and Radiator Locations

G&C OPERATIONS

6.1.1

NORMAL BACKUP

APOLLO-SOYUZ TEST PROJECT (ASTP)
OPERATIONS HANDBOOK

CONTROLS		POWER SOURCE				POWER OFF	
		BUS 1 (cb direct)	BUS 2 (LOGIC 2/3 PWR sw)	BUS 3 (LOGIC 2/3 PWR sw)	BUS 4 (cb direct)	OPEN CIRCUIT	SWITCHED OFF BY
TITLE	POSITIONS						
CMC ATT	IMU	X			X		cb SCS LOGIC 1/2, 1/4, & 3/4
	GDC					X	
FDAI SCALE	5/1					X	LOGIC 2/3 PWR cb SCS LOGIC 1/4 & 3/4
	5/5		X		X		
	50/15/50/10						
FDAI SEL	1/2				X		cb SCS LOGIC 1/4 & 3/4
	1			X			
FDAI SOURCE	2			X			LOGIC 2/3 PWR LOGIC 2/3 PWR LOGIC 2/3 PWR
	CMC		X				
	ATT SET						
ATT SET	GDC			X			LOGIC 2/3 PWR LOGIC 2/3 PWR LOGIC 2/3 PWR
	IMU						
	GEC		X				
VAN ATT (3)	ACCEL CMD	X					cb SCS LOGIC 1/2 & 1/4
	RATE CMD					X	
	MIN IMP	X					
LIM CYCLE	on (up)						cb SCS LOGIC 1/2 & 1/4
	OFF	X				X	
ATT DBD	MAX						cb SCS LOGIC 1/2 & 1/4
	MIN	X				X	
RATE	HI	X					cb SCS LOGIC 1/2 & 1/4
	LO					X	

Figure 6-3. SCS Logic Bus Power Distribution (Sheet 1 of 2)

G&C OPERATIONS

APOLLO-SOYUZ TEST PROJECT (ASTP)
OPERATIONS HANDBOOK

CONTROLS		POWER SOURCE				POWER OFF	
		BUS 1 (cb direct)	BUS 2 (LOGIC 2/3 PWR sw)	BUS 3 (LOGIC 2/3 PWR sw)	BUS 4 (cb direct)	OPEN CIRCUIT	SWITCHED OFF BY
TITLE	POSITIONS						
SC CONT	CMC		X				LOGIC 2/3 PWR
	SCS			X			LOGIC 2/3 PWR
EMAG MODE	RATE 2		(R)	(P & Y)			LOGIC 2/3 PWR
	ATT 1/RATE 2		(R)	(P & Y)			LOGIC 2/3 PWR
	RATE 1		(R,P,Y)				cb SCS LOGIC 1/2 & 1/4
DIR ULL	pb	X					cb SCS LOGIC 1/2 & 1/4
THRUST ON	pb	X					cb SCS LOGIC 1/2 & 1/4
SFC ALIGN	pb				X		cb SCS LOGIC 1/4 & 3/4
SCS TVC (2)	AUTO			X			LOGIC 2/3 PWR
	RATE CMD			X			LOGIC 2/3 PWR
	ACCEL CMD			X			LOGIC 2/3 PWR
ATVC GAIN	LO			X			LOGIC 2/3 PWR
	HI					X	LOGIC 2/3 PWR
EMS FOLL	on (up)				X		cb SCS LOGIC 1/4 & 3/4
	OFF					X	
.05 G sw	on (up)		X		X		cb SCS LOGIC 1/4 & 3/4
	OFF						LOGIC 2/3 PWR
TVC GMBL DR (2)	1					X	
	AUTO	X					cb SCS LOGIC 1/2 & 1/4
THC	2			X			LOGIC 2/3 PWR
	CW sw		X				LOGIC 2/3 PWR

Figure 6-3. SCS Logic Bus Power Distribution (Sheet 2 of 2)

G&C OPERATIONS

6.1.1

NORMAL BACKUP

CAUTION

SCS logic bus power must not be removed from CMC ATT switch if (1) pitch or yaw rate $>5^\circ/\text{second}$, or (2) GDC yaw Euler angle $>80^\circ$ and $<280^\circ$. Removing power when either of these conditions exist will result in GDC damage.

5. LIMITED USE CONTROLS: G&C circuit breakers, required for G&C operation, are to be closed during the entire mission except in event of malfunctions. (See figure 6-7.) If a malfunction occurs, some circuit breakers may be operated in order to isolate problem areas. Refer to malfunction procedures in Flight Data File (FDF).

Figure 6-8 defines switches which will remain in same position during major portion of orbital flight time because of functional requirements. Other considerations are to maintain maximum crew safety, increase equipment reliability, and minimize power consumption.

6. ATT SET - IMU FUNCTION: If CMC is on, an overload in IMU resolver circuitry may cause an ICDC oscillation and trigger the ISS warning light (Reference ICD MH01-01325-210). IMU must be used only as a null meter in this mode of operation. If not, large errors will result because of impedance mismatch. ATT SET switch should be left at GDC when not in use. A polarity reversal occurs when ATT SET - IMU option is selected, and roll gimbal angle $>+90^\circ$. The pitch and yaw attitude error needles become "fly from" indicators rather than "fly to" indicators in this instance.

7. LOGIC 2/3 PWR switch: Required "on" for proper control/display functions (G&N or SCS modes). See figure 6-3 for switches whose positions are dependent on this switch being on for proper system operation.

8. MANEUVER $>17^\circ$: For CMC maneuvers $>17^\circ$ and during SIVB or Soyuz maneuvers, the EMAGs should be caged to prevent them from hitting their stops.

G&C OPERATIONS

APOLLO-SOYUZ TEST PROJECT (ASTP)
OPERATIONS HANDBOOK

	SCS LOGIC BUS POWER LOSS											
	BUS 1			BUS 2			BUS 3			BUS 4		
	FUNCTION(S) LOST	CORRECTIVE ACTION SELECT	FUNCTION(S) LOST	CORRECTIVE ACTION SELECT	FUNCTION(S) LOST	CORRECTIVE ACTION SELECT	FUNCTION(S) LOST	CORRECTIVE ACTION SELECT	FUNCTION(S) LOST	CORRECTIVE ACTION SELECT	FUNCTION(S) LOST	CORRECTIVE ACTION SELECT
CONTROL												
FOAI SCALE			5/5	5/1 50/15								50/15 5/1
FOAI SEL					1 & 2	1/2						1 2
FOAI SOURCE			CMC	GDC ATT SET								
ATT SEL			IMU	GDC								IMU
MAN ATT (3)	ACCEL CMD MTR IMP	RATE CMD										
LEM CYCLE	OFF	on (up)										
ATT LED	MIN	MAX										
FAIR	HI	LO										
TIC												
ST CONT			CW	neutral								
EMAG MODE (3)	RATE 1	ATT 1/RATE 2 RATE 2	(R) RATE 2 ATT 1/RATE 2	(R) RATE 1 ATT 1/RATE 2	SCS	(P, Y) RATE 2 ATT 1/RATE 2						
DIP SWL pb	push (logic only)											
EMUSI ON pb	push											
SDC ALIGN												push
SCS TVC (2)												
ATVC GAIN												
EMS ROLL												
.05 G SW			OFF	OFF								on (up) .05 G
TVC GMBL DR (2)	AUTO											
		1										
		2										

SM-2A-SL-2019

Figure 6-4. SCS Logic Bus Power Loss

G&C OPERATIONS

6.1.1

NORMAL BACKUP

APOLLO-SOYUZ TEST PROJECT (ASTP)
OPERATIONS HANDBOOK

MODE EFFECT	BUS 1 LOSS	BUS 2 LOSS	BUS 3 LOSS	BUS 4 LOSS
CMC CONTROL MODE (SC CONT - CMC)	<ul style="list-style-type: none"> • No effect 	<ul style="list-style-type: none"> • CMC attitude control may exist since G&H power not affected by LOGIC BUS 2 short • ACCEL CMD (CMC) lost 	<ul style="list-style-type: none"> • No effect 	<ul style="list-style-type: none"> • No effect
RCS CONTROL	<p><u>Direct RCS:</u></p> <ul style="list-style-type: none"> • Operational including direct ullage <p><u>SCS/SM RCS:</u></p> <ul style="list-style-type: none"> • Control modes restricted to positions shown for BUS 1 corrective action, figure 6-4 	<p><u>Direct RCS:</u></p> <ul style="list-style-type: none"> • Operational including direct ullage <p><u>SCS/SM RCS:</u></p> <ul style="list-style-type: none"> • P & Y not affected • For manual roll BMAG MODE (R) - RATE 1 • MAN ATT (R) - RATE CMD, ACCEL CMD or MIN IMP • For SCS att hold (R) BMAG MODE (R) - ATT 1/RATE 2 • LIM CYCLE - on (up) 	<p><u>Direct RCS:</u></p> <ul style="list-style-type: none"> • Operational including direct ullage <p><u>SCS/SM RCS:</u></p> <ul style="list-style-type: none"> • MAN ATT (3) - ACCEL CMD operational (CMC or SCS) • MAN ATT (3) - MIN IMP operational if THC - CW • MAN ATT (R) - RATE CMD operational if THC-CW & SC CONT - CMC • MAN ATT (P,Y) - RATE CMD operational if THC-CW & BMAG MODE - RATE 1 • or ATT 1/RATE 2 & LIM CYCLE - on (up) 	<p><u>Direct RCS:</u></p> <ul style="list-style-type: none"> • Operational including direct ullage <p><u>SCS/SM RCS:</u></p> <ul style="list-style-type: none"> • No effect
	<p><u>SCS/CM RCS:</u></p> <ul style="list-style-type: none"> • Use direct RCS only • Disable auto RCS RCS CMD - OFF or AUTO RCS (12) - OFF • Use single ring only 	<p><u>SCS/CM RCS:</u></p> <ul style="list-style-type: none"> • P & Y not affected • Roll axis BMAG MODE (R) - RATE 1 • MAN ATT (R) - RATE CMD or ACCEL CMD • .05 G function operational 	<p><u>SCS/CM RCS:</u></p> <ul style="list-style-type: none"> • Roll to yaw coupling loss for post .05 G 	

SM-2A-5L-2020

Figure 6-5. SCS Logic Bus Power Loss (Special Effects) (Sheet 1 of 4)

G&C OPERATIONS

APOLLO-SOYUZ TEST PROJECT (ASTP)
OPERATIONS HANDBOOK

MODE EFFECT	BUS 1 LOSS	BUS 2 LOSS	BUS 3 LOSS	BUS 4 LOSS
SPS CONTROL	<p><u>Gimbal Control:</u></p> <ul style="list-style-type: none"> • SCS auto TVC functional • MTVC rate cmd functional with: RMAG MODE (P,Y) - ATT 1/RATE 2 cr RATE 2 • No direct ullage (for logic) • ACCEL CMD operational • THC-CW operational • If servo 1 failure TVC GMBL DR (2) - 2 	<p><u>Gimbal Control:</u></p> <ul style="list-style-type: none"> • SC CONT - CMC (simultaneous CMC & SCS TVC occurs) • CMC AV capability exists if: SCS TVC (2) - ACCEL CMD • SCS trim to 0.0° • THC-CW switchover function lost - switch to 2 by TVC GMBL DR (2) - 2 	<p><u>Gimbal Control:</u></p> <ul style="list-style-type: none"> • SCS auto TVC lost • MTVC - Rate cmd operational with RATE 1 only • Accel cmd operational with RATE 2 (P,Y) • Manual switch to servo 2 with TVC GMBL DR - 2 is lost - Use: TVC GMBL DR (2) - AUTO • THC-CW 	<p><u>Gimbal Control:</u></p> <ul style="list-style-type: none"> • No effect
	<p><u>Thrust on/off:</u></p> <ul style="list-style-type: none"> • CMC thrust on not affected • Ullage - THC +X or DIR ULL as backup (no direct ullage for logic function) • SCS thrust on SPS THRUST - on (up) only • SCS thrust termination AV THRUST A (B) - OFF 	<p><u>Thrust on/off:</u></p> <ul style="list-style-type: none"> • No effect 	<p><u>Thrust on/off:</u></p> <ul style="list-style-type: none"> • CMC thrust on not affected • THRUST ON pb operational if THC-CW • AV ind operational (for thrust termination) 	<p><u>Thrust on/off:</u></p> <ul style="list-style-type: none"> • No effect

SM-2A-SL-2021

Figure 6-5. SCS Logic Bus Power Loss (Special Effects) (Sheet 2 of 4)

G&C OPERATIONS

6.1.1

NORMAL BACKUP

APOLLO-SOYUZ TEST PROJECT (ASTP)
OPERATIONS HANDBOOK

MODE EFFECT	BUS 1 LOSS	BUS 2 LOSS	BUS 3 LOSS	BUS 4 LOSS
THC	<ul style="list-style-type: none"> ● No effect 	<ul style="list-style-type: none"> ● THC-CW function lost - use SC CONT - SCS 	<ul style="list-style-type: none"> ● No effect 	<ul style="list-style-type: none"> ● No effect
DISPLAYS	<p>Pre/Post .05 G:</p> <ul style="list-style-type: none"> ● All displays operational except RATE 1 (No source for rate display or for att ref) 	<p>Pre-.05 G:</p> <ul style="list-style-type: none"> ● FDAI SEL - 1/2 operational except (ball 2) att error ● CMC source (ball 1) operational except CDU error ● Total att, att error (ball 2) lost if: FDAI SOURCE - CMC FDAI SEL - 2 ● Att error lost if: FDAI SOURCE - ATT SET ● ATT SET - IMU ● FDAI SCALE - 5/5 lost ● Yaw rate display indicates roll coupling ● R & P rate display normal ● BMAG R, P, Y att error (ball 2) lost if: FDAI SEL - 1/2 or FDAI SOURCE - GDC 	<p>Pre/Post .05 G:</p> <ul style="list-style-type: none"> ● FDAI SEL - 1/2 operational ● FDAI SEL - 1 & 2 lost (for both CMC or GDC) ● FDAI SOURCE - ATT SET function lost ● All displays (rate, att error, total att) valid for FDAI SEL - 1/2 only ● BMAG 1 & 2 rate valid 	<p>Pre/Post .05 G:</p> <ul style="list-style-type: none"> ● FDAI SCALE - 50/15 lost ● FDAI SEL - 1 or 2 only ● FDAI SOURCE - CMC or GDC operation: 1 ● GDC & RSI align lost

SM-2A-SL-2022

Figure 6-5. SCS Logic Bus Power Loss (Special Effects) (Sheet 3 of 4)

G&C OPERATIONS

APOLLO-SOYUZ TEST PROJECT (ASTP)
OPERATIONS HANDBOOK

MODE EFFECT	BUS 1 LOSS	BUS 2 LOSS	BUS 3 LOSS	BUS 4 LOSS
		<u>Post .05 G:</u> <ul style="list-style-type: none"> FDAI SEL - 1/2 operational Ball 1 - CMC source operational Ball 2 - CMC source lost SCS - total att, rate display, att errors normal 		<u>Post .05 G:</u> <ul style="list-style-type: none"> Display of roll to yaw coupling not void (actual coupling does not exist)
SM-2A-SL-2023				
Figure 6-5. SCS Logic Bus Power Loss (Special Effects) (Sheet 4 of 4)				
G&C FUNCTIONS LOST OR MODIFIED				
BUS LOSS				
G&C COMMENT	ACL	AC2	MNA	MNB
EMAG 1	<ul style="list-style-type: none"> Rate Error 		<ul style="list-style-type: none"> SMRD, C/W, htr Error 	
EMAG 2		<ul style="list-style-type: none"> Rate 		<ul style="list-style-type: none"> SMRD, C/W, htr
FHC 1	<ul style="list-style-type: none"> Rate cmd 		<ul style="list-style-type: none"> 1/2 dir jets (full auth - MNA/MNB) All dir jets (1/2 auth or full auth - MNA) 	<ul style="list-style-type: none"> 1/2 dir jets (full auth - MNA/MNB)
Figure 6-6. AC/DC Bus Loss (G&C Effects) (Sheet 1 of 2)				

G&C OPERATIONS

5.1.1

NORMAL/BACKUP

APOLLO-SOYUZ TEST PROJECT (ASTP)
OPERATIONS HANDBOOK

G&C FUNCTIONS LOST OR MODIFIED				
BUS LOSS				
G&C COMPONENT	AC1	AC2	MNA	MNB
RHC 2		<ul style="list-style-type: none"> Rate cmd 	<ul style="list-style-type: none"> 1/2 dir jets (full auth - MNA/MNB) 	<ul style="list-style-type: none"> 1/2 dir jets (full auth - MNA/MNB) All dir jets (1/2 auth or full auth - MNB)
ECA	<ul style="list-style-type: none"> Min impulse Att hold Rate damping RHC 1 rate cmd SCS auto ΔV RHC 1 MIVC 	<ul style="list-style-type: none"> Rate cmd MIVC Att hold No BMAG 2 Auto ΔV rate 	<ul style="list-style-type: none"> Att hold No BMAG 1 Auto ΔV error 	<ul style="list-style-type: none"> Min impulse (42 msec)
GDC	<ul style="list-style-type: none"> R,P,Y att FDAI roll align 	<ul style="list-style-type: none"> R,P,Y att FDAI pitch, yaw align Roll stab att (RSI) 	<ul style="list-style-type: none"> R,P att 	<ul style="list-style-type: none"> Y att Roll stab att (RSI)
ORDEAL		<ul style="list-style-type: none"> Pitch (lcl horiz) att 		<ul style="list-style-type: none"> Pitch (lcl horiz) att
EDA (FDAI,GPI)	<ul style="list-style-type: none"> FDAI 1 (R,P,Y att, rate, error) GPI 1 (P,Y) 	<ul style="list-style-type: none"> FDAI 2 (R,P,Y att, rate, error) GPI 2 (P,Y) 	<ul style="list-style-type: none"> FDAI 1 (R,P,Y att) 	<ul style="list-style-type: none"> FDAI 2 (R,P,Y att)
RJEC (RCS)			<ul style="list-style-type: none"> Yaw dir ULL jets (D3/B4) CM RCS 1 auto jets (prior CM/SM sep) 	<ul style="list-style-type: none"> Pitch dir ULL jets (C3/A4) CM RCS 2 auto jets (prior CM/SM sep)
SPS			<ul style="list-style-type: none"> Bank A GMBL mot P1, Y1 	<ul style="list-style-type: none"> Bank B GMBL mot P2, Y2

Figure 6-6. AC/DC Bus Loss (G&C Effects) (Sheet 2 of 2)

G&C OPERATIONS

APOLLO-SOYUZ TEST PROJECT (ASTP)
OPERATIONS HANDBOOK

The G&C circuit breakers listed in this chart must be closed throughout the mission except when necessary to correct a malfunction.

Panel 8	Panel 5
SCS	G/N
TVC AC1	LTS (both)
AC (both)	IMU (2)
ECA/TVC AC2	IMU HTR (2)
CONTR DIR (4)	CMPTR (2)
A/C ROLL (2)	OPT (2)
B/D RCLL (2)	Panel 229
PITCH (2)	EPS
YAW (2)	GRP 1 (both)
CONTR AUTO (2)	GRP 2 (both)
LOGIC BUS 2/3 & 3/4	GRP 3 (both)
SYS (2)	GRP 4 (both)
ORDEAL (2)	GRP 5 (both)
RCS	
SM HTRS (4)	
PRPLNT ISCL (2)	
EMS (2)	
SPS (all except)	
Gauging (4)	

Figure 6-7. Limited Use G&C Circuit Breakers

6.1.1

G&C OPERATIONS

NORMAL BACKUP

APOLLO-SOYUZ TEST PROJECT (ASTP)
OPERATIONS HANDBOOK

Switch	Location	Position Major Portion of Mission	When Required	Remarks
GMC ATT	MDC-1	IMU	Normally not touched.	Selection of GDC position causes total attitude display to be lost on both balls. Must not be moved to GDC position if (1) pitch or yaw rate is >5°/sec, or (2) GDC yaw Euler angle is >80° and <280°. GDC damage will result if this is done.
IMU CAGE (guarded)	MDC-1	off (down)	To establish an inertial reference in event of CSS failure or IMU tumbling.	Cage mode zeros the IMU gimbals in a coarse alignment.
LMS ROLL	MDC-1	OFF	Prior to entry.	Refer to Entry and Entry Preparation procedures.
.05 G SW	MDC-1	OFF	At .05 G during entry.	Except for entry, on (up) position is not desirable (cages BMAGs). Off position powered by LOGIC 2/3 PWR - on (up).
Pc IND sw	MDC-1	Pc	Normally not touched	Left in Pc position during entire mission.
LV IND/GPI sw	MDC-1	GPI	Prior to SPS thrusting.	Placed in SIVB position during Prime Crew Prelaunch check. Temporarily placed in GPI position for SPS gimbal check during boost phase.

Figure 6-8. Limited Use Controls (Sheet 1 of 2)

G&C OPERATIONS

APOLLO-SOYUZ TEST PROJECT (ASTP)
OPERATIONS HANDBOOK

Switch	Location	Position Major Portion of Mission	When Required	Remarks
LV GUID	MDC-2	IU	If inputs to SIVB control system via CMC are required.	Nonfunctional after separation from SIVB.
UP TLM	LEB-122	ACPT	Not normally changed.	Both UP TLM switches (MDC-2, LEB 122) must be in ACPT position for CMC to accept telem data. MDC-2 switch is normally used as control.

Figure 6-8. Limited Use Controls (Sheet 2 of 2)

G&C OPERATIONS

6.1.1

APOLLO-SOYUZ TEST PROJECT (ASTP)
OPERATIONS HANDBOOK

9. ACCEL CMDs: Acceleration commands are available, via RHCs, any time MAN ATT switches are at ACCEL CMD (SC CONT - CMC or SCS). However, ACCEL CMD position inhibits any CMC outputs to RCS jets.
10. EMS MODE switch: EMS MODE switch should be placed to NORM <30 seconds prior to thrusting. Buildup of ΔV indicator errors, caused by accelerometer bias, minimized if this is done. Errors also minimized if set to STBY immediately after thrusting. Otherwise, ΔV ind continues counting.
11. MAN ATT/EMAG MODE switches: Switches may be set by axis, as desired.
12. SPS GMBL MOTORS: Start motors sequentially at ≈ 1 -second intervals to avoid electrical overload. Turn GMBL MOT switches OFF sequentially to avoid power surge. Turning servo 2 off first minimizes switching in the logic.
13. (R02) IMU STATUS check: Procedure prerequisites signify when ISS should be on and a known orientation required. Assuming that prerequisites have been complied with, program alarm for R02 should not occur. If prerequisites are not complied with, program alarm for ISS not on and/or IMU orientation unknown is treated as shown in 8.1.16.
14. CMC ATT switch: Normally left at IMU position throughout mission. Selection of GDC position causes total attitude display to be lost on both balls. GDC damage will result if GDC position selected and pitch or yaw rate is $>5^\circ/\text{sec}$, or if GDC yaw Euler angle is $>60^\circ$ and $<280^\circ$.
15. COAS: During COAS installation or removal, verify COAS PWR switch (panel 15) is OFF. If COAS reticle lamp power is lost, the crew penlight may be used for the reticle light source. Ensure that COAS PWR switch (panel 15) is OFF. Remove COAS light bulb; insert and tape penlight in receptacle. Dimming of the reticle may be achieved by tilting penlight away from the longitudinal axis of the COAS.
16. DIGITAL AUTOPILOTS (Docked and Undocked): The Docked RCS DAP (DDAP) will normally be activated (via V45E) only when CSM is docked to the Soyuz; otherwise Undocked RCS DAP (UDAP) will be activated (via V46F). Figure 6-12 describes Docked and Undocked functional differences and capabilities. R03 and R04 are the load routines used with the Undocked and Docked DAPS respectively.
17. COORDINATE SYSTEM: Figure 6-13 depicts the CSM/DM/SOYUZ cluster coordinate systems. Additionally, the rotations produced by various jet schemes are shown.

G&C OPERATIONS

6.1.2 SCS Operations

1. SCS RATE/DEADBAND: During SCS attitude control modes (4.7.1), ATT DBD and RATE switch positions establish rate and deadband response. (See figure 6-9.) For FDAI scaling, see figure 6-10. Refer to 8.2.1 for selection of CMC controlled rate and deadband.
2. SCS JET SEL: Sixteen AUTO RCS switches, consisting of four switch groups titled A/C ROLL, B/D ROLL, PITCH, and YAW with four switches each, enable CM and/or SM jets. Panel nomenclature for AUTO RCS switches summarizes jet characteristics for both SM and CM RCS jets. See figure 6-11. Refer to 6.1.3, note 1d, and 8.2.1 for CMC jet selection.
3. INADVERTENT JET FIRINGS: When powering up SCS, EMAGs should be caged to prevent inadvertent firings of RCS jets.
4. PSEUDO RATE: The pseudo rate function, controlled by LIM CYCLE switch, is used only during SCS attitude hold mode to conserve RCS propellants. However, manual SCS maneuvers with LIM CYCLE switch on cause excessive RCS injector valve cycling and increased propellant consumption. Switch does not function when in computer (CMC) mode. Also refer to note 6.
5. SIG CONDR/DR BIAS PWR switch: Powers RJEC -4 vdc bias power supplies and various SCS signal conditioners for telemetry. To provide increased reliability, switches should not be set on same bus.
6. LIM CYCLE switch: For SCS modes, LIM CYCLE switch should be configured as follows in order to conserve RCS propellant:
 - OFF - Manual proportional rate command.
 - OFF - Automatic rate damping.
 - on (up) - Attitude hold.
7. EMAG PWR switch: When EMAG PWR switches set to OFF, 40-minute warmup may be required (EMAG 1 & 2 TEMP lights out when operating temperature reached) for optimum operation of EMAGs. However, meaningful rate information is available immediately from cold EMAGs. If set from ON to WARMUP, EMAG TEMP lights should remain out.

6.1.2

SCS OPERATIONS

NORMAL BACKUP

APOLLO-SOYUZ TEST PROJECT (ASTP)
OPERATIONS HANDBOOK

8. RHC's (interchange): Interchanging of RHC No. 2 with RHC No. 1 to Support an Operational Failure of RHC No. 2 during Mission.
 - a. Remove RHC No. 1 and RHC No. 2 from couch armrests by releasing lock and pawl assembly.
 - b. Remove cable from six restraints on couch beam starting from controller end.
 - c. Loosen handle/clamp which secures couch to beam and disengage couch from clamp (R.H. and L.H. couch).
 - d. Remove cable from remaining restraints to connect on junction box.
 - e. Install RHC No. 1 to right hand armrest of commander's couch and secure with pawl and lock assembly.
 - f. Install RHC No. 2 to left hand armrest of communication couch and secure with pawl and lock assembly.
 - g. Route cable utilizing the eleven restraints on each beam and strut supports in configuration as removed.
 - h. Reinstall couch in clamp located on couch beam and secure with clamp/handle.
 - i. From strut establish a cable service loop approximately 10 inches in diameter atop wire tray and secure with tape as necessary.
9. RHC's (push-to-talk interchange): If the push to talk capability for the No. 1 RHC is desired, the connectors at the junction box must be interchanged since this function is not available electrically at the junction box for RHC No. 1 position. To implement this, the following procedure should be followed in addition to the above procedure for switching RHC's.
 - a. Remove RHC connector shroud covers (P1 and P2) attached to the SCE junction box using tool E (stowage item).
 - b. Select the off position of the normal and direct switches (2 each) on Panel No. 1 prior to demating connectors.
 - c. Disconnect both connectors and remate to opposite receptacles.
 - d. Reinstall connector covers using tool E.
 - e. Route cables along front side (+Z_c) of junction box shroud and secure both cables with strap provided.
 - f. Set direct and normal switches to on position.

SCS OPERATIONS

APOLLO-SOYUZ TEST PROJECT (ASTP)
OPERATIONS HANDBOOK

Control Parameter	SWITCH POSITIONS			
	RATE - LOW*		RATE - HIGH	
	ATT DBD:		ATT DBD:	
	MIN	MAX*	MIN	MAX
Attitude Deadband	+0.2°	+4.2°	+4.0°	+8.0°
Commanded Rates	Pitch & Yaw		+7.0°/sec	
	Roll		+20.0°/sec	
Rate Deadband	+0.2°/sec		+2.0°/sec	
*Recommended position to minimize fuel consumption during attitude hold.				

Figure 6-9. SCS Rate and Deadband Select Logic

SCS OPERATIONS

6.1.2

APOLLO-SOYUZ TEST PROJECT (ASTP)
OPERATIONS HANDBOOK

FDAI SCALE SW POS	FLIGHT PHASE	ATT ERROR		SCS RATES
		CMC	SCS	
		R 20° P&Y 5°	RP&Y 5°	
5/1	Boost & entry	RP&Y 5°	RP&Y 1°/sec	
	All other	RP&Y 5°	RP&Y 5°/sec	
5/5	Boost & entry	R 20° P&Y 5°	RP&Y 5°/sec	
	All other	RP&Y 5°	RP&Y 5°/sec	
50/15, 50/10	Boost & entry	R 50°	R 50°/sec	
		P&Y 15°	P&Y 10°/sec	
	All other	R 12.5°	R 50°/sec	
		P&Y 15°	P&Y 10°/sec	

Figure 6-10. FDAI Scaling

SCS OPERATIONS

APOLLO-SOYUZ TEST PROJECT (ASTP)
OPERATIONS HANDBOOK

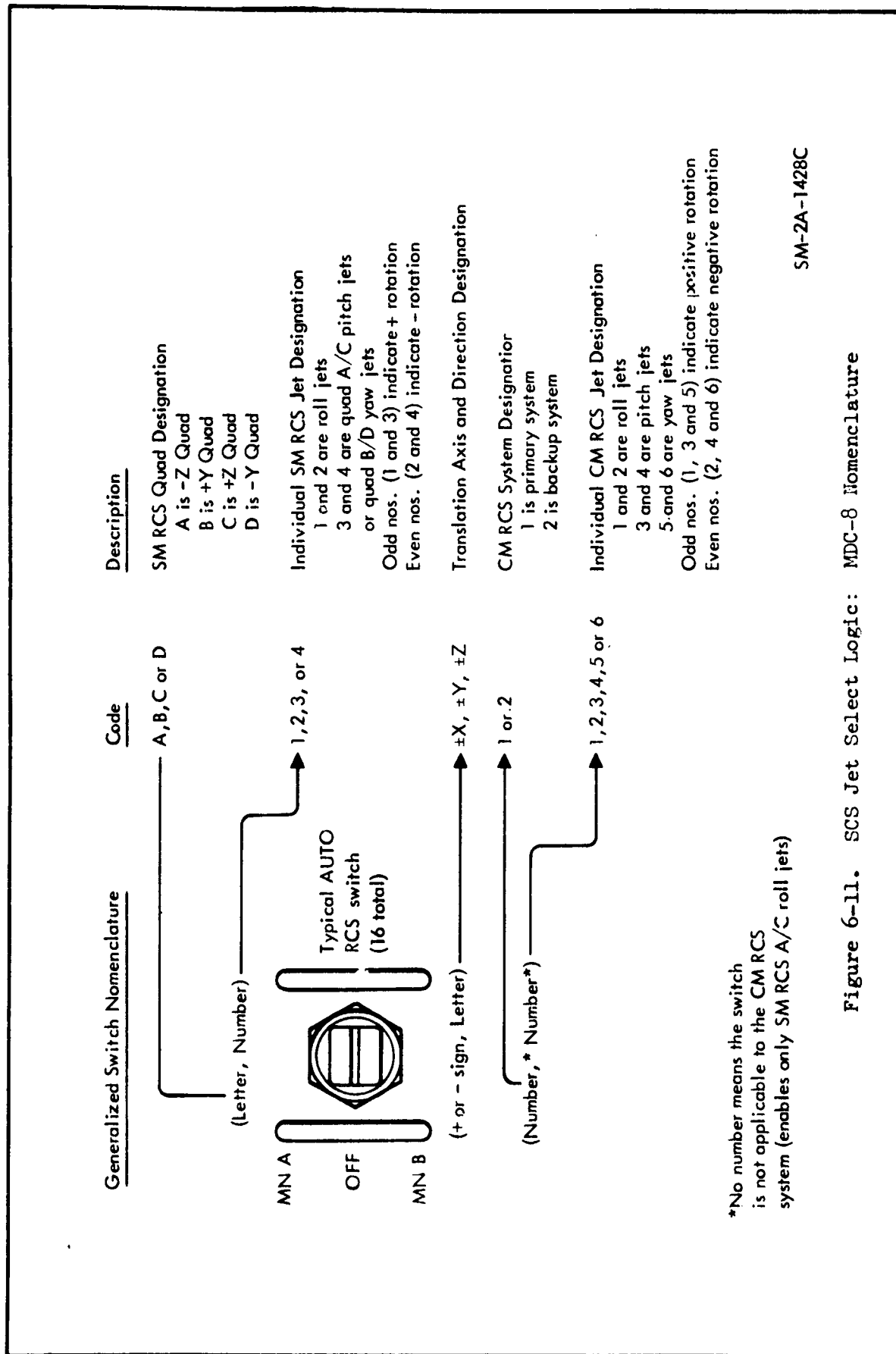

SM-2A-1428C

Figure 6-11. SCS Jet Select Logic: MDC-8 Nomenclature

SCS OPERATIONS

6.1.2

APOLLO-SOYUZ TEST PROJECT (ASTP)
OPERATIONS HANDBOOK

		MODES		
INPUTS		AUTO	HOLD	FREE
GENERAL		Accepts rate and attitude commands from maneuver routine.	<u>UDAP:</u> Holds attitude specified by N46. <u>DDAP:</u> Holds attitude specified by N89.	Free drift.
RHC		<u>UDAP:</u> Rate commands (magnitude specified by N46) about control axes. (Inhibits auto routine.) <u>DDAP:</u> Rate commands (magnitude specified by N89) about control axes. (Inhibits auto routine.)	<u>UDAP:</u> Rate commands (magnitude specified by N46) about control axes. <u>DDAP:</u> Rate commands (magnitude specified by N89) about control axes.	<u>UDAP:</u> Minimum impulse commands (14 ms jet firing). <u>DDAP:</u> Acceleration commands about control axes. For pitch and yaw axes, torque couple or force pair (N87-R1) determines jets to be used for commanded acceleration.
THC		<u>UDAP:</u> X, Y, Z commands combined with rotation commands result in X, Y, Z translation forces to S/C has priority over translation). <u>DDAP:</u> Only + & -X translation commands honored.	<u>UDAP:</u> X, Y, Z commands combined with rotation commands result in X, Y, Z translation forces to S/C (rotation has priority over translation). <u>DDAP:</u> Only + & -X translation commands honored.	X, Y, Z commands combined with rotation commands result in X, Y, Z translation forces to S/C (rotation has priority over translation). When docked to Soyuz, Y, Z commands actually result in rotation because of the moment arm between CSM quad plane and cluster c.g.
MIC		Ignored	Ignored	Minimum impulse commands <u>UDAP:</u> (14 ms jet firing). <u>DDAP:</u> (50 ms jet firing).

Figure 6-12. Digital Autopilots (Docked & Undocked)

SCS OPERATIONS

APOLLO-SOYUZ TEST PROJECT (ASTP)
OPERATIONS HANDBOOK

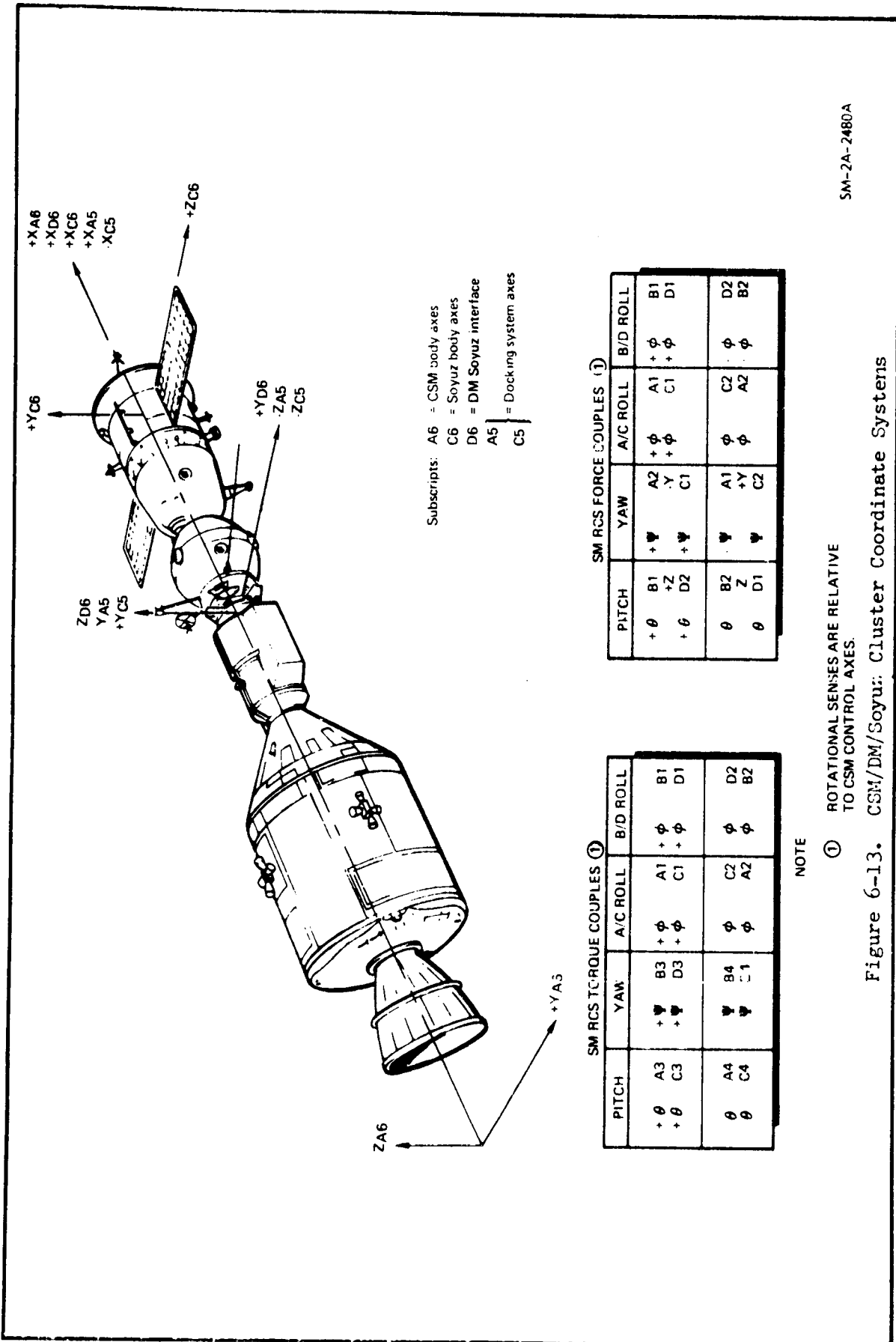

SM-2A-2480A

Figure 6-13. CSM/DM/Soyuz: Cluster Coordinate Systems

6.1.2

NORMAL BACKUP

APOLLO-SOYUZ TEST PROJECT (ASTP)
OPERATIONS HANDBOOK

6.1.1.3 G&N Operations

1. GENERAL:

- a. IMU STBY PWR: If standby power is removed for more than 20 minutes, ISS calibration is no longer valid.
- b. CMC CONTROLLED MANEUVERS: During CMC controlled maneuvers, any input from RHC (RHC out of detent) will be interpreted by CMC as a manual override and will cause immediate termination of auto maneuver calculation. During P20 if RHC is taken out of detent, V58E may be keyed to resume the CMC controlled maneuver.
- c. VEC POINT ROUTINE: VEC POINT routine (all CMC auto maneuvers except P20 options 4 and 5 and in R62) may compute large rotations about pointing vector when pointing vector must be rotated 180°. Sensitivity to such changes gets greater as magnitude increases toward 180°. If desired, a manual maneuver ($\approx 30^\circ$) may be performed and the solution is then recomputed by keying PRO on FL V50 N18 while not in CMC/AUTO.
- d. CMC JET SEL: CMC jet selection is accomplished by performing procedure 8.2.1, V43 (R03, DAP Data Load) or 8.2.2, V44 (R04, docked DAP Data Load). AUTO RCS switches should correspond to RCS DAP configuration.
- e. IMU GMBL LOCK: If non-G&N controlled attitude maneuvers are made by crew, care must be taken to avoid IMU gimbal lock. IMU gimbal angles may be monitored by observing ICDUs (V16 N20) or by monitoring FDAI ball. During CMC automatic maneuvers, if MGA $> 75^\circ$, CMC establishes attitude hold to prevent gimbal lock. Crew must manually maneuver, or provide more suitable IMU alignment.
- f. CMC PWR: If computer power is switched off, it will be necessary to perform a computer fresh start (V35E) to initialize erasable storage. CMC update program (P27) would have to be done to update the state vector and computer clock time.
- g. CLOCK TIME (GET): CMC is capable of maintaining an accurate value of ground elapsed time (GET) for only 23 hours when in standby mode. If CMC is not brought out of standby condition to running condition at least once within 23 hours, CMC value of GET must be updated.

G&N OPERATIONS

APOLLO-SOYUZ TEST PROJECT (ASTP)
OPERATIONS HANDBOOK

- h. IMU ORIENTATION (P51): Time and RCS prplnt may be saved, and subsequent IMU alignment decisions greatly simplified if P51 is performed in such a way as to leave IMU inertially stabilized at an orientation as close as possible to optimum orientation required by future CMC programs.
- i. UPLINK ACTY lt: Set when uplink (P27), or in R61 if R60 desired but maneuver inhibited. Reset when ERR RSET, KEY REL, or P27 termination.
2. CSS/ISS INTERFACE: Normally the CMC must be ON before the IMU can be operated. However, the IMU may be powered up while the CMC is at STBY. In this condition, the IMU is caged (if powered up) and remains in a coarse align mode. Caging is accomplished internally and does not require any panel switching. However, if the CMC is at STBY, the IMU can be uncaged by placing the IMU CAGE switch to on (up) for \approx 5 seconds. V37 should not be called for 15 seconds after NO ATT light goes out. If V37 is called prior to 15 seconds, the PIPA FAIL bit will not be reset and a PIPA FAIL will go undetected.
3. DSKY OPERATIONS: DSKY operations (MDC-2 and LEB-140) require certain restrictions to operation, loading of data, and display of data which are necessary to proper operation. Some general restrictions are listed below. Detailed information relative to DSKY operations is contained in MIT Report E-2129, "Keyboard and Display Program and Operation."
- a. DISPLAY/MONITOR VERBS: For display verbs (01-07), monitor verbs (11-17), and for all load verbs (21-25), the number of components of the verb must not exceed the number of components of the noun being used beginning with noun 04. Noun 01, 02, and 03 may be used with any verb regardless of number of components. If an attempt is made to violate this restriction, the OPR ERR indicator will illuminate when ENTR is pressed to execute the verb/noun action.
- b. OCTAL/DECIMAL MIXING: No mixing of octal and decimal data will be allowed for loads having more than one component. If an attempt is made to violate this restriction, the OPR ERR indicator will illuminate when ENTR is pressed for the last entry.
- c. DECIMAL/OCTAL LOADS: Octal data loads require only significant digits be keyed (e.g., 5, 4, ENTR). Loading decimal data requires each complete entry be made with a sign (+, -), followed by significant digits. Decimal load of less than 5 digits will be

6.1.3

G&N OPERATIONS

NORMAL BACKUP

APOLLO-SOYUZ TEST PROJECT (ASTP)
OPERATIONS HANDBOOK

accepted, just as an octal load. Zeros need not be entered ahead of most significant digit. (E.g., for a data load of +925, entry will be made by pressing DSKY keys +, 9, 2, 5, ENTR, and +, ENTR rather than +, 0, 0, 0, 0, 0, 0, ENTR.) When loading decimal data, ENTR sometimes changes last digit of loaded value.

- d. MACHINE ADDRESSES: Machine addresses must be loaded in octal.
- e. DATA LOAD: If an attempt is made to load a data word which is too large in magnitude for the noun being used, the CPR ERR indicator will illuminate.
- All data loads must be verified before pressing ENTR key for last register being loaded. (CLR key has no effect after last ENTR is pressed.) If any of the data is incorrect, register may be cleared by pressing CLR key. Each successive pressing of CLR key will clear preceding register until first register is cleared. (This backing up action will only operate on components called by load verb used.)
- f. VERB/NOU FLASHES: All VERB/NOU flashes require operator action and the program in progress is halted until appropriate action is taken.
- g. PROGRAM SELECTIONS: At times when program selection is not allowable by astronaut action (V37E XXE), ROO will issue a program alarm (01520) and interrupted activity will resume. Attempts to select nonexistent programs will result in an operator error light and return to interrupted program activity and display.
- h. PROGRAM TERMINATION: Any program can be terminated at a flashing display via V34E except:
- P20 (except to FL V06 N49 in R22 or to FL V50 N18 in R60) can be terminated by keying F00 or V56E only. V34E on a prethrust program will turn off that program but not P20.
 - V34E with an extended verb running will terminate the extended verb only.
 - V34E is ignored in P06, and for response relative to N61 in P62.

G&N OPERATIONS

APOLLO-SOYUZ TEST PROJECT (ASTP)
OPERATIONS HANDBOOK

STA/T STEP	PROCEDURE	PANEL	REMARKS
	<p>i. V96E: V96E may cause significant loss of W-matrix correlation if keyed in:</p> <ul style="list-style-type: none"> ● After a V37E XXE from a program using average G and before XX appears in PROG lights. ● During a permanent state vector integration in P20 during mark processing. <p>To recover, V93E is keyed at some time prior to next navigation marks or VHF range input. In all other cases, use of V96E will cause no ill effects providing next program selected is P00.</p>		<p>j. V82E: After V82E, meaningful information in N50 (splash error) is available only during P11 and P00.</p> <p>k. EXTENDED VERBS: Extended verbs are not restart-protected. If RESTART light goes on during an extended verb, or if software restart occurs (no RESTART light), the verb should be reselected.</p> <p>l. VG/AV DISPLAYS: VG or AV displays in control coordinates, N85 or N83, are based on reading accelerometers every 2 seconds. Displays, however, are asynchronous 1-second monitors. Result is a possible 1/2- to 1-1/2-second delay between application of AV and visible result.</p> <p>m. PRO KEY: A PRO key input is rejected if verb windows show a V21, V22, or V23. V33E must be used for these cases, e.g., a V21 PRO (or V25E PRO) will be rejected; a V25 PRO will not. For the V21, V22, V23 and PRO cases, PRO lights OPR ERR light.</p> <p>n. KEY REL pb/KEY REL lt: Normal and special cases of KEY REL light and KEY REL push-button use are discussed in the following notes.</p>

6.1.3

G&N OPERATIONS

NORMAL FACTOR

APOLLO SOYUZ TEST PROJECT (ASTP)
OPERATIONS HANDBOOK

STA/T STEP	PROCEDURE	PANEL	REMARKS
	<p><u>KEY REL lt - on</u></p> <ul style="list-style-type: none"> • When internal display comes up while operator has DSKY. • When internal flashing display is currently on DSKY and keystroke is made except for PRO, ENTR, and ERR RSET. • Suspended monitor: When operator makes keystroke on top of (his own) monitor verbs (verbs 11-17). • Remains on after V37 until new program is started. Operator should not use keyboard until KEY REL light is out and new program number is displayed. 		
	<p>c. <u>KEY REL lt - out</u></p> <ul style="list-style-type: none"> • When operator relinquishes DSKY by pressing KEY REL. • When operator terminates his current sequence normally by: <ul style="list-style-type: none"> Final ENTR of load sequence or ENTR, after a response to a flashing display (V34E) or ENTR, after an extended verb request (V49E). 		
	<p>p. <u>Special cases of KEY REL</u></p> <ul style="list-style-type: none"> • If operator selects a nonmonitor verb display on top of his own previously selected monitor verb, the KEY REL light will flash. Pressing KEY REL will bring back (unsuspend) the monitor and extinguish light. However, if these sequences are performed on top of an internal display, the KEY REL light will not go out when KEY REL is pressed. One more KEY REL operation (total of two) is required to extinguish KEY REL light, and bring back the internal display. 		

G&N OPERATIONS

● If operator selects a verb-noun combination (i.e., V16 monitor) on top of an internal flashing display, the internal display can still be answered with V32E, PRO, or V34E, which wipes everything from the DSKY until the next internal display. However, an operator-selected monitor should, as a rule, never be terminated with V34E. V34E may not be the desired response to the internal flashing display. KEY REL should be used instead. KEY REL need not be used if a data load is interrupted by a priority display.

- q. N58: N58 should not be loaded, although a data load may not generate OPR ERR.
- r. P20 (option 2): The following modes of suspension or termination have the effect shown:

MODE	EFFECT		
	DBD CENTERED	DBD SOURCE	RATES NULLED
RHC deflection	Yes	Unchanged	Yes
V56E	No	DAP (R03)	Yes
V37E OOE	No	DAP (R03)	Yes
SC CONT - SCS	Yes	SCS (Return to CMC re-establishes N79 DBD)	Yes (Return to CMC re-establishes N79 rate)
CMC MODE - FREE/AUTO	Yes	Unchanged	No
V46E	Yes	N79	No
CMC MODE - HOLD	Yes	N79	Poss jet firings
V48E, PRO	No	DAP (R03)	Poss jet firings (although not expected)
MGA > 75°	No	Unchanged	Yes

- s. PRIORITY DISPLAYS: There are three priority displays which will ignore any response for 2 seconds
 - V06 N49 in R22
 - V05 N09 in R52
 - V50 N18 in R60 (during P20)

G&N OPERATIONS

6.1.3

NORMAL BACKUP

APOLLO-SOYUZ TEST PROJECT (ASTP)
OPERATIONS HANDBOOK

4. OPTICS MECHANIZATION: Operation of the SCT and SXT requires adherence to certain constraints which are described as follows:
- a. To avoid sun interference, the sun position must be more than 10 degrees from optics shaft-drive axis and more than 15 degrees from star LOS for SXT, and more than 55 degrees from shaft-drive axis for SCT. Within these limits it is possible to use SXT even when sun position is between the SLOS and LLOS. The constraints given, however, do not take into account light scattering which can occur from actual spacecraft configuration.
 - b. An adequate portion of the star field must be visible through SCT in order that navigational stars can be recognized. The optics shaft-drive axis thus must be pointed at least 30 degrees above local sunlit earth horizon and at least 20 degrees above local dark earth horizon.
 - c. Maximum SXT LOS drive rates are 10 deg/sec for trunnion and 19.5 deg/sec for shaft, with a +20 percent tolerance.
 - d. TRACKER caution light should be ignored during TVC. Optics CDU fail during TVC, sets TRACKER light which will stay on (even with fail removed) until end of TVC or keying RSET.
 - e. During auto optics, computation lag between sampling IMU CDUs and driving optics causes optics to lag behind target. Amount of offset is proportional to CSM angular rate. This will not cause an error during manual tracking and marking.
 - f. After a fresh start, or restart, or after turning optics power on, optics must be taken out of zero and returned to zero to perform an optics zero since it is not position of switch but change to zero position that triggers zeroing program.
 - g. Optics may be damaged (when zeroing) by being driven into soft or hard stops if trunnion angle $>10^\circ$. To preclude possible damage, manually drive optics $<10^\circ$ before initiating zeroing procedure (refer to 8.1.4).

G&N OPERATIONS

APOLLO-SOYUZ TEST PROJECT (ASTP)
OPERATIONS HANDBOOK

STA/T STEP	PROCEDURE	PANEL	REMARKS
6.2	VERB LIST		
	Regular Verbs		
01	Disp oct compnt 1 (R1)		
02	Disp oct compnt 2 (R1)		
03	Disp oct compnt 3 (R1)		
04	Disp oct compnt 1, 2 (R1, R2)		
05	Disp oct compnt 1, 2, 3 (R1, R2, R3)		
06	Disp dec (R1 or R1, R2 or R1, R2, R3)		
07	Disp DP dec - test only (R1, R2)		
11	Mon oct compnt 1 (R1)		
12	Mon oct compnt 2 (R1)		
13	Mon oct compnt 3 (R1)		
14	Mon oct compnt 1, 2 (R1, R2)		
15	Mon oct compnt 1, 2, 3 (R1, R2, R3)		
16	Mon dec (R1 or R1, R2 or R1, R2, R3)		
17	Mon DP dec - test only (R1, R2)		
21	Load compnt 1 (R1)		
22	Load compnt 2 (R2)		
23	Load compnt 3 (R3)		
24	Load compnt 1, 2 (R1, R2)		
25	Load compnt 1, 2, 3 (R1, R2, R3)		
27	Disp fixed memory		
30	Request exec		
31	Request waitlist		
			V33E must be used for accept option if V21, V22, or V23 is in verb window. PFO is not accepted and turns on OPR ERR light.

VERB LIST

6.2

NORMAL BACKUP

APOLLO-SOYUZ TEST PROJECT (ASTP)
OPERATIONS HANDBOOK

STA/T STEP	PROCEDURE	PANEL	REMARKS
32	Recycle		
33	Proceed		
34	Terminate		
35	Test lights		
36	Req fresh strt		Use in P00 only. Blanks DSKY displays. May compromise stored state vector requiring a P27 update and IMU orientation determination.
37	Change prog (major mode)		
	Extended Verbs		
*40	Zero CDU		Ensures sync between ISS CDU counters and CDU counters in CMC. Terminates coarse align and enters fine align.
41	Coarse align CDU (with N20 & N91)		N20 - Aligns IMU to gimbal angles specified by crew. To coarse align to 0, 0, 0 when GMBL LOCK and coarse align. N91 - To drive optics to shaft and trunnion angles specified by crew (V41 N91 from P00 only).
42	Fine align IMU		Pulse torque gyros. P00 only.
43	Load FDAI att err needles (test only)		Calls routine R04. DDAP = Docked DAP.
44	Strt DDAP data load		
*45	Activate DDAP		UDAP = Undocked DAP.
*46	Activate UDAP		
*47	Set Soyuz state vctr into CSM state vctr		Calls routine R03. P00 only.
48	Strt UDAP data load		
49	Strt crew defined mnvr (R62)		
	*Callable with another extended verb in use & does not lock out other extended verbs.		

VER. LIST

APOLLO-SOYUZ TEST PROJECT (ASTP)
OPERATIONS HANDBOOK

STA/T STEP	PROCEDURE	PANEL	REMARKS
50	Please perform		
51	Please mrk		Used in P03, R53.
53	Please mrk alternate LOS		Used in R23, R56.
54	Strt rndz backup sighting mrk (R23)		
55	Increment CMC time (dec)		
*56	Term tracking (P20)		Both VHF and/or optics mark data.
57	Partial/full track option		Allows auto maneuvers.
*58	Rset stick flag, set V50M18 flag		Enables all jets previously inhibited in R04.
*59	Enable all jets		N17 = N20.
*60	Set att err ref to present att		
*61	Sel mode 1 (disp DAP att err)		Mode 1. FDAI error needles show difference between current and DAP commanded ICDU angles.
*62	Sel mode 2 (disp tot att err)		Mode 2. Display difference between desired final ICDUs (N22) and present ICDUs (N20) resolved into CSM control axes. (N22 -N20.)
*63	Sel mode 3 (disp tot astronaut att err)		Mode 3. Display difference between astronaut total attitude (N17) and present ICDUs (N20) resolved into CSM control axes. (N17 -N20.)
64	Req opt angle transform (R64)		V64E calls R64.
*65	Strt opt verif of prelaunch align - P03		V65E calls for P03 (during P02 only).
*66	Set CSM state vctr into Soyuz state vctr		
67	Strt w matrix RSS err disp		
*69	Restr		
	*Callable with another extended verb in use & does not lock out other extended verbs.		

VERB LIST

6.2

NORMAL BACKUP

APOLLO-SOYUZ TEST PROJECT (ASTP)
OPERATIONS HANDBOOK

STA/T STEP	PROCEDURE	PANEL	REMARKS
70	Strt CMC update - liftoff time (P27)		V70 through V73 are allowed only during P00, P02 or options 1, 2 and 5 of P20 (running alone).
71	Strt CMC update - block ADR (P27)		
72	Strt CMC update - single ADR (P27)		
73	Strt CMC update - CMC time (P27)		
*74	Init erasable dump via downlink		
*75	backup liftoff		
76	Enable R27 in R22		
*77	Disable R27 in R22		
*78	Update prelaunch az		Selected only during P02.
*80	enbl Soyuz state vctr update		
*81	enbl CSM state vctr update		
82	Req orb param disp (R30)		V82E calls R30.
83	Req rndz param disp #1 (R31)		V83E calls R31 (MINKEY controller initiates V63 for P37 call).
85	Req rndz param disp #2 (R34)		V85E calls R34.
*86	Reject rndz backup sighting mrk		
*87	Set VHF range flag		
*88	Rset VHF range flag		
89	Strt rndz fnl att routine (R63)		V89E calls R63 from P00 only.
90	Req rndz out of plane disp (R36)		V90E calls R36. P00 only.
91	Banksun		
*93	Enbl W matrix init		
*96	Term integration & go to P00.		
97	SPS thrust fail (R40)		
99	Enbl eng ign		
			*Callable with another extended verb in use & does not lock out other extended verbs.

VERB LIST

APOLLO-SOYUZ TEST PROJECT (ASTP)
OPERATIONS HANDBOOK

STA/T STEP	PROCEDURE	PANEL	REMARKS
6.3	NOUN LIST		
01	Specify address (fract)	.XXXX .XXXX .XXXX XXXX. XXXX. XXXX. XXX.XX XXX.XX XXX.XX XXX.XX DEG XXX.XX DEG XXX.XX DEG XXX.XX DEG XXX.XX DEG OCT OCT OCT OCT OCT OCT OCT OCT OCT OCT OCT OCT OCT OCT	All nouns may be loaded via DSKY entry. However, registers containing units of XXBXX cannot be loaded and nouns containing such register data cannot be loaded by V24 or V25.
02	Specify address (whole)		
03	Specify address (deg)		
04	Att error		This is a no load noun (OPR ERR).
+05	Sighting angle diff		
+06	Sighting angle		
+07	Option code ID		
	Option code		
	Flagword	ECADR BIT ID ACTION ADRES BBCON ERCOUNT FIRST SECOND LAST	ECADR \leq 30 (octal) will select appropriate channel (except that channel 7 attempts will be ignored).
08	Alarm data		
09	Alarm codes		
10	Chan to be specified		
	+Nouns not manually callable with valid data at any time.		

6.3

NOUN LIST

NORMAL/BACKUP

APOLLO-SOYUZ TEST PROJECT (ASTP)
OPERATIONS HANDBOOK

STA/T STEP	PROCEDURE	PANEL	REMARKS
11	GETI (NCC)	OOXX. HRS OOXX. MIN OXX.XX SEC OCT	Used only with extended verbs.
+12	Option code	OCT	
13	GETI (NSR)	OOXX. HRS OOXX. MIN OXX.XX SEC	Star tracker azimuth. Star tracker elevation. Used with N01, N02, and N03. Used by extended verb only. (See N24 for limitations.)
14	OGA (star tracker) IGA (star tracker)	XXXX. ARC MIN XXXX. ARC MIN	
15	Increment address	OCT	Used in Mode 3 needles (V63).
+16	Time of event	OOXX. HRS OOXX. MIN OXX.XX SEC	
17	Astronaut tot att	XXX.XX DEG XXX.XX DEG XXX.XX DEG XXX.XX DEG XXX.XX DEG XXX.XX DEG	Star tracker azimuth. Present angles.
18	Auto mnvr	OG-R IG-P MG-Y X Y Z	
19	OGA (star tracker)	OCT	Star tracker azimuth. Present angles.
20	ICDU angles	XXX.XX DEG XXX.XX DEG XXX.XX DEG	
21	PIPAS	XXXX. Pulses XXXX. Pulses XXXX. Pulses	
+Nouns not manually callable with valid data at any time.			

NOUN LIST

APOLLO-SOYUZ TEST PROJECT (ASTP)
OPERATIONS HANDBOOK

STA/T STEP	PROCEDURE	PANEL	REMARKS
22	New ICDU angles OG-R IG-P MG-Y	XXX.XX DEG XXX.XX DEG XXX.XX DEG XXX.XX DEG XXX.XX DEG XXX.XX DEG XXX.XX DEG 00000. HRS	Euler angles. (May apply to Soyuz coord. sys.)
23	NB to ATM angles	00000. MIN 00000. SEC XXXXX.	V25 N24 display initiated by V55E. (Max time = 745 hrs, 39 min, 14.55 sec.)
+24	Δ time for CMC clock	00000. MIN 00000. SEC XXXXX.	Used with V50. (Refer to checklist codes, 6.5.) Used with V30, V31.
+25	Checklist	OCT	
26	Prio/delay ADRES BBCON	OCT OCT OCT	
27	Self-test on/off sw	XXXXX. HRS	
28	GETI (NC2)	00000. MIN 00000. SEC XXX.XX DEG	Xsm - X stable member.
+29	Xsm launch az	XXXXX.	
+30	Trgt code (gyro com- passing verif)	XXXXX. XXXXX.	
31	Time of RNDZ W-matrix last r/v initialization	00000. HRS 00000. MIN 00000. SEC	Time from perigee. (See N24 for limitations.)
32	TF perigee	00000. HRS 00000. MIN 00000. SEC	GETI - ground elapsed time of ignition. (See N24 for limitations.)
33	GETI	00000. HRS 00000. MIN 00000. SEC	
	+Nouns not manually callable with valid data at any time.		

NOUN LIST

NORMAL BACKUP

APOLLO-SOYUZ TEST PROJECT (ASTP)
OPERATIONS HANDBOOK

STA/T STEP	PROCEDURE	PANEL	REMARKS
+34	Time of evnt	OOXX. HRS OOXX. MIN OX.XX SEC	GET. (See N24 for limitations.)
35	Time from evnt	OOXX. HRS OOXX. MIN OX.XX SEC	GET. (See N24 for limitations.)
36	Time of CMC clock	OOXX. HRS OOXX. MIN OX.XX SEC	See N24 for limitations.
37	GETI (TPI)	OOXX. HRS OOXX. MIN OX.XX SEC	See N24 for limitations.
38	Time of state vctr	OOXX. HRS O(OXX. MIN OX.XX SEC	Time of last maneuver (P38). (See N24 for limitations.)
39	GETI (last mnvr)	OOXX. HRS OOXX. MIN OX.XX SEC	This is a no load noun (OPR ERR). Velocity to be gained (counts down). Velocity gained this burn. N41 - 2 component noun.
40	TF GETI/TFC VG ΔV (accum)	XXBX MIN-SEC XXX.X FPS XXX.X FPS XX.XX DEG X.XXX DEG	Apogee altitude. Perigee altitude.
+41	Trgt AZ Elev	XXX.X NM XXX.X NM XXX.X FPS XXX.XX DEG XXX.XX DEG XXX.X NM	
42	Ha Hp ΔV (req) Lat (+N) Long (+E) Alt		
43			
	+Nouns not manually callable with valid data at any time.		

NOUN LIST

APOLLO-SOYUZ TEST PROJECT (ASTP)
OPERATIONS HANDBOOK

STA/T STEP	PROCEDURE	PANEL	REMARKS
44	Ha Hp TFF	XXXX.X NM XXXX.X NM XXBXX MIN-SEC	Apogee altitude. This is a no load noun (OPR ERR). Perigee altitude. Time of freefall to 49.4 NM (300,000 ft) above launch pad radius.
45	Mks (VHF/opt) TF GETI (next burn) MGA DAP config (R03)	XXBXX MKS XXBXX MIN-SEC XXX.XX DEG OCT OCT	This is a no load noun (OPR ERR). Undocked DAP.
47	CSM wt LM wt	XXXXX. LB XXXXX. LB	Undocked DAP Undocked DAP. LM wt not normally used for ASTP.
48	Pitch trim Yaw trim	XXX.XX DEG XXX.XX DEG	Loads gimbal pitch and yaw trim angles.
49	ΔR ΔV	XXX.XX NM XXX.X FPS	
50	Code (VHF/opt): Splash err	0000X. XXX.X NM	Negative for undershoot, positive for overshoot. This is a no load noun (OPR ERR).
52	Hp TFF	XXXX.X NM XXBXX MIN-SEC	Time of freefall.
53	CENTANG (CSM) R R dot	XXX.XX DEG XXX.XX NM XXX.X FPS	Central angle of CSM. Range calculated from state vector. Range rate calculated from state vector.
54	Phi (lcl horiz/SLOS) R R dot θ (lcl horiz/CSM +X)	XXX.XX DEG XXX.XX NM XXX.X FPS XXX.XX DEG	0 to 180° = SLOS above plane. Range calculated from state vector. Range rate calculated from state vector. 0 to 180° = +X above plane.

NOUN LIST

6.3

NORMAL BACKUP

APOLLO-SOYUZ TEST PROJECT (ASTP)
OPERATIONS HANDBOOK

STA/T STEP	PROCEDURE	PANEL	REMARKS
55	NM	0000.	Display definition depends on using program/routine. Elevation. This is a no load noun (OPR ERR).
56	E Veh rate	XXX.XX DEG X.XXXX DEG/SEC X.XXXX DEG/SEC X.XXXX DEG/SEC XXXXX. XXXX.X NM XXXX.X NM XXXX.X FPS XXXX.X FPS XXXX.X FPS XXXXX MIN-SEC XXXX.X FPS XXXX.X FPS XXXX.X FPS XXX.XX G XXXXX. FPS XXX.XX DEG XXX.XX DEG XXX.XX DEG +/-00001. XXXXX. FPS XXXXX. FPS XXXXX.X NM XXXX.X NM	
57	1/2 revs ΔH (NCC)		
58	ΔM (NSR) ΔV (TPI) ΔV (TPF)		
59	ΔT (TPI -TPI nom) ΔVX (LOS) ΔVY (LOS) ΔVZ (LOS)		
60	G max V pred Gamma EI [lcl horiz/VI (+up)]		
61	Impact Lat (+N) Impact Long (+E) Hds up/down (+Hds up)		
62	VI H dot H pad		Inertial velocity. Altitude rate. Altitude above pad radius.
63	RTOGO (.05 G to splash)		One shot display, should always be positive. .05 G represents pad loaded altitude. This is a no load noun (OPR ERR).
	VIO (at .05 G) TFE (time from .05 G)	XXXXX. FPS XXBXX MIN-SEC	Predicted inertial velocity.

NOUN LIST

APOLLO-SOYUZ TEST PROJECT (ASTP)
OPERATIONS HANDBOOK

STA/T STEP	PROCEDURE	PANEL	REMARKS
64	Drag accel VI	XXX.XX G XXXXX. FPS	Inertial velocity.
	Range to splash	XXXXX.X NM	Negative and counting down when approaching target; positive and counting up when leaving target.
65	Sampled CMC time	0000X. HRS 0000X. MIN 0XX.XX SEC XXX.XX DEG	Fetches in interrupt.
66	Beta	XXXX.X NM	Commanded bank angle.
	CRSRNG ERR	XXXX.X NM	Positive to right of plane (LATANG +South); negative to left of plane (-North).
	DWRNG ERR	XXXX.X NM	Negative for undershoot (PREDANGLE -θ); positive for overshoot.
67	Range to splash	XXXX.X NM	Negative counting down for approaching target; positive counting up for leaving target.
68	Lat [Present pos (+N)] Long [Present pos (+E)] Beta	XXX.XX DEG XXX.XX DEG XXX.XX DEG	Commanded bank angle.
	VI	XXXXX. FPS	Inertial velocity.
	H dot	XXXXX. FPS	Altitude rate.
69	Beta	XXX.XX DEG	Beta - commanded bank angle.
	DL	XXX.XX G	DL - drag acceleration at end of up-control.
	VL	XXXXX. FPS	VL - velocity at end of up-control.
70	Trgt code (before mrk)	OCT	Sensor/star code.
71	Trgt code (after mrk)	OCT	Sensor/star code.

NOUN LIST

6.3

NORMAL BACKUP

APOLLO-SOYUZ TEST PROJECT (ASTP)
OPERATIONS HANDBOOK

STA/T STEP	PROCEDURE	PANEL	REMARKS
72	Time of R27 optim	OOXX. HRS OOXX. MIN OX.XX SEC XXXXX. NM XXXXX. FPS XX.XX DEG XX.XX DEG XXXX. FPS XX.XX G XXXX.X NM XXBX MIN-SEC XXBX MIN-SEC XX.XX NM XXXX.X FPS XXBX MIN-SEC XX.XX NM XXXX.X FPS XX.XX DEG XX.XX DEG XX.XX DEG XX.XX DEG X.XXXX DEG/SEC XX.XX DEG XXBX MIN-SEC XXXX. FPS XXXX. FPS XXXX.X FPS XXXX.X FPS XXXX.X FPS	Time of R27 optimization. On call in P21.
73	Alt/10 VI		
74	Gamma Beta VI		
75	Drag accel Δ alt (NSR)		
76	Δ T (TPI -NSR) Δ T (TPI -nom TPI) VHF R VHF R dot		Current R27 values (R22, P25, P48).
77	Time from R27 optim VHF R VHF R dot θ/ϕ		Optimized R27 values (R22, P25, P48). R27 θ/ϕ . (ϕ in R22, θ in P48). P20 yaw angle. P20 pitch angle. P20 azimuth constraint. P20 (option 2) rotation rate. P20 maneuver deadband.
78	Y (γ) P (ρ)		
79	Az Rate DBD		
80	TF GETI/TFC VG		
51	Δ V (accum) Δ VX (1cl vert) Δ Y (1cl vert) Δ VZ (1cl vert)		(Δ V components).

NCUN LIST

APOLLO-SOYUZ TEST PROJECT (ASTP)
OPERATIONS HANDBOOK

STA/T STEP	PROCEDURE	PANEL	REMARKS
82	VGX (NSR) VGY (NSR) VGZ (NSR)	XXXX.X FPS XXXX.X FPS XXXX.X FPS	(ΔV components) control = CSM control axes.
83	ΔVX (cont) ΔVY (cont) ΔVZ (cont)	XXXX.X FPS XXXX.X FPS XXXX.X FPS	
84	VG (next mnvr) ΔH (next mnvr) VG (3rd mnvr)	XXXX.X FPS XXXX.X NM XXXX.X FPS	
85	VGX (cont) VGY (cont) VGZ (cont)	XXXX.X FPS XXXX.X FPS XXXX.X FPS	(VG vector components) control = CSM control axes.
86	ΔVX (lcl vert) ΔVY (lcl vert) ΔVZ (lcl vert)	XXXXX. FPS XXXXX. FPS XXXXX. FPS	
87	DAP config (R04)	OCT OCT OCT	
88	Planet	X .XXXX Y .XXXX Z .XXXX	Docked DAP.
89	DAP rate DAP DBD	X.XXXX DEG/SEC XXX.XX DEG	Docked DAP.
90	Rndz out of plane param	Y CSM Y DOT(CSM) Y DOT(Soyuz)	Active vehicle. Active vehicle. Passive vehicle.
91	Present OCDU angles	Shft Trun	
92	New OCDU angles	Shft Trun	

NOUN LIST

6.3

NORMAL BACKUP

APOLLO-SOYUZ TEST PROJECT (ASTP)
OPERATIONS HANDBOOK

STA/T STEP	PROCEDURE	PANEL	REMARKS
93	Δ Gyro angles	X Gyro Y Gyro Z Gyro	XX.XXX DEG XX.XXX DEG XX.XXX DEG
94	Alternate LOS	Shft	XXX.XX DEG
95	GETI (NCL)	Trun	XX.XXX DEG
96	Rndz out of plane param	Y (CSM) Y Dot(CSM) Y Dot(Soyuz)	O000X. HRS O000X. MIN OXX.XX SEC XXX.XX NM XXXX.X FPS XXXX.X FPS
+97	Sys test inputs	XXXXX.	XXXXX.
+98	Sys test results and inputs	XXXXX. .XXXXX	XXXXX.
99	POS ERR VEL ERR Option code	XXXXX. FT XXXX.X FPS O000X	RSS value of position error. RSS value of velocity error. Option code (initially C0000). O0000 - No initialization O0001 - RNDZ (W-matrix initialization)
+Mouns not manually callable with valid data at any time.			

NOUN LIST

APOLLO-SOYUZ TEST PROJECT (ASTP)
OPERATIONS HANDBOOK

STA/T STEP	PROCEDURE	PANEL	REMARKS					
6.4	STAR LIST		Vis Mag, Right Ascension and Declination data are in sequence with the numerical list.					
NO.	STAR NAME (Numerical)	STAR NAME (Alphabetical)	NO.	Vis Mag	Right Ascension (hr) (min) (sec)	Declination (deg) (min) (sec)		
1	Alpheratz	(α And)	6	2.1	05 48.1	+28 48	48.5	
2	Diphda	(β Cet)	4	2.2	41 05.2	-18 15	37.9	
3	Savi	(γ Cas)	25	2.8	53 40.4	+60 26	47.4	
4	Achernar	(α Eri)	11	0.6	35 51.6	-57 29	25.6	
5	Polaris	(α UMi)	27	2.1	48 52.9	+89 01	43.6	
6	Acamar	(θ Eri)	21	3.4	56 21.8	-40 30	14.6	
7	Menkar	(α Cet)	32	2.8	39.7	+03 53	39.4	
10	Mirfak	(α Per)	1	1.9	44.5	+49 41	05.6	
11	Aldebaran	(α Tau)	40	1.0	03.0	+16 24	33.2	
12	Rigel	(β Ori)	33	0.3	08.0	-08 15	28.7	
13	Capella	(α Aur)	31	0.2	59.6	+45 56	48.3	
14	Canopus	(α Car)	34	-0.8	50.6	-52 40	02.9	
15	Sirius	(α CMa)	14	-1.5	55.6	-16 39	15.7	
16	Procyon	(α CMi)	13	0.4	40.1	+05 20	53.0	
17	Regor	(γ^2 Vel)	41	1.9	59.5	-47 11	18.2	
20	Dnoces	(ι UMa)	43	3.1	46.6	+48 14	16.6	
21	Alphard	(α Hya)	23	2.1	7.8	-08 26	26.5	
22	Regulus	(α Leo)	2	1.3	42.3	+12 12	44.5	
23	Denebola	(β Lec)	20	2.2	29.8	+14 51	03.1	
24	Gienah	(γ Crv)	44	2.7	13.6	-17 15	51.1	
25	AcruX	(α^1 Cru)	45	1.5	48.0	-62 49	19.5	
26	Spica	(α Vir)	24	1.2	33.2	-10 54	04.1	
27	Alkaid	(η UMa)	7	1.9	34.0	+49 33	43.5	

STAR LIST

6.4

NORMAL/BACKUP

APOLLO-SOYUZ TEST PROJECT (ASTP)
OPERATIONS HANDBOOK

STA/T STEP		PROCEDURE		PANEL	REMARKS					
NO.	STAR NAME (Numerical)	STAR NAME (Alphabetical)	NO.	Vis Mag	Right Ascension (hr)	(min)	(sec)	(deg)	Declination (min)	(sec)
30	Menkent	(θ Cen)	30	2.2	14	03	42.9	-36	07	41.7
31	Arcturus	(α Boo)	10	0.2	14	13	21.0	+19	25	45.0
32	Alphecca	(α CrB)	3	2.3	15	32	34.4	+26	52	52.7
33	Antares	(α Sco)	37	1.2	16	26	20.2	-26	19	22.5
34	Atria	(α Tra)	42	1.8	16	43	21.2	-68	56	20.7
35	Rasalhague	(α Oph)	5	2.1	17	32	36.9	+12	35	36.7
36	Vega	(α Lyr)	16	0.1	18	35	15.0	+38	44	16.2
37	Nunki	(σ Sgr)	35	2.1	18	52	10.0	-26	21	39.5
40	Altair	(α Aql)	17	0.8	19	48	21.4	+08	44	14.6
41	Dabih	(β Cap)	22	3.2	20	18	12.3	-14	56	26.5
42	Peacock	(α Pav)	12	2.1	20	21	42.3	-56	53	52.0
43	Deneb	(α Cyg)	15	1.3	20	39	43.5	+45	06	03.2
44	Enif	(ε Peg)	26	2.5	21	41	43.8	+09	38	41.8
45	Fomalhaut	(α PSA)	36	1.2	22	54	54.1	-29	53	19.5

STAR LIST

APOLLO-SOYUZ TEST PROJECT (ASTP)
OPERATIONS HANDBOOK

STA/T STEP	PROCEDURE	PANEL	REMARKS																													
6.5	CHECKLIST REFERENCE CODES (V50 N25)																															
	<table border="0"> <thead> <tr> <th data-bbox="407 404 460 513"><u>RI Code</u></th> <th data-bbox="407 513 460 709"><u>ACTION</u></th> <th data-bbox="407 709 460 1146"><u>FUNCTION</u></th> </tr> </thead> <tbody> <tr> <td data-bbox="460 273 513 404">00013</td> <td data-bbox="460 404 513 513">Perform</td> <td data-bbox="460 513 513 709">Coarse align or pulse torque</td> </tr> <tr> <td data-bbox="513 273 566 404">00014</td> <td data-bbox="513 404 566 513">Perform</td> <td data-bbox="513 513 566 709">Fine align option</td> </tr> <tr> <td data-bbox="566 273 619 404">00015</td> <td data-bbox="566 404 619 513">Perform</td> <td data-bbox="566 513 619 709">Trgt acq</td> </tr> <tr> <td data-bbox="619 273 672 404">00016</td> <td data-bbox="619 404 672 513">Key in</td> <td data-bbox="619 513 672 709">Term mrk seq</td> </tr> <tr> <td data-bbox="672 273 725 404">00017</td> <td data-bbox="672 404 725 513">Perform</td> <td data-bbox="672 513 725 709">MINKEY Rndz (displayed if REFSMFLG = 1)</td> </tr> <tr> <td data-bbox="725 273 777 404">00020</td> <td data-bbox="725 404 777 513">Perform</td> <td data-bbox="725 513 777 709">MINKEY NPC torquing</td> </tr> <tr> <td data-bbox="777 273 830 404">00041</td> <td data-bbox="777 404 830 513">Sw</td> <td data-bbox="777 513 830 709">CM/SM sep to up</td> </tr> <tr> <td data-bbox="830 273 883 404">00062</td> <td data-bbox="830 404 883 513">Key in</td> <td data-bbox="830 513 883 709">CMC pwr down</td> </tr> <tr> <td data-bbox="883 273 936 404">00204</td> <td data-bbox="883 404 936 513">Perform</td> <td data-bbox="883 513 936 709">Enbl gmb1 trim option</td> </tr> </tbody> </table>	<u>RI Code</u>	<u>ACTION</u>	<u>FUNCTION</u>	00013	Perform	Coarse align or pulse torque	00014	Perform	Fine align option	00015	Perform	Trgt acq	00016	Key in	Term mrk seq	00017	Perform	MINKEY Rndz (displayed if REFSMFLG = 1)	00020	Perform	MINKEY NPC torquing	00041	Sw	CM/SM sep to up	00062	Key in	CMC pwr down	00204	Perform	Enbl gmb1 trim option	<p>Target (celestial body) acquisition - Used in conjunction with N70, N71 and the following celestial body codes:</p> <ul style="list-style-type: none"> 00 - Planet (any planet except Earth) 01 to 45 - Star 46 - Sun 47 - Earth <p>Initiated when targeting programs P31 through P38 called by V37.</p> <p>Occurs in P52 during MINKEY plane change sequence.</p>
<u>RI Code</u>	<u>ACTION</u>	<u>FUNCTION</u>																														
00013	Perform	Coarse align or pulse torque																														
00014	Perform	Fine align option																														
00015	Perform	Trgt acq																														
00016	Key in	Term mrk seq																														
00017	Perform	MINKEY Rndz (displayed if REFSMFLG = 1)																														
00020	Perform	MINKEY NPC torquing																														
00041	Sw	CM/SM sep to up																														
00062	Key in	CMC pwr down																														
00204	Perform	Enbl gmb1 trim option																														

CHECKLIST REFERENCE CODES (V50 N25)

6.5

NORMAL BACKUP

APOLLO-SOYUZ TEST PROJECT (ASTP)
OPERATIONS HANDBOOK

STA/T STEP	PROCEDURE	PANEL	REMARKS																	
6.6	OPTION CODES (V04 N06 or V04 N12)																			
	<table border="0"> <thead> <tr> <th data-bbox="301 378 324 482"><u>R1 Code</u></th> <th data-bbox="301 482 324 586"><u>Purpose</u></th> <th data-bbox="301 586 324 703"><u>Input for R2</u></th> </tr> </thead> <tbody> <tr> <td data-bbox="324 378 347 482">00001</td> <td data-bbox="324 482 347 586">Specify IMU orientation</td> <td data-bbox="324 586 347 703"> 1 = PREF 2 = NOM 3 = REFSMMAT </td> </tr> <tr> <td data-bbox="347 378 370 482">00002</td> <td data-bbox="347 482 370 586">Specify veh</td> <td data-bbox="347 586 370 703"> 1 = CSM 2 = Soyuz </td> </tr> <tr> <td data-bbox="370 378 393 482">00004</td> <td data-bbox="370 482 393 586">Specify state of tracking (FULTKFLG)</td> <td data-bbox="370 586 393 703"> 0 = Full track 1 = Partial track </td> </tr> <tr> <td data-bbox="393 378 416 482">00012</td> <td data-bbox="393 482 416 586">Specify P50 option</td> <td data-bbox="393 586 416 703"> 1 = Sun sensor 2 = Sun sensor & star tracker 3 = Angles from independent source </td> </tr> <tr> <td data-bbox="416 378 439 482">00013</td> <td data-bbox="416 482 439 586">Specify P55 option</td> <td data-bbox="416 586 439 703"> 1 = Celestial body & IMU orient 2 = Celestial body, opt mark & Soyuz solar inertial att </td> </tr> </tbody> </table>	<u>R1 Code</u>	<u>Purpose</u>	<u>Input for R2</u>	00001	Specify IMU orientation	1 = PREF 2 = NOM 3 = REFSMMAT	00002	Specify veh	1 = CSM 2 = Soyuz	00004	Specify state of tracking (FULTKFLG)	0 = Full track 1 = Partial track	00012	Specify P50 option	1 = Sun sensor 2 = Sun sensor & star tracker 3 = Angles from independent source	00013	Specify P55 option	1 = Celestial body & IMU orient 2 = Celestial body, opt mark & Soyuz solar inertial att	<p>Specified option codes will be displayed in R1 in conjunction with V04 N06 or V04 N12. Requests desired option be loaded into R2.</p> <p>P20, VHF and optics marks. P20, VHF or optics marks.</p>
<u>R1 Code</u>	<u>Purpose</u>	<u>Input for R2</u>																		
00001	Specify IMU orientation	1 = PREF 2 = NOM 3 = REFSMMAT																		
00002	Specify veh	1 = CSM 2 = Soyuz																		
00004	Specify state of tracking (FULTKFLG)	0 = Full track 1 = Partial track																		
00012	Specify P50 option	1 = Sun sensor 2 = Sun sensor & star tracker 3 = Angles from independent source																		
00013	Specify P55 option	1 = Celestial body & IMU orient 2 = Celestial body, opt mark & Soyuz solar inertial att																		

OPTION CODES (V04 N06 OR V04 N12)

APOLLO-SOYUZ TEST PROJECT (ASTP)
OPERATIONS HANDBOOK

STA/T STEP	PROCEDURE	PANEL	REMARKS
R1 Code 00024	<u>Purpose</u> Specify tracking option	<u>Input for R2</u> 0 = Rndz (VECPPOINT) 1 = Celestial body (VECPPOINT) 2 = Rotation 4 = Rndz (3-axis) 5 = Celestial body (3-axis)	P20.

6.6

OPTION CODES (V04 N06 OR V04 N12)

NORMAL BACKUP

APOLLO-SOYUZ TEST PROJECT (ASTP)
OPERATIONS HANDBOOK

STA/T STEP	PROCEDURE	PANEL	REMARKS
6.7	<p>ALARM CODES (V05 N09)</p> <p>Codes are listed numerically by the four least significant digits. Codes beginning with 2 or 3 signify the following:</p> <p>Codes starting with 2 signifies POODOO routine: generates software restart (if ave G running or display type extended verb active, same as BAILOUT; if not, goes to ROO). Will not turn on RESTART lt</p> <p>Codes starting with 3 signifies BAILOUT routine: generates software restart (returns to interrupted program). Does not turn on RESTART lt</p>		<p>Alarms for V05 N09 (ERR RSET zeros R1 and R2; leaves R3 alone)</p> <p>R1 - first alarm to occur R2 - second alarm to occur R3 - last alarm to occur (There is no indication as to whether 3 or more than 3, alarms have occurred)</p> <p>The following list shows general numbering logic for alarm codes excluding interface and exceptions:</p>
			<p>00100-00200 Optics subsystem 00200-00300 IMU subsystem 00400-00600 Rendezvous 01100-01200 Computer hardware malfunctions 01200-01300 List overflows (all aborts) 01300-01400 Interpreter errors 01400-01500 Display alarms 01500-01600 Keyboard and display programs 01600-01700 System test alarms 01700-01800 DAP display alarms</p>
	00107 Star tracker angles out of limits		P55.
	00110 Mrk reject has been entered but ignored (continue)		Either no marks have been received or there have been no marks since last mark reject.
	00113 No chan 16 inbits (continue)		If alarm recurs, use MDC DSKY.

ALARM CODES (V05 N09)

APOLLO-SOYUZ TEST PROJECT (ASTP)
OPERATIONS HANDBOOK

STA/T STEP	PROCEDURE	PANEL	REMARKS
00114	More mrks made than desired (continue)		
00115	V41 N91 keyed with OPT MODE not in CMC		Set OPT MODE - CMC and OPT ZERO - OFF. OPR ERR also lights.
00116	Opt sw altered before 15 sec zero time elapsed		Set OPT ZERO - ZERO (≈15 sec to zero).
00117	V41 N91 keyed but CMC has reserved OCDU		V41 N91 not yet available. May occur from start of drive test until end of burn. (not expected since V41 N91 is restricted to P00).
00120	Opt torque has been req but opt have not been zeroed since last FRESH START or RESTART		Set OPT ZERO - OFF then ZERO (≈15 sec to zero).
00121	SC att rates of > two-thirds deg per sec will result in auto reject of sighting mrks		Repeat mark.
00205	PIPA saturated		Use SCS control. Refer to G&N malfunction procedures, symptom 12. While thrusting navigation (average G) is operating, a PIPA output in excess of 6399 pulses in a 2-second period has been detected.
00206	IMU zero routine has been entered with both GMBL LOCK lt and NO ATT lt on		Coarse align to 0, 0, 0. Reselect V40E. IMU mode switching.
00207	ISS turn-on req not present for 90 sec		Redo IMU turn on. Refer to G&N malfunction procedures, symptom 12.
00210	ISS not on		Redo IMU turn on. If alarm recurs, perform fresh start (V36E). Consult STDN. Refer to malfunction procedures, symptom 12. Used by IMU zero routine, R02, P51, and P53.

6.7

ALARM CODES (V05 N09)

NORMAL BACKUP

APOLLO-SOYUZ TEST PROJECT (ASTP)
OPERATIONS HANDBOOK

STA/T STEP	PROCEDURE	PANEL	REMARKS
00211	Coarse align err		<p>If P51, 53/P52, 54 in progress, record gyro torquing angles and perform fine align check in P52, 54. Otherwise, refer to V41 N20. Refer to G&N malfunction procedures, symptom 12. Following coarse align, an ICDU is found not to be within 2° of its desired value.</p>
00212	PIPA fail, but PIPA not being used		<p>PIPA BIAS check. Refer to G&N malfunction procedures, symptom 6, step 7. A PIPA fail signal has been received by CMC but PIPAs are not being used (average G not on); or CMC has just finished with PIPAs and finds a PIPA fail signal. For latter case, ISS warning light is extinguished.</p>
00213	IMU not operating with turn-on req		<p>Refer to 00210. CMC has detected an ISS turn-on request but finds ISS operate not present.</p>
00214	Prog using IMU when turned off		<p>Refer to 00210 or exit program. IMU not in use (IMUSE flag reset). IMU in use (IMUSE flag set).</p>
00217	IMU coarse align or pulse torque difficulty has occurred		<p>If 00211 concurrent with 00217, proceed per 00211 recovery. If not, reinitiate current program. If alarm recurs, terminate use of ISS. Refer to G&N malfunction procedures, symptom 12. This alarm is issued in alignment program, P5X, if coarse align or gyro torquing attempted during IMU turn-on, while a cage command is present or while IMU zeroing is taking place. It is also issued if coarse align failure has occurred (code 211) or if CMC detects ISS warning light on at end of a "successful" coarse alignment or gyro torquing process.</p>

ALARM CODES (VO5 N09)

APOLLO-SOYUZ TEST PROJECT (ASTP)
OPERATIONS HANDBOOK

STA/T STEP	PROCEDURE	PANEL	REMARKS
00220	IMU orient unknown		R02. Align or if aligned, set REFSMFLG.
00401	Desired middle gmb1 angle excessive		If MGA >75°, CMC establishes attitude hold. Call W22 - maneuver, or realign IMU. Alarm will be generated if MGA >60° is calculated during: a. Realignment in P52/54 b. Entry attitude in P62 and P64 (if velocity is <27K FPS at .05 G point). c. P20 (options 4 or 5).
00402	Honor second MINKEY torque request		P52 - During MINKEY plane change, if first gyro torquing done, second torquing must be done.
00404	Trgt out of view (90 deg test)		P52. A trunnion angle >90° required to acquire star. This is a priority alarm and will be displayed by CMC with a flashing V05 N09.
00405	Acpt star pair not avail		In P52 and P54, CMC searches for pair of nav stars which are not <30° and not >76° apart. In addition, neither star may be occulted by earth, sun or moon, and each star must be within 38° of optics shaft axis. If no such pair can be found, alarm is displayed automatically by computer with a flashing V05 N09.
00406	Rndz nav not oper		V54 has been entered but rendezvous tracking is not operating. CMC ignores request for marks and reinstates interrupted display, if any. Select P20 (option 0 or 4), or continue.

6.7

ALARM CODES (V05 N09)

NORMAL/BACKUP

APOLLO-SOYUZ TEST PROJECT (ASTP)
OPERATIONS HANDBOOK

STA/T STEP	PROCEDURE	PANEL	REMARKS
20421	W-matrix overflow		Notify STDN but continue. W-matrix automatically reinitialized at next mark.
20430	Orb integration		Notify STDN. Probable state vector uplink required. This may happen if CMC attempts to integrate a state vector that intersects earth. A state vector update may be required.
00500	Not enough jets for some pitch or yaw rotation		Docked DAP.
00501	Not enough jets for some roll rotation		Docked DAP.
00600	Failure in phase match iterations		
00601	Failure in either NC2 or NCC height mnvr iterations		
00602	Failure in outer (phase) loop iterations		
00603	Failure in QRDTPPI iterations		
20607	No solution from time θ or time radius		Reselect program. Vehicle will be in a hyperbolic orbit, or entry angle too steep.
00611	No TIG for given ELEV angle		P34, P35.
00777	ISS warning caused by PIPA fail		Refer to G&N malfunction procedures, symptom 6.
01102	CMC self test err		Self check.
31104	Delay routine busy		Reselect extended verb or continue with program. Notify STDN. An internal routine (DELAYJOB) used by CMC to cause variable time delays, has received requests from more than 4 jobs.
01105	Downlink too fast		Rset. If alarm recurs, DOWNLINK FAILURE. Refer to G&N malfunction procedures, symptom 12.
01106	Uplink too fast		Rset. If alarm recurs, UPLINK FAILURE. Refer to G&N malfunction procedures, symptom 12.

ALARM CODES (VO5 N09)

APOLLO-SOYUZ TEST PROJECT (ASTP)
OPERATIONS HANDBOOK

STA/T STEP	PROCEDURE	PANEL	REMARKS
31107	Phase table failure - assume erasable memory is destroyed		<p>Perform: 1. V74 CMC DOWNLINK 2. P27 as necessary 3. V48 or V44 as necessary (V46/V45) 4. Re-establish REFSMMAT via P51 as necessary.</p> <p>If FRESH START recurs, CMC FAILURE. Refer to malfunction procedures, symptom SSR-3. During CMC restart, a phase table disagreement was found. CMC will perform an automatic fresh start if this condition exists.</p>
31201	Exec overflow - no VAC area		Reselect extended verb and/or continue program.
31202	Exec overflow - no core sets		Refer to 31201.
31203	Waitlist overflow - too many tasks		Refer to 31201.
21204	Neg or zero waitlist call		<p>If average G on or display type extended verb active, continue. Otherwise reselect program.</p>
21206	Second job attempts to go to sleep via keyboard and disp prog		Refer to 21204.
21210	Second attempt is made to stall		<p>Reselect program. Do not attempt use of device while CMC is using it. While performing certain IMU mode switching functions CMC begins a function and then "stalls" until appropriate job has been completed. If a second attempt is made to stall for the same reason (i.e., IMU mode switch), this alarm is generated.</p>

6.7

ALARM CODES (V05 N09)

NORMAL/BACKUP

APOLLO-SOYUZ TEST PROJECT (ASTP)
OPERATIONS HANDBOOK

STA/T STEP	PROCEDURE	PANEL	REMARKS
31211	Illegal interrupt of extended verb		Reset extended verb after optics marking completed. If an internal request for marks (SXTMARK) made, CMC tests to see if mark system already busy or if an extended verb active. If either condition is discovered, alarm is generated.
01301	Arcsin or arccos input >1		Notify STDN, continue.
21302	SQRT called with neg argument		Refer to 21204.
01407	VG incr		P40. Refer to G&N malfunction procedures, symptom 12. CMC has determined that last measured value of ΔV was in such a direction as to cause VG to increase rather than decrease. As long as this condition exists, value of time to go to cutoff is not recalculated (although R1 of N40 will continue to count down) and an automatic engine-off command will <u>not</u> be sent by CMC.
01426	IMU unsatisfactory		Realign or use SCS. Neither +Y stable member axis nor -Y stable member axis within 30° of $V \times R$ where V and R are present vehicle velocity and position vectors respectively. The test for this condition performed at beginning of P61 and P62.
01427	IMU reversed		Note FDAI operation is inverted. The -Y stable member axis is within 30° of $V \times R$ (cf. code 1426).
21501	Keyboard and disp alarm during internal use (NVSUB).		Refer to 21204.
21502	Illegal flashing disp		Refer to 21204.

ALARM CODES (VO5 M09)

APOLLO-SOYUZ TEST PROJECT (ASTP)
OPERATIONS HANDBOOK

STA/T STEP	PROCEDURE	PANEL	REMARKS
01520	V37 req not permitted at this time		Wait until COMP ACTY light not on continuously, reselect V37 or if P62/P67, select P00 and then desired program. Alarm will be generated if a V37 request made with IMU as follows: a. In its 90-second turn-on period b. Being caged c. Being zeroed. It will also be generated if V37 request is made for a program other than P00 after entry DAP has been started in P62, during P77, P00 integration (including P20 options 1, 2, 5 periodic integration), and P06.
21521	P01 illegally sel		Refer to 21204.
01600	Overflow in drift test		This is ground test alarm only.
01601	Bad IMU torque abort		Refer to 01600. Generated in P01, P02, or P07.
01703	Insufficient time for integration		P40, P41. Will occur between TIG -42.5 and TIG -35 seconds.
32000	DAP JASK still in process when next JASK attempted		Docked DAP.
03777	ISS warning caused by ICDU fail		Refer to G&N malfunction procedures, symptom 6.
04777	ISS warning caused by ICDU and PIPA fail		Refer to G&N malfunction procedures, symptom 6.
07777	ISS warning caused by IMU fail		Refer to G&N malfunction procedures, symptom 6.
10777	ISS warning caused by IMU and PIPA fail		Refer to G&N malfunction procedures, symptom 6.
13777	ISS warning caused by IMU and ICDU fail		Refer to G&N malfunction procedures, symptom 6.
14777	ISS warning caused by IMU, ICDU, and PIPA fail		Refer to G&N malfunction procedures, symptom 6.

6.7

ALARM CODES (V05 N09)

NORMAL BACKUP

APOLLO-SOYUZ TEST PROJECT (ASTP)
OPERATIONS HANDBOOK

STA/T STEP	PROCEDURE	PANEL	REMARKS
6.8	CMC PROGRAM - ROUTINE INDEX		
6.8.1	<u>Programs</u>		
	<u>Phase</u>	<u>Program Title</u>	<u>Contains Crew Interface Routines</u>
Pre-Launch & Service	00 CMC idling	R00	
	01 Prelaunch or service init	None	
	02 Prelaunch or service gyro compassing	None	
	03 Prelaunch or service opt verif of gyro compassing	None	
	06 CMC pwr down	R00	
	07 System test		
Boost	11 Earth orb insertion monitor	R00	
Coast	20 Universal track & rnz nav	R00, R02, R07, R21, R22, R23, R27, R52, R60, R61, R67	
	21 Grd track determ	R00	
	25 Contingency R dot	R00, R27	
	27 CMC update	None	
	29 Time of Longitude	R00	

Do not select the following program sequences:
a. P40/P41 - P27 - P52
(P27 overwrites preferred attitude computations) Redo P40/P41 up to V50 N18, then reselect P52
b. P27 - P40/P41 - P52
Reload preferred REFSPMAT from ground.

PROGRAMS

APOLLO-SOYUZ TEST PROJECT (ASTP)
OPERATIONS HANDBOOK

STA/T STEP	PROCEDURE	PANEL	REMARKS
	<u>Program Title</u>	<u>Contains Crew Interface Routines</u>	
	<u>Phase</u>		
	<u>Program No.</u>		
Pre-Thrusting	30 External AV	R00	
	31 A01 targeting	R00,R07	
	32 A02 targeting	R00,R07	
	33 A03 targeting	R00,R07	
	34 A04 targeting	R00,R07	
	35 A05 targeting	R00,R07	
	36 A06 targeting	R00,R07	
	37 A07 targeting	R00,R07	
	38 A08 targeting	R00,R07	
Thrusting	40 BPS	R02,R07,R40, R41,R60,R00	
	41 ECS	R02,R07,R41, R60,R00	R00 via R31.
	42 Thrust mon	R02,R41,R00	
	43 RNDZ thrust mon (final phase)	R02,R07,R27, R41,R00	Called as final program in primary rendezvous sequence.
Align-ment	50 Soyuz orient determ	R00,R02,R53	
	51 IMU orient determ	R02,R53,R54, R00	
	52 IMU realign	R02,R07,R50, R00,R52, R53,R54 R55	
	53 Back-up IMU orient determ	R56,R54,R00	

PROGRAMS

6.8.1

NORMAL BACKUP

APOLLO-SOYUZ TEST PROJECT (ASTP)
OPERATIONS HANDBOOK

STA/T STEP	PROCEDURE	PANEL	REMARKS
		Contains Crew Interface Routines	
<u>Phase</u>	<u>Program No.</u>	<u>Program Title</u>	
	54	Back-up IMU realign	R02,R50,R00, R56,R54,R55
	55	Soyuz Star Tracker Gimbal Angle Program	R02,R53,R00
entry	61	Entry prep	R02
	62	CM/SM sep and pre- entry mnvr	R02
	63	Entry init	None
	64	Post 0.05 3	None
	65	Entry upcontrol	None
	66	Ballistic entry	None
	67	End phase	R00
Post thrusting	77	CSM velocity vector update	R00

Although P65 and P66 are included in the ASTP, they are bypassed in Earth orbit missions and, therefore, are not included in the Entry procedures, see 2-1-1. (For Earth orbit missions, P64 automatically calls P67 as next program.)

PROGRAMS

APOLLO-SOYUZ TEST PROJECT (ASTP)
OPERATIONS HANDBOOK

STA/T STEP	PROCEDURE	PANEL	REMARKS
6.8.2	<u>Routines</u>		
	<u>Routine</u>	<u>Routine Title</u>	
00	Enl auto req term		
01	Erasable & chan modification		
02	EW stat check		
03	Undocked DAP (UDAP) data load		Manually selected by crew (V48E).
04	Docked DAP (DDAP) data load		Manually selected by crew (V44E).
05	MINKEY controller		Initiated by selection of a rndz targeting program.
06	VHF radar read		Selected by R22 when enabled by V77E (disabled by V88E).
07			Selected by R22 via R27 when enabled by V76E (disabled by V77E).
08			Selected by P25 and P48 via R27.
21	Endz tracking sighting mrk		P20 (options 0, 4). Selected by MARM or MAPK EDC.
22	Endz tracking data processing		P20 (options 0, 4).
23	Backup rndz tracking sighting mrk		Manually selected by crew (V54E).
27	VHF range/range rate filter		Selected auto by either P25 or P48. Selected by R22 via V76E (disabled by V77E or by P20 initialization).
30	Crp param disp		May be called by crew (V82E).
31	Rndz param disp routine No. 1		Displays range, range rate, and the angle between CSM +X axis and local horizontal (theta). Selected by crew (V83E), or automatically by MINKEY controller via P37.

ROUTINES

6.8.2

NORMAL BACKUP

APOLLO-SOYUZ TEST PROJECT (ASTP)
OPERATIONS HANDBOOK

STA/T STEP	PROCEDURE	PANEL	REMARKS
	<u>Routine Title</u>		
34	Rndz param disp routine No. 2		Displays range, range rate, and angle between optics star line of sight and local horizontal (ϕ). Selected by crew (V85E).
36	Rndz out of plane disp		Selected by V90E.
40	SPS thrust fail		Selected by P40.
41	State vctr integration (mid to ave)		Selected by P40, P41, P47, P48.
50	Coarse align		Selected by P52, P54.
52	Auto opt positioning		Automatically selected by P20 or P52. It is self-perpetuating and terminated by R53 for star sightings.
53	Sighting mrk		Selected in R52 by OPT MODE - MAN or OPT ZERO - ZERO. Selected in P50, N06 (options 1 or 2).
54	Sighting data disp		Selected auto in P51, P52.
55	Gyro torquing		Selected in P55, N06 (option 2).
56	Alternate LOS sighting mrk		Selected auto by P51, P52, P53, P54.
60	Att mnvr		Selected auto by P52, P54.
61	Tracking att		Used to perform sighting marks for backup alignment programs P53 and P54.
62	Crew defined mnvr		Selected by P40, P41, R61(P20), R62(V49E), R63(V89E).
63	Rndz fnl att		Orients CSM properly with respect to target vehicle during target tracking. Selected auto by P20 and by R52 during P20.
64	Opt angle transform		Selected by (V49E) via P00 only.
67	Rotation mnvr		Selected by (V89E) via P00 only. Selected by (V64E). P20 (option 2).

ROUTINES

ADOLLO-SOYUZ TEST PROJECT (ASTP)
OPERATIONS HANDBOOK

6.9 CMC PROGRAM - FLAG LISTING (Defines Location & Utilization)

<u>Title</u>	<u>Code</u>	<u>Flag Word</u>	<u>Memory Address</u>	<u>Bit</u>	<u>When Set</u>	<u>When Reset</u>
	P29FLAG	0	00074	1	P29 running. 1st pass in progress	P29 finished with 1st pass
Rendezvous	NC12FLG	0	00074	5	P32 (NC2)	P31 (NC1)
Sighting mark	SCFMK	0	00074	6	FL V51 initiated	FL V51 not initiated
Rendezvous	RNDVZFLG	0	00074	7	P20 (option 0 or 4) initiated	P20 (option 1, 2, 5) initiated
IMU	IMUSE	0	00074	8	IMU in use	IMU not in use
Alignment	P50FLAG	0	00074	10	P50 initiated	P50 not initiated
	P50.1FLG	0	00074	12	P50 option 1 selected	P50 option 1 not selected
	P55.1FLG	0	00074	13	P55 option 1 selected	P55 option 1 not selected
Marking	MARKFLG	1	00075	4	Mark accepted, allow mark reject	Mark not accepted, do not mark reject
Track	TRACKFLG	1	00075	5	P20 tracking	P20 not tracking
Update	UPDATFLG	1	00075	7	State vector updating by marks allowed	State vector updating by marks not allowed

6.9

CMC PROGRAM - FLAG LISTING

NORMAL BACKUP

APOLLO-SOYUZ TEST PROJECT (ASTP)
OPERATIONS HANDBOOK

<u>Title</u>	<u>Code</u>	<u>Flag Word</u>	<u>Memory Address</u>	<u>Bit</u>	<u>When Set</u>	<u>When Reset</u>
State vectr	CSUPDAT	1	00075	8	CSM state vector to be updated by nav measurement. Can be set by V8LE.	Soyuz state vector to be updated by nav measurement. Can be reset by V80E.
Tgt 1	SMSTRG	1	00075	10	Sighting Soyuz	Not sighting Soyuz.
Prelaunch	WODOPO1	1	00075	12	Inhibits P01 (set 1 near start of P11)	Enables P01 (set C by pad load)
Stick flag	STKFLAG	1	00075	14	RHC out of detent or MGA >75° (auto maneuver not enabled)	RHC in detent & MGA <75° (auto maneuver enabled)
Preferred att	PRRATTG	2	00076	4	Preferred SC attitude computed	Preferred SC attitude not computed
Final computation	FINALFLG	2	00076	6	Final pass through rendezvous program computations	Interim pass through rendezvous program computations
External AV	XDVELFLG	2	00076	7	External AV VG computations	Lambert VG computations
	ITERFLG	2	00076	13	15 iterations have occurred	15 iterations have not occurred
Marking (P20)	SMARK	2	00076	14	P20 (options 0 or 4) active (special mark processing & optics rather than B/U marks being processed). Set on V54 (R23) exit.	P20 (options 1, 2, 5) active

APOLLO-BOYUZ TEST PROJECT (ASTP)
OPERATIONS HANDBOOK

<u>Title</u>	<u>Code</u>	<u>Flag Word</u>	<u>Memory Address</u>	<u>Bit</u>	<u>When Set</u>	<u>When Reset</u>
Gyro drift compensation	DRIFTFLG	2	00076	15	Drifting flight gyro compensation performed	Drifting flight gyro compensation not performed
Locked/Undocked DAPS	L5/L4FLG	3	00077	6	V45E	V46E
LPO Orientation known (REFSMAT)	REFSMFLG	3	00077	13	REFSMAT good	REFSMAT not good
Gimbal lock	GLOCKFAIL	3	00077	14	Gimbal lock has occurred	Not in gimbal lock
Auto maneuvers	V50M187L	3	00077	15	Start of P20, V37E, or V58E (unless P00 selected). If A angle >10° in R61, R60 entered	Upon completion of R61
(See DR listing)		4	00100			
W matrix (rndz nav)	RENDWFLG	5	00101	1	W matrix for rendezvous navigation is valid	W matrix for rendezvous navigation is invalid
Liftoff discrete	EXUPL0	5	00101	5	V75E backup of L/O discrete	Prior to L/O. Remains reset if no V75E
3 axis	3AXISFLG	5	00101	6	Maneuver specified by 3-axes: P20 (option 4, 5), V49	Maneuver specified by VECPOINT P20 (option 0, 1), P40/P41, V89
Rendezvous	ITSWICH	7	00103	14	Solution for TPI time not reached	Solution for TPI time reached
Terminate	TERMIFLG	7	00103	15	Terminate R52 and R53	Do not terminate

APOLLO-SOYUZ TEST PROJECT (ASTP)
OPERATIONS HANDBOOK

<u>Title</u>	<u>Code</u>	<u>Flag Word</u>	<u>Memory Address</u>	<u>Bit</u>	<u>When Set</u>	<u>When Reset</u>
Tracking (P20)	R67FLAG	8	00104	2	R67 (P20 option 2) rotation active	R67 rotation not active
P00 integration	V96ONFLG	8	00104	3	P00 integration inhibited. Set by V96E	Integration proceeding normally (P00 selected)
Tracking (P20)	UTFLAG	8	00104	9	P20 (options 1, 2, 5) selected	P20 (options 0, 4) selected, or by P00, V56E, P06, P00D00 or IMU turn off
Select R31/R34	R31FLAG	9	00105	4	V83E (request R31)	V85E (request R34)
Terminate periodic P00 integration	QUITFLAG	9	00105	5	V96E (stop P00 periodic state vector integration)	Reset in P00 (if found to be set) remains reset until new prog (other than P27) selected.
FDAI error (N22 or N17)	N22ERNDS	9	00105	6	V62E	V63E
Marking (R22)	R22CAFLG	9	00105	7	Optics mark being processed	Optics mark not being processed
Marking (R22)	VHFSOURC	9	00105	8	VHF radar used as input source for marks	Optics mark used as input source
VHF ranging	VHFRFLAG	9	00105	9	V87E Process VHF ranging data (periodically)	V88E (or R00) do not process VHF ranging data

CMC PROGRAM - FLAG LISTING

APOLLO-SOYUZ TEST PROJECT (ASTP)
OPERATIONS HANDBOOK

<u>Title</u>	<u>Code</u>	<u>Flag Word</u>	<u>Memory Address</u>	<u>Bit</u>	<u>When Set</u>	<u>When Reset</u>
Targeting (P38)	POFLAG	10	00106	1	In P38 (P38 plane change trgtng to be done)	Not P38, PRO on V50 M25 (RI = 17), in P52 if puis. torquing done.
Warnings	TJUNKFLG	10	00106	2	Either optics or VLF marks to be taken (set in V57)	Both optics and VLF marks to be taken (reset in V57)
Targeting (P35)	CPINFLG	10	00106	3	TPI targeting complete	TPI targeting not complete
	EV93FLG	10	00106	4	V93 to be done after maneuver	Maneuver and V93 done
	MANEUFLG	10	00106	5	Indicates no mark has been processed since last final computation cycle of a targeting program (except P38). Set on PRO response to FL V50 M25 (RI = 00017)	Mark incorporated in P12
Plane change	TCOMPFLG	10	00106	6	(- then + torque)	(+ then - torque)
MINKEY rendezvous	AUTOSEQ	10	00106	7	Automatic rendezvous (MINKEY) sequence running	Non-MINKEY rendezvous selected
Rendezvous	P35FLAG	10	00106	8	MCC targeting done	MCC targeting not done

CMC PROGRAM - FLAG LISTING

6.9

NORMAL BACKUP

APOLLO-SOYUZ TEST PROJECT (ASTP)
OPERATIONS HANDBOOK

<u>Title</u>	<u>Code</u>	<u>Flag Word</u>	<u>Memory Address</u>	<u>Bit</u>	<u>When Set</u>	<u>When Reset</u>
Ranging (P20)	EXTRANGE	10	00106	9	In R61	In R00
Tracking	HDSUPFLG	10	00106	11	Heads-up attitude	Heads-down attitude
Marking	REJCTFLG	10	00106	12	Mark to be rejected in R22 by MARK REJ or V86	No mark reject in R22 (reset in R22 after mark processing)
Maneuver (P20)	PCMANFLG	10	00106	15	P20 NPC maneuver	No P20 NPC maneuver
Rendezvous	R27UP1	11	00107	1	1st pass in R27 complete	1st pass not complete
Rendezvous	R27UP2	11	00107	2	2nd pass in R27 complete	2nd pass not complete
Rendezvous	TDFLAG	11	00107	3	TD angle in R27 computed	TD angle in R27 not computed
Ranging	P25FLAG	11	00107	4	P25 operating	P25 not operating
Thrusting	P48FLAG	11	00107	5	P48 operating	P48 not operating
Rendezvous	SNAPFLAG	11	00107	6	Inhibit R22 mrk processing	Allow R22 mrk processing
Rendezvous	FIXFLAG	11	00107	7	R27 in optimizing mode	R27 in current mode
Tracking (P20)	AZIMFLAG	11	00107	8	P20 (options 4, 5). Indicates 3-axis maneuver desired in R61	P20 (options 0, 1, 2) and by V89 before maneuver calculated

CMC PROGRAM - FLAG LISTING

APOLLO-SOYUZ TEST PROJECT (ASTP)
OPERATIONS HANDBOOK

<u>Title</u>	<u>Code</u>	<u>Flag Word</u>	<u>Memory Address</u>	<u>Bit</u>	<u>When Set</u>	<u>When Reset</u>
Ranging	N77FLAG	11	00107	9	N77 = optimized R dot	Allow current state in N77
Display	NOUNFLG	11	00107	10	Display N77	Display N76
Rendezvous	CYCLFLAG	11	00107	11	R27 processing mark	R27 ready for new mark
Rendezvous	R27FLAG	11	00107	12	Allow R27 in P20 (V76E)	Inhibit R27 in P20 (V77E)
ISS zero	IMODES30		01323	9	IMU operate bit present (set to 0)	IMU operate bit not present (reset to 1)
Att hold	HOLDFLAG		01330		(+) Sample CDU angles before resuming attitude hold and resetting HOLDFLAG to (+0). (+0) Remain in attitude hold at previously established reference angles. Set (this state) by DAP when $ MGA > 75^\circ$ (-) Enable automatic steering.	

NORMAL BACKUP

APOLLO-SOYUZ TEST PROJECT (ASTP)
OPERATIONS HANDBOOK

STA/T STEP	PROCEDURE	PANEL	REMARKS
7.0	G&C REFERENCE MODES		<p>This section provides information about basic G&C functions by defining them in terms of system operating prerequisites and switch positions which together represent reference modes. Their scope is limited to independent system functions. These reference modes are repeatable and are applicable to all G&C procedures and thus are referenced in all subsequent sections of G&C procedures. The modes, however, are NOT intended to be complete or self-contained procedures.</p> <p>Whenever a step in one of these G&C reference modes references another mode, the title and paragraph number of the referenced mode is shown and the recommended options in the mode, if any, are specified. Only those switches which are required to be in unique positions are shown in the affected step after the mode is referenced.</p> <p>During time-critical mission phases, reference to other sections of the handbook cannot be accommodated, and, therefore, all time-critical operations are self-contained. Modes similar to those shown in this section, however, are contained or repeated within the time-critical procedures.</p> <p>For general G&C operating data, refer to operating notes, 6.1.</p>
7.1	ATTITUDE CONTROL		
7.1.1	SCS Channel Selection		<p>Provides methods for enabling RCS auto coils without undesirable jet firings.</p>
1	Set pwr sw	7	<p>Supplies 28 vac to SC CONT switch, THC CW switch and ATT 1/RATE 2 and RATE 2 positions of BMAG MODE switches.</p>
AC	LOGIC 2/3 PWR - on (up)		6.1.2, note 5.
	SIG COMDR/DR BIAS PWR (both) - AC1 or AC2		

7.1.1

SCS CHANNEL SELECTION

NORMAL BACKUP

APOLLO-SOYUZ TEST PROJECT (ASTP)
OPERATIONS HANDBOOK

STA/T STEP	PROCEDURE	PANEL	REMARKS
2	Enable auto coils For CMC cont SC cont - CMC/FREE SC CONT - CMC CMC MODE - FREE MAN ATT (3) - MIN IMP or RATE CMD AUTO RCS (16) - as desired	1	For post CM/SM separation, AUTO RCS A/C ROLL switches should be OFF, and DAP configured for S/D roll. Also refer to 6.1.1, note 8. 6.1.1, note 9.
AC	For SCS cont a. SC cont - SCS SC CONT - SCS or SC CONT - CMC THC - CW b. EMAG MODE (3) - RATE 2 or MAN ATT (3) - MIN IMP or ACCEL CMD c. AUTO RCS (16) - MNA or MNB	8	EMAG MODE or MAN ATT switching prevents attitude error signals from causing jet firings. For SCS control, switches should be set by quad and rotation axis, as desired. Only one roll quad should be enabled for SCS control to optimize RCS fuel consumption. One exception is 3-axis translation when all quads required.

SCS CHANNEL SELECTION

APOLLO-SOYUZ TEST PROJECT (ASTP)
OPERATIONS HANDBOOK

STA/T STEP	PROCEDURE	PANEL	REMARKS
AC	<p>7.1.2 <u>SCS Minimum Impulse</u></p> <p>1 Set pwr sw ELEC PWR - CDC/ECA or ECA</p> <p>LOGIC 2/3 PWR - on (up) SIG CONDR/DR BIAS PWR (both) - AC1 or AC2 RHC PWR NORM (both) - AC/DC</p>	7	<p>Either position required for minimum impulse generator.</p> <p>Supplies 28 vdc to SC CONT and THC CW switches. 6.1.2, note 5.</p>
	<p>2 Sel min imp cont SC cont - SCS/MIN IMP SC CONT - SCS MAN ATT - MIN IMP</p> <p>or SC CONT - CMC MAN ATT - MIN IMP THC - CW</p>	1	<p>Switches should be set by axis as desired.</p>
	<p>3 Enable auto coils, 7.1.1</p>		
	<p>7.1.3 <u>SCS Acceleration Command</u></p>		
	<p>1 Set pwr sw LOGIC 2/3 PWR - on (up) SIG CONDR/DR BIAS PWR (both) - AC1 or AC2 RHC PWR NORM (both) - AC/DC</p>	7	<p>Supplies 28 vdc to SC CONT switch. 6.1.2, note 5.</p>
	<p>2 Sel accel cmd cont MAN ATT - ACCEL CMD</p>	1	<p>Switches should be set by axis as desired.</p> <p>Either CMC or SCS control permissible while enabling coils.</p>
	<p>3 Enable auto coils, 7.1.1</p>		

SCS ACCELERATION COMMAND

7.1.3

NORMAL BACKUP

APOLLO-SOYUZ TEST PROJECT (ASTP)
OPERATIONS HANDBOOK

STA/T STEP	PROCEDURE	PANEL	REMARKS
AC	<p>7.1.1.4 SCS Attitude Hold/Rate Command</p> <p>1 Set pwr sw LOGIC 2/3 PWR - on (up) ELEC PWR - GDC/ECA or ECA SIG CONDR/DR BIAS PWR 1 - AC1 or AC2</p> <p>BMAG PWR (both) - ON</p> <p>RHC PWR NORM (1, 2 or BOTH) - AC/DC</p>	7	<p>Supplies 28 vdc to SC CONT switch.</p> <p>Provides SCS signal conditioner power for RHC proportional rate command TEM. Also refer to 6.1.1.2, note 5.</p> <p>If rate damping only desired, BMAG 1 need not be turned ON but should be set to WARPUP.</p> <p>If manual override of attitude hold desired.</p>
2	<p>Enable auto coils, 7.1.1.1</p>	1	<p>6.1.1.1, note 8.</p>
3	<p>Establish att hold/rate cmd SC cont - SCS/RATE CMD SC CONT - SCS MAN ATT - RATE CMD</p> <p>or SC CONT - CMC MAN ATT - RATE CMD THC - CW</p> <p>SC cont - SCS/att hold SC CONT - SCS MAN ATT - RATE CMD</p>		<p>Switches may be set by axis as desired. Also refer to 6.1.1.2, note 6.</p> <p>MAN ATT - RATE CMD and BMAG MODE - ATT 1/RATE 2 inclusive required to establish attitude hold.</p>

SCS ATTITUDE HOLD/RATE COMMAND

APOLLO-SOYUZ TEST PROJECT (ASTP)
OPERATIONS HANDBOOK

STA/T STEP	PROCEDURE	PANEL	REMARKS
AC	or SC CONT - CMC MAN ATT - RATE CMD THC - CW EMAG MODE - ATT 1/RATE 2 7.1.5 <u>CMC Minimum Impulse</u> 1 The following are req CMC - on, 8.1.3 RCS DAP - load & activate, 8.2.1 ISS - on (desired), 8.1.3 2 Set pwr sw LOGIC 2/3 PWR - on (up) SIG CONDR/DR BIAS PWR (both) - AC1 or AC2 RHC FWR NORM (both) - AC/DC 3 Establish CMC Cont SC cont - CMC/MIN IMP SC CONT - CMC CMC MODE - FRFE MAN ATT (3) : : IMP	1	<p>CMC, ISS, and RCS DAP enable autopilot control. Minimum impulse controller (MIC), located on panel 122 in LEB, and RHC provide minimum impulse command capability in this mode. RHC will provide normal acceleration commands providing MAY ATT switches at ACCEL CMD.</p> <p>For display of ISS total attitude and errors.</p> <p>Supplies 28 vdc to SC CONT switch. 6.1.2, note 5.</p> <p>ACCEL CMD position cannot be used (inhibits CMC outputs to jets).</p>

CMC MINIMUM IMPULSE

7.1.5

NORMAL BACKUP

APOLLO-SOYUZ TEST PROJECT (ASTP)
OPERATIONS HANDBOOK

STA/T STEP	PROCEDURE	PANEL	REMARKS
AC	or SC CONT - CMC CMC MODE - FREE MAN ATT (3) - RATE CMD EMAG MODE (3) - RATE 2 For accel cmds MAN ATT (3) - ACCEL CMD 4 Enable Auto Coils, 7.1.1 7.1.6 <u>CMC Attitude Control - Auto/Hold</u> 1 The following are req CMC - on, 8.1.3 ISS - on, 8.1.3 RCS DAP - load & activate, 8.2.1	1	6.1.1, note 9. CMC, ISS, and RCS DAP enable autopilot control.
2	Set pwr sw LOGIC 2/3 PWR - on (up) SIG CONDR/DR BIAS PWR (both) - AC1 or AC2	7	Supplies 28 vdc to SC CONT switch. 6.1.2, note 5.
3	Enable auto coils, 7.1.1	1	AUTO position must be selected when CMC automatic maneuver desired.
4	Establish att cont SC cont - CMC/AUTO SC CONT - CMC CMC MODE - AUTO MAN ATT - MIN IMP	1	

CMC ATTITUDE CONTROL - AUTO/HOLD

APOLLO-SOYUZ TEST PROJECT (ASTP)
OPERATIONS HANDBOOK

STA/T STEP	PROCEDURE	PANEL	REMARKS
AC	<p>or SC CONT - CMC CMC MODE - AUTO MAN ATT - RATE CMD</p> <p>SC cont - CMC/HOLD SC CONT - CMC CMC MODE - HOLD MAN ATT - MIN IMP</p> <p>or SC CONT - CMC CMC MODE - HOLD MAN ATT - RATE CMD</p> <p><u>7.1.7 SIVB Attitude Control</u></p>	1	Describes condition required to enable RHC rate control of SIVB.
	<p>1 The following are req CMC - on, 8.1.3 LOGIC 2/3 PWR - on (up)</p> <p>ISS - on (desired), 8.1.3</p>	7	Supplies power for caging BMAGs via BMAG MODE switches. For display of ISS total attitude and errors.
CP	<p>2 Enable att cont Saturn DAP activated, 8.2.1</p> <p>LV GUID sv - CMC</p>	2,140	Load 3 in configuration option of DAP activation procedure. Also refer to 6.1.1, note 8. When RCS CMD - ON, AUTO RCS switches should be off to prevent SM jet firing.
		2	SIVB attitude control for boost normally provided by IU. Switch is set to CMC if SIVB takeover required.

SIVB ATTITUDE CONTROL

7.1.7

NORMAL BACKUP

APOLLO-SOYUZ TEST PROJECT (ASTP)
OPERATIONS HANDBOOK

STA/T STEP	PROCEDURE	PANEL	REMARKS
7.1.8	<u>Direct RCS</u>		Provides RCS direct coil commands when PHC deflected (=11°) to direct switches. Direct commands inhibit SCS and CMC commands to auto coils in respective axis (or axes). RCS continues to fire as long as direct commands present. G&N and/or SCS systems may be on or off.
AC	SIG CONDR/DR BIAS PWR 1 - AC1 or AC2	7	Provides SCS signal conditioner power for RHC direct enable TLM. Also refer to 6.1.2, note 5.
1	Enable direct RCS <u>Full authority</u> RHC PWR DIR (1, 2 or both) - MNA/MNE		All RCS direct coils enabled.
or	RHC PWR DIR 1 - MNA RHC PWR DIR 2 - MNB		
	Maneuver RHC - deflect to hardstops		If G&N/SCS systems on, and configured to fire RCS jets, will have momentary firing of auto coils until direct switches close (in axis). Closing direct switches inhibits both + and - auto commands.
	<u>Half authority</u>		Configures direct RCS for half authority, which prevents more than two SM RCS roll thrusters and more than one pitch and yaw thruster from firing in any one direction. If consideration essential, also provides method of minimizing RCS propellant consumption in direct RCS mode.

DIRECT RCS

APOLLO-SOYUZ TEST PROJECT (ASTP)
OPERATIONS HANDBOOK

STA/T STEP	PROCEDURE	PANEL	REMARKS																																	
AC	<p>cb SCS CONTR DIR 1 MNB (MNA) - open cb SCS CONTR DIR 2 MNB (MNB) - open RHC PWR DIR (both) - MNA/MNB</p> <p>Maneuver RHC - deflect to hardstops</p> <p>2 To terminate direct RCS RHC - neutral</p> <p>3 To inhibit direct RCS RHC PWR DIR (1, 2 or both) - OFF</p> <p>7.2 DYNAMIC DISPLAY MONITOR</p> <p>7.2.1 <u>Rate Display</u></p> <p>1 Set pwr sw FDAI/GPI PWR - 1, 2 or BOTH</p>	<p>8 1</p>	<p>Enables following direct thrusters:</p> <table border="1" style="margin-left: 40px;"> <tr> <td colspan="3" style="text-align: center;">cb's open</td> </tr> <tr> <td>DIR 1 MNB</td> <td>DIR 1 MNA</td> <td></td> </tr> <tr> <td>DIR 2 MNB</td> <td>DIR 2 MNA</td> <td></td> </tr> <tr> <td colspan="3" style="text-align: center;">Jets enabled</td> </tr> <tr> <td>AXIS</td> <td>Jets enabled</td> <td>Jets enabled</td> </tr> <tr> <td>+P</td> <td>C3</td> <td>A3</td> </tr> <tr> <td>-P</td> <td>A4</td> <td>C4</td> </tr> <tr> <td>+Y</td> <td>B3</td> <td>D3</td> </tr> <tr> <td>-Y</td> <td>D4</td> <td>B4</td> </tr> <tr> <td>+R</td> <td>C1, A1</td> <td>D1, B1</td> </tr> <tr> <td>-R</td> <td>C2, A2</td> <td>D2, B2</td> </tr> </table> <p>Provides methods for displaying rate information on rate needles of FDAI 1 or FDAI 2, or both, as desired.</p> <p>Provides power for display electronics. Position chosen depends on which FDAI(s) desired.</p>	cb's open			DIR 1 MNB	DIR 1 MNA		DIR 2 MNB	DIR 2 MNA		Jets enabled			AXIS	Jets enabled	Jets enabled	+P	C3	A3	-P	A4	C4	+Y	B3	D3	-Y	D4	B4	+R	C1, A1	D1, B1	-R	C2, A2	D2, B2
cb's open																																				
DIR 1 MNB	DIR 1 MNA																																			
DIR 2 MNB	DIR 2 MNA																																			
Jets enabled																																				
AXIS	Jets enabled	Jets enabled																																		
+P	C3	A3																																		
-P	A4	C4																																		
+Y	B3	D3																																		
-Y	D4	B4																																		
+R	C1, A1	D1, B1																																		
-R	C2, A2	D2, B2																																		

7.2.1

RATE DISPLAY

NORMAL BACKUP

APOLLO-SOYUZ TEST PROJECT (ASTP)
OPERATIONS HANDBOOK

STA/T STEP	PROCEDURE	PANEL	REMARKS
AC	LOGIC 2/3 PWR - on (up) EMAG 2 PWR - ON (req if BMAG 2 desired) EMAG 1 PWR - ON (req if BMAG 1 desired)	7	6.1.1.1, note 7. Either BMAG 1 or BMAG 2 may be selected to provide information. BMAG 2 normally used and BMAG 1 provides backup capability.
2	Sel desired rate source EMAG MODE - RATE 2 or ATT 1/RATE 2	1	Switches should be set by axis as desired. Selects BMAG 2.
or	EMAG MODE - RATE 1		Selects BMAG 1.
3	Sel disp configuration FDAI SEL - 1		Displays rate from BMAG 1 or 2 on FDAI 1 only.
or	FDAI SEL - 2		Displays rate from BMAG 1 or 2 on FDAI 2 only.
or	FDAI SEL - 1/2		Displays rate from BMAG 1 or 2 on both FDAIs.
7.2.2	<u>Attitude Error Display - EMAG Source</u>		Provides methods for displaying EMAG 1 attitude error information on FDAI 1 or FDAI 2. Needles display attitude excursion from point at which BMAGs are uncaged up to a maximum of 17°.
1	Set pwr sw FDAI/GPI PWR - 1, 2 or BOTH	7	Provides power for display electronics. Position chosen depends on which FDAI(s) desired.

ATTITUDE ERROR DISPLAY - EMAG SOURCE

APOLLO-SOYUZ TEST PROJECT (ASTP)
OPERATIONS HANDBOOK

STA/T STEP	PROCEDURE	PANEL	REMARKS
AC	<p>LOGIC 2/3 PWR - on (up)</p> <p>BMAG 1 PWR - ON</p> <p>2 Provide att err info MAN ATT - RATE CMD</p> <p>BMAG MODE - ATT 1/RATE 2 .05 G sw - OFF (verify)</p> <p>RHC - neutral</p> <p>3 Sel disp configuration</p> <p>a. FDAI SEL - 1/2</p> <p>b. FDAI SEL - 1 or 2 FDAI SOURCE - GDC</p> <p>7.2.3 Attitude Error Display - CMC Source</p> <p>1 The following are req CMC - on, 8.1.3 ISS - on, 8.1.3</p>	<p>7</p> <p>1</p>	<p>Supplies power for caging BMAGs via BMAG MODE switches.</p> <p>Powers BMAGs in gyro assembly 1, the only BMAGs capable of providing attitude error information.</p> <p>Switches should be set by axis as desired. RATE CMD position required to uncage BMAG 1. However, RHC breakout and MAN ATT switches overridden by ICM 2 logic signal during thrusting to uncage BMAGs.</p> <p>On (up) position not desirable (cages BMAGs).</p> <p>If RHC breakout switches activated, BMAGs caged (by axis) and attitude hold lost.</p> <p>Displays attitude error from BMAG 1 on FDAI 2.</p> <p>Displays attitude error from BMAG 1 on FDAI 1 or 2. This position required when only one FDAI selected.</p> <p>Provides G&N computed attitude error in control axes. Information meaningful only when computer program defines desired attitude.</p> <p>Required to compute error and mode CDUs. Required for attitude information.</p>

ATTITUDE ERROR DISPLAY - CMC SOURCE

NORMAL BACKUP

7.2.3

APOLLO-SOYUZ TEST PROJECT (ASTP)
OPERATIONS HANDBOOK

STA/T STEP	PROCEDURE	PANEL	REMARKS
1C	<p>2 Set pwr sw FDAI/GPI PWR - 1, 2 or BOTH</p> <p>LOGIC 2/3 PWR - on (up)</p>	7	<p>Provides power for display electronics. Position chosen depends on which FDAI(s) desired.</p> <p>Provides power for FDAI switches.</p>
3	<p>Sel disp scaling FDAI SCALE 5/5 or 5/1</p>	1	<p>Positions provide for compatible scaling between CMC and display electronics in roll axis during orbital flight. If 50/15, 50/10 position chosen, roll scaling 12.5° full scale.</p>
4	<p>Sel disp configuration</p> <p>a. FDAI SEL - 1/2</p> <p>or b. FDAI SEL - 1 or 2 FDAI SOURCE - CMC</p>		<p>Displays attitude error from CDUs on FDAI 1.</p> <p>Displays attitude error from CDUs on FDAI 1 or 2. This position required when only one FDAI selected.</p>
7.2.4	<p><u>Attitude Error Display - Attitude Set Source</u></p>		<p>Provides methods for displaying attitude difference between attitude set indicators and GDC (bock error) or IMU gimbal angles (Euler error). Polarity reversal occurs when ATT SET - IMU option selected and roll gimbal angle >+90°. Pitch and yaw attitude error needles become "fly from" indicators rather than "fly to" indicators in this instance.</p>
1	<p>Set pwr sw & disp logic FDAI/GPI PWR - 1, 2 or BOTH</p>	7	<p>Provides power for display electronics. Position depends on which FDAI desired.</p>

ATTITUDE ERROR DISPLAY - ATTITUDE SET SOURCE

APOLLO-SOYUZ TEST PROJECT (ASTP)
OPERATIONS HANDBOOK

STA/T STEP	PROCEDURE	PANEL	REMARKS
AC	LOGIC 2/3 PWR - on (up) FDAI SEL - 1 or 2 FDAI SOURCE - ATT SET .05 G sw - OFF (verify)	7 1	Display not available at 1/2 position. Required to enable attitude set input to FDAI. On (up) position not desirable (cages BMAGs).
2	Sel att ref		
a.	SCS ELEC PWR - GDC/ECA BMAG 2 PWR - ON ATT SET - GDC BMAG MODE - RATE 2 or ATT 1/RATE 2	7 1	Provides power to GDC electronics. Switches should be set by axis as desired.
b.	ISS ISS - on, 8.1.3 ATT SET - IMU		6.1.1.1, note 6.
7.2.5	<u>Total Attitude</u>		Provides methods for displaying Euler angles on FDAI ball from GDC or IMU.
1	Set pwr sw & enable FDAI FDAI/GPI PWR - 1, 2 or BOTH	7	Provides power for display electronics. Position depends on which FDAI(s) desired.
2	LOGIC 2/3 PWR - on (up)		Supplies power for FDAI, EMAG MODE switches and ATT SET switch (IMU position).
2	Sel disp & disp source a. ISS disp ISS - on, 8.1.3 FDAI 1 disp	1	Enables IMU resolver outputs to FDAI 1 ball drive. There are three possible switch combinations.

7.2.5

TOTAL ATTITUDE

NORMAL BACKUP

APOLLO-SOYUZ TEST PROJECT (ASTP)
OPERATIONS HANDBOOK

STA/T STEP	PROCEDURE	PANEL	REMARKS
AC	FDAI SEL - 1/2 or FDAI - 1/CMC FDAI SEL - 1 FDAI SOURCE - CMC or FDAI - 1/ATT SET/IMU FDAI SEL - 1 FDAI SOURCE - ATT SET ATT SET - IMU FDAI 2 disp FDAI - 2/CMC FDAI SEL - 2 FDAI SOURCE - CMC or FDAI - 2/ATT SET/IMU FDAI SEL - 2 FDAI SOURCE - ATT SET ATT SET - IMU b. GDC disp ELEC PWR - GDC/ECA BMAG 2 PWR - ON BMAG MODE - RATE 2 or ATT 1/RATE 2 XXXXXXXXXXXXXXXXXXXXXXXXXXXXXXXX X BMAG 1 PWR - ON (if BMAG 2 fails) BMAG MODE - RATE 1 X XXXXXXXXXXXXXXXXXXXXXXXXXXXXXXXX X	1	This position also enables GDC total attitude to FDAI 2. 6.1.1.1, note 6. Enables IMU resolver outputs to FDAI 2 ball drive. There are two possible switch combinations. 6.1.1.1, note 6. Provides power to GDC electronics. Switches should be set by axis as desired.

TOTAL ATTITUDE

APOLLO-SOYUZ TEST PROJECT (ASTP)
OPERATIONS HANDBOOK

STA/T STEP	PROCEDURE	PANEL	REMARKS
AC	<p>FDAl 2 disp FDAl SEL - 1/2</p> <p>or</p> <p>FDAl - 2/GDC FDAl SEL - 2 FDAl SOURCE - GDC</p> <p>or</p> <p>FDAl - 2/ATT SET/GDC FDAl SEL - 2 FDAl SOURCE - ATT SET ATT SET - GDC</p> <p>FDAl 1 disp FDAl - 1/GDC FDAl SEL - 1 FDAl SOURCE - GDC</p> <p>or</p> <p>FDAl - 1/ATT SET/GDC FDAl SEL - 1 FDAl SOURCE - ATT SET ATT SET - GDC</p> <p>7.2.6 <u>ORDEAL - Local Horizontal Attitude</u></p>	1	<p>Enables GDC resolver outputs to FDAl 2 ball drive. There are three possible switch combinations.</p> <p>Enables GDC resolver outputs to FDAl 1 ball drive. There are two possible switch combinations.</p>
	<p>1 Set pwr sw FDAl/GPI PWR - 1, 2 or BOTH</p>	7	<p>Provides methods for displaying local horizontal reference established by ORDEAL on FDAl 1 and/or FDAl 2 balls. Only pitch axis affected.</p> <p>Provides power for display electronics. Position chosen depends on which FDAl(s) desired.</p>

ORDEAL - LOCAL HORIZONTAL ATTITUDE

7.2.6

NORMAL BACKUP

APOLLO-SOYUZ TEST PROJECT (ASTP)
OPERATIONS HANDBOOK

STA/T STEP	PROCEDURE	PANEL	REMARKS
AC	EARTH/LUNAR - EARTH LTG - BRT or DIM	13	Reference system may be GDC or IMU, 7.2.5.
2	Sel disp configuration FDAl 1 disp FDAl - 1/ORB RATE FDAl SEL - 1 or 1/2 FDAl 1 sw - ORE RATE	1 13	
	FDAl 2 disp FDAl - 2/ORB RATE FDAl SEL - 2 or 1/2 FDAl 2 sw - ORB RATE	1 13	
	FDAl 1 & 2 disp FDAl - both/ORB RATE FDAl SEL - 1/2 FDAl sw (both) - ORB RATE	1 13	Aligns GDC to ATT SET thumbwheels. Supplies power to GDC electronics. Enables attitude set inputs to GDC.
7.3	GDC ALIGN ELEC PWR - GDC/ECA ATT SET - GDC Verify tw settings GDC ALIGN: pb - push	7 1	Enables attitude set inputs to GDC and disables BMAG inputs.

ORDEAL - LOCAL HORIZONTAL ATTITUDE

APOLLO-SOYUZ TEST PROJECT (ASTP)
OPERATIONS HANDBOOK

STA/T STEP	PROCEDURE	PANEL	REMARKS
7.4	SPS THRUSTING CONTROL		Defines safe switch configuration required before initiation of thrusting procedures.
7.4.1	<u>TVC Initialization</u>		Provides power to SCS TVC switches. Required for RCS jet on-off and MTVC TLY. Lever lock.
AC	LOGIC 2/3 PWR - on (up) SIG CONDR/DR ELAS PWR (both) - AC1 or AC2 SPS THRUST - NORM SCS TVC (2) - RATE CMD (if burn is G&N or MTVC)	7 1	
or	SCS TVC (2) - AUTO (SCS burn) TVC GMBL DR (2) - AUTO		The 1 or 2 positions may be used as backup if required.
	ATVC GAIN - HI or LO		Required only for SCS/SPS auto thrusting. Position depends on whether auto or manual (tw) control of SPS gimbals desired. LO position provides proper response for tw control of SPS gimbals.
	FDAI/GPI PWR - 1, 2 or BOTH	7	Position chosen depends on whether redundant GPI displays desired. To enable redundant GPI indicators, FDAI/GPI PWR switch must be set to BOTH.
	LV IND/GPI sw - GPI	1	Provides attitude information and power to ECDUs.
7.4.2	<u>SPS Gimbal Control</u>		Operating time limited depending on operating conditions. MN BUS TIE (2) must be on before gimbal motors started.
1	CMC Cont ISS - on (req), 8.1.3 CMC - on (req), 8.1.3 Servo loop activated (step 4) Gmb1 mot on SC CONT - CMC		

7.4.2

SPS GIMBAL CONTROL

NORMAL BACKUP

OPERATIONS HANDBOOK

STA/T STEP	PROCEDURE	PANEL	REMARKS
AC	LOGIC 2/3 PWR - on (up) THC - neut	7	Supplies power to SC 'ONT switch.
2	SCS Cont - AUTO Servo loop activated (step 4) Gmb1 mot on	1	Operating time is limited depending on operating conditions. MW BUS TIE (2) must be on before gimbal motors are started.
7	LOGIC 2/3 PWR - on (up)	7	Supplies power to SC CONT, BMAG MODE, SCS TVC, and THC CW switches.
	ELEC PWR - ECA or GDC/ECA BMAG PWR (both) - ON		Supplies power to control electronics. Rate and attitude sensors required.
1	BMAG MODE - ATT 1/RATE 2 .05 G sw - OFF (verify) SCS TVC (2) - AUTO IGN 2 logic sig present SC CONT - SCS THC - neut or SC CONT - CMC THC - CW	1	BMAGs in gyro assembly 1 will uncage if MAJ ATT switches at RATE CMD. If not, uncaging will occur when IGN 2 logic signal present. On (up) position not desirable (cages BMAGs). Provided by thrust control logic at engine on until 1 second after engine off.

SPS GIMBAL CONTROL

APOLLO-SOYUZ TEST PROJECT (ASTP)
OPERATIONS HANDBOOK

STA/T STEP	PROCEDURE	PANEL	REMARKS
AC 3	MTVC cont - RATE CMD/ACCEL CMD Servo loop activated (step 4) Gmb1 mot on	1	Stick integrator is enabled when IGN 2 logic signal is present. The IGN 2 logic signal present at SPS on until 1 sec after SPS - off, is provided by thrust control electronics.
	LOGIC 2/3 PWR - on (up)	7	Operating time is limited depending on operating conditions. MN BUS TIE A/B or C/D must be on before gimbal motors are started.
	SIG CONDR/DR BIAS PWR (both) - AC1 or AC2 ELEC PWR - ECA or GDC/ECA BMAG 2 PWR - ON (for RATE CMD) BMAG MODE (3) - ATT 1/RATE 2 or RATE 2 RHC PWR NORM (both) - AC/DC	1	Provides power for SC CONT, BMAG MODE, SCS TVC and THC - CW switches. Required for RCS jet on-off and MTVV TLM. Supplies power to RHCs and control electronics. Rate information required for RATE CMD MTVV.
	Rate Cmd a. SCS TVC (2) - AUTO SC CONT - SCS THC - CW		
	or b. SCS TVC (2) - RATE CMD SC CONT - SCS		
	or SC CONT - CMC THC - CW		

SPS GIMBAL CONTROL

7.4.2

NORMAL BACKUP

OPERATIONS HANDBOOK

STA/T STEP	PROCEDURE	PANEL	REMARKS
AC	Accel Cmd a. SCS TVC (2) - ACCEL CMD SC CONT - SCS or SC CONT - CMC THC - CW	1	
4	Servo Loop Activation a. Servo loop No. 1 TVC SERVO PWR 1 - AC1/MNA	7	Provides power to clutches and servo drive electronics. Alternate position of this switch (AC2/MNB) should be used only in the event of an AC1 bus failure to provide additional redundancy. AC1/MNA position should be used in all other cases to be compatible with dc power source for gimbal motors (dc MNA bus power).
	TVC GMBL DR (2) - 1 or TVC GMBL DR (2) - AUTO THC - neut GMBL MOT 1 - operating or TVC SERVO PWR 2 - OFF	1	No. 1 gimbal motor must be on with no overcurrent failure sensed.
		7	

SPS GIMBAL CONTROL

APOLLO-SOYUZ TEST PROJECT (ASTP)
OPERATIONS HANDBOOK

STA/T STEP	PROCEDURE	PANEL	REMARKS
AC	b. Servo loop No. 2 TVC SERVO PWR 2 - AC2/MNB	7	Alternate position of this switch (AC1/MNA) should be used only in the event of an AC2 bus failure to provide additional redundancy. AC2/MNB position should be used in all other cases to be compatible with dc power source for gimbals motors (dc MNB bus power).
	TVC GMBL DR (2) - 2	1	
	or TVC GMBL DR (2) - AUTO LOGIC 2/3 PWR - on (up) THC - CW	7	Provides power to THC - CW switch.
	or TVC GMBL DR (2) - AUTO GMBL MOT 1 - not operating	1	If No. 1 gimbal motor off or an overcurrent sensed, control transferred to No. 2 servo loop.
	7.4.3 <u>Thrust On-Off Control</u>		
	1 CMC Cont		
	ISS - on (req), 8.1.3		
	CMC - on (req), 8.1.3		
	SPS Gmb1 Cont (desired), 7.4.2		
	SC CONT - CMC		
	LOGIC 2/3 PWR - on (up)	7	To satisfy CMC control, THC must not be CW.
	SPS THRUST - NORM	1	Supplies 28 vdc to SC CONT switch. DIR ON will override CMC thrust-on control.
	ΔV THRUST A(B) - NORM		Guarded.

THRUST ON-OFF CONTROL

7.4.3

NORMAL BACKUP

APOLLO-SOYUZ TEST PROJECT (ASTP)
OPERATIONS HANDBOOK

STA/T STEP	PROCEDURE	PANEL	REMARKS
AC	Thrust on CMC eng on cmd (P40) Thrust off CMC eng off cmd (P40) or AV THRUST A &/or B - OFF	1	Guarded.
2	SCS Cont SPS Gmbl Cont (desired), 7.4.2 SC CONT - SCS or SC CONT - CMC THC - CW		This option may establish SCS MFVC mode depending on position of SCS TVC switches.
	LOGIC 2/3 PWR - on (up) SPS THRUST - NORM AV THRUST A(B) - NORM	7 1	Supplies 28 vdc to SC CONT switch. DIR ON will override SPS thrust control. Guarded.
	Thrust on AV ind - not zero THC - +X or DIR ULL pb - push		Required only if EMS FUNC in AV or AV TEST.
	THRUST ON pb - push Thrust off EMS FUNC - AV AV ind - zero		Guarded.
	or AV THRUST A &/or B - OFF		

THRUST ON-OFF CONTROL

APOLLO-SOYUZ TEST PROJECT (ASTP)
OPERATIONS HANDBOOK

STA/T STEP	PROCEDURE	PANEL	REMARKS
3	Dir Cont SPS Gmbl Cont (desired), 7.4.2		
AC	Thrust on AV THRUST A &/or B - NORM SPS THRUST - DIR ON	1	Guarded. Lever lock.
	Thrust off AV THRUST A &/or B - OFF		Guarded.
	7.5 OPTICS CONTROL		
	7.5.1 <u>Auto Optics Positioning</u>		Permits CMC control of optics.
1	The following are req ISS - on, & orient known, 8.1.3 & sec 13 CMC - on, 8.1.3 Opt - on, 8.1.4		
2	Establish CMC cont OPT ZERO - OFF OPT TELTRUN - SLAVE TO SXT OPT MODE - CMC	122	Required for SCT trunnion drive. Permits manual control of optics using optics hand control (OHC).
CP	7.5.2 <u>Manual Optics Control</u>		
1	The following are req Opt - on, 8.1.4		

MANUAL OPTICS CONTROL

7.5.2

NORMAL BACKUP

APOLLO-SOYUZ TEST PROJECT (ASTP)
OPERATIONS HANDBOOK

STA/T STEP	PROCEDURE	PANEL	REMARKS
CP 2	Establish man cont & sighting options Optics - MAN/DIR OPT ZERO - OFF OPT MODE - MAN OPT COUPLING - DIR or Optics - MAN/RSLV OPT ZERO - OFF OPT MODE - MAN OPT COUPLING - RSLV OPT TELTRUN - SLAVE TO SXT or 0° or 25° OPT SPEED - HI, MED or LO 7.5.3 <u>Manual Optics Drive</u>	122	Permits desired image motion in FOV. In DIRECT mode, OHC left, right motion drives optics shaft, while up, down motion drives trunnion. RSLV mode provides motion resolved into SC body coordinates. Motion appears to be target motion corresponding to direction of OHC movement. Provides zeroing of SCT trunnion axis. Provides greater scanning capability for star sightings. Set as desired. Permits manual optics operation (no power) using optics tool. Supplies power for condition lamps and reticle.
1	The following are req G/N LTS - AC1 or AC2 G/N OPT PWR - OFF	100	
2	Obtain opt tool from tool kit		

MANUAL OPTICS DRIVE

APOLLO-SOYUZ TEST PROJECT (ASTP)
OPERATIONS HANDBOOK

STA/T STEP	PROCEDURE	PANEL	REMARKS
CP	3 Perform man opt drive RETCL BRT tv - as req SHAFT - as desired TRUN - as desired	122 121	
	7.6 ENTRY MONITOR SYSTEM (EMS)		
	7.6.1 <u>AV Test & Null Bias Check</u>		
AC	1 Initial EMS prep EMS FUNC - OFF (verify) cb EMS (2) - close (verify) EMS MODE - STBY	1 8 1	Enables slewing of AV ind. 6.1.1.1, note 10.
	2 EMS FUNC - AV SET Adj alphanumeric: brightness (option) EMS MODE - NORM Set AV ind to +1586.8 fps		AV TEST checks AV circuitry.
	3 EMS FUNC - AV TEST SPS THRUST lt - on AV ind decr (10 sec) SPS THRUST lt .. out ≈ -0.1 fps on AV ind AV ind stops at -0.1 to -41.5 fps		
	4 EMS MODE - STBY		
	5 EMS FUNC - AV SET Slew AV ind to -100.0 fps		AV indicator zeroed to start accelerometer null bias check.

7.6.1
AV TEST & NULL BIAS CHECK

7.6.1

NORMAL/BACKUP

APOLLO-SOYUZ TEST PROJECT (ASTP)
OPERATIONS HANDBOOK

STA/T STEP	PROCEDURE	PANEL	REMARKS
AC	Report ΔV ind reading to STDN	1	Use 1 by STDN with data recorded in step 9 to calculate ΔV_c for use on next burn.
CP	6 CMC MODE - FREE (til meas complete) or EMAG MODE (3) - RATE 2 or MAN ATT (3) - ACCEL CMD		Inhibits auto RCS jet firings which could create ΔV 's during the bias measurement.
AC	7 EMS FUNC - ΔV (wait 5 sec)		Allows accelerometer time to stabilize before switching from STBY mode.
T=0	8 EMS MODE - NORM		
T-100 sec	9 EMS MODE - STBY Rcd ΔV ind & report to STDN If ΔV drift ≤ 1 fps, do not bias counter If ΔV drift > 1 fps but < 10 fps bias if desired		Acceleration < 0.01 fps ² . Acceleration > 0.01 fps ² but < 0.1 fps ² . Counter bias not required for SPS ΔV .
	If ΔV drift > 10 fps, EMS is no-go for all functions		Acceleration > 0.1 fps ² .
	<u>CAUTION</u> Do not turn EMS FUNC - OFF prior to ΔV , or null bias will be invalid.		

ΔV TEST & NULL BIAS CHECK

APOLLO-SOYUZ TEST PROJECT (ASTP)
OPERATIONS HANDBOOK

STA/T STEP	PROCEDURE	PANEL	REMARKS
7.6.2	<u>AV Setup</u>		Specifies required steps necessary to initialize EMS for monitoring AVs and to generate the SPS engine cutoff signal for SCS controlled SPS AVs.
AC	AV TEST & NULL BIAS CHECK (desired), 7.6.1 cb EMS (2) - close	8	
1	EMS MODE - STBY EMS FUNC - AV SET	1	
2	Set AV ind - req AV		
3	EMS FUNC - AV		6.1.1.1, note 10.

AV SETUP

7.6.2

NORMAL BACKUP

8.0 G&C GENERAL PROCEDURES

The procedures in this section involve both the G&N and SCS and are used most frequently during the orbital phase. Because they are fundamental to G&C operation, they are included or referenced in various forms in the more complex G&C procedures contained in sec 9 through sec 21.

Applicable G&C Reference Modes, sec 7, have been referenced throughout these procedures.

For general G&C operating data, refer to operating notes, 6.1.

8.0

G&C GENERAL PROCEDURES

NORMAL/BACKUP

APOLLO-SOYUZ TEST PROJECT (ASTP)
OPERATIONS HANDBOOK

STA/T STEP	PROCEDURE	PANEL	REMARKS
8.1	G&N GENERAL		
8.1.1	<u>(P00) CMC Idling Program</u>		Indicates that CMC in operate condition but not performing control or computation operations requiring coordination with other crew tasks.
CP	Key V37E 00E DSKY - P00	2,140	Maintains CMC in readiness for entry into most programs. CSM and Soyuz state vectors and W-matrix (rendezvous) are updated. (Refer to 5.6.12 of R-693, section 5.)
8.1.2	<u>CMC/IMU Power Down</u> <u>(P06) CMC Power Low</u>		Transfers CMC from operate to standby. V69E may be used to recover from an inadvertent entrance into P06. Otherwise, when P06 selected, CMC must be powered down to standby.
1	Key V37E 06E DSKY - P06		
2	FL V50 H25 00062 (CMC pwr down)		
	PRO (push till STBY lt - on) CMC blanks DSKY disp		

CMC/IMU POWER DOWN

APOLLO-SOYUZ TEST PROJECT (ASTP)
OPERATIONS HANDBOOK

STA/T STEP	PROCEDURE	PANEL	REMARKS
	<u>IMU Power Down</u>		Transfers IMU from operate to standby.
AC 1	CMC MODE - FREE	1	
CP 2	G/N IMU PWF - OFF	100	Guarded. Loss of IRIG wheel power will send IMU FAIL discrete to CMC. 5 minutes should be allowed between IMU power down and ISS startup to permit gyro rundown prior to re-applying power (minimizes possibility of damaging gyros).
3	If CMC operating Key V37E XXE	2,140	Select program not requiring IMU.
	<u>CAUTION:</u>		
	Only in case of emergency shall IMU be powered down beyond stby:		If standby power removed for >20 minutes, ISS calibration no longer valid.
DP	cb G/N IMU HTR (2) - open	5	
	8.1.3 <u>Startup</u>		Transfers ISS/CMC from standby to operate condition. Startup procedure will be first procedure selected after returning from standby, since time 2/time 1 is invalid until this is done.
	<u>CMC Startup</u>		
	C/W INPUT LOC - ENBL (verify)	201	Enables C/W input to CMC warning light (panel 2).
CP	PRO - (push until STBY lt out) Poss CMC warning lt (20 sec max) Poss RESTART lt - on Poss PROG alarm RSET DSKY - P06 FL V37 Key OCE	2,140	When PRO released, CMC may revert to STBY mode. Repeat PRO until STBY light out. These alarms should be ignored if they can be reset.

8.1.3

STARTUP

NORMAL BACKUP

APOLLO-SOYUZ TEST PROJECT (ASTP)
OPERATIONS HANDBOOK

STA/T STEP	PROCEDURE	PANEL	REMARKS
SPT	If state vctr update Key V96E Perform CSM - (P27) CMC Update, 8.1.5 Key V37E OOE Key V37E XXE <u>ISS Startup</u>	2,140	V96E suspends state vector integration. Re-enables P00 integration suspended by V96E. 5 minutes should be allowed between IMU power down and ISS startup to permit gyro rundown prior to re-applying power (minimizes possibility of damaging gyros). Enables C/W input to ISS warning light (panel 2). Guarded. 15 seconds allows PIPA inhibit reset. Select IMU alignment program desired.
CDR	If CMC on C/W INPUT 10D - ENBL (verify) G/N IMU PWR - on (up) NO ATT It - on (90 sec) NO ATT It - out (wait 15 sec) Key V37E XXE If CMC not on G/N IMU PWR - on (up) wait 90 sec IMU CAGE - on (up) ≈ 5 sec then off (down)	201 100 2,140	Guarded. IMU drives to 0,0,0. Guarded. Releases IMU.
SPT	8.1.4 <u>Optics Power Control</u> 1 Opt pwr up G/N LTS - AC1 or AC2 OPT ZERO - OFF OPT MODE - MAJ G/N OPT PWR - on (up) OHC - drive trun <10° OPT ZERC - ZERO (=15 sec to zero) COND LAMPS - ON RETCL BRT tw - adj	100 122 100	6.1.3, note 4g. Provides power to reticle and condition lights in LEB. OPT ZERO switch should be left at ZERO until optics use required. It is not position of this switch, but change to ZERO position that triggers zeroing routine.

OPTICS POWER CONTROL

APOLLO-SOYUZ TEST PROJECT (ASTP)
OPERATIONS HANDBOOK

STA/T STEP	PROCEDURE	PANEL	REMARKS
CP	2 Opt pwr down OHC - drive trun <10° OPT ZERO - ZERO G/N OPT PWR - OFF G/N LTS - OFF	122 100	6.1.1.3, note 4g. Removes power from reticle and condition lights in LEP.
	8.1.1.5 (P27) CSM - CMC Update		
	CMC - on (req), 8.1.1.3 If P00, P02, P20 (opt 1, 2, 5) or V96E Go to 1		P27 may be entered only from P00, P02, P20 (options 1, 2, 5), or after V96E.
	If other Key V96E	2,140	
	or Key V37E 00E		
	<u>Auto Update</u>		
	1 UP TLM CM - ACPT UP TLM - ACPT UPLINK ACTY lt - on	2 122	
	2 Update complete UPLINK ACTY lt - out DSKY P00/P02/P20 UP TLM CM - BLOCK	2,122 2	

8.1.5

(P27) CSM - CMC UPDATE

NORMAL/BACKUP

APOLLO-SOYUZ TEST PROJECT (ASTP)
OPERATIONS HANDBOOK

STA/T STEP	PROCEDURE	PANEL	REMARKS
CP	<p>cr UP TLM - BLOCK</p> <p><u>Voice Transmission Update</u></p> <p>1 Liftoff time - V70E</p> <p>or Load data block - V71E</p> <p>cr Load singular data - V72E</p> <p>or Oct time increment - V73E</p> <p>Poss OPR ERR</p> <p>2 DSKY - P27</p> <p>3 FL V21 N01 R1 Blank R2 Blank R3 AAAAA</p> <p>Key in update data, XXXXXE (R1) CMC increments R3 by 1</p> <p>Repeat 3 until all data loaded</p> <p>4 FL V21 N02 R1 Blank R2 Blank R3 00330</p>	122	<p>If another extended verb active.</p> <p>P27 may be terminated by responding to flashing display with V34E. Data will not be incorporated for use by CMC.</p>
		2,140	

(P27) CSM - CMC UPDATE

APOLLO-SOYUZ TEST PROJECT (ASTP)
OPERATIONS HANDBOOK

STA/T STEP	PROCEDURE	PANEL	REMARKS
CP	<p>Accept update V33E P00, P02 or P20 - sel auto If V96 previously keyed Key V37E OOE Reject update Load Oct ID (XXE) of word to be corrected Return to 3</p> <p><u>Time Update (Decimal)</u></p> <p>1 Key V55E Poss OPR ERR</p> <p>2 FL V21 N24 (V25) Δ time (CMC clock) 00XX. HRS 00XX. MIN 0XX.XX SEC</p> <p>Accept Load ΔT Reject V33E or V34E</p> <p>3 Check Updated CMC Time Key V06 M65E Key V37E OOE</p>	2,140	<p>6.1.3, note 3m. Data transferred from buffer storage to appropriate cells Reinstates periodic P00 integration.</p> <p>If another extended verb active. All registers initially blank. Delta time change must all be provided in decimal. CMC adds ΔT to CMC clock time. 6.1.3, note 3m. V33E or V34E does not update clock time.</p> <p>DSKY displays R1, R2, R3 for crew verification. CMC returns to P00.</p>

6.1.5

(P27) CSM - CMC UPDATE

NORMAL/BACKUP

APOLLO-SOYUZ TEST PROJECT (ASTP)
OPERATIONS HANDBOOK

STA/T STEP	PROCEDURE	PANEL	REMARKS
CP	<p><u>Erasable Memory Update</u></p> <p>1 Key V37E 00E</p> <p>2 For Consecutive Address V21 M01E Load first address XXXXE Load first data word XXXXE N15E Verify CMC increments address by one (R3) Load second data word XXXXE,E Load third data word XXXXE,E Continue until last address in seq filled</p> <p>3 For Non-consecutive Address V21 M01E Load first address XXXXE Load first data word XXXXE,E Load second address XXXXE Load second data word XXXXE,F</p> <p>4 To Monitor Data Loaded in Consecutive Address V01 M01E Load first address XXXXE Check first data word in R1 N15E Check second data word in R1 ENTR Check third data word in R1 ENTR</p>	2,140	

(P27) CSM - CMC UPDATE

APOLLO-SOYUZ TEST PROJECT (ASTP)
OPERATIONS HANDBOOK

STA/T STEP	PROCEDURE	PANEL	REMARKS
CP 5	To Monitor Data Loaded in Non-consecutive Address V01 NOLE Load first address in R3 XXXXE Check first data word in R1 ENTR Load second address in R3 XXXXE Check second data word in R1 ENTR	2,140	
	8.1.6 (P47) G&N Thrusting Monitor Program		Monitors vehicle acceleration during non-G&N controlled thrusting maneuvers, and displays AV applied to vehicle by thrusting maneuver. Selection of P47 during P20 destroys least significant half of N78 (R1). Refer to P20, 10.2.1.
1	Key V37E 47E	2	G&N monitor of AV highly desirable, if available, but not a requirement. P47 should be called just prior to thrusting and terminated as soon as possible thereafter in order to minimize errors of bias and average G. Range, range rate, and theta may be displayed by using V83 (R31). Range, range rate, and phi may be displayed during P47 by using V85 (R34). Orbital parameters may be displayed by using V82 (R30). Also, an SCC orbit change can be monitored by P40 if properly combined with G&N Prethrusting and Thrusting Procedures, sec 11 and sec 12. N62 (VI, H dot, H) available during P47. R02.
	Poss PROG alarm (8.1.15)		

6.1.6

(P47) G&N THRUSTING MONITOR PROGRAM

NORMAL/BACKUP

APOLLO-SOYUZ TEST PROJECT (ASTP)
OPERATIONS HANDBOOK

STA/T STEP	PROCEDURE	PANEL	REMARKS
CP 2	FL V16 N83 ΔVX, Y, Z (cont) XXXX.X FPS	2	Displayed when average G turned on. CMC requires 12.5 seconds to turn on average G if integration required is < a time step plus 1.4 seconds for each additional time step. Time step = 240 seconds.
	(To rezero registers - V32E)		Provides capability to monitor another burn without going through R00.
	Monitor for burn completion Rcd ΔV PRO (exit P47)		When P47 termination desired.
3	FL V37 Key XXE		If average G on, R00 turns off average G. It also sets or resets RNDVZFLG, TRACK, and UPDATE flags, depending on which programs in progress or called, and may also recycle into P20.
	8.1.7 (P48) Rendezvous Thrust Monitor		Monitors vehicle acceleration during non-G&N controlled thrusting maneuvers, and displays ΔV applied to vehicle by thrusting maneuver. The program also displays range and range rate (R & R dot) from a source independent of vehicle state vectors (i.e., VHF, R27), and provides the opportunity to specify a time at which R & R dot will be optimized by loading N72 with the desired time.
	1 If MINKEY auto call Go to 2		P48 should be called just prior to thrusting (allow time for R27 convergence) and terminated as soon as possible thereafter in order to minimize errors of bias and average G.
	or Key V37E 48E	2,140	

(P48) RENDEZVOUS THRUST MONITOR

APOLLO-SOYUZ TEST PROJECT (ASTP)
OPERATIONS HANDBOOK

STA/T STEP	PROCEDURE	PANEL	REMARKS
CP	<p>Poss PROG alarm (8.1.15)</p> <p>2 FL V16 N77</p> <p>R XXX.XX MM</p> <p>R dot (- closing) XXXX.X FPS</p> <p>θ XXX.XX DEG</p> <p>Accept PRO, go to 4</p> <p>Reject V32E</p> <p>If N72 = 0, recycle 2</p> <p>If N72 ≠ 0, go to 3</p>	2,140	<p>Range, range rate, and theta/phi (as calculated from state vectors) may be displayed during P48 by using V83 (R31) and V85 (R34) respectively. Additionally, orbital parameters may be displayed by using V82 (R30).</p> <p>Optimization time [T (R27 optimized) in N72] is initialized to zero (for current time) and may be changed by V25 N72E and loading desired time (step 2).</p> <p>R02.</p> <p>VHF range to Soyuz.</p> <p>Range rate.</p> <p>Angle between CSM +X and local horizontal plane (0 to 360°). P48 initializes θ to -00001.</p> <p>Reinitializes N83 cells. N77 current/optimized values are defined as follows: If N72 = 0; R, R dot, & θ = current values. If N72 ≠ 0.</p> <p>-01B35 < TFO < +00B02, R & R dot = fixed at last current value.</p> <p>+00B02 < TFO < +01B35, R & R dot = optimizing values.</p> <p>TFO > 01B35, R & R dot = optimized values.</p> <p>TFO < -00B20, θ = current value.</p> <p>-00B20 < TFO < +00B02, θ = -00001.</p> <p>TFO > +00B02, θ = optimized value.</p> <p>New optimization is done every 4 minutes.</p>

8.1.7

(P48) RENDEZVOUS THRUST MONITOR

NORMAL/BACKUP

APOLLO-SOYUZ TEST PROJECT (ASTP)
OPERATIONS HANDBOOK

STA/T STEP	PROCEDURE	PANEL	REMARKS
CP	To optimize N77 values Key V25 N72E T (R27 optimized)	2,140	Initialized zero upon P48 entry. GET at which optimized R, R dot & θ desired.
3	Load desired optimization time V32E, go to 3 3 FL V16 N76	OOOX. HRS OOOXX. MIN OXX.XX SEC	For TFO (-01B35 < TFO < +01B35), R & R dot are being optimized, otherwise R & R dot are current values.
R	R dot (- closing)	XXX.XX NM XXXX.X FPS	VHF range to Soyuz. Range rate.
TFO	Accept PRO, return to 2 Reject V32E, recycle 3	XXBXX MIN-SEC	Time from optimization (determined by N72). +59B59 if no optimization requested.
4	FL V16 N83 ΔVX, Y, Z (cont)	XXXXX.X FPS	Reinitializes N83 cells.
Accept PRO, go to 5	Reject V32E		Initially zero. Updated at 2-second intervals.
If N72 = 0, return to 2	If N72 ≠ 0, return to 3		To re-initialize N83.
5	FL V37 Key XXE		

(P48) RENDEZVOUS THRUST MONITOR

APOLLO-SOYUZ TEST PROJECT (ASTP)
OPERATIONS HANDBOOK

STA/T STEP	PROCEDURE	PANEL	REMARKS
6.1.8	<u>CMC Self-Check Procedure</u>		Procedure used to check CMC's ability to write into and read out of erasable memory and performs internal fixed memory banksum.
CMC - on (req), 8.1.3		2,140	Zero self-check cells: ERCOUNT, SCOUNT, SCOUNT +1.
CF 1	Key V25 N01E 1365E E, E, E		Begin monitor of self-check cells.
2	Key V15 N01E - establish monitor of self-check 1365E		Starts complete self-check.
3	Key V21 N27E 10E - starts self-check		Turns off self-check.
4	Monitor R2 & PROG It		
a.	R2 becomes >3 Self-check has been successfully completed at least once Key V21 N27E OE terminates self-check		
b.	If PROG It comes on Coord with STDN &/or perform G/N malfunc SSR-1		
8.1.9	<u>Measurement and Loading of PIPA Bias</u>		ISS should be on at least one hour prior to performing this procedure to allow PIPAs to stabilize.
CMC - on (req), 8.1.3			
ISS - on (req), 8.1.3			

MEASUREMENT AND LOADING OF PIPA BIAS

8-13

NORMAL BACKUP

APOLLO-SOYUZ TEST PROJECT (ASTP)
OPERATIONS HANDBOOK

STA/T STEP	PROCEDURE	PANEL	REMARKS
AC	SCS - on (desired), 8.4.2 CMC ATT - IMU (verify) .05 G sw - CFF (verify) LOGIC 2/3 PWR - on (up)	1 7 1	Provides display and SCS control capability.
AC,CP 00:00	1 Set Evnt Tmr 00:00 2 Sel Att Cont desired, 7.1 Maintain SC Rates <0.1°/sec		
CP 01:04	3 Key V25 N21E, E, E, E/start Evnt Tmr 4 Key V06 N21 (do not ENTR) 5 Key ENTR	2,140	Zeros noun 21 cells.
	6 Rcd PIPA counts (X)R1 (Y)R2 (Z)R3 +XXXAB		If PIPA count > 99 (XXX#000), CMC incapable of adjusting PIPA bias.
	7 Key V21 N01E (adj PIPA bias) Load 1452E (calculated X bias) +AB000E, E 1454E (calculated Y bias) +AB000E, E 1456E (calculated Z bias) +AB000E		
	8 Key V37E 00E		

MEASUREMENT AND LOADING OF PIPA BIAS

APOLLO-SOYUZ TEST PROJECT (ASTP)
OPERATIONS HANDBOOK

STA/T STEP	PROCEDURE	PANEL	REMARKS																																
5.1.1.10	<u>ΔR and ΔV Threshold Change Procedure</u>																																		
	CMC - on (req), 8.1.3	2,140																																	
ΔR	Key V24 NO1E Key 2002E																																		
	Load erasable value for desired ΔR (from following table)																																		
	Load erasable value for desired ΔV (from following table)																																		
	<table border="1" data-bbox="899 1244 1252 1921"> <thead> <tr> <th>Desired ΔR MM</th> <th>Erasable Value</th> <th>Desired ΔV FPS</th> <th>Erasable Value</th> </tr> </thead> <tbody> <tr> <td>0.00</td> <td>77776</td> <td>0.00</td> <td>77776</td> </tr> <tr> <td>0.001</td> <td>0</td> <td>0.0001</td> <td>0</td> </tr> <tr> <td>0.1</td> <td>6</td> <td>2.5</td> <td>1</td> </tr> <tr> <td>0.2</td> <td>14</td> <td>5.12</td> <td>2</td> </tr> <tr> <td>0.3</td> <td>21</td> <td>7.68</td> <td>3</td> </tr> <tr> <td>0.4</td> <td>27</td> <td>10.24</td> <td>4</td> </tr> <tr> <td>0.5</td> <td>35</td> <td></td> <td></td> </tr> </tbody> </table>	Desired ΔR MM	Erasable Value	Desired ΔV FPS	Erasable Value	0.00	77776	0.00	77776	0.001	0	0.0001	0	0.1	6	2.5	1	0.2	14	5.12	2	0.3	21	7.68	3	0.4	27	10.24	4	0.5	35				
Desired ΔR MM	Erasable Value	Desired ΔV FPS	Erasable Value																																
0.00	77776	0.00	77776																																
0.001	0	0.0001	0																																
0.1	6	2.5	1																																
0.2	14	5.12	2																																
0.3	21	7.68	3																																
0.4	27	10.24	4																																
0.5	35																																		

ΔR AND ΔV THRESHOLD CHANGE PROCEDURE

5.1.1.10

NORMAL BACKUP

APOLLO-SOYUZ TEST PROJECT (ASTP)
OPERATIONS HANDBOOK

STA/T STEP	PROCEDURE	PANEL	REMARKS																		
6.1.1.11	<p><u>Flagword Monitor and Change Procedure</u></p> <p>Flagword Monitor</p> <p>Key V10 N01E Key XXXE (flagword address)</p> <p>R1 XXXXX (flag bit) R3 OXXXX (flagword address)</p> <p>Check flag bit in R1 KEY REL</p> <p>Flagword Change</p> <p>Key V25 N07E Key XXXE (flagword address)</p> <p>Key XXXXE (bit ID) Key 1 or 0 (1 = set flag bit, 0 = reset flag bit)</p>	<p>2,140</p>	<p>5.9 for flagword addresses.</p> <p>ECADR <30 (octal) will select appropriate channel (except that channel 7 attempts will be ignored).</p> <p>Load code for bit to be changed (bit ID) as follows:</p> <table border="1" data-bbox="264 1305 370 1437"> <tr> <td></td> <td>A</td> <td>B</td> <td>C</td> <td>D</td> <td>E</td> </tr> <tr> <td>Bit</td> <td>15 14 13</td> <td>12 11 10</td> <td>9 8 7</td> <td>6 5 4</td> <td>3 2 1</td> </tr> <tr> <td>code</td> <td>4 2 1</td> <td>4 2 1</td> <td>4 2 1</td> <td>4 2 1</td> <td>4 2 1</td> </tr> </table>		A	B	C	D	E	Bit	15 14 13	12 11 10	9 8 7	6 5 4	3 2 1	code	4 2 1	4 2 1	4 2 1	4 2 1	4 2 1
	A	B	C	D	E																
Bit	15 14 13	12 11 10	9 8 7	6 5 4	3 2 1																
code	4 2 1	4 2 1	4 2 1	4 2 1	4 2 1																

FLAGWORD MONITOR AND CHANGE PROCEDURE

APOLLO-SOYUZ TEST PROJECT (ASTP)
OPERATIONS HANDBOOK

STA/T STEP	PROCEDURE	PANEL	REMARKS
01	<p>Example:</p> <p>To set REFSMFLG (flagword 3, bit 13) Key V25 N07E 77E 10000E 1E</p> <p>3.1.12 Chan 31/33 Control Mode Override (C31FLWRD)</p>		<p>Provides flexibility for crew to specify desired control mode (via C31FLWRD) if, because of hardware failure, SC CONT, CMC MODE, OPT MODE, and OPT ZEPS switch position changes are not recognized by CMC. C31FLWRD is an erasable memory cell of the form AXXDX and must be manually loaded; A & D preferably padloaded zero. Used by CMC to determine whether channel 31 and 33 representation of control switch configurations are to be used, or if backup indicators are to be used.</p> <p>A = 0 or 4 (Chan 31 bits 13, 14, 15 = valid control mode representation). D = 0 or 4 (Chan 33 bits 4, 5 = valid control mode representation).</p>

CHAN 31/33 CONTROL MODE OVERRIDE (C31FLWRD)

NORMAL/BACKUP

APOLLO-SOYUZ TEST PROJECT (ASTP)
OPERATIONS HANDBOOK

STA/T STEP	PROCEDURE	PANEL	REMARKS
	<p>Load A (or B) E/J option in R1 EWTF</p>	<p>2,140</p>	<p>A or D ≠ 0 or 4 (CMC uses A or D as backup indicator of desired control mode as loaded in P1 from the following):</p> <p>Digit A backup option: 1 - G&N control PRPE 2 - G&N control ATT HCLD 3 - G&N control AUTO 5 - } SCS control modes 6 - } 7 - }</p> <p>Digit D backup option: 1 or 5 - OPT mode CMC 2 or 6 - OPT mode ZFR0 3 or 7 - OPT mode MAN</p>
8.1.13	<p><u>G&N Passive Thermal Control Procedure</u></p> <p>CMC - on (req), 8.1.3 ISS - on & orient known (req), 8.1.3 & Sec 13 RCS DAP - Load & activate (req), 8.2.1</p> <p>1 Perform (V49E) P62, 8.3.4 (PRO on auto mnvr req, FL V50 N18)</p>		<p>Nominal G&N PTC and orb rate capabilities contained in Universal Tracking (P20) procedures, 10.2.1. For SCS passive thermal control procedures, refer to 8.4.9 and 10. Refer to 8.2.5 for PTC (P20 option 2) procedures.</p> <p>0.5° deadband and 0.2°/second rate recommended.</p> <p>This option required to ensure erasable memory is properly set up.</p>

G&N PASSIVE THERMAL CONTROL PROCEDURE

APOLLO-SOYUZ TEST PROJECT (ASTP)
OPERATIONS HANDBOOK

STA/T STEP	PROCEDURE	PANEL	REMARKS	
AC CF	2 Disable two adjacent RCS quads Att hold for 20 min	8	Provides fuel conservation and lower rates (panel 8 switches or R03 may be used to disable engines).	
AC	3 MAN ATT P&Y (2) - ACCEL CMD Enable all RCS jets	1 6		
CF	4 Set att hold Key V21 NO1E 1330E, E (Set HOLDFLAG zero)	2,140	Sets HOLDFLAG zero and inhibits maneuver until after data load.	
	Establish desired rate			
	+0.1°/sec	-0.1°/sec	+0.3°/sec	-0.3°/sec
	V24 NO1E 3154E 3E 24400E V21E 3227E 35101E	V24 NO1E 3154E 77774E 53400E V21E 3227E 42676E	V24 NO1E 3154E 12E 35400E V24E 3226E 2E 27303E	V24 NO1E 3154E 77765E 42400E V24E 3226E 77775E 50474E
5	Start roll mnvr Key V21 NO1E 1330E 70000E		Initiates maneuver.	
AC	6 MAN ATT ROLL - ACCEL CMD	1	Disables roll jets for duration of PTC.	
CF	7 Perform FCC DAP Att Dbd Change, 8.2.3		+30° deadband is recommended.	

8.2.3

G&N PASSIVE THERMAL CONTROL PROCEDURE

NORMAL BACKUP

APOLLO-SOYUZ TEST PROJECT (ASTP)
OPERATIONS HANDBOOK

STA/T STEP	PROCEDURE	PANEL	REMARKS
AC	C AUTO RCS (16) - OFF	1	Re-establishes attitude hold within attitude deadband selected in P03.
9	To term PTC MAN ATT (3) - ACCEL CMD (verify) AUTO RCS (16) - MCA or MIE V46E or Cycle SC COMT sw MAN ATT (3) - RATE CMD	6	
1	b.1.1.4, Saturn Rate Charge	1	
	CMC - on (req), b.1.3	2,140	
CP	1 Key V24 NOLE 3342E XXXXE YYYYYE	2,140	
	SIVB RATE		
	0.05°/sec RPY	161	SAT RATE +1 (3342)
	0.1°/sec RPY	210	SAT RATE +2 (3343)
	0.2°/sec RPY	266	YYYYY
	0.3°/sec RPY	344	
	0.5°/sec R, P 0.3°/sec P&Y	476	
		77616	
		77567	
		77511	
		77433	
		77301	

SATURN RATE CHANGE

APOLLO-SOYUZ TEST PROJECT (ASTP)
OPERATIONS HANDBOOK

STA/T STEP	PROCEDURE	PANEL	REMARKS
6.1.15	<u>(R02) IMU Status Check</u>		
1	ISS not on		Checks whether IMU aligned to an orientation known by CMC and, if not, whether it is on. R02 automatically called by programs requiring ISS. Provides for program alarms if ISS not on and/or IMU orientation unknown.
CF	PROG alarm FL V37 Key V05 N09E (to verify alarm) 00210 (ISS not on) Perform ISS turnon Key XXE	2,140	Occurs only if ISS not on. Alarm stored; must key V05 N09E to display alarm code.
2	ISS on but orientation unknown		Return to PXX at completion of ISS turnon.
	PROG alarm Key V05 N09E (to verify alarm) 00220 (IMU orient unknown) FL V37 Key XXE		Alarm stored; must key V05 N09E to display alarm code. RSET and KEY REL pressed when nature of problem determined. When CMC regains control, program cycles through R00, which may set or reset RMDVFLG, TRACK, and UPDATE flags, depending on which programs are in progress or called. Reinitiate desired program.

(R02) IMU STATUS CHECK

6.1.15

NORMAL BACKUP

APOLLO-SOYUZ TEST PROJECT (ASTP)
OPERATIONS HANDBOOK

START STEP	PROCEDURE	PANEL	REMARKS
8.1.17	<p>8.1.17 <u>Backup CMC Clock Initialization</u></p> <p>Key V47 099 Key V47 001E 00000E +99999E +99999E +99999 CLR, CLR, CLR 00000E 00000E 00000E If OPR ERR Start over If DSKY does not clear Repeat proced</p>	2,140	DSKY relay failure mode will cause an all-eights display on DSKY. Affects display capability of DSKY but will not affect input/output or control functions.

BACKUP CMC CLOCK INITIALIZATION

APOLLO-SOYUZ TEST PROJECT (ASTP)
OPERATIONS HANDBOOK

STA/T STEP	PROCEDURE	PANEL	REMARKS
8.2	DIGITAL AUTOPILOT (DAP)		
8.2.1	(V48) Undocked DAP Data Load (R03)		
	CMC - on (req), 6.1.3		For CMC control modes (CSM alone), DAP data load procedure is used to select rate, deadband, and quads. When under computer control, operating program will establish SC rates and attitude error deadbands, or crew may select other desired error deadbands via DSKY. In addition, crew has capability of selecting RCS quads for computer command of manual translation, attitude hold, or automatic and manual maneuvers. Also refer to 6.1.1, note 16.
1	Key V48E	2,140	Extended verb 48 program calls DAP data 1, 2, and 3 in sequential order. DAP data 1, 2, or 3 may also be displayed individually by using respective verb/noun combinations, i.e., V04 N46, V06 N47, or V06 N48.
2	FL V04 N46 R1 - A B C D E R2 - A B C D E Accept PRO Reject V24E load desired data		If quads A/C and B/D (4 jets) desired for +X translation, R1-B and R1-C may be set to 0,0, or 1,1. For operational considerations, R1-A codes 2 & 6 are referred to as (CSM & Soyuz) and (CSM & DM) respectively; however, the MIT software listing for these codes are (CSM & IM) and (CSM & IM ascent stg only). If A is failed, CMC assumes C is good. If B is failed, CMC assumes D is good.

Vehicle Config	Quad A C for X	Quad B D for X	Er Deadband	Rate Select
R1	0 = Fail A C 1 = Use A C	0 = Fail B D 1 = Use B D	0 = 1.05' 1 = 1.50'	0 = 0.05/sec 1 = 0.27/sec 2 = 0.51/sec 3 = 1.01/sec
R2	0 = Fail A C 1 = Use A C	0 = Fail B D 1 = Use B D	0 = Fail C 1 = Use C	0 = Fail D 1 = Use D

(V48) UNDOCKED DAP DATA LOAD (R03)

NORMAL BACKUP

APOLLO-SOYUZ TEST PROJECT (ASTP)
OPERATIONS HANDBOOK

STA/T STEP	PROCEDURE	PANEL	REMARKS
CP 3	FL V06 N47 CSM wt XXXXX. LBS	2,140	Value of mass used in non-DAP coding not updated unless vehicle configuration digit is 1. P40 reduces value for weight linearly, as function of SPS maneuver time. Maneuvers performed without using P40 could cause CMC's knowledge of weight to be compromised.
	Other vehicle wt Accept PRO Reject Key V21E, V22E or V24E Load correct data	XXXXX. LBS	This may be either the DM weight or the Soyuz weight if R03 is selected for control.
4	FL V06 N48 P Trim Y Trim Accept PRO - Return to prog in progress Reject Key V21E, V22E or V24E Load correct data	XXX.XX DEG XXX.XX DEG	If burn >0.42 second, trim values will be updated by CMC during burn. Do not load engine gimbal trim angles >9°.
5	To activate DAP		To be done first time DAP started or after fresh start.
AC CP	CMC MODE - FREE Key V46E 8.2.2 (V44) Docked DAP Data Load (R04) CMC - on (req), 8.1.3 1 Key V44E	1 2,140	Prevents inadvertent jet firings. Activates R03. For CMC control modes, DAP data load procedure is used to select rate, deadband, and jets. When under computer control, operating program will establish SC rates and attitude error deadbands, or crew may select other desired deadbands via DSKY. In addition,

(V44) DOCKED DAP DATA LOAD (R04)

APOLLO-SOYUZ TEST PROJECT (ASTP)
OPERATIONS HANDBOOK

STA/T STEP	PROCEDURE	PANEL	REMARKS																																																																																																																																												
CP 2	FL V05 N87 R1 - ABCDE (quad sel & cont) R2 - C0CDE (CH5FAIL) R3 - C0CDE (CH6FAIL) Accept PRO Reject Key V25E Load desired data (from following table)	2,140	crew has capability of selecting RCS jets for computer command of manual translation, attitude hold, or automatic and manual maneuvers. Included under the maneuver functions are the automatic tracking and universal pointing options of P20. Also refer to 6.1.1.1, notes 16 and 17. If A/C used for X translation, force control preference should be specified for pitch. If B/D used, force control preference should be specified for yaw. Figure 6-13 describes jet selection options for torque couples or force pairs when docked CSM controlled maneuvers are desired.																																																																																																																																												
<table border="1"> <thead> <tr> <th colspan="2">A</th> <th colspan="2">B</th> <th colspan="2">C</th> <th colspan="2">D</th> <th colspan="2">E</th> </tr> <tr> <th colspan="2">Roll Control</th> <th colspan="2">Quad A D for X</th> <th colspan="2">Quad B D for X</th> <th colspan="2">Pitch Control</th> <th colspan="2">Yaw Control</th> </tr> <tr> <th>0 Fail</th> <th>1 Use</th> <th>0 Fail</th> <th>1 Use</th> <th>0 Fail</th> <th>1 Use</th> <th>0 Torque couple</th> <th>1 Force</th> <th>0 Torque couple</th> <th>1 Force</th> </tr> </thead> <tbody> <tr> <td colspan="10" style="text-align:center">INHIBIT JETS</td> </tr> <tr> <td colspan="10" style="text-align:center">CHANNEL 5 (PITCH & YAW)</td> </tr> <tr> <td colspan="2">B4</td> <td colspan="2">C3</td> <td colspan="2">D4</td> <td colspan="2">D3</td> <td colspan="2">A3</td> </tr> <tr> <td colspan="2">0 Inhibit</td> <td colspan="2">0 Inhibit</td> <td colspan="2">0 Inhibit</td> <td colspan="2">0 Inhibit</td> <td colspan="2">0 Inhibit</td> </tr> <tr> <td colspan="2">2 1</td> <td colspan="2">1</td> <td colspan="2">4 2 1</td> <td colspan="2">2 3 1</td> <td colspan="2">4 2 1</td> </tr> <tr> <td colspan="2">3 Inhibit</td> <td colspan="2">3 Inhibit</td> <td colspan="2">5 6 7 Inhibit</td> <td colspan="2">5 6 7 Inhibit</td> <td colspan="2">5 6 7 Inhibit</td> </tr> <tr> <td colspan="10" style="text-align:center">CHANNEL 6 (ROLL)</td> </tr> <tr> <td colspan="2">C2</td> <td colspan="2">C1</td> <td colspan="2">A2</td> <td colspan="2">A1</td> <td colspan="2">B2</td> </tr> <tr> <td colspan="2">0 Inhibit</td> <td colspan="2">0 Inhibit</td> <td colspan="2">0 Inhibit</td> <td colspan="2">0 Inhibit</td> <td colspan="2">0 Inhibit</td> </tr> <tr> <td colspan="2">2 1</td> <td colspan="2">1</td> <td colspan="2">4 2 1</td> <td colspan="2">2 3 1</td> <td colspan="2">4 2 1</td> </tr> <tr> <td colspan="2">3 Inhibit</td> <td colspan="2">3 Inhibit</td> <td colspan="2">5 6 7 Inhibit</td> <td colspan="2">5 6 7 Inhibit</td> <td colspan="2">5 6 7 Inhibit</td> </tr> </tbody> </table>				A		B		C		D		E		Roll Control		Quad A D for X		Quad B D for X		Pitch Control		Yaw Control		0 Fail	1 Use	0 Fail	1 Use	0 Fail	1 Use	0 Torque couple	1 Force	0 Torque couple	1 Force	INHIBIT JETS										CHANNEL 5 (PITCH & YAW)										B4		C3		D4		D3		A3		0 Inhibit		0 Inhibit		0 Inhibit		0 Inhibit		0 Inhibit		2 1		1		4 2 1		2 3 1		4 2 1		3 Inhibit		3 Inhibit		5 6 7 Inhibit		5 6 7 Inhibit		5 6 7 Inhibit		CHANNEL 6 (ROLL)										C2		C1		A2		A1		B2		0 Inhibit		0 Inhibit		0 Inhibit		0 Inhibit		0 Inhibit		2 1		1		4 2 1		2 3 1		4 2 1		3 Inhibit		3 Inhibit		5 6 7 Inhibit		5 6 7 Inhibit		5 6 7 Inhibit	
A		B		C		D		E																																																																																																																																							
Roll Control		Quad A D for X		Quad B D for X		Pitch Control		Yaw Control																																																																																																																																							
0 Fail	1 Use	0 Fail	1 Use	0 Fail	1 Use	0 Torque couple	1 Force	0 Torque couple	1 Force																																																																																																																																						
INHIBIT JETS																																																																																																																																															
CHANNEL 5 (PITCH & YAW)																																																																																																																																															
B4		C3		D4		D3		A3																																																																																																																																							
0 Inhibit		0 Inhibit		0 Inhibit		0 Inhibit		0 Inhibit																																																																																																																																							
2 1		1		4 2 1		2 3 1		4 2 1																																																																																																																																							
3 Inhibit		3 Inhibit		5 6 7 Inhibit		5 6 7 Inhibit		5 6 7 Inhibit																																																																																																																																							
CHANNEL 6 (ROLL)																																																																																																																																															
C2		C1		A2		A1		B2																																																																																																																																							
0 Inhibit		0 Inhibit		0 Inhibit		0 Inhibit		0 Inhibit																																																																																																																																							
2 1		1		4 2 1		2 3 1		4 2 1																																																																																																																																							
3 Inhibit		3 Inhibit		5 6 7 Inhibit		5 6 7 Inhibit		5 6 7 Inhibit																																																																																																																																							
<p style="text-align:right">Normally inhibited while docked to Soyuz</p> <p>To re-enable inhibited jets Key V59E</p> <p style="text-align:right">Re-enables all jets previously inhibited in R04.</p>																																																																																																																																															
<p style="text-align:right">(V44) DOCKED DAF DATA LOAD (R04)</p>																																																																																																																																															

3.2.2

NORMAL BACKUP

APOLLO-SOYUZ TEST PROJECT (ASTP)
OPERATIONS HANDBOOK

STA/T STEP	PROCEDURE	PANEL	REMARKS
CP 3	FL V06 N89 DAP rate DAP DBD Accept PRO (exit R04) Reject Key V21E, V22E or V24E Load correct data 4 To activate DAP CMC MODE - FREE Key V45E	X.XXXX DEG/SEC XXX.XX DEG 2,140	<p>To be done first time DAP started or after fresh start. In addition, V45E is necessary if R04 re-entered to change DAP deadband (N89).</p> <p>Prevents inadvertent jet firings. Activates DDAP and inhibits UDAP functions. P40 selected and V45E = OPR ERR. Once DDAP has been activated and attempt is made to fire jets, alarms 00500 and/or 00501 may occur. The alarms will not be repeated until R04 is again performed (flags associated with alarms are reset in R04, and set after DDAP activation if insufficient jets available for control of vehicle). R04 jet selection should be examined for sufficient jets enabled to allow DDAP to control vehicle.</p> <p>This procedure will change RCS DAP (UDAP) att deadband to +2.5, 10, 15, 20, 25, or 30°. Additional method of establishing desired deadbands is via N79 load in P20 procedures.</p>
8.2.3	<u>RCS DAP Attitude Deadband Change Procedure</u> CMC - on (req), 8.1.3 ISS - on (req) & orient known (desired), 8.1.3 & sec 13 RCS DAP - activate (req), 8.2.1 SCS - on (desired), 8.4.2 1 Sel CMC Att Cont - auto, 7.1.6 2 Sel 5.0° dbd in RCS LAP, 8.2.1		

RCS DAP ATTITUDE DEADBAND CHANGE PROCEDURE

APOLLO-SOYUZ TEST PROJECT (ASTP)
OPERATIONS HANDBOOK

STA/T STEP	PROCEDURE	PANEL	REMARKS														
CP 3	<p>Key V21 NO1E 3306E Load D Band (see table)</p> <table border="1"> <thead> <tr> <th>Desired dbd</th> <th>D Band</th> </tr> </thead> <tbody> <tr> <td>+2.5°</td> <td>0343E</td> </tr> <tr> <td>+10°</td> <td>1616E</td> </tr> <tr> <td>+15°</td> <td>2525E</td> </tr> <tr> <td>+20°</td> <td>3434E</td> </tr> <tr> <td>+25°</td> <td>4343E</td> </tr> <tr> <td>+30°</td> <td>5252E</td> </tr> </tbody> </table> <p>4 To return to 5.0° dbd THC - CW, then neut or Key V48E PRO PRO PRO</p> <p>8.2.4 RCS DAP Orbital Rate Procedure</p> <p>CMC - on (req), 8.1.3 ISS - on & orient known (req), 8.1.3 & sec 13 SCS - on (desired), 8.4.2 RCS DAP - load & activate (req), 8.2.1 Ysm aligned to $\underline{V} \times \underline{R}$ (If $\underline{R} \times \underline{V}$, complement numbers for ZZZZZ)</p> <p>1 Perform (V49) R62, 8.3.4 Load gmb1 angles for init of orbrate</p> <p>2 If desired Key V37E YXE (non-att cont prog)</p>	Desired dbd	D Band	+2.5°	0343E	+10°	1616E	+15°	2525E	+20°	3434E	+25°	4343E	+30°	5252E	2,140	<p>Center of deadband shifted. Center of deadband not affected.</p> <p>P20 (option 2) may be used to effect orb rate. P20 universal tracking (options 1 and 5) may be used, operationally, to produce a maneuver similar to orb rate. (These options provide a computed maneuver to maintain a specified body vector aligned with the LOS to the celestial body specified, as opposed to a "rate" type maneuver; e.g., option 2.) Refer to 8.2.6 for Orb Rate (P20 option 2) procedures.</p> <p>Gimbal angles loaded are those that are to be at initiation of orbital rate rotation (necessary to initialize erasable memory). MGA should be zero.</p>
Desired dbd	D Band																
+2.5°	0343E																
+10°	1616E																
+15°	2525E																
+20°	3434E																
+25°	4343E																
+30°	5252E																

RCS DAP ORBITAL RATE PROCEDURE

NORMAL BACKUP

APOLLO-SOYUZ TEST PROJECT (ASTP)
OPERATIONS HANDBOOK

STA/T STEP	PROCEDURE	PANEL	REMARKS
CP 3	Establish orbrate For rates 0.1°/sec or less, load oct numbers corresponding to desired mnvr rate from following table For rate 0.5°/sec, go to 5		
	Key V21 N01E 1330E,E (Set HOLDFLAG zero)	2,140	Sets HOLDFLAG to zero and inhibit maneuver until after data load.
	Key V24 N01E 3156E VVVVVE WWWWWE		
	Key V24E 3160E XXXXE YYYYE		
	Key V21E 3231E ZZZZE		
	Key V21E 1330E 70000E (Set HOLDFLAG negative)		Final ENTR initiates maneuver.
	Mnvr in progress		

RCS DAP ORBITAL RATE PROCEDURE

APOLLO-SOYUZ TEST PROJECT (ASTP)
OPERATIONS HANDBOOK

STA/T STEP	PROCEDURE				PANEL	REMARKS
4	To term mnvr, go to 8					
	CDUX					
ORBRATE deg/sec	0 deg	+90 deg	+180 deg	+270 deg		
-0.100	VVVV = 77774 WWWW = 54300 XXXX = 00000 YYYY = 61300 ZZZZ = 42676	00000 61300 00003 23500 42676	00003 23500 00000 16500 42676	00000 16500 77774 54300 42676		
-0.095	VVVV = 77774 WWWW = 62200 XXXX = 00000 YYYY = 62000 ZZZZ = 44250	00000 62000 00003 15600 44250	00003 15600 00000 16000 44250	00000 16000 77774 62200 44250		
-0.090	VVVV = 77774 WWWW = 70000 XXXX = 00000 YYYY = 62600 ZZZZ = 45622	00000 62600 00003 10000 45622	00003 10000 00000 15200 45622	00000 15200 77774 70000 45622		
-0.085	VVVV = 77774 WWWW = 75600 XXXX = 00000 YYYY = 63400 ZZZZ = 47173	00000 63400 00003 02200 47173	00003 02200 00000 24400 47173	00000 14400 77774 75600 47173		
					...continued	

FCS D/P ORBITAL RATE PROCEDURE

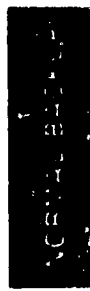

APOLLO-SOYUZ TEST PROJECT (ASTP)
OPERATIONS HANDBOOK

STA/T STEP	PROCEDURE				REMARKS
	CDUX				
	0 deg	+90 deg	+180 deg	+270 deg	
ORBRATE deg/sec					
-0.080	VVVV = 77775 WWWW = 43400 XXXXX = 00000 YYYYY = 64100 ZZZZZ = 50545	00000 64100 00002 34400 50545	00002 34400 00000 13700 50545	00000 13700 77775 43400 50545	
-0.075	VVVV = 77775 WWWW = 51300 XXXXX = 00000 YYYYY = 64700 ZZZZZ = 52117	00000 64700 00002 26500 52117	00002 26500 00000 13100 52117	00000 13100 77775 51300 52117	
-0.070	VVVV = 77775 WWWW = 57100 XXXXX = 00000 YYYYY = 65500 ZZZZZ = 53467	00000 65500 00002 20700 53467	00002 20700 00000 12300 53467	00000 12300 77775 57100 53467	
-0.065	VVVV = 77775 WWWW = 64700 XXXXX = 00000 YYYYY = 66300 ZZZZZ = 55041	00000 66300 00002 13100 55041	00002 13100 00000 11500 55041	00000 11500 77775 64700 55041	
	...continued				

RCS DAP ORBITAL RATE PROCEDURE

APOLLO-SOYUZ TEST PROJECT (ASTP)
OPERATIONS HANDBOOK

STA/T STEP	PROCEDURE				REMARKS
	CDUX				
ORBRATE deg/sec	0 deg	+90 deg	+180 deg	+270 deg	
-0.060	VVVVV = 77775	00000	00002	00000	
	WWWWW = 72500	67100	05300	10700	
	XXXXX = 00000	00002	00000	77775	
	YYYYY = 67100	05300	10700	72500	
	ZZZZZ = 56413	56413	56413	56413	
-0.055	VVVVV = 77776	00000	00001	00000	
	WWWWW = 40300	67600	37400	10200	
	XXXXX = 00000	00001	00000	77776	
	YYYYY = 67600	37400	10200	40300	
	ZZZZZ = 57765	57765	57765	57765	
-0.050	VVVVV = 77776	00000	00001	00000	
	WWWWW = 46200	70400	31600	07400	
	XXXXX = 00000	00001	00000	77776	
	YYYYY = 70400	31600	07400	46200	
	ZZZZZ = 61337	61337	61337	61337	
CP 5	Ysm aligned to V x R (If R x V, complement numbers for AAAAA and ZZZZZ)				2,140
6	Key V21 NO1E 1330E,E (set HOLDFLAG zero)				Sets HOLDFLAG zero and inhibits maneuver until after data load.

8.2.4
RCS DAP ORBITAL RATE PROCEDURE

APOLLO-SOYUZ TEST PROJECT

APOLLO-SOYUZ TEST PROJECT (ASTP)
OPERATIONS HANDBOOK

STA/T STEP	PROCEDURE	PANEL	REMARKS																																			
CP	7 Establish orbrate (0.5°/sec) Load oct numbers corresponding to mnvr rate from following table Key V24E 3156E VVVVVE WWWWWE Key V24E 3160E XXXXXE YYYYYE Key V24E 3230E AAAAAE ZZZZZE Key V21E 1330E 70000E (set HOLDFLAG negative)	2,140	Final ENTR initiates maneuver.																																			
CDUX																																						
	<table border="1"> <thead> <tr> <th></th> <th>0°</th> <th>180°</th> <th>7.25°</th> <th>187.25°</th> </tr> </thead> <tbody> <tr> <td>VVVVV</td> <td>77755</td> <td>00022</td> <td>77722</td> <td>00022</td> </tr> <tr> <td>WWWWW</td> <td>76077</td> <td>01700</td> <td>71351</td> <td>06426</td> </tr> <tr> <td>XXXXX</td> <td>77775</td> <td>00002</td> <td>---</td> <td>---</td> </tr> <tr> <td>YYYYY</td> <td>56367</td> <td>11410</td> <td>---</td> <td>---</td> </tr> <tr> <td>AAAAA</td> <td>77773</td> <td>77773</td> <td>77773</td> <td>77773</td> </tr> <tr> <td>ZZZZE</td> <td>55272</td> <td>55272</td> <td>56272</td> <td>56272</td> </tr> </tbody> </table>		0°	180°	7.25°	187.25°	VVVVV	77755	00022	77722	00022	WWWWW	76077	01700	71351	06426	XXXXX	77775	00002	---	---	YYYYY	56367	11410	---	---	AAAAA	77773	77773	77773	77773	ZZZZE	55272	55272	56272	56272		
	0°	180°	7.25°	187.25°																																		
VVVVV	77755	00022	77722	00022																																		
WWWWW	76077	01700	71351	06426																																		
XXXXX	77775	00002	---	---																																		
YYYYY	56367	11410	---	---																																		
AAAAA	77773	77773	77773	77773																																		
ZZZZE	55272	55272	56272	56272																																		

RCS DAP ORBITAL RATE PROCEDURE

APOLLO-SOYUZ TEST PROJECT (ASTP)
OPERATIONS HANDBOOK

STA/T STEP	PROCEDURE	PANEL	REMARKS
AC	S To term mnvr CMC MODE - HOLD	1	
CP	or Key V49E, return to 1 or Key V46E or RHC - out of detent or Key V37E 00E	2,140	
	8.2.5 <u>PTC (P20 option 2)</u> CMC - on (req), 8.1.3 ISS - on & orient known (req), 8.1.3 & sec 13 SCS - on (desired), 8.4.2 RCS DAP - load & activate (req), 8.2.1 CMC ATT - IMJ (verify) .05 G sw - OFF (verify) LOGIC 2/3 PWR - on (up)		Provides PTC maneuver by implementing P20 rotation (option 2). Also refer to 6.1.3, note 3r. Provides display and SCS control capability.
AC	1 RHC (2) - LOCKED FDAI SCALE - 5/1 2 Mnvr to PTC att Perform V49 (R62), 8.3.4	1	If SCS - on option not selected. Final ENTR in V49.
	When att satisfactory, damp vehicle rates Disable all jets on two adjacent quads		

8.2.5

PTC (P20 OPTION 2)

NORMAL BACK UP

APOLLO-SOYUZ TEST PROJECT (ASTP)
OPERATIONS HANDBOOK

STA/T STEP	PROCEDURE	PANEL	REMARKS
	Sel single jet (roll) compatible with LAP load Wait 20 min		
3	Configure RCS jets + Roll AUTO RCS A/C ROLL A1, C1 - MNA or MNB or AUTO RCS B/D ROLL B1, D1 - MNA or MNB - Roll AUTO RCS A/C ROLL A2, C2 - MNA or MNB or AUTO RCS B/D ROLL B2, D2 - MNA or MNB	8	To damp existing vehicle rates.
	AUTO RCS (remaining 12) - OFF MAN ATT ROLL - RATE CMD	1	
4	Perform P20 (option 2), 10.2.1		Load N78/N79 with desired PTC body vector, rate and deadband.
5	Disable RCS & terminate P20 AUTO RCS (16) - OFF RHC PWR DIR (2) - OFF (verify) V56E	8 1 2,140	Terminates P20.
6	To terminate mnvr CMC MODE - FREE AUTO RCS - as desired Verify P00 CMC MODE - AUTO (verify)	1 8 2,140 1	
AC			
CP			
AC			

PTC (P20 OPTION 2)

APOLLO-SOYUZ TEST PROJECT (ASTP)
OPERATIONS HANDBOOK

STA/T STEP	PROCEDURE	PANEL	REMARKS
8.2.6	Orb Rate (P20 option 2)		Provides orb rate maneuver by implementing P20 rotation (option 2). Also refer to 6.1.3, note 3r.
	CMC - on (req), 8.1.3		
	ISS - on & orient known (req), 8.1.3 & sec 13		
	SCS - on (desired), 8.4.2		Provides display and SCS control capability.
	RCS DAP - load & activate (req), 8.2.1		
	CMC ATT - IMU (verify)		
	.05 G sw - OFF (verify)		
	LOGIC 2/3 PWR - on (up)		If SCS - on option not selected.
AC	1 RHC (2) - LOCKED FDAI SCALE - 5/1		
2	Mnvr to orb rate att Perform V49 (R62), 8.3.4		Final EMIR in V49.
	When att satisfactory Damp vehicle rates		
	Sel single jet (roll) compatible with DAP load		
3	Configure RCS jets AUTO RCS - as desired MAN ATT (3) - RATE CMD	8 1	

ORB RATE (P20 OPTION 2)

8.2.6

NORMAL BACKUP

APOLLO-SOYUZ TEST PROJECT (ASTP)
OPERATIONS HANDBOOK

STA/T STEP	PROCEDURE	PANEL	REMARKS
	Perform P20 (option 2), 10.2.1		Load N78/N79 with desired orb rate body vector, rate and deadband.
5	To terminate mnvr RHC - out of detent	2,140	Terminates P20.
CF	or V56E		
	or Key V37E 00E		
AC	or SC CONF - SCS	1	

ORB RATE (P20 OPTION 2)

APOLLO-SOYUZ TEST PROJECT (ASTP)
OPERATIONS HANDBOOK

STA/T STEP	PROCEDURE	PANEL	REMARKS
8.3	EXTENDED VERBS		
8.3.1	<u>(V35) DSKY Condition Light Test</u>		Procedure designed to test CMC/caution and warning, DSKY interface.
CP	<p>CMC - on (req), 8.1.3</p> <p>1 Key V37E OOE (req)</p> <p>2 Key V35E</p> <p>3 Monitor the following events</p> <p>a. All DSKY condition lts - on</p> <p>b. ISS warning lt - on CMC warning lt - on MASTER ALARM lt - on</p> <p>c. All DSKY numerical windows disp 8 Sign positions in R1, R2, R3 show + V, N windows flash</p> <p>Wait 5 sec</p> <p>d. All DSKY warning lts - out (except PROG lt, if IMU on)</p> <p>e. ISS lt - out CMC lt - out Reset MASTER ALARM lt</p> <p>f. DSKY - P00 Interrupted disp (if any) will be restarted</p>	2,140	Must be performed while in P00.
			CMC lt on allows PIPAs to drift, generates alarm 00212 and may cause PIPA bias shift.
			NO ATT will be left on if coarse align occurring. PROG lt remains on for ≈10 seconds.

8.3.1

(V35) DSKY CONDITION LIGHT TEST

NORMAL BACK

APOLLO-SOYUZ TEST PROJECT (ASTP)
OPERATIONS HANDBOOK

STA/T STEP	PROCEDURE	PANEL	REMARKS
CP	<p>g. Wait 10 sec</p> <p>Key RSET</p> <p>8.3.2 (V42) Torque Gyros</p> <p>CMC - on (req), 8.1.3</p> <p>ISS - on (req) & orient known (desired), 8.1.3 & sec 13</p> <p>1 Key V37E 00E 2,140</p> <p>2 For Load <100° Key V42E</p> <p>Poss OPR ERR</p> <p>or For Load >99.999° Key V21 N02E</p> <p>2757E XXXXXE N15E XXXXXEE YYYYYEE YYYYYEE ZZZZZEE ZZZZZE Key V42E</p> <p>Poss OPR ERR</p> <p>3 FL V21 N93 (request load)</p>		<p>Because V35E removes power to PIPAs, 10 seconds should be allowed after V35 completion before the PIPAs are used.</p> <p>Unless in R3, clears fail registers of 00212 (PIPA fail) alarm.</p> <p>Fine aligns stable member by torquing gyros (primarily for ground use).</p> <p>If another extended verb active.</p> <p>Load >90 deg should not be performed during flight.</p> <p>If another extended verb active.</p> <p>If SC COMT at CMC and CMC MODE at AUTO or HOLD, DAP will maneuver vehicle to follow the platform as it moves.</p>

(V42) TORQUE GYROS

APOLLO-SOYUZ TEST PROJECT (ASTP)
OPERATIONS HANDBOOK

STA/T STEP	PROCEDURE	PANEL	REMARKS
CP	<p>Δ Gyro X, Y, Z XX.XXX DEG 2,140</p> <p>Accept Load desired data DSKY displays V42 NO ATT lt - out</p> <p>Reject V33E DSKY displays V42 NO ATT lt - out</p> <p>Poss OPR ERR</p>		<p>Registers initially blank.</p> <p>Key V33E if Gyro torquing registers loaded prior to keying V42E. Also refer to 6.1.3, note 3m.</p> <p>If IMU stall routine in use.</p>
8.3.3	<p><u>(V43) Load FDAI Error Needles</u></p> <p>CMC - on (req), 8.1.3 ISS - on (req), 8.1.3 RCS DAP - off</p>		<p>Loads crew specified angles into FDAI error needles (primarily for ground use).</p> <p>Prevents undesirable jet firing.</p> <p>V43E can be executed only from P00.</p>
1	Key V37E 00E		
2	Key V43E		<p>V43E cannot be executed if CMC not in P00, IMU in coarse align or zero ICDU mode, or if another extended verb active. (Latter is constraint after liftoff.)</p> <p>Registers initially blank.</p> <p>Maximum effective angle which may be loaded is +16.88 degrees.</p>
3	<p>FL V21 :22 (request load) XXX.XX DEG R, P, Y</p> <p>Load desired err angles</p>		

8.3.3

(V43) LOAD FDAI ERROR NEEDLES

NORMAL BACKUP

APOLLO-SOYUZ TEST PROJECT (ASTP)
OPERATIONS HANDBOOK

STA/T STEP	PROCEDURE	PANEL	REMARKS
8.3.4	(V49) CSM Crew Defined Maneuver (R62)		Provides method of performing CMC controlled maneuver to crew defined attitude.
AC	CMC - on (req), 8.1.3 ISS - on (req) & orient known (desired), 8.1.3 & sec 13 SCS - on (req), 8.4.2 CMC ATT - IMU (verify) .05 G sw - OFF (verify)	1	
CP	1 Key V37E OOE	2,140	Routine R62 may be called from P00 only.
2	Sel Tot Att (ISS) Disp, 7.2.5		Both FDAIs recommended so either reference system (IMU or GDC) may be monitored. (CMC attitude error and rate displays available.)
3	Key V49E		If another extended verb active.
4	FL V06 N22 (fnl gmb1 angles) R, P, Y XXX.XX DEG Accept PRO Reject V25E load desired gmb1 angles (R60 - Attitude Maneuver Routine)		Provides for maneuver (automatically or manually) to specified attitude. Required gimb1 angles.
5	FL V50 N18 (auto mmvr request) R, P, Y XXX.XX DEG		

(V49) CSM CREW DEFINED MANEUVER (R62)

APOLLO-BOYUZ TEST PROJECT (ASTP)
OPERATIONS HANDBOOK

STA/T STEP	PROCEDURE	PANEL	REMARKS
AC	Accept EMAG MODE (3) - RATE 2 Sel CMC Att Cont Auto, 7.1.6 PRO	1	May be performed second time as attitude trim.
CP	V06 N18 (auto mnvr) R, P, Y XXX.XX DEG Monitor auto mnvr on FDAI Recycle 5 Reject Key V62E	2,140	Non-flashing display until completion of auto maneuver then returns to FL V50 N18. Maneuver rates will be as specified by last DAP data load (R03/R04). Selects Mode 2, total attitude error on FDAI needles. Any input from RHC (RHC out of detent) will be interpreted by CMC as a manual override and will cause immediate termination of auto maneuver calculation and return to FL V50 N18. Exit R60/R62.
	When att satisfactory ENTR		Displays status of full track flag (FULTKFLG), and allows change by DSKY entry. Flag is examined only during auto W-matrix reinitialization following TPI (MINKEY) rendezvous sequence (TPIMNPLG set). FULTKFLG indicates whether full track (VHF and optics marks), or partial track (VHF or optics marks) will be used to update the state vector.
	CMC - on (req), 8.1.3		If another extended verb active.
	1 Key V57E		
	Poss OPR ERR		

(V57) FULL TRACK FLAG SPECIFICATION

8.3.5

NORMAL BACKUP

APOLLO-SOYUZ TEST PROJECT (ASTP)
OPERATIONS HANDBOOK

STA/T STEP	PROCEDURE	PANEL	REMARKS
CP 2	FL V04 N12 00004 (full track option) 0000X X = 1 (partial track) X = 0 (full track)	2,140	R2, current status of FULTKFLG. P20, VHF or optics marks (FULTKFLG set). P20, VHF and optics marks (FULTKFLG reset).
	Accept PRO (exit) Reject Key V22E Load desired option		Ensures desired flag setting.
	If priority disp appears after N12 load Key V32E		Get third N12 display.
	FL V04 N12 PRO (exit)		Displays the tracking angles corresponding to given optics angles, and automatically alters spacecraft tracking axis (as contained in N78) since R61 constructs the tracking vector from the contents of N78.
	8.3.6 (V64) Optics Angles Transform (R64)		If another extended verb in process.
	CMC - on (req), 8.1.3		
	1 Key V64E Poss OPR ERR Exit R64		
	2 FL V06 N94 SA TA		

(V64) OPTICS ANGLES TRANSFORM (R64)

APOLLO-SOYUZ TEST PROJECT (ASTP)
OPERATIONS HANDBOOK

STA/T STEP	PROCEDURE	PANEL	REMARKS
CP	Accept PRO 2,140 Reject Key V24E Load desired data 3 FL V06 N78 Y XXX.XX DEG P XXX.XX DEG Az XXX.XX DEG Accept PRO Reject Key V25E Load desired data 4 Return to prog in progress		If P20 active when this routine performed, the values displayed in N78 may be used for tracking. Each time MINKEY is initiated, N78 R1 and R2 will be overwritten. P20 yaw angle (gamma). P20 pitch angle (rho).
8.3.7	(V67) Start W-Matrix RSS Error <u>Display</u> CMC - on (req), 8.1.3 1 Key V67E Poss OPP EPR Exit 2 FL V06 N99 POS ERR XXXX. FT VEL ERR XXXX.X FPS		Provides display of RSS position and velocity errors, and opportunity to load new initialization values. However, initialization will not take place until next opportunity. If another extended verb in process. RSS value of position error. RSS value of velocity error.

8.3.7

(V67) START W-MATRIX RSS ERROR DISPLAY

NORMAL BACKUP

APOLLO-SOYUZ TEST PROJECT (ASTP)
OPERATIONS HANDBOOK

STA/T STEP	PROCEDURE	PANEL	REMARKS
CP	Option code 0000X Accept PRO Reject Key V25E Load desired data (per following tables) Key V93E	2,140	Option code: (initially 00000) 00000 - No initialization 00001 - RNDZ W-matrix reinitialization. Bypasses reinitialization, if R3 = 00000. R3 must contain 00001 to allow initialization. To initialize at new values. Initialization occurs next time a measurement is made. V93E required to enable r/v W-matrix initialization. N99 values to be loaded to obtain desired POS ERR and VEL ERR elements with corresponding octal values for erasable.
W-MATRIX TABLE (V67)			
WRENDPOS	2000-P20	WRENDVEL	2001-P20
N99 R1	1000 ft	OCT	N99 R2
			fps
10000	10	137	10
08000	8	114	8
06000	6	71	6
04000	4	46	4
02000	2	23	2
01000	1	11	1
00800	.8	7	.8
00600	.6	5	.6
00400	.4	3	.4
00300	.2	2	.2
00100	.1	1	.1
			OCT
			762
			620
			453
			307
			144
			61
			50
			34
			24
			10
			5

(V67) START W-MATRIX RSS ERROR DISPLAY

APOLLO-SOYUZ TEST PROJECT (ASTP)
OPERATIONS HANDBOOK

STA/T STEP	PROCEDURE	PANEL	REMARKS
8.3.8	(V74) Initialize Erasable Dump Via <u>Downlink</u>		Dumps all eight banks of erasable memory via downlink.
CP 1	CMC - on (req), 8.1.3 Key V74E (V74 will deliver two complete dumps)	2,140	Displays sum of each bank for comparison.
8.3.9	(V91) Display Banksum		Procedure must be performed in P00.
1	Key V37E 00E		If another extended verb active.
2	Key V91E		Sum of bits of chosen bank. Number of bank being read. Factor required to make $ R1 = R2 $.
3	FL V05 N01 Banksum Bank No. Bugger word Accept V34E (halt summing) Reject PRO, recycle 3 (next bank)		Expected bank and banksum acceptable ($ R1 = R2 $). 43 (octal) banks (i.e., R2 = 00043 in V05 N01 display). Banks are numbered 00 to 43 (octal) corresponding to 00 to 35 (decimal) = 36 decimal banks.

8.3.8

(V74) INITIALIZE ERASABLE DUMP VIA DOWNLINK

NORMAL BACKUP

APOLLO-SOYUZ TEST PROJECT (ASTP)
OPERATIONS HANDBOOK

STA/T STEP	PROCEDURE	PANEL	REMARKS
8.4	SCS GENERAL		
8.4.1	<u>SCS Power Down</u>		Describes safe power-down configuration.
1	Provide Safe Sys Configuration	1	
AC	EMS - STBY/OFF		
	EMS FUNC - OFF		
	EMS MODE - STBY	8	
	AUTO RCS (16) - OFF	1	Normal position selected to prevent inadvertent SPS firing.
	BMAG MODE (3) - RATE 2		
	SPS THRUST - NORM		
2	Remove SCS Pwr	7	
	TVC SERVO PWR (both) - OFF		
	FDAI/GPI PWR - OFF		
	LOGIC 2/3 PWR - OFF		
	ELEC PWR - OFF		
	SIG CONDR/DR BIAS PWR (both) - OFF		
	BMAG PWR (both) - WARMUP	1	
	RHC PWR NORM (both) - OFF		
	XXXXXXXXXXXXXXXXXXXXX		
	X		
	For tot pwr down		
	BMAG 1 PWR - OFF	7	6.1.2, note 7.
	XXXXXXXXXXXXXXXXXXXXX		
	X		
3	Pwr Down ORDEAL	13	
	FDAI sw (both) - INREL		
	EARTH/LUNAR - PWR OFF		
	LTG - OFF		

SCS POWER DOWN

APOLLO-SOYUZ TEST PROJECT (ASTP)
OPERATIONS HANDBOOK

STA/T STEP	PROCEDURE	PANEL	REMARKS
DP	4 Pwr Down COAS COAS PWR - OFF	15	
AC CP	5 Miscellaneous THC - neut, LOCKED RHC (both) - LOCKED		
AC	6 Remove Logic Sw Pwr FDAI SCALE - 5/1 FDAI SEL - 1 or 2 ATT SET - GDC MAN INT (3) - RATE CMD LIM CYCLE - on (up) DBD/RATE - MAX/LO ATT DBD - MAX RATE - LO EMS ROLL - OFF .05 G sw - OFF (verify) TVC GMBL DR (2) - 1	1	Optional step to place panel 1 switches on logic buses in their OFF position. Relationship between switch positions and logic buses described in 6.1.1.1, figure 6-3. ATT SET switch should be left at GDC when not in use. Also refer to 6.1.1.1, note 6. Remains OFF throughout mission except entry. Refer to 6.1.1.1, note 5. Off position powered by LOGIC 2/3 PWR - on (up). Used to power up display and control electronics of SCS.
	8.4.2 SCS Power Up		
	1 Provide Safe Sys Configuration AUTO RCS (16) - OFF BMAG MODE (3) - RATE 2	8 1	Cages BMAGs and prevents attitude error signal, if any, from causing jet firings when RCS enabled.

8.4.2

SCS POWER UP

NORMAL BACKUP

APOLLO-SOYUZ TEST PROJECT (ASTP)
OPERATIONS HANDBOOK

STA/T STEP	PROCEDURE	PANEL	REMARKS
AC	2 Set Pwr Switches LOGIC 2/3 PWR - on (up) ELEC PWR - GDC/ECA SIG CONDR/DR BIAS PWR (both) - AC1 or AC2	7	Configures G&C for future command/control functions. Provides power for control and GDC electronics. Switch 1 also provides SCS signal conditioner power for the following TLM functions: rate and attitude error, SCS auto TVC, MTVC, gimbal position transducer and RHC proportional rate commands. Switch 2 provides SCS signal conditioner power for TVC pitch and yaw differential clutch current TLM. For increased reliability, switches should not be set on same bus. Also refer to 6.1.2, note 5.
CP	BMAG TEMP lt (2) - out	2	If FDAIs are powered when BMAGs come up to speed, rate needles will oscillate full scale.
AC	FDAI/GPI PWR - OFF BMAG PWR (both) - ON FDAI/GPI PWR - BOTH RHC PWR NORM (both) - AC/DC	7	Provides rate and attitude source for control and display functions. Provides power for display electronics. Provides power to RHC for manual control functions if needed.
	8.4.3 <u>Drift Rate Adjust</u>		Permits periodic adjustment of finite drift rates of <1 deg/sec. It is intended for use during long periods of drift such as in thermal control where high power consumption undesirable.
	1 Set Up Pwr Sw LOGIC 2/3 PWR - on (up) ELEC PWR - ECA	7	Powers panel 1 controls for command/control functions. Powers control electronics.

DRIFT RATE ADJUST

APOLLO-SOYUZ TEST PROJECT (ASTP)
OPERATIONS HANDBOOK

STA/T STEP	PROCEDURE	PANEL	REMARKS
CP AC	<p>BMAG TEMP 1t (2) - out FDAI/GPI PWR - OFF</p> <p>BMAG 2 PWR - ON</p> <p>FDAI/GPI PWR - 1</p> <p>SIG CONDR/DR BIAS PWR (both) - AC1 or AC2</p> <p>RHC PWR NORM (both) - AC/DC</p> <p>2 Establish Rate Disp for Ball 1, 7.2.1 FDAI SEL - 1 BMAG MODE - RATE 2 .05 G sw - OFF (verify)</p> <p>3 Establish SCS Min Imp, 7.1.2 MAN ATT (3) - MIN IMP SC CONT - SCS AUTO RCS - MNA or MNB</p> <p>4 Adj Veh Rates RHC - ARMED Adj rates using FDAI 1 RHC - LOCKED</p>	<p>2 7</p> <p>1</p> <p>8</p>	<p>If FDAIs are powered when BMAGs come up to speed, rate needles will oscillate full scale.</p> <p>Provides rate source for control and display functions.</p> <p>Provides power for display electronics.</p> <p>6.1.2, note 5.</p> <p>Single jet control in each axis preferred to allow fuel conservation.</p> <p>FDAI SCALE - 5/1 recommended since expected rates will be <1 deg/sec.</p>

DRIFT RATE ADJUST

8.4.3

NORMAL BACKUP

APOLLO-SOYUZ TEST PROJECT (ASTP)
OPERATIONS HANDBOOK

STA/T STEP	PROCEDURE	PANEL	REMARKS
8.4.4	<u>Minimum Power SCS Attitude Hcld</u> (Three or Two Axes)		Provides attitude hold in two or three axes, as desired, for prolonged periods using low power consumption.
AC	1 Set Pwr Sw	7	
	LOGIC 2/3 PWR - on (up)		
	ELEC PWR - ECA		If total attitude display desired, select GDC/ECA.
CP	BMAG TEMP lt (2) - out	7	
AC	FDAL/GPI PWR - OFF		If FDAIs powered when BMAGs come up to speed, rate needles will oscillate full scale.
	SIG CONDR/DR BIAS PWR (both) - AC1 or AC2		6.1.2, note 5.
	BMAG PWR (both) - ON		Provides power for display electronics.
	FDAL/GPI PWR - 1		
2	Establish SCS Att Hold/Rate Cmd, 7.1.4 MAN ATT (3 or 2) - RATE CMD	1	Selection by axis using these switches will determine axes in which attitude hold is enabled.
	LIM CYCLE - on (up)		
	DBD/RATE - MAX/LO		
	ATT DBD - MAX		
	RATE - LO		
	SC CONT - SCS		
	BMAG MODE (3) - RATE 2		
	AUTO RCS - MNA or MNB		
	BMAG MODE (3 or 2) - ATT 1/RATE 2		Single jet control in each axis preferred to allow fuel conservation.
3	Sel Disp, 7.2.1 & 2 FDAL - 1/GDC FDAL SEL - 1 FDAL SOURCE - GDC .05 G sw - OFF (verify)	1	

MINIMUM POWER SCS ATTITUDE HOLD

APOLLO-SOYUZ TEST PROJECT (ASTP)
OPERATIONS HANDBOOK

STA/T STEP	PROCEDURE	PANEL	REMARKS
AC 4	<p>Monitor FDAI 1 att err during limit cycling</p> <p>8.4.5 <u>SCS Attitude Maneuver</u></p> <p>1 The following are req ISS - on & orient known (for step 3a), 8.1.3 & sec 13 SCS - on, 8.4.2 CMC ATT - IMU (verify) .05 G sw - OFF (verify)</p> <p>2 Obtain mnvr data from STDN</p> <p>a. Fnl mnvr angles R <u> </u>°, P <u> </u>°, Y <u> </u>°</p> <p>or b. External ref cues</p> <p>3 Maneuver</p> <p>a. To specified mnvr angles If ISS avail Perform GDC align to IMU gmb1 angles, 8.4.6 If ISS not avail Perform alternate SC Inertial Att Determination, 13.2.1</p>	1	<p>Provides options for performing SCS attitude maneuver during normal orbital operations or to satisfy specific mission requirements. Permits easy correlation to G&C Reference Modes, sec 7, and other G&C General Procedures, sec 8.</p> <p>Select FDAI display as required. Also refer to 6.1.2, note 6.</p>

8.4.5 SCS ATTITUDE MANEUVER

NORMAL BACKUP

APOLLO-SOYUZ TEST PROJECT (ASTP)
OPERATIONS HANDBOOK

STA/T STEP	PROCEDURE	PANEL	REMARKS
AC	<p>Set ATT SET tw - to desired values (step 2) Sel att cont mode, 7.1</p> <p>RHC - mnvr</p> <p>or b. To external ref Sel att cont mode, 7.1 RHC - mnvr</p> <p>8.4.6 <u>GDC Alignment to IMU Gimbal Angles</u></p>	1	<p>Mode should be compatible with magnitude of maneuver - e.g., rate command, acceleration command or minimum impulse, and desired rates.</p> <p>Use total attitude and/or attitude error displays as required to obtain final gimbal angles.</p> <p>Null rates at desired orientation.</p> <p>Provides two methods for aligning GDC to IMU.</p>
	<p>1 The following are req CMC - (on for step 3b), 8.1.3 ISS - on & orient known, 8.1.3 & sec 13 SCS - on, 8.4.2 CMC ATT - IMU (verify) .05 G sw - OFF (verify) FDAI 1 sw - INRTL (desired)</p>	13	<p>Provides easy comparison between FDAI and ATT SET values.</p>
	<p>2 Establish Att Cont, 7.1 Damp veh rates</p>		<p>Selected to prevent drift error during alignment process.</p>
	<p>3 Perform Att Err Disp - ISS Att Set Source, 7.2.4</p> <p>a. FDAI - 1/ATT SET/IMU FDAI SEL - 1</p>	1	<p>6.1.1, note 6.</p>

GDC ALIGNMENT TO IMU GIMBAL ANGLES

APOLLO-SOYUZ TEST PROJECT (ASTP)
OPERATIONS HANDBOOK

STA/T STEP	PROCEDURE	PANEL	REMARKS
AC	<p>FDAI SOURCE - ATT SET ATT SET - IMU ATT SET tw - null FDAI 1 errors</p>	1	Verify that ATT SET tw and FDAI 1 indicate same total attitude because false nulling of error needles could occur 180° from desired attitude.
CP AC	<p>b. V16 N20E ATT SET tw - adj to IMU gmb1 angles on DSKY</p> <p>or c. ATT SET tw - adj to IMU gmb1 angles as ind on FDAI</p>	2,140 1	
	<p>4 Align GDC, 7.3 ATT SET - GDC GDC ALIGN pb - push, hold FDAI SEL - 1/2</p>		Verify both FDAIs indicate same total attitude.
	<p><u>8.4.7 Attitude Reference System Comparison</u></p> <p>1 The following are req CMC - on, 8.1.3 ISS - on and orient known, 8.1.3 & sec 13 SCS - on, 8.4.2 CMC ATT - IMU (verify) .05 G sw - OFF (verify)</p>		
SPT	<p>2 Key V37E 00E</p> <p>3 Establish Att Cont, 7.1 Damp veh rates</p>	2,140	

ATTITUDE REFERENCE SYSTEM COMPARISON

8.4.7

NORMAL BACKUP

APOLLO-SOYUZ TEST PROJECT (ASTP)
OPERATIONS HANDBOOK

STA/T STEP	PROCEDURE	PANEL	REMARKS
CP	4 Key V06 N20E (ICDU angles) R, P, Y XXX.XX DEG	2,140	Required to allow rough ATT SET adjustment to IMU gimbal angles prior to nulling operation. Monitor V16 may be used in lieu of display V06.
AC	5 Att ref comparison Select Att Err Disp, Att Set Source, 7.2.4 FDAI - 1/ATT SET/IMU FDAI SEL - 1 FDAI SOURCE - ATT SET ATT SET - IMU ATT SET tw (3) - set approx to DSKY values, null FDAI 1 att errors ENTR (when nulled)	1 2,140	6.1.1, note 6. ENTR updates display. If monitor V16 used in step 4, key VERB to freeze display. If ATT SET/GDC comparison made, error needle bias, if any, determined and may be subtracted (postflight) from GDC drift determined in ATT SET/GDC comparison.
AC	or ATT SET/GDC comparison ATT SET - GDC		
CP	ATT SET tw (3) - null FDAI 1 att errors ENTR (when nulled) Record DSKY values R <u> </u> °, P <u> </u> °, Y <u> </u> ° Record ATT SET values R <u> </u> °, P <u> </u> °, Y <u> </u> °	2,140 1	ENTR updates display. If monitor V16 used in step 4, key VERB to freeze display.

ATTITUDE REFERENCE SYSTEM COMPARISON

APOLLO-SOYUZ TEST PROJECT (ASTP)
OPERATIONS HANDBOOK

STA/T STEP	PROCEDURE	PANEL	REMARKS
8.4.8	<u>ORDEAL Initialization</u>		
1	<p>The following are req CMC - on (for steps 4a & 7a), 8.1.3 ISS - on & aligned, nom option (for step 7a), 8.1.3 & sec 13 SCS - on, 8.4.2 CMC ATT - IMU (verify) .05 G sw - OFF (verify)</p>	1	<p>Aligns one or both FDAIs to local vertical coordinates.</p> <p>IMU and/or SCS attitude reference system must be aligned with +Y axis of reference along ($\underline{V} \times \underline{R}$), where V is velocity vector and R is position vector from center of earth.</p>
2	Sel Tot Att Disp, 7.2.5		
3	Set ORDEAL cont, 7.2.6 FDAI 2 or 1 sw - ORB RATE EARTH/LUNAR - EARTH MODE - HOLD/FAST	13	Either or both FDAIs may be driven by ORDEAL.
4	Obtain alt setting		
a.	(R30) orb param disp routine Key V82E Record Ha and Hp Calculate ave	2,140	
or b.	(P21) ground track determination prog Key V37E 2LE Record alt for 10-min intervals of present orb Calculate ave		
AC			
CP			
8.4.8		ORDEAL INITIALIZATION	

NORMAL BACKUP

APOLLO-SOYUZ TEST PROJECT (ASTP)
OPERATIONS HANDBOOK

STA/T STEP	PROCEDURE	PANEL	REMARKS
or c. STDN	If CMC in STBY, obtain alt setting from STDN		
AC	5 ALT SET - adj to proper alt	13	
6	Sel att cont mode, 7.1, & mnvr to place +Xsc in orb plane (0° yaw)		
7	Obtain θ - pitch angle to lcl horiz		
a.	(R31) rndz param disp routine Key V83E	2,140	
AC	or b. STDN If CMC in STBY, obtain θ from STDN based on +Xsc pointed at horiz	13	
8	Slew FDAI to θ		
9	MODE - OPR/SLOW Slew/adj FDAI precisely		
10	Repeat 7 thru 9 as req		

ORDEAL INITIALIZATION

APOLLO-SOYUZ TEST PROJECT (ASTP)
OPERATIONS HANDBOOK

STA/T STEP	PROCEDURE	PANEL	REMARKS
8.4.9	SCS Passive Thermal Control Using <u>Wobble Mode</u>		For G&N Passive Thermal Control Procedure, refer to 8.1.13.
AC	1 Set up pwr sw LOGIC 2/3 PWR - on (up) ELEC PWR - ECA	7	If total attitude display desired, select GDC/ECA.
CP	BMAG TEMP lt (2) - out	2	
AC	FDAL/GPI PWR - OFF BMAG PWR (both) - ON FDAL/GPI PWR - 1	7	If FDALs powered when BMAGs come up to speed, rate needles will oscillate full scale.
	SIG CONDR/DR BIAS PWR (both) - AC1 or AC2 RHC PWR NORM (both) - AC/DC	1	6.1.2, note 5.
2	Establish SCS att hold/rate cmd MAN ATT (3) - RATE CMD LIM CYCLE - on (up) DBD/RATE - MIN/LO ATT DBD - MIN RATE - LO SC CONT - SCS BMAG MODE (3) - RATE 2 AUTO RCS A/C ROLL or B/D ROLL (4) - MNA or MNB AUTO RCS PITCH & YAW - set for single jet oper BMAG MODE (3) - ATT 1/RATE 2		This switching assumes RCS not enabled or attitude error needles are nulled before this switching performed. Only one pair of roll quads should be enabled. Single jet control in PITCH and YAW provides reduced RCS authority for attainment of minimum rates.

8.4.9 SCS PASSIVE THERMAL CONTROL USING WOBBLE MODES

NORMAL BACKUP

APOLLO-SOYUZ TEST PROJECT (ASTP)
OPERATIONS HANDBOOK

STA/T STEP	PROCEDURE	PANEL	REMARKS
CDR	<p>3 Select Disp FDAI - 1/GDC FDAI SEL - 1 FDAI SOURCE - GDC .05 G sw - OFF (verify)</p>	1	<p>Maneuver should place desired wobble axis in CSM -Z+Y quadrant, _____° from X axis.</p>
	<p>4 Mnvrc SC to desired att</p>		<p>Allow CSM to deadband to these rates. Rate may be obtained manually if minimum impulse control used.</p>
	<p>5 Achieve pitch up & yaw right rates of 0.01-0.02°/sec</p>		
	<p>6 MAN ATT ROLL - ACCEL CMD LIM CYCLE - OFF DBD/RATE - MAX/HI ATT DBD - MAX RATE - HI BMAG MODE (3) - RATE 2 AUTO RCS ROLL (8) - MNA or MNB Init _____°/sec roll rate AUTO RCS (16) - OFF</p>	8	<p>Full roll authority can be used to establish this rate with one RHC action.</p>
	<p>8.4.10 SCS Passive Thermal Control Using <u>BAR-B-Q Minimum Power Mode</u></p>		<p>For G&N Passive Thermal Control Procedure, refer to 8.1.13</p>
	<p>1 Set up pwr sw LOGIC 2/3 PWR - on (up) SCS ELEC PWR - ECA BMAG TEMP lt (2) - out</p>	7 2	<p>If total attitude display desired, select GDC/ECA.</p>
SPT			

SCS PASSIVE THERMAL CONTROL USING BAR-B-Q MINIMUM POWER MODE

APOLLO-SOYUZ TEST PROJECT (ASTP)
OPERATIONS HANDBOOK

STA/T STEP	PROCEDURE	PANEL	REMARKS																				
AC	<p>FDAI/GPI PWR - OFF</p> <p>BMAG PWR (both) - ON</p> <p>FDAI/GPI PWR - 1</p> <p>SIG CONDR/DR BIAS PWR (both) - AC1 or AC2</p> <p>RHC PWR NORM (both) - AC/DC</p> <p>2 Sel Disp</p> <p>FDAI - 1/GDC</p> <p>FDAI SEL - 1</p> <p>FDAI SOURCE - GDC</p> <p>.05 G sw - OFF (verify)</p> <p>3 Mnavr SC to desired att</p> <p>4 Establish 2 axis SCS att hold/rate cmd</p> <p>MAN ATT P&Y (2) - RATE CMD</p> <p>MAN ATT ROLL - ACCEL CMD</p> <p>LIM CYCLE - on (up) or MIN IMP</p> <p>DBD/RATE - MAX/HI</p> <p>ATT DBD - MAX</p> <p>RATE - HI</p> <p>SC CONT - SCS</p> <p>AUTO RCS PITCH & YAW - set for single jet oper</p>	7	<p>If FDAIs powered when BMAGs come up to speed, rate needles will oscillate full scale.</p> <p>6.1.2, note 5.</p>																				
		8	<p>Engine combinations available for single jet control are:</p> <table border="1" style="margin-left: auto; margin-right: auto;"> <thead> <tr> <th colspan="4">SINGLE JET CONTROL</th> </tr> </thead> <tbody> <tr> <td>PITCH</td> <td>A3-A4</td> <td>C3-C4</td> <td>A3-C4</td> </tr> <tr> <td>YAW</td> <td>B3-B4</td> <td>D3-D4</td> <td>B3-D4</td> </tr> <tr> <td></td> <td></td> <td></td> <td>C3-A4</td> </tr> <tr> <td></td> <td></td> <td></td> <td>D3-B4</td> </tr> </tbody> </table>	SINGLE JET CONTROL				PITCH	A3-A4	C3-C4	A3-C4	YAW	B3-B4	D3-D4	B3-D4				C3-A4				D3-B4
SINGLE JET CONTROL																							
PITCH	A3-A4	C3-C4	A3-C4																				
YAW	B3-B4	D3-D4	B3-D4																				
			C3-A4																				
			D3-B4																				

8.4.10

SCS PASSIVE THERMAL CONTROL USING BAR-B-Q MINIMUM POWER MODE

NORMAL BACKUP

APOLLO-SOYUZ TEST PROJECT (ASTP)
OPERATIONS HANDBOOK

STA/T STEP	PROCEDURE	PANEL	REMARKS
AC	AUTO RCS A/C ROLL or B/D ROLL (4) - MNA or MNB EMAG MODE (3) - ATT 1/RATE 2	8	
5	Init 0.1°/sec roll rate	1	
6	Mon FDAI 1 att err during limit cycling		

SCS PASSIVE THERMAL CONTROL USING BAR-B-Q MINIMUM POWER MODE

APOLLO-SOYUZ TEST PROJECT (ASTP)
OPERATIONS HANDBOOK

STA/T STEP	PROCEDURE	PANEL	REMARKS
9.0 RENDEZVOUS	<p>Rendezvous is accomplished by systematic performance of various navigation, alignment, targeting and thrusting programs. Manual-sequenced rendezvous is performed by manual selection of each program as it is required in the rendezvous sequence. For the MINKEY sequence, the MINKEY program automatically selects and sequences the various programs. Refer to 9.1 for manual-sequenced rendezvous and 4.9.2 for the MINKEY sequence.</p>		
9.1	MANUAL RENDEZVOUS SEQUENCE		
	<p>CMC - on (req), 8.1.3 ISS - on & orient known (req), 8.1.3 & sec 13 SCS - on (req), 8.4.2 Opt pwr up (req), 8.1.4</p>		
	<p>RCS DAP - load & activate (req), 8.2.1 Set up for VHF rng, 4.5.3</p>		Required for target acquisition and SXT tracking during rendezvous phase.
	<p>1 Verify/confirm with STDN, oper status of Soyuz &/or CSM sys</p>		
	<p>2 Select desired att cont, 7.1</p>		
	<p>3 Select desired disp, 7.2</p>		
	<p>4 Perform rndz nav, 10.2</p>		
	<p>5 Perform targeting, 11.2</p>		
	<p>6 Perform thrusting, sec 12</p>		

9.1

MANUAL RENDEZVOUS SEQUENCE

NORMAL BACKUP

9.2 MINKEY RENDEZVOUS SEQUENCE

The MINKEY controller routine (R07) monitors and executes in proper sequence, all programs required for effecting rendezvous. P20, however, operates in the background and, unlike P31 through P38, is not displayed in the PROG Lt, except for the P20 call during the NPC (P38) sequence.

MINKEY sequence is initiated by selecting the appropriate targeting program for a given point in the sequence. The sequence begins at any one of seven entry points which is determined by the targeting program selected. The seven entry points are defined as follows:

P31 (NC1)
P32 (NC2)
P33 (NCC)
P34 (NSR)
P35 (TP1)
P36 (TPM)
P37 (TPF)

To enter the MINKEY sequence before NC1 (Normal Corrective Mvvr #1), P31 is selected; to enter before NC2, P32 is selected, etc. The MINKEY controller will, from entry point selected, automatically sequence the required programs. As with other CMC programs, the operator must accept or reject data, or provide desired data to the CMC to have the programs sequence properly.

9.2.1 MINKEY Operating Notes

The MINKEY process minimizes a number of calculations, loading of data, and certain operator decision requirements. Some of these features and other data pertinent to MINKEY are defined in the following MINKEY operating notes.

1. An erasable quantity designating desired attitude for performing rendezvous is preloaded. According to this value, the CMC computes and executes the appropriate attitude maneuvers.

MINKEY RENDEZVOUS SEQUENCE

APOLLO-SOYUZ TEST PROJECT (ASTP)
OPERATIONS HANDBOOK

2. Calculations for out-of-plane corrections are automatically performed, displayed, and scheduled for the appropriate maneuver.
3. The CMC reinitializes the W-matrix according to predetermined data requiring no operator consideration.
4. VHF range data are automatically collected and processed continuously in R22 when enabled by V87E (terminated by V88E), and in R22 (via R27) when enabled by V76E (terminated by V77E). When called by R22, VHF measured range is extended beyond 321.67 NM if indicated by the range computed in R61 using on-board state vector estimates.
5. SXT data (marks) can be taken at any flashing display when P20 is running (extended verb not required).
6. P52 provides option for GYRO torquing ($\pm 45^\circ$ depending on state of TCOMPFLG) prior to NPC maneuver and if torqued, returned to original alignment after burn. Provides more suitable platform orientation for the thrusting maneuver.
7. The NPC sequence (P38) can only be entered via V37E 38E. It is not automatically called, in line, by the MINKEY controller.
8. Providing REFSMFLG set, keying in any one of the targeting programs, P31 through P38, causes an immediate display of FL V50 N25, R1 = 00017 (request MINKEY). A PRO response initiates automatic sequencing. EWTR inhibits automatic and allows manual sequencing.
9. For both PRO and EWTR to FL V50 N25 (R1 = 00017), R61/R60 is selected to execute maneuver to tracking attitude via P20. By holding at any flashing display, optics (SXT) marks or COAS marks (V54E), can be taken anytime P20 is running (after maneuver to track attitude), or VHF ranging marks may be allowed to accumulate provided VHF ranging has been enabled (refer to note 4).
10. For P20 (options 0, 1, 4, 5), as applied to R61/R60 (maneuver to track attitude), the 10° criterion is pointing error measured as angle between the LOS and center of DAP deadband.

9.2.1

MINKEY RENDEZVOUS SEQUENCE

NORMAL BACKUP

APOLLO-SOYUZ TEST PROJECT (ASTP)
OPERATIONS HANDBOOK

9.2.2 MINKEY Rendezvous Sequence (Flow)

Following is a simplified flow diagram of the MINKEY rendezvous sequence. The diagram summarizes the sequence of events as they would occur from any one of the entry points into the MINKEY sequence (i.e., selection of P31, P32, etc.). Each program, as it is called by the MINKEY controller, is completed in the usual manner, even though, as previously stated, certain additional functions are performed by the CMC, thus minimizing the need for operator actions otherwise needed for program completion.

MINKEY RENDEZVOUS SEQUENCE

APOLLO-SOYUZ TEST PROJECT (ASTP)
OPERATIONS HANDBOOK

NORMAL BACKUP

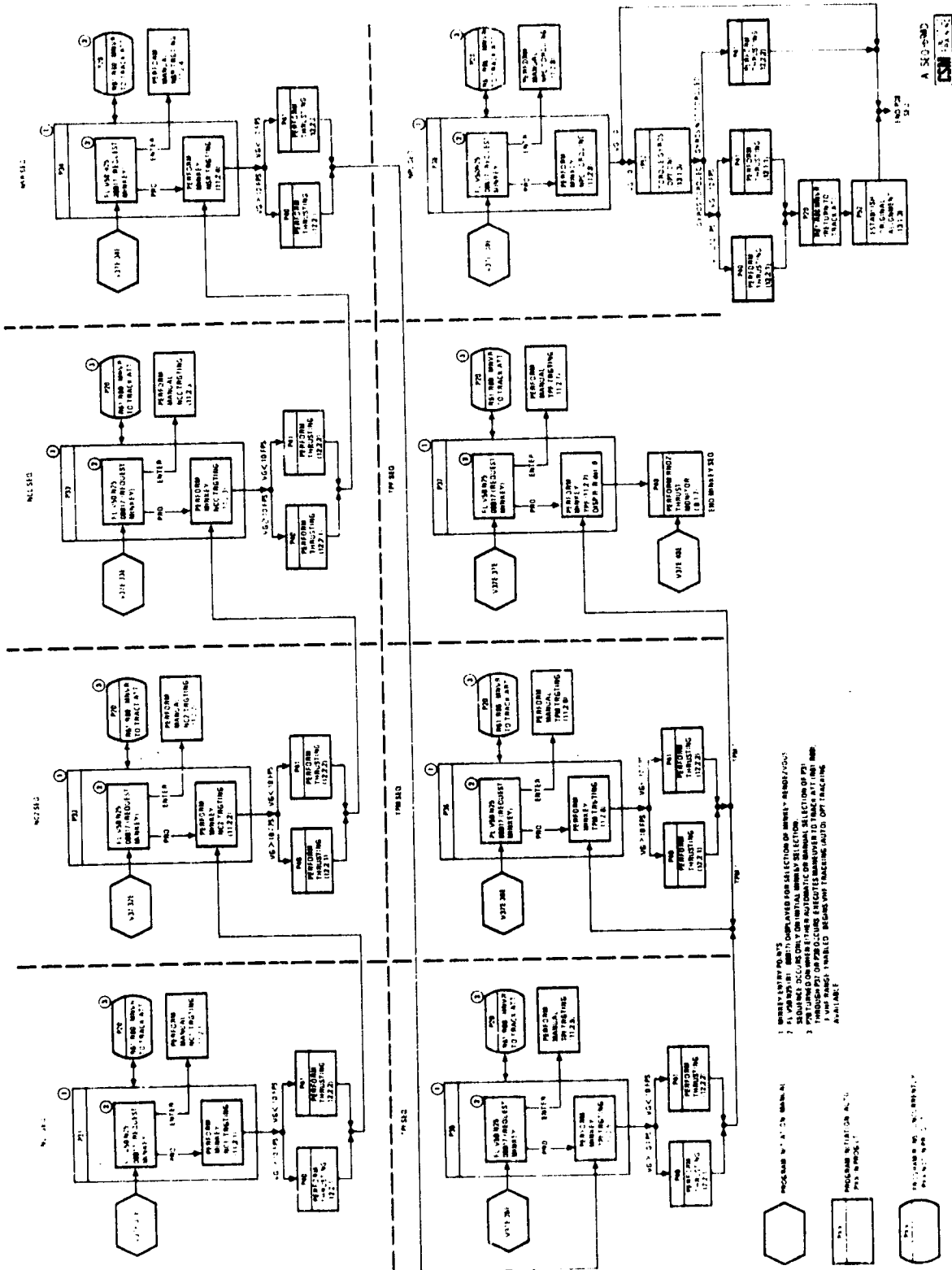

MINKEY RENDEZVOUS SEQUENCE

9.22

AFOLLO-SOYUZ TEST PROJECT (ASTP)
OPERATIONS HANDBOOK

STA/T STEP	PROCEDURE	PANEL	REMARKS
10.0	NAVIGATION		For general G&C operating data, refer to operating notes, 6.1.
10.1	ORBITAL NAVIGATION		Provides crew ground track data for either CSM or Soyuz, based on time loaded in 3.
10.1.1	<u>(P21) Ground Track Determination</u>		
	CMC - on (req), 8.1.3		CMC initializes R2 to 00001.
CP	1 Key V37E 21E	2,140	
2	FL V04 M06 Option code 00002 CMC assumed option 00001 (00001 = CSM, 00002 = Soyuz)		
3	FL V06 N34 Accept PRO Reject V22E (load desired option)		Initial display will contain zeros (present time). If not changed by astronaut, P21 calculations will be based on present time.
	GET lat long	00XX. HRS 00XX. MIN 0XX.XX SEC	GET at desired position of selected vehicle.
	Accept PRO Reject V25E (load desired T-lat long)		State vector integrated forward to desired time.

10.1.1

(P21) GROUND TRACK DETERMINATION

NORMAL BACKUP

APOLLO-SOYUZ TEST PROJECT (ASTP)
OPERATIONS HANDBOOK

STA/T STEP	PROCEDURE	PANEL	REMARKS
CP 4	FL V06 N43 Lat (+N) Long (+E) Alt If desired Key N73E Alt/10 VI Gamma	2,140 XXX.XX DEG XXX.XX DEG XXXX.X NM XXXXX. NM XXXXX. FPS XXX.XX DEG	Selected vehicle latitude at T-lat long. Selected vehicle longitude at T-lat long. Selected vehicle altitude above launch pad radius at T-lat long.
5	PRO (term P21) FL V37 Key XXE		For V32E, program keeps previous state vector for use in starting next iteration without, however, ensuring that subsequent integrations are precision. If times reasonably close, V32E should be used; if far apart, would be quicker to reselect P21. ROO.

(P21) GROUND TRACK DETERMINATION

APOLLO-SOYUZ TEST PROJECT (ASTP)
OPERATIONS HANDBOOK

STA/T STEP	PROCEDURE	PANEL	REMARKS
	10.1.2 (P29) <u>Time of Longitude</u>		Provides time of (CSM or Soyuz) first crossing of a specified longitude after a specified time.
CP	CMC - on (req), 8.1.3	2,140	
1	Key V37E 29E		CMC initializes R2 to 00001.
2	FL V04 N06 Option code 00002 CMC assumed option 00001 (00001 = CSM, 00002 = Soyuz)		Initial display will contain zeros (present time). If not changed by astronaut, P29 calculations will be based on present time.
3	FL V06 N34 GET base time		Base time from which next crossing of desired longitude is computed.
4	FL V06 N43 R2 Long (desired)		State vector integrated forward to desired base time.

(P29) TIME OF LONGITUDE

10.1.2

NORMAL BACKUP

APOLLO-SOYUZ TEST PROJECT (ASTP)
OPERATIONS HANDBOOK

STA/T STEP	PROCEDURE	PANEL	REMARKS
CP	Accept PRO Reject V22E (load long)	2,140	CMC computes time of next crossing of desired longitude after base time.
5	FL V06 N34 GET long O0XX. HRS 000X. MIN OXX.XX SEC		Time of longitude crossing.
6	Accept PRO Reject V32E, return to 4 FL V06 N43 Lat (+N) Long (+E) Alt XXX.XX DEG XXX.XX DEG XXXX.X MM		To re-specify longitude using original base time. Latitude, longitude, altitude at crossing.
7	Accept PRO (Term P29) Reject V32E, return to 2 FL V37 Key XXE		To re-specify input data.

(P29) TIME OF LONGITUDE

APOLLO-SOYUZ TEST PROJECT (ASTP)
OPERATIONS HANDBOOK

STA/T STEP	PROCEDURE	PANEL	REMARKS
10.1.1.3	<u>(V82) Orbit Parameter Display (R30)</u>		
CMC - on (req), 8.1.1.3			
CP 1	Key V82E If ave G routine on, go to 4	2,140	Provides crew with CMC computed orbital parameters. Time from perigee (TF perigee) available via N32 if Hp > 49.4 NM (300,000 feet). If P00 or P11 running, AR (miss distance) available via N50.
2	FL V04 N12 Option code 00002 CMC assumed option 0000X (1 = CSM 2 = Soyuz)		
3	FL V06 N16 GET event Accept PRO Reject V22E (load desired option)	00XX. HRS 00XX. MIN 0XX.XX SEC	Time for state vector integration. TFF (N50) and time from perigee (N32) continue to be measured from present time rather than N16 input time. CMC sets time option initially to zero, meaning present time.
CP	Accept PRO Reject Key V25E Load desired time		

10.1.1.3 (V82) ORBIT PARAMETER DISPLAY (R30)

NORMAL BACKUP

APOLLO-SOYUZ TEST PROJECT (ASTP)
OPERATIONS HANDBOOK

STA/T STEP	PROCEDURE	PANEL	REMARKS
CP 4	FL V16 N44	2,140	If average G on, display updates every 2 seconds.
	Ha Hp	XXXX.X NM XXXX.X NM	Above launch pad radius. Calculations are subject to limitations of two-body approximation and yield reasonable results if vehicle close to earth.
	TFF	XXBXX MIN-SEC	Time of free fall to 49.4 NM (300,000 feet). TFF reads -59B59 if Hp >49.4 NM; under these conditions, time from perigee available by keying N32. If average G off and Hp <49.4 NM, TFF counts down. For N32, if average G off and Hp >49.4 NM, time from perigee counts down.
	Accept PRO Reject V32E Recycle to 3		Recalculates orbital parameters. (Valid only if average G off.)

(V82) ORBIT PARAMETER DISPLAY (R30)

APOLLO-SOYUZ TEST PROJECT (ASTP)
OPERATIONS HANDBOOK

STA/T STEP	PROCEDURE	PANEL	REMARKS
10.2	RENDEZVOUS NAVIGATION		
10.2.1	(P20) <u>Universal Tracking & Rendezvous Navigation</u>		<p>Purpose:</p> <ul style="list-style-type: none"> • Rendezvous - Performs normal rendezvous navigation, attitude control, and optics pointing. • Rotation - To produce a rotation about a specified SC body vector. • Universal tracking - To point (and maintain) a specified SC vector at a specified celestial body. <p>Crew may exercise control of P20 functions via response to M06, M78, M79 and through use of the following extended verbs.</p> <ul style="list-style-type: none"> V76E - Enables R27 in R22. V77E - Disables R27 in R22. V80E - Selects Soyuz state vector update. V81E - Selects CSM state vector update. V87E - Allow R22 to accept VHF range data. V88E - Inhibit acceptance of VHF range data. <p>Program can be selected manually (V37E 20E), or automatically by MINKEY controller. Refer to 9.2 for additional data on MINKEY rendezvous sequence.</p> <p>Provides total attitude and rate monitoring. Not required for VHF update.</p>

CMC - on (req), 8.1.3
ISS - on & orient known (req),
8.1.3 & sec 13
SCS - on (desired), 8.4.2
Opt pwr up (req), 8.1.4

10.2.1

(P20) UNIVERSAL TRACKING & RENDEZVOUS NAVIGATION

NORMAL BACKUP

APOLLO-SOYUZ TEST PROJECT (ASTP)
OPERATIONS HANDBOOK

STA/T STEP	PROCEDURE	PANEL	REMARKS																																																																																															
AC	VHF AM ranging mode sel (req), 5.6.3 CMC ATT - IMU (verify) LOGIC 2/3 PWR - on (up) (if no SCS)	1 7	Not required for optical update. Required for control and display functions.																																																																																															
			<table border="1"> <thead> <tr> <th rowspan="2">Programs Allowing P20 in Background</th> <th colspan="5">P20 Option</th> </tr> <tr> <th>0</th> <th>1</th> <th>2</th> <th>4</th> <th>5</th> </tr> </thead> <tbody> <tr> <td>21**</td> <td>X</td> <td>X</td> <td>X</td> <td>X</td> <td>X X X X X</td> </tr> <tr> <td>27*</td> <td>X</td> <td>X</td> <td>X</td> <td>X</td> <td>X X X X X</td> </tr> <tr> <td>29**</td> <td>X</td> <td>X</td> <td>X</td> <td>X</td> <td>X X X X X</td> </tr> <tr> <td>30</td> <td>X</td> <td>X</td> <td>X</td> <td>X</td> <td>X X X X X</td> </tr> <tr> <td>31</td> <td>X</td> <td>X</td> <td>X</td> <td>X</td> <td>X X X X X</td> </tr> <tr> <td>32</td> <td>X</td> <td>X</td> <td>X</td> <td>X</td> <td>X X X X X</td> </tr> <tr> <td>33</td> <td>X</td> <td>X</td> <td>X</td> <td>X</td> <td>X X X X X</td> </tr> <tr> <td>34</td> <td>X</td> <td>X</td> <td>X</td> <td>X</td> <td>X X X X X</td> </tr> <tr> <td>35</td> <td>X</td> <td>X</td> <td>X</td> <td>X</td> <td>X X X X X</td> </tr> <tr> <td>36</td> <td>X</td> <td>X</td> <td>X</td> <td>X</td> <td>X X X X X</td> </tr> <tr> <td>37</td> <td>X</td> <td>X</td> <td>X</td> <td>X</td> <td>X X X X X</td> </tr> <tr> <td>38</td> <td>X</td> <td>X</td> <td>X</td> <td>X</td> <td>X X X X X</td> </tr> <tr> <td>52*</td> <td></td> <td></td> <td></td> <td></td> <td>X X</td> </tr> <tr> <td>54*</td> <td></td> <td></td> <td></td> <td></td> <td>X X</td> </tr> </tbody> </table>	Programs Allowing P20 in Background	P20 Option					0	1	2	4	5	21**	X	X	X	X	X X X X X	27*	X	X	X	X	X X X X X	29**	X	X	X	X	X X X X X	30	X	X	X	X	X X X X X	31	X	X	X	X	X X X X X	32	X	X	X	X	X X X X X	33	X	X	X	X	X X X X X	34	X	X	X	X	X X X X X	35	X	X	X	X	X X X X X	36	X	X	X	X	X X X X X	37	X	X	X	X	X X X X X	38	X	X	X	X	X X X X X	52*					X X	54*					X X
Programs Allowing P20 in Background	P20 Option																																																																																																	
	0	1	2	4	5																																																																																													
21**	X	X	X	X	X X X X X																																																																																													
27*	X	X	X	X	X X X X X																																																																																													
29**	X	X	X	X	X X X X X																																																																																													
30	X	X	X	X	X X X X X																																																																																													
31	X	X	X	X	X X X X X																																																																																													
32	X	X	X	X	X X X X X																																																																																													
33	X	X	X	X	X X X X X																																																																																													
34	X	X	X	X	X X X X X																																																																																													
35	X	X	X	X	X X X X X																																																																																													
36	X	X	X	X	X X X X X																																																																																													
37	X	X	X	X	X X X X X																																																																																													
38	X	X	X	X	X X X X X																																																																																													
52*					X X																																																																																													
54*					X X																																																																																													
CP	Key V93E (if necessary) Sel Tot Att disp, 7.2.5 Sel Att Cont mode, 7.1	2,140	*UTFLAG set **Tracking only (no navigation) If one hour or more has elapsed since W-matrix initialization or if state vector has not been updated via P27.																																																																																															

(P20) UNIVERSAL TRACKING & RENDEZVOUS NAVIGATION

APOLLO-SOYUZ TEST PROJECT (ASTP)
OPERATIONS HANDBOOK

STA/T STEP	PROCEDURE	PANEL	REMARKS
CF	<p>1 Key V37E 2OE</p> <p>or If P31 through P38 sel P20 - on (auto) (P20 functions defined in each trgtng prog)</p>	2,140	<p>Manual selection of P20 (option zero automatically set). Other options available in step 2.</p> <p>MINKEY selection. If IMU on and aligned, P20 turned on automatically if programs P31 through P38 selected. This occurs whether or not rendezvous to be accomplished by MINKEY sequencing. P20 called to accomplish maneuver to tracking attitude, and various navigation tasks including VHF and optics tracking. No P20 displays are provided except FL V50 N18 in R60.</p>
2	<p>FL V04 N06 00024 (P20 option) 0000X</p> <p>Poss PROC alarm (4.8.1.16)</p>		<p>R02. (8.1.15)</p> <p>R2 initialized zero. If option zero desired, there is no choice but to use manual rendezvous sequence. If option 4 desired, either manual or MINKEY sequencing may be used. MINKEY, however, can only be performed using option 4. When a targeting program, P31 through P38 is called, option zero is automatically set. If not previously selected, P20 (option 4) will be automatically selected when MINKEY first initiated (PRO on FL V50 N25, R1 = 17).</p> <p>P20 options defined as follows:</p> <p>0 - Soyuz tracking (VECPPOINT). Point specified SC vector at Soyuz (no attitude constraint about pointing vector). After initial selection, new SC vector can be chosen without reselecting P20. P20 initializes N78 to preferred track attitude (0°, -35°, 0°).</p>

10.2.1

(P20) UNIVERSAL TRACKING & RENDEZVOUS NAVIGATION

NORMAL BACKUP.

APOLLO-SOYUZ TEST PROJECT (ASTP)
OPERATIONS HANDBOOK

STA/T STEP	PROCEDURE	PANEL	REMARKS
CP	Accept PRO Reject Key V22E Load desired option	2,140	<p>1 - Celestial body tracking (VECPOINT). Point specified SC vector at celestial body (no attitude constraint about pointing vector). After initial selection, new SC vector can be chosen without reselecting P20. However, P20 must be reselected to change target (celestial body) code (N70/N88). If P20 in foreground (PROG It = 20), P00 type integration will occur and P27 may be selected.</p> <p>2 - Rotation. Rotate about a specified SC vector. Current contents of N78 and N79 used only when rotation begins by P20 initiation, by V58E after RHC deflection, or by V37 to a tracking program following a program not allowing rotation. If P20 in foreground (PROG It = 20), P00 type integration will occur and P27 may be selected. Refer to 8.2.5 and 8.2.6 for PTC and orb rate procedures using option 2.</p> <p>4 - Soyuz tracking (3 axis). Point specified SC vector at Soyuz (hold attitude about pointing vector). After initial selection, new SC vector or azimuth constraint can be chosen without reselecting P20. P20 initializes N78 to preferred track attitude (0°, -35°, 0°).</p> <p>5 - Celestial body tracking (3-axis). Point specified SC vector at celestial body (hold attitude about pointing vector). After initial selection,</p> <p style="text-align: right;">...continued</p>

(P20) UNIVERSAL TRACKING & RENDEZVOUS NAVIGATION

**APOLLO-SOYUZ TEST PROJECT (ASTP)
OPERATIONS HANDBOOK**

STA/T STEP	PROCEDURE	PANEL	REMARKS
CP 3	FL V06 N78 (SC vctr angles) Y, P, az XXX.XX DEG Accept PRO Reject Key V25E Load desired data If presently rotating & new N78 contents to be used PHC - move from detent Key V58E If P47 previously sel during P20 Reload N78	2,140	<p>new SC vector or azimuth constraint can be chosen without reselecting P20. However, P20 must be reselected to change target (celestial body) code (N70/N88). If P20 in foreground (PROG lt = 20), P00 type integration will occur and P27 may be selected.</p> <p>For R2, a value of X = 3, 6 or 7 will be treated as X = 2.</p> <p>(Options 0, 1, 4, 5) If CMC/FREE or SCS control modes selected during these P20 options, desired attitude is computed but test for R60 is never made and, therefore, neither UPLINK ACTY lt nor FL V50 N18 will appear if attitude deviation unacceptable. Monitor mode II (V62E) FDAI attitude error needles when in SCS or CMC/FREE modes.</p> <p>All options.</p> <p>Program initializes N78 with values of preferred tracking attitude (0°, -35°, 0°) only if options 0 or 4 chosen. R1 & R2 (Y & P) are used to specify desired SC body vector to be pointed. The combination of P = 0° and Y = +90° is a constraint upon options 4 and 5 and should not be specified. Azimuth (R3) used only by options 4 and 5 to hold attitude about a specified SC vector. When MINKEY first initiated R3 automatically loaded to 000.00° if HDSUPFLG set, or +180.00° if HDSUPFLG reset.</p> <p>Selection of P47 during P20 destroys least significant half of N78 (R1); will cause incorrect N78 (R1 data) and may cause bad tracking or rotation.</p>

(P20) UNIVERSAL TRACKING & RENDEZVOUS NAVIGATION

10.2.1

NORMAL BACKUP

APOLLO-SOYUZ TEST PROJECT (ASTP)
OPERATIONS HANDBOOK

STA/T STEP	PROCEDURE	PANEL	REMARKS
CP 4	FL V06 N79 Rate DBD X.XXXX DEG/SEC XXX.XX DEG Reject Key V21E, V22E, V24E Load desired data Accept PRO Options 0 & 4, go to 8 1 & 5, go to 5 2, go to 7 If presently rotating & new N79 contents to be used RHC - move from detent or SC cont - CMC/HOLD SC CONT - CMC CMC MODE - HOLD CMC MODE - FREE (verify) Load new data Key V58E CMC MODE - AUTO	2,140	All options. If option 2, R1 & R2 displayed; for options 0, 1, 4 & 5, R2 only displayed. R2 initialized to current DAP deadband. Zero input causes 0.5° deadband to be employed. Maneuver rates for other than option 2 will be those computed as necessary to track the target. Stops rotation, allows initialization to new N79 values. Prevents collapsing desired deadband. Resumes rotation with new N79 values.
CP AC	FL V01 N70	2,140	Options 1 & 5. Celestial body to be pointed at. No specific values preloaded.

(P20) UNIVERSAL TRACKING & RENDEZVOUS NAVIGATION

APOLLO-SOYUZ TEST PROJECT (ASTP)
OPERATIONS HANDBOOK

STA/T STEP	PROCEDURE	PANEL	REMARKS
CP	Trgt code OOCDE 2,140 Reject Key V21E Load trgt code Accept PRO R1 = 00, go to 6 R1 > 00 & < 47, go to 8 Poss OPR ERR Recycles disp	2,140	Target codes: [In P20, source code (C) must be zero. Any non-zero digit turns on OPR ERR lt] 00 - Planet (any planet except earth) 01 to 45 - Star 46 - Sun 47 - Earth Target code negative or >47.
6	FL V06 M88 (planet only) X, Y, Z XXXXX	2,140	Options 1 & 5 (if N70 = 00). No specific values preloaded. Components of planet unit position vector at present time.
7	FL V06 M34 Time of event 00XX. HRS 000XX. MIN 0XX.XX SEC	1	Use on-board tables to determine planet position vector at present time. Option 2. Time to begin rotation. No specific time preloaded.
AC	Accept SC cont - CMC/AUTO SC CONT - CMC CMC MODE - AUTO	1	Schedules rotation about specified SC vector to begin at specified time (immediately if time in past).
CP	PRO 2,140	2,140	

10.2.1

(P20) UNIVERSAL TRACKING & RENDEZVOUS NAVIGATION

NORAL E55 K04

APOLLO-SOYUZ TEST PROJECT (ASTP)
OPERATIONS HANDBOOK

STA/T STEP	PROCEDURE	PANEL	REMARKS
CP	(R67, Rotation Maneuver Routine) Begin rotation (PRO on N34)		Option 2 - Provides capability of having DAP maintain a controlled rotational rate about a specified SC vector. Refer to 8.2.4 & 5 for orb rate/FTC (P20 option 2) procedures. Remaining P20 procedure does not apply to option 2.
AC	To stop rotation RHC - move from detent or SC cont - CMC/HOLD SC CONT - CMC CMC MODE - HOLD	1	Establishes attitude hold.
CP	To re-initiate rotation Key V58E To terminate mmvr Key V56E or Key V37E OOE (R61, Tracking Attitude Routine)	2,140	Re-establishes rotation to N78/N79 data (original or new data loaded). Terminates P20 and all options.
8 AC	Maneuver If mmvr <10° SC cont - CMC/AUTO SC CONT - CMC CMC MODE - AUTO Options 0 or 4, go to 10 Option 1 or 5, exit (R61 maintains track att)	1	Computes required gimbal angles & tracking attitude with present IMU orientation, extrapolates (periodically) CSM and Soyuz state vectors to present time and calculates LOS from CSM to Soyuz. Maneuver is performed so as to yield a minimum attitude maneuver. 9.2.1, note 10. If maneuver <10°, R61 performs maneuver to tracking attitude. R61 will continue to compute and maintain selected attitude (option) as long as SC cont - CMC/AUTO and RHC not moved out of detent. For maneuver <10°, remainder of P20 procedure does not apply to options 1 and 5.

(P20) UNIVERSAL TRACKING & RENDEZVOUS NAVIGATION

APOLLO-SOYUZ TEST PROJECT (ASTP)
OPERATIONS HANDBOOK

STA/T STEP	PROCEDURE	PANEL	REMARKS
AC	If mmvr $>10^\circ$, go to 9		If maneuver $>10^\circ$ and V50N18 flag set, calls R60 (R60 performs maneuver). V50N18 flag set by V37 processing (except P00) and on initial entry to P20.
CP	Poss PROG alarm Key V05 N09E (to verify alarm) 00401 (MGA excessive) Key V23 N78E Change N78 (R3) KEY REL		If maneuver $>10^\circ$ and V50N18 flag not set, lights UPLINK ACTY It. Opticas 4 and 5. Load value in R3 to reduce MGA to acceptable limit.
	If MGA $>75^\circ$ CMC goes to att hold RHC - manually mmvr to sel track att Key V58E		Prevents maneuver into gimbal lock.
	If mmvr $<10^\circ$ Option 0 or 4, go to 10 Option 1 or 5, exit (R61 maintains track att)		Sets V50N18 flag.
	If mmvr $>10^\circ$, go to 9 or Align IMU to acceptable orient, sec 13		

(P20) UNIVERSAL TRACKING & RENDEZVOUS NAVIGATION

10.2.1

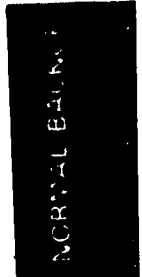

APOLLO-SOYUZ TEST PROJECT (ASTP)
OPERATIONS HANDBOOK

STA/T STEP	PROCEDURE	PANEL	REMARKS
CP	(R60, Attitude Maneuver Routine) (If UPLINK ACTY lt on Key V58E)	2,140	Maneuvers (auto or manual) to attitude specified by option selected and N78 data. R60 called only if maneuver >10° as determined by R61. Otherwise maneuver performed by R61. Must key V58E in order to get R60 (V50 N18). R61 resets V50N18 flag at completion of first R61 cycle; therefore, V58E required to set flag to allow R60 if subsequent auto maneuver >10° required.
9	Poss FL V50 N18 (auto mnvr request) (2 sec priority) If req angle change >10° R, P, Y XXX.XX DEG		DAP will point specified SC vector in direction of LOS to specified target. Required gimbal angles.
AC	Accept SC cont - CMC/AUTO SC CONT - CMC CMC MODE - AUTO PRO	1	This may be performed second time as attitude trim.
CP	V06 N18 R, P, Y XXX.XX DEG Monitor auto mnvr on FDAI Reject Key V62E RHC - null FDAI err needles Recycle 9	2,140	Priority display. At completion of maneuver, display will revert to FL V50 N18 (non-MINKEY only). Provides reference for manual maneuver.
AC	or SC CONT - SCS (or CMC mode # auto)	1	To update display without performing maneuver.

(P20) UNIVERSAL TRACKING & RENDEZVOUS NAVIGATION

APOLLO-SOYUZ TEST PROJECT (ASTP)
OPERATIONS HANDBOOK

STA/T STEP	PROCEDURE	PANEL	REMARKS
CP	PRO Recycle 9 When att satisfactory EWTR	2,140	<p>Terminates Attitude Maneuver Routine, R60. (Routine R61 will continue to compute and maintain selected attitude (option) as long as SC control CMC/AUTO and RHC not moved out of detent.) UPLINK ACTY light will be lit if V50N18 flag not set and tracking error, as determined by R61, >10 degrees. At this point, SXT marks can be taken. If VHF ranging enabled (V87E), VHF marks automatic. Navigation automatic until final computation requested, and optimized VHF range and range rate may be obtained by enabling R27 (step 16).</p> <p>Remainder of procedure applies to options 0 and 4 only.</p> <p>(Options 0 or 4). Points star LOS of optics at Soyuz during rendezvous tracking operations.</p> <p>Cycles R61 approximately every 2 seconds during rendezvous tracking operations (maintains tracking attitude).</p>

10.2.1 (P20) UNIVERSAL TRACKING & RENDEZVOUS NAVIGATION

10.2.1

NORMAL BACKUP

APOLLO-SOYUZ TEST PROJECT (ASTP)
OPERATIONS HANDBOOK

STA/T STEP	PROCEDURE	PANEL	REMARKS
CP 10	OPT ZERO - ZERO OPT MODE - CMC If TA > 50° (options 0 & 4)	122	6.1.3, note 4g. Trunnion driven to upper limit (≈49.7754°) and held at this angle.
AC	RHC - mvr to reduce TA or SC cont - CMC/AUTO SC CONT - CMC CMC MODE - AUTO If RHC moved from detent Key V58E	1 2,140	Key V16 M22E for desired gimbal angles.
CP 11	OPT MODE - MAN OHC - ctr trgt in SXT MARK pb - push Accept Repeat mrk proced or OPT MODE - CMC Go to 15 Reject MARK REJ pb - push Repeat mrk proced	122	Required for centering target using OHC. If more marks desired. If any mark results in excessive update, priority display FL V06 N49, step 15, will interrupt program and display magnitude of excessive update. If sufficient marks have been made. Should be done promptly (within 7 seconds) to ensure mark has not been processed.

(P20) UNIVERSAL TRACKING & RENDEZVOUS NAVIGATION

APOLLO-SOYUZ TEST PROJECT (ASTP)
OPERATIONS HANDBOOK

STA/T STEP	PROCEDURE	PANEL	REMARKS
CP	<p>Poss PROG alarm Key V05 N09E (to verify alarm) 00121 (att rate >two-thirds deg/sec)</p> <p>(R23, Backup Rendezvous Tracking Sighting Mark Routine)</p>	2,140	Sighting marks automatically rejected.
12	Key V54E		(Options 0 & 4). To perform sighting marks on Soyuz using backup optics (COAS).
13	<p>FL V06 N94 SA TA</p> <p>Accept PRO Reject Key V24E Load desired data</p>	<p>XXX.XX DEG XX.XXX DEG</p>	<p>Values obtained from COAS calibration, 13.1.8 Nominal SA and TA for COAS sightings are: SA - 000.00 DEG TA - 57.470 DEG</p>
14	<p>FL V53 N45 (request alt LOS mrk) Mrks (VHF/opt)</p>	XXBXX MKS	<p>Number of marks processed by R22. Two most significant digits display VHF ranging marks. Two least significant digits display optics marks [either SXT or backup optics (COAS) marks]. (If V87E, VHF marks accumulated automatically.) Optics marks may be taken any time P20 operating (after maneuver to sighting attitude).</p>

(P20) UNIVERSAL TRACKING & RENDEZVOUS NAVIGATION

10.2.1

NDR, AL BACKUP

APOLLO-SOYUZ TEST PROJECT (ASTP)
OPERATIONS HANDBOOK

STA/T STEP	PROCEDURE	PANEL	REMARKS
CP	TF GETI (next burn)	XXBXX MIN-SEC 2,140	Contents dependent on external programs. If P20 only, display static. Constraint - R2 cannot be >59B59 at this point. If TF GETI >59 min 59 sec, display is limited. N35 may be used to get full time to ignition.
	MGA (next burn)	XXX.XX DEG	Contents dependent on external programs. If P20 only, display static.
	RHC - align Soyuz in COAS EMTR		Alternate LOS mark.
	Accept Repeat mrk proced		If more marks desired.
	or Wait 15 sec		To allow processing of final mark.
	PRO		If sufficient marks have been made. To ensure processing of last mark, wait 15 seconds before proceeding. This allows for previous marks to be processed. If PRO done too soon, last mark may be treated as a prime rather than a backup mark.
	Reject V86L Repeat mrk proced		Rejects previous mark. Should be done promptly (within 7 seconds) to ensure mark has not been processed.

(P20) UNIVERSAL TRACKING & RENDEZVOUS NAVIGATION

APOLLO-SOYUZ TEST PROJECT (ASTP)
OPERATIONS HANDBOOK

STA/T STEP	PROCEDURE	PANEL	REMARKS
CP 15	Poss FL V06 N49 (2 sec priority) AR ΔV Source code 0000X.	2,140 XXX.XX NM XXXX.X FPS	(Options 0 & 4). Processes optics and VHF ranging data in accordance with status of FULTKFLG and integrates CSM and Soyuz state vectors to present time. Nominally, CSM state vector is automatically selected for incorporation by initial entry to P20. V80 and V81, however, are also available for selecting Soyuz and CSM state vector update respectively. For FULTKFIG status, or change, refer to 8.3.5. Excessive update parameters. To change ΔR and ΔV threshold values, refer to 8.1.10. 00001 = Optics (CMC does not differentiate between SXT and COAS marks). 00002 = VHF ranging. For this option, refer to 5.6.3. Priority display. Will not respond to DSKY input until after 2 seconds. Incorporates update data. Does not incorporate update data. Provides method of obtaining optimized measurements of VHF range and range rate, and φ, either for present time or for a desired time specified via N72. The time interval for optimizing range rate should be chosen so as not to conflict with final computations for a targeting solution. Targeting solutions should be obtained after recording optimized results in N77.

10.2.1

(P20) UNIVERSAL TRACKING & RENDEZVOUS NAVIGATION

NORMAL BACKUP

APOLLO-SOYUZ TEST PROJECT (ASTP)
OPERATIONS HANDBOOK

STA/T STEP	PROCEDURE	PANEL	REMARKS
CP 16	Key V76E	2,140	Enables R27 in R22.
	Poss OPR ERR Exit		If another extended verb active.
17	FL V06 N72 T (R27 optimized)	00XX. HRS 00XX. MIN 0XX.XX SEC	
	Accept PRO Reject Key V25E Load GET for optimization		
18	Obtain current R & R dot Key V16 N76E R R dot TFO (- closing)	XXX.XX MM XXX.X FPS XXBX MIN-SEC	Range. Range rate. Time from R27 optimization(counting to N72 time).
19	Monitor R3 → 0 Center Soyuz in opt FOV With Soyuz centered and R3 = 0 MARK		

(P20) UNIVERSAL TRACKING & RENDEZVOUS NAVIGATION

APOLLO-SOYUZ TEST PROJECT (ASTP)
OPERATIONS HANDBOOK

STA/T STEP	PROCEDURE	PANEL	REMARKS
CP 20	Obtain optimized values of R, R dot & ϕ Key N77E R R dot (- closing) ϕ Record N77 data V77E Go to trgting prog	2,140 XXX.XX NM XXXX.X FPS XXX.XX DEG	Displays latest optimized range and range rate. ϕ computed for last N72 time. Disables R27 in R22.
21	To term P20 & all other prog running Key V37E 00E		6.1.3, note 3r.
or	To term P20 only Key V56E		If V56E keyed in during computation in P35/P36, these computations will be restarted from beginning.
22	Set opt cont OPT ZERO - ZERO OPT PWR - OFF RETCL BRT tv - DIM	122 100 122	FL V37 only if no other program active.

10.2.1

(P20) UNIVERSAL TRACKING & RENDEZVOUS NAVIGATION

NORMAL BACKUP

APOLLO-SOYUZ TEST PROJECT (ASTP)
OPERATIONS HANDBOOK

STA/T STEP	PROCEDURE	PANEL	REMARKS
10.2.2	(P25) Contingency VHF Range Rate		
CMC - on (req), 8.1.3	VHF AM ranging mode sel (req), 5.6.3		Displays range and range rate from a source independent of vehicle state vectors. Allows selection of a time at which range rate will be optimized.
CP 1	Key V37E 25E	2,140	
2	FL V06 N72 T (R27 optimized)	00XX. HRS 00XX. MIN OXX.XX SEC	No R27 optimization if zeros loaded in N72.
	Accept PRO Reject Key V25E Load desired data		
	If N72 = 0, go to 4		
3	FL V16 N76 R R dot (-closing)	XXX.XX NM XXX.X FPS	Range (updated at a 2-second interval). Range rate. Updated at 2-second interval.
	TFO	XXBXX MIN SEC	Time from R27 optimization updated at 1-second interval (59B59 = no R27 optimization).
	Accept PRO Reject Key V32E Return to 2		To respecify additional optimization time.

(P25) CONTINGENCY VHF RANGE RATE

APOLLO-SOYUZ TEST PROJECT (ASTP)
OPERATIONS HANDBOOK

STA/T STEP	PROCEDURE	PANEL	REMARKS
CP 4	FL V16 M77 R R dot (-closing) 0/φ Accept PRO Reject Key V32E Return to 2	2,140 XXX.XX NM XXXX.X FPS -00001 code	If N72 = 0 R, R dot = current values If N72 ≠ 0 TFO < -01B35, R, R dot = current values -01B35 < TFO < +00B02, R, R dot fixed at last current value +00B02 < TFO < +01B35, R, R dot = optimizing values. TFO > +01B35, R, R dot = optimized values New optimization is done every 4 minutes. To optimize R dot for new N72 time.
CP 5	FL V37 Key XXE		

(P25) CONTINGENCY VHF RANGE RATE

10.2.2

NORMAL BACKUP

APOLLO-SOYUZ TEST PROJECT (ASTP)
OPERATIONS HANDBOOK

STA/T STEP	PROCEDURE	PANEL	REMARKS
10.2.3	(V83) Rendezvous Parameter Display #1 (R31)		Displays CMC calculated rendezvous parameters (range, range rate, and theta).
	CMC - on (req), 8.1.3 ISS - on & orient known (req), 8.1.3 & sec 13		Required for meaningful display of theta.
CP 1	Key Vb3E	2,140	V83 automatically executed for P37 (Final Pendevous Parameters) during MINKEY sequence. (Refer to 11.2.7.)
	Poss OPR ERR		If another extended verb active.
2	FL V16 N54 Range	XXX.XX NM	Display updated at 2-second intervals. Range and range rate based on stored state vectors. Range and range rate displays may degrade considerably at ranges below ≈ 0.3 to 0.5 NM depending on marking schedules and resultant CMC navigation accuracy. Once this routine has started, changes to state vector caused by optics mark or VHF sample will not be reflected in displayed parameters.
	Range rate	XXXX.X FPS	(-) range rate indicates closing. This calculation not sufficiently accurate for reliable terminal closing values. It should not be utilized without good visual cues.
	Theta (lcl horiz/ CSM +X)	XXX.XX DEG	Theta - Angle included between +Xsc axis and local horizontal. Angle in range 0° to 180° indicates +Xsc axis is above local horizontal plane. Total range: 0° to 360° .
	PRO Return to prog in progress		

APOLLO-SOYUZ TEST PROJECT (ASTP)
OPERATIONS HANDBOOK

STA/T STEP	PROCEDURE	PANEL	REMARKS
10.2.4	(V85) Rendezvous Parameter Display #2 (R34)		Displays CMC calculated rendezvous parameters (range, range rate, and phi).
	CMC - on (req), 8.1.3 ISS - on & orient known (req), 8.1.3 & sec 13 Opt pwr up (req), 8.1.4		Required for meaningful display of phi. Required for meaningful display of phi.
CP 1	Key V85E	2,140	
	Poss OPR ERR		If another extended verb active.
2	FL V16 H53		Display updated at 2-second intervals.
	Range Range rate	XXX.XX NM XXXX.X FPS	Range and range rate computed based on stored Soyuz and CSM state vectors. (-) range rate indicates closing. Range and range rate displays may degrade considerably at ranges below ≈0.3 to 0.5 NM depending on marking schedules and resultant CMC navigation accuracy. Once this routine has started, changes to state vector caused by optics mark or VHF sample will not be reflected in displayed parameters.
	Phi (lcl horiz/ SLOS)	XXX.XX DEG	Phi - Angle included between optics star line-of-sight and local horizontal. Angle in range 0° to 180° indicates SLOS is above local horizontal plane. Total range: 0° to 360°.
	PRO Return to prog in progress		

(V85) RENDEZVOUS PARAMETER DISPLAY #2 (R34)

10.2.4

NORMAL BACKUP

APOLLO-SOYUZ TEST PROJECT (ASTP)
OPERATIONS HANDBOOK

STA/T STEP	PROCEDURE	PANEL	REMARKS
10.2.5	(V90) Rendezvous Out of Plane Display (R36)		Displays CMC calculated rendezvous out-of-plane parameters.
CMC - on (req), 8.1.3		2,140	
CP 1	Key V90E		If another extended verb active.
2	FL V06 N16 GET event	00XX. HRS 00XX. MIN 0XX.XX SEC	GET for which out-of-plane parameters desired. N16 initialized to TIC(N33) before this display. (Present time indicated by all zeros.)
Accept PRO	Key V25E	Load desired GET event	
3	FL V06 N96 (rndz out of plane param) Y (CSM) Y dot (CSM) Y dot (Soyuz)	XXX.XX NM XXXX.X FPS XXXX.X FPS	To obtain additional data point.
Accept PRO	Exit R36		
Reject Key V32E	Return to 2 (adjust GET event)		

(V90) RENDEZVOUS OUT OF PLANE DISPLAY (R36)

APOLLO-SOYUZ TEST PROJECT (ASTP)
OPERATIONS HANDBOOK

STA/T STEP	PROCEDURE	PANEL	REMARKS
10.2.6	(V89) Rendezvous Final Attitude (R63)		
	CMC - on (req), 8.1.3		Calculates final gimbal angles required to point either CSM +X axis or preferred tracking axis at SWS.
	ISS - on & orient known (req), 8.1.3 & sec 13		Provides auto maneuver to selected attitude by calling R60.
	SCS - on (desired), 8.4.2		
	RCS DAP - load & activate (req), 8:2.1		
CP	1 Key V37E 00E	2,140	R63 may be selected from P00 only.
	2 Sel ISS Tot Att Disp, 7.2.5		Both FDAIs recommended so that either reference system (IMU or GDC) may be monitored. (CMC attitude error and rate display available.)
	3 Key V89E		R02. (8.1.15)
	4 FL V06 N78 (SC vctr angles) Y, P		R1 and R2 initialized zero, R3 blanked.
	5 FL V06 N18 (computed GMBL angles) R, P, Y		Computed required gimbal angles at selected tracking attitude as determined by N78 inputs if present IMU orientation maintained.

10.2.6

(V89) RENDEZVOUS FINAL ATTITUDE (R63)

NORMAL BACKUP

APOLLO-SOYUZ TEST PROJECT (ASTP)
OPERATIONS HANDBOOK

STA/T STEP	PROCEDURE	PANEL	REMARKS
CP	Accept PRO Reject Key V32E (to update disp) or Key V34E (to term routine) (R60, Attitude Maneuver Routine)	2,140	Provides maneuver (automatic or manual) to attitude selected in 4. Required gimbal angles.
6	FL V50 N18 (auto mnvr request) R, P, Y XXX.XX DEG		
AC	Accept SC cont - CMC/AUTO SC CONT - CMC CMC MODE - AUTO PRO	1	
CP	Go to 7 Reject Key V62E RHC - null FDAI err needles	2,140	Provides reference for manual maneuver.
AC	or SC CONT - SCS (or CMC MODE ≠ AUTO)	1	Recomputes desired attitude without performing auto maneuver.
CP	PRO (to update disp) Recycle 6 or ENTR Exit R60/R63	2,140	Terminates R60.
7	V06 N18 (auto mnvr) R, P, Y XXX.XX DEG Mon auto mnvr on FDAI Return to 6		Non-flashing display until completion of auto maneuver, then returns to FL V50 N18. Maneuver rates will be as specified by last DAP data load (R03). When maneuver complete.

(V89) RENDEZVOUS FINAL ATTITUDE (R63)

APOLLO-SOYUZ TEST PROJECT (ASTP)
OPERATIONS HANDBOOK

STA/T STEP	PROCEDURE	PANEL	REMARKS
10.2.7	<u>(P77) Target Delta V</u>		P77 provides CSM maneuver parameters for updating CMC knowledge of CSM state vector.
CP	CMC - on (req), 8.1.3		Keying V34E terminates P77 at any flashing display.
1	Key V37E 77E	2,140	
2	FL V06 N33 GETI	00XX. HRS 00XX. MIN 0XX.XX SEC	
3	FL V06 M81 AVX, Y, Z (CSM 1c1 vert)	XXXX.X FPS	CMC updates CSM state vector.
4	FL V37 Key XXE		

(P77) TARGET DELTA V

10.2.7

NORMAL BACKUP

APOLLO-SOYUZ TEST PROJECT (ASTP)
OPERATIONS HANDBOOK

STA/T STEP	PROCEDURE	PANEL	REMARKS
11.0	PRETHRUSTING		For general G&C operating data, refer to operating notes, 6.1.1.
11.1	ORBIT CHANGE PRETHRUSTING		
11.1.1	<u>(P30) External Delta V Prethrusting</u>		Accepts targeting parameters from sources external to CMC and computes, therefrom, required velocity and other initial conditions required by CMC for execution of ΔV maneuver. Targeting parameters include time of ignition (TIG) and impulsive ΔV along CSM local vertical axes at TIG. P30 displays, to flight crew and STDN, certain specific dependent variables associated with desired maneuver for approval by flight crew/STDN.
CP 1	CMC - on (req), 8.1.3 ISS - on & orient known (desired), 8.1.3 & sec 13 Key V37E 30E	2,140	ISS must be on and its orientation known to obtain middle gimbal display (step 5). At this point, P30 sets TRACK and UPDATE flags.
2	FL V06 N33 GETI, stored		
	Accept Red GETI PRO		
	Reject V25E, load desired GETI		
3	FL V06 N81 (VG compnts) VGX, Y, Z (lcl vert at GETI)		Stored VG components along local vertical axes at GETI.

11.1.1

(P30) EXTERNAL DELTA V PRETHRUSTING

NORMAL BACKUP

APOLLO-SOYUZ TEST PROJECT (ASTP)
OPERATIONS HANDBOOK

STA/T STEP	PROCEDURE	PANEL	REMARKS
33	<p>Accept PRO Reject V25E, load desired data</p> <p>4 FL V06 N42 (calculated thrust parameters) Ha XXXX.X NM Hp XXXX.X NM ΔV (req) XXXX.X FPS</p> <p>Coord parameters with STDm (if available)</p> <p>Accept PRO Reject Reselect P30 or P27, load new parameters</p>	2,140	<p>PRO option resets UPDATE flag and sets external ΔV flag.</p> <p>Altitudes above launch pad radius. Measurements are limited to 9999.9 NM. Calculated Ha and Hp in P30 are considerably in error for long burns and should be ignored because parameters are computed (assuming an impulsive ΔV) at time of ignition along CSM local vertical axis. ΔV is magnitude of the impulsive ΔV vector at GETI.</p>
5	<p>FL V16 N45 Mrks (VHF/opt) XXBXX MKS</p>		<p>Number of marks processed by R22. Two most significant digits display VHF ranging marks. Two least significant digits display optics marks [either SXT or backup optics (COAS) marks]. Optics mark counter does not distinguish between backup and primary marks.</p>
-59:59	<p>TF GETI (next burn) XXBXX MIN-SEC</p> <p>MGA (next burn) XXX.XX DEG</p> <p>Rcd values PRO Align GDC to IMU, 8.4.6</p>		<p>Constraint - R2 cannot be >59B59 at this point. If TF GETI >59 min 59 sec, display limited. For full time to ignition display, use N35.</p> <p>MGA is displayed as -00002 at this point if IMU not on and orientation known (REFSMFLG reset). Otherwise, MGA at GETI displayed if CSM +X axis aligned with initial thrust direction.</p>

(P30) EXTERNAL DELTA V PRETHRUSTING

APOLLO-SOYUZ TEST PROJECT (ASTP)
OPERATIONS HANDBOOK

STA/T STEP	PROCEDURE	PANEL	REMARKS
CP 6 FL V37 Key XXE	Go to (P40) G&N/SPS Thrusting, 12.2.1 or (P41) G&N/SM RCS Thrusting, 12.2.2 or SCS Thrusting, 12.3 or (P52) IMU Realign, 13.1.3	2,140	If average G on, R00 turns off average G. It also sets or resets RNDVZFLG, TRACK, and UPDATE flags, depending on which programs in progress or called, and may recycle into P20 under certain conditions. IMU realign should be selected if MGA unsatisfactory in step 5.

11.1.1
(P30) EXTERNAL DELTA V PRETHRUSTING

NORMAL BACKUP

APOLLO-SOYUZ TEST PROJECT (ASTP)
OPERATIONS HANDBOOK

STA/T STEP	PROCEDURE	PANEL	REMARKS
11.2	RENDEZVOUS PRETHRUSTING		
11.2.1	(P31) Normal Corrective Maneuver #1 (NCL)		
	CMC - on (req), 8.1.3		
	ISS - on & orient known (desired), 8.1.3 & sec 13		
	DAP - load & activate (desired), 8.2.1		
CP 1	Key V37E 31E	2,140	Calculates and displays parameters associated with NCL maneuver and ΔV burn. Keying V34E terminates P31 at any flashing display. Based on stored target parameters, the following parameters are computed and stored: TIG(NC2) in N28 ΔV(NC2) in N84 TIG(NCC) in N11 ΔH(NC2) in N84 TIG(NSR) in N13 ΔV(NCC) in N84 ΔV(NCL-LV) in N81 ΔV(NSP-LV) in N82 Refer to 9.2 for additional data on the MINKEY rendezvous sequence. Required for MINKEY and for meaningful MGA display during final N45 display (step 8). Required for auto maneuver to tracking attitude.
2	FL V50 N25 OOO17 (request MINKEY)		If IMU on and aligned, P20 automatically turned on when P31 selected. P31 however, can be selected without P20 in background. Displayed for selection of MINKEY rendezvous sequence. Will occur here only if P31 selected as entry point to MINKEY sequence via V37E. If PPO, will not occur in subsequent programs. PRO initiates MINKEY rendezvous sequence. EMP allows manual sequencing. If not previously selected, P20 (option 4) would now be automatically selected and N78 (P3) in P20 would be loaded as determined by state of HDSUPPLG. Also refer to 9.2.1, note 2.
	PRO (MINKEY) EMTR (manual) Go to 3		

(P31) NORMAL CORRECTIVE MANEUVER #1 (NCL)

APOLLO-SOYUZ TEST PROJECT (ASTP)
OPERATIONS HANDBOOK

STA/T STEF	PROCEDURE	PANEL	REMARKS
	(R61, Tracking Attitude Routine)		Computes specified tracking attitude [computes required gimbal angles at tracking attitude (specified by N78) with present IMU orientation]. The CMC will compute and execute appropriate maneuver (R61/R60).
3	Maneuver		9.2.1, note 10.
CP	If mnvr <10° SC cont - CMC/AUTO SC CONT - CMC CMC MODE - AUTO Go to 5	2,140	If maneuver <10°, R61 performs maneuver to tracking attitude.
	If mnvr >10°, go to 4		If maneuver >10° and V50N18 flag set, calls R60 (R60 performs maneuver). V50N18 flag set by V37 processing (except P00) and on initial entry to P20.
	Poss PROG alarm Key V05 N09E (to verify alarm) 00401 (MGA excessive)		If maneuver >10° and V50N18 flag not set, lights WPLINK ACTY light.
	If MGA >75° CMC goes to att hold RHC - manually mnvr to sel track att Key V58E If mnvr <10°, go to 5 If mnvr >10°, go to 4		P20 (option 4).
	or Align IMU to acceptable orient, sec 13		Prevents maneuver into gimbal lock. Sets V50N18 flag.

11.2.1 (P31) NORMAL CORRECTIVE MANEUVER #1 (NC1)

NORMAL BACKUP

APOLLO-SOYUZ TEST PROJECT (ASTP)
OPERATIONS HANDBOOK

STA/T STEP	PROCEDURE	PANEL	REMARKS
	(R60, Attitude Maneuver Routine)		Controller selects P20. Provides for maneuver (auto or manual) to attitude specified by option selected and N78 data. R60 called only if maneuver $\geq 10^\circ$ as determined by R61. Otherwise maneuver performed by R61.
	(If UPLINK ACTY lt on Key V58E)		Must key V58E in order to get R60 (V50 N18). R61 resets V50N18 flag at completion of first R61 cycle; therefore, V58E required to set flag to allow R60 if subsequent auto maneuver $\geq 10^\circ$ required.
CP	4 Poss FL V50 N18 (auto mnvr request) (2 sec priority) If req angle change $\geq 10^\circ$	2,140	DAP will point specified (N78) axis at Soyuz.
	R, P, Y XXX.XX DEG		Required gimbal angles.
AC	Accept SC cont - CMC/AUTO SC CONT - CMC CMC MODE - AUTO PRO	1	This may be performed second time as attitude trim.
CP	V06 N18 R, P, Y XXX.XX DEG Monitor auto mnvr on FDAI Reject Key V62E RHC - null FDAI error needles Recycle 4	2,140	Priority display. At completion of maneuver, display will revert to FL V50 N18 (non-MINKEY only). Provides reference for manual maneuver.
AC	or SC CONT - SCS (or CMC mode # auto) PRO	1	To update display without performing maneuver.
CP	Recycle 4	2,140	

(P3.) NORMAL CORRECTIVE MANEUVER #1 (NC1)

APOLLO-SOYUZ TEST PROJECT (ASTP)
OPERATIONS HANDBOOK

STA/T STEP	PROCEDURE	PANEL	REMARKS
CP	When att satisfactory ENTR, go to 5	2,140	Terminates Attitude Maneuver Routine, R60. (Routine R61 will continue to compute and maintain selected attitude (option) as long as SC control CMC/AUTO and RHC not moved out of detent.) UPLINK ACTY light will be lit if V50N18 flag not set and tracking error, as determined by R6i, >10 degrees. At this point, SXT marks can be taken. [For mark procedure, refer to (P20) 10.2.1, step 11.] If VHF ranging enabled (V87E), VHF marks automatic. Navigation automatic until final computation request.
5	FL V06 N95 GETI (NCL)	OOXX. HRS OOXX. MIN OXX.XX SEC	If P31 first program called in MINKEY sequence, GETI (NCL) must be loaded.
6	FL V06 N57 1/2 revs ΔH (NCC) ΔH (NSR) .	XXXX. XXXX.X NM XXXX.X NM	Number of 1/2 revs between NCL and NC2.
	Accept Rcd GETI (NCL) PRO		
	Reject Key V25E Load desired GETI (NCL)		
	Accept Rcd data PRO		
	Reject Key V25E Load desired data		

11.2.1

(P31) NORMAL CORRECTIVE MANEUVER #1 (NCL)

NORMAL BACKUP

APOLLO-SOYUZ TEST PROJECT (ASTP)
OPERATIONS HANDBOOK

STA/T STEP	PROCEDURE	PANEL	REMARKS
CP 7	FL V06 N37 GETI (TPI)	2,140	
	OOXX. HRS OOXX. MIN OXX.XX SEC		
	Accept Rcd GETI (TPI) PRO		
	Reject Key V25E Load desired GETI (TPI)		
8	FL V16 N45 (mvr data) Marks	XXBXX MKS	Number of marks processed by R22. Two most significant digits display VHF ranging marks. Two least significant digits display optics marks [either SXT or backup optics (COAS) marks]. (If V87E, VHF marks accumulated automatically.) Optics marks may be taken any time P20 operating.
	TF GETI (NCL)	XXBXX MIN-SEC	Time from NCL ignition. Maximum reading 59B59. --, before; +, after.
	MGA	-0000X	-00001 for other than final pass. -00002 final pass, IMU not aligned.
	or IMU aligned	+XX.XX DEG	Middle gimbal angle (yaw): +XX.XX DEG for final pass and IMU aligned (if +X axis aligned to initial thrust direction).
	To continue mark process Key V32E, go to 9		CMC computes NCC and NSR parameters.

(P31) NORMAL CORRECTIVE MANEUVER #1 (NCL)

APOLLO-SOYUZ TEST PROJECT (ASTP)
OPERATIONS HANDBOOK

STA/T STEP	PROCEDURE	PANEL	REMARKS
CP	<p>or To terminate mark process & do final pass Wait 15 sec PRO, go to 9</p> <p>Poss FL V05 N09 00600 failure in phase match iterations 00601 failure in either NC2 or NCC height mmvr iterations 00602 failure in outer (phase) loop iterations 00603 failure in QDTP1 iterations</p> <p>Key V32E Return to 5</p> <p>or PRO If 00600, 00601, or 00603 Go to 10</p> <p>or After final pass PRO, go to 11</p>	<p>2,140</p>	<p>Allows processing of final mark. CMC computes NCC and NSR parameters.</p> <p>To adjust input parameters. Continue program without recycle.</p>
9	<p>FL V06 N84 ΔV (NC2) ΔH (NC2) ΔV (NCC)</p> <p>Rcd data PRO</p>	<p>XXXX.X FPS XXXX.X NM XXXX.X FPS</p>	

11.2.1

(P31) NORMAL CORRECTIVE MANEUVER #1 (NCI)

NORMAL BACKUP

APOLLO-SOYUZ TEST PROJECT (ASTP)
OPERATIONS HANDBOOK

STA/T STEP	PROCEDURE	PANEL	REMARKS
CP 10	FL V06 N81 VGX, Y, Z (NCL)	2,140	CMC calculated components of VG (in local vertical coordinates) for NCL. N81 values will be zero if PRO after alarms 00600, 00601, or 00603 (step 8).
11	Rcd data PRO, return to 8 FL V37 Key XXE		For MINKEY, W-matrix reinitialization values are changed to 2K ft and 2 fps. If VG computed to be >10 fps, controller proceeds to P40 sequence. If VG <10 fps, controller proceeds to P41.

(P31) NORMAL CORRECTIVE MANEUVER #1 (NCL)

APOLLO-SOYUZ TEST PROJECT (ASTP)
OPERATIONS HANDBOOK

STA/T STEP	PROCEDURE	PANEL	REMARKS
11.2.2	<p>(P32) Normal Corrective Maneuver #2 (NC2)</p> <p>CMC - on (req), 8.1.3 ISS - on & orient known (desired), 8.1.3 & sec 13 LAP - load & activate (desired), 8.2.1</p> <p>1 If MINKEY auto call Go to 3</p> <p>CP or Key V37E 32E</p>	2,140	<p>Calculates and displays parameters associated with NC2 maneuver and ΔV burn.</p> <p>Successful completion dependent upon assumptions:</p> <ol style="list-style-type: none"> Prescribed angle (E) exists at selected GETI (TPI). Computed variables may be stored for later STDN verification. <p>P32 can be selected manually (manual rendezvous sequence) or automatically by MINKEY controller (MINKEY rendezvous sequence).</p> <p>Keying V34E terminates P32 at any flashing display.</p> <p>Based on stored target parameters, the following parameters are computed and stored:</p> <p>TIG(NCC) in N11 ΔV(NCC) in N84 TIG(NSR) in N13 ΔV(NSR) in N84 ΔV(NC2-LV) in N81 ΔV(NSR-LV) in N82</p> <p>Refer to 9.2 for additional data on the MINKEY rendezvous sequence.</p> <p>Required for MINKEY and for meaningful MGA display during final N45 display (step 8).</p> <p>Required for auto maneuver to tracking attitude.</p> <p>If MINKEY selected in P31, P32 automatically called by MINKEY controller at completion of NC1 sequence.</p> <p>If IMU on and aligned, P20 automatically turned on. P32 however, can be selected without P20 in background.</p>

(P32) NORMAL CORRECTIVE MANEUVER #2 (NC2)

11.2.2

NORMAL BACKUP

APOLLO-SOYUZ TEST PROJECT (ASTP)
OPERATIONS HANDBOOK

STA/T STEP	PROCEDURE	PANEL	REMARKS
CF 2	FL V50 N25 00017 (request MINKEY) PRO (MINKEY) ENTR (manual) Go to 3	2,140	Occurs only if MINKEY sequence initiated at this point. PRO initiates MINKEY rendezvous sequence. ENTR allows manual sequencing. If not previously selected, P20 (option 4) would now be automatically selected and N78 (R3) in P20 would be loaded as determined by state of HDSUPFLG. Also refer to 9.2.1, note 9.
3	Maneuver If mnvr <10° SC cont - CMC/AUTO SC CONT - CMC CMC MODE - AUTO Go to 5 If mnvr >10°, go to 4	(R61, Tracking Attitude Routine)	Computes specified tracking attitude [computes required gimbal angles at tracking attitude (specified by N78) with present IMU orientation]. The CMC will compute and execute appropriate maneuver (R61/R60). 9.2.1, note 10. If maneuver <10°, R61 performs maneuver to tracking attitude. If maneuver >10° and V50N18 flag set, calls R60 (R60 performs maneuver). V50N18 flag set by V37 processing (except P00) and on initial entry to P20. If maneuver >10° and V50N18 flag not set, lights UPLINK ACTY light. P20 (option 4).

(P32) NORMAL CORRECTIVE MANEUVER #2 (NC2)

APOLLO-SOYUZ TEST PROJECT (ASTP)
OPERATIONS HANDBOOK

STA/T STEP	PROCEDURE	PANEL	REMARKS
CP	<p>If MGA >75° CMC goes to att hold RHC - manually mnvr to sel track att Key V58E If mnvr <10°, go to 5 If mnvr >10°, go to 4</p> <p>or Align IMU to acceptable orient, sec 13 (R60, Attitude Maneuver Routine)</p> <p>(If UPLINK ACTY 1t on key V58E)</p>	2,140	<p>Prevents maneuver into gimbal lock.</p> <p>Sets V50N18 flag.</p>
AC	<p>4 Poss FL V50 N18 (auto mnvr request) (2 sec priority) If req angle change >10°</p> <p>R, P, Y XXX.XX DEG</p> <p>Accept SC cont - CMC/AUTO 1 SC CONT - CMC CMC MODE - AUTO PRO</p>		<p>Controller selects P20. Provides for maneuver (auto or manual) to attitude specified by option selected and N78 data. R60 called only if maneuver >10° as determined by R61. Otherwise maneuver performed by R61.</p> <p>Must key V58E in order to get R60 (V50 N18). R61 resets V50N18 flag at completion of first R61 cycle; therefore, V58E required to set flag to allow R60 if subsequent auto maneuver >10° required.</p> <p>DAP will point specified (N78) axis at Soyuz.</p> <p>Required gimbal angles.</p>
CP	<p>V06 N18 R, P, Y XX.XX DEG Monitor auto mnvr on FDAI</p>	2,140	<p>This may be performed second time as attitude trim.</p> <p>Priority display. At completion of maneuver, display will revert to FL V50 N18 (non-MINKEY only).</p>

11.2.2

(P32) NORMAL CORRECTIVE MANEUVER #2 (NC2)

NORMAL BACKUP

APOLLO-SOYUZ TEST PROJECT (ASTP)
OPERATIONS HANDBOOK

STA/T STEP	PROCEDURE	PANEL	REMARKS
CP	Reject Key V62E RHC - null FDAI error needles Recycle 4	2,140	Provides reference for manual maneuver.
AC	or SC CONT - SCS (or CMC mode ≠ auto)	1	To update display without performing maneuver.
CP	PRO Recycle 4 When att satisfactory EWTR, go to 5	2,140	Terminates Attitude Maneuver Routine, R60. (Routine R61 will continue to compute and maintain selected attitude (option) as long as SC control CMC/AUTO and RHC not moved out of detent.) UPLINK ACTY light will be lit if V50N18 flag not set and tracking error, as determined by R61, >10 degrees. At this point, SXT marks can be taken. [For mark procedure, refer to (P20) 10.2.1, step 11]. If VHF ranging enabled (V87E), VHF marks automatic. Navigation automatic until final computation request.
5	FL V06 N28 GETI (NC2)		
	Accept Rcd GETI (NC2) PRO		
	Reject Key V25E Load desired GETI (NC2)		
6	FL V06 N57 R2 ΔH (NCC) R3 ΔH (NSR)		
			0000. HRS 0000. MIN 00X.XX SEC XXXX.X NM XXXX.X NM

(P32) NORMAL CORRECTIVE MANEUVER #2 (NC2)

APOLLO-SOYUZ TEST PROJECT (ASTP)
OPERATIONS HANDBOOK

STA/T STEP	PROCEDURE	PANEL	REMARKS
CP	Accept Rcd data PRO Reject Key V22E, or V23E Load desired data	2,140	
7	FL V06 N37 GETI (TPI)	OOOX. HRS OOOX. MIN OXX.XX SEC	
	Accept Rcd GETI (TPI) PRO Reject Key V25E Load desired GETI (TPI)		
8	FL V16 N45 (mvr data) Marks	XXBXX MKS	Number of marks processed by R22. Two most significant digits display VHF ranging marks. Two least significant digits display optics marks [either SXT or backup optics (COAS) marks]. (If V87E, VHF marks accumulated automatically.) Optics marks may be taken anytime P20 operating.
	TF GETI (NC2)	XXBXX MIN-SEC	Time from NC2 ignition. Maximum reading 59B59. -, before; +, after.
	MGA	-0000X	-00001 for other than final pass. -00002 for final pass (and IMU not aligned).
	or IMU aligned	+XXX.XX DEG	Middle gimbal angle (yaw): +XXX.XX DEG for final pass and IMU aligned (if +X axis aligned to initial thrust direction).

(P32) NORMAL CORRECTIVE MANEUVER #2 (NC2)

11.2.2

NORMAL BACKUP

APOLLO-SOYUZ TEST PROJECT (ASTP)
OPERATIONS HANDBOOK

STA/T STEP	PROCEDURE	PANEL	REMARKS
CP	<p>To continue mark process Key V32E, go to 9</p> <p>or To terminate mark process & do final pass PRO, go to 9</p> <p>Poss FL V05 N09 00600 failure in phase match iterations 00601 failure in NCC height mnvr iterations 00602 failure in outer (phase) loop iterations 00603 failure in QRDTP1 iterations</p> <p>Key V32E Return to 5</p> <p>or PRO If 00600, 00601, or 00603 Go to 10</p> <p>or After final pass PRO, go to 11</p>	2,140	

(P32) NORMAL CORRECTIVE MANEUVER #2 (NC2)

APOLLO-SOYUZ TEST PROJECT (ASTP)
OPERATIONS HANDBOOK

STA/T STEP	PROCEDURE	PANEL	REMARKS
CP 9	FL V06 N84 ΔV (NCC) ΔH (NCC) ΔV (NSR) Rcd data PRO	2,140 XXXX.X FPS XXXX.X NM XXXX.X FPS	
10	FL V06 N81 VGX, Y, Z (NC2) Accept Rcd data PRO, return to 8 Reject Key V25E Load desired data	XXXX.X FPS	CMC calculated components of VG (in local vertical coordinates) for NC2. N81 values will be zero if PRO after alarms 00600, 00601, or 00603 (step 8).
11	FL V37 Key XXXE or If MINKEY, go to 12.2.1/12.2.2		For MINKEY, W-matrix reinitialization values are changed to 2K ft and 2 fps. If VG computed to be >10 fps, controller proceeds to P40 sequence. If VG <10 fps, controller proceeds to P41.

11.2.2

(P32) NORMAL CORRECTIVE MANEUVER #2 (NC2)

NORMAL BACKUP

APOLLO-SOYUZ TEST PROJECT (ASTP)
OPERATIONS HANDBOOK

STA/T STEP	PROCEDURE	PANEL	REMARKS
11.2.3	<p>(P33) <u>Normal Corrective Combination Maneuver (NCC)</u></p> <p>CMC - on (req), 6.1.3 ISS - on & orient known (desired), 8.1.3 & sec 13 DAP - load & activate (desired), 8.2.1</p> <p>1 If MINKEY auto call Go to 3</p> <p>CP or key V3TE 33E</p> <p>2 FL V50 N25 00017 (request MINKEY)</p>	2,140	<p>Calculates and displays parameters associated with NCC maneuver and AV burn. Successful completion dependent on prior completion of P32 or AH(NSR) stored (pad load).</p> <p>P33 can be selected manually (manual rendezvous sequence) or automatically by MINKEY controller (MINKEY rendezvous sequence).</p> <p>Keying V34E terminates P33 at any flashing display.</p> <p>Based on stored target parameters, the following parameters are computed and stored: AV(NCC) in N81 AV(NSR) in N82</p> <p>Computations include out-of-plane component at NSR.</p> <p>-Y dot (CSM) is written into R2 of N82.</p> <p>Refer to 9.2 for additional data on the MINKEY rendezvous sequence.</p> <p>Required for MINKEY and for meaningful MGA display during final N45 display (step 8).</p> <p>Required for auto maneuver to tracking attitude.</p> <p>If MINKEY initiated prior to P33, P33 automatically called by MINKEY controller at completion of N2 sequence.</p> <p>If IMU on and aligned, P20 automatically turned on. P33, however, can be selected without P20 in background.</p> <p>Occurs only if MINKEY sequence initiated at this point.</p>

(P33) NORMAL CORRECTIVE COMBINATION MANEUVER (NCC)

APOLLO-SOYUZ TEST PROJECT (ASTP)
OPERATIONS HANDBOOK

STA/T STEP	PROCEDURE	PANEL	REMARKS
CP	<p>PRO (MINKEY) ENTR (manual) Go to 3</p> <p>(R61, Tracking Attitude Routine)</p> <p>3 Maneuver</p> <p>If mnvr <10° SC cont - CMC/AUTO SC CONT - CMC CMC MODE - AUTO Go to 5</p> <p>If mnvr >10°, go to 4</p> <p>Poss PROG alarm Key V05 N09E (to verify alarm) 004G1 (MGA excessive)</p>	2,140	<p>PRO initiates MINKEY rendezvous sequence. ENTR allows manual sequencing. If not previously selected, P20 (option 4) would now be automatically selected and N78 (R3) would be loaded as determined by state of HDSUPFLG. Also refer to 9.2.1, note 9.</p> <p>Computes specified tracking attitude [computes required gimbal angles at tracking attitude (specified by N78) with present IMU orientation]. The CMC will compute and execute the appropriate maneuver (R61/R60).</p> <p>9.2.1, note 10.</p> <p>If maneuver <10°, R61 performs maneuver to tracking attitude.</p> <p>If maneuver >10° and V50N18 flag set, calls R60 (R60 performs maneuver). V50N18 flag set by V37 processing (except P00) and on initial entry to P20.</p> <p>If maneuver >10° and V50N18 flag not set, lights UPLINK ACTY light.</p> <p>P20 (option 4).</p>

11.2.3

(P33) NORMAL CORRECTIVE COMBINATION MANEUVER (NCC)

NORMAL BACKUP

APOLLO-SOYUZ TEST PROJECT (ASTP)
OPERATIONS HANDBOOK

STA/T STEP	PROCEDURE	PANEL	REMARKS
CP	<p>If MGA >75° CMC goes to att hold RHC - manually mnvr to sel track att Key V58E If mnvr <10°, to to 5 If mnvr ≥10°, go to 4</p> <p>or Align IMU to acceptable orient, sec 13 (R60, Attitude Maneuver Routine)</p> <p>(If UPLINK ACTY lt on Key V58E)</p>	2,140	<p>Prevents maneuver into gimbal lock.</p> <p>Sets V50N18 flag.</p>
AC	<p>4 Poss FL V50 N18 (auto mnvr request) (2 sec priority) If req angle change >10°</p> <p>R, P, Y XXX.XX DEG</p> <p>Accept SC cont - CMC/AUTO 1 SC CONT - CMC CMC MODE - AUTO PRO</p>		<p>Controller selects P20. Provides for maneuver (auto or manual) to attitude specified by option selected and N73 data. R60 called only if maneuver >10° as determined by R61. Otherwise maneuver performed by R61.</p> <p>Must key V58E in order to get R60 (V50 N18). R61 resets V50N18 flag at completion of first R61 cycle; therefore, V58E required to set flag to allow R60 if subsequent auto maneuver >10° required.</p> <p>DAP will point specified (N78) axis at Soyuz.</p> <p>Required gimbal angles.</p>
CP	<p>V06 N18 R, P, Y XXX.XX DEG Monitor auto mnvr on FDAI</p>	2,140	<p>This may be performed second time as attitude trim. Priority display. At completion of maneuver, display will revert to FL V50 N18 (non-MINKEY only).</p>

(P33) NORMAL CORRECTIVE COMBINATION MANEUVER (NCC)

APOLLO-SOYUZ TEST PROJECT (ASTP)
OPERATIONS HANDBOOK

STA/T STEP	PROCEDURE	PANEL	REMARKS
CP	Accept Rcd GETI (NSR) PRO Reject Key V25E Load desired GETI (NSR)	2,140	
7	FL V06 N37 GETI (TPI)	COXXX. HRS OOXXX. MIN OXX.XX SEC	
	Accept Rcd GETI (TPI) PRO Reject Key V25E Load desired GETI (TPI)		
8	FL V16 N45 Marks	XXBXX MKS	Number of marks processed by R22. Two most significant digits display VHF ranging marks. Two least significant digits display optics marks [either SXT or backup optics (COAS) marks]. (if V87E, VHF marks accumulated automatically.) Optics marks may be taken anytime P20 operating.
	TF GETI (NCC)	XXBXX MIN-S/C	Time from NCC ignition. Maximum reading 59B59. -, before; +, after.
	MGA	-0000X	-00001 for other than final pass. -00002 for final pass (and IMJ not aligned).
	or IMU aligned	+XXX.XX DEG	Middle gimbal angle (yaw): +XXX.XX DEG for final pass and IMU aligned (if +X axis aligned to initial thrust direction).

(P33) NORMAL CORRECTIVE COMBINATION MANEUVER (NCC)

APOLLO-SOYUZ TEST PROJECT (ASTP)
OPERATIONS HANDBOOK

STA T STEP	PROCEDURE	PANEL	REMARKS
CP	<p>To continue mark process Key V32E, go to 9</p> <p>or To terminate mark process & do final pass PRO, go to 9</p> <p>Poss FL V05 N09 00603 failure in QRDTP1 iterations PRO, go to 10</p> <p>or Key V32E, return to 5</p> <p>or After final pass PRO, go to 11</p> <p>9 FL V06 N82 AVX, Y, Z (NSR) XXXX.X FPS</p> <p>Rcd data PRO</p> <p>10 FL V06 N81 VGX, Y, Z (NCC) XXXX.X FPS</p> <p>Accept Rcd data PRO, return to 8</p> <p>Reject Key V25E Load desired data</p>	2,140	<p>To adjust input parameters.</p> <p>CMC calculated components of VG (in local vertical coordinates) for NSR. CMC automatically incorporates the negative of the computed Y dot (CSM) into R2 of N82. Used for nulling out-of-plane component (Y dot) at appropriate time.</p>

11.2.3

(P33) NORMAL CORRECTIVE COMBINATION MANEUVER (NCC)

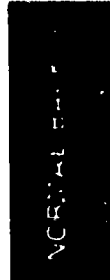

APOLLO-SOYUZ TEST PROJECT (ASTP)
OPERATIONS HANDBOOK

STA/T STEP	PROCEDURE	PANEL	REMARKS
CP 11 FL V37 Key XXE	or If MINKEY, go to 12.2.1/12.2.2	2,140	For MINKEY, W-matrix reinitialization values are changed to 2K ft and 2 fps. If VG computed to be >10 fps, controller proceeds to P40 sequence. If VG <10 fps, controller proceeds to P41.

(P33) NORMAL CORRECTIVE COMBINATION MANEUVER (NCC)

APOLLO-SOYUZ TEST PROJECT (ASTP)
OPERATIONS HANDBOOK

STA/T STEP	PROCEDURE	PANEL	REMARKS
11.2.4	(P34) Normal Slow Rate Manueuver (NSR)		Calculates and displays parameters associated with NSR manueuver and AV burn. Successful completion dependent on prior completion of P33 (NCC).
	CMC - on (req), 8.1.3 ISS - on & orient known (desired), 8.1.3 & sec 13		P34 can be selected manually (manual rendezvous sequence) or automatically by MINKEY controller (MINKEY rendezvous sequence).
	DAP - load & activate (desired), 8.2.1		Keying V34E terminates P34 at any flashing display.
	1 If MINKEY auto call Go to 3		Refer to 9.2 for additional data on the MINKEY rendezvous sequence.
	CP or key V37L 34E	2,140	Required for MINKEY and for meaningful MGA display during final M45 display (step 6).
	2 FL V50 M25 00017 (request MINKEY)		Required for auto manueuver to tracking attitude.
	PRO (MINKEY) EWTR (manual) Go to 3		If MINKEY initiated prior to P34, P34 automatically called by MINKEY controller at completion of last burn sequence.
			If IMU on and aligned, P20 automatically turned on. P34, however, can be selected without P20 in background.
			Occurs only if MINKEY sequence initiated at this point.
			PRO initiates MINKEY rendezvous sequence. EWTR allows manual sequencing. If not previously selected, P20 (option 4) would now be automatically selected and M78 (R3) would be loaded as determined by state of HDSUPFLG. Also refer to 9.2.1, note 9.

(P34) NORMAL SLOW RATE MANUEUVER (NSR)

11.2.4

NORMAL BACKUP

APOLLO-SOYUZ TEST PROJECT (ASTP)
OPERATIONS HANDBOOK

STA/T STEP	PROCEDURE	PANEL	REMARKS
3	<p>Maneuver</p> <p>(R61, Tracking Attitude Routine)</p>		<p>Computes specified tracking attitude [computes required gimbal angles at tracking attitude (specified by N78) with present IMU orientation]. The CMC will compute and execute the appropriate maneuver (R61/R60).</p>
CP	<p>If mnvr <10°</p> <p>SC cont - CMC/AUTO</p> <p>SC CONT - CMC</p> <p>CMC MODE - AUTO</p> <p>Go to 5</p> <p>If mnvr >10°, go to 4</p> <p>Poss PROG alarm</p> <p>Key V05 N09E (to verify alarm)</p> <p>00401 (MGA excessive)</p> <p>If MGA >75°</p> <p>CMC goes to att hold</p> <p>RHC - manually mnvr to sel track att</p> <p>Key V58E</p> <p>If mnvr <10°, go to 5</p> <p>If mnvr >10°, go to 4</p> <p>or Align IMU to acceptable orient, sec 13</p>	<p>2,140</p>	<p>9.2.1, note 10.</p> <p>If maneuver <10°, R61 performs maneuver to tracking attitude.</p> <p>If maneuver ≥10° and V50N18 flag set, calls R60 (R60 performs maneuver). V50N18 flag set by V37 processing (except P00) and on initial entry to P20.</p> <p>If maneuver >10° and V50N18 flag not set, lights UPLINK ACTY light.</p> <p>P20 (option 4).</p> <p>Prevents maneuver into gimbal lock.</p> <p>Sets V50N18 flag.</p>

(P34) NORMAL SLOW RATE MANEUVER (NSR)

APOLLO-SOYUZ TEST PROJECT (ASTP)
OPERATIONS HANDBOOK

STA/T STEP	PROCEDURE	PANEL	REMARKS
CP	(R60, Attitude Maneuver Routine) (If UPLINK ACTY 1t on Key V58E)	2,140	Controller selects P20. Provides for maneuver (auto or manual) to attitude specified by option selected and N78 data. R60 called only if maneuver >10° as determined by R61. Otherwise maneuver performed by R61. Must key V58E in order to get R60 (V50 N18). R61 resets V50N18 flag at completion of first R61 cycle; therefore, V58E required to set flag to allow R60 if subsequent auto maneuver >10° required.
4	Poss FL V50 N18 (auto mnvr request) (2 sec priority) If req angle change >10°		DAP will point specified (N78) axis at Soyuz.
AC	R, P, Y Accept SC cont - CMC/AUTO SC CONT - CMC CMC MODE - AUTO PRO	XXX.XX DEG 1	Required gimbals angles.
CP	V06 N18 R, P, Y Monitor auto mnvr on FDAI	2,140	This may be performed second time as attitude trim. Priority display. At completion of maneuver, display will revert to FL V50 N18 (non-MINKEY only).

11.2.4

(P34) NORMAL SLOW RATE MANEUVER (NSR)

NORMAL BACKUP

APOLLO-SOYUZ TEST PROJECT (ASTP)
OPERATIONS HANDBOOK

STA/T STEP	PROCEDURE	PANEL	REMARKS
CP	Reject Key V62E RHC - null FDAI error needles Recycle 4	2,140	Provides reference for manual maneuver.
AC	or SC CONT - SCS (or CMC mode # auto)	1	To update display without performing maneuver.
CP	PRO Recycle 4 When att satisfactory ENTR, go to 5	2,140	Terminates Attitude Maneuver Routine, R60. (Routine R61 will continue to compute and maintain selected attitude (option) as long as SC control CMC/AUTO and RHC not moved out of detent.) UPLINK ACTY light will be lit if V50N18 flag not set and tracking error, as determined by R61 ≥ 10 degrees. At this point, SXT marks can be taken. [For mark procedure, refer to (P20) 10.2.1, step 11]. If VHF ranging enabled (V87E) VHF marks automatic. Navigation automatic until final computation request.
5	FL V06 N13 GETI (NSR)		
	OOXX. HRS OOXX. MIN OXX.XX SEC		
	Accept Rcd GETI (NSR) PRO		
	Reject Key V25E Load desired GETI (NSR)		

(P34) NORMAL SLOW RATE MANEUVER (NSR)

APOLLO-SOYUZ TEST PROJECT (ASTP)
OPERATIONS HANDBOOK

STA/T STEP	PROCEDURE	PANEL	REMARKS
CP 6	FL V16 N45 Marks	2,140	Number of marks processed by R22. Two most significant digits display VHF ranging marks. Two least significant digits display optics marks [either SXT or backup optics (COAS) marks]. (If V87E, VHF marks accumulated automatically.) Optics marks may be taken anytime P20 operating.
	TF GETI (NSR)	XXBXX MIN-SEC	Time from NSR ignition. Maximum reading 59B59. -, before; +, after.
	MGA	-0000X	-00001 for other than final pass. -00002 for final pass (and IMU not aligned).
	or IMU aligned	+XXX.XX DEG	Middle gimbal angle (yaw): +XXX.XX DEG for final pass and IMU aligned (if +X axis aligned to initial thrust direction).
	To continue mark process Key V32E, go 7		
	or To terminate mark process & do final pass PRO, go to 7		
	Poss FL V05 N09 00611 No GETI for given E PRO, go to 7		
	or Key V32E, return to 5		
	or After final pass PRO, go to 9		

11.2.4

(P34) NORMAL SLOW RATE MANEUVER (NSR)

NORMAL BACK

APOLLO-SOYUZ TEST PROJECT (ASTP)
OPERATIONS HANDBOOK

STA/T STEP	PROCEDURE	PANEL	REMARKS
CP 7	FL V06 N75 Δ alt (NSR) AT (TPI -NSR)	2,140 XXXX.X JM XXBXX MIN-SEC	Maximum reading (displayed) in R2 and R3 is 59B59. Only minutes and seconds displayed although time computation done in hours, minutes, and seconds.
	AT (TPI -nom TPI)	XXBXX MIN-SEC	TPI computed minus input TPI time (N37). GETI (TPI) available via V06 N37E.
	Rcd values PRO		
5	FL V06 N81 VGX, Y, Z (NSR)	XXXX.X FPS	CMC calculated components of VG (in local vertical coordinates) for NSR. CMC automatically incorporates the negative of the computed Y dot (CSM) out-of-plane component (Y dot) at appropriate time.
	Accept Rcd data PRO, return to 6		
	Reject Key V25E Load desired data		
	If desired Key N90E		
	FL V06 N90 Y (CSM)	XXX.XX NM	
	Y dot (CSM)	XXXX.X FPS	
	Y dot (Soyuz)	XXXX.X FPS	
	Rcd data KEY REL		

(P34) NORMAL SLOW RATE MANEUVER (NSR)

APOLLO-SOYUZ TEST PROJECT (ASTP)
OPERATIONS HANDBOOK

STA/T STEP	PROCEDURE	PANEL	REMARKS
CP 9 FL V37 Key XXE	or If MINKEY, to to 12.2.1/12.2.2	2,140	For MINKEY, W-matrix reinitialization values are changed to 2K ft and 2 fps. If VG computed to be >10 fps, controller proceeds to P40 sequence. If $\overline{VG} < 10$ fps, controller proceeds to P41.

(P34) NORMAL SLOW RATE MANEUVER (NSR)

11.2.4

NORMAL BACKUP

APOLLO-SOYUZ TEST PROJECT (ASTP)
OPERATIONS HANDBOOK

STA/T STEP	PROCEDURE	PANEL	REMARKS
11.2.5	(P35) Transfer Phase Initiation (TPI)		<p>P35 Transfer Phase Initiation calculates required ΔV and other initial conditions required by CMC for CSM execution of TPI maneuver, given:</p> <ul style="list-style-type: none"> a. Time of ignition, nominal GETI (TPI), or elevation angle (E) of CSM-to-Soyuz LOS at GETI (TPI). b. Central angle of transfer (CENTANG) of passive vehicle from GETI (TPI) to time of intercept. CENTANG = 130° (fixed memory). c. Calculates GETI (TPI) given E, or E given nominal GETI (TPI). <p>P35 can be selected manually (manual rendezvous sequence) or automatically by MINKEY controller (MINKEY rendezvous sequence).</p> <p>Keying V34E terminates P35 at any flashing display.</p> <p>Refer to 9.2 for additional data on the MINKEY rendezvous sequence.</p> <p>Required for MINKEY and for meaningful MGA display during final N45 display (step 7).</p> <p>Required for auto maneuver to tracking attitude.</p> <p>If MINKEY initiated prior to P35, P35 automatically called by MINKEY controller at completion of NSR sequence.</p> <p>If IMU on and aligned, P20 automatically turned on. P35, however, can be selected without P20 in background.</p>
	<p>CMC - on (req), 8.1.3 ISS - on & orient known (desired), 8.1.3 & sec 13</p> <p>DAP - load & activate (desired), 8.2.1</p> <p>1 If MINKEY auto call Go to 3</p> <p>CP or Key V37E 35E</p>	2,140	

(P35) TRANSFER PHASE INITIATION (TPI)

APOLLO-SOYUZ TEST PROJECT (ASTP)
OPERATIONS HANDBOOK

STA/T STEP	PROCEDURE	PANEL	REMARKS
CP 2	FL V50 N25 00017 (request MINKEY) PRO (MINKEY) ENTR (manual)	2,140	Occurs only if MINKEY sequence initiated at this point. PRO initiates MINKEY rendezvous sequence. ENTR allows manual sequencing. If not previously selected, P20 (option 4) would now be automatically selected and N78 (R3) would be loaded as determined by state of HDSUPFLG. Also refer to 9.2.1, note 9.
3	Maneuver (R61, Tracking Attitude Routine)		Computes specified tracking attitude [computes required gimbal angles at tracking attitude (specified by N78) with present IMU orientation]. The CMC will compute and execute the appropriate maneuver (R61/R60). 9.2.1, note 10. If maneuver <10°, R61 performs maneuver to tracking attitude. If maneuver >10° and V50N18 flag set, calls R60 (R60 performs maneuver). V50N18 flag set by V37 processing (except P00) and on initial entry to P20. If maneuver >10° and V50N18 flag not set, lights UPLINK ACTY Light. P20 (option 4).

11.2.5

(P35) TRANSFER PHASE INITIATION (TPI)



APOLLO-SOYUZ TEST PROJECT (ASTP)
OPERATIONS HANDBOOK

STA/T STEP	PROCEDURE	PANEL	REMARKS
CP	<p>If MGA > 75° CMC goes to att hold RHC - manually mnvr to sel track att Key V58E If mnvr < 10°, go to 5 If mnvr > 10°, go to 4 or Align IMU to acceptable orient, sec 13 (R60, Attitude Maneuver Routine)</p> <p>(If UPLINK ACTY lt on) Key V58E</p> <p>4 Poss FL V50 N18 (auto mnvr request) (2 sec priority) If req angle change ≥ 10° R, P; Y XXX.XX DEG</p>	2,140	<p>Prevents maneuver into gimbal lock.</p> <p>Sets V50N18 flag.</p> <p>Controller selects P20. Provides for maneuver (auto or manual) to attitude specified by option selected and N78 data. R60 called only if maneuver > 10° as determined by R61. Otherwise maneuver performed by R61.</p> <p>Must key V58E in order to get R60 (V50 N18). R61 resets V50N18 flag at completion of first R61 cycle; therefore, V58E required to set flag to allow R60 if subsequent auto maneuver > 10° required.</p> <p>DAP will point specified (N78) axis at Soyuz.</p> <p>Required gimbal angles.</p>
AC	<p>Accept SC cont - CMC/AUTO SC CONT - CMC CMC MODE - AUTO PRO</p>	1	<p>This may be performed second time as attitude trim.</p> <p>Priority display. At completion of maneuver, display will revert to FL V50 N18 (non-MINKEY only).</p>
CP	<p>V06 N18 R, P, Y XXX.XX DEG Monitor auto mnvr on FDAI</p>	2,140	

(P35) TRANSFER PHASE INITIATION (TPI)

APOLLO-SOYUZ TEST PROJECT (ASTP)
OPERATIONS HANDBOOK

STA/T STEP	PROCEDURE	PANEL	REMARKS
CP	Reject Key V62E RHC - null FDAI error needles Recycle 4 or SC CONT - SCS (or CMC mode ≠ auto) PRO Recycle 4 When att satisfactory ENTR, go to 5	2,140 1 2,140	Provides reference for manual maneuver. To update display without performing maneuver. Terminate Attitude Maneuver Routine, R60. (Routine R61 will continue to compute and maintain selected attitude (option) as long as SC control CMC/AUTO and RHC not moved out of detent.) UPLINK ACTY light will be lit if V50N18 flag not set and tracking error, as determined by R61, >10 degrees. At this point, SXT marks can be taken. [For mark procedure, refer to (P20) 10.2.1, step 11]. If VHF ranging enabled (V87E), VHF marks automatic. Navigation automatic until final computation request.
5	FL V06 N37 GETI (TPI) Accept Rcd GETI (TPI) PRO Reject Key V25E Load desired GETI (TPI)	OXXX. HRS OOOX. MIN OXX.XX SEC	Load desired GETI (TPI) if CMC computation of E desired. For a specified value of E and CMC computation of GETI (TPI), load an initial value of GETI (TPI). Loaded value should be within 30 minutes of actual.

11.2.5

(P35) TRANSFER PHASE INITIATION (TPI)

NORMAL BACKUP

APOLLO-SOYUZ TEST PROJECT (ASTP)
OPERATIONS HANDBOOK

STA/T STEP	PROCEDURE	PANEL	REMARKS
CP 6	FL V06 N55 NN E Accept Rcd E PRO Reject Key V24E Load desired data	2,140 0000X. XXX.XX DEG	Integration method and number of precision offset computations desired. NN initially +00000. Elevation angle (pad loaded erasable). Load desired NN in R1: 0, conic integration; X, precision integration with (X) target offsets. Desired E in R2, CMC computes GETI (TPI). +00000 in R2, CMC computes E. After recycle from step 11, V06 N59 may be keyed for required impulsive ΔV components in an orthogonal coordinate system oriented along CSM to Soyuz LOS. (For complete definition, refer to GSOP section 5.4.6 of R693.) Number of marks processed by R22. Two most significant digits display VHF ranging marks. Two least significant digits display optics marks [either SXT or backup optics (COAS) marks]. (If V87E, VHF marks accumulated automatically.) Optics marks may be taken anytime P20 operating. Time from TPI ignition. Maximum reading 59B59. -, before; +, after. -00001 for other than final pass. -00002 for final pass (and IMU not aligned). Middle gimbal angle (yaw): +XXX.XX DEG for final pass and IMU aligned (if +X axis aligned to initial thrust direction).
7	FL V16 N45 Marks TF GETI (TPI) MGA or IMU aligned	 XXBXX MKS XXBXX MIN-SEC -0000X +XXX.XX DEG	

(P35) TRANSFER PHASE INITIATION (TPI)

APOLLO-SOYUZ TEST PROJECT (ASTP)
OPERATIONS HANDBOOK

STA/T STEP	PROCEDURE	PANEL	REMARKS
CP	<p>To continue mark process Key V32E If E = 0, go to 8 If E ≠ 0, go to 9</p> <p>or To terminate mark process & do final pass PRO If E = 0, go to 8 If E ≠ 0, go to 9</p> <p>or After final pass PRO, go to 12</p> <p>8 If +00000 specified for E (CMC computes E) FL V06 N55 NN 0000X.</p> <p>E XXX.XX DEG</p> <p>Rcd E PRO, go to 10</p> <p>9 If E specified (CMC computes GETI) Poss FL V05 N09 00611 (no GETI for given E) PRO, return to 5 (adj input parameters)</p>	2,140	<p>Integration method and number of precision offset computations desired.</p> <p>CMC computed E based on N37 GETI (TPI).</p>

11.2.5

(P35) TRANSFER PHASE INITIATION (TPI)

NORMAL BACKUP

SM2A-03-SKYLAB-(2)
SKYLAB OPERATIONS HANDBOOK

STA/T STEP	PROCEDURE	PANEL	REMARKS
CP	<p>FL V06 N37 GETI (TPI)</p> <p>OOXX. HRS OOXX. MIN OXX.XX SEC</p> <p>Rcd GETI (TPI)</p> <p>PRO, go to 10</p> <p>or Key V25E Load desired GETI (TPI)</p> <p>or PRO, go to 10 If MINKEY & final pass PRO, return to 8</p> <p>10 FL V06 N58 ΔV (TPI) XXXX.X FPS ΔV (TPF) XXXX.X FPS ΔT (TPI -nom TPI) XXBX MIN-SEC</p> <p>Rcd data PRO</p>	2,140	<p>To accept computed GETI (TPI).</p> <p>Reject computed GETI (TPI), specify GETI (TPI) and allow CMC to compute E.</p> <p>TPI computed minus input TPI time (N37).</p>

(P35) TRANSFER PHASE INITIATION (TPI)

APOLLO-SOYUZ TEST PROJECT (ASTP)
OPERATIONS HANDBOOK

STA/T STEP	PROCEDURE	PANEL	REMARKS
CP 11	FL V06 N81 VGX, Y, Z (TPI) XXXX.X FPS Accept Rcd data PRO, return to 7 Reject Key V25E Load desired data	2,140	CMC calculated components of VG (in local vertical coordinates) for TPI. To modify VG (lcl vert) to correct for out of planeness, key V90E (R36). Use data obtained from R36 to determine desired VG (lcl vert). For MINKEY, W-matrix reinitialization values are changed to 2K ft and 2 fps. If VG computed to be >10 fps, controller proceeds to P40 sequence. If VG <10 fps, controller proceeds to P41.
12	FL V37 Key XOE or If MINKEY, go to 12.2.1/12.2.2		

11.2.5

(P35) TRANSFER PHASE INITIATION (TPI)

NORMAL BACKUP

APOLLO-SOYUZ TEST PROJECT (ASTP)
OPERATIONS HANDBOOK

STA/T STEP	PROCEDURE	PANEL	REMARKS
11.2.6	(P36) Transfer Phase Midcourse (TPM)		
	CMC - on (req), 8.1.3 ISS - on & orient known (desired), 8.1.3 & sec 13		P36 Transfer Phase Midcourse calculates required ΔV and other initial conditions required by CMC for execution of next midcourse correction of transfer phase. Successful completion dependent on prior completion of P35 (TPI).
	DAP - load & activate (desired), 8.2.1		P36 can be selected manually (manual rendezvous sequence) or automatically by MINKEY controller (MINKEY rendezvous sequence).
1	If MINKEY auto call Go to 3		Keying V34E terminates P36 at any flashing display.
			Refer to 9.2 for additional data on the MINKEY rendezvous sequence.
			Required for MINKEY and for meaningful MGA display during final M45 display (step 5).
			Required for auto maneuver to tracking attitude.
			If MINKEY initiated prior to P36, P36 automatically called by MINKEY controller at completion of TPI sequence, and again after completion of first midcourse (TPM) burn.
SPT or	Key V37E 36E	2,140	If IMU on and aligned, P20 automatically turned on. P36, however, can be selected without P20 in background.
2	FL V50 M25 00017 (request MINKEY)		Occurs only if MINKEY sequence initiated at this point.

(P36) TRANSFER PHASE MIDCOURSE (TPM)

APOLLO-SOYUZ TEST PROJECT (ASTP)
OPERATIONS HANDBOOK

STA/T STEP	PROCEDURE	PANEL	REMARKS
CP	PRO (MINKEY) ENTR (manual) Go to 3 (R61, Tracking Attitude Routine)	2,140	PRO initiates MINKEY rendezvous sequence. ENTR allows manual sequencing. If not previously selected, P20 (option 4) would now be automatically selected and N78 (R3) would be loaded as determined by status of HDSUPFLG. Also refer to 9.2.1, note 9.
3	Maneuver If mnvr <10° SC cont - CMC/AUTO SC CONT - CMC CMC MODE - AUTO Go to 5		Computes specified tracking attitude [computes required gimbal angles at tracking attitude (specified by N78) with present IMU orientation]. The CMC will compute and execute the appropriate maneuver (R61/R60).
			9.2.1, note 10.
			If maneuver <10°, R61 performs maneuver to tracking attitude.
			If maneuver >10° and V50N18 flag set, calls R60 (R60 performs maneuver). V50N18 flag set by V37 processing (except P00) and on initial entry to P20.
	Poss PROG alarm Key V05 N09E (to verify alarm) 00401 (MCA excessive)		If maneuver >10° and V50N18 flag not set, lights UPLINK ACTY light. P20 (option 4).

11.2.6

(P36) TRANSFER PHASE MIDCOURSE (TPM)



APOLLO-SOYUZ TEST PROJECT (ASTP)
OPERATIONS HANDBOOK

STA/T STEP	PROCEDURE	PANEL	REMARKS
AC	Accept SC cont - CMC/AUTO	1	This may be performed second time as attitude trim. Priority display. At completion of maneuver, display will revert to FL V50 N18 (non-MINKEY only). Provides reference for manual maneuver.
CP	SC CONT - CMC CMC MODE - AUTO PRO V06 N18 R, P, Y XXX.XX DEG Monitor auto mnvr on FDAI Key V62E Reject RHC - null FDAI error needles Recycle 4	2,140	
AC	or SC CONT - SCS (or CMC mode ≠ auto)	1	To update display without performing maneuver. Terminates Attitude Maneuver Routine, R60. (Routine R61 will continue to compute and maintain selected attitude (option) as long as SC control CMC/AUTO and RHC not moved out of detent.) UPLINK ACTY light will be lit if V50N18 flag not set and tracking error, as determined by R61, >10 degrees. At this point, SXT marks can be taken. [For mark procedure, refer to (P20) 10.2.1, step 11]. If VHF ranging enabled (V87E) VHF marks automatic. Navigation automatic until final computation request.
CP	PRO Recycle 4 When att satisfactory ENTR, go to 5	2,140	

11.2.6

(P36) TRANSFER PHASE MIDCOURSE (TPM)

NORMAL BACKUP

APOLLO-SOYUZ TEST PROJECT (ASTP)
OPERATIONS HANDBOOK

STA/T STEP	PROCEDURE	PANEL	REMARKS
CP 5 FL V16 J45	Marks XXBXX MKS	2,140	Number of marks processed by R22. Two most significant digits display VHF ranging marks. Two least significant digits display optics marks [either SXT or backup (COAS) marks]. (If V67E, VHF marks accumulated automatically.) Optics marks may be taken anytime P20 operating.
TF GETI (TPM)	XXBXX MIN-SEC		(-): Time from previous burn (TPI or TPM 1) before final pass. (+): Time from TPM ignition after final pass. Maximum reading 59B59.
MGA	-0000X		-00001 for other than final pass. -00002 for final pass (and IMU not aligned).
or IMU aligned	+XXX.XX DEG		Middle gimbal angle (yaw): +XXX.XX DEG for final pass and IMU aligned (if +X axis aligned to initial thrust direction).
or To continue mark process key V32E, go to 6			
or To terminate mark process & do final pass PRO, go to 6			
or After final pass PRO, go to 7			

(P36) TRANSFER PHASE MIDCOURSE (TPM)

APOLLO-SOYUZ TEST PROJECT (ASTP)
OPERATIONS HANDBOOK

STA/T STEP	PROCEDURE	PANEL	REMARKS
CP 6	FL V06 N59 AVX, Y, Z (LOS) XXXX.X FPS Accept Rcd data PRO, return to 5 Reject Key V25E Load desired data	2,140	CMC calculated components of AV for TPM oriented along CSM to Soyuz LOS.
7	FL V37 Key XXE or If MINKEY, go to 12.2.1/12.2.2		For MINKEY, W-matrix reinitialization values are changed to 2K ft and 2 fps. If VG computed to be >10 fps, controller proceeds to P40 sequence. If VG <10 fps, controller proceeds to P41.

(P36) TRANSFER PHASE MIDCOURSE (TPM)

11.2.6

NORMAL/BACKUP

APOLLO-SOYUZ TEST PROJECT (ASTP)
OPERATIONS HANDBOOK

STA/T STEP	PROCEDURE	PANEL	REMARKS
11.2.7	(P37) Transfer Phase Final (TPF)		Displays CMC calculated rendezvous parameters (range, range rate, and theta). Initiates automatic maneuver to X-axis tracking attitude.
	CMC - on (req), 8.1.3		P37 can be selected manually (manual rendezvous sequence) or automatically by MINKEY controller (MINKEY rendezvous sequence).
	ISS - on & orient known (req), 8.1.3 & sec 13		Keying V34E terminates P37 at any flashing display.
	DAP - load & activate (desired), 8.2.1		Refer to 9.2 for additional data on the MINKEY rendezvous sequence.
	1 MINKEY auto call		Required for auto maneuver to X-axis tracking attitude.
CP or	Key V37E 37E	2,140	CMC executes V83 (R31). R1 and R2 of N78 (P20) set to zero prior to initiating R31.
	2 FL V50 N25		If IMU on and aligned, P20 automatically turned on. P37, however, can be selected without P20 in background.
	00017 (request MINKEY)		Occurs only if MINKEY sequence initiated at this point.
	PRO (MINKEY)		PRO initiates MINKEY rendezvous sequence. ENTR allows manual sequencing. If not previously selected, P20 (option 4) would now be automatically selected and N78 (R3) would be loaded as determined by state of HDSUPPLG. Also refer to 9.2.1, note 9.
	ENTR (manual)		

(P37 TRANSFER PHASE FINAL (TPF))

APOLLO-SOYUZ TEST PROJECT (ASTP)
OPERATIONS HANDBOOK

STA/T STEP	PROCEDURE	PANEL	REMARKS
CP	(R61, Tracking Attitude Routine)	2,140	Computes specified tracking attitude [computes required gimbal angles at tracking attitude (specified by N78) with present IMU orientation]. The CMC will compute and execute the appropriate maneuver (R61/R60).
3	Maneuver		9.2.1.1, note 10.
AC	If mnvr <10° SC cont - CMC/AUTO SC CONT - CMC CMC MODE - AUTO Go to 5	1	If maneuver <10°, R61 performs maneuver to specified (N78) tracking attitude.
	If mnvr >10°, go to 4		If maneuver >10° and V50N18 flag set, calls R60 (R60 performs maneuver to specified (N78) tracking attitude). V50N18 flag set by V37 processing (except P00) and on initial entry to P20.
CP	Poss PROG alarm Key V05 N09E (to verify alarm) 00401 (MGA excessive)	2,140	If maneuver >10° and V50N18 flag not set, lights UPLINK ACTY light. P20 (option 4).
AC	If MGA >75° CMC goes to att hold		
CP	RHC - manually mnvr to sel track att Key V58E If mnvr <10°, go to 5 If mnvr >10°, go to 4		Prevents maneuver into gimbal lock.

11.2.7

(P37) TRANSFER PHASE FINAL (TPF)

NORMAL BACKUP

APOLLO-SOYUZ TEST PROJECT (ASTP)
OPERATIONS HANDBOOK

STA/T STEP	PROCEDURE	PANEL	REMARKS
CP	or Align IMU to acceptable orient, sec 13 (R60, Attitude Maneuver Routine) (If UPLINK ACTY Lt on Key V58E)		Controller selects P20. Provides for maneuver (auto or manual) to attitude specified by option selected and N78 data. R60 called only if maneuver $\geq 10^\circ$ as determined by R61. Otherwise maneuver performed by R61.
AC	4 Poss FL V50 N18 (auto mnvr request) (2 sec priority) If req pointing angle change $> 10^\circ$	2,140	Must key V58E in order to get R60 (V50 N18). R61 resets V50N18 flag at completion of first P61 cycle; therefore, V58E required to set flag to allow R60 if subsequent auto maneuver $\geq 10^\circ$ required.
AC	F, P, Y XXX.XX DEG Accept SC cont - CMC/AUTO SC CONT - CMC CMC MODE - AUTO PRO V06 N18 R, P, Y XXX.XX DEG Monitor auto mnvr on FDAI Key V62E Reject RHC - null FDAI error needles Recycle 4	1	DAP will point specified (N78) axis at Soyuz. Required gimbal angles.
CP		2,140	This may be performed second time as attitude trim. Priority display. Provides reference for manual maneuver.
AC	or SC CONT - SCS (or CMC mode \neq auto) PRO Recycle 4	1	To update display without performing maneuver.
CP	Recycle 4	2,140	

(P37) TRANSFER PHASE FINAL (TPF)

APOLLO-SOYUZ TEST PROJECT (ASTP)
OPERATIONS HANDBOOK

STA/T STEP	PROCEDURE	PANEL	REMARKS
CP	When att satisfactory EMTR, go to 5	2,140	Terminates Attitude Maneuver Routine, R60. (Routine R61 will continue to compute and maintain selected attitude (option) as long as SC control CMC/AUTC and RHC not moved out of detent.) UPLINK ACTY light will be lit if V50N18 flag not set and gimbal angle error, as determined by R61, >10 degrees.
5	FL V16 N54		If another extended verb active. (Not expected on P37 call by MINKEY.)
R	Foss OPR ERR	XXX.XX NM	Display updated at 2-second intervals.
R dot		XXXX.X FPS	Range and range rate based on stored state vectors. Range and range rate may degrade considerably at ranges below ≈ 0.3 to 0.5 NM depending on marking schedules and resultant navigation accuracy.
Theta (incl horiz/CSM +X)		XXX.XX DEG	(-) range rate indicates closing. This calculation not sufficiently accurate for reliable terminal closing values. It should not be utilized without good visual cues.
PRO	If MINKEY, go to 8.1.7 Manual FL V37 Key XXE		Theta - Angle included between +Xsc axis and local horizontal. Angle in range 0° to 180° indicates +Xsc axis is above local horizontal plane. Total range: 0° to 360° . (P48) Rendezvous Thrust Monitor (final phase).

11.2.7

(P37) TRANSFER PHASE FINAL (TPF)

NORMAL/BACKUP

APOLLO-SOYUZ TEST PROJECT (ASTP)
OPERATIONS HANDBOOK

STA/T STEP	PROCEDURE	PANEL	REMARKS
11.2.0	(E3E) Normal Plane Change Targeting (NPC)		Computes and displays out-of-plane parameters required for execution of plane change maneuver, e.g., for one case of a non-coplanar condition, an antinode is established as a function of the NPC maneuver (P33). P38 then, targets a second nulling maneuver to be performed 90° later (at the node at the appropriate time), resulting in desired CSM, Soyuz, coplanar orbits.
	CNC - on (req), 8.1.3 ISC - on & orient known (desired), 8.1.3 & sec 13		P38 is called by manual selection only (V37E 38E). It is not called automatically by the MINKEY controller as part of the normal MINKEY rendezvous sequence. P30 on FL V50 N25 (00017) however, does provide MINKEY controller functions (P20, P52 call for gyro torquing, etc.) within the NPC sequence.
	DAP - load & activate (desired), 6.2.1		Keying V34E terminates P38 at any flashing display.
CP 1	Key V37E 38E	2,140	Refer to 9.2 for additional data on the MINKEY rendezvous sequence.
			Required for P38 MINKEY and for meaningful M3A display during final N45 display (step 7).
			Required for auto maneuver to tracking attitude.
			If IMU on and aligned, P20 automatically turned on. P38, however, may be selected without P20 in background.

(P38) NORMAL PLANE CHANGE TARGETING (NPC)

APOLLO-SOYUZ TEST PROJECT (ASTP)
OPERATIONS HANDBOOK

STA/T STEP	PROCEDURE	PANEL	REMARKS
CP 2	FL V50 N25 00017 (request MINKEY) PRO (MINKEY) ENTR (manual) Go to 3 (R61, Tracking Attitude Routine)	2,140	PRO initiates NPC MINKEY sequence. ENTR allows manual sequencing. If not previously selected, P20 (option 4) would now be automatically selected and N78 (R3) would be loaded as determined by state of HDSUPFLG. Also refer to 9.2.1, note 9. Computes specified tracking attitude [computes required gimbal angles at tracking attitude (specified by N78) with present IMU orientation]. The CMC will compute and execute appropriate maneuver (R61/R60). 9.2.1, note 10.
AC 3	Maneuver If mnvr <10° SC cont - CMC/AUTO SC CONT - CMC CMC MODE - AUTO Go to 5 If mnvr ≥10°, go to 4	1	If maneuver <10°, R61 performs maneuver to tracking attitude. If maneuver >10° and V50N18 flag set, calls R60 (R60 performs maneuver). V50N18 flag set by V37 processing (except P00) and on initial entry to P20. If maneuver >10° and V50N18 flag not set, lights UPLINK ACTY light. P20 (option 4).
CP	Poss PRG alarm Key V05 NC9E (to verify alarm) 00401 (MGA excessive)	2,140	

11.2.6

(P38) NORMAL PLANE CHANGE TARGETING (NPC)

NORMAL/BACKUP

APOLLO-SOYUZ TEST PROJECT (ASTP)
OPERATIONS HANDBOOK

STA/T STEP	PROCEDURE	PANEL	REMARKS
CP	<p>If MGA >75° CMC goes to att hold RHC - manually mnvr to sel track att Key V58E 2,140 If mnvr <10°, go to 5 If mnvr >10°, go to 4 or Align IMU to acceptable orient, sec 13 (R60, Attitude Maneuver Routine)</p> <p>(If UPLINK ACTY 1t on Key V58E)</p> <p>4 Poss FL V50 N18 (auto mnvr request) (2 sec priority) If req angle change >10°</p>		<p>Prevents maneuver into gimbal lock. Sets V50N18 flag.</p> <p>Controller selects P20. Provides for maneuver (auto or manual) to attitude specified by option selected and N78 data. R60 called only if maneuver >10° as determined by R61. Otherwise maneuver performed by R61.</p> <p>Must key V58E in order to get R60 (V50 N18). R61 resets V50N18 flag at completion of first R61 cycle; therefore, V58E required to set flag to allow R60 if subsequent auto maneuver >10° required.</p> <p>DAP will point specified (N78) axis at Soyuz.</p>
AC	<p>R, P, Y XXX.XX DEG</p> <p>Accept SC cont - CMC/AUTO 1 SC CONT - CMC CMC MODE - AUTO PRO</p>		<p>Required gimbal angles.</p>
CF	<p>V06 N18 R, P, Y XXX.XX DEG Monitor auto mnvr on FDAI</p>	2,140	<p>This may be performed second time as attitude trim. Priority display. At completion of maneuver, display will revert to FL V50 N18 (non-MINKEY only).</p>

(P38) NORMAL PLANE CHANGE TARGETING (NPC)

APOLLO-SOYUZ TEST PROJECT (ASTP)
OPERATIONS HANDBOOK

STA/T STEP	PROCEDURE	PANEL	REMARKS
CP	Reject Key V62E RHC - null FDAI error needles Recycle 4	2,140	Provides reference for manual maneuver.
AC	or SC CONT - SCS (or CMC mode ≠ auto)	1	To update display without performing maneuver.
CP	PRO Recycle 4 When att satisfactory ENTR, go to 5	2,140	Terminates Attitude Maneuver Routine, R60, (Routine R61 will continue to compute and maintain selected attitude (option) as long as SC control CMC/AUTO and RHC not moved out of detent.) UPLINK ACTY light will be lit if V50N18 flag not set and tracking error, as determined by R61, >10 degrees. At this point, SXT marks can be taken. [For mark procedure, refer to (P20) 10.2.1, step 11]. If VHF ranging enabled (V87E), VHF marks automatic. Navigation automatic until final computation request.
5	FL V06 N39 GETI (last mnvr) OOXX. HRS OOXX. MIN OXX.XX SEC		
	Accept Rcd GETI (last mnvr) PRO Reject Key V25E Load desired GETI (last mnvr)		

(P38) NORMAL PLANE CHANGE TARGETING (NCP)

11.2.8

NORMAL BACKUP

APOLLO-SOYUZ TEST PROJECT (ASTP)
OPERATIONS HANDBOOK

STA/T STEP	PROCEDURE	PANEL	REMARKS
CP 6	FL V06 N33 GETI (NPC)	2,140	Time 1/4 rev after time specified in N39.
	Rcd data PRO	OOXXX. HRS OOXXX. MIN OXX.XX SEC	
7	FL V16 N45 (mnvr data) Marks	XXBXX MKS	Number of marks processed by R22. Two most significant digits display VHF ranging marks. Two least significant digits display optics marks [either SXT or backup optics (COAS) marks]. (If V87E, VHF marks accumulated automatically). Optics marks may be taken anytime P20 operating.
	TF GETI (NPC)	XXBXX MIN-SEC	Time from NPC ignition. Maximum reading 59B59. -, before; +, after.
	MGA	-0000X	-00001 for other than final pass. -00002 final pass, IMU not aligned.
	or IMU aligned	+XXX.XX DEG	Middle gimbal angle (yaw): +XXX.XX DEG for final pass and IMU aligned (if +X axis aligned to initial thrust direction).
	To continue mark process Key V32E, go to 8		
	or To terminate mark process & do final pass PRO, go to 8		
	or After final pass PRO, go to 9		

(P38) NORMAL PLANE CHANGE TARGETING (NPC)

APOLLO-SOYUZ TEST PROJECT (ASTP)
OPERATIONS HANDBOOK

NORMAL BACKUP

STA/T STEP	PROCEDURE	PANEL	REMARKS
CP	or If MINKEY and If VG = 0 (bypass gyro torquing) If VG > 0, go to 13.1.3		Bypass Gyro torquing option in P52. Controller selects P52 for gyro torquing option. If gyros not torqued, P41 automatically selected. If gyros torqued, and VG computed to be ≥ 10 fps, controller proceeds to P40 sequence; if VG < 10 fps, controller proceeds to P41.
8	FL V06 N81 VGX, Y, Z (1cl vert) XXXX.X FPS	2,140	CMC calculated components of VG (in local vertical coordinates) for NPC. CMC automatically incorporates the negative of the computed Y dot (CSM) into R2 of N81 (R1 and R3 = 0). Used for nulling out-of-plane component (Y dot) at appropriate time.
	Accept Rcd data PRO, return to 7 Reject Key V22E Load desired data		
	If desired Key N90E FL V06 N90 (rndz out of plane param) Y (CSM) XXX.XX NM Y dot (CSM) XXXX.X FPS Y dot (Soyuz) XXXX.X FPS		
9	Rcd data KEY REL FL V37 Key XXE		

11.2.8 (P38) NORMAL PLANE CHANGE TARGETING (NPC)

APOLLO-SOYUZ TEST PROJECT (ASTP)
OPERATIONS HANDBOOK

STA/T STEP	PROCEDURE	PANEL	REMARKS
12.0	THRUSTING		For general G&C operating data, refer to operating notes, 6.1.
12.1	VEHICLE PREPARATION		
	(Proced not designated as "req" are optional)		
1	For orb change		
CP	Obtain update from STDN Gas Separator Cartridge Prep (req) Remove separator from water pistol & stow temporarily in LEB stowage bag Assure separator on food prep unit secured with bayonet locks Install outlet cap on food prep unit separator SPS and SM RCS Checks, 5.2.1 & 5.2.2 EPS DC & AC Checks, 5.3.2 & 5.3.3 Pres Suit Ckt & PGA Check at 5.0 psia, 5.4.9 (if req) C&WS Oper Check, 5.5.1 CMC Self Check, 8.1.8 DSKY Condition Light Check, 8.3.1 Dry tunnel		If necessary, absorb water with towel. Condensed moisture in tunnel rains on crew during thrusting.
	AV Test & Null Bias Check, 7.6.1		In-flight verification of X-axis accelerometer output, AV indicator, SPS THRUST light, and thrust cutoff relay in EMS.
AC	If preparing for NC2 rndz mnvr DIRECT O2 vlv - close (CW)	7	DIRECT O2 valve closed after minimum of 3 hours total operation from launch.

12.1

VEHICLE PREPARATION

NORMAL BACKUP

APOLLO-SOYUZ TEST PROJECT (ASTP)
OPERATIONS HANDBOOK

STA/T STEP	PROCEDURE	PANEL	REMARKS
AC	<p>For PSM activation SM RCS PSM He - OPEN PSM He tb - gray SM RCS QUAD PRPLNT (4) - CLOSE SM RCS PSM PRPLNT (4) - OPEN SM RCS QUAD PRPLNT tb (8) - bp SM RCS PSM PRPLNT tb (4) - gray SM RCS QUAD He (4) - CLOSE SM RCS QUAD He tb (4) - bp</p> <p>2 For deorbit Deorbit & Entry Veh Prep, 14.1 (req)</p>	2	<p>Nominal mission requires that PSM be activated after 50 lbs primary (quad) propellant has been expended. Provides adequate contingency blowdown capabilities and ensures sufficient RCS quad propellant for hybrid deorbit.</p>

VEHICLE PREPARATION

APOLLO-SOYUZ TEST PROJECT (ASTP)
OPERATIONS HANDBOOK

STA/T STEP	PROCEDURE	PANEL	REMARKS
12.2	G&N THRUSTING		
12.2.1	<u>(P40) G&N/SPS Thrusting</u>		<p>Computes preferred CSM attitude and IMU orientation for SPS thrusting maneuver.</p> <p>Calculates and displays gimbal angles which would result if present IMU orientation used for thrusting in preferred vehicle attitude (function of R60 computations). Crew then decides whether to thrust at present IMU orientation or to reorient IMU using P52/P54.</p> <p>Maneuvers CSM to thrusting attitude (R60).</p> <p>Control's GNCS during SPS thrust countdown, ignition, thrust, and thrust termination; and allows residual steering error trimming.</p> <p>P40 should not be performed in CSM-Soyuz docked configuration.</p> <p>G&C circuit breakers on all panels should be closed except as defined in Limited Use Controls, 6.1.1, figure 6-7.</p> <p>SPS trim values should be reviewed now for use at beginning of P40 for computing preferred IMU orientation and final vehicle attitude. SPS trim values are updated during CMC-controlled burn. If a roll jet fails on during SPS thrust, an appreciable roll excursion ~30° may occur. PITCH-YAW DAP will continue to function properly.</p>
	<p>CMC - on (req), 8.1.3 ISS - on & orient known (req), 8.1.3 & sec 13 SCS - on (req), 8.4.2</p> <p>Test C/W lamps DAP -- load & activate, including ull sel, 8.2.1</p>		

12.2.1

(P40) G&N SPS THRUSTING

NORMAL BACKUP

APOLLO-SOYUZ TEST PROJECT (ASTP)
OPERATIONS HANDBOOK

STA/T STEP	PROCEDURE	PANEL	REMARKS
	Prethrust prog (req), sec 11		P31 through P38 may have been performed during MINKEY sequence.
	Veh Prep (req), 12.1		
1	ΔV Setup, 7.6.2		
2	Key V37E 00E (non-MINKEY)	2	P00 updates state vector periodically. State vector automatically updated during MINKEY.
3	Key V37E 40E		
	or MINKEY auto call		During MINKEY rendezvous sequence, if VG is computed to be >10 fps, MINKEY controller (R07) automatically calls P40 at completion of targeting sequence (P31 through P37) or in case of NPC sequence (P38), P40 called at completion of gyro torquing (P52) if VG >10 fps.
	Poss PROG alarm (8.1.15)		R02. If no alarm at this point (after R02 exited), CMC computes initial thrust direction and initial value of VG (local vertical), computes preferred IMU orientation, and sets PFRATFLG (preferred attitude flag) and stores desired attitude for use in R60. Final attitude computed in R6C, gimbals trimmed for initial thrust, and 0.5-degree deadband set in RCS DAF.
4	If VG display desired Key V06 N81E VGX, Y & Z (1cl vert at GETI) KEY REL		Display available until average G turned on (GETI minus 30 seconds).
	XXXX.X FPS		

(P40) G&N SPS THRUSTING

APOLLO-SOYUZ TEST PROJECT (ASTP)
OPERATIONS HANDBOOK

STA/T STEP	PROCEDURE	PANEL	REMARKS
	(R60 - Attitude Maneuver)		
5	FL V50 N18 (sel CMC - auto) R, P, Y XXX.XX DEG Establish Total Att disp, 7.2.5		Maneuvers CSM to attitude stored in P40. Maneuver performed automatically by G&N, or manually with an optional final automatic G&N-controlled trim maneuver. Desired final gimbal angles. Both FDAIs should be selected to provide redundant displays. Prevents EMAGs from hitting stops during maneuvers.
AC	Accept EMAG MODE (3) - RATE 2 CMC Att Cont - Auto, 7.1.6 PRO	1	PRO initiates auto maneuver without reviewing final gimbal angles. If review desired prior to auto maneuver, reject option should be selected. If desired, attitude set control panel can then be set to final gimbal angles to provide attitude error information for completion of maneuver manually if G&N fails.
CP	Reject Sel desired Att Cont, 7.1 Mnvr to thrust att ENTR - Go to 7	2	
6	Auto mnvr V06 N18 (final att) R, P, Y XXX.XX DEG		Angles obtained from a VECPOINT calculation. Maneuver rate is as last defined by DAP load.
AC, CP	Mon FDAIs If RHC used or SCS sel, go to 7	1,2	CSM began maneuver to final attitude when PRO keyed in step 5. Refer to 6.1.3, notes 1b and 1c.
CP	7 FL V50 N18 (att trim enbl) R, P, Y XXX.XX DEG	2	Final trim maneuver should be considered essential to SPS ΔV attitudes. Display of final gimbal angles remains in registers. Final attitude trim maneuver performed after gimbal drive and trim check.

12.2.1

(P40) G&N SPS THRUSTING

NORMAL BACKUP

APOLLO-SOYUZ TEST PROJECT (ASTP)
OPERATIONS HANDBOOK

STA/T STEP	PROCEDURE	PANEL	REMARKS
8	Ign prep <u>CAUTION</u> If either bat bus A(B) current fails to incr after cycling respective MN BUS TIE sw, con-figure bats to main buses using cb BAT BUS A(B) BAT C & cb MVA(B) BAT C as necessary.	275	Sets up nontime-critical switching required for thrusting. If necessary for deorbit, STDN dumps and rewinds tape recorder, and changes to HBR. Assumes reconfiguration BAT C to MVA(B) for orbit change; BAT A(B) and BAT C to MVA(B) for deorbit.
-06:00	MN BUS TIE BAT A/C - on (up) Verify bat bus A current incr &/or bat volt decr MN BUS TIE BAT B/C - on (up) Verify bat bus B current incr &/or bat volt decr	5 3 5 3	Verification of current increase for appropriate bat bus via DC AMPS indicator (panel 3) confirms successful operation of main bus tie motor switches. MN BUS TIE BAT A/C and B/C switches at on provide two bat-teries on line for orbit change if cb MVA & B BAT C (2) - open, or three batteries on line for deorbit burn and entry if cbs closed (panel 275).
AC	SPS He VLV tb (both) - bp SPS He VLV (both) - AUTO RHC PWR DIR (both) - OFF SC cont - CMC/AUTO SC CONT - CMC CMC MODE - AUTO SCS TVC (2) - RATE CMD	1	Barber pole indicates helium isolation valves closed. Provides rate damped manual TVC as backup to G&N, if THC - CW. SCS auto or MTVC acceleration command optional, but less desirable backup modes.

(P40) G&N SPS THRUSTING

APOLLO-SOYUZ TEST PROJECT (ASTP)
OPERATIONS HANDBOOK

STA/T STEP	PROCEDURE	PANEL	REMARKS
AC	BWAG MODE (3) - ATT 1/R/ITE 2 DBD/RATE - MIN/LO ATT DBD - MIN RATE - LO LV IND/GPI sw - GPI (verify) TVC GMBL DR (2) - AUTO	1	PITCH and YAW GMBL caution/warning lights (panel 2) indicate overcurrent to actuator motors.
9	GmbL drive & trim check	7	Opens RHC 2 (commander's) breakout switch (dc circuits) to prevent attitude maneuvers through CMC during MTVC checks. During burn, RCS DAP disabled at SPS engine ignition (TFI = 0).
-05:00	RHC 2 - ARMED GMBL MOT P1 & Y1 - START Auto switchover check THC - CW RHC - verify no MTVC control GMBL POS ind (4) - no motion	1	START position is momentary. Also refer to 6.1.1.1, note 12. Enables MTVC and switches TVC to channel 2. Verifies TVC switches from channel 1 to channel 2 (which is off) when THC CW selected.
	Sec TVC check GMBL MOT P2 & Y2 - START Confirm & set trim cont		START position is momentary. Verifies secondary gimbal trim control.

12.2.1

(P4C) G&N SPS THRUSTING

NORMAL BACKUP

AFOLLO-SOYUZ TEST PROJECT (ASTP)
OPERATIONS HANDBOOK

STA/T STEP	PROCEDURE	PANEL	REMARKS
AC	SPS GMBL tv (2) - + & - Set to c.g. trim values	1	Trim values obtained from DAP Data Load (8.2.1), or STDN.
	RHC 2 - Verify MTVC		Gimbals drive in response to RHC movement and return to set-in values when RHC neutral. Verifies control of secondary MTVC loops through RHC. Gimbals move proportional to RHC deflection since MTVC integrator not enabled until engine ignition.
	THC - neut RHC PWR NORM 2 - AC/DC		
	Accept Complete auto att trim		Accept and reject options refer to attitude trim enable flash V50 N18 in step 7.
CP	EMAG MODE (3) - RATE 2 Align CSM in roll CMC Att Cont - Auto, 7.1.6 PRO Returns to V06 N18 disp of step 6	2	Does not imply that any previous checks need be repeated for each trim enable.
AC	Reject Sel desired Att Cont, 7.1 Verify/mnvr to thrust att (V62E for tot att err disp) RHC PWR DIR (both) - MNA/MNB MAN ATT (3) - RATE CMD RATE - HI EMAG MODE (3) - ATT 1/RATE 2	1	Enables manual direct RCS for overriding an auto RCS roll failure during thrusting. If MTVC required, RATE - HI bypasses noise problem in SCS gyro assemblies because of thrusting vibration levels, which can cause spurious RCS roll jet firings.

(P40) G&N SPS THRUSTING

APOLLO-SOYUZ TEST PROJECT (ASTP)
OPERATIONS HANDBOOK

STA/T STEP	PROCEDURE	PANEL	REMARKS
AC	1 or If RATE 1 ΔV planned EMAG MODE PITCH - RATE 1 EMAG MODE YAW - RATE 1 or EMAG MODE (in axis) - RATE 1 Align GDC to IMU if necessary, 8.4.6	1	RATE 1 ΔV should be used for burns where angular change >15° or if gyro assembly 2 failed.
CP	2 Check boresight star EWTR (exit R60) 10 FL V50 N25 00204 (CMC GMBL drive test) Accept PRO Mon GMBL drive seq	2	DEKY display option recommended because of its availability - only need to set ATT SET thumbwheels to DSKY values and defer alignment until just prior to thrust. Manual drive, trim and MTVC check accomplished before CMC gimbal drive test enabled (PRO keyed).

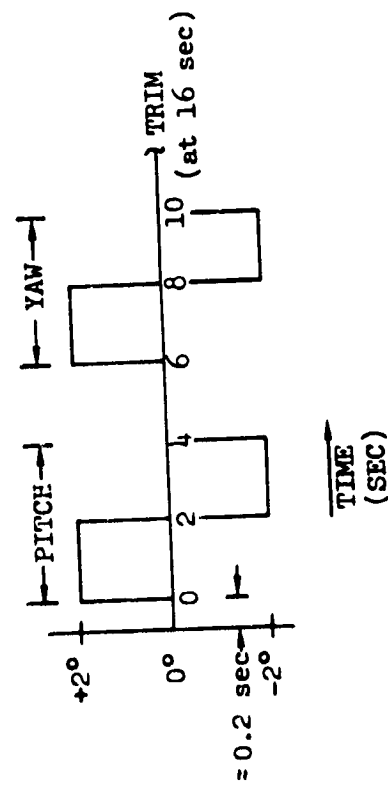

(P40) G&N SPS THRUSTING

12.2.1

NORMAL BACKUP

APOLLO-SOYUZ TEST PROJECT (ASTP)
OPERATIONS HANDBOOK

STA/T STEP	PROCEDURE	PANEL	REMARKS
CP	Reject ENTR GMBLs drive to trim position (after 4 sec)	2	If gimbal test sequence not desired, gimbals drive to trim 4 seconds after ENTR keyed.
11	V06 N40 TF GETI VG ΔV (accum)		TF GETI max reading is 59B59. Sign minus before nominal GETI, plus after. Event Timer will not agree with R1 if GETI was slipped.
AC 12	1-min countdown Report TF GETI = 1 min FDAI SCALE - 5/5 ΔV THRUST A(B) - NORM THC - ARMED RHC (both) - ARMED (R41 - State Vector Integration)	1	Guarded.
-00:40 CP	Poss PROG Alarm Key V05 N09E 01703 (TIC slipped) KEY REL R1 of N40 continues count to former TIC DSKY clears at new TIG -35 sec	2	May illuminate between TIG -42.5 and -35 seconds. TIG slipped delta amount as required by CMC to complete state vector integration
-00:35	COMP ACTY lt - out (exit R41) DSKY clears		
-00:30	V06 N40 (ave G on)		Dynamic, nonflashing display, with COMP ACTY lt flash every 2 seconds.

(P40) G&N SPS THRUSTING

APOLLO-SOYUZ TEST PROJECT (ASTP)
OPERATIONS HANDBOOK

STA/T STEP	PROCEDURE	PANEL	REMARKS
CP	Check ΔV (accum) for PIPA bias R3 <0002.0 FPS	2	G&N controlled burns unreliable if R3 >0002.0 FPS.
DP	UP TLM CMD - RSET then NORM PCM BIT RATE - HI	3	
AC	TAPE RCDR FWD - FWD EMS MODE - NORM	1	6.1.1.1, note 10.
-00:29 to -00:06	Perform ull XXXXXXXXXXXXXXXXXXXXXXXXXXXXX X		2 or 4 jet ullage times defined in MSC-07765-VOL I, Part I. Retain ullage for ≈1 second after ignition. Exact velocity change not critical - only a steady ullage to settle SPS propellants.
	No ull DIR ULL pb - push, hold RHC - control att XXXXXXXXXXXXXXXXXXXXXXXXXXXXX X		Direct ullage inhibits pitch and yaw auto RCS. Maintain attitude within deadband limits.
-00:05 CP 13	FL V99 N40 (eng enbl) TF GETI VG ΔV (accum) XXBXX MIN-SEC XXXX.X FPS XXXX.X FPS	2	CMC changes V06 to V99, but retains previous display in registers. Do not exercise extended verb or monitor displays for extended periods during TVC; these displays can override a FL V97 N40 (low thrust) display which indicates CMC thinks engine off, steering stopped (including cutoff computations), and attitude hold established.

(P40) G&N SPS THRUSTING

12.2.1

NORMAL BACKUP

APOLLO-SOYUZ TEST PROJECT (ASTP)
OPERATIONS HANDBOOK

STA/T STEP	PROCEDURE	PANEL	REMARKS
CP	Accept YRO Go to 14 Reject EWTR, go to 18 as req & 19 Man trim with RCS or V34E FL V37	2	If EWTR option selected, post SPS burn switching in step 18 must be accomplished. If average G on, R00 turns off average G. It also sets or resets RNDVZFLG, TRACK, and UPDATE flags, depending on which programs in progress or called, and may also recycle into P20.
AC 14 Ign 00:00	SPS THRUST lt - on	1	If N46 (digit A) configured for DM off, CMC will not accept V46E or V48E during TVC. Although not expected, if N46 (digit A) configured for DM on, CMC will accept V46E for low bandwidth mode (decreases control required response because of off-nominal bending moments).
CP	V06 N40 TFC VG (decr) ΔV accum (incr) ΔV ind - decr	2 1	Time from engine cutoff. Sign (-) before cutoff, (+) thereafter. TFC display discontinuous for 4 to 5 seconds after ignition.
AC CP	Poss PROG alarm Key V05 N09E (to verify alarm) 01407 (VG incr)	2 1	RCS X-axis translation discontinued by program 2 seconds after engine-on command. RCS DAP disabled at ignition.
IGN+1 sec AC	Discontinue ull		

(P40) G&N SPS THRUSTING

APOLLO-SOYUZ TEST PROJECT (ASTP)
OPERATIONS HANDBOOK

STA/T STEP	PROCEDURE	PANEL	REMARKS
IGN+2 to 5 sec AC	<p>ΔV THRUST (2) - NORM (if desired)</p> <p>XXXXXXXXXXXXXXXXXXXXXXXXXXXXX X</p> <p>If no ign or premature shutdown</p> <p>Continue ull ΔV THRUST (2) - NORM Recycle 14</p>	1	<p>Guarded. For dual bank operation.</p> <p>Engine restart should not be attempted within 5 seconds from initial ignition - avoids undesirable helium pressure excursions.</p> <p>Guarded.</p>
CP	<p>or If FL V97 N40 (P40) PRO - If thrust back on</p>	2	<p>Thrust failure routine (R40) called if CMC detects thrust failure during non-impulsive thrusting period. If thrust decreases to some low level, VG and ΔV displays continue changing. If thrust actually terminates prematurely, VG and ΔV displays become static. For Lambert burns, VG may not become static.</p>
AC	<p>or ΔV THRUST (2) - NORM Reorient to thrust att</p>	1	
CP	<p>EWTR - Recycle to 13</p> <p>or Key V34E FL V37 Key XXE</p> <p>or Sel SCS option</p>	2	<p>If EWTR response to FL V97 N40, R1 (TFC) set to 59B59. A slight delay (≈3 sec) occurs before FL V99 N40 appears.</p> <p>Terminates P40 and R40.</p>

(P40) G&N SPS THRUSTING

12.2.1

NORMAL BACKUP

APOLLO-SOYUZ TEST PROJECT (ASTP)
OPERATIONS HANDBOOK

STA/T STEP	PROCEDURE	PANEL	REMARKS
AC	or Discontinue ull SC CONT - SCS AV THRUST (2) - NORM SCS TVC (2) - AUTO	1	SCS AV option selected to bypass as many failure modes as possible and provide minimum engine delay. Depending on duration of burn prior to failure, a motion transient could result if c.g. shifted significantly from GMBL thumbwheel values.
IGN+1 sec	Initiate ull THRUST ON pb - push or SPS THRUST - DIR ON		Ullage and THRUST ON pushbutton required to satisfy SCS logic if SPS THRUST switch not at DIR ON. Lever lock.
CP	15 Orb change SPS monitor Pc ind - 95-105 psia SPS INJ VLV ind (2 or 4) - OPEN SPS He VLV tb (both) - gray SPS FUEL & OXID PRESS ind (2) - 170-195 psia SPS OXID UNBAL ind - 0 psi	3	65 to 125% green range on indicator corresponds to psia. Normal Pc range 95-105 psia. All four injector valves open for dual-bank operation. Gray indicates helium isolation valves open. PUGS deactivated.
AC	If noncritical burn & ΔP > 20 psi AV THRUST (2) - OFF	1	ΔP between fuel and oxidizer should not exceed 20 psi during burn or degraded performance; rough combustion, and/or engine failure may result.

(P40) CAN SPS THRUSTING

APOLLO-SOYUZ TEST PROJECT (ASTP)
OPERATIONS HANDBOOK

STA/T STEP	PROCEDURE	PANEL	REMARKS
IGN+2 to 5 sec AL	<p>AV THRUST B(A) - NORM (if desired)</p> <p>Initiate ull THRUST ON pb - push</p> <p>or SPS THRUST - DIR ON</p> <p>or Term mnvr</p> <p>XXXXXXXXXXXXXXXXXXXXXXXXXXXXXXXXXXXXX</p> <p>XXXXXXXXXXXXXXXXXXXXXXXXXXXXXXXXXXXXX</p> <p>Roll att cont failure MAN ATT ROLL - ACCEL CMD</p> <p>or AUTO RCS ROLL (8) - OFF</p> <p>Use direct cont</p> <p>XXXXXXXXXXXXXXXXXXXXXXXXXXXXXXXXXXXXX</p>	1	<p>Guarded. For dual bank operation.</p> <p>Ullage and THRUST ON pushbutton required to satisfy SCS logic for second bank operation if SPS THRUST switch not at DIR ON.</p> <p>Lever lock.</p> <p>ACCEL CMD position inhibits CMC roll commands and allows acceleration control of RCS auto coils with RHC.</p>
18 CP	<p>Mon SPS eng cutoff</p> <p>SPS THRUST lt - out</p> <p>FL V16 N40 (eng cutoff)</p> <p>TFC (static at 2.5 sec from cutoff)</p> <p>VG AV (accum)</p> <p>XXXXXXXX.X FPS XXXXXXXX.X FPS</p>	1 2	<p>Time from cutoff. At cutoff +2.5 seconds, CMC sets wide deadband in RCS DAP. Then CMC switches from TVC DAP to RCS DAP at cutoff +3.1 seconds.</p>

(P40) G&N SPS THRUSTING

APOLLO-SOYUZ TEST PROJECT (ASTP)
OPERATIONS HANDBOOK

STA/T STEP	PROCEDURE	PANEL	REMARKS
AC C/O+1 sec	EVNT TMR ind - 59:59 (-) thrust duration AV THRUST (2) - OFF SPS THRUST - NORM (verify) Report eng off Pc = 0	1	Timer normally counts down from 59:59. Guarded. Lever lock.
DP C/O +2.5 sec AC	SPS INJ VLV ind (4) - CLOSE SPS He VLV tb (both) - bp GMBL POS ind (4) - servo null	3 1	Barber pole indicates helium isolation valves closed. CMC removes TVC enable discrete (C/O indicated by TFC sign change and VG → 0).
DP	For postorbit change free drift BWAG MODE (3) - RATE 2 CMC MODE - FREE	3	Decrease verifies gimbal motor shutdown.
AC DP	DC IND sel - SM SOURCE 3 DC AMPS ind - mon for amps decr after each No. 2 gmb1 mot shutdown GMBL MOT PI & Y2 - OFF	1 3	6.1.1.1, note 12.
AC DP	DC IND sel - SM SOURCE 1 or 2 DC AMPS ind - mon for amps decr after each No. 1 gmb1 mot shutdown GMBL MOT PI & Y1 - OFF DC IND sel - MWA	1 3	Decrease verifies gimbal motor shutdown.
AC	If MTVC THC - neut		To prevent possible reignition (if G&N thrust-on command still present), AV THRUST switches must be OFF prior to THC - neutral.
AC	TVC SERVO PWR (both) - OFF	7	

(P40) G&N SPS THRUSTING

12.2.1

NORMAL/BACKUP

APOLLO-SOYUZ TEST PROJECT (ASTP)
OPERATIONS HANDBOOK

STA/T STEP	PROCEDURE	PANEL	REMARKS
AC	If deorbit cb SPS PITCH (both) - open cb SPS YAW (both) - open EMS MODE - STBY PCM BIT RATE - LO Record AV ind PRO	1 3 1 2	6.1.1.1, note 10. CMC sets minimum deadband in RCS DAP.
19	FL V16 N85 (VG vctr compt) VGX, Y, Z (cont) XXXX.X FPS		Velocity to be gained resolved along CSM X, Y, and Z control axes (updated each computation cycle).
AC	If VG compt to be nulled CMC MODE - AUTO or HOLD RHC/THC - null out VG compt THC - neut, LOCKED If orb change RHC - LOCKED	1	Optional. All AUTO RCS switches must be on for nulling residuals in 3 axis.
DP	If deorbit TAPE RCDR FWD - off (ctr)	3	
CP	If R30 desired Key V82E Go to 20 To term P40 PRO Go to 21	2	CMC sets last specified R03 deadband in RCS DAP.

(P40) G&N SPS THRUSTING

APOLLO-SOYUZ TEST PROJECT (ASTP)
OPERATIONS HANDBOOK

STA/T STEP	PROCEDURE	PANEL	REMARKS
20	<p>FL V16 N44 Ha Hp</p> <p>(R30 - Orbital Parameter Display)</p> <p>XXXX.X NM XXXX.X NM</p> <p>XXXX MIN-SEC</p> <p>TFF</p> <p>If Hp > 49.4 NM R3 = -59B59 PRO (exit R30) Return to 19</p>		<p>Altitudes above launch pad radius. Parameter calculations yield reasonable results if vehicle close to earth.</p> <p>Time of free fall to 49.4 NM (300,000 ft) above launch pad radius.</p> <p>If TFF = -59B59, time from perigee available via N32E.</p>
21	<p>FL V37 (non-MINKEY)</p> <p>If orb change Key XXE (non-MINKEY) Set controls after tailoff</p> <p>MN BUS TIE (2) - OFF</p> <p>XXXXXXXXXXXXXXXXXXXXXXXXXXXX XXXXXXXXXXXXXXXXXXXXXXXXXXXX</p> <p>If MN BUS TIE fail prior to thrust Leave MN BUS TIE BAT B/C(A/C) - on (up) Go to EPS Malf, Pwr Distr, SSR-2 reconfig for subsequent main bus ties</p> <p>XXXXXXXXXXXXXXXXXXXXXXXXXXXX XXXXXXXXXXXXXXXXXXXXXXXXXXXX</p>		<p>If average G on, R00 turns off average G. R00 also sets or resets RNDVZFLG, TRACK, and UPDATE flags, depending on which programs in progress or called, and may also recycle into P20.</p> <p>Monitor main bus voltage for maximum allowable (31 vdc) during power down sequence.</p> <p>Circuit breakers used to reconfigure for subsequent bat bus operation and battery charging procedures in place of opening (known) good main bus tie motor switches. Malfunction procedures are in Flight Data File (FDF).</p>
DP		5	

(P40) G&N SPS THRUSTING

12.2.1

NORMAL BACKUP

APOLLO-SOYUZ TEST PROJECT (ASTP)
OPERATIONS HANDBOOK

STA/T STEP	PROCEDURE	PANEL	REMARKS
CP	Rcd burn data	2	Recorded burn data should include ΔV accomplished and SPS propellant quantity remaining.
AC	EMS FUNC - OFF THC PWR - OFF RHC PWR DIR (both) - OFF Charge bats, 5.3.5	1	
CP	If MINKEY, go to next MINKEY seq or If deorbit Rcd burn data Key 6LE Go to CM/SM Sep, 14.2	2	MINKEY controller proceeds to next targeting program in MINKEY sequence. Recorded burn data should include ΔV accomplished.

(P40) G&N SPS THRUSTING

APOLLO-SOYUZ TEST PROJECT (ASTP)
OPERATIONS HANDBOOK

STA/T STEP	PROCEDURE	PANEL	REMARKS
12.2.2	<p>(P41) G&N/SM-RCS Thrusting</p> <p>CMC - on (req), 8.1.3 ISS - on & orient known (req), 8.1.3 & sec 13 SCS - on (req), 8.4.2</p> <p>Test C/W lamps Prethrust prog (req), sec 11</p> <p>Veh Prep (req), 12.1 DAP - Load & Activate, (R03) 8.2.1, or (R04), 8.2.2</p>		<p>Computes preferred CSM attitude and preferred IMU orientation for RCS thrust, and maneuvers CSM to thrust attitude (R60).</p> <p>G&C circuit breakers on all panels should be closed except as defined in Limited Use Controls, 6.1.1, figure 6-7.</p> <p>P31 through P38 may have been performed during MINKEY sequence.</p> <p>During MINKEY rendezvous sequence, if VG is computed to be <10 fps, controller automatically calls P41 at completion of targeting sequence (P31 through P37) or in case of NPC sequence (P38), P41 called at completion of P52 if gyros not torqued, or if gyros torqued and VG <10 fps.</p> <p>May be R03 and V46E if not docked, or R04 and V45E if CSM docked to Soyuz.</p> <p>TFI available (prior to step 11) via N35, N40, or N45.</p>
AC	1 Set EVNT TMR to read 00:00 at GETI	1	
CP	2 Key V37E 00E (non-MINKEY)	2	
	3 Key V37E 41E		
	or MINKEY auto call		

(P41) G&N SM RCS THRUSTING

12.2.2

NORMAL BACKUP

APOLLO-SOYUZ TEST PROJECT (ASTP)
OPERATIONS HANDBOOK

STA/T STEP	PROCEDURE	PANEL	REMARKS
CP	Poss PROG alarm (8.1.16)	2	R02. If no alarms at this point (after R02 exited), CMC computes initial thrust direction and initial value of VG (local vertical), computes preferred IMU orientation, and sets PFRATFLG (preferred attitude flag) and stores desired attitude for use in R60. Final attitude computed in R60 and 0.5-degree dead-band set in RCS DAP.
4	If VG disp desired Key V06 N81E VGX, Y, Z (Lcl vert at GETI) KEY REL (R60 - Attitude Maneuver)		Display available until average G turned on (GETI -30 seconds).
5	FL V50 N18 (select CMC - auto) R, P, Y XXX.XX DEG Establish Tot Att disp, 7.2.5		Maneuvers CSM to attitude stored in P41. Maneuver performed automatically by G&N, or manually with optional final automatic G&N controlled trim maneuver. Desired final gimbal angles.
AC	Accept BMAG MODE (3) - RATE 2 CMC Att Cont - auto, 7.1.6 PRO	1	Both FDAIs should be selected to provide redundant displays.
CP	Reject Sel desired Att Cont, 7.1 Mnvr to thrust att ENVR, go to 8	2	Prevents BMAGs from hitting stops during maneuvers. Initiates auto maneuver without review of final gimbal angles.

(P41) G&N SM RCS THRUSTING

APOLLO-SOYUZ TEST PROJECT (ASTP)
OPERATIONS HANDBOOK

STA/T STEP	PROCEDURE	PANEL	REMARKS
CP 6	Auto mnvr V06 N18 (fnl att) R, P, Y Mon FDAIs If RHC used or SCS sel, go to 7	2 1,2	CSM began maneuver to final attitude when PRO keyed in step 5. ICDU drives to achieve final gimbal angles. Refer to 6.1.3, notes: lb and lc. Step should be completed prior to TIG -2 minutes. Display of final gimbal angles in registers.
AC	FL V50 N18 (att trim enbl) R, P, Y		
CP 7	Accept EMAG MODE (3) - RATE 2 CMC Att Cont - Auto, 7.1.6 PRO Return to V06 N18 display of 6	1 2	Does not imply that any previous checks need be repeated for each trim enable.
AC	Reject Sel desired Att Cont, 7.1 Verify/mnvr to thrust att (V62E for total att err disp)		All RCS channels required for 3-axis translation.
CP 8	MAN ATT (3) - RATE CMD EMAG MODE (3) - ATT 1/RATE 2 Align GDC to IMU if necessary, 8.4.6	1	DSKY display option recommended because of its availability - only need to set ATT SET thumbwheels to DSKY values and defer alignment until just prior to thrust.
AC	EMTR (exit R60)	2	Components resolved along CSM axes, and updated at 1-second intervals.

12.2.2

(P41) G&N SM RCS THRUSTING

NORMAL BACKUP

APOLLO-SOYUZ TEST PROJECT (ASTP)
OPERATIONS HANDBOOK

STA/T STEP	PROCEDURE	PANEL	REMARKS
-05:00	9 Ign prep		
AC	Check boresight star For X axis thrust THC PWR - on (up) If orb change AV Test and Null Bias Check, 7.6.1 AV Setup, 7.6.2 (R41 - State Vector Integration)	1	Sets up nontime-critical switching required for thrust. For deorbit thrust, check accomplished during EMS Entry Test, 14.1.1.3, if desired. Set to ΔV obtained from charts, P30, and/or STDN.
-00:40 CP	Poss PROG alarm Key V05 N09E 01703 (TIG slipped) KEY REL R1 of R40 continues count to former TIG DSKY clears at new TIG -35 sec	2	May illuminate between TIG -42.5 and -35 seconds. TIG slipped delta amount as required by CMC to complete state vector integration.
-00:35	10 COMP ACTY lt - out (exit R41) DSKY clears		
-00:30	11 V16 N85 (ave G on)		Dynamic, nonflashing display with COMP ACTY light flash every 2 seconds.

(P41) G&N SM RCS THRUSTING

APOLLO-SOYUZ TEST PROJECT (ASTP)
OPERATIONS HANDBOOK

STA/T STEP	PROCEDURE	PANEL	REMARKS
-00:25	THC - ARMED		
AC	RHC (both) - ARMED		
AC,CP	LIM CYCLE - OFF	1	For SCS translations.
AC	UP TIM CMD - RSET then NORM	3	
DP	PCM BIT RATE - HI		
AC	TAPE RCDR FWD - FWD	1	6.1.1, note 10.
AC	EMS MODE - NORM		
00:00			
12	RCS thrust	2	Event Timer not valid if GETI slipped.
CP	FL V16 N85 (requests null VG) VGX, Y, Z (cont) XXXX.X FPS		Command manual translations and rotations to null VG components.
AC	Man null VG		
CP	If R30 desired Key V82E Go to 13		
	To term P41 PRO Go to 14		CMC sets last specified R03 deadband in RCS DAP.
	(R30 - Orbital Parameter Display)		R30 displays automatically updated at 2-second intervals if called because average G still on.
13	FL V15 N44 :a Hp TFF		Altitudes above launch pad radius. Time of free fall to 49.4 NM (300,000 ft) above launch pad radius.

(P41) G&N SM RCS THRUSTING

12.2.2

NORMAL BACKUP

APOLLO-SOYUZ TEST PROJECT (ASTP)
OPERATIONS HANDBOOK

STA/T STEP	PROCEDURE	PANEL	REMARKS
CP	If Hp > 49.4 NM R3 = -59B59 PRO (exit R30) Return to 12	2	If TFF = -59B59, time from perigee available via N32E.
14	Thrust complete	1	6.1.1.1, note 10.
AC	EMS MODE - STBY	3	
DP	PCM BIT RATE - LO	1	
AC	Red ΔV ind		
	If orb change		
	EMS FUNC - OFF		
	THC PWR - OFF		
AC, CP	RHC (both) - LOCKED		
	If deorbit		
DP	TAPE RCDR FWD - off (ctr)	3	
AC	THC - neut, LOCKED		
CP	15 FL V37 (non-MINKEY)	2	If average G on, R00 turns off average G. It also sets or resets RNDVZFLG, TRACK, and UPDATE flags, depending on which programs in progress or called, and may also recycle into P20.
	If orb change		
	Key XXE		
	or		
	If deorbit		
	Key 6LE (if desired)		
	Go to CM/SM Sep, 14.2		
	If MINKEY, go to next MINKEY seq		P61 may be bypassed if hybrid or SCS deorbit. MINKEY controller proceeds to next targeting program in MINKEY sequence.

(P41) G&N SM RCS THRUSTING

APOLLO-SOYUZ TEST PROJECT (ASTP)
OPERATIONS HANDBOOK

STA/T STEP	PROCED. RE	PANEL	REMARKS
12.2.3	<p><u>G&N/Hybrid Deorbit Thrusting</u></p> <p>CMC - on (req), 8.1.3 ISS - on & orient known (req), 8.1.3 & sec 13 SCS - on (req), 8.4.2</p> <p>Test C/W lts Prethrust prog (req), sec 11 Veh Prep (req), 12.1 DAP - Load & Activate, 8.2.1</p>		<p>Computes preferred CSM attitude and preferred IMU orientation for RCS thrusting maneuver. Maneuvers CSM to thrusting attitude (R60), and provides sufficient displays for cutoff of both SM RCS burn followed by CM RCS deorbit burn.</p> <p>G&C circuit breakers on all panels should be closed except as defined in Limited Use Controls, 6.1.1, figure 6-7.</p>
AC	<p>1 Set EVNT TMR to read 00:00 at GETI Key V37E 00E</p>	1	POO updates state vector periodically.
CP	<p>2 Key V37E 41E</p> <p>Poss PROG alarm (8.1.16)</p>	2	<p>TFI available via N35, N40, or N45.</p> <p>R02. If no alarms at this point (after R02 exited), CMC computes initial thrust direction and initial value of VG (local vertical), computes preferred IMU orientation, sets PFRATFIG (preferred attitude flag), and stores desired attitude for use in R60. Final attitude computed in R60 and 0.5-degree deadband set in RCS DAP.</p>

12.2.3

G&N HYBRID DEORBIT THRUSTING

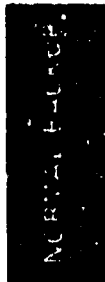

APOLLO-SOYUZ TEST PROJECT (ASTP)
OPERATIONS HANDBOOK

STA/T STEP	PROCEDURE	PANEL	REMARKS
C	3 If VG disp desired Key VC6 N81E VGX, Y, Z (Lcl vert at GETI) (R60 - Attitude Maneuver)	2	Display available until average G turned on (GETI -30 seconds). Maneuvers CSM to attitude stored in P41. Maneuver performed automatically by G&N, or manually with an optional final automatic G&N controlled trim maneuver.
	4 FL V50 N18 (sel CMC - auto) R, P, Y XXX.XX DEG Establish Tot Att disp, 7.2.5		Both FDAIs should be selected to provide redundant displays.
AC	Accept EMAG MODE (3) - MATE 2	1	Prevents EMAGs from hitting stops during maneuvers.
CP	CMC Att Cont - auto, 7.1.6 PRO	2	Initiates auto maneuver without review of final gimbals angles.
AC CP	5 Auto mnvr V06 N18 (final att) R, P, Y XXX.XX DEG		
AC,CP	Monitor FDAIs If RHC used or SCS sel, go to 6	1,2	CSM began maneuver to final attitude when PRO keyed in step 4. ICDU drives to achieve final gimbals angles. Refer to 6.1.3, not 2 lb.

G&N HYBRID DEORBIT THRUSTING

APOLLO-SOYUZ TEST PROJECT (ASTP)
OPERATIONS HANDBOOK

STA/T STEP	PROCEDURE	PANEL	REMARKS
CP 6	FL V50 N18 (att trim enbl) R, P, Y XXX.XX DEG	2	Step should be completed prior to TIG -2 minutes. Display of final gimbal angles in registers.
AC	Accept BMAG MODE (3) - RATE 2	1	
CP	CMC Att Cont - auto, 7.1.6 PRO, return to 5	2	
AC	Reject Sel desired Att Cont, 7.1		
CP	Verify/mnvr to thrust att (V62E for tot att err disp)		
AC	MAN ATT (3) - RATE CMD BMAG MODE (3) - ATT 1/RATE 2	1	DSKY display option recommended because of its availability - only need to set ATT SET thumbwheels to DSKY values and defer alignment until just prior to thrust.
CP	ENTR (exit R60)	2	Components resolved along CSM axes and updated at 1-second intervals.
7	Mon VG disp V06 N85 (VG vctr compnts) VGX, Y, Z (cont) XXXX.X FPS		Prepares for battery preloading prior to CM/SM separation and verifies batteries transferred to main buses.
DP 8	Configure & preload bats		Assumes reconfiguration BAT A(B) and BAT C to MVA(B). cb MVA(B) BAT C closed in Deorbit and Entry Vehicle Preparation, 14.1.1.
	<u>CAUTION</u>		
	If either bat bus A(B) current fails to incr after cycling MN BUS TIE sws, configure bats to main buses using cb BAT BUS A(B) BAT C.	275	

G&N HYBRID DEORBIT THRUSTING

12.2.3

NORMAL BACKUP

APOLLO-SOYUZ TEST PROJECT (ASTP)
OPERATIONS HANDBOOK

STA/T STEP	PROCEDURE	PANEL	REMARKS
-06:00 DP	MN BUS TIE BAT A/C - on (up) Verify bat bus A current incr &/or bat volt decr MN BUS TIE BAT B/C - on (up) Verify bat bus B current incr &/or bat volt decr	5 3 5 3	Verification of current increase for appropriate battery bus via DC AMPS indicator (panel 3) confirms successful operation of main bus tie motor switches. MN BUS TIE BAT A/C and B/C switches at on provide two batteries on line if circuit breaker MNA & B BAT C (2) - open, or three batteries on line for deorbit and entry if circuit breakers closed (panel 275).
-05:00 AC 9	Ign prep THC PWR - on (up) ΔV Setup, 7.6.2 (R41 - State Vector Integration)	1	Sets up nontime-critical switching required for thrusting. Set to ΔV obtained from charts, P30, and/or STDN.
-00:40 CP	Poss PROG alarm Key V05 N09E 01703 (TIG slipped) KEY REL R1 of N40 continues count to former TIG DSKY clears at new TIG -35 sec	2	May illuminate between TIG -42.5 and -35 seconds. TIG slipped delta amount as required by CMC to complete state vector integration.
-00:35	10 COMP ACTY lt - out (exit R41) DSKY clears		
-00:30	11 V16 N85 (ave G on)		Dynamic, nonflashing display with COMP ACTY light flash every 2 seconds.

G&N HYBRID DEORBIT THRUSTING

APOLLO-SOYUZ TEST PROJECT (ASTP)
OPERATIONS HANDBOOK

STA/T STEP	PROCEDURE	PANEL	REMARKS
-00:25 AC, CP AC	RHC (both) - ARMED THC - ARMED LIM CYCLE - OFF UP TLM CMD - RSET then NORM PCM BIT RATE - HI TAPE RCDR FWD - FWD EMS MODE - NORM	1 3	For SCS translations.
00:00 AC	SM RCS thrust FL V16 N85 (request null VG) VGX, Y, Z (cont) XXXX.X FPS	1	6.1.1.1, note 10.
CP 12		2	Event Timer not valid if GETI slipped.
AC	Man null VG Mon DSKY, ΔV ind, & EVNT TMR	1,2	Command manual translation and rotation to null VG components.
CP	Crew options V83 - R, R dot, θ V82 - Ha, Hp, TFF	2	
AC	SM RCS thrust complete	1	
DP	EMS MODE - STBY	3	
CP	PCM BIT RATE - LO	1,2	
AC	Rcd DSKY, ΔV ind, & EVNT TMR values Resct EVNT TMR THC - neut, LOCKED	1	6.1.1.1, note 10.
14	Sel SCS Att Cont mode, 7.1		Separation follows immediately, preventing proper G&N DAP operation until entry DAP selected in P62.
15	Perform Sep proced, 14.2		Separation at SM deorbit attitude saves time. Only one minute allowed between burns.

G&N HYBRID DEORBIT THRUSTING

12.2.3

NORMAL BACKUP

APOLLO-SOYUZ TEST PROJECT (ASTP)
OPERATIONS HANDBOOK

STA/T STEP	PROCEDURE	PANEL	REMARKS
AC 16	Verify/mnvr to CM RCS deorbit att R _____, P _____, Y _____ MAN ATT YAW, ROLL - RATE CMD MAN ATT PITCH - ACCEL CMD DBD/RATE - MIN/HI ATT DBD - MIN RATE - HI RHC (both) - ARMED FDAI SCALE - 5/5	1	Both CM RCS systems should be enabled. CM RCS deorbit portion complete with +X axis =70° below velocity vector (apex down and forward); =110° +pitch maneuver from heads down, REF, SM RCS portion of deorbit.
AC, CP AC	Key V82E FL V16 N44 Ha Hp TFF	2	Altitudes above launch pad radius. Time of free fall to 49.4 NM (300,000 ft) above launch pad radius.
AC 18	EYMT TMR ind - SM RCS C/O +2 min EMS MODE - NORM RHC 1 - contin -pitch RHC 2 - pulse to maintain att in pitch axis Mon FDAI	1	Two minutes after SM RCS cutoff, start CM RCS burn. 6.1.1, note 10. Negative pitch engines have =25 to 30 percent less authority than positive engines because of engine location and thrust direction relative to CM c.g.
AC, CP	XXXXXXXXXXXXXXXXXXXXXXXXXXXXXXXXXXXXX X If only 1 RHC Pulse RHC + & - in pitch from pitch retro att, maintaining rates <3°/sec XXXXXXXXXXXXXXXXXXXXXXXXXXXXXXXXXXXXX		

G&N HYBRID DEORBIT THRUSTING

APOLLO-SOYUZ TEST PROJECT (ASTP)
OPERATIONS HANDBOOK

STA/T STEP	PROCEDURE	PANEL	REMARKS
CP 19	Mon Hp & TFF on DSKY	2	Monitor Event Timer for duration of burn no greater than 02:10 for either single or dual system. Conserve CM RCS propellant reserves, 30 lb each system for entry. ΔV indicator cutoff cue must be adjusted to account for EMS sensing axis (along X) being reversed from SM RCS deorbit burn and biased off $\pm 70^\circ$ from CM RCS velocity vector. ($\Delta V_{ems} = \Delta V_{cm} \cos 70^\circ$).
20	PRO FL V16 N85 VGX, Y, Z (cont) XXXX.X FPS		
21	Thrust complete, ΔV ind = _____ or EVENT TMR = _____ PRO MAN ATT (3) - RATE CMD Rcd ΔV ind, DSKY, EVENT TMR TAPE RCDR FWD - off (ctr) ATT DBD - MAX	1 2 1 1,2 3 1	
CP 22	FL V37	2	6.1.1, note 10.
AC	EMS MODE - STBY	1	
AC,CP	RHC (both) - LOCKED		
AC 23	Set Att Cont mode, 7.1 Mnvr to entry att R _____, P _____, Y _____		
24	Set up for CM RCS sys 1 AUTO RCS A/C ROLL (4) - OFF AUTO RCS CM 1 (6) - MNA or MNB AUTO RCS CM 2 (6) - OFF	8	Electrically isolates system 2 for entry. If problem develops in system 1, disable affected channel and use direct RCS control.
25	Go to G&N Entry, 14.3		

G&N HYBRID DEORBIT THRUSTING

12.2.3

NORMAL BACKUP

APOLLO-SOYUZ TEST PROJECT (ASTP)
OPERATIONS HANDBOOK

STA/T STEP	PROCEDURE	PANEL	REMARKS
12.3	SCS THRUSTING		
12.3.1	SCS/SPS Thrusting		
	CMC - on (desired), 8.1.3 ISS - on & orient known (desired), 8.1.3 & sec 13 SCS - on (req), 8.4.2		CMC and ISS on, and orientation known, necessary for P47 monitor.
	Vehicle P. p (req), 12.1		G&C circuit breakers on all panels should be closed except as defined in Limited Use Controls, 6.1.1.1, figure 6-7.
	For small impulse SPS/SCS burn Set ΔV ind - ΔVc		Initial counter setting (ΔVc) and counter reading for SPS ignition cue (ΔVc) will be provided by SIDN or determined from on-board charts. (Ref CSM Data Book Vol I, Part I.)
CP	1 ΔV Setup, 7.6.2 2 Key V37E 00E 3 Establish Tot Att disp, 7.2.5 4 SCS Att Mvvr to thrust att, 8.4.5 5 Establish SCS Att Hold, 7.1.4 Check boresight star 6 Ign prep	2	P00 updates state vector periodically. To obtain telemetry on BMAG attitude error, FDAI SEL switch must be in 1 or 2 position (with SCS displays). Limit cycle, maximum deadband and low rate should be selected for propellant conservation. Sets up nontime-critical switching required for thrusting.

SCS/SPS THRUSTING

APOLLO-SOYUZ TEST PROJECT (ACTP)
OPERATIONS HANDBOOK

STA/T STEP	PROCEDURE	PANEL	REMARKS
DP	SPS He VLV tb (both) - bp SPS He VLV (both) - AUTO <u>CAUTION</u> If either bat bus A(B) current fails to incr after cycling MN BUS TIE sws, configure bats to main buses using cb BAT BUS A(B) BAT C & cb MNA(B) BAT C as necessary.	3 275	Barber pole indicates helium isolation valves closed. Assumes reconfiguration BAT C to MNA(B) for orbit change; BAT A(B) and BAT C to MNA(B) for deorbit.
-06:00	MN BUS TIE BAT A/C - on (up) Verify bat bus A current incr &/or bat voltage decr MN BUS TIE BAT B/C - on (up) Verify bat bus B current incr &/or bat voltage decr	5	Verification of current increase for appropriate bat bus via DC AMPS indicator (panel 3) confirms successful operation of main bus tie motor switches. MN BUS TIE BAT A/C and B/C switches at on provide two batteries on line for orbit change if cb MNA & B BAT C (2) - open, or three batteries on line for deorbit burn and entry if cbs closed (panel 275).
AC	LV IND/GPI sw - GPI (verify) RHC PWR DIR (both) - OFF SCS TVC (2) - AUTO TVC GMBL DR (2) - AUTO ATVC GAIN - HI Establish Ull Sel, 6.1	1	LO position provides proper response for tv control of SPS gimbals.
CP	7 If P47 for thrust monitor Key V37E 47E Poss PROG alarm (8.1.16)	2	GN& monitoring highly desirable but not required. Refer to 8.1.6 for P47 description. RO2.

12.3.1

SCS/SPS THRUSTING

NORMAL/BACKUP

APOLLO-SOYUZ TEST PROJECT (ASTP)
OPERATIONS HANDBOOK

S/A/T STEP	PROCEDURE	PANEL	REMARKS
CF	FL V16 N83 ΔVX, Y, Z (cont) XXXX.X FPS If desired KEY M62E VI XXXXX. FPS H dot XXXXX. FPS H pad XXXX.X NM KEY REL (to return to N83)	2	Inertial velocity. Altitude rate. Altitude above launch pad radius.
AC	8 Gmb1 drive & trim check TVC SERVO PWR 1 - AC1/MNA TVC SERVO PWR 2 - AC2/MNB cb SPS PITCH 1 BAT A - close (verify) cb SPS YAW 1 BAT A - close (verify) THC PWR - on (up) RHC PWR NORM 2 - AC RHC 2 - ARMED	7	PITCH and YAW GMBL caution/warning lights indicate overcurrent to actuator motors. Remain closed from launch through first SPS thrust and closed again for each subsequent SPS thrusting.
-05:00	Primary TVC check GMBL MOT P1 & Y1 - START Verify trim control on ind	1	Opens RHC 2 (commander's) breakout switch dc circuits to prevent loss of attitude reference. Prevents RCS jets from firing when RHC used for MFVC check. Normally, IGN 1 signal disables RCS pitch and yaw channels 1 second after SPS engine ignition. 6.1.1, note 12. START position is momentary. Gimbals drive in response to thumbwheel movement. Verifies primary gimbal trim control.

SCS/SPS THRUSTING

APOLLO-SOYUZ TEST PROJECT (ASTP)
OPERATIONS HANDBOOK

STA/T STEP	PROCEDURE	PANEL	REMARKS
AC	<p>Auto switchover check THC - CW RHC 2 - verify no MTVC GMBL POS ind (4) - no motion</p> <p>Sec TVC check GMBL MOT P2 & Y2 - START Verify trim control</p> <p>Verify MTVC THC - neut</p>	1	<p>Verifies TVC control switches from channel 1 to channel 2 (which is off) when THC - CW.</p> <p>START position is momentary. Verifies secondary gimbal trim control.</p> <p>Gimbals drive in response to RHC movement, and return to set-in values when RHC neutral. Verifies control of secondary MTVC loops through RHC.</p> <p>Gimbals trimmed in primary channel to thrusting values (SCS modes).</p>
9	<p>RHC PWR DIR (both) - MNA/MNB fml desired gmb position</p>		<p>Enables manual direct RCS for overriding a roll auto RCS failure during thrusting.</p>
	<p>RHC 2 - null att err</p>		<p>Needles can be used as error null reference during MTVC contingency takeover from automatic ΔV mode.</p>
	<p>ATT DBD - MIN RHC PWR NORM (both) - AC/DC Check boresight star</p>		<p>Set to MIN as errors nulled.</p>
CP 10	<p>1-min countdown Report TF GETI = 1 min</p>	2	
-01:00 AC	<p>FDAI SCALE - 5/5 ΔV THRUST A(B) - NORM</p>	1	<p>Guarded.</p>

SCS/SPS THRUSTING

12.3.1

NORMAL BACKUP

APOLLO-SOYUZ TEST PROJECT (ASTP)
 OPERATIONS HANDBOOK

STA/T STEP	PROCEDURE	PANEL	REMARKS
AC	THC - ARMED	1	
DP	LIM CYCLE - OFF UP TLM CMD - RSET, then NORM PCM BIT RATE - HI TAPE RC DR FWD - FWD EMS MODE - NORM	3	6.1.1, note 10.
-00:30 AC	Perform ull	1	2 or 4 jet ullage times defined in MSC-07765-Vol I, Part I. Exact velocity change not critical - only steady ullage to settle SPS propellants.
-00:29 to -00:06	For small impulse SPS/SCS burn THC - +X Mon EMS counting down When EMS ind = ΔVf THRUST ON pb - push SPS THRUST lt - on Discontinue ull when SPS thrusting		
	XX No ull DIR ULL pb - push, hold RHC 2 - control att XX		Direct ullage inhibits pitch and yaw auto RCS control. Attitude should be maintained manually.
11 00:00	Orb change ign If ull present THRUST ON pb - push		Engine restart should not be attempted within 5 seconds from initial ignition - avoids undesirable He pressure excursions.

SCS/SPS THRUSTING

APOLLO-SOYUZ TEST PROJECT (ASTP)
OPERATIONS HANDBOOK

STA/T STEP	PROCEDURE	PANEL	REMARKS
AC	If no ull present THC - +X, hold THRUST ON pb - push SPS THRUST lt - on	1	Provides ullage discrete to SCS.
IGN+1 sec	RATE - HI		Bypasses noise problem in SCS gyro assemblies because of thrusting vibration levels and provides backup to auto selection of high rate in pitch and yaw TVC.
IGN +2 to 5 sec	Discontinue ull ΔV THRUST (2) - NORM (if desired)		For dual bank operation.
	Initiate ull THRUST ON pb - push xxxxxxxxxxxxxxxxxxxxxxxxxxxxxxxxxxxxxxx x		Ullage and THRUST ON pushbutton required to satisfy SCS logic for second bank operation.
	If no ign, or premature shutdown ΔV THRUST (2) - NORM Recycle ll		
	or SPS THRUST - DIR ON Recycle ll		Lever lock.
	or Term mnvr xxxxxxxxxxxxxxxxxxxxxxxxxxxxxxxxxxxxxxx x		
12 00:00	Deorbit ign SPS THRUST - DIR ON SPS THRUST lt - on		Engine restart should not be attempted within 5 seconds from initial ignition to avoid undesirable He pressure excursions.

SCS/SPS THRUSTING

12.3.1

NORMAL BACKUP

APOLLO-SOYUZ TEST PROJECT (ASTP)
OPERATIONS HANDBOOK

STA/T STEP	PROCEDURE	PANEL	REMARKS
AC IGN+1 sec	RATE - HI XXXXXXXXXXXXXXXXXXXXXXXXXXXXX X If no ign ΔV THRUST (2) - NORM Recycle 12 or Term mnvr XXXXXXXXXXXXXXXXXXXXXXXXXXXXX X	1	Bypasses noise problem in SCS gyrc assemblies because of thrusting vibration levels and provides backup to auto selection of high rate in pitch and yaw TVC. Guarded.
IGN +2 to 5 sec	Discontinue ull ΔV THRUST (2) - NORM		Guarded.
13	Orb change SPS monitor Pc ind - 95-105 psia		65 to 125% green range on indicator corresponds to psia. Normal range 95-105 psia.
DP	SPS INJ VLV ind (2 or 4) - OPEN SPS He VLV tb (both) - gray SPS FUEL & OXID PRESS ind (2) - 170-195 psia SPS OXID UNBAL ind - 0 psi	3	All four injector valves open for dual-bank operation. Gray indicates helium isolation valves open. PUGS deactivated.
	<u>CAUTION</u> If noncritical burn & ΔP >20 psi.		ΔP between fuel and oxidizer should not exceed 20 psi during burn or degraded performance, rough combustion and/or engine failure may result.
AC	ΔV THRUST (2) - OFF	1	Guarded.

SCS/SPS THRUSTING

APOLLO-SOYUZ TEST PROJECT (ASTP)
OPERATIONS HANDBOOK

STA/T STEP	PROCEDURE	PANEL	REMARKS
AC DP	14 Deorbit SPS Monitoring Pc ind - 95-105 psia SPS IMJ VLV ind (4) - OPEN SPS He VLV tb (both) - gray SPS FUEL & OXID PRESS ind (2) - 170-195 psia	1 3	Gray indicates helium isolation valves open.
AC or CP	15 FDAI - mon att err & rates XXXXXXXXXXXXXXXXXXXXXXXXXXXXXXXXXXXX X	1,2	
AC	Orb change MTVC takeover If pitch & yaw err & rates abnormal ΔV THRUST (2) - OFF Damp rates to IMU ball or out window with RHC If no response Use dir RCS & disable affected chan If rate needle(s) abnormal EMAG MODE - RATE 1 Reorient to thrust att THC - CW ΔV THRUST A(B) - NORM Initiate ull THRUST ON pb - push or SPS THRUST - DIR ON	1	Backup procedure bypasses maximum possible failure modes, thereby providing alternate means of completing burn without troubleshooting. Since a failure causing abnormal TVC and RCS attitude control is not a failed-on jet, RCS disabling should be done with MAN ATT switch to ACCEL CMD rather than AUTO RCS switches OFF, thereby providing auto RCS control for reorientation. Guarded. Lever lock

SCS/SPS THRUSTING

12.3.1

NORMAL BACKUP

APOLLO-SOYUZ TEST PROJECT (ASTP)
OPERATIONS HANDBOOK

STA/T STEP	PROCEDURE	PANEL	REMARKS
AC IGN+2 to 5 sec	<p>Fly MTVC (rate cmd)</p> <p>AV THRUST B(A) - NORM (if desired)</p> <p>Initiate ullage THRUST ON pb - push</p> <p>or SPS THRUST - DIR ON</p> <p>or Term mnvr</p> <p>XXXXXXXXXXXXXXXXXXXXXXXXXXXXXXXXXXXXX</p> <p>XXXXXXXXXXXXXXXXXXXXXXXXXXXXXXXXXXXXX</p> <p>Orb change roll err & rates abnormal & no roll att cont MAN ATT ROLL - ACCEL CMD RHC - cont rcll rates</p> <p>or AUTO RCS (16) - OFF Cont roll using dir RCS</p> <p>XXXXXXXXXXXXXXXXXXXXXXXXXXXXXXXXXXXXX</p> <p>XXXXXXXXXXXXXXXXXXXXXXXXXXXXXXXXXXXXX</p>	1	<p>For dual bank operation.</p> <p>Ullage and THRUST ON pushbutton required to satisfy SCS logic for second bank operation if SPS THRUST switch not at DIR ON.</p> <p>Lever lock.</p>
	<p>or AUTO RCS (16) - OFF Cont roll using dir RCS</p> <p>XXXXXXXXXXXXXXXXXXXXXXXXXXXXXXXXXXXXX</p> <p>XXXXXXXXXXXXXXXXXXXXXXXXXXXXXXXXXXXXX</p>	8	<p>Backup procedure bypasses maximum possible failure modes, thereby providing an alternate means of completing burn without troubleshooting.</p> <p>Lever lock.</p>
	<p>Decorbit MTVC takeover If err & rates abnormal: AV THRUST (2) - OFF Damp rates to IMU ball or out window with RHC SPS THRUST - NORM</p>	1	<p>Lever lock.</p>

SCS/SPS THRUSTING

APOLLO-SOYUZ TEST PROJECT (ASTP)
OPERATIONS HANDBOOK

STA/T STEP	PROCEDURE	PANEL	REMARKS
AU	<p>If no response Use dir RCS & disable affected chan</p> <p>If rate needle(s) abnormal EMAG MODE - RATE 1</p> <p>Reorient to thrust att THC - CW ΔV THRUST A(B) - NORM Initiate ull SPS THRUST - DIR ON Fly MIVC (rate cmd)</p> <p>IGN+2 to 5 sec or Term mnvr</p> <p>XXXXXXXXXXXXXXXXXXXXXXXXXXXXXXXXXXXXX XXXXXXXXXXXXXXXXXXXXXXXXXXXXXXXXXXXXX Decrbit nc roll att cont MAN ATT ROLL - ACCEL CMD RHC - cont roll rates</p> <p>or AUTO RCS (16) - OFF Cont roll using dir RCS XXXXXXXXXXXXXXXXXXXXXXXXXXXXXXXXXXXXX</p>	1	<p>Since a failure causing abnormal TVC and RCS attitude control is not a failed-on jet, RCS disabling should be done with MAN ATT switch to ACCEL CMD rather than AUTO RCS switches - OFF, thereby providing automatic RCS control for reorientation.</p> <p>Guarded.</p> <p>Lever lock.</p> <p>Guarded.</p>
		8	

SCS/SPS THRUSTING

12.3.1

NORMAL BACKUP

APOLLO-SOYUZ TEST PROJECT (ASTP)
OPERATIONS HANDBOOK

STA/T STEP	PROCEDURE	PANEL	REMARKS
AC 16	Mon for SPS eng cutoff cue ΔV ind - goes through -0.1 &/or EVNT T/P ind - 59:59 (-) thrust duration ΔV THRUST (2) - OFF SPS THRUST - MCPM SPS THRUST lt - out For postorbit change free drift MAN ATT (3) - ACCEL CMD Report eng cutoff Pc = 0	1	For suspected ΔV indicator failures, utilize Event Timer to terminate SPS thrust manually. Timer normally counts down from 59:59. Guarded. Lever lock.
DP	SPS INJ VLV ind (4) - CLOSE SPS He VLV tb (both) - bp	3	Barber pole indicates helium isolation valves closed.
AC	17 Set controls after tailoff DC IND sel - SM SOURCE 3	1	Decrease verifies gimbal motor shutdown. 6.1.1, note 12.
DP	DC AMPS ind - mon for amps decr after each No. 2 gmb1 mot shutdown GMEL MOT P2 & Y2 - OFF	3	Decrease verifies gimbal motor shutdown.
AC	DC IND sel - SM SOURCE 1 or 2	1	
DP	DC AMPS ind - mon for amps decr after each No. 1 gmb1 mot shutdown GMEL MOT P1 & Y1 - OFF	3	
AC	DC IND sel - MTA	1	
DP	EMS MODE - STBY	3	
AC	If orb change PCM BIT RATE - LO	1	6.1.1, note 10.
DP	Rcd ΔV ind	3	
AC	TVC SERVO PWP (both) - OFF	7	

SCS/SPS THRUSTING

**APOLLO-SOYUZ TEST PROJECT (ASTP)
OPERATIONS HANDBOOK**

STA/T STEP	PROCEDURE	PANEL	REMARKS
AC	If orb change cb SPS PITCH 1 BAT A - open cb SPS YAW 1 BAT A - open If deorbit cb SPS PITCH (both) - open cb SPS YAW (both) - open AITT DBD - MAX THC - LOCKED If deorbit TAPE RCDR FWD - off (ctr) If orb change RHC (both) - LOCKED RHC PWR DIR (both) - OFF (To re-zero registers, V32E)	8 1 3	
DP		2	Provides capability to monitor another burn without going through ROO.
AC, CP AC CP	18 PRO (exit P47) 19 FL V37 Key XXE If deorbit Go to CM/SM Sep: 14.2		When P47 termination desired.
CP	20 If orb change MN BUS TIE (2) - OFF	5	

12.3.1

SCS/SPS THRUSTING

NORMAL BACKUP

APOLLO-SOYUZ TEST PROJECT (ASTP)
OPERATIONS HANDBOOK

STA/T STEP	PROCEDURE	PANEL	REMARKS
DP	<pre> XXX X If MW BUS TIE fail prior to thrust Leave MW BUS TIE BAT B/C(A/C - on (up) Go to EPS Malf, Pwr Distr, SSR-2 reconfig for subsequent main bus ties XXXXXXXXXXXXXXXXXXXXXXXXXXXXXXXXXXXXX X </pre>	5	<p>Circuit breakers used to reconfigure for subsequent bat bus operation and battery charging procedures in place of opening (known) good main bus tie motor switches. Malfunction procedures are to be found in Flight Data File (FDF).</p>
AC	<pre> EMS FUNC - OFF Charge bats, 5.3.5 </pre>	1	

SCS/SPS THPUSITING

APOLLO-SOYUZ TEST PROJECT (ASTP)
OPERATIONS HANDBOOK

STA/T STEP	PROCEDURE	PANEL	REMARKS
12.3.2	<u>SCS/SM RCS Thrusting</u> CMC - on (desired), 8.1.3 ISS - on & orient known (desired), 8.1.3 & sec 13 SCS - on (req), 8.4.2 Veh Prep (req), 12.1		CMC and ISS on, and orientation known, necessary for P47 monitor.
CP	1 Key V37E 00E	2	P00 updates state vector periodically.
	2 Establish Tot Att disp, 7.2.5		
	3 Sel desired Att Cont, 7.1 Mnvr to thrust att		All RCS channels required for 3-axis thrusting.
	4 Establish SCS Att Hold, 7.1.4		Limit cycle, max deadband and low rate should be selected for propellant conservation until prior to thrusting.
-05:00 AC	5 Check boresight star		EMS can monitor only Xsc axis thrusting.
	6 For X-axis thrust If orb change ΔV Test & Null Bias Check, 7.6.1		For deorbit thrust, check accomplished during EMS Entry Test, 14.1.3, if desired.
	ΔV Setup, 7.6.2		Set to ΔV obtained from charts, P30, and/or STDN.
CP	7 If P47 for thrust monitor Key V37E 47E Poss PROG alarm (8.1.16)		G&N monitoring highly desirable, but not required. Refer to 8.1.6 for P47 description. R02.

SCS/SM RCS THRUSTING

12.3.2

NORMAL BACKUP

APOLLO-SOYUZ TEST PROJECT (ASTP)
OPERATIONS HANDBOOK

STA/T STEP	PROCEDURE	PANEL	REMARKS
CP	FL V16 N83 ΔVX, Y, Z (cont)	2	
	If desired Key N62E		
	VI		Inertial velocity.
	H dot		Altitude rate.
	H pad		Altitude above launch pad radius.
	XXXX.X FPS		
	XXXX.X FPS		
	XXXX.X NM		
	KEY REL (to return to N63)		
-00:30			
AC,			
CP	8 RHC (both) - ARMED	1	
AC	THC - ARMED		
	ATT DBD - MIN		
	LIM CYCLE - OFF		
DP	UP TLM CMD - RSET then NORM	3	
	PCM BIT RATE - HI		
	TAPE RCDR FWD - FWD		
AC	EMS MODE - NORM	1	6.1.1.1, note 10.
00:00			
	9 Perform thrust by manually nulling ΔV ind		
CP	If PSM deorbit, mon SM RCS QTY ind	2	
	If < $\frac{1}{2}$		
	PRO (exit P47)		
AC	EMS MODE - STBY	1	
CP	Rcd ΔV ind		
	SM RCS PSM PRPLNT (4) - CLOSE		
	SM RCS PSM PRPLNT tb (4) - bp	2	

SCS/SM RCS THRUSTING

APOLLO-SOYUZ TEST PROJECT (ASTP)
OPERATIONS HANDBOOK

STA/T STEP	PROCEDURE	PANEL	REMARKS
AC, DP, AC	SM RCS PSM He - CLOSE PSM He tb - bp SM RCS QUAD He (4) - OPEN SM RCS QUAD He tb (4) - gray SM RCS QUAD PRELNT (4) - OPEN SM RCS QUAD PRELNT tb (8) - gray Return to 1	1 3 1	6.1.1, note 10.
AC, DP, AC, DP, CP	10 EMS MODE - STBY PCM BIT RATE - LO Rcd ΔV compnts If orb change EMS FUNC - OFF RHC (both) - LOCKED THC - neut, LOCKED If deorbit TAPE RCDR FWD - off (ctr) (To re-zero registers, V32E)	3 2	Provides capability to monitor another burn without going through R00.
	11 PRO (exit P47)		R00 turns off average G.
	12 FL V37 Key XXE		
	13 If deorbit Go to CM/SM Sep, 14.2		

SCS/SM RCS THRUSTING

12.3.2

NORMAL/BACKUP

APOLLO-SOYUZ TEST PROJECT (ASTP)
OPERATIONS HANDBOOK

STA/T STEP	PROCEDURE	PANEL	REMARKS
12.3.3	SCS Hybrid Deorbit Thrusting		This procedure can be utilized for a pure CM RCS deorbit by omitting steps 10 and 11.
	CMC - on (desired), 8.1.3 ISS - on & orient known (desired), 8.1.3 & sec 13 SCS - on (req), 8.4.2 Veh Prep (req), 12.1		CMC and ISS on, and orientation known, necessary for P47 monitor.
CP	1 Key 737E 00E	2	POO updates state vector periodically.
2	Establish Tot Att disp, 7.2.5		Thrusting attitude for SM RCS portion of hybrid burn is nominally a retrograde +X translation with heads down and BEF.
3	Sel desired Att Cont, 7.1		Limit cycle, maximum deadband, and low rate should be selected for propellant conservation until prior to thrusting.
4	Mnvr to thrust att R ___ °, P ___ °, Y ___ °		Prepares for battery preloading prior to CM/SM separation and verifies batteries transferred to main buses.
5	Configure & preload bats		Assumes reconfiguration BAT A(B) and BAT C to MVA(E). Cb MN A(B) BAT C closed in Deorbit and Entry Vehicle Preparation, 14.1.
DP	<p style="text-align: center;"><u>CAUTION</u></p> If either bat bus A(B) current fails to incr after cycling MN BUS TIE sws, configure bats to main buses using cb BAT BUS A(B) BAT C.	275	

SCS HYBRID DEORBIT THRUSTING

APOLLO-BOYUZ TEST PROJECT (ASTP)
OPERATIONS HANDBOOK

STA/T STEP	PROCEDURE	PANEL	REMARKS
CP -10:00	MN BUS TIE BAT A/C - on (up) Verify bat bus A current incr &/or bat voltage decr MN BUS TIE BAT B/C - on (up) Verify bat bus B current incr &/or bat voltage decr	5	Verification of current increase for appropriate battery bus via DC AMPS indicator (panel 3) confirms successful operation of main bus tie motor switches. MN BUS TIE BAT A/C and B/C switches at on provide two batteries on line if cb MNA & B BAT C (2) - open, or three batteries on line for deorbit and entry if cbs closed (panel 275).
-05:00 AC	6 Check boresight star		
7	For X-axis thrust AV Setup, 7.6.2		If G&N inoperative, X axis only direction ΔV can be measured.
CP	8 If P47 for thrust monitor Key V37E 47E	2	G&N monitoring desirable but not required. Refer to 8.1.6 for P47 description.
	FL V16 N83 AVX, Y, Z (cont)		R02.
	Poss PROG alarm (8.1.16)		
	If desired Key N62E VI H dot H pad		Inertial velocity. Altitude rate. Altitude above launch pad radius.
	KEY REL (to return to N83)		

12.3.3

SCS HYBRID DEORBIT THRUSTING

NORMAL BACKUP

APOLLO-SOYUZ TEST PROJECT (ASTP)
OPERATIONS HANDBOOK

STA/T STEP	PROCEDURE	PANEL	REMARKS
-00:30 AC, CP AC	9 RHC (both) - ARMED THC - ARMED ATT DBD - MIN LIM CYCLE - OFF UP TIM CMD - RSET then NORM PCM BIT RATE - HI TAPE RC DR FWD - FWD EMS MODE - NORM	2 1 3	
00:00 AC	10 Perform SM RCS thrust Mon ΔV ind or EVNT TMR ind	1	6.1.1.1, note 10.
DP	11 SM RCS thrust complete EMS MODE - STBY PCM BIT RATE - LO Rcd ΔV ind, EVNT TMR ind	3	6.1.1.1, note 10.
	12 Sel SCS Att Cont mode, 7.1		Separation at SM deorbit attitude saves time. Only one minute allowed between burns.
	13 Perform Sep, 14.2		
	14 Mvr to CM RCS deorbit att R <u> </u> , P <u> </u> , Y <u> </u> Verify using external visual cues MAN ATT ROLL, YAW - RATE CMD MAN ATT PITCH - ACCEL CMD RATE - HI FDAI SCALE - 5/5	2 1	Both CM RCS systems should be enabled. CM RCS portion completed with +X axis ≈70° below velocity vector (apex down and forward); ≈110° +pitch maneuver from heads down, BEF, SM RCS portion of deorbit.

SCS HYBRID DEORBIT THRUSTING

APOLLO-SOYUZ TEST PROJECT (ASTP)
OPERATIONS HANDBOOK

STA/T STEP	PROCEDURE	PANEL	REMARKS
AC 15	EVNT TMR ind - SM RCS C/O +2 min EVS MODE - NORM	1	Two minutes after SM RCS cutoff, start CM RCS burn. 6.1.1, note 10.
CP	RHC 1 - contin -pitch	2	Negative pitch jets have ≈ 25 to 30% less authority than positive jets because of jet location and thrust direction relative to CM c.g.
AC	RHC 2 - pulse +pitch to maintain att in 3 axes XXXXXXXXXXXXXXXXXXXXXXXXXXXXXXXXXXXXX X If only 1 RHC Pulse RHC + & - 5° from pitch retro att, maintaining rates <3°/sec XXXXXXXXXXXXXXXXXXXXXXXXXXXXXXXXXXXXX X	1	ΔV indicator cutoff cue must be adjusted to account for EMS sensing axis (along X) being reversed from SM RCS burn and biased off $\approx 70^\circ$ from CM RCS velocity vector. ($\Delta V_{ems} = \Delta V_{cm} \cos 70^\circ$).
16	Mon ΔV ind or EVNT TMR ind for req value		6.1.1, note 10.
17	Term CM RCS deorbit burn MAN ATT (3) - RATE CMD or ACCEL CMD EMS MODE - STBY Rcd ΔV ind THC - LOCKED		Electrically isolates system 2 for entry. If a problem develops in system 1, disable affected channel and use direct RCS control.
18	Set up for CM RCS Sys 1 AUTO RCS A/C ROLL (4) - OFF AUTO RCS CM 1 (6) - MNA or MNB AUTO RCS CM 2 (6) - OFF	8	
CP 19	PRO (exit P47)	2	
20	FL V37 Key XXE Go to SCS Entry, 14.4		

SCS HYBRID DEORBIT THRUSTING

12.3.3

NORMAL BACKUP

APOLLO-SOYUZ TEST PROJECT (ASTP)
OPERATIONS HANDBOOK

STA/T STEP	PROCEDURE	PANEL	REMARKS
13.0	ALIGNMENTS		For general G&C operating data, refer to operating notes, 6.1.
13.1	G&N ALIGNMENTS		Computes matrix describing relative orientation between CSM and Soyuz. Option 2 may not be usable if Soyuz does not have a star tracker.
13.1.1	<u>(P50) Soyuz Orientation Determination</u>		Options 1 and 2.
CMC	- on (req), 8.1.3		Provides total attitude monitoring and attitude control capability. Minimum impulse control using RHC available (SCS & G&N) for sighting mark target alignment.
ISS	- on & orient known (req), 8.1.3 & sec 13		Required for control and display functions if SCS - on option not selected.
SCS	- on (desired), 8.4.2		Options 1 and 2.
AC	CMC ATT - IMU (verify) LOGIC 2/3 PWR - on (up)	1 7	Allows maneuvering, and provides inertial stability of CSM to ensure accuracy of alignments.
Opt	- on (req), 8.1.4		Options 1 and 2.
Att Cont	(req), 7.1		Assumes Soyuz has a star tracker.
Soyuz	- solar inertial (req)		Options 1 and 2.
Soyuz	star tracker - locked on celestial body (req)		Option 2. Assumes Soyuz has a star tracker.
CP	1 Key V37E 50E FL V04 N06 00012 (ref option) 0000X (desired option)		CMC initializes R2 = 00001.

(P50) SOYUZ ORIENTATION DETERMINATION

13.1.1

NORMAL BACKUP

APOLLO-SOYUZ TEST PROJECT (ASTP)
OPERATIONS HANDBOOK

STA/T STEP	PROCEDURE	PANEL	REMARKS
CP	<p>(X = 1, 2, or 3)</p> <p>Accept PRO Option 1 or 2, go to 2 Option 3, go to 7 Reject Key V22E Load desired option</p> <p>Poss PROG alarm (R53 - Sighting Mark Routine)</p> <p>2 FL V51 (please mrk) MARK</p> <p>If option 2 Record star tkr angles at time of MARK for input to N14</p> <p>To terminate Key V37E XXE</p> <p>or key V34E FL V37 Key XXE</p>	<p>2,140</p> <p>122</p> <p>2,140</p>	<p>Reference options are as follows:</p> <p>R2 = 00001 - Soyuz sun sensor, IMU 00002 - IMU, Soyuz sun sensor & star tracker 00003 - Soyuz angles from independent source</p> <p>CMC computes present NB to Soyuz matrix as desired IMU orientation.</p> <p>R02 (8.1.15).</p>

(P50) SOYUZ ORIENTATION DETERMINATION

APOLLO-SOYUZ TEST PROJECT (ASTP)
OPERATIONS HANDBOOK

STA/T STEP	PROCEDURE	PANEL	REMARKS
CP	<p>Poss PROG alarm Key V05 N09E (to verify alarm) 31211 (illegal interrupt of ext verb)</p> <p>When mrking complete Reselect ext verb</p> <p>3 FL V50 N25 00016 (term mrks)</p> <p>Accept PRO Opt 1, go to 7 Opt 2, go to 4 Reject MARK REJ, return to 2</p> <p>4 FL V01 N71 Trgt code OOEDE</p> <p>Accept PRO</p> <p>Poss OPR ERR Recycles disp</p> <p>Reject Key V21E Load desired data</p>	<p>2,140</p>	<p>Alarm generated if mark system busy or if extended verb active.</p> <p>Due to coding, noun and R1 not blanked on recycle.</p> <p>C - Source of sighting data 0 - CSM optics 1 - Soyuz sun sensor 2 - Soyuz star tracker</p> <p>DE - Target (celestial body) codes: 00 - Planet (any planet except earth) 01 to 45 - Star 46 - Sun 47 - Earth</p> <p>Target code negative, >47 or if C = 1 and CDE ≠ 146.</p>

13.1.1

(P50) SOYUZ ORIENTATION DETERMINATION

NORMAL BACKUP

APOLLO-SOYUZ TEST PROJECT (ASTP)
OPERATIONS HANDBOOK

STA/T STEP	PROCEDURE	PANEL	REMARKS
CP 5	FL V06 N14 (tracker angles) OGA XXXXX. ARC MIN IGA XXXXX. ARC MIN Poss OPR ERR (recycles N14) Accept PRO Reject Key V24E Load desired tracker angles	2,140	Tracker azimuth. Tracker elevation. If N14 (R1 or R2) >180°.
6	FL V06 N88 (planet only) X, Y, Z .XXXXX Accept PRO Reject Key V25E Load desired data		This flash will occur only if marks were made on a planet. X, Y, Z - components of planet unit position vector at present time. Use on-board tables to determine planet position vector at present time.
7	FL V06 N23 R, P, Y (NB to Soyuz ang) XXX.XX DEG Accept PRO Reject Key V25E Load desired data		Gimbal angles based upon CSM body axes and desired orientation.
8	FL V37 Key XXE		
9	Opt Pwr Down, 8.1.4		

(P50) SOYUZ ORIENTATION DETERMINATION

APOLLO-SOYUZ TEST PROJECT (ASTP)
OPERATIONS HANDBOOK

STA/T STEP	PROCEDURE	PANEL	REMARKS
13.1.2	(P51/P53) <u>IMU Orientation Determination</u>		(P51) IMU Orientation Determination defines inertial orientation of IMU using optics, Soyuz sun sensor, or star tracker. (P53) Alternate LOS IMU Orientation Determination defines inertial orientation of IMU using backup optical device (COAS), Soyuz sun sensor, or star tracker. P53 may also be used with failed optics or MARK pb.
	CMC - on (req), 8.1.3		Provides total attitude monitoring and attitude control capability. Minimum impulse control using RHC available (SCS & G&N) for sighting mark target alignment.
	ISS - on (req), 8.1.3		If Soyuz sun sensor or star tracker are to be used as source of sighting data.
	SCS - on (desired), 8.4.2		If valid transformation not previously established via P50.
	If Soyuz or star tkr		Required for control and display functions if SCS - on option not selected.
	P50 - completed	1	Optics required for P51; COAS used for P53.
	Soyuz - solar inertial (req)	7	Allows maneuvering, and provides inertial stability of CSM to ensure accuracy of alignments.
	CMC ATT - IMU (verify)		Both ISS and GDC attitude displays recommended for monitoring of IMU coarse align and SC motion.
	LOGIC 2/3 PWR - on (up)		
	Opt - on (req, P51), 8.1.4		
	COAS - calib (req, P53), 13.1.8		
	Att Cont (req), 7.1		
	Total Att Disp (req), 7.2.5		

13.1.2

(P51, P53) IMU ORIENTATION DETERMINATION

NORMAL BACKUP

APOLLO-SOYUZ TEST PROJECT (ASTP)
OPERATIONS HANDBOOK

STA/T STEP	PROCEDURE	PANEL	REMARKS
CP 1	Key V37E 51E/53E	2,140	R02 not entered in P51/P53.
	Poss PROG alarm FL V37 Key V05 N09E (to verify alarm) 00210 (ISS not on) Perform ISS turnon Key 51E/53E		
2	FL V50 N25 00015 (trgt acq)	2,140	Targets (celestial bodies).
	a. Desired att cont mode, 7.1 Mnvtr to acq tgts, if necessary PRO If P51 go to 3 If P53 go to 4		V16 N20 may be keyed in to monitor for impending gimbal lock if operating from LEB where no FDAI available.
	or b. To coarse align IMU to SC axes ENTER (when att acpt) V41 N22 (coarse align) R, P, Y 000.00 DEG NO ATT lt - on, then out Recycle: 2 (R53, Sighting Mark Routine)		Time and RCS fuel may be saved and subsequent IMU alignment decisions greatly simplified if IMU left inertially stabilized as close as possible to orientation required for future CMC programs.
3	FL V51 (please mrk) OPT ZERO - OFF OPT MODE - MAN	122	Not necessary for Soyuz sun sensor.

(P51/P53) IMU ORIENTATION DETERMINATION

APOLLO-SOYUZ TEST PROJECT (ASTP)
OPERATIONS HANDBOOK

STA/T STEP	PROCEDURE	PANEL	REMARKS
CP	Ctr trgt in SXT MARK (on trgt), go to 6 To terminate Key V37E XXE or Key V34E FL V37 Key XXE	Poss PROG alarm 2,140 Key V05 N09E (to verify alarm) 31211 (illegal interrupt of ext verb) When mrking complete Reselect ext verb (R56, Alternate LOS Sighting Mark Routine)	SCT may be used if reduced accuracy acceptable. MARK REL with no marks produces 00110 alarm. PRO recycles FLV51. If star tracker used, record star tracker angles at time of MARK for input to N14.
			Alarm generated if mark system busy or if extended verb active.
			To perform sighting marks using COAS.
			Values obtained from COAS Calibration, 13.1.1.8. Nominal SA and TA for COAS sightings are: SA - 000.00 DEG TA - 57.470 DEG

13.1.2

(P51/P53) IMU ORIENTATION DETERMINATION

NORMAL BACKUP

APOLLO-SOYUZ TEST PROJECT (ASTP)
OPERATIONS HANDBOOK

STA/T STEP	PROCEDURE	PANEL	REMARKS
CP 5	FL V53 (please mrk) RHC - ctr trgt in COAS reticle ENTR, go to 6		SCS minimum impulse mode is recommended. CMC interprets ENTR as a mark. An inadvertent PRO instead of ENTR will recycle FL V53. If star tracker used, record star tracker angles at time of MARK for input to N14.
6	FL V50 N25 00016 (term mrks) Accept PRO Reject If P51, MARK REJ pb - push Return to 3	2,140 122	An unsatisfactory mark may be rejected by pressing MARK REJ pushbutton (P51) or ENTR (P53) anytime prior to terminating marking sequence. In P51, possible program alarms if marks rejected without prior marks or if surplus marks made. In P51, due to coding, noun and R1 not blanked on recycle.
7	FL V01 N71 Trgt code Accept PRO	If P53, ENTR, return to 5 2,140	CMC interprets ENTR as a mark reject.
	OOCDE		C - Source of sighting data 0 - CSM optics 1 - Soyuz sun sensor 2 - Soyuz star tracker
			DE target (celestial body) codes: 00 - Planet (any planet except Earth) 01 to 45 - Star 46 - Sun 47 - Earth

(P51/P53) IMU ORIENTATION DETERMINATION

APOLLO-SOYUZ TEST PROJECT (ASTP)
OPERATIONS HANDBOOK

STA/T STEP	PROCEDURE	PANEL	REMARKS
CP	<p>Poss OPR ERR Recycles disp</p> <p>Reject Key V21E Load trgt code</p> <p>If C = 0 or 1 & DE ≠ 00 For trgt 2 P51, return to 3 P53, return to 4</p> <p>After 2nd pass Go to 10</p> <p>If C = 0 or 1 & DE = 0, go to 9</p> <p>If C = 2, go to 8</p>		<p>Target code negative, >47, or C = 1 & CDE ≠ 146.</p>
8	<p>FL V06 N14 (tracker angles)</p> <p>OGA XXXXX. ARC MIN IGA XXXXX. ARC MIN</p> <p>Accept FRO Reject Key V24E Load desired tracker angles</p> <p>For trgt 2 (DE ≠ 00) Return to 3 After 2nd pass, go to 10</p>	<p>2,140</p>	

13.1.2

(P51/P53) IMU ORIENTATION DETERMINATION

NORMAL BACKUP

APOLLO-SOYUZ TEST PROJECT (ASTP)
OPERATIONS HANDBOOK

STA/T STEP	PROCEDURE	PANEL	REMARKS
CP 9	FL V06 N88 (planet only) X, Y, Z .XXXXX Accept PRO Reject Key V25E Load desired data For trgt 2 P51, return to 3 P53, return to 4 (R54, Sighting Data Display Routine)		This flash will occur only if marks were made on a planet. X, Y, Z - components of planet unit position vector at present time. Use on-board tables to determine planet position vector at present time.
10	FL V06 N05 Sighting angle diff Sighting angle Accept PRO Reject Key V32E, return to 2	2,140	Tests accuracy of pair of target sightings. CMC calculates and stores IMU orientation as REFSMAT.
11	FL V37 Key XXE		ROO.
12	If P51 and no P52 Opt Pwr Down, 8.1.1.4		

(P51/P53) IMU ORIENTATION DETERMINATION

APOLLO-SOYUZ TEST PROJECT (ASTP)
OPERATIONS HANDBOOK

STA/T STEP	PROCEDURE	PANEL	REMARKS
13.1.1.3	(P52/P54) IMU Realign		<p>(P52) IMU Realign, and (P54) Alternate LOS IMU Realign, aligns IMU from known orientation to one of three orientations selected by crew. Sightings made on two targets (celestial bodies) with optics, Soyuz sun sensor, or star tracker in P52, or with COAS, Soyuz sun sensor, or star tracker in P54. Provides option for automatically pulse torquing gyros to prevent gimbal lock problem during plane change burn (NPC sequence).</p> <p>Orientation options available are:</p> <ul style="list-style-type: none"> o Preferred o Nominal o REFSMMAT <p>Provides total attitude monitoring and attitude control capability. Minimum impulse control using RHC available (SCS & G&N) for sighting mark target alignment.</p> <p>If Soyuz sun sensor or star tracker are to be used as source of sighting data.</p> <p>If valid transformation not previously established via P50.</p> <p>Required for control and display functions if SCS - on option not selected.</p> <p>Optics required for P52; COAS used for P54.</p>
13.1.1.3	<p>CMC - on (req), 8.1.1.3 ISS - on & orient known (req), 8.1.1.3 & sec 13 SCS - on (desired), 8.4.2</p> <p>If Soyuz or star tkr</p> <p>P50 - completed ATM - solar inertial (req)</p> <p>CDR CMC ATT - IMU (verify) LOGIC 2/3 PWR - on (up)</p> <p>Optics - on (req, P52), 8.1.1.4 COAS - calib (req, P54), 13.1.1.8</p>	<p>1 7</p>	

13.1.1.3 (P52/P54) IMU REALIGN

NORMAL BACKUP

APOLLO-SOYUZ TEST PROJECT (ASTP)
OPERATIONS HANDBOOK

STA/T STEP	PROCEDURE	PANEL	REMARKS
AC	Att Cont (req), 7.1 ZAP - Load & activate (req), 8.2.1 or 2 Tot Att Disp (req), 7.2.5		Allows maneuvering, and provides inertial stability of CCM to ensure accuracy of alignments. R03 or R04. Both ISS and GDC attitude displays recommended for monitoring of IMU coarse align and SC motion.
CP	1 IF MINKEY auto call Go to 4 or Key V37E 52E/54E Go to 2 Poss PROG alarm	2,140	P52 automatically called by MINKFY controller for pulse torquing during NPC sequence. R02 (8.1.15). If preferred orientation defined, R2 = 00001. Otherwise R2 = 00003 (REFSMAT alignment). Options available are: 00001 - Preferred (operator ensures preferred orientation defined) 00002 - Nominal 00003 - REFSMAT
2	FL V06 N34 Option code Option Accept PRO Reject Key VC2E Load desired option		GET align - Time at which nominal orientation defined. Display initially 0, 0, 0. If this value accepted, nominal orientation will be defined for GET align automatically selected as present time.
3	FL V06 N34 GET align a. If 00001, go to 4 or b. If 00002, go to 3 or c. If 00003, go to 8		COXX. HRS OOOX. MIN OXX.XX SEC

(P52/P54) IMU ALIGN

APOLLO-SOYUZ TEST PROJECT (ASTP)
OPERATIONS HANDBOOK

STA/T STEP	PROCEDURE	PANEL	REMARKS
CP	<p>Accept PRO</p> <p>Reject Key V25E Load desired GET align</p> <p>4 FL V06 N22 R, P, Y XXX.XX DEG</p> <p>Accept PRO, go to 6 or If P52 plane change PRO, go to 5</p> <p>Reject Desired att control mode, 7.1 Mnvr SC Key V32E</p> <p>or Key V37E XXE Exit P52/P54</p> <p>5 FL V50 N25 00020 (perform NPC torquing)</p> <p>Accept CMC MODE - FREE</p> <p>PRO</p> <p>V16 N20 (present gmb1 angles) R, P, Y XXX.XX DEG</p>	2,140	<p>Occurs when P52 automatically called for plane change torquing.</p> <p>To obtain acceptable MGA. V32E recycles to update gimbal angle display.</p> <p>Allows option to bypass pulse torquing.</p> <p>Prevents Jet firing (SC rotation) during gyro torquing.</p> <p>If PRO (pulse torquing) done prior to burn, must key PRO (to establish original alignment) after burn (PCFLAG is reset on exit from P52).</p>

13.1.3

(P52/P54) IMU REALIGN

NORMAL BACKUP

APOLLO-SOYUZ TEST PROJECT (ASTP)
OPERATIONS HANDBOOK

STA/T STEP	PROCEDURE	PANEL	REMARKS
CP	<p>NPC torque (preburn) exit P52, go to 12.2.1/12.2.2</p> <p>NPC torque (postburn) exit P52</p> <p>Reject ENTR</p> <p>Poss PROG alarm Key V05 N09E (to verify alarm)</p> <p>00402 (honor 2nd NPC torque request)</p> <p>KEY REL Recycle 5</p> <p>6 FL V50 N25 00013 (coarse align or pulse torque)</p> <p>Coarse align PRO, go to 7</p> <p>Pulse torque ENTR</p>	<p>2,140</p>	<p>CMC computes and torques gyros for NPC burn.</p> <p>Controller selects P41 for burn. Do not ENTR if first pulse torquing done and this is second pass.</p> <p>If first pulse torquing done, PCFLAG reset on exit from P52 making it imperative that second pulse torquing be done.</p> <p>Selects coarse align P50 and allows auto optics positioning.</p> <p>To pulse torque gyros. Bypasses P50 and auto optics positioning.</p>

(P52/P54) IMU REALIGN

APOLLO-SOYUZ TEST PROJECT (ASTP)
OPERATIONS HANDBOOK

STA/T STEP	PROCEDURE	PANEL	REMARKS
CP	<p>V16 N20 (present gmb1 angles) R, P, Y XXX.XX DEG</p> <p>Go to 21</p> <p>(R50, Coarse Align Routine)</p> <p>7 Verify coarse align complete NO ATT lt - on, then out Mon ball motion</p> <p>8 FL V50 N25 00015 (trgt acq)</p> <p>a. For CMC assist in sel Desired att cont mode, 7.1 Mnvr to acq trgt</p> <p>PRO</p>	2,140	<p>If it appears that IMU will be torqued into gimbal lock, maneuver should be performed to avoid condition. If SC CONT at CMC and CMC MODE at AUTO or HOLD, the DAP will maneuver vehicle to follow platform as it moves. If N93 used for display, scaling of N93 will not remain XX.XXX. Initially, N93 will display proper values; thereafter, R2, then R3, and finally R1 will diminish to zero as each gyro axis is torqued.</p> <p>During coarse alignment, if SC CONT at CMC and CMC MODE at AUTO or HOLD, DAP will maneuver vehicle to follow platform as it moves.</p> <p>If required gimbal angle change <1 degree, IMU will not be coarse-aligned.</p> <p>After target acquisition, SCS minimum impulse operation desirable for minimum fuel consumption and reduction of vehicle rates to minimum.</p> <p>CMC performs target selection routine. However, for P54, since primary optics are not being used, selected stars may not be acceptable for backup optics sightings.</p>

(P52/P54) IMU REALIGN

13.1.3

NORMAL/BACKUP

APOLLO-SOYUZ TEST PROJECT (ASTP)
OPERATIONS HANDBOOK

STA/T STEP	PROCEDURE	PANEL	REMARKS
CP	<p>Poss FL V05 N09 00405 (accept pair not avail) Mnvr until suitable trgt acq PRO, go to 9</p> <p>or Key V32E, recycle 8</p> <p>or b. To bypass CMC sel ENTR</p>	2,140	<p>Crew manually acquires target.</p>
9	<p>FL V01 N70 Trgt code OOCDE</p> <p>Accept If P52 & C = 0 OPT ZERO - OFF OPT MODE - as desired PRO</p> <p>If P52 & C ≠ 0 (or P54) PRO</p> <p>Poss CPR ERR Recycles disp</p> <p>Reject Key V21E Load desired code</p>	122 2,140	<p>C - Source of sighting data 0 - CSM optics 1 - Soyuz sun sensor 2 - Soyuz star tracker</p> <p>DE - Target (celestial body) codes: 00 - Planet (any planet except Earth) 01 to 45 - Star 46 - Sun 47 - Earth</p> <p>Target code negative, >47 or if C = 1 and CDE ≠ 146.</p>

(P52/P54) IMU REALIGN

APOLLO-SOYUZ TEST PROJECT (ASTP)
OPERATIONS HANDBOOK

STA/T STEP	PROCEDURE	PANEL	REMARKS
CP	For P52 If C = 0 & DE ≠ 00 & OPT MODE - CMC, go to 11 or OPT MODE - MAN, go to 12 If C ≠ 0 & DE ≠ 00, go to 12 For P54 If DE ≠ 00, go to 13 10 FL V06 N88 (planet only) X, Y, Z .XXXX	122 2,140	X, Y, Z - Components of planet unit position vector at present time.
	Accept If P52 PRO If OPT MODE - MAN or C ≠ 0, go to 12 If P54 PRO, go to 13 Reject Key V25E Load desired data (R52, Auto Optics Positioning)	122 2,140	Use on-board tables to determine planet position at present time. Points SLOS of optics at selected target.
11	V06 N92 (desired opt angles) SA XXX.XX DEG TA XX.XXX DEG Poss FL V05 N09 (2 sec priority) 00404 (TA >90°)		Optics will drive to acquire selected target. No display if R52 reselected after R53 called.

(P52/P54) IMU REALIGN

13.1.3

NORMAL/BACKUP

APOLLO-SOYUZ TEST PROJECT (ASTP)
OPERATIONS HANDBOOK

STA/T STEP	PROCEDURE	PANEL	REMARKS
CP	<p>a. Desired att cont mode, 7.1 Mnvr to reduce TA</p> <p>PRO</p> <p>or b. Key V34E FL V37 Key XXE</p> <p>If TA > 50° & < 90° Desired att cont mode, 7.1</p> <p>Mnvr to reduce TA</p> <p>When sighting mrks are desired OPT MODE - MAN (R53, Sighting Mark Routine)</p> <p>12 FL V51 (please mark) Ctr trgt in SXT</p> <p>MARK (on trgt), go to 15</p> <p>To terminate Key V37E XXE</p> <p>or Key V34E FL V37 Key XXE</p>	2,140	<p>If required optics angles not being displayed, key V16 N92E to obtain display.</p> <p>R00.</p> <p>If TA > 50° and < 90°, trunnion driven to upper limit (-49.7754°) and held at this angle.</p> <p>If required optics angles not being displayed, key V16 N92E to obtain display.</p> <p>Calls R53. To regain auto optics positioning, select OPT MODE - CMC (prior to completion of R53).</p> <p>SCT may be used if reduced accuracy acceptable.</p> <p>If star tracker used, record star tracker angles at time of MARK for input to N14.</p>

(P52/P54) IMU REALIGN

APOLLO-SOYUZ TEST PROJECT (ASTP)
OPERATIONS HANDBOOK

STA/T STEP	PROCEDURE	PANEL	REMARKS
CP	Poss PROG alarm Key V05 N09E (to verify alarm) 31211 (illegal interrupt of ext verb) When mrking complete Reselect ext verb (R56, Alternate LOS Sighting Mark Routine)	2,140	Alarm generated if mark system busy or if extended verb active. To perform sighting marks using COAS.
13	FL V06 N94 SA TA Accept PRC Reject Key V24E Load desired SA & TA	XXX.XX DEG XX.XXX DEG	Values obtained from COAS Calibration, 13.1.8. Nominal SA and TA for COAS sightings are: SA - 000.00 DEG TA - 57.470 DEG
14	FL V53 (please mrk) RHC - ctr trgt in COAS reticle ENTR		SCS minimum impulse mode recommended. CMC interprets ENTR as a mark. An inadvertent PRO instead of ENTR will recycle FL V53. If star tracker used, record star tracker angles at time of MARK for input to N14.
15	FL V50 N25 00016 (term mrks)		

13.1.3 (P52/P54) IMU REALIGN

NORMAL BACKUP

APOLLO-SOYUZ TEST PROJECT (ASTP)
OPERATIONS HANDBOOK

STA/T STEP	PROCEDURE	PANEL	REMARKS
CP	Accept PRO Reject If P52, MARK REJ pb - push, return to 12 If P54, ENTFR, return to 14 16 FL V01 N71 Trgt code OOCDE Accept PRO	2,140	An unsatisfactory mark may be rejected by keying MARK REJ pushbutton (P52) or ENTFR (P54) anytime prior to terminating marking sequence. In P52, possible program alarms if marks rejected without prior marks or if surplus marks made. In P52, due to coding, noun and R1 not blanked on recycle. C - Source of sighting data 0 - CSM optics 1 - Soyuz sun sensor 2 - Soyuz star tracker DE - Target (celestial body) codes: 00 - Planet (any planet except Earth) 01 to 45 - Star 46 - Sun 47 - Earth Target code negative, >47 or if C = 1 and CDE ≠ 146.
	Poss OPR ERR Recycles disp Reject Key V21E Load trgt code If C = 0 or 1 & DE ≠ 00 For trgt 2 Return to 9 If C = 2, go to 17		

(P52/P54) IMU REALIGN

APOLLO-SOYUZ TEST PROJECT (ASTP)
OPERATIONS HANDBOOK

STA/T STEP	PROCEDURE	PANEL	REMARKS
CP 17	FL V06 N14 (tracker angles) OGA XXXXX. ARC MIN IGA XXXXX. ARC MIN Accept PRO Reject Key V24E Load desired tracker angles For trgt 2 (DE # 00) Return to 9	2,140	
18	FL V06 N88 (planet only) X, Y, Z .XXXXX		This flash will occur only if marks are made on a planet. X, Y, Z - Components of planet unit position vector at present time. Use on-board tables to determine planet position vector at present time.
19	FL V06 N05 Sighting angle diff XXX.XX DEG Sighting angle XXX.XX DEG Accept PRO Reject Key V32E, go to 21		Test accuracy of pair of target sightings.

13.1.3

(P52/P54) IMU REALIGN

NORMAL BACKUP

APOLLO-SOYUZ TEST PROJECT (ASTP)
OPERATIONS HANDBOOK

STA/T STEP	PROCEDURE	PANEL	REMARKS
CP 20	(R55, Gyro Torquing Routine) FL V06 N93 (Δ gyro angles) X, Y, Z XX.XXX DEG	2,140	Calculates and displays gyro torquing angles for final (fine) alignment of inertial platform and to torque gyros. X, Y, Z Gyro - Angle through which each gyro must be torqued to obtain desired orientation. Once this step is complete, CMC will reset preferred orientation flag. If SC CONT at CMC and CMC MODE switch is at AUTO or HOLD during R55, DAP will maneuver CSM to follow platform as it moves. Pulse IRIGS through desired angle. Do not torque gyros.
21	Accept CMC MODE - FREE PRO (gyros torqued) Reject V32E, go to 21 or Key V37E 00E, go to 23		PRO repeats target sightings (R52 & R53) for P52; (R56) for P54; sighting data test (R54), and gyro torquing (R55) to verify accuracy of alignment.
22	FL V50 N25 00014 (fine align check) Accept PRO, return to 8 Reject EMTR		R00.
23	FL V37 Key XXE If P52 Opt Pwr Down, 8.1.4		

(P52/P54) IMU REALIGN

APOLLO-SOYUZ TEST PROJECT (ASTP)
OPERATIONS HANDBOOK

STA/T STEP	PROCEDURE	PANEL	REMARKS
13.1.4	<p>(P55) <u>Soyuz Star Tracker Gimbal Angle Program</u></p> <p>CMC - on (req), 8.1.3 ISS - on & orient known (req), 8.1.3 & sec 13 SCS - on (desired), 8.4.2</p>		<p>Computes and displays Soyuz star tracker gimbal angles required to acquire a specified star. This program may not be usable on ASTP if the Soyuz does not have a star tracker.</p>
Option 1.			<p>Provides total attitude monitoring and attitude control capability. Minimum impulse control using RHC available (SCS & G&N) for sighting mark target alignment.</p>
P50 - completed			<p>Operation of P55 assumes P50 previously selected to establish required relative orientation matrix.</p>
AC	<p>CMC ATT - IMU (verify) LOGIC 2/3 PWR - on (up)</p>	<p>1 7</p>	<p>Required for control and display functions if SCS - on option not selected.</p>
Opt - on (req), 8.1.4			<p>Option 2.</p>
Att Cont (req), 7.1			<p>Allows maneuvering, and provides inertial stability of CSM to ensure accuracy of alignments.</p>
CP	<p>Soyuz - solar inertial (req)</p> <p>1 Key V37E 55E 2 FL V04 N06 00013 (ref option) 0000X (desired option)</p>		<p>Option 2.</p> <p>CMC initializes R2 = 00001.</p>

13.1.4

(P55) SOYUZ STAR TRACKER GIMBAL ANGLE PROGRAM

NORMAL BACKUP

APOLLO-SOYUZ TEST PROJECT (ASTP)
OPERATIONS HANDBOOK

STA/T STEP	PROCEDURE	PANEL	REMARKS
CP	(X = 1 or 2)		Reference options are as follows:
	Accept PRO	2,140	R2 = 00001 - IMU.
	Option 1, go to 7		00002 - Optics and Soyuz sun sensor.
	Option 2, go to 3		
	Reject Key V22E		CMC initializes N70/N71 star code to 46 (sun).
	Load desired option		
	If option 1		
	Poss PROG alarm		R02 (8.1.15).
	(R53 - Sighting Mark Routine)		
	3 FL V51 (please mrk)	122	Required for centering target using OEC.
	OPT ZERO - OFF		SCT may be used if reduced accuracy acceptable.
	OPT MODE - MAN		
	Ctr trgt in SXT		
	MARK (on trgt)		MARK REJ with no marks produces 00110 alarm. PRO recycles FLV51.
	To terminate		
	Key V37E XXE	2,140	
	or Key V34E		
	FL V37		
	Key XXE		

(P55) SOYUZ STAR TRACKER GIMBAL ANGLE PROGRAM

APOLLO-SOYUZ TEST PROJECT (ASTP)
OPERATIONS HANDBOOK

STA/T STEP	PROCEDURE	PANEL	REMARKS
CP	Poss PROG alarm Key V05 N09E (to verify alarm) 31211 (illegal interrupt of ext verb)	2,140	Alarm generated if mark system busy or if extended verb active.
4	FL V50 N25 00016 (term mrks)		
	When mrking complete Reselect ext verb		
	Accept PRO Reject MARK REJ, return to 3		Due to coding, noun and R1 not blanked on recycle.
5	FL V01 N71 Trgt code OOCDE Accept PRO DE # 00, go to 7 C = 2, go to 9		CMC initializes C to 0 (optics) and DE to 46 (sun). C - Source of sighting data 0 - CSM optics 1 - Soyuz sun sensor (not significant for P55) 2 - Soyuz star tracker (not significant for P55)
	Poss OPR ERR Recycles disp		DE - Target (celestial body) codes: 00 - Planet (any planet except Earth) 01 to 45 - Star 46 - Sun 47 - Earth Target code negative, >47 or if C = 1 and CDE # 146.

13.1.1.1

(P55) SOYUZ STAR TRACKER GIMBAL ANGLE PROGRAM

NORMAL/BACKUP

APOLLO-SOYUZ TEST PROJECT (ASTP)
OPERATIONS HANDBOOK

STA/T STEP	PROCEDURE	PANEL	REMARKS
CP	Reject Key V21E Load trgt code 6 FL V06 N88 (planet only) X, Y, Z .XXXX	2,140	This flash will occur only if marks were made on a planet. X, Y, Z - Components of planet unit position vector at present time. Use on-board tables to determine planet position vector at present time. Source code C must be zero. Any non-zero digit turns on OPR ERR lt.
7	FL V01 N70 Trgt code 00CDE Accept PRO DE ≠ 00, go to 9 Reject Key V21E Load trgt code Poss PROG alarm Key V05 N09E (to verify alarm) 00107 (excessive tracker angles)		C - Source of sighting data 0 - CSM optics 1 - Soyuz sun sensor (not significant for P55) 2 - Soyuz star tracker (not significant for P55) DE - Target (celestial body) codes: 00 - Planet (any planet except Earth) 01 to 45 - Star 46 - Sun 47 - Earth Target code negative, >47 or C ≠ 0.
8	FL V06 N88 (planet only) X, Y, Z .XXXX Accept PRO Reject Key V25E Load desired data		

(P55) SOYUZ STAR TRACKER GENERAL ANGLE PROGRAM

APOLLO-SOYUZ TEST PROJECT (ASTP)
OPERATIONS HANDBOOK

STA/T STEP	PROCEDURE	PANEL	REMARKS
CP	Poss PROG alarm Key V05 N09E (to verify alarm) 00107 (excessive tracker angles)	2,140	
9	FL V06 N14 (tracker angles) OGA XXXXX. ARC MIN IGA XXXXX. ARC MIN		
	Accept PRO Reject Key V32E, return to 7		
10	FL V04 N19 OGA OSABC IGA OODEO		
	Accept PRO Reject Key V32E, return to 7		
11	FL V37 Key XXE		
12	Opt Pwr Down, 8.1.4		

Tracker azimuth:
 S - sign (0 = positive, 1 = negative)
 ABCDE - absolute value (octal equivalent of
 R1 of N14).

13.1.4 (P55) SOYUZ STAR TRACKER GIMBAL ANGLE PROGRAM

NORMAL BACKUP

APOLLO-SOYUZ TEST PROJECT (ASTP)
OPERATIONS HANDBOOK

STA/T STEP	PROCEDURE	PANEL	REMARKS
13.1.5	<u>(V40) Zero ICDU Extended Verb</u> CMC - on (req), 8.1.3 ISS - on (req), 8.1.3 CP 1 Key V40E NO ATT lt - OFF Wait 15 sec Poss OPR ERR Poss PROG alarm Exit routine Key V05 N09E (to verify alarm) 00206 (zero encode not allowed) Key V41 N20E, 13.1.6	2,140	<ul style="list-style-type: none"> o Ensures synchronization between ISS CDU counters and CDU counters in CMC. o Terminates IMU coarse align mode and enters fine align mode (inertial IMU). <p>If IMU stall routine in use.</p> <p>If ISS in coarse align mode with gimbal lock.</p>

(V40) ZERO ICDU EXTENDED VERB

APOLLO-SOYUZ TEST PROJECT (ASTP)
OPERATIONS HANDBOOK

STA/T STEP	PROCEDURE	PANEL	REMARKS
13.1.6	(V41 N20) Coarse Align ICDU <u>Extended Verb</u>		Coarse aligns IMU to gimbal angles specified by crew.
CMC	- on (req), 8.1.3		
ISS	- on (req), 8.1.3		
CP	1 Key V41 N20E	2,140	Occurs if another extended verb active.
	Poss OPR ERR Exit coarse align		
2	FL V21 N22 (new ICDU angles) R, P, Y XXX.XX DEG		Registers initially blank.
	Load desired angles		
	or Key V33E		6.1.3, note 3m.
	DSKY - V41		
	NO ATT lt - on		NO ATT lt will remain on even after gimbals have been driven to specified angles.
	Poss PROG alarm		
	Key V05 N09E (to verify alarm) 00211 (error >2°)		
	To recover from PROG alarm		
	Key V41 N20E		Present and specified gimbal angles may be compared by keying V16 N20E and V16 N22E. Alternate method is to key V62E (Mode 2) to display difference between N20 and N22 on FDAI error needles.
	Poss OPR ERR		
	Exit coarse align		If IMU stall routine in use.
3	To extinguish NO ATT lt & term coarse align		
	Key V40E		Zero ICDU extended verb, 13.1.5.
	Wait 15 sec		
	or V42E		Torque gyros extended verb, 8.3.2.

13.1.6

(V41 N20) COARSE ALIGN ICDU EXTENDED VERB

NORMAL BACKUP

APOLLO-SOYUZ TEST PROJECT (ASTP)
OPERATIONS HANDBOOK

STA/T STEP	PROCEDURE	PANEL	REMARKS
13.1.7	(V41 N91) Coarse Align OCDU <u>Extended Verb</u>		Drive optics to shaft and trunnion angles specified by crew. Not permitted from start of drive test until end of burn. (Ref note opposite 00117 alarm, step 3.)
CF	CMC - on (req), 8.1.3 Opt Pwr Up (req), 8.1.4		
1	Key V37E 00E	2,140	V41 N91 from P00 only.
2	OPT ZERO - OFF OPT MODE - CMC	122	
3	Key V41 N91E Poss OPR ERR Exit coarse align OCDUs Poss PFOG alarm Key V05 N09E (to verify alarm) 00115 (OPT MODE not CMC) OPT MODE - CMC or 00117 (V41 N91 not avail) Exit coarse align	2,140	Occurs if another extended verb active. OPR ERR lt on. This alarm code indicates that OCDUs are being used by TVC DAP or gimbal drive test and that this procedure cannot be performed. May occur from start of drive test until end of burn (not expected since V41 N91 is restricted to P00). Registers initially blank.
4	FL V21 N92 (new OCDU angles) SA TA Load desired SA & TA		6.1.3, note 3m. Key V16 N91E to monitor optics angles.
or	Key V33E		
5	DSKY - V41		
6	Opt Pwr Down, 8.1.4		

(V41 N91) COARSE ALIGN OCDU EXTENDED VERB

APOLLO-SOYUZ TEST PROJECT (ASTP)
OPERATIONS HANDBOOK

STA/T STEP	PROCEDURE	PANEL	REMARKS
13.1.8	<u>Inflight COAS Calibration</u>		
	CMC - on (req), 8.1.3 ISS - on & orient known (req), 8.1.3 & sec 13 SCS - on (req), 6.4.2 CMC ATT - IMU (verify) .05 G sw - OFF (verify) COAS installed COAS PWR - on (up) COAS filter installed (req)	1	Provides method for in-flight calibration of COAS (i.e., equivalent shaft and trunnion angles). Spare COAS light bulbs (2) are stowed in volume U3. When installing COAS on window mount, align (rotate COAS barrel to detent) as indicated by arrow on decal.
AC		15	6.1.1.1, note 15. Filter used to reduce glare of reticle image when sighting on low intensity targets.
CP	1 Opt Pwr Up, 8.1.1.4 2 Sel Tot Att Disp, 7.2.5 3 Key V37E 52E 4 FL V04 N06 Option code 00001 Option 0000X Sel REFSMMAT orient (V22E, 3E) PRO	2,140	R02 (8.1.15). If preferred alignment flag is set, R2 will display 00001. Otherwise, R2 will display 00003 (REFSMMAT alignment). Options available are: 00001 - Preferred (operator ensures preferred orientation defined) 00002 - Nominal 00003 - REFSMMAT

13.1.8

INFLIGHT COAS CALIBRATION

NORMAL BACKUP

APOLLO-SOYUZ TEST PROJECT (ASTP)
OPERATIONS HANDBOOK

STA/T STEP	PROCEDURE	PANEL	REMARKS
CP 5	FL V50 N25 00015 (trgt acq) Att Cont Mode, 7.1 Mnvr to acq trgt in COAS ENTR	2,140	Target (celestial bodies).
6	FL V01 N70 Trgt code 00CDE OPT ZERO - OFF OPT MODE - CMC Reject Key V21E Load trgt code of trgt centered in COAS Accept PRO	122 2,140	C - Source of sighting data 0 - CSM optics 1 - Soyuz sun sensor 2 - Soyuz star tracker DE - Target (celestial body) codes: 00 - Planet (any planet except Earth) 01 to 45 -- Star 46 - Sun 47 - Earth
7	FL V06 N88 (planet only) X, Y, Z .XXXX Accept PRO Reject Key V25E Load desired data		Target code negative, >47, or if C = 1 and CDE ≠ 146. X, Y, Z - Components of planet unit position vector at present time.

INFLIGHT COAS CALIBRATION

APOLLO-SOYUZ TEST PROJECT (ASTP)
OPERATIONS HANDBOOK

STA/T STEP	PROCEDURE	PANEL	REMARKS
CP 8	V06 N92 SA XXX.XX DEG TA XX.XXX DEG (R52, Auto Optics Positioning Routine) When trgt centered in COAS & SA & TA relatively constant Key VERB (to freeze disp) Accept Red SA & TA for use in P20/P53/P54 Reject KEY REL Repeat 8	2,140	Display will be updated every ≈0.5 second.
AC 9	Opt Pwr Down, 8.1.4 COAS PWR - OFF	15	
AC 10	Sel new prog		

INFLIGHT COAS CALIBRATION

13.1.8

NORMAL BACKUP

APOLLO-SOYUZ TEST PROJECT (ASTP)
OPERATIONS HANDBOOK

STA/T STEP	PROCEDURE	PANEL	REMARKS
13.2	SCS ALIGNMENTS		
13.2.1	Alternate SC Inertial Attitude Determination and GDC Alignment.		
AC	SCS - on (req), 8.4.2 CMC ATT - IMU (verify) .05 G sw - OFF (verify)	1	
1	Opt Pwr Up, 8.1.4		
2	Sel Tot Att, Att Err & Rate Disp for SCS, 7.2		If IMU off, only FDAI 1 need be powered or selected.
3	Sel SCS Att Hold/Rate Cmd, 7.1.4		For fuel conservation, max deadband preferred until stars obtained.
4	Obtain 2 stars in SCT Sel Opt Cont, 7.5.2 OHC - ctr star on P-line OHC - ctr star in FOV Hold star 1 in ctr of FOV Hold star 2 on R line	121	OHC - Optics hand control. Final adjustment required OPT COUPLING - DIRECT. Minimum impulse control can be used to allow positioning of stars on R line.
5	EMAG MODE (3) - RATE 2 ATT DBD - MIN EMAG MODE (3) - ATT 1/RATE 2	1	Stars must be kept aligned while EMAGs caged.
6	Read & rcd angles on trun & shft ind(s) & xmit with star data to STDN	121	

ALTERNATE SC INERTIAL ATTITUDE DETERMINATION AND GDC ALIGNMENT

APOLLO-SOYUZ TEST PROJECT (ASTP)
OPERATIONS HANDBOOK

STA/T STEP	PROCEDURE	PANEL	REMARKS
CP	7 Obtain inertial att values for ATT SET tv from STDN	121	
	8 Align GDC to STDN values, 7.3		
	9 Opt Pwr Down, 8.1.4		

13.2.1

ALTERNATE SC INERTIAL ATTITUDE DETERMINATION AND GDC ALIGNMENT

NORMAL BACKUP

APOLLO-SOYUZ TEST PROJECT (ASTP)
OPERATIONS HANDBOOK

STA/T STEP	PROCEDURE	PANEL	REMARKS
13.2.2	<u>Inplane GDC Alignment</u>		Provides method for aligning SCS attitude reference system in orbital plane (+Y axis of reference along <u>V x R</u>). This allows use of ORDEAL on FDAI 2 with IMU out of plane.
AC	CMC - on (req), 8.1.3 ISS - on & orient known (req), 8.1.3 & sec 13 SCS - on (req), 8.4.2 CMC ATT - IMU (verify)	1	
1	Sel Tot Att Disp, 7.2.5		
CP	FDAI SEL - 1/2 Key V37E 52E Poss PROG alarm	2,140	R02 (8.1.15).
3	FL V04 N06 Option code Option Select nom option Key V22E 2E	00001 0000X	Options available are: 00001 - Preferred (operator ensures preferred orientation defined) 00002 - Nominal 00003 - REFSMMAT
4	FL V06 N34 GET align	0000X. HRS 0000X. MIN 00X.XX SEC	GET align - Time at which vehicle position and velocity vectors selected to define IMU local vertical orientation.

INPLANE GDC ALIGNMENT

APOLLO-SOYUZ TEST PROJECT (ASTP)
OPERATIONS HANDBOOK

STA/T STEP	PROCEDURE	PANEL	REMARKS
CP	Key V25E Load present time plus 10 min	2,140	Selected to prevent drift between gimbal angle calculation and GDC alignment.
5	Establish Att Cont, 7.1 Damp veh rates		
	PRO		
6	FL VO6 N22 R. P, i XXX.XX DEG		IMU gimbal angles for desired IMU orientation at present SC attitude.
AC	7 ATT SEF tw - adj to Euler angles disp on DSKY	1	
8	Align GDC, 7.3		
9	Sel new program		

13.2.2

INPLANE GDC ALIGNMENT

NORMAL BACKUP

APOLLO-SOYUZ TEST PROJECT (ASTP)
OPERATIONS HANDBOOK

STA/T STEP	PROCEDURE	PANEL	REMARKS
13.2.3	<u>Backup GDC Alignment With COAS</u> SCS - on (req), 6.4.2 CMC - off or STBY (req)		Aligns GDC without IMU, CMC or optics.
AC	COAS - installed COAS PWR - on (up) .05 G sw - OFF (verify) CMC ATT - IMU (verify)	15 1	A more accurate alignment can be performed if COAS calibration procedure, 13.1.8, has been performed earlier and calibration information provided to STDN for use in computation of R, P and Y ALIGN. 6.1.1, note 15.
CP	1 Rcd following data from STDN GDC Align Values (step 2) R ALIGN ____, P ALIGN ____, Y ALIGN ____ Boresight star data (step 13) Boresight star SPA ____° SXP ____° Nav stars Prim star ____ (step 5) Sec star ____ (step 8) Star diff angle ____° (step 7)		SPA - Sigt pitch angle SXP - Star X position
AC	2 SCS att set for FDAI 1, 7.2.4 ATT SET tw - set R, P, Y ALIGN 3 Set reticle to 0° pitch		Star difference angle cannot exceed 35° since this is maximum COAS field of view in pitch.

BACKUP GDC ALIGNMENT WITH COAS

APOLLO-SOYUZ TEST PROJECT (ASTP)
OPERATIONS HANDBOOK

STA/T STEP	PROCEDURE	PANEL	REMARKS
AC	<p>4 Sel SCS att cont mode, 7.1</p> <p>5 Mnvr to posi ion prim star on crosshairs of COAS reticle</p> <p>6 Establish att hold with min P & Y dbd</p> <p>7 Pitch COAS reticle up Star Angle Diff value</p> <p>8 Roll SC to place sec star on pitch axis of COAS reticle</p> <p>9 Establish att hold with min roll dbd</p> <p>10 Repeat 3 through 9 as necessary</p> <p>11 Align GDC, 7.3 GDC ALIGN pb - push, when stars positioned, until err null on FDAI 1</p> <p>12 Mnvr to ΔV att ATT SET tw - set to ΔV att Mnvr Null errors on FDAI</p> <p>13 Perform Boresight Star ck</p> <p>14 COAS PWR - OFF</p>	<p>1</p> <p>15</p>	

13.2.3

BACKUP GDC ALIGNMENT WITH COAS

NORMAL BACKUP

APOLLO-SOYUZ TEST PROJECT (ASTP)
OPERATIONS HANDBOOK

STA/T STEP	PROCEDURE	PANEL	REMARKS
13.3	G&C ALIGNMENTS		
13.3.1	<u>Backup GDC and/or IMU Alignment</u>		Aligns GDC and/or IMU without CMC.
AC	SCS - on (req), 8.4.2 CMC - off or STBY (for step 3a) COAS installed COAS PMR - on (up) .05 G sw - OFF (verify) CMC ATT - IMU (verify)	15 1	6.1.1.1, note 15.
CF	1 Rcd following data from STDN GDC Align Values (step 8) R ALIGN ____, P ALIGN ____, Y ALIGN ____ SXTS data (step 10) SXTS ____° SHAFT ____° TRUN ____° Boresight star data (step 4) Boresight star ____ SPA ____° SXP ____° Nav stars (step 7) Prim star ____ (0° mark on R line of SCT reticle) Sec star ____ (R line)		SXTS - Sextant star. SPA - Sight pitch angle. SXP - Star X position. 0° and 0° allows SC to be rolled about boresight star in 7.

BACKUP GDC AND/OR IMU ALIGNMENT

APOLLO-SOYUZ TEST PROJECT (ASTP)
OPERATIONS HANDBOOK

STA/T STEP	PROCEDURE	PANEL	REMARKS
CP 2	ISS att set for FDAI 1, 7.2.4		
3	Cage IMU		This step is bypassed, if only GDC aligned.
	If IMU in stby IMU PWR - on (up) (IMU automatically cages)	100	Guarded. Occurs only if CMC off, or in STBY.
	If IMU powered up		
	a. IMU PWR - OFF Wait 5 min for gyros to run down IMU PWR - on (up)		Guarded.
AC or	b. ATT SET tw - set to 0°, 0°, 0° Mnvr SC to 0°, 0°, 0° & null FDAI 1 errors	1	Guarded.
	IMU CAGE - on (up) & hold until 11		IMU gimbal angles should be 0+5° before caging to avoid damaging gyros.
4	Sel desired SCS Att Cont Mode, 7.1, & mnvr to position boresight star in COAS		Guarded.
5	Opt Pwr Up, 8.1.4		
CP 6	Set opt to 0° shft & 352.5° trun, 7.5		0° shaft and 352.5° trunnion places 0° mark of SCT reticle along +Zsc axis.
	OPT PWR - OFF	100	Eliminates optics drift.

13.3.1

BACKUP GDC AND/OR IMU ALIGNMENT

NORMAL BACKUP

APOLLO-SOYUZ TEST PROJECT (ASTP)
OPERATIONS HANDBOOK

STA/T STEP	PROCEDURE	PANEL	REMARKS
CP	7 MnvR to position stars in SCT		Roll SC around boresight star to acquire navigation stars. After positioning primary star on 0° mark, SC may be yawed about this star to place secondary star on R line.
AC	8 Align GDC ATT SET tw - set to R, P, Y ALIGN ATT SET - GDC GDC ALIGN pb - push when stars positioned, until err null on FDAI 1	1	ELEC PWR - GDC/ECA (required for GDC ALIGN) satisfied by SCS Power Up, 8.4.2.
	9 MnvR to ΔV att ATT SET tw - set to ΔV att MnvR Null err on FDAI 1		
	10 Perform SXTS ck & adj SC att if necessary		With optics set to proper shaft and trunnion angles, and SC at ΔV attitude, specified star should appear in SXT.
	11 Uncage IMU IMU CAGE - on (up) and rel If 3b was used IMU CAGE - rel		This frees IMU at 0°, 0°, 0°. (For deorbit, GDC will be at 180°, 180°, 0°.)
	12 Opt Pwr Down, 8.1.4 COAS PWR - OFF	15	

BACKUP GDC AND/OR IMU ALIGNMENT

APOLLO-SOYUZ TEST PROJECT (ASTP)
OPERATIONS HANDBOOK

STA/T STEP	PROCEDURE	PANEL	REMARKS
14.0	ENTRY		For general G&C operating data, refer to operating notes, 6.1.
14.1	DEORBIT AND ENTRY VEHICLE PREPARATION (Proced in 14.1.1 thru 14.1.4 not designated as "req" are optional)		Vehicle preparation applies to any deorbit (SPS or RCS, pure or hybrid, whether G&N, SCS or manually controlled) and should be done prior to deorbit thrust to minimize crew workload between deorbit and entry.
14.1.1	<u>General System Management</u>		
CP 1	SEC EVAP H2O CONT - AUTO (verify)	382	
2	Obtain update from STDN		
DP 3	Configure TLM (req) TAPE RCDR FWD - off (ctr) PCM BIT RATE - HI UP TLM CMD - RSET, then NORM	3	After STDN dumps and rewinds tape recorder and returns DSE control to crew at last contact prior to deorbit, TAPE RCDR FWD switch placed to off (ctr) and PCM BIT RATE switch to HI.
AC 4	SECS logic check cb SECS ARM (2) - close cb ELS/CM-SM SEP (2) - close ELS LOGIC - on (up) ELS AUTO - AUTO After STDN AOS SECS LOGIC (2) - on (up) Report logic arm STDN confirm GO for PYRO ARM (as req) SECS LOGIC (2) - OFF cb SECS ARM (2) - open cb ELS/CM-SM SEP (2) - open ELS LOGIC - OFF ELS AUTO - MAN	8	

GENERAL SYSTEM MANAGEMENT

14.1.1

NORMAL BACKUP

APOLLO-SOYUZ TEST PROJECT (ASTP)
OPERATIONS HANDBOOK

STA/T STEP	PROCEDURE	PANEL	REMARKS
CP	11 CMC Self-Check, 8.1.8		
	12 DSKY Condition Lt Test, 8.3.1		
	13 C&WS Oper Check, 5.5.1		
	14 P52 IMU Align, 13.1.3		
	15 Verify COAS locked in stowage mount		
	14.1.2 <u>RSI Test and Alignment</u>		
AC	ELEC PWR - GDC/ECA	7	Permits testing EMS roll stability indicator (RSI) and positioning to desired orientation for entry.
	ATT SET - GDC	1	
	1 EMS ROLL - on (up)		
	GDC ALIGN pb - push, hold		
	ATT SET YAW tw - Adj thru 45° angle, observe RSI tracks ≈45°, then position RSI		Avoid FDAI gimbal lock region.
	GDC ALIGN pb - rel		
	EMS ROLL - OFF		
	2 ATT SET YAW tw - reset		This step required only if GDC was aligned and realignment required.
	GDC ALIGN pb - push (32 sec max)		
	14.1.3 <u>EMS Deorbit and Entry Test</u>		Light illumination other than those listed indicates malfunction. ΔV/EMS SET switch slews G-V scroll and sets RNG indicator. [Lift vector up light (G >0.2) and down light (G <0.2) for entry from lunar mission only.]

14.1.3

EMS DEORBIT AND ENTRY TEST

NORMAL/BACKUP

APOLLO-SOYUZ TEST PROJECT (ASTP)
OPERATIONS HANDBOOK

STA/T STEP	PROCEDURE	PANEL	REMARKS
AC	<p>1 Init EMS prep EMS FUNC - OFF (verify) cb EMS (2) - close EMS MODE - STBY</p>	<p>1 8 1</p>	<p>Test 1 checks lower trip-point of .05 G comparator.</p>
	<p>2 EMS FUNC - EMS TEST 1 (CCW) Wait 5 sec Adj alphanumeric brightness (option)</p>		<p>Ten seconds should be allowed to verify no malfunctions. No light on before or after 10 seconds.</p>
	<p>3 EMS MODE - NORM Wait 10 sec minimum All ind lts - out RNG ind - 0.0</p>		<p>EMS scroll can be slewed only one inch in reverse.</p>
	<p>4 EMS FUNC - EMS TEST 2 (CCW) .05 G lt - on Wait 10 sec All other lts out</p>		<p>Test 2 checks .05 G comparator upper trip-point. No other light on before or after 10 seconds.</p>
	<p>5 EMS FUNC - EMS TEST 3 (CCW) .05 G lt - on</p>		<p>Test 3 checks corridor verification circuitry associated with lift vector down light.</p>
	<p>Lift vector dn lt - on (10 sec after .05 G lt) Set RNG ind to 58.0 MM +0.0</p>		<p>G < 0.2. RNG indicator displays minus sign for negative numbers or no sign for positive numbers in most significant digit.</p>

EMS DEORBIT AND ENTRY TEST

APOLLO-SOYUZ TEST PROJECT (ASTP)
OPERATIONS HANDBOOK

STA/T STEP	PROCEDURE	PANEL	REMARKS
AC	<p>6 EMS FUNC - EMS TEST 4 (CCW) .05 G lt - on (all others out) G-V trace (during 10 sec period) within test pattern After 10 sec, G-V trace stops at lower right corner of test pattern at ≈ 9 G RNG ind (during 10 sec period) counts toward zero. After 10 sec, stops at $\approx 0.0 \pm 0.2$ NM</p>	1	<p>Test 4 checks range-to-go integrator circuits, range-to-go indicator, G-V servo circuits, G-V plotter.</p>
7	<p>EMS FUNC - EMS TEST 5 (CCW) .05 G lt - on Lift vector up lt - on (10 sec after .05 G lt) RNG ind - 0.0 Scribe traces vert line ≈ 9 G to 0.28 ± 0.1 G & stops (trace within test pattern) Align G-V scroll to entry pattern (hairline on 37K fps line)</p>		<p>Test 5 checks corridor verification circuitry associated with lift vector up light and enables scroll slewing to start of entry pattern. After scroll set to $< 37K$ fps, reselecting EMS TEST 5 switch position not permitted; range integrator and scroll synchronization would be lost.</p>
8	<p>EMS FUNC - RNG SET (CCW) G-V traces vert line ≈ 0.28 G to 0.0 ± 0.1 G & stops</p>		
9	<p>EMS FUNC - Vo SET (CCW)</p> <p style="text-align: center;"><u>CAUTION</u></p> <p>Never slew scroll in increase direction more than 1500 fps. Ensures range integrator remains slaved to scroll velocity.</p>		<p>Scroll can be slewed only one inch in reverse. In Vo SET position, both initial velocity in range integrator and scroll velocity change simultaneously.</p>

14.1.3

EMS DEORBIT AND ENTRY TEST

NORMAL BACKUP

APOLLO-SOYUZ TEST PROJECT (ASTP)
OPERATIONS HANDBOOK

STA/T STEP	PROCEDURE	PANEL	REMARKS
AC	Slew scroll until display index (arrow) aligned to predicted entry velocity	1	
10	AV Test and Null Bias Check, 7.6.1		
14.1.1.4	<u>Systems Preparation</u>		
	If suited		
	Press Suit Circuit & PGA Check at 5.0 psia, 5.4.9	351	
ALL	Life vests - donned		
CP	EMEP CAB PRESS sel - OFF		
-1:00:00			
CP 1	CM RCS temp check	101	Checks CM RCS 12, 14, 16, 21, 23, and 25 jet injector valve temperatures, respectively.
	SYS TEST (2) - 4B, 5B, 6B, 7B, 8B, 9B		
	If lowest reading < 1.5 vdc (40°F)	8	
	cb CM RCS HTRS (both) - close		
	cb RCS LOGIC (2) - close	1	
AC	CM RCS LOGIC - on (up)		
CP	CM RCS HTRS - on (up) for 20 minutes	101	Jet injector valve direct coils utilized for preheating jets.
2	URINE DUMP - OFF		
3	WASTE H2O DUMP - OFF		
4	Align RSI & GDC, 14.1.1.2		
5	Set FDAI 2 on ORB RATE & restow, 8.4.8		
6	CM RCS heating completion (if accomplished)		
-40:00	CM RCS HTRS - OFF		

SYSTEMS PREPARATION

APOLLO-SOYUZ TEST PROJECT (ASTP)
OPERATIONS HANDBOOK

STA/STEP	PROCEDURE	PANEL	REMARKS
DP	7 Configure entry bats (req) cb MVA BAT C - close cb MNB BAT C - close	275	
AC	8 Panel 8 - all cb closed (req) except cb PL VENT FLT/PL - open cb FLOAT BAG (all) - open cb EDS (all) - open cb CM RCS HTR (both) - open cb DOCK PROBE (2) - open cb SECS ARM (2) - open cb ELS/CM-SM SEP (2) - open	8	
CP	9 Config RCS SM RCS QUAD PRPLNT (4) - OPEN SM RCS QUAD PRIM PRPLNT tb (4) - gray SM RCS QUAD SEC PRPLNT tb (4) - gray SM RCS PSM He - CLOSE PSM He tb - bp PSM MANF ISOL vlv - CLOSE PSM MANF ISCL tb - bp (verify)	2	Quad helium main isolation valves and helium isolation valves at secondary fuel tanks verified open in 14.1.1.1 (step 5). OPEN position is momentary. Gray indicates quad fuel and oxidizer isolation valves open. Gray indicates quad fuel and oxidizer isolation valves open. CLOSE position is momentary. Barber pole indicates helium isolation valves in PSM closed. Barber pole indicates both fuel and both oxidizer isolation valves in PSM closed.

14.1.3

SYSTEMS PREPARATION

NORMAL/BACKUP

APOLLO-SOYUZ TEST PROJECT (ASTP)
OPERATIONS HANDBOOK

STA/T STEP	PROCEDURE	PANEL	REMARKS
CP	RCS IND sel - A (B,C,D) SM RCS IND SW - PRPLNT QTY SM RCS PSM PRPLNT (4) - CLOSE SM RCS PSM PRPLNT tb (4) - bo	2	CLOSE position is momentary. Barber pole indicates at least one PSM manifold to quad propellant (fuel or oxidizer) isolation valve closed for separation. Any position of PSM helium and manifold isolation switches acceptable.
AC	10 CM RCS activation (red) cb SECS ARM (2) - close After STDN AOS SECS LOGIC (both) - on (up) Report logic arm After GO from STDN SECS PYRO ARM (2) - on (up) CM RCS PRPLNT (both) - on (up) (verify) CM RCS PRPLNT tb (both) - gray CM RCS PRESS - on (up)	8	Lever lock.
CP	RCS IND sel - C11, then 2 CM RCS He PRESS ind - 3600-3800 psia (after 15 min) CM RCS MANF PRESS ind - 287-302 psia	2	Lever lock. On position is momentary. Indicates fuel and oxidizer isolation valves open. Guarded. On position is momentary. Immediately after pressurization, He pressure may drop below 3600 psia.
AC	11 SECS PYRO ARM (2) -- SAFE If SCS - select POO	8 2	Lever lock.
	12 Strut unlock lanyard (2) - unstow & attach handle ends to MDC (req)	Side hatch	
	13 Go to THRUSTING, sec 12		

SYSTEMS PREPARATION

APOLLO-SOYUZ TEST PROJECT (ASTP)
OPERATIONS HANDBOOK

STA/T STEP	PROCEDURE	PANEL	REMARKS
14.2	CM/SM SEPARATION		
1P	1 If SM RCS Deorbit Configure & preload bats		Prepares for battery preloading prior to CM/SM separation and verifies batteries transferred to main buses. (Previously configured in SPS or Hybrid Deorbit Thrusting of 12.2.1, 12.2.3, 12.3.1 or 12.3.3.)
	<u>CAUTION</u>		
	If either bat bus A(B) current fails to incr after cycling respective M BUS TIE switch, configure bats to main buses using cb BAT BUS A(B) BAT C	275	Assumes reconfiguration BAT A(B) and BAT C to MIA(B). cb MIA(B) BAT C closed in Deorbit Entry Vehicle Preparation, 14.1.
12:00	M BUS TIE BAT A/C - on (up) Verify bat bus A current incr &/or bat volt decr M BUS TIE BAT B/C - on (up) Verify bat bus B current incr &/or bat volt decr	5	Verification of current increase for appropriate battery bus via DC AMPS indicator (panel 3) confirms successful operation of main bus tie motor switches. M BUS TIE BAT A/C and B/C switches at or provide two batteries on line if cb MIA & B BAT C (2) - open, or three batteries on line for entry if circuit breakers closed (panel 275).
AC	2 Configure PCS AUTO PCS B/D ROLL B1 & B2 - MNA AUTO PCS B/D ROLL D1 & D2 - MNB AUTO PCS PITCH A3 & C4 - MNB AUTO PCS PITCH C3 & A4 - MNA AUTO PCS YAW B3 & D4 - MNA AUTO PCS YAW D3 & B4 - MNB	8	Assumes desired Attitude Control mode, 7.1, previously selected.
CP	SM RCS QUAD PPPLNT (4) - OPEN (verify)	2	OPEN position is momentary. Opens 16 quad isolation valves.

14.2

CS/SM SEPARATION

NORMAL/BACKUP

APOLLO-SOYUZ TEST PROJECT (ASTP)
OPERATIONS HANDBOOK

STA/T STEP	PROCEDURE	PANEL	REMARKS
CP	SM RCS QUAD PRPLNT tb (8) - gray (verify) SM RCS QUAD SEC FUEL PRESS (4) - OPEN (verify) RCS IND sel - any quad SM RCS IND sw - TK PRESS/QTY (verify) SM RCS PSM PRPLNT (4) - CLOSE (verify) SM RCS PSM PRPLNT tb (4) - bp (verify)	2	Gray indicates quad fuel and oxidizer isolation valves open. OPEN position is momentary. No talkbacks. Opens helium isolation valves between quad helium regulators and secondary fuel tanks. If in PRPLNT QTY position, indicator reads PSM or QUAD propellant quantity depending on position of RCS IND sel switch. Barber pole indicates at least one PSM manifold to quad propellant (fuel or oxidizer) isolation valve closed for separation. Any position of PSM helium and manifold isolation switches acceptable.
AC	3 Mvvr to sep att If CMC cont SC CONT - SCS or CMC MODE - FREE	1	Nominally deorbit burn attitude plus a 45° yaw out of plane. During separation, SCM RCS DAP acting upon CM would produce undesirable rates.
CP	4 RCS TRNFR - CM Test Jets (if min imp, > 1 cycle) RCS TRNFR - SM	2	Minimum impulse may not produce audible jet firing. More than 1 cycle may be required to clear propellant lines of residual pressure and allow propellant to jets
AC	5 DED/RATE - MAX/HI ATT DBD - MAX RATE - HI	1	Conserves propellant between separation and .05

CM/SM SEPARATION

APOLLO-SOYUZ TEST PROJECT (ASTP)
OPERATIONS HANDBOOK

STA./T STEP	PROCEDURE	PANEL	REMARKS
DP 6	Configure telecom VHF AM (2) - off (ctr) OMNI ANT - C S BD ANT OMNI A - C S BD ANT OMNI - OMNI If RCS deorbit TAPE RC DR FWD - FWD	3	
AC 7	Configure ECS PRIM GLY TO RAD - BYP (pull) REPRESS PKG vlv - FILL SRG TK 02 vlv - ON (verify) 02 PRESS IND sw - SURGE TK CRYO 02 PRESS 1 ind - 865-935 psia	325 326	Assures CM 02 supply full before CM/SM separation
AC	REPRESS PKG vlv - ON SM 02 SUP vlv - OFF	326	Removes power from glycol mixer to conserve battery power.
DP 5	cb PRIM RAD CONT/MNA & B (2) - open cb H2O/JRINE DUMP HTR (2) - open	5	
CP 2	POT H2O HTR - OFF GLY EVAP TEMP IN - MAN	2	
AC 8	cb ELS/CM-SM SEP (2) - close Arm SECS SECS LOGIC (both) - on (up) (verify) SECS PYPO ARM (2) - on (up)	8	SECS LOGIC and pyro arm lever lock switches required for sequencing of CM/SM separation and landing events.
CP 9	PPPLNT DUMP - RCS CMD (verify)	2	Was set to RCS CMD 61 seconds after lift-off. CM PCS activated in 14.1.4.
AC 1	EMS MODE - STBY (verify)	1	Should remain at STBY until just prior to entry interface to preclude false .05 G sensing.

14.2

CM/SM SEPARATION

NORMAL/BACKUP

APOLLO-SOYUZ TEST PROJECT (ASTP)
OPERATIONS HANDBOOK

STA/T STEP	PROCEDURE	PANEL	REMARKS
CP 10 00:00	Sep from SM CM/SM SEP (both) - on (up) SM C/W lts - on C/W CSM - CM	2	Guarded. On position is momentary. Low limit SM system lights on at separation.
AC CP	MASTER ALARM pb/lit - on, push SM C/W lts - out Perform DM Jett, 4.4 RCS TRNFR - CM	1 2	CM position is momentary. Backup to automatic RCS transfer.
AC	CM RCS LOGIC - OFF	1	Entry DAP not turned on.
11	Sel Att Cont mode, 7.1 Mnvr to entry att (or to SM RCS deorbit att if hybrid deorbit) R <u>o</u> , P <u>o</u> , Y <u>o</u>		
12	Set up for CM/RCS sys 1 (omit for hybrid deorbit) AUTO RCS A/C ROLL (4) - OFF AUTO RCS CM 1 (6) - MNA or MNB AUTO RCS CM 2 (6) - OFF	8	G&N entry DAP will function with either one or both CM/RCS systems enabled. Electrically isolates CM RCS system 2 for entry. If a problem develops in system 1, disable affected channel and use direct RCS control.
13	Go to P61 Entry Prep, 14.3.1 or Go to SCS Entry, 14.4 or If G&N Hybrid Deorbit, go to 12.2.3 (step 16) or If SCS Hybrid Deorbit, go to 12.3.3 (step 14)		

CM/SM SEPARATION

APOLLO-SOYUZ TEST PROJECT (ASTP)
OPERATIONS HANDBOOK

STA/T STEP	PROCEDURE	PANEL	REMARKS
14.3	G&N ENTRY	P61	displays predicted entry interface parameters and obtains EMS initialization parameters for comparison with STDN values.
14.3.1	<u>P61 Entry Preparation</u>		
	Required		
	CMC - on, 8.1.3		
	ISS - on & orient known, 8.1.3 & sec 13		
	SCS - on, 8.4.2		
	CMC ATT IMU (verify)		
	.05 G sw - OFF (verify)		
CP	1 DSKY - P61 (sel at end of deorbit burn)	2	
	or Key V37E 61E		R02.
	Poss PROG alarm (8.1.16)		
	(R41 - State Vector Integration)		Indicates state vector integration in process. Indicates integration complete, and average G on.
	COMP ACTY It - on (R41)		
	COMP ACTY It - flashes every 2 sec (ave G on)		
	Poss PROG alarm		Zero roll on FDAI is lift-down. -Ysm within 30° of V x R. Alarm 01427 always displayed following P40 or P41 deorbit if platform aligned to preferred orientation computed in P40 or P41.
	V05 N09 (10 sec)		
	01427 (IMU reversed)		Neither +Ysm or -Ysm within 30° of $\underline{V} \times \underline{R}$.
	or 01426 (IMU unsatisfactory for entry)		

14.3.1 P61 ENTRY PREPARATION

NORMAL BACKUP

APOLLO-SOYUZ TEST PROJECT (ASTP)
OPERATIONS HANDBOOK

STA/T STEP	PROCEDURE	PANEL	REMARKS
CP 2	FL V06 N61 Impact Lat (+N) XXX.XX DEG Impact Long (+E) XXX.XX DEG Hds Up/Dn (+up) +/-00001 Accept PRO Reject V25E, load desired values	2	Latitude and longitude of desired impact point. Heads up/down defines entry roll attitude. Normally, these values loaded prior to deorbit.
3	FL V06 N60 (entry data) G max XXX.XX G V pred XXXXX. FPS Gamma EI XXX.XX DEG Rcd values PRO FL V16 N63		Predicted maximum G level for an entry at nominal bank angle (L/D = 0.18). Predicted inertial velocity at entry interface (65.8 NM, 400,000 ft) above Fischer ellipsoid. Flight path angle (between inertial velocity vector and local horizontal) at 65.8 NM (400,000 feet) above Fischer ellipsoid. Minus indicates flight path below horizontal plane.
4	RTOGO (.05 G to splash) XXXX.X NM V10 (at .05 G) XXXXX. FPS		Display relative to erasable preloaded altitude value above Fischer ellipsoid. Range to go from preloaded erasable altitude value to splash. Predicted inertial velocity at preloaded altitude value.

P61 ENTRY PREPARATION

APOLLO-SOYUZ TEST PROJECT (ASTP)
OPERATIONS HANDBOOK

STA/T STEP	PROCEDURE	PANEL	REMARKS
CP	TFE (time from .05 G) XXBXX MIN-SEC	2	Predicted time from now to preloaded altitude value (updated every 2 seconds). Predicts about 3 minutes longer than actual, following hybrid deorbit when called half hour before .05 G. Error varies, depending on how early P61 called after deorbit. 59B59 maximum reading (-above, +below).
AC	Rcd & compare with STDN EMS - STBY/RNG SET (CW) EMS MODE - STBY EMS FUNC - RNG SET (CW) Set RNG ind - RTO30 from .05 G (STDN value) If req EMS FUNC - Vo SET (CCW)	1	Do not go through EMS TEST positions. Range to go from preloaded value to splashdown.
CP	Align scroll Vo to exact entry velocity (if req) EMS FUNC - ENTRY Position EMS lt filter down (lts not covered) Accept PRO (Exit P61) P61 calls P62 Go to G&N Entry, 14.3.2 Reject V32E, recycle to step 3	2	Predicted entry velocity may have been preset in EMS Entry Test, 14.1.3. Scroll can be slewed only one inch in reverse. In Vo SET position, both initial velocity in range integrator and scroll velocity change simultaneously. Removing filter improves visibility of EMS lights during entry. Obtains new state vector and updated N60.

P61 ENTRY PREPARATION

14.3.1

NORMAL BACKUP

APOLLO-SOYUZ TEST PROJECT (ASTP)
OPERATIONS HANDBOOK

STA/T STEP	PROCEDURE	PANEL	REMARKS
14.3.2	<p>P62, P63, P64, P67 Entry</p> <p>Required CMC - on, 8.1.3 ISS - on & orient known, 8.1.3 & sec 13 SCS - on, 8.4.2 CMC ATT - IMU (verify) .05 G sw - OFF (verify)</p>		
CP 1	<p>DSKY - P62 Auto sel by P61 (bypasses state vctr extrapolation reqt)</p>	2	
or	<p>If FL V37 Key 62E</p>		
or	<p>Key V37E 62E (ave G reinitiated)</p> <p>Poss PROG alarm (8.1.16)</p> <p>(R41 - State Vector Integration)</p> <p>COMP ACTY lt - on (R41)</p> <p>COMP ACTY lt - flash every 2 sec (ave G on)</p> <p>Poss PROG alarm V05 N09 (10 sec) 01427 (IMU reversed)</p>		<p>R02.</p> <p>R41 bypassed if P62 called by P61.</p> <p>Indicates integration in process.</p> <p>Indicates integration complete, and average G on.</p> <p>Zero roll on FDAI is lift-down. -Ysm within 30° of V x R. Alarm 01427 always displayed following P40 or P41 deorbit if platform aligned to preferred orientation computed in P40 or P41.</p>

P62, P63, P65, P67 ENTRY

APOLLO-SOYUZ TEST PROJECT (ASTP)
OPERATIONS HANDBOOK

STA/T STEP	PROCEDURE	PANEL	REMARKS
CE	or 01426 (IMU unsatisfactory for entry) 2 FL V50 N25 00041 (request CM/SM sep)	2	Neither +Ysm or -Ysm within 30° of $V \times E$. If CM and SM not separated prior to this step, separation should be accomplished now per 15.2. V37s except P00, inhibited after response to this display. Any program not requiring DAP control may be selected from P00. P62 should be reselected before entry into atmosphere since average G terminates by going to P00.
3	PRO		Starts entry DAP. Roll attitude error scaling changed in G&N for compatibility with 50/15/50/10 FDAI scale position. After PRO and until 50/15/50/10 selected, full scale roll error 20°, not 5°.
4	FL V06 N61 Impact lat (+N) XXX.XX DEG Impact long (+E) XXX.XX DEG Has Up/Dn (+up) +/-00001		Latitude and longitude of desired impact point. Defines entry roll attitude.
5	Accept PRO If $\alpha < 45^\circ$ - DSKY P63, go to 6 Reject V25E load new data V06 N22 (mon) R, P, Y XXX.XX DEG If $\alpha > 45^\circ$ 21 sec after $\alpha < 45^\circ$, DSKY P63		If α within 45° of (-) velocity vector, P63 automatically called. Final gimbal angles at EI. Display bypassed and P63 called if α within 45°.

14.3.2

P62, P63, P64, P67 ENTRY

NORMAL BACKUP

APOLLO-SOYUZ TEST PROJECT (ASTP)
OPERATIONS HANDBOOK

STA/T STEP	PROCEDURE	PANEL	REMARKS
CP 9	V06 N64 (mon) Drag accel VI	2	N68 and N74 available if desired. Inertial velocity (nominal). Range to go to desired splashpoint located at calculated impact time (decreasing). Display bypassed on first 2-second cycle.
DP	Range to splash (+ overshoot)	3	
AC	PCM BIT RATE - HI TAPE RCDR RCL - RCD TAPE RCDR FWD - FWD EMAG MODE (3) - RATE 2	1	Cages attitude EMAGs. Prevents SCS-driven FDAI roll stability indicator from jumping when GA 1 EMAGs automatically cage at .05 G. Configuration required for auto G&N entry and normally selected at last status check prior to .05 G. Entry DAF does not look at CMC MODE switch.
CF	MAN ATT (3) - RATE CMD SC CONT - CMC CMC MODE - AUTO, HOLD, or FREE DSKY - P64 (at .05 G)	2	CMC changes Entry DAP from attitude hold in alpha and beta to rate damping in pitch and yaw (roll unchanged). EMS started manually to ensure start of range indicator at fixed position (range from target) as defined by RTCC. .05 G lt will not necessarily occur simultaneously with P64 on DSKY.
	EMS MODE - BU .05 G lt - on		

14.3.2

P62, P63, P64, P67

NORMAL BACKUP

APOLLO-SOYUZ TEST PROJECT (ASTP)
OPERATIONS HANDBOOK

STA/T STEP	PROCEDURE	PANEL	REMARKS
AC	.05 G sw - on (up) EMS ROLL - on (up) Scroll slews to left RNG ind decr	1	.05 G and EMS ROLL switches should be placed on simultaneously to minimize EMS error.
CP 10	V06 N74 (mon) Beta VI Drag accel	2	N64 and N68 available if desired. Commanded bank angle. Inertial velocity (decreasing). Drag acceleration (increasing).
AC	Compare RSI & ball for lift vectr G-V plot within limits	1	Violation of an EMS G onset ray should be followed by an orientation to lift vector up. Violation of an EMS G offset ray should be followed by an orientation to lift vector down. If at point of tangency, G&N not commanding lift-up or lift-down, manually orient CM and terminate G&N steering.
0.2G		2	P67 continues entry guidance from =0.2 G until termination of steering when the CM velocity with respect to earth = 1000 ft/sec (=10.7 NM altitude). N64, N68, and N74 available if desired.
CP 11	DSKY - P57 EMS - 0.2 G (if 10 sec since .05 G)	1	
AC			
CP 12	V06 N66 (mon) Beta CRSRNG ERR DWRNG ERR	2	Commanded bank angle (-command will correct for + cross range error). CMC solution for cross range error (+ target south of direction of motion). CMC solution for down range error (decreasing); + is overshoot. Will be 9999.9 after overshoot of target.

P62, P63, P64, P67 ENTRY

APOLLO-SOYUZ TEST PROJECT (ASTP)
OPERATIONS HANDBOOK

STA/T STEP	PROCEDURE	PANEL	REMARKS
CP	Key VERB (freeze disp) Compare DWRNG ERR to pad data (DWRNG ERR within 100 NM of pad data) XXXXXXXXXXXXXXXXXXXXXXXXXXXXXXXXXXXXX X If DWRNG ERR not within 100 NM Maintain BBA entry XXXXXXXXXXXXXXXXXXXXXXXXXXXXXXXXXXXXX X	2	
AC	KEY REL (reinstates V06 N66 mon)		
AC	Fly roll cmd Mon lift vctr on RSI & ball	1	
CP	13 FL V16 N67 (mon) Range to splash XXXX.X NM (+ ovsht) Lat present position XX.YX DEG (+ N) Long present position XXX.XX DEG (+ E) (V REL = 1000 fps at ≈65K')	2	Range to 0 to desired splashpoint (+ is overshoot). Latitude of present position (+ is north). Longitude of present position (+ is east).
AC	If RL = -, lift-up; +, lift-down Mon altimeter Rcd lat, long, & voice to RECY at 10K' Rcd EMS RTOGO EMS - STBY/OFF EMS MODE - STBY EMS FUNC - OFF	1	
	14 Go to Earth Ldg Phase (<50K'), sec 15		

14.3.2

P62, P63, P64, P67 ENTRY

NORMAL BACKUP

APOLLO-SOYUZ TEST PROJECT (ASTP)
OPERATIONS HANDBOOK

STA/T STEP	PROCEDURE	PANEL	REMARKS
14.4	SCS ENTRY		
	CMC - on (desired), 8.1.3 ISS - on & orient known (desired), 8.1.3 & sec 13 SCS - on (req), 8.4.2 CMC ATT - IMU (verify) .05 G sw - OFF (verify) RSI aligned, 14.1.2		Assumes CM and SM separated. During entry, do not "fly to" a pegged rate needle. For this contingency, control to operational attitude ball or out-the-window visual cues.
AC	1	Verify/mnvr to entry att	SCS acceleration command recommended until .05 G for failure takeover considerations.
	2	EMS Entry Test (req), 14.1.3 EMS - STBY/RNG SET (CW) EMS MODE - STBY EMS FUNC - RNG SET (CW)	Do not go through EMS TEST positions. The following steps to be done as soon as possible after deorbit AV.
	3	Set RNG ind - RTGC from .05 G (STDN value) EMS FUNC - Vo SET Realign scroll Vo to exact entry velocity (if req)	Predicted entry velocity may have been preset in EMS Entry Test, 14.1.3. Scroll can be slowed only one inch in reverse. In Vo SET position, both initial velocity in range integrator and scroll velocity change simultaneously.

SCS ENTRY

APOLLO-SOYUZ TEST PROJECT (ASTP)
OPERATIONS HANDBOOK

STA/T STEP	PROCEDURE	PANEL	REMARKS
AC	4 EMS FUNC - ENTRY	1	<p>This alignment may be performed prior to launch or prior to deorbit.</p> <p>EMS roll stability indicator alignment provides indication of backup bank angle (BBA).</p> <p>Left in STBY until after separation and stabilization; if no postburn update, and for RCS deorbit, start EMS by positioning MODF switch from STBY to FU at STDN supplied value of PWT .05 G. Also refer to 6.1.1, note 10.</p> <p>Cages attitude RWAGs, preventing SCS-driven FDAI RSI jumping at .05 G when GA 1 attitude RWAGs automatically caged to furnish rate information for SCS-driven FDAI RSI. This configuration can be delayed, as close to .05 G as convenient, for propellant conservation.</p>
	5 Align RSI to desired angle (if necessary) ATT SFT - GDC EMS ROLL - on (up) GDC ALIGN pb - push, hold ATT SET YAW tw - adj $\pm 45^\circ$, position RSI		
	GDC ALIGN pb - rel EMS ROLL - OFF ATT SET YAW tw - reset GDC ALIGN pb - push (32 sec max)		
	6 After CM SM sep & CM stab at entry att EMS MODE - NORM		
	DBD/RATE - MAX/HI ATT DED - MAX RATE - HI FDAI SCALE - 50/15/50/10 RWAG MODE (3) - RATE 2 MAN ATT ROLL - ACCEL CMD MAN ATT PITCH & YAW - RATE CMD		
DF	PCM BIT RATE - HI TAPE RCDR RCD - RCD TAPE RCDR FWD - FWD	3	

SCS ENTRY

14.4

NORMAL/BACKUP

APOLLO-SOYUZ TEST PROJECT (ASTP)
OPERATIONS HANDBOOK

STA/T STEP	PROCEDURE	PANEL	REMARKS
AC,CP	Monitor FDAIs & RSI XXXXXXXXXXXXXXXXXXXXXXXXXXXXX	1,2	
AC	If abnormal veh dynamics Damp rates with dir RCS RHC PWR DIR (both) - OFF If abnormal veh dynamics continue RHC PWR DIR (both) - MNA/MNB Damp rates with dir RCS AUTO RCS (affected axis) - OFF Continue with dir RCS (affected axis) XXXXXXXXXXXXXXXXXXXXXXXXXXXXX	1 8	This procedure sequence minimizes failure isolation time. (Another functionally acceptable method disables AUTO RCS switches first, then RHC direct power.)
7	EVNT TMR ind - mon for .05 G time .05 G lt - on XXXXXXXXXXXXXXXXXXXXXXXXXXXXX If no .05 G lt by REF .05 G +3 sec EMS MODE - BU XXXXXXXXXXXXXXXXXXXXXXXXXXXXX .05 G sw - on (up) EMS ROLL - on (up)	1	Backup cue may be obtained from STDN or CMC. Lift vector lights do not function in EMS BU mode. If RNG indicator not decreasing, EMS ranging capability lost. At .05 G +10 sec, one lift vector light will come on; disregard light. .05 G and EMS ROLL switches should be placed to on simultaneously to minimize roll attitude error.

SCS ENTRY

APOLLO-SOYUZ TEST PROJECT (ASTP)
OPERATIONS HANDBOOK

STA/T STEP	PROCEDURE	PANEL	REMARKS
AC	<p>Scroll slews to left, RNG ind decreases</p> <p>Mnvr to BBA & maintain until range potential guidelines can be interpreted, then null range err using range potential guidelines & EMS RNG ind. While nulling range err, avoid tangency to G on-set lines. Reverse bank angle at RETRB to null lateral range err.</p> <p>8 Go to Earth Landing Phase (<50K'), sec 15</p>	1	<p>If scroll slews in one axis (V or G), that axis is usable.</p> <p>BBA is backup bank angle.</p> <p>Disregard corridor lamps (as corridor verification cues) for entry from earth orbit (entry velocity <35K fps).</p> <p>RETRB is retrofire elapsed time to reverse bank.</p>

14.4

SCS ENTRY



APOLLO-SOYUZ TEST PROJECT (ASTP)
OPERATIONS HANDBOOK

STA/T STEP	PROCEDURE	PANEL	REMARKS
15.0	EARTH LANDING PHASE (<50K')		
AC 50K'	CAB PRESS RELF vlv (2) - BOOST/ENTER (safety latch on) Report CM stable XXXXXXXXXXXXXXXXXXXXXXXXXXXXXXXXXXXXX CM unstable	325	
CP 40K'	RCS CMD - OFF	2	OFF position is momentary.
AC	APEX COVER JETT pb - push DROG DPLY pb - push (2 sec after apex cover jett) XXXXXXXXXXXXXXXXXXXXXXXXXXXXXXXXXXXXX	1	Guarded. Guarded.
30K'	ELS LOGIC - on (up)		Guarded.
CP	ELS AUTO - AUTO	2	Required only if secondary loop in operation.
24K'	SEC COOL EVAP - off (ctr) GLY EVAP H2O FLOW - off (ctr) SCS RCS disable (auto) XXXXXXXXXXXXXXXXXXXXX RCS CMD - OFF XXXXXXXXXXXXXXXXXXXXX Apex cover jett (auto)		OFF position is momentary. Apex cover will be jettisoned at 24K feet plus 0.4 second.

EARTH LANDING PHASE (<50K')

15.0

NORMAL BACKUP

APOLLO-SOYUZ TEST PROJECT (ASTP)
OPERATIONS HANDBOOK

STA/T STEP	PROCEDURE	PANEL	REMARKS
CP 10K'	CAB PRESS ind - 10 psia Main chutes & VHF recovery ant deploy (auto)	2	Indication of main chute deploy altitude. Auto deployment occurs between 10,950 and 9,100 feet. Parachutes disreef =15 seconds after pilot mortars fire.
AC	MN DPLY pb - push	1	Guarded.
DE	Set up entry communications VHF ANT - RECY VHF AM A - SIMPLEX VHF BCN - ON	3	If VHF AM B - SIMPLEX or VHF AM A - DUPLEX required, turn off beacon during period of communication.
AC	Transmit voice (VHF AM) reporting Position Main chutes disreefed Splash error Crew status		Continue voice transmission until touchdown.
CF	Crew couch struts (4) - unlock		
AC	CAB PRESS RELF vlv (2) - DUMP (safety latch off)	325	
	If night landing cb FLOAT BAG (all) - close FL BCN LT - LO	8 15	The postlanding beacon light has longer operating life in IO.

EARTH LANDING PHASE (<50K')

15.0

NORMAL BACKUP

APOLLO-SOYUZ TEST PROJECT (ASTP)
OPERATIONS HANDBOOK

STA/T STEP	PROCEDURE	PANEL	REMARKS
DP	cb FLT/PL BUS BAT A, B & C (3) - close	5	Connects battery bus A, B, and battery C to flight and postlanding bus.
AC	cb FLT/PL BUS MHA & B (2) - open	8	
CP	cb SPS PITCH (both) - open		
	cb SPS YAW (both) - open		
	CM RCS PRPLWT (both) - OFF	2	OFF position is momentary.
	CM RCS PRPLWT tb (both) - bp		Barber pole indicates at least one valve (fuel or oxidizer) closed in the particular system 1 or 2.
AC	FLOOD FIXED - POST LDG	8	Provides power from flight and postlanding bus to one floodlight in LH couch area and one floodlight in center couch area. Minimize floodlight use during postlanding. Maximum utilization should be 9.6 hours per 48-hour period.
	FLOOD DIM - 1 or 2		Position 1 provides power to two secondary floodlights and position 2 provides power to two primary floodlights when FLOOD FIXED switch in POST LDG position after dc main buses are deactivated.
	CAB PRESS RELF vlv (2) - CLOSE (safety latch off)	325	Valves must be closed prior to touchdown to prevent water from entering CM.
CP	XXXXXXXXXXXXXXXXXXXXXXXXXXXXXXXXXXXXX X If CAB PRESS DUMP vlv used to equalize ΔP, CAB PRESS DUMP vlv - close (CW) XXXXXXXXXXXXXXXXXXXXXXXXXXXXXXXXXXXXX X	Side hatch	

EARTH LANDING PHASE (<50K')

APOLLO-SOYUZ TEST PROJECT (ASTP)
OPERATIONS HANDBOOK

STA/T STEP	PROCEDURE	PANEL	REMARKS
AC	ELS AUTO - AUTO (verify) ELS LOGIC - on (up) (verify) DIRECT O2 vlv - OPEN (CCW) (if suited) MN BUS TIE (2) - OFF	1	Guarded.
DP	<p style="text-align: center;"><u>CAUTION</u></p> MN BUS TIE switches must be left OFF to ensure that entry batteries A, B, & C are used to power PL bus only, & to prevent battery shorting caused by water entering CM feed-thru connectors. cb BAT RLY BUS (2) - open Postlanding Check, sec 16	7 5	Removes battery power from dc main buses.

EARTH LANDING PHASE (<50K')

15.0

NORMAL BUS

APOLLO-SOYUZ TEST PROJECT (ASTP)
OPERATIONS HANDBOOK

STA/T STEP	PROCEDURE	PANEL	REMARKS
AC	<p>If CM fails to upright in 7 min & CM rolls CW</p> <p>FLOAT BAG 2 R - OFF (Continue uprighting for 8 additional min)</p>	8	Crew reposition procedures may be required if uprighting does not occur in 7 minutes and sea state is minimal.
CP,AC	<p>If uprighting does not occur in 3 min, reposition to area behind AC's couch and CP's couch as near as poss to B3 stowage locker</p>		Lever lock.
AC	<p>or CM rolls CCW</p> <p>FLOAT BAG 1 L - OFF (Continue uprighting for 8 additional min)</p>		Lever lock.
DP,CP	<p>If uprighting does not occur in 3 min, reposition to area behind DP's couch & CP's couch</p>		
AC	<p>or No roll</p> <p>FLOAT BAG 3 CTR - OFF (Continue uprighting for 8 additional min)</p>		Lever lock.

POSTLANDING STABILIZATION

16.1

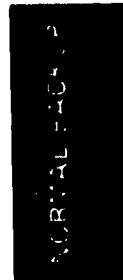

APOLLO-SOYUZ TEST PROJECT (ASTP)
OPERATIONS HANDBOOK

STA/T STEP	PROCEDURE	PANEL	REMARKS
CP,DP	<p>If uprighting does not occur in 3 min, reposition to area on top of or along lower equip bay canisters</p> <p><u>WARNING</u></p> <p>If CM still does not upright, egress should be completed before total time in unventilated CM exceeds 2-1/2 hours. Refer to Stable II Water Egress Procedure, 16.4.3.</p> <p>XXXXXXXXXXXXXXXXXXXXXXXXXXXXX</p>		

POSTLANDING STABILIZATION

APOLLO-SOYUZ TEST PROJECT (ASTP)
OPERATIONS HANDBOOK

STA/T STEP	PROCEDURE	PANEL	REMARKS
16.2	POST STABILIZATION AND VENTILATION		
ALL	Release footstraps		
DP	Release restraint harness	275	
	cb MNA BAT BUS A & BAT C (2) - open		
	cb MNB BAT BUS B & BAT C (2) - open		
	cb FLT/PL BUS BAT C - open	5	Battery C and pyro batteries held in reserve for use after depletion of battery A and B charge.
	cb PYRO BUS A/PYRO BAT A - open	229	
	cb PYRO BUS B/PYRO BAT B - open		
	DC IND sel - BAT BUS A,B	3	
	DC VOLTS ind - >27.5 vdc		
	When BAT BUS A(B) = 27.5 vdc, monitor that bus continuously		
	XXXXXXXXXXXXXXXXXXXXXXXXXXXXXXXXXXXXX		
	If BAT BUS A & B (2) <27.5 vdc		
	cb FLT/PL BUS BAT C - close		
	cb FLT/PL BUS BAT A & B (2) - open	5	
	Go to Comm Low Pyr Procedures, 16.3.3, and monitor BAT C voltage		
	XXXXXXXXXXXXXXXXXXXXXXXXXXXXXXXXXXXXX		
CP	PLV distribution duct (3) - unstow and install		Stowed in aft bulkhead stowage area.
	Remove debris trap from left X-X head strut at MDC		Allows cabin air to flow to PL valve exhaust port on forward bulkhead.

16.2

POST STABILIZATION AND VENTILATION

NORMAL BACKUP

APOLLO-SOYUZ TEST PROJECT (ASTP)
OPERATIONS HANDBOOK

STA/T STEP	PROCEDURE	PANEL	REMARKS
AC	PL BCN LT - LO xxxxxxxxxxxxxxxxxxxxxxxxxxxxxxxx If no flashing light FLOOD FIXED - POST LDG for 1/2 min OFF for 1/2 min xxxxxxxxxxxxxxxxxxxxxxxxxxxxxxxx	15 8	After dark only. Place PL BCN LT - HI only at request of recovery forces. Perform backup duty cycle at request of recovery forces.
ALL	Deploy dye marker & swimmer umbilical DYE MARKER - on (up) INTERCOM (3) - T/R (verify)	15 9,10,6	Guarded. On (up) position is momentary. Required for swimmer umbilical operation.
AC	Deploy line grappling hook (if req) CAB PRESS DUMP vlv - remove Grappling hook & line - deploy through valve opening Cover plate - secure Go to Nominal Egress, 16.5	Side hatch	Grappling hook deployed on request for snagging sea anchors deployed by recovery forces. Adapter E and driver R tools required to remove cabin pressure dump valve and secure cover plate on side hatch (over valve opening).

16.2

POST STABILIZATION AND VENTILATION

NORMAL BACKUP

APOLLO-SOYUZ TEST PROJECT (ASTP)
OPERATIONS HANDBOOK

STA/T STEP	PROCEDURE	PAGE	REMARKS
16.3	POSTLANDING COMMUNICATIONS		
16.3.1	<u>Normal Postlanding Communications</u>	3	
DP	VHF BCN - ON (verify) VHF ANT - RECY (verify) If no contact with recovery forces VHF A1 B - SIMPLEX Monitor for VHF beacon 1000 Hz tone (2 sec on, 3 sec off) VHF A1 B - off (ctr) If VHF beacon not audible Remove survival transceiver from storage and mount antenna Select VOICE on transceiver Monitor VHF beacon for 1000 Hz tone (2 sec on, 3 sec off) If VHF beacon operating Turn off survival transceiver Stow transceiver in RHFEB xxxxxxxxxxxxxxxxxxxxxxxxxxxxxxxxxxxx x If no VHF beacon signal, turn off transceiver, remove antenna, & connect transceiver to S/C antenna per 16.3.2 Select BCN on transceiver Monitor VHF A1 for comm initiated by recovery aircraft xxxxxxxxxxxxxxxxxxxxxxxxxxxxxxxxxxxx x		
16.3.2	<u>Survival Transceiver Communications</u>	3	Conserve spacecraft power for terminal phase of recovery operations.
	VHF BCN - OFF (if no contact after 24 hrs)		

SURVIVAL TRANSCEIVER COMMUNICATIONS

APOLLO-SOYUZ TEST PROJECT (ASTP)
OPERATIONS HANDBOOK

STA/T STEP	PROCEDURE	PANEL	REMARKS
DP	Survival transceiver/VHF BCN antenna cable connection Remove survival transceiver from stowage Unlatch & open VHF antenna access door		A 5/32" hex wrench (tool E), required for opening two hex fasteners on antenna cable access door.
	Disconnect PLL2 connector from beacon		An adjustable wrench (tool F), is used to loosen 5/8" hex on coax connector.
	Attach transceiver cable P1 connector to transceiver (verify)		
	Connect transceiver cable J1 connector to PLL2 connector		
	Select BCN on transceiver		
	<u>16.3.3 Communications Low Power Procedures</u>		
AC	VHF BCN - OFF	8	
DP	FLOOD FIXED - OFF	3	Turns off post-landing floodlights.
	VHF AM A - off (ctr)		
AC	VHF AM RCV - A		
	PL VENT sys - minimize use		
	Survival transceiver - connect to VHF BCN antenna cable (refer to Survival Transceiver Communications, 16.3.2)		
	If BAT C < 27.5 vdc		
	cb BAT BUS A BAT A - open	275	
	cb BAT BUS A PYRO BAT A - close		
	cb FLT/PL BUS BAT A - close		
	cb FLT/PL BUS BAT C - open	5	
	Monitor PYRO BAT A voltage on BAT BUS A		

16.3.3

COMMUNICATIONS LOW POWER PROCEDURES

NORMAL BACKUP

APOLLO-SOYUZ TEST PROJECT (ASTP)
OPERATIONS HANDBOOK

STA/T STEP	PROCEDURE	PANEL	REMARKS
DP	If PYRO BAT A <27.5 vdc cb BAT BUS B BAT B - open cb BAT BUS B PYRO BAT B - close cb FLT/PL BUS BAT B - close cb FLT/PL BUS BAT A - open Monitor PYRO BAT B voltage on BAT BUS B	275 5	Spacecraft power conserved for extended survival communications period. Postlanding vent system use should be minimized; however, total time without ventilation or CM O2 supply should not exceed 2-1/2 hours. Side hatch or dump valve can be opened as required to obtain fresh air if no PL VENT operation.
AC	16.3.4 <u>S/C Power Down (Extended Comm Period)</u> PL VENT - OFF	15	
DP	cb FLT/PL BUS BAT C - open cb BAT CHRG BAT C/EDS 2 - open cb panel 275 - all open Power up as req, 16.3.3	5 275	

S/C POWER DOWN (EXTENDED COMM PERIOD)

APOLLO-SOYUZ TEST PROJECT (ASTP)
OPERATIONS HANDBOOK

STA/T STEP	PROCEDURE	PANEL	REMARKS
DP	Connect lanyard titled "attach to second crewman out" to suit (if unsuited attach to buckle on life vest)		
AC	Connect lanyard titled "attach to third crewman out" to suit (if unsuited attach to buckle on life vest)		
	16.4.2 <u>Stable I Water Egress</u>		
AC	PL VENT - OFF	15	
DP	cb FLT/PL BUS BAT C - open cb BAT CHRG BAT C/EDS 2 - open cb panel 275 - all open	5 275	
CP	Charge hatch counterbalance GN2 ratchet handle - operate GN2 vlv handle - unlock & push outboard Open side hatch Lock pin rel knob - UNLATCH Gear box sel - UNLATCH Actr handle sel - U (unlatch) Actr handle rel - push or squeeze	Side hatch	Push button or squeeze bar to release actuator handle for operation.
	Actr handle - operate (until hatch can be opened) Push hatch open Act handle sel - N (neut) GN2 vlv handle - vent (pull inboard) GN2 vlv handle - press (push outboard)		

STABLE I WATER EGRESS

APOLLO-SOYUZ TEST PROJECT (ASTP)
OPERATIONS HANDBOOK

NORMAL BACKUP

STA/T STEP	PROCEDURE	PANEL	REMARKS
CP	Check pressure gage (mid-white) Repeat vent, press cycle, as req to obtain mid-white range		Counterbalance vented to mid-white range to assist in securing spacecraft hatch after crew egress.
AC	Remove life raft from rucksack kit No. 2 Simultaneously throw life raft overboard and pull inflation lanyard Place hardware rucksack in raft		
DP	Egress, inflate life vest, board raft		
CP	Egress, inflate life vest, board raft		
	16.4.3 <u>Stable II Water Egress</u>		
ALL	PWR (3) - OFF SUIT PWR (3) - OFF	6,9,10	
CP	PRESS EQUAL vlv - OPEN	Fwd hatch	Pull detent knob on end of handle, then pivot up 90°. Rotate crank ≈ 3 turns CCW to fully open valve. This will flood tunnel prior to opening hatch.
	<u>WARNING</u> To prevent injury to crew members, do not unlock hatch until flooding stops and pressure equalizes in CM.		
CP	Actr handle rel - pull and rotate	Fwd hatch	To free actuator handle for operation, release is rotated to mechanical stop.

STABLE II WATER EGRESS

16.4.3

APOLLO-SOYUZ TEST PROJECT (ASTP)
OPERATIONS HANDBOOK

STA/T STEP	PROCEDURE	PANEL	REMARKS
CP	Actr handle - pull to stop Actr handle sel - U (unlatch) (CCW 90°) Actr handle - push to stop Actr handle sel - stow (CW 90°) Actr handle - push to stowed position Remove & stow fwd hatch		Actuator handle should move ≈ 80°. Actuator handle should move 60° to release hatch. Forward hatch weighs ≈ 85 lbs and is stowed in LHEB.
CP,DP	Lower hardware rucksack down tunl. When rucksack clear of tunl, lower life raft package down tunl holding package with yellow lanyard		
CP	Exit feet first; when clear of CM, inflate life vest Exit feet first; when clear of CM, inflate life vest Remove life raft from rucksack No. 2 and inflate raft		
DP	Disconnect life raft mooring line (olive drab) from CM and return end of line (AC's discretion)		
CP,DP	Exit feet first; when clear of CM inflate life vest Reconnect life raft mooring line (olive drab) to SC exterior - sea anchor hardpoint or EVA handles (AC's discretion)		
AC	16.4.4 <u>Side Hatch Operations - Rough Sea</u>		
CP	Close side hatch GN2 vlv handle - pull (inboard)	Side hatch	Vents counterbalance piston chamber. Squeeze handle to unlock.

SIDE HATCH OPERATIONS - ROUGH SEA

APOLLO-SOYUZ TEST PROJECT (ASTP)
OPERATIONS HANDBOOK

STA/T STEP	PROCEDURE	PANEL	REMARKS
CP	GN2 press ind - minimum Open door rel handle - pull Verify latches are in open position Close hatch Actr handle sel - L (latch) Gear box sel - LATCH Open door rel handle - stow Actr handle rel - push or squeeze Actr handle - operate (while holding hatch closed) Lock pin rel knob - LOCK (auto) LOCK PIN ind - not extended Actr handle - stowed Re-open side hatch Lock pin rel knob - UNLOCK Gear box sel - UNLATCH Actr handle sel - U (unlatch) Actr handle rel - push or squeeze GN2 vlv handle - push (outboard) GN2 press ind - green Actr handle - operate (until hatch can be opened)		D-ring. Push button or squeeze bar to release actuator handle for operation. Verify lock pin has automatically engaged. Indicates lock pin engaged. Pin can be sheared if left in LOCK position. Actuator handle should not be operated until immediately prior to egress.

16.4.4

SIDE HATCH OPERATIONS - ROUGH SEA

NORMAL BACKUP

APOLLO-SOYUZ TEST PROJECT (ASTP)
OPERATIONS HANDBOOK

STA/T STEP	PROCEDURE	PANEL	REMARKS
16.5	NOMINAL EGRESS PROCEDURES		
16.5.1	<u>Nominal Egress Preparation</u>		
ALL	Disconnect umbilicals (if suited)		
CP	Neck dams on (if suited)		
AC,DC	Configure center couch - 270° position		
	Armrests folded (stowed)		
16.5.2	<u>Nominal Egress & Power Down</u>		
AC	PL VENT - OFF	15	
DP	Nominal egress panel Config	5	
	cb FLT/PL BUS BAT C - open		
	cb BAT CHRG BAT C/EDS 2 - open		
	cb pnl 275 - all open	275	
	XXXXXXXXXXXXXXXXXXXXXXXXXXXXXXXXXXXXX		
	Post abort panel config		VHF beacon and flashing light left operating to aid CM recovery after an abort.
	PL BCN LT - LO (verify)		
ALL	VHF AM - OFF (ctr)	6,9,10	
DP	VHF AM A(B) - OFF (ctr)	3	
	VHF BCN - ON (verify)		
	cb BAT CHRG BAT C/EDS 2 - open	5	
	XXXXXXXXXXXXXXXXXXXXXXXXXXXXXXXXXXXXX		
CP	Charge hatch counterbalance	Side hatch	
	GN2 ratchet handle - operate		
	GN2 vlv handle - unlock & push		
	outboard		
	Open side hatch (after collar installed)		

NOMINAL EGRESS & POWER DOWN

APOLLO-SOYUZ TEST PROJECT (ASTP)
OPERATIONS HANDBOOK

STA/T STEP	PROCEDURE	PANEL	REMARKS
CP	Lock pin rel knob - UNLOCK Gear box sel - UNLATCH Actr handle sel - U (unlatch) Actr handle rel - push or squeeze Actr handle - operate (until hatch can be opened) Push hatch open Actr handle sel - N (neut) GM2 vlv handle - vent (pull inboard) GM2 vlv handle - press (push outboard) Check pressure gage (mid-white) Repeat vent press cycle as req to obtain mid-white range Egress, inflate life vest, board raft Egress, inflate life vest, board raft Egress, inflate life vest, board raft	Side hatch	Push button or squeeze bar to release actuator handle for operation. Counterbalance vented to mid-white range to assist in securing spacecraft hatch after crew egress.
AC			
DP			
CP			

16.5.2

NOMINAL EGRESS & POWER DOWN

NORMAL BACKUP

APOLLO-SOYUZ TEST PROJECT (ASTP)
OPERATIONS HANDBOOK

STA/T STEP	PROCEDURE	PANEL	REMARKS
17.0	CSM/DM EXPERIMENTS		<p>Technical investigations (experiments) that support science in general or provide engineering, technological, medical, or other data; and technical (in flight) demonstrations of the capabilities of apparatus and/or processes to illustrate or utilize the unique conditions of space flight environment.</p> <p>Establishes basic requirements for guidance, control, and maneuver functions required for experiment operations.</p> <p>Maintain SM RCS single jet control during experiment operations.</p>
17.1	Not Applicable		
17.2	G&C SYSTEMS PREPARATION		
	CMC - on (req), 8.1.3		
	ISS - on & orient known (req), 8.1.3 & 13		
	SCS - on (desired), 8.4.2		
	RCS DAP - load & activate (req), 8.2.1		
AC	Config SM RCS for single jet control	8	
17.3	Not Applicable		
17.4	Not Applicable		
17.5	Not Applicable		

17.2

G&C SYSTEMS PREPARATION

NORMAL BACKLUP

APOLLO-SOYUZ TEST PROJECT (ASTP)
OPERATIONS HANDBOOK

STA/T STEP	PROCEDURE	PANEL	REMARKS
17.6	ULTRAVIOLET ABSORPTION (UVA)		Measures concentrations of atomic oxygen and atomic nitrogen in the atmosphere by optical absorption spectroscopy. Performed with tunnel 1 hatches open to provide drag through cable access from Command Module to docking module.
17.6.1	<u>Connect Drag Thru Cable</u>	230	
DP	Verify cb UVA EXP MNB - open cb UVA COVER MNB - open UVA PWR - OFF UVA LAMPS - OFF UVA COVER - ctr UVA COVER tb - gray Remove UVA PWR J1 dust cap on pnl 230 Obtain UVA drag thru cable from storage. Remove & stow connector dust caps Conn drag thru connector P1 to J1 on pnl 230 (TBD to TBD) Route P2 end of drag thru cable through tunnel 1 to crewman in DM. Remove UV ABSORPTION J2 dust cap on pnl 862 Conn drag thru connector P2 to J2 on pnl 862 (TBD to TBD)	862	
(DM)			

CONNECT DRAG THRU CABLE

APOLLO-SOYUZ TEST PROJECT (ASTP)
OPERATIONS HANDBOOK

STA/T STEP	PROCEDURE	PANEL	REMARKS
DP AC DP	<p>17.6.2 UVA Cover Open (Close)</p> <p>DRAG THRU CABLE connected, 17.6.1 cb UV MNB - close (verify) AUTO RCS B3, C4, & D4 (3) - OFF cb UVA COVER MNB - close UVA COVER - OPEN (CLOSE)</p> <p>UVA COVER tb - gray, -bp(<5 sec), -gray</p> <p>XXXXXXXXXXXXXXXXXXXXXXXXXXXXX X If bp >15 sec cb UVA COVER MNB - open XXXXXXXXXXXXXXXXXXXXXXXXXXXXX X cb UVA COVER MNB - open</p>	<p>274 8 230</p>	<p>Cover must be closed during and remain closed for 15 minutes following spacecraft dumps. Cover must be closed when instrument FOV centerline within 20° of sun.</p> <p>Talkback is barberpole while cover is between full open or full closed, (less than 5 seconds).</p> <p>Contact STDN for further instructions.</p> <p>Provides alignment check of UVA to COAS FOV and star UV reference data accumulation.</p>
AC	<p>17.6.3 UVA/COAS Alignment</p> <p>G&C Syst Prep, 17.2 (req) Opt - on, 8.1.4 COAS PWR - on (up)</p>	15	<p>COAS previously installed and calibrated for IMU alignment at Post Orbital Insertion.</p>
DP	<p>Open UVA COVER, 17.6.2 cb UVA EXP MNB - close UVA PWR - ON</p>	230	<p>Instrument turned on 5 minutes prior to operation for data accumulation to allow star tracking system warmup.</p>
CP	<p>SYS TEST (2) - 1L SYS TEST ind - 0-5 vdc (cycling)</p>	101	<p>UVA EXP POINTING ERROR display. With no return signal, meter cycles between 0 and 5 vdc once per second.</p>

UVA/COAS ALIGNMENT

17.6.3

NORMAL BACKUP

APOLLO-SOYUZ TEST PROJECT (ASTP)
OPERATIONS HANDBOOK

STA/T STEP	PROCEDURE	PANEL	REMARKS
	17.6.4 UVA Operation		
AC	G&C Syst Prep, 17.2 (req) COAS PWR - on (up)	15	
DP	Open UVA COVER, 17.6.2 cb UVA EXP MNB - close UVA PWR - ON UVA LAMPS - ON	230	Lamps must be on for 30 minutes prior to operation for data accumulation.
CP	SYS TEST (2) - 1L VHF AM Ranging Mode, 5.6.4 (V49) mnvr to acq Soyuz reflector Acq Soyuz reflector in COAS Mnvr in yaw to zero reflector in COAS SYS TEST ind - mnvr in pitch to 2.5V, UV pointing signal on meter Mnvr as req for data collection To rotate about a target vector, sel P20, Opt 2, 10.2.1	101	UV EXP POINTING ERROR display. Maneuver using PAD or on-board chart data corrected for UV instrument alignment offset 5.4s. If meter indicates <2.5V, pitch down. If meter indicates >2.5 V, pitch up. Maneuver includes rotating about Soyuz at distances of 150, 500, and 1000 meters with CSM sweep at approximately 3°/min, across Soyuz retro-reflector, while maintaining experiment pointing accuracy.
AC	To translate for subs data collection Close UVA COVER, 17.6.2 AUTO RCS - as req	8	
DP	Reconfigure for data collection when translation complete When data collection complete COAS PWR - OFF VHF RNG - OFF UVA Calibration, 17.6.6	15 3	

UVA OPERATION

17.6.4

NORMAL BACKUP

APOLLO-SOYUZ TEST PROJECT (ASTP)
OPERATIONS HANDBOOK

STA/T STEP	PROCEDURE	PANEL	REMARKS
DP	17.6.5 <u>UVA Deactivation</u> UVA LAMPS - OFF (verify) UVA PWR - OFF Close UVA COVER, 17.6.2	230	
CP	17.6.6 <u>UVA Calibration</u> UVA/COAS Alignment, 17.6.3 UVA Operation, 17.6.4	101	UVA Calibration performed after UVA/COAS alignment and following each UVA operation for data accumulation.
IDP	SYS TEST - LL VHF RNG - OFF (verify) Mnvr off tgt - verify pnl 101 meter cycling Calibration a. Lamps on - covers open (30 sec) UVA LAMPS - ON (verify) UVA COVER - OPEN (verify) b. Lamps on - cover closed (30 sec) UVA COVER - CLOSE c. Lamp off - cover closed (30 sec) UVA LAMPS - OFF d. Lamps off - cover open (30 sec) UVA COVER - OPEN	3 230	Vehicle +X axis about 10° above Soyuz and away from earth.
	17.6.7 <u>Disconnect Drag Thru Cable</u> Verify cb UVA EXP MNB - open cb UVA COVER MNB - open UVA PWR - OFF UVA LAMPS - OFF UVA COVER - ctr UVA COVER tb - gray		Drag thru removed and stowed in preparation for CSM/DM separation.

DISCONNECT DRAG THRU CABLE

APOLLO-SOYUZ TEST PROJECT (ASTP)
OPERATIONS HANDBOOK

STA/T STEP	PROCEDURE	PANEL	REMARKS
DP	Remove drag thru cable from J1 panel 230. Install J1 dust cap. Pass cable thru tunnel for stowage in DM. 17.7 Not Applicable	230	

DISCONNECT DRAG THRU CABLE

17.6.7

NORMAL BACKUP

APOLLO-SOYUZ TEST PROJECT (ASTP)
OPERATIONS HANDBOOK

STA/T STEP	PROCEDURE	PANEL	REMARKS
<p>17.8 STRATOSPHERIC AERSOL MEASUREMENT (SAM)</p> <p>17.8.1 <u>SAM Installation</u></p> <p>Remove SAM from launch stowage and install on dovetail hard mount at RH side window with optic 90° to window plane. Remove J1 and J2 dust caps</p> <p>Obtain SAM coax & pwr cables from stowage. Remove & stow cable dust caps</p> <p>Conn coax connector P2 to J2 on SAM (TBD to TBD)</p> <p>Conn pwr cable connector P1 to J1 on SAM (TBD to TBD)</p> <p>Route P79 end of coax & P2 end of pwr cable to pnl 227</p> <p>Verify</p> <p>cb EXP PWR A - open 5</p> <p>SCI PWR - OFF 227</p> <p>Remove J79 and J85 dust caps, pnl 227</p> <p>Conn coax P79 to (SAM) J79 at pnl 227 (TBD to TBD). Conn pwr cable P2 to J85 on pnl 227 (TBD to TBD)</p> <p>17.8.2 <u>SAM Operation/Data Collection</u></p> <p>G&C System Prep, 17.2</p> <p>SAM Activation</p> <p>Verify SAM Installation, 17.8.1</p>	<p>SAM</p>	<p>MA-007. Measures the concentration and vertical distribution of aerosols in the stratosphere.</p>	

SAM OPERATION/DATA COLLECTION

APOLLO-SOYUZ TEST PROJECT (ASTP)
OPERATIONS HANDBOOK

STA/T STEP	PROCEDURE	PANEL	REMARKS												
DP	<p>cb EXP PWR A - close SCI PWR - on (up) SAM ind lt - on</p> <p>Establish SAM sun LOS orient (P20) opt 1, 10.2.1 (N78 - Gamma = 57.50°, Rho = 31.10°)</p> <p>Mmnvr to SAM att</p> <p>SAM Inflight Alignment Cal</p> <table border="1"> <thead> <tr> <th></th> <th>Y</th> <th>P</th> </tr> </thead> <tbody> <tr> <td>Nominal</td> <td>57.50</td> <td>31.10</td> </tr> <tr> <td>Delta</td> <td>X.XX</td> <td>X.XX</td> </tr> <tr> <td>Final</td> <td>XX.XX</td> <td>XX.XX</td> </tr> </tbody> </table>		Y	P	Nominal	57.50	31.10	Delta	X.XX	X.XX	Final	XX.XX	XX.XX	<p>5 227 SAM</p>	<p>Nominal SAM values.</p> <p>Should be established with sufficient time for calibration and to damp rates to acceptable values prior to data collection.</p> <p>Delta values obtained from SAM inflight calibration target.</p>
	Y	P													
Nominal	57.50	31.10													
Delta	X.XX	X.XX													
Final	XX.XX	XX.XX													
CP	<p>Key V06 N78E Load final Y & P</p> <p>(P20) opt 1, 10.2.1 Mnvr to final SAM att Verify solar disc centered in SAM trgt ring</p>	<p>2,140</p>	<p>SAM photometer LOS should be within +2.0° of sun at start of data collection. Verification that solar disc is centered (inside 2.0° circle) in SAM target ring for initial sunset data collection, will provide adequate onset alignment for time critical sunrise data collection.</p>												

17.8.2

SAM OPERATION/DATA COLLECTION

NORMAL BACKUP

APOLLO-SOYUZ TEST PROJECT (ASTP)
OPERATIONS HANDBOOK

STA/T STEP	PROCEDURE	PANEL	REMARKS
DP	SAM CAL - ON (5-sec)	SAM	Calibration establishes the base and verifies proper installation and cable connection.
AC -00:30 00:00	<p>Null att errors & rates just prior to inhibiting jets</p> <p>CMC MODE - FREE Start Data Collection When data collection complete G&C Control - as reqd SAM Deactivation SCI PWR - OFF SAM ind lt - off</p>	1	<p>Minimum error and rates required to ensure entire solar disc will remain within 10° FOV of photometer during approximate 3-minute data collection period.</p> <p>Inhibit RCS 30-seconds before data collection.</p>
DP	<p>17.8.3 <u>SAM Removal</u></p> <p>Verify cb EXP PWR A - open SCI PWR - OFF Remove coas & pwr cable connectors from J1 & J2 on SAM. Install J1 & J2 dust caps. Remove coas & pwr cable connectors from J79 at pnl 227 & from J85 on pnl 227. Install J79 and J85 dust caps. Stow cables Remove SAM from dovetail hardmount & stow</p>	227 SAM	<p>After final SAM data collection.</p> <p>Cables stowed in DM for CSM/DM separation.</p>

SAM REMOVAL

APOLLO-SOYUZ TEST PROJECT (ASTP)
OPERATIONS HANDBOOK

STA/T STEP	PROCEDURE	PANEL	REMARKS
17.9	MULTIPURPOSE ELECTRIC FURNACE SYSTEM (MEFS)		MA-010. Perform experiments on solidification, crystal growth, and other procedures involving phase changes in various types of materials.
17.9.1	<u>Furnace Evacuation</u> <u>CAUTION</u> Prior to evacuating furnace verify experiment sample cartridges are installed to preclude depressurizing IM thru vent system.		
(DM)	He Isol vlv - CLOSE (verify) He Press vlv - CLOSE (verify) He Vent vlv - CLOSE (verify) Furnace Isol vlv - OPEN Furnace Vent vlv - OPEN He Press vlv - OPEN, then CLOSE	MEFS	To vent DM O2/N2 from He injection cavity.
17.9.2	<u>Furnace He Injection</u> Furnace Vent vlv - CLOSE Furnace Isol vlv - CLOSE He Isol vlv - OPEN, then CLOSE He Press vlv - OPEN, then CLOSE		Helium injection time for each specimen cartridge to be subsequent to illumination of END status indicator or as directed by ground control.

FURNACE HE INJECTION

17.9.1

NORMAL BACKUP

APOLLO-SOYUZ TEST PROJECT (ASTP)
OPERATIONS HANDBOOK

STA/T STEP	PROCEDURE	PANEL	REMARKS
17.9.3	<p><u>Sample Cartridge Prep</u></p>		
(DM)	<p>Furnace Vlv - CLOSE (verify) Furnace Isol vlv - CLOSE (verify) He Vent vlv - OPEN, then CLOSE He Press vlv - OPEN, then CLOSE</p> <p>Retrieve sample cartridge from stowage Install sample cartridge in furnace</p> <p>For MA-060 Experiment Retrieve MA-060 pulser & control cable Install MA-060 pulser on furnace shroud cb GERM CRYG GROWTH MVA - open (verify) GERM CRYG GROWTH PWR - OFF Conn MA-060 cont cable connector P1 to J1 on pnl 862</p> <p>Furnace Evacuation, 17.9.1 Set MEFS Control Param</p>	MEFS	<p>Prior to initial sample processing, He Vent vlv & He Press vlv are opened to vent prelaunch He backfill in furnace.</p> <p>Sequence of sample cartridge processing defined in flight plan.</p> <p>MA-060, Germanium Crystal Growth.</p>
			<p>Set soak setting, soak period, cooldown rate, and RATE RATIO according to Flight Plan tabular data. Approach soak and RATE RATIO settings slowly in CW direction. If desired, turn CCW 1/4 turn and reapproach setting.</p>

SAMPLE CARTRIDGE PREP

APOLLO-SOYUZ TEST PROJECT (ASTP)
OPERATIONS HANDBOOK

STA/T STEP	PROCEDURE	PANEL	REMARKS
(DN)	<p>Select Furnace soak temp</p> <p style="text-align: center;"><u>CAUTION</u></p> <p>Do not select another soak temp during cool down period or --- <u>TBD</u>.</p> <p>Select Furnace soak period</p> <p>Select cool down rate</p> <p>Select RATE RATIO</p> <p>Select control thermocouple pair TC1/TC2</p> <p>TM - 1/2</p> <p>17.9.4 <u>Sample Cartridge Initiate</u></p> <p style="text-align: center;"><u>CAUTION</u></p> <p>Maintain spacecraft control mode that will minimize imparting accelerations to the experiment or disturbance of the sample solidification process will occur.</p>	MEFS	<p>Selectable from 40°C to 1150°C depending upon specific sample cartridge requirements.</p> <p>Selectable from 1 to 64 hours, including manual, depending upon specific sample cartridge requirements.</p> <p>Selectable from passive to 0.6, 1.2, and 2.4°C/minute, depending upon specific sample cartridge requirements.</p> <p>Selects active thermocouple pair for MEFS monitoring (ie., TC1 = H₁/C₁ & TC2 = H₂/C₂).</p> <p>Selects thermocouple pair for CSM PCM processing.</p> <p>CSM overboard dumps are constrained from MEFS initiation through He injection.</p>

SAMPLE CARTRIDGE INITIATE

17.9.4

NORMAL BACKUP

APOLLO-SOYUZ TEST PROJECT (ASTP)
OPERATIONS HANDBOOK

STA/T STEP	PROCEDURE	PANEL	REMARKS
CMC (SCS) Min Impulse, 7.1.5 (7.1.2)			CSM minimum impulse single jet attitude control mode from initiation through He injection imparts minimum vehicle acceleration to the experiment.
DP	Verify Sample Cartridge Prep, 17.9.3 cb DM FURNACE/CRYS GROWTH (3) - close	274	
(DM)	For MA-060 Experiment cb GERM CRYG GROWTH MNA - close GERM CRYG GROWTH PWR - ON POWER - ON START - START (mom)	862 MEFS	
17.9.5	<u>Sample Cartridge Termination</u>		
	FURNACE COOL It - on (verify) START - OFF POWER - OFF		Touch temperature of furnace is less than 46°C.
	For MA-060 Experiment GERM CRYG GROWTH PWR - OFF cb GERM CRYG GROWTH MNA - open MA-060 Pulser Cont Cable - disconn Remove & stow pulser & cont cable	862	
	Equalize DM/furnace pressure He Press vlv - close (verify) Furnace Isol vlv - OPEN Furnace Vent vlv - OPEN (5 sec), then CLOSF Furnace Isol vlv - CLOSE	MEFS	Purge He from furnace and lines.

SAMPLE CARTRIDGE TERMINATION

APOLLO-SOYUZ TEST PROJECT (ASTP)
OPERATIONS HANDBOOK

STA/T STEP	PROCEDURE	PANEL	REMARKS
(DM)	He Press vlv - OPEN He Vent vlv - OPEN (5 sec), then CLOSE He Press vlv - CLOSE 17.9.6 <u>Furnace Lamp Test</u> POWER - ON (verify) LAMP TEST - 1 STATUS LAMPS (8) - on LAMP TEST - 2 STATUS LAMPS (8) - on LAMP TEST - OFF POWER - OFF	MEFS	Repressurize furnace with DM atmosphere.
17.9.7	<u>Sample Cartridge Temp Verification</u> Sample Cartridge Initiate, 17.9.4 CARTRIDGE TEMP - HOT 1/HOT 2 (DIGITAL READOUT 0-1150°C) CARTRIDGE TEMP - COLD 1/COLD 2 (DIGITAL READOUT 0-200°C)		On board verification of MEFS sample cartridge process temperature.

17.9.7

SAMPLE CARTRIDGE TEMP VERIFICATION

NORMAL BACKUP

APOLLO-SOYUZ TEST PROJECT (ASTP)
OPERATIONS HANDBOOK

STA/T STEP	PROCEDURE	PANEL	REMARKS
17.10	ELECTROPHORESIS EXPERIMENT (EPE)		MA-014. ELECTROPHORESIS-GERMAN Experiment. Investigates possibilities of improved performance of free flow electrophoresis process in the absence of gravity.
17.10.1	<u>EPE Preparation</u>		Verifies prelaunch EPE cooling of ECS secondary cooling loop and reconfigures for evaporative cooling prior to EPE Initiate.
DP	cb ELECTROPHORESIS (2) - close (verify)	274	
CP	FREEZER POWER - ON (verify)	EPE	Freezer power must be on at all times. Samples are in freezer.
	SAMPLE TEMP - 0-4°C (verify)	382	
	SUIT HT EXCH SEC GLY - BYP	303	
	SEC CAB TEMP vlv - OFF (ccw)	377	
	GLY TO RAD SEC vlv - BYP (verify)	382	
	SEC EVAP H2O CONT - AUTO	2	
	SEC EVAP H2O FLOW - AUTO		
	ECS IND sel - SEC		
	SEC COOL PUMP - AC2 (verify)		
	SEC GLY DISCH PRESS ind - 39-52 psig		
	SEC ACCUM QTY ind - 30-60%		
	SEC COOL EVAP - EVAP		
	SEC GLY EVAP STM PRESS ind -		
	0.09-0.14 psia (when boiling)		
	>0.14 psia (not boiling)		
	After 5 min		
	SEC GLY EVAP OUT TEMP ind - 40-45°F		
	EPE COOLING - COOL (ccw) (verify)	165	For EPE Initiate, SEC GLY EVAP OUT TEMP must be 40-45°F.

EPE PREPARATION

APOLLO-SOYUZ TEST PROJECT (ASTP)
OPERATIONS HANDBOOK

STA/T STEP	PROCEDURE	PANEL	REMARKS
17.10.2	<p><u>EPE Initiate</u></p> <p><u>CAUTION</u></p> <p>Maintain spacecraft control mode that will minimize imparting accelerations to the experiment or acceleration induced sedimentation and thermal convection will occur.</p> <p>CMC (SCS) Min Impulse, 7.1.5 (7.1.2)</p> <p>Verify EPE Preparation, 17.10.1</p> <p><u>CAUTION</u></p> <p>Initiation of sample is irreversible for that sample.</p> <p>Remove samples (1, 2, or 3) from EPE receptacle or sample from MA-011 freezer and install in SAMPLE INLET</p> <p>EPE POWER - ON Verify Standby Status STANDBY lt - on FLUID NO/GO lt - out CHAMBER NO/GO lt - out RECORDER NO/GO lt - out SEQUENCE START pb - push Verify Sequence PRE RUN lt - on 200 sec</p>	EPE	<p>CSM minimum impulse single jet attitude control mode during EPE operations imparts minimum vehicle accelerations to the experiment.</p>

EPE INITIATE

17.10.2

NORMAL BACKUP

APOLLO-SOYUZ TEST PROJECT (ASTP)
OPERATIONS HANDBOOK

STA/T STEP	PROCEDURE	PANEL	REMARKS
CP	<p>STEP 1 lt - on 100 sec STEP 2 lt - on 100 sec STEP 3 lt - on 150 sec POST RUN lt - on 150 sec SEQUENCE RESET pb - push STANDBY lt - on (verify) Remove sample from SAMPLE INLET, return to receptacle and install next sample into SAMPLE INLET</p>	EPE	Freezer may be turned off following processing of last stored sample.
17.10.3	EPE Termination	EPE	
CP	<p>EPE POWER - OFF FREEZER POWER - OFF (only after last sample) SEC COOL EVAP - RSET 1 min, then off (ctr)</p>	2	
	SEC EVAP H2O FLOW - OFF	382	
	SEC EVAP H2O CONT vlv - OFF	2	
	SEC COOL PUMF - off (ctr)	382	
	ECS IND sel - PRIK	303	
	SUIT HT EXCH SEC GLY - FLOW	165	Reference NASA Storage Document TBD.
	SEC CAB TEMP vlv - as desired		
	EPE COOLING - BYPASS (cw) (Tool E)		
17.10.4	EPE Lamp Test		
DP	cb ELECTROPHORESIS (2) - close (verify)	274	
CP	<p>FREEZER POWER - ON (verify) EPE POWER - ON (verify) STANDBY lt - on (verify) LAMP CHECK - depress, then release all lts - on, then out (verify) EPE POWER - OFF STANDBY lt - out</p>	EPE	

EPE LAMP TEST

APOLLO-SOYUZ TEST PROJECT (ASTP)
OPERATIONS HANDBOOK

STA/T STEP	PROCEDURE	PANEL	REMARKS
17.11	ELECTROPHORESIS TECHNOLOGY EXPERIMENT (ETE)		MA-011. ELECTROPHORESIS - U.S.A. Experiment. Test new techniques for performing electrophoresis demonstrations in space flight.
17.11.1	<u>ETE Preparation</u>		
CP	<p>Obtain power cable from storage. Remove & stow connector dust caps. cb ETE AC2 (3) - open (verify) ETE PWR - OFF (verify) Conn power cable connector P2 to J2 on pnl 230 (TBD to TBD). Route P1 cable end across LEB to ETE Conn P1 connector to J1 on ETE (TBD to TBD) Lift ETE cover & lock upright POWER - OFF (verify) TEMP SELECT - OFF (verify) MODE SELECT - OFF (verify) cb ETE AC2 (3) - close ETE PWR - ON</p>	274 230 ETE 274 230	
DP CP	<p>Obtain 70 mm HEDC, 80 mm lens, lens extdr, film pack, & IVL from storage Config camera & attach to ETE cover brkt Obtain freezer from storage & position near ETE</p>	ETE	

ETE PREPARATION

17.11.1

NORMAL BACKUP

APOLLO-SOYUZ TEST PROJECT (ASTP)
OPERATIONS HANDBOOK

STA/T STEP	PROCEDURE	PANEL	REMARKS
17.11.2	<p><u>ETE Operation - Electrophoresis/Isotachophoresis</u></p> <p><u>CAUTION</u></p> <p>Maintain spacecraft control mode that will minimize imparting accelerations to the experiment or acceleration induced sedimentation and thermal convection will occur.</p> <p>CMC (SCS) Min Impulse, 7.1.5 (7.1.2)</p> <p>ETE Preparation, 17.11.1</p> <p>Retrieve numbered column from ETE stowage comp't & place on thermoelectric cradle</p> <p>Clamp column in place. Attach fluid connection to each electrode</p> <p>Connect electrical plug</p> <p>Remove numbered sample slide from freezer & insert into column</p>	ETE	<p>CSM minimum impulse single jet attitude control mode during ETE operations imparts minimum vehicle accelerations to the experiment.</p> <p>ETE columns and sample slides are numbered and are required to be processed in order defined by flight plan:</p> <ol style="list-style-type: none"> 1. Isotach of fixed red blood cells 2. Electro of fixed red blood cells 3. Electro of lymphocytes 4. Electro of kidney cells 5. Electro of kidney cells 6. Electro of lymphocytes 7. Electro of fixed red blood cells 8. Isotach of fixed red blood cells

ETE OPERATION - ELECTROPHORESIS/ISOTACHOPHORESIS

APOLLO-SOYUZ TEST PROJECT (ASTP)
OPERATIONS HANDBOOK

STA/T STEP	PROCEDURE	PANEL	REMARKS
CP	<p>POWER - ON If Electrophoresis, initiate cooling TEMP SELECT - COOL TIMER SELECT - 60 If Electrophoresis, verify cooling COLUMN TEMP - +4°C</p> <p>CURRENT SELECT - HI (lymphocytes) or LO (kidney or red blood cells) Initiate photography MODE SELECT - ELECTRO (electrophoresis) or ISCTACH (Isotachophoresis) Observe & RCD position of electrophoresis bands or isotachophoresis bands MODE SELECT - OFF</p> <p>If Electrophoresis, perform freeze THERMO SELECT - FREEZE 30 min, then OFF</p> <p>POWER - OFF Discontinue photography Disconn electrical plug & remove fluid connections from each electrode</p> <p>If Electrophoresis Unclamp column & twist off each electrode Place frozen column in freezer & place electrode ends in ETE stowage comp't</p>	ETE	<p>Approximately 10 minutes required to cool column to +4°C.</p> <p>HI position for lymphocytes and LO position for kidney cells and red blood cells.</p> <p>Conduct electrophoresis or isotachophoresis for 60 minutes. Timer activates audible signal at completion.</p> <p>Conduct freeze cycle for 30 minutes.</p>

17.11.2

ETE OPERATION - ELECTROPHORESIS/ISOTACHOPHORESIS

NORMAL BACKUP

APOLLO-SOYUZ TEST PROJECT (ASTP)
OPERATIONS HANDBOOK

STA/T STEP	PROCEDURE	PANEL	REMARKS
CP	If Isotachophoresis Unclamp column & return assembled column to ETE storage comp't	ETE	
	<u>17.11.3 ETE Termination</u>		
DP	ETE PWR - OFF	230	
CP	cb ETE AC2 (3) - open Disconnect power cable from ETE & from J2 on pnl 230. Restow Return freezer to stowage Disassemble camera equipt & return to stowage locations Close ETE cover	274 230	
		ETE	

ETE TERMINATION

APOLLO-SOYUZ TEST PROJECT (ASTP)
OPERATIONS HANDBOOK

STA/T STEP	PROCEDURE	PANEL	REMARKS
17.12	LIGHT FLASH (LF)		MA-106. Obtains data on the visual light flash phenomenon. During 90 minute manned period of data recording, angle between astronaut LOS and zenith to remain constant within 5-degrees. Additionally, while in the South Atlantic Anomaly (SAA), Astro LOS will be parallel to the earths magnetic lines of force within 5-degrees, and in a direction away from earth. Period within the SAA expected to be ≈5-minutes.
17.12.1	LF Preparation		
	Obtain Power/Control Logic box, detector amplifier boxes, cables, & masks from storage		
	Position power/control logic box on center couch		
	Position detector amplifier boxes on right & left couch headframe		
	Interconn power/contr logic box, detector amplifier boxes, & mask assemblies. Cable connectors (TBD to TBD)		
	cb UTIL LEB MNB - open (verify)	5	
	UTIL PWR - OFF (verify)	100	Three cables for each crewman (event, detector, mask cables).
	Conn power/contr logic box cable P1 connector to J5 on pnl 100 (TBD to TBD)		
	Config LF Data Recorder If manned LF operation	LF	Intra crew communication required during experiment data gathering. Monitoring crewman operates experiment equipment and accomplishes experiment related support functions.
	Don light weight headsets		Observing crewmen identify light flash occurrences.
	Config comm for voice record, 5.6.7		
	Obs crewmen ingress Rt & left couches		
	Mon crewman install window shades & config for minimum ltg		

LF PREPARATION

17.12.1

NORMAL BACKUP

APOLLO-SOYUZ TEST PROJECT (ASTP)
OPERATIONS HANDBOOK

STA/T STEP	PROCEDURE	PANEL	REMARKS
(P20) opt 5, mnvr to LF att, 10.2.1			Attitude for LF experiment defined as CSM in retro-grade position with -Z axis rotated 60° from zenith (+X axis 30° from zenith), and XZ plane rotated 35° from orbital plane such that +X axis is rotated towards North. Ground track passes through SAA are NW to SE (descending passes).
17.12.2 LF Operation (Manned)			Flight plan will define specific orbital time to initiate manned operation.
CP	Verify LF Preparation, 17.12.1 Obs crewmen don light tight masks Mon crewman config exper pnls DARK ADAPTATION (4) - OFF (verify) LF POWER - OFF (verify) 5 cb UTIL LEB MNB - close 100 UTIL PWR - on (up) LF POWER - DARK ADAPT, Record time POWER lamp - on (verify) TAPE RECORDER lamp - on (verify)		Monitoring crewman enters start time, dark adaptation levels, and phenomena visual detection in written logs. Integral tape recorder activated with LF power on.
	DARK ADAPTATION (4) - as req		Dark adaptation is determined by monitoring crewman by selection of crewman 1/crewman 2 for each level of dark adaptation (1 thru 4) over a 20 minute period.
	POWER - DET 1 for ~23 min, then 2, etc		Monitoring crewman positions detector select every 23 minutes, from 1 through 4 (total 92 minutes).
	POWER - OFF DARK ADAPTATION (4) - OFF UTIL PWR - OFF	100	Dark adaptation is periodically verified with DARK ADAPTATION. If unmanned operation immediately follows, utility power is left on.

LF OPERATION (MANNED)

APOLLO-SOYUZ TEST PROJECT (ASTP)
OPERATIONS HANDBOOK

STA/T STEP	PROCEDURE	PANEL	REMARKS
17.12.3	<p><u>LF Operation (Unmanned)</u></p> <p>Verify LF Preparation, 17.12.1</p> <p>Position mask assemblies & detector amplifier boxes on Rt & left couch head rests</p> <p>Position pwr/contr logic box on ctr couch</p> <p>cb UTIL LEB MNB - close (verify)</p> <p>UTIL PWR - on (up)</p> <p>DARK ADAPTATION (4) - OFF</p> <p>POWER - DARK ADAPT, Record time</p> <p>POWER lamp - on (verify)</p> <p>TAPE RECORDER lamp - on (verify)</p> <p>POWER - OFF</p> <p>UTIL PWR - OFF</p>	<p>5</p> <p>100</p> <p>LF</p>	<p>Flight plan will define specific orbital time to initiate unmanned operation.</p> <p>For unmanned operation, the interconnected mask assemblies and detector amplifier boxes are placed on the right and left couch head rests for data gathering.</p> <p>Monitoring crewman enter start time.</p> <p>As directed by ground control or flight plan.</p>
17.12.4	<p><u>LF Disassembly</u></p> <p>POWER - OFF (verify)</p> <p>UTIL PWR - OFF (verify)</p> <p>cb UTIL LEB MNB - open</p> <p>Disconn cable assy's from power/control logic box, detector amplifier boxes, mask assemblies, and CSM pnl 100, J5</p> <p>Retrieve tape cassette from power/control box</p> <p>Stow cassette, detector amplifier boxes, mask assy's & written logs for return stowage</p> <p>Stow cable assys, & power/contr box for DM off loading</p>	<p>LF</p> <p>100</p> <p>5</p>	

LF DISASSEMBLY

17.12.4

NORMAL BACKUP

APOLLO-SOYUZ TEST PROJECT (ASTP)
OPERATIONS HANDBOOK

STA/T STEP	PROCEDURE	PANEL	REMARKS
17.13	CRYSTAL GROWTH EXPERIMENT (CGE)		MA-028. Determines if crystals can be grown by diffusion through water in zero gravity conditions.
	<p style="text-align: center;"><u>CAUTION</u></p> <p>After activating experiment, maintain spacecraft control mode that will minimize imparting accelerations to the experiment or disturbance will occur of the reactor solution diffusion process leading to crystal formation.</p>		
17.13.1	<u>Crystal Growth Activation</u>		
CP	<p>Open U4 locker doors & restrain in open position</p> <p>Open Reactor Chamber Valves</p> <p>Rotate knurl knob lock (CCW) to free key handle on each end of reactor chamber</p> <p>Rotate key handle -3 turns (CCW) to full open</p> <p>Rotate knurl knob lock (CW) finger tight to secure valve in open position</p> <p>Repeat proced for 5 other reactors</p>	U4 CGE	<p>Six reactors, each having two valves. Lock frees key handle for valve opening.</p> <p>Three revolutions stop to stop.</p>

CRYSTAL GROWTH ACTIVATION

APOLLO-SOYUZ TEST PROJECT (ASTP)
OPERATIONS HANDBOOK

STA/T STEP	PROCEDURE	PANEL	REMARKS
CP	<p>XXXXXXXXXXXXXXXXXXXXXXXXXXXXXXXXXXXXX</p> <p>If lock cannot be turned by hand Use spanner tool #(TBD) Rotate lock (CCW) to loosen If valve cannot be opened by hand</p> <p style="text-align: center;"><u>CAUTION</u></p> <p>Do not force key handle if lock is not backed off.</p> <p>Use spanner tool #(TBD) Rotate key handle (CCW) -3 turns to full open Rotate knurl knob lock (CW) to secure valve in open position</p> <p>XXXXXXXXXXXXXXXXXXXXXXXXXXXXXXXXXXXXX</p>	CGE	Spanner tool (TBD) in U4, used to unseat knurl knob locks or key handles.
	Close U4 locker doors	U4	Doors closed carefully to avoid imparting accelerations to the reactors.
17.13.2	<u>Photographic Observations</u>	100	Reaction process to be photographed at 6 to 10 hour intervals three times per day following activation
	Obtain 35 mm camera from stowage	CGE	
	Open U4 locker doors & restrain in open position	100	
	FLOOD LTS - full BFT (cw)		
	Adjust LH mirror to illuminate cryst growth reactors		
	Photograph reactors		
	Close U4 locker doors		
	Restow camera		
	FLOOD LTS - as req	100	
17.14	Not Applicable		

PHOTOGRAPHIC OBSERVATIONS

17.13.2

NORMAL BACKUP

APOLLO-SOYUZ TEST PROJECT (ASTP)
OPERATIONS HANDBOOK

STA/T STEP	PROCEDURE	PANEL	REMARKS
17.15	EARTH OBSERVATION		MA-136. Observe and photograph earth features.
	Configure G&C, 17.2		
	(P20) opt 5, 10.2.1		Provides required pointing for visual observations of earth features and for photographic mapping of targets of prime scientific interest, and other photographs in support of visual observations.

EARTH OBSERVATION

APOLLO-SOYUZ TEST PROJECT (ASTP)
OPERATIONS HANDBOOK

STA/T STEP	PROCEDURE	PANEL	REMARKS
17.16 SOLAR ECLIPSE	Configure G&C, 17.2 (V49) mmvr to undock att, 8.3.4 Set DAC for photos Align COAS on docking trgt Configure RCS, 7.1.1 Configure Dock System for sep, 18.1.2 Verify Dock System lts Undock (sunrise +1.5 min) THC (4 jet) -X (-3 sec) Verify sep rate -1 m/sec DAC - operate (-5 min) THC - +X (null Klation rates)	2	MA-148 (AS-4). Test new methods of studying solar corona and contamination surrounding spacecraft. -XD6 axis toward sun. Attitude hold accuracy, P ± 0.7°, R ± 1.0°.
CP			At undocking, +Z _{A4} and -Y _{C5} axes in plane defined by spacecraft, Earth and Sun.

17.16

SOLAR ECLIPSE

NORMAL BACKUP

**APOLLO-SOYUZ TEST PROJECT (ASTP)
OPERATIONS HANDBOOK**

STA/T STEP	PROCEDURE	PANEL	REMARKS												
18.0	APOLLO - SOYUZ OPERATIONS														
18.1	DOCKING MODULE/SOYUZ DOCKING AND UNDOCKING - CM ACTIVE														
	<p>This section contains the procedural requirements for docking and undocking with the Soyuz with the CM Docking System in the active mode. (See figure 18-1 for status lights logic.)</p>														
	<p align="center">MANEUVERS</p>														
	<p>Deactivate glycol evaporator prior to 1000 ft from Soyuz</p>														
	<p>GLY EVAP STM AUTO - MAN</p>														
	<p>GLY EVAP STM INCR - INCR for 58 sec min</p>	2													
18.1.1	<u>Docking With Soyuz, CM Active</u>														
1	<p>The following are req CMC - on, 8.1.3 COAS - installed and calib, 13.1.8 SCS - on, 8.4.2 ISS - on & orient known, 8.1.3 & sec 14 RCS DAP load & activate, 8.2.1 R1 - 611XX Moun 46 display R2 - X1111 </p>		<p>At initiation of procedure, CSM shall be 15 to 50 feet from Soyuz properly aligned and in formation flight.</p> <p>Provides G&N control capability.</p> <p>Provides SCS control capability.</p> <p>Establishes G&N control capability as follows: CSM configuration, 4 quad translation (quads A, B, C, D - on).</p> <p>This maneuver should be performed in the following attitude and rate deadbands in either CMC or SCS control modes to simplify control task during docking.</p>												
			<table border="1"> <thead> <tr> <th></th> <th>CMC</th> <th>SCS</th> </tr> </thead> <tbody> <tr> <td>ATT DBD</td> <td>+0.5° (R03)</td> <td>+0.2° (MIN)</td> </tr> <tr> <td>RATE DBD</td> <td>+0.2°/sec (fixed)</td> <td>+0.2°/sec (LO)</td> </tr> <tr> <td>RATE CMD (RHC)</td> <td>+0.5°/sec (R03)</td> <td>+0.65°/sec</td> </tr> </tbody> </table>		CMC	SCS	ATT DBD	+0.5° (R03)	+0.2° (MIN)	RATE DBD	+0.2°/sec (fixed)	+0.2°/sec (LO)	RATE CMD (RHC)	+0.5°/sec (R03)	+0.65°/sec
	CMC	SCS													
ATT DBD	+0.5° (R03)	+0.2° (MIN)													
RATE DBD	+0.2°/sec (fixed)	+0.2°/sec (LO)													
RATE CMD (RHC)	+0.5°/sec (R03)	+0.65°/sec													

18.1.1

DOCKING WITH SOYUZ, CM ACTIVE

NORMAL BACKUP

APOLLO-SOYUZ TEST PROJECT (ASTP)
OPERATIONS HANDBOOK

STA/T STEP	PROCEDURE	PANEL	REMARKS
AC	Set SCS att controls THC PWR - on (up) RHC PWR DIR (both) - MNA/MNB CMC MODE - HOLD DBD/RATE - MIN/LO ATT DBD - MIN RATE - LO LI: CYCLE - OFF BFAG MODE (3) - ATT 1/RATE 2 MAN ATT (3) - RATE CMD SC CONT - CMC THC - ARMED RHC (both) - ARMED	1	Enables direct RCS coils for contingency takeover.
CP DP	2 Verify control status for docking COAS PWR - on (up) EXT REMDZ LTS - SPOT Docking System A cb DS A IND LOGIC MNA - close cb DS A IND PWR AC1 - close cb DS A CONTROL BAT A - close cb DS A MOTORS AC1 (3) - close cb DM POWER (2) - close (verify) Docking System B cb DS B IND LOGIC MNB - close cb DS B IND PWR AC2 - close cb DS B CONTROL BAT B - close cb DS B MOTORS AC2 (3) - close	15 274	

DOCKING WITH SOYUZ, CM ACTIVE

APOLLO-SOYUZ TEST PROJECT (ASTP)
OPERATIONS HANDBOOK

STA/T STEP	PROCEDURE	PANEL	REMARKS
3	Docking System Config for CM Active Docking PASSIVE lt - on (verify) STRUCT LATCH OPEN lt - on (verify)	2	Refer to CM ACTIVE/PASSIVE POS status lts, Fig 18-1.
CP	<p style="text-align: center;"><u>CAUTION</u></p> Guide ring EXTND/RETR must be operated on system A or B only (single motor). Dynamic forces using two motors could create loads in the structure beyond design limits.		System A only to be used. Guide ring fully extended in approximately 60 seconds.
AC	GUIDE RING A - EXTND GUIDE RING EXTEND lt - on PASSIVE lt - out GUIDE RING A - off (ctr)		Indicates guide ring extended and ready for soft dock - GUIDE RING EXTEND lt on required for soft dock. Refer to CSM ACTIVE/GUIDE RING FULLY EXTND status lts, Fig. 18-1.
4	Initiate Capture THC - initiate to close at 0.2 to 0.4 fps RHC - maintain min relative alignment angles with the Soyuz. Maintain angular rates ≤ 0.2 deg/sec		

DOCKING WITH SOYUZ, CM ACTIVE

APOLLO-SOYUZ TEST PROJECT (ASTP)
OPERATIONS HANDBOOK

STA/T STEP	PROCEDURE	PANEL	REMARKS
AC	THC - initiate translation thrust (4 thrusters) +XA5 direction after initial contact (0.5 sec max)	2	Stop translation thrust in the +XA5 direction a maximum of 0.5 sec after capture. GUIDE RING CAPTURE lt indicates capture of all three latches.
CP	GUIDE RING CAPTURE lt - on		Refer to CM ACTIVE/CAPTURED status lts, Fig 18-1. GUIDE RING CAPTURE lt on, before initiating guide ring retract.
5	Spacecraft alignment achieved Initiate Guide Ring Retract GUIDE RING A - RETR GUIDE RING EXTEND lt - out		System A only to be used. Guide ring fully retracted in approximately 50 seconds.
6	STRUCT RING CONTACT lt - on GUIDE RING A - off (ctr) Structural Latch Preload		Refer to CM ACTIVE/RETR & INTERFACE CONTACT status lts, Fig 18-1. Indicates interface seal contact (required for structural latch preload). 2 seconds minimum after STRUCT RING CONTACT lt - on.
	<u>CAUTION</u> Structural latches CLOSE must be operated by system A or B only (single motor). Stalled gear box load using two motors could exceed system cable breaking strength.		
	<u>NOTE</u> STRUCT LATCH CLOSE lt may flicker due to delay in relay lockup.		

18.1.1

DOCKING WITH SOYUZ, CM ACTIVE

NORMAL BACKUP

APOLLO-SOYUZ TEST PROJECT (ASTP)
OPERATIONS HANDBOOK

STA/T STEP	PROCEDURE	PANEL	REMARKS
CP	STRUCT LATCH A - CLOSE STRUCT LATCH OPEN lt - out STRUCT LATCH CLOSE lt - on STRUCT LATCH A - off (ctr)	2	System A only to be used. Structural active latches (8) locked in approximately 8 seconds. Indicates hard dock. Load cell verification provided in DM via selector switches (panel 856) and meters for an additional verification of structural latches locked. Refer to CM ACTIVE/STRUCT LATCH CLOSED (DOCKED) status lts, Fig 18-1. Guarded.
	<u>CAUTION</u>		
	Safing of Docking System must be performed, to prevent inadvertent undocking.		
7	Safe Docking System Docking System A cb DS A CONTROL BAT A - open cb DS A MOTORS AC1 (3) - open Docking System B cb DS B CONTROL BAT B - open cb DS B MOTORS AC2 (3) - open GUIDE RING (2) - off (ctr) (verify) STRUCT LATCH (2) - off (ctr) (verify) EXT RNDZ LTS - OFF (ctr) COAS PWR - OFF	274 2 274 15	Guarded.
8	Postdocking pnl config Prepare for CSM/DM Docked operations, Appendix A		

DOCKING WITH SOYUZ, CM ACTIVE

APOLLO-SOYUZ TEST PROJECT (ASTP)
OPERATIONS HANDBOOK

STA/T STEP	PROCEDURE	PANEL	REMARKS
CP	CAPTURE LATCH (2) - RELEASE GUIDE RING CAPTURE lt - out PASSIVE lt - on STRUCT RING CONTACT lt - out STRUCT LATCH A - off (ctr) Verify Undocking	2	Less than 1 second. System A and B simultaneously. Guide ring positions from active docked retract position to fully retracted (passive) position. Refer to CM ACTIVE/VEH SEP (NORM REL) status lts, Fig 18-1.
DP	3 Post Final Undocking Pnl config Docking System A cb DS A IND LOGIC MNA - open cb DS A IND PWR ACL - open cb DS A CONTROL BAT A - open cb DS A MOTORS ACL (3) - open Docking System B cb DS B IND LOGIC MNB - open cb DS B IND PWR AC2 - open cb DS B CONTROL BAT B - open cb DS B MOTORS AC2 (3) - open Docking System Status lights (all) - out	274	
CP			

18.1.1.2

UNDocking WITH SOYUZ, CM ACTIVE

NORMAL BACKUP

APOLLO-SOYUZ TEST PROJECT (ASTP)
OPERATIONS HANDBOOK

STA/T STEP	PROCEDURE	PANEL	REMARKS												
18.2	DOCKING MODULE/SOYUZ DOCKING AND UNDOCKING - CM PASSIVE														
	<p>This section contains the procedural requirements for docking and undocking with the Soyuz with the CM Docking system in the passive mode. (See Figure 18-1 for status lights logic.)</p>														
	<p>MANEUVERS</p>														
	<p>Deactivate glycol evaporator prior to 1000 ft from Soyuz GLY EVAP STM AUTO - MAN GLY EVAP STM INCR - INCR for 58 sec min</p>	2													
	<p>18.2.1 <u>Docking With Soyuz, Apollo DM Passive</u></p>		<p>At initiation of procedure, CSM shall be 25 to 50 feet from Soyuz properly aligned and in formation flight.</p>												
	<p>1 The following are req CMC - on, 8.1.3 COAS - installed & calib 14.1.8 SCS - on, 8.4.2 ISS - on & orient known, 8.1.3 & sec 14 RCS DAP load & activate, 8.2.1 R1 - 611XX Noun 46 display R2 - X1111 </p>		<p>Provides G&N control capability. Provides SCS control capability.</p>												
	<p>AC</p>		<p>Establishes G&N control capability as follows: CSM configuration, 4 quad translation (quads A, B, C, D - on).</p>												
			<p>This maneuver should be performed in the following attitude and rate deadbands in either CMC or SCS control modes to simplify control task during docking.</p>												
	<table border="1"> <thead> <tr> <th></th> <th>CMC</th> <th>SCS</th> </tr> </thead> <tbody> <tr> <td>ATT DBD</td> <td>+0.5° (RO3)</td> <td>+0.2° (MIN)</td> </tr> <tr> <td>RATE DBD</td> <td>+0.2°/sec (fixed)</td> <td>+0.2°/sec (LO)</td> </tr> <tr> <td>RATE CMD (RHC)</td> <td>+0.5°/sec (RO3)</td> <td>+0.65°/sec</td> </tr> </tbody> </table>		CMC	SCS	ATT DBD	+0.5° (RO3)	+0.2° (MIN)	RATE DBD	+0.2°/sec (fixed)	+0.2°/sec (LO)	RATE CMD (RHC)	+0.5°/sec (RO3)	+0.65°/sec		
	CMC	SCS													
ATT DBD	+0.5° (RO3)	+0.2° (MIN)													
RATE DBD	+0.2°/sec (fixed)	+0.2°/sec (LO)													
RATE CMD (RHC)	+0.5°/sec (RO3)	+0.65°/sec													

DOCKING WITH SOYUZ, APOLLO DM PASSIVE

APOLLO-SOYUZ TEST PROJECT (ASTP)
OPERATIONS HANDBOOK

STA/T STEP	PROCEDURE	PANEL	REMARKS
AC	Set SCS att controls THC PWR - on (up) RHC PWR DIR (both) - MNA/MNB CMC MODE - HOLD DBD/RATE - MIN/LO ATT DBD - MIN RATE - LO LIM CYCLE - OFF BMAG MODE (3) - ATT 1/RATE 2 MAN ATT (3) - RATE CMD SC CONT - CMC THC - ARMED RHC (both) - ARMED	1	Enables direct RCS coils for contingency takeover.
DP	2 Verify control status for docking COAS PWR - on (up) EXT RNDZ LTS - SPOT Docking System A cb DS A IND LOGIC MNA - close cb DS A IND PWR AC1 - close cb DS A CONTROL BAT A - close cb DS A MOTORS AC1 (3) - close cb IM POWER (2) - close (verify) Docking System B cb DS B IND LOGIC MNB - close cb DS B END PWR AC2 - close cb DS B CONTROL BAT B - close cb DS B MOTORS AC2 (3) - close	15 274	

18.2.1

DOCKING WITH SOYUZ, APOLLO IM PASSIVE

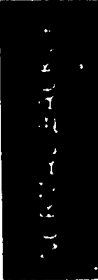

APOLLO-SOYUZ TEST PROJECT (ASTP)
OPERATIONS HANDBOOK

STA/T STEP	PROCEDURE	PANEL	REMARKS
3 CP	<p>Docking System Config for CM Passive Docking STRUCT LATCH OPEN lt - on (verify) PASSIVE lt - on (verify)</p>	2	<p>Verifies guide ring retracted, body latches closed and passive hooks closed. Refer to CM PASSIVE/PASSIVE POS status lts, Fig 18-1.</p>
4 AC	<p>Initiate Capture THC - initiate to close at 0.2 to 0.4 fps RHC - maintain min relative alignment angles with the Soyuz. Maintain angular rates < 0.2 deg/sec Initial contact - "Attitude hold - narrow dead band" THC - initiate translation thrust (4 thrusters) +XA5 direction after initial contact, stop translation thrust (max of 0.5 seconds after capture).</p>		<p>Indicates Soyuz capture of all three body mounted latches. Refer to CM PASSIVE/CAPTURED status lts, Fig 18-1. Soyuz crew transmit retract information to Apollo crew.</p>
	<p>GUIDE RING CAPTURE lt - on Soyuz Guide Ring Retract</p>	Soyuz	<p>Indicates Soyuz guide ring has retracted and interface ring contact has been made. Refer to CM PASSIVE/RETR & INTERFACE CONTACT status lts, Fig 18-1.</p>
	<p>STRUCT RING CONTACT lt - on Soyuz initiate structural latch preload</p>	2 Soyuz	<p>Soyuz structural latch preload information transmitted to Apollo crew.</p>

DOCKING WITH SOYUZ, APOLLO DM PASSIVE

APOLLO-SOYUZ TEST PROJECT (ASTP)
OPERATIONS HANDBOOK

STA/T STEP	PROCEDURE	PANEL	REMARKS
	<p style="text-align: center;"><u>CAUTION</u></p> <p>Safing of Docking System must be performed to prevent inadvertent undocking.</p>		
5	<p>Safe Docking System</p> <p>Docking System A</p> <p>cb DS A CONTROL BAT A - open</p> <p>cb DS A MOTORS AC1 (3) - open</p> <p>Docking System B</p> <p>cb DS B CONTROL BAT B - open</p> <p>cb DS B MOTORS AC2 (3) - open</p> <p>EXT RNDZ LTS - OFF</p> <p>COAS PWR - OFF</p>	274	
6	<p>Postdocking pnl config</p> <p>Prepare for CSM/DM Docked operations</p> <p>Appendix A</p>	15	
18.2.2	<p><u>Undocking With Soyuz, Apollo DS Passive</u></p>		
1	<p>Perform prep for DM/Soyuz undocking</p> <p>SCS on, 8.4.2</p> <p>Select desired displays, 7.2</p> <p>Select SCS rate damping only, 7.1.4</p> <p>Docking System A</p> <p>cb DS A IND LOGIC MNA - close</p> <p>cb DS A IND PWR AC1 - close</p> <p>cb DS A CONTROL BAT A - close</p> <p>cb DS A MOTORS AC1 (3) - close</p> <p>cb DM POWER (2) - close (verify)</p>	274	

UNDocking WITH SOYUZ, APOLLO DS PASSIVE

18.2.2

NORMAL BACKUP

APOLLO-SOYUZ TEST PROJECT (ASTP)
OPERATIONS HANDBOOK

STA/T STEP	PROCEDURE	PANEL	REMARKS
	<p>XXX X If Soyuz unable to perform undocking, inform Soyuz crew CM will undock. BACKUP PASSIVE (2) - RELEASE (hold ≈ 3 sec)</p>		<p>System A and B simultaneously. Guarded (momentary) - passive hook pulley is driven to the release position (≈2 to 3 seconds) releasing both the passive and active hooks. Power is also provided to the body latch release solenoids releasing the body mounted latches.</p>
	<p>GUIDE RING CAPTURE lt - out PASSIVE lt - out STRUCT RING CONTACT lt - out Verify undocking & inform Soyuz crew</p>		<p>Refer to CM PASSIVE/VEHICLE SEP (BACKUP RELEASE) status lts, Fig 18-1.</p>
	<p>BACKUP PASSIVE (2) - RESET then ctr (off) PASSIVE lt - on</p>	<p>XXX X</p>	<p>Guarded. Passive lt may flicker due to delay in relay lockup. System A and B simultaneously (≈2 to 3 seconds). Resets passive hooks and returns docking system to passive mode. The body mounted latches (3) return to lock position by spring actuation.</p>
3	<p>Post Final Undocking Pnl Config Docking System A cb DS A IND LOGIC MNA - open cb DS A IND PWR AC1 - open cb DS A CONTROL BAT A - open cb MOTORS AC1 (3) - open</p>	<p>STRUCT RING CONTACT lt - out GUIDE RING CAPTURE lt - out</p>	<p>Docking system (DS) post undocking panel configuration defines those circuit breakers requiring operation to deactivate the DS independent of mission consideration.</p>
DP		<p>274</p>	

UNDOCKING WITH SOYUZ, APOLLO DS PASSIVE

18.2.2

NORMAL BACKUP

APOLLO-SOYUZ TEST PROJECT (ASTP)
OPERATIONS HANDBOOK

STA/T STEP	PROCEDURE	PANEL	REMARKS
DP	Docking System B cb DS B IND LOGIC MNB - open cb DS B IND PWR AC2 - open cb DS B CONTROL BAT B - open cb DS B MOTORS AC2 (3) - open	274	
CP	Docking System Status lights (all) - out	2	

UNDocking WITH SOYUZ, APOLLO DS PASSIVE

**APOLLO-SOYUZ TEST PROJECT (ASTP)
OPERATIONS HANDBOOK**

STA/T STEP	PROCEDURE	PANEL	REMARKS
18.3	ENVIRONMENTAL CONTROL/LIFE SUPPORT SYSTEM OPERATIONS		
18.3.1	<u>Docking Module Press Integrity Check</u>		
1	CM/DM ΔP ind - ≈150 to 570 mm Hg	Hatch 2	
2	DM Pressurization DM PRESS ISOL vlv - OPEN DM PRESS vlv - INCR (Increase press to 550 mm Hg. Mon CM/DM ΔP ind to ≈292 mm Hg) DM PRESS vlv - OFF DM PRESS Isol vlv - CLOSE Mon CM/DM ΔP ind time 5 min (no detectable decr allowed)	901 Hatch 2 901	Approximately 12 minutes are required to increase DM pressure from zero to 550mm Hg during initial pressurization.
3	CM/DM Press Equalization DM VENT ISOL vlv - OPEN DM VENT vlv - VENT Mon CM/DM ΔP ind to zero DM VENT vlv - CLOSE DM VENT ISOL vlv - CLOSE Retrieve Tool B Engage Tool B in Hatch PRESS EQUAL VALVE - OPEN	900 Hatch 2 900 Hatch 2	About eight minutes are required to decrease pressure from 550 to 250mm Hg. Final equalization of pressure between the CM and DM is accomplished by opening the pressure equalization valve in hatch #2.

18.3.1

DOCKING MODULE PRESS INTEGRITY CHECK

NORMAL BACKUP

APOLLO-SOYUZ TEST PROJECT (ASTP)
OPERATIONS HANDBOOK

STA/T STEP	PROCEDURE	PANEL	REMARKS
18.3.2	<u>DM Pressurization</u>		
1	Unlock Hatch, swing to the open position, 18.6.1	Hatch 2	
2	Position oxygen hoses in DM retention device (snap in place) - AC/DP oxygen hoses		
3	Check PPO ₂ SYS TEST (2) - 1D SYS TEST ind - 1.5 vdc SYS TEST (2) - 1E SYS TEST ind - 1.5 vdc	101	PPO ₂ should read 165mm Hg before DM ingress. Equivalent to 165mm Hg
4	HIGH PRESS RELIEF vlv (2) - AUTO (verify)	821	
5	O ₂ PURGE PRESS RELIEF vlv - CLOSE (verify)	828	
6	LOW PRESS RELIEF vlv - CLOSE (verify)		
7	O ₂ REG A vlv - ON O ₂ REG B vlv - OFF EMER PRESS REG vlv - 1 PRESS TO TEST O ₂ FLOW HI lt - on MASTER ALARM pb/lt - on, push	826 815	

DM PRESSURIZATION

APOLLO-SOYUZ TEST PROJECT (ASTP)
OPERATIONS HANDBOOK

STA/T STEP	PROCEDURE	PANEL	REMARKS
	O ₂ REG B vlv - ON	828	
	O ₂ REG A vlv - OFF	826	
	EMER PRESS REG vlv - 2 PRESS TO TEST	815	
	O ₂ FLOW HI lt - on	828	
	MASTER ALARM pb/lt - on, push	826	
	O ₂ REG A vlv - ON	815	
	EMER PRESS REG - BOTH		
8	cb WALL HTRS (2) - open		
9	Remove CM oxygen hoses from DM & stow in CM		
10	Perform elect DM Config, 18.4.1 & 18.4.2		
11	If docked (CM/SOYUZ), perform struct latch load cell test, 18.4.5 or 18.4.6		
12	Release Hatch, swing to closed position & latch, 18.6.1	Hatch 2	
13	Unlock and close Hatch PRESS EQUAL VALVE (rotate handle cw)		Handle must be in the yellow-band area (indicates a fully closed valve).

DM PRESSURIZATION

18.3.2

NORMAL BACKUP

APOLLO-SOYUZ TEST PROJECT (ASTP)
OPERATIONS HANDBOOK

STA/T STEP	PROCEDURE	PANEL	REMARKS
18	HHAG - Mon to 490 mm Hg	821	Temporarily stow.
19	DM N2 PRESS vlv - OFF	824	
20	DM N2 PRESS ISOL vlv - CLOSE		
21	DM/CM ΔP ind - Mon 5 min for press change	Hatch 2	
<u>18.3.3 DM Depressurization</u>			
	Adjust DM press to assure proper Soyuz atmosphere	824	Prior to depressurization, a Nitrogen adjustment to the total DM pressure is required to assure proper Soyuz atmosphere (340mm Hg).
	DM N2 PRESS ISOL vlv - OPEN		
	DM N2 PRESS vlv - INCR - Increase press as req		
	Mon press increase with HHAG	821	
	DM N2 PRESS vlv - OFF	824	
	Unlatch Hatch & swing to closed position, 18.6.1	Hatch 3	
	Close and lock Hatch PRESS EQUAL Valve		
	PRESS RELIEF VLV REF - VACUUM	824	
	DM/SOYUZ TUN VENT ISOL vlv - OPEN	803	
	DM/SOYUZ TUN VENT vlv - VENT		
	Vent Tunnel #2 to 260 mm Hg - Mon		Venting Tunnel #2 to 260mm Hg assures a positive pressure on Hatch #3 seals to prevent leakage.
	DM/SOYUZ ΔP ind #230 mm Hg	Hatch 3	
	DM/SOYUZ TUN VENT ISOL vlv - CLOSE	803	
	DM/SOYUZ TUN VENT vlv - CLOSE		
	O2 PURGE PRESS RELIEF vlv - AUTO	828	Oxygen is added to insure PP02 does not fall below acceptable limits during the depressurization sequence.
	O2 PURGE vlv - OPEN (ccw) for ≈4.5 min	824	

DM DEPRESSURIZATION

18.3.3

NORMAL BACKUP

APOLLO-SOYUZ TEST PROJECT (ASTP)
OPERATIONS HANDBOOK

STA/T STEP	PROCEDURE	PANEL	REMARKS
	CM Oxygen hoses - Install in DM retention device & snap in place (AC/DP oxygen hoses) EMER PRESS REG vlv - OFF O2 REG (2) - OFF 18.3.4 <u>Tunnel #2 Integrity Check</u>	826 824	CM oxygen hoses are placed in the DM to provide circulation and remove CO2 for 10 to 15 minutes. Return hose is blocked by retention bracket.
SC	OM Pressurize Tunnel #2 to 260 mmHg Mon OM/DM ΔP ind <u>TBD</u> for change in ΔP OM Pressurize Tunnel #2 to 520 mmHg Mon delta-P gage & Soyuz press indicator (5 min) for change in delta-P (<u>TBD</u>) XX X Tunnel 2 leakage rate higher than <u>TBD</u> Number of transfers will be restricted within consumables available. Restrict total time hatches 3 & 4 are open XX X	Hatch 4	OM (orbital module). Tunnel is initially pressurized by the SC (Soyuz crew) to perform Tunnel #2 and Hatch #4 pressure integrity check. Allowable delta-P <u>TBD</u> . Requires coordination with DM.
			DM #2 supply tank may be depleted prior to completing the fourth transfer.

18.3.4 TUNNEL #2 INTEGRITY CHECK



APOLLO-SOYUZ TEST PROJECT (ASTP)
OPERATIONS HANDBOOK

STA/T STEP	PROCEDURE	PANEL	REMARKS
18.4	ELECTRICAL POWER SYSTEM		
18.4.1	<u>DM Ingress Config</u> LIGHTING 1 - OFF (verify) LIGHTING 2 - START (verify) cb CABIN FAN DMA - close (verify) cb INST (2) - close (verify) cb LIGHTING 1 - DMA - open (verify) cb LIGHTING 2 - DMB - close (verify) cb VHF FM XCVR DMA - close (verify) cb WALL HTRS (2) - close (verify)	815	Configure circuit breakers at launch such that DM systems required for rendezvous, status and thermal control are available without entering the DM.
18.4.2	<u>DM Occupied Config & C&WS Operational Check</u> LIGHTING 1 - OFF LIGHTING 2 - ON cb LIGHTING 1 - DMA - close cb CAUT/WARN DMB - close cb DM AUDIO/TV DMB - close cb UTILITY DMA - close cb SOYUZ POWER DMB - close cb DMA/DMB TIE - open (verify) cb WALL HTRS (2) - open (verify) C&WS Operational Check 02 c/w pb (3) - push 02 c/w lt (3) - on 02 FLOW Hi pb & 02 PP A pb - push (simultaneously)		TV may require both LIGHTING switches on. Reset master alarm after closing circuit breakers.

DM OCCUPIED CONFIG & C&WS OPERATIONAL CHECK

18.4.2

NORMAL BACKUP

APOLLO-SOYUZ TEST PROJECT (ASTP)
OPERATIONS HANDBOOK

STA/T STEP	PROCEDURE	PANEL	REMARKS
	MASTER ALARM pb/lt & tone - on MASTER ALARM pb/lt - push MASTER ALARM pb/lt & tone - out		
18.4.3	<u>DM Vacant Config</u>	815	Wall heaters (3) on only when DM unoccupied.
	LIGHTING 1 - START		
	LIGHTING 2 - OFF (verify)		
	cb CAUT/WARN DMB - open		
	cb WALL HTRS (2) - close		
18.4.4	<u>DM Jettison Config</u>	808	
	UTILITY POWER - OFF	818	
	TV CAMERA POWER - OFF	811	
	AUDIO 2 POWER - OFF	815	
	AUDIO 1 POWER - OFF		
	All cbs open on panel 815 except cb LIGHTING 1 - DMA - close		Interface sealing may be performed normally when any six of the eight DM structural latch load cells indicate proper loads (CLOSE range).
	LIGHTING 2 - OFF		
	LIGHTING 1 - START, ON		
18.4.5	<u>Struct Latches Load Cell Test (CM Active)</u>	856	
	DOCK SYS A TEST SEL - STRUCT LATCH 1,3,5,7		
	DS A TEST ind - CLOSE range		
	DOCK SYS B TEST SEL-STRUCT LATCH 2,4,6,8		
	DS B TEST ind - CLOSE range		

STRUCT LATCHES LOAD CELL TEST (CM ACTIVE)

18.4.5

APOLLO-SOYUZ TEST PROJECT (ASTP)
OPERATIONS HANDBOOK

STA/T STEP	PROCEDURE	PANEL	REMARKS
18.4.6	<u>Struct Latches Load Cell Test</u> (CM Passive)	856	Interface sealing may be performed normally when any six of the eight structural latch load cells indicate proper loads (PASSIVE range).
	DOCK SYS A TEST SEL - STRUCT LATCH		
	1,3,5,7		
	DS A TEST ind - STRUCT LATCH		
	PASSIVE range		
	DOCK SYS B TEST SEL - STRUCT LATCH		
	2,4,6,8		
	DS B TEST ind - STRUCT LATCH		
	PASSIVE range		
18.4.7	<u>Docking System Passive Test</u> (Systems A & B)		
	DOCKING SYS TEST SEL (2) - PASSIVE		
	HOOKS		
	DS TEST ind (2) - CLOSE range		
	DOCKING SYS TEST SEL (2) - BODY		
	LATCHES		
	DS TEST ind (2) - CLOSE range		
	DOCKING SYS TEST SEL (2) - GUIDE		
	RING RETR		
	DS TEST ind (2) - CLOSE range		
	DOCKING SYS TEST SEL (2) - OFF		
			Indicates passive hooks (8) closed.
			Indicates body latches (3) closed.
			Indicates guide ring retracted.
			Erroneous indications on panel 2 displays and PCM are possible if switch is in any passive test position.

18.4.7 DOCKING SYSTEM PASSIVE TEST (SYSTEMS A & B)

NORMAL BACKUP

APOLLO-SOYUZ TEST PROJECT (ASTP)
OPERATIONS HANDBOOK

STA/T STEP	PROCEDURE	PANEL	REMARKS
18.5	TELECOMMUNICATIONS SYSTEM		
18.5.1	<u>DM Speaker Box Operation</u>	818 860	
	AUDIO 2 POWER - ON		
	Speaker Box		
	POWER - ON		
	SIGNAL - on (up)		
	XMIT/I'COM - I'COM		
	VOLUME tv - as req (verify comm)		
	XXXXXXXXXXXXXXXXXXXXXXXXXXXXXXXXXXXXX		
	X No comm		
	Speaker Box		
	POWER - OFF		
	SIGNAL - OFF		
	AUDIO 2 POWER - OFF	818	
	Disconnect Speaker Box from		
	receptacle		
	Connect Speaker Box to receptacle	811	
	AUDIO 1 POWER - ON		
	Speaker Box	860	
	POWER - ON		
	SIGNAL - on (up)		
	XMIT/I'COM - I'COM		
	VOLUME tv - as req (verify comm)		
	Still no comm		
	Speaker Box		
	POWER - OFF		
	SIGNAL - OFF		

DM SPEAKER BOX OPERATION

APOLLO-SOYUZ TEST PROJECT (ASTP)
OPERATIONS HANDBOOK

NORMAL BACKUP

STA/T STEP	PROCEDURE	PANEL	REMARKS
	AUDIO 1 POWER - OFF	811	
	Disconnect Speaker Box 860 from receptacle & stow		For storage, reference NASA document (TBD).
	Unstow Speaker Box 960	818	
	Connect Speaker Box to receptacle	960	
	AUDIO 2 POWER - ON		
	Speaker Box		
	POWER - ON		
	SIGNAL - on (up)		
	XMIT/I'COM - I'COM		
	VOLUME tv - as req (verify comm)		
	Still no comm		
	Speaker Box		
	POWER - OFF	818	
	SIGNAL - OFF	960	
	AUDIO 2 POWER - OFF		
	Disconnect Speaker Box from receptacle and stow		
	Unstow CCU (2) & control Head (2) & connect	Soyuz	
	Unstow light weight head set (2) & connect to CCU control head	TB	TB (transfer bag).
	Connect CCU's to receptacle on audio pnls	818	
	AUDIO 2 POWER - ON (verify comm)	811	
	AUDIO 1 POWER - ON (verify comm)		
	XXXXXXXXXXXXXXXXXXXXXXXXXXXXXXXXXXXX		
	18.5.2 <u>Dm TV Checkout</u>		
	TBD		
	18.5.3 <u>TV Crew Transfers</u>		
	TBD		
	18.5.3		TV CREW TRANSFERS

APOLLO-SOYUZ TEST PROJECT (ASTP)
OPERATIONS HANDBOOK

STA/T STEP	PROCEDURE	PANEL	REMARKS
18.5.4	<u>Soyuz Operations</u>		
1	16MM Data Acquisition Camera Initiation Unstow 16MM DAC & associated cable Attach cable to DAC Remove dust cover from UTILITY POWER receptacle (J1) Attach DAC cable to UTILITY POWER receptacle (J1) UTILITY POWER - ON Config DAC as req	Soyuz TC 808	Transfer container.
2	16MM Data Acquisition Camera Power Down Configure DAC as req UTILITY POWER - OFF Detach DAC cable from UTILITY POWER receptacle (J1) Replace dust cover on UTILITY POWER receptacle (J1) Remove DAC power cable from DAC Stow DAC & cable	Soyuz TC	
3	16MM Data Acquisition Camera Initiation Soyuz Unstow DAC & cable Attach power cable to DAC Attach power cable to UTILITY POWER receptacle cb SOYUZ POWER DMB - close TV/UTILITY POWER - ON Configure DAC as req	Soyuz TC 961 815 961	

SOYUZ OPERATIONS

APOLLO-SOYUZ TEST PROJECT (ASTP)
OPERATIONS HANDBOOK

STA/T STEP	PROCEDURE	PANEL	REMARKS
	Transfer to DM Stow Speaker Box Unstow CCU (2), Control Head (2) & light weight head set (2) from D1 Connect & transfer to Soyuz Connect CCU's to receptacles AUDIO 1 & 2 AUDIO POWER - ON, verify comm XXXXXXXXXXXXXXXXXXXXXXXXXXXXXXXXXXXX X	DM	
6	VHF/FM terminate cb VHF/FM XCVR DMA - open	961	
		815	

SOYUZ OPERATIONS

APOLLO-SOYUZ TEST PROJECT (ASTP)
OPERATIONS HANDBOOK

STA/T STEP	PROCEDURE	PANEL	REMARKS
18.6	MECHANICAL SYSTEMS		
18.6.1	<u>DM Hatch Opening (2 & 3)</u>		
1	Opening DM Hatch from DM exterior Verify AP gage reads zero Retrieve tool B from hatch location Engage Tool B in PRESS EQUAL VALVE PRESS EQUAL VALVE - OPEN CM/DM AP ind (Hatch 2) or SOYUZ/DM AP ind (Hatch 3) reads zero (verify) Engage Tool B in hatch gear box Unlock & release hatch, rotating tool B ccw Swing hatch inward & engage in hold open latch		No opening of DM hatch No. 3 is planned from the Soyuz side, however, a B tool is stowed on hatch No. 2 & 3 and the capability exists. "Hold Open" retention devices are provided in the DM for hatches 2 and 3 which are hinged and open inward along the +Y axis.
2	Opening DM hatch from the DM interior Verify AP gage reads zero PRESSURE EQUAL VALVE - unlock & OPEN DM/CM AP ind (Hatch 2) or DM AP ind (Hatch 3) reads zero (verify) Actv handle rel - Pull & Rotate Actv handle - pull to stop Actv handle sel - U (unlatch) Actv handle - push to stop		Final equalization between the DM and tunnels No. 1 and No. 2 is accomplished by opening the hatch equalization valve.

18.6.1

DM HATCH OPENING (2&3)

NORMAL BACKUP

TEST ITEM	DESCRIPTION	REMARKS

Hatch will not release, one CR
several latches not dismet-
rically opposed have not
unlatched

Remove hinge pin
Separate hatch from DM hatch ring
at hinge point

Remove hatch from DM hatch
ring

Remove hatch from DM hatch
ring

Remove hatch from DM hatch
ring

Remove hatch from DM hatch
ring

Retrieve DM tool kit - obtain tools
W & 4 - snap together

Remove DM hatch ring striker plates
from unlatched latches

Remove two (2) 3/16 inch & one (1)
1/4 inch torq-set screws from
each striker plate

Swing hatch inward & engage in
hold open latch

XXXXXXXXXXXXXXXXXXXXXXXXXXXXXXXXXXXXX

- 3 DM Hatch Closing (2 & 3)
- Closing DM hatch from DM interior
- Disengage hatch from hold open latch
- Swing hatch to closed position

For storage, reference NASA document TED.

APOLLO-SOYUZ TEST PROJECT (ASTP)
OPERATIONS HANDBOOK

STA/T STEP	PROCEDURE	PANEL	REMARKS
	<p>Verify hatch is firmly positioned against sealing surface</p> <p>Actv handle rel - Pull & Rotate</p> <p>Actv handle - Pull to stop</p> <p>Actv handle sel - L (latch)</p> <p>Actv handle - push to stop</p> <p>Verify gear box disconnect socket is opposite L mark on hatch</p> <p>Actv handle sel - stow</p> <p>Actv handle - push to stowed position</p> <p>Push manual gear box lock (chrome tab)</p> <p>Closing DM hatch from the DM exterior</p> <p>Disengage hatch from hold open latch</p> <p>Swing hatch to closed position</p> <p>Engage tool B in gear box socket</p> <p>Pull hatch firmly against sealing surface</p> <p>Rotate tool B cw</p> <p>Remove and stow Tool B</p>		<p>To free active handle for operation. Handle should move $\approx 80^\circ$.</p> <p>Handle should move $\approx 60^\circ$ to engage latches.</p> <p>Actuator handle release automatically locks handle in stowed position.</p> <p>Verifies gear box lock engaged</p> <p>Hatch No. 2 is the only DM hatch which is planned to be closed from the DM exterior. Tool B is, however, provided in Tunnel No. 2 if required.</p>
18.6.2	<p><u>DM/Soyuz Umbilical Installation and Removal</u></p>	Tunnel #2	
	<p>1 Umbilical Installation</p> <p>Open Umbilical Cover</p> <p>Squeeze latch to release</p> <p>Secure open with velcro</p>		

18.6.2

DM/SOYUZ UMBILICAL INSTALLATION AND REMOVAL

NOCTAL BACKUP

APOLLO-SOYUZ TEST PROJECT (ASTP)
OPERATIONS HANDBOOK

STA/T STEP	PROCEDURE	PANEL	REMARKS
	<p>Disconnect Umbilical Connector P1 from storage receptacle - pull to remove</p> <p>Remove dust cap from Soyuz receptacle J1 - grip cap collar and pull</p> <p>Install dust caps on DM P1 storage receptacle - align, depress cap body, & push to install</p> <p>Attach connector P1 to receptacle J1, align, & push to connect</p> <p>Install umbilicals P2 and P3 following the preceding steps</p> <p>Release Umbilical Cover, close, & latch</p>		<p>Grip connector ears or lanyard and pull.</p> <p>Self-locking.</p>
2	<p>Umbilical Removal</p> <p>Open Umbilical Cover, squeeze latch to release, secure open with velcro</p> <p>Disconnect Umbilical Connector P1 from Soyuz receptacle J1 - pull to remove</p> <p>Remove dust cap from DM P1 storage receptacle - grip cap collar & pull</p> <p>Install dust cap on Soyuz receptacle J1, align, & press cap body, & push to install</p> <p>Attach connector P1 to DM P1 storage receptacle, align, and push to connect</p>	Tunnel #2	<p>Grip connector ears or lanyard and pull.</p> <p>Self-locking.</p>

DM/SOYUZ UMBILICAL INSTALLATION AND REMOVAL

APOLLO-SOYUZ TEST PROJECT (ASTP)
OPERATIONS HANDBOOK

REMARKS	PANEL
	<p data-bbox="301 1907 331 2070">STA/T STP2</p> <p data-bbox="301 1524 331 1671">PROCEDURE</p> <p data-bbox="384 1395 513 1889">Remove umbilicals P2 and P3 following the preceding steps Release Umbilical Cover, close, & latch</p>

DM/SOYUZ UMBILICAL INSTALLATION AND REMOVAL

18.6.2

19.0 ABORT PROCEDURES

During the ascent phase, an abort can be accomplished in an LES, RCS, or SPS mode. An abort in the LES mode is accomplished by utilizing the launch escape system, which has solid propellant motors mounted on a tower above the command module. During a normal mission, the launch escape tower is jettisoned approximately 17 seconds after second-stage booster ignition. After the launch escape tower is jettisoned, an abort can be accomplished in the RCS mode, or SPS mode, by first utilizing the service module RCS jets to translate away from the LV. The SPS engine will be utilized, on a MODE III and MODE IV abort, to place the CSM in the desired trajectory for landing (MODE III) or earth orbit (MODE IV).

19.1 LES ABORT MODES

An abort may be initiated automatically by the emergency detection system (EDS) when two LV engines fail, LV excessive rates are detected, breakup between IU and CSM, or manually when the commander's translation control is rotated to the full CCW position. Upon receipt of an abort signal, regardless of its source, the booster is cut off (if after T +40 seconds), the CM is separated from the SM, and simultaneous ignition of the launch escape and pitch control motors takes place. Firing of the pitch control motor is inhibited 61 seconds after lift-off. Cutoff of the booster engines is inhibited for the first 40 seconds after lift-off by circuitry in IU because of range safety restrictions. The LES motors provide thrust to propel the command module away from the launch pad or trajectory of the launch vehicle.

Certain events that occur during an abort are controlled automatically by controllers in the sequential events control system (SECS). The earth landing sequence controller (ELSC) contains high-altitude and low-altitude baroswitches. The opening of these baroswitches inhibit ELS operations and the closing initiates the operations. The high-altitude baroswitch controls automatic LES tower jettison, apex cover jettison, and drogue parachute mortar fire. The high-altitude baroswitch is designed to open at 38,500 feet and close at 24,000 feet. Because of venting lag, the high-altitude baroswitch will not open until 40,500 feet during ascent. An abort initiated under 30,000 feet (low part of abort mode 1-B), the 24K feet baroswitch will remain closed and allow automatic LES tower jettison, apex cover jettison, and drogue parachute and main parachute

19.1

LES ABORT MODES

ABORT

APOLLO-SOYUZ TEST PROJECT (ASTP)
OPERATIONS HANDBOOK

deployment on a timed sequence controlled by time-delay relays. On an abort initiated between 30,000 feet and 2 minutes 46 seconds, automatic LES tower jettison, apex cover jettison, and drogue parachute deployment are delayed until the command module descends to the closing altitude of the high-altitude baroswitch (24,900 to 21,500 feet).

The low-altitude (10K') baroswitch is closed at 10,000 feet, open at 15,000 feet. Opening of the low-altitude baroswitch will delay automatic deployment of the pilot-main parachutes until the command module descends to the closing altitude (10,250 to 9100 feet).

The LES abort is divided into three different modes as follows:

- Mode 1-A (launch pad to 61 seconds)
- Mode 1-B (61 seconds to 1 minute 48 seconds)
- Mode 1-C (1 minute 48 seconds to LES tower jettison)

During a Mode 1-A abort, CM RCS oxidizer automatically dumps overboard through an outlet in the aft heat shield. CM RCS fuel automatically dumps overboard through a similar outlet in the aft heat shield 5 seconds after oxidizer dump started, and requires about 11 seconds for depletion. CM RCS helium automatically begins purging the system 13 seconds after fuel dump started.

After the main parachutes disreef and a land impact is anticipated, during a Mode 1-B abort, manual initiation fires ten CM RCS jets to expend all propellant, followed by manually initiated helium expenditure through the jets to purge the system.

The auto abort capability due to two engines out or LV rates is switched off prior to SLR staging, and the crew must be ready to manually initiate an abort if these conditions arise. During a Mode 1-C abort (over 100K'), it is possible to jettison the LET and accomplish a normal entry provided certain conditions prevail. There must be sufficient TFF (100 sec) to perform the entry maneuver, a reliable attitude reference, and launch escape vehicle (LEV) rates must be within tolerance. In any of these conditions are not met, the LET must be retained to insure capture of the crew with the heat shield oriented forward.

LES ABORT MODES

APOLLO-SOYUZ TEST PROJECT (ASTP)
OPERATIONS HANDBOOK

The altitude and velocity of the LEV is such that a possibility exists that it could enter the atmosphere canard and escape tower forward. The LEV would remain in this condition until descending below 100,000 feet and Mach 3.8. At this time a fast turnaround would occur which would be detrimental to crew safety. The crew will prevent canard forward capture by manual intervention shortly after abort initiation. A positive pitch rate of over 5° per second will be commanded and maintained until the canard starts trailing the CM upon descending to an altitude under 100,000 feet. Escape tower jettison and ELS activation will automatically occur at approximately 24,000 ft provided that the ELS AUTO sw is in the AUTO position.

The ELS decelerates the CM to a safe touchdown speed. Crew couch attenuators reduce the touchdown impact and start operating at approximately 15 G when they are unlocked. If they are not unlocked, a pin will shear in the lock at approximately 21 G and allow them to operate.

19.1

LES ABORT MODES

ABORT

APOLLO-SOYUZ TEST PROJECT (ASTP)
OPERATIONS HANDBOOK

STA/T STEP	PROCEDURE	PANEL	REMARKS
15.1.1	Mode LA LES Abort (00:00 - 01:01)		
AC I	Abort initiation auto or manual CHC - CCW XXXXXXXXXXXXXXXXXXXX X	X X X X	If manual backup required for any auto event after abort initiation it must be performed after LE motor burnout (abort T +00:05) because of high G environment during LE motor burn.
CP	X CM/SM SEP (both) - on (up) XXXXXXXXXXXXXXXXXXXX X BECO (auto after T +00:40) Evt. Tmr rset and counting up (auto) CM/SM deadface (auto) SM C/W lts - on MASTER ALARM pb/lt - on CM RCS press (auto)	X X X X X X X X X X X X X X X X X X X X	Guarded. On position is momentary. If abort is initiated with CM/SM SEP switches, subsequent events may require manual initiation and must be performed after LE motor burnout.
00:00			
AC			Because of switching transients, AC BUS 1 and 2 C/W lights will go on and MN BUS A and MY BUS B UV lights might go on if abort is initiated prior to T -01:00.

MODE LA LES ABORT (00:00 - 01:01)

APOLLO-SOYUZ TEST PROJECT (ASTP)
OPERATIONS HANDBOOK

STA/T STEP	PROCEDURE	PANEL	REMARKS
AC	<p>RCS cont trnfr (auto)</p> <p>Entry bats to main buses (auto if abort initiated prior to T -01:00)</p> <p>CM RCS oxidizer dump (auto)</p> <p>CM RCS isol vlvs close (auto)</p> <p>CM/SM sep (auto)</p> <p>LE & PC motors fire (auto)</p> <p>CM/SM sep pyro deadface (auto)</p> <p>CM RCS fuel dump (auto)</p> <p>XXXXXXXXXXXXXXXXXXXX</p> <p>X</p> <p>X If abort initiated with CM/SM SEP (both) or if backup req for any auto evnt</p> <p>X</p>	<p>X</p> <p>X</p> <p>X</p> <p>X</p> <p>X</p> <p>X</p> <p>X</p> <p>X</p> <p>X</p> <p>X</p> <p>X</p> <p>X</p> <p>X</p> <p>X</p> <p>X</p> <p>X</p> <p>X</p> <p>X</p> <p>X</p> <p>X</p> <p>X</p>	<p>MN BUS TIE switches are set to AUTO by T -1 hour and then to ON at T -01:15. DC main buses must be energized to provide power for RCS transfer, propellant dump, and purge.</p> <p>CM/SM umbilical and tension ties severed.</p>
00:00.1			
00:01.8			
00:05			
AC			

MODE 1A LES ABORT (00:00 - 01:01)

19.1.1.1



APOLLO-SOYUZ TEST PROJECT (ASTP)
OPERATIONS HANDBOOK

STA/T STEP	PROCEDURE	PANEL	REMARKS
AC 00:14	ELS logic arm (auto)	X	
	ELS AUTO - AUTO	X X X X X X X X X X X X	
4	ELS LOGIC - on (up)	X	Guarded.
	LES TWR jett (auto)	X	
CP	a. Docking ring sep	X	
	b. TWR attach nuts detonate	X TWR JETT (both) - on (up)	Guarded. On position is momentary.
	c. SCS RCS disable	X RCS CMD - OFF	OFF position is momentary.
	d. TWR jett motor fire	X X X X X	
AC 00:14.4	Apex cover jett (auto)	X APEX COVER JETT pb - push	Guarded.
00:16	Drogue chutes deploy (auto)	X DROG DPLY pb - push (2 sec after apex cover jett)	Guarded.
	<u>WARNING</u>	X X X X X X X X X X	
	Below alidade marker on altimeter, MN DPLY pb - push		Alidade set for 3800 feet true altitude prior to launch.

MODE LA LES ABORT (00:00 - 01:01)



19.1.1

APOLLO-SOYUZ TEST PROJECT (ASTP)
OPERATIONS HANDBOOK

STA/T STEP	PROCEDURE	PANEL	REMARKS
AC 18	ELS LOGIC - on (up) (verify)		
OP 19	CM ACS PRELIM (both) - OFF		OFF position is momentary.
	CM RCS PRELIM (1) (both) - OFF		Barber pole indicates at least one valve closed in each system.
AC 20	DIRECT O2 VLV - OPEN (CCW)		
DP 21	MN BUS TIE (2) - OFF		Removes battery power from dc main buses.
	CAUTION		
	MN BUS TIE switches must be left OFF to ensure that bats A, B & C are used to pwr postlanding sys only, & to prevent bat shorting caused by water entering CM feedthru connectors.		
22	cb BAT RLY BUS (2) - open		
23	Postlanding check, sec 16		

MODE LA LES ABORT (00:00 - 01:01)

APOLLO-SOYUZ TEST PROJECT (ASTP)
OPERATIONS HANDBOOK

STA/T STEP	PROCEDURE	PANEL	REMARKS
19.1.1.2	Mode 1B LES Abort (01:01 - 01:48)		
AC 1	Abort initiation auto or manual THC - CCW XXXXXXXXXXXXXXXXXXXXXXXXXXXX X X CM/SM SEP (both) - on X (up) X XXXXXXXXXXXXXXXXXXXXXXXXXXXX X X BECO (auto) X Request Ground command BECO 00:00 Evt Tmr rset & counting up (auto) X X CM/SM deadface (auto) X X SM C/W lts - on X X MASTER ALARM pb/lit - on AC CM RCS press (auto) RCS cont trnfr (auto) 00:00.1 CM/SM sep (auto) X		<p>If manual backup required for any auto event after abort initiation, it must be performed after LE motor burnout (abort T +00:05) because of high G environment during LE motor burn.</p> <p>Guarded. On position is momentary. If abort initiated with CM/SM SEP switches, subsequent events may require manual initiation and must be performed after LE motor burnout.</p> <p>CM/SM umbilical and tension ties severed.</p>

MODE 1B LES ABORT (00:01 - 01:48)

19.1.2



APOLLO-SOYUZ TEST PROJECT (ASTP)
OPERATIONS HANDBOOK

STA/T STEP	PROCEDURE	PANEL	REMARKS
AC	LE motor fire (auto)	X >	
00:01	SUS/RCS enbl (auto)	X >	
00:01.8	CM/SM sep proto headface (auto)	X X X X X X X	
	XXXXXXXXXXXXXXXXXXXX		
00:05	X If abort initiated with CM/SM SEP (both) or if backup req for any auto evnt		
	EVNT TMR RSET - RSET		RSET position is momentary.
	EVNT TMR START - START		START position is momentary.
CP	CM RCS PRESS - on (up)		Guarded. On position is momentary.
	RCS TRNFR - CM		CM position is momentary.
AC	LES MOT FIRE pb - push		Guarded.
CP	RCS CMD - ON		ON position is momentary.
	XXXXXXXXXXXXXXXXXXXXXXXX		
AC	Canard deploy (auto)	X X X	
00:11	Canard deploy (auto)	X CHRD DPLY pb - push (hold for 3 sec)	
CP	C/W GSM - CM	X X X	Extinguishes all SM C/W lights and allows CM RCS lights to function.

MODE 1B LES ABORT (00:01 - 01:48)

APOLLO-SOYUZ TEST PROJECT (ASTP)
OPERATIONS HANDBOOK

STA/T STEP	PROCEDURE	PANEL	REMARKS
DP 3	MASTER ALARM pb/lt - push	X X X X	
AC 00:14	ELS logic arm (auto)	X ELS LOGIC - on (up)	Guarded.
	ELS AUTO - AUTO	X	
24K'	LES TWR jett (auto)	X	
CP	a. Docking ring sep	X	
	b. TWR attach nuts detonate	X TWR JETT X (both) - on (up)	Guarded. On position is momentary.
	c. SCS RCS disable	X RCS CMD - OFF	OFF position is momentary.
	d. TWR jett mot fire	X	
AC	Apex cover jett (auto)	X APEX COVER JETT X pb - push	Guarded.
	Drogue chutes deploy (auto)	X DROG DPLY pb - push X (2 sec after X apex cover jett)	Guarded.
23.5K'	4 Mon CAB PRESS ind - starts incr	X If no incr by 17K' X rh CAB PRESS X RELF vlv - X DUMP (safety X latch off)	No increase indicates cabin pressure relief valve failure.

MODE 1B LES ABORT (00:01 - 01:48)

19.1.2

ABORT

APOLLO-SOYUZ TEST PROJECT (ASTP)
OPERATIONS HANDBOOK

STA/T STEP	PROCEDURE	PANEL	REMARKS
CP	<p>X If still no X incr X CAB PRESS DUMP X vlv - open X (CCH) X</p>		
ACP	<p>CAB PRESS ind - 10 psia Main chutes & VRF recovery ant deploy (auto)</p>	2	<p>Indication of main chute deploy altitude. Auto deployment occurs between 10,950 feet and 9,100 feet. Parachutes disreef in ~15 seconds.</p>
AC	<p>5 MN DPLY pb - push 6 rn CAB PRESS RELF vlv - DUMP (safety latch off)</p>		<p>Guarded.</p>
	<p>XXXXXXXXXXXXXXXXXXXXXXXXXXXX X X If CM PRPLNT DUMP req X X X X</p>		
	<p><u>CAUTION</u> CM PRPLNT DUMP should be initiated immedi- ately after main chute disreefing. If main or pyro bus lost, use RHCs for burn, not CM PRPLNT DUMP switch.</p>		

MODE 1B LES ABOUT (00:01 - 01:48)

APOLLO-SOYUZ TEST PROJECT (ASTP)
OPERATIONS HANDBOOK

STA/T STEP	PROCEDURE	PANEL	REMARKS
CP	X CAB PRESS RELF vlv If CAB PRESS DUMP X (2) - CLOSE (safety vlv used to X latch off) equalize ΔP, CAB X X PRESS DUMP vlv - X X close (CW) X CM PRPLNT DUMP - on X (up) (dump burn is X audible) X RCS IND sel - CM 1 RCS IND sel - CM 2 X CM RCS He PRESS CM RCS He PRESS X ind - decr ind - decr X If no decr or X RCS jets not X firing X RHC (both) - X Fire all RCS X jets (except X plus pitch) X until X prplnts X are depleted X XXXXXXXXXXXXXXXXXXXXXXXXXXXX		Guarded.
AC, CP	DP 7 Set up entry comm X VHF ANT - RECY X VHF AM A - SIMPLEX X VHF BCN - ON X Xmit voice X (VHF AM) reporting X Position X		One RHC positioned to command plus yaw and roll (excluding plus pitch) and other RHC positioned to command minus yaw, pitch and roll. If VHF AM B - SIMPLEX or VHF AM A - DUPLEX required, turn off beacon during period of communication. Continue voice transmission until touchdown.

MODE 1B LES ABORT (00:01 - 01:48)

19.1.2

ABORT

APOLLO-SOYUZ TEST PROJECT (ASTP)
OPERATIONS HANDBOOK

STA/T STEP	PROCEDURE	PANEL	REMARKS
DP 10	cb FLT/PL BUS BAT A, B & X C (3) - close		Connects battery bus A, B, and battery C to flight and postlanding bus.
11	cb FLT/PL BUS MVA - open		
12	cb FLT/PL BUS MVB - open		
AC 13	cb SPS PITCH (2) - open		
14	cb SPS YAW (2) - open		
	XXXXXXXXXXXXXXXXXXXXXXXXXXXX		
	X		
	X If PRPLNT DUMP/BURN		
	X performed		
3K'	X rh CAB PRESS RELF vlv -		
	X DUMP (safety latch		
	X off)		
	X		
	XXXXXXXXXXXXXXXXXXXXXXXXXXXX		
AC 15	FLOOD FIXED - POST LDG		Provides power from flight and postlanding bus to one floodlight in LH couch area and one floodlight in center couch area.
16	FLOOD DIM - 1 or 2		Position 1 provides power to two secondary floodlights, and position 2 provides power to two primary floodlights when FLOOD FIXED switch in POST LDG position after dc main buses deactivated.

MODE 1B LES ABORT (00:01 - 01:48)

APOLLO-SOYUZ TEST PROJECT (ASTP)
OPERATIONS HANDBOOK

STA/T STEP	PROCEDURE	PANEL	REMARKS
800' 17	CAB PRESS RELF vlv (2) - CLOSE (safety latch off)	- X If CAB PRESS DUMP vlv used to equalize AP, CAB PRESS DUMP vlv - close (CW)	Valves must be closed prior to touchdown to prevent water from entering CM.
CP		X	Guarded.
AC 18	ELS LOGIC - on (up) (verify)	X	
CP 19	CM RCS PRPLNT (both) - OFF	X	OFF position is momentary.
	CM RCS PRPLNT tb (both) - bp	X	Barber pole indicates at least one valve closed in each system.
AC 20	DIRECT 02 vlv - OPEN (CCW)	X	
DP 21	MN BUS TIE (2) - OFF	X	Removes battery power from dc main buses.
	<u>CAUTION</u>	X	
	MN BUS TIE switches must be left OFF to ensure that bats A, B and C are used to pwr postlanding sys only, & to prevent bat shorting caused by water entering CM feed-thru connectors.	X	
		X	
		X	
		X	
		X	
		X	
22	cb BAT RLY BUS (2) - open	X	
23	Postlanding check, sec 16	X	

MODE 1B LES ABORT (00:01 - 01:48)

19.1.2



APOLLO-SOYUZ TEST PROJECT (ASTP)
OPERATIONS HANDBOOK

STA/T STEP	PROCEDURE	PANEL	REMARKS
19.1.1.3	Mode 1C LES Abort (01:48 - 02:51)		
AC 1	Abort initiation (auto or manual) THC - CCW XXXXXXXXXXXXXXXXXXXXXXXXXX X X CM/SM SEP (both) - on X (up) X XXXXXXXXXXXXXXXXXXXXXXXXXX X X Request ground command BECO X Evt Tmr rset & counting up (auto) X CM/SM deadface (auto) X SM C/W lts - on X MASTER ALARM pb/lt - on X CM RCS press (auto) X RCS cont trnfr (auto) X 00:00.1 CM/SM sep (auto) X		<p>If manual backup required for any auto event after abort initiation it must be performed after LE motor burnout (abort T +00:05) because of high G environment during LE motor burn.</p> <p>Guarded. On position is momentary. If abort initiated with CM/SM SEP switches, subsequent events may require manual initiation and must be performed after LE motor burnout.</p> <p>CM/SM umbilical and tension ties severed.</p>

MODE 1C LES ABORT (01:48 - 02:51)

APOLLO-SOYUZ TEST PROJECT (ASTP)
OPERATIONS HANDBOOK

STA/T STEP	PROCEDURE	PANEL	REMARKS
AC	LE motor fire (auto) X >		
00:01	SCS/RCS enable (auto) X >		
00:01.8	CM/SM sep pyro X X		
	deadface (auto) X X		
00:05	XXXXXXXXXXXXXXXXXXXXXXXXX		
	X If abort initiated with		
	X CM/SM SEP (both) or if		
	X backup req for any		
	X auto evnt		
	X		
00:00	EVNT TMR RSET - RSET		RSET position is momentary.
	EVNT TMR START - START		START position is momentary.
CP	CM RCS PRESS - on (up)		Guarded. On position is momentary.
	RCS TRNFR - CM		CM position is momentary.
AC	LES MOT FIRE pb - push		Guarded.
CP	RCS CMD - ON		ON position is momentary.
	XXXXXXXXXXXXXXXXXXXXXXXXX		
	X		
AC			
00:11	Canard deploy (auto) X		
	X CNRD DPLY pb - push		
CP	2 C/W CSM - CM X X		
	X		

MODE 1C LES ABORT (01:48 - 02:51)

19.1.3



APOLLO-SOYUZ TEST PROJECT (ASTP)
OPERATIONS HANDBOOK

STA/T STEP	PROCEDURE	PANEL	REMARKS
AC 8	BMAG MODE (3) - ATT 1/ RATE 2	X	
		X	
		X	
9	ATT DBD - MAX	X	
		X	
10	Set up for CM RCS sys 1	X	
	AUTO RCS CM 1	X	
	(6) - MNA/MNB	X	
		X	
	AUTO RCS CM 2	X	
	(6) - OFF	X	
		X	
11	BMAG MODE (3) - RATE 2	X	
		X	
12	EMS FUNC - ENTRY	X	
		X	
13	EMS MODE - NORM	X	
		X	
14	When .05 G lt - on	X	
	.05 G sw - on (up)	X	
		X	
15	EMS ROLL - on (up)	X	
		X	
16	Maintain full lift	X	
		X	
50K' 17	Go to Earth Landing, sec 15	X	
		X	

Prevents FDAI roll bug jump.

MODE 1C LES ABORT (01:48 - 02:51)

19.1.3



APOLLO-SOYUZ TEST PROJECT (ASTP)
OPERATIONS HANDBOOK

STA/T STEP	PROCEDURE	PANEL	REMARKS
CP	Accept PRO X Reject Key V25E X Load X desired X GET Lat X Long X d. FL V06 N43 Lat (+North) X XXX.XX DEG X Long (+East) X XXX.XX DEG X Alt XXXX.X NM X		State vector integrated to desired time. Altitude is above launch pad radius. At this point, alt/10, VI, and gamma is available by keying N73E. Connects battery bus A, B, and battery C to flight and postlanding bus.
DP	25 cb FLT/PL BUS BAT A, B & C (3) - close X 26 cb FLT/PL BUS MNA - open X 27 cb FLT/PL BUS MNB - open X 28 cb SPS PITCH (2) - open X 29 cb SPS YAW (2) - open X 30 FLOOD FIXED - POST LEG X		Provides power from flight and postlanding bus to one floodlight in LH couch area and one floodlight in center couch area.

MODE 1C LES ABORT (01:48 - 02:51)

19.1.3



APOLLO-SOYUZ TEST PROJECT (ASTP)
OPERATIONS HANDBOOK

STA/T STEP	PROCEDURE	PANEL	REMARKS
AC 31	FLOOD DIM - 1 or 2		Position 1 provides power to two secondary floodlights and position 2 provides power to two primary floodlights when FLOOD FIXED switch is in POST LDG position and dc main buses deactivated.
800' 32	CAB PRESS RELF vlv (2) - CLOSE (safety latch off)	- X If CAB PRESS DUMP vlv used to equalize ΔP, CAB PRESS DUMP vlv - close (CW)	Valves must be closed prior to touchdown to prevent water from entering CM.
CP			
AC 33	ELS LOGIC - on (up) (verify)		Guarded.
34	CM RCS PRPLMT (both) - OFF		OFF position is momentary.
	CM RCS PRPLMT tb (both) - bp		Barber pole indicates at least one valve closed in each system.
35	DIRECT 02 vlv - OPEN (CCW)		
36	MN BUS TIE (2) - OFF		Removes battery power from dc main buses.
	<u>CAUTION</u>		
	MN BUS TIE switches must be left OFF to ensure that bats A, B & C are used to power postlanding systems only, & to prevent bat postlanding caused by water entering CM thru connectors.		

MODE 1C LES ABORT (01:48 - 02:51)

APOLLO-SOYUZ TEST PROJECT (ASTP)
OPERATIONS HANDBOOK

STA/T STEP	PROCEDURE	PANEL	REMARKS
DP 37	cb BAT RLY BUS (2) - open	X X X X X	
38	Postlanding check, sec 16	X	

19.1.3

MODE 1C LES ABORT (01:48 - 02:51)

ABORT

19.2 RCS/SPS ABORT MODES II, III, IV

Mode II, III, and IV aborts are manually initiated and utilize the SM RCS or SM RCS and SPS engines to provide CSM/SIVB separation and translation. After separation and CSM stabilization, the abort possibilities separate into three categories.

- CSM/SM separation and coast-to-landing site (MODE II).
- Shaped trajectory abort utilizing an SPS variable ΔV maneuver to correct the trajectory for the desired landing site in the Atlantic Recovery Area (MODE IIIA & IIIB).
- Abort-to-earth-orbit utilizing the SPS engine to attain earth orbital altitude and velocity (MODE IV).

RCS/SPS ABORT MODES II, III, IV

**APOLLO-SOYUZ TEST PROJECT (ASTP)
OPERATIONS HANDBOOK**

STA/T STEP	PROCEDURE	PANEL	REMARKS
19.2.1	<u>Mode II RCS Abort (02:51 to Mode IIIA or IV)</u>		
AC 1	THC - CCW (4.0 sec min)	X	Direct ullage commanded when THC placed CCW. THC must be left in CCW detent for 4.0 seconds to allow 3.0-second timer (adapter separation) and 0.8-second timer (RCS enable) to operate.
00:00	Evtm Tmr rset & counting up (auto)	X EVNT TMR RSET - X RSET X EVNT TMR START - X START	RSET position is momentary. START position is momentary.
	BECO (auto)	X Request ground	
	LV ENG 1 - on	X command BECO	
	Direct ullage started (auto)	X DIR ULL pb - push X X X	If auto direct ullage present (THC-CCW), DIR ULL pb must not be actuated (avoids tying together main bus A & B at DIR ULL pb).
00:03	Adapter sep (auto)	X CSM/LV SEP pb -	Guarded.
CP	LV ENG 1t (1) - out	X push	
00:03.08	RCS/SCS enbl (auto)	X RCS CMD - ON	ON position is momentary. Calls R30 for meaningful display of N50.
	Key VS2E	X	
	FL V16 N44	X	
	Ha XXXX.X NM	X	Apogee altitude.
	Hp XXXX.X NM	X	Perigee altitude.
	TFF XXXXX MIN-SEC	X	Time of free fall to 49.4 NM (300,000 ft).
AC 2	THC - ARMED, ctr, damp rates, then +X Check SM RCS tbs	X DIR ULL pb - push X X X	Automatic direct ullage terminated when THC returned to center.

19.2.1 MODE II RCS ABORT (02:51 TO MODE IIIA OR IV)

ABORT

APOLLO-SOYUZ TEST PROJECT (ASTP)
OPERATIONS HANDBOOK

STA/T STEP	PROCEDURE	PANEL	REMARKS
CP	3 Key N50E Splash error	X X	Negative for undershoot, positive for overshoot. If TFF <100 seconds, maneuver-to-entry attitude must be initiated immediately and separation performed at entry attitude.
	XXX.X NM Hp XXX.X NM	X X	
	TFF XXBYX MIN-SEC	X	
		X	
		X	
	If TFF <100 sec, go to 9	X	
AC		X	
00:24	4 Terminate +X trans	X	
		X	
		X	
	5 If TFF >2 min Yaw 45° (out of plane)	X X X	If TFF <100 seconds, maneuver-to-entry attitude must be initiated immediately and separation performed at entry attitude.
	Start R&P mvvr to entry att P 0°, P 130°	X X	
		X	
		X	
		X	
		X	
		X	
		X	
		X	
		X	
	6 BWAG MODE (3) - ATT 1/ RATE 2	X X	Guarded. On position is momentary. Jettisons docking ring.
		X	
		X	
	7 cb DOCK RING SEP (2) - close (pull lanyard)	X X	
		X	
CP	DOCK RING SEP (both) - on (up)	X X X	

MODE II RCS ABOUT (02:51 TO MODE IIIA OR IV)

APOLLO-SOYUZ TEST PROJECT (ASTP)
OPERATIONS HANDBOOK

STA/T STEP	PROCEDURE	PANEL	REMARKS
CP 8	CM/SM SEP (both) - on (up)	X	Guarded. On position is momentary. CM/SM umbilical and tension ties severed.
	CM/SM deadface (auto)	X	
	SM C/W lts - on	X	
DP	MASTER ALARM pb/lts - on	X	
AC	CM RCS press (auto)	X	
	RCS cont trnfr - (auto)	X	
	CM/SM sep (auto)	X	
	CM/SM sep pyro deadface (auto)	X	
	C/W CSM - CM	X	
DP	MASTER ALARM pb/lt - push	X	
AC 9	Start yaw mnvr to entry att Y 0°	X	
	10 ATT DBD - MAX	X	
	11 Note TFF	X	
01:40	12 Mnvr to entry att R 0°, P 140°, Y 0°	X	
		X	Maneuver-to-entry attitude must be completed prior to TFF = 0 seconds.
		X	BEF, heads down, full lift.

MODE II RCS ABORT (02:51 TO MODE IIIA OR IV)

19.2.1



APOLLO-SOYUZ TEST PROJECT (ASTP)
OPERATIONS HANDBOOK

STA/T STEP	PROCEDURE	PANEL	REMARKS
AC 13	Set up for CM RCS sys 1 AUTO RCS CM 1 (6) - MVA or MVB AUTO RCS CM 2 (6) - OFF	X X	Prevents roll bug jump when .05 G switch set to on.
AC 14	BMAG MODE (3) - RATE 2	X	
15	EMS FUNC - ENTRY	X	
16	EMS MODE - NORM	X	
17	When .05 G lt - on, .05 G sw - on (up)	X X	
18	EMS ROLL - on (up)	X	
19	Maintain full lift	X	
20	Go to Earth Landing, sec 15	X X	
		X	

MODE II RCS ABORT (02:51 TO MODE IIIA OR IV)

APOLLO-SOYUZ TEST PROJECT (ASTP)
OPERATIONS HANDBOOK

STA/T STEP	PROCEDURE	PANEL	REMARKS
19.2.2	Mode IIIA SPS Abort (09:28 to Mode IIIB)		
AC 1	THC - CCW (4.0 sec min)	X X X X X	SPS posigrade burn to downrange recovery area. Direct ullage commanded when THC placed CCW. THC must be left in CCW detent for 4.0 seconds to allow 3.0-second timer (adapter separation) and 0.8-second timer (RCS enable) to operate.
00:00	Evtm Tmr rset & counting up (auto)	X EVMT TMR RSET - X RSET	RSET position is momentary.
	BECO (auto)	X EVMT TMR START - X START X Request ground X command SIVB X BECO	START position is momentary.
	LV ENG 1 lt - on Dir ullage started (auto)	X X DIR ULL pb - push X X X	If auto direct ullage present (THC-CCW), DIR ULL pb must not be activated (avoids tying together main bus A & B at DIR ULL pb).
00:03	Adapter sep (auto) LV ENG 1 lt - out	X CSM/LV SEP pb - X push	Guarded.
CP 00:03.8	RCS/SCS enbl (auto) If not previously selected in boost Key V82E N62E VI XXXX. FPS Hdot XXXX. FPS Hpad XXXX.X NM	X RCS CMD - ON X X X X X X X	ON position is momentary.

19.2.2

MODE IIIA SPS ABORT (09:28 TO MODE IIIB)

ABORT

APOLLO-SOYUZ TEST PROJECT (ASTP)
OPERATIONS HANDBOOK

STA/T STEP	PROCEDURE	PANEL	REMARKS
AC	AUTO RCS SEL CM 2 (6) - OFF BMAG MODE (3) - RATE 2		Prevents roll bug jump when .05 G switch is set to on.
9	EMS MODE - STBY	X	
	EMS FUNC - ENTRY	X	
	EMS MODE - NORM	X	
	Maintain full lift to .05 G	X	
		X	
		X	
		X	
10	When .05 G lt - on, .05 G sw - on (up) EMS ROLL - on (up)	X X X	
11	Fly max lift to 0.2 G then roll left 55 deg (LV South)	X X X X X	
50K'	Go to Earth Landing, sec 15	X X	

MODE IIIA SPS ABORT (09:28 TO MODE IIIB)

ABORT

19-2-3

APOLLO-SOYUZ TEST PROJECT (ASTP)
OPERATIONS HANDBOOK

STA/T STEP	PROCEDURE	PANEL	REMARKS
19.2.3	Mode IIIB SPS Abort (Mode IIIA to Insertion)		
AC 1	THC - CCW (4.0 sec min)	X	SPS retrograde burn to downrange recovery area.
		X	Direct ullage commanded when THC placed CCW. THC must be left in CCW detent for 4.0 seconds to allow 3.0-second timer (adapter separation) and 0.8-second timer (RCS enable) to operate.
		X	
		X	
00:00	Event Tmr rset & counting up (auto)	X EVNT TMR RSET - RSET	RSET position is momentary.
	BECO (auto)	X EVNT TMR START - START Request ground command SIVB BECO	START position is momentary.
	LV ENG 1 lt - on	X	
	Dir ullage started (auto)	X DIR ULL pb - push	If auto direct ullage present (THC-CCW), DIR ULL pb must not be activated (avoids tying together main bus A & B at DIR ULL pb).
00:03	Adapter sep (auto)	X	Guarded.
	LV ENG 1 lt - out	X CSM/LV SEP pb - push	
CP		X	
00:03.8	RCS/SCS enbl (auto)	X RCS CMD - ON	ON position is momentary.
	If not previously selected in boost	X	
	Key V92E	X	Calls R30 for meaningful display of N50.
	FL V16 N44	X	
	Ha XXXX.X NM	X	Apogee altitude.
	Hp XXXX.X NM	X	Perigee altitude.
	TFF XXBXX MIN- SEC	X X	Time of free fall to 49.4 NM (300,000 ft).
		X X	
		X	

MODE IIIB SPS ABORT (MODE IIIA TO INSERTION)

APOLLO-SOYUZ TEST PROJECT (ASTP)
OPERATIONS HANDBOOK

STA/T STEP	PROCEDURE	PANEL	REMARKS
AC 01:50	Ullage THC - +X (IGN + 1 sec) ΔV THRUST A - NORM	X DIR ULL pb - push X X	Guarded.
02:05	SPS THRUST - DIR ON	X No SPS IGN X ΔV THRUST B - NORM X X If still no IGN X THRUST ON pb - push X X	Lever lock.
IGN+1SEC RATE - HI			Bypasses noise problem in SCS gyro assemblies because of thrusting vibration levels and provides backup to auto selection of high rate in pitch and yaw TVC.
	Terminate ullage	X X	
6	VC = desired value (ΔR = -140 NM)	X X	
or	TFF = 1+00	X	
	ΔV THRUST (2) - OFF	X	
	If TFF >2 min Yaw 45° (out of plane) before CM/SM sep	X X X X X X X X X	
	If TFF <2 min, start mnr to entry att R 0°, P 120°, Y 0°	X X X X X X	
	cb MNA & MNB BAT C (2) - close	X X X X	Maneuver to entry attitude must be completed prior to TFF = 0 seconds.

MODE I IIB SPS ABORT (MODE I IIA TO INSERTION)

APOLLO-SOYUZ TEST PROJECT (ASTP)
OPERATIONS HANDBOOK

STA/T STEP	PROCEDURE	PANEL	REMARKS
19.2.4	Mode IV SPS Abort (09:41 to Insertion)		
AD 1	THC - CCW (4.0 sec min)	X X X X X	Direct ullage commanded when THC placed CCW. THC must be left in CCW detent for 4.0 seconds to allow 3.0-second timer (adapter separation) and 0.6-second timer (RCS enable) to operate.
00:00	Evt Tmr rset & counting up (auto)	X EVNT TMR RSET - RSET	RSET position is momentary.
	BECO (auto)	X EVNT TMR START - START X Request ground X command SIVB BECO	START position is momentary.
	LV ENG 1 lt - on Direct ullage started (auto)	X X DIR ULL pb - push X X X	If auto direct ullage present (THC-CCW), DIR ULL pb must not be activated (avoids tying together main bus A & B at DIP ULL pb).
00:03	Adapter sep (auto)	X CSM/LV SEP pb - push X X	Guarded.
CP 00:03.8	LV ENG 1 lt - out RCS/SCS enbl (auto)	X X RCS CMD - ON X X	ON position is momentary.
AD 2	LV IND/GPI sw - 3FI	X X X	Automatic direct ullage terminated when THC returned to center.
AD 3	THC - ARMED, ctr, damp rates, then +X Check SW FCC tbs	X DIR ULL pb - push X X	

MODE IV SPS ABORT (09:41 TO INSERTION)

ABORT

APOLLO-SOYUZ TEST PROJECT (ASTP)
OPERATIONS HANDBOOK

STA/T STEP	PROCEDURE	PANEL	REMARKS
CP 4	Key V82E N62E FL V16 N62 VI XXXXX FPS Hdot XXXXX FPS Hpad XXXX.X NM		
AC 00:24	5 Terminate +X trans		
6	If pitch profile burn mnyr to desired burn attitude		SEF, heads down. Slight movement of the GPI indicator (4) will be observed if SCS TVC (2) - RATE CMD.
7	Obtain insertion update		
8	EMAG MODE (3) - ATT 1/ RATE 2		
9	RATE - LO		
10	Verify SPS GMBL ind (2) = SPS GMBL tw (2) settings		
11	EMS MODE - NORM		Guarded.
12	ΔV THRUST A - NORM		
13	Perform burn If Pitch Profile Burn Start ullage (IGN -15 sec)		-H DOT, burn ASAP; +H DOT, burn at 1:30.
AC			

MODE IV SPS ABORT (09:41 TO INSERTION

APOLLO-SOYUZ TEST PROJECT (ASTP)
OPERATIONS HANDBOOK

STA/T STEP	PROCEDURE	PANEL	REMARKS
AC <1:30	SPS THRUST - DIR ON	X If no SPS IGN X ΔV THRUST B-NORM X If still no SPS IGN X THRUST ON pb-push	Lever lock.
	SCS TVC PITCH-RATE CMD	X	Bypasses noise problem in SCS gyro assemblies because of thrusting vibration levels and provides backup to auto selection of high rate in pitch and yaw TVC.
	RATE - HI	X	
	Terminate ullage -	X	
	IGN + 1 sec	X	
	EMAG MODE PITCH -	X	
	RATE 1	X	
	Fly H DOT to zero with	X	
	MTVC	X	
	Trim yaw with tv	X	
	Burn to desired VI	X If H DOT > 100 X Key Rel to N44 X (-H DOT) Burn X to H _p > 70 NM X + 4 sec X (+H DOT) Burn X to H _a > 200 NM, X then Apogee X kick	
	Go to 14	X	
	or If Fixed Att Burn	X	
01:50	Start ullage	X	

MODE IV SPS ABORT (09:41 TO INSERTION)

ABORT

19.2.4

APOLLO-SOYUZ TEST PROJECT (ASTP)
OPERATIONS HANDBOOK

STA/T STEP	PROCEDURE	PANEL	REMARKS
20.0	UNDOCKED EMERGENCY PROCEDURES		
	Emergency procedures provide the crew with the necessary steps to quickly alleviate situations that have (or will) become both crew-hazardous and time-critical. These procedures require instant reaction on the part of the crew to prevent the conditions from becoming worse. In most instances the conditions are physically sensed by the crew rather than brought to their attention by the caution and warning system or voice communication from STDN.		
20.1	PAD EMERGENCY PROCEDURES		
20.1.1	<u>Rapid Hatch Opening</u>		
CP	1 Gear box sel - UNLATCH (verify)	Side hatch	To accomplish rapid hatch opening after engaging latches, hatch must be configured for rapid egress as shown in Cabin Closeout, 2.1.5.
2	Actr handle rel - push or squeeze		
3	Actr handle - opr (until hatch is unlatched)		Lock pin will be sheared. About 5 cycles of actuator operation will open hatch.
	XXXXXXXXXXXXXXXXXXXXXXXXXXXXXXXXXXXXX X		
	If hatch fails to open		
	GN2 ratchet handle - opr		
	GN2 vlv handle - unlock & push (outbd)		
	XXXXXXXXXXXXXXXXXXXXXXXXXXXXXXXXXXXXX X		

20.1.1.1 RAPID HATCH OPENING

APOLLO-SOYUZ TEST PROJECT (ASTP)
OPERATIONS HANDBOOK

STA/T STEP	PROCEDURE	PANEL	REMARKS
20.2	UNDOCKED FLIGHT EMERGENCY PROCEDURES		
20.2.1	<u>Fire/Smoke in CM During Boost</u>		
CF 1	CAB FAN (both) - OFF (verify)	2	
DP 2	Monitor EPS indicators for excess current Immediately remove pwr from affected bus to prevent further damage to critical systems	3	
3	If in abort mode I or II SUIT COMPR 1 (or 2) - on good ac bus	4	
4	If in abort mode III & affected bus is MNA (or B) TVC GMBL DR (2) - 2 (or 1) INV 1 (or 2) AC1 (or 2) - OFF INV 2 (or 1) AC1 (or 2) - on (up)	1 3	Powers both ac buses with inverter from good main bus.
AC 5	rh CAB PRESS RELF vlv - DUMP (safety latch off)	325	
6	Continue appropriate abort		
20.2.2	<u>Fire/Smoke in CM - Orbital Operations</u>		
a. Suited Crew	CAB FAN (both) - OFF (verify)	2	
DP	Monitor EPS indicators for excess current. Immediately remove pwr from affected bus to prevent further damage to critical systems	3	

FIRE/SMOKE IN CM - ORBITAL OPERATIONS

APOLLO-SOYUZ TEST PROJECT (ASTP)
OPERATIONS HANDBOOK

STA/T STEP	PROCEDURE	PANEL	REMARKS
DP	SUIT COMPR 1 (or 2) - on good ac bus Fire extinguisher - use as appropriate Fire out	4	Water dispenser used on all open nonelectrical fires. Foam fire extinguisher used on fires behind panels, closed compartments, and electrical fires.
	<u>WARNING</u> Combustion products may be toxic. Smoke should be removed from cab per Contam in CM, 20.2.5 (step 3b), before removing helmets.		
AC	Fire persists Dump cabin as follows SUIT RETURN vlv - CLOSE (push) (verify)	380	
CP	EMER CAB PRESS sel - OFF (verify)	351	
AC	REPRESS PKG vlv - OFF (verify)	326	
ALL AC, CP	PGA - visual integrity check rh CAB PRESS RELF vlv - DUMP (safety latch off) until CAB PRESS ind 3.0 psia, then to BOOST/ENTR	325 2 325	Provides controlled cabin dump until suit circuit pressure verified.
AC CP	SUIT PRESS ind - holding > 3.5 psia (verify) rh CAB PRESS RELF vlv - DUMP &/or CAB PRESS DUMP Side hatch vlv - open (CCW) CAB PRESS ind - 0.0 psia for 6 min	2 325 2	Time period is a function of equipment oxygen exposure and saturation level.

20.2.2

FIRE/SMOKE IN CM - ORBITAL OPERATIONS

EP E GENY

APOLLO-SOYUZ TEST PROJECT (ASTP)
OPERATIONS HANDBOOK

STA/T STEP	PROCEDURE	PANEL	REMARKS
AC	rh CAB PRESS RELF vlv - NORM (safety latch on) & CAB PRESS DUMP vlv - close (CW)	325 Side hatch	
CP	<u>WARNING</u> Do not repress cab until fire source removed. Reignition may occur with additional damage. If condition lasts longer than 10 minutes, gly circulation & temp cont must be re-established.		
ALL	b. Unsuitd or Partially Suited Crew Don emer O2 mask (refer to Oper of Emer O2 Masks, 5.4.14)		
CP	CAB FAN (both) - OFF (verify)	2	
DP	SUIT COMPR (both) - OFF Monitor EPS indicators for excess current. Immediately remove pwr from affected bus to prevent further damage to critical systems Fire extinguisher - use as appropriate	4 3	Water dispenser used on all open nonelectrical fires. Foam fire extinguisher used on fires behind panels, closed compartments, and electrical fires.
	Fire out		
	<u>WARNING</u> Combustion products may be toxic. Smoke should be removed from cab per Contam in CM, 20.2.5 (step 3b), before removing O2 masks.		

FIRE/SMOKE IN CM - ORBITAL OPERATIONS

APOLLO-SOYUZ TEST PROJECT (ASTP)
OPERATIONS HANDBOOK

STA/T STEP	PROCEDURE	PANEL	REMARKS
ALL	Fire persists Don PGA except helmet (refer to PGA Mode Changes, 5.4.6)		O2 connections red-to-red and blue-to-blue. Use O2 masks as long as possible.
AC	DIRECT O2 vlv - OPEN (CCW)	7	Purges suit inlet manifold, suit hoses, and PGA portion of suit circuit.
ALL CP	Remove emer O2 mask & don helmet SUIT FLOW vlv (3) - 300,301,302 FULL FLOW		
DP	SUIT COMPR 1 (or 2) - ACi (or AC2)	4	
AC CP	DIRECT O2 vlv - close (CW) EMER CAB PRESS sel - OFF	7 351	
ALL AC	PGA - visual integrity check rh CAB PRESS RELF vlv - DUMP (safety latch off) until CAB PRESS ind 3.0 psia, then to BOOST/ENTR	325 2	Provides controlled cabin dump until suit circuit pressure verified.
AC CP	SUIT PRESS ind - holding >3.5 psia (verify) rh CAB PRESS RELF vlv - DUMP &/or CAB PRESS DUMP Side hatch vlv - open (CCW)	325 Side hatch	
AC	CAB PRESS ind - 0.0 psia for 6 min	2	Time period is a function of equipment oxygen exposure and saturation level.
AC	rh CAB PRESS RELF vlv - NORM (safety latch on) & CAB	325	
CP	PRESS DUMP vlv - close (CW) Side hatch	Side hatch	

20.2.2

FIRE/SMOKE IN CM - ORBITAL OPERATIONS

EMERGENCY

APOLLO-SOYUZ TEST PROJECT (ASTP)
OPERATIONS HANDBOOK

STA/T STEP	PROCEDURE	PANEL	REMARKS
	<p align="center"><u>WARNING</u></p> <p>Do not repress cab until fire source removed. Reignition may occur with additional damage. If condition lasts longer than 10 minutes, gly circulation and temp cont must be re-established.</p>		
	<p>20.2.3 <u>Fire/Smoke in CM During Entry</u></p>		
	<p>1 CAB FAN (both) - OFF (verify)</p>	2	
DP	<p>2 Monitor EPS indicators for excess current. Immediately remove pwr from affected bus to prevent further damage to critical systems</p>	3	
AC	<p>3 RHC PWR DIR (both) - MNA/MNB, & maintain att if req</p>	1	
DP	<p>4 If affected bus is MNA INV 1 AC1 - OFF INV 2 AC1 - on (up)</p>	3	<p>Powers both ac buses with inverter being powered from good dc main bus, providing ac power for suit compressors and SCS.</p> <p>System 1 is normal and system 2 is redundant.</p>
AC	<p>Set up for CM/RCS sys 2 (1) AUTO RCS A/C ROLL (4) - OFF AUTO RCS CM 1 (2) (6) - OFF AUTO RCS CM 2 (1) (6) - MNB</p>	8	

FIRE/SMOKE IN CM DURING ENTRY

APOLLO-SOYUZ TEST PROJECT (ASTP)
OPERATIONS HANDBOOK

STA/T STEP	PROCEDURE	PANEL	REMARKS
5	If affected bus is MNB INV 2 AC2 - OFF INV 1 AC2 - on (up)	3	Powers both ac buses with inverter being powered from good dc main bus, providing ac power for suit compressors and SCS.
	Set up for CM/RCS sys 2 (1) AUTO RCS A/C ROLL (4) - OFF AUTO RCS CM 1 (2) (6) - OFF AUTO RCS CM 2 (1) (6) - MNA	8	
6	rh CAB PRESS HELF viv - DUMP (safety latch off)	325	
7	Continue entry		
20.2.4	Not Applicable		
20.2.5	<u>Contamination in CM</u>		Types, sources, and amount of contamination are not defined. The very existence of contamination in CM is treated as an emergency.
ALL	1 Don emer O2 mask &/or PGA immediately (refer to Oper of Emer O2 Masks, 5.4.14 and PGA Mode Changes, 5.4.6)		
	2 Evaluate contam level, & isolate or correct source of contam		

20.2.5

CONTAMINATION IN CM

EMERGENCY

APOLLO-SOYUZ TEST PROJECT (ASTP)
OPERATIONS HANDBOOK

STA/T STEP	PROCEDURE	PANEL	REMARKS
3	If contam persists		
ALL	a. Accept contam level in cab		
AC	Retain O2 mask or remain in PGA	7	Slow removal of contamination accomplished with WASTE STOW valve (panel 252) in VENT position.
CP	If in PGA, adjust DIRECT O2 vlv for SUIT CAB AP >2 in. H2O	2	
ALL	b. Dump & repress cab		
	Retain or don PGA (refer to PGA Mode Changes, 5.4.6)		
	PGA - visual integrity check		
	Perform CM Press Dump, 5.4.11		
	Perform CM Repress, 5.4.8e		
	<u>20.2.6 Contamination in Suit (Suited Crewman)</u>		
DP	1 SUIT COMPR 2 - AC1	4	Contamination originates within suit circuit if, after purging with oxygen, contamination still present.
	2 SUIT COMPR 1 - OF.		
AC	3 DIRECT O2 vlv - OPEN (CCW) for 1 min, then close (CW)	7	
DP	4 If condition persists	4	
AC	SUIT COMPR 2 - OFF	7	
ALL	DIRECT O2 vlv - close (CW)		
	Doff helmet		
	Don emer O2 mask (refer to Oper of Emer O2 Masks, 5.4.14)		
	Determine contam cause		

CONTAMINATION IN SUIT (SUITED CREWMAN)

APOLLO-SOYUZ TEST PROJECT (ASTP)
OPERATIONS HANDBOOK

STA/T STEP	PROCEDURE	PANEL	REMARKS
20.2.7	<u>LET Fails to Jettison</u>		
AC	a. Tower Legs Cut/No jett mot ign LES MOT FIRE pb - push If tower jett successful	1	Guarded.
CP	TWR JETT (both) - OFF (ctr) Continue mission	2	Guarded.
	If tower jett unsuccessful TWR JETT (both) - OFF (ctr) Report to STDN & go for orbit		Guarded.
AC	b. No Response to TWR JETT Switches Verify the following	8	
	cb SECS ARM (2) - close		
	cb SECS LOGIC (2) - close		
	cb EDS (all) - close		
	SECS LOGIC (both) - on (up)		Lever lock.
	SECS PYRO ARM (2) - on (up)		Lever lock.
	EDS PWR - on (up)	7	
CP	TWR JETT (both) - on (up) If tower jett successful	2	Guarded. On (up) position is momentary.
	TWR JETT (both) - OFF (ctr) Continue mission		
	If tower jett unsuccessful TWR JETT (both) - OFF (ctr) Report to STDN & go for orbit		

20.2.7

LET FAILS TO JETTISON

APOLLO-SOYUZ TEST PROJECT (ASTP)
OPERATIONS HANDBOOK

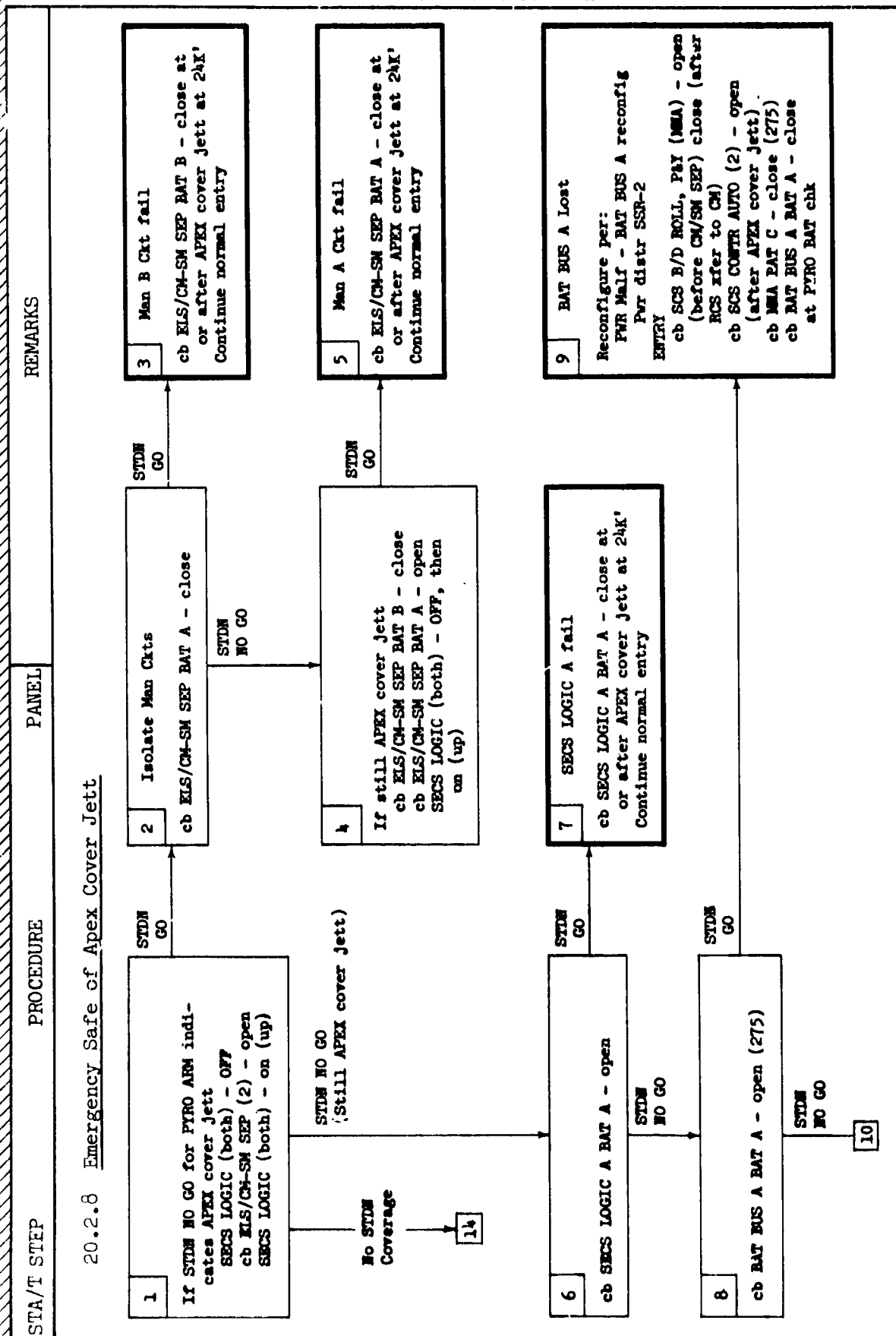

EMERGENCY SAFE OF APEX COVER JETT

APOLLO-SOYUZ TEST PROJECT (ASTP)
OPERATIONS HANDBOOK

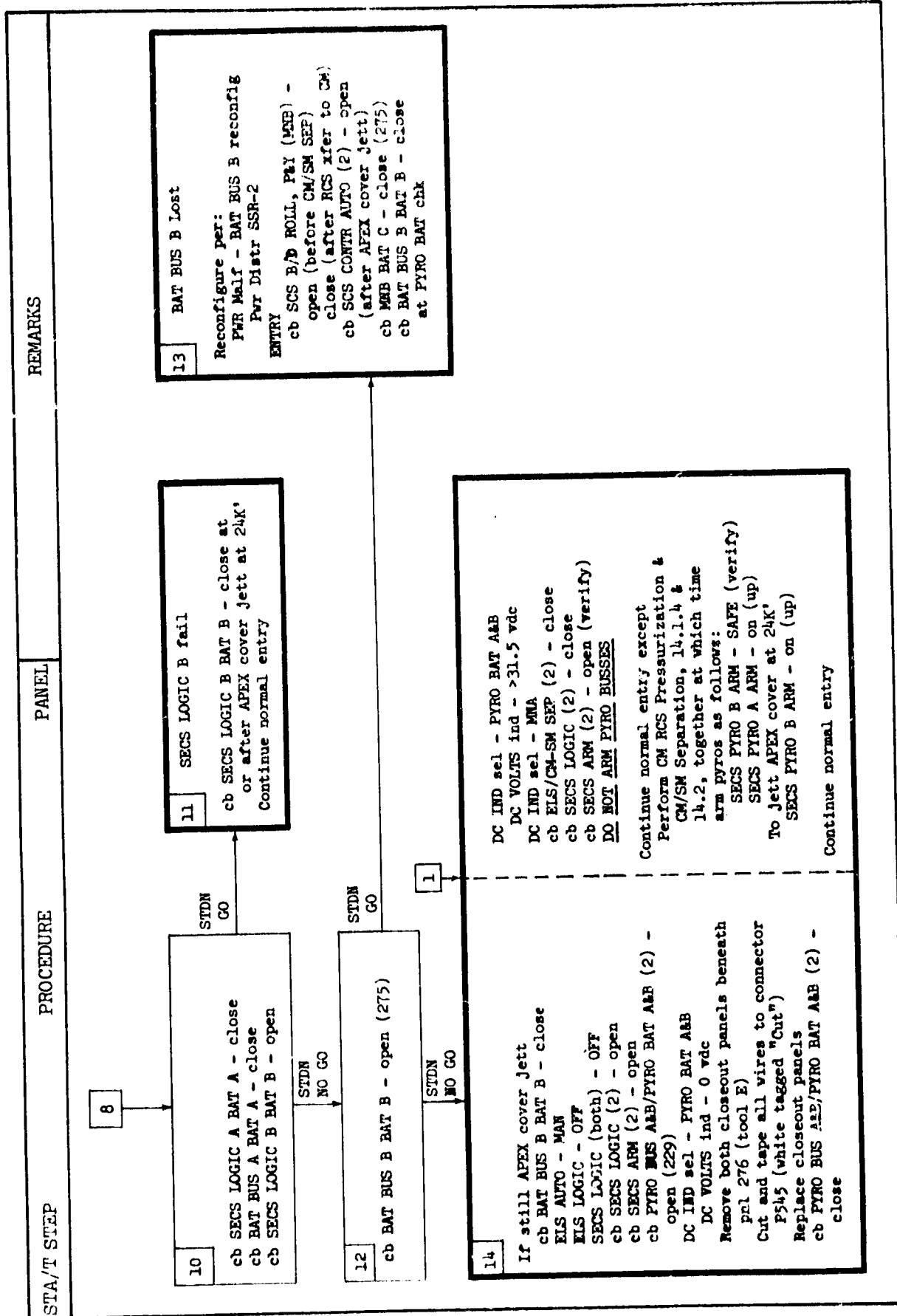

EMERGENCY SAFE OF APEX COVER JETT

EMERGENCY

20.2.8

APOLLO-SOYUZ TEST PROJECT (ASTP)
OPERATIONS HANDBOOK

STATE STEP	PROCEDURE	PANEL	REMARKS
20.2.9	<u>One Y Strut Will Not Fully Extend and Lock</u>		The other Y strut should be extended and locked as the following operations are performed.
AC	<ol style="list-style-type: none"> 1 Break lockwire on one Y strut adjustment jam nut of affected Y strut 2 Using tool F, unscrew jam nut 3 Disengage washer key so that strut bearing pad will turn 4 Screw strut bearing pad inboard until strut can be extended and locked 5 Replace washer key, & tighten jam nut 		Lockwire and key are not required for water landing.
20.2.10	<u>SM RCS Jet Failed On</u>		Either SC CONT (if in G&M or SCS) or THC (if in G&M) used to select other mode (CVC or SCS), not controlling jets.
	<ol style="list-style-type: none"> 1 Change to other control mode 2 RHC PWR DIR (both) - MNA/MNB RHC - null SC rates using dir RCS AUTO RCS (16) - OFF 	1 8	
	<p>If condition persists</p> <p>AUTO RCS (16) - MNA or MNB (as req)</p> <p>MAN ATT (3) - ACCEL CMD</p> <p>Null SC rates</p> <p>cb SCS DIR ULL (2) - open</p> <p>RHC PWR DIR (both) - OFF</p>	1 8 1	

SM RCS JET FAILED ON

APOLLO-SOYUZ TEST PROJECT (ASTP)
OPERATIONS HANDBOOK

STA/T STEP	PROCEDURE	PANEL	REMARKS
CP	If condition persists SM RCS PRPLNT (affected quad) - CLOSE	2	CLOSE position is momentary.
20.2.11	<u>CM RCS Fails to Pressurize or Feed Propellant</u>		
1	Verify elect for pressurization cb EPS BAT BUS (2) - close cb PYRO BUS A&B/PYRO BAT A&B (2) - close cb SECS ARM (2) - close SECS PYRO ARM (2) - on (up) SECS LOGIC (both) - on (up)	229 8	Lever lock. Lever lock.
2	Cycle CM RCS PRESS - on (up)	2	Guarded.
3	Verify elect to CM RCS prplnt vlvs cb EPS GRP 1 & 3 (4) - close cb RCS PRPLNT ISOL (2) - close	229 8	
4	Cycle CM RCS PRPLNT (both) - on (up)	2	
5	Open He and prplnt crossfeed cb EPS GRP 5 (2) - close cb RCS LOGIC (2) - close CM RCS LOGIC - on (up) CM PRPLNT DUMP - on (up) (momentarily) then OFF	229 8 1	Guarded. Once interconnected, systems cannot be isolated.

20.2.11

CM RCS FAILS TO PRESSURIZE OR FEED PROPELLANT

EMERGENCY

APOLLO-SOYUZ TEST PROJECT (ASTP)
OPERATIONS HANDBOOK

STA/T STEP	PROCEDURE	PANEL	REMARKS
20.2.12	FC 1 (2,3) C&W Light On		Fuel cell 1 (2,3) light may be illuminated by the following, less time critical failures:
DP	Check FC REACS tb (all) If FC 1 (2,3) REACS tb - gray	3	FC SKIN TEMP ind - >475°F or <360°F FC COND EXH TEMP ind - >175°F or <150°F FC pH HI tb - top (SKIN TEMP & COND EXH TEMP, can be verified by meters on panel 3.)
	Perform malfunction procedure Fuel cell symptom 1		Malfunction procedures are in the Flight Data File (FDF).
	If FC 1 (2,3) REACS tb - bp		If barber pole, rapid crew reaction is required to prevent fuel cell loss:
	FC 1 (2,3) REACS - on (up)		<20 seconds after H2 valve closure <90 seconds after O2 valve closure.
	If FC 1 (2,3) REACS tb still bp & flow -0		On (up) position is momentary.
	CAUTION When open circuiting one of three fuel cells ensure remaining fuel cells configured with one on each main bus		Flow verified on panel 3 meter.
	FC 1 (2,3) MNA & MNB - OFF		Removes fuel cell from main buses.
	Perform malfunction procedure Fuel cell symptom lh		Malfunction procedures are in the Flight Data File (FDF).

FC 1 (2,3) C&W LIGHT ON

APOLLO-SOYUZ TEST PROJECT (ASTP)
OPERATIONS HANDBOOK

STA/T STEP	PROCEDURE	PANEL	REMARKS
20.3	POSTLANDING EMERGENCY PROCEDURES		
20.3.1	<u>Fire/Smoke in CM During Postlanding</u>		
a.	Stable I		
ALL	Don emer O2 mask (refer to Oper of Emer O2 Masks, 5.4.14)	2	
AC	DIRECT O2 vlv - close (CW) (verify)	7	
CP	cb BAT BUS A&B BAT A&B (2) - open	275	
	cb BAT BUS A&B BAT C (2) - open		
	cb FLT/PL BUS BAT C - open	5	
	cb BAT CHGR BAT C/EDS 2 - open		
	cb PYRO BUS A&B PYRO BAT A&B (2) - open	229	
	Fire extinguisher - use as appropriate		Water dispenser used on all open nonelectrical fires. Foam fire extinguisher used on fires behind panels, closed compartments, and electrical fires.
&/or	Egress CM (refer to Stable I Water Egress Procedure, 16.4.2)		
b.	Stable II		
ALL	Don emer O2 mask (refer to Oper of Emer O2 Masks, 5.4.14)		
AC	DIRECT O2 vlv - close (CW) (verify)	7	
CP	Fire extinguisher - use as appropriate		Water dispenser used on all open nonelectrical fires. Foam fire extinguisher used on fires behind panels, closed compartments, and electrical fires.
	Upright CM to Stable I (refer to Postlanding Stabilization, Floating Inverted, 16.1) & proceed to step a		
	If CM fails to upright		
	Perform Stable II Water Egress Procedure, 16.4.3		
20.3.1			

FIRE/SMOKE IN CM DURING POSTLANDING

EMERGENCY

APOLLO-SOYUZ TEST PROJECT (ASTP)
OPERATIONS HANDBOOK

STA/T STEP	PROCEDURE	PANEL	REMARKS
CP	<p>If CAB PRESS ind & O2 FLOW ind remain stable, DM hatch is probably not integral</p> <p>If CAB PRESS ind decr & O2 FLOW ind incr, CM fwd hatch is probably not integral</p> <p>Press tunl using PRESS EQUAL vlv</p> <p>Remove fwd hatch, 5.7.1</p> <p>Check for foreign object(s) jammed in tunl/hatch, seal interface, or hatch seal damage</p> <p>Reposition fwd hatch against hatch seal interface</p> <p>Reinitiate tunl depress & hatch seal integrity check</p> <p>XXX</p> <p>2 Perform DM Jettison & Separation, 4.4</p> <p>3 Perform the following <u>TBD</u> prior to CM/SM separation to raise CM press to maximum design press of 8.6 psid</p> <p>CAB PRESS RELF vlv (2) - CLOSE</p> <p>REPRESS PKG vlv - OFF</p> <p>EMER CAB PRESS sel - OFF</p> <p>CAB PRESS vlv - OPEN (CW)</p> <p>REPRESS O2 VLV - CLOSE</p>	2	Fwd hatch
AC			325
CP			326
			351
			601

FORWARD HATCH CANNOT BE RE-INSTALLED

APOLLO-SOYUZ TEST PROJECT (ASTP)
OPERATIONS HANDBOOK

STA/T STEP	PROCEDURE	PANEL	REMARKS
CP	When CAB PRESS ind - 8.6 psia CAB REPRESS vlv - OFF (CCW) REPRESS PKG vlv - FILL	2 351 326	
60K'	4 Begin entry prep, 14.1 REPRESS 02 VLV - OPEN	601	Guarded. Provides an additional 3 psia in ~1-minute period.
AC	50K' Report CM stable XXXXXXXXXXXXXXXXXXXXXXXXXXXXX		
CP	CM unstable RCS CMD - OFF	2	OFF position is momentary.
AC	40K' APEX COVER JETT pb - push DROG DPLY pb - push (2 sec after apex cover jett) XXXXXXXXXXXXXXXXXXXXXXXXXXXXX	1	Guarded.
30K'	ELS LOGIC - on (up)		Guarded.
24K'	ELS AUTO - AUTO SCS RCS disable (auto)		
CP	XXXXXXXXXXXXXXXXXXXXXXXXXXXXX RCS CMD - OFF XXXXXXXXXXXXXXXXXXXXXXXXXXXXX	2	OFF position is momentary.
AC	Apex cover jett (auto) XXXXXXXXXXXXXXXXXXXXXXXXXXXXX APEX COVER JETT pb - push XXXXXXXXXXXXXXXXXXXXXXXXXXXXX	1	The apex cover will be jettisoned at 24K feet plus 0.4 second. Guarded.

FORWARD HATCH CANNOT BE RE-INSTALLED

21.1.1.1

APOLLO-SOYUZ TEST PROJECT (ASTP)
OPERATIONS HANDBOOK

STA/T STEP	PROCEDURE	PANEL	REMARKS
AC	Drogue chutes deployed (auto) XXXXXXXXXXXXXXXXXXXXXXXX X DROG DPLY pb - push XXXXXXXXXXXXXXXXXXXXXXXX XXXXXXXXXXXXXXXXXXXXXXXX If no drogue deployment. ELS AUTO - MAN Stabilize CM with direct RCS 5K' MN DPLY pb - push ELS AUTO - AUTO XXXXXXXXXXXXXXXXXXXXXXXX	1	Drogue parachutes deployed at 24K feet plus 2.0 seconds. The CM may be very unstable until the drogue chutes disreef in 11 seconds. Guarded.
CP 10K'	CAB PRESS ind - 10 psia Main chutes & VHF recovery antenna deploy (auto) MN DPLY pb - push CAUTION Exercise care in handling fwd hatch as it will be at a high temperature.	2	Indication of main chute deploy altitude. Auto deployment occurs between 10,950 and 9,100 feet. Parachutes disreef in 15 seconds after pilot mortars fire. Guarded.

FORWARD HATCH CANNOT BE RE-INSTALLED



APOLLO-SOYUZ TEST PROJECT (ASTP)
OPERATIONS HANDBOOK

STA/T STEP	PROCEDURE	PANEL	REMARKS
+20 sec	Immediately following main parachute disreefing, CP must egress from center couch and position himself in an optimum stance to support the fwd hatch (~85 lbs)		
	When C2 in position CAB PRESS DUMP vlv - open (CCW) (full open)	Side hatch	
	As press equalization allows fwd hatch to move, retrieve hatch & stow	Fwd hatch	
DP	CAB PRESS DUMP vlv - close (CW)	Side hatch	
	Set up entry comm VHF ANT - RECY VHF AM A - SIMPLEX VHF BCN - ON	3	If VHF AM B - SIMPLEX or VHF AM A - DUPLEX required, turn off beacon during period of transmission.
AC	Transmit voice (VHF AM) reporting Position Main chutes disreefed Splash error Crew status		Continue voice transmission until touchdown.
DP	Crew couch struts (4) - unlock cb FLT/PL BUS BAT A, B, & C (3) - close cb FLT/PL BUS MNA & B (2) - open cb SPS PITCH, YAW (4) - open	5	
AC		8	
3K'			

FORWARD HATCH CANNOT BE RE-INSTALLED

EL.1.1.1

APOLLO-SOYUZ TEST PROJECT (ASTP)
OPERATIONS HANDBOOK

STA/T STEP	PROCEDURE	PANEL	REMARKS
AC	FLOOD FIXED - POST LDG	8	Provides power from flight and postlanding bus to one floodlight in LH couch area and one floodlight in center couch area. Minimize floodlight use during postlanding. Maximum utilization should be 9.6 hours per 48-hour period.
	FLOOD DIM - 1 or 2		Position 1 provides power to two secondary floodlights and position 2 provides power to two primary floodlights when FLOOD FIXED switch in POST LDG position after dc main buses deactivated.
800' CP	CM RCS PRPLNT (both) - OFF	2	OFF position is momentary.
	CM RCS PRPLNT tb (both) - bp		Barber pole indicates at least one propellant isolation valve (fuel or oxidizer) closed in each particular system 1 or 2.
AC DP	DIRECT O2 vlv - OPEN (CCW) MN BUS TIE (2) - OFF	7 5	Removes battery power from dc main buses A and B.
	<u>CAUTION</u> MN BUS TIE switches must be left in the OFF position to ensure bat A, B, & C are used to pwr postlanding bus only, & to prevent bat shorting caused by water entering the CM feed-thru connectors. cb BAT RLY BUS (2) - open Postlanding Check, sec 16		

FORWARD HATCH CANNOT BE RE-INSTALLED

APOLLO-SOYUZ TEST PROJECT (ASTP)
OPERATIONS HANDBOOK

STA/T STEP	PROCEDURE	PANEL	REMARKS
21.1.2	<u>Fire/Smoke in CM - Docked Operations</u>		
	TBD		
21.1.3	<u>Time Critical Undocking & Separation</u>		
	TBD		
21.1.4	<u>Abnormal Vehicle Dynamics</u>		
	TBD		
21.2	<u>DM/SOYUZ DOCKED EMERGENCY PROCEDURES</u>		
21.2.1	<u>Time Critical Undocking & Separation</u>		
1	If hatch 3 closed, go to 3		Mixed crew returns permissible for time critical situations when crews are isolated in DM with hatch 3 closed.
	or Transfer to DM from SOYUZ		
	S J-BOX	S J-BOX	
	AUDIO POWER - OFF		
	Disconnect CCU		
	Enter DM		
(DM)	AUDIO 2 POWER - ON (verify)	818	
	Remove DM/SOYUZ Ventilation Duct		
	Deactivate DM/SOYUZ Umbilicals		
	cb SOYUZ POWER DMB - open	825	
	cb SOYUZ CABLE COMM (2) - open (SOYUZ)	TBD	
	Remove Umbilicals (3) (if time permits)		Except for drag through, DM/Soyuz umbilical disconnect not required.

21.2.1 TIME CRITICAL UNDOCKING & SEPARATION

APOLLO-SOYUZ TEST PROJECT (ASTP)
OPERATIONS HANDBOOK

STA/T STEP	PROCEDURE	PANEL	REMARKS
2	Close Hatch 3, 18.6.1 (step 3)		Tunnel 2 venting not mandatory.
3	Vent Tum'1 2 & Check Hatch 3 Integrity, 18.3.6, (if time permits)		Undocking with crew in DM permitted.
4	Undocking With Soyuz, CM Active, 18.1.2 Separate to safe distance		
5	Purge/Vent DM to 290 mm Hg 02 PURGE PRESS RELF vlv - AUTO PRESS RELF VLV REF - VACUUM 02 PURGE vlv - OPEN (ccw) 02 PART PRESS ind (2) - 300 mm Hg 02 PURGE vlv - close (cw) PRESS RELF VLV REF - DM 02 PURGE PRESS RELF - CLOSE LOW PRESS RELF vlv - AUTO PRESS RELF VLV REF - VACUUM CAB PRESS ind - 290 mm Hg PRESS RELF VLV REF - DM LOW PRESS RELF vlv - CLOSE	828 824 815 824 828 824 815 824 828	
6	Open Hatch 2, 18.6.1 Transfer to CM.		
21.2.2	<u>Fire, Smoke, Contaminants/DM at Soyuz Pressure</u>	TBD	
21.2.3	<u>Fire, Smoke, Contaminants/DM at CM Pressure</u>	TBD	

TIME CRITICAL UNDOCKING & SEPARATION

APOLLO-SOYUZ TEST PROJECT (ASTP)
OPERATIONS HANDBOOK

SYMPTOM	PROCEDURE	REMARKS
<p>21.2.4 Rapid Loss of DM Pressure</p> <p>1 RAPID LOSS OF DM PRESSURE</p>	<p>1</p> <ul style="list-style-type: none"> Notify other crewmembers to perform emergency procedures if required. CM Rapid Loss of cabin press or Soyuz Rapid Loss of Cabin Pressure HIGH PRESSURE RELIEF vlv (both) CLOSE (871) O₂ PURGE PRESS RELIEF vlv CLOSE (828) LOW PRESS RELIEF vlv CLOSE PRESS RELIEF VALVE REF OFF (874) DM/SOYUZ TUNL VENT ISOL vlv CLOSE (verify) (803) DM/SOYUZ TUNL VENT vlv CLOSE (verify) CYCLE FURNACE VENT vlv (2) OPEN/CLOSE (MEFS) Verify with CM DM VENT ISOLATION & DM VENT vlv CLOSED & TUNNEL PRESSURE RELIEF CAPPED (900) <p>Decay stops? (cabin press gage 815)</p> <p>2 LEAKING OR MISPOSITIONED VALVE</p> <p>3 MASK O₂ ON (828) • Don O₂ masks</p> <p>HATCHES 2 & 3 CLOSED</p> <p>4 DM STRUCTURAL LEAK DM > 6.2 PSI?</p> <p>5 Crews transfer to own S/C • Close HATCH 3 (decal)</p> <p>Decay stops?</p> <p>6 LO PRESS RELF vlv - AUTO PRESS RELF VLV REF YACUWM</p> <p>7 • Doff headsets & O₂ masks • Transfer to CM • Remove CM suit O₂ hoses from DM • Clos HATCH 2 (decal)</p> <p>Any residual VP across Hatch 2 will force the Hatch toward the DM when opened. Do not position yourself directly in front of Hatch when opening.</p> <p>8 SOYUZ LEAK</p> <p>9 • Monitor CM/DM VP, CM CAB PRESS & O₂ FLOW for CM Leak • If CM Leak Hatch 2 PRESS EQUAL vlv OPEN for added O₂ make up • Don PGAs</p> <p>10 HATCH 2 PRESS EQUAL vlv OPEN (crew) When DM CM VP 0 mmHg, open Hatch 2 • Doff headsets & O₂ masks • Transfer to CM • CLOSE HATCH 2 (decal)</p> <p>11 When DM PPO₂ & cabin pressure normal • Doff O₂ masks • MASK O₂ OFF (828)</p>	<p>1 HIGH O₂ FLOW (1) will come on at cabin pressure < 238mmHg. PPO₂ LI may also come on.</p> <p>2 Perform DM ECS mal function procedure one vehicle at a time to isolate leak.</p> <p>3 Prevents DM high nitrogen content entering CM before opening Hatch 2 PRESS EQUAL vlv.</p> <p>4 U.S. crew standby Soyuz leak rate and leak reparability will determine if Soyuz crew transfer to DM required.</p>

RAPID LOSS OF DM PRESSURE

EMERGENCY

21.2.4

SM 2A 2486 A

APPENDIX A

CM PANEL ILLUSTRATIONS AND CONTROL/INDICATOR CONFIGURATION LIST FOR CSM 119

This section contains CM panel illustrations and a control/indicator configuration list for CSM 119. Panel illustrations present the location of the displays and controls as they appear on the panels in the CM. The control/indicator configuration list provides the configuration of the CM displays and controls prior to backup crew cabin ingress, at lift-off, docked to Soyuz, and entry preparation. Entry preparation is defined as those functions that are required to be performed to place the vehicle in a posture to perform a deorbit burn. Those talkbacks (tb) are included which reflect the last position selected of spring-loaded switches. (Talkback indicators that are operated by sensors will not be listed.) The CSM control/indicator configuration list presents the panels in numerical sequence. The switches are not to be sequentially positioned as listed.

APOLLO-SOYUZ TEST PROJECT (ASTP)
OPERATIONS HANDBOOK

CSM CONTROL/INDICATOR CONFIGURATION				
NOMENCLATURE	PRIOR TO BACKUP CREW CABIN INGRESS	AT LIFTOFF	DOCKED TO SOYUZ	ENTRY PREPARATION
	PANEL 1			
EMS FUNC	OFF	AV	OFF	AV
EMS MODE	STBY	STBY	STBY	STBY
GTA SW	off (down)	off (down)	off (down)	N/A
EMS GTA COVER	Secure	Secure	N/A	N/A
CMC ATT	IMU	IMU	IMU	IMU
FDAI SCALE	5/1	5/5	5/1	5/1
FDAI SFL	1/2	1/2	1/2	1/2
FDAI SOURCE	CMC	CMC	CMC	CMC
ATT SET	GDC	GDC	GDC	GDC
MAN ATT ROLL	RATE CMD	RATE CMD	RATE CMD	RATE CMD
MAN ATT PITCH	ACCEL CMD	ACCEL CMD	RATE CMD	RATE CMD
MAN ATT YAW	RATE CMD	RATE CMD	RATE CMD	RATE CMD
LIM CYCLE	OFF	OFF	OFF	OFF
ATT DBD	MIN	MIN	MAX	MIN
RATE	HI	HI	HI	LO
THC PWR	OFF	on (up)	OFF	on (up)
RHC PWR NORM 1	OFF	AC/DC	OFF	AC/DC
RHC PWR NORM 2	OFF	AC/DC	OFF	AC/DC
RHC PWR DIR 1	OFF	MVA/MNB	OFF	MVA/MNB
RHC PWR DIR 2	OFF	MVA/MNB	OFF	MVA/MNB
SC CONT	SCS	SCS	SCS	CMC
CMC MODE	FREE	FREE	FREE	FREE
BMAG MODE ROLL	RATE 2	RATE 1	RATE 1	RATE 2
BMAG MODE PITCH	RATE 2	RATE 1	RATE 1	RATE 2
BMAG MODE YAW	RATE 2	RATE 1	RATE 1	RATE 2
SPS THRUST	NORM (locked)	NORM (locked)	NORM (locked)	NORM (locked)
AV THRUST A	OFF (guarded)	OFF (guarded)	OFF (guarded)	NORM
AV THRUST B	OFF (guarded)	OFF (guarded)	OFF (guarded)	NORM
SCS TVC PITCH	RATE CMD	AUTO	RATE CMD	RATE CMD
SCS TVC YAW	RATE CMD	AUTO	RATE CMD	RATE CMD

APOLLO-SOYUZ TEST PROJECT (ASTP)
OPERATIONS HANDBOOK

GMBL MOT P1	OFF	OFF	OFF	OFF	OFF
GMBL MOT P2	OFF	OFF	OFF	OFF	OFF
GMBL MOT Y1	OFF	OFF	OFF	OFF	OFF
GMBL MOT Y2	OFF	OFF	OFF	OFF	OFF
ATVC GALT	LO	LO	LO	LO	LO
ELS LOGIC	OFF (guarded)	OFF (guarded)	OFF (guarded)	OFF (guarded)	OFF (guarded)
ELS AUTO	MAN	MAN	MAN	MAN	MAN
CM RCS LOGIC	OFF	OFF	OFF	OFF	OFF
CM PRPLNT DUMP	OFF (guarded)	OFF (guarded)	OFF (guarded)	OFF (guarded)	OFF (guarded)
CM PRPLNT PURG	off (guarded)	off (guarded)	off (guarded)	off (guarded)	off (guarded)
IMU CAGE	off (down)	off (down)	off (down)	off (down)	off (down)
	(guarded)	(guarded)	(guarded)	(guarded)	(guarded)
EMS ROLL	OFF	OFF	OFF	OFF	OFF
.05 G SW	OFF	OFF	OFF	OFF	OFF
Pc IND SW	Pc	Pc	Pc	Pc	Pc
LV IND/GPI SW	SIVB	SIVB	SIVB	SIVB	SIVB
TVC GMBL DR PITCH	AUTO	AUTO	AUTO	AUTO	AUTO
TVC GMBL DR YAW	AUTO	AUTO	AUTO	AUTO	AUTO
EVNT TMR RSET	up (ctr)	up (ctr)	up (ctr)	up (ctr)	up (ctr)
EVNT TMR START	ctr	ctr	ctr	ctr	ctr
EVNT TMR MIN	ctr	ctr	ctr	ctr	ctr
EVNT TMR SEC	ctr	ctr	ctr	ctr	ctr
PANEL 2					
PL VENT VLV	push (lock)	push (lock)	push (lock)	push (lock)	push (lock)
PROBE EXTID/REL	OFF (guarded)	OFF (guarded)	OFF (guarded)	OFF (guarded)	OFF (guarded)
PROBE EXTID/REL A tb	gray	gray	gray	gray	gray
PROBE EXTID/REL B tb	gray	gray	gray	gray	gray
PROBE RETR PRIM	OFF	OFF	OFF	OFF	OFF
PROBE RETR SEC	OFF	OFF	OFF	OFF	OFF
GUIDE RING A	off (ctr)	off (ctr)	off (ctr)	off (ctr)	off (ctr)
	(RETR*)	(RETR*)	(RETR*)	(RETR*)	(RETR*)
GUIDE RING B	off (ctr)	off (ctr)	off (ctr)	off (ctr)	off (ctr)
	(RETR*)	(RETR*)	(RETR*)	(RETR*)	(RETR*)
STRUCT LATCH A	off (ctr)	off (ctr)	off (ctr)	off (ctr)	off (ctr)
	(OPEN*)	(OPEN*)	(OPEN*)	(OPEN*)	(OPEN*)
	(guarded)	(guarded)	(guarded)	(guarded)	(guarded)

*Identifies last momentary position switched to.

** (OPEN*) When docking performed with CSM passive

PANELS 1 AND 2

APOLLO-SOYUZ TEST PROJECT (ASTP)
OPERATIONS HANDBOOK

CSM CONTROL/INDICATOR CONFIGURATION				
NOMENCLATURE	PRIOR TO BACKUP CREW CABIN INGRESS	AT LIFTOFF	DOCKED TO SOYUZ	ENTRY PREPARATION
	PANEL 2 (CONT)			
STRUCT LATCH B	off (ctr) (OPEN*) (guarded)	off (ctr) (OPEN*) (guarded)	off (ctr) (OPEN*) (guarded)	off (ctr) (OPEN*) (guarded)
CAPTURE LATCH A	off (down)	off (down)	off (down)	off (down)
CAPTURE LATCH B	off (down)	off (down)	off (down)	off (down)
BACKUP PASSIVE A	off (ctr) (RESET*) (guarded)	off (ctr) (RESET*) (guarded)	off (ctr) (RESET*) (guarded)	off (ctr) (RESET*) (guarded)
BACKUP PASSIVE B	off (ctr) (RESET*) (guarded)	off (ctr) (RESET*) (guarded)	off (ctr) (RESET*) (guarded)	off (ctr) (RESET*) (guarded)
RCS IND sel	PSM	SMD	SMD	SMD
UP TLM CA	ELOCK	BLOCK	BLOCK	BLOCK
CM RCS PRESS	off (down) (guarded)	off (down) (guarded)	off (down) (guarded)	off (down) (guarded)
SM RCS IND sw	He TK TEMP	He TK TEMP	He TK TEMP	He TK TEMP
SM RCS QUAD A He tb	ctr (CLOSE*)	ctr (OPEN*)	ctr (OPEN*)	ctr (OPEN*)
SM RCS QUAD A He tb	bp	gray	gray	gray
SM RCS QUAD B He tb	ctr (CLOSE*)	ctr (OPEN*)	ctr (OPEN*)	ctr (OPEN*)
SM RCS QUAD B He tb	bp	gray	gray	gray
SM RCS QUAD C He tb	ctr (CLOSE*)	ctr (OPEN*)	ctr (OPEN*)	ctr (OPEN*)
SM RCS QUAD C He tb	bp	gray	gray	gray
SM RCS QUAD D He tb	ctr (CLOSE*)	ctr (OPEN*)	ctr (OPEN*)	ctr (OPEN*)
SM RCS QUAD D He tb	bp	gray	gray	gray
SM RCS A PSM PRPLNT tb	ctr (CLOSE*)	ctr (CLOSE*)	ctr (CLOSE*)	ctr (CLOSE*)
SM RCS A PSM PRPLNT tb	bp	bp	bp	bp
SM RCS B PSM PRPLNT tb	ctr (CLOSE*)	ctr (CLOSE*)	ctr (CLOSE*)	ctr (CLOSE*)
SM RCS B PSM PRPLNT tb	bp	bp	bp	bp
SM RCS C PSM PRPLNT tb	ctr (CLOSE*)	ctr (CLOSE*)	ctr (CLOSE*)	ctr (CLOSE*)
SM RCS C PSM PRPLNT tb	bp	bp	bp	bp

APOLLO-SOYUZ TEST PROJECT (ASTP)
OPERATIONS HANDBOOK

SM RCS D PSM PRPLNT	ctr (CLOSE*)	ctr (CLOSE*)	ctr (CLOSE*)	ctr (CLOSE*)
SM RCS D PSM PRPLNT tb	bp	bp	bp	bp
SM RCS QUAD A PRPLNT	ctr (CLOSE*)	ctr (OPEN*)	ctr (OPEN*)	ctr (OPEN*)
SM RCS QUAD A PRIM PRPLNT tb	bp	gray	gray	gray
SM RCS QUAD A SEC PRPLNT tb	bp	gray	gray	gray
SM RCS QUAD B PRPLNT	ctr (CLOSE*)	ctr (OPEN*)	ctr (OPEN*)	ctr (OPEN*)
SM RCS QUAD B PRIM PRPLNT tb	bp	gray	gray	gray
SM RCS QUAD B SEC PRPLNT tb	bp	gray	gray	gray
SM RCS QUAD C PRPLNT	ctr (CLOSE*)	ctr (OPEN*)	ctr (OPEN*)	ctr (OPEN*)
SM RCS QUAD C PRIM PRPLNT tb	bp	gray	gray	gray
SM RCS QUAD C SEC PRPLNT tb	bp	gray	gray	gray
SM RCS QUAD D PRPLNT	ctr (CLOSE*)	ctr (OPEN*)	ctr (OPEN*)	ctr (OPEN*)
SM RCS QUAD D PRIM PRPLNT tb	bp	gray	gray	gray
SM RCS QUAD D SEC PRPLNT tb	bp	gray	gray	gray
RCS CMD	ctr (OFF*)	ctr (OFF*)	ctr (OFF*)	ctr (OFF*)
RCS TRNFR	ctr (SM*)	ctr (SM*)	ctr (SM*)	ctr (SM*)
CM RCS 1 PRPLNT	ctr (OFF*)	ctr (on, up*)	ctr (on, up*)	ctr (on, up*)
CM RCS 2 PRPLNT	bp	gray	gray	gray
CM RCS 2 PRPLNT tb	ctr (OFF*)	ctr (on, up*)	ctr (on, up*)	ctr (on, up*)
RCS A SEC FUEL PRESS	bp	gray	gray	gray
RCS B SEC FUEL PRESS	ctr (OPEN*)	ctr (CLOSE*)	ctr (CLOSE*)	ctr (CLOSE*)
RCS C SEC FUEL PRESS	ctr (OPEN*)	ctr (CLOSE*)	ctr (CLOSE*)	ctr (CLOSE*)
RCS D SEC FUEL PRESS	ctr (OPEN*)	ctr (CLOSE*)	ctr (CLOSE*)	ctr (CLOSE*)
EDS AUTO	OFF	on (up)	off (down)	OFF
DOCK RING SEP 1	off (down)	off (down)	off (down)	off (down)
	(guarded)	(guarded)	(guarded)	(guarded)
DOCK RING SEP 2	off (down)	off (down)	off (down)	off (down)
	(guarded)	(guarded)	(guarded)	(guarded)
CM/SM SEP 1	off (down)	off (down)	off (down)	off (down)
	(guarded)	(guarded)	(guarded)	(guarded)
CM/SM SEP 2	off (down)	off (down)	off (down)	off (down)
	(guarded)	(guarded)	(guarded)	(guarded)
SIVB/DM SEP	off (down)	off (down)	off (down)	off (down)
	(guarded)	(guarded)	(guarded)	(guarded)

*Identifies last momentary position switched to.

PANEL 2

APOLLO-SOYUZ TEST PROJECT (ASTP)
OPERATIONS HANDBOOK

CSM CONTROL/INDICATOR CONFIGURATION				
NOMENCLATURE	PRIOR TO BACKUP CREW CABIN INGRESS	AT LIFTOFF	DOCKED TO SOYUZ	ENTRY PREPARATION
	PANEL 2 (CONT)			
PRPLNT DUMP	AUTO	AUTO	RCS CMD	RCS CMD
2 ENG OUT SW	AUTO	AUTO	OFF	OFF
LV RATES SW	AUTO	AUTO	OFF (ctr)	OFF (ctr)
TWR JETT 1	AUTO (guarded)	AUTO (guarded)	OFF (ctr) (guarded)	OFF (ctr) (guarded)
TWR JETT 2	AUTO (guarded)	AUTO (guarded)	OFF (ctr) (guarded)	OFF (ctr) (guarded)
LV GUID SW	IU	IU	IU	IU
MAIN REL	off (down) (guarded)	off (down) (guarded)	off (down) (guarded)	off (down) (guarded)
MSN TMR HRS	ctr	ctr	ctr	ctr
MSN TMR MIN	ctr	ctr	ctr	ctr
MSN TMR SEC	ctr	ctr	ctr	ctr
C/W NORM	NORM	BOOST	ACK	NORM
C/W CSM	CSM	CSM	CSM	CSM
C/W PWR	1	1	1	1
C/W LAMP TEST	ctr	ctr	ctr	ctr
C/W MEMORY	ctr (RSET*)	ctr (RSET*)	ctr (RSET*)	ctr (RSET*)
MSN TMR	STOP	START	START	START
RCS IND sel	CM 2	SM D	SM D	as desired
CAB FAN 1	OFF	OFF	OFF	OFF
CAB FAN 2	OFF	OFF	OFF	OFF
H2 HTRS 1	AUTO	AUTO	AUTO	off (ctr)
H2 HTRS 2	AUTO	AUTO	AUTO	off (ctr)
02 PRESS IND SW	1	SRG	SRG	SRG
02 HTRS 1	AUTO	AUTO	AUTO	off (ctr)
02 HTRS 2	AUTO	AUTO	AUTO	off (ctr)
H2 FANS 1	AUTO	AUTO	AUTO	off (ctr)
H2 FANS 2	AUTO	AUTO	AUTO	off (ctr)

APOLLO-SOYUZ TEST PROJECT (ASTP)
OPERATIONS HANDBOOK

ECS IND sel	PRIM	PRIM	PRIM	PRIM	PRIM	PRIM	PRIM	PRIM	PRIM
RAD FLOW CONT AUTO	AUTO	AUTO	AUTO	AUTO	AUTO	AUTO	AUTO	AUTO	AUTO
ECS RAD tb	gray	gray	gray	gray	gray	gray	gray	gray	gray
RAD FLOW CONT PWR	off (ctr)	off (ctr)	off (ctr)	off (ctr)	off (ctr)	off (ctr)	off (ctr)	off (ctr)	off (ctr)
RAD MAN SEL	RAD 1	RAD 1	RAD 1	RAD 1	RAD 1	RAD 1	RAD 1	RAD 1	RAD 1
RAD PRIM HTR	off (ctr)	off (ctr)	off (ctr)	off (ctr)	off (ctr)	off (ctr)	off (ctr)	off (ctr)	off (ctr)
RAD SEC HTR	OFF	OFF	OFF	OFF	OFF	OFF	OFF	OFF	OFF
POT H2O HTR	OFF	OFF	OFF	OFF	OFF	OFF	OFF	OFF	OFF
SUIT H2O ACCUM AUTO	ctr	ctr	ctr	ctr	ctr	ctr	ctr	ctr	ctr
SUIT H2O ACCUM ON	ctr	ctr	ctr	ctr	ctr	ctr	ctr	ctr	ctr
SEC COOL EVAP	off (ctr)	off (ctr)	off (ctr)	off (ctr)	off (ctr)	off (ctr)	off (ctr)	off (ctr)	off (ctr)
SEC COOL PUMP	AC2	AC2	AC2	AC2	AC2	AC2	AC2	AC2	AC2
SEC EVAP H2O FLOW	off (ctr)	off (ctr)	off (ctr)	off (ctr)	off (ctr)	off (ctr)	off (ctr)	off (ctr)	off (ctr)
GLY EVAP IN TEMP	MAN	MAN	MAN	MAN	MAN	MAN	MAN	MAN	MAN
GLY EVAP SIM AUTO	MAN	MAN	MAN	MAN	MAN	MAN	MAN	MAN	MAN
GLY EVAP SIM INCR	ctr	ctr	ctr (vlv partially open)	ctr	ctr	ctr	ctr	ctr	ctr
GLY EVAP H2O FLOW	off (ctr)	off (ctr)	off (ctr)	off (ctr)	off (ctr)	off (ctr)	off (ctr)	off (ctr)	off (ctr)
H2O QTY IND sw	POT	POT	POT	POT	POT	POT	POT	POT	POT
SM H2O TANK	CLOSE	CLOSE	CLOSE	CLOSE	CLOSE	CLOSE	CLOSE	CLOSE	CLOSE
SM RCS PSM He	ctr (CLOSE*)	ctr (CLOSE*)	ctr (CLOSE*)	ctr (CLOSE*)	ctr (CLOSE*)	ctr (CLOSE*)	ctr (CLOSE*)	ctr (CLOSE*)	ctr (CLOSE*)
SM RCS PSM He tb	bp	bp	bp	bp	bp	bp	bp	bp	bp
SM RCS PSM MANF ISOL	ctr (CLOSE*)	ctr (CLOSE*)	ctr (CLOSE*)	ctr (CLOSE*)	ctr (CLOSE*)	ctr (CLOSE*)	ctr (CLOSE*)	ctr (CLOSE*)	ctr (CLOSE*)
SM RCS PSM MANF ISOL tb	bp	bp	bp	bp	bp	bp	bp	bp	bp
VHF ANT	SM LEFT	SM LEFT	SM LEFT	SM LEFT	SM LEFT	SM LEFT	SM LEFT	SM LEFT	SM LEFT
SPS INJ VLV A1 ind	CLOSE	CLOSE	CLOSE	CLOSE	CLOSE	CLOSE	CLOSE	CLOSE	CLOSE
SPS INJ VLV A2 ind	CLOSE	CLOSE	CLOSE	CLOSE	CLOSE	CLOSE	CLOSE	CLOSE	CLOSE
SPS INJ VLV B3 ind	CLOSE	CLOSE	CLOSE	CLOSE	CLOSE	CLOSE	CLOSE	CLOSE	CLOSE

PANEL 3

PANELS 2 THRU 3

APOLLO-SOYUZ TEST PROJECT (ASTP)
OPERATIONS HANDBOOK

CSM CONTROL/INDICATOR CONFIGURATION				
NOMENCLATURE	PRIOR TO BACKUP CREW CABIN INGRESS	AT LIFTOFF	DOCKED TO SOYUZ	ENTRY PREPARATION
	PANEL 3			
SPS INJ VLV B4 ind	CLOSE	CLOSE	CLOSE	CLOSE
FC 1 PAD	off (ctr) (NORM*)	off (ctr) (NORM*)	off (ctr) (NORM*)	off (ctr) (NORM*)
FC 1 RAD tb	gray off (ctr) (NORM*)	gray off (ctr) (NORM*)	gray off (ctr) (NORM*)	gray off (ctr) (NORM*)
FC 2 RAD	gray off (ctr) (NORM*)	gray off (ctr) (NORM*)	gray off (ctr) (NORM*)	gray off (ctr) (NORM*)
FC 2 RAD tb	gray off (ctr) (NORM*)	gray off (ctr) (NORM*)	gray off (ctr) (NORM*)	gray off (ctr) (NORM*)
FC 3 RAD	gray off (ctr) (NORM*)	gray off (ctr) (NORM*)	gray off (ctr) (NORM*)	gray off (ctr) (NORM*)
FC 3 RAD tb	gray on (up)	gray on (up)	gray on (up)	gray on (up)
FC 1 HTRS	on (up)	on (up)	on (up)	on (up)
FC 2 HTRS	on (up)	on (up)	on (up)	on (up)
FC 3 HTRS	on (up)	on (up)	on (up)	on (up)
FC IND sel	1	1	1	1
SPS QTY TEST	ctr	ctr	ctr	ctr
OXID FLOW VLV INCR	NORM	NORM	NORM	NORM
OXID FLOW VLV PRIM	PRIM	PRIM	PRIM	PRIM
PUG MODE	NORM	NORM	NORM	NORM
FC 1 PURG	OFF	OFF	OFF	OFF
FC 2 PURG	OFF	OFF	OFF	OFF
FC 3 PURG	OFF	OFF	OFF	OFF
SM PWR SOURCE 1 MNA	OFF	ctr (on,up*)	ctr (on,up*)	ctr (on, up*)
SM PWR SOURCE 1 MNA tb	bp	gray	gray	gray
SM PWR SOURCE 2 MNA	ctr (on,up*)	ctr (on,up*)	ctr (on,up*)	ctr (on,up)
SM PWR SOURCE 2 MNA tb	gray	gray	gray	gray
SM PWR SOURCE 3 MNA	OFF	OFF	OFF	OFF
SM PWR SOURCE 3 MNA tb	bp	bp	bp	bp
MNA RSET	ctr (RSET*)	ctr (RSET*)	ctr (RSET*)	ctr (RSET*)
SPS He VLV 1	AUTO	AUTO	AUTO	AUTO
SPS He VLV 1 tb	bp	bp	bp	bp

APOLLO-SOYUZ TEST PROJECT (ASTP)
OPERATIONS HANDBOOK

	AUTO	AUTO	AUTO	AUTO
SPS He VLV 2	bp	bp	bp	bp
SPS He VLV 2 tb	OXID LN	OXID LN	OXID LN	OXID LN
SPS TEMP IND sw	He	He	He	He
SPS PRESS IND sw	ctr (on, up*)	ctr (on, up*)	ctr (on, up*)	ctr (on, up*)
FC 1 REACS	gray	gray	gray	gray
FC 1 REACS tb	ctr (on, up*)	ctr (on, up*)	ctr (on, up*)	ctr (on, up*)
FC 2 REACS	gray	gray	gray	gray
FC 2 REACS tb	ctr (on, up*)	ctr (on, up*)	ctr (on, up*)	ctr (on, up*)
FC 3 REACS	gray	gray	gray	gray
FC 3 REACS tb	ctr (on, up*)	ctr (on, up*)	ctr (on, up*)	ctr (on, up*)
SM PWR SOURCE 1 MNB	OFF	OFF	OFF	OFF
SM PWR SOURCE 1 MNB tb	bp	bp	bp	bp
SM PWR SOURCE 2 MNB	OFF	OFF	OFF	OFF
SM PWR SOURCE 2 MNB tb	bp	bp	bp	bp
SM PWR SOURCE 3 MNB	OFF	OFF	OFF	OFF
SM PWR SOURCE 3 MNB tb	bp	bp	bp	bp
MNB RSET	ctr (RSET*)	ctr (RSET*)	ctr (RSET*)	ctr (RSET*)
DC IND sel	MNA	MNA	MNA	MNA
BAT CHG	OFF	OFF	OFF	OFF
S BD XPNDR	OFF	PRIM	PRIM	PRIM
S BD PWR AMPL PRIM	PRIM	PRIM	PRIM	PRIM
S BD PWR AMPL HI	off (ctr)	LO	LO	LO
PWR AMPL tb	bp	gray	gray	gray
S BD MODE VOICE	VOICE	VOICE	VOICE	VOICE
S BD MODE PCM	PCM	PCM	PCM	PCM
S BD MODE RNG	RNG	RNG	RNG	RNG
S BD AUX TAPE	ctr	ctr	ctr	ctr
S BD AUX TV	ctr	ctr	ctr	ctr
UP TLM DATA	DATA	DATA	DATA	DATA
UP TLM CMD	OFF	NORM	NORM	NORM
S BD ANT OMNI A	B	as req	as req	as req
S BD ANT OMNI	OMNI	as req	as req	as req

* Identifies last momentary position switched to.

PANEL 3

APOLLO-SOYUZ TEST PROJECT (ASTP)
OPERATIONS HANDBOOK

CSM CONTROL/INDICATOR CONFIGURATION				
NOMENCLATURE	PRIOR TO BACKUP CREW CABIN INGRESS	AT LIFTOFF	DOCKED TO SOYUZ	ENTRY PREPARATION
	PANEL 3 (CONT)			
VHF AM SQLCH A tw	noise +1	noise +1	noise +1	noise +1
VHF AM A	off (ctr)	off (ctr)	off (ctr)	SIMPLEX
VHF AM B	off (ctr)	DUPLEX	off (ctr)	off (ctr)
VHF AM RCV	off (ctr)	off (ctr)	off (ctr)	off (ctr)
VHF BCN	OFF	OFF	OFF	OFF
VHF RNG	OFF	OFF	OFF	OFF
S BD SQLCH	ENBL	ENBL	ENBL	ENBL
FC REAC VLVS	NORM	LATCH	NORM	NORM
H2 PURG LINE HTR	OFF	OFF	OFF	OFF
VHF AM SQLCH B tw	noise +1	noise +1	noise +1	noise +1
TAPE RCDR PCM	PCM/ANLG	PCM/ANLG	PCM/ANLG	PCM/ANLG
TAPE RCDR RCD	RCD	RCD	RCD	RCD
TAPE RCDR FWD	off (ctr)	FWD	FWD	FWD
TAPE MOTION tb	bp	gray	(STDN command)	gray
SCE PWR	NORM	NORM	NORM	NORM
PMP PWR	NORM	NORM	NORM	NORM
PCM BIT RATE	HI	HI	LO	LO
PIT BU	NORM	NORM	NORM	NORM
INV 1	MNA	MNA	MNA	MNA
INV 2	MNB	MNB	MNB	MNB
INV 3	OFF	OFF	OFF	OFF
INV 1 AC1	on (up)	on (up)	on (up)	on (up)
INV 2 AC1	OFF	OFF	OFF	OFF
INV 3 AC1	OFF	OFF	OFF	OFF
AC1 RSET	ctr (RSET*)	ctr (RSET*)	ctr (RSET*)	ctr (RSET*)
INV 1 AC2	OFF	OFF	OFF	OFF
INV 2 AC2	on (up)	on (up)	on (up)	on (up)
INV 3 AC2	OFF	OFF	OFF	OFF
AC2 RSET	ctr (RSET*)	ctr (RSET*)	ctr (RSET*)	ctr (RSET*)
AC IND sel	BUS 2 \emptyset C	BUS 2 \emptyset C	BUS 2 \emptyset C	BUS 2 \emptyset C

APOLLO-SOYUZ TEST PROJECT (ASTP)
OPERATIONS HANDBOOK

PANEL 4				
SPS GAUGING	OFF	OFF	OFF	OFF
TELCOM GRP 1	AC1	AC1	AC1	AC1
TELCOM GRP 2	AC2	AC2	AC2	AC2
GLY PUMPS	2 AC1	1 AC1	1 AC1	1 AC1
SUIT COMPR 1	OFF	AC1	AC1	OFF
SUIT COMPR 2	OFF	OFF	OFF	OFF
cb SUIT COMPR AC1 ØA	close	close	close	close
cb SUIT COMPR AC1 ØB	close	close	close	close
cb SUIT COMPR AC1 ØC	close	close	close	close
cb SUIT COMPR AC2 ØA	close	close	close	close
cb SUIT COMPR AC2 ØB	close	close	close	close
cb SUIT COMPR AC2 ØC	close	close	close	close
cb GLY PUMPS AC1 ØA	close	close	close	close
cb GLY PUMPS AC1 ØB	close	close	close	close
cb GLY PUMPS AC1 ØC	close	close	close	close
cb GLY PUMPS AC2 ØA	close	close	close	close
cb GLY PUMPS AC2 ØB	close	close	close	close
cb GLY PUMPS AC2 ØC	close	close	close	close
PANEL 5				
MN BUS TIE BAT A/C	OFF	on (up)	on (up)	on (up)
MN BUS TIE BAT A/C	OFF	on (up)	on (up)	on (up)
FC1 PUMPS	AC1	AC1	AC1	AC1
FC2 PUMPS	AC2	AC2	AC2	AC2
FC3 PUMPS	AC2	AC2	AC2	AC2
SM RCS A ENG PKG HTRS	OFF	OFF	1	1
SM RCS C ENG PKG HTRS	OFF	OFF	1	1
SM RCS B ENG PKG HTRS	OFF	OFF	1	1
SM RCS D ENG PKG HTRS	OFF	OFF	1	1
SM RCS A QUAD HTRS	OFF	OFF	PRIM	PRIM
SM RCS C QUAD HTRS	OFF	OFF	PRIM	PRIM
SM RCS B QUAD HTRS	OFF	OFF	PRIM	PRIM
SM RCS D QUAD HTRS	OFF	OFF	PRIM	PRIM
SM RCS PSM 1 HTRS	OFF	OFF	PRIM	PRIM
SPS HTRS	OFF	OFF	PRIM	PRIM

PANELS 3 THRU 5

APOLLO-SOYUZ TEST PROJECT (ASTP)
OPERATIONS HANDBOOK

CSM CONTROL/INDICATOR CONFIGURATION				
NOMENCLATURE	PRIOR TO BACKUP CREW CABIN INGRESS	AT LIFTOFF	DOCKED TO SOYUZ	ENTRY PREPARATION
PANEL 5 (CONT)				
cb FLT/PL BUS MNA	close	close	close	close
cb FLT/PL BUS MNB	close	close	close	close
cb FLT/PL BUS BAT A	open	open	open	open
cb FLT/PL BUS BAT B	open	open	open	open
cb FLT/PL BUS BAT C	open	open	open	open
cb EPS SNSR SIG AC1	close	close	close	close
cb EPS SNSR SIG AC2	close	close	close	close
cb EPS SNSR SIG M1A	close	close	close	close
cb EPS SNSR SIG MNB	close	close	close	close
cb EPS SNSR PWR 1 BAT RLY	close	close	close	close
cb EPS SNSR PWR 2 BAT RLY	close	close	close	close
cb BAT RLY BUS BAT A	close	close	close	close
cb BAT RLY BUS BAT B	close	close	close	close
INTGL LTS	close	close	close	close
FLOOD LTS	on (cw)	as desired	as desired	as desired
	OFF (full dim	OFF (full dim	OFF (full dim	OFF (full dim
	or full brt)	or full brt)	or full brt)	or full brt)
	1	1	1	1
FLOOD DIM	OFF	OFF	OFF	OFF
FLOOD FIXED	ACL	ACL	ACL	ACL
BAT CHGR	close	close	close	close
cb BAT CHGR AC	close	close	close	close
cb BAT CHGR MNA	close	close	close	close
cb BAT CHGR MNB	close	close	close	close
cb BAT CHGR BAT A	close	close	close	close
cb BAT CHGR BAT B	close	close	close	close
cb BAT CHGR BAT C/EDS 2	close	close	close	close
cb INV CONT 1 BAT RLY	close	close	close	close
cb INV CONT 2 BAT RLY	close	close	close	close
cb INV CONT 3 BAT RLY	close	close	close	close
cb UTIL R/L STA MNA	close	close	close	close
cb SEC COOL ACL	close	close	close	close

APOLLO-SOYUZ TEST PROJECT (ASTP)
OPERATIONS HANDBOOK

cb SEC COOL AC2	close
cb SEC COOL HTR CONTR MNA	close
cb CAB FANS ØA AC1	close
cb CAB FANS ØB AC1	close
cb CAB FANS ØC AC1	close
cb H2O/URINE DUMP HTR MNA	open
cb H2O/URINE DUMP HTR MNB	open
cb H2O ACCUM MNA	close
cb H2O ACCUM MNB	close
cb PRIM RAD CONTR AC1	close
cb PRIM RAD CONTR AC2	close
cb PRIM RAD CONTR MNA	close
cb PRIM RAD CONTR MNB	close
cb C/W MNA	close
cb C/W MNB	close
cb TMRS MNA	close
cb TMRS MNB	close
cb G/N LTS AC1	close
cb G/N LTS AC2	close
cb G/N IMU MNA	close
cb G/N IMU MNB	close
cb G/N IMU HTR MNA	close
cb G/N IMU HTR MNB	close
cb G/N CMPTR MNA	close
cb G/N CMPTR MNB	close
cb G/N OPT MNA	close
cb G/N OPT MNB	close
cb INST MNA	close
cb INST MNB	close
cb EXP BUS MNA	close
cb EXP BUS MNB	close
cb EXP PWR A EXP BUS	open
cb EXP PWR B EXP BUS	open
cb EXP PWR C EXP BUS	open
cb SPS HTRS MNA	close
cb SPS HTRS MNB	close
cb UTIL LEB MNB	open

PANEL 5

APOLLO-SOYUZ TEST PROJECT (ASTP)
OPERATIONS HANDBOOK

CSM CONTROL/INDICATOR CONFIGURATION				
NOMENCLATURE	PRIOR TO BACKUP CREW CABIN INGRESS	AT LIFTOFF	DOCKED TO SOYUZ	ENTRY PREPARATION
PANEL 5 (CONT)				
cb IVA PWR MNB	open	open	open	open
cb IVA PWR MNA	open	open	open	open
cb 02 VAC ION PUMPS MNA	close	open	open	open
cb 02 VAC ION PUMPS MNB	close	open	open	open
PANEL 6				
MODE	INTERCOM/PTT	INTERCOM/PTT	INTERCOM/PTT	INTERCOM/PTT
VOX SENS tw	5 OFF	as req AUDIO/TONE	as req AUDIO	as req AUDIO/TONE
PWR	5	as req OFF	5 OFF	as req OFF
MASTER VOL tw	T/R	as desired OFF	as desired RMTE	as desired OFF
VHF FM/PAD COMM	5	as desired OFF	as desired incr	as desired decr
VHF FM/PAD COMM VOL tw	5	as desired OFF	as desired T/R	as desired T/R
CM/RMTE INTERCOM	decr	decr	incr	decr
CM/RMTE INTERCOM VOL tw	T/R	T/R	T/R	T/R
S BD	5	as req	5.3	as req
S BD VOL tw	T/R	T/R	5.3	T/R
VHF AM	5	as req	5	as req
VHF AM VOL tw	NORM	NORM	NORM	NORM
AUDIO CONT	OFF	on (up)	OFF	on (up)
SUIT PWR	OFF	on (up)	OFF	on (up)
PANEL 7				
EDS PWR	OFF	on (up)	OFF	OFF
TVC SERVO PWR 1	OFF	AC1/MNA	AC1/MNA	AC1/MNA
TVC SERVO PWR 2	OFF	AC2/MNB	AC2/MNB	AC2/MNB
FDAL/GPI PWR	OFF	BOTH	BOTH	BOTH
LOGIC 2/3 PWR	on (up)	on (up)	on (up)	on (up)
ELEC PWR	OFF	GDC/ECA	GDC/ECA	GDC/ECA

APOLLO-SOYUZ TEST PROJECT (ASTP)
OPERATIONS HANDBOOK

	OFF OFF WAI UP WARM UP partially OPEN (ccw)	AC1 AC2 ON ON partially OPEN (ccw)	AC1 AC2 ON ON close (cw)	AC1 AC2 ON ON close (cw)
SIG CONDR/DR BIAS PWR 1			AC1	
SIG CONDR/DR BIAS PWR 2			AC2	
BMAG 1 PWR		ON	ON	
BMAG 2 PWR		ON	ON	
DIRECT O2 VLV	partially OPEN (ccw)	partially OPEN (ccw)	close (cw)	close (cw)
PANEL 8				
cb SCS TVC AC1	close	close	close	close
cb SCS AC1	close	close	close	close
cb SCS AC2	close	close	close	close
AUTO RCS A/C ROLL A1	OFF	OFF	OFF	OFF
AUTO RCS A/C ROLL C1	OFF	OFF	OFF	OFF
AUTO RCS A/C ROLL A2	OFF	OFF	OFF	OFF
AUTO RCS A/C ROLL C2	OFF	OFF	OFF	OFF
AUTO RCS A/C ROLL B1	OFF	OFF	OFF	OFF
AUTO RCS B/D ROLL D1	OFF	OFF	OFF	OFF
AUTO RCS B/D ROLL B2	OFF	OFF	OFF	OFF
AUTO RCS B/D ROLL D2	OFF	OFF	OFF	OFF
AUTO RCS PITCH A3	OFF	OFF	OFF	OFF
AUTO RCS PITCH C3	OFF	OFF	OFF	OFF
AUTO RCS PITCH A4	OFF	OFF	OFF	OFF
AUTO RCS PITCH C4	OFF	OFF	OFF	OFF
AUTO RCS YAW B3	OFF	OFF	OFF	OFF
AUTO RCS YAW D3	OFF	OFF	OFF	OFF
AUTO RCS YAW B4	OFF	OFF	OFF	OFF
AUTO RCS YAW D4	OFF	OFF	OFF	OFF
cb SCS ECA/TVC AC2	close	close	close	close
cb SCS DIR ULL MNA	close	close	close	close
cb SCS DIR ULL MNB	close	close	close	close
cb SCS CONTR DIR 1 MNA	close	close	close	close
cb SCS CONTR DIR 1 MNB	close	close	close	close
cb SCS CONTR DIR 2 MNA	close	close	close	close
cb SCS CONTR DIR 2 MNB	close	close	close	close
cb SCS A/C ROLL MNA	close	close	close	close
cb SCS A/C ROLL MNB	close	close	close	close
cb SCS B/D ROLL MNA	close	close	close	close

PANELS 5 THRU 8

APOLLO-SOYUZ TEST PROJECT (ASTP)
OPERATIONS HANDBOOK

CSM CONTROL/INDICATOR CONFIGURATION				
NOMENCLATURE	PRIOR TO BACKUP CREW CABIN INGRESS	AT LIFTOFF	DOCKED TO SOYUZ	ENTRY PREPARATION
	PANEL 8 (CONT)			
cb SCS B/D ROLL MNB	close	close	close	close
cb SCS PITCH MNA	close	close	close	close
cb SCS PITCH MNB	close	close	close	close
cb SCS YAW MNA	close	close	open	close
cb SCS YAW MNB	close	close	close	close
NUMERICS LTS	as desired	as desired	as desired	as desired
FLOOD LTS	OFF (full dim or full BRT)	OFF (full dim or full BRT)	OFF (full dim or full BRT)	OFF (full dim or full BRT)
INTGL LTS	as desired	as desired	as desired	as desired
cb ORDEAL AC2	close	close	close	close
cb ORDEAL MNB	close	close	close	close
cb SCS CONTR AUTO MNA	close	close	close	close
cb SCS CONTR AUTO MNB	close	close	close	close
cb SCS LOGIC 1/2 MNA	close	close	open	close
cb SCS LOGIC 3/4 MNA	close	close	close	close
cb SCS LOGIC 1/4 MNB	close	close	open	close
cb SCS LOGIC 2/3 MNB	close	close	close	close
cb SCS SYS MNA	close	close	close	close
cb SCS SYS MNB	close	close	close	close
FLOOD DIM	1	1	1	1
FLOOD FIXED	OFF	OFF	OFF	OFF
FLOAT BAG 1 L	VENT (locked)	VENT (locked)	VENT (locked)	VENT (locked)
FLOAT BAG 2 R	VENT (locked)	VENT (locked)	VENT (locked)	VENT (locked)
FLOAT BAG 3 CTR	VENT (locked)	VENT (locked)	VENT (locked)	VENT (locked)
SECS LOGIC 1	OFF (locked)	on (up) (locked)	OFF (locked)	OFF (locked)
SECS LOGIC 2	OFF (locked)	on (up) (locked)	OFF (locked)	OFF (locked)
SECS PYRO A AFM	SAFE (locked)	on (up) (locked)	SAFE (locked)	SAFE (locked)

APOLLO-SOYUZ TEST PROJECT (ASTP)
OPERATIONS HANDBOOK

SECS PYRO B ARM	SAFE (locked)	on (up) (locked)	SAFE (locked)	SAFE (locked)
cb CM RCS 1 HTR MNA	open	open	open	open
cb CM RCS 2 HTR MNB	open	open	open	open
cb SM RCS PRIM A/C HTRS MNB	close	close	close	close
cb SM RCS PRIM B/D HTRS MNA	close	close	close	close
cb SM RCS SEC A/C HTRS MNA	close	close	close	close
cb SM RCS SEC B/D HTRS MNB	close	close	close	close
cb RCS PRPLNT ISOL MNA	close	close	close	close
cb RCS PRPLNT ISOL MNB	close	close	close	close
cb RCS LOGIC MNA	close	close	open	open
cb RCS LOGIC MNB	close	close	open	open
cb EMS MNA	close	close	close	close
cb EMS MNB	close	close	close	close
cb DOCK PROBE MNA	open	open	open	open
cb DOCK PROBE MNB	open	open	open	open
cb SPS GAUGING MNA	open	open	open	open
cb SPS GAUGING MNB	open	open	open	open
cb SPS GAUGING ACL	open	open	open	open
cb SPS GAUGING AC2	open	open	open	open
cb SPS He VLV MNA	close	close	close	close
cb SPS He VLV MNB	close	close	close	close
cb SPS PITCH 1 BAT A	oper	close	close	close
cb SPS PITCH 2 BAT B	close	close	close	close
cb SPS YAW 1 BAT A	open	close	close	close
cb SPS YAW 2 BAT B	close	close	close	close
cb SPS PILOT VLVS A MNA	close	close	close	close
cb SPS PILOT VLVS B MNB	close	close	close	close
cb FLOAT BAG 1 BAT A	open	open	open	open
cb FLOAT BAG 2 BAT B	open	open	open	open
cb FLOAT BAG 3 FLT/PL	open	open	open	open
cb SECS LOGIC A BAT A	open	close	close	close
cb SECS LOGIC B BAT B	oper	close	close	close
cb SECS ARM A BAT A	open	close	open	open
cb SECS ARM B BAT B	open	close	open	open
cb EDS 1 BAT A	close	close	open	open
cb EDS 2 BAT C	close	close	open	open

PANEL 8

APOLLO-SOYUZ TEST PROJECT (ASTP)
OPERATIONS HANDBOOK

CSM CONTROL/INDICATOR CONFIGURATION				
NOMENCLATURE	PRIOR TO BACKUP CREW CABIN INGRESS	AT LIFTOFF	DOCKED TO SOYUZ	ENTRY PREPARATION
PANEL 8 (CONT)				
cb EDS 3 BAT B	close	close	open	open
cb ELS/CM SM SEP BAT A	close	close	open	open
cb ELS/CM SM SEP BAT B	close	close	open	open
cb PL VENT FLT/PL	close	close	open	open
PANEL 9				
MODE	INTERCOM/PTT	INTERCOM/PTT	INTERCOM/PTT	INTERCOM/PTT
VOX SENS tw	5	as req	as req	as req
PWR	OFF	AUDIO/TONE	AUDIO	AUDIO/TONE
MASTER VOL tw	5	as req	5.0	as req
INTERCOM	T/R	T/R	OFF	T/R
INTERCOM VOL tw	5	as req	4.2	as req
VHF FM/PAD COMM	T/R	OFF	OFF	OFF
VHF FM/PAD COMM VOL tw	5	as desired	as desired	as desired
S BD	T/R	T/R	OFF	OFF
S BD VOL tw	5	as req	4.4	as req
VHF AM	T/R	T/R	OFF	T/R
VHF AM VOL tw	5	as req	5.4	as req
AUDIO CONT	NORM	NORM	NORM	NORM
SUIT PWR	OFF	on (up)	OFF	on (up)
VHF RNG	NORM	NORM	NORM	NORM

APOLLO-SOYUZ TEST PROJECT (ASTP)
OPERATIONS HANDBOOK

PANEL 10				
	INTERCOM/PTT	INTERCOM/PTT	INTERCOM/PTT	INTERCOM/PTT
MODE	5	as req	as req	as req
VOX SENS tw	OFF	AUDIO/TONE	AUDIO/TONE	AUDIO/TONE
PWR	5	as req	as desired	as req
MASTER VOL tw	T/R	OFF	OFF	OFF
VHF FM/PAD COMM	5	as desired	as desired	as desired
VHF FM/PAD COMM VOL tw	T/R	T/R	T/R	T/R
INTERCOM	5	as req	as desired	as req
INTERCOM VOL tw	T/R	T/R	T/R	T/R
S BD	5	as req	as desired	as req
S BD VOL tw	T/R	as req	as desired	as req
VHF AM	5	T/R	OFF	T/R
VHF AM VOL tw	5	as req	as desired	as req
AUDIO CONT	NORM	NORM	NORM	NORM
SUIT PWR	OFF	on (up)	OFF	on (up)
PANEL 12				
TUNL VENT vlv	OFF	DM/CM ΔP	DM/CM ΔP	OFF
PANEL 13				
FDAI 1	INRTL	INRTL	INRTL	INRTL
FLAI 2	INRTL	INRTL	INRTL	INRTL
EARTH/LUNAR	PWR OFF	PWR OFF	PWR OFF	EARTH
ALT SET cont	88 NM	88 NM	121 NM	121 NM
LIGHTING	OFF	OFF	OFF	OFF
MODE	HOLD/FAST	HOLD/FAST	HOLD/FAST	HOLD/FAST
SLEW	ctr	ctr	ctr	ctr
PANEL 15				
COAS PWR	OFF	OFF	OFF	OFF
UTIL PWR	OFF	OFF	OFF	OFF
PL BCN LT	off (ctr)	off (ctr)	off (ctr)	off (ctr)
DYE MARKER	off (down)	off (down)	off (down)	off (down)
PL VENT	(guarded)	(guarded)	(guarded)	(guarded)
	OFF	OFF	OFF	OFF

PANELS 8 THRU 15

APOLLO-SOYUZ TEST PROJECT (ASTP)
OPERATIONS HANDBOOK

CSM CONTROL/INDICATOR CONFIGURATION				
NOMENCLATURE	PRIOR TO BACKUP CREW CABIN INGRESS	AT LIFTOFF	DOCKED TO SOYUZ	ENTRY PREPARATION
PANEL 16				
S5 UTIL PWR	off (down) OFF	off (down) OFF	off (down) OFF	off (down) OFF
PANEL 98				
XMIT/ICOM POWER VOL tv SPEAKER/HEADSET	off (ctr) OFF as req as req	off (ctr) OFF as req HEADSET	off (ctr) ON as req SPEAKER	off (ctr) OFF as req HEADSET
PANEL 100				
UTIL PWR FLOOD DIM FLOOD FIXED G/N OPT PWR G/N IMU PWR G/N LTS NUMERICS LTS FLOOD LTS INTGL LTS	OFF 1 OFF OFF on (up) (guarded) ACL as desired OFF (full dim or full BRT) as desired	OFF 1 OFF OFF on (up) (guarded) ACL as desired OFF (full dim or full BRT) as desired	OFF 1 OFF OFF OFF OFF OFF as desired OFF (full dim or full BRT) as desired	OFF 1 OFF on (up) on (up) (guarded) ACL as desired ON as desired

APOLLO-SOYUZ TEST PROJECT (ASTP)
OPERATIONS HANDBOOK

PANEL 101			
SYS TEST (LH)	3	3	3
SYS TEST (RH)	B	B	B
CM RCS HTRS	OFF	OFF	OFF
WASTE H2O DUMP	OFF	HTR A	OFF
URINE DUMP	OFF	HTR A	OFF
PANEL 122			
OPT ZERO	ZERO	ZERO	ZERO
OPT TELTRUN	SLAVE TO SXT	SLAVE TO SXT	SLAVE TO SXT
OPT COUPLING	DIR	DIR	RSLV
OPT MODE	MAN	MAN	CMC
OPT SPEED	LO	LO	LO
COND LAMPS	ON	ON	ON
UP TLM	ACPT	ACPT	ACPT
PANEL 163			
GLY EVAP	NORM	NORM	NORM
PANEL 164			
S1 (Located behind closeout panel and will be set at panel closeout)	OFF	ON	ON
PANEL 165			
EPE COOLING vlv	COOL	COOL	COOL

PANELS 16 THRU 165

APOLLO-SOYUZ TEST PROJECT (ASTP)
OPERATIONS HANDBOOK

CSM CONTROL/INDICATOR CONFIGURATION				
NOMENCLATURE	PRIOR TO BACKUP CREW CABIN INGRESS	AT LIFTOFF	DOCKED TO SOYUZ	ENTRY PREPARATION
	PANEL 201			
C/W INPUT 1A	ENBL	ENBL	ENBL	ENBL
C/W INPUT 1B	ENBL	ENBL	ENBL	ENBL
C/W INPUT 1C	ENBL	ENBL	ENBL	ENBL
C/W INPUT 1D	ENBL	ENBL	ENBL	ENBL
C/W INPUT 2A	ENBL	ENBL	ENBL	ENBL
C/W INPUT 2B	ENBL	ENBL	ENBL	ENBL
C/W INPUT 2C	ENBL	ENBL	ENBL	ENBL
C/W INPUT 2D	ENBL	ENBL	ENBL	ENBL
C/W INPUT 3A	ENBL	ENBL	ENBL	ENBL
C/W INPUT 3B	ENBL	ENBL	ENBL	ENBL
C/W INPUT 3C	ENBL	ENBL	ENBL	ENBL
C/W INPUT 3D	ENBL	ENBL	ENBL	ENBL
C/W INPUT 4A	ENBL	ENBL	ENBL	ENBL
C/W INPUT 4B	ENBL	ENBL	ENBL	ENBL
C/W INPUT 4C	ENBL	ENBL	ENBL	ENBL
C/W INPUT 4D	ENBL	ENBL	ENBL	ENBL
C/W INPUT 5A	ENBL	ENBL	ENBL	ENBL
C/W INPUT 5B	ENBL	ENBL	ENBL	ENBL
C/W INPUT 5C	ENBL	ENBL	ENBL	ENBL
C/W INPUT 5D	ENBL	ENBL	ENBL	ENBL
C/W INPUT 6A	ENBL	ENBL	ENBL	ENBL
C/W INPUT 6B	ENBL	ENBL	ENBL	ENBL
C/W INPUT 6C	ENBL	ENBL	ENBL	ENBL
C/W INPUT 6D	ENBL	ENBL	ENBL	ENBL
C/W INPUT 7A	ENBL	ENBL	ENBL	ENBL
C/W INPUT 7C	ENBL	ENBL	ENBL	ENBL
C/W INPUT 7D	ENBL	ENBL	ENBL	ENBL
C/W INPUT 8A	ENBL	ENBL	ENBL	ENBL
C/W INPUT 8B	ENBL	ENBL	ENBL	ENBL
C/W INPUT 8C	ENBL	ENBL	ENBL	ENBL

APOLLO-SOYUZ TEST PROJECT (ASTP)
OPERATIONS HANDBOOK

C/W INPUT 8D	ENBL	ENBL	ENBL	ENBL	ENBL	ENBL	ENBL	ENBL	ENBL
C/W INPUT 9A	ENBL	ENBL	ENBL	ENBL	ENBL	ENBL	ENBL	ENBL	ENBL
C/W INPUT 9B	ENBL	ENBL	ENBL	ENBL	ENBL	ENBL	ENBL	ENBL	ENBL
C/W INPUT 9C	ENBL	ENBL	ENBL	ENBL	ENBL	ENBL	ENBL	ENBL	ENBL
C/W INPUT 9D	ENBL	ENBL	ENBL	ENBL	ENBL	ENBL	ENBL	ENBL	ENBL
C/W INPUT 10A	ENBL	ENBL	ENBL	ENBL	ENBL	ENBL	ENBL	ENBL	ENBL
C/W INPUT 10B	ENBL	ENBL	ENBL	ENBL	ENBL	ENBL	ENBL	ENBL	ENBL
C/W INPUT 10C	ENBL	ENBL	ENBL	ENBL	ENBL	ENBL	ENBL	ENBL	ENBL
C/W INPUT 10D	ENBL	ENBL	ENBL	ENBL	ENBL	ENBL	ENBL	ENBL	ENBL
C/W INPUT 11A	ENBL	ENBL	ENBL	ENBL	ENBL	ENBL	ENBL	ENBL	ENBL
C/W INPUT 11B	ENBL	ENBL	ENBL	ENBL	ENBL	ENBL	ENBL	ENBL	ENBL
C/W INPUT 11C	ENBL	ENBL	ENBL	ENBL	ENBL	ENBL	ENBL	ENBL	ENBL
C/W INPUT 11D	ENBL	ENBL	ENBL	ENBL	ENBL	ENBL	ENBL	ENBL	ENBL
PANEL 223									
R C/W TONE ADJUST	as desired	as desired	as desired	as desired	as desired	as desired	as desired	as desired	as desired
L C/W TONE ADJUST	as desired	as desired	as desired	as desired	as desired	as desired	as desired	as desired	as desired
CTR C/W TONE ADJUST	as desired	as desired	as desired	as desired	as desired	as desired	as desired	as desired	as desired
PANEL 225									
cb PCM TLM ac GRP 1	close	close	close	close	close	close	close	close	close
cb PCM TLM ac GRP 2	close	close	close	close	close	close	close	close	close
cb FLT BUS MNA	close	close	close	close	close	close	close	close	close
cb FLT BUS MNB	close	close	close	close	close	close	close	close	close
cb PMP PRIM FLT BUS	close	close	close	close	close	close	close	close	close
cb PMP AUX FLT BUS	close	close	close	close	close	close	close	close	close
cb VHF/CREW AUDIO L FLT/PL	close	close	close	close	close	close	close	close	close
cb VHF/CREW AUDIO CTR FLT/PL	close	close	close	close	close	close	close	close	close
cb VHF/CREW AUDIO R FLT/PL	close	close	close	close	close	close	close	close	close
cb UDL FLT BUS	close	close	close	close	close	close	close	close	close
cb S DB XMTR/DSE FLT BUS	close	close	close	close	close	close	close	close	close
cb S DB XMTR/DSE ac GRP 1	close	close	close	close	close	close	close	close	close
cb CTE MNA	close	close	close	close	close	close	close	close	close
cb CTE MNB	close	close	close	close	close	close	close	close	close
cb SIG CONDR FLT BUS	close	close	close	close	close	close	close	close	close

PANELS 201 THRU 225

APOLLO-SOYUZ TEST PROJECT (ASTP)
OPERATIONS HANDBOOK

CSM CONTROL/INDICATOR CONFIGURATION				
NOMENCLATURE	PRIOR TO BACKUP CREW CABIN INGRESS	AT LIFTOFF	DOCKED TO SOYUZ	ENTRY PREPARATION
PANEL 225 (CONT)				
cb S BD PWR AMPL 1 FLT BUS	close	close	close	close
cb S BD PWR AMPL 1 ac GRP 1	close	close	close	close
cb S BD PWR AMPL 2 FLT BUS	close	close	close	close
cb S BD PWR AMPL 2 ac GRP 2	close	close	close	close
PANEL 226				
cb FC 1 PUMPS AC	close	close	close	close
cb FC 1 REACS BAT TLY	open	close	close	close
cb FC 1 BUS CONT BAT RLY	close	close	close	close
cb FC 1 PURG MNA	close	close	close	close
cb FC 1 RAD BAT RLY	open	open	open	open
cb CRYO H2 HTR 1 MNA	close	close	close	close
cb CRYO H2 HTR 2 MNB	close	close	close	close
cb FC 2 PUMPS AC	close	close	close	close
cb FC 2 REACS BAT RLY	close	close	close	close
cb FC 2 BUS CONT BAT RLY	close	close	close	close
cb FC 2 PURG MNA	close	close	close	close
cb FC 2 RAD BAT RLY	open	open	open	open
cb CRYO 02 100 W HTR 1 MNA	close	close	close	close
cb CRYO 02 100 W HTR 2 MNB	close	close	close	close
cb FC 3 PUMPS AC	close	close	close	close
cb FC 3 REACS BAT RLY	open	close	close	close
cb FC 3 BUS CONT BAT RLY	close	close	close	close
cb FC 3 PURG MNB	close	close	close	close
cb FC 3 RAD BAT RLY	open	open	open	open
cb CRYO 02 50 W HTR 1 MNA	close	close	close	close
cb CRYO 02 50 W HTR 2 MNB	close	close	close	close
cb CRYO CIR TKI AC1 ØA	close	close	close	close
cb CRYO CIR TKI AC1 ØB	close	close	close	close

APOLLO-SOYUZ TEST PROJECT (ASTP)
OPERATIONS HANDBOOK

PANEL 227				PANEL 229			
SCI	INST	PWR	OFF	OFF	OFF	OFF	OFF
cb	CRYO	CIR TK1 AC1 ØC/SCE	close	close	close	close	close
cb	CRYO	CIR TK2 AC2 ØA	close	close	close	close	close
cb	CRYO	CIR TK2 AC2 ØB	close	close	close	close	close
cb	CRYO	CIR TK2 AC2 ØC/SCE	close	close	close	close	close
cb	COAS/TUNL	LTG MNA	close	open	close	close	close
cb	COAS/TUNL	LTG MNB	close	close	close	close	close
cb	FLOOD	LTG MNA	close	close	close	close	close
cb	FLOOD	LTG MNB	close	close	close	close	close
cb	FLOOD	LTG FLT/PL	close	close	close	close	close
cb	NUM/INTGL	LTG LEB AC2	close	close	close	close	close
cb	NUM/INTGL	LTG L MDC AC1	close	close	close	close	close
cb	NUM/INTGL	LTG R MDC AC1	close	close	close	close	close
cb	RUN	LTG AC1	close	close	close	close	close
cb	RUN	LTG AC2	close	close	close	close	close
cb	EPS	GRP 1 MNA	close	close	close	close	close
cb	EPS	GRP 1 MNB	close	close	close	close	close
cb	EPS	GRP 2 MNA	close	close	close	close	close
cb	EPS	GRP 2 MNB	close	close	close	close	close
cb	EPS	GRP 3 MNA	close	close	close	close	close
cb	EPS	GRP 3 MNB	close	close	close	close	close
cb	EPS	GRP 4 MNA	close	close	close	close	close
cb	EPS	GRP 4 MNB	close	close	close	close	close
cb	EPS	GRP 5 MNA	close	close	close	close	close
cb	EPS	GRP 5 MNB	close	close	close	close	close
cb	EPS	BAT BUS A	close	close	close	close	close
cb	EPS	BAT BUS B	close	close	close	close	close
cb	PYRO	BUS A PYRO BAT A	close	close	close	close	close
cb	PYRO	BUS A BAT BUS A	open	open	open	open	open
cb	PYRO	BUS B PYRO BAT B	close	close	close	close	close
cb	PYRO	BUS B BAT BUS B	open	open	open	open	open
cb	MN	REL PYRO A	open	open	open	open	open
cb	MN	REL PYRO B	open	open	open	open	open

PANELS 225 THRU 229

APOLLO-SOYUZ TEST PROJECT (ASTP)
OPERATIONS HANDBOOK

CSM CONTROL/INDICATOR CONFIGURATION				
NOMENCLATURE	PRIOR TO BACKUP CREW CABIN INGRESS	AT LIFTOFF	DOCKED TO SOYUZ	ENTRY PREPARATION
PANEL 230				
cb UVA EXP MNB	open	open	open	open
cb UVA COVER MNB	open	open	open	open
UVA PWR	OFF	OFF	OFF	OFF
UVA LAMPS	OFF	OFF	OFF	OFF
UVA COVER	ctr	ctr	as req	ctr
ETE PWR	OFF	OFF	OFF	OFF
PANEL 250				
cb INV PWR 1 MNA	close	close	close	close
cb INV PWR 2 MNB	close	close	close	close
cb INV PWR 3 MNA	close	close	close	close
cb INV PWR 3 MNB	close	close	close	close
cb MN BUS INTERCONNECT MNA	open	open	open	open
cb MN BUS INTERCONNECT MNB	open	open	open	open
PANEL 251				
OVBD DRAIN vlv	OFF	OFF	OFF	OFF
PANEL 252				
BAT VENT vlv	VENT	VENT	VENT	VENT
WASTE STOW VENT vlv	CLOSE	CLOSE	CLOSE	CLOSE

APOLLO-SOYUZ TEST PROJECT (ASTP)
OPERATIONS HANDBOOK

PANEL 274			
cb ELECTROPHORESIS MNA	close	close	open
cb ELECTROPHORESIS MNB	close	close	open
cb DM FURNACE/CRYSTAL	open	as req	open
GROWTH 1 - MNA	open	as req	open
cb DM FURNACE/CRYSTAL	open	as req	open
GROWTH 2 - MNA	open	as req	open
cb ETE AC2 0A	open	open	open
cb ETE AC2 0B	open	open	open
cb ETE AC2 0C	close	close	close
cb UV MNB	close	close	open
cb VIDEO RCDR MNA	close	close	open
cb VIDEO CAMR/MON MNA	close	close	open
cb DS A IND LOGIC MNA	open	close	open
cb DS A IND PWR AC1	open	close	open
cb DS A CONTROL BAT A	open	open	open
cb DS A MOTORS AC1 0A	open	open	open
cb DS A MOTORS AC1 0B	open	open	open
cb DS A MOTORS AC1 0C	open	open	open
cb DM POWER MNA	open	close	open
cb DM POWER MNB	open	close	open
TUNL LTS	OFF	OFF	OFF
EXT RUN LTS	OFF	OFF	OFF
EXT RNDZ LTS	OFF	OFF	OFF
cb DS B IND LOGIC MNB	open	close	open
cb DS B IND PWR AC2	open	close	open
cb DS B CONTROL BAT B	open	open	open
cb DS B MOTORS AC2 0A	open	open	open
cb DS B MOTORS AC2 0B	open	open	open
cb DS B MOTORS AC2 0C	open	open	open
cb SIVB/DM SEP PYRO A	close	open	open
cb SIVB/DM SEP PYRO B	close	open	open

PANELS 230 THRU 274

APOLLO-SOYUZ TEST PROJECT (ASTP)
OPERATIONS HANDBOOK

CSM CONTROL/INDICATOR CONFIGURATION				
NOMENCLATURE	PRIOR TO BACKUP CREW CABIN INGRESS	AT LIFTOFF	DOCKED TO SOYUZ	ENTRY PREPARATION
	PANEL 275			
cb MNA BAT BUS A	close	close	close	close
cb MNA BAT C	open	open	open	close
cb MNB BAT C	open	open	open	close
cb MNB BAT BUS B	close	close	close	close
cb BAT BUS A BAT A	close	close	close	close
cb BAT BUS A MNA	open	open	open	open
cb BAT BUS A BAT C	open	open	open	open
cb BAT BUS A PYRO BAT A	open	open	open	open
cb BAT BUS B BAT B	close	close	close	close
cb BAT BUS B MNB	open	open	open	open
cb BAT BUS B BAT C	open	open	open	open
cb BAT BUS B PYRO BAT B	open	open	open	open
PANEL 276				
CB1 INST PMR CONT	close	close	close	close
CB2 INST PMR CONT	close	close	close	close
CB3 INST PMR CONT	close	close	close	close
CB4 INST PMR CONT	close	close	close	close
PANEL 278				
cb UPR SYS COMPR 1	open	open	open	open
cb UPR SYS COMPR 2	open	open	open	open
cb DOCK RING SEP BAT A	close	open	open	open
cb DOCK RING SEP BAT B	close	open	open	open
PANEL 300				
rh SUIT FLOW vlv	FULL FLOW	FULL FLOW	FULL FLOW	FULL FLOW

APOLLO-SOYUZ TEST PROJECT (ASTP)
OPERATIONS HANDBOOK

PANEL 301			
lh SUIT FLOW vlv	FULL FLOW	FULL FLOW	FULL FLOW
PANEL 302			
ctr SUIT FLOW vlv	FULL FLOW	FULL FLOW	FULL FLOW
PANEL 303			
PRIM CAB TEMP vlv	COLD (cw) MAX COOL (CW)	COLD (cw) MAX COOL (CW)	HOT (ccw) mid range
SEC CAB TEMP vlv			
PANEL 304			
DRINK H2O SUP vlv	OFF (cw) push lock lock closed	OFF (cw) push lock lock closed	OFF (cw) push lock lock closed
H2O gun probe safety			
H2O gun probe fire extg vlv			
PANEL 305			
FOOD PREP COLD H2O vlv	rel	rel	rel
FOOD PREP HOT H2O vlv	rel	rel	rel
PANEL 306			
MSN TMR	START UP (ctr)	START UP (ctr)	START UP (ctr)
EVNT TMR RSET	ctr	ctr	ctr
EVNT TMR START	ctr	ctr	ctr
EVNT TMR MIN	ctr	ctr	ctr
EVNT TMR SEC	ctr	ctr	ctr
MSN TMR HRS	ctr	ctr	ctr
MSN TMR MIN	ctr	ctr	ctr
MSN TMR SEC	ctr	ctr	ctr

PANELS 275 THRU 306

APOLLO-SOYUZ TEST PROJECT (ASTP)
OPERATIONS HANDBOOK

CSM CONTROL/INDICATOR CONFIGURATION				
NOMENCLATURE	PRIOR TO BACKUP CREW CABIN INGRESS	AT LIFTOFF	DOCKED TO SOYUZ	ENTRY PREPARATION
rh CAB PRESS RELF vlv	BOOST/ENTR	BOOST/ENTR	NORM	NORM
lh CAB PRESS RELF vlv	BOOST/ENTR	BOOST/ENTR	NORM	NORM
PRIM GLY TO RAD	NORM (in)	BYP (pull)	NORM (in)	NORM (in)
PANEL 326				
REPRESS PKG O2 vlv	OFF	ON	OFF	ON
SM O2 SUP vlv	ON	ON	ON	ON
SRG TK O2 vlv	ON	ON	ON	ON
GLY RSVR IN vlv	OPEN	OPEN	CLOSE	CLOSE
GLY RSVR BYP vlv	CLOSE	CLOSE	OPEN	OPEN
GLY RSVR OUT vlv	OPEN	OPEN	CLOSE	CLOSE
PANEL 350				
CO2 CSTR DIVERT vlv	ctr	ctr	ctr	ctr
PANEL 351				
MN REG A	OPEN	OPEN	OPEN	OPEN
MN REG B	OPEN	OPEN	OPEN	OPEN
H2O/GLY TK REG sel	BOTH	BOTH	BOTH	BOTH
H2O/GLY TK RELF sel	BOTH	BOTH	BOTH	BOTH
EMER CAB PRESS sel	OFF	OFF	BOTH	BOTH
CAB REPRESS vlv	OFF (ccw)	OFF (ccw)	OFF (ccw)	OFF (ccw)
PANEL 352				
WASTE TK SERV vlv	CLOSE	CLOSE	CLOSE	CLOSE
PRESS RELF sel	RELF	RELF	RELF	RELF
POT TK IN vlv	CLOSE	εs req	OPEN	OPEN
WASTE TK IN vlv	AUTO	AUTO	AUTO	AUTO

APOLLO-SOYUZ TEST PROJECT (ASTP)
OPERATIONS HANDBOOK

PANEL 375			
O2 SRG TK RELF vlv	OPEN (cw)	OPEN (cw)	OPEN (cw)
PANEL 376			
PLVC sw	NORM	NORM	NORM
PANEL 377			
GLY TO RAD SEC vlv	BYP	BYP	BYP
PANEL 378			
PRIM GLY ACCUM vlv	open (ccw)	open (ccw)	open (ccw)
PANEL 379			
PRIM ACCUM FILL vlv	OFF	OFF	OFF
PANEL 380			
DEMAND REG sel	BOTH	BOTH	BOTH
SUIT TEST vlv	OFF	OFF	OFF
SUIT RETURN vlv	close (push)	close (push)	open (pull)
PANEL 382			
SUIT FLOW RELF	OFF	OFF	OFF
GLY EVAP IN TEMP vlv	MIN (ccw) (push)	MIN (ccw) (push)	MAX (cw) (push)
SUIT HT EXCH SEC GLY	FLOW	FLOW	FLOW
SEC EVAP H2O CONT	AUTO	AUTO	AUTO
PRIM EVAP H2O CONT	AUTO	AUTO	AUTO
H2O ACCUM 1	RMTE	RMTE	RMTE
H2O ACCUM 2	RMTE	RMTE	RMTE

PANELS 325 THRU 382

APOLLO-SOYUZ TEST PROJECT (ASTP)
OPERATIONS HANDBOOK

CSM CONTROL/INDICATOR CONFIGURATION					
NOMENCLATURE	PRIOR TO BACKUP CREW CABIN INGRESS	AT LIFTOFF	POWER DOWN (FLIGHT)	QUIESCENT MODE (DOCKING)	AT CSM/SWS SEPARATION
PANEL 400					
TELEMETRY PWR	OFF	OFF	ON	OFF	
INTRLVR PWR	OFF	OFF	CN	OFF	
VTR PWR	OFF	OFF	ON	OFF	
HEADWHEEL DR MOT	ctr	ctr	as req	ctr	
TAPE MODE	ctr	ctr	as req	ctr	
TAPE DRIVE	ctr	ctr	as req	ctr	
TAPE HEAD CLEAN	NORM	NORM	NORM	NORM	
LAMP TEST	STATUS	STATUS	STATUS	STATUS	
PANEL 426					
VIDEO PWR	OFF	OFF	as req	as req	
VIDEO SOURCE	CM	CM	as req	as req	
VIDEO TV MODE	PLAYBACK	PLAYBACK	as req	as req	
PANEL 600					
EMER O2 VLV	CLOSE	CLOSE	CLOSE	CLOSE	
PANEL 601					
REPRESS O2 VLV	CLOSE (guarded)	CLOSE (guarded)	CLOSE (guarded)	CLOSE (guarded)	
PANEL 602					
REPRESS O2 RELF VLV	OPEN (cw)	OPEN (cw)	OPEN (cw)	OPEN (cw)	
PANEL 603					
I/A STA O2 SUP	OFF	OFF	OFF	OFF	

APOLLO-SOYUZ TEST PROJECT (ASTP)
OPERATIONS HANDBOOK

PANEL 604				
I/A PWR	OFF	OFF	OFF	OFF
FWD HATCH				
PRESS EQUAL vlv Actr handle sel Actr handle rel	CLOSE stowed locked	CLOSE stowed locked	OPEN stowed locked	CLOSE stowed locked
SIDE HATCH				
CAB PRESS DUMP vlv Gearbox sel Actr handle sel BPC jett knob	close (cw) LATCH L (latch) 180° from BPC JETT decal	close (cw) LATCH U (unlatch) Arrow on knob pointing to BPC JETT decal	close (cw) LATCH L (latch) 180° from BPC JETT decal	close (cw) LATCH L (latch) 180° from BPC JETT decal
Lockpin rel knob GN2 vlv handle	UNLOCK neutral	LOCK push (outboard)	UNLOCK neutral	UNLOCK neutral
Lockpin ind	flush	flush	flush	flush

PANELS 400 THRU 604

APOLLO-SOYUZ TEST PROJECT (ASTP)
OPERATIONS HANDBOOK

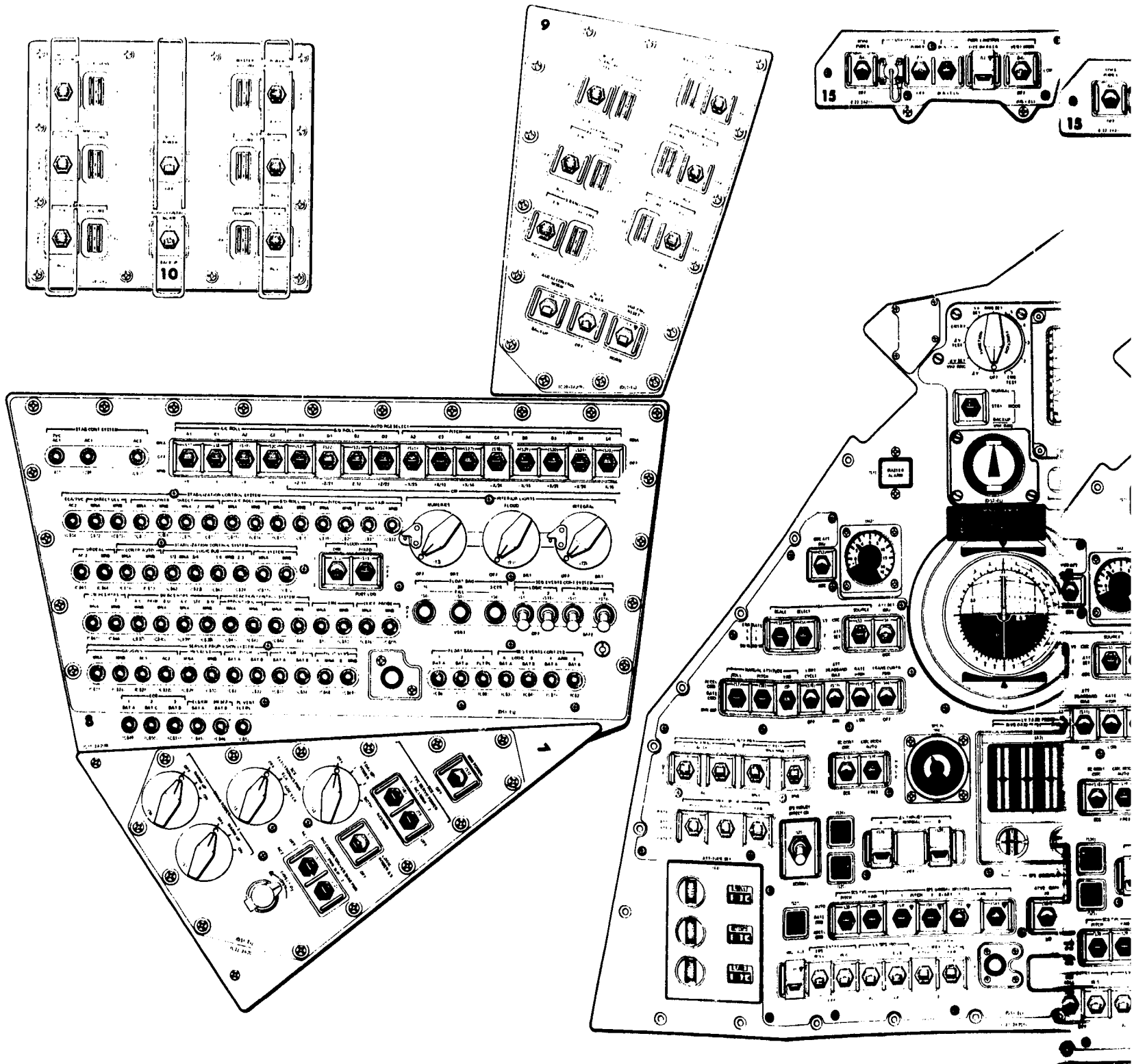
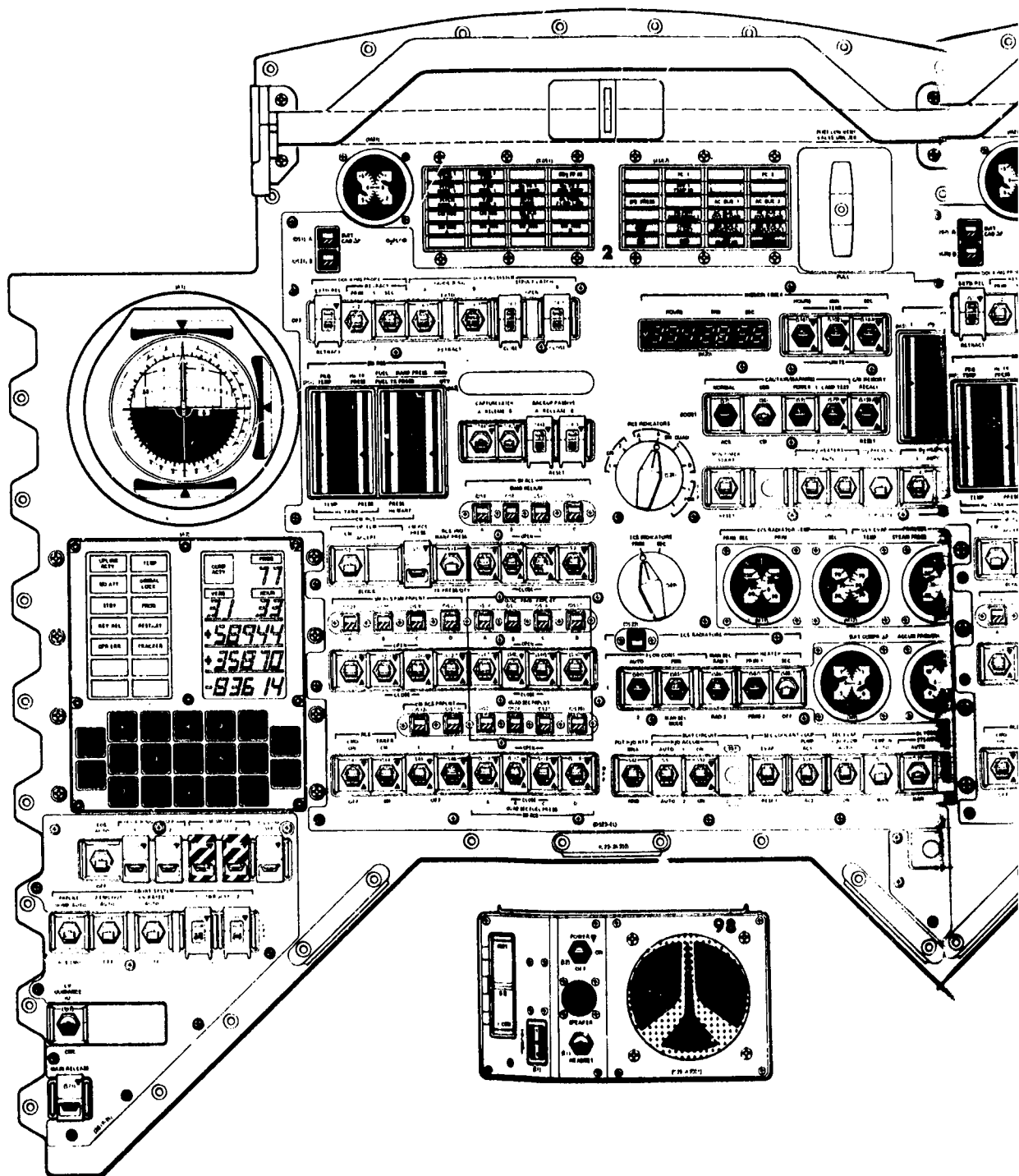
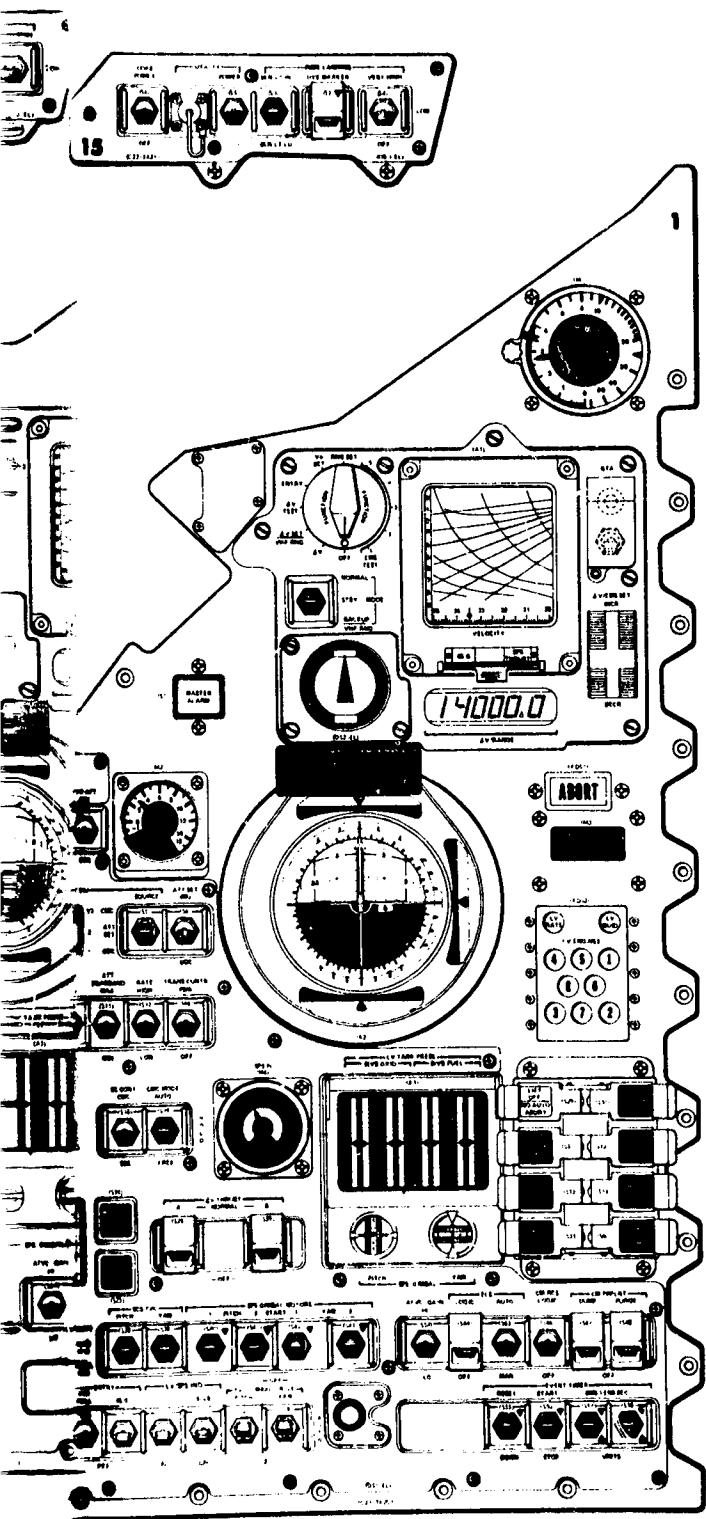
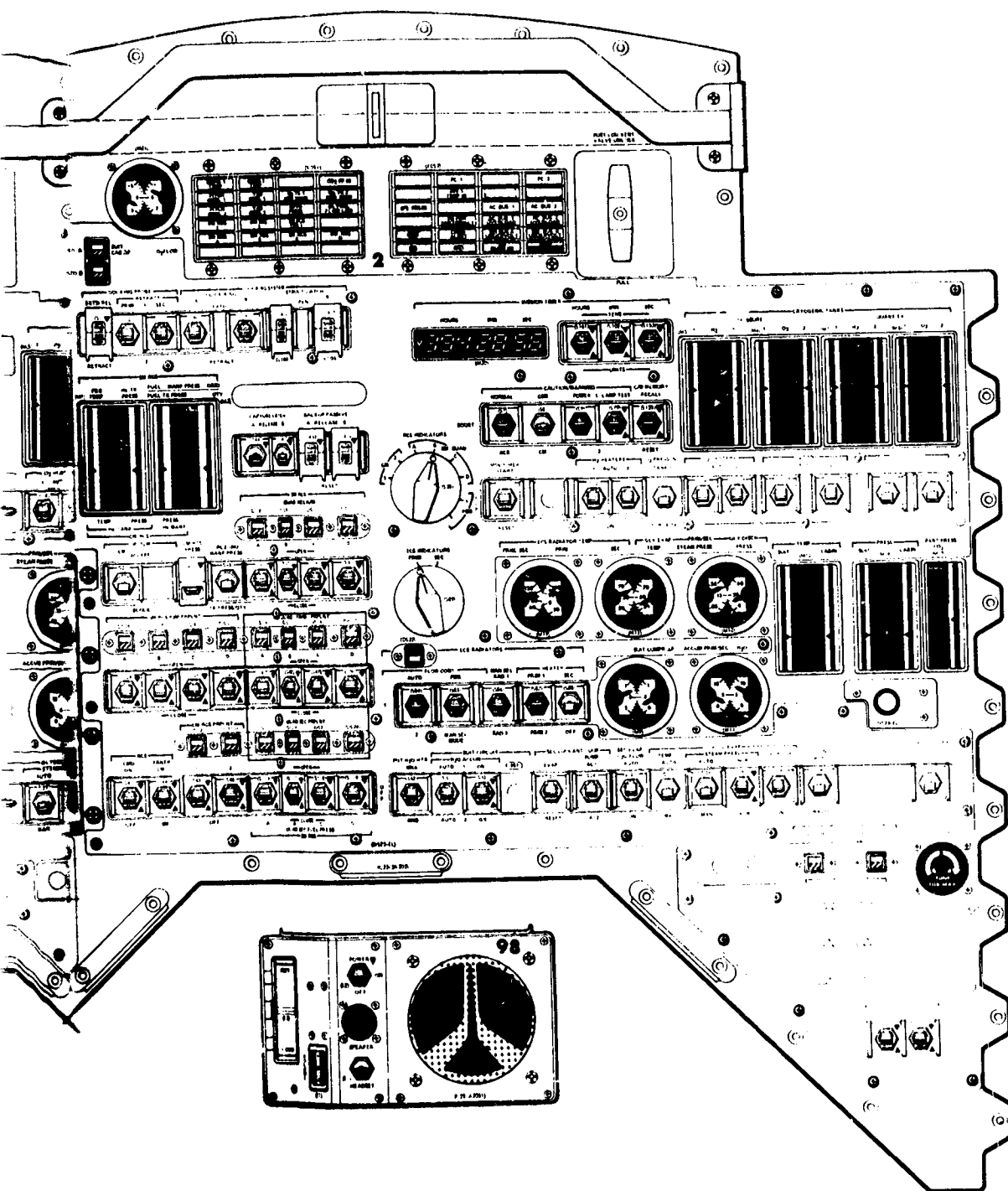

Figure A-1. Crew Displays and Controls (Sheet 1 of 5)

WOLDCUT FRAME





FOLDOUT FRAME

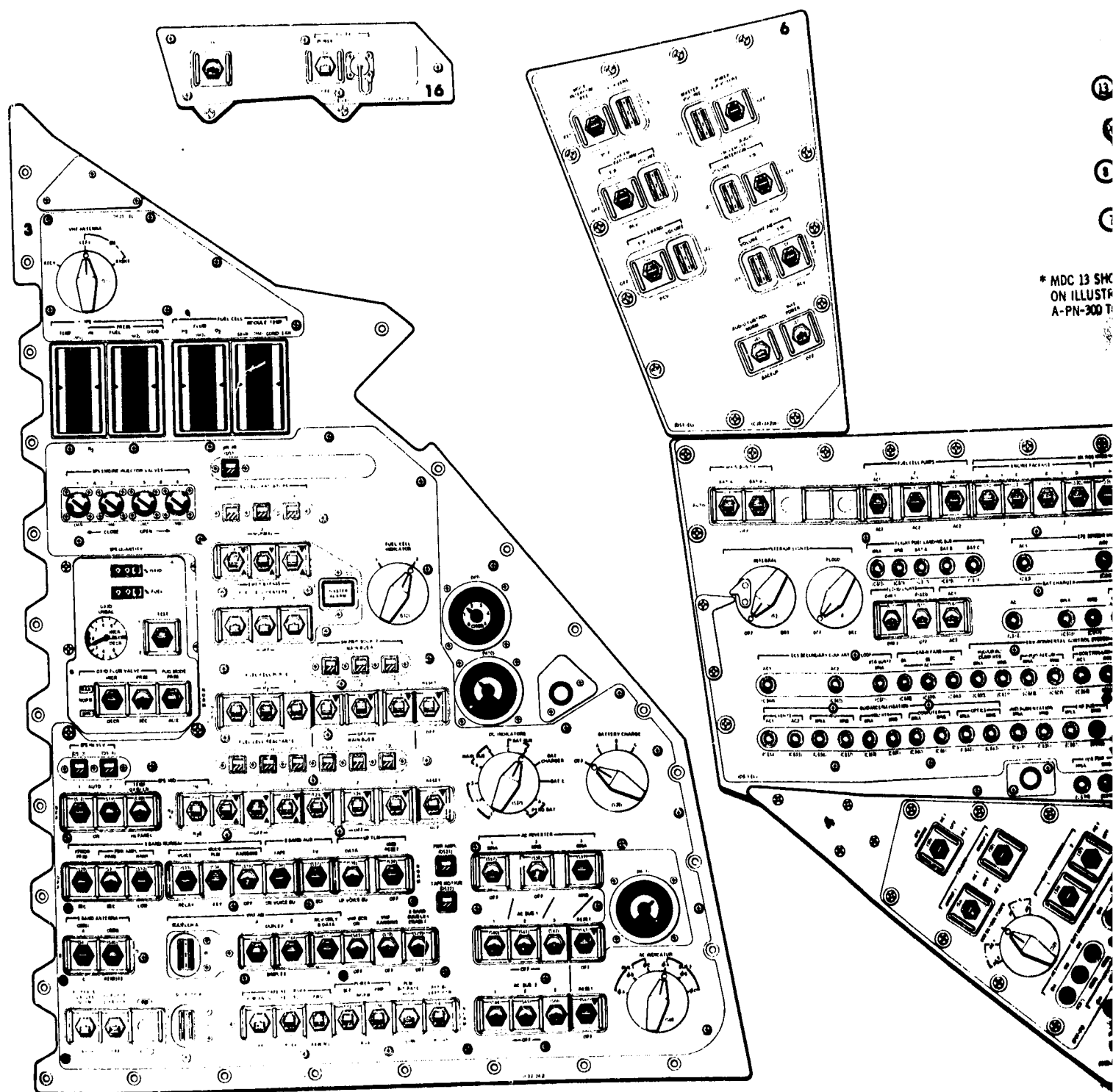

* MDC 13 SHC
ON ILLUSTR
A-PN-300 T

Figure A-1. Crew Display

Basic Date 15 July 1974 Change

APOLLO-SOYUZ TEST PROJECT (ASTP)
OPERATIONS HANDBOOK

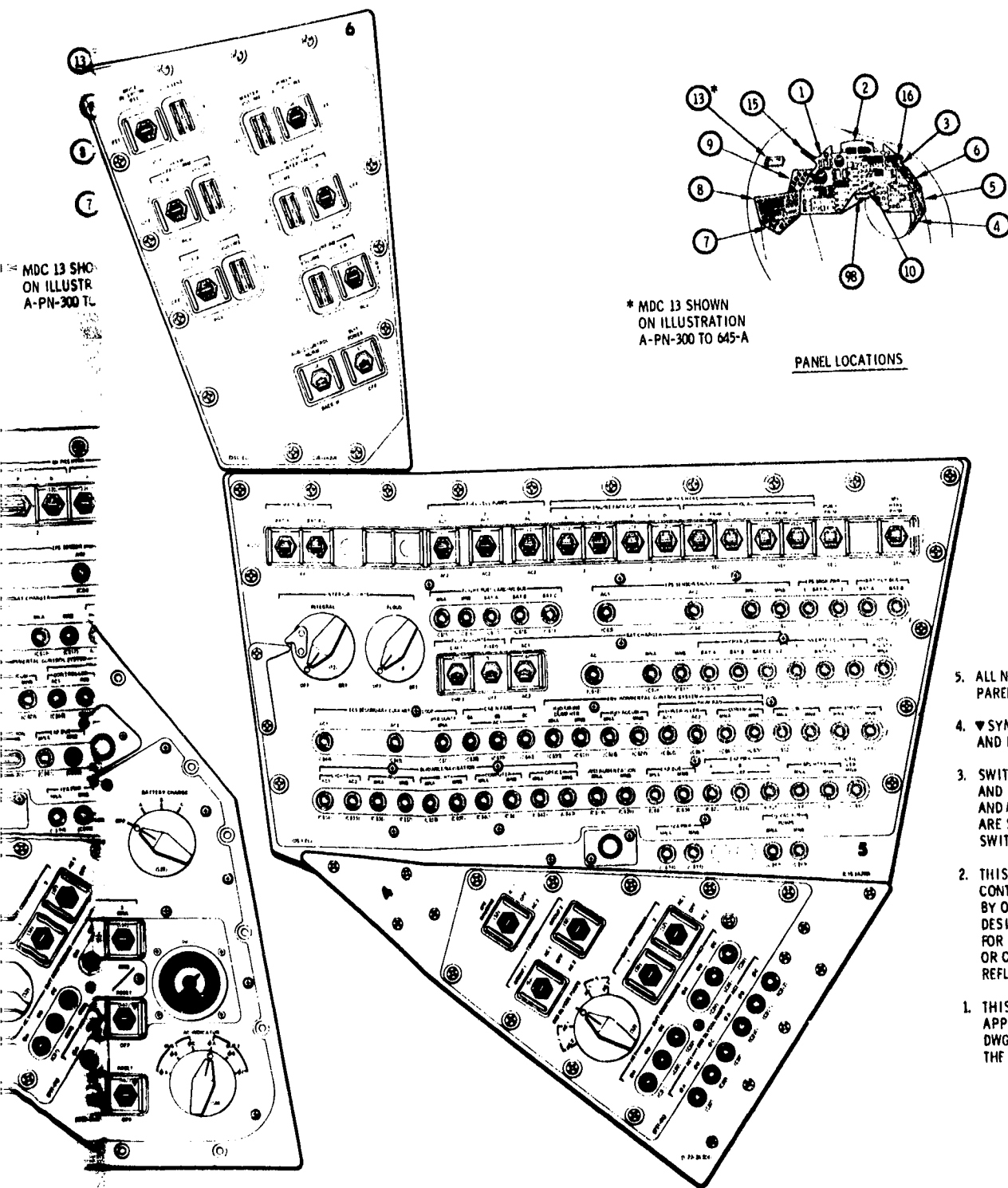

5. ALL NUMBERS AND LETTERS ENCLOSED WITH PARENTHESIS DO NOT APPEAR ON PANELS.
4. ▼ SYMBOL DENOTES MOMENTARY SWITCH POSITION AND DOES NOT APPEAR ON PANELS.
3. SWITCH POSITIONS ARE SHOWN FOR CONVENIENCE ONLY AND DO NOT NECESSARILY REFLECT OPERATING MODES AND/OR MISSION PHASES. TWO POSITION SWITCHES ARE SHOWN IN THE DOWN POSITION. THREE POSITION SWITCHES ARE SHOWN IN CENTER POSITION.
2. THIS IS AN ARRANGEMENT AND NOMENCLATURE CONTROL DWG FOR DESIGN REQUIREMENTS AND FOR USE BY OTHER DEPTS AS A GUIDE. ONLY RELEASED DESIGN DRAWINGS AND DOCUMENTS SHALL BE USED FOR MFG, MOCKUP, SIMULATOR, EVALUATOR, TRAINER OR CENTRIFUGE PANELS WHICH ARE INTENDED TO REFLECT CURRENT DESIGN.
1. THIS DWG REFLECTS A CONFIGURATION AS DEFINED BY APPLICABLE SCD'S, ASSEMBLY DWGS AND MARKING DWGS AS OF THE DATE OF RELEASE WITH RESPECT TO THE AFFECTED VEHICLES.

ASTP-MDC 1 TO 98-119A

CSM LOGISTICS TRAINING

Figure A-1. Crew Displays and Controls (Sheet 2 of 5)

APOLLO-SOYUZ TEST PROJECT (ASTP)
OPERATIONS HANDBOOK

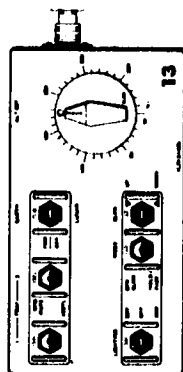
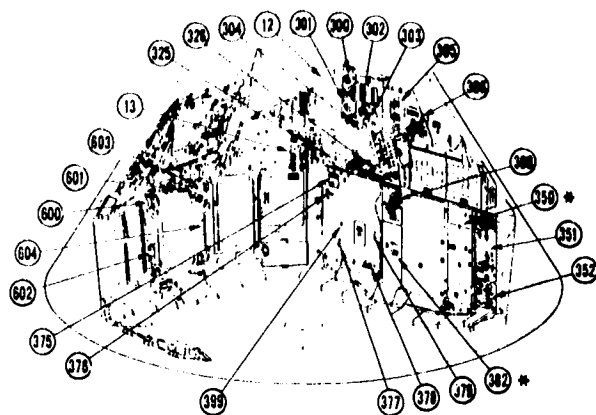

MDC (REAR-TUNNEL)

REAR-TUNNEL)

LEFT HAND INTERMEDIATE
EQUIPMENT BAY (LHIEB)

LEFT INTERMEDIATE
EQUIPMENT BAY (LHIEB)

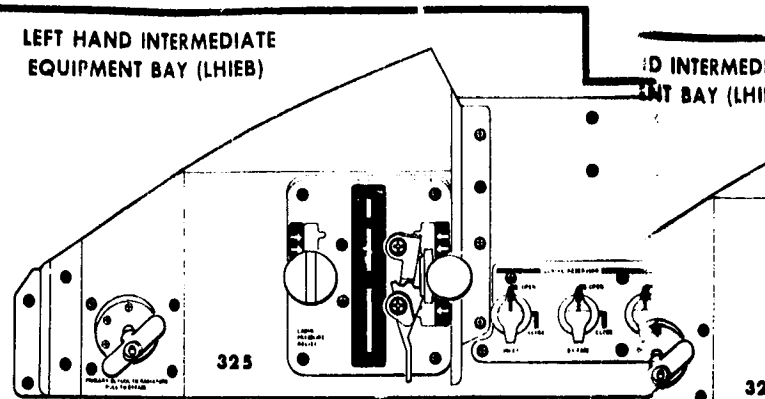

(GIRTH SHELF)

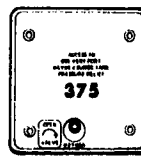
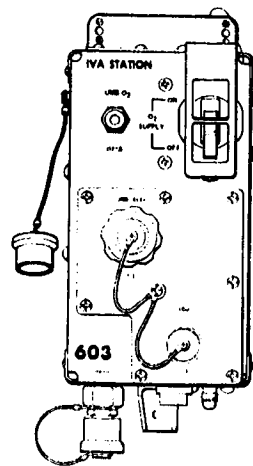
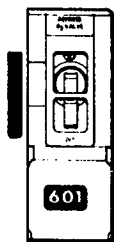
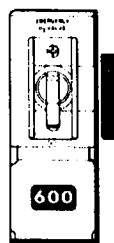

LEFT HAND EQUIPMENT BAY (LHIEB)

UPPER EQUIPMENT BAY (UEB)



NOTES:

1. ALL NUMBER AND LETTERS ENCLOSED WITH PARENTHESIS DO NOT APPEAR ON PANELS.
2. ▼ SYMBOL DENOTES MOMENTARY SWITCH POSITION AND DOES NOT APPEAR ON PANELS.
3. SWITCH POSITIONS ARE SHOWN FOR CONVENIENCE ONLY AND DO NOT NECESSARILY REFLECT OPERATING MODES AND/OR MISSION PHASES. TWO POSITION SWITCHES ARE SHOWN IN THE DOWN POSITION. THREE POSITION SWITCHES ARE SHOWN IN CENTER POSITION.

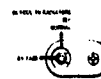
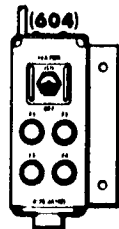

CONTROLS AND DISPLAYS
PANELS 300 TO 645
LHIEB, LHIEB, LHIEB, LHIEB

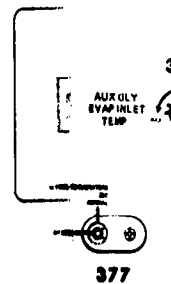

CONTROLS AND
PANELS 300
LHIEB, LHIEB, LHIEB

JULY 1974

FOLDOUT FRAME

Figure A-1. Crew Displays and Controls (Sheet 3 of 5)

AR-TUNNEL)

INTERMEDIATE
EQUIPMENT BAY (LHIEB)



325

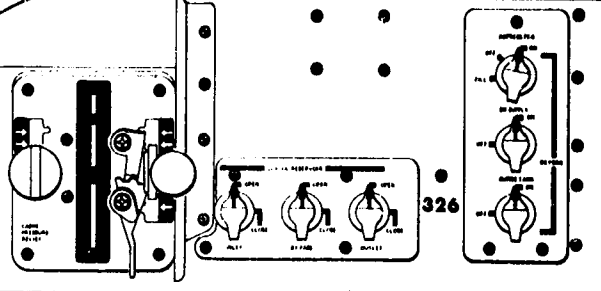

326

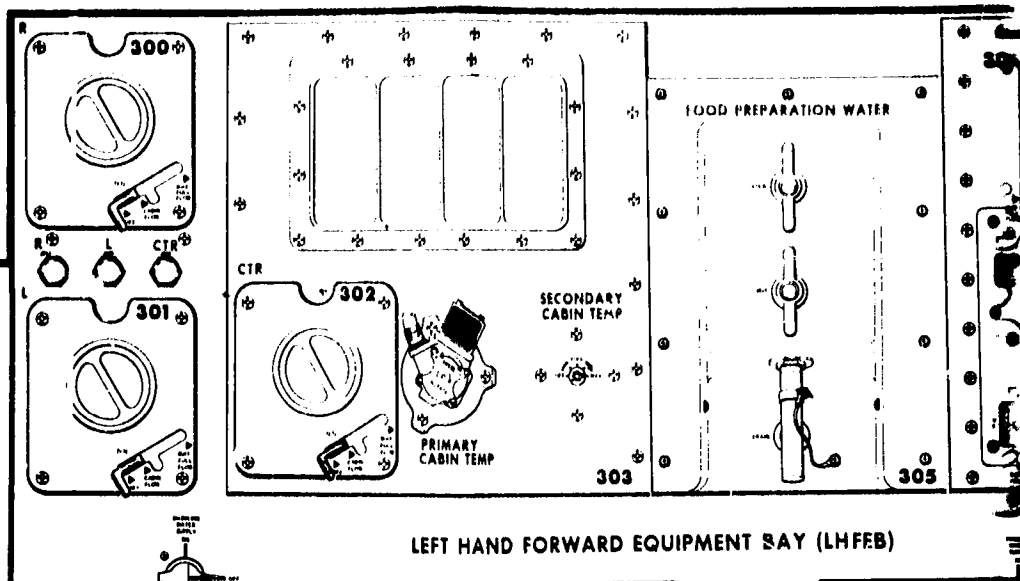

LEFT HAND FORWARD EQUIPMENT BAY (LHFEB)

(GIRTH SHELF)

LEFT HAND EQUIPMENT BAY (LHEB)

ME

399

AUXILIARY
EVAPORATOR
TEMP

379

FOR O2
TEMP

377

CONTROLS AND DISPLAYS

PANELS 300 TO 645

LHEB, LHIEB, LHFEB, UEB

378

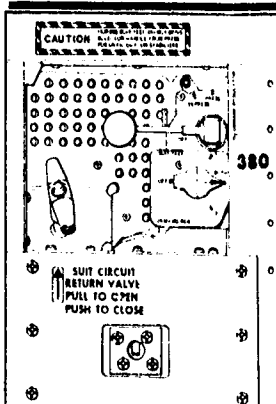

380

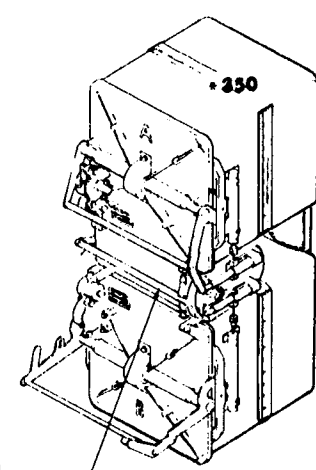

CO2 CANISTER
DIVERTER VALVE

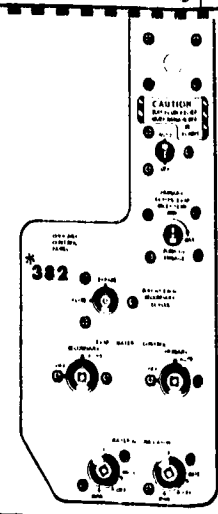

382

* CO2 CANISTER DIVERTER VALVE ASSEMBLY (380)
AND COOLANT CONTROL PANEL (382) LOCATED
BEHIND ATTENUATION PANELS.

5)

(119) A-39/A-40 FOLDOUT FRAME

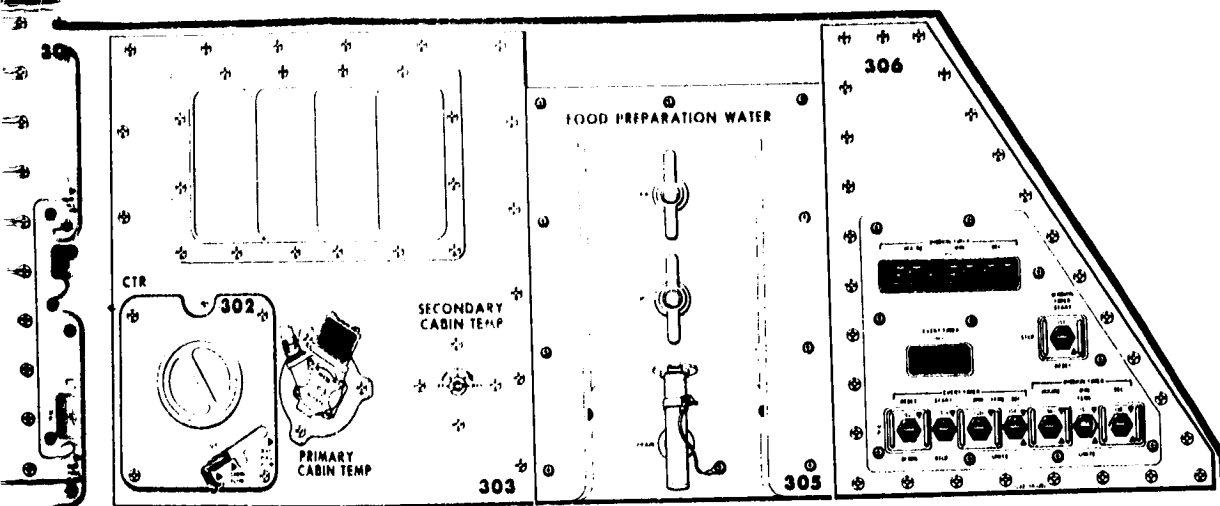

LEFT HAND FORWARD EQUIPMENT BAY (LHFEB)

(GIRTH SHELF)

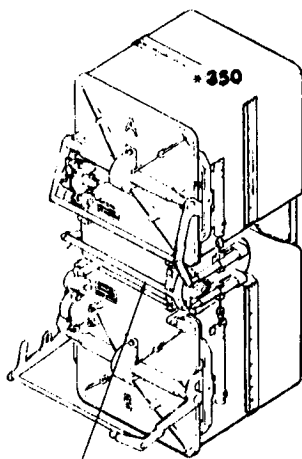
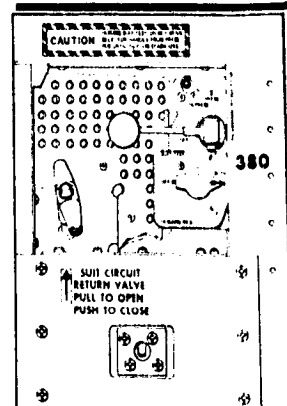

CO₂ CANISTER DIVERTER VALVE

* CO₂ CANISTER DIVERTER VALVE ASSEMBLY (350) AND COOLANT CONTROL PANEL (382) LOCATED BEHIND ATTENUATION PANELS..

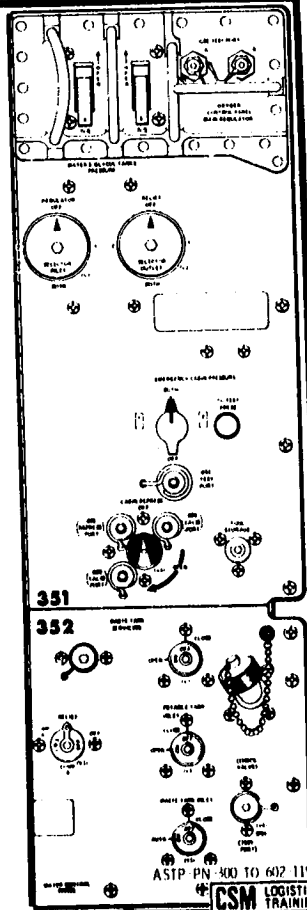

EQUIPMENT FRAME

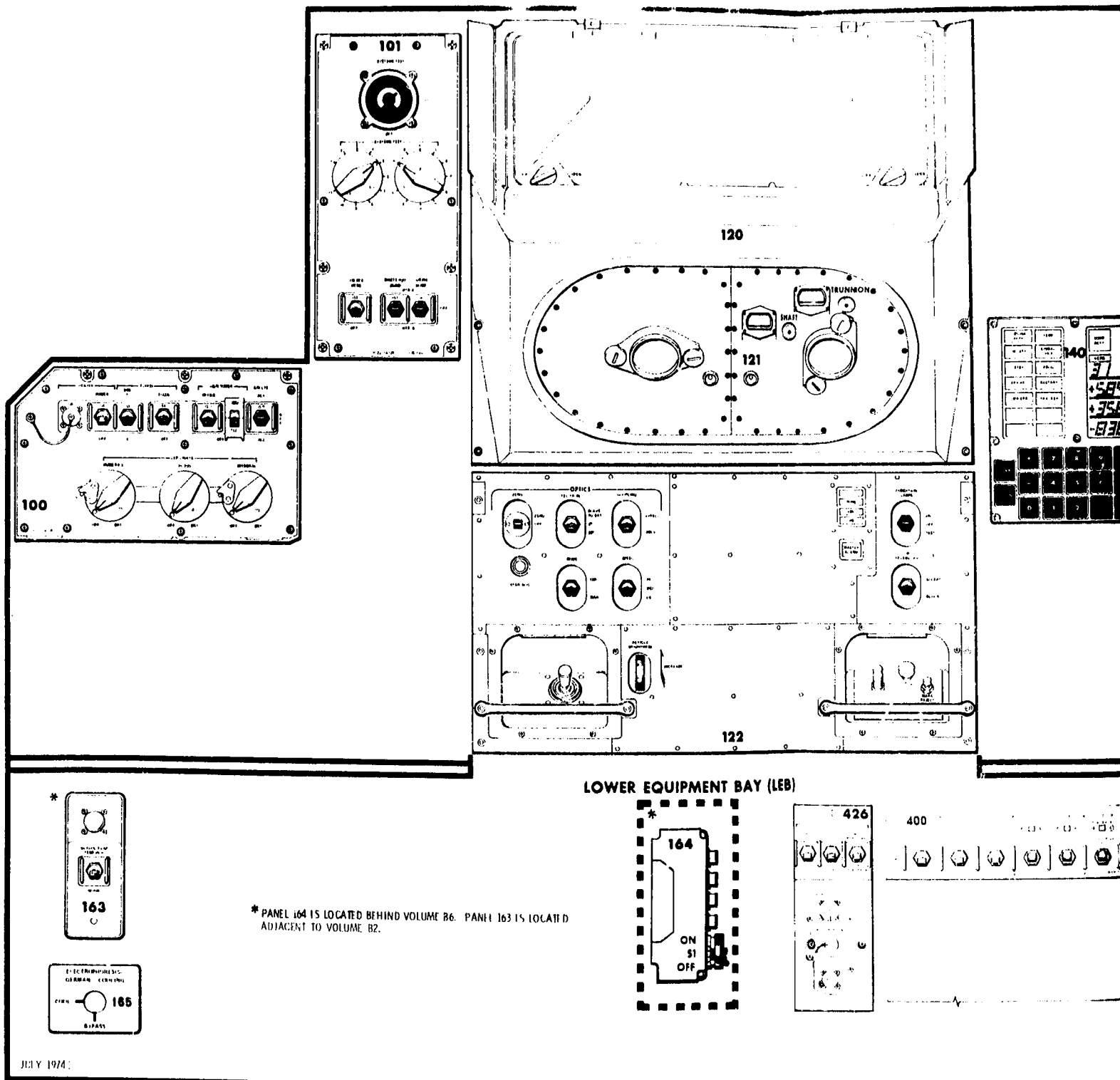

FOLDOUT FRAME

JULY 1974

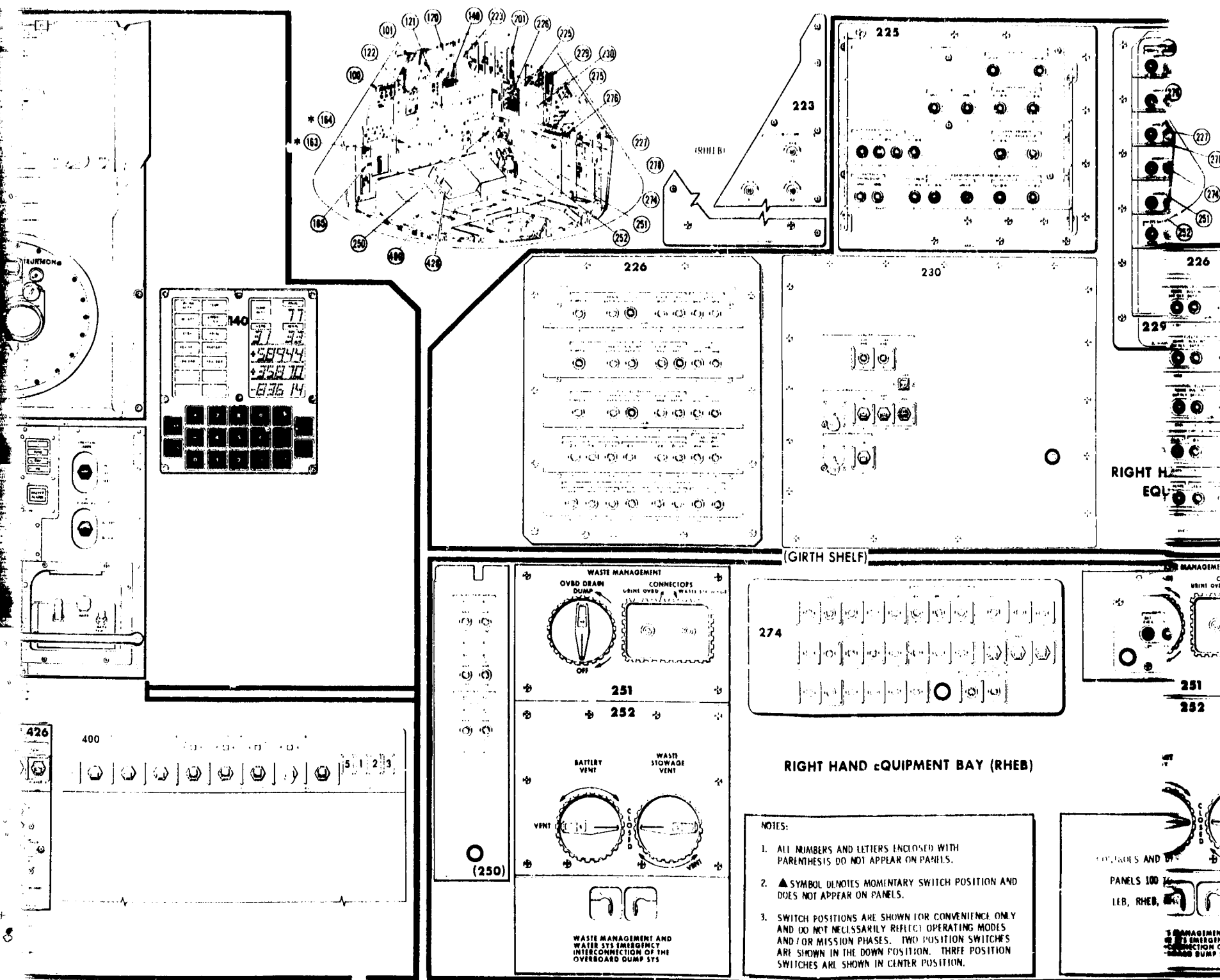

Figure A-1. Crew Displays and Controls

PROJECT TEAM

Basic Date 15 July 1974 Change Date

APOLLO-SOYUZ TEST PROJECT (ASTP)
OPERATIONS HANDBOOK

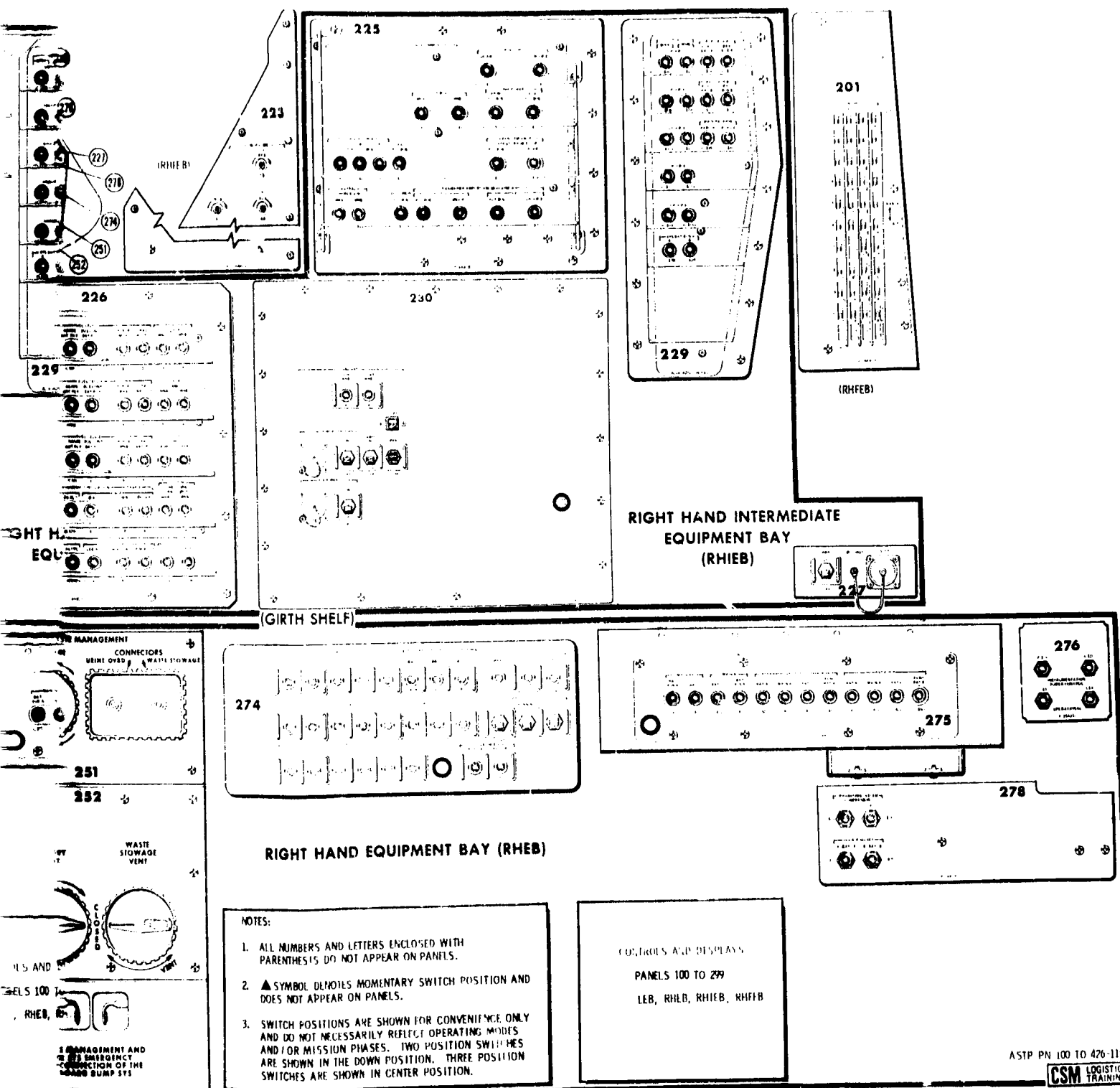
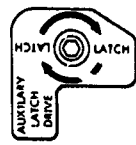
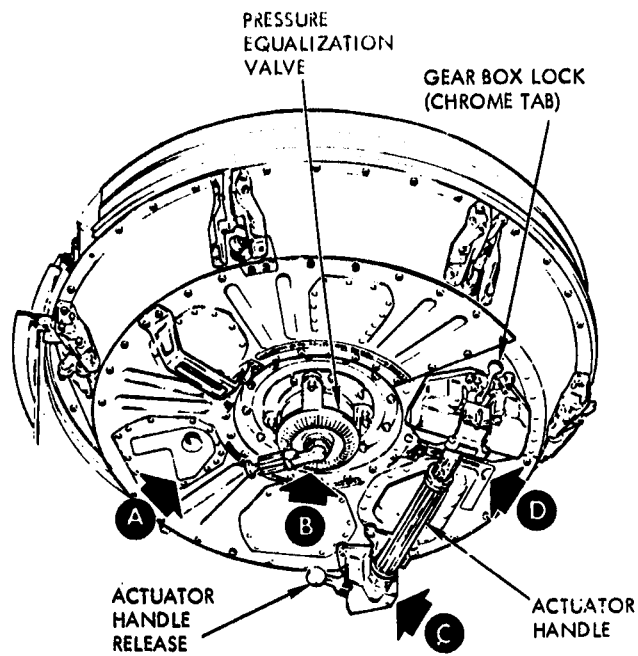
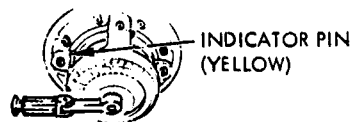

Figure A-1. Crew Displays and Controls (Sheet 4 of 5)

FORWARD HATCH



DETAIL A



DETAIL B

GEAR BOX DISCONNECT SOCKET (B TOOL)

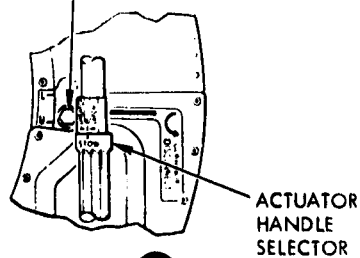

DETAIL D

SIDE HATCH

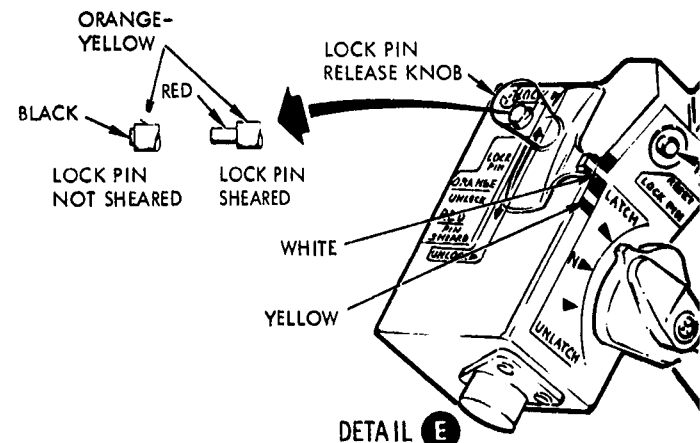
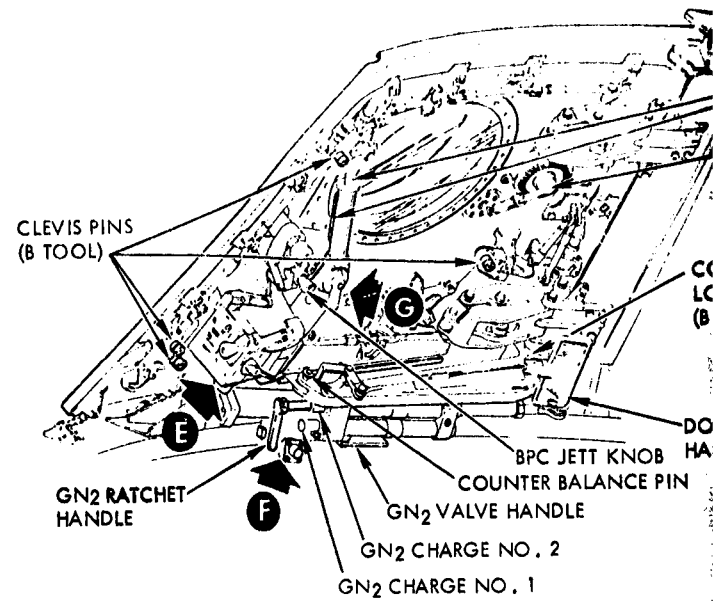

DETAIL E

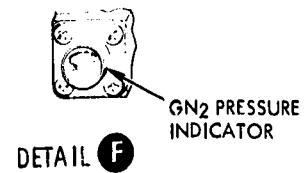

DETAIL F

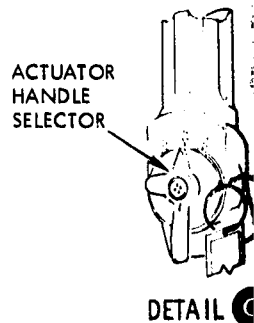

DETAIL C

FOLDOUT FRAME

SIDE HATCH

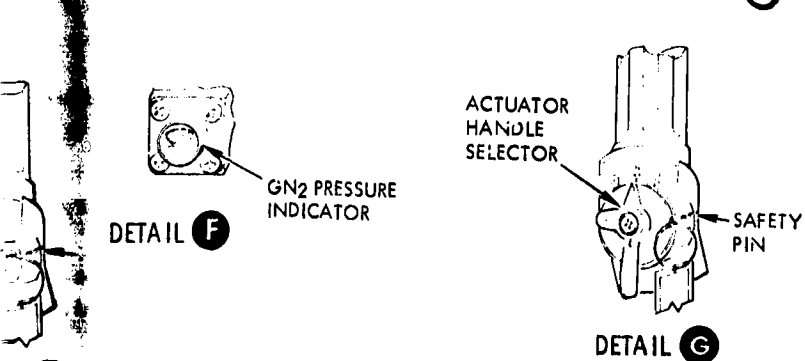
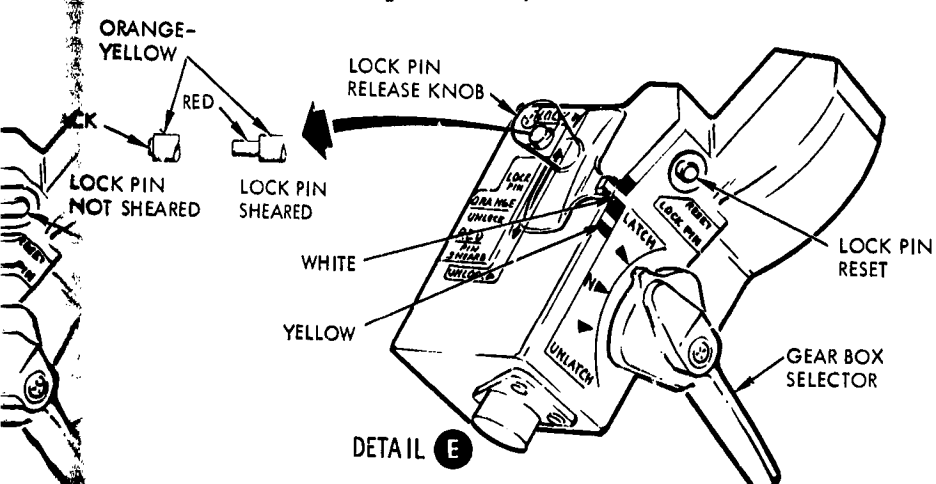
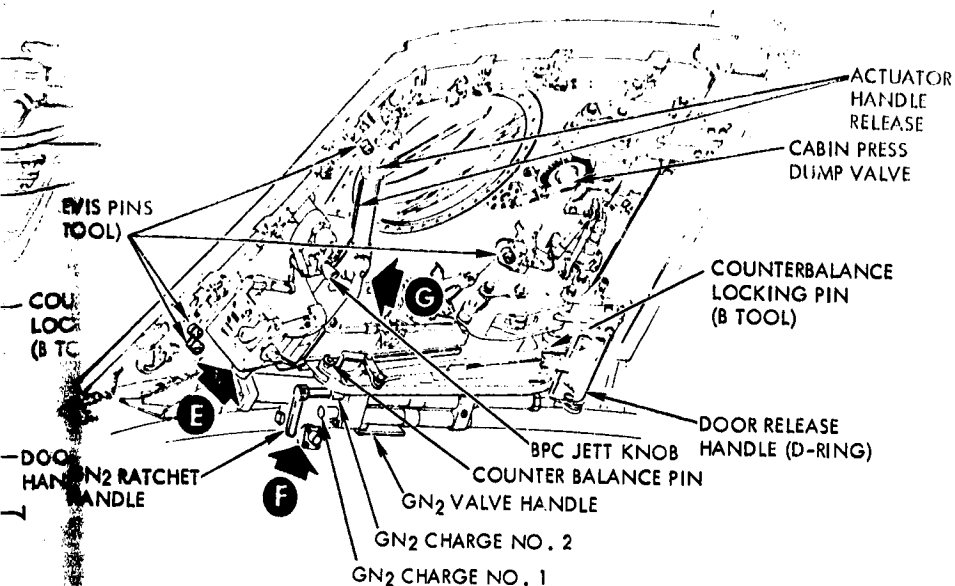

FOLDOUT FRAME

PROBE & TUNNEL

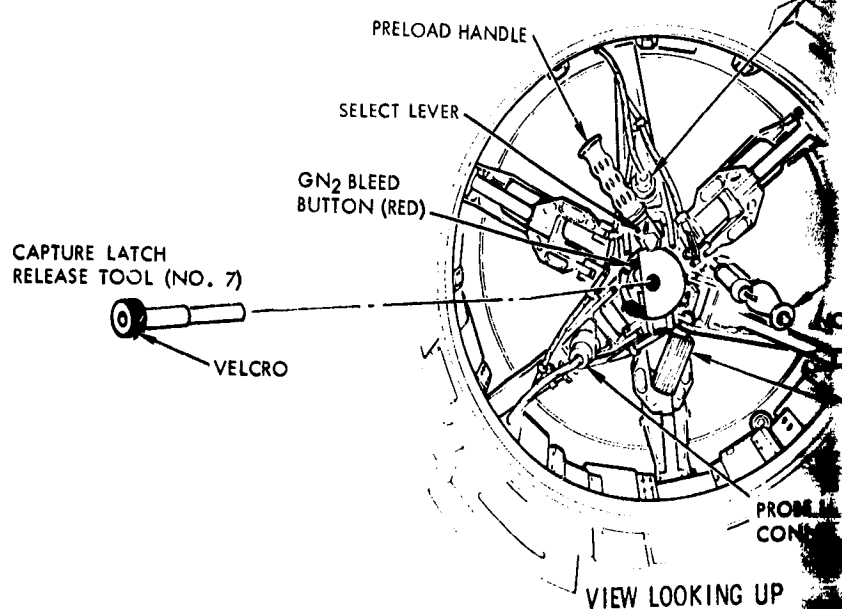
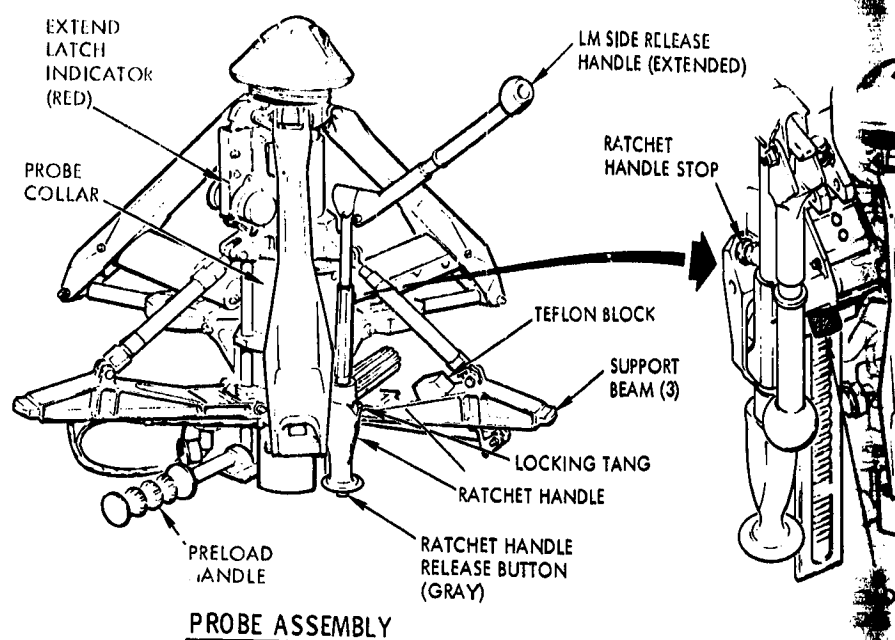
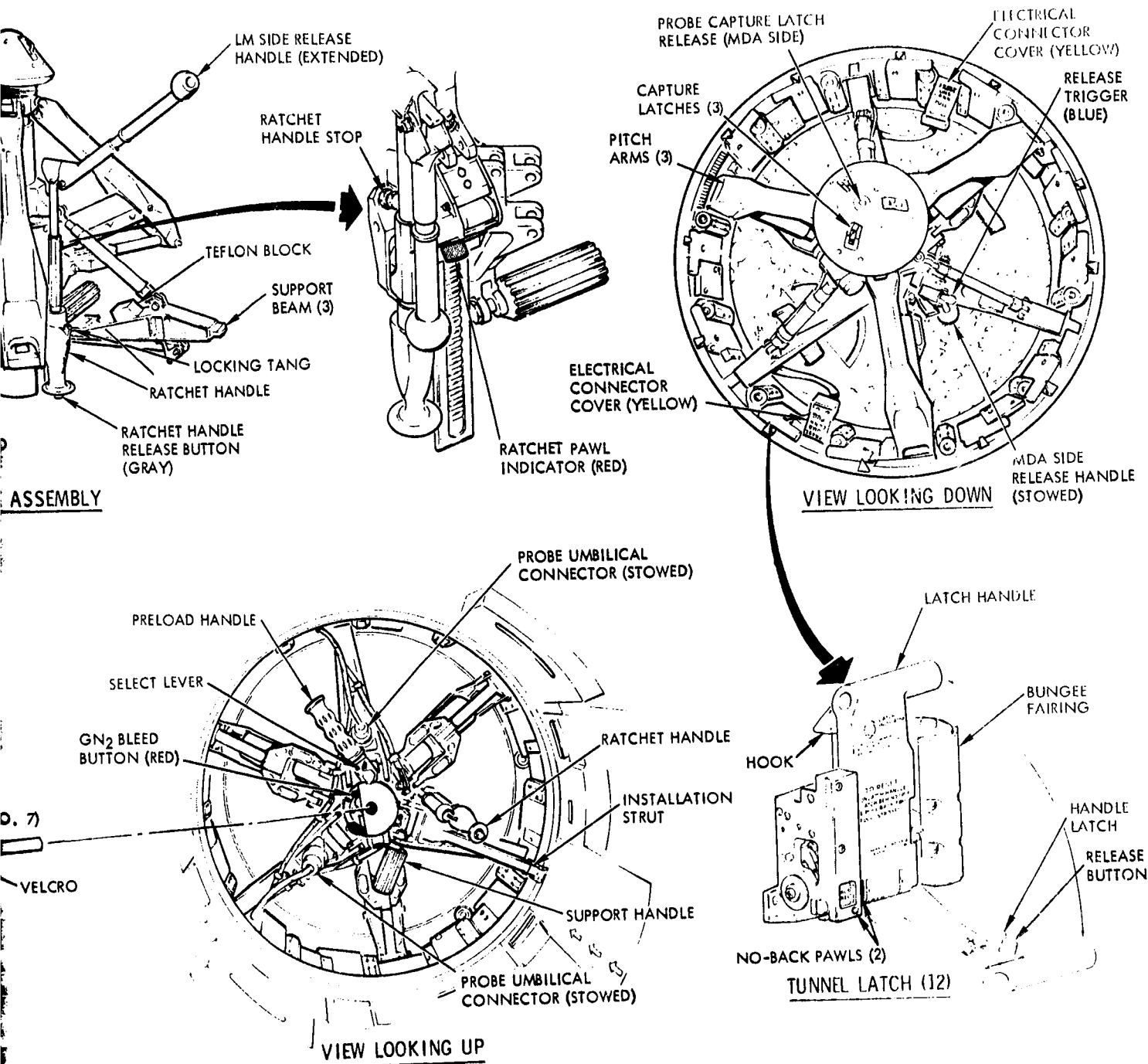

Figure A-1. Crew Display

APOLLO-SOYUZ TEST PROJECT (ASTP)
OPERATIONS HANDBOOK

PROBE & TUNNEL LATCHES



SM-2A-2003F

Figure A-1. Crew Displays and Controls (Sheet 5 of 5)

APOLLO-SOYUZ TEST PROJECT (ASTP)
OPERATIONS HANDBOOK

APPENDIX B

DM PANEL ILLUSTRATIONS AND CONTROL/INDICATOR CONFIGURATION LIST

This section contains LM panel illustrations and a control/indicator configuration list for DM. Panel illustrations present the location of the displays and controls as they appear on the panels in the DM (Figure B-1). The control/indicator configuration list provides the configuration of the DM displays and controls at lift-off, during the docked-occupied periods, the docked-unoccupied periods and the final closeout configuration which is synonymous with the DM jettison configuration.

A control or switch setting in brackets [] indicates a DM docked and occupied in a Soyuz high pressure mode.

REPRODUCIBILITY OF THE
ORIGINAL PAGE IS POOR

DM PANEL ILLUSTRATIONS AND CONTROL/INDICATOR CONFIGURATION LIST

AS 3415
7:00-5 7-9--114

APOLLO-SOYUZ TEST PROJECT (ASTP)
OPERATIONS HANDBOOK

DOCKING MODULE SWITCH CONFIGURATIONS				
	LIFTOFF	DOCKED - OCCUPIED	DOCKED - UNOCCUPIED	CLOSEOUT CONFIGURATION
PANEL 803				
DM SOYUZ TUMBL VENT ISOL VLV	CLOSE	CLOSE	CLOSE	CLOSE
DM SOYUZ TUMBL VENT VLV	CLOSE	CLOSE	CLOSE	CLOSE
PANEL 808				
UTILITY POWER	OFF	OFF	OFF	OFF
TV STATION SEL DM/SOYUZ	DM	as req	UP TIM	DM
TV STATION SEL DM1/DM2	DM1	as req	UP TIM	DM1
DMR SYNC	CM/DM	as req	CM/DM	CM/DM
DM1 TV STATION POWER	OFF	as req	OFF	OFF
DM2 TV STATION POWER	OFF	as req	OFF	OFF
PANEL 811				
AUDIO 1 POWER	OFF	OFF	OFF	OFF
PANEL 815				
DOPLER MTR	OFF	as req	as req	OPERATE
SS DOPLER MTR DMA	open	as req	as req	open

APOLLO-SOYUZ TEST PROJECT (ASTP)
OPERATIONS HANDBOOK

CB WALL HTS DMS	close	open	close	open
CB WALL HTS DMS	close	open	close	open
CB CABIN FAN DMS	close	close	close	open
CB CABIN WARM DMS	open	close	open	open
CB INST DMS	close	close	close	open
CB INST DMS	close	close	close	open
CB LIGHTING 1-DMS	open	close	close	open
CB LIGHTING 2-DMS	close	close	close	open
CB UTILITY DMS	open	close	close	open
CB VHS FM XCVR DMS	close	close	close	open
CB IM AUDIO/TV DMS	open	close	close	open
CB SOYUZ POWER DMS	open	open	open	open
CB DMS/DMS TIE	open	open	open	open
LIGHTING 1	OFF	OFF	OFF	OFF
LIGHTING 2	START	ON	ON	START
PANEL 818				
AUDIO C POWER	OFF	ON	OFF	OFF

PANELS 803 THRU 818

APOLLO-SOYUZ TEST PROJECT (ASTP)
OPERATIONS HANDBOOK

	LIFTOFF	DOCKED - OCCUPIED	DOCKED - UNOCCUPIED	CLOSEOUT CONFIGURATION
PANEL 821				
HIGH PRESS RELIEF 1 VLV	AUTO	AUTO	AUTO	AUTO
HIGH PRESS RELIEF 2 VLV	AUTO	AUTO	AUTO	AUTO
PANEL 824				
DM NO PRESS VLV	OFF	OFF	OFF	OFF
DM NO PRESS ISOL VLV	CLOSE	OPEN	OFF	OFF
O2 REG A VLV	OFF	ON	OFF	OFF
O2 REG B VLV	OFF	ON	OFF	OFF
SUPPLEMENTAL O2 FLOW VLV	OFF	OFF	OFF	OFF
O2 PURGE VLV	close (cw)	close (cw)	close (cw)	close (cw)
PRESS RELIEF VLV REP	DM	DM	DM	DM
PANEL 826				
EMER PRESS REG VLV	OFF	BOTH	OFF	OFF

APOLLO-SOYUZ TEST PROJECT (ASTP)
OPERATIONS HANDBOOK

REPRODUCIBILITY OF THIS
ORIGINAL PAGE IS POOR

PANEL 828			
WAKE UP VLV	OFF	OFF	OFF
LOW PRESS RELIEF VLV	CLOSE	CLOSE	CLOSE
LOW PRESS RELIEF VLV	CLOSE	CLOSE	CLOSE
PANEL 856			
DOCK SYS A TEST SEL	OFF	OFF	OFF
DOCK SYS B TEST SEL	OFF	OFF	OFF
PANEL 860			
IGNITION	OFF	as req	OFF
POWER	OFF	ON	OFF
SIGNAL	OFF	on(up)	OFF
VOLUME SW	decr	as req	decr
PANEL 861 (RUSSIAN J-BOX)			
MICROPHONE	OFF	as req	OFF
TV CAMERA-1	OFF	as req	OFF
TV CAMERA-2	OFF	as req	OFF
WFF - 2 volume	decr (ccw)	as req	decr (ccw)

PANELS 821 THRU 861

APOLLO-SOYUZ TEST PROJECT (ASTP)
OPERATIONS HANDBOOK

	LIMIT OFF	DOCKED - OCCUPIED	DOCKED - UNOCCUPIED	STATUS CONFIGURATION
OFF INTERCOM VOLUME	decr (cov)	as req	as req	decr (cov)
PANEL 962				
GUIDE RING SWICH LIMIT SW	NORMAL	NORMAL	NORMAL	NORMAL
GUIDE RING REGR LIMIT SW	NORMAL	NORMAL	NORMAL	NORMAL
SB GEN CRISTAL GROWTH MGA	oper.	as req	open	open
GEN CRISTAL GROWTH PWR	OFF	as req	OFF	OFF
PANEL 900				
DM VENT ISOL VAL	CLOSE	CLOSE	CLOSE	CLOSE
DM VENT VAL	CLOSE	CLOSE	CLOSE	CLOSE
DM PRESS RELF VAL	cap - off	cap - on	cap - off	cap - off
PANEL 901				
DM PRESS ISOL VAL	CLOSE	CLOSE	CLOSE	CLOSE
DM PRESS VAL	OFF	OFF	OFF	OFF
PANEL 960 (LOCATED IN SOYUZ)				
DM PRESS	N/A	off (ctr)	off (ctr)	off (ctr)
DM PRESS	N/A	ON	ON	OFF

Basic Date: _____ Change Date: _____

APOLLO-SOYUZ TEST PROJECT (ASTP)
OPERATORS HANDBOOK

	N/A	ON	ON	OFF
	N/A	as req	decr	decr
PANEL 961 (LOCATED IN SOYUZ)				
AUDIO POWER	N/A	ON	ON	OFF
TV/VIDEO POWER	N/A	ON	ON	OFF
HATCH 1				
PRESS EQUAL VALVE	CLOSE	N/A	N/A	CLOSE
HATCH 2				
PRESS EQUAL VALVE	CLOSE	OPEN [CLOSE]	CLOSE	CLOSE
HATCH 3				
PRESS EQUAL VALVE	CLOSE	CLOSE [OPEN]	CLOSE	CLOSE

REPRODUCIBILITY OF THE
ORIGINAL PAGE IS POOR

PANELS 862 THRU 961 AND HATCHES

APOLLO-SOYUZ TEST PROJECT (ASTP)
OPERATIONS HANDBOOK

DOCKING MODULE

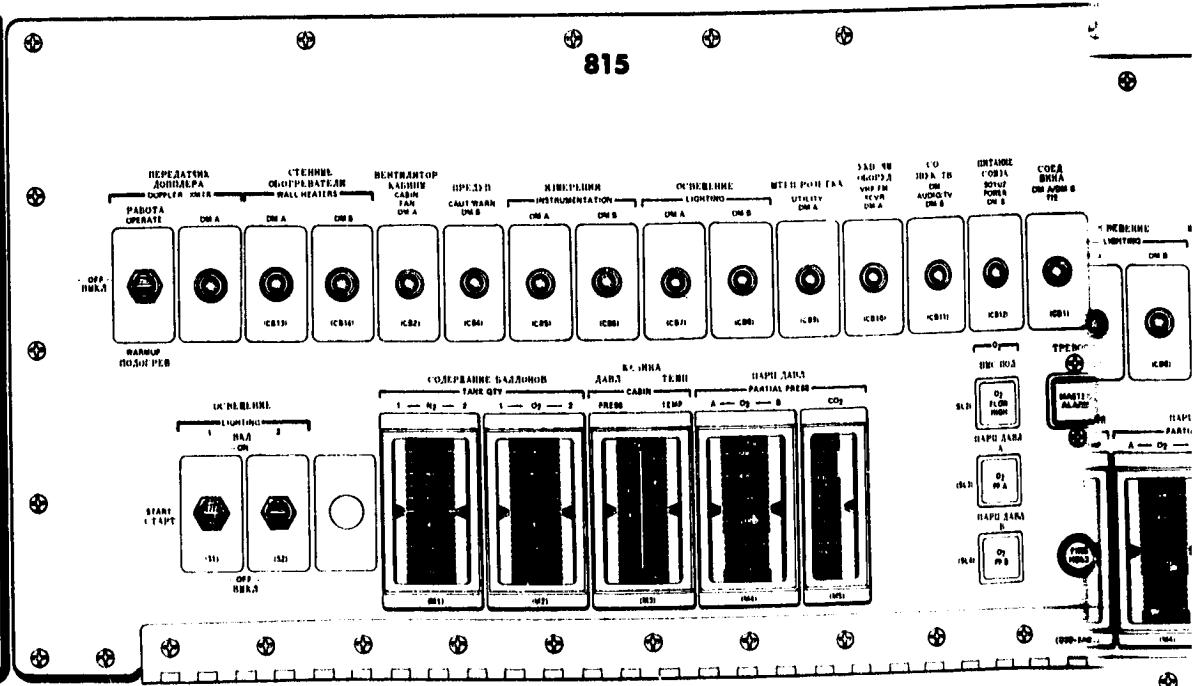
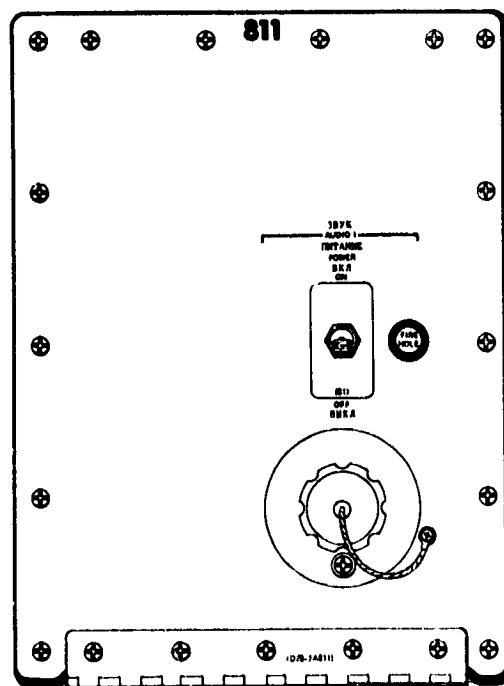
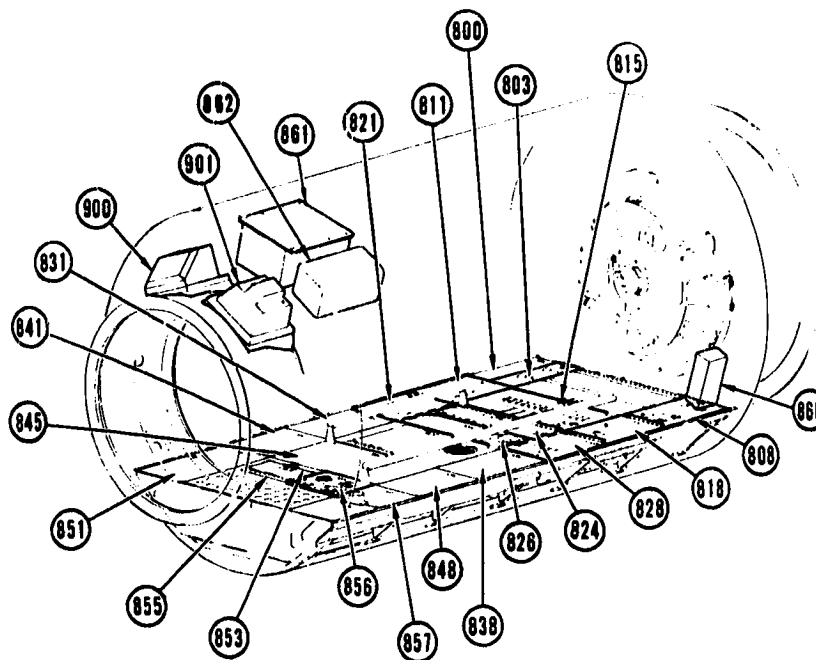
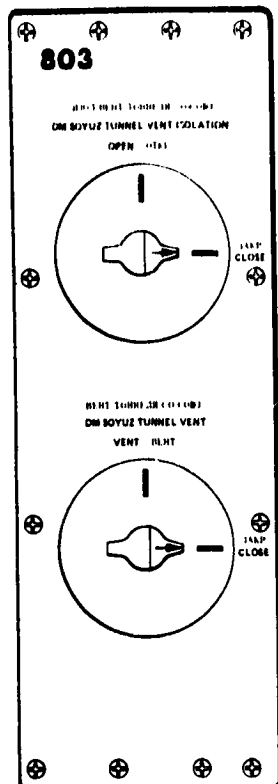

FOLDOUT FRAME

Figure B-1. DM Crew Displays and Controls (Sheet 1 of 3)

DULE

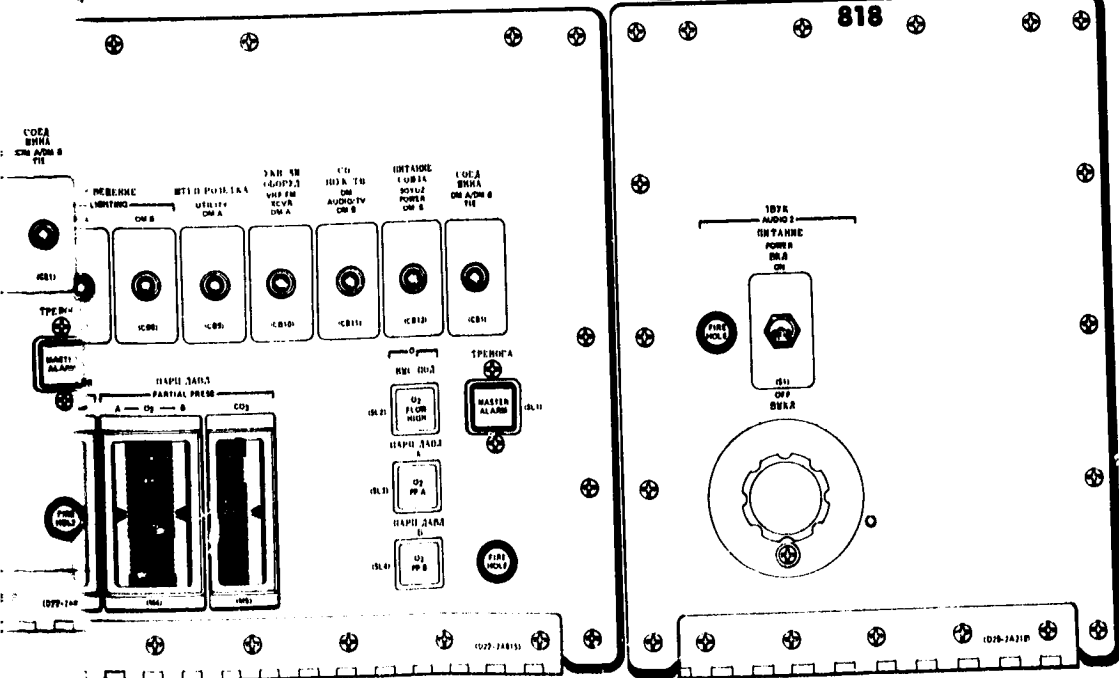
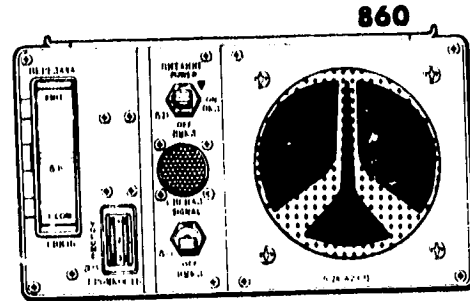
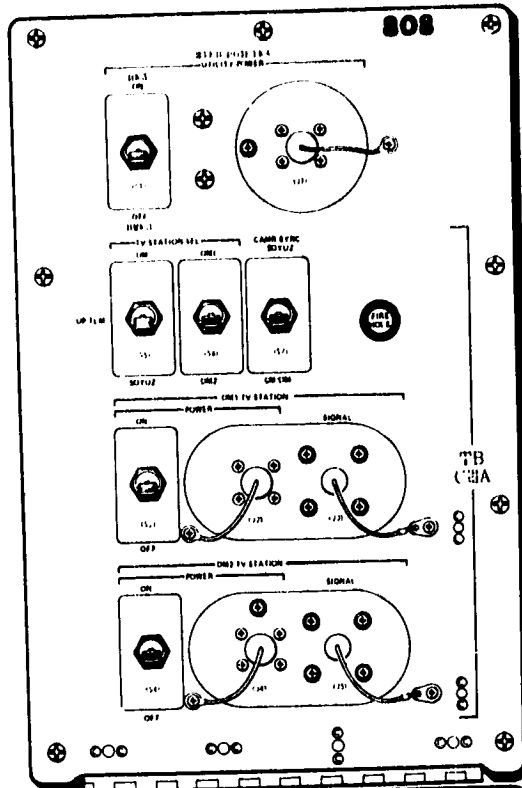
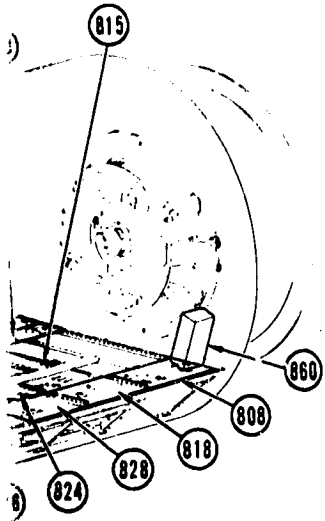

ASTP-DM-PN-800 TO 901-C

CSM LOGISTICS TRAINING

3) HOLDOUT TEAM

9) B-9/B-10

APOLLO-SOYUZ TEST PROJECT (ASTP)
OPERATIONS HANDBOOK

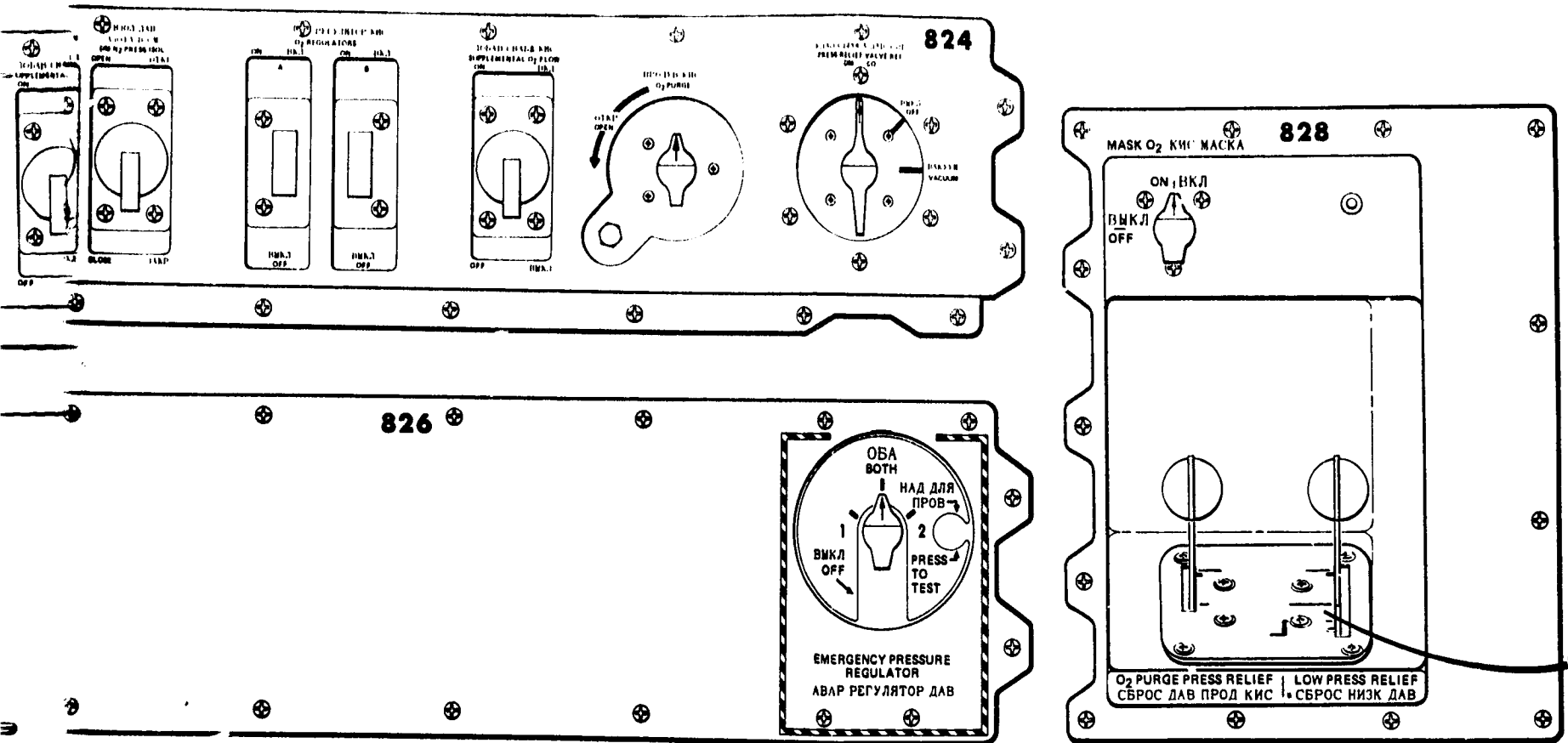

Figure B-1. DM Crew Displays and Controls (Sheet 2 of 3)

FOLDOUT FRAME.

APOLLO-SOYUZ TEST PROJECT (ASTP)
OPERATIONS HANDBOOK

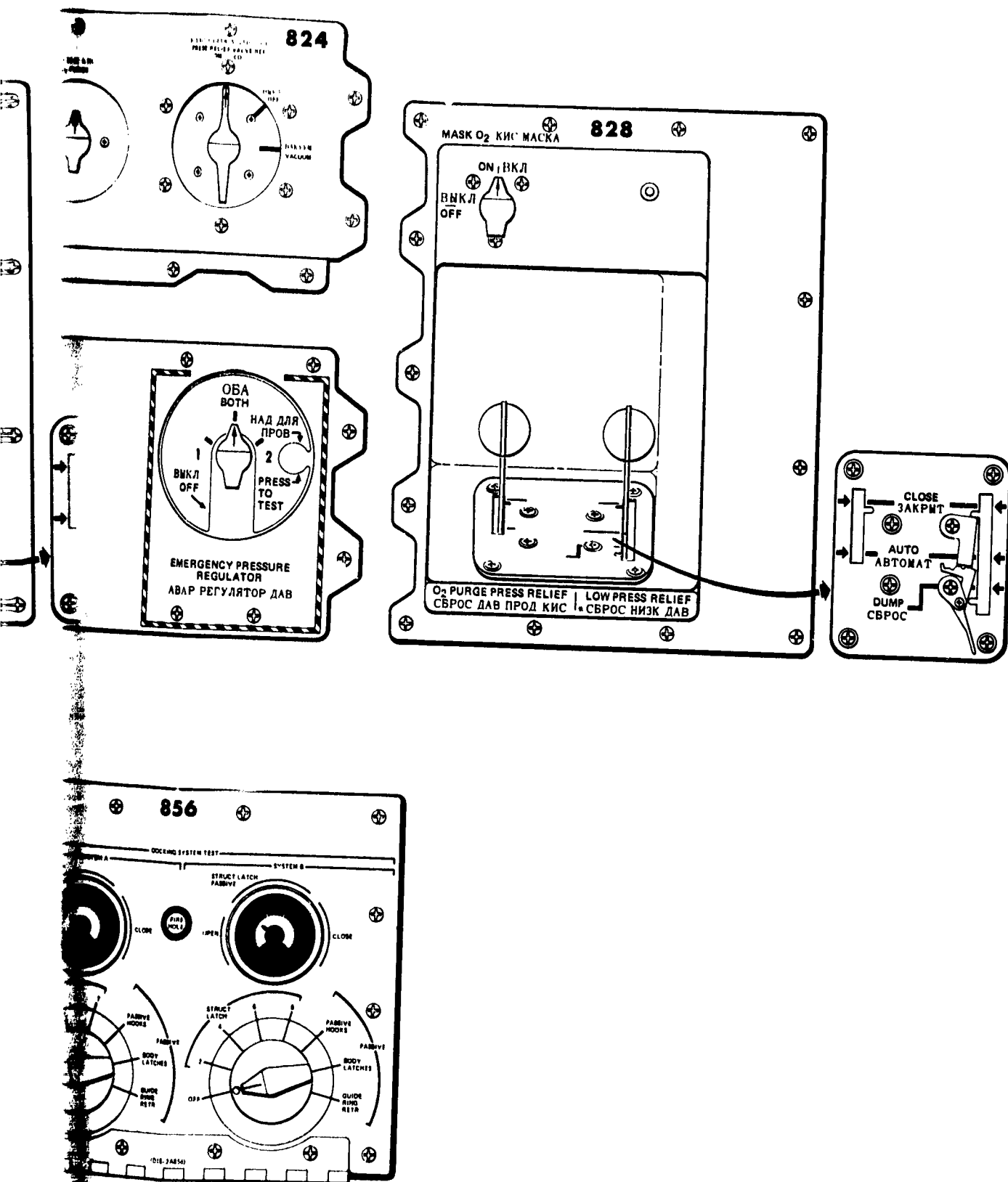
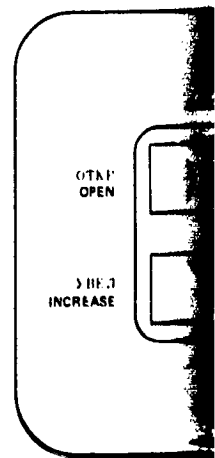
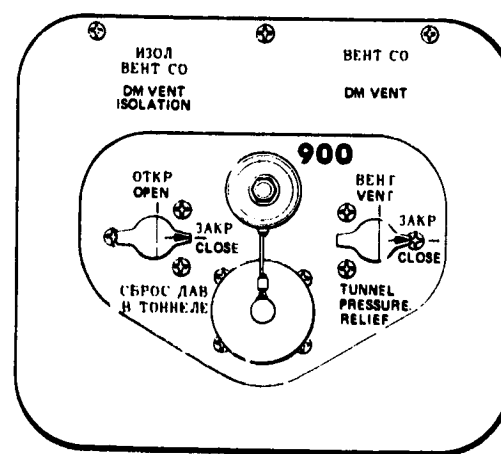
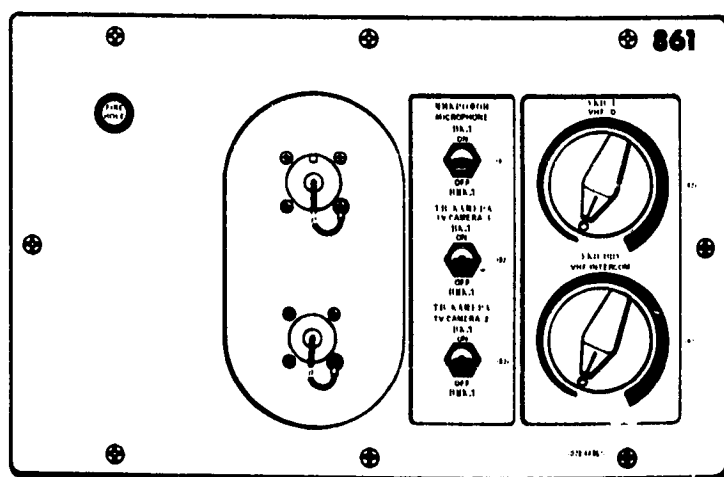
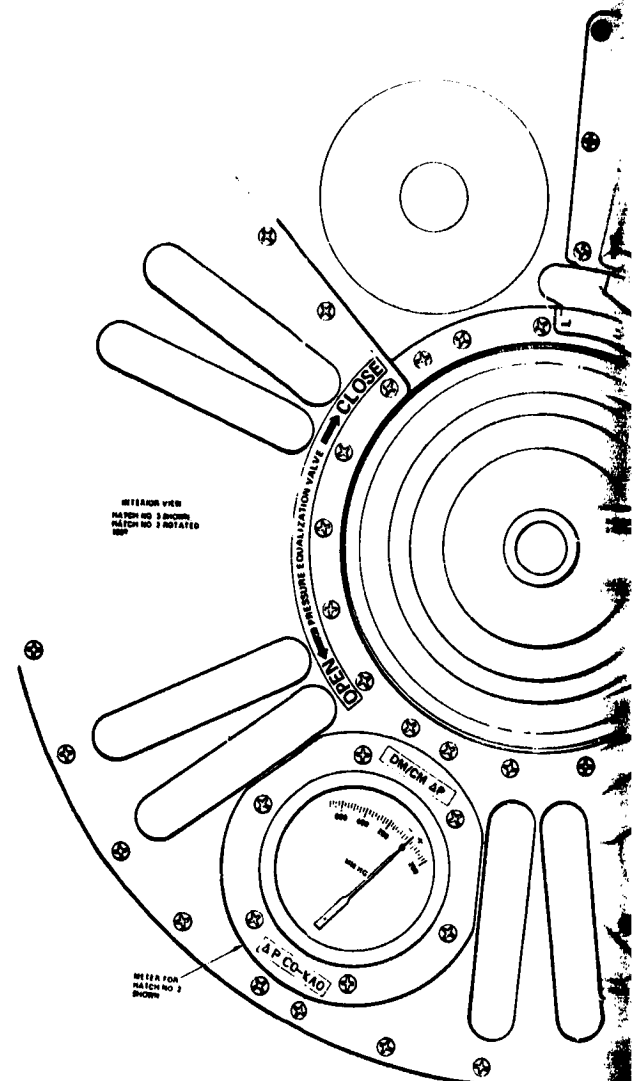
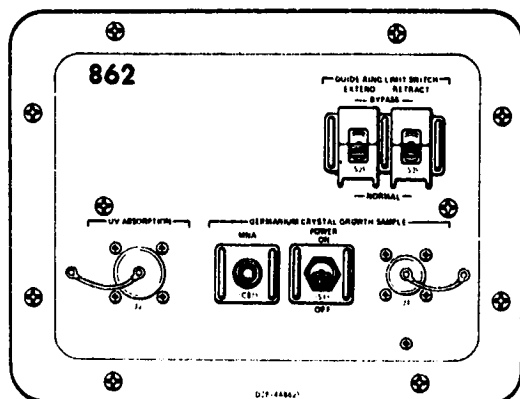
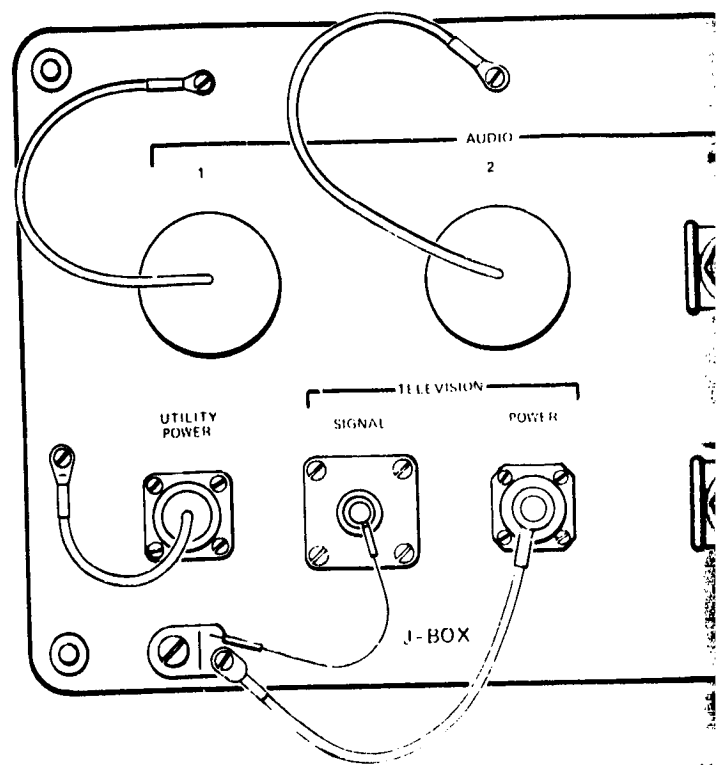
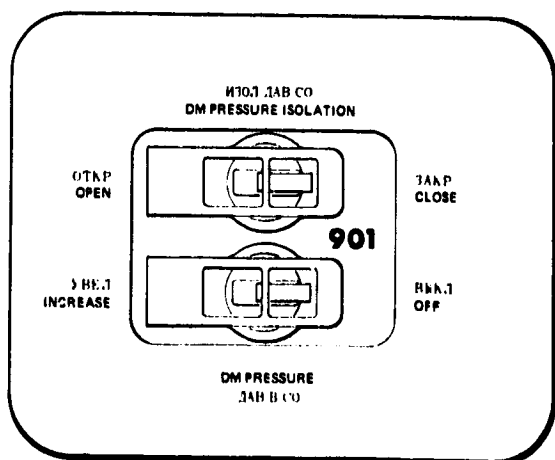
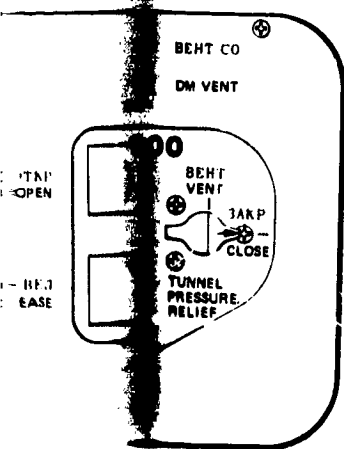
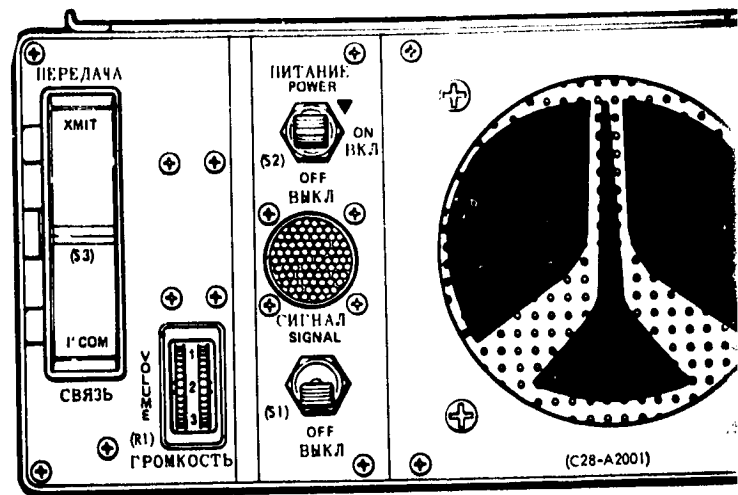
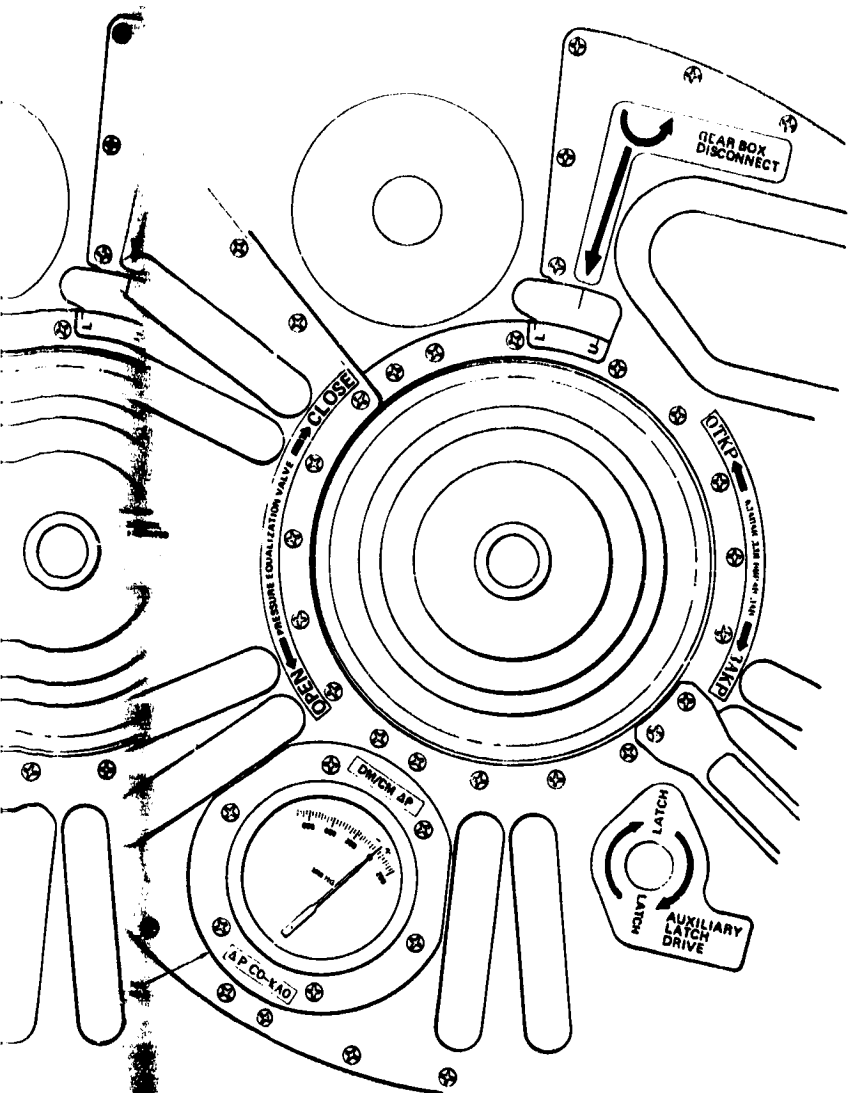

Figure B-1. DM Crew Displays and Controls (Sheet 2 of 3)



SOYUZ

960



ASTP-SOYU

Figure B-1. DM Crew Displays and Controls (Sheet 3 of 2)

SOYUZ

960

960

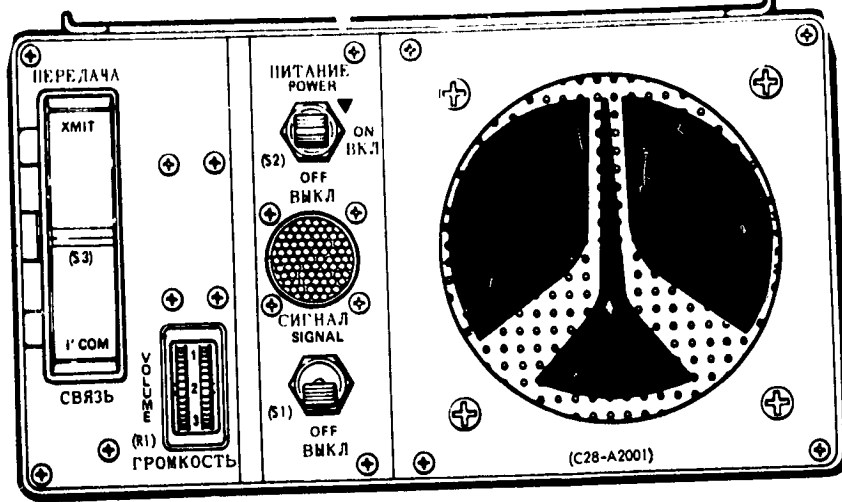

9

961

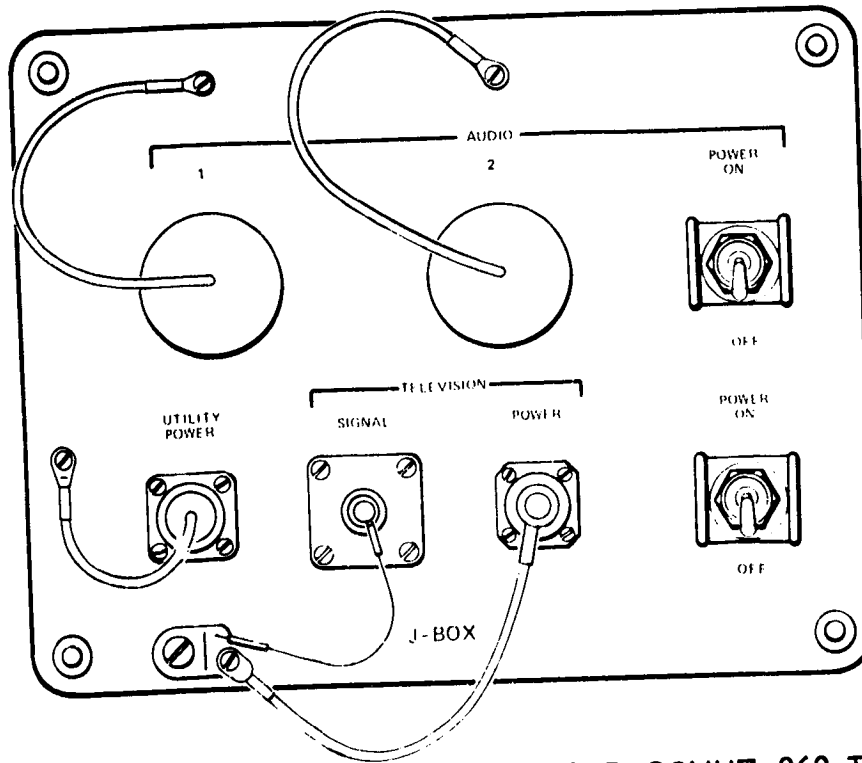

ASTP-SOYUZ-960 TO 961-B

CSM LOGISTICS TRAINING

Figure B-1. DM Crew Displays and Controls (Sheet 3 of 3)

FOLDOUT FRAME