

FLIGHT FLUTTER TESTING OF SUPERSONIC INTERCEPTORS

M. Dublin, R. Peller — Convair, San Diego, California

Abstract

This paper presents a summary of experiences in connection with flight flutter testing of supersonic interceptors. It contains a description of the planning and operational aspects involved, comments on the difficulties encountered, and shows correlation between measurement and theory. The paper concludes with recommendations for future research and development to advance the science of flight flutter testing.

INTRODUCTION

During the last ten years, as noted in Reference (1), more than fifty different cases of flutter have been encountered on United States piloted military aircraft. In addition a certain number of cases of flutter have also been encountered on United States commercial and private aircraft. Further, a number of cases of flutter have been encountered on United States military missiles. Although detail statistics are not available, it is known that a number of cases of flutter have occurred on foreign aircraft and missiles. Thus, over the last ten year period, it is estimated that at least several hundred cases of flutter have been encountered in airborne vehicles of the world.

These cases of flutter have had various consequences. In some cases mild structural damage occurred and the aircraft was landed safely. In some cases very severe structural damage occurred and the aircraft had to be abandoned. With regard to the flutter cases encountered in the United States over the aforementioned time period, insofar as the authors know, no loss of life was encountered; whether the same applies to flutter cases encountered on foreign aircraft is not known to the authors. Other aspects of encountering flutter which are important are that it

results in a considerable expense of time, money and material to obtain a fix; it delays getting the vehicle into operational use; and it can sometimes result in permanent restrictions on the airborne vehicle which limits its operational capability.

From an analytical point of view the determination of the flutter stability boundaries is difficult because of lack of precise knowledge of all the parameters used in the equations of motion; Reference (1) outlines these difficulties in more detail and also considers difficulties encountered in flutter model testing. Flight flutter tests are therefore made to insure freedom of the vehicle from flutter over its operating envelope and environment, and to assist the flutter analyst in improving his ability to make analytical predictions.

PLANNING ASPECTS

The steps which must be taken in planning a flight flutter test program are as follows:

- a. Establish desired data and measurements.
- b. Selection of test equipment and installation.
- c. Establish test procedure and execute test.
- d. Data analysis and interpretation.

Although there are a variety of approaches for each of the above steps, this paper will only consider the approaches used by Convair in flight flutter testing of supersonic interceptors. Figure 1 shows a photograph of one of the configurations tested. Practical difficulties encountered during the flight flutter test program will also be discussed.



Figure 1. USAF F-102A Supersonic Interceptor

Desired Data and Measurements

The method chosen for establishing flutter stability was to obtain plots of the damping coefficients at selected locations on the airplane versus airspeed for selected resonant frequencies (i.e., both symmetric and antisymmetric), for selected altitudes and for selected airplane mass configurations. Required measurements using this method were the airplane responses (at the selected locations due to an excitation of the airplane), the airspeed, and the altitude.

Two excitation methods were employed, namely sinusoidal excitation by two inertia shakers, and pilot control excitation. To establish that the shakers were functioning properly, it was also necessary to measure the frequency and the displacement of each shaker mass and the phase of one shaker mass displacement with respect to the other shaker mass displacement. Pilot control forces or displacements were not measured since movable control surface responses were adequate to establish initiation of pilot control excitation.

A problem area arose in selecting the airplane mass configurations. For the airplane configuration without external wing fuel tanks, the fuel weight is approximately 25% of the airplane takeoff gross weight. Since fuel is expended at a fairly rapid rate, it was not practical to specify a mass configuration for which measurements should be taken at specific speeds and altitudes; it was necessary to take measurements at points on the flight envelope at the mass configuration which existed. This, of course, leads to one of the difficulties in correlating measurements with theory since in practice analytical investigations are usually made for a limited number of weight configurations. However, for the airplane configuration with external wing fuel tanks, it was possible to take measurements for various external

fuel tank configurations. Three fuel tank configurations were selected, namely external tanks with full fuel, external tanks with half fuel and forward center of gravity, and external tanks with half fuel and aft center of gravity. Special compartmented tanks were used for these tests.

TEST EQUIPMENT AND INSTALLATION

The equipment used for the tests consists of:

- a. Excitation system
- b. Pickups
- c. Recording system
- d. Data analysis system

Description of this equipment is discussed hereunder.

EXCITATION SYSTEM

Based on an examination of the theoretical vibration modes, it was established that the shakers should be located near the wing tips in order to obtain satisfactory airplane response for all desired exciting frequencies. The wing depth available at the selected location was 4.5 inches for the shaker and its mounting. Since no commercially available shaker existed which met this space requirement and at the same time provided desired force output for satisfactory airplane response, it was necessary to design and develop a shaker system specifically tailored for this airplane. Convair developed such a shaker system which is essentially a closed loop servo system combining hydraulics and electronics to command and control the movement of two reciprocating masses. A functional block diagram of the system is shown in Figure 2; detail description of the system is contained in Reference 2. The essential elements of this system consists of the following:

- a. Pilot's stick switch. This is a spring loaded on-off switch which when actuated causes the shaker to perform the functions selected on the pilots control panel.
- b. Pilot's control panel. Three two position toggle switches are located on the pilots control panel which permit him to select either a manual or an automatic mode of operation. If the manual mode of operation is selected this causes the shakers to sweep through a specified frequency range at a programmed rate of sweep, and at a programmed shaker force; in this case the pilot must also select the phasing of the shakers (i.e., symmetric or antisymmetric), and he must also select the sweep cycle (i.e., ascending frequency or descending frequency). If the automatic mode of operation is selected this permits obtaining decay responses; in this mode of operation six frequencies (either symmetric or anti-

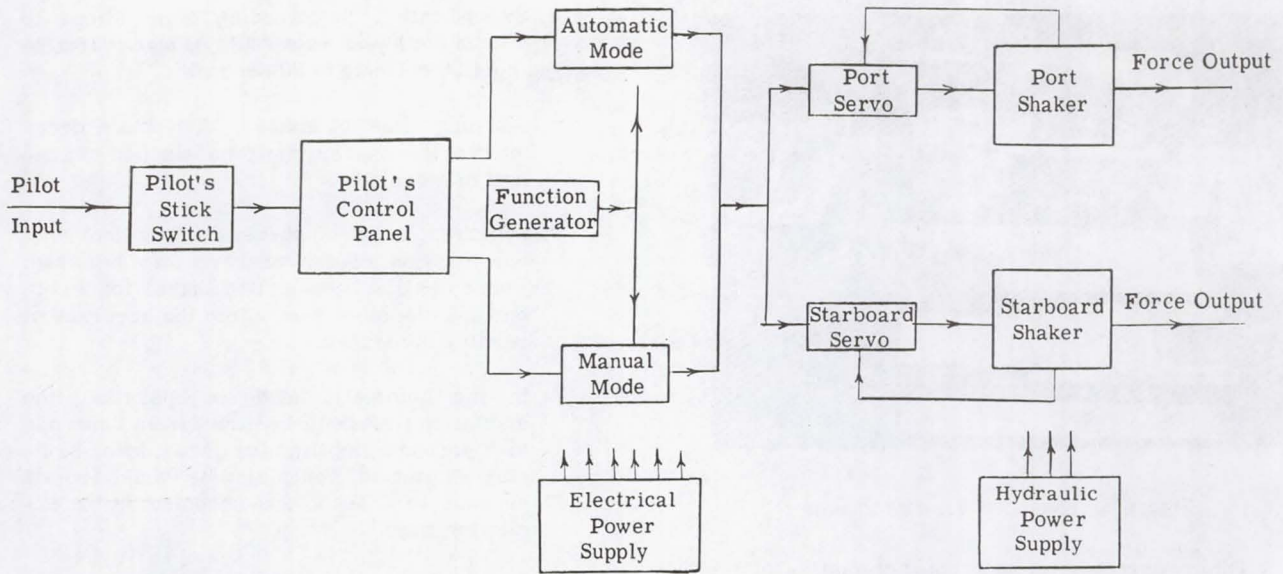

Figure 2. Functional Block Diagram of Shaker System

symmetric) can be preselected and the shakers will excite the airplane for a specified time at a given frequency; stop the shakers for a specified time and automatically step to the next frequency -- this process is repeated as long as the pilot stick switch is engaged. A programmer is used to accomplish these functions in the automatic mode of operation. Figure 3 shows a photograph of the programmer.

- c. Function generator. This is used to generate the desired sine wave shape.
- d. Two servos. These are used to control the force output of the shakers.

e. Two hydraulically actuated shakers. These supply the force input to the airplane. Figure 4 shows a photograph of an assembled shaker. Figure 5 shows a photograph of the shaker partially disassembled; the cylinder in the photograph is the shaker mass.

f. Electrical power supply. This consisted of the airplane 400 cycle A. C. and 28 volt D. C. power supplies.

g. Hydraulic power supply. A separate 3,000 psi hydraulic power supply was installed in the airplane for the shaker system.

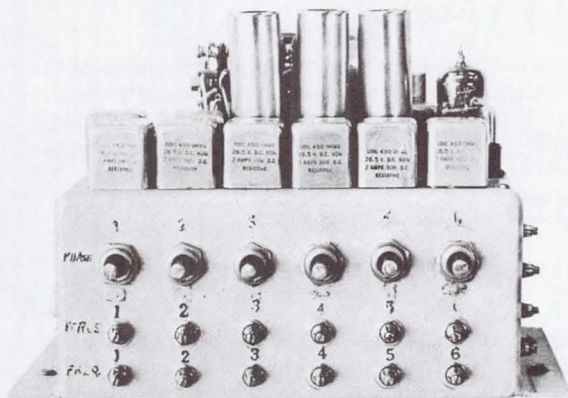

Figure 3. Shaker Programmer

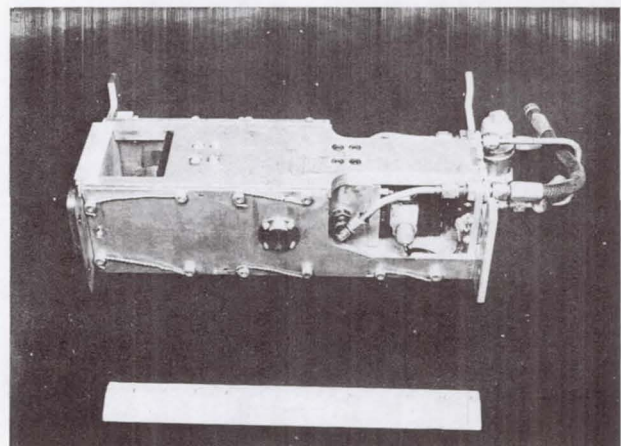

Figure 4. Assembled View of Shaker

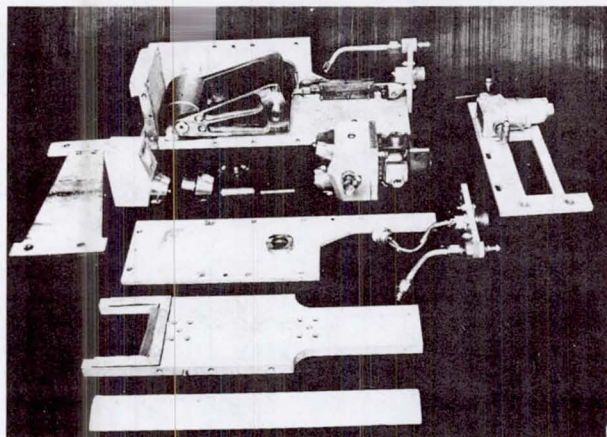

Figure 5. Exploded View of Shaker

Other pertinent design characteristics of the shaker system are:

- a. Force vs frequency. A linear variation of force versus frequency was desired. However, due to valve characteristics the force-frequency curve actually obtained was as shown in Figure 6. It is noted that identical force outputs for both starboard and port shakers were not obtained.

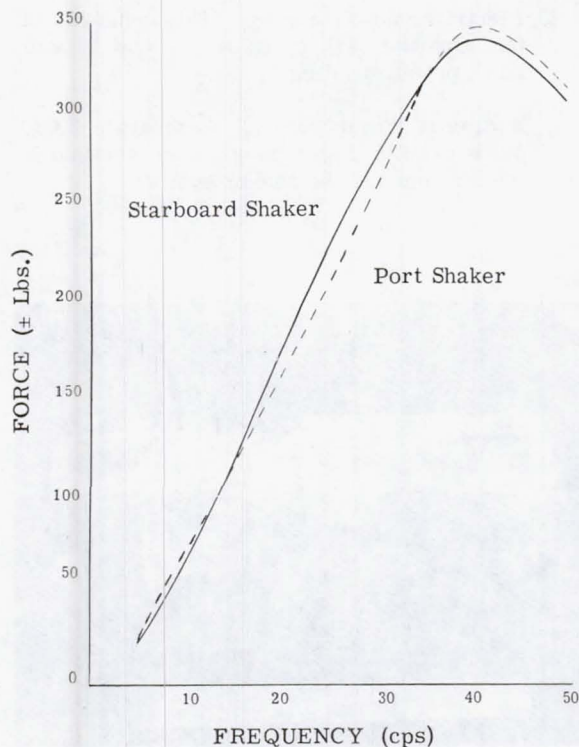

Figure 6. Shaker Force vs. Frequency

- b. Sweep rate. In sweeping from 5 cps to 50 cps the sweep rate could be made variable from 55 seconds to 90 seconds.
- c. Stopping time of shaker. To obtain decay curves the shaker could be stopped in one-half of a cycle.
- d. Synchronization of shakers. Excellent synchronization of the shakers was achieved. Phase desired between one shaker force output and the other was within the accuracy of reading the traces.
- e. In the automatic mode of operation, the excitation time could be varied from 2 seconds to 7 seconds; the time for decay, after stopping excitation, could also be varied from 2 seconds to 7 seconds independent of the excitation time.
- f. The shaker mass weight was 8.5 lbs. and its travel was $\pm 1.0''$.

Trouble encountered with the shaker system were:

- a. Hydraulic leaks.
- b. Deterioration and failure of tubes in the electronic control system.
- c. Shorts in programmer stepping switches.
- d. Potentiometers in programmer were sensitive to temperature.
- e. Human errors in operating and maintaining the shaker system.

The shakers were installed in the wing on rigid structure as shown in Figure 7. Shaker force was established from measurements of the shaker mass displacement and frequency.

Pilot control excitation simply consisted of the pilot "banging" the control stick (i.e., longitudinally and laterally) with his hand or the rudder pedal with his foot. This method would only excite the lowest symmetric and the lowest antisymmetric vibration modes.

PICKUPS

Fixed surface responses were obtained by seven MB-124 linear velocity pickups located as shown in Figure 7. Movable surface responses were obtained by three MB-124 linear velocity pickups which were modified (i.e., by counterbalancing the movable armature) to sense angular velocity; these were located as shown in Figure 7.

- c. Necessity of changing tape during the flight when only one tape recorder was available.
- d. Failure of recording pens on Sanborn equipment.
- e. Radio failure (either airplane or ground radio).

slow paper speed of approximately 0.5 inches per second.

The data correlation trace was recorded on the oscillograph records along with the airplane responses. This allowed complete correlation with the speed information obtained from the photopanel.

Photopanel records were developed by standard procedures and read by means of projection equipment.

The data station proved to be a very reliable piece of equipment. Such difficulties as were encountered could be attributed to human errors.

DATA ANALYSIS SYSTEM

The data which was stored in the form of an electrical signal on magnetic tape was processed in a data station. The signals were put through appropriate discriminators and oscillograph traces obtained. A standard procedure which recorded all pickups with 60 cycle low-pass filters was run off first. If these records proved unreadable because of excessive response due to atmospheric turbulence, a band-pass filter from 25 to 50 cps was used to eliminate the low frequency responses. If the higher frequencies made decays in the fundamental modes unreadable, a 5 to 25 cps band pass filter was used.

The oscillograph records were, in general, recorded at a paper speed of 4 inches per second. For special conditions, (i.e., obtaining an overall view of a sweep) the records were recorded at a

TEST PROCEDURE AND EXECUTION OF TEST

An initial plan was made outlining the desired speed-altitude points which were required. This plan was flexible in that speed increments could be increased or decreased depending on the results obtained from each flight. Figure 8 shows a typical speed-altitude test plan. Tests were initiated at subsonic speeds at the highest altitude chosen. Tests at lower altitudes were always made in such a manner that the equivalent speed obtained at high altitude was not exceeded. Frequencies at which decays were obtained were established from sweep records taken in flight at selected intervals.

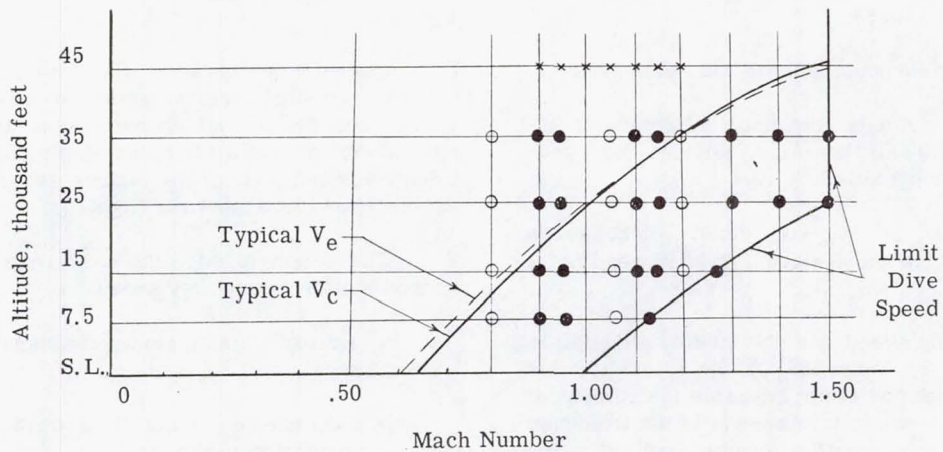

Legend:

- Symmetric & anti-symmetric sweeps
- Symmetric & anti-symmetric decays
- × Pilot control pulses (elevator & aileron or rudder)
- V_e = Equivalent airspeed, knots
- V_c = Indicated airspeed corrected for instrument and position error, knots

Figure 8. Typical Speed-Altitude Test Plan

Prior to flight a ground checkout procedure was established which accomplished the following tasks:

- a. Insured proper functioning of shaker system.
- b. Insured proper calibration of instrumentation.
- c. Insured proper operation of telemetering equipment.
- d. Set programmer parameters in accordance with desired measurements.

During flight, ground monitoring was used to:

- a. Check proper functioning of shakers, instrumentation and telemetering.
- b. Check proper positioning of pilot's shaker controls.
- c. Notify pilot if data is unsatisfactory (i.e., due to turbulence or gusts). Request repeat measurements or flying an alternative flight plan.
- d. Inform pilot of satisfactory completion of frequency sweep (i.e., to reduce test time).
- e. Estimate damping coefficients from decay records, and inform pilot either to continue testing at higher speeds or to discontinue testing until records can be analyzed in detail.

Following the analysis of data for each flight, it is necessary to re-examine the test plan and determine what modifications, if any, need to be made. Typical changes in the plan are:

- a. Decrease speed increments due to a large decrease in the damping coefficient, or alternatively, increase speed increments due to a steady increase in damping coefficients.
- b. Repeat test points due to failure of photopanel camera, which results in no speed and altitude data.
- c. Repeat test points to check scatter in data.

The main difficulties encountered in executing the flight test program were:

- a. Development problems with the airplane. Some examples are electrical power failure, malfunction of cabin pressurization system, compressor stalls, failure of afterburner to light, malfunction of fuel quantity indicator, malfunction of fire warning indicator, and a supersonic noise problem. These resulted in either aborted flights or temporary restrictions on the airplane.

- b. Meteorological problems. Examples are excessive winds preventing take-off, excessive turbulence and gusty air which would mask the response due to shaker or pilot excitation, and excessive outside air temperature which prevented achieving some of the desired speeds.

- c. Operational problems. Examples are unavailability of chase airplane or chase airplane mechanical problems, limited fuel supply, necessity of going off-base for low altitude testing, conflicts with higher priority testing, short time for taking measurements during dives at high descent velocities, and location of data reduction equipment away from test base.

The above difficulties either contributed to lengthening the duration of the flight flutter test program or decreased the reliability and accuracy of the measurements.

DATA ANALYSIS AND INTERPRETATION

The two conventional methods were used to obtain the experimental damping coefficients, namely from the response of velocity versus frequency plot, and from the response of velocity versus time (i.e., decay) plots.

A typical section of a sweep record is shown in Figure 9. Figure 10 shows a sample decay record.

A typical plot of the experimental damping versus Mach number curve is shown in Figure 11 at a 35,000 foot altitude for the second coupled anti-symmetric vibration mode. Points on this curve which are dotted were simply demonstrated and no measurements with excitation were taken. A negative damping coefficient denotes a stable system. Similar plots were obtained for all other significant vibration modes at various altitudes to demonstrate that the airplane is free from flutter over its design envelope.

The experimental results shown in Figure 11 were also compared with theoretical results. The following explanatory comments are made in connection with these theoretical calculations. Theoretical anti-symmetric mode flutter calculations at a 35,000 foot altitude were made using the lowest five anti-symmetric coupled vibration modes and for a gross weight corresponding to a 60% full fuel condition; two dimensional oscillatory aerodynamic coefficients were used in the analysis. Reference 3 contains details of these calculations. The minimum damping occurred in the second anti-symmetric coupled vibration mode with a natural frequency of 13.4 cps. Figure 11 shows this theoretical damping plotted versus Mach number -- in the transonic speed region the curve is shown dotted since no calculations were made -- at zero airspeed the structural damping

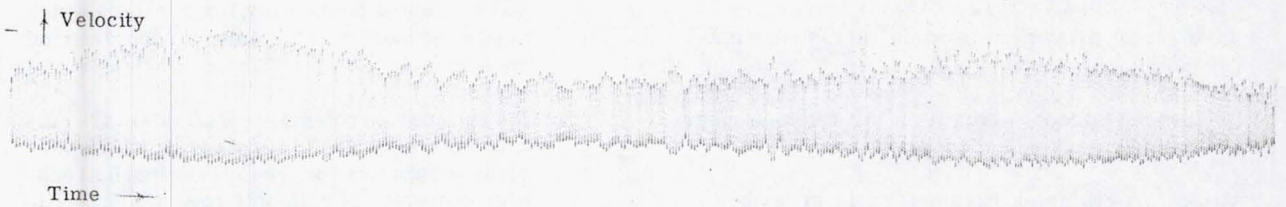

NOTES:

1. Record is for right wing pickup
2. Anti-symmetric resonant frequencies, 36 cps and 43 cps
3. $M = 1.15$, $h = 15,000$ ft.

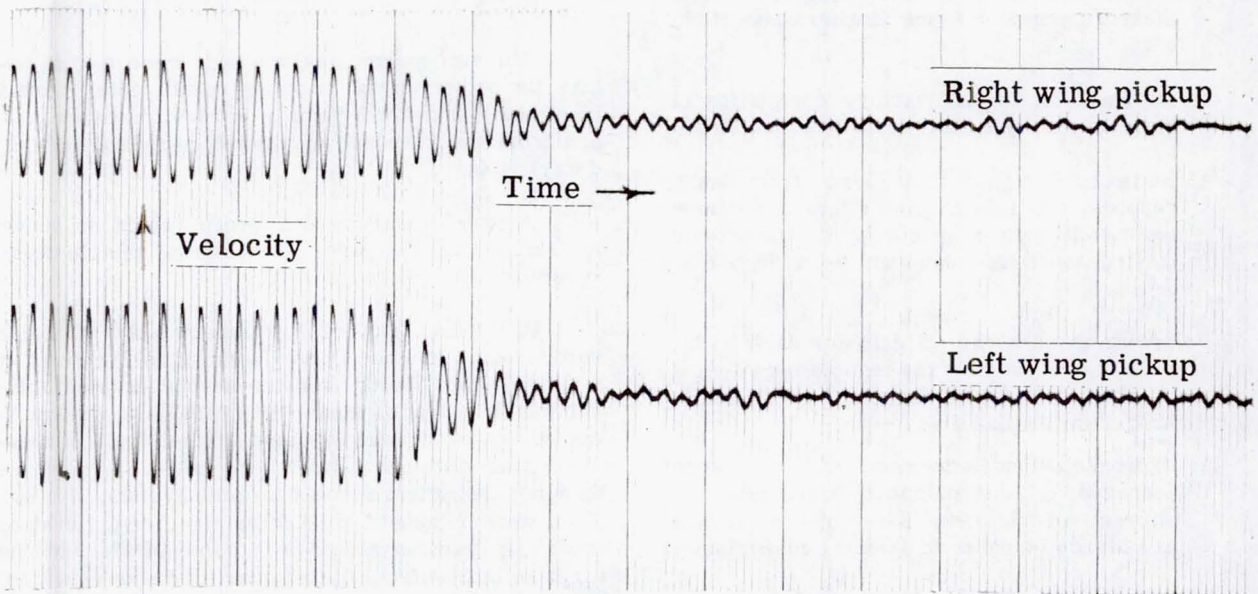

NOTES:

1. Symmetric resonant frequency = 43 cps
2. $M = 1.3$, $h = 35,000$ ft.

Figure 10. Sample Decay Record

h = 35,000 Ft.

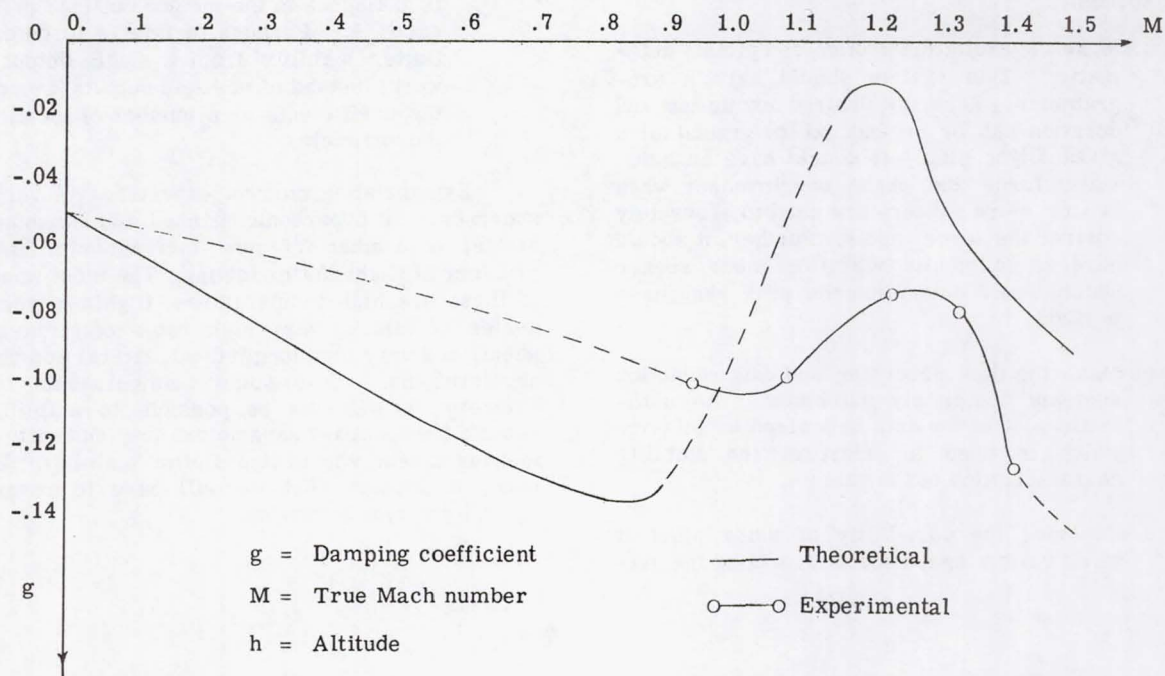

Figure 11. Comparison of Theoretical and Experimental Damping Coefficients Second Anti-Symmetric Coupled Vibration Mode

coefficient was obtained from response curves obtained during a ground vibration test. It is noted that the general shape of the experimental and theoretical plots are similar; however the actual magnitude of the damping coefficients differ by a noticeable amount.

The following problems arose in connection with analysis of the data and its interpretation:

- a. Considerable scatter was found in the damping coefficients obtained. This lead to difficulty in extrapolating the speed-damping curve to the next intended speed. Possible reasons for these apparent discrepancies were:
 1. Use of two different methods for obtaining damping factors.
 2. Transfer of energy of vibration between various portions of the airplane.
 3. Difference in mass configurations of the airplane during test.
- b. Measured damping factors varied between different pickups in the same vibrational mode.
- c. Altitude trends were difficult to establish.

d. Because excitational forces could not be made exactly equal, unsymmetric responses were obtained.

e. Because of the temperature sensitive potentiometers in the shaker programmer unit, difficulty was encountered in setting the desired frequencies for decays. Thus, less than the maximum possible response was obtained.

f. Indication of "false resonances" were obtained because of necessity of using sweep times less than theoretically desirable.

g. Masking of the lowest coupled vibration modes responses by a gust response gave an erroneous indication of damping.

RECOMMENDATIONS FOR FUTURE RESEARCH AND DEVELOPMENT

Flight flutter testing is an ever changing type of testing in which no technique may be considered perfect. As with most any type of testing, hindsight is a wonderful thing and many changes in technique and different avenues of approach present themselves as testing progresses.

Experiences with the testing discussed in this paper lead to the following recommendations for future

research and development in the field of flight flutter testing for manned aircraft flying at moderate supersonic speeds:

- a. Make the excitation system completely automatic. This system should have a programmer where the desired excitation and duration can be pre-set on the ground for a given flight plan. It should have an automatic force and phase synchronizer when two or more shakers are used to accurately control the force inputs. Further, it should have an automatic vibration mode seeker which would determine the peak responses in flight.
- b. Make the data recording and data reduction systems completely automatic. An automatic plot of the data is desired in the form which is used to interpret the stability characteristics of the vehicle.
- c. Consider the possibility of using plots of work versus speed for interpreting the sta-

bility characteristics in lieu of damping coefficient versus speed. This approach is analogous to the method outlined in Reference 4. Purpose of this is to determine flutter stability from a single output (i.e., work) instead of multiple outputs (i.e., damping coefficients at a number of locations on the vehicle).

Extrapolating current experience to very high supersonic or hypersonic manned and unmanned vehicles, a number of new factors enter into the problem of flight flutter testing. The most important of these are high temperatures, flights at very high angles of attack, very high rates of climb or descent, and very high longitudinal, lateral and vertical accelerations. For some configurations in this category it will not be possible to stabilize the vehicle for specified parameters long enough to obtain measurements concerning flutter stability. In this case, it appears that we will have to revert to a "go-no-go" type of testing.

REFERENCES

1. NACA RM 56 I 12, "A Survey and Evaluation of Flutter Research and Engineering," (CONFIDENTIAL)
2. Convair Report 56-51, "In-Flight Vibration System, Engineering and Operations Manual"
3. Convair Report ZU-8-032, "Theoretical Flutter Investigation of the F-102A Airplane", (CONFIDENTIAL)
4. N. O. Myklestad, "Vibration Analysis", McGraw-Hill Book Co.