

General Disclaimer

One or more of the Following Statements may affect this Document

- This document has been reproduced from the best copy furnished by the organizational source. It is being released in the interest of making available as much information as possible.
- This document may contain data, which exceeds the sheet parameters. It was furnished in this condition by the organizational source and is the best copy available.
- This document may contain tone-on-tone or color graphs, charts and/or pictures, which have been reproduced in black and white.
- This document is paginated as submitted by the original source.
- Portions of this document are not fully legible due to the historical nature of some of the material. However, it is the best reproduction available from the original submission.

DRA

STS Spin-Stabilized Upper Stage Study (Study 2.6) Final Report

Volume II: Technical Report

Prepared by REQUIREMENTS AND ANALYSIS OFFICE
Vehicle Systems Division

(NASA-CR-145908) SIS SPIN-STABILIZED UPPER STAGE STUDY (STUDY 2.6). VOLUME 2: TECHNICAL REPORT Final Report (Aerospace Corp., El Segundo, Calif.) 469 p CSCL 22B N76-14162
Unclas 15083
G3/16

30 September 1975

Prepared for
OFFICE OF MANNED SPACE FLIGHT
NATIONAL AERONAUTICS AND SPACE ADMINISTRATION
Washington, D. C.

Contract No. NASW-2727



Systems Engineering Operations
THE AEROSPACE CORPORATION



STS SPIN-STABILIZED UPPER STAGE STUDY (Study 2.6)

FINAL REPORT

Volume II: Technical Report

Prepared by
Requirements and Analysis Office
Vehicle Systems Division

30 September 1975

Systems Engineering Operations
THE AEROSPACE CORPORATION
El Segundo, California

Prepared for
OFFICE OF MANNED SPACE FLIGHT
NATIONAL AERONAUTICS AND SPACE ADMINISTRATION
Washington, D. C.

Contract No. NASW-2727

STS SPIN-STABILIZED UPPER STAGE STUDY
(Study 2.6) FINAL REPORT

Volume II: Technical Report

Prepared by

Requirements and Analysis Office
Vehicle Systems Division

Approved

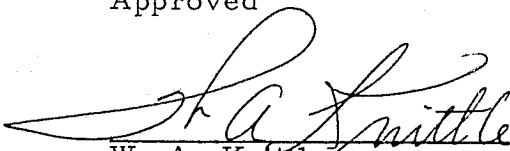

W. A. Knittle
NASA Study 2.6 Director
Requirements and Analysis Office
Vehicle Systems Division

Approved

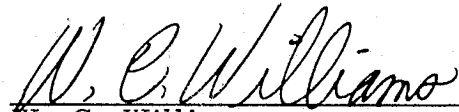

W. C. Williams
Vice President and General Manager
Vehicle Systems Division

Acknowledged



R. H. Herndon
Group Director
Advanced Mission Analysis Directorate
Advanced Orbital Systems Division



FOREWORD

This report documents The Aerospace Corporation effort on Study 2.6, STS (Space Transportation System) Spin-Stabilized Upper Stage Study, performed under NASA Contract NASW-2727 during Fiscal Years 1975 and 1976. The Aerospace effort was directed by Mr. W. A. Knittle. Mr. H. R. Gangl, Jr., Marshall Space Flight Center, and Dr. J. W. Wild, NASA Headquarters, were the NASA Study Directors for this study. Their efforts in providing technical direction throughout the duration of the study are greatly appreciated.

This volume is one of two which comprise the Final Report for Study 2.6. The two volumes are:

Volume I: Executive Summary

Volume II: Technical Report

Volume I presents a brief summary of the overall report. It includes the relationship of this study to other NASA efforts, significant results, study limitations, and suggested additional efforts.

Volume II provides a detailed description of the technical effort on the STS Spin-Stabilized Upper Stage Study. It includes a description of the modifications of NASA geosynchronous (non Com/Nav) payloads for spinning injections, sizing and accuracy studies of the spinning stage, resizing recommendations for the total NASA Space Shuttle Upper Stage Mission Model, and safety and operations analyses.

PRECEDING PAGE BLANK NOT FILMED

ACKNOWLEDGEMENTS

The Aerospace Corporation effort on Study 2.6 was supported by members of the technical staff (MTS) in various technical disciplines within the company. The contributions of the following MTS to the STS Spin-Stabilized Upper Stage Study are gratefully acknowledged:

Command and Telemetry

E. L. Tarca

Concept and Design

K. G. Ludlow
G. Yee

Controls and Electromechanical

E. G. Fotou

Cost

H. G. Campbell

Guidance and Flight Dynamics

D. W. Whitcombe
K. A. Sandoval

Mass Properties

R. T. Blake

Operations Analyses and Interfaces

W. J. Dillon
W. J. Kleinbauer

Power and Electrical

J. R. Kettler

Safety Analysis

O. W. Refling

Sizing Studies

S. R. McWaters

Solid Propulsion

E. M. Landsbaum
G. Alexandris

System Engineering

J. H. Elliott

System Integration

J. J. Donnelly, Jr.

Thermal Control

H. H. Yoshikawa

CONTENTS

FOREWORD	v
ACKNOWLEDGMENTS	vi
1. INTRODUCTION	1-1
1.1 SSUS Concept	1-3
1.2 Objectives	1-6
1.3 Relationship to Other NASA Efforts	1-6
1.4 Approach	1-7
1.5 Rockwell International SSUS/Shuttle Integration Study	1-9
1.6 Conclusions and Observations	1-9
2. SUBTASK I: GEOSYNCHRONOUS PAYLOAD MODEL DEVELOPMENT	2-1
2.1 Tug-Deployed Baseline Satellite Definitions	2-6
2.2 Basic Design Compatibility with Spin-Stabilized Operations	2-33
2.3 ELV Options for Geosynchronous Satellites	2-36
2.4 Stabilization and Control of Spin-Stabilized Satellites	2-55
2.5 Sabilization and Control of Three-Axis- Stabilized Satellites	2-62
2.6 Telemetry, Tracking, and Command	2-82
2.7 Spacecraft Electrical Power Systems	2-97
2.8 Alternatives to Tug-Deployment of Satellites	2-116
2.9 Cost Estimating Procedures	2-144
3. SUBTASK II: SSUS SIZING STUDY AND SUBTASK III: SSUS APPLICABILITY TO OVERALL NASA MISSION MODEL	3-1
3.1 Performance Sizing Analysis for the SSUS Study	3-5
3.2 Solid Rocket Motors	3-23

CONTENTS (Continued)

3.3	Angular Motion of the SSUS During PKM/AKM Burn.	3-34
3.4	Accuracy Analysis	3-49
3.5	Parametric Attitude Error Analysis	3-120
3.6	SSUS Mission Accuracy Discussion	3-140
3.7	SSUS Stage Design and Deployment Configuration	3-150
3.8	Alternate Concepts Considered	3-164
3.9	Determination of Spin System Requirements	3-170
3.10	Safety Analysis	3-174
3.11	SSUS System Cost Estimation	3-190
4.	SUBTASK IV: OPERATIONS ANALYSIS	4-1
4.1	General	4-1
4.2	Comparison of SSUS, IUS, and Tug Upper Stage Systems	4-2
4.3	Comparison of SSUS, IUS, and Tug Mission Time Lines	4-5
4.4	Comparison of SSUS, IUS, and Tug Flight Operations	4-10

FIGURES

1-1.	SSUS Geosynchronous Ascent Profile	1-4
2-1.	Task I NASA Geosynchronous Payloads	2-5
2-2.	E0-09A SEOS Inboard View, Baseline Tug Configuration	2-15
2-3.	E0-9A SEOS End View Telescope Objective, Baseline Tug Configuration	2-16
2-4.	E0-09A SEOS End View (Equipment Section) Docking Adapter, Baseline Tug Configuration	2-17
2-5.	SMS/GOES Satellite Configuration	2-20
2-6.	AS-05A ARAE Satellite Configuration	2-6
2-7.	Electrical Power Subsystem Typical Schematic	2-27
2-8.	EO-9A/AS-05A Synchronous Equatorial Satellites	2-42
2-9.	EO-57A/EO-07A Synchronous Equatorial Satellites	2-43
2-10.	Titan IIIE/Centaur D-1T Standard Centaur Fairing Envelope	2-45
2-11.	Titan IIIE with 5-m (16.7-ft) Diameter Lockheed Fairing	2-46
2-12.	Titan IIIC Universal Payload Fairing (UPLF) Envelope	2-47
2-13.	Titan IIIC with 5-m (16.7-ft) Diameter McDonnell Douglas Fairing	2-48
2-14.	Delta 2914 Payload Envelope	2-49
2-15.	Delta Staging Schematic, Three-Stage Vehicle	2-50
2-16.	Delta 2914 Configuration	2-51
2-17.	Basic Tug-Type G, N, and S System for an SMS-Type Spacecraft	2-59

FIGURES (Continued)

2-18.	Passive Nutation Damper	2-61
2-19.	Active Nutation Control System	2-63
2-20.	Basic Three-Axis Tug-Type G, N, and S System for SEOS-Type Spacecraft (EO-9A)	2-65
2-21.	Basic Three-Axis Tug-Type G, N, and S System for Radio-Astronomy-Type Spacecraft (AS-05A)	2-66
2-22.	Basic Three-Axis Tug-Type G, N, and S System for Synchronous-Meteorological-Type Spacecraft (EO-07a)	2-67
2-23.	Despun Platform (SEOS-Type)	2-76
2-24.	Active Nutation Control System Block Diagram	2-81
2-25.	Block Diagram of TT&C Subsystem (Payload Attached to SSU)	2-86
2-26.	SMS Communications Subsystem	2-87
2-27.	Illustrative Antenna Concepts	2-91
2-28.	Degradation of 10 Ohm-Cm Solar Cells	2-108
2-29.	SSUS Electrical Power System Typical Schematic	2-112
2-30.	1 MeV Equivalent Radiation Per Revolution of Transfer Orbit (125 nmi to 19,300 nmi)	2-114
2-31.	Structural Loading Due to Spin	2-120
2-32.	Spin/Despin SSUS-Launched EO-09A	2-122
2-33.	SSUS-Launched Despun EO-09A Satellite	2-123
2-34.	SSUS-Launched EO-57A Satellite	2-125
2-35.	EO-09A Inertial Data Axes	2-141
2-36.	EO-57A Inertial Data Axes	2-141
2-37.	EO-07A Inertial Data Axes	2-142

FIGURES (Continued)

2-38.	AS-05A Inertial Data Axes	2-142
3-1.	Planetary Missions Capture	3-21
3-2.	EO-57A Payload	3-35
3-3.	AS-05A Payload	3-36
3-4.	EO-09A Payload	3-37
3-5.	EO-07A Payload	3-38
3-6.	Pitch Rate History	3-42
3-7.	Yaw Rate History	3-43
3-8.	Rate Diagram	3-44
3-9.	Pitch Angle History	3-45
3-10.	Yaw Angle History	3-46
3-11.	Inertial Angle Diagram	3-47
3-12.	Attitude Pointing Error (α_s) Due to Free Spinup	3-123
3-13.	Wobble Angle Due to Free Spinup	3-125
3-14.	Estimated Time Constants of Structures and Fluids	3-127
3-15.	Initial Wobble Angle Due to Transverse Body Rate	3-129
3-16.	Final Precession Half Cone Angle for One-Hr Coast	3-130
3-17.	Final Precession Half Cone Angle for 5.25-Hr Coast	3-131
3-18.	Predicted Total Attitude Error at SRM Burnout, Perigee Motor Injection	3-133
3-19.	Predicted Wobble Angle at SRM Burnout, Perigee Motor Injection	3-134
3-20.	Predicted Total Attitude Error at SRM Burnout, Apogee Motor Injection	3-135

FIGURES (Continued)

3-21.	Predicted Wobble Angle at SRM Burnout, Apogee Motor Injection	3-136
3-22.	Attitude Error Due to Separation of Two Spinning Bodies	3-138
3-23.	Spacecraft Correction Propellant Requirement, Geosynchronous Mission	3-149
3-24.	External Spin Option	3-151
3-25.	Small SSUS Configuration	3-153
3-26.	Large SSUS Configuration	3-154
3-27.	EO-57A/SSUS Bay Arrangement	3-159
3-28.	EO-09A/SSUS Bay Arrangement	3-160
3-29.	C. G. Location Summary	3-162
3-30.	Cargo C. G. Limits (Along Y-Axis)	3-163
3-31.	SSUS Deployment with a Spin-Stabilized Satellite	3-165
3-32.	SSUS Deployment with a Three-Axis Satellite	3-166
3-33.	SSUS Deployment with Laser Alignment	3-167
3-34.	SSUS Deployment with a Retrievable Spin Table	3-168
3-35.	SSUS Planetary Four-Stage Configuration	3-169
3-36.	Spin Impulse Requirements Versus Roll Moment of Inertia	3-171
3-37.	Cold-Gas Spin System Weight and Bottle Diameter	3-173
3-38.	SSUS Unit Costs	3-218
4-1.	Estimated Baseline Tug Ground Processing Time Line.	4-6

TABLES

2-1.	NASA Geosynchronous Payload Traffic	2-3
2-2.	NASA Geosynchronous Payload Characteristics	2-4
2-3.	Task I NASA Geosynchronous Spacecraft Design Cases	2-7
2-4.	Payload Satellites Studies	2-8
2-5.	Mission Equipment for EO-09A, EO-59A, and EO-62A Satellites	2-11
2-6.	Mission Equipment for EO-57A and EO-58A Satellites	2-11
2-7.	Mission Equipment for the EO-07A Satellite	2-12
2-8.	Mission Equipment for the AS-05A Satellite	2-12
2-9.	SMS/GOES Summary Weight Statement	2-21
2-10.	EO-57A Foreign Synchronous Meteorological Satellite	2-22
2-11.	EO-07A Satellite Configuration Description	2-24
2-12.	AS-05A Satellite Configuration Description	2-26
2-13.	EO-09A Satellite Electrical Power Subsystem	2-28
2-14.	EO-57A Satellite Electrical Power Subsystem	2-29
2-15.	EO-07A Satellite Electrical Power Subsystem	2-30
2-16.	AS-05A Satellite Electrical Power Subsystem	2-31
2-17.	Propulsion and Reaction Control Subsystem	2-33
2-18.	EO-09A Satellite Thermal Control Subsystem	2-34
2-19.	EO-07A Satellite Thermal Control Subsystem	2-35
2-20.	AS-05A Satellite Thermal Control Subsystem	2-36

TABLES (Continued)

2-21.	Equipment Summary for Tug-Deployed EO-09A Satellite	2-37
2-22.	Equipment Summary for Tug- or IUS-Deployed EO-07A Satellite	2-38
2-23.	Equipment Summary for Tug- or IUS-Deployed AS-05A Satellite	2-39
2-24.	Tug-Launched Satellite Inertial Data	2-40
2-25.	Compatibility of Designated Satellites with Spin Operation on Orbit	2-41
2-26.	ELV Options Summary	2-44
2-27.	EO-90A ELV Options	2-53
2-28.	EO-07A ELV Options	2-54
2-29.	AS-05A ELV Options	2-56
2-30.	EO-57A/58A ELV Options	2-57
2-31.	Basic Tug-Type G, N, and S System Weight and Power Estimate	2-60
2-32.	Basic Three-Axis Tug-Type G, N, and S System (EO-09A) Weight and Power Estimate	2-68
2-33.	Basic Three-Axis Tug-Type G, N, and S System (AS-05A) Weight and Power Estimate	2-69
2-34.	Basic Three-Axis Tug-Type G, N, and S System (EO-07A) Weight and Power Estimate	2-70
2-35.	SSUS Dual-Spin EO-09A Mass Properties	2-71
2-36.	Steady-State Angular Velocity Error for Rotating Platform	2-77
2-37.	Steady-State Angular Velocity Errors for Rotating Platform with Momentum Wheel (Apogee Only)	2-79

TABLES (Continued)

2-38.	Satellite TT&C Characteristics/Requirements (SSPD Data Sheets)	2-83
2-39.	Satellite TT&C Characteristics/Requirements Used in Study	2-84
2-40.	EO-09A/59A/62A TT&C Subsystem (Tug, IUS, or Expendable Launch)	2-93
2-41.	EO-57A, EO-58A TT&C Subsystem (Tug, IUS, or Expendable Launch)	2-94
2-42.	EO-07A TT&C Subsystem (Tug, IUS, or Expendable Launch)	2-95
2-43.	AS-05A TT&C Subsystem (Tug, IUS, or Expendable Launch)	2-97
2-44.	TT&C Components Powered During Transfer Orbit	2-98
2-45.	Power Budget for EO-09A, EO-59A, and EO-62A Spacecraft	2-99
2-46.	Electrical Power Subsystem: EO-09A, EO-59A, and EO-62A Satellites	2-101
2-47.	Electrical Power Subsystem: AS-05A Satellite	2-102
2-48.	Electrical Power Subsystem: EO-07A Satellite	2-104
2-49.	Electrical Power Subsystem: EO-57A and EO-58A Satellites	2-105
2-50.	Solar Array Performance for Synchronous Altitude Satellites	2-107
2-51.	Solar Cell Characteristics	2-109
2-52.	Battery Performance for Synchronous Altitude Satellites	2-110
2-53.	Equivalent Radiation Environment of SSUS Spacecraft	2-115

TABLES (Continued)

2-54.	Tug Deployment Concept	2-117
2-55.	IUS Deployment Concept	2-117
2-56.	SSUS Deployment Concept	2-118
2-57.	EO-09A Satellite Modifications: Equipment and Power (Watt) Requirements in Transfer Orbit and During Injection	2-129
2-58.	EO-09A Satellite Modifications: Equipment and Weight Changes Relative to Tug-Deployed Satellites	2-131
2-59.	EO-57A Satellite Modifications: Equipment and Weight Changes Relative to Tug-Deployed Satellites	2-132
2-60.	EO-07A Satellite Modifications Equipment and Weight Changes Relative to Tug- or IUS-Deployed Satellites	2-133
2-61.	AS-05A Satellite Modifications: Equipment and Weight Changes Relative to Tug-Deployed Satellites	2-134
2-62.	EO-09A Satellite Summary Weight Statement	2-135
2-63.	EO-57A Satellite Summary Weight Statement.	2-136
2-64.	EO-07A Satellite Summary Weight Statement	2-136
2-65.	AS-05A Satellite Summary Weight Statement.	2-137
2-66.	EO-09A Satellite Mass Properties	2-138
2-67.	EO-57A Satellite Mass Properties	2-139
2-68.	EO-07A Satellite Mass Properties (No Adapter)	2-139
2-69.	AS-05A Satellite Mass Properties (No Adapter).	2-140
2-70.	Summary of Study Results, Three-Axis Stabilized Satellites (EO-09A, EO-07A, AS-05A).	2-143

TABLES (Continued)

2-71.	Summary of Study Results, Spin-Stabilized Satellite (EO-57A)	2-143
2-72.	Spacecraft Design and Cost Model, Satellite System EO-09A (Tug) (Millions of 1975 Dollars)	2-158
2-73.	Task I Payload Cost Estimate Summary (Millions of Dollars)	2-148
2-74.	Summary Cost Estimates, Δ Costs Major System Changes, IUS Expendable to SSUS Spin/Design Cases (Millions of 1975 Dollars)	2-149
2-75.	AS-05A System Cost Estimates (Millions of 1975 Dollars)	2-150
2-76.	AS-05A Δ Cost Estimates Major System Changes, IUS to SSUS (Millions of 1975 Dollars)	2-151
2-77.	EO-07A System Cost Estimates (Millions of 1975 Dollars)	2-152
2-78.	EO-07A Δ Cost Estimates Major System Changes, IUS to SSUS (Millions of 1975 Dollars)	2-153
2-79.	Conclusions From Task I Cost Estimations	2-154
3-1.	Upper Stage Payload Model	3-2
3-2.	NASA Geosynchronous Payload Characteristics	3-4
3-3.	Task II SSUS Sizing Study	3-7
3-4.	Mission and Motor Characteristics for Performance Sizing	3-7
3-5.	Ideal Motor Performance Design	3-8
3-6.	Geosynchronous Missions Motor Selection Based on Propellant Off-Load Only	3-9
3-7.	Solid Motor Characteristics for Geosynchronous Missions	3-10
3-8.	Error Analysis for Geosynchronous Mission EO-07A	3-12

TABLES (Continued)

3-9.	Adjusted Apogee Burn for Geosynchronous Mission EO-07A	3-13
3-10.	Non-Geosynchronous Earth Orbits	3-15
3-11.	Non-Geosynchronous Earth Orbits Driver Missions	3-16
3-12.	Non-Geosynchronous Earth Orbit Missions, Motor Selection Based on Propellant Off-Load Only	3-17
3-13.	Environmental Monitoring Satellite (EO-56A)	3-18
3-14.	Solid Motor Characteristics	3-19
3-15.	New Planetary Model	3-20
3-16.	Solid Rocket Motor Characteristics	3-24
3-17.	New Motors No. 1, No. 2, and No. 3 Motor Characteristics	3-25
3-18.	Spin Rocket Test Facilities	3-28
3-19.	TE-M-364 Motor Error Source Data	3-31
3-20.	Heading Error Due to Motor Burn ($\delta = 0.002$ rad)	3-43
3-21.	TRACE66 Ephemeris Output Key	3-50
3-22.	Coast Orbit and Apogee Errors.	3-74
3-23.	Coning and Heading Errors (assumed equal) Resulting from Offsetting Moment (θ_M) and Tip-Off Rates (θ_r) During the Initial and Final Phases of Each Burn	3-73
3-24.	SSUS Geosynchronous Transfer Orbit Accuracy (3σ) 296.23 \times 35,786 km (160 \times 19,323 nmi) Inclination 26.15 deg	3-141
3-25.	SSUS Injection Error Analysis	3-142
3-26.	Geosynchronous Injection Accuracies	3-143

TABLES (Continued)

3-27.	EO-57A/SSUS, Delta 2914, and Atlas Centaur Geosynchronous Transfer Orbit Accuracy Comparison (3σ)	3-144
3-28.	EO-57A/SSUS and Delta 2914 Accuracy Comparison	3-145
3-29.	NATO III Fuel Budget	3-147
3-30.	ACS Propellant Budget	3-148
3-31.	Hazardous Situations	3-176
3-32.	Work Breakdown Structure (Abbreviated)	3-191
3-33.	Solid Rocket Motor Options	3-194
3-34.	Minimum Avionics Option	3-195
3-35.	Complete Avionics Option	3-196
3-36.	Geosynchronous Family, SSUS Two-Stage System, Minimum Avionics, Satellite-Dependent Cost Estimates	3-198
3-37.	EO-57A/SSUS Two-Stage System Only, Minimum Avionics, Satellite-Dependent Cost Estimates	3-200
3-38.	Geosynchronous Family, SSUS Two-Stage System, Complete Avionics, ACS, Satellite-Independent Cost Estimate	3-202
3-39.	EO-57A/SSUS Two-Stage System Only, Complete Avionics, ACS, Satellite-Independent Cost Estimate	3-204
3-40.	Geosynchronous Family SSUS System, PKM Only, Minimum Avionics, Satellite-Dependent Cost Estimate	3-206
3-41.	EO-57A/SSUS Single-Stage System, PKM Only, Minimum Avionics, Satellite-Dependent Cost Estimate	3-209
3-42.	SSUS Cost Summary	3-211

TABLES (Continued)

3-43.	SSUS Two-Stage, Minimum Avionics, Satellite-Dependent Unit Costs	3-212
3-44.	SSUS Two-Stage, Complete Avionics, Satellite-Independent Unit Costs	3-214
3-45.	SSUS Single-Stage, PKM Only, Minimum Avionics, Satellite-Dependent Unit Costs	3-216
4-1.	SSUS Mission Time Line for Satellite Delivery	4-7
4-2.	Tug Mission Time Line for Satellite Delivery	4-8
4-3.	Expendable IUS Mission Time Line for Satellite Delivery	4-9
4-4.	Major Conclusions of Flight Operations Review	4-11
4-5.	Conclusions from Reference 1	4-12
4-6.	EIUS/Orbiter Operational Interactions	4-18
4-7.	EIUS Checkout Analysis Ground Rules and Assumptions	4-19
4-8.	EIUS On-Orbit Checkout Philosophy	4-21
4-9.	EIUS Checkout Requirements Summary (Ref: SR-IUS-100, July 1974)	4-22
4-10.	EIUS Major Component Checkout/Monitoring Summary	4-25
4-11.	Orbiter Software Functions To Support EIUS	4-26
4-12.	Ground Network Functions During EIUS Operations	4-27
4-13.	Launch Site Support Functions During EIUS Operations	4-28
4-14.	Shuttle Orbiter Control Center Functions During EIUS Operations	4-28
4-15.	Orbiter Functions During EIUS Operations	4-29

TABLES (Continued)

4-16.	Spacecraft Operations Control Center Functions During EIOUS Operations	4-30
4-17.	Spacecraft Functions During EIOUS Operations	4-31
4-18.	EIOUS Operations Center Functions During EIOUS Operations	4-32
4-19.	EIOUS Operations Functions	4-33

SECTION 1

INTRODUCTION

The Space Transportation System (STS) will replace the present National Launch Vehicle family of expendable launch vehicles (ELVs) in the early 1980's for the transportation of satellites and other space payloads. As presently configured, the STS includes a booster stage, an Orbiter, and an upper stage system to be carried within the Orbiter. Utilization of the STS to achieve high-energy orbits is dependent upon the capabilities of the upper stage system provided. The ultimate system will be the full-capability, reusable Space Tug, but it is not scheduled for introduction until 1984.

Prior to the availability of the Space Tug, an Interim Upper Stage (IUS), a modified version of an existing expendable upper stage, will be used. A number of IUS options are presently under study including expendable, reusable, liquid propellant, and solid propellant configurations in several sizes and with varying capabilities and characteristics. However, all of the options being considered feature inertial guidance and three-axis stabilization.

Other alternatives and options to an upper stage system have been postulated. These alternatives generally are satellite or payload provided ("program peculiar") and in some cases may involve simple extensions of major propulsive capability already present in the satellite and the use of inherent satellite navigation and control capabilities to perform the orbit transfers required of an upper stage. One such proposed alternative is an extension of the apogee kick motor (AKM) propulsion system utilized in some satellites for final injection into orbit at the apogee of a transfer orbit. The addition of a perigee kick motor (PKM) propulsion system to inject the satellite into the required transfer orbit has been utilized on ELV boosters and could also be utilized with the STS Orbiter. Thus, a satellite/AKM/PKM system might conceivably avoid the requirement for a general purpose upper stage system. For simplicity and low cost, satellite/AKM/PKM systems

have usually employed spin stabilization. The pursuit of this concept has led to the NASW -2727 Task 2.6 STS Spin-Stabilized Upper Stage (SSUS) Study.

The term Spin-Stabilized Upper Stage is utilized in this report as generic terminology to describe a system deployed from the Orbiter consisting of a PKM and AKM (which may be integral or nonintegral with the satellite) having primary spin stabilization and solid rocket propulsion. The term in some usage may include the satellite, especially where the satellite is the controlling part of the system. The SSUS could also be defined as the PKM system only, referenced to a satellite with an integral AKM system; however, this study task did not specifically include any such situations. The primary propulsion systems involved need not be limited to solid rocket systems, especially in the AKM, but the solid rocket systems were a ground rule element of the study task and liquid systems were not considered.

Due to the SSUS dependence upon the satellite subsystems and the dynamic stability involvement caused by spin stabilization, the SSUS design is a function of the particular satellite design with which it is integrated. The satellites in the NASA mission model encompass the complete spectrum of mission requirements, orbital characteristics, size, and stabilization techniques. The spin-stabilized satellites lend themselves to the SSUS system readily, while the satellites normally operating in a three-axis mode on orbit require extensive modification.

A key element of the SSUS concept is that the Orbiter supplies initial position and pointing guidance and navigation to the SSUS. The Orbiter-SSUS deployment and spin stabilization must maintain these initial conditions so that the subsequent mission events may provide a useful and accurate final satellite orbit. The remainder of the SSUS mission after deployment from the Orbiter and the spin-stabilized PKM injection burn into a transfer orbit is under the command and control of a ground tracking network. The ground tracking network establishes the ephemeris of the transfer orbit; determines the orbital errors and satellite inertial attitude; calculates the required satellite/AKM attitude, pointing, and apogee velocity vector; and issues the required commands in real time to execute the apogee burn injection into the final orbit with minimum errors.

A large number of potential options, problems, and solutions appeared in the detailed study of the SSUS. Some of these are obvious characteristics, some were appreciated only as they were encountered in the course of study, and some depend upon decisions as to applications. The SSUS appears to be a technically feasible approach for the earth orbit missions, particularly for spin-stabilized satellites. For some three-axis stabilized satellites, the changes required for SSUS integration may be uneconomical. The planetary missions are more difficult and may prove to be impractical for the SSUS. The SSUS is thus an alternative for portions of this mission model if not the entire model, but its economic viability depends on the characteristics and costs of the other STS upper stage options.

1.1 SSUS CONCEPT

The general concept of the SSUS is illustrated in Figure 1-1, SSUS Geosynchronous Ascent Profile. The nominal geosynchronous mission begins with Orbiter injection into a 296.32-km (160-nmi) circular orbit inclined at 28.4 deg. Upon completion of checkout and navigation functions, the satellite and SSUS are deployed in a spin-stabilized mode by the Orbiter with initial position and attitude of the SSUS established by the Orbiter. The deployment system, through use of the Orbiter navigation system augmented with a deployment-system-mounted star sensor, aligns the SSUS with the required perigee velocity vector. After a safe-distance retro maneuver by the Orbiter, the SSUS and Orbiter coast in the parking orbit to the appropriate nodal crossing at which time the Orbiter issues a real-time arming and firing command sequence through the rf command link to the satellite to fire the SSUS perigee kick motor (PKM) and inject the SSUS into a $296.32 \times 35,786$ km (160 \times 19,323 nmi) 26.15-deg inclined geosynchronous transfer orbit. Due to the unstable spin inertia to transverse inertia ratios of the SSUS during the parking orbit and transfer orbit coast periods, an active nutation control system must be installed in the satellite to maintain the nutation or coning angle at minimal values between 0.5 and 1.0 deg.

After injection into the geosynchronous transfer orbit, the command and control of the SSUS is handed over from the Orbiter to the

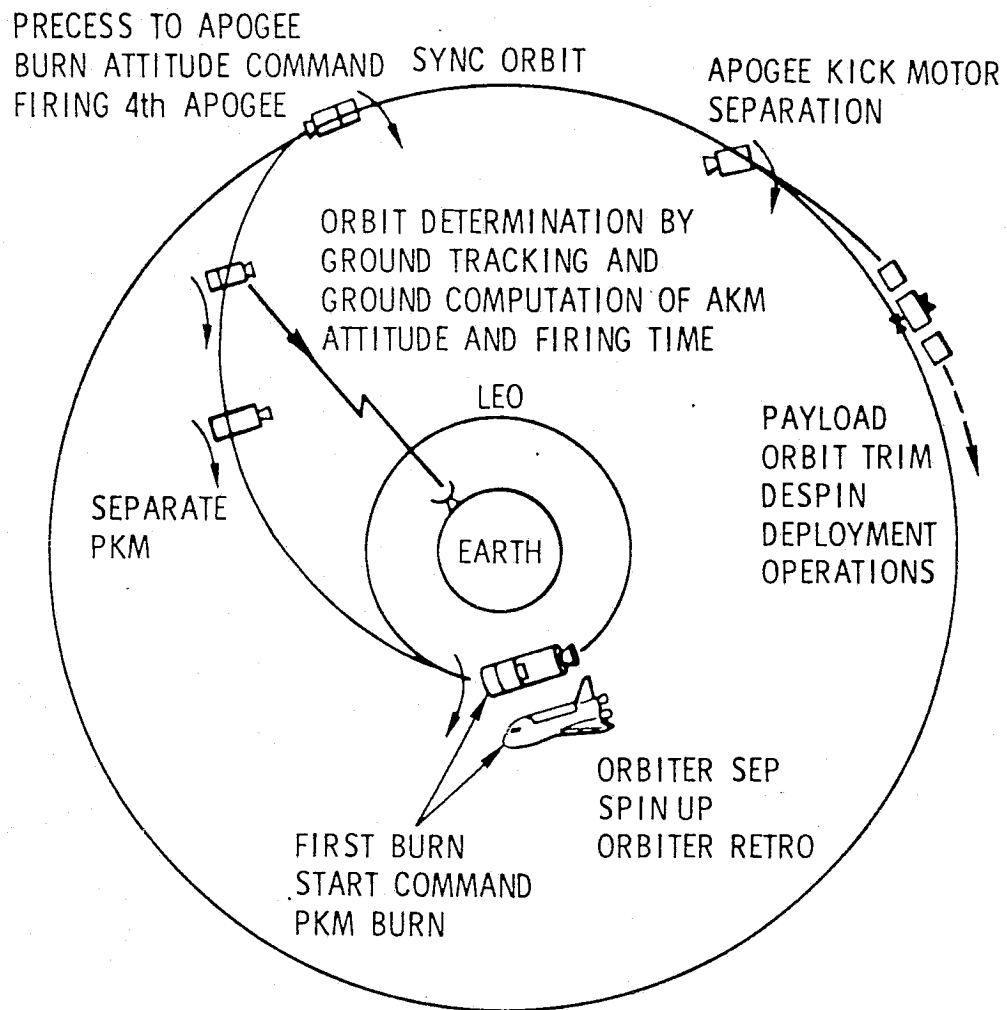
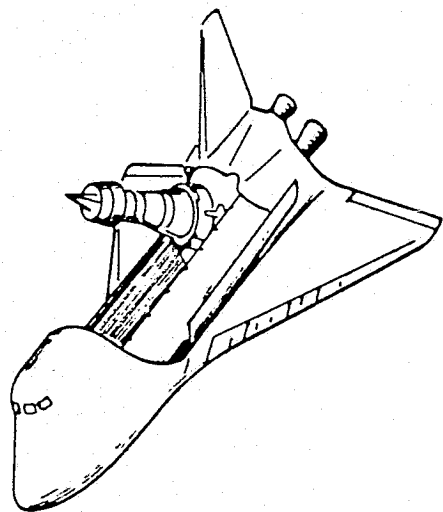

Figure 1-1. SSUS Geosynchronous Ascent Profile

appropriate ground station network, in this study assumed to be the Space Tracking and Data Network. The SSUS remains in the 10.5-hour period transfer orbit for several revolutions while the satellite telemetry, tracking, and command (TT&C) link is tracked by the ground station network. The satellite telemetry provides SSUS attitude data from earth and sun sensors mounted on the satellite. Successive coarse and fine attitude correction commands are issued real time to the satellite to precess the SSUS to the desired apogee velocity vector attitude for AKM firing. The ground station network establishes the transfer orbit ephemeris and orbit errors, computes the AKM velocity vector attitude, and designates the time of firing to produce minimum final orbit error after injection. When this has been accomplished (a period of hours or days), the ground station network issues a series of real-time commands to arm and fire the AKM system on the selected apogee (anywhere from the first to the eleventh or later; the fourth apogee is assumed in this study).

After AKM burn and injection into the nominal 35,786-km (19,323-nmi), 0-deg inclined circular geosynchronous equatorial orbit, the ground station network issues a series of commands to initiate normal orbital operations. The actual injection is into a drift orbit with a velocity deficiency, such as 15.25 m/sec (50 ft/sec) -5.5 deg/day to allow the satellite to be positioned at the final longitude by attitude control system (ACS) thruster firings. The initial commands after AKM burn arm and fire the separation system to jettison the AKM stage of the SSUS (may not be required for an internal integrated satellite AKM). Subsequent to AKM jettison, satellite attitude sensor data are evaluated by the ground stations, and commands are issued to precess the satellite to the desired attitude (for spin-stabilized geosynchronous satellites, the solar array drum is erected perpendicular to the orbit plane). For satellites which are to be designed to operate on orbit in a three-axis stabilized mode, commands are issued to despun the satellite using satellite tangential (ACS) thrusters and switch over to three-axis stabilized control. An acquisition sequence is then commanded for the

satellite sensors to acquire the earth, sun, and/or stars, depending on the satellite-pointing requirements and reference selections. Commands are issued to deploy solar arrays, antennas, and other stowed satellite empenages.

The ground station network now tracks the satellite to determine the final orbit ephemeris and errors and issues commands for thruster firing to correct the orbit errors, attitude errors, and drift rate. By iterations of the tracking and orbit adjustments, near-perfect final orbit is achievable with the satellite on final station. These maneuvers require approximately 90 m/sec (300 ft/sec) equivalent delta velocity capability in the satellite ACS system, including approximately 45 m/sec (150 ft/sec) for SSUS injection error correction. For a 362.88-kg (800-lb) satellite, this requires about 13.5 kg (30 lb) of hydrazine ACS propellant out of a total satellite propellant budget of perhaps 27 kg (60 lb) of propellant.

1.2 OBJECTIVES

Study 2.6 had two objectives. The first objective was to provide transportation systems and operations data for conceptual designs of spinning solid propellant stages for geosynchronous payloads. This required not only a study of propulsive spinning upper stage systems and their related aspects to perform the geosynchronous missions, but also analysis of selected geosynchronous payloads to evaluate the impact to the payloads of such spinning stages.

The second objective was to review the applicability of these stages to the 1981-1991 NASA Mission Model and determine the subset to which the spinning solid propellant stage is a low-cost alternative to the IUS. Full accomplishment of this objective requires an assessment of the SSUS and IUS on an equal basis which is difficult since the SSUS is a new and relatively undefined system concept while the IUS has had major contracted studies of options evolving successive concepts in considerable depth of detail.

1.3 RELATIONSHIP TO OTHER NASA EFFORTS

The FY 1975 Study 2.6 made extensive use of other NASA-contracted studies and activities. The Space Shuttle Payload Description Activity documents, JSC 07700 Volume XIV, Space Shuttle System Payloads Accommodations, and MSFC 68M00039, Baseline Space Tug, documents were fundamental to the Task 2.6 studies. The IBM IUS/Tug

Orbital Operations and Mission Support Study and Martin Marietta Tug Fleet and Ground Operations Schedules and Controls reports were studied for SSUS operations comparisons. Numerous other NASA sources were also contacted formally and informally in the course of the study due to the interrelationship with the entire STS activity.

Considerable advantage was taken of USAF/SAMSO (Space and Missile Systems Organization) IUS activities in support of the NASA portion of the IUS mission model, and the SR-IUS-100 specification was utilized as representative of a baseline IUS. In addition, a SAMSO-funded Spinning Solid Upper Stage/Shuttle Integration Study, contract NAS9-14000, Rockwell International Space Division, utilized preliminary data from the SSUS Task 2.6 study and provided useful data in return. This study is discussed in greater detail later in this section. In brief, the Rockwell International study concluded, as does Study 2.6, that spin up of satellites attached to the Orbiter is feasible using a spin table and recommended further study of detail design trades. Advantage was also taken of the five SAMSO-funded IUS studies during the performance of Study 2.6.

1.4 APPROACH

The study approach followed the pattern of the four major subtasks outlined in the statement of work. Subtask I, Geosynchronous Payload Model Development, was a major self-contained task. Major Subtasks II and III, SSUS Sizing Study and SSUS Applicability to the Overall NASA Mission Model, respectively, were interrelated tasks which, due to the technical disciplines involved, were accomplished together, phasing Subtask II into Subtask III effort. Subtask IV, Operations Analysis, the smallest effort, depended on concepts generated in the other three subtasks and occurred last during the period of performance. Emphasis throughout the study was on definition of characteristics unique to the SSUS in comparison to the Tug/IUS.

The Subtask II SSUS Sizing Study was originally planned as a parallel task with Subtask I. The sizing was to be based on a definition of the geosynchronous communication/navigation payloads provided by NASA. It developed that it was not feasible to provide these data so that about half way through Subtask I, agreement was reached to proceed on the basis of the geosynchronous non-communication/navigation payload data being developed in Subtask I. The non-communication/navigation payload data spanned the total weight range of the geosynchronous mission model and included both

spin-stabilized and three-axis stabilized satellites, thus making a representative sample of payloads. However, none of these satellites provided an opportunity to evaluate the SSUS with an integral spacecraft AKM design which was a feature of the original plan to use the communication/navigation payloads.

The sizing study proceeded with the matching of existing and current technology solid propellant rockets of low length-to-diameter ratio configuration with the required perigee and apogee velocity vector total impulse requirements for each satellite. Idealized motors, new and existing motors with propellant off-loading, energy management techniques, and ballasting were examined. From these data, motor design combinations capable of capturing the mission model were selected. These data were examined for the balance of the geosynchronous, other earth orbit missions, and planetary missions to reevaluate sizing for capture of the entire mission model as revised by the April 1975 Marshall Space Flight Center (MSFC) Upper Stage Payload Model.

Orbital accuracy studies were initiated with a quick simplified analysis combining an established and estimated error budget without AKM velocity vector biasing to reduce final orbit errors. These data were available as a conservative measure of accuracy for the Subtask I Geosynchronous Payload Analysis. Subsequently, a more detailed analysis was performed utilizing established Orbiter position and rate data, a more complete assessment of error sources/values, and an AKM apogee velocity vector bias (ground-guided burn) to null out errors accumulated in the transfer orbit. These accuracy analyses included heading errors and velocity losses obtained from dynamic stability computer simulations using the estimated moments of inertia, center of gravity locations and offsets, and rocket motor thrust misalignments based on the Subtask I satellite data, Subtask II motor sizing, and stage design arrangements. These simulations analyzed the dynamic pointing errors, coning angles, and final heading errors for the changing characteristics of the system during the motor burns.

The SSUS design as an upper stage vehicle containing solid rocket motors, structure, separation systems, antennas, and spin and deployment mechanisms was analyzed in several concepts. The feasibility of both spin tables mounted in the Orbiter and free-spin external deployment were examined. The mission sequences of events and interface relationships

were defined between the SSUS, Spacecraft, and Orbiter. A safety analysis of these design and deployment feature interfaces and operations was conducted to evaluate any additional safety hazards peculiar to the SSUS over and above those identified for more conventional satellite, Tug, and IUS concepts.

The SSUS system cost segments and elements were estimated using the SAMSO IUS evaluation data bank and the IUS assessment team. A "bottom up" cost estimating approach tied to the development of specific systems, estimates of tasks, material costs, manpower requirements, and schedules thus underlies the total cost estimates for the SSUS systems and options.

The Subtask IV Operations Analyses were the smallest effort in Task 2.6 and compared SSUS ground and flight operations and characteristics with generic Tug/IUS operations and characteristics. The MSFC-supplied Martin Marietta Corporation Tug Fleet and Ground Operations Final Report and the IBM IUS/Tug Orbital Operations and Mission Support Study Final Report were utilized as baselines for the Tug/IUS comparison to SSUS.

1.5 ROCKWELL INTERNATIONAL SSUS/SHUTTLE INTEGRATION STUDY

During the course of the NASA Task 2.6 study, USAF/SAMSO funded the Rockwell International Space Division on Contract NAS9-14000 CCA 143 to perform a SSUS/Shuttle Integration Study using concept and mass properties data from Task 2.6. The Rockwell International study was reported in Space Division briefing SD75-SH-0165. This study considered the spin-table deployment using Orbiter navigation and stabilization with an auxiliary star tracker mounted on the spin table to deploy a large SSUS from the Orbiter. The results were in general agreement with the Task 2.6 study regarding the feasibility of the concept and provided more detail on the SSUS/Orbiter interface as well as a different approach to spin-table design.

1.6 CONCLUSIONS AND OBSERVATIONS

The Task 2.6 study results indicate that the concept of a spin-stabilized solid rocket upper stage for the STS is a technically feasible concept and may be economically viable for a portion of the mission model,

depending on the competing system options. Specific conclusions. Specific conclusions and observations are outlined in the following paragraphs.

1.6.1 Technical Impacts on Satellites

Requirement for spin-stabilized transfer at 45 to 100 rpm, 5-g centripetal acceleration, symmetry desirable, balance and ballast CG location ≤ 2.54 mm (0.1 in.) to spin axis.

Active nutation control system required with 22.24-N (5-1b) thruster control.

Addition of earth and sun sensors for spin functions.

Increased ACS propellants for nutation, precession, despin (of three-axis), and greater orbital errors.

Command interfaces with Orbiter, SSUS, and ground station networks and omni-antenna requirements.

Longer duration missions due to transfer orbit tracking of several revolutions for AKM firing.

Requirement for partial satellite power up and partial power from folded solar arrays.

1.6.2 Cost Impacts on Satellites

For new design, three-axis stabilized, expendable spacecraft, spin/despin SSUS increases RDT&E and unit costs compared to Tug, IUS, and launch vehicle expendable designs due to added stabilization and controls, sensors, and functions.

- a. Cost increases \$2.2 million to \$5.6 million RDT&E
- b. Cost increases \$0.8 million to \$1.5 million unit cost

Cost and changes influenced by capability of basic spacecraft equipment.

For spin-stabilized spacecraft such as EO-57A and current SMS/GOES, SSUS design and cost effects are minor.

- a. RDT&E costs increase up to \$0.2 million
- b. Unit costs increase up to \$0.07 million

1.6.3 Mission Capture

Feasible to capture geosynchronous and other earth orbit missions.

Two new solid rocket motors (1,800 and 6,000 kg) and three existing motors capture geosynchronous missions.

A third new motor (9,000 kg) and two more existing solid rocket motors capture the entire model (except PL-12A and PL-14A) from a propulsion energy standpoint.

Planetary mission capture requires further study in mission design, stability, and accuracy to establish full feasibility.

1.6.4 Orbit Accuracy

For geosynchronous missions, SSUS accuracy is equal to present Delta ELV.

SSUS accuracy is inferior to Tug and IUS inertial guidance; SSUS errors are three times greater.

Satellites can correct SSUS injection errors utilizing hydrazine ACS equivalent to slightly more than 2 percent of the satellite weight. Best accuracy is achieved with optimum propellant load solid motors, and optimum ΔV trajectory design.

Accuracy and stability intimately related to mass properties, balance, and alignments of spacecraft, AKM, and PKM.

1.6.5 Design

Spin-table deployment with table-mounted star sensors and Orbiter navigation.

Geosynchronous total model can be met with a large 9,000-kg (20,000-lb) gross weight, two-stage system (AKM/PKM) in single or dual (forward and aft) installation and a small 3,200-kg (2,000-lb) gross weight, two-stage system in a 2×2 vertical Orbiter bay arrangement (2 forward, 2 aft).

Multiple-payload Orbiter flights utilizing multiple SSUSs.

Multiple payloads on a single SSUS are limited due to requirement requirement for CGs to be on spin axis.

1.6.6 Safety

Spinning hazards well understood; much history.

Deployment design must incorporate safety considerations, redundancy, fail-safe modes, and abort modes.

Thorough dynamic separation analyses required.

Inadvertant motor ignition commands and other hazards similar to any upper stage.

1.6.7 Flight and Ground Operations

Orbiter SSUS cradle/spin table installation simple.

Orbiter RF control of SSUS through PKM burn.

Satellite Operations Control Center/Ground Tracking Station Network control of SSUS from PKM burnout through final orbit insertion.

Time line within established Orbiter/IUS/Tug plans.

Ground operations simple; balance, alignment, and assembly facility similar to present Delta Spin-Balance Facility required.

1.6.8 Cost Estimates in FY 1976 Dollars

Delta-class SSUS system development costs for 250- to 500-kg (550- to 1,100-lb) payloads are \$35.8 million, and RDT&E unit costs are \$0.8 million.

Large and small SSUS system for entire Geosynchronous Mission Model with two sizes of spin table costs \$65.8 million for RDT&E; large SSUS unit costs are \$1.05 million and small SSUS unit costs are \$0.81 million.

PKM-only Delta-class SSUS RDT&E costs are \$34.1 million; unit costs are \$0.56 million.

Full avionics option addition to SSUS adds approximately \$20 million RDT&E costs and \$1.6 million per unit to above costs.

1.6.9 Rockwell International Spinning Solid Upper
Stage/Shuttle Integration Study Conclusions

Spin up of satellites attached to Orbiter is feasible and can be done safely.

Baseline concept (spin table/cradle/star sensor) is one method to perform task.

Mid-body spin up is viable option.

Multi-satellite deployment can be accomplished with special designs.

Rough-order-of-magnitude costs are \$8.0 million for spin table, \$7.9 million for cradle, and a \$15.9 million total in FY 1976 dollars.

1.6.10 Overall Task 2.6 Conclusion

SSUS concept technically feasible.

SSUS as accurate as Delta.

Appears more attractive for Delta-class payloads portion of the Geosynchronous Mission Model.

SECTION 2

SUBTASK I: GEOSYNCHRONOUS PAYLOAD MODEL DEVELOPMENT

Subtask I, Geosynchronous Payload Model Development, was baselined to the study of the geosynchronous payloads (excluding communication/navigation payloads) contained in the NASA-MSFC Preliminary SSPD Payload Description, Volume I, Automated Payloads, Level B Data, July 1974, as revised by additional Preliminary Information, Level B Data Sheets, supplied for Payload Numbers AS-05A, EO-07A, EO-59A, and EO-62A. Other payloads studied were EO-09A, EO-57A, and EO-58A. The study thus encompassed seven payloads; the remaining eight payloads in the model were communication/navigation payloads. The seven payloads were analyzed for their design characteristics when deployed by an ELV, by the Orbiter using a generic Space Tug, by a generic IUS, and by a spin-stabilized solid rocket upper stage (SSUS). These seven payloads all required an external apogee kick motor (AKM) system. Options included serviceable and retrievable spacecraft designed for use with the Tug and expendable satellite designs. Since this task preceded the SSUS Sizing Study, design assumptions for the SSUS characteristics were necessary, and conservative assumptions were made. Study and understanding of estimated satellite impacts influenced the subsequent SSUS design, and a second look at the actual satellite impacts following definition of SSUS characteristics and options would appear necessary at a future time.

The NASA payload descriptions for geosynchronous payloads are those of Space-Tug-launched satellites, and the design approach was to detail their characteristics to the extent necessary to provide a baseline design understanding. Subsequent analyses considered those design modifications brought about by the upper stage options. Modifications for the

spin-stablized satellites were less than for three-axis satellites, while three-axis satellite modifications to adapt to the SSUS were extensive in comparison with the three-axis Tug/IUS stages.

The principal outputs of the Subtask I payload study were data on the technical modification for the upper stage options and cost estimation for those changes. A modified System Cost/Performance Analysis Cost Model II was utilized to estimate the RDT&E and unit costs of the satellite design options. The model emphasized discrete equipment additions/modifications to provide a relative cost estimate between options as well as an estimate of total costs. Total costs include a throughput cost allowance for mission equipment on each satellite which probably made total satellite program costs a less precise figure; however, the objective of defining cost differences between transportation options was unaffected.

The NASA 1981 - 1991 Geosynchronous Payload Model as extracted from the NASA Space Shuttle Payload Description Activity (SSPDA) documents is shown in Tables 2-1 and 2-2. The SSPDA Level A data were utilized for initial screening purposes, but data were primarily obtained from the more detailed SSPDA Level B document and additional preliminary SSPDA Level B data sheets supplied by MSFC.

The Statement of Work directed the Subtask I analyses to consider only the non-communications and navigation (non-Com/Nav) payloads in the mission model. The seven non-communications/navigation payloads are identified in Tables 2-1 and 2-2. The seven non-communication/navigation geosynchronous satellites consisted of four designs since the EO-09A Synchronous Earth Observatory Satellite (SEOS), the EO-59A Geosynchronous Earth Resources Satellite (GERS), and the EO-62A Foreign Synchronous Earth Observatory Satellite (FSEOS) were represented by identical data. The satellites ranged in SSPDA weight from 1474 kg (3250 lb) to 257 kg (566 lb) and included both three-axis and spin-stabilized design for on-orbit operation. Figure 2-1 illustrates the four basic satellite designs and their major features.

Note: Some variations in weights quoted for the satellites will be found throughout this report due to the necessity of performing concurrent tasks utilizing available weight estimates prior to the determination of final weight estimates. However, these variations do not materially affect the analyses and results.

Table 2-1. NASA Geosynchronous Payload Traffic

PAYLOAD CODE	NAME	80	81	82	83	84	85	86	87	88	89	90	91	TOTAL
•EO-57-A (NN/D-9)	FGN. SYNC. MET. SAT.		1	1		1		1		1		1		6
•EO-58-A (NN/D-10)	GEO OPER ENVIRON SAT		1	1	1		1		1	1	1		1	8
CN-52-A (NN/D-2A)	DOMSAT A	1	2	2	1									6
CN-55-A (NN/D-4)	TRAFFIC MANAGEMENT	2	2	1	1	1		1		1		1		10
CN-56-A (NN/D-5A)	FOREIGN COMM. A		1	1	1	1	1	1	1	1	1	1	1	11
CN-54-A (NN/D-3)	DISASTER WARNING		1	1			1					1		4
CN-58-A (NN/D-2C)	DATA RELAY SAT				3					3				6
CN-59-A (NN/D-6)	COMM. R & D						1			1		1		3
•EO-07-A (EO-7)	SYN. MET. SAT								1					1
•AS-05-A (AST-1C)	ADV. RAD. AST. EXP.								1					1
CN-51-A (NN/D-1)	INTELSAT	3			2	3	2	2			2	3	2	19
CN-53-A (NN/D-2B)	DOMSAT B					1	1	2	2	3	2	2	1	14
•EO-09-A (EO-4)	SYN. EARTH OBS.				1		1		2		2		2	8
•EO-59-A (NN/D-12)	EARTH RESOURCES									2		2		4
•EO-62-A (NN/D-13)	FGN. EARTH RES.									1	2		1	4
		6	8	7	10	7	8	7	8	14	10	12	8	105

• Task 2.6 Task I Payloads

Table 2-2. NASA Geosynchronous Payload Characteristics

Payload Code	Name	Weight		Length		Diameter		Stabilization
		kg	lb	m	ft	m	ft	
•EO-57-A (NN/D-9)	FSMS	257	566	3.14	10.3	1.91	6.27	Spin 100 rpm
•EO-57-A (NN/D-10)	GOES	257	566	3.14	10.3	1.91	6.27	Spin 100 rpm
CN-52-A (NN/D-2A)	DOMSAT A	262	577	3.20	10.5	2.20	7.22	Spin 60 rpm
CN-55-A (NN/D-4)	TMS	298	658	1.58	5.18	3.88	12.73	3-Axis
CN-56-A (NN/D-5A)	FCS	310	679	2.36	7.74	1.60	5.25	3-Axis
CN-54-A (NN/D-3)	DWS	582	1284	5.12	16.8	1.40	4.59	3-Axis
CN-58-A (NN/D-2C)	DOMSAT C	865	1908	3.69	12.1	2.18	7.15	Spin (TBD)
CN-59-A (NN/D-6)	COMM R&D	956	2108	6.00	19.68	3.40	11.15	3-Axis
•EO-07-A (EO-7)	ASMS	1247	2750	2.91	9.55	4.21	13.81	3-Axis
•AS-05-A (AST-1C)	ARAE	1202	2650 (pair)	2.47	8.1	4.24	13.91	3-Axis
		601	1325 (single)					
CN-51-A (NN/D-1)	INTELSAT	1472	3245	2.70	8.86	2.50	8.2	3-Axis
CN-53-A (NN/D-2B)	DOMSAT B	1472	3245	2.70	8.86	2.50	8.2	3-Axis
•EO-09-A (EO-4)	SEOS	1474	3250	5.20	17.06	4.30	14.11	3-Axis
•EO-59-A (NN/D-12)	GERS	1474	3250	5.20	17.06	4.30	14.11	3-Axis
•EO-62-A (NN/D-13)	FSEOS	1474	3250	5.20	17.06	4.30	14.11	3-Axis

•Task 2.6 Task I Payloads

2-4

ORIGINAL PAGE IS
OF POOR QUALITY

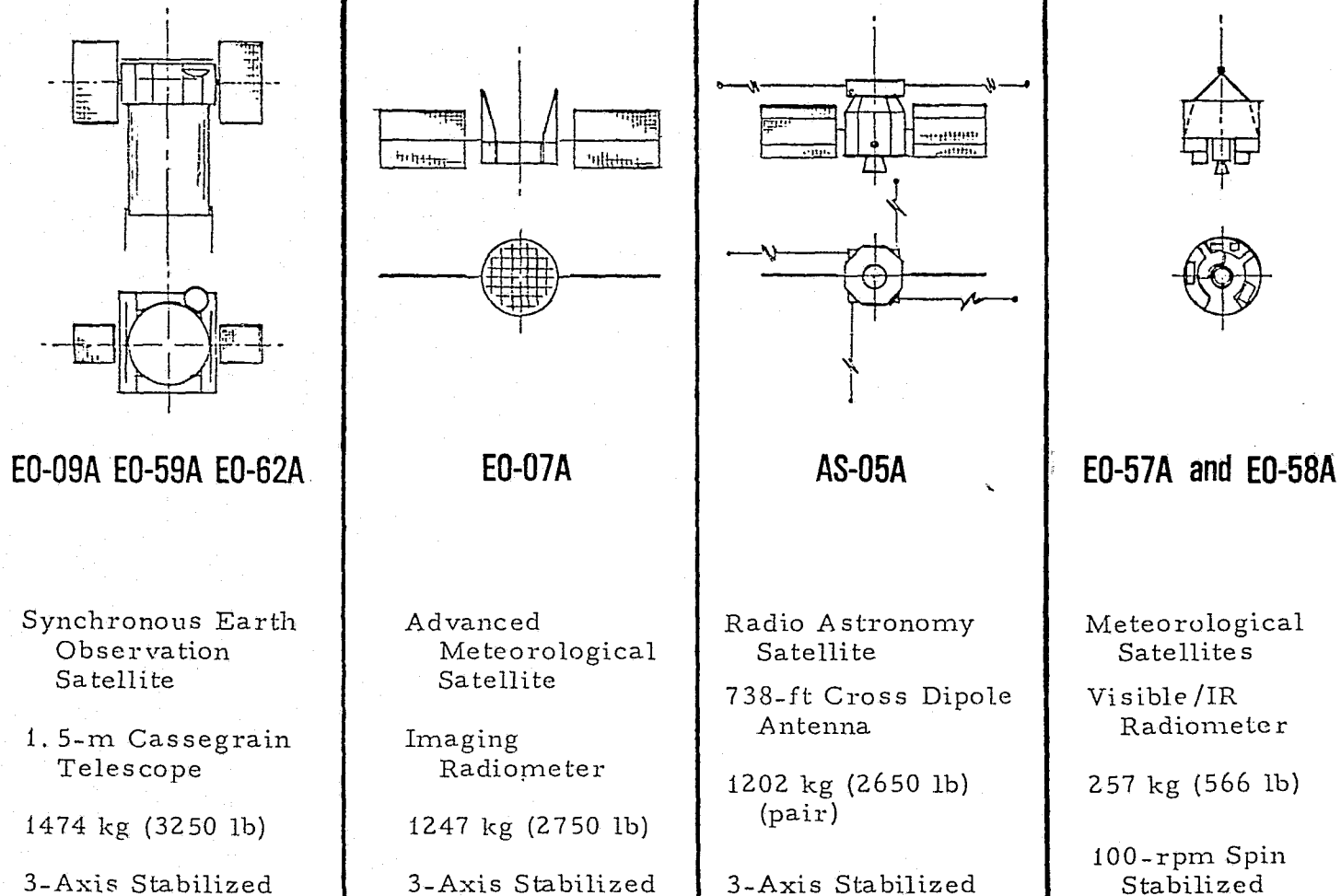

Figure 2-1. Task I NASA Geosynchronous Payloads

The four satellite designs were basically to be analyzed for four transportation system options as shown in Table 2-3. These options were STS-Tug, STS-IUS, STS-SSUS, and ELV. All satellites were expendable with the exception of the baseline Tug EO-09A design, which was retrievable and serviceable, and EO-57A, which was retrievable. Extra options were inserted, one being a modular IUS EO-09A design which was a transition configuration between an expendable IUS design and a serviceable Tug design. The SSUS designs provided for spin stabilization of all the basic three-axis stabilized design satellites during ascent with despin after injection into the final orbit prior to normal mission operations. One EO-09A SSUS design option was studied using a despun platform (or BAPTA-bearing and power transfer assembly) between the spinning SSUS and the non-rotating satellite. This design permitted the satellite to be despun at all times during the mission, but the control problems were complex, the BAPTA was heavy, and the option costly. The EO-57A satellite is intended to spin at 100 rpm on orbit, and the SSUS design option accordingly was a spin/spin concept.

2.1 TUG-DEPLOYED BASELINE SATELLITE DEFINITIONS

2.1.1 General

For each of the four basic geosynchronous satellites studied, a baseline design was defined. The purposes of such designs were to provide bases from which differences resulting from other deployment concepts could be evaluated and to provide realistic configuration and mass property data needed for study tasks beyond Task 1. The SSUS sizing task, for example, requires good estimates of modified satellite weights, which in turn require well-defined baselines.

The satellites studied and several of their primary characteristics are noted in Table 2-4. The EO-59A Geosynchronous ERS and EO-62A Foreign Synchronous EOA have missions identical to those of the EO-09A Synchronous Earth Observatory Satellite, but they are fewer in

Table 2-3. Task I NASA Geosynchronous Spacecraft Design Cases

SPACECRAFT	TUG	IUS	SSUS	ELV
SEOS, GERS, FSEOS EO-09A, EO-59A, EO-62A	3-AXIS RETRIEVAL/ SERVICEABLE	3-AXIS EXPENDABLE	SPIN/DESPIN DESPUN PLATFORM EXPENDABLE	3-AXIS EXPENDABLE
ADVANCED MET SAT EO-07A	3-AXIS EXPENDABLE	3-AXIS EXPENDABLE	SPIN/DESPIN EXPENDABLE	3-AXIS EXPENDABLE
ADVANCED RADIO ASTRONOMY EXPLORER AS-05A	3-AXIS EXPENDABLE	3-AXIS EXPENDABLE	SPIN/DESPIN EXPENDABLE	3-AXIS EXPENDABLE
FSMS/GOMS EO-57A, EO-58A	SPIN RETRIEVAL	SPIN- EXPENDABLE	SPIN-SPIN EXPENDABLE	SPIN- EXPENDABLE

Table 2-4. Payload Satellites Studies

- SYNCHRONOUS EARTH OBSERVATORY: EO-09A, EO-59A, EO-62A
- SYNCHRONOUS METEOROLOGICAL: EO-57A, EO-58A
- ADVANCED SYNCHRONOUS METEOROLOGICAL: EO-07A
- ADVANCED RADIO ASTRONOMY EXPLORER: AS-05A

	<u>EO-09A</u>	<u>EO-57A</u>	<u>EO-07A</u>	<u>AS-05A</u>
• ATTITUDE STABILIZATION ON ORBIT	3-AXIS (EARTH)	SPIN	3-AXIS (EARTH)	3-AXIS (SUN)
• SERVICEABILITY/RETRIEVABILITY	YES ^{**} / YES ^{**}	NO/YES	NO [*] / NO	NO/NO [*]
• DESIGN LIFETIME, YEARS	2	5	5	5
• FIRST LAUNCH DATE	1981	1979	1987	1980

* MARSHALL SPACE FLIGHT CENTER-DIRECTED VARIANCE FROM SHUTTLE SYSTEM PAYLOAD DATA ACTIVITY (SSPDA) LEVEL B DATA SHEETS

** EO-59A AND EO-62A ARE NEITHER SERVICEABLE NOR RETRIEVABLE

number and launched later (starting in 1988). Although it is not planned that they be serviced in orbit or retrieved, it is assumed that they have design characteristics identical to those of the EO-09A satellite. The EO-57A Foreign Synchronous Meteorological Satellite and the EO-58A Geosynchronous Operational Meteorological Satellite are assumed identical, differing only in the lesser number and later launches (starting in 1981) of the EO-57A satellites.

The EO-07A Advanced Synchronous Meteorological Satellite is planned for a single launch and space servicing at 18-month intervals. However, for the purposes of this study, MSFC directed that servicing provisions be neglected.

The AS-05A Advanced Radio Astronomy Explorer satellites, launched in pairs, were planned for at least partial retrieval (two retrieval launches versus four deployment launches). However, for the purposes of this study, MSFC directed that retrieval provisions be neglected, and the later Upper Stage Mission Model showed only one launch in 1987.

In this study, emphasis was placed on one three-axis attitude stabilized satellite (EO-09A) and one spin-stabilized satellite (EO-57A). The EO-07A and AS-05A three-axis stabilized satellites were defined with substantial reliance upon the results of the detailed studies of the EO-09A satellite and without preparation of layout drawings. Less information was available on their design features in the SSPDA data sheets, particularly in the area of mission equipment. For the AS-05A satellite, mission equipment power requirements were not given. The EO-07A mission equipment power requirements were also missing along with the weights of the individual units. These satellites are therefore necessarily discussed in lesser detail. The EO-57A satellite, as defined in the SSPDA Level A and B data sheets, is virtually identical to the Synchronous Meteorological Satellite/Geostationary Operational Environmental Satellite (SMS/GOES) which is currently in use. The description of this satellite is limited herein, because its features are more fully presented in other documents and only changes necessary to accommodate deployment by the Tug need be identified for this study.

2.1.2 Mission Equipment

The mission equipment weight and power summaries for the four basic satellites are presented in Tables 2-5 through 2-8. The data were obtained from the most up-to-date available level A and B data sheets.

For the EO-09A satellite, the 100-Watt average power consumption by the sensors corresponds to simultaneous operation of all sensor assemblies within the telescope housing. The data collection electronics were conservatively assumed to operate continuously from the time of checkout on the Orbiter. The use of automatic sun shields on the end of the telescope results in shutdown of the telescope and its sensors at low angles of the telescope axis relative to the sun line. It is assumed that the shutdown condition is maintained during eclipse periods. Thermal control of mission equipment is assumed to be passive and integral with the equipment.

The EO-57A mission equipment operates continuously, even in eclipse. In addition to the equipment noted in Table 2-6, a UHF transponder is employed in a data collection system which interrogates and relays data from in-situ sensors on earth. The transponder is included as part of the telemetry, tracking, and command subsystem.

The mission equipment of the EO-07A satellite is listed in Table 2-7 along with its total weight. No data on power requirements were available.

For the AS-05A satellite, the mission equipment and its weight are presented in Table 2-8. No data on power requirements were available. The housing and deployment provisions for the large, crossed-dipole antenna array are external to the spacecraft structure and are assumed to include integral passive thermal control provisions. The remainder of the equipment is mounted within the spacecraft.

Table 2-5. Mission Equipment for EO-09A, EO-59A, and EO-62A Satellites

Unit	Weight, kg (lb)	Average Power, Watts
Telescope	594.7 (1311)	30
Sensors	154.5 (341)	100
Data Collection	15.4 (33)	30
Total	764.6 (1685)	160

Table 2-6. Mission Equipment for EO-57A and EO-58A Satellites

Unit	Weight, kg (lb)	Average Power, Watts
Visible Infrared Spin-Scan Radiometer/Sounder	68.10 (150.1)	26.50
VISSR Auxiliary Electronics Module	6.80 (15.0)	0
Magnetometer Sensor Assembly	0.40 (0.9)	0.30
Magnetometer Data Handling Assembly	1.70 (3.7)	3.80
X-Ray Sensor Telescope and Positioner	3.70 (8.2)	0.75
X-Ray Sensor Data Handling Assembly	0.36 (0.8)	1.00
Solar Energetic Particle Counter	1.77 (3.9)	1.75
Solar Energetic Particle Sensor Data Handling Assembly	0.60 (1.3)	0.90
Total	83.40 (183.9)	35.00

Table 2-7. Mission Equipment for the EO-07A Satellite

Unit	Weight, kg (lb)
Visible Imaging Radiometer Infrared Imaging Radiometer Vertical Temperature and Moisture Profilers Magnetometer X-Ray Sensor Energetic Particle Sensor	
Total	307.3 (678)

Table 2-8. Mission Equipment for the AS-05A Satellite

Unit	Weight, kg (lb)
Crossed Dipole Antenna Array	68.0 (150)
Radio Receiver/Spectrum Analyzer	11.3 (25)
Aspect Sensor	6.8 (15)
Baseline Correlator Radio Transreceiver	7.2 (16)
Baseline Phase Differential Correlator	11.3 (25)
Total	104.6 (231)

2.1.3 Servicing/Retrieval

Definition of detailed provisions for satellite servicing on orbit and retrieval after failure or at end of operational life were considered beyond the scope of this study. They entail detailed tradeoffs on modularity concepts, optimum module sizes, and retraction or ejection of deployed satellite equipment.

Of the satellites considered, only the EO-09A-type satellites require consideration of on-orbit servicing. The servicing interval required is one year. It was assumed that servicing consists of replacing equipment modules making up large portions of communications, attitude control, central data processing, electrical power, and thermal control subsystems. Portions of the propulsion and reaction control subsystem might also be included. Mission equipment, attitude control sensors, antennas, reaction control thrusters, solar cell arrays, structure, and insulation are excluded for a variety of reasons including location, interface complexity, and reliability.

Servicing is assumed to be accomplished by a servicing module supported on the forward end of a Space Tug. The Tug would dock with the satellite using a scanning laser radar and a docking probe assembly. The satellite would employ suitably located reflectors to accommodate the controlled approach of the Tug and a docking receptacle to accept and lock onto the docking probe. While attached to the Tug and servicing module, satellite operations would be discontinued. Attitude control and communications would be provided by the Tug. The servicing module would employ a complex handling mechanism to unlock individual equipment panels or platforms on the aft end of the satellite and withdraw them for storage in empty compartments of the servicing module. The mechanism would then attach and lock replacement equipment panels into place on the satellite, checking out the installations electrically after mounting each panel. The servicing module and Tug would remain attached to the satellite until functional checks were made indicating the satellite was operating properly.

If the servicing were unsuccessful for some reason, the retrieval operation would be initiated if the Tug could return both the satellite and servicing module to the Orbiter. If the Tug were unable to return the entire assembly, the return payload capability would determine what had to be jettisoned—the expended equipment panels, satellite propellant, major portions of the servicing module, or the entire satellite.

Normal retrieval of the satellite requires the same docking provisions and functions as required to accommodate servicing on orbit. However, return to the Orbiter requires that various deployed appendages of the satellite be stowed or jettisoned and pressurant and remaining propellants be dumped. Antennas and solar cell paddles are typically deployed by pyrotechnic release devices and spring-loaded hinges. To achieve a capability to restow these assemblies would require substantial design changes and weight increases, with the salvaged hardware probably not warranting the complications. Pyrotechnic severance and jettisoning is considered to be more practical and economical and lowers the weight of the return payload as well. No significant effort was devoted to evaluating retrievability provisions of the EO-09A satellite. Provisions for pyrotechnic severance of antenna booms, solar cell paddles, and electrical cables should involve weight changes small in comparison with present weight uncertainties and contingency allowances.

2.1.4 Satellite Configurations

2.1.4.1 EO-09A Satellite

2.1.4.1.1 Overall

The EO-09A satellite configuration layouts are presented in Figures 2-2, 2-3 and 2-4. The satellite basically consists of a box-like spacecraft structure from which is cantilevered a 2-m (6.56-ft) diameter telescope housing. During operation, the telescope faces the earth but scans up to ± 7.2 deg from nadir. The spacecraft is square in cross section with its corners chamfered to fit within a 4.57-m (15-ft) diameter payload

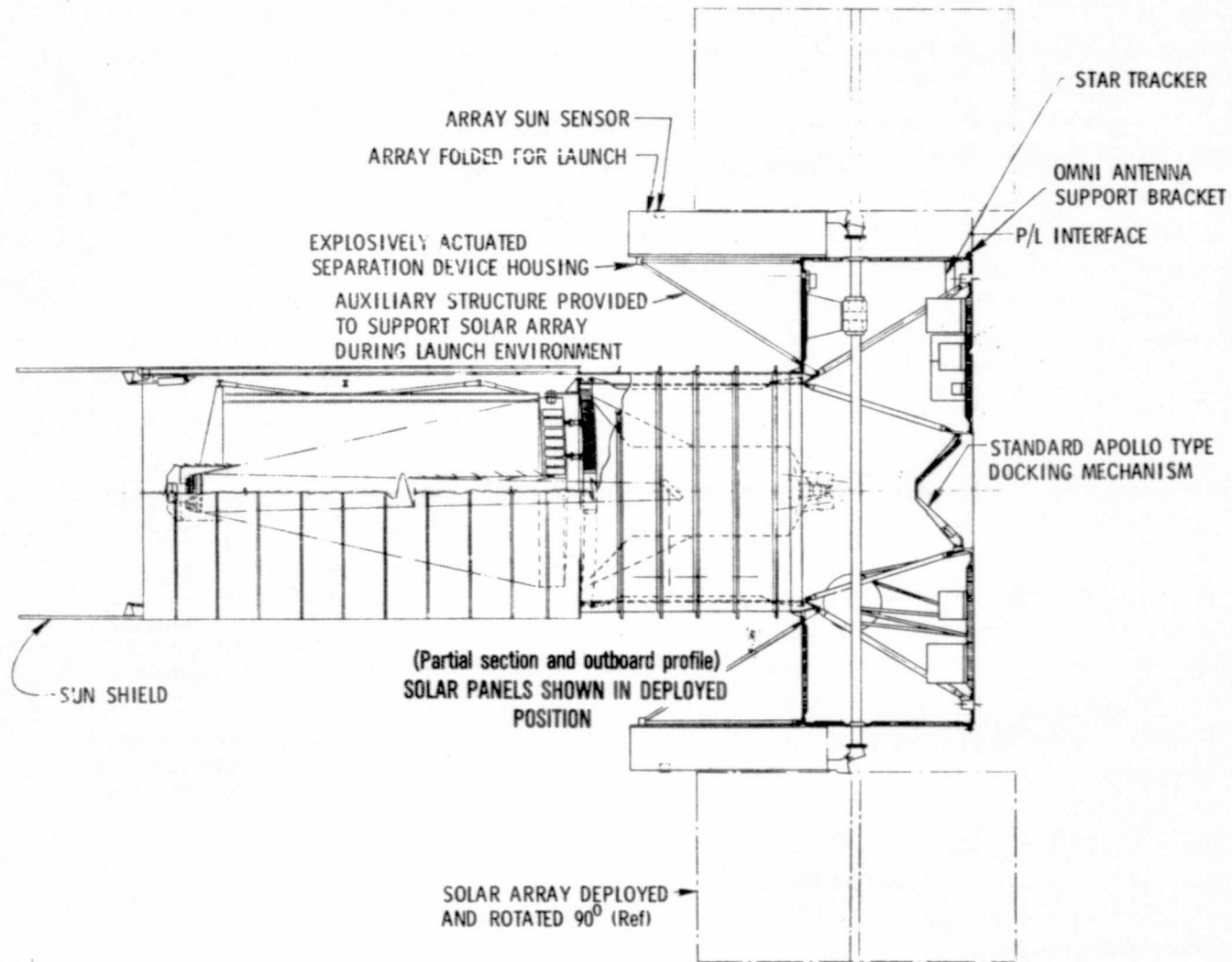

Figure 2-2. E0-09A SEOS Inboard View, Baseline Tug Configuration

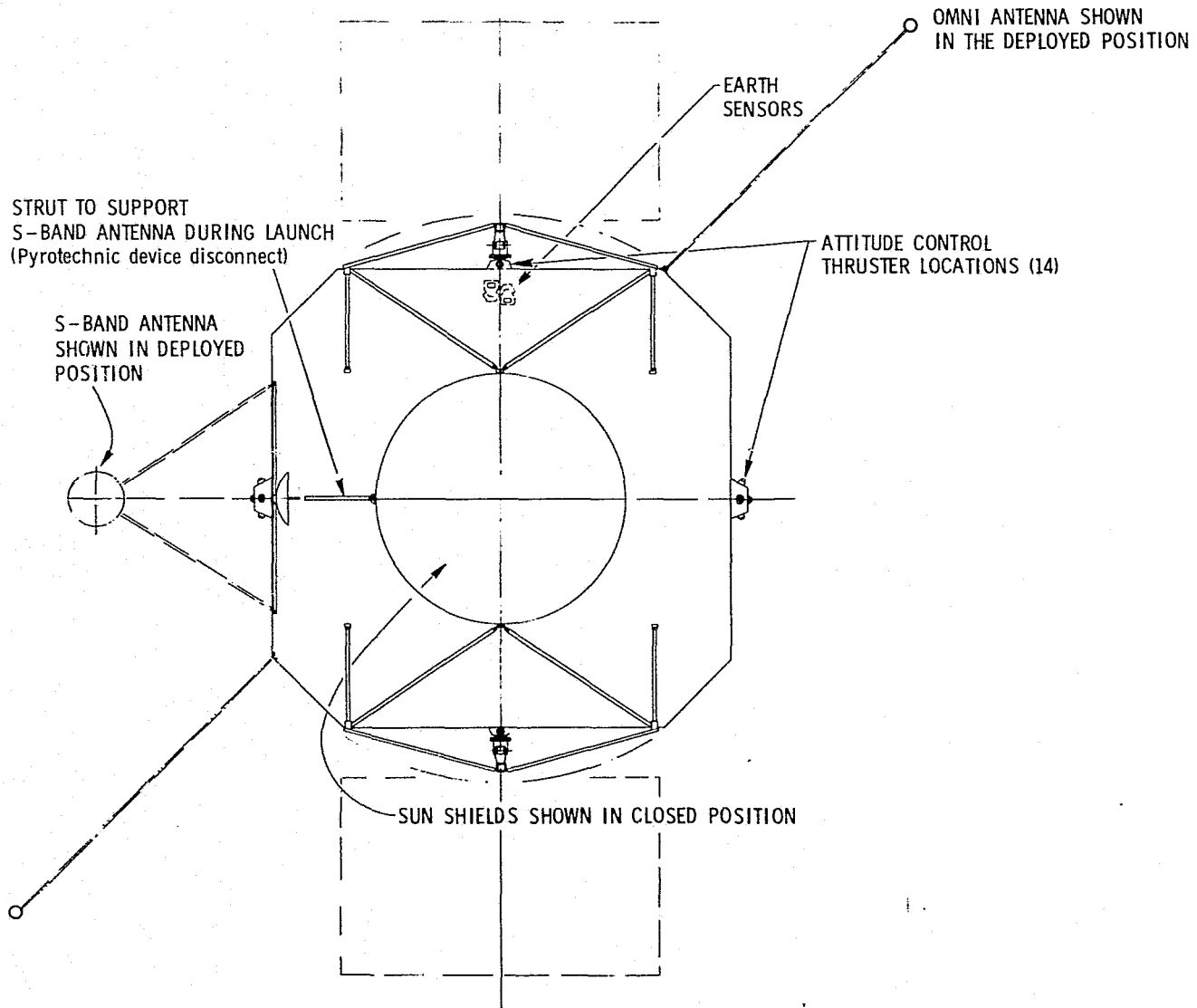

Figure 2-3. E0-9A SEOS End View Telescope Objective, Baseline Tug Configuration

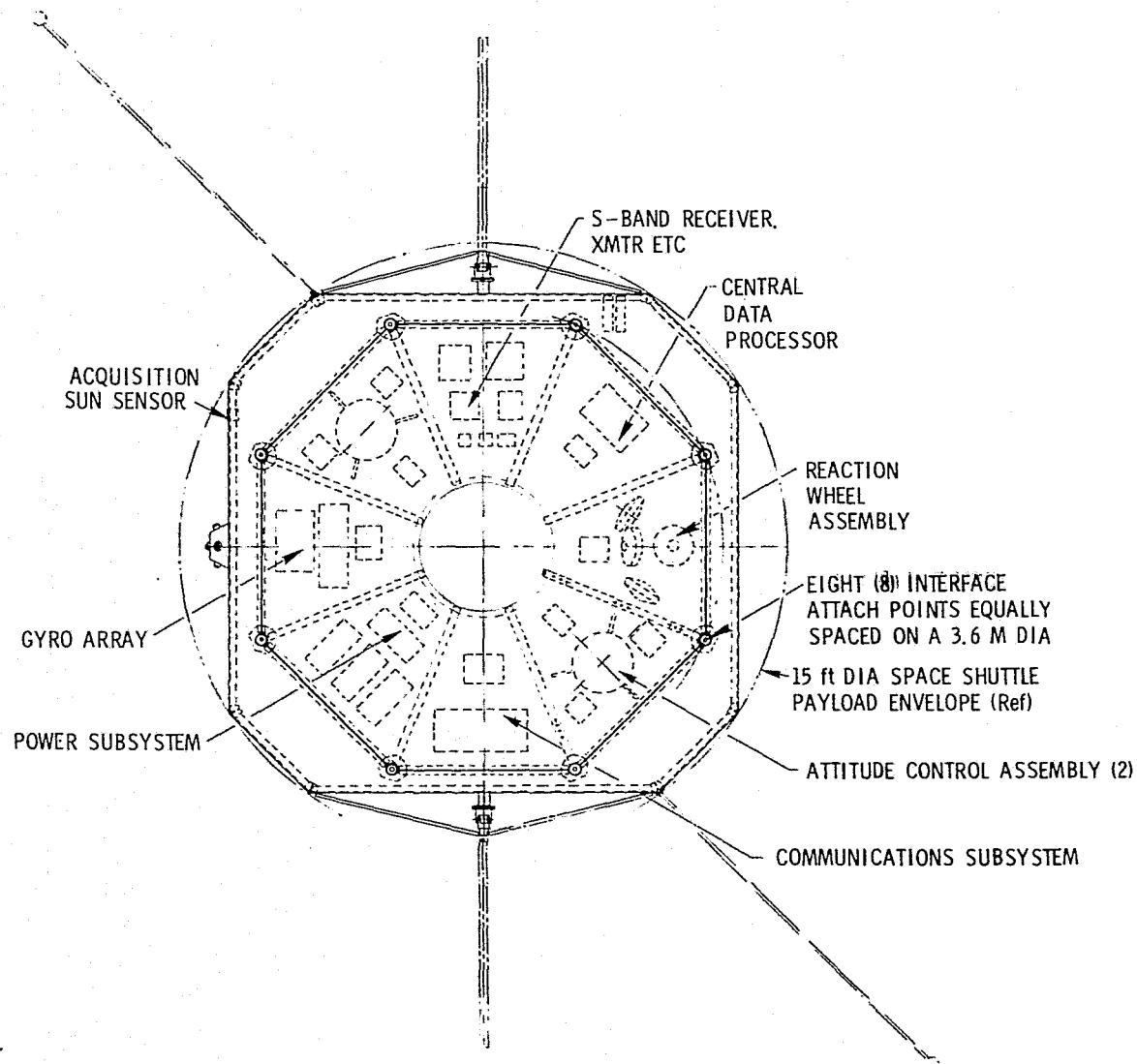

Figure 2-4. EO-09A SEOS End View (Equipment Section)
 Docking Adapter, Baseline Tug Configuration

envelope. On the spacecraft are attached deployable solar cell paddles (and their ascent support structure), a narrow-beam S-Band antenna, and two booms supporting the elements of an omnidirectional S-Band antenna.

2.1.4.1.2 Structure

The spacecraft structure is characterized by its modularity with servicing provisions at the aft end of the satellite surrounding a docking receptacle. Truss members carry launch and maneuver inertia loads from the aft end of the telescope to the structural interface ring which mates with the Tug adapter. Other truss members support the standard Apollo-type docking mechanism (conical receptacle with latching provisions). Radial members position the docking cone and support the removable equipment panels. The latter are used to mount all replaceable equipment and provide thermal control by use of heat pipes within the aluminum honeycomb-sandwich construction. Second surface mirrors are mounted on the exterior surfaces of the equipment panels and on fixed portions of the aft end, if necessary. Other surfaces of the spacecraft employ aluminum honeycomb-sandwich construction to which multilayer insulation is attached externally or internally.

On the forward end of the spacecraft structure, two auxiliary support structures are provided for the solar cell paddles. They mount pyrotechnic release devices which restrain the edges of the solar paddles until the time of paddle deployment upon completion of orbit injection. On the aft end of the spacecraft (on opposite sides), two booms nominally 4.57 m (15 ft) long support lightweight, conical, spiral antenna elements. The booms rotate 180 deg from their stowed positions when deployed on orbit. They rotate out to a maximum distance from the satellite centerline with one element facing forward and one aft to provide nearly complete omnidirectional communication coverage.

2.1.4.1.3 Packaging

The space-servicing requirement is accommodated by modular construction of the satellite wherein serviceable equipments from

individual subsystems are grouped together on one or two removable panels. Each panel has an integral heat pipe suitable for thermal control of the equipment mounted on it. Each panel of power-consuming equipment has firmly supported electrical connectors for obtaining power from the main bus and interfacing with other subsystems. The serviceability provisions add substantially to the structural weight due to the requirements for rigidity, guiding during installation of panels, and the locking mechanisms which can be activated from a single point on each panel. Special provisions are also required for mounting of electrical connectors and possible propellant and pressurant disconnects.

An equipment volumetric packing density of nominally 20 percent within the spacecraft structure is estimated for this space-serviceable satellite. Higher density could be achieved if servicing were not required.

2.1.4.1.4 Interfaces

The mechanical interface of the satellite with the Tug deployment vehicle consists of 8 attachment points on a 3.6-m (11.8-ft) diameter circle to allow attachment of the Tug adapter by means of explosive bolts or nuts. The electrical interface consists of an umbilical connector to accommodate checkout of all subsystems and mission equipment while in the Orbiter and to accept power up to 600 Watts available from the Tug.

2.1.4.2 EO-57A Satellite

The EO-57A satellite configuration is virtually identical to that of the existing spin-stabilized Synchronous Meteorological Satellite (SMS) which is shown in Figure 2-5 and for which a weight statement is given in Table 2-9. In Table 2-10, a list of potential changes for deployment by the Tug is presented along with estimated weight impacts. The only significant changes required in the SMS are the addition of docking provisions to accommodate retrieval from orbit and spin rocket hardware to provide a spin rate of 100 rpm after injection of the satellite into orbit. Additional satellite configurational details may be obtained from reference documents on the SMS.

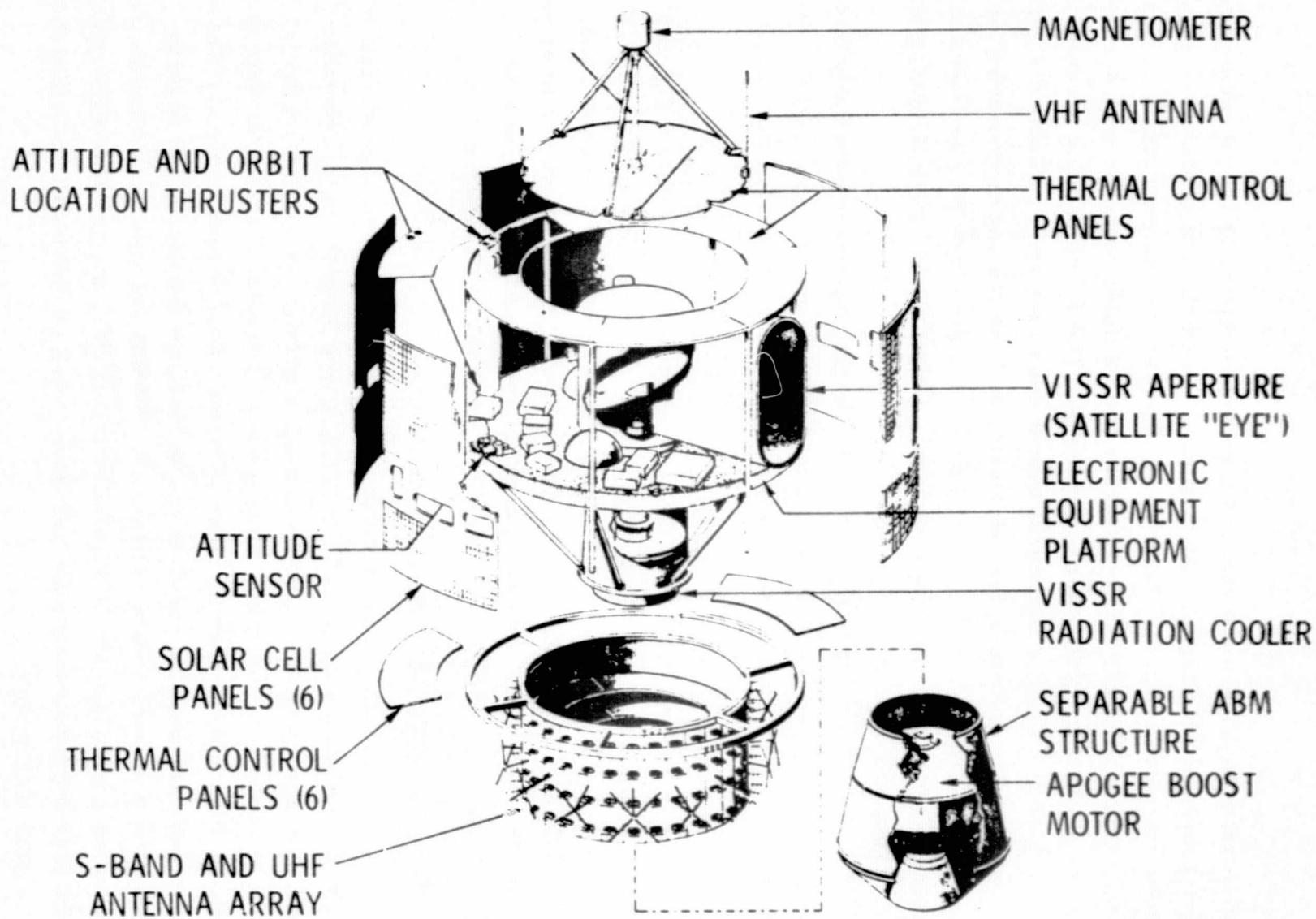

Figure 2-5. SMS/GOES Satellite Configuration

Table 2-9. SMS/GOES Summary Weight Statement

Unit	Weight kg (lb)
Structure	37 (82)
Thermal Control	5 (11)
Stability and Control	13 (28)
Auxiliary Propulsion	10 (21)
Communication	36 (81)
Telemetry and Command	15 (32)
Electrical Power	50 (110)
Mission Equipment	<u>88 (194)*</u>
Satellite Dry Weight	254 (559)
Propellants	<u>37 (81)</u>
Satellite Weight	291 (640)
Adapter	<u>19 (42)</u>
Payload Total Weight	310 (682)
<p>*From Philco-Ford Corp. Report, "Mass Property Data, Synchronous Meteorological Satellite Program, " 15 December 1973.</p>	

Table 2-10. EO-57A Foreign Synchronous Meteorological Satellite

Basically a SMS with the following changes for deployment by Tug:	Weight	
	kg	lb
Structure		
Add docking provisions	+38.1	+84
Annular adapter between VISSR radiation cooler and S-Band and UHF antenna array		
Reflectors for scanning laser radar		
Guidance, Navigation, and Stabilization		
Nutation sensor not required	-0.90	-2
Propulsion and Reaction Control		
Smaller tankage usable	-0.45	-1
Electrical Power		
Add provisions for spin rockets	+2.70	+6
Two ordnance batteries, 1.8 kg (4 lb)		
Ordnance switch and cable, 0.9 kg (2 lb)		
Propellants		
Less hydrazine required	-0.90	-2
Reduced injection velocity uncertainty		
Spin Rockets		
Add two spinup rockets	1.40	+3
Adapter		
Modified for heavier satellite and larger booster interface	5.90	+13
Satellite Weight = 327.6 kg (728 lb)	39.95	+88
Payload Weight Increase	45.85	+101

2.1.4.3 EO-07A Satellite

The EO-07A satellite configuration was not detailed (as previously explained), and the configuration indicated in the Level A and B data sheets is planned for on-orbit servicing. However, the ground rule for this study was an expendable design. Table 2-11 presents a summary of configurational features for the satellite.

2.1.4.4 AS-05A Satellite

The AS-05A satellite configuration also was not detailed as previously explained. The configuration indicated in the Level A and B data sheets is planned for retrieval from orbit, but the ground rule for this study was an expendable design. Figure 2-6 depicts the satellite shown in the data sheets. Table 2-12 presents a summary of configurational features of the satellite.

2.1.5 Electrical Power

The schematic shown in Figure 2-7 is believed representative of the power subsystem for all satellites studied, whether three-axis stabilized with single-degree-of-freedom solar all paddles or spin-stabilized with a body-mounted solar cell array. For paddle-equipped satellites, shunt dissipators of excess power generated early in the mission would be typically mounted on the solar paddles to minimize spacecraft heat dissipation problems.

Tables 2-13 through 2-16 summarize the power subsystem characteristics for the satellites studied. Where mission equipment power was not available, total satellite power was obtained from NASA references* after adding nominally 10 percent for contingency.

* "Spinning Solid Rocket Motor Boost Impact on Geosynchronous Payloads," NASA MSFC, 13 December 1974.

Table 2-11. EO-07A Satellite Configuration Description

- Equipment Enclosure
 - Box or cylindrical structure - without servicing modularity
 - Accommodates subsystem components
 - Accommodates mission equipment
 - Imaging radiometer
 - X-ray sensor, etc.
 - Magnetometer sensor located on auxiliary structure used to support solar cell array
 - Approximately 24% equipment packing density
 - Heat pipes, radiators, and insulation used for thermal control
 - No TUG docking provisions (MSFC direction)
- Solar Cell Array
 - Two independently-driven, rigid paddles
 - Folded for launch (boom hinges)
 - Auxiliary structure provided to support paddles during launch
 - Solar cells facing outward during orbital transfer
- Interfaces
 - Structural - satellite/TUG or IUS - 4 attach points
 - Explosive bolt release
 - Electrical/sensor/signal - plug-type disconnect

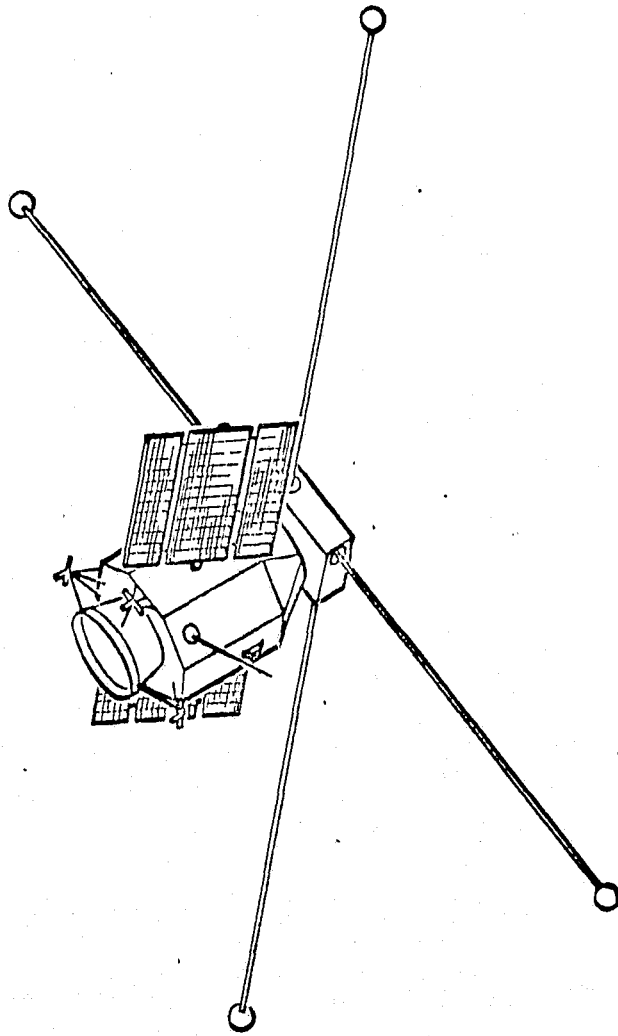

Figure 2-6. AS-05A ARAE Satellite Configuration

Table 2-12. AS-05A Satellite Configuration Description

ANTENNA ARRAY ENCLOSURE

- Box Type Structural Housing for Four Dipole Booms

S/C EQUIPMENT ENCLOSURE

- Non-Modular Octagonal Structure, Adapter and Forward Truncated Pyramid
- Approximately 24% Equipment Packing Density
- Heat Pipes, Radiators and Insulation Used for Thermal Control
- No TUG Docking Provisions (MSFC Direction)

SOLAR CELL ARRAY

- Two Paddles - Each Subdivided into Three Panels
- Folded for Launch to Mate with Octagonal Sides (Boom and Panel Hinges)
- Solar Cells Facing Outward During Launch
- Additional Structural Support Provisions Probably Required
- Two Stage Pyrotechnic Release for Solar Paddle Deployment

INTERFACES

- Structural - Satellite/TUG or IUS
 - Possible Marman Type Clamp with Pyrotechnic Bolt Release
- Electrical Sensor/Signal Plug Type Disconnect

DUAL SATELLITE INSTALLATION

- Possible Lack of Clearance During Launch
- Tip-Off Control May Require the Use of Rails or Canted Installation

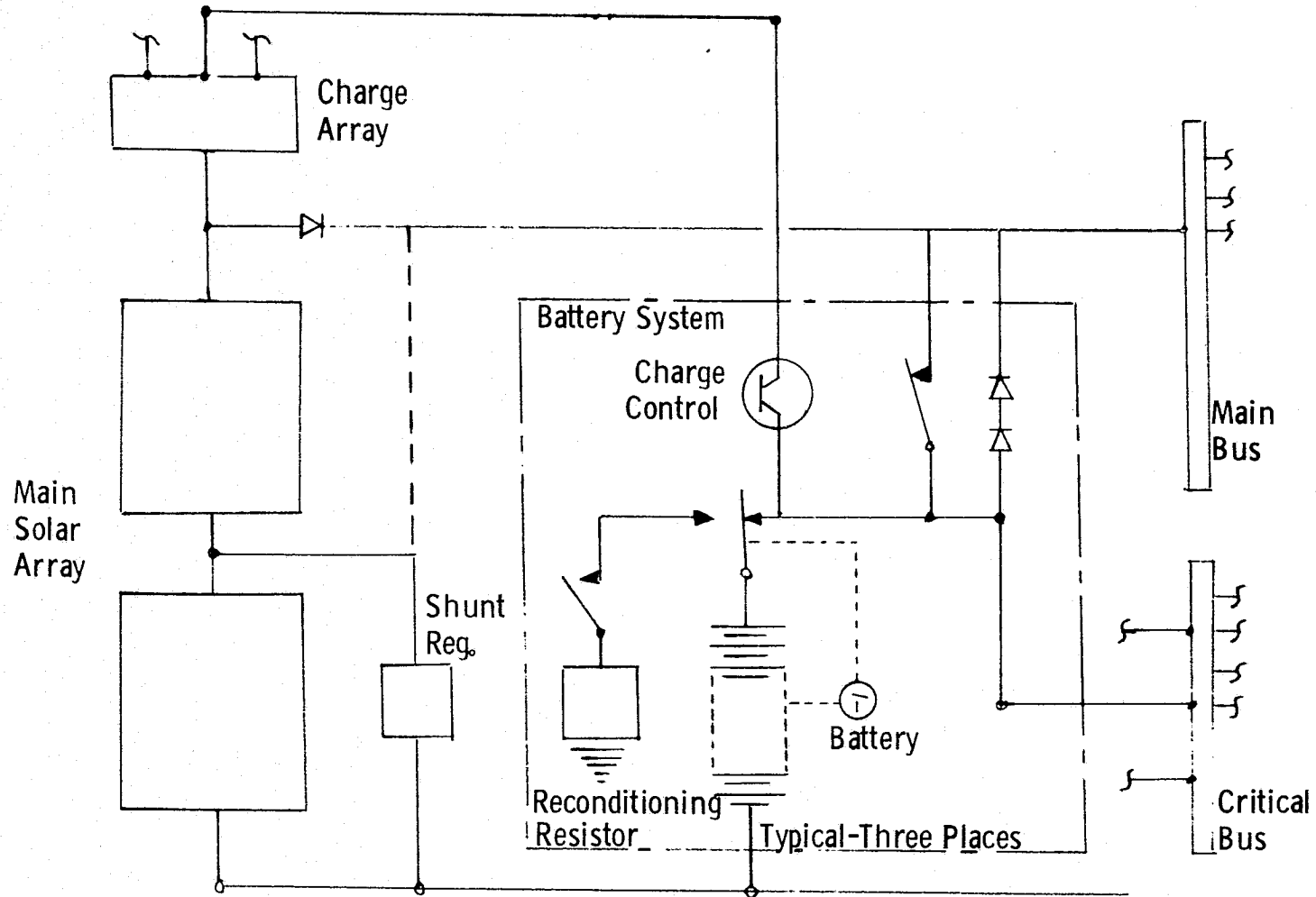

Figure 2-7. Electrical Power Subsystem Typical Schematic

Table 2-13. EO-09A Satellite Electrical Power Subsystem

- TYPE: PADDLE-MOUNTED SOLAR CELL ARRAY WITH SECONDARY BATTERIES,
POWER CONTROLS AND DISTRIBUTION HARNESS
- ARRAY:
- o TWO SINGLE DEGREE OF FREEDOM PADDLES ON COMMON SHAFT
PERPENDICULAR TO EQUATORIAL PLANE
 - o 75 FT² OF HELIOS (VIOLET) SOLAR CELLS: 12.7% EFFICIENCY, 8 MILS THICK
 - o POWER DISSIPATION SHUNTS
 - o BATTERY CHARGE ARRAY SECTIONS
- BATTERIES:
- o 22 Ni Cd CELLS/BATTERY
 - o THREE 8 AH BATTERIES: 60% DOD, 15 WATT HR/LB
 - o CHARGE CONTROLS AND RECONDITIONING

	<u>ELECTRICAL LOAD*, WATTS</u>	<u>ARRAY CAPACITY*, WATTS</u>	
		<u>EOL</u>	<u>BOL</u>
SUNLIGHT	505	505	627.
ECLIPSE	309**	---	---
TRANSFER ORBIT	103	---	111. (Sun Line 30° from Spin Axis)

*LOADS AND CAPACITIES CITED FOR EQUINOX (MAXIMUM BATTERY CHARGING)

**TELESCOPE SHUT DOWN

Table 2-14. EO-57A Satellite Electrical Power Subsystem

- TYPE: BODY-MOUNTED SOLAR CELL ARRAY WITH SECONDARY BATTERIES, POWER CONTROLS AND DISTRIBUTION HARNESS
- ARRAY:
- o CYLINDER WITH AXIS PERPENDICULAR TO EQUATORIAL PLANE
 - o 60 FT² OF HELIOS (VIOLET) SOLAR CELLS: 12.7% EFFICIENCY, 8 MILS THICK
 - o POWER DISSIPATION SHUNTS
 - o BATTERY CHARGE ARRAY SECTIONS
- BATTERIES:
- o 22 Ni Cd CELLS/BATTERY
 - o THREE 4 AH BATTERIES: 60% DOD, 15 WATT HR/LB
 - o CHARGE CONTROLS AND RECONDITIONING

	<u>ELECTRICAL LOAD*, WATTS</u>	<u>ARRAY CAPACITY*, WATTS</u>	
		<u>EOL</u>	<u>BOL</u>
SUNLIGHT	183	183	232
ECLIPSE	158	---	---
TRANSFER ORBIT	60	---	116 (Sun Line 30° from Spin Axis)

*LOADS AND CAPACITIES CITED FOR EQUINOX (MAXIMUM BATTERY CHARGING)

Table 2-15. EO-07A Satellite Electrical Power Subsystem

- TYPE: PADDLE-MOUNTED SOLAR CELL ARRAY WITH SECONDARY BATTERIES,
POWER CONTROLS AND DISTRIBUTION HARNESS
- ARRAY:
- o TWO SINGLE DEGREE OF FREEDOM PADDLES ON DRIVE MECHANISMS WITH AXES PERPENDICULAR TO EQUATORIAL PLANE
 - o 81 FT² OF HELIOS (VIOLET) SOLAR CELLS: 12.7% EFFICIENCY, 8 MILS THICK
 - o POWER DISSIPATION SHUNTS
 - o BATTERY CHARGE ARRAY SECTIONS
- BATTERIES:
- o 22 Ni Cd CELLS/BATTERY
 - o THREE 12 AH BATTERIES: 60% DOD, 15 WATT HR/LB
 - o CHARGE CONTROLS AND RECONDITIONING

	<u>ELECTRICAL LOAD*, WATTS</u>	<u>ARRAY CAPACITY*, WATTS</u>	
		<u>EOL</u>	<u>BOL</u>
SUNLIGHT	580	580	740
ECLIPSE	505	---	---
TRANSFER ORBIT	37(AVG)	---	132 (Sun Line 30 ^o from Spin Axis)

*LOADS AND CAPACITIES CITED FOR EQUINOX (MAXIMUM BATTERY CHARGING)

Table 2-16. AS-05A Satellite Electrical Power Subsystem

- TYPE: PADDLE-MOUNTED SOLAR CELL ARRAY WITH SECONDARY BATTERIES, POWER CONTROLS AND DISTRIBUTION HARNESS
- ARRAY:
- o TWO SINGLE DEGREE OF FREEDOM PADDLES ON COMMON SHAFT PERPENDICULAR TO ECLIPTIC PLANE
 - o 59 FT² OF HELIOS (VIOLET) SOLAR CELLS: 12.7% EFFICIENCY, 8 MILS THICK
 - o POWER DISSIPATION SHUNTS
 - o BATTERY CHARGE ARRAY SECTIONS
- BATTERIES:
- o 22 Ni Cd CELLS/BATTERY
 - o THREE 8 AH BATTERIES: 60% DOD, 15 WATT HR/LB
 - o CHARGE CONTROLS AND RECONDITIONING

	<u>ELECTRICAL LOAD*, WATTS</u>	<u>ARRAY CAPACITY*, WATTS</u>	
		<u>EOL</u>	<u>BOL</u>
SUNLIGHT	387	387	493
ECLIPSE	337	---	---
TRANSFER ORBIT	37 (AVG)	---	88 (Sun Line 30° from Spin Axis)

*LOADS AND CAPACITIES CITED FOR EQUINOX (MAXIMUM BATTERY CHARGING)

2.1.6 Propulsion and Reaction Control

An auxiliary propulsion subsystem employing storable mono-propellant hydrazine fuel is assumed for use on all satellites. The general requirements and means of implementation are noted in Table 2-17. For the Tug-deployed satellites, the propellant quantity provided is adequate to correct the initial orbit injection position and velocity errors and to satisfy all on-orbit requirements over the lifetime of the satellite.

When all propellants required for injection error correction, orbit maintenance, and attitude control are converted to an equivalent velocity increment (ΔV) capability, using a specific impulse of 220 sec, the following ΔV 's result:

<u>Satellite</u>	<u>ΔV, ft/sec</u>
EO-09A	500
EO-57A	665
EO-07A	700
AS-05A	182

2.1.7 Thermal Control

The basic features of passive thermal control subsystems for the EO-09A, EO-07A, and AS-05A Satellites are presented in Tables 2-18, 2-19, and 2-20, respectively.

2.1.8 Mass Properties

Tables 2-21, 2-22, and 2-23 list all the major equipment items required for each subsystem of the satellites studied and estimate their weights and average powers.

Table 2-24 presents other preliminary mass properties for the satellites. The center of gravity location and moments of inertia about the principal axes are provided for the conditions where the solar all paddles are stowed and where they are deployed.

Table 2-17. Propulsion and Reaction Control Subsystem

- Hydrazine supply with catalytic decomposition thrusters
- Requirements
 - Translation maneuvers (injection error correction and orbit maintenance)
 - Attitude control torques (scanning, precession, momentum wheel unloading)
 - Minimum plume impingement on sensors and solar arrays
- Implementation: 3-Axis
 - 2-4 pressure-regulated, spherical N_2H_4 tanks
 - 14 thrusters, 2.248 - 22.48-n (0.5 - 5-lb) thrust
- Implementation: Spin-stabilized
 - 3 blowdown, spherical N_2H_4 tanks
 - 4 thrusters, 22.48-n (5-lb) thrust plus
2 thrusters, 2.248-n (0.5-lb) thrust
 - 2 spinup rockets

2.2

BASIC DESIGN COMPATIBILITY WITH
SPIN-STABILIZED OPERATIONS

The following seven satellites of four basic designs were reviewed for basic design capability with on-orbit, spin-stabilized operations:

- a. EO-09A, EO-59A, EO-62A
- b. AS-05A
- c. EO-07A
- d. EO-57A, EO-58A.

The first three types appear incompatible as listed in Table 2-25. Figure 2-8 indicates the earth-pointing feature of the 1.5 m

Table 2-18. EO-09A Satellite Thermal Control Subsystem

- Spacecraft thermal control concept: Passive
 - Power dissipation - 350 Watts, exclusive of telescope and solar paddle shunts
 - Attitude control - 3-axis stabilization; earth-pointing longitudinal axis
 - Implementation
 - Variable conductance heat pipes
 - Optical surface-reflector radiators
 - Multilayer insulation
- | | |
|---|-----------------|
| } | 11.3 kg (25 lb) |
| } | 20.4 kg (45 lb) |
- Compatible with Tug, IUS, and SSUS
 - Prefer open structure for SSUS adapter
 - Orient heat pipes circumferentially for SSUS transfer

cassegain telescope main mission equipment which drives the satellite design of EO-09A, EO-59A, and EO-62A to a three-axis-stabilized on-orbit operation to achieve the required orientation and pointing accuracy. Figure 2-8 also shows the general orientation of the AS-05A satellite. This satellite operates as one of a pair in orbit and features a cross dipole antenna extending 450 m (1475 ft) from tip to tip. The antenna stability desired and pointing requirements appear to preclude designs other than three-axis stabilization on orbit.

The EO-07A satellite did not have much detailed data on mission equipment but appeared to be of the type which would preclude spin-scan operation such as in EO-57A and EO-58A. This satellite might possibly be adaptable to a dual spin satellite stabilized by the rotating solar drum with the mission sensor equipment on a despun platform. The satellite is depicted in Figure 2-9 along with EO-57A and EO-58A.

Table 2-19. EO-07A Satellite Thermal Control Subsystem

- Spacecraft thermal control concept: Passive
 - Power dissipation - 580 Watts, exclusive of solar paddle shunts
 - Attitude control - 3-axis stabilization, earth-pointing longitudinal axis
 - Implementation
 - Variable conductance heat pipes
 - Optional surface-reflector radiators
 - Multilayer insulation
- | | |
|---|-----------------|
| } | 19.5 kg (43 lb) |
| } | 14.5 kg (32 lb) |
- Alternative approach is active system employing louvered radiators
 - Compatible with Tug, IUS, and SSUS
 - Prefer open structure SSUS adapter
 - Orient heat pipes circumferentially for SSUS transfer

The EO-57A and EO-58A satellites are compatible with on-orbit spin-stabilized operation and are so designed. These satellites are evolutions of the present SMS/GOES flown on the Delta 2914 with a spin-stabilized third stage. The same basic 100-rpm spin-scan radiometer is the principal mission equipment, and accordingly the satellite design specified 100-rpm spin-stabilized operation.

The variety of satellites flown with present expendable launch vehicles (ELV) indicates that in many cases the satellite designer can adapt his design and the mission equipment operations to the features of the ELV. Numerous satellites flown on the Delta and Atlas Centaur launch vehicles feature spin-stabilized injection using apogee kick motors (AKM) and either spin-stabilized orbital operation or despin to an on-orbit three-axis-stabilized operation. Similarly, the availability of three-axis-stabilized

Table 2-20. AS-05A Satellite Thermal Control Subsystem

- Spacecraft thermal control concept: Passive
 - Power dissipation - 387 Watts, exclusive of solar paddle shunts
 - Attitude control - 3-axis stabilization; one side faces sun
 - Implementation
 - Isothermalizer heat pipes } 5.9 kg (13 lb)
 - Painted radiators } 5.9 kg (13 lb)
 - Multilayer insulation 12.2 kg (27 lb)
- Compatible with Tug, IUS, and SSUS
 - Slow roll required during transfer on Tug and IUS

injection capability in the Centaur, Agena, and Titan III Transtage upper stages has permitted satellites to be entirely three-axis stabilized. The transportation system operations and their characteristics are among the first design trade considerations in a new satellite concept. Once a concept has been formulated and the design and development begin, it usually becomes a prohibitive task to reorient the design to a different stabilization technique.

2.3 ELV OPTIONS FOR GEOSYNCHRONOUS SATELLITES

The seven satellites of four basic designs were reviewed for compatibility with launch by expendable launch vehicles (ELV). The ELVs considered were those which are comprised in the National Launch Vehicle Summary, August 1972. Feasible ELV options exist for all the satellites studied as summarized in Table 2-26 and illustrated in Figures 2-10 through 2-16.

ORIGINAL PAGE 1:
OF POOR QUALITY

Table 2-21. Equipment Summary for Tug-Deployed EO-09A Satellite

Item	Weight		Average Power, Watts
	kg	lb	
Structure	(350.3)	(772)	(0)
Basic structure	181.0	399	
Aft closures for space-replaceable units	97.1	214	
Space-replaceable unit mechanisms	36.3	80	
Ducking provisions (adapter, reflectors)	24.5	54	
Solar array boom	9.1	20	
Antenna booms	2.3	5	
Thermal Control	(31.7)	(70)	(0)
Heat pipe and radiator assemblies	11.3	25	
Insulation and paint	20.4	45	
Guidance, Navigation, and Stabilization	(98.5)	(217)	(86)
Earth sensors(2)	11.8	26	10
Sun sensor (acquisition)	0.5	1	0.5 (acq. only)
Star sensors (2)	9.1	20	8
Gyro arrays (6)	14.5	32	30
Momentum wheel arrays (6)	46.3	102	20
Acquisition electronics	0.9	2	1.5 (acq. only)
Valve drive amplifiers (2)	2.7	6	3
Interface electronics (2)	12.7	28	15
Propulsion and Reaction Control	(26.3)	(58)	(0)
Tankage, pressurization, and plumbing	15.4	34	0
Thrusters and valves (22-48-w/5-lb thrusters) (14)	10.9	24	≈0
Telemetry, Tracking, and Command	(24.9)	(55)	(115)
S-Band transmitters (20-Watt) (2)	2.7	6	100
S-Band transmitters (1-Watt) (2)	1.8	4	5
S-Band receivers (2)	1.8	4	6 (5 operating, 1 standby)
Baseband assemblies (2)	0.9	2	4
Diplexer and hybrid	1.8	4	0
Antenna (parabolic)	0.9	2	0
Antenna (2 conical elements)	0.9	2	0
Programmer, RF switches, cabling	14.1	31	≈0
Central Data Processor	(17.2)	(38)	(45)
Computer	9.1	20	
Data acquisition and control	6.3	14	
Miscellaneous	1.8	4	
Electrical Power	(207.8)	(458)	(59)
Solar array and drive	38.6	85	≈0
Batteries (3)	33.6	74	50 (when charging)
Distribution and regulation	123.8	273	} ≈9
Power control unit	11.8	26	
Contingency (15%)	(113.4)	(250)	(41)
Mission Equipment	(764.4)	(1635)	(160)
Telescope	594.7	1311	30
Sensors	154.7	341	100
Data collection	15.0	33	30
Satellite Dry Weight	1634.5	3603	
Propellants	(125.6)	(277)	
Expendable	119.7	264	
Non-Expendable	5.9	13	
Satellite Weight	1760.1	3880	
Adapter	(88.4)	(195)	
Payload Weight	1848.5	4075	

ORIGINAL PAGE
OF POOR QUALITY

Table 2-22. Equipment Summary for Tug- or IUS-Deployed EO-07A Satellite

Item	Weight		Average Power, Watts
	kg	lb	
Structure	(87.1)	(192)	
Basic structure	66.6	147	
Mechanical integration	9.1	20	
Solar array booms	9.1	20	
Antenna booms	2.3	5	
Thermal Control	(34.0)	(75)	
Heat pipe and radiator assemblies	19.5	43	
Insulation and paint	14.5	32	
Guidance, Navigation, and Stabilization	(104.4)	(230)	
Earth sensors (2)	11.8	26	
Sun sensor (acquisition)	0.5	1	
Star sensors (2)	9.1	20	
Gyro arrays (6)	14.5	32	
Momentum wheel arrays (6)	46.3	102	
Attitude control electronics (2)	22.2	49	
Propulsion and Reaction Control	(18.6)	(41)	
Tankage, pressurization, and plumbing	11.8	26	
Thrusters and valves (4, 5-w/1-lb thrusters) (14)	6.8	15	
Telemetry, Tracking, and Command	(61.1)	(135)	
S-Band transmitters (2-Watt) (2)	1.8	4	
S-Band transmitters (1-Watt) (2)	1.8	4	
S-Band receivers (2)	1.8	4	
Baseband assemblies (2)	0.9	2	
Data processor	34.0	75	
Digital telemetry units (2)	4.5	10	
Decoder and distribution units (2)	3.6	8	
Diplexer and hybrid	1.8	4	
Antenna (parabolic)	0.9	2	
Antenna (2 conical elements)	0.9	2	
Programmer, RF switches, cabling	9.1	20	
Electrical Power	(134.7)	(297)	
Solar array	36.7	81	
Array drive	6.8	15	
Batteries (3)	49.9	110	
Power control unit	13.6	30	
Array shunt	3.6	8	
Reconditioning resistor	0.5	1	
Electrical integration	23.6	52	
Contingency (15%)	(65.8)	(145)	
Mission Equipment	(307.5)	(678)	
Imaging radiometrics			
Vertical temperature/moisture profile scanners			
Space environment monitoring system			
Satellite Dry Weight	813.2	1793	
Propellants	(89.4)	(197)	
Expendable	85.3	188	
Non-Expendable	4.1	9	
Satellite Weight	902.6	1990	
Adapter	45.4	100	
Payload Weight	948.0	2090	

Table 2-23. Equipment Summary for Tug- or IUS-Deployed AS-05A Satellite

Item	Weight		Average Power, Watts
	kg	lb	
Structure	(77.2)	(170)	
Basic structure	56.7	125	
Mechanical integration	9.1	20	
Solar array booms	9.1	20	
Antenna booms	2.3	5	
Thermal Control	(18.1)	(40)	
Heat pipe and radiator assemblies	5.9	13	
Insulation and paint	12.2	27	
Guidance, Navigation, and Stabilization	(66.7)	(147)	
Fine sun sensors (2)	5.9	13	
Star sensors (2)	9.1	20	
Gyro arrays (6)	14.5	32	
Momentum wheel arrays (6)	14.5	32	
Sun sensor (acquisition)	0.5	1	
Attitude control electronics (2)	22.2	49	
Propulsion and Reaction Control	(12.7)	(28)	
Tankage, pressurization, and plumbing	6.8	15	
Thrusters and valves (2.248-w/0.5-lb thrusters) (14)	5.9	13	
Telemetry, Tracking, and Command	(23.0)	(51)	
S-Band transmitters (10-Watt) (2)	2.7	6	
S-Band transmitters (1-Watt) (2)	1.8	4	
S-Band receivers (2)	1.8	4	
Baseband assemblies (2)	0.9	2	
Digital telemetry units (2)	4.5	10	
Decoder and distribution units (2)	3.6	8	
Diplexer and hybrid	1.8	4	
Antenna (2 conical elements)	0.9	2	
Antenna (2 conical elements)	0.9	2	
Cabling	4.1	9	
Electrical Power	(90.4)	(199)	
Solar array	24.5	54	
Array drive	4.5	10	
Batteries (3)	33.6	74	
Power control unit	9.1	20	
Array shunt	2.3	5	
Reconditioning resistor	0.5	1	
Harness	15.9	35	
Contingency (15%)	(43.1)	(95)	
Mission Equipment	(104.7)	(231)	
Crossed dipole antenna array	68.0	150	
Radio receiver/spectrum analyzer	11.3	25	
Aspect sensor	6.8	15	
Baseline correlator radio transreceiver	7.3	16	
Baseline phase diffuser correlator	11.3	25	
Satellite Dry Weight	435.9	961	
Propellants	(12.7)	(28)	
Expendable	11.8	26	
Non-Expendable	0.9	2	
Satellite Weight	448.6	989	
Adapter	22.7	50	
Payload Weight	471.3	1039	

Table 2-24. Tug-Launched Satellite Inertial Data

Item	EO-09A	EO-07A	AS-05A	EO-57A*
Weight, kg (lb)	1760.0 (3880.0)	903.0 (1990.0)	449.0 (989.0)	330.0 (728.0)
Arrays Folded During Ascent				
C.G. from aft end, cm (in.)	146.1 (57.5)	17.8 (7.0)	121.9 (48.0)	144.0 (56.7)
Moments of inertia, kg m ² (slug ft ²)				
Roll _{ix}	2393.0 (1765.0)	1071.0 (790.0)	207.0 (153.0)	104.0 (77.0)
Pitch _{iy}	5095.0 (3758.0)	583.0 (430.0)	309.0 (228.0)	103.0 (76.0)
Yaw _{iz}	5284.0 (3897.0)	651.0 (480.0)	330.0 (243.0)	113.0 (83.0)
Arrays Deployed (on Orbit)				
C.G. from aft end, cm (in.)	143.3 (56.4)	13.0 (5.1)	121.9 (48.0)	144.0 (56.7)
Moments of inertia, kg m ² (slug ft ²)				
Roll _{ix}	2548.0 (1879.0)	1308.0 (965.0)	244.0 (180.0)	104.0 (77.0)
Pitch _{iy}	5106.0 (3766.0)	508.0 (375.0)	306.0 (226.0)	103.0 (76.0)
Yaw _{iz}	5449.0 (4019.0)	813.0 (600.0)	369.0 (272.0)	113.0 (83.0)

*Has body-mounted solar arrays.

Table 2-25. Compatibility of Designated Satellites with Spin Operation on Orbit
Incompatible

- o EO-09A - 1.5 meter telescope is earth pointing
- EO-59A - Represents principal spacecraft structure and major mass
- EO-62A - Earth pointing 90 degree to required spin axis orientation normal to equatorial plane
- A dual spin satellite design with the telescope on the despun platform and a large rotor, side mounted, spinning normal to the telescope axis would offer severe packaging problems in Orbiter Bay
- Presence of spinning rotor might introduce jitter in telescope sensor

- o AS-05A - 1475 feet long crossed dipole antenna assembly pointing capability would be compromised by spinning
- Dual spin satellite with antennas on despun platform would appear to preclude pointing antennas in all potentially desired directions due to rotor spin normal to orbit plane and required precession propellant to reorient

- o EO-07A - Mission sensors appear incompatible with spin scan operation
- Dual spin with sensors on despun platform may be feasible

Compatible

- o EO-57A - Designed to be spun at 100 rpm, basic spin scan sensor
- EO-58A - Predecessor SMS/GCES satellite now operational (Delta 2914 launched)

EO-09A SEOS
EO-59A GERS
EO-62A FSEOS

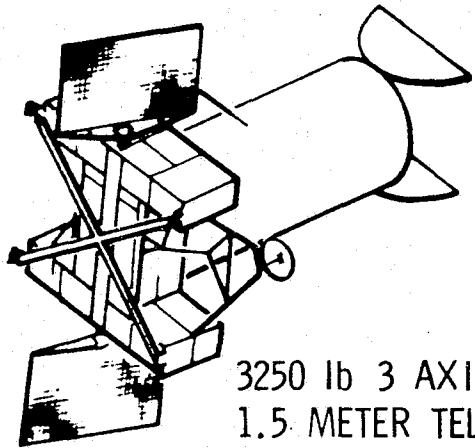

3250 lb 3 AXIS
1.5 METER TELESCOPE



AS-05A ARAE

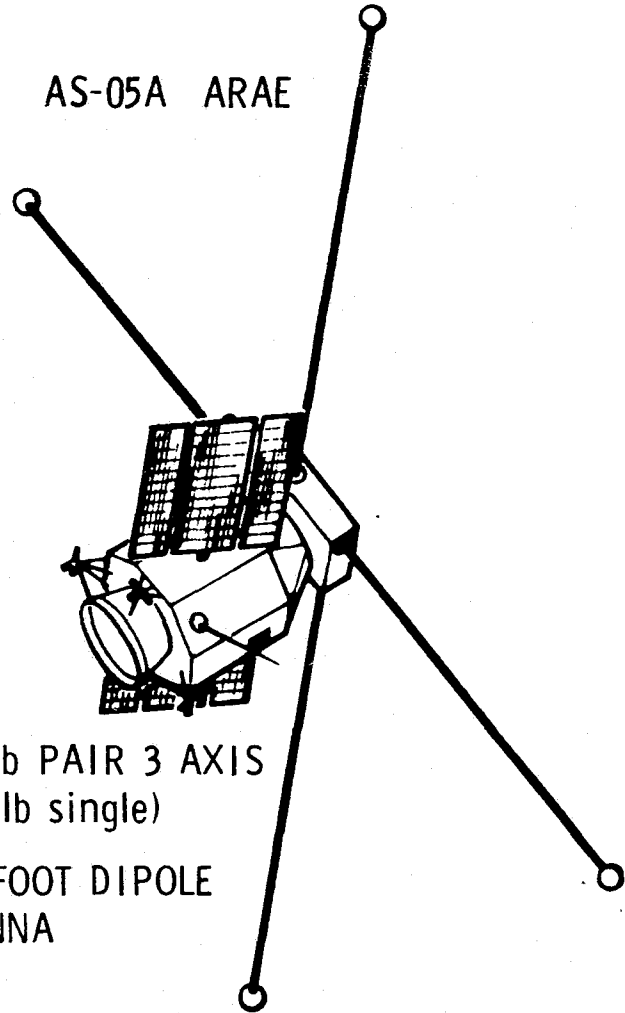

2650 lb PAIR 3 AXIS
(1325 lb single)
1450 FOOT DIPOLE
ANTENNA

Figure 2-8. EO-9A/AS-05A Synchronous Equatorial Satellites

EO-57A FSMS
EO-58A GOMS

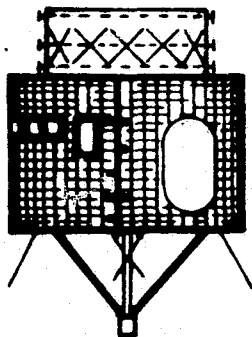

566 lb 100 rpm SPIN
SPIN SCAN RADIOMETER



EO-07A ASMS

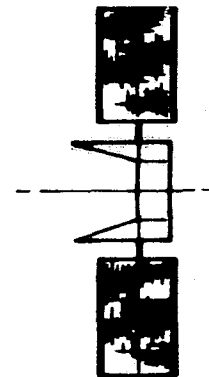

2750 lb 3 AXIS
IMAGING RADIOMETRICS

Figure 2-9. EO-57A/EO-07A Synchronous Equatorial Satellites

Table 2-26. ELV Options Summary

o	EO-09A EO-59A EO-62A	3250 lbs 3-Axis	TIIIE/Centaur D-IT Viking Fairing-Repackaged S/C to 12.5 ft dia. TIIIE/Centaur D-IT 16.7ft O. D. Fairing-S/C as is
o	EO-07A	2743 lbs 3-Axis	TIIIE/Centaur D-IT Viking Fairing-S/C as is TIIIC 10 ft Diameter Fairing-S/C repackaged to 9 ft Dia TIIIC Viking Fairing-S/C as is
o	AS-05A	2644 lbs Dual 1322 lbs Single 3-Axis	TIIIE/Centaur D-IT Viking Fairing-S/C as is Side by Side TIIIC 10 ft Diameter Fairing-S/C mounted in Tandem TIIIC Viking Fairing-S/C as is Side by Side
o	EO-57A EO-58A	566 lbs 100 rpm Spin	Delta 2914-S/C as is (SMS/GOES)

Feasible Options Exist for all Task I Geosynchronous Payloads
 ELV 3-Axis Designs Similar to IUS Designs
 ELV Spin Designs Similar to IUS and SSUS Designs

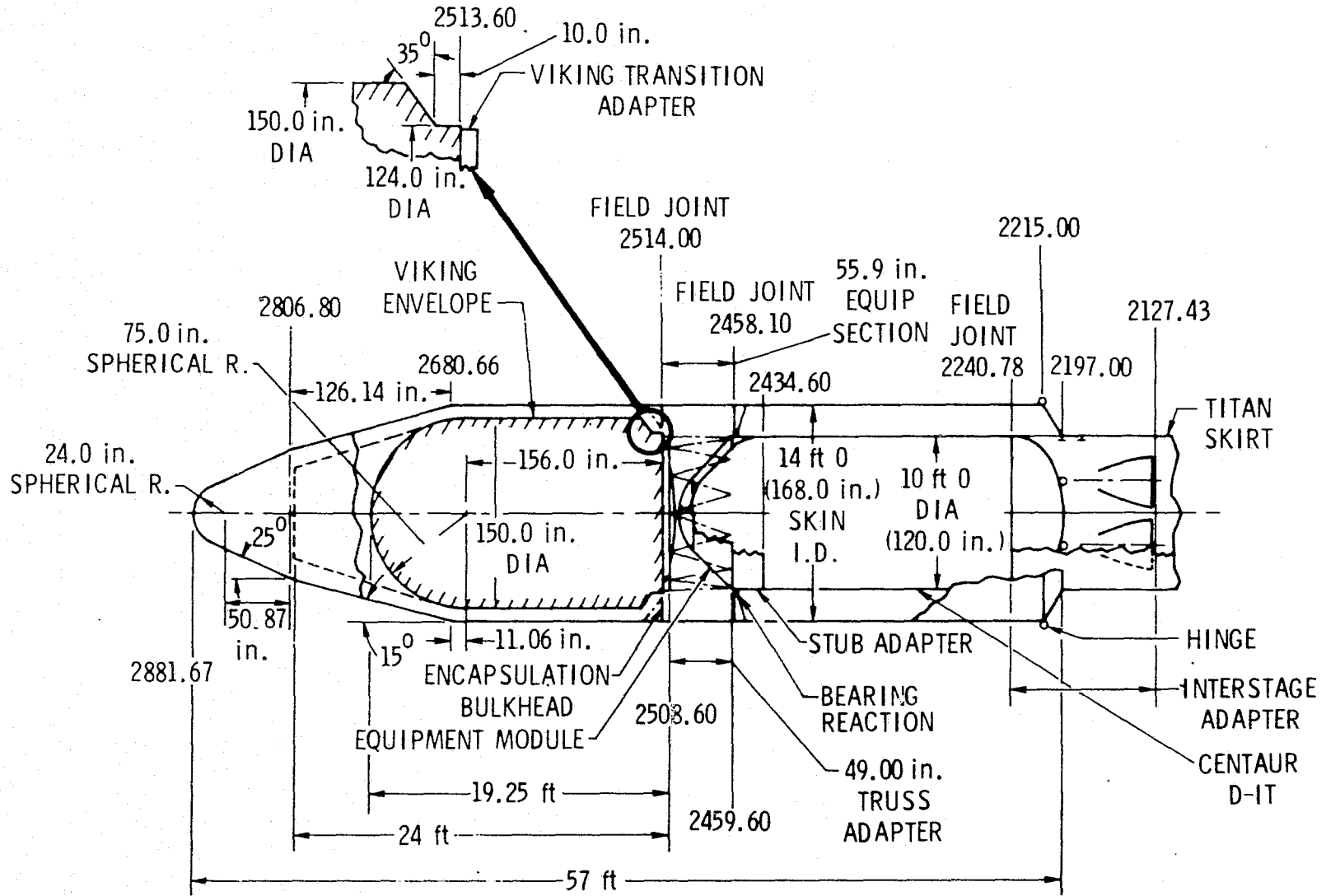

Figure 2-10. Titan IIIE/Centaur D-1T Standard Centaur Fairing Envelope

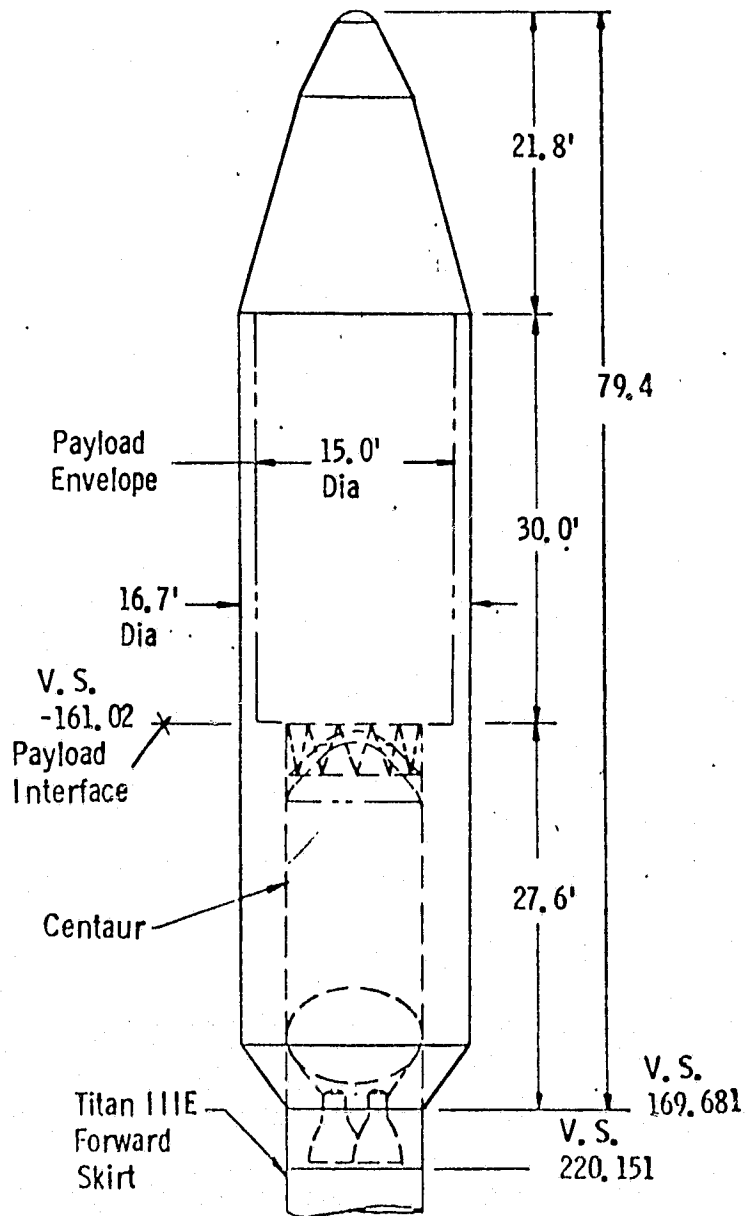
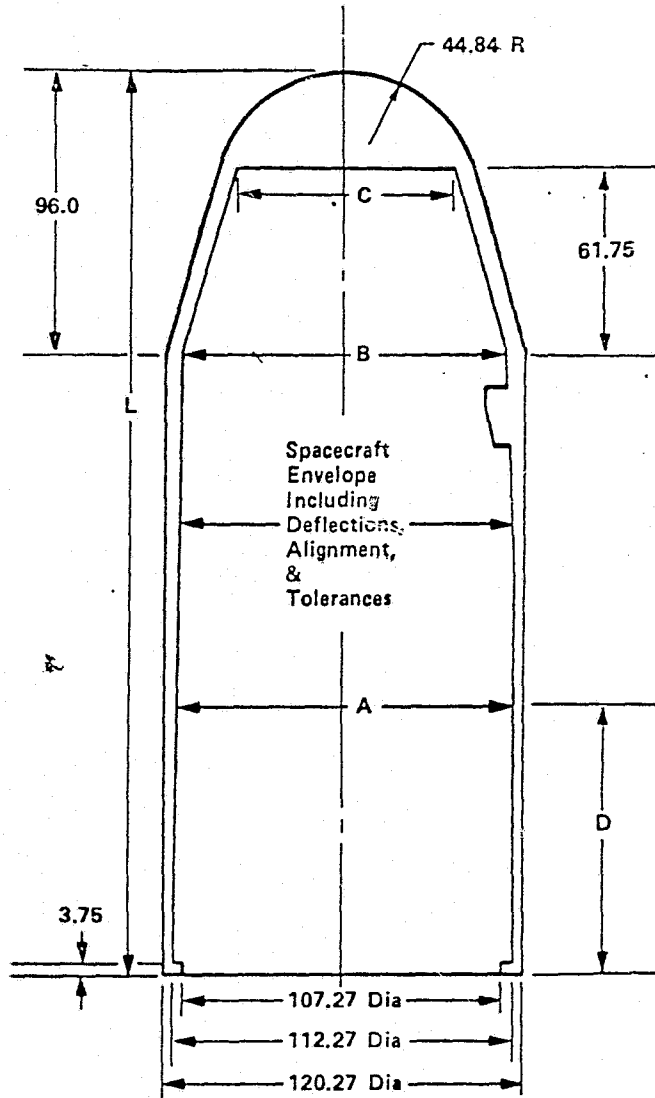

Figure 2-11. Titan III E with 5-m (16.7-ft) Diameter Lockheed Fairing



L, ft	Dimension, in.				
	L	A	B	C	D
15	180	112.3	112.3	78.9	84
20	240	111.7	111.7	78.3	144
25	300	111.6	111.1	77.7	144
30	360	111.5	110.3	76.8	144
35	420	111.3	108.7	75.2	144
40	480	111.2	107.3	73.7	144
45	540	111.1	106.5	72.9	144
50	600	111.1	104.3	69.8	144

Figure 2-12. Titan III Universal Payload Fairing (UPLF) Envelope

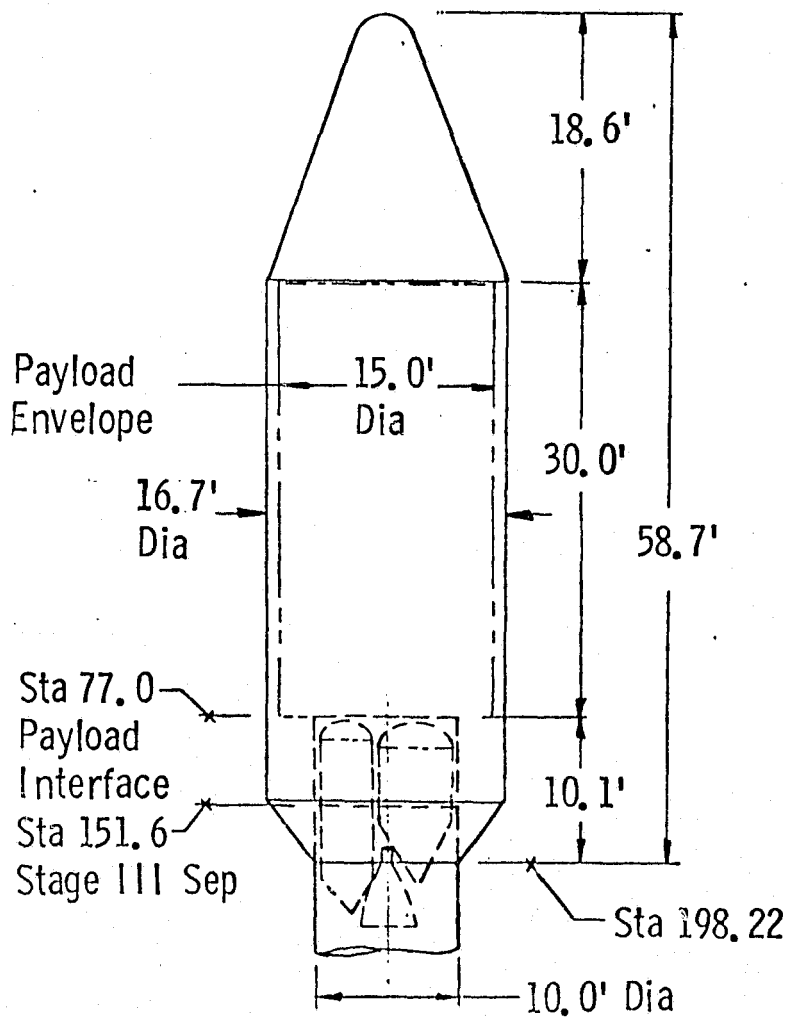

Figure 2-13. Titan IIC with 5-m (16.7-ft) Diameter McDonnell Douglas Fairing

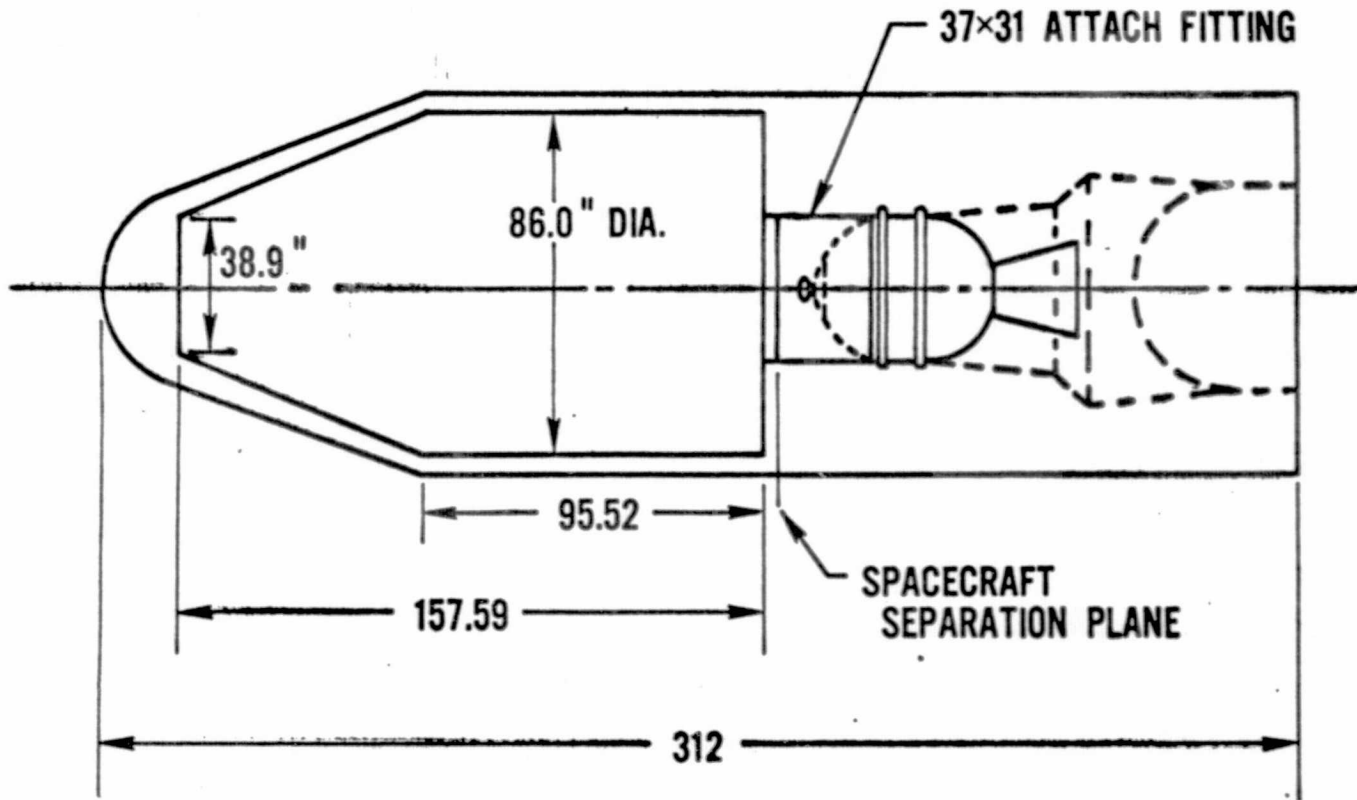

Figure 2-14. Delta 2914 Payload Envelope

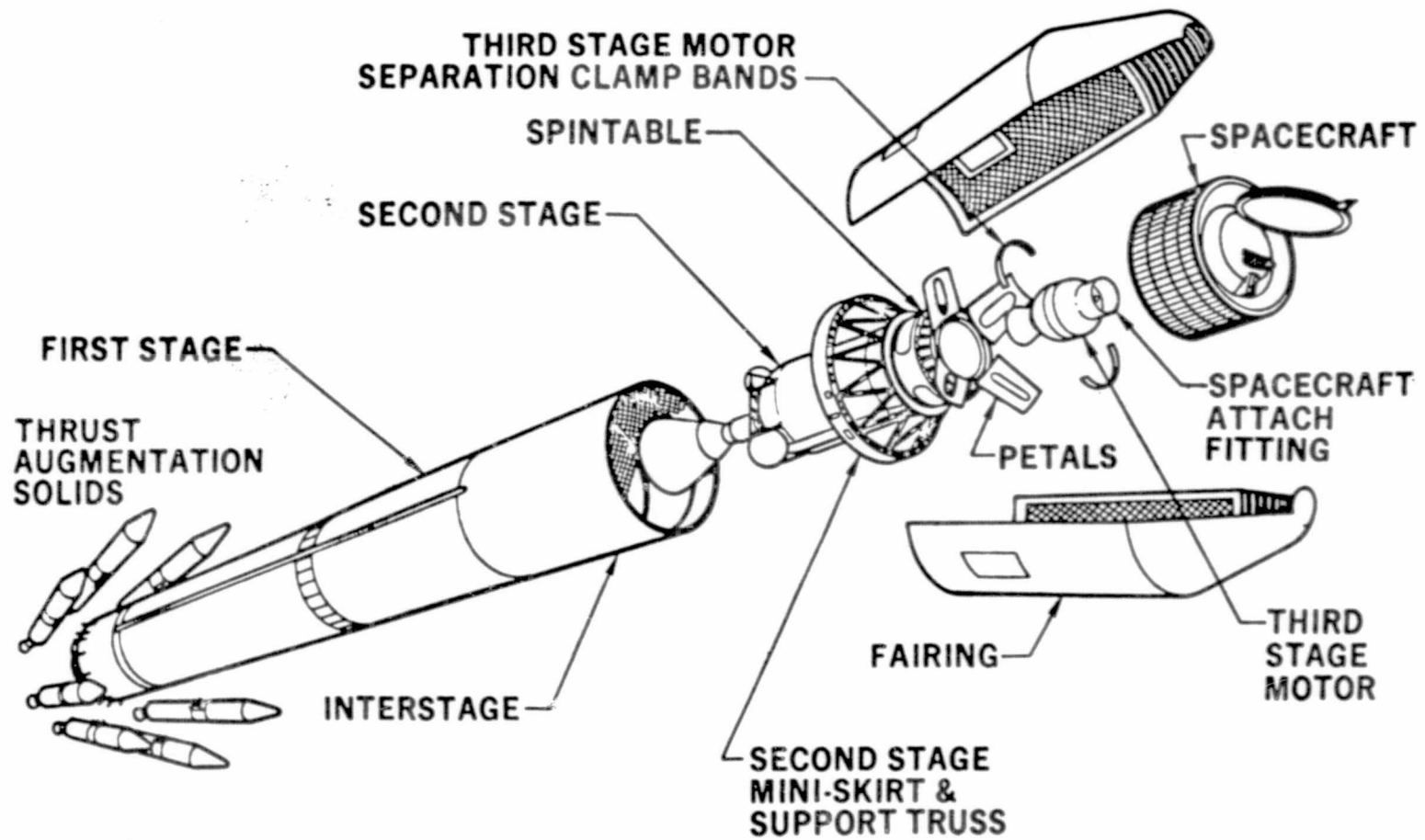

Figure 2-15. Delta Staging Schematic, Three-Stage Vehicle

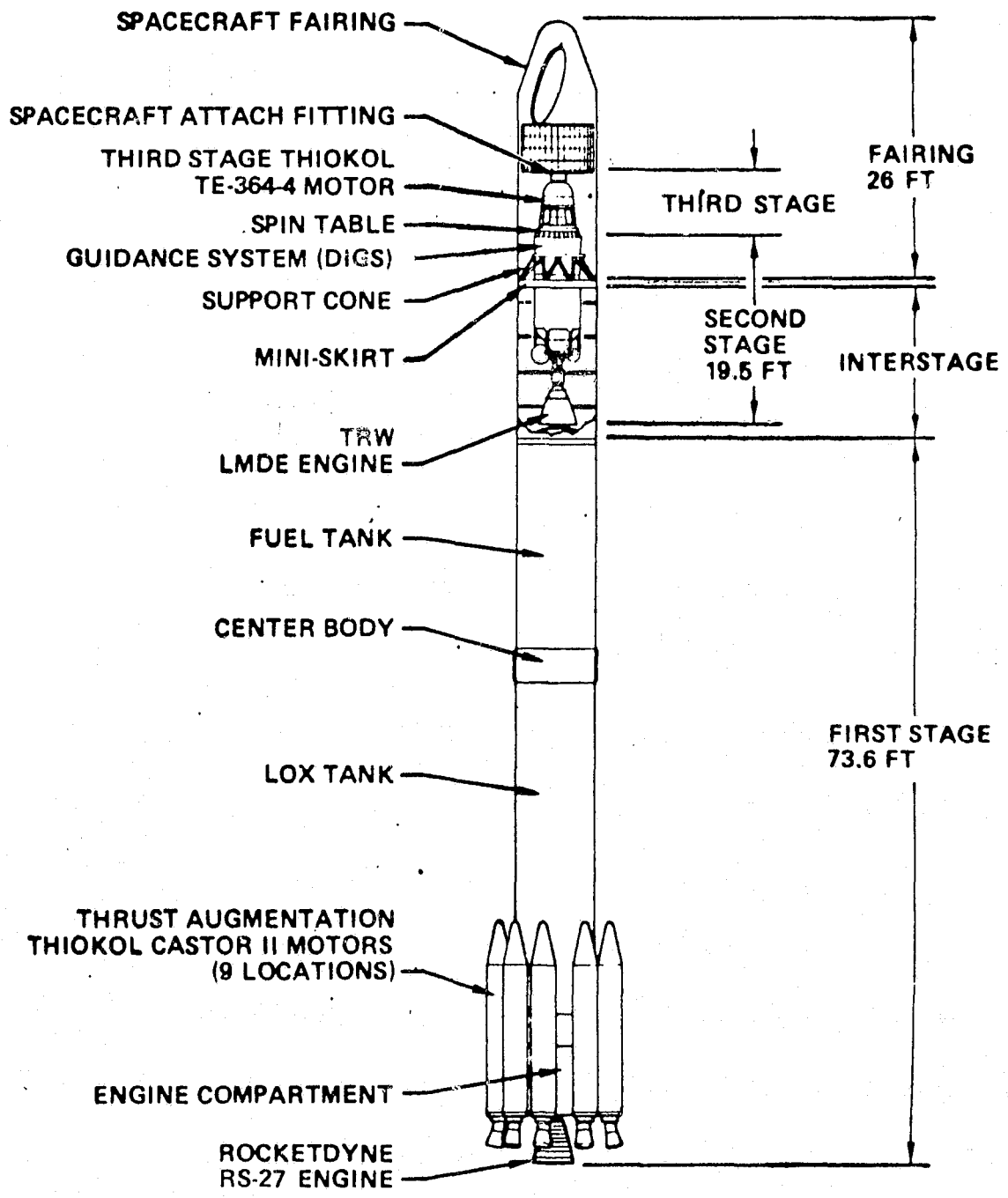

Figure 2-16. Delta 2914 Configuration

The EO-09A (EO-59A and EO-62A) satellite has the most demanding ELV capability requirement, primarily due to the volume and lateral dimensions of the satellite. It appears feasible, since it is a new satellite design, to design to a 3.8-m (12.5-ft) maximum diameter if the program plan calls for an ELV launch using the Titan IIIE/Centaur D-1T and the Viking payload fairing. The Viking payload fairing internal clearances are the constraining features. If these constraints should prove unacceptable, very preliminary studies of a 5-m (16.7-ft) outer diameter payload fairing having half of the payload volume of the STS Orbiter bay 4.57 m (15 ft) x 9.14 m (30 ft) have been done at SAMSO. These studies indicated conceptual feasibility and a rough order of magnitude cost of \$32 million for the development. The Titan IIIE/Centaur D-1T has acceptable injection accuracy into the final geosynchronous orbit, since these data are similar to the IUS accuracy. Titan IIIE/Centaur D-1T payload capability into geosynchronous orbit is approximately 3266 kg (7200 lb) with the present Viking payload fairing, and ample margin would be available, even with a larger and heavier 5-m payload fairing. These data are summarized in Table 2-27.

The EO-07A satellite is compatible without modification with the Titan IIIE/Centaur D-1T Viking payload fairing ELV. An additional option would be available if the EO-07A design was constrained to a 2.74-m (9-ft) diameter to be compatible with the Titan IIIC and its 3.05-m (10-ft) payload fairing. Preliminary studies have indicated the feasibility of flying a modified Viking payload fairing on the Titan IIIC at an estimated cost of \$4.5 million. Both ELVs have adequate payload capability and acceptable injection accuracy. These data are summarized in Table 2-28.

The AS-05A satellite SSPDA data envision a dual launch of two spacecraft side by side on the Tug. This requires a 3.66-m (12-ft) diameter by 2.44-m (18-ft) payload envelope for the dual side-by-side spacecraft. This configuration could be launched by a Titan IIIE/Centaur D-1T

Table 2-27. EO-09A ELV Options

- o EO-09A SSPDA Data-3250 lbs 11.8 x 13.45 x 19 ft long 8 Missions '83-'91
4 Missions '88-'90
4 Missions '88-'90
- o Titan III E/Centaur D-1T
Synchronous Equatorial Capability 7200 lbs
Viking Fairing Envelope 12.5 ft diameter x 24 ft long
usable length for these S/C 19.25 ft
Injection accuracies similar to IUS
- o Payload Fairing Mod not required if Spacecraft
Equipment section design change from present box structure
on end of telescope to circular structure around end of
telescope within 12.5 ft diameter.
- o Preliminary studies of a 16.7 ft outer diameter fairing providing
a 15 ft diameter x 30 ft envelope for TIII E/Centaur have indicated
a ROM Cost on the order of \$32M.
- o Spacecraft Design Similar to IUS.

Table 2-28. EO-07A ELV Options

- o EO-07A SSPDA Data 2743 lbs 9.5 x 9.8 x 12.8 ft long 3-Axis Single 1987 Mission
- o Titan III E/Centaur D-IT
 - Synchronous Equatorial Capability 7200 lbs
 - Viking Fairing Envelope 12.5 ft diameter x 19.25 ft usable
 - Injection errors similar to IUS
 - Payloads Compatible
- o TIIIC
 - Synchronous Equatorial Capability 3200 lbs
 - UPLF Envelope (25 ft version) 9 ft diameter x 17 ft length
 - Injection errors similar to IUS
 - Payload would require repackaging of structure to reduce diameter to 9 ft which appears feasible
 - Alternatively preliminary studies indicate that the Viking Fairing could integrate on the TIIIC at a ROM Cost of the order of \$4.5 M.
- o Spacecraft Design Similar to IUS

using the Viking payload fairing. A second option is possible if the satellites are designed to be stacked one atop the other to fit with the Titan IIIC 3.05-m (10-ft) payload fairing. Such a stack would be 1.83 m (6 ft) in diameter by 5.18 m (17 ft) and is similar to the concept used in launching two Defense Satellite Communications System II satellites on Titan IIIC now. Both vehicles have adequate payload capability and accuracy. These data are summarized in Table 2-29.

The EO-57A and EO-58A designs are fully compatible with the Delta 2914 launch vehicle. These satellites nominally weigh 257 kg (566 lb), are 1.91 m (6.27 ft) in diameter by 3.14 m (10.3 ft) in length, and are spin stabilized at 100 rpm. The Delta 2914 ELV has a payload capability of 331 kg (730 lb) and a payload envelope of 2.16 m (7.1 ft) in diameter and 2.36 to 4.57 m (7.75 to 15 ft) in length using the payload fairing nose volume (at reduced diameter). The EO-57A and EO-58A satellite designs appear to be evolutionary or identical designs to the SMS/GOES with on-orbit weights of 286 kg (630 lb) and flown on Delta 2914 ELVs with a 100-rpm spin stabilization. The Delta injection accuracy is similar to that of the SSUS and considerably less accurate than the Tug/IUS requiring more orbit correction delta velocity to be provided in the satellite. Table 2-30 summarizes these data.

2.4 STABILIZATION AND CONTROL OF SPIN-STABILIZED SATELLITES

The two spin-stabilized satellites which were considered for purposes of the SSUS study were extensions of a current spin-stabilized satellite, the Synchronous Meteorological Satellite (SMS). The EO-57-A Foreign Synchronous Meteorological Satellite (FSMS) and the EO-58-A Geosynchronous Operational Meteorological Satellite (GOMS) are nearly identical to each other and represent an operational version of the SMS, a NASA meteorological research and development satellite. The NASA-supplied Level A and Level B data are virtually identical to the SMS data on hand with only minor exceptions.

Table 2-29. AS-05A ELV Options

- o AS-05A SSPDA Data 2644 lbs (Pair launch) 12 ft diameter x 8 ft long Single 1981
1322 lbs (Single S/C) 6 ft diameter x 8 ft long Mission
3-Axis
- o Titan III E/Centaur D-IT
Synchronous Equatorial Capability 7200 lbs
Viking Fairing Envelope 12.5 ft diameter x 19.25 ft
Injection accuracy similar to IUS
Payloads compatible Side-by-Side dual configuration
- o Titan III C
Synchronous Equatorial Compatibility 3200 lbs
UPLF Envelope (25 ft version) 9 ft diameter x 17 ft length
Injection accuracy similar to IUS
- Payloads would have to be launched in a dual tandem configuration with a truss around the lower spacecraft or by redesign of the spacecraft to carry the loads of the upper spacecraft similar to DSCS II (Program 777).
- Alternatively preliminary studies indicate that the Viking Fairing could be integrated on the III C at a ROM Cost of the order of \$4.5M.
- o Spacecraft Design Similar to IUS

Table 2-30. EO-57A/58A ELV Options

- o EO-57A SSPDA Data 566 lbs 6.27 ft diameter x 10.3 ft long 6 Missions '81-'91
- EO-58A 100 rpm Spin 8 Missions '81-'91

- o Delta 2914 Synchronous Transfer Capability (Spin) 1550 lbs
Synchronous Equatorial Capability (Spin) 730 lbs
Delta Fairing Envelope 7.1 ft dia x 7.75 to 15 ft (Nose Section)
Injection errors greater than IUS comparable to SSUS

- Payload compatible

- o EO-57A and EO-59A SSPDA data presently identical to SMS/GOES
Satellite currently flown on Delta 2914 Spacecraft/AKM weighs 1385 lbs
on orbit weight 630 lbs.

- o Spacecraft Design Similar to IUS and SSUS

The basic guidance, navigation, and stabilization (G, N, and S) configuration is shown in Figure 2-17 and Table 2-31, respectively, for a Tug-deployed version. As noted in the figure, two nutation sensors as well as logic in the attitude determination and control (ADAC) electronics unit have been added for an expendable version. This version is in fact the original SMS. The nutation sensors and logic are required for active nutation control during the transfer orbit from the Shuttle to synchronous altitude or for an expendable version from the Delta 2914.

The payload is a spin-scan, visible infrared radiometer/sounder, which has been optimized for scanning at 100 rpm. Thus, the vehicle must be stable on-orbit operationally to minimize fuel expenditure. Spin stabilization at 100 rpm can provide the scan, provided the vehicle is stable. To attain stability, the roll inertia must be greater than the transverse inertia. This configuration leads to a disc-shaped body operationally. However, the addition of a solid rocket motor for apogee kick from a transfer orbit forces the configuration to be long and slender, or the transverse inertia becomes greater than the roll inertia. In either case, the body ultimately ends in a minimum energy state when energy is dissipated. That is, the vehicle will exhibit pure rotation about the axis of largest inertia. Thus, in the transfer orbit, the SMS is unstable, and operationally in the final synchronous orbit after separation of the apogee kick motor, the satellite is stable. Therefore, it is in the transfer orbit where some means must be provided to maintain stability.

In the final orbit, energy dissipation is provided deliberately in the form of a passive nutation damper (Figure 2-18). This damper reduces any disturbance-induced nutation to a negligible value.

One simple, inexpensive technique for stabilization during the transfer orbit is the use of an active nutation control system. In this scheme, a linear accelerometer is mounted nominally 90 deg from the control jet. Accelerometer lags and valve delays account for a few degrees

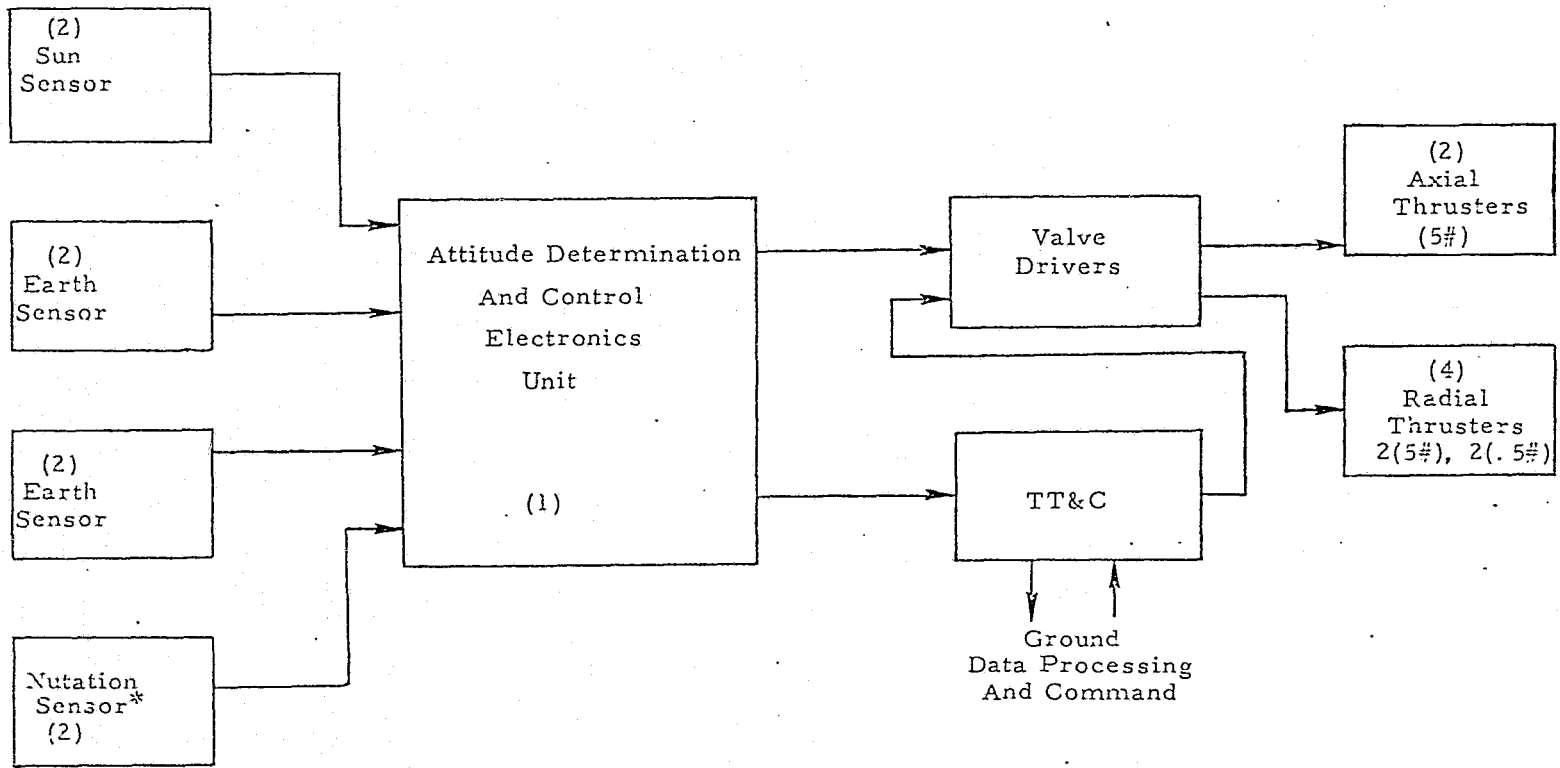

* Added for SSUS, Expendable 2914

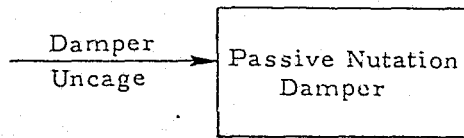

Figure 2-17. Basic Tug-Type G, N, and S System for an SMS-Type Spacecraft

Table 2-31. Basic Tug-Type G, N, and S System
Weight and Power Estimate

	Weight			Power, Watts (Total)	
	kg	lb		Peak (ea)	Average
Sun Sensor (2)	0.36	0.80	From ADAC	0.03	0.008
Earth Sensor (4)	3.18	7.00	From ADAC	0.66	NA
Nutation Sensor (2)*	0.50	1.10	From ADAC	0.30	NA
Passive Nutation Damper	1.54	3.40		-	-
ADAC Electronics Unit (Redundant)	6.80	15.00		12.9	7.750
Valve Drive Assembly	0.83	1.84		35.2	-
Total	12.72	28.04			7.750
Total*	13.22	29.14			

* Added for SSUS, Expendable Delta 2914

ALIGNMENTS

- $\theta_{12} = 0 \pm 0.5 \text{ deg}$
- $\theta_{13} = 0 \pm 2 \text{ arc min}$
- $\theta_{23} = 0 \pm 1 \text{ deg}$
- $X = 0 \pm 0.02 \text{ in.}$

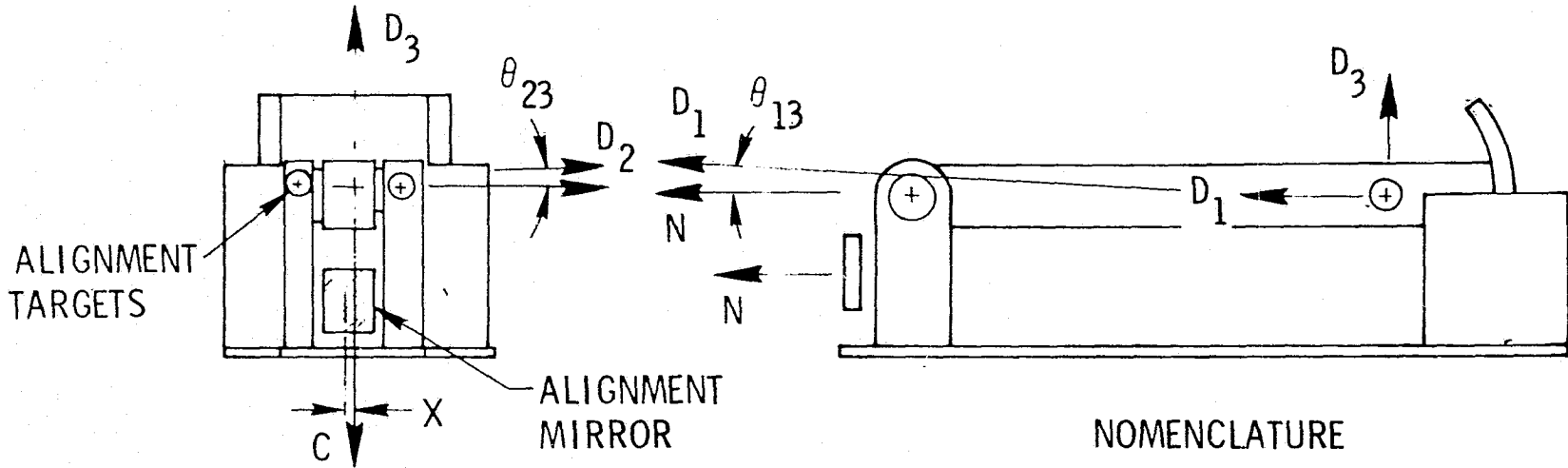
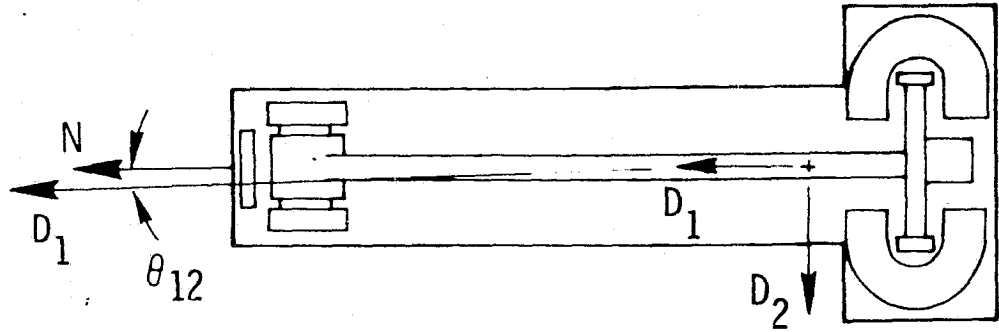

NOMENCLATURE

- N - MIRROR NORMAL
- T - TARGET BULL'S EYE
- C - MIRROR CENTER LINE
- D - PRINCIPAL DAMPER AXIS

Figure 2-18. Passive Nutation Damper

displacement away from nominal. The accelerometer used as an inexpensive rate gyro without the inherent drift problems of gyros. When the body rate, as sensed by the accelerometer, exceeds a threshold fixed by the maximum permissible nutation angle, the thruster is turned on until the rate drops below the threshold. Figure 2-19 shows such a system with two thresholds. The system is not activated until the peak rate is greater than a threshold. As shown, the thruster turns on during the time the rate is greater than half the threshold. The effect is to damp the rate until the rate is less than half the threshold. The system is then deactivated until the rate reaches the original threshold, and the system becomes reactivated. Thus, the rate cycles between the two thresholds. Therefore, the maximum and minimum body rate and nutation angle as related to the rate can be controlled.

2.5

STABILIZATION AND CONTROL OF
THREE-AXIS-STABILIZED SATELLITES

The three-axis-stabilized satellites which were considered for purposes of the SSUS study were defined at the beginning of the task as:

- a. EO-09A Synchronous Earth Observatory Satellite
- b. EO-59A Geosynchronous Earth Resource Satellite
- c. EO-62A Foreign Synchronous Earth Observatory Satellite
- d. AS-05A Advanced Radio Astronomy Explorer
- e. EO-07A Advanced Synchronous Meteorological Satellite.

The EO-09A, EO-59A, and EO-62A satellites were nearly identical in definition and, hence, were treated as a single entity with the EO-09A satellite selected to typify the group. The AS-05A and EO-07A satellites were treated separately.

Since, by definition, the three-axis-stabilized satellites are non-rotating in their orbital role, it seemed logical to explore whether the satellite could be maintained non-rotating and yet utilize a spinning injection stage. The EO-09A satellite was selected for purposes of examining this option.

ARRANGEMENT OF ACTIVE
NUTATION CONTROL SYSTEM
COMPONENTS (schematic)

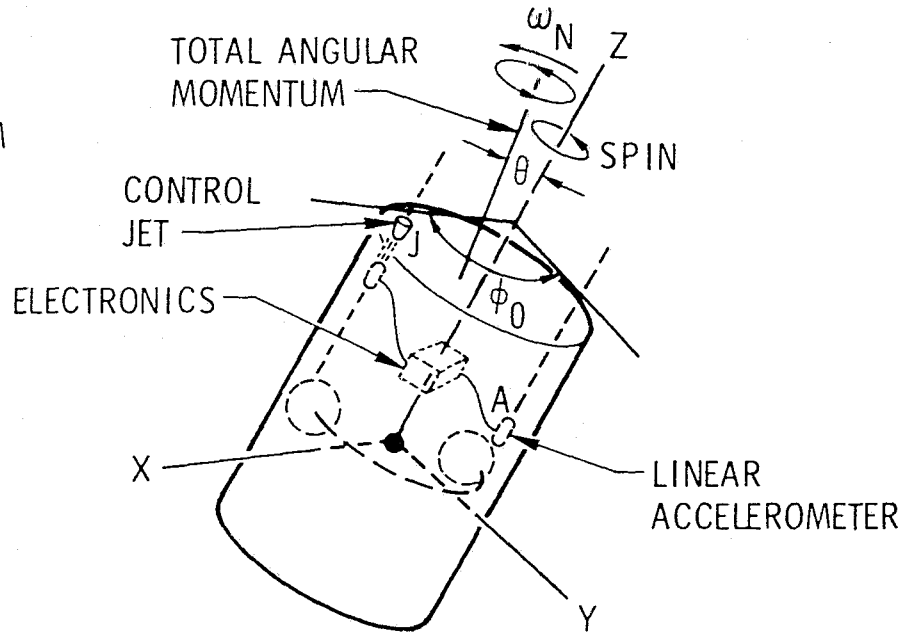

TYPICAL
NUTATION
DAMPING

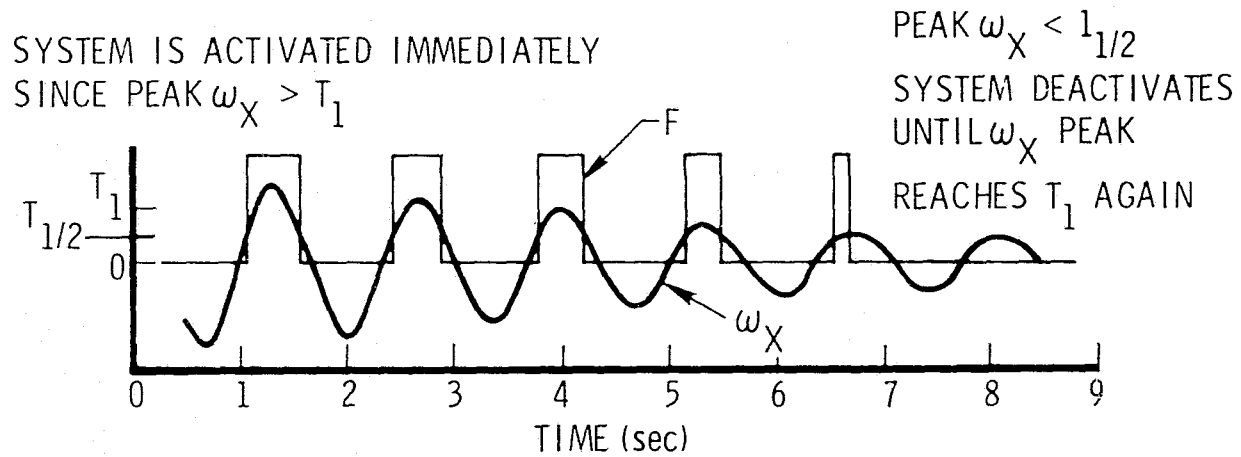

Figure 2-19. Active Nutation Control System

In order to examine the impact of adapting a satellite for use with an SSUS, the NASA-supplied Level A and Level B payload data sheets were studied to obtain an understanding of the guidance and control system requirements. This information was then translated into a baseline guidance and control system for the EO-09A, AS-05A and EO-07A satellites. These baseline configurations are shown in Figures 2-20, 2-21, and 2-22 and in Tables 2-32, 2-33, and 2-34 respectively. The baseline guidance and control systems are configured for use with a Tug, but remain unchanged if employed with an IUS or an ELV.

The first option which was examined was the EO-09A satellite mated with an SSUS via a despin bearing assembly. Table 2-35 contains the mass properties of the EO-09A satellite at beginning, end, and mid-point of the perigee and apogee kick motor burns. It was assumed that the platform (EO-09A satellite) was completely despun, and the rotor (the kick motors) was spinning at 30 rpm for perigee burn and 100 rpm for apogee burn.

For the dual-spin configuration, stability requirements dictate that:

$$\left| \dot{T}_P \right| > \left[\frac{I_R}{I_T} \left(\frac{\dot{T}_R}{\frac{I_R}{I_T} - 1} \right) \right]$$

where \dot{T}_P and \dot{T}_R are the energy dissipation rates for the platform and rotor, respectively, and the platform rate is assumed to be zero. I_R and I_T are as defined in Table 2-35.

2-2

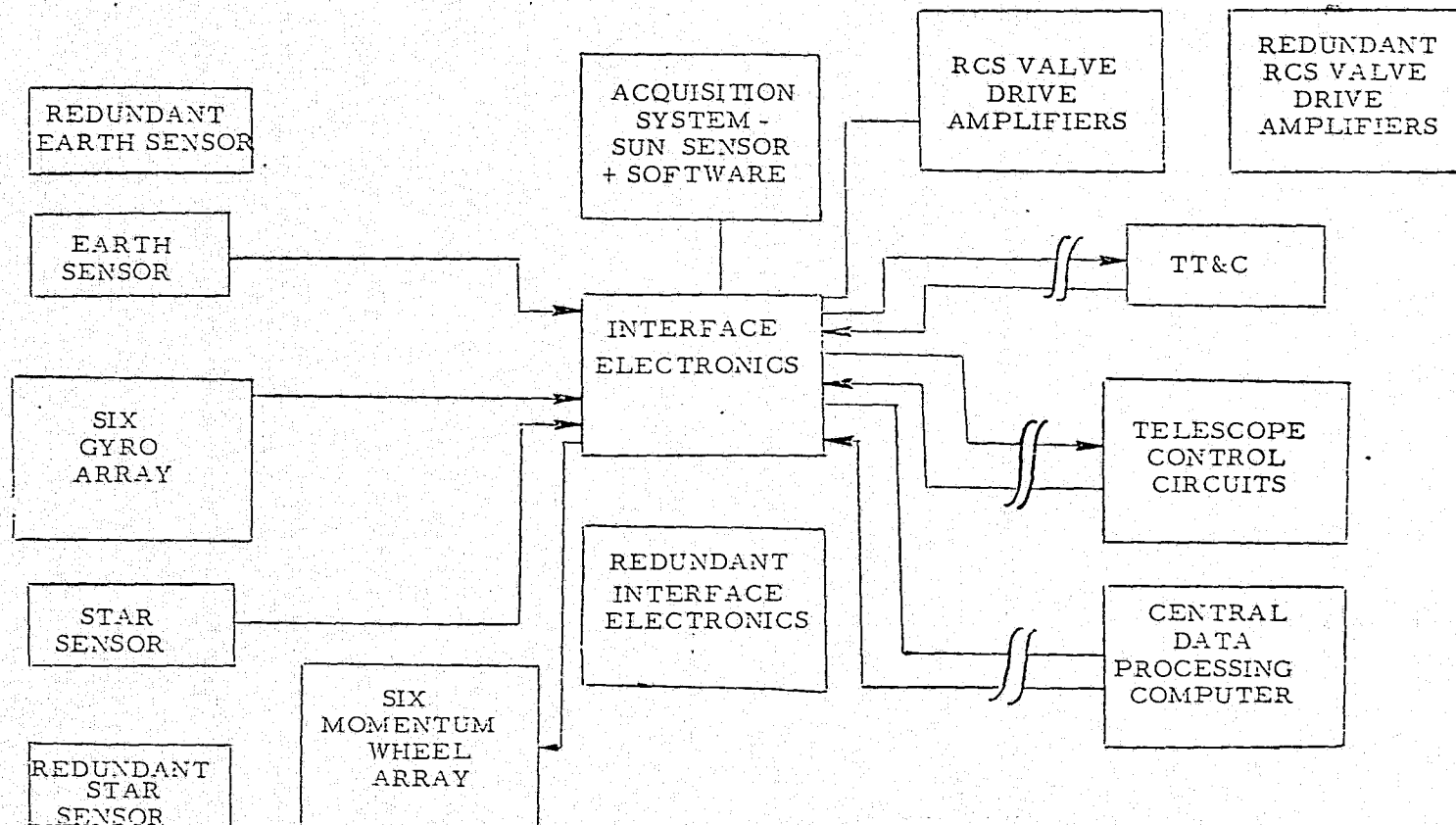

2-65

Figure 2-20. Basic Three-Axis Tug-Type G, N, and S System for SEOS-Type Spacecraft (EO-9A)

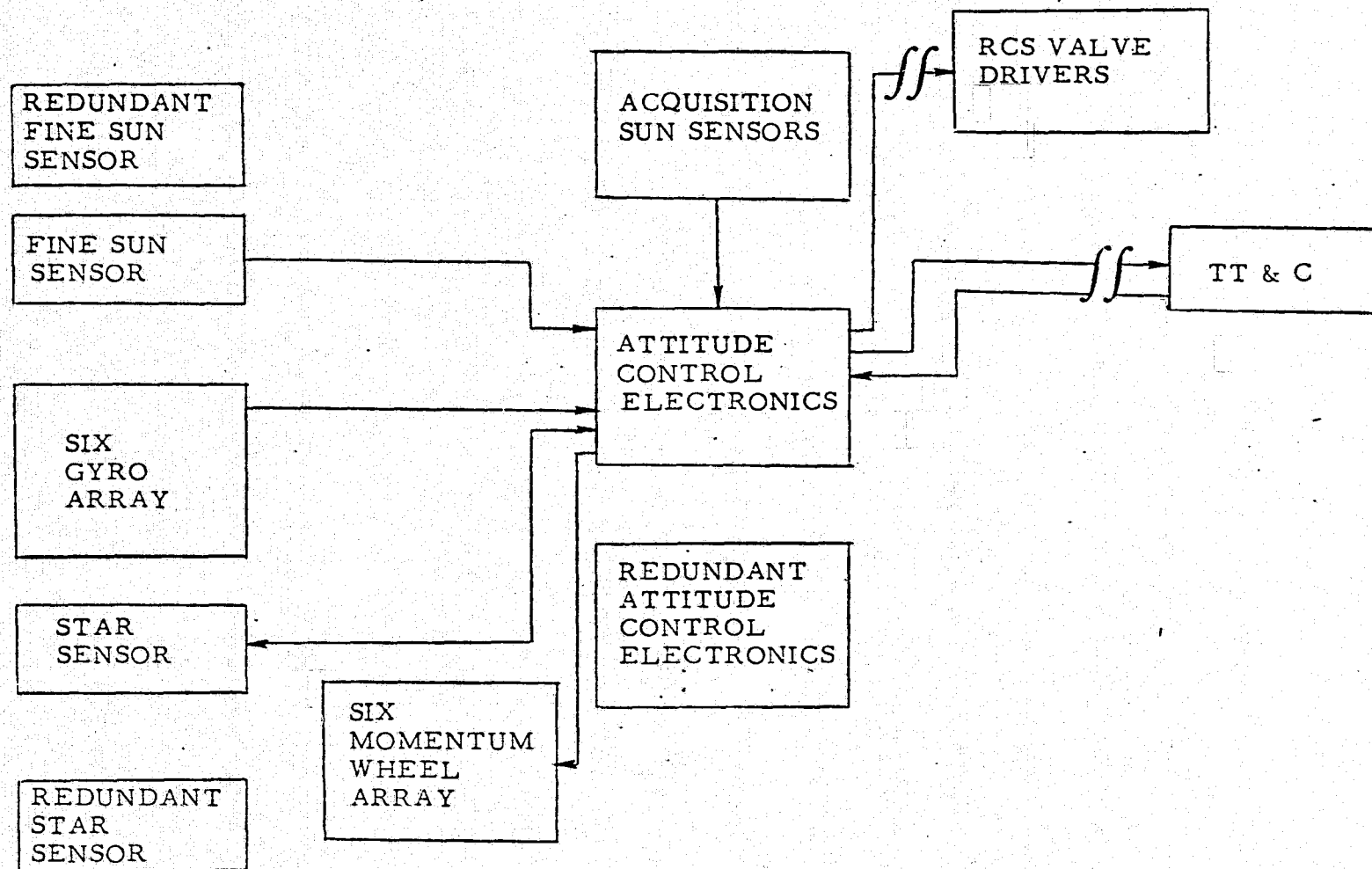

Figure 2-21. Basic Three-Axis Tug-Type G, N, and S System for Radio-Astronomy-Type Spacecraft (AS-05A)

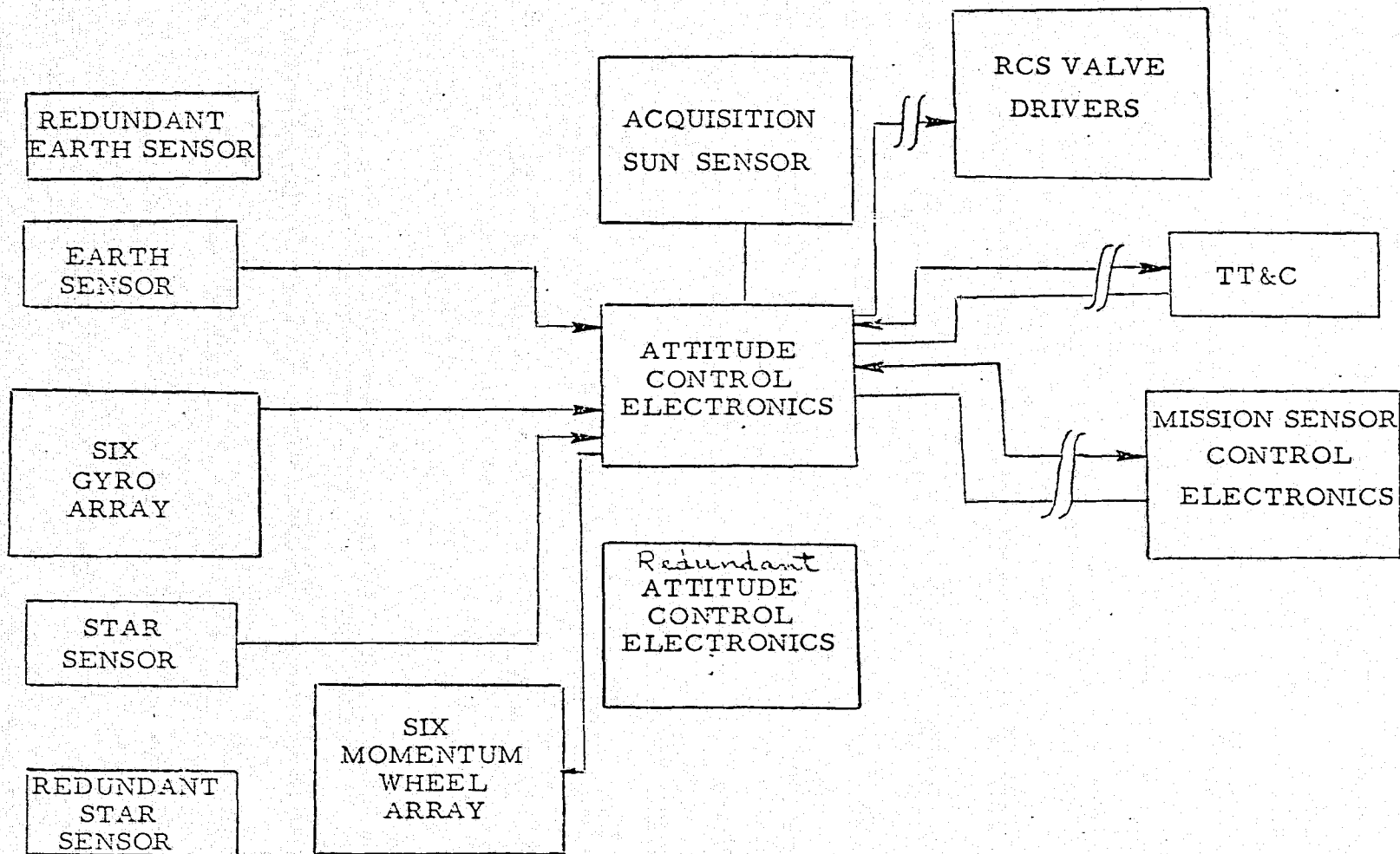

Figure 2-22. Basic Three-Axis Tug-Type G, N, and S System for Synchronous-Meteorological-Type Spacecraft (EO-07A)

Table 2-32. Basic Three-Axis Tug-Type G, N, and S System (EO-09A)
Weight and Power Estimate

Equipment	Weight, kg (lb)				Power, Watts	
	Unit		Total		Peak	Average
Earth Sensor	5.90	(13.0)	11.79	(26.0)	10.0	10
Sun Sensor	0.14	(0.3)	0.64	(0.3)	0.5	≈0
Star Sensor	4.54	(10.0)	9.08	(20.0)	8.0	8
6-Gyro Array	14.52	(32.0)	14.54	(32.0)	45.0	30
6-Momentum Wheel Array	46.29	(102.0)	46.27	(102.0)	97.0	20
Interface Electronics	6.35	(14.0)	12.7	(28.0)	15.0	15
Acquisition	0.91	(2.0)	0.91	(2.0)	1.5	≈0
Drive Amplifiers	1.36	(3.0)	2.72	(6.0)	3.0	3
	<u>80.01</u>	<u>(176.3)</u>	<u>98.11</u>	<u>(216.3)</u>	<u>180.0</u>	<u>86</u>

Source

Earth Sensor - TRW Applications Technology Satellite F (ATS-F)

Sun Sensor - Adcole

Star Sensor - ATS-F

6-Gyro Array - IUE

Momentum Wheel - Bendix OGO Yaw Reaction Wheel

Interface Electronics - IUE-derived

Table 2-33. Basic Three-Axis Tug-Type G, N, and S System (AS-05A)
Weight and Power Estimate

Equipment	Weight, kg (lb)				Power, Watts
	Unit		Total		Average
Fine Sun Sensor	2.90	(6.4)	5.81	(12.8)	1.7
6-Gyro Array	14.52	(32.0)	14.52	(32.0)	30.0
6-Momentum Wheel Array	14.70	(32.4)	14.70	(32.4)	9.0
Star Sensor	4.54	(10.0)	9.07	(20.0)	8.0
Attitude Control Electronics	11.11	(24.5)	22.23	(49.0)	18.0
Acquisition Sun Sensors	<u>0.14</u>	<u>(0.3)</u>	<u>0.14</u>	<u>(0.3)</u>	<u>---</u>
	47.91	(105.6)	66.47	(146.54)	66.7
<u>Source</u>					
Fine Sun Sensor	- IUE				
6-Gyro Array	- IUE				
6-Momentum Wheel Array	- IUE derived				
Star Sensor	- ATS-F				
Attitude Control Electronics	- Flight Control Electronics Assembly (LMSC)				
Acquisition Sun Sensors	- IUE				

Table 2-34. Basis Three-Axis Tug-Type G, N, and S System (EO-07A)
Weight and Power Estimate

Equipment	Weight, kg (lb)		Power, Watts	
	Unit	Total	Peak	Average
Earth Sensor	5.90 (13.0)	11.79 (26.0)	10	10
6-Gyro Array	14.52 (32.0)	14.52 (32.0)	45	30
Star Sensor	4.54 (10.0)	9.07 (20.0)	8	8
6-Momentum Wheel Array	46.27 (102.0)	46.27 (102.0)	97	20
Acquisition Sun Sensors	0.14 (0.3)	0.14 (0.3)	---	---
Attitude Control Electronics	11.11 (24.5)	22.23 (49.0)	33	18
	<u>82.48 (181.84)</u>	<u>104.02 (229.32)</u>		

Source

Earth Sensor - TRW

6-Gyro Array - IUE

Star Sensor - ATS-F

6-Momentum Wheel Array - Bendix OGO Wheel

Acquisition Sun Sensors - IUE

Attitude Control Electronics - Flight Control Electronics Assembly (LMSC)

Valve Drive Amplifiers - Estimated

Table 2-35. SSUS Dual-Spin EO-09A Mass Properties

	H_S (ft-lb-sec)	I_R (Sl-ft ²)	I_P (Sl-ft ²)	M_R (lb)	M_P (lb)	I_t (Sl-ft ²)
Start of Perigee Burn (30 rpm)	6487	2065	1638	16395	3760	16876
End of Perigee Burn	1288	410	1638	4877	3760	8329
Midpoint Perigee Burn	3888	1238	1638	10636	3760	12603
Start Apogee Burn (100 rpm)	2367	226	1638	3597	3760	5980
End Apogee Burn	230	22	1638	360	3760	3967
Midpoint Apogee Burn	1300	124	1638	1979	3760	4974

H_S = Total system angular momentum	M_R = Rotor mass
I_R = Rotor spin inertia	M_P = Platform mass
I_P = Platform spin inertia	I_t = Total transverse inertia

For the EO-09A system under consideration, the stability conditions are:

$$\left| \dot{T}_P \right| > .14 \quad \left| \dot{T}_R \right| \quad \text{Beginning of perigee burn}$$

$$\left| \dot{T}_P \right| > .05 \quad \left| \dot{T}_R \right| \quad \text{End of perigee burn}$$

$$\left| \dot{T}_P \right| > .04 \quad \left| \dot{T}_R \right| \quad \text{Beginning of apogee burn}$$

$$\left| \dot{T}_P \right| > .0056 \left| \dot{T}_R \right| \quad \text{End of apogee burn}$$

From the above, it is clear that the dual-spin configuration described is stable, given only moderate energy dissipation on the platform via a passive nutation damper.

The major problem associated with open-loop thrusting of a dual-spin configuration is that center of gravity (c. g.) offsets (with respect to the spin axis) in the despun section result in constant precession torques on the vehicle. Thus, the average thrust vector of the spinning section is biased off in a constant direction in platform coordinates when a platform c. g. offset exists.

The precession rate due to a constant despun body torque is

$$\omega = \frac{Fl}{H_S}$$

where

F = Average thrust vector

l = Offset of thrust vector with system c. g. (If average thrust vector passes through spin c. g., this is due entirely to the platform c. g. offset.)

The inertial acceleration is

$a_N = F/M \sin \omega t$ = acceleration normal to desired velocity vector

$a_t = F/M \cos \omega t$ = acceleration in direction of desired velocity vector

Assuming constant mass (the midvalue for each burn)

$$v_N = \frac{F}{M\omega} (1 - \cos \omega t_b)$$

$$v_t = \frac{F}{M\omega} \sin \omega t_b$$

t_b = burn time

Now the desired velocity change is

$$v_N = 0, v_t = \frac{F}{M} t_b$$

The velocity errors are, therefore,

$$\Delta V_N = \frac{H_S}{M_P \ell_P} F \left(1 - \cos \frac{F}{H_S} \frac{M_P \ell_P}{M_P + M_R} t_b \right)$$

$$\Delta V_t = \frac{F t_b}{M_P + M_R} - \frac{H_S}{M_P \ell_P} F \sin \frac{F}{H_S} \frac{M_P}{M_P + M_R} \ell_P t_b$$

$$\Delta V_e = \left(\Delta V_N^2 + \Delta V_t^2 \right)^{1/2}$$

where $\ell_P = M_P + M_R / M_P$ ℓ = platform c. g. with respect to spin axis.

For Perigee Burn

F = 25,000 lb, desired velocity = 8000 ft/sec, use midburn values of Table 2-35.

ℓ_P (in.)	ΔV_N (ft/sec)	ΔV_t (ft/sec)	ΔV_e (ft/sec)	ωt_b (deg)
0.000	0.0	0.00	0.0	0.00
0.001	80.1	0.52	80.1	1.15
0.010	798.2	53.30	800.0	11.47
0.1000	5666.4	4371.00	7156.0	114.70

For Apogee Burn

F = 9500 lb, desired velocity = 4850 ft/sec, use midburn values of Table 2-35.

<u>l_P</u> (in.)	<u>ΔV_N</u> (ft/sec)	<u>ΔV_t</u> (ft/sec)	<u>ΔV_e</u> (ft/sec)	<u>ωt_b</u> (deg)
0.000	0.0	0.00	0.0	0.00
0.001	88.0	1.05	88.0	2.08
0.010	870.7	105.80	877.1	20.80
0.100	2515.5	5477.30	6027.3	208.00

From the above, it is clear that very small c. g. offsets of the platform create extremely large, and intolerable, velocity errors.

One way of countering the large precession torque would be the brute force approach of having large thrusters directly counter the precession torque. For a c. g. offset of 0.64/cm (0.25 in.), a set of four large thrusters of about 336.60n - 400.32n (75 - 90 lb) each would be required, and additional hydrazine weight of 38.56 - 45.36kg (85 - 100 lb) would be required. The spacecraft attitude sensors would have to be augmented, since the look angles of the existing baseline sensors would not suffice. A sun aspect sensor mounted on the despun satellite and looking normal to the SSUS spin axis would be needed. In addition, a pipper-type horizon sensor mounted on the SSUS would be needed for attitude determination purposes, and a passive nutation damping system would be required, as was indicated earlier. Thus, while this brute force control approach is possible to perform, it does not appear to have many redeeming features.

Before proceeding to the full-spinning-injection case, another case appeared reasonable to examine. That case is one wherein the kick motors rotate as before, but the platform is allowed to rotate at some fraction of the rotor speed. The rationale for examining this case at all must be predicated on the premise that the satellite would be incapable of surviving the fully-spinning injection due to the magnitude of the centrifugal loads

imposed, but could survive the centrifugal loads imposed by the partial spin speed. This is a remote and somewhat pathological case, and, hence, not a great deal of time was devoted to it.

Rotating the platform permits the c. g. offset to be inertially cyclic, and the velocity vector error becomes bounded. An equation for the steady-state velocity vector error given no initial angular offsets is:

$$l_P = (H_S - I_R \Omega) \frac{H_S}{I_P + I_R} \frac{M_P + M_R}{M_P F} \delta \quad (1)$$

where

δ = Steady-state injection velocity vector error,

$\Omega = \omega_R - \omega_P$ = relative spin rate between rotor and platform

P = platform c. g. offset with respect to the spin axis

These equations assume that H_S and M_R remain constant during the burn. Since this is not true, Equation 1 is evaluated at the beginning, midpoint, and end of the burn to scope the problem. There is a resonant condition that must be avoided which is defined by

$$H_o = I_P \omega_P + I_R \omega_R - I_t \omega_P = 0$$

$$\Omega_o = \frac{I_t - I_P - I_R}{I_R I_t} H_S \quad (2)$$

Assuming $\omega_R > \omega_P$, when $\Omega < \Omega_o$, the system is dynamically unstable without active nutation control

Figure 2-23 shows the midburn perigee and apogee plots of Equation 1. Table 2-36 gives the numerical values for Equation 1 at beginning, midpoint, and end of burn for both cases. The ΔV_e injection error is computed as

$$\Delta V_e = V_{nom} \delta$$

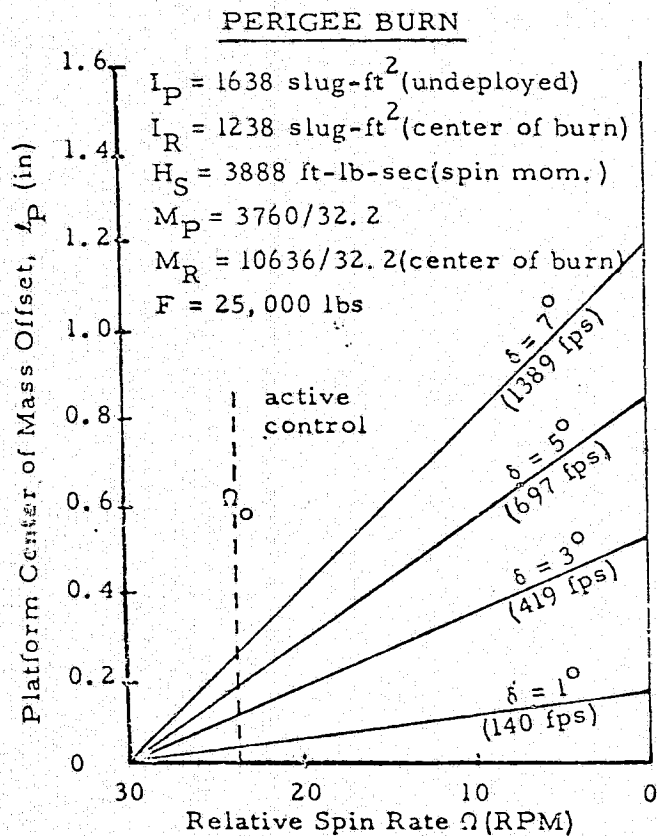

100% Platform Despin
 $(\omega_R = 3.14 \ \omega_P = 0)$

100% Platform Spinup
 $(\omega_R = \omega_P = 1.35 \text{ rad/sec})$

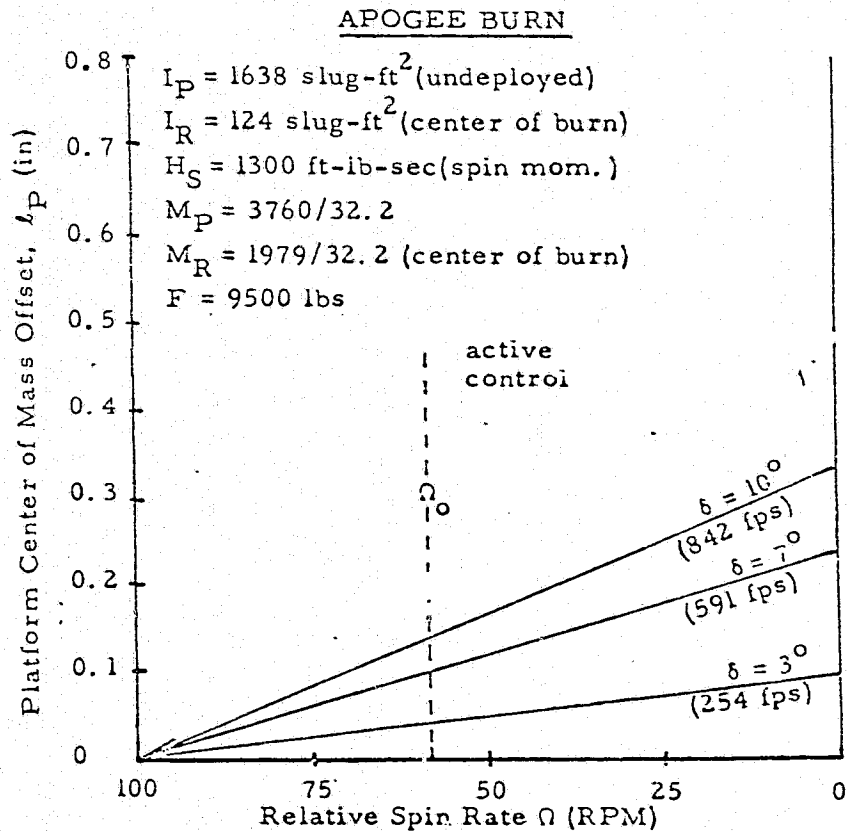

100% Platform Despin
 $(\omega_R = 10.5 \ \omega_P = 0)$

100% Platform Spinup
 $(\omega_R = \omega_P = 0.74 \text{ rad/sec})$

Figure 2-23. Despun Platform (SEOS-Type)

ORIGINAL PAGE IS
OF POOR QUALITY

Table 2-36. Steady-State Angular Velocity Error,
for Rotating Platform

For Perigee Burn

$$l_P = \text{feet}, \Omega = \text{rad/sec}, \delta = \text{rad}$$

1. Beginning of Burn
 $l_P = (2.44 - .77 \Omega) \delta \quad \Omega_0 = 23.4 \text{ rpm}$
2. End of Burn
 $l_P = (.074 - .024 \Omega) \delta \quad \Omega_0 = 22.6 \text{ rpm}$
3. Midpoint of Burn
 $l_P = (.8 - .256 \Omega) \delta \quad \Omega_0 = 23.1 \text{ rpm}$

For Apogee Burn

4. Beginning of Burn
 $l_P = (.62 - .059 \Omega) \delta \quad \Omega_0 = 68.8 \text{ rpm}$
5. End of Burn
 $l_P = (.0037 - .00035 \Omega) \delta \quad \Omega_0 = 58.1 \text{ rpm}$
6. Midpoint of Burn
 $l_P = (.154 - .015 \Omega) \delta \quad \Omega_0 = 64.6 \text{ rpm}$

Case	Ω_0 (rpm)	ω_P (rpm)	ω_R (rpm)	δ (deg)	ΔV_e (fps)	$l_P @ \Omega_0$ (in)
1	23.4	3.68	27.9	1	140	.105
2	22.6	1.48	24.1	1	140	.004
3	23.1	2.96	26.1	1	140	.037
4	68.8	3.78	72.6	1	84.6	.12
5	58.1	.55	58.6	1	84.6	7.7×10^{-4}
6	64.6	2.50	67.1	1	84.6	.03

By spinning completely up for perigee burn ($\Omega = 0$), larger platform c. g. offsets can be tolerated (see Figure 2-23), but the system is dynamically unstable. This can be tolerated for the burn but not for the coast period.

The apogee burn situation is worse, due to small H_S from the spinning AKM. One technique is to add a momentum wheel to the AKM. This modifies Equations 1 and 2 to

$$\ell_P = (H_S - I_R \Omega) \frac{(H_S + h_w)}{I_P + I_R} \frac{M_P + M_R}{M_P F} \delta \quad (3)$$

$$\Omega_o = \frac{I_t - I_P - I_R}{I_R I_t} H_S - \frac{h_w (I_P + I_R)}{I_R I_t} \quad (4)$$

where h_w is the angular momentum of the wheel (defined positive in the same sense as H_S). Table 2-37 repeats cases 4, 5, and 6 of Table 2-36 with $h_w = 2000$ ft-lb-sec. The improvements are not very dramatic.

From all of the foregoing, one may rapidly conclude that the non-spinning or partially-spinning configurations have little to recommend them. Further, the difficulties encountered all tend to push towards examination of the fully-spinning SSUS mated with the satellite which is in turn despun after injection.

The maximum centrifugal acceleration for the EO-09A satellite when spinning at 30 rpm is approximately 2.3 g's. This acceleration requirement would not appear to present a severe problem if imposed at the inception of a satellite design cycle. If, however, one imposes the requirement on an already-designed spacecraft, the required redesign might conceivably be extensive.

Table 2-37. Steady-State Angular Velocity Errors for Rotating Platform with Momentum Wheel (Apogee Only)

4a. Beginning of Burn	$l_P = (1.14 - .11 \Omega) \delta$	$l_P = \text{feet}, \Omega = \text{rad/sec} \quad \delta = \text{rad}$ $\Omega_0 = 42.5 \text{ rpm}$
5a. End of Burn	$l_P = (.036 - .0034 \Omega) \delta$	$\Omega_0 = -305 \text{ rpm}$
6a. Midpoint of Burn	$l_P = (.39 - .037 \Omega) \delta$	$\Omega_0 = 10.1 \text{ rpm}$

Case	Ω_0 (rpm)	δ (deg)	ΔV_e (fps)	$l_P @ \Omega = 0$ (in)
4a	42.5	1	84.6	.24
5a	-305	1	84.6	7.45×10^{-3}
6a	10.1	1	84.6	.082

The equipment and material which would have to be added to the baseline shown in Figure 2-20 in order to adapt the EO-09A satellite for use with an SSUS in a conventional spin/despin design consist of:

- a. Pippier-type horizon sensor looking normal to the spin axis
- b. Pippier-type sun sensor looking normal to the spin axis
- c. Added logic - probably to be accommodated in the baseline satellite computer
- d. Active nutation control system - a single-axis linear accelerometer plus some modest computation which feeds a single thruster and drive amplifier (as shown in Figure 2-24).
- e. Added hydrazine for nutation control, attitude control, and velocity corrections.

The added logic must accommodate the nutation control system, the attitude determination processing (to the degree it is done onboard the spacecraft), and the despin operation after injection. Depending on what spinup option is adopted, onboard logic and processing may also be required for this purpose.

The arguments developed for the completely despun and partially despun versions of the EO-09A spacecraft are general enough that it is not necessary to repeat them in terms of the AS-05A and EO-07A spacecraft. To repeat, the configurations have little to recommend them.

The equipment and material which would have to be added to the baseline shown in Figure 2-21 in order to adapt the AS-05A satellite for use with an SSUS in a conventional spin/despin design consist of:

- a. Pippier-type earth sensor looking normal to the spin axis
- b. Pippier-type sun sensor looking normal to the spin axis
- c. Control system electronics which convert the pippier sensors to a thruster drive amplifier signal
- d. Control system thruster and drive amplifier
- e. Active nutation control system - a single-axis linear accelerometer plus some modest computation (in the control electronics) which feeds a single thruster and drive amplifier (as shown earlier in Figure 2-24).

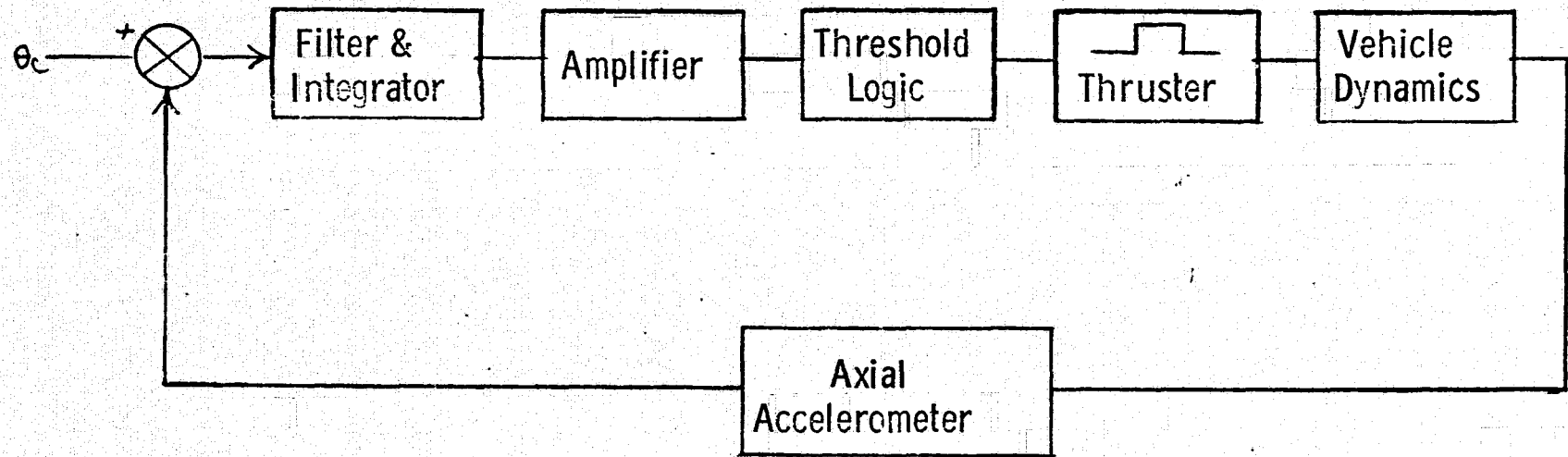

Figure 2-24. Active Nutation Control System Block Diagram

- f. Added hydrazine for nutation control, attitude control, and velocity corrections
- g. Despin control electronics (which may be integral with the control system electronics mentioned above).

The equipment and material which would have to be added to the baseline shown in Figure 2-22 in order to adapt the EO-07A satellite for use with an SSUS consists of the same elements as enumerated above for the AS-05A satellite.

2.6 TELEMETRY, TRACKING, AND COMMAND

2.6.1 Introduction

One of the approaches to cost saving on the SSUS is to minimize the avionics. In the case of telemetry, tracking, and command (TT&C), this is accomplished by increasing the capability on the satellite so that it can provide the TT&C services required by the SSUS.

A study was undertaken to determine the impact on satellite TT&C subsystems of providing the necessary services to the SSUS as part of the complete study.

2.6.2 Basic Satellite TT&C Subsystem Requirements

NASA provided Space Shuttle Payload Data (SSPD) sheets (both Level A and Level B) as design information for Tug-launched versions of the satellites. The requirements and characteristics obtained from these data sheets are shown in Table 2-38.

Briefing charts by Philco on the NASA Synchronous Meteorological Satellite were used as supplementary material for the EO-57A/EO-58A meteorological satellites. The briefing charts were consistent with, and more descriptive than, SSPD data. Accordingly, the information from the briefing charts was used liberally.

For the remaining satellites, it was necessary to make many assumptions. A summary of the resulting requirements/characteristics are shown in Table 2-38.

Table 2-38. Satellite TT&C Characteristics/Requirements (SSPD Data Sheets)

Satellite	Data Rate (bps)		Commands		Attitude Control		Antenna Mission	Type/Gain Housekeeping	Other
	Mission	Hskg.	bps	Number	Type	Offset			
EO-09A	6.8x10 ⁶ /10 ⁷		2000		3 axis				R&R
EO-59A	7x10 ⁶	1024	128		3 axis	+7.2°		2 Omnis/-6dB	
EO-62A	7x10 ⁶	1024	128		3 axis	+7.2°		2 Omnis/-6dB	
EO-57A	28x10 ⁶		120		Spin		Electronically despun		
EO-58A	28x10 ⁶		120		Spin		Electronically despun		
EO-07A	1.21x10 ⁶		2000		3 axis				
AS-05A	43,008		128		3 axis				

NOTE: All services S band except:

EO-57A and EO-58A have S band and VHF transponders

Table 2-39. Satellite TT&C Characteristics/Requirements Used in Study

ORIGINAL PAGE IS
OF POOR
QUALITY

Satellite	Data Rate (bps)		Command		Attitude Control		Antenna Type/Gain		Other
	Mission	Hskg.	bps	Number	Type	Offset	Mission	Housekeeping	
EO-09A EO-59A EO-62A	7×10^6	1024	2000	300	3 axis (earth)	$\pm 7.2^\circ$	1 ft.	Omni/6dB	R&R
EO-57A EO-58A	28×10^6	188	120	300	Spin	Negligible	Electronically Despun (UHF S Band)	Omni (VHF)	R&R
EO-07A	1.21×10^6	1000	2000	300	3 axis (earth)	Negligible	2 ft.	Omni	R&R
AS-05A	43,000	1000	128	300	3 axis (Celestial)	Any	Omni	Omni	R&R

2.6.3 Block Diagrams

The basic block diagram used for the TT&C subsystems is shown in Figure 2-25. The digital telemetry unit and the command decoder and distribution unit are not included in EO-09A/EO-059A/EO-62A because interpretation of the SSPD indicated that these functions are performed by a central data processing subsystem. The Philco briefing charts indicate that the mission data from the EO-57A/58A are transmitted to the ground by a communications transponder that performs additional functions. Among the additional functions performed are relay of data between ground stations, relay of interrogation and response signals to and from remote collection platforms, and relay of processed data from ground stations to aircraft. The communications transponder is not considered part of the TT&C subsystem. However, a block diagram taken from the Philco briefing charts is shown in Figure 2-26 for reference.

2.6.4 Link Analyses

The link analyses were performed for satellite support by NASA's Spaceflight Tracking and Data Network (STDN). The Tracking and Data Relay Satellite (TDRS) is primarily of benefit to low altitude satellites. The SSUS will operate up to synchronous altitude. Thus, TDRS support is not considered for SSUS.

The telemetry links were sized using the following equation, in dB

$$ERP = S/N + SL + K + B - G/T + M + OL$$

where:

ERP = Transmitter power + satellite antenna off-axis gain

S/N = Signal-to-noise ratio (assumed to be 10 dB)

SL = Space loss (191.9 dB for 2250 MHz from synchronous altitude to edge of earth)

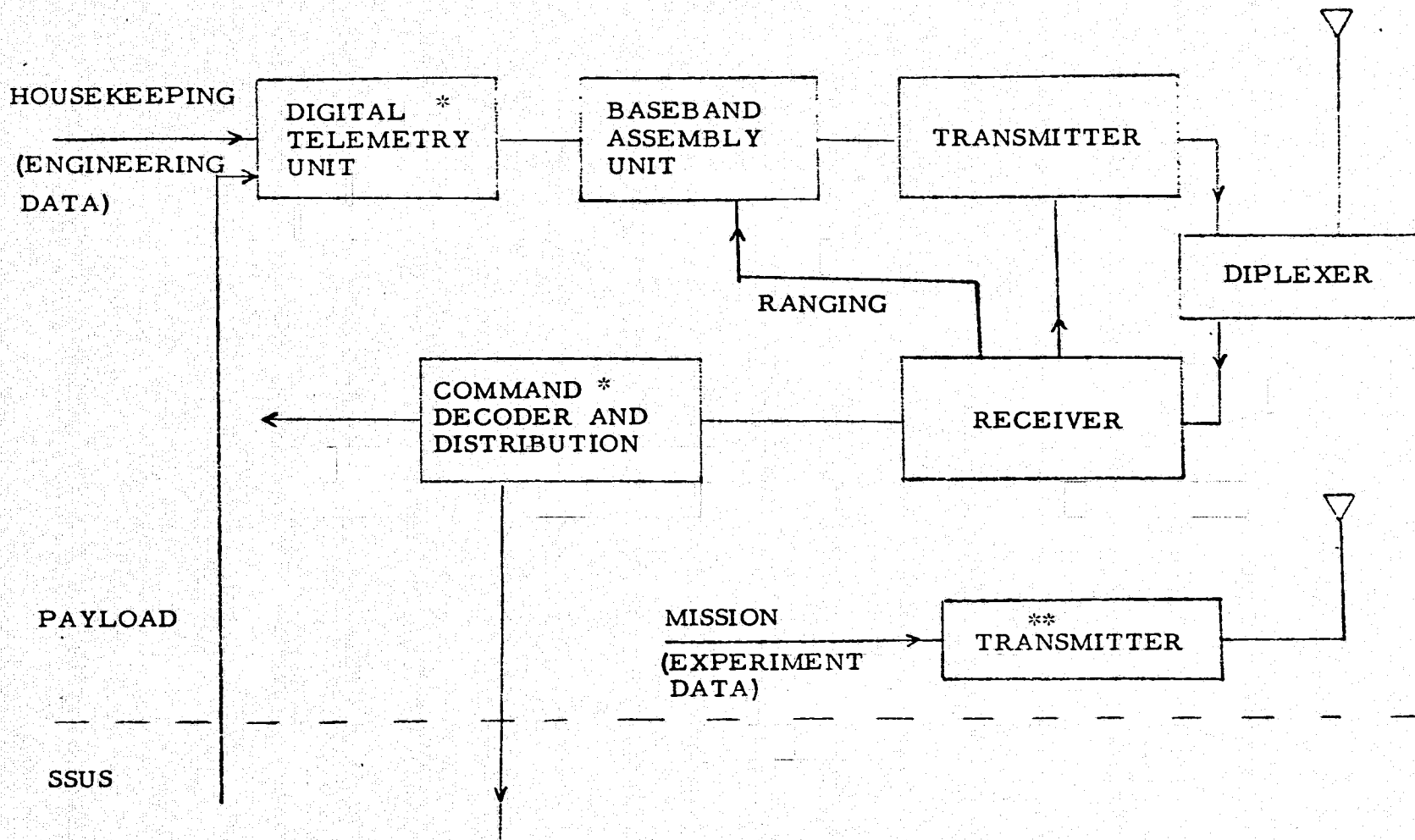

* NOT INCLUDED IN EO-09A, 59A AND 062A

** COMMUNICATIONS TRANSPONDER USED FOR EO-57A AND EO-58A

Figure 2-25. Block Diagram of TT&C Subsystem (Payload Attached to SSU)

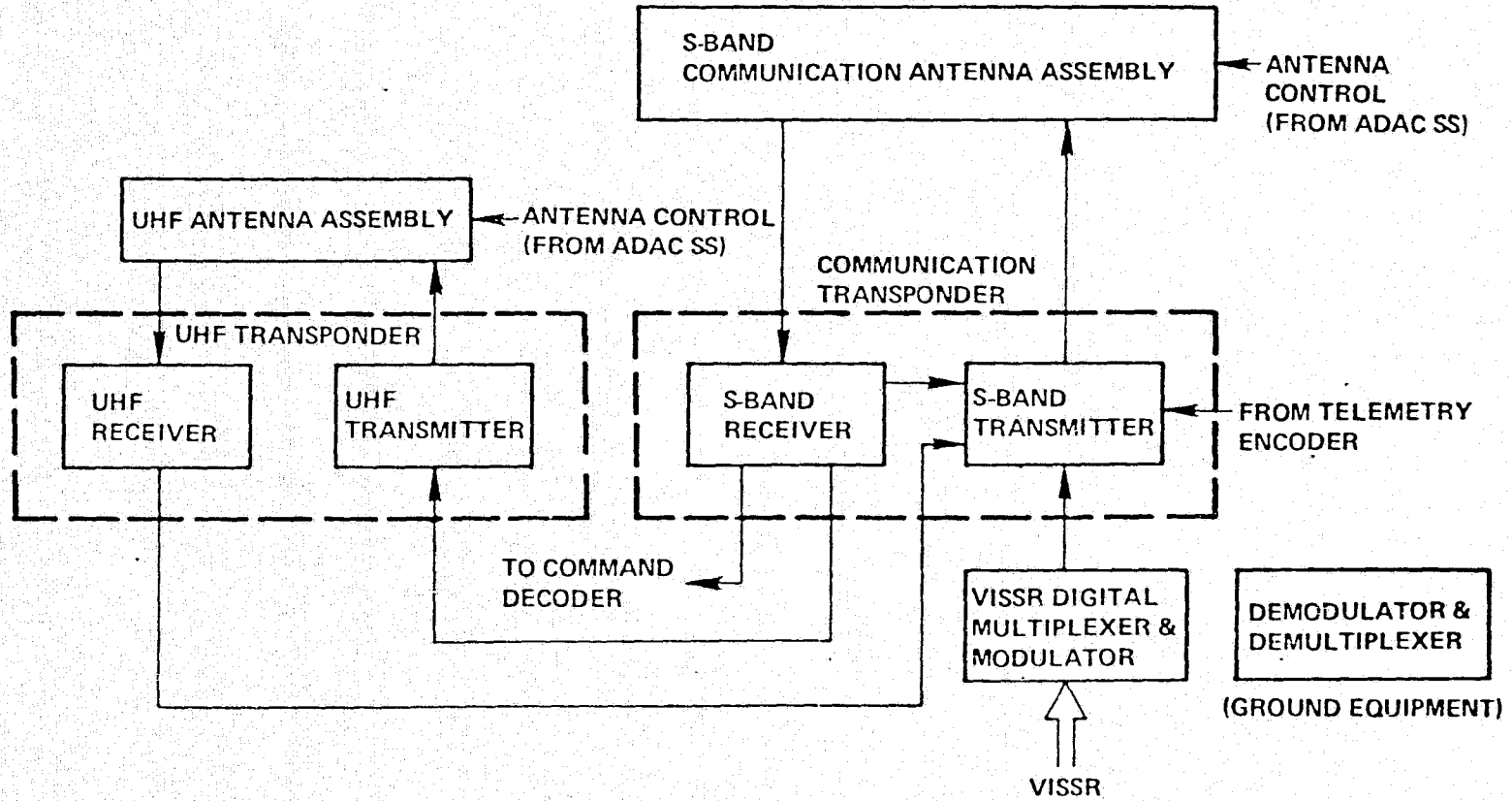

Figure 2-26. SMS Communications Subsystem

K = Boltzman's Constant = -228.6 dBW/HZ/°K

B = Bandwidth (assumed to equal data rate, DR)

G/T = Gain-to-temperature ratio of ground receiving station

M = Margin (assumed to be 6 dB)

O = Other losses made up of:

	<u>Housekeeping Link</u>	<u>Mission Link</u>
Vehicle losses	4 dB	1 dB
Non-ideal hardware losses	4 dB	4 dB
Modulation loss	<u>3 dB</u>	<u>0 dB</u>
	11 dB	5 dB

The ground station is assumed to have an 85-ft antenna with a gain of 52.5 dB and a noise temperature of 200°K. This assumption is based on information in the "Spaceflight Tracking and Data Network Users Guide," dated April 1972, and on informal information which indicates that NASA is phasing out many of the STDN ground stations and that all the stations remaining by about 1980 are expected to have 85-ft antennas. The highest temperature of the 85-ft antenna receiving systems is 200°K. The gain-to-temperature ratio becomes 29.5 dB/°K.

Solving the equation for mission data:

$$\text{ERP} = -45.2 + \text{DR} \quad \text{dBW}$$

For housekeeping data:

$$\text{ERP} = -39.2 + \text{DR} \quad \text{dBW}$$

Link analyses were completed for three satellite configurations. The parameters used and the results obtained are tabulated on the following page.

<u>Mission Data</u>					
Satellite	Data Rate (bps)	ERP (dBW)	Gain (dB)	Power dBW	Power Watts
EO-09A/59A/62A	7×10^6	+23	+10	+13	20
AS-05A	43×10^3	+ 1	- 6	+ 7	5
EO-07A	1.21×10^6	+16	+15	+ 1	1.3
<u>Housekeeping Data</u>					
All Above	1024	- 9	- 6	- 3	0.5

The housekeeping transmitter characteristics for EO-57A/EO-58A were taken from the Philco briefing charts. EO-57A/58A do not have a mission data transmitter because the mission data is transmitted by a communications transponder.

Link analyses for the command transmissions were not performed because a reasonably well designed satellite receiving configuration will close the link from the high power transmitters operating with the high gain antennas of the ground stations.

2.6.5 Additional Requirements for SSUS Compatibility

The additional requirements placed on a satellite TT&C subsystem for SSUS compatibility are presented below.

2.6.5.1 Shuttle Compatibility

The TT&C subsystem must operate at S-Band in order to be compatible with the Orbiter payload integrator. Also, there will probably be a requirement for Orbiter-SSUS communication over a wide range of SSUS attitudes, because of the concern for Orbiter and crew safety while the SSUS is in the vicinity of the Orbiter. Determination of the range of SSUS attitudes for which communications must be maintained with the Orbiter is beyond the scope of this study. However, the approach taken does recognize the need for all-attitude or near-all-attitude coverage.

2.6.5.2 Tracking in the Transfer Orbit

The SSUS concept requires that the satellite TT&C subsystem act as a transponder for tracking during the transfer orbit. The primary impact is on the antenna which must provide appropriate gain in the direction of the ground station. For a single mission, look angles of interest can be determined and appropriate antennas selected. For a generalized study involving a number of missions, the range of look angles of interest is much greater. For this study, it was assumed that the antenna pattern must provide coverage over a wide angle centered about a plane perpendicular to the spin axis.

2.6.5.3 Support of the SSUS

A slight increase is expected in the number of commands and amount of telemetry that the satellite TT&C subsystem must provide for the support of the SSUS, including the commands for PKM firing, AKM firing, and associated events.

Design and production costs of a TT&C subsystem with the slight increase in the number of commands and telemetry data points was considered to be not significantly different than the design and production cost of a TT&C subsystem without this increase. Consequently, the increase in the number of commands and telemetry data points was neglected in this study.

2.6.6 Antenna Concepts

A circular array is normally an attractive candidate for a spinning vehicle that requires broad-beam coverage. Placing the array on the satellite would have a significant impact, especially on satellites that are not cylindrical. Assessment of the acceptability of the impact was not undertaken; however, since the impact might be unacceptable, this approach was ruled out for the study based on the judgment of the spacecraft configuration designer. Placing the array on the AKM, as shown at the top in Figure 2-27, would be more acceptable from the design point of view. However, the

ON ORBIT
ANTENNAS
(STOWED)

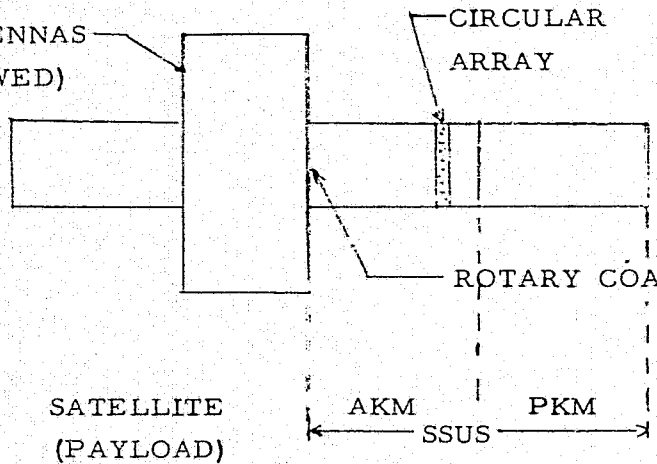

PRCBLEM: COVERAGE MAY NOT
BE ADEQUATE DUE TO
INTERFERENCE

ROTARY COAXIAL CONNECTOR FOR DESPUN PAYLOAD

SATTELLITE
(PAYLOAD)

AKM SSUS PKM

FIGURE 3A

ON ORBIT
ANTENNAS
(STOWED)

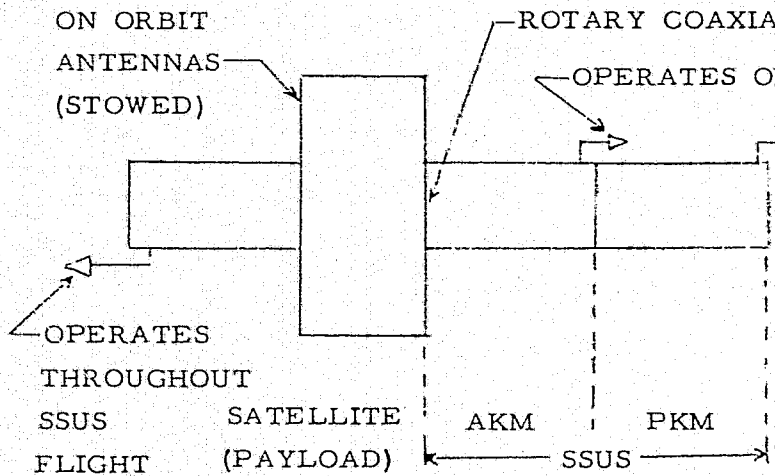

PROBLEM: BOOM/SUPPORT
SELECTED FOR THIS STUDY

RECOMMENDATION/CONCLUSION:
ANTENNA STUDY REQUIRED

Figure 2-27. Illustrative Antenna Concepts

blockage and interference caused by large satellites will result in reduced coverage. The extent to which the coverage is reduced and the acceptability of the reduction require assessment.

A second concept that may be attractive is shown at the bottom in Figure 2-27. It involves the use of two antenna elements, each having approximately hemispherical coverage such as conical spirals. If the two elements are passively coupled for simultaneous operation, regions of interference exist near the plane perpendicular to the line between the antennas. This concept could be implemented so that, in absence of any external signal, the elements are connected passively with the resulting region of interference. Command transmission through the region of interference would be possible, but the command rejection rate would be high. Successful reception of a single command could be used to switch the antenna configuration so that only the appropriate element is energized. There is still a residual problem in that the antenna elements would have to be mounted on some sort of a boom, and the boom, in turn, would have to be supported.

The limited effort of this study was not adequate to provide a supportable recommendation on the antenna configuration. It is concluded that further antenna study would be required as part of a more complete definition of the SSUS concept. For this study, the concept using two conical spiral antennas was selected. The rotary coaxial connector shown in Figure 2-27 would be necessary for the SSUS concept with a despun platform for the satellite.

2.6.7 TT&C Equipment

The TT&C equipment for all satellites studied is tabulated in Tables 2-40 through 2-43.

The basic satellite configurations, before considering the impact of the SSUS, were based on launch by a Tug. No changes are considered necessary for launch by an IUS or an ELV. The transmitter powers generally are generous compared to those determined in the link analysis. An exception is made for EO-09A/59A/62A which is provided with the power determined in the link analysis, because the present state of the art is about 20 Watts.

Table 2-40. EO-09A/59A/62A TT&C Subsystem (Tug, IUS, or Expendable Launch)

Item	Salient Characteristics	Power, Prim (Watts)	Weight (lbs.)
ANTENNA, PARABOLIC	DIA = 0.33 m (1 ft.)	None	2
TRANSMITTER (2)	SBand, 20 Watts	100	6
ANTENNA, TWO CONICAL SPIRALS	Omnidirectional	None	2
TRANSMITTER (2)	S Band, 1 Watt	5	4
RECEIVER (2)	S Band	5 operating 1 standby	4
BASE BAND ASSEMBLY UNIT (2)	1 Subcarrier and Range Turnaround	4	2
MISCELLANEOUS (E. G., DIPLEXER, HYBRID)			4
			24
SSUS LAUNCHED (SPIN/DESPIN OR DESPUN)			
ADD: RF SWITCHES, 1 CONICAL SPIRAL, PROGRAMMER, ETC.			5
			29

NOTE: COMMAND DECODING, COMMAND DISTRIBUTION TM FORMATTING PERFORMED BY DATA PROCESSING SUBSYSTEM

Table 2-41. EO-57A, EO-58A TT&C Subsystem (Tug, IUS, or Expendable Launch)

Item	Salient Characteristics	Power, Prim (Watts)	Weight (lbs.)
Dual Telemetry Unit	188 bps	6	9
VHF Transponder	2 Receivers 2 Transmitters, 8/2 watts	6 24/6	9
Dual Command Unit	128 bps	6	12
VHF Antenna	Array of Monopoles	None	2
Miscellaneous			4
		42/24	36
SSUS LAUNCH			
Dual Telemetry Unit	188 bps	6	9
Dual Command Unit	128 bps	6	12
Receivers (2)	S band	5 operating 1 standby	4
Transmitters (2)	S band, 8 watts	40	4
Antenna, Conical Spirals (2 or 3)	Omnidirectional	None	3
Miscellaneous		2	5
		58	37

ORIGINAL PAGE IS
OF POOR QUALITY

Table 2-42. EO-07A TT&C Subsystem (Tug, IUS, or Expendable Launch)

Item	Salient Characteristics	Prim Power, Each (Watts)	Weight (lbs.)
Antenna, Parabolic	DIA = 2 ft.	None	2
Transmitter (2)	S band, 2 watts	10	4
Antenna, Two Conical Spiral	Omnidirectional	None	2
Transmitter (2)	S band, 1 watt	5	4
Receiver (2)	S band	5 operating 1 standby	4
Baseband Assembly	1 Subcarrier	4	2
Digital Telemetry	1000 bps	6	10
Decoder, Distribution Unit (2)	200 commands	6 operating 1 standby	8
Miscellaneous			4
			<hr/> 40
SSUS LAUNCHED			
Add: RF Switches, Conical Spiral, Programmer, Etc.		2	5
			<hr/> 45

Table 2-43. AS-05A TT&C Subsystem (Tug, IUS, or Expendable Launch)

ORIGINAL PAGE IS
OF POOR QUALITY

Item	Salient Characteristics	Prim Power, Each (Watts)	Weight (lbs.)
Antenna, Two Conical Spirals	Omnidirectional	None	2
Transmitter (2)	S band, 10 Watts	50	6
Antenna, Two Conical Spirals	Omnidirectional	None	2
Transmitter (2)	S band, 1 Watt	5	4
Receiver (2)	S band	5 operating 1 standby	4
Baseband Assembly Unit (2)	1 Subcarrier	4	2
Digital Telemetry Unit (2)	1000 bps	6	10
Decoder, Distribution Unit (2)	200 Commands	6 operating 1 standby	8
Miscellaneous			4
SSUS LAUNCHED			42
Add: RF Switches, Conical Spirals (2), Programmer, Etc.		2	5
			47

2-96

All satellites configured for a SSUS launch reflect the antenna concept described previously. EO-57A/58A was changed from VHF to S-Band for Shuttle compatibility. Other minor changes for SSUS launch include the addition of RF switches for antenna control and a programmer to initiate a sequence such as PKM firing and associated events, following receipt of a single command over the radio link to initiate the sequence.

For SSUS compatibility, the satellite TT&C equipment must operate during the transfer orbit. This places a load on the satellite electrical power subsystem that normally is not included in the sizing of that subsystem. Table 2-44 shows the TT&C equipment that must be powered for various modes of operation during the transfer orbit as an input to the power required from the electrical power subsystem.

2.6.8 Summary and Recommendations

The impact on the TT&C subsystems for operation with a spin-stabilized upper stage was most significant on the antenna, which results primarily from the requirement for tracking during transfer orbit and the expected requirement for near all attitude communication with the Orbiter. It is recommended that an antenna study be performed as part of further development of the SSUS concept.

2.7 SPACECRAFT ELECTRICAL POWER SYSTEMS

Power systems were sized for the spacecraft of this study. The seven spacecraft systems were characterized within four descriptions because of the similarities between the EO-09A, EO-59A, and EO-62A and between the EO-57A and EO-58A satellites. Since the earliest projected launch is 1982, these systems can take advantage of technology advances beyond those included in present-day systems.

2.7.1 EO-09A Satellite

The power required by the EO-09A spacecraft is shown in Table 2-45. It is assumed that the payload will not operate during eclipse. The sunlight equinox operation at the end of life is the controlling condition for array sizing. Battery charging is based on a C/15 rate, where C is

Table 2-44. TT&C Components Powered During Transfer Orbit

<u>COMPONENT</u>	<u>MODE</u>			
	<u>STANDBY</u>	<u>BEACON</u>	<u>TRACKING</u>	<u>TT&C</u>
TRANSMITTER		1 ON	1 ON	1 ON
RECEIVER	2 STANDBY	2 STANDBY	1 ON 1 STANDBY	1 ON 1 STANDBY
BASEBAND ASSEMBLY UNIT			1 ON	1 ON
DECODER	2 STANDBY	2 STANDBY	2 STANDBY	1 ON 1 STANDBY
DIGITAL TELEMETRY UNIT				1 ON

Table 2-45. Power Budget for EO-09A, EO-59A, and EO-62A Spacecraft

	Transfer Orbit, Watts	On Orbit Power, Watts			
		Solstice		Equinox.	
		Peak	Ave.	Sunlight	Eclipse
Attitude Control	2	205	85	85	85
Central Data Processor	45	45	45	45	45
Payload	30	160	160	160	30
Thermal	-	-	-	-	-
T. T. & C	7	115	115	115	115
Contingency	<u>9</u>	<u>53</u>	<u>41</u>	<u>41</u>	<u>28</u>
Subtotal	93	578	446	446	303
Harness & Distribution	2	12	9	9	6
Electrical Power	<u>8</u>	<u>8</u>	<u>8</u>	<u>50</u>	<u>-</u>
Total	103	598	463	505	309

the rated capacity of the battery in ampere hours and the 15 represents the time in hours to deplete the rated capacity. The solar array is then sized on the basis of the projected degradation over the 5-year lifetime which gives a beginning-of-life power at equinox of 643 Watts. With a 3-axis oriented array, and improved solar cells of the Helios type, a solar array area of 7.15 m² (77 ft²) is needed.

The batteries are sized to provide eclipse power with a maximum depth of discharge of 60 percent. Three 8 Ah batteries are used to provide the 309-Watt eclipse power load for the maximum 1.2-hour eclipse. Payload operation is not supported during eclipse periods.

During the transfer orbit, about 103 Watts of power will be needed. With the panels folded in against the spacecraft body and the spacecraft spinning, the array will provide 114 Watts with the sun line 30° off the spin axis. Higher power outputs could be obtained by orienting the spin axis more normal to the sun line.

A summary of the EO-09A spacecraft electrical power system is given in Table 2-46.

2.7.2 EO-59A and EO-62A Satellites

Power systems for these two satellites are the same as for the EO-09A satellite.

2.7.3 AS-05A Satellite

The analysis of the AS-05A satellite was conducted in the same manner as for the EO-09A satellite. The power requirements are based on the overall power level as provided by NASA/MSC. In addition to these power demands, 10 percent contingency allowance, a 2 percent harness and distribution loss, and the power needed for charging the batteries has been added. Electrical power characteristics of the AS-05A satellite are given in Table 2-47. The electrical power system is sized to provide for full payload operation during eclipse periods.

Table 2-46. Electrical Power Subsystem: EO-09A, EO-59A, and EO-62A Satellites

- TYPE: PADDLE-MOUNTED SOLAR CELL ARRAY WITH SECONDARY BATTERIES,
POWER CONTROLS AND DISTRIBUTION HARNESS
- ARRAY:
 - o TWO SINGLE DEGREE OF FREEDOM PADDLES ON COMMON SHAFT PERPENDICULAR TO EQUATORIAL PLANE
 - o 77 FT² OF HELIOS (VIOLET) SOLAR CELLS: 12.7% EFFICIENCY, 8 MILS THICK
 - o POWER DISSIPATION SHUNTS
 - o BATTERY CHARGE ARRAY SECTIONS
- BATTERIES:
 - o 22 Ni Cd CELLS/BATTERY
 - o THREE 8 AH BATTERIES: 60% DOD, 15 WATT HR/LB
 - o CHARGE CONTROLS AND RECONDITIONING

	<u>ELECTRICAL LOAD*, WATTS</u>	<u>ARRAY CAPACITY*, WATTS</u>	
		<u>EOL</u>	<u>BOL</u>
SUNLIGHT	505	505	643
ECLIPSE	309**	---	---
TRANSFER ORBIT	103	---	114 (Sun Line 30° from Spin Axis)

*LOADS AND CAPACITIES CITED FOR EQUINOX (MAXIMUM BATTERY CHARGING)

**TELESCOPE SHUT DOWN

Table 2-47. Electrical Power Subsystem: AS-05A Satellite

- TYPE:** PADDLE-MOUNTED SOLAR CELL ARRAY WITH SECONDARY BATTERIES, POWER CONTROLS AND DISTRIBUTION HARNESS
- ARRAY:**
- o TWO SINGLE DEGREE OF FREEDOM PADDLES ON COMMON SHAFT PERPENDICULAR TO ECLIPTIC PLANE
 - o 59 FT² OF HELIOS (VIOLET) SOLAR CELLS: 12.7% EFFICIENCY, 8 MILS THICK
 - o POWER DISSIPATION SHUNTS
 - o BATTERY CHARGE ARRAY SECTIONS
- BATTERIES:**
- o 22 Ni Cd CELLS/BATTERY
 - o THREE 8 AH BATTERIES: 60% DOD, 15 WATT HR/LB
 - o CHARGE CONTROLS AND RECONDITIONING

	<u>ELECTRICAL LOAD*, WATTS</u>	<u>ARRAY CAPACITY*, WATTS</u>	
		<u>EOL</u>	<u>BOL</u>
SUNLIGHT	387	387	493
ECLIPSE	337	---	---
TRANSFER ORBIT	37 (AVG)	---	88 (Sun Line 30° from Spin Axis)

*LOADS AND CAPACITIES CITED FOR EQUINOX (MAXIMUM BATTERY CHARGING)

2. 7. 4 EO-07A Satellite

The EO-07A satellite is the highest powered satellite of those being studied. The electrical power system has also been sized on the basis of providing for full payload operation during eclipse periods. Characteristics of the power system are given in Table 2-48.

2. 7. 5 EO-57A Satellite

The EO-57A satellite is a spin-stabilized satellite. Full payload operation during eclipse periods is provided. Characteristics of the electric power system are given in Table 2-49.

2. 7. 6 EO-58A Satellite

The characteristics of the EO-58A satellite are the same as those of the EO-57A satellite. Characteristics are given in Table 2-49.

2. 7. 7 Electrical Power Technology

Electrical power system design is currently experiencing the greatest performance growth since the beginning of the space era. This makes it difficult to predict power system characteristics for the 1980's. Thus, a system sized on the basis of today's standards might be overly conservative if the projected gains in performance are realized. For example, qualified solar cells are now available with 25 percent more output than was possible 2 years ago. Likewise, nickel-cadmium batteries are now qualified with one third greater energy density than was available a year ago. Additional gains in the performance of solar cells have been demonstrated, and the new nickel-hydrogen battery could have a substantial impact upon battery weight. At the same time, radioisotope - thermoelectric generators (RTGs) are under development with projected availability in the 1980 time period which could make RTG systems prime power system candidates.

In this study, power system characteristics are based upon proven or qualified 1975 technology. For the 1985 or later applications, an indication is given as to what might be available. System characteristics

Table 2-48. Electrical Power Subsystem: EO-07A Satellite

- TYPE: PADDLE-MOUNTED SOLAR CELL ARRAY WITH SECONDARY BATTERIES, POWER CONTROLS AND DISTRIBUTION HARNESS
- ARRAY:
- o TWO SINGLE DEGREE OF FREEDOM PADDLES ON DRIVE MECHANISMS WITH AXES PERPENDICULAR TO EQUATORIAL PLANE
 - o 81 FT² OF HELIOS (VIOLET) SOLAR CELLS: 12.7% EFFICIENCY, 8 MILS THICK
 - o POWER DISSIPATION SHUNTS
 - o BATTERY CHARGE ARRAY SECTIONS
- BATTERIES:
- o 22 Ni Cd CELLS/BATTERY
 - o THREE 12 AH BATTERIES: 60% DOD, 15 WATT HR/LB
 - o CHARGE CONTROLS AND RECONDITIONING

	<u>ELECTRICAL LOAD*, WATTS</u>	<u>ARRAY CAPACITY*, WATTS</u>	
		<u>EOL</u>	<u>BOL</u>
SUNLIGHT	580	580	740
ECLIPSE	505	---	---
TRANSFER ORBIT	37(AVG)	---	132 (Sun Line 30° from Spin Axis)

*LOADS AND CAPACITIES CITED FOR EQUINOX (MAXIMUM BATTERY CHARGING)

Table 2-49. Electrical Power Subsystem: EO-57A and EO-58A Satellites

- TYPE: ○ BODY MOUNTED SOLAR CELL ARRAY WITH SECONDARY BATTERIES, POWER CONTROLS AND DISTRIBUTION HARNESS
- ARRAY ○ BODY MOUNTED, SPINNING ARRAY WITH SPIN AXIS PERPENDICULAR TO ECLIPTIC PLANE
- 60 SQUARE FEET OF HELIOS (VIOLET) SOLAR CELLS, 12.7% EFFICIENT, 8 MILS THICK
- POWER DISSIPATION SHUNTS
- BATTERY CHARGE ARRAY SECTIONS

BATTERIES

- 22 NiCd CELLS/BATTERY
- THREE 4 AH BATTERIES, 60% DOD, 15 WATT HR/LB
- CHARGE CONTROLS AND RECONDITIONING

	ELECTRICAL LOAD*, WATTS	ARRAY CAPACITY*, WATTS	
		<u>EOL</u>	<u>BOL</u>
SUNLIGHT	183	183	232
ECLIPSE	158	-	-
TRANSFER ORBIT	37 (AUG)	-	116

* LOADS AND CAPACITERS CITED FOR EQUINOX (MAXIMUM BATTERY CHARGING)

expressed in this analysis are thus projected to reflect considerable conservatism.

2.7.7.1 Solar Array System

The characteristics of several recent solar array systems developed for military and commercial synchronous altitude communication spacecraft are given in Table 2-50. Five of the satellites use body-mounted solar arrays, while the sixth has an extended array. Some of these arrays are designed to deliver rated power after exposure to radiation environments more severe than might be encountered with the spacecraft of this study. Also, all of these arrays use the conventional solar cell performance which was available until recently; i. e., 15 mw/cm^2 at 25°C and air mass zero (AMO).

These solar cells are being replaced in many current applications by the "violet" cells which reached qualified status in 1974. The new cells embody improvements such as shallower junction, a P+ backfield, a finer grid structure, and smaller contact surface area and deliver about 18 mw/cm^2 at 25°C and AMO. The relative performance of the violet cells and conventional cells after radiation is shown in Figure 2-28. The new cells deliver about 20 percent more output after radiation. A listing and description of the new cell types is given in Table 2-51.

Solar cell efficiency is not yet approaching its limiting values. Further increases are likely, and, in response to such promise, the Air Force has recently initiated an 18-month program which calls for development of cells capable of 20 mw/cm^2 . Ultimate goal of a planned extension of this program is an increase in solar cell output to 22 mw/cm^2 . If the new program is successful, the new cells would be available by the early 1980's. However, under the ground rules of this study, solar array sizing is based on the best demonstrated solar cell technology or 18 mw/cm^2 .

2.7.7.2 Battery Systems

Battery systems for several recent satellites are described in Table 2-52. The integrating contractors for each of these systems use

Table 2-50. Solar Array Performance for Synchronous Altitude Satellites

Satellite	NATO III	SKYNET II	INTELSAT III	FLTSATCOM	INTELSAT IV	TACSAT I
Contractor	Philco-Ford	Philco-Ford	TRW	TRW	Hughes	Hughes
Life, yr	5	5	5	5	5	5
Stabilization	Spin	Spin	Spin	3-Axis	Spin	Spin
Array Characteristics						
Cell size, mils	2 x 3.15	2 x 2	2 x 2	2 x 4	2 x 2	2 x 2
Cell thickness, mils	12	14	10	8	13	13.5
Cover thickness, mils	12	6	12	6	12	6
No. of cells	20,120	16,410	10,720	22,632	45,012	7236
Array area, ft ²	165	89	468	237	-	34.2
Array weight, lb						
Solar cells, covers etc.	54.86			51	83.6	
Substrate	45.08			105	75.2	
Hardware				24		
Structure				34		
Total			32		158.8	20.8
Array Performance						
BOL AUT EQUINOX	538	258		1653		
SUN SOLSTICE	468	225	161	1510		
BOL AUT EQUINOX	421	196		1257	500	750
SUN SOLSTICE	375	174	131	1161		
Equiv. radiation, 1 Mev/cm ²						
First Launch			1968		1971	1969

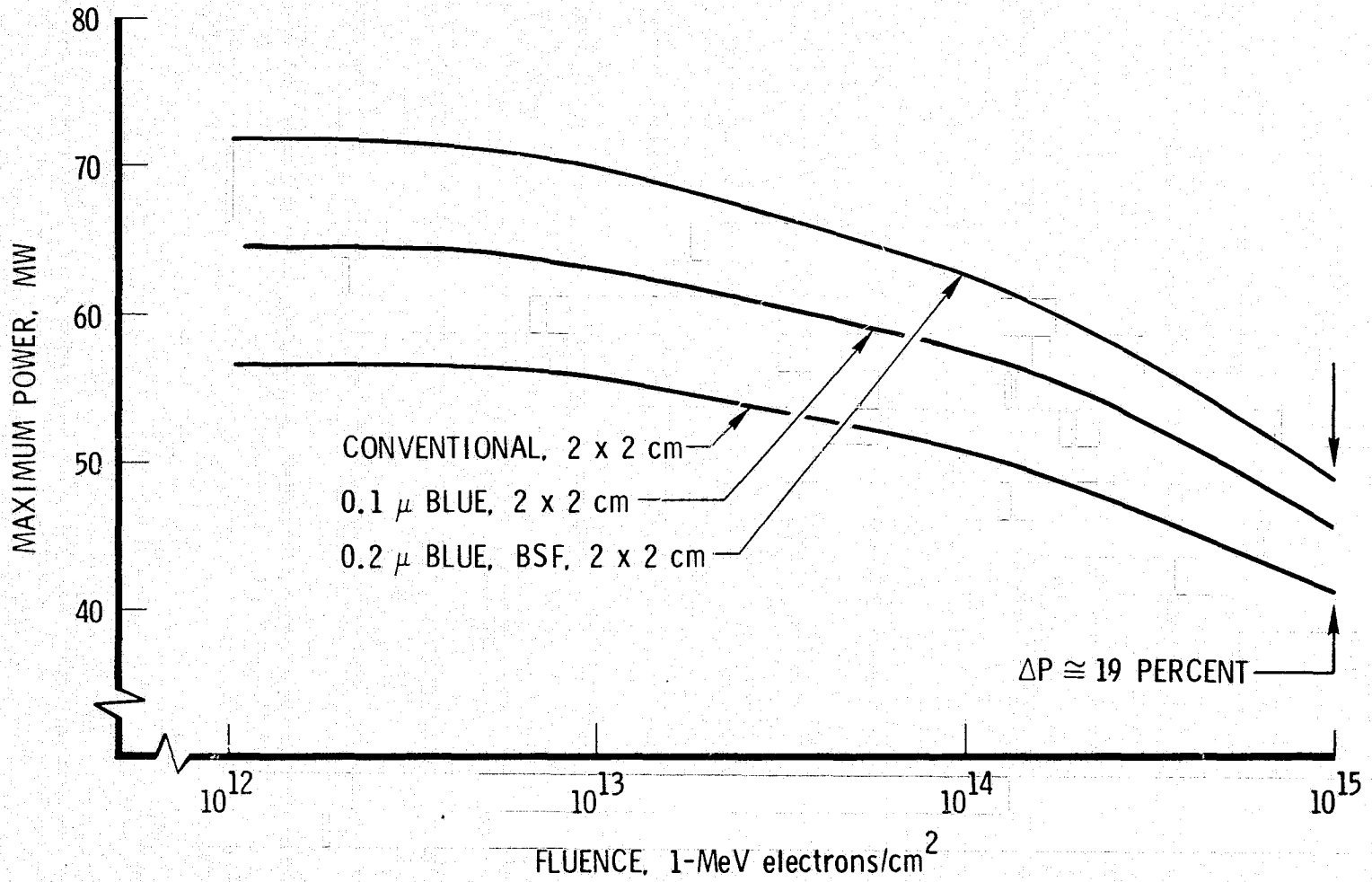

Figure 2-28. Degradation of 10 Ohm-Cm Solar Cells

Table 2-51. Solar Cell Characteristics

	Conventional cell	Hybrid cell	Helios cell	LeRC cell	Hughes K-6, A	Hughes K-6, B		COMSAT violet	COMSAT black
Thickness (μm)	300	300	200	200	300	280		250	?
Base Resistivity (ohm cm)	10	10	10	10	10	20		-2	2
Grids (per cm)	3	9	9	9	8	8		30	?
AR Coating	SiO	Ta ₂ O ₅	Ta ₂ O ₅	Ta ₂ O ₅	Ta ₂ O ₅	Ta ₂ O ₅		Ta ₂ O ₅	Ta ₂ O ₅
Junction Depth (μm)	.30-.35	.15-.20	.18-.23	.15	0.3	0.2		.15	?
Back Field	No	No	Yes	Yes	No	Yes		Yes	Yes
Efficiency (%) AMO, 28° C	10.8	11.7	12.7	12.5	11.6	12.7		14	15.6

Table 2-52. Battery Performance for Synchronous Altitude Satellites

ORIGINAL PAGE IS
OF POOR QUALITY

	SKYNET II	NATO III	INTELSAT III	FLTSATCOM	INTELSAT IV	TACSAT I
Contractor	Philco-Ford	Philco-Ford	TRW	TRW	Hughes	Hughes
Life, yr						3
First Launch						
Battery Characteristics:						
No. of batteries	2.0	3.0	1	3	2.0	3.0
No. of cells/battery	20.0	20.0	20	24	25.0	28.0
Cell capacity, Ah	12.0	20.0	10	24	15.0	6.0
Depth of discharge, %	30.0	30.0	60	72	61.5	55.0
Weight/battery, lb	29.5	26.5	22	65	43.3	21.8
Charge rate			25 W (min)	1.2 amps (min)	1 amp (min)	
Trickle charge rate			0.2 amps	0.24 amps		
Manufacturer	Gulton	E-P	Gulton	GE	GE	Gulton
Size, in.			11.3 x 8.3 x 5.5	16 x 10.6 x 8.2	-	

2-110

differing battery design philosophy which partly explains the differences. A sharp difference in technology capability is seen between the SKYNET II and Nato III spacecraft.

Since eclipsing represents slightly more than one percent of the total operation and at a time when traffic is normally low, the early experimental systems were configured with only partial eclipse capability to save weight.

Of the recent satellites, NATO III demonstrates a significant growth in nickel-cadmium cell technology. The 20 Watt-hr/lb for its battery cells probably represents an energy density which is close to the ultimate cell capability. Further advances will depend upon use of higher depths of discharge. FLTSATCOM uses a different approach by using cell rather than battery redundancy with two extra cells per battery to provide for possible failures. In this battery, the cells are fully protected during charge and discharge with cell bypass electronics.

By the 1980 time period, it is likely that the nickel-hydrogen battery will be qualified and available for application. Cell performance of 20 Watt-hr/lb and adequate cycle lifetimes for synchronous orbit have been demonstrated. TRW Systems predicts that, in an installed battery system, the nickel-hydrogen battery will have an effective energy density of about 11 Watt-hr/lb. The main problems with the NiH₂ cell are in achieving uniform performance and a battery design compatible with the spacecraft.

2.7.7.3 Power System Control

Each integrating contractor has a favorite method for controlling and configuring the power system, and most of these have been successfully demonstrated in orbit. To fully describe the design options available is beyond the scope of this report. Instead, a system has been selected and designed (shown in Figure 2-29) which can be used for obtaining weight estimates.

The solar array uses a partial shunt system to provide main bus voltage regulation. This system is ordinarily used where there are

2-112

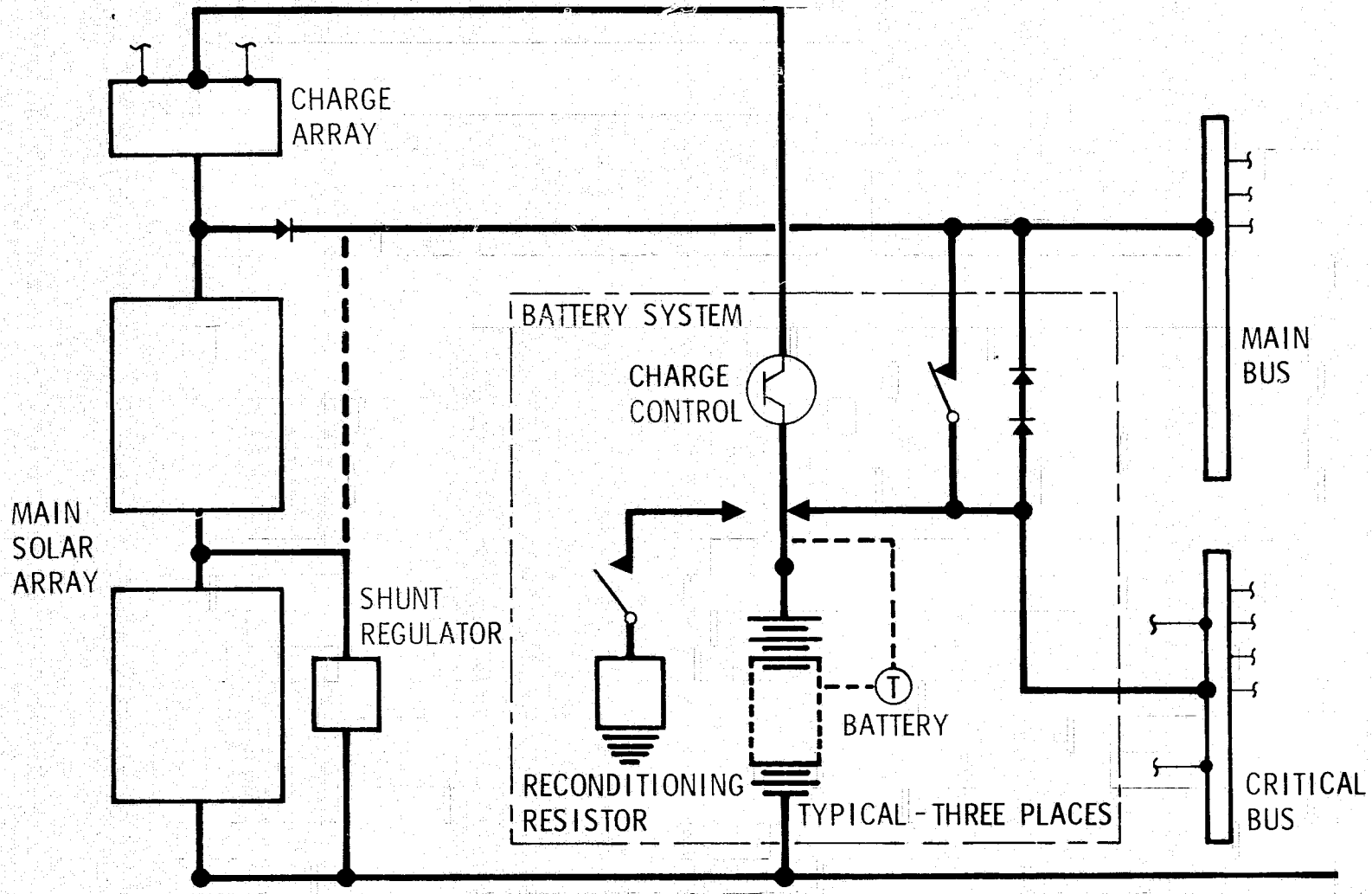

Figure 2-29. SSUS Electrical Power System Typical Schematic

limited power level fluctuations. The shunt dissipators are sized to dissipate the excess power which is available at the beginning of life.

For the battery system, a separate charge array is used to supplement the main array voltage. The use of a separate charge array places a limit on the charge rate to the batteries. The charge control includes an active method of limiting charge. After the battery reaches a designated voltage which is temperature compensated, the battery is reduced to trickle charge.

2.7.7.4 Environment

The solar array will degrade during its lifetime because of the radiation environment. Ultraviolet degradation of about two percent will occur during the first few hours of orbit but will not be a factor thereafter. Another source of rapid degradation occurs when the spacecraft encounters the Van Allen belts during transfer to synchronous altitude. The intensity of this environment is shown in Figure 2-30.

At synchronous altitude, the spacecraft will continuously receive trapped radiation. Intermittently, the spacecraft will receive high-energy proton radiation from solar flares. This latter radiation, while periodic, is unpredictable in intensity or exact time.

At synchronous altitude, cover glasses less than 6 mils thick will protect the solar cells from most of the proton radiation. In order to reduce cost, thicker covers are sometimes used since cover breakage during assembly may be a problem. With the body-mounted arrays, the solar cells receive backside shielding from the spacecraft and the equipment contained in the spacecraft so these arrays will degrade less than an extended array.

Table 2-53 indicates typical levels of radiation for spacecraft in synchronous orbit. Radiation level is expressed in terms of equivalent 1 Mev fluence. The contributions from solar flares represent conditions which might be encountered during the peak years of the solar cycle.

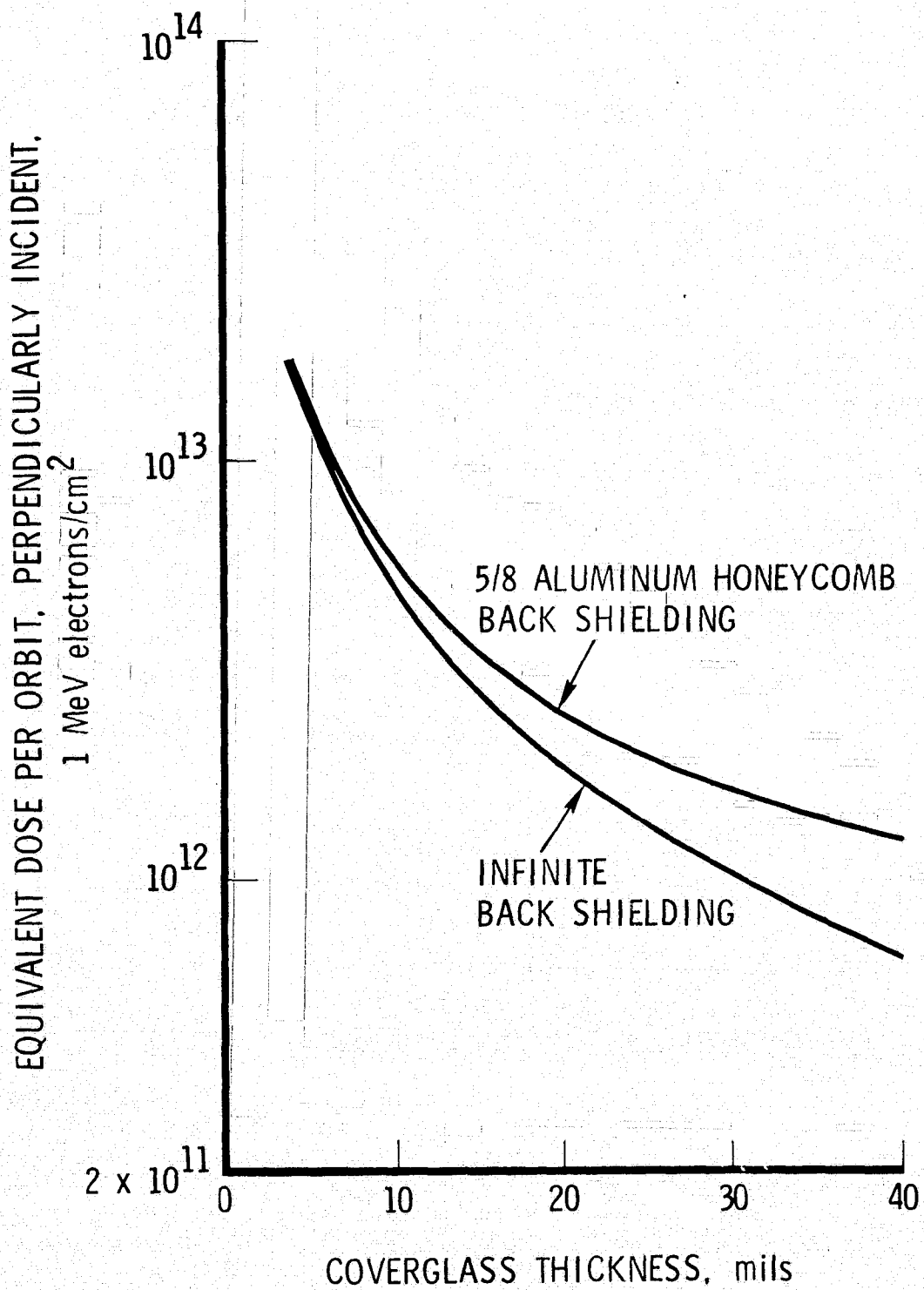

Figure 2-30. 1 MeV Equivalent Radiation Per Revolution of Transfer Orbit (125 nmi to 19,300 nmi)

Table 2-53. Equivalent Radiation Environment of SSUS Spacecraft

Mission	AS-05A	EO-07A	EO-09A	EO-57A	EO-58A	EO-59A	EO-62A
Lifetime, yr	5	5	5	5	5	2	2
Stabilization	3-Axis	3-Axis	3-Axis	Spin	Spin	3-Axis	3-Axis
Cover Slide Thickness	6	6	6	6	6	6	6
Equivalent Radiation 1 MeV electrons							
3-5 Transfer Orbits	0.37 E+14	0.37 E+14	0.37 E+14	0.37 E+14	0.37 E+14	0.37 E+14	0.37 E+14
On Orbit	2.16	2.16	2.16	1.95	1.95	0.86	0.86
Solar Flares	2.11	2.11	2.11	1.90	1.90	2.11	2.11
Total	4.64 E+14	4.64 E+14	4.64 E+14	4.22 E+14	4.22 E+14	3.34	3.34 E+14

2.7.7.5 Radioisotope Thermoelectric Generators

Except for unusual applications, the radioisotope-thermoelectric generator (RTG) has never been a strong candidate for space power. At a power density of one Watt/lb or less, the solar array systems have always proven to be lighter. Cost and availability of radioisotopes has been a problem along with the problem of safety where the basic problem was reentry of the radioisotope.

These problems now seem to be diminishing. The reentry problem has been solved by developing containment systems which can remain intact under any foreseeable event. The heat pipe has reduced system weight by one half. The SNAP 19 which weighs 80 lb could deliver 130 Watts at the end of life. New thermoelectrics of the selenide-type will increase the system efficiency to 10 percent or higher and will allow a reduction in specific weight up to 6 Watts/lb. The increased efficiency will reduce cost as will the application of the Space Tug which will allow recovery of the isotope fuel for reuse.

This study has not examined application of isotope power supplies in any depth, but it does appear that RTGs could be used for some of the missions envisioned for the late 1980's.

2.8 ALTERNATIVES TO TUG-DEPLOYMENT OF SATELLITES

2.8.1 General

Earlier sections of this report discussed the alternatives to Space Tug-deployment of satellites. The principal characteristics of these concepts are summarized in Tables 2-54, 2-55, and 2-56. To determine the effects on the satellites resulting from use of various deployment modes, it is necessary to investigate as a minimum the following differences from Tug-deployed satellites:

- a. Equipment items to accommodate functions added prior to normal orbital operations
- b. Propellants

Table 2-54. Tug-Deployment Concept

- Tug carries one or more payload satellites from Shuttle/Orbiter in 160 nmi orbit (28.5 deg)
- Tug controls all vehicle functions from Orbiter separation through injection (≈ 8 hr)
 - Communications with Orbiter and ground stations
 - Provides up to 600 Watts of electrical power to satellite payloads
- Tug capable of docking with stabilized orbiting satellite
 - On-orbit servicing and retrieval for return to earth by Shuttle/Orbiter
- Geosynchronous payload capability (Tug returns to Orbiter)
 - Delivery only: 3595 kg (7926 lb);
retrieval only: 1540 kg (3396 lb)
- Estimated orbit injection velocity uncertainty: ≤ 25.08 m/sec
(≤ 82.3 ft/sec) (3σ)

Table 2-55. IUS Deployment Concept

- IUS carries one or more payload satellites from Shuttle/Orbiter in 160 nmi orbit (28.5 deg)
- IUS controls all vehicle functions from Orbiter separation through injection (≈ 8 hr)
 - Communications with Orbiter and ground stations
 - No provision for electrical power to satellite payloads
- Satellites assumed neither serviceable nor retrievable
- Geosynchronous payload delivery capability: ≥ 1814 kg (≥ 4000 lb)
- Specified orbit injection velocity uncertainty: ≤ 27.28 m/sec
(≤ 89.5 ft/sec) (3σ)

Table 2-56. SSUS Deployment Concept

- Alternative for 1980's high energy missions, using satellite subsystems and simple stages to minimize cost
- Two solid rocket motor stages in tandem for geosynchronous satellites
- Shuttle/Orbiter checks out, orients, and releases SSUS/Satellite
- Shuttle/Orbiter provides/commands spinup or SSUS/Satellite and commands perigee motor firing
- Orbiter separation through geosynchronous injection
 - Satellite provides communications, commands, attitude control, and satellite power
 - SSUS provides perigee and apogee impulses and ordnance initiator power
- Satellites are neither serviceable nor retrievable
- Geosynchronous payload delivery capability: ≥ 1814 kg (≥ 4000 lb)
- Estimated orbit injection velocity uncertainty: ≤ 118.26 m/sec (≤ 388 ft/sec) (3σ)

- c. Power requirements in the transfer orbit
- d. Spacecraft configuration
- e. Secondary items such as cabling, structure, tankage, pressurants, contingency items, and adapter.

These differences in the satellite have direct impact upon the stages of the space transportation systems. The principal impacts upon these stages exist in the areas of payload weight, interfaces (mechanical, electrical, command, and RF energy), equipment located on the stage, possible power demands, attitude maneuvers (for thermal control, power generation, and pre-injection burn orientation), and limitations on spin rates. In Task I, only the changes in the satellites were evaluated. Task II includes, for each

Note: Some variations in weights quoted for the satellites will be found throughout this report due to the necessity of performing concurrent tasks utilizing available weight estimates prior to the determination of final weight estimates. However, these variations do not materially affect the analyses and results.

satellite studied, more detailed study and provisions for all hardware on the SSUS needed to complement that on the satellite.

2.8.2 Structural Loading Due to Spin

With the SSUS concept, the spin imparts loads not found in the other concepts. The centripetal acceleration, which potentially affects the design of components, mounting provisions, and restraining devices for deployable hardware, is presented in Figure 2-31. It is seen that, at the 30-rpm spin rate selected for transfer of all 3-axis stabilized satellites, the acceleration is less than 2.4 g. This is substantially less than the 3.5 g lateral Shuttle/Orbiter landing load imposed on the satellites and the 4.5 g used for baseline satellite design purposes. Consequently, spin rates up to 42 rpm for the largest satellites considered can be used without apparent design penalties or weight increases.

The EO-57A satellite is assumed to rotate at 100 rpm while on orbit and during SSUS deployment. This is the same spin rate used by the SMS from which the EO-57A satellite is assumed to be derived. This 1.91 m (6.26 ft) diameter satellite experiences a maximum centripetal acceleration of 10.7 g. Design and weight penalties are already included in the SMS design, so no changes need be added for any deployment concept.

2.8.3 Configuration Options

In this study, the principal configurational alternatives to the baseline Tug-deployed satellites were identified and the basic design impacts noted. More complete treatment of the differences in the subsystems is contained in other areas of this report. Comparative summary weight statements and mass properties are presented in this section.

As previously noted, all satellites not deployed by the Space Tug are considered expendable designs for the purposes of this study.

2.8.3.1 EO-09A Satellite

Alternatives to the baseline satellite which were considered were two versions of IUS-deployed satellites, two SSUS-deployed satellites, and a satellite deployed by an expendable launch vehicle.

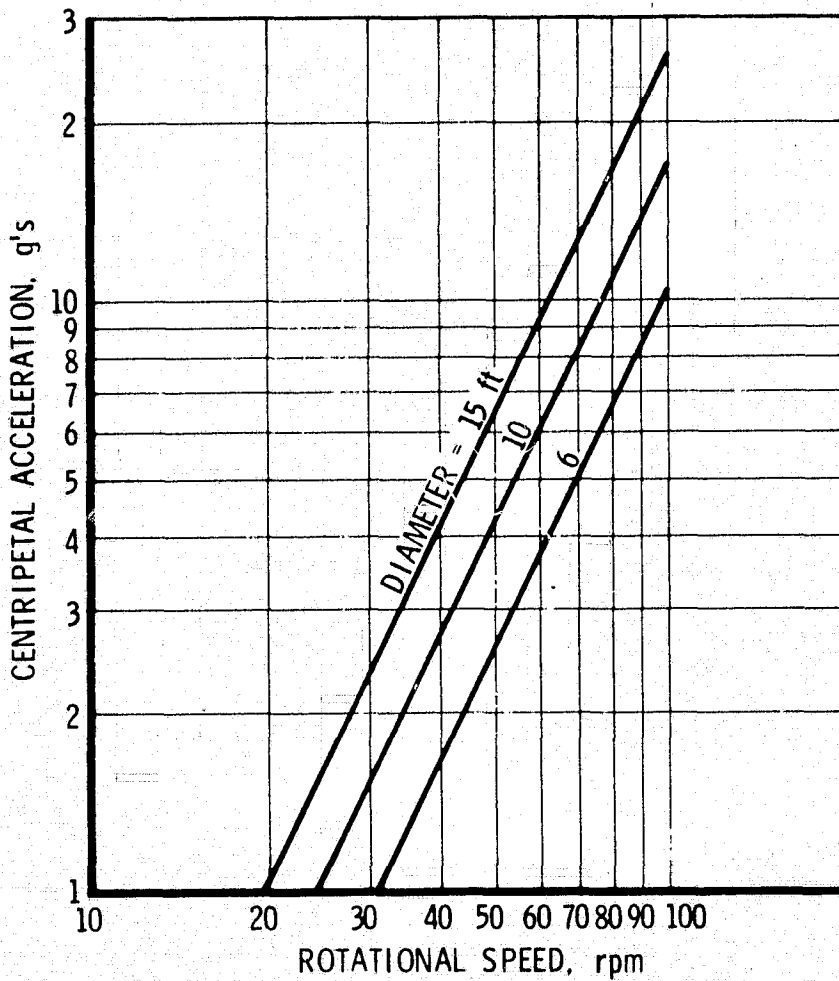

Figure 2-31. Structural Loading Due to Spin

2.8.3.1.1 Tug-Adaptable, Modular, IUS-Deployed Satellite

This design anticipates eventual Tug deployment, space servicing, and retrieval. It has basically the same modular configuration as the baseline in its structure and electrical power distribution. However, it does not have space docking and servicing provisions such as space-removable aft end equipment panels.

2.8.3.1.2 Expendable, Non-Modular, IUS-Deployed Satellite

This design accepts no design complications or weight penalties associated with eventual Tug-deployment. It could employ a different spacecraft configuration but has been assumed to have the same cross section (looking along the longitudinal axis) as the previous IUS design. The spacecraft compartment length is shorter because of improved equipment packing density (20 percent improvement assumed), and the aft closure design is simpler and lighter since it need not accommodate removability.

2.8.3.1.3 SSUS-Deployed Satellite with Spin/Despin Sequence

This satellite has the same basic spacecraft configuration as the IUS design but is altered by provisions for controlling the perigee and apogee burns of the SSUS and the functions in the transfer orbit. The differences in design relative to the Tug-deployed satellite are illustrated in Figure 2-32. The reasons for the differences in the various subsystems are given in other sections of this report.

2.8.3.1.4 SSUS-Deployed Satellite with Satellite Continuously Despun

This design is intended to relieve the satellite of potential stresses resulting from the inherent spin of the SSUS. It has many of the features of the previous SSUS design, but it has extensive differences in the adapter area to permit rotational isolation and to withstand launch loads. There are also considerable differences within the spacecraft to enable control of the vehicle during SSUS motor burns. Satellite differences relative to the baseline are summarized in Figure 2-33, with reasons being given in other sections of this report.

1. Enlarged N_2H_4 Propellant Tanks
2. Non-modular Structure & Reduced Length
3. Pipper-type Earth Horizon Sensor Added
4. Pipper-type Sun Sensor Added
5. Remove Deployable Boom Antennas (Omni) and add a Modified Antenna & Switching Arrangement
6. Docking Provisions Removed
7. Modified Structural Interface Provisions
8. Added Electrical Sensor & Signal Disconnect (Ignition S&A, PKM, AKM and Spin Motors, Separation & RF Signals)
9. Linear Accelerometer (Nutation Sensor) Added

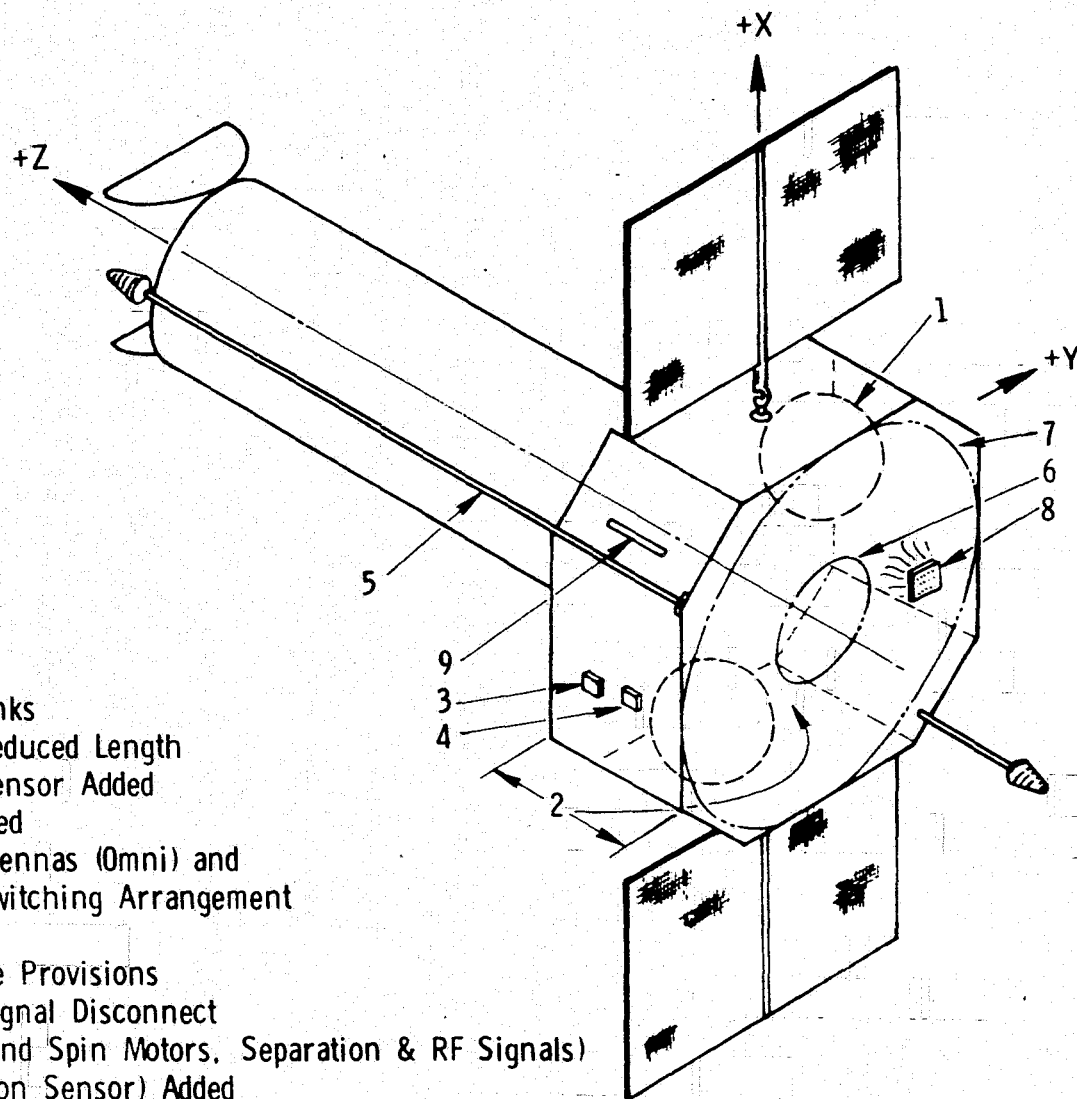

Figure 2-32. Spin/Despin SSUS-Launched EO-09A

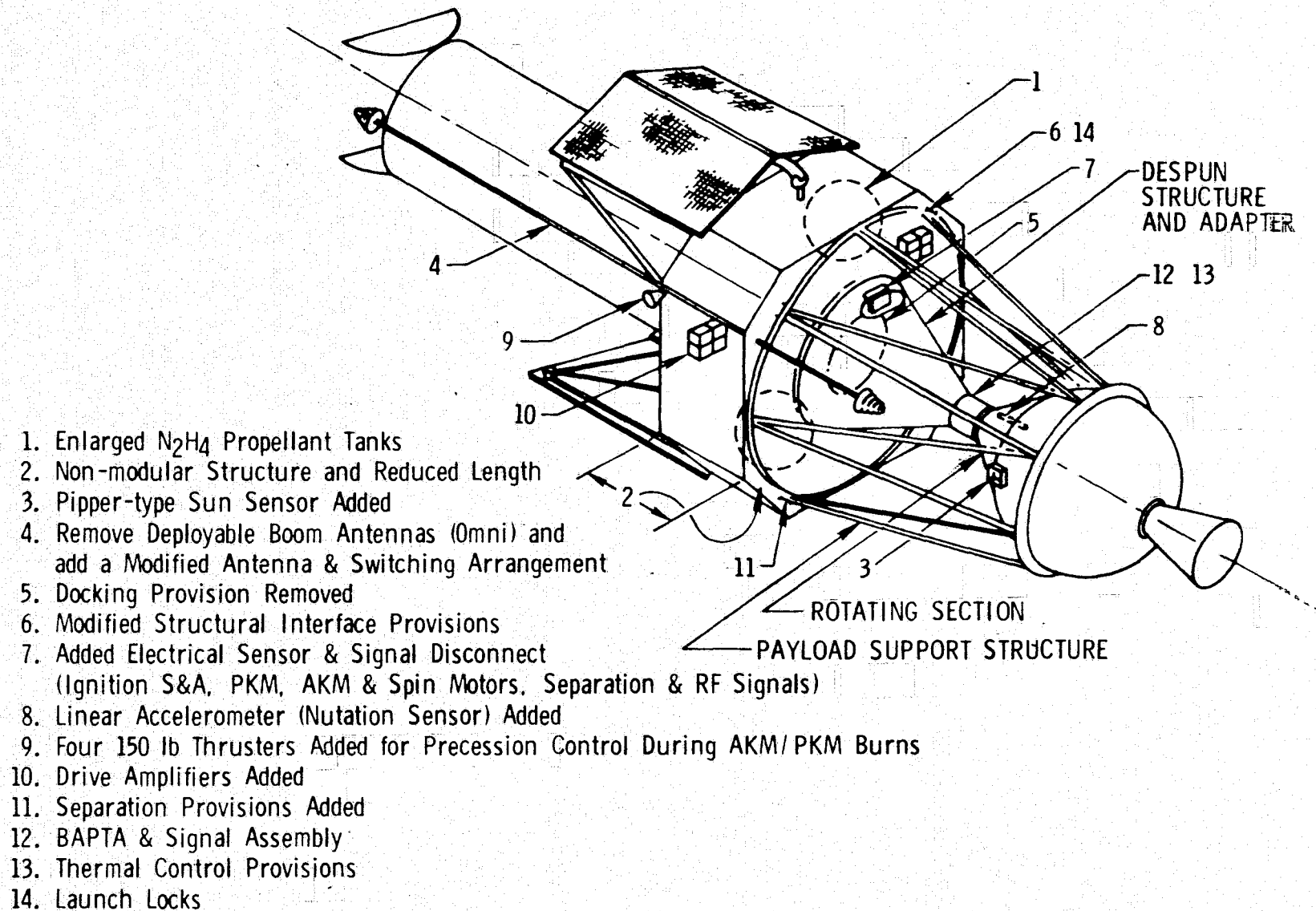

Figure 2-33. SSUS-Launched Despun EO-09A Satellite

2.8.3.1.5 Satellite Deployed by an ELV

This satellite is nominally identical to the second IUS design except for a larger propellant supply needed to correct a larger injection velocity uncertainty. This satellite alternative is discussed in another section of this report.

2.8.3.2 EO-57A Satellite

The alternative deployment vehicles considered for this spin-stabilized satellite were the IUS, the SSUS, and an ELV.

2.8.3.2.1 IUS-Deployed Satellite

This satellite design differs from the Tug-deployed baseline design in the elimination of docking provisions, since retrieval is not called for. The structural weight reduction permits a slight reduction in propellant quantity despite a slightly greater injection velocity uncertainty.

2.8.3.2.2 SSUS-Deployed Satellite

This satellite is given its orbital operations spin rate while attached to the SSUS. It requires no sensor or thruster changes relative to its current operational SMS configuration. However, changes are required for communications compatibility with the Shuttle/Orbiter, control of the SSUS, and the larger injection errors of the SSUS. Differences from the baseline are noted in Figure 2-34.

2.8.3.2.3 Satellite Deployed by an ELV

This is the current method of deploying the existing SMS satellite and is discussed in another section of this report.

2.8.3 EO-07A Satellite

The alternative deployment vehicles considered for this satellite were the IUS, the SSUS, and an ELV.

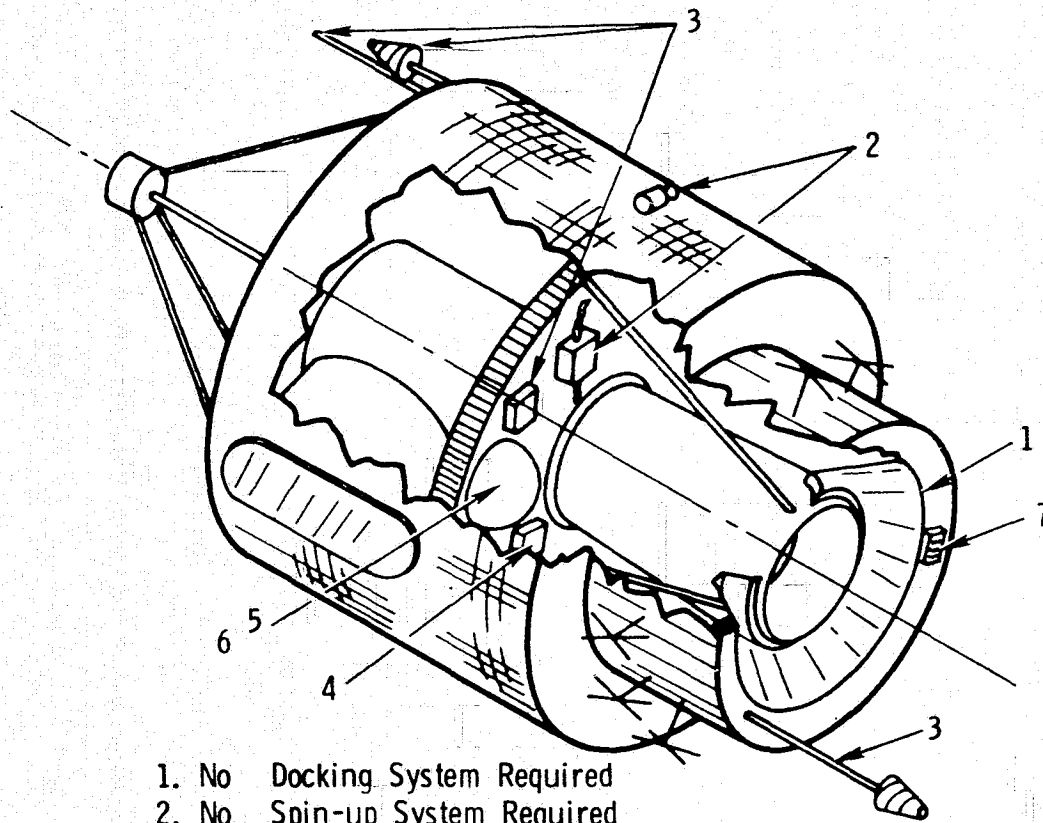

1. No Docking System Required
2. No Spin-up System Required
 - a. Two Small Solid Motors
 - b. Two Ordnance Batteries, Switch & Cabling
3. Remove VHF Transponders (2) & VHF Antenna
Add "S" Band Transponders (2) & "S" Band Antennas (2)
4. Add Programmer, Cabling & RF Switch
5. Enlarge N_2H_4 Propellant Tanks
6. Increase Pressurant Capacity
7. Added Electrical Sensor & Signal Disconnect
(Ignition S&A, PKM, AKM & Spin Motors, Separation & RF Signals)

Figure 2-34. SSUS-Launched EO-57A Satellite

2.8.3.3.1 IUS-Deployed Satellite

Since the baseline Tug-deployed satellite is neither serviceable nor retrievable, deployment by the IUS introduces virtually no changes. Several pounds of additional propellant are required to allow for the slight increase in injection velocity uncertainty.

2.8.3.3.2 SSUS-Deployed Satellite

This satellite employs the spin/despin sequence because of the results of the EO-09A satellite study where the despun payload concept was found undesirable. The satellite could have the same basic cross section as the IUS-deployed satellite, but it might be longer to handle more equipment and propellants associated with control of the perigee and apogee burns of the SSUS and the functions in the transfer orbit. The reasons for the differences in the various subsystems are given in other sections of this report.

2.8.3.3.3 Satellite Deployed by an ELV

This satellite is nominally identical to the baseline and IUS-deployed design, but it requires a larger propellant supply to correct for a larger injection velocity uncertainty. This satellite alternative is discussed in another section of this report.

2.8.3.4 AS-05A Satellite

The remarks made for the EO-07A satellite are applicable to this satellite as well.

2.8.4 Propulsion and Reaction Control Subsystem

For all deployment alternatives to the Space Tug, provisions for additional thrusters and propellant (N_2H_4) capacity are integrated into the satellite. For the spin-stabilized EO-57A satellite, it is assumed that solid propellant spinup rockets are employed on the satellite for use after it is injected by either the Tug or the IUS. Spinup of SSUS stages is presumed

to be accomplished either while attached to the Orbiter or subsequently by means of spin rockets mounted on the SSUS.

The IUS introduces into each satellite design two changes in propellant requirements relative to the Tug-deployed baseline: 1) a small increase in propellant weight due to a seven ft/sec estimated increase in injection velocity uncertainty and 2) a typical reduction in propellant quantity for orbit and attitude maintenance and maneuvering caused by the generally lower weight of an expendable satellite.

The SSUS introduces changes in propellant capacity and thruster requirements. Propellant, tankage, and pressurant changes are introduced by:

- a. An estimated 306-ft/sec increase in injection velocity uncertainty
- b. Despin requirements for three-axis stabilized satellites
- c. Precession maneuvers before perigee and apogee motor firings
- d. Active nutation control in the transfer orbit
- e. Precession control during motor firings for despun payloads
- f. Satellite weight changes which affect orbit and attitude maintenance and maneuver propellant requirements

Thruster changes include

- a. Use of thrusters with short response times to accommodate pulsing operation while the vehicle is spinning
- b. Increased thrust to accommodate precession requirements
- c. Addition of high-level thrusters to prevent precession during motor firings on vehicles having despun payloads.

Catalytic decomposition hydrazine thrusters were assumed to provide a propellant specific impulse of 190 sec while pulsing and 200 sec when operating steady-state such as for momentum wheel unloading and injection error correction.

Expendable launch vehicles would be expected to introduce subsystem changes relative to the baseline in the area of propellants

required for injection velocity error correction. A velocity error increase of 50 or 60 ft/sec will require a corresponding propellant weight increase proportional to the satellite weight.

2.8.5 Electrical Power Subsystem Modifications

Table 2-57 summarizes the power subsystem characteristics for the EO-09A satellite, and it indicates the estimated electrical load in the transfer orbit and the average output power capability of a spinning solar cell array at an adverse sun angle of 30 deg relative to the spin axis. It is seen that there is a significant excess of solar cell array output over load requirement for each satellite, obviating any additional capacity in arrays or batteries or any need to restrict transfer orbit operations when using the SSUS. Most of the 40 hr the vehicle may spend in the transfer orbit could be spent oriented with the spin axis normal to the sun's rays for the purposes of power production and thermal control. Additional power is available from the secondary batteries which presumably would be fully charged before launch in the Shuttle. This source could satisfy any needs for satellite power during the nominal 8-hr deployment by the IUS or comparable periods on ELVs.

Power for operation of SSUS ordnance devices is assumed to be provided by primary batteries mounted on each of the SSUS stages. This should minimize electrical line losses and maximize overall vehicle performance of the SSUS stages. The batteries with their arming devices, switches, and distribution harness are used to fire the initiators for solid propellant spin rockets, apogee and perigee motors, and stage separation devices.

There is expected to be an increase in the weight of umbilical disconnects for satellites deployed by the SSUS because of the expected need to check out all SSUS functions through the satellite. This requires a complex electrical interface between the satellite and the Orbiter and a connector between the satellite and the SSUS for commands and status indication.

Table 2-57. EO-09A Satellite Modifications: Equipment and Power (Watt) Requirements in Transfer Orbit and During Injection

	IUS	SSUS	
		Spin/ Despin	Despun
Mission Equipment			
Data collection system electronics	30	30	30
Central Data Processor	0	45	45
Guidance, Navigation, and Stabilization			
Earth sensor (pipper type)	0	0.1	0
Sun sensor	0	0.1 (Pipper)	0 (Aspect)
Nutation-sensing accelerometer	0	0.2	0
Rate gyro (spinup and spindown)	0	10	0
Valve drive amplifiers for 5-lb thrusters (low duty cycle)	0	0	0
Valve drive amplifiers for 150-lb thrusters (maximum 4 min operation)	0	0	0
Propulsion and Reaction Control			
Thrusters, valves (low duty cycle, 5-6 w/thruster)	0	0	0
150-lb thrusters (4) (maximum 4 min operation @ 60 W for 2 thrusters)	0	0	0.1
Telemetry, Tracking, and Command (Beacon Mode)			
Transmitter	0	5	5
Receivers and decoders (2 each, standby mode)	0	2	2
Programmer and rf switch (low duty cycle)	0	2	2
Adapter (Satellite to Upper Stage)			
Bearing and power transfer assembly	0	0	11
Earth sensor (pipper type)	0	0	0.1
Nutation-sensing accelerometer	0	0	0.2
Electrical Power			
Distribution	0	4	4
Regulation	0	8	8
Contingency	0	8	9

For the EO-09A satellite, the modular Tug baseline and IUS designs require more complex and heavier power distribution provisions than for nonmodular expendable designs. The latter do not require localized power conditioning provisions, as much harness length, or connector designs requiring rigid support and guided mating.

For the EO-57A satellite deployed by the SSUS, spinup solid rockets are not required, so the associated ordnance batteries, switches, and cables are not required.

2.8.6 Equipment Summary

The results of the studies described in previous sections are summarized herein in the form of changes in satellite subsystem equipment and its weight impacts relative to the Tug-deployed baseline satellites. Tables 2-58, 2-59, 2-60, and 2-61 indicate the satellite changes for each alternative to the baseline EO-09A, EO-57A, EO-07A, and AS-05A satellites, respectively. A contingency allowance equal to 15 percent of the total spacecraft dry weight change was applied for each satellite other than the EO-57A which is basically an existing SMS satellite.

2.8.7 Mass Properties

The results of the study are presented in the form of weight statements for each version of each satellite in Tables 2-62 through 2-65. Center of gravity location estimates and moments of inertia about the principal axes with solar cell arrays folded and deployed are presented in Tables 2-66 through 2-69. Inertial axes are defined in Figures 2-35 through 2-38. These data are used in the sizing of SSUS stages and in the evaluation of the suitability of other deployment vehicles.

2.8.8 Summary of Study Results

Summaries of the results of the Task I study are presented in Table 2-70 for three-axis stabilized satellites and in Table 2-71 for the EO-57A spin-stabilized satellite. The comparisons are made primarily between the SSUS-deployed satellites and their most appropriate competitors,

ORIGINAL PAGE IS
OF POOR QUALITY

Table 2-58. EO-09A Satellite Modifications: Equipment and Weight Changes Relative to Tug-Deployed Satellites

	IUS				SSUS			
	Expendable		Modular		Spin/Despin		Despun	
	kg	lb	kg	lb	kg	lb	kg	lb
Structure								
Reduced basic structure volume	-15	-33	0	0	-15	-33	-15	-33
Lightened aft closure	-56	-123	-34	-75	-56	-123	-56	-123
Elimination of Space repair mechanisms	-36	-80	-36	-80	-36	-80	-36	-80
Elimination of docking provisions	-25	-54	-25	-54	-25	-54	-25	-54
Thermal Control								
Reduced insulation, paint	-0.5	-1	0	0	-0.5	-1	-0.5	-1
Guidance, Navigation, and Stabilization								
Added earth sensor (pipper type)	0	0	0	0	+0.5	+1	0	0
Added sun sensor	0	0	0	0	0	0	0	0
					(0.04 pipper)	(0.1 pipper)	(0.11 aspect)	(0.25 aspect)
Added nutation-sensing accelerometer	0	0	0	0	+0.5	+1	0	0
Added rate gyro	0	0	0	0	+2.3	+5	0	0
Added valve drive amplifiers for 150-lb thrusters	0	0	0	0	0	0	+4	+8
Propulsion and Reaction Control								
Tankage, pressurization, plumbing	-2	-4	-1	-2	+8	+18	+24	+52
Thrusters, valves	0	0	0	0	+0.5	+1	+0.5	+1
Added 150-lb thrusters (4)	0	0	0	0	0	0	+25	+56
Telemetry, Tracking, and Command								
Modified omni antenna and booms	0	0	0	0	0	0	0	0
Added programmer capability	0	0	0	0	+0.5	1	+0.5	1
Added rf switch	0	0	0	0	+1	2	+1	2
Added rf cabling and connectors	0	0	0	0	+1	2	+1	2
Electrical Power								
Reduced distribution and regulation	-61	-135	0	0	-60	-133	-60	-133
Added stage umbilical disconnect	0	0	0	0	+1	+2	+1	+2
Contingency								
Reduction at 15% of spacecraft dry weight	-29	-63	-14	-31	-27	-59	-20	-45
Propellants								
Orbit maintenance and maneuvers	(-13.6)	(-30)	(5.5)	(-12)	(67.2)	(+137)	(179.7)	(+396)
Injection velocity uncertainty	-14.5	-32	-6.4	-14	-10.0	-22	-5.9	-13
Despin	+1.4	+3	+1.4	+3	+63.5	+140	+65.8	+145
Precession maneuver	0	0	0	0	+0.5	+1	0	0
Nutation and precession control	0	0	0	0	+4.1	+9	+1.4	+3
Non-expended	0	0	0	0	+0.9	+2	+108.9	+240
	-0.5	-1	-0.5	-1	+3.2	+7	+9.5	+21
Adapter (Satellite to Upper Stage)								
Modified structure	-12	-27	-6	-13	-8	-17	+45	+100
Added separation provisions	0	0	0	0	0	0	+5	+10
Added bearing and power transfer assembly	0	0	0	0	0	0	+61	+135
Modified electrical harness	0	0	0	0	0	0	+2	+5
Added thermal control	0	0	0	0	0	0	+5	+10
Added launch locks	0	0	0	0	0	0	+2	+5
Added earth sensor (pipper type)	0	0	0	0	0	0	+0.5	+1
Added nutation-sensing accelerometer	0	0	0	0	0	0	+0.5	+1
Payload								
	250	-550	-121	-267	-150	-330	+144	+318

Table 2-59. EO-57A Satellite Modifications: Equipment and Weight Changes Relative to Tug-Deployed Satellites

	IUS		SSUS	
	kg	lb	kg	lb
Structure				
Elimination of docking provisions	-38	-84	-38	-84
Guidance, Navigation, and Stabilization				
Add nutation sensor		0	+1	+2
Propulsion and Reaction Control				
Add tankage, pressurization, plumbing		0	+4	+8
Telemetry, Tracking, and Command				
Remove VHF transponders (2)		0	-4	-9
Remove VHF antenna		0	-1	-2
Add S-Band transponders (2)		0	+4	+8
Add S-Band antenna		0	+1.4	+3
Add programmer capability		0	+0.5	+1
Add rf switch		0	+1	+2
Add rf cabling and connectors		0	+1	+2
Electrical Power				
Remove ordnance batteries (2)		0	-2	-4
Remove ordnance switch and cables		0	-1	-2
Add stage umbilical disconnect		0	+1	+2
Propellants				
Orbit maintenance and maneuvers	-4	-8	-3	-7
Injection velocity uncertainty	-0.5	-1	+14	+31
Precession maneuver		0	+3	+6
Residual	-0.5	-1	+0.5	+1
Pressurant		0	+0.5	+1
Spin Rockets				
Remove rockets (2)		0	-1.4	-3
Adapter	-3	-7	-2	-4
Payload	-46	-101	-22	-48

Table 2-60. EO-07A Satellite Modifications Equipment and Weight Changes Relative to Tug- or IUS-Deployed Satellites

Item	SSUS	
	kg	lb
Structure		
Increase in basic structure	+11	+24
Guidance, Navigation, and Stabilization		
Added earth sensor (pipper type)	+0.5	+1
Added sun sensor (pipper type)	+0.5	+1
Added nutation sensor and electronics	+1.4	+3
Added injection control electronics	+3	+6
Added valve drive amplifier for 5-lb thruster	+0.5	+1
Propulsion and Reaction Control		
Tankage, pressurization, plumbing	+5	+12
Added 5-lb thruster	+0.9	+2
Telemetry, Tracking, and Command		
Added programmer capability	+0.5	+1
Added rf switch	+0.9	+2
Added rf cabling and connectors	+0.9	+2
Electrical Power		
Added stage umbilical disconnect	+0.9	+2
Contingency		
Increase at 15% of spacecraft dry weight	+3.6	+8
Propellants		
Orbit maintenance and maneuvers	+3.6	+8
Injection velocity uncertainty	+40	+87
Despin	+0.5	+1
Precession maneuver	+3	+7
Nutation and precession control	+0.9	+2
Non-expended	+0.5	+1
Adapter	+3.6	+8
Payload	+81.7	+179

Table 2-61. AS-05A Satellite Modifications: Equipment and Weight Changes Relative to Tug-Deployed Satellites

Item	IUS		SSUS	
	kg	lb	kg	lb
Guidance, Navigation, and Stabilization				
Added earth sensor (pipper type)		0	+0.5	+1
Added sun sensor (pipper type)		0	+0.5	+1
Added nutation sensor and electronics		0	+1.4	+3
Added valve drive amplifier for 5-lb thruster		0	+0.5	+1
Added injection control electronics		0	+3	+6
Propulsion and Reaction Control				
Tankage, pressurization, plumbing		0	+3	+6
Added 5-lb thruster		0	+0.9	+2
Telemetry, Tracking, and Command				
Added programmer capability		0	+0.5	+1
Added rf switch		0	+0.9	+2
Added rf cabling and connectors		0	+0.9	+2
Electrical Power				
Added stage umbilical disconnect		0	+0.9	+2
Contingency		0	+1.4	+3
Propellants				
Orbit maintenance and maneuvers		0	+0.5	+1
Injection velocity uncertainty	+0.9	+2	+20	+45
Despin		0	+0.5	+1
Precession Maneuver		0	+1.4	+3
Nutation and precession control		0	+0.5	+1
Non-expended		0	+0.9	+2
Adapter		0	+2	+4
Payload (per satellite)	+0.9	+2	+39	+87

Table 2-62. EO-09A Satellite Summary Weight Statement

Item	Tug Modular		IUS Modular		IUS Expendable		SSUS Spin/ Despin		SSUS Despin Platform	
	kg	lb	kg	lb	kg	lb	kg	lb	kg	lb
Structure	350	772	255	563	219	482	219	482	219	482
Thermal Control	32	70	32	70	31	69	31	69	31	69
Guidance, Navigation, and Stabilization	99	217	99	217	99	217	102	224	102	225
Propulsion and Reaction Control	26	58	25	56	24	54	35	77	76	167
Telemetry, Tracking, and Command	25	55	25	55	25	55	27	60	27	60
Central Data Processor	17	38	17	38	17	38	17	38	17	38
Electrical Power	208	458	208	458	147	323	147	325	147	325
Contingency	113	250	99	219	84	186	87	191	93	205
Mission Equipment	764	1685	764	1685	764	1685	764	1685	764	1685
Satellite Dry Weight	1634	3603	1524	3361	1410	3109	1429	3151	1476	3256
Propellants	126	277	120	265	112	247	188	414	305	673
Satellite Wet Weight	1760	3880	1644	3626	1522	3356	1617	3565	1781	3929
Adapter, Including Despin Platform	88	195	83	182	76	168	81	178	210	462
Payload Weight	1848	4075	1727	3808	1598	3524	1698	3743	1991	4391

2-135

Table 2-63. EO-57A Satellite Summary Weight Statement

Item	Tug		IUS		SSUS	
	kg	lb	kg	lb	kg	lb
Structure	75	166	37	82	37	82
Thermal Control	5	11	5	11	5	11
Guidance, Navigation, and Stabilization	12	26	12	26	13	28
Propulsion and Reaction Control	10	23	10	23	13	28
Telemetry, Tracking, and Command	51	113	51	113	54	118
Electrical Power	53	116	53	116	51	112
Mission Equipment	88	194	88	194	88	194
Satellite Dry Weight	294	649	256	565	260	573
Propellants	36	79	31	69	50	111
Satellite Wet Weight	330	728	288	634	310	684
Adapter	25	55	22	48	23	51
Payload Weight	355	783	309	682	333	735

Table 2-64. EO-07A Satellite Summary Weight Statement

Item	Tug/IUS Expendable		SSUS Spin/Despin	
	kg	lb	kg	lb
Structure	87	192	98	216
Thermal Control	34	75	34	75
Guidance, Navigation, and Stabilization	104	230	110	242
Propulsion and Reaction Control	19	41	25	55
Telemetry, Tracking, and Command	61	135	63	140
Electrical Power	135	297	136	299
Contingency	66	145	69	153
Mission Equipment	308	678	308	678
Satellite Dry Weight	814	1793	843	1858
Propellants	89	197	137	393
Satellite Wet Weight	903	1990	980	2161
Adapter	45	100	49	108
Payload Weight	948	2090	1029	2269

Table 2-65. AS-05A Satellite Summary Weight Statement

Item	Tug/IUS		SSUS	
	kg	lb	kg	lb
Structure	77	170	77	170
Thermal Control	18	40	18	40
Guidance, Navigation, and Stabilization	67	147	72	159
Propulsion and Reaction Control	13	28	16	36
Telemetry, Tracking, and Command	23	51	25	56
Electrical Power	90	199	91	201
Contingency	43	95	45	98
Mission Equipment	105	231	105	231
Satellite Dry Weight	436	961	449	991
Propellants	13	28	37	81
Satellite Wet Weight	449	989	486	1072
Adapter	23	50	25	54
Payload Weight	472	1039	511	1126

Table 2-66. EO-09A Satellite Mass Properties

Item	Satellite Deployment				
	Tug	Modular IUS	Expendable IUS	Spin/Despin SSUS	Despin P/L SSUS
Weight, kg (lb)	1760 (3880)	1645 (3626)	1522 (3356)	1617 (3565)	1782 (3929)
Solar Cell Arrays Folded					
CG Location, cm (in.)	146.1 (57.5)	146.1 (57.5)	146.1 (57.5)	146.1 (57.5)	146.1 (57.5)
Moment of Inertia, kg m ² (slug ft ²)					
I _x	2393 (1765)	2237 (1650)	2061 (1520)	2196 (1620)	2421 (1786)
I _y	5095 (3758)	4759 (3510)	4420 (3260)	4678 (3450)	5157 (3804)
I _z	5284 (3897)	4935 (3640)	4583 (3380)	4854 (3580)	5347 (3944)
Solar Cell Arrays Deployed					
CG Location, cm (in.)	143.3 (56.4)	143.3 (56.4)	143.3 (56.4)	143.3 (56.4)	143.3 (56.4)
Moment of Inertia, kg m ² (slug ft ²)					
I _x	2548 (1879)	2379 (1755)	2210 (1630)	2339 (1725)	2579 (1902)
I _y	5106 (3766)	4772 (3520)	4433 (3270)	4684 (3455)	5168 (3812)
I _z	5449 (4009)	5077 (3745)	4718 (3480)	4989 (3680)	5502 (4058)
Notes:					
1. For approximate mass properties, satellite weight distribution, and shape assumed constant.					
2. Adapters from carrier vehicle to satellite neglected.					
3. CG measured from aft end.					

Table 2-67. EO-57A Satellite Mass Properties

	Tug	IUS	SSUS
Weight, kg (lb)	330 (728)	288 (634)	310 (682)
CG from Aft End, cm (in.)	144.0 (56.7)	144.0 (56.7)	144.0 (56.7)
Moment of Inertia, kg m ² (slug ft ²)			
I _x (Roll)	104 (77)	91 (67)	98 (72)
I _y (Pitch)	103 (76)	89 (66)	96 (71)
I _z (Yaw)	113 (83)	99 (73)	106 (78)
Note: Assumes same shape and weight distribution for all cases.			

Table 2-68. EO-07A Satellite Mass Properties (No Adapter)

Item	Tug	IUS	SSUS
Weight, kg (lb)	903 (1990)	904 (1993)	979 (2159)
Arrays Folded			
CG from Aft End, cm (in.)	17.8 (7.0)	17.8 (7.0)	17.8 (7.0)
Moment of Inertia, kg m ² (slug ft ²)			
I _x (Roll)	1100 (811)	1101 (812)	1167 (861)
I _y (Pitch)	602 (444)	603 (445)	640 (472)
I _z (Yaw)	678 (500)	679 (501)	720 (531)
Arrays Deployed			
CG from Aft End, cm (in.)	13.0 (5.1)	13.0 (5.1)	13.0 (5.1)
Moment of Inertia, kg m ² (slug ft ²)			
I _x (Roll)	1369 (1010)	1370 (1011)	1456 (1073)
I _y (Pitch)	517 (318)	518 (382)	549 (405)
I _z (Yaw)	864 (637)	865 (638)	916 (676)
Note: Assumes same shape and weight distribution in all cases.			

Table 2-69. AS-05A Satellite Mass Properties (No Adapter)

Item	Tug	IUS	SSUS
Weight, kg (lb)	449 (989)	450 (991)	486 (1072)
Arrays Folded			
CG from Aft End, cm (in.)	122 (48)	122 (48)	122 (48)
Moment of Inertia, kg m ² (slug ft ²)			
I _x (Roll)	207 (153)	207 (153)	224 (165)
I _y (Pitch)	309 (228)	309 (228)	332 (245)
I _z (Yaw)	329 (243)	329 (243)	359 (265)
Arrays Deployed			
CG from Aft End, cm (in.)	122 (48)	122 (48)	122 (48)
Moment of Inertia, kg m ² (slug ft ²)			
I _x (Roll)	244 (180)	244 (180)	264 (195)
I _y (Pitch)	306 (226)	306 (226)	332 (245)
I _z (Yaw)	369 (272)	369 (272)	400 (295)
Note: Assumes same shape and weight distribution for all cases.			

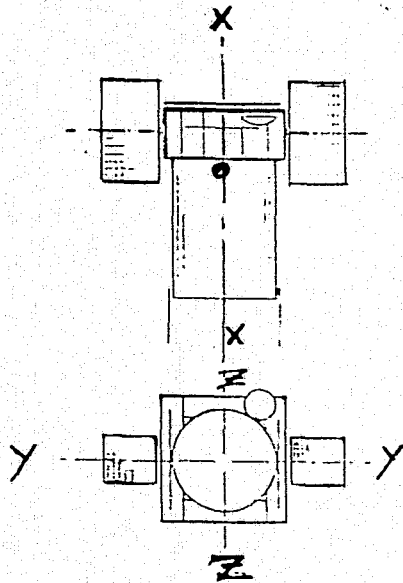

Figure 2-35. EO-09A Inertial Data Axes

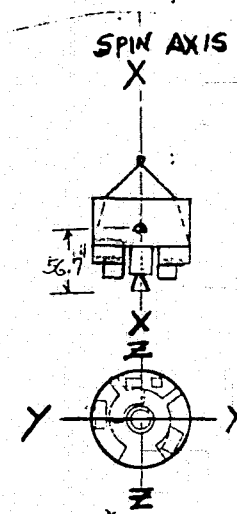

Figure 2-36. EO-57A Inertial Data Axes

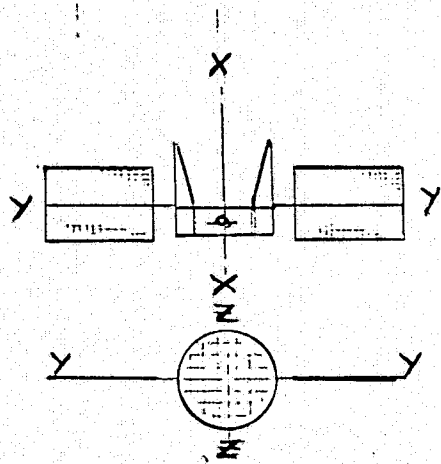

Figure 2-37. EO-07A Inertial Data Axes

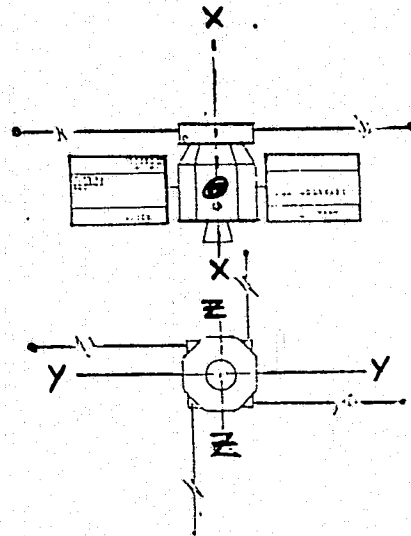

Figure 2-38. AS-05A Inertial Data Axes

Table 2-70. Summary of Study Results, Three-Axis Stabilized Satellites (EO-09A, EO-07A, AS-05A)

- IUS-deployed, expendable satellite designs are simplest, lightest
- SSUS-deployed satellite designs
 - 6.2 to 8.5% heavier than IUS-deployed expendable designs
 - Additional sensors, propulsion hardware and propellants, antenna switching, umbilicals
 - Active nutation control required in transfer orbit
 - No structural penalties at 30-40 rpm spin rates
 - No power subsystem capacity increase required
 - Despun platform design is complex and very heavy
 - Central data processor of EO-09A satellite minimizes attitude control subsystem changes

Table 2-71. Summary of Study Results, Spin-Stabilized Satellite (EO-57A)

- IUS-deployed, expendable satellite design is lightest but requires spinup
- SSUS-deployed satellite design
 - 7.8% heavier than IUS expendable design
 - Additional propulsion hardware and propellants, antenna switching, umbilicals
 - Replacement of VHF equipment with S-Band equipment
 - Active nutation control required in transfer orbit
 - No structural penalties at 100 rpm spin rate
 - No power subsystem capacity increase required

the expendable IUS-deployed satellites. Such comparisons are not obscured by differences in satellite capability associated with ability to be serviced in orbit or retrieved for ground refurbishment.

2.9 COST ESTIMATING PROCEDURES

2.9.1 Introduction

The purpose of this section is to describe the methods of cost analysis employed in Task I of the study. In prior studies, where the incremental cost associated with alternative designs was to be examined, no method of cost analysis was available that could accurately model such effects, because previous models dealt with aggregate subsystems rather than with component costs. Recent improvements in the field of cost-data acquisition have made possible the development for NASA of a Spacecraft Cost/Performance Model that is component oriented.* Advantage has been taken of this model by adapting it for use in the cost analysis portion of Task I. The output of the modified cost model is a set of RDT&E and unit costs for each satellite design; each satellite in turn is the result of design considerations associated with operating the satellite from a Tug, IUS, or SSUS. Costs are given in terms of constant 1975 dollars.

2.9.2 Spacecraft Cost Model (SCM)

For Task I, it was determined that the most accurate and consistent way of measuring the effect on RDT&E and unit cost of alternative spacecraft designs was to apply the basic concepts embodied in the Cost/Performance Model. Conceptually, the model (1) accepts as inputs such design considerations as operating altitude, reliability, type of subsystem, and so forth; (2) it produces a series of spacecraft designs that meet the input requirements; and (3) it provides as output the cost associated with each particular design. However, at the time Task I commenced, the data base upon which the model relies was severely limited and was not attuned

* Systems Cost/Performance Analysis (Study 2.3) Final Report, Volume II, Appendix A: Data Base, The Aerospace Corporation, 27 September 1974.

to spacecraft operations with the Shuttle and Tug launch system. It was concluded that the cost portion of the model could be used but that the engineering design subroutine would be bypassed in favor of a detailed analysis by subsystem specialists. Consequently, changes were made in the computer program that provide for direct inputs to the cost subroutine of engineering data concerning component identities and weight and performance information related to structure, wiring, and other non-component assemblies. The result was a modified cost model computer program called SCM.

2.9.2.1 SCM Input Requirements

In essence, the inputs to SCM represent those that normally would be produced by the engineering model subroutine within the complete model. Inputs can be grouped into three classes — one general, one subsystem oriented, and the third component oriented. The first group covers the following items:

- a. Satellite name
- b. Quantity of qual units (full-flight design but not to be flown)
- c. Quantity of flight units
- d. Year of constant dollars (e. g., 1975 dollars)

The next group covers data for each subsystem; i. e., stability and control, auxiliary propulsion, data processing, communications (TT&C), electrical power, structure, thermal control, and mission equipment:

- a. Type of subsystem configuration
- b. Weight of subsystem (plus dry weight of auxiliary propulsion)
- c. Mission equipment RDT&E and unit cost (if needed — treated as throughput)

The third group includes the following information:

- a. Identifying code number of each component in each subsystem
- b. Quantity of each component required
- c. Thrust of attitude control and translational thrusters

- d. Data processing bit rate for spacecraft housekeeping and rate for mission equipment
- e. Harness weight
- f. Power control weight
- g. Weight of converters
- h. Solar array area (ft²) and weight
- i. Battery capacity (amp-hr) and number of cells per battery

2.9.2 SCM Data Base

The inputs to the model were obtained from subsystem specialists. Components were identified by selecting similar components from the model data base. In cases where no similar items existed, component estimates were made and entered into the SCM data base. Thus, the SCM data base consists of the original Cost/Performance Model data base as augmented by the addition of needed components for Task I. Estimates of cost that are produced with the SCM represent nominal costs that normally could be expected for typical satellite programs. Full development of all components is assumed. Accordingly, no provision was made for using previously developed hardware.

2.9.3 Cost Estimates

Of the seven satellites in the NASA Mission Model that were to be considered, several reflected the same weight and performance data. Accordingly, cost estimates were prepared for only four basic types of satellites. These estimates provided RDT&E and unit cost for alternative launch concepts of the four basic satellites that were representative of the seven programs considered. Cost figures were in constant 1975 dollars — unit cost represented a cumulative average unit cost for the first five vehicles. Unit costs were handled thusly for ease of comparison; however, if quantities to be used for qual or flight were to differ markedly from a total of five satellites, then adjustment of unit cost data should be made.

Table 2-72 is a group of computer printouts of SCM estimates for the various satellite configurations.* A set of three pages for each design is provided. The first page presents subsystem details and total satellite cost; the second and third pages provide information on components included in each subsystem. In addition, the third page also gives cost details for non-component items such as wiring harness, thermal control, and structure.

Estimates for the EO-57A series of satellites are not included in these detail printouts. The satellite was judged to be the same as the small meteorological satellite (SMS), for which actual costs were available, and these costs were used for a baseline EO-57A configuration. Relatively minor changes were made to the baseline; thus, the cost of these changes were most easily estimated by applying percentages to the SMS actual cost.

2.9.3.1 Satellite Cost Data Results and Summaries

The satellite cost data are tabularized in Tables 2-73 through 2-79. These data are extracted from the computer cost estimating runs for each satellite and transportation option except for EO-57A and EO-58A data which are based upon adjusted SMS/GOES actual costs. In general, the actual magnitude for the total program RDT&E and unit costs should be utilized with certain caveats, because these data include a throughput cost estimate for each set of mission equipment, and the major emphasis of the estimating process was on identification of cost differences between options without mission equipment impacts.

The principal goal of the SSUS geosynchronous payload mission development cost estimating process is contained in Table 2-73. These data are the cost differences between expendable satellite designs for IUS deployment and spin/despin SSUS deployment. These data show for the three-axis stabilized satellite designs an increase in both RDT&E and unit payload costs. For the AS-05A and EO-07A designs, these cost

*Table 2-72, which is a lengthy computer run, has been placed at the end of the discussion of Cost Estimates (2.9.3) for the convenience of the reader.

Table 2-73. Task I Payload Cost Estimate Summary (Millions of Dollars)

<u>SATELLITE</u>	<u>TUG</u>		<u>IUS</u>		<u>IUS & ELV</u>		<u>SSUS</u>		<u>SSUS (Despun)</u>	
	<u>RDT&E Unit</u>	<u>Unit</u>	<u>RDT&E Unit</u>	<u>Unit</u>	<u>RDT&E Unit</u>	<u>Unit</u>	<u>RDT&E Unit</u>	<u>Unit</u>	<u>RDT&E Unit</u>	<u>Unit</u>
EO-09A										
EO-59A	129.7	47.0	127.8	46.6	124.8	45.8	127.0	46.6	134.3	49.8
EO-62A										
EO-57A	27.9	9.68	N/A		26.7	9.56	26.9	9.63	N/A	
EO-58A										
EO-07A	116.9	44.8	N/A		116.9	44.8	122.5	46.3	N/A	
AS-05A	69.6	22.0	N/A		69.6	22.0	75.1	23.4	N/A	

Table 2-74. Summary Cost Estimate, Δ Costs Major System Changes, IUS Expendable to SSUS Spin/Despin Cases (Millions of 1975 Dollars)

<u>SUBSYSTEM</u>	<u>AS-05A</u>	<u>EO-07A</u>	<u>EO-09A</u>	<u>EO-57A</u>
Structure	0.1/0.02	0.3/0.10	0.1/0.02	N/C
Electrical Power	<0.1/<0.01	0.1/<0.01	<0.1/0.02	-0.1/-0.06
Communications	0.1/0.04	0.1/0.04	0.1/0.04	0.1/0.04
Stability & Control	3.3/0.98	3.2/0.98	1.4/0.54	N/C
Auxiliary Propulsion	0.8/0.24	0.8/0.26	0.2/0.10	0.2/0.09
Total S/C Δ Cost*	5.5/1.40	5.6/1.50	2.2/0.80	0.2/0.07

* Includes GSE, launch support, and fee Δ costs.

Table 2-75. AS-05A System Cost Estimates (Millions of 1975 Dollars)

<u>SUBSYSTEM</u>	<u>TUG/IUS</u> <u>Expendable</u>	<u>Weight</u> <u>lb</u>	<u>SSUS</u> <u>Spin/Despin</u>	<u>Weight</u> <u>lb</u>	<u>REMARKS</u>
Structure	6.5/2.50	170	6.6/2.52	170	Same Weight Structure Carries Higher Total S/C Weight & Meets Multiple Design Criteria
Thermal Control	3.0/0.78		3.0/0.78		
Electrical Power	8.1/3.62	199	8.1/3.62	201	Added Components
Communications	1.7/0.64	51	1.8/0.68	56	Added Components
Data Handling	1.1/0.56		1.1/0.56		
Stability & Control	13.3/5.36	147	16.6/6.34	159	Added Components
Aux. Propulsion	1.4/0.88	28	2.2/1.12	36	Added Components & Propellants (53 lb)
GSE	8.9/-		9.7/-		Function of Total S/C
Launch Support	-/0.56		-/0.60		Function of Total S/C
Total *	69.6/22.0	989	75.1/23.4	1072	

NOTE: \$ x 10⁶

* Total S/C Includes Estimate for Mission Equipment & Fee

Table 2-76. AS-05A Δ Cost Estimates Major System Changes, IUS to SSUS
(Millions of 1975 Dollars)

<u>SUBSYSTEM</u>	Δ \$ <u>RDT&E/Unit</u>	Δ <u>Weight, lb</u>	<u>REMARKS</u>
Structure	0.1/0.02	--	SSUS Heavier Total S/C
Electrical Power	<0.1/ 0.01	2	Add Connector
Communications	0.1/0.04	5	Programmer RF Switch RF Cable - Connector
Stability & Control	3.3/0.98	12	Sun Sensor Earth Sensor Nutation Sensor & Electronics Nutation Valve Driver Control Electronics
Aux. Propulsion	0.8/0.24	8	2-5 lb Thrusters Tankage & Lines Propellants (53 lb)
Total S/C*	5.5/1.40	83	

NOTE: \$ x 10⁶

* Includes GSE, Launch Support, Fee Δ Costs

Table 2-77. EO-07A System Cost Estimates (Millions of 1975 Dollars)

<u>SUBSYSTEM</u>	<u>TUG/IUS</u> Expendable	<u>Weight</u> lbs	<u>SSUS</u> Spin/Despin	<u>Weight</u> lbs	<u>REMARKS</u>
Structure	9.5/3.04	192	9.8/3.14	216	Heavier Structure
Thermal Control	4.1/1.10		4.1/1.10		
Electrical Power	10.2/4.48	297	10.3/4.48	299	Add Connectors
Communications	1.9/0.76	135	2.0/0.80	140	Added Components
Data Handling	21.7/11.64		21.7/11.64		
Stability & Control	16.2/7.32	230	19.4/8.30	242	Added Components
Aux. Propulsion	2.2/1.00	41	3.0/1.26	55	Added Components Propellants (102 lb)
GSE	13.1/-		13.8/-		Function of Total S/C
Launch Support	-/0.86		-/0.88		Function of Total S/C
Total*	116.9/44.8	1990	122.5/46.3	2159	

NOTE: \$ x 10⁶

* Total S/C Includes Estimate for Mission Equipment and Fee

Table 2-78. EO-07A Δ Cost Estimates Major System Changes, IUS to SSUS
(Millions of 1975 Dollars)

<u>SUBSYSTEM</u>	Δ \$ <u>RDT&E/Unit</u>	Δ Weight, lb <u></u>	<u>REMARKS</u>
Structure	0.3/0.10	24	Heavier Structure
Electrical Power	0.1/0.00	2	Add Connector
Communications	0.1/0.04	5	Programmer RF Switch RF Cable & Connector
Stability & Control	3.2/0.98	12	Sun Sensor Earth Sensor Nutation Sensor & Electronics Nutation Valve Driver Control Electronics
Aux. Propulsion	0.8/0.26	14	2-5 lb Thrusters Tankage & Lines Propellants (106 lb)
Total S/C*	5.6/1.50	169	

NOTE: \$ x 10⁶

* Includes GSE, Launch Support, Fee Δ Costs

FOR NEW DESIGN 3-AXIS STABILIZED EXPENDABLE SPACECRAFT

- o Spin/Despin SSUS Option Increases RDT&E/Unit Costs over TUG/IUS/ELV Designs - Stabilization & Control, Auxiliary Propulsion
- o Added Sensors, Systems Functions and Accuracy Corrections
- o RDT&E Increase from \$2 to 6 M, Unit Cost \$0.5 to 1.5 M
- o Increase Influenced by Capability of Basic Spacecraft Equipment

FOR EXISTING SMS (EO-57A/EO-58A) SPIN DESIGN SSUS EFFECTS ARE SMALL

- o RDT&E up \$0.2 M, Unit Cost up \$0.07 M

COST EFFECTS FOR SSUS CAN BE MASKED BY:

- o Costs of Docking/Modular Structure, Service/Retrieval Features - Expendable Satellites have greater package densities/lower weight
- o Spin Comparisons valid between Expendable IUS and Expendable SSUS Designs

DESPUN PLATFORM CONCEPT COSTLY AND TECHNICALLY COMPLEX

increases are about \$5.5 million and \$1.5 million (RDT&E and unit). These satellites were judged to require the most modification for the spin/despin deployment. The EO-09A-type design was judged to have significant equipment capability which could be utilized in the spin/despin and SSUS operations function. Accordingly, the cost impacts for this design appeared to be more modest at \$2.2 million and \$0.8 million RDT&E and unit. The EO-57A satellite, which is designed for 100-rpm, on-orbit, spin-stabilized operation and is an evolution of the spin-stabilized injected SMS/GOES satellites, had the least design adaptation cost. These data show an increase of \$0.2 million and \$0.7 million RDT&E and unit cost which are negligible and primarily associated with added components to utilize TT&C antennas located on the SSUS and to provide added propellant tankage due to higher predicted injection errors. These data indicate that this spin-stabilized satellite is inherently compatible with the SSUS and that the cost impact is negligible.

The three-axis stabilized satellite cost data tables are presented in order of increasing complexity and numbers of design options for each case of explanation. The AS-05A satellite is scheduled for a single launch of two satellites and, by direction of MSFC, was considered as an expendable satellite design only with no consideration of on-orbit servicing or retrieval. The EO-07A satellite likewise consists of a single launch and was by direction expendable. These circumstances resulted in an expendable satellite design which met the criteria for Tug, IUS, and ELV launch with only a change in orbit-error-correction propellant required between options. This results in a single set of cost data for the Tug/IUS/ELV designs.

Different structural design approaches were utilized between the options of AS-05A and EO-07A. The AS-05A structure weight was held constant, but a more sophisticated and test-qualified design was envisioned to accommodate the higher total satellite weight of the SSUS option. The EO-07A structure was treated as having an estimated increase of 11 kg (24 lb) in structure with the same class of design when accommodating the greater overall SSUS satellite option weight. In either approach, similar cost estimate increases were derived.

The other system changes in the satellites were additions of electrical power connectors, communications programmer, RF switches, and cable to function with the SSUS omni-antennas and major additions of controls components consisting of sun sensors, earth sensors, active nutation sensor (linear accelerometer), nutation electronics, a valve driver for the nutation control hydrazine thruster, and added control electronics. Other major system modifications were in the auxiliary propulsion or attitude control system due to the addition of hydrazine thrusters for the active nutation control and increases in the hydrazine tankage and lines to accommodate increased amounts of propellant due to added requirements for nutation, mission precession maneuvers, despin, and a major increase in orbit error correction.

The EO-09A data (EO-59A and EO-62A also) are more complex due to the greater number of design options studied. This payload also was studied in the greatest detail of the three-axis stabilized satellites. The EO-09A baseline Tug design was a modular structure with docking and on-orbit servicing features. This design was modified into a modular IUS design which in subsequent satellites of the EO-09A program could be readily evolved into the serviceable Tug design. A second IUS satellite design for EO-09A was formulated on a fully expendable basis for direct comparison with the SSUS expendable designs to provide the SSUS impact costs without having to factor out modular/serviceable structural aspects. In addition to the SSUS design for a spin/despin deployment, a design featuring a fully despun platform between the EO-09A and the SSUS was investigated. This last option of the fully despun platform proved technically complex and costly. The cost estimates for these several options indicated about a \$3 million RDT&E impact to have the IUS modular design over a IUS expendable satellite design. The Tug modular design with full on-orbit servicing had an RDT&E estimate \$4.9 million higher than the IUS expendable satellite design. The SSUS spin/despun design was estimated to have a \$2.2 million higher RDT&E than the IUS expendable satellite design with the cost impacts in the same subsystem areas enumerated on payloads AS-05A and EO-07A.

The EO-57A and EO-58A cost data considered three options: a non-serviceable but docking (retrieval) Tug design, an IUS expendable design, and a SSUS spin/spin design (which is virtually identical to the ELV or Delta 2914 design). The Tug design considered only the docking structure and did not encompass changes in system safety for retrieval due to limitations in the study. The RDT&E data for all three designs spanned a range of \$1 million based upon use of SMS/GOES costs adjusted. The Tug design is the most costly due to the docking structure, while the IUS expendable design is slightly less costly due to deletion of nutation controls, etc. present in the SSUS spin/spin or Delta 2914 ELV design.

In summary, the SSUS spin/despin design cost impacts for new design, three-axis stabilized satellites appears to be a significant number ranging from \$2 million to \$6 million, depending on basic satellite capability. Multiplied by the many such satellite types in the mission model, this appears to be a very large potential cost. On the other hand, the data for spinning satellites appear to indicate a negligible cost impact, implying what is intuitively true that the SSUS has the most potential application for satellites intended for spin stabilization on orbit.

ORIGINAL PAGE IS
OF POOR QUALITY

Table 2-72.

SPACECRAFT DESIGN AND COST MODEL

SATELLITE SYSTEM EO-09A (TUG)

(MILLIONS OF 1975 DOLLARS)

2-158

SUBSYSTEM COST.	-----RDT+E-----			-----RECURRING-----		
	DESIGN ENGINEERING	TEST AND EVALUATION	TOTAL RDT+E	PRODUCTION ENGINEERING	FAB AND ASSEMBLY	TOTAL RECURRING
STRUCTURE	8.1	3.6	11.6	9.5	10.1	19.6
THERMAL CONTROL	2.9	1.0	4.0	3.5	1.3	5.3
ELECTRICAL POWER	8.9	5.7	14.7	12.4	15.7	28.1
COMMUNICATIONS	.9	.9	1.9	1.6	2.1	3.7
DATA HANDLING	9.7	6.0	15.7	11.4	12.3	24.2
STABILITY AND CONTROL	3.4	2.4	14.8	20.9	19.8	40.7
AUXILIARY PROPULSION	1.4	1.0	2.4	3.3	2.6	6.4
SPACECRAFT MISSION EQUIPMENT	41.4	23.7	65.0 45.2	63.2	65.2	128.3 93.5
SATELLITE QUALIFICATION UNIT(S)			110.2 0.0			221.6
GSE (AGL)			13.9			4.1
LAUNCH SITE SUPPORT						9.3
CONTRACTOR FEE			5.5			
TOTAL SATELLITE			129.7			235.1
AVERAGE UNIT COST						47.0
TOTAL SATELLITE RDT+E AND RECURRING COST						364.3

SATELLITE SYSTEM EO-09A (TUC)

* * * ASSEMBLY DESCRIPTIONS - - DESIGN NUMBER 1 * * * *

STABILIZATION AND CONTROL

IDENT	TYPE	NO.	UNIT WEIGHT	UNIT VOLUME	UNIT POWER	D.E. COST	T.E. COST	VEHICLE PROD. COST	VEHICLE ENG. COST
203	VALVE DRIVER	2	3.0	-0.0	-0.0	138590.0	31425.0	45246.5	77491.1
301	SUN SENSOR W/ ELECT	1	.9	.0	1.0	239110.0	18550.0	61271.3	53337.3
1002	CONTR ELECT	1	30.0	-0.0	-0.0	2011200.0	1326135.0	351917.4	475742.2
1202	HOR SENSOR	2	13.0	-0.0	-0.0	2256943.5	593864.0	927555.8	927568.2
1302	MON WHL	5	17.0	-0.0	-0.0	191582.5	213690.0	26-137.3	161113.1
1703	INT GYRO	5	5.3	-0.0	-0.0	600531.7	512956.0	419254.6	595022.8
2104	STAR SENSOR	6	10.0	-0.0	-0.0	528500.0	817050.0	804050.0	528543.0

AUXILIARY PROPULSION

IDENT	TYPE	NO.	UNIT WEIGHT	UNIT VOLUME	UNIT POWER	D.E. COST	T.E. COST	VEHICLE PROD. COST	VEHICLE ENG. COST
510	MONO THRUST MP-50A	14	1.2	.1	1.0	247189.0	415564.2	155515.3	338651.6

DATA PROCESSING AND INSTRUMENTATION

IDENT	TYPE	NO.	UNIT WEIGHT	UNIT VOLUME	UNIT POWER	D.E. COST	T.E. COST	VEHICLE PROD. COST	VEHICLE ENG. COST
108	GEN. PURP. PROC. AMP	1	20.0	.1	100.0	5405100.0	3532450.0	1503217.5	1278557.1
109	DTU AND CDU	1	18.0	-0.0	-0.0	942750.0	597075.0	345633.2	223004.2

2-159

COMMUNICATIONS

IDENT	TYPE	NO.	UNIT WEIGHT	UNIT VOLUME	UNIT POWER	D.E. COST	T.E. COST	VEHICLE PROD. COST	VEHICLE ENG. COST
101	BAND ASM. UNIT	2	.9	.0	.0	36453.0	11313.0	36197.3	14331.6
202	ANTENNA	1	2.1	2.1	-0.0	130728.0	100560.0	14453.3	30923.2
203	ANTENNA	2	1.0	1.0	-0.0	84210.0	57822.0	27143.0	34612.7
301	TRANSMITTER	2	1.9	.2	10.0	52850.0	62350.0	45246.6	25830.4
306	TRANSMITTER	2	2.8	.0	90.0	138270.0	136270.0	52214.1	56826.9
401	RECEIVER	1	4.0	.4	3.0	95532.0	214947.0	43993.7	22597.8
602	DIPLEXER	2	1.8	.0	1.0	17849.4	12570.0	25338.1	7335.8
603	MISC	1	16.0	-0.0	-0.0	49023.0	50290.0	55301.3	11596.2

ELECTRICAL POWER

IDENT TYPE	NO.	UNIT WEIGHT	UNIT VOLUME	UNIT POWER	D.E. COST	T.L. COST	VEHICLE PROD. COST	VEHICLE ENG. COST
POC BATTERY CELL	3	24.4	.1	-0.1	300537.2	957231.5	472218.8	435302.1

EQUIPMENTS USING COST ESTIMATING RELATIONSHIPS

NAME	WEIGHT	D.E. COST	T.L. COST	VEHICLE PROD. COST	VEHICLE ENG. COST
SOLAR ARRAY	85.0	399534.2	395183.8	738105.9	34508.4
HARNESS	204.0	1104019.3	346428.3	406236.4	261152.0
THERMAL CONTROL	70.0	1920097.3	729215.0	261677.3	454132.2
POWER CONVERTERS	33.0	903557.0	534327.5	245749.9	215159.6
PROPULSION FEED SYS.		668249.8	291364.6	222653.1	158071.2
STRUCTURE	627.0	5290868.2	2492044.7	1464680.9	1251536.1
POWER CONTROL UNITS	77.0	2646517.5	1260483.1	406327.8	626024.3

SPACECRAFT DESIGN AND COST MODEL

SATELLITE SYSTEM EO-03A (MODULAR IUS)

(MILLIONS OF 1975 DOLLARS)

SUBSYSTEM COST	-----RDT+E-----			-----RECURRING-----		TOTAL RECURRING
	DESIGN ENGINEERING	TEST AND EVALUATION	TOTAL RDT+E	PRODUCTION ENGINEERING	FAB AND ASSEMBLY	
STRUCTURE	7.0	3.1	10.1	8.3	9.6	17.9
THERMAL CONTROL	2.9	1.0	4.0	3.5	1.3	5.3
ELECTRICAL POWER	8.9	5.7	14.7	12.4	15.7	28.1
COMMUNICATIONS	9.9	9.9	19.8	1.6	2.1	3.7
DATA HANDLING	9.7	6.0	15.7	11.4	12.3	24.2
STABILITY AND CONTROL	9.4	5.4	14.8	20.9	19.8	40.7
AUXILIARY PROPULSION	1.4	1.0	2.4	3.8	2.6	6.4
SPACECRAFT	40.3	23.2	63.5	61.3	64.7	126.6
MISSION EQUIPMENT			45.2			93.5
SATELLITE			108.7			219.3
QUALIFICATION UNIT(S)			9.0			
GSE (AGE)			13.7			
LAUNCH SITE SUPPORT						4.0
CONTRACTOR FEE			5.4			9.1
TOTAL SATELLITE			127.8			233.2
AVERAGE UNIT COST						46.6
TOTAL SATELLITE RDT+E AND RECURRING COST						351.0

2-161

SATELLITE SYSTEM EO-03A (MODULAR IUS)

*** ASSEMBLY DESCRIPTIONS - - DESIGN NUMBER 1 ***

STABILIZATION AND CONTROL

IDENT	TYPE	NO.	UNIT WEIGHT	UNIT VOLUME	UNIT POWER	D.E. COST	T.E. COST	VEHICLE PROJ. COST	VEHICLE ENG. COST
203	VALVE DRIVER	2	3.0	-0.0	-0.0	186550.0	31425.0	45248.6	77491.1
301	SUN SENSOR W/ELECT	1	.9	.0	1.3	289110.0	186550.0	61271.3	88337.9
1002	CONTR. ELECT	1	30.0	-0.0	-0.0	2011200.0	1326135.0	351917.4	475742.2
1202	HOR. SENSOR	2	13.0	-0.0	-0.0	2256943.5	693364.0	927555.3	927568.2
1302	MOM. WHL	6	17.0	-0.0	-0.0	191562.5	213690.0	254187.3	161113.1
1703	INT. GYRO	6	5.3	-0.0	-0.0	600531.7	512856.0	419254.6	505022.8
2104	STAR. SENSOR	6	10.0	-0.0	-0.0	528500.0	617050.0	804050.0	528543.0

AUXILIARY PROPULSION

IDENT	TYPE	NO.	UNIT WEIGHT	UNIT VOLUME	UNIT POWER	D.E. COST	T.E. COST	VEHICLE PROJ. COST	VEHICLE ENG. COST
816	MONO THRUST MK-50A	14	1.2	.1	1.3	247189.0	415564.2	155515.3	338651.6

DATA PROCESSING AND INSTRUMENTATION

2-162

IDENT	TYPE	NO.	UNIT WEIGHT	UNIT VOLUME	UNIT POWER	D.E. COST	T.E. COST	VEHICLE PROJ. COST	VEHICLE ENG. COST
108	GEN. PURP. PROC. AMPP	1	20.0	.1	100.0	5405100.0	3562430.0	1503217.5	1273557.1
109	DTJ AND CDU	1	18.0	-0.0	-0.0	942750.0	597075.0	345633.2	223004.2

COMMUNICATIONS

IDENT	TYPE	NO.	UNIT WEIGHT	UNIT VOLUME	UNIT POWER	D.E. COST	T.E. COST	VEHICLE PROJ. COST	VEHICLE ENG. COST
101	BANDW. ASM. UNIT	2	.9	.0	.3	36453.0	11313.0	36177.3	14981.6
202	ANTENNA	1	2.1	2.1	-0.0	130728.0	100560.0	14453.8	30423.2
203	ANTENNA	2	1.0	1.0	-0.0	34219.0	57822.0	27148.0	34812.7
301	TRANSMITTER	2	1.3	.2	10.0	62650.0	62650.0	45248.6	25830.4
300	TRANSMITTER	2	2.8	.0	90.0	138270.0	138270.0	62214.1	56826.4
401	RECEIVER	1	4.0	.4	3.0	95532.0	214947.0	43989.7	22597.8
602	DIPLEXER	2	1.8	.0	1.0	17344.4	12570.0	25339.1	7335.8
603	MISC	1	16.0	-0.0	-0.0	49023.0	50230.0	55301.3	11596.2

ELECTRICAL POWER

IDENT TYPE	NO.	UNIT WEIGHT	UNIT VOLUME	UNIT POWER	D.E. COST	T.E. COST	VEHICLE PROJ. COST	VEHICLE ENG. COST
200 BATTERY CELL	3	24.4	.1	-0.9	800537.2	967251.5	472213.5	435302.1

EQUIPMENTS USING COST ESTIMATING RELATIONSHIPS

NAME	HEIGHT	D.E. COST	T.F. COST	VEHICLE PROD. COST	VEHICLE ENG. CO
SOLAR ARRAY	85.0	399534.2	395183.8	738105.9	94508
HARNESS	204.0	1104019.3	346428.3	406286.4	261152
THERMAL CONTROL	78.0	1920097.3	729215.0	261677.3	454192
POWER CONVERTERS	33.0	909587.0	534327.5	246749.9	215159
PROPULSION FEED SYS.		661942.7	284544.2	217519.2	156580
STRUCTURE	522.0	4603023.2	2161319.0	1395754.4	1088828
POWER CONTROL UNITS	77.0	2646517.5	1260483.1	406327.8	626024

2-163

SPACECRAFT DESIGN AND COST MODEL

SATELLITE SYSTEM EO-03A (IUS)

(MILLIONS OF 1975 DOLLARS)

SUBSYSTEM COST.	-----RDT+E-----			-----RECURRING-----		TOTAL RECURRING
	DESIGN ENGINEERING	TEST AND EVALUATION	TOTAL RDT+E	PRODUCTION ENGINEERING	FAB AND ASSEMBLY	
STRUCTURE	0.4	2.4	9.2	7.6	9.4	17.0
THERMAL CONTROL	2.9	1.0	3.9	3.4	1.8	5.2
ELECTRICAL POWER	8.0	5.2	13.2	11.4	14.1	25.5
COMMUNICATIONS	.9	.9	1.9	1.5	2.1	3.7
DATA HANDLING	9.7	6.0	15.7	11.4	12.8	24.2
STABILITY AND CONTROL	9.4	9.4	18.8	20.9	19.9	40.7
AUXILIARY PROPULSION	1.4	1.0	2.4	3.8	2.5	6.3
SPACECRAFT MISSION EQUIPMENT	38.7	22.3	61.0	60.1	62.9	122.9
			45.2			93.5
SATELLITE QUALIFICATION UNIT(S)			106.2			216.2
GSE (AGE)			9.0			
LAUNCH SITE SUPPORT			13.3			3.8
CONTRACTOR FEE			5.2			5.9
TOTAL SATELLITE			124.8			229.1
AVERAGE UNIT COST						45.8
TOTAL SATELLITE RDT+E AND RECURRING COST						353.9

2-164

ORIGINAL PAGE IS
OF POOR QUALITY

SATELLITE SYSTEM EO-09A (IUS)

* * * ASSEMBLY DESCRIPTIONS - - DESIGN NUMBER 1 * * * *

STABILIZATION AND CONTROL

IDENT	TYPE	NO.	UNIT WEIGHT	UNIT VOLUME	UNIT POWER	D.E. COST	T.E. COST	VEHICLE PROD. COST	VEHICLE ENG. COST
203	VALVE DRIVER	2	3.0	-0.0	-0.0	184550.0	31425.0	45245.5	77491.1
301	SUN SENSOR W/ELECT	1	.9	.0	1.0	239110.0	182530.0	61271.3	59337.9
1002	CONTR CLECT	1	30.0	-0.0	-0.0	2011200.0	1325135.0	351917.4	475742.2
1202	HOR SENSOR	2	13.0	-0.0	-0.0	2256943.5	593864.0	927553.4	927568.2
1302	MOM WHL	5	17.0	-0.0	-0.0	131562.5	213690.0	25137.3	151113.1
1703	INT GYRO	3	5.3	-0.0	-0.0	600531.7	312856.0	419254.6	307822.8
2104	STAR SENSOR	5	10.0	-0.0	-0.0	628500.0	817050.0	804050.0	523543.0

AUXILIARY PROPULSION

IDENT	TYPE	NO.	UNIT WEIGHT	UNIT VOLUME	UNIT POWER	D.E. COST	T.E. COST	VEHICLE PROD. COST	VEHICLE ENG. COST
310	MONO THRUST NR-50A	14	1.2	.1	1.0	247139.0	415564.2	155515.3	338551.5

DATA PROCESSING AND INSTRUMENTATION

2-165

IDENT	TYPE	NO.	UNIT WEIGHT	UNIT VOLUME	UNIT POWER	D.E. COST	T.E. COST	VEHICLE PROD. COST	VEHICLE ENG. COST
100	GEN. PURP. PROC. AMPD	1	20.0	.1	100.0	5405100.0	3582450.0	1508217.3	1278557.1
109	JTU AND CDU	1	18.0	-0.0	-0.0	942750.0	597075.0	345633.2	223004.2

COMMUNICATIONS

IDENT	TYPE	NO.	UNIT WEIGHT	UNIT VOLUME	UNIT POWER	D.E. COST	T.E. COST	VEHICLE PROD. COST	VEHICLE ENG. COST
101	BASEBAND ASM. UNIT	2	.9	.0	.0	56453.0	11313.0	36197.3	14991.6
202	ANTENNA	1	2.1	2.1	-0.0	130728.0	100560.0	14451.8	30923.2
203	ANTENNA	2	1.0	1.0	-0.0	84213.0	37822.0	27148.0	34512.7
301	TRANSMITTER	2	1.9	.2	10.0	62850.0	62850.0	45245.5	23830.4
306	TRANSMITTER	2	2.0	.0	90.0	138270.0	138270.0	62214.1	55626.8
401	RECEIVER	1	4.0	.4	3.0	95532.0	214947.0	43983.7	22597.8
602	DIPLEXER	2	1.8	.0	1.0	17843.4	12570.0	25333.1	7335.5
603	MISC	1	16.0	-0.0	-0.0	49023.0	50280.0	55301.3	11596.2

ELECTRICAL POWER

IDENT TYPE	NO.	UNIT WEIGHT	UNIT VOLUME	UNIT POWER	D.E. COST	T.E. COST	VEHICLE PRD. COST	VEHICLE ENG. COST
Z06 BATTERY CELL	5	24.4	.1	-0.1	900537.2	967261.5	472213.8	435302.1

EQUIPMENTS USING COST ESTIMATING RELATIONSHIPS

NAME	HEIGHT	D.E. COST	T.E. COST	VEHICLE PRD. COST	VEHICLE ENG. COST
SOLAR ARRAY	85.0	399534.2	395183.5	736105.9	94508.4
HARNESS	69.0	508540.7	448434.3	181175.9	120305.3
THERMAL CONTROL	69.0	1906332.9	723487.6	259554.9	450936.3
POWER CONVERTERS	33.0	909587.0	534327.5	246749.9	215159.6
PROPULSION FEED. SYS.		652556.4	277644.2	212269.3	154359.9
STRUCTURE	482.0	4192300.4	1965300.8	1366793.9	991673.7
POWER CONTROL UNITS	77.0	2646517.5	1260488.1	406327.8	626024.3

2-166

SPACECRAFT DESIGN AND COST MODEL

SATELLITE SYSTEM EO-07A (TUG OR IUS)

(MILLIONS OF 1975 DOLLARS)

SUBSYSTEM COST.	-----RDT+E-----			-----RECURRING-----		TOTAL RECURRING
	DESIGN ENGINEERING	TEST AND EVALUATION	TOTAL RDT+E	PRODUCTION ENGINEERING	FAB AND ASSEMBLY	
STRUCTURE	6.6	2.9	9.5	7.8	7.4	15.2
2-167 THERMAL CONTROL	3.0	1.1	4.1	3.8	1.9	5.7
ELECTRICAL POWER	5.8	4.5	10.2	9.2	13.1	22.4
COMMUNICATIONS	1.1	.8	1.9	1.3	1.8	3.5
DATA HANDLING	9.6	12.0	21.7	26.3	32.2	58.7
STABILITY AND CONTROL	10.2	6.0	16.2	19.9	17.1	36.0
AUXILIARY PROPULSION	1.2	1.0	2.2	3.1	1.9	5.0
SPACECRAFT MISSION EQUIPMENT	37.5	28.2	65.7	71.2	75.7	146.9
SATELLITE QUALIFICATION UNIT(S)			98.4			209.1
GSE (ASE)			0.0			
LAUNCH SITE SUPPORT			13.1			4.3
CONTRACTOR FEE			5.5			10.6
TOTAL SATELLITE			116.9			224.2
AVERAGE UNIT COST						44.8
TOTAL SATELLITE RDT+E AND RECURRING COST						341.1

SATELLITE SYSTEM EO-19A (SSUS)

* * * ASSEMBLY DESCRIPTIONS - - DESIGN NUMBER 1 * * * *

STABILIZATION AND CONTROL

IDENT	TYPE	NO.	UNIT WEIGHT	UNIT VOLUME	UNIT POWER	D.E. COST	T.E. COST	VEHICLE PROD. COST	VEHICLE ENG. COST
203	VALVE DRIVER	2	3.0	-0.0	-0.0	166550.0	31425.0	45246.0	77491.1
301	SUN SENSOR W/ELECT	1	.9	.0	1.0	289110.0	188550.0	61271.3	48387.9
1003	CONTR ELECT	1	31.0	-0.0	-0.0	2036340.0	1357560.0	364483.9	481583.0
1202	HOR SENSOR	2	13.0	-0.0	-0.0	2256943.5	693864.0	927555.8	927568.2
1302	MOM WHL	6	17.0	-0.0	-0.0	191582.5	213690.0	264187.8	161113.1
1703	INT GYRO	7	5.3	-0.0	-0.0	628107.2	587647.5	477802.8	578969.0
2104	STAR SENSOR	6	10.0	-0.0	-0.0	628500.0	817050.0	804050.0	528543.0
1203	HOR SENSOR	1	1.0	-0.0	-0.0	610902.0	120672.0	72268.8	144506.7

AUXILIARY PROPULSION

IDENT	TYPE	NO.	UNIT WEIGHT	UNIT VOLUME	UNIT POWER	D.E. COST	T.E. COST	VEHICLE PROD. COST	VEHICLE ENG. COST
810	MONO THRUST MR-50A	14	1.2	.1	1.0	247189.0	415564.2	155515.3	338651.6

DATA PROCESSING AND INSTRUMENTATION

IDENT	TYPE	NO.	UNIT WEIGHT	UNIT VOLUME	UNIT POWER	D.E. COST	T.E. COST	VEHICLE PROD. COST	VEHICLE ENG. COST
108	GEN. PWRP. PROC. AMPP	1	20.0	.1	100.0	5405100.0	3582450.0	1508217.5	1278557.1
109	DTU AND CDU	1	18.0	-0.0	-0.0	942750.0	597075.0	345633.2	223004.2

COMMUNICATIONS

IDENT	TYPE	NO.	UNIT WEIGHT	UNIT VOLUME	UNIT POWER	D.E. COST	T.E. COST	VEHICLE PROD. COST	VEHICLE ENG. COST
101	BASEBAND ASM. UNIT	2	.9	.0	.5	36453.0	11313.0	36197.3	14981.6
202	ANTENNA	1	2.1	2.1	-0.0	130728.0	100560.0	14453.8	30923.2
203	ANTENNA	2	1.0	1.0	-0.0	84219.0	57822.0	27148.0	34612.7
301	TRANSMITTER	2	1.9	.2	10.0	62350.0	62850.0	45246.6	25830.4
306	TRANSMITTER	1	2.8	.0	90.0	138270.0	138270.0	62214.1	56826.8
401	RECEIVER	1	4.0	.4	3.0	95532.0	214947.0	43989.7	22597.8
602	DIPLEXER	2	1.8	.0	1.0	17849.4	12570.0	25338.1	7335.8
603	MISC	1	16.0	-0.0	-0.0	49023.0	50289.0	55301.3	11596.2
605	MISC	1	5.0	-0.0	-0.0	31425.0	23883.0	26393.8	7433.5

2-168

ELECTRICAL POWER

IDENT	TYPE	NO.	UNIT WEIGHT	UNIT VOLUME	UNIT POWER	D.E. COST	T.E. COST	VEHICLE PROD. COST	VEHICLE ENG. COST
205	BATTERY CELL	3	24.4	.1	-C.O.	830537.2	967261.5	472213.8	455332.1

EQUIPMENTS USING COST ESTIMATING RELATIONSHIPS

NAME	WEIGHT	D.E. COST	T.E. COST	VEHICLE PROD. COST	VEHICLE ENG. COST
SOLAR ARRAY	85.0	399534.2	395183.8	738105.9	94505.1
HARNESS	73.0	529561.5	463981.2	188944.1	125251.1
THERMAL CONTROL	69.0	1906332.9	723987.6	259554.9	453938.8
POWER CONVERTERS	33.0	909587.0	534327.5	246749.9	215158.8
PROPULSION FEED SYS.		726449.6	346558.6	264381.4	171830.8
STRUCTURE	482.0	4224695.6	1980991.1	1366793.9	999338.8
POWER CONTROL UNITS	77.0	2646517.5	1260488.1	406327.8	626020.8

2-169

SPACECRAFT DESIGN AND COST MODEL

SATELLITE SYSTEM EO-09A (SSUS-DESPIN)

(MILLIONS OF 1975 DOLLARS)

ORIGINAL PAGE IS
OF POOR QUALITY

SUBSYSTEM COST	-----RDT+E-----			-----RECURRING-----		
	DESIGN ENGINEERING	TEST AND EVALUATION	TOTAL RDT+E	PRODUCTION ENGINEERING	FAB AND ASSEMBLY	TOTAL RECURRING
2-170 STRUCTURE	6.5	2.9	9.4	7.7	9.5	17.2
THERMAL CONTROL	3.1	1.1	4.2	3.7	1.9	5.6
ELECTRICAL POWER	8.1	5.2	13.3	11.5	14.2	25.7
COMMUNICATIONS	1.8	1.0	2.8	1.6	2.3	3.9
DATA HANDLING	9.7	6.0	15.7	11.4	12.8	24.2
STABILITY AND CONTROL	11.4	5.8	17.2	24.1	22.8	46.9
AUXILIARY PROPULSION	3.7	3.4	7.2	11.0	6.9	17.6
SPACECRAFT MISSION EQUIPMENT	43.5	25.4	68.9	70.9	70.7	141.6
			45.2			93.5
SATELLITE QUALIFICATION UNIT(S)			114.1			234.9
GSE (AGE)			3.0			
LAUNCH SITE SUPPORT			14.4			4.1
CONTRACTOR FEE			5.8			10.2
TOTAL SATELLITE			134.3			249.4
AVERAGE UNIT COST						49.8
TOTAL SATELLITE RDT+E AND RECURRING COST						383.8

SATELLITE SYSTEM EO-G9A (SSUS-DESPIN)

ASSEMBLY DESCRIPTIONS - - DESIGN NUMBER 1 * * * *

STARILIZATION AND CONTROL

IDENT	TYPE	NO.	UNIT WEIGHT	UNIT VOLUME	UNIT POWER	D.E. COST	T.L. COST	VEHICLE PROD. COST	VEHICLE ENG. COST
204	VALVE DRIVER	4	3.5	-0.0	-1.0	216753.9	13422.5	89588.5	142050.9
301	SUN SENSOR W/ELECT	2	.9	.0	1.0	249110.0	188550.0	110288.6	118819.6
1003	CONTR ELECT	1	31.0	-0.0	-0.0	2436340.0	1357560.0	364485.9	661689.0
1202	HOR SENSOR	2	13.0	-0.0	-0.0	2256943.5	693864.0	927555.8	927589.2
1302	NOM WHL	6	17.7	-0.0	-0.0	191582.5	213690.0	264187.8	161113.1
1703	INT GYRO	6	5.3	-0.0	-0.0	600531.7	512856.0	419254.6	505022.8
2104	STAR SENSOR	6	10.0	-0.0	-0.0	628500.0	817050.0	800050.0	528543.6
1203	HOR SENSOR	1	1.0	-0.0	-0.0	610902.0	120672.0	72268.8	144506.7
117	RAPTA	1	135.0	-0.0	-0.0	628500.0	125700.0	251369.0	148669.4

AUXILIARY PROPULSION

IDENT	TYPE	NO.	UNIT WEIGHT	UNIT VOLUME	UNIT POWER	D.E. COST	T.E. COST	VEHICLE PROD. COST	VEHICLE ENG. COST
810	MONO THRUST NR-50A	14	1.2	.1	1.0	247189.0	415564.2	155515.3	338051.6
1309	THRUSTER	4	14.0	-0.0	-0.0	1382700.0	1382700.0	386359.5	95841.2

DATA PROCESSING AND INSTRUMENTATION

IDENT	TYPE	NO.	UNIT WEIGHT	UNIT VOLUME	UNIT POWER	D.E. COST	T.E. COST	VEHICLE PROD. COST	VEHICLE ENG. COST
108	GEN. PURP. PROC. AMPP	1	20.0	.1	100.0	5405100.0	3582450.0	1508217.5	1278557.1
109	DTU AND CDU	1	18.0	-0.0	-0.0	942750.0	597075.0	345633.2	223004.2

COMMUNICATIONS

IDENT	TYPE	NO.	UNIT WEIGHT	UNIT VOLUME	UNIT POWER	D.E. COST	T.E. COST	VEHICLE PROD. COST	VEHICLE ENG. COST
101	BASEBAND ASM. UNIT	2	.9	.0	.5	36453.0	11313.0	36197.3	14981.6
202	ANTENNA	1	2.1	2.1	-0.0	130728.0	100560.0	14453.6	30923.2
203	ANTENNA	2	1.0	1.0	-0.0	84219.8	57822.0	27148.0	34612.7
301	TRANSMITTER	2	1.9	.2	10.0	62850.0	62850.0	45246.6	25830.4
305	TRANSMITTER	2	2.8	.0	90.0	138270.0	138270.0	62217.1	56526.8
401	RECEIVER	1	4.0	.4	3.0	95532.0	214947.0	43989.7	22597.8
602	COMPLEXER	2	1.8	.0	1.0	17849.4	12570.0	25338.1	7335.8
603	MISC	1	16.0	-0.0	-0.0	49023.0	50280.0	55301.3	11596.2
605	MISC	1	5.0	-0.0	-0.0	31425.0	23883.0	26393.8	7433.5

2-171

ELECTRICAL POWER

IDENT TYPE	NO.	UNIT WEIGHT	UNIT VOLUME	UNIT POWER	D.E. COST	T.E. COST	VEHICLE PROD. COST	VEHICLE ENG. COST
206 BATTERY CELL	3	24.4	.1	-6.6	810537.2	967261.5	472218.8	45232.1

EQUIPMENTS USING COST ESTIMATING RELATIONSHIPS

NAME	WEIGHT	D.E. COST	T.E. COST	VEHICLE PROD. COST	VEHICLE ENG. COST
SOLAR ARRAY	85.0	399534.2	395183.8	738105.9	94508.4
HARNES	78.0	555186.6	482316.2	198503.0	131327.4
THERMAL CONTROL	79.0	203980.8	774676.1	280219.9	482517.6
POWER CONVERTERS	33.0	919587.0	534327.5	246749.9	215159.6
PROPULSION FEED SYS.		819099.1	594917.1	451299.3	193755.0
STRUCTURE	497.0	4263737.1	2000339.8	1377854.6	1008571.8
POWER CONTROL UNITS	77.0	2646517.5	1260488.1	426327.8	626024.3

SPACECRAFT DESIGN AND COST MODEL

SATELLITE SYSTEM EO-P9A (SSUS)

(MILLIONS OF 1975 DOLLARS)

SUBSYSTEM COST	-----RDT+E-----			-----RECURRING-----		
	DESIGN ENGINEERING	TEST AND EVALUATION	TOTAL RDT+E	PRODUCTION ENGINEERING	FA3 AND ASSEMBLY	TOTAL RECURRING
2-173 STRUCTURE	6.4	2.8	9.3	7.6	9.4	17.1
THEMAL CONTROL	2.9	1.0	3.9	3.4	1.8	5.2
ELECTRICAL POWER	8.1	5.2	13.2	11.4	14.2	25.6
COMMUNICATIONS	1.0	1.0	1.9	1.6	2.3	3.9
DATA HANDLING	9.7	6.0	15.7	11.4	12.8	24.2
STABILITY AND CONTROL	10.4	5.7	16.2	22.6	24.8	43.4
AUXILIARY PROPULSION	1.5	1.1	2.6	3.9	2.9	6.8
SPACECRAFT MISSION EQUIPMENT	40.0	22.8	62.8	62.1	64.4	126.5
			45.2			93.5
SATELLITE QUALIFICATION UNIT(S)			108.0			219.8
GSE (AGE)			4.0			
			13.6			
LAUNCH SITE SUPPORT						3.9
CONTRACTOR FEE			5.3			9.1
TOTAL SATELLITE			127.0			233.0
AVERAGE UNIT COST						46.6
TOTAL SATELLITE RDT+E AND RECURRING COST						360.0

SATELLITE SYSTEM EO-97A (TUG OR IUS)

* * * ASSEMBLY DESCRIPTIONS - - DESIGN NUMBER 1 * * * *

STABILIZATION AND CONTROL

IDENT TYPE	NO.	UNIT WEIGHT	UNIT VOLUME	UNIT POWER	D.E. COST	T.E. COST	VEHICLE PROD. COST	VEHICLE ENG. COST
301 SUN SENSOR W/ELECT	1	.9	.0	1.0	289110.0	189550.0	61271.3	69387.9
1704 CONT ELECT	1	49.0	-0.0	-0.0	2702550.0	1759600.0	443886.5	639278.5
1202 HOR SENSOR	2	13.0	-0.0	-0.0	2256343.5	633854.0	927555.8	927563.2
1302 MON WHL	3	17.0	-0.0	-0.0	191532.5	213690.0	264167.3	161113.1
1703 INT GYRO	3	5.3	-0.0	-0.0	500531.7	512856.0	419254.6	505022.8
2104 STAR SENSOR	2	10.0	-0.0	-0.0	528500.0	817050.0	316726.4	253303.6

AUXILIARY PROPULSION

IDENT TYPE	NO.	UNIT WEIGHT	UNIT VOLUME	UNIT POWER	D.E. COST	T.E. COST	VEHICLE PROD. COST	VEHICLE ENG. COST
803 THRUSTER MR-00	14	.6	.1	1.0	193930.9	448330.0	95603.0	265139.3

DATA PROCESSING AND INSTRUMENTATION

IDENT TYPE	NO.	UNIT WEIGHT	UNIT VOLUME	UNIT POWER	D.E. COST	T.E. COST	VEHICLE PROD. COST	VEHICLE ENG. COST
107 GEN. PURP. PRO. STARC	3	25.0	.1	40.0	5097707.0	2220750.0	446534.6	3315704.2
202 SPEC. PURP. PRO. JTO.	2	9.0	.9	3.0	226260.0	203005.5	203609.8	92359.3

COMMUNICATIONS

IDENT TYPE	NO.	UNIT WEIGHT	UNIT VOLUME	UNIT POWER	D.E. COST	T.E. COST	VEHICLE PROD. COST	VEHICLE ENG. COST
101 BASEBAND ASM. UNIT	2	.9	.0	.3	36453.0	11313.0	36197.3	14991.6
202 ANTENNA	1	2.1	2.1	-0.0	130725.0	100550.0	14453.9	30923.2
203 ANTENNA	2	1.0	1.0	-0.0	84219.0	57822.0	27143.0	39612.7
301 TRANSMITTER	2	1.3	.2	10.7	62850.0	62850.0	45245.6	23230.4
302 TRANSMITTER	2	2.1	.2	16.0	290367.0	106030.0	69453.6	119336.3
401 RECEIVER	1	4.0	.4	3.0	95532.0	214947.0	43989.7	22537.8
502 DIPLEXER	2	1.8	.0	1.0	17849.4	12570.0	25338.1	7335.8

2-174

SPACECRAFT DESIGN AND COST MODEL

SATELLITE SYSTEM AS-05A (SSUS)

(MILLIONS OF 1975 DOLLARS)

SUBSYSTEM COST	-----RDT+E-----			-----RECURRING-----		TOTAL RECURRING
	DESIGN ENGINEERING	TEST AND EVALUATION	TOTAL RDT+E	PRODUCTION ENGINEERING	FAB AND ASSEMBLY	
STRUCTURE	4.6	2.0	6.6	5.5	7.2	12.6
THERMAL CONTROL	2.2	.8	3.0	2.6	1.3	3.9
ELECTRICAL POWER	4.4	3.7	8.1	7.1	11.0	18.1
COMMUNICATIONS	.5	.9	1.4	1.5	1.9	3.4
DATA HANDLING	.5	.6	1.1	1.0	1.3	2.8
STABILITY AND CONTROL	10.3	6.3	16.6	17.3	13.9	31.7
AUXILIARY PROPULSION	1.4	.8	2.2	3.6	2.0	5.6
SPACECRAFT MISSION EQUIPMENT	24.4	15.0	39.4	39.2	39.2	78.4
SATELLITE QUALIFICATION UNIT(S)			52.0			104.2
GSE (AGE)			0.0			
LAUNCH SITE SUPPORT			9.7			3.0
CONTRACTOR FEE			3.4			5.7
TOTAL SATELLITE			75.1			117.0
AVERAGE UNIT COST						23.4
TOTAL SATELLITE RDT+E AND RECURRING COST						132.1

2-175

ELECTRICAL POWER

IDENT. TYPE	NO.	UNIT WEIGHT	UNIT VOLUME	UNIT POWER	J.F. COST	T.E. COST	VEHICLE PROD. COST	VEHICLE ENG. COST
209 BATTERY CELL	3	35.9	.1	-0.0	1035989.3	1221204.0	571767.6	563332.1

EQUIPMENTS USING COST ESTIMATING RELATIONSHIPS

NAME	WEIGHT	D.E. COST	T.E. COST	VEHICLE PROD. COST	VEHICLE ENG. COST
SOLAR ARRAY	96.0	444143.1	419376.8	783189.9	105060.5
HARNESS	72.0	524305.1	460252.4	187012.5	124022.5
THERMAL CONTROL	75.0	1987489.5	754309.3	272097.9	470133.6
POWER CONVERTERS	0.0	0.0	0.0	0.0	0.0
PROPULSION FEED SYS.		519407.4	230543.0	176615.3	146518.6
STRUCTURE	192.0	4324697.4	1996398.1	1072926.3	1022991.8
POWER CONTROL UNITS	39.0	1775250.5	1027106.5	359012.0	419929.2

SPACECRAFT DESIGN AND COST MODEL

SATELLITE SYSTEM AS-05A (SSUS)

(MILLIONS OF 1975 DOLLARS)

SUBSYSTEM COST	-----RDT+E-----			-----RECURRING-----		
	DESIGN ENGINEERING	TEST AND EVALUATION	TOTAL RDT+E	PRODUCTION ENGINEERING	FAB AND ASSEMBLY	TOTAL RECURRING
STRUCTURE	4.6	2.0	6.6	5.5	7.2	12.6
THERMAL CONTROL	2.2	.8	3.0	2.6	1.3	3.3
ELECTRICAL POWER	4.4	3.7	8.1	7.1	11.0	18.1
COMMUNICATIONS	.5	.9	1.4	1.3	1.9	3.4
DATA HANDLING	.5	.6	1.1	1.0	1.3	2.3
STABILITY AND CONTROL	10.3	6.3	16.6	17.3	13.9	31.7
AUXILIARY PROPULSION	1.4	.8	2.2	3.6	2.0	5.6
SPACECRAFT MISSION EQUIPMENT	24.4	15.0	39.4	39.2	39.2	78.4
SATELLITE QUALIFICATION UNIT(S)			52.0			104.0
GSE (AGE)			0.0			0.0
LAUNCH SITE SUPPORT			9.7			3.0
CONTRACTOR FEES			3.4			5.7
TOTAL SATELLITE			75.1			117.0
AVERAGE UNIT COST						23.4
TOTAL SATELLITE RDT+E AND RECURRING COST						172.1

2-177

SATELLITE SYSTEM EO-07A (SSUS)

*** ASSEMBLY DESCRIPTIONS - - DESIGN NUMBER 1 ***

STABILIZATION AND CONTROL

IDENT	TYPE	NO.	UNIT WEIGHT	UNIT VOLUME	UNIT POWER	D.E. COST	T.E. COST	VEHICLE PROD. COST	VEHICLE ENG. COST
301	SUN SENSOR W/ELECT	2	.9	.0	1.0	289110.0	188550.0	110288.6	118819.6
1004	CONT ELECT	1	49.0	-0.0	-0.0	2702550.0	1759800.0	483886.5	633278.6
1203	HOR SENSOR	1	1.0	-0.0	-0.0	610902.0	120672.0	72256.8	144506.7
1302	HOR WHL	6	17.0	-0.0	-0.0	191582.5	213690.0	264187.6	161113.1
1703	INT GYRO	6	5.3	-0.0	-0.0	600531.7	512855.0	419254.6	505022.8
401	ROTATION DAMPER	1	4.0	.9	0.0	194835.0	31425.0	11311.6	46087.5
1005	CONT ELECT	1	6.0	-0.0	-0.0	716490.0	483945.0	123171.1	169483.2
1202	HOR SENSOR	2	13.0	-0.0	-0.0	2256943.5	693864.0	927355.8	927568.2
2104	STAR SENSOR	2	10.0	-0.0	-0.0	628500.0	817050.0	315726.4	258303.6

AUXILIARY PROPULSION

IDENT	TYPE	NO.	UNIT WEIGHT	UNIT VOLUME	UNIT POWER	D.E. COST	T.E. COST	VEHICLE PROD. COST	VEHICLE ENG. COST
603	THRUSTER MR-6C	14	.6	.1	1.0	193530.9	448330.0	96608.0	265139.3
810	MONO THRUST MR-50A	2	1.2	.1	1.0	214947.0	214947.0	23682.8	88339.8

DATA PROCESSING AND INSTRUMENTATION

IDENT	TYPE	NO.	UNIT WEIGHT	UNIT VOLUME	UNIT POWER	D.E. COST	T.E. COST	VEHICLE PROD. COST	VEHICLE ENG. COST
107	GEN. PURP. PRO. SMARC	3	25.0	.1	40.0	6097707.0	8220780.0	4456934.6	3315704.2
202	SPEC. PURP. PRO. DTU.	2	9.0	.9	3.0	226260.0	203005.5	293609.8	92989.3

COMMUNICATIONS

IDENT	TYPE	NO.	UNIT WEIGHT	UNIT VOLUME	UNIT POWER	D.E. COST	T.E. COST	VEHICLE PROD. COST	VEHICLE ENG. COST
101	BASEBAND ASM. UNIT	2	.9	.0	.5	36453.0	11313.0	36147.3	14981.6
202	ANTENNA	1	2.1	2.1	-0.0	130728.0	100560.0	14453.8	30923.2
203	ANTENNA	2	1.0	1.0	-0.0	84219.0	97822.0	27148.0	34612.7
301	TRANSMITTER	2	1.9	.2	10.0	62850.0	62850.0	45246.6	25830.4
302	TRANSMITTER	2	2.1	.2	16.0	290367.0	106030.8	69453.8	119336.3
401	RECEIVER	1	4.0	.4	3.0	95532.0	214947.0	43489.7	22597.8
602	DIPLEXER	2	1.8	.0	1.0	17649.4	12570.0	25338.1	7335.8
605	MISC	1	5.0	-0.0	-0.0	31425.0	23883.0	25393.8	7433.5

2-178

ORIGINAL PAGE IS
OF POOR QUALITY

ELECTRICAL POWER

IDENT	TYPE	UNIT NO.	UNIT WEIGHT	UNIT VOLUME	UNIT POWER	D.E. COST	T.E. COST	VEHICLE PROJ. COST	VEHICLE ENG. COS
209	BATTERY CELL	3	35.9	.1	-0.0	1035989.3	1221804.0	571757.0	563332.1

EQUIPMENTS USING COST ESTIMATING RELATIONSHIPS

NAME	WEIGHT	D.E. COST	T.E. COST	VEHICLE PROJ. COST	VEHIC ENG. C
SOLAR ARRAY	96.0	444143.1	419975.8	783189.9	10506
HARNESS	74.0	534677.6	467688.9	190869.0	12647
THERMAL CONTROL	75.0	1987489.5	754809.3	272097.9	47013
POWER CONVERTERS	0.0	0.0	0.0	0.0	
PROPULSION FEED SYS.		678169.6	281104.4	214907.9	16041
STRUCTURE	216.0	4484640.7	2074381.7	1106682.4	106082
POWER CONTROL UNITS	39.0	1775250.5	1027106.5	339012.0	41992

2-179

SPACECRAFT DESIGN AND COST MODEL

SATELLITE SYSTEM AS-05A (TUG OR IUS)

(MILLIONS OF 1975 DOLLARS)

SUBSYSTEM COST.	-----RDT+E-----			-----RECURRING-----		
	DESIGN ENGINEERING	TEST AND EVALUATION	TOTAL RDT+E	PRODUCTION ENGINEERING	FA3 AND ASSEMBLY	TOTAL RECURRING
2-180 STRUCTURE	4.5	2.0	6.5	5.3	7.2	12.5
THERMAL CONTROL	2.2	.8	3.0	2.6	1.3	3.9
ELECTRICAL POWER	4.4	3.7	8.1	7.1	11.9	19.1
COMMUNICATIONS	.8	.8	1.7	1.4	1.7	3.2
DATA HANDLING	.5	.6	1.1	1.0	1.3	2.3
STABILITY AND CONTROL	8.0	5.3	13.3	14.7	12.1	26.8
AUXILIARY PROPULSION	1.0	.4	1.4	2.3	1.5	4.4
SPACECRAFT	21.5	13.6	35.0	35.0	36.9	71.9
MISSION EQUIPMENT			22.6			30.0
SATELLITE			57.6			101.7
QUALIFICATION UNIT(S)			0.0			
GSE (AGE)			8.9			
LAUNCH SITE SUPPORT						2.3
CONTRACTOR FFE			3.1			5.2
TOTAL SATELLITE			59.6			109.9
AVERAGE UNIT COST						22.0
TOTAL SATELLITE RDT+E AND RECURRING COST						179.5

SATELLITE SYSTEM AS-05A (TUG OR IUS)

* * * ASSEMBLY DESCRIPTIONS - - DESIGN NUMBER 1 * * * *

STABILIZATION AND CONTROL

IDENT	TYPE	NO.	UNIT WEIGHT	UNIT VOLUME	UNIT POWER	D.E. COST	T.E. COST	VEHICLE PROD. COST	VEHICLE ENG. COST
301	SUN SENSOR W/ELECT	1	.9	.0	1.0	289110.0	188550.0	61271.3	63397.9
303	FINE SUN SENSOR	2	6.5	-0.0	-0.1	942750.0	377100.0	347333.4	357455.4
1004	CONT ELECT	1	49.0	-0.0	-0.1	2702550.0	1750800.0	483885.9	639278.6
1393	MON WHEEL	6	5.3	-0.0	-0.0	81107.9	83339.1	126350.7	63208.5
1703	INT GYRO	6	5.3	-0.0	-0.1	600531.7	512856.0	419254.6	505022.9
2104	STAR SENSOR	2	10.0	-0.0	-0.0	628500.0	317050.0	316726.4	252393.6

AUXILIARY PROPULSION

IDENT	TYPE	NO.	UNIT WEIGHT	UNIT VOLUME	UNIT POWER	D.E. COST	T.E. COST	VEHICLE PROD. COST	VEHICLE ENG. COST
503	THRUSTER	14	.6	.1	1.0	193530.9	112052.5	36606.0	265139.3

DATA PROCESSING AND INSTRUMENTATION

IDENT	TYPE	NO.	UNIT WEIGHT	UNIT VOLUME	UNIT POWER	D.E. COST	T.E. COST	VEHICLE PROD. COST	VEHICLE ENG. COST
203	DIO	2	3.0	-0.0	-0.1	174301.6	253937.3	142526.9	71840.7
204	DECODER	2	4.0	-0.0	-0.0	139270.0	143298.0	172155.9	55826.8

2-181

COMMUNICATIONS

IDENT	TYPE	NO.	UNIT WEIGHT	UNIT VOLUME	UNIT POWER	D.E. COST	T.E. COST	VEHICLE PROD. COST	VEHICLE ENG. COST
101	BASEBAND ASM. UNIT	2	.9	.0	.5	36453.0	11313.0	36197.3	14981.6
202	ANTENNA	1	2.1	2.1	-0.1	130723.0	100550.0	14653.3	39083.2
203	ANTENNA	2	1.0	1.0	-0.1	84219.0	57822.0	27149.0	34612.7
301	TRANSMITTER	2	1.3	.2	10.1	62350.0	62650.0	45246.5	25830.4
305	TRANSMITTER	2	2.5	.0	40.0	123700.0	123700.0	96553.3	51650.7
401	RECEIVER	1	4.0	.4	3.1	95532.0	214947.0	43989.7	22597.9
602	DIPLEXER	2	1.3	.0	1.0	17849.4	12570.0	25339.1	7335.8

ELECTRICAL POWER

IDENT	TYPE	NO.	UNIT WEIGHT	UNIT VOLUME	UNIT POWER	D.E. COST	T.E. COST	VEHICLE PRD. COST	VEHICLE ENG. COST
206	BATTERY CELL	3	24.4	.1	-0.1	300537.2	957231.5	472213.8	435302.1

EQUIPMENTS USING COST ESTIMATING RELATIONSHIPS

NAME	WEIGHT	D.E. COST	T.E. COST	VEHICLE PRD. COST	VEHICLE ENG. COST
SOLAR ARRAY	87.0	329614.1	342309.6	655335.5	77969.0
HARNESS	44.0	363688.9	345045.5	129577.5	87212.0
THERMAL CONTROL	41.0	1451457.1	551234.7	190636.7	343337.0
POWER CONVERTERS	0.0	0.0	0.0	0.0	0.0
PROPULSION FLEW SYS.		449235.4	178219.2	136396.3	106265.0
STRUCTURE	170.0	2962570.5	1364776.8	1033129.6	700785.5
POWER CONTROL UNITS	26.0	1399246.0	309100.7	333472.7	330986.7

2-182

SPACECRAFT DESIGN AND COST MODEL

SATELLITE SYSTEM EO-07A (SSUS)

(MILLIONS OF 1975 DOLLARS)

2-183

SUBSYSTEM COST	-----RDT+E-----			-----RECURRING-----		
	DESIGN ENGINEERING	TEST AND EVALUATION	TOTAL RDT+E	PRODUCTION ENGINEERING	FA3 AND ASSEMBLY	TOTAL RECURRING
STRUCTURE	6.8	3.0	9.8	8.1	7.6	15.7
THERMAL CONTROL	3.0	1.1	4.1	3.6	1.9	5.5
ELECTRICAL POWER	5.8	4.5	10.3	9.3	13.1	22.4
COMMUNICATIONS	1.1	.8	2.0	2.0	2.0	4.0
DATA HANDLING	9.6	12.0	21.7	25.0	32.2	56.2
STABILITY AND CONTROL	12.5	5.9	19.4	22.6	18.8	41.5
AUXILIARY PROPULSION	1.7	1.4	3.0	3.9	2.4	6.3
SPACECRAFT MISSION EQUIPMENT	40.6	29.7	70.3	75.5	78.3	153.3
			32.6			62.5
SATELLITE QUALIFICATION UNIT(S)			102.9			216.1
GSE (AGE)			0.0			
LAUNCH SITE SUPPORT			13.6			4.4
CONTRACTOR FEE			5.9			11.1
TOTAL SATELLITE			122.5			231.7
AVERAGE UNIT COST						46.3
TOTAL SATELLITE RDT+E AND RECURRING COST						354.3

STABILIZATION AND CONTROL

IDENT	TYPE	NO.	UNIT WEIGHT	UNIT VOLUME	UNIT POWER	D.E. COST	T.E. COST	VEHICLE PROD. COST	VEHICLE ENG. COST
301	SUN SENSOR W/ELECT	2	.3	.0	1.0	239110.0	134550.0	110233.5	119819.6
303	FINE SUN SENSOR	2	5.5	-0.0	-0.0	342730.0	377100.0	347837.5	397455.4
1604	CONT ELECT	1	49.0	-0.0	-0.0	2792550.0	1739300.0	484885.5	539273.6
1303	MON WHEEL	5	5.3	-0.0	-0.0	81107.9	53339.1	126359.7	58203.5
1703	INT GYRO	6	5.3	-0.0	-0.0	500531.7	512856.0	419254.6	505022.8
2104	STAR SENSOR	2	10.0	-0.0	-0.0	528500.0	517050.0	316725.4	203393.6
401	MUTATION DAMPER	1	4.0	.9	0.0	194835.0	31425.0	11311.6	45097.5
1605	CONT ELECT	1	6.0	-0.0	-0.0	716490.0	483945.0	123171.1	169493.2
1203	HOL SENSOR	1	1.0	-0.0	-0.0	510962.0	128672.0	72264.8	144506.7

AUXILIARY PROPULSION

IDENT	TYPE	NO.	UNIT WEIGHT	UNIT VOLUME	UNIT POWER	D.E. COST	T.E. COST	VEHICLE PROD. COST	VEHICLE ENG. COST
803	THRUSTER MR-60	14	.6	.1	1.1	193530.3	112032.5	95603.0	255139.3
510	MONO THRUST MR-50A	2	1.2	.1	1.0	214947.0	21947.0	29862.8	83339.8

DATA PROCESSING AND INSTRUMENTATION

IDENT	TYPE	NO.	UNIT WEIGHT	UNIT VOLUME	UNIT POWER	D.E. COST	T.E. COST	VEHICLE PROD. COST	VEHICLE ENG. COST
203	DTU	2	5.0	-0.0	-0.0	174501.6	269937.3	142525.9	71340.7
204	DECODER	2	4.0	-0.0	-0.0	138270.0	143238.0	122155.9	56826.3

COMMUNICATIONS

IDENT	TYPE	NO.	UNIT WEIGHT	UNIT VOLUME	UNIT POWER	D.E. COST	T.E. COST	VEHICLE PROD. COST	VEHICLE ENG. COST
101	BASERAND ASM. UNIT	2	.9	.0	.5	36453.0	11313.0	36137.3	14981.5
202	ANTENNA	1	2.1	2.1	-0.0	130728.0	106550.0	14453.9	30923.2
203	ANTENNA	2	1.0	1.0	-0.0	84219.0	57822.0	27143.0	34612.7
301	TRANSMITTER	2	1.9	.2	10.0	62850.0	62850.0	45240.6	23830.4
305	TRANSMITTER	2	2.5	.0	40.0	125700.0	125700.0	56553.3	51560.7
401	RECEIVER	1	4.0	.4	3.0	39932.0	214947.0	43983.7	22597.8
402	DIPLEXER	2	1.3	.0	1.0	17843.4	12570.0	25339.1	7335.8
605	MISC	1	5.0	-0.0	-0.0	31425.0	23633.0	25393.8	7433.5

2-184

ORIGINAL PAGE IS
OF POOR QUALITY

ELECTRICAL POWER

IDENT	TYPE	NO.	UNIT WEIGHT	UNIT VOLUME	UNIT POWER	D.E. COST	T.E. COST	VEHICLE PROD. COST	VEHICLE ENG. COST
Z06	BATTERY CELL	3	24.4	.1	70.0	800537.2	957261.5	472213.3	35302.1

EQUIPMENTS USING COST ESTIMATING RELATIONSHIPS

NAME	WEIGHT	D.E. COST	T.E. COST	VEHICLE PROD. COST	VEHICLE ENG. COST
SOLAR ARRAY	84.0	329514.1	342309.6	655805.5	77969.0
HARNESS	46.0	380595.1	354135.3	133940.7	90028.4
THERMAL CONTROL	40.0	1451457.1	551234.7	190636.7	343337.0
POWER CONVERTERS	0.0	0.0	0.0	0.0	0.0
PROPULSION FEED SYS.		529070.9	211167.5	161919.9	125149.7
STRUCTURE	170.0	3034213.6	1397780.8	1039129.6	717732.4
POWER CONTROL UNITS	26.0	1399246.0	909100.7	333472.7	330936.7

2-185

SECTION 3

SUBTASK II: SSUS SIZING STUDY AND SUBTASK III: SSUS APPLICABILITY TO OVERALL NASA MISSION MODEL

The SSUS stage sizing was based on the non-communication/navigation geosynchronous payloads, and these analyses extended as one effort into consideration of resizing for the overall 1981-1991 NASA mission model (Table 3-1). All geosynchronous missions (Table 3-2) were baselined to a 296.32-km (160-nmi), 28.4-deg, inclined circular parking orbit for the Orbiter with a geosynchronous transfer orbit perigee velocity requirement of 2.451 km/sec (8042 ft/sec) and an apogee velocity requirement for circularization of 1.779 km/sec (5838 ft/sec). Planetary missions utilized the same parking orbit as geosynchronous missions and other than geosynchronous earth orbits utilized different Orbiter inclinations where appropriate.

The geosynchronous mission sizing studies indicate that the entire model can be accomplished efficiently with three existing motors and two new motors. The two new motors could accomplish the entire geosynchronous model, but more efficient packaging of small payloads in the Orbiter bay and less extreme motor off-loading are achieved through the addition of three existing smaller motors. The new motor No. 1 is used as a perigee kick motor (PKM) with propellant weights from 6009 kg (13,250 lb) to 3719 kg (8200 lb). The new motor No. 2 is used as a PKM with 1814 kg (4000 lb) and 1270 kg (2800 lb) of propellant and as an apogee kick motor (AKM) with 1633 kg (3600 lb) of propellant. The existing TE-M-364-4 and -3 and TE-M-616 motors are used with off-loading as AKMs.

The overall mission model introduces new driver missions. The EO-56A environmental monitoring satellite is in a 1,695-km (914-nmi) circular orbit at 102.97 deg inclination and requires a mission design using three motors to make the plane change at a 5556-km (3000-nmi) high apogee and recircularize down to 1695 km from an ETR Orbiter launch. The three

Table 3-1. Upper Stage Payload Model

CODE		PAYLOAD NAME	CY FLIGHT SCHEDULE												TOTAL FLIGHTS
SSPD	PLD MODEL		80	81	82	83	84	85	86	87	88	89	90	91	
<u>ASTRONOMY</u>															
AS-02-A	AST-1	LYMAN ALPHA EXP		1		1		1						3	
AS-05-A	AST-1	ADV RADIO AST EXP								1				1	
AS-16-A	AST-8	LARGE RADIO OBS ARRAY						1						1	
AS-16-R	AST-8V	LARGE RADIO REVISITS							1		1		1	3	
<u>PHYSICS</u>															
AP-01-A	PHY-1A	EXPLORER-UPPER ATM					1			1	1	1	1	5	
AP-02-A	PHY-1B	EXPLORER-MED ALT		1			1			1	1	1	1	6	
AP-03-A	PHY-1C	EXPLORER-HIGH ALT			1	1		1	1	1				5	
AP-04-A	PHY-2A	GRAVITY REL-LEO				1								1	
AP-05-A	PHY-3A	ENVIRON PERTURB A				1		1						2	
AP-06-A	PHY-2B	GRAVITY REL-SOLAR						1					1	2	
AP-07-A	PHY-3B	ENVIRON PERTURB B									1			1	
AP-08-A	PHY-4	HELIO INTERSTELL								1				1	
<u>EARTH OBS</u>															
EO-07-A	EO-7	SYNC MET SAT								1				1	
EO-09-A	EO-4A	SYNC EARTH OBS SAT				1		1						2	
EO-09-A	EO-4B	SYNC EARTH OBS SAT								2			2	6	
EO-10-A	EO-5E	SEVERE STORM OBS	1			1		1			1			4	
EO-57-A	NN/D-9	RGN SYNC MET SAT		1	1		1	1		1		1		6	
EO-58-A	NN/D-10	GEOSYNC OPR MET SAT		1	1	1		1		1	1	1	1	8	
EO-59-A	NN/D-12	GEOSYNC ERS								2		2		4	
EO-61-A	NN/D-11	EARTH RES SURVEY SAT	1	1	1	1	1	1	1	1	1	1	1	12	
EO-62-A	NN/D-13	FGN SYNC EOS								1	2		1	4	
EO-12-A	EO6	TIROS				1				1				2	
EO-56-A	NN/D-8	ENVIRON MONITORING	1	1	1			1	1	1	1		1	9	
<u>EARTH AND OCEAN PHYSICS</u>															
OP-01-A	EOP-4	GEOPAUSE						1						1	
OP-06-A	EOP-9	MAG MONITOR SAT						1			1			2	
TOTAL												92			

8

23

58

3

Table 3-1. Upper Stage Payload Model (Continued)

CODE		PAYLOAD NAME	CY FLIGHT SCHEDULE													TOTAL FLIGHTS
SSPD	PLD MODEL		80	81	82	83	84	85	86	87	88	89	90	91		
		<u>COMM/NAV</u>														
CN-51-A	NN-D-1	INTELSAT	3			2	3	2	2			2	3	2	19	
CN-52-A	NN-D-2A	U. S. DOMSAT-A	1	2	2	1									6	
CN-53-A	NN-D-2B	U. S. DOMSAT-B					1	1	2	2	3	2	2	1	14	
CN-54-A	NN-D-3	DISASTER WARNING		1	1			1					1		4	
CN-55-A	NN-D-4	TRAFFIC MANAGEMENT	2	2	1	1	1		1		1		1		10	
CN-56-A	NN/D-5	FGN COMM SAT		1	1	1	1	1	1	1	1	1	1	1	11	
CN-58-A	NN/D-2C	U. S. DOMSAT-C (TDRS)				3					3				6	
CN-59-A	NN/D-6	COMM R&D PROTOTYPE						1			1		1		3	
		<u>PLANETARY</u>														
PL-28-A		PIONEER MARS PENT'R		1											1	
PL-29-A		MARS POLAR ORBITER					1								1	
PL-01-A	PL-7	MARS SURF SAM RET										2			2	
PL-07-A	PL-11	VENUS ORB IMAGING RAD				2									2	
PL-10-A	PL-14	VENUS LARGE LANDER														
PL-09-A	PL-13	MERCURY ORBITER				1									1	
PL-13-A	PL-20	PIONEER JUP ORB/PROBE	1												1	
PL-12-A	PL-19	MARINER JUP ORBITER						1							1	
PL-22-A	PL-17	PION SAT/URS/TITAN			1	1	1								3	
PL-14-A	PL-21	MARINER SAT ORB								2					2	
PL-30-A		TITAN SOFT LANDER														
PL-10-A	PL-23	JUP SAT ORB/LANDER														
PL-31-A		JUP SWGBY OUT-OF-ECLIP	1												1	
PL-21-A	PL-25	ENCKE BALLISTIC FLYBY	1												1	
PL-32-A		OUT-OF-ECLIP SOLAR OBS					1								1	
PL-19-A	PL-27	HALLEY FLYBY						1							1	
PL-33-A		TEMPLE-2 REND							2						2	
PL-20-A	PL-28	ASTEROID REND								2					2	
		<u>LUNAR</u>														
LU-01-A	LUN-2	LUNAR ORBITER					1		1						2	
LU-02-A	LUN-3	LUNAR ROVER								1	1				2	
LU-03-A	LUN-4	LUNAR HALO										1			1	
LU-04-A	LUN-5	LUNAR SAM RET											1	1	2	
		TOTAL	12	13	11	21	16	15	16	18	20	20	17	15	194	

73

22

7

3-5

Table 3-2. NASA Geosynchronous Payload Characteristics

Payload Code	Name	Weight		Length		Diameter		Stabilization
		kg	lb	m	ft	m	ft	
•EO-57-A (NN/D-9)	FSMS	257	566	3.14	10.3	1.91	6.27	Spin 100 rpm
•EO-57-A (NN/D-10)	GOES	257	566	3.14	10.3	1.91	6.27	Spin 100 rpm
CN-52-A (NN/D-2A)	DOMSAT A	262	577	3.20	10.5	2.20	7.22	Spin 60 rpm
CN-55-A (NN/D-4)	TMS	298	658	1.58	5.18	3.88	12.73	3-Axis
CN-56-A (NN/D-5A)	FCS	310	679	2.36	7.74	1.60	5.25	3-Axis
CN-54-A (NN/D-3)	DWS	582	1284	5.12	16.8	1.40	4.59	3-Axis
CN-58-A (NN/D-2C)	DOMSAT C	865	1908	3.69	12.1	2.18	7.15	Spin (TBD)
CN-59-A (NN/D-6)	COMM R&D	956	2108	6.00	19.68	3.40	11.15	3-Axis
•EO-07-A (EO-7)	ASMS	1247	2750	2.91	9.55	4.21	13.81	3-Axis
•AS-05-A (AST-1C)	ARAE	1202	2650 (pair)	2.47	8.1	4.24	13.91	3-Axis
		601	1325 (single)					
CN-51-A (NN/D-1)	INTELSAT	1472	3245	2.70	8.86	2.50	8.2	3-Axis
CN-53-A (NN/D-2B)	DOMSAT B	1472	3245	2.70	8.86	2.50	8.2	3-Axis
•EO-09-A (EO-4)	SEOS	1474	3250	5.20	17.06	4.30	14.11	3-Axis
•EO-59-A (NN/D-12)	GERS	1474	3250	5.20	17.06	4.30	14.11	3-Axis
•EO-62-A (NN/D-13)	FSEOS	1474	3250	5.20	17.06	4.30	14.11	3-Axis

•Task 2.6 Task I Payloads

ORIGINAL PAGE IS
OF POOR QUALITY

motors are two new motor Nos. 3 with 9070 kg (20,000 lb) of propellant and the TE-M-364-4 with 1033 kg (2279 lb) propellant. Other non-geosynchronous earth orbit missions utilize the existing TE-M-516 with 29 kg (64 lb) propellant and the SVM-3 with 38-kg (84-lb) propellant motor. Considering the planetary portion of the total mission model, the PL-12A Mariner Jupiter Orbiter and PL-14A Mariner Saturn Orbiter planetary missions are beyond the capture of the SSUS due to the 29,478-kg (65,000-lb) Orbiter limit using present technology motors. Advanced technology motors and more refined structural design assumptions might permit capture of these two missions with four-stage vehicles. The rest of the planetary missions can be accomplished by introducing a new motor No. 3 having 9070 kg (20,000 lb) propellant. A three-stage vehicle using two new motor No. 3's and a new motor No. 2 with 1814 kg (4000 lb) of propellant will capture these missions. Two-stage combinations are sufficient for many of the planetary missions.

These capture data are based upon preliminary propulsive stage design studies and are subject to considerable refinement in more detail.* Particularly it should be noted that questions of mission error analyses addressed elsewhere in this study for geosynchronous missions have not been studied for the planetary and non-geosynchronous earth orbit missions.

3.1 PERFORMANCE SIZING ANALYSIS FOR THE SSUS STUDY

3.1.1 Introduction

The concept of a spin-stabilized upper stage (SSUS) has been proposed as the Interim Upper Stage (IUS) for the STS (Space Transportation System) launch concept. Sizing solid motors to accomplish the missions defined in the NASA mission model has been the primary task of this study. A brief look at the influence of vehicle errors on the injection orbit has also

*Note: Some variations in weights quoted for the satellites will be found throughout this report due to the necessity of performing concurrent tasks utilizing available estimates prior to the determination of final weight estimates. However, these variations do not materially affect the analyses and results.

been taken. The approach for performance sizing of the solid motors consisted of investigation of the geosynchronous missions, the non-geosynchronous earth orbit missions, and the planetary missions. Performance sizing only was studied, and no effort was made to define the solid motor materials or dimensions. An objective to use existing motors where possible and to design a minimum number of new motors was followed.

Three techniques are available for controlling the energy output of a solid rocket motor that burns to propellant depletion once ignited. Propellant off-loading is a viable procedure and when planned before a motor is loaded, a large percentage of the total possible propellant load can be removed. A second technique is energy management and consists of trajectory design procedures. Orbit plane change can be non-optimally split between multiple burns, or launch azimuths that avoid direct injection into the desired inclination can be employed. Non-optimum attitudes in pitch and yaw may be used along with motor ignition at non-optimum points in the orbits. The affect of these approaches on orbit errors must be determined before they are implemented. Finally, the use of ballast is acceptable. Ballast can sometimes be used in the adapters between stages rather than applied directly to the spacecraft structure. These three techniques may be used individually or together and thus offer a very flexible mission design scheme. An approach that minimizes the errors at motor burnout is perhaps most acceptable.

3.1.2 Analysis

3.1.2.1 Geosynchronous Missions

Four missions were selected from the geosynchronous model. These weights as given in the NASA model and then as modified for spin considerations are presented in Table 3-3. The mission considerations and velocity increments required from the perigee kick motor (PKM) and apogee kick motor (AKM) are given in Table 3-4. Motor characteristics for use in the design also appear in Table 3-4. Utilizing the equations

$$\Delta V = g I_{SP} \ln \frac{w_o}{w_f}$$

Table 3-3. Task II SSUS Sizing Study

Task I: Geosynchronous Payload Model Drivers				
SSPD Payload Code	EO-09A	EO-07A	AS-05A	EO-57A
NASA Weights, kg (lb)	1474.2 (3250)	1247.4 (2750)	601.0 (1325)	256.7 (566)
Aerospace, Weights,* (Spin/Despin)	1697.4 (3742)	1005.2 (2116)	509.8 (1124)	341.1 (752)

*These values include a spacecraft adapter

Table 3-4. Mission and Motor Characteristics for Performance Sizing

- Park Orbit: 296.32 km (160 nmi) Circular, 28.4 deg inclined
- Final Orbit: 35,786 km (19,323 nmi) Circular, 0 deg inclined
- Velocity Increments: AKM-1.779 km/sec (5838 ft/sec), PKM-2.451 km/sec (8042 ft/sec) (2.25 deg Plane Change with PKM)
- Propellant Mass Fraction: 0.90
- Propellant I_{SP} : AKM-285 sec, PKM-292 sec

$$M_f = \frac{w_p}{w_{TM}}$$

where

w_o = Motor ignition weight

w_f = Motor burnout weight

I_{SP} = Propellant specific impulse

g = Acceleration of gravity
 w_p = Propellant weight
 w_{TM} = Total motor weight
 M_f = Propellant mass fraction

and the previously described values gives the ideal motor propellant loads of Table 3-5. An adapter weight is included in the payload weight for attachment to the AKM, and an AKM/PKM adapter is also included.

Table 3-5. Ideal Motor Performance Design

Payload Code	EO-09A	EO-07A	AS-05A	EO-57A
Payload Including Adapter (Aerospace Weights)	1697.4 (3742)	959.8 (2116)	509.8 (1124)	341.1 (752)
AKM Propellant, kg (lb)	1676.6 (3696)	948.0 (2090)	501.5 (1110)	337.0 (743)
PKM Propellant, kg (lb)	6012.9 (13,256)	3399.7 (7495)	1805.3 (3980)	1208.8 (2665)
AKM Ignition Weight, kg (lb)	3560.3 (7849)	2013.0 (4438)	1069.1 (2357)	715.8 (1578)
PKM Ignition Weight, kg (lb) (Includes AKM/ PKM Adapter*)	10,455 (23,049)	5911.3 (13,032)	3138.9 (6920)	2102.0 (4634)

* Adapter design weight is 6 percent of the weight it must carry

Comparing these propellant weights to existing motors indicates the need for two new motors. Use of three existing motors appears feasible. The propellant off-load approach is taken, and motor selection for these four missions is made and presented in Table 3-6. Table 3-7 contains characteristics of these motors. The 0.6 percent off-load of the PKM for mission EO-09A could have been reduced to zero with another pass through the sizing equations, but such a procedure appears unwarranted in

Table 3-6. Geosynchronous Missions Motor Selection Based on Propellant Off-Load Only

	EO-09A	EO-07A	AS-05A	EO-57A
AKM	NM2*	TE-364-4	TE-364-3	TE-M-616
Propellant, kg (lb)	1636.1 (3607)	924.0 (2037)	500.0 (1102)	318.0 (701)
Percent of Off-Load	10	11	23	4
PKM	NM1*	NM1	NM2	NM2
Propellant, kg (lb)	5977.1 (13,177)	3721.8 (8215)	1814.8 (4001)	1261.0 (2780)
Percent of Off-Load	0.6	38	0	31

*New Motor 2 and New Motor 1

Table 3-7. Solid Motor Characteristics for Non-Geosynchronous Missions

	NM1	NM2	TE-364-4	TE-364-3	TE-M-616
Propellant Weights, kg (lb)	6012.9 (13,256)	1814.8 (4001)	1038.7 (2209)	653.2 (1440)	332.9 (734)
Motor Case Weight, kg (lb)	668.2 (1473)	201.8 (445)	83.0 (183)	64.9 (143)	29.5 (65)
Total Motor Weight, kg (lb)	6681.1 (14,729)	2016.7 (4446)	1121.8 (2473)	718.0 (1583)	362.4 (799)
Propellant I_{SP} , sec	292	292	286	290	293
Total Impulse, N-sec (lb-sec)	1.722×10^7 (3.871×10^6)	5.2×10^6 (1.168×10^6)	2.91×10^6 (654,400)	1.860×10^6 (418,100)	9.57×10^5 (215,200)
Thrust, N (lb)	143,448 (32,250)	61,138 (13,745)	68,499 (15,400)	43,146 (9700)	26,688 (6000)
Burn Time, sec	120	85	41	42	35
Propellant Mass Fraction	0.90	0.90	0.926	0.910	0.919

this early design phase. Notice that one way to reduce the amount of off-load of the PKM is to carry a fully loaded AKM and employ energy management techniques.

3.1.2.2 Error Analysis

In Table 3-6, it is seen that mission EO-07A requires 11 percent and 38 percent off-load of the AKM and PKM, respectively. Computer simulation of this mission for a minimum-energy and an excess-energy approach was achieved with the GTS program and its optimization operators UBEST and OPTIM. The minimum-energy case is equivalent to the propellant off-load percentages of Table 3-6. If the motors are assumed fully loaded, then the excess ΔV is 159.1 m/sec (552 ft/sec) and 781.6 m/sec (2563 ft/sec) for the AKM and PKM, respectively. Table 3-8 contains the solution parameters and observe that some rather large attitude angles are required to dissipate the excess energy. Also, the total mission time to synchronous altitude is reduced for this case. Included in Table 3-8 are the selected 3σ dispersions applicable to the mission parameters and the resulting 3σ (RSS) injection orbit errors. For this particular mission, the injection orbit is much more sensitive to the excess-energy case than to the minimum-energy case.

Another approach investigated during this brief error analysis study consisted of assuming errors in the PKM burn and then using UBEST to obtain the AKM burn conditions that given an injection orbit approaching the final orbit in a least-squares sense. Weighting factors are available and provide the flexibility to drive one orbit parameter (period, inclination, or eccentricity) arbitrarily close to the final desired value. This approach was used in both the minimum-energy and excess-energy cases of mission EO-07A previously described. The results appear in Table 3-9. An extremely "less likely" situation was assumed in the excess energy case where the $+3\sigma$ dispersion was applied to each parameter. A more probable condition is the 3σ variation on ΔV only, as was used in the minimum-energy case. However, these cases do establish the simulation tool for automatically

Table 3-8. Error Analysis for Geosynchronous Mission EO-07A

● Energy Management Solution for Non-Optimum Burns

- AKM/PKM: TE-364-4/NM1
- Park Orbit: 296.32 km (160 nmi) Circular/28.5 deg Inclination
- Minimum Energy Required: 1.779/2.451 km/sec (5841/8039 ft/sec), Off-Load: 11%/38%
- Energy Available: 1.938/3.232 km/sec (6360/10,605 ft/sec), Excess ΔV : 236.81/1163 m/sec (522/2563 ft/sec)

● Solution Parameters for Nominal Vehicle

● Minimum Energy

	Δ Pitch ^a (deg)	Δ Yaw ^a (deg)	Δ Coast Time (Hr:Min)
AKM	0	49.72	5:16
PKM	0	-9.13	0:31

● Excess Energy

AKM	-58	61	3:55
PKM	-22	-42	0:31

● Selected 3σ Dispersion Specifications

	Pitch (deg)	Yaw (deg)	Total Impulse (%)	Coast Time (sec)
AKM	1	1	0.75	5
PKM	2	2	0.75	5

● Injection Orbit Errors (3σ)

	ΔT (min)	Δi (deg)	Δe	Δ_{HA}^b km (nmi)	Δ_{HP}^b km (nmi)
● Minimum Energy	79	1.1	0.068	4444.8 (2400)	1666.8 (900)
● Excess Energy	280	1.5	0.161	6667.2 (3600)	10,186.0 (5500)

^aThese angles are measured positive above and to the right of the velocity vector when viewed looking forward.

^bThe sign of the input dispersion can cause these values to be interchanged for near circular orbits.

Table 3-9. Adjusted Apogee Burn for Geosynchronous Mission EO-07A

- Nominal Orbit: Period, $T = 1436$ min; Inclination, $i = 0^\circ$; Eccentricity, $e = 0$
- Least Squares Solution with Optimization Operator UBEST
- Energy Management, Excess $\Delta V_2/\Delta V_1$: 159.1/781.6 m/sec (522/2564 ft/sec)

	Case	Weighting Factors			Errors		
		CW_1	CW_2	CW_3	ΔT (min)	Δi (deg)	Δe
+3 σ PKM Non-Adjusted AKM Burn	1	-	-	-	619.0	1.6700	0.235
	2	0.010	1.0	1	1.4	0.0300	0.216
	3	0.010	1.0	10	52.0	0.7910	0.095
	4	0.010	1.0	15	79.0	0.9010	0.074
	5	0.010	1.5	60	240.0	0.5880	0.020
	6	0.001	10.0	1	93.0	0.0002	0.164
● Minimum Energy							
+3 σ ΔV_1 18.29	7	-	-	-	69.0	0.7040	0.059
m/sec (60 ft/sec)	8	0.010	1.0	10	69.0	0.2420	0.005
Non-Adjusted AKM Burn	9	0.010	1.0	25	68.0	0.2740	0.004

solving such a problem and confirm the ability to obtain at least one orbit parameter to a specified degree of accuracy. These adjusted apogee burn cases as well as the previously described cases all employ instantaneous motor burns and a Kepleran orbit package defined over a spherical earth.

3.1.2.3 Non-Geosynchronous Earth Orbit Missions

The non-geosynchronous earth orbit missions of the NASA mission model are given in Table 3-10. Driver missions were selected and analyzed for the ΔV requirements (Table 3-11). The launch azimuth and park orbit inclination assumed for the 296.32-km (160-nmi) circular park orbit are for direct launches of the STS from the Kennedy Space Center. Launch azimuth limits taken are 35 deg and 116 deg East of North. The ΔV values determined are near a minimum for each mission, since plane change split was utilized.

Specific results for each mission are given in Table 3-12. Again, use of energy management techniques can reduce or eliminate the large propellant off-load situations. Notice the introduction of a new motor for mission AP-07A. New motor No. 3 was actually designed by mission EO-56A which is given in Table 3-13. A three-burn solution is required by this mission in order to keep the ΔV magnitude balanced and thus control the size of the solid motors. The new solid motors introduced for these non-geosynchronous missions are given in Table 3-14.

Table 3-10. Non-Geosynchronous Earth Orbits

SSPD Code	Weight		Orbit (Circ)		Inclination (deg)	Stabilization
	kg	lb	km	nmi		
OP-06A*	238	525	1,500.0	810	28.5	3-Axis
AP-04A	679	1,497	937.5	506	90.0	3-Axis
EO-61A	791	1,744	907.7	490	99.1	3-Axis
OP-01A*	789	1,739	30,002.0	16,200	90.0	3-Axis
AP-01A*	963	2,122	259 × 3,510	140 × 1,895	90.6	Spin
AS-16A*	1,300	2,866	71,600.0	38,661	28.5	3-Axis
AP-05A	1,488	3,280	12,778.0	6,900	55.0	3-Axis
EO-12A	2,150	4,740	1,676 × 1,695	905 × 915	103.0	3-Axis
EO-56A*	2,285	5,077	1,676 × 1,695	905 × 915	103.0	3-Axis
AP-07A*	3,946	8,699	12,778.0	6,900	55.0	3-Axis
AP-02A	307	676	1,852 × 37,040	1,000 × 20,000	28.5	Spin

*Selected driver missions

Table 3-11. Non-Geosynchronous Earth Orbits Driver Missions

SSPD Code	Weight (lb)	Orbit (nmi)	Inclination (deg)	$\Delta V_1^{(1)}$ m/sec (ft/sec)	ΔV_2 m/sec (ft/sec)	ΔV_T m/sec (ft/sec)	LAZ/i ⁽²⁾ (deg)
OP-06A	238.1 (525)	1500 (810) Cir	28.5	313 (1028)	300 (986)	614 (2014)	90/28.5
OP-01A	788.8 (1739)	30,002 (16,200) Cir	90.0	2443 (7689)	1967 (6453)	4310 (14,142)	35/57
				2443 (7689)	2563 (8409)	4906 (16,098)	116/37.4
AP-01A	962.5 (2122)	259.3 × 3518.8 (140 × 1900)	90.6	787 (2583)	3075 (10,090)	3863 (12,673)	35/57
AS-16A	1300.0 (2866)	71,600 (38,661) Cir	28.5	2760 (9056)	1363 (4473)	4123 (13,529)	90/28.5
EO-56A	2302.9 (5077)	1694.6 (915) Cir	103.0	601 (1972)	4976 (16,328) ⁽³⁾	5578 (18,300)	35/57
AP-07A	3941.3 (8700)	12,778.8 (6900)	55.0	1683 (5523)	1282 (4206)	2966 (9730)	≈37/55

(1) Assumes 296.32-km (160-nmi) circular orbit

(2) LAZ/i = Launch azimuth/inclination angle of park orbit

(3) This ΔV is too large for practical motor size. Utilizing a three-burn approach to balance the ΔV magnitude yields:

$$\Delta V_1 = 1293 \text{ m/sec (4242 ft/sec)}$$

$$\Delta V_3 = 963 \text{ m/sec (3159 ft/sec)}$$

$$\Delta V_2 = 3044 \text{ m/sec (9988 ft/sec)}$$

$$\Delta V_T = 5.30 \text{ km/sec (17,389 ft/sec)}$$

For orbits of 296 × 5556 km (160 × 3000 nmi), 1667 × 5556 km (900 × 3000 ft/sec),
1667 km (900 nmi) circular

Table 3-12. Non-Geosynchronous Earth Orbit Missions, Motor Selection Based on Propellant Off-Load Only

	OP-06A	OP-01A	AP-01A	AS-16A	AP-07A
AKM	TE-M-516	TE-364-4	NM1	TE-364-4	NM1
Propellant, kg (lb)	29.03 (64)	934 (2059)	3254 (7173)	914 (2016)	2839 (6039)
Percent of Off-Load	13	10	46	12	54
PKM	SVM-3	NM1*	NM2*	NM1	NM3*
Propellant, kg (lb)	38.10 (84)	3336 (7354)	1722 (3796)	5168 (11,393)	7255 (15,995)
Percent of Off-Load	39	45	5	14	21
Orbit, km (nmi)	1500 (810)	30,002 (16,200)	259 × 3519 (140 × 1900)	71,600 (38,661)	12,779 (6900)
Inclination, deg	28.5	90	90.6	28.5	55

*New motors 1, 2, and 3. Adapter weights are included at 6 percent of the weight they must carry.

Table 3-13. Environmental Monitoring Satellite (EO-56A)

Mission

Orbit, km (nmi)	1676 × 1695 (905 × 915)
Inclination, deg	103
Weight, kg (lb)	2303 (5077)

Flight Profile, km (nmi)

296.32
(160) Cir

296.32 × 5556
(160 × 3000)

1667 × 5556
(900 × 3000)

1667
(900) Cir

$$\Delta i_1 = 5^\circ,$$

$$\Delta i_2 = 36^\circ,$$

$$\Delta i_3 = 5^\circ,$$

$$\Delta V_1 = 1292 \text{ m/sec}$$

(4242 ft/sec)

$$\Delta V_2 = 3044 \text{ m/sec}$$

(9988 ft/sec)

$$\Delta V_3 = 963 \text{ m/sec}$$

$$\Delta V_T = 5.30 \text{ km/sec}$$

(17,389 ft/sec)

Motor Selection

	Motor 1	Motor 2	Motor 3
	NM3	NM3	TE-364-4
Propellant, kg (lb)	8977 (19,791)	9084 (20,027)	1034 (2279)
Percent of Off-Load	2	1	0.5

Table 3-14. Solid Motor Characteristics

	NM3	TE-M-516	SVM-3
Propellant Weights, kg (lb)	9189 (20,258)	33.1 (73)	62.1 (137)
Motor Case Weight, kg (lb)	1021 (2251)	5.0 (11)	10.0 (22)
Total Motor Weight, kg (lb)	10,210 (22,509)	38.1 (84)	72.1 (159)
Propellant I_{SP} , sec	292	288	278
Total Impulse, N-sec (lb-sec)	2.631×10^7 (5.915×10^6)	93,630 (21,050)	169,540 (38,116)
Thrust, N (lb)	187,938 (42,250)	5782 (1300)	7562 (1700)
Burn Time, sec	140	16	24
Propellant Mass Fraction	0.90	0.869	0.865

3.1.2.4 Interplanetary Missions

Table 3-15 contains the planetary model. The missions are indicated in Figure 3-1 along with ΔV curves for selected motor stacks. In each case, an adapter weight of 6 percent of the weight it must carry was assumed between stages. Each motor was fully loaded with propellant so that off-load would move the curves in the direction of decreasing ΔV . Two missions are not captured by these motor combinations, and no effort was made to improve motor design in order to ensure capture. The stack of four motors represents approximately 24,947 kg (55,000 lb) of weight, so that any redesign must be careful not to exceed the 29,478-kg (65,000-lb) Orbiter bay payload limit.

Table 3-15. New Planetary Model

SSPD Code	Weight		ΔV	C3
	(lb)	(kg)	(fps)	km ² /sec ²
AP-08A	617	280	28,946	154.49
PL-31A	651	295	21,699	86.25
AP-06A	769	349	22,218	90.81
AP-03A	940	426	14,373	27.19
PL-22A	1052	477	27,694	142.0
PL-19A	1279	580	12,969	17.0
AS-02A	1312	595	9,435	-7.0
LU-01A	1850	839	10,221	-1.86
PL-13A	2425	1100	22,127	90.0
LU-03A	2469	1120	10,221	-1.86
PL-28A	2778	1260	11,973	10.0
LU-02A	3042	1380	10,221	-1.86
PL-14A	3109	1410	25,201	118.0
PL-12A	3968	1800	22,353	92.0
PL-20A	4718	2140	18,472	59.0
PL-32A	5798	2630	15,812	38.0
PL-33A	5968	2707	16,590	44.0
PL-29A	6658	3020	12,687	15.0
LU-04A	5875	2664	10,221	-1.86
PL-09A	7496	3400	14,213	26.0
PL-07A	8157	3700	12,403	13.0
PL-01A	11,023	5000	12,403	13.0

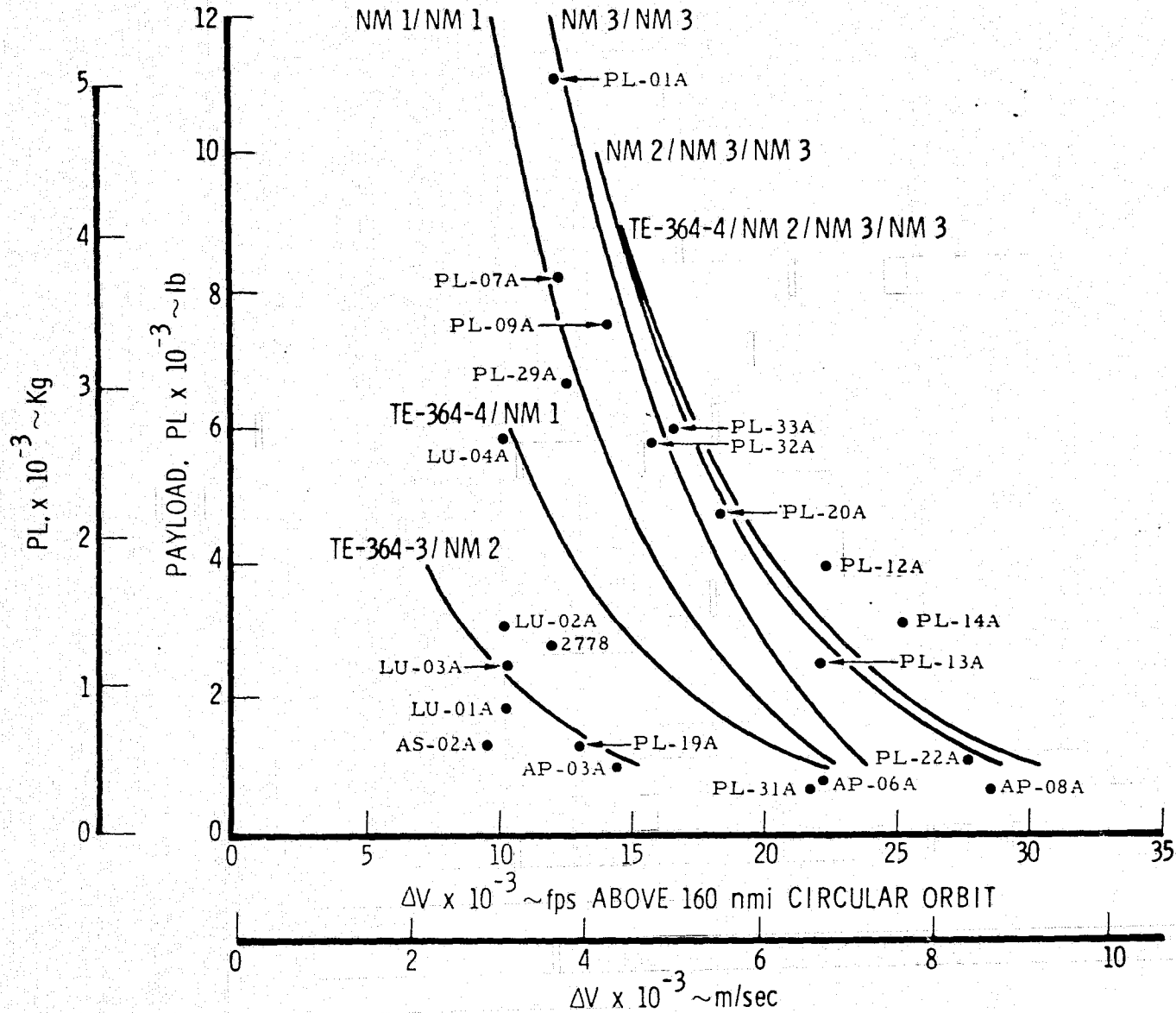

Figure 3-1. Planetary Missions Capture

3.1.3

Summary

The solid motors given in Tables 3-7 and 3-14 represent the family needed to capture the NASA mission model. Only three new motors are required containing propellant loads of 1814 kg (4000 lb), 6010 kg (13,250 lb), and 9185 kg (20,250 lb) for the specifications defined ($I_{SP} = 292$ sec and $M_f = 0.9$). Although propellant off-load is utilized here as the design procedure, the large off-loads can be reduced or eliminated through energy management techniques. Such techniques are defined here as non-optimum attitude alignment, non-direct launch azimuth, and non-optimum inclination changes. The non-optimum attitude alignment approach appears to increase orbit error sensitivity, but further analysis may indicate a way to use this excess energy to reduce the errors. The simulation tools used in the adjusted apogee burn procedure can be extended to minimize the error ellipse rather than the ΔV . Transfer time could also be minimized if desired. A further refinement of this concept would be to minimize the spacecraft propellant required to correct the injection orbit to the desired orbit.

The non-geosynchronous earth orbit missions are captured with the same motor family with the exception of EO-56A and AP-07A. Because of the high inclination of the EO-56A mission, a three-burn solution is required and the 9185-kg (20,250-lb) (propellant) motor was designed to capture this mission. Some sizeable off-loads are required for these missions, but adjustments to the launch azimuth and/or inclination change split can alleviate this condition. It is interesting to note that a WTR launch for mission EO-56A requires $\Delta V_1 = 358.23$ m/sec (1175 ft/sec), $\Delta V_2 = 341.36$ m/sec (1120 ft/sec), and $\Delta V_T = 699.48$ m/sec (2295 ft/sec) which corresponds to the 5.3 km/sec (17,390 ft/sec) required for the KSC launch.

Using two- and three-motor stacks from the previously defined motor family permits capture of all but two of the planetary missions. These missions are orbital spacecraft about Jupiter and Saturn, and no attempt was made to resize motors to capture these missions. An increased propellant load, increased I_{SP} , and improved mass fraction are all options for investigation in an effort to capture these two missions.

3.2

SOLID ROCKET MOTORS

The motors studied include five production units. The Thiokol (Elkton Division) TE-M-364-3, TE-M-364-4, TE-M-616, and TE-M-516 and the Aerojet SVM-3, whose characteristics are shown in Table 3-16. These new motors, one containing 3696 lb of propellant, one 13,256 lb, and the third 20,250 lb, are scaled-down versions of two Burner II IUS motors. The two new motors will utilize advanced technology as developed and demonstrated in the C-4 and MX programs; that is, they will make use of Kevlar-49 cases, EPDM insulation, 88-HTPB propellant, and carbon/carbon nozzles. The status of this technology is presented below and shown in Table 3-17.

3.2.1

Motor Cases

Kevlar (PRD-49) is an organic polymeric fiber with an average strand tensile strength of 547 ksi and a modulus of 20.3×10^6 psi. The fiber has a density of 0.052 lb/in.³, resulting in an average strand specific strength and modulus 1.7 and 2.8 times greater than the respective properties of high strength S-901 glass. The weight decrease resulting from the use of Kevlar in lieu of fiber glass is about 36 percent. Kevlar cases are being used for all three stages of the C-4 program. Kevlar vessels with diameters up to 74 in. have been fabricated and tested.

3.2.2

Case Insulation

The motor case internal insulation material is asbestos-loaded EPDM (ethylene propylene dimethyl monomer) rubber. The insulator is fabricated by hand layup followed by autoclave cure. EPDM has a density of 0.86 to 0.96 g/cc and will result in a weight saving of about 39 percent, as compared with the more commonly used asbestos-filled Buna-N rubber. Its ablation performance was proven in plasma arc tests to be equal to or better than that of the standard nitrile materials. Its compatibility with HTPB propellants and Kevlar cases has been demonstrated in the C-4 third stage development program.

Table 3-16. Solid Rocket Motor Characteristics

	I_T vac, lb-sec	T_B , sec	F_{vac} , lb	Dimensions D × L, in.	Propellant Weight, lb	Mass Fraction	I_{sp} (vac) sec	Nozzle Expansion Ratio
TE-M-364-3	418,100	42.0	9,700	36.8 × 52	1440.0	0.910	290.3	53
TE-M-364-4	654,400	41.4	15,400	36.8 × 66.25	2290.0	0.926	285.8	53
TE-M-616	215,200	34.9	6,000	27.3 × 48.7	734.2	0.919	291.0	42
TE-M-516	21,050	15.5	1,300	13 × 22.8	73.0	0.869	288.0	60
SVM-3	38,116	24.0	1,700	18 × 24	137.2	0.865	277.5	45

Table 3-17. New Motors No. 1, No. 2, and No. 3 Motor Characteristics

	I_T vac, lb-sec	T_B , sec	F_{vac} , lb	Dimensions D × L, in.	Propellant Weight, lb	Mass Fraction	ISP (vac) sec	Nozzle Expansion Ratio
New Motor No. 1	3.871×10^6	120	32,250	80 × 82	13,250	0.930	291.8 or 300.8	41 or 86
New Motor No. 2	1.162×10^6	100	12,000	57 × 76	4000	0.917	300.8	100
New Motor No. 3	5.915×10^6	140	42,000 or 43,400	91 × 92	20,250	0.939	291.8 or 300.8	41 or 86

3.2.3

Propellant

The HTPB (hydroxy-terminated polybutadiene) propellant is structurally similar to the more common CTPB (carboxy-terminated polybutadiene) propellant, the main difference being that the reacting group is hydroxyl instead of carboxyl. The superiority of HTPB over CTPB lies in lower viscosities (50-150 versus 100-300 poise) which allow higher solids loadings, more diversified cures, and better aging. At the 88 percent solids loading (18 percent aluminum, 70 percent ammonium perchlorate, and 12 percent binder), this propellant has a theoretical specific impulse of 264.3 sec, a density of 0.0648 lb/in.³, a burning rate at 1000 psia of as low as 0.255 in. per second, a flame temperature of 6,387°F, and a characteristic velocity of 5200 ft/sec.

This family of propellants has been under development since 1962 by all major contractors. Thus far, about 400,000 lb of HTPB propellant have been processed. The Sam-D, an operational 600-lb motor, has contained 88 percent HTPB since 1970. The 90-percent HTPB propellant is currently under advanced development for the MX first stage.

3.2.4

Nozzle

The baseline nozzle will be fixed and submerged by 35 percent and will make use of state-of-the-art composite materials for the entrance section (silica phenolic), the exit cone (carbon phenolic), and the throat (pyrolytic graphite washers encased in Graphitite G-90). A more advanced design will utilize carbon/carbon materials in the entrance and exit cone but retain the pyrolytic graphite at the throat for minimization of erosion.

The carbon/carbon materials consist of a fabric or other reinforcement materials which have been carbonized or graphitized and are bound together by a carbon or graphite matrix. Typical processing temperatures are in the 4000°F to 5000°F range. Work on carbon/carbon nozzles is being done by all of the major solid motor contractors. Nozzles with throats from 4 in. to 10 in. in diameter and exit cones up to 30 in. have

been tested with no problems attributable to these materials. Operating pressures ranged from 500-1200 psia and operating times up to 70 sec. Most of the work is being done for the MX and C-4 programs. The major advantage of carbon/carbon nozzles is light weight (about 40 percent decrease over conventional design), high erosion resistance, absence of char, and a smoothly eroded surface resulting in a nozzle efficiency increase of about one percent. Presently, the cost of the carbon/carbon parts is 4 to 5 times higher than that of the carbon composites.

3.2.5 Igniter

The ignition system will consist of a remotely located safe-and-arm device, a through bulkhead initiator (TBI), and a pyrogen igniter. The initiators will be 1 amp/1 Watt nofire, and they will function in less than 4 msec with 4.5 amperes applied. Although one initiator is sufficient to initiate the ignition sequence, two will be provided for redundancy. The pyrogen igniter consists of Boron Potassium Nitrate (BPN) pellets and a case-bonded, centrally perforated composite propellant grain. They are contained in a steel case designed to remain intact during motor operation and be attachable to the forward dome of the motor. This igniter design is state of the art.

3.2.6 Spin Balancing and Spin Testing Facility

Spin balancing facilities, essentially a spin table, exist at Philco-Ford for empty cases and post-fired motors. Facilities for loaded motors exist at the WTR, ETR, and Wallops Island. Only the latter can handle motors of up to 20,000 lb and up to a diameter of 90 in. This is their limit, and it is the only facility where motors of this size can be handled.

At present, there is no facility capable of spin-test firing a 20,000-, or even a 15,000-lb motor. The largest motor spin-tested at Arnold Engineering and Development Center (AEDC) weighed under 3,000 lb (TE-M-364-4). Assuming component availability, construction of a fixture capable of handling a 15,000-20,000-lb motor would cost about \$100,000.

A motor of this size can be accommodated in the AEDC J-5 cell. Table 3-18 lists the present facilities.

Table 3-18. Spin Rocket Test Facilities

Facility Name	AFRPL	AEDC	
	Horizontal Attitude Facility	T-3	J-5
Capabilities			
Thrust, lb	20,000	25,000	100,000
Diameter, in.	45	50	80
Spin Rate, rpm	180	1200	--
Motor Weight, lb	--	5000	--

3.2.7 Motor Off-Loading

Motor off-loading can be accomplished by incomplete motor casting, by the use of a larger diameter mandrel, or by trimming and removal of the propellant after casting and cure. Motors presently off-loaded include the TE-M-616 (will fly off-loaded 6-20 percent), the TE-M-364-4 (has flown off-loaded 6 percent), and the FW-5 (tested at 10 percent off-loading).

If properly carried out, the effect on the thrust-time curve of off-loading by the use of a large mandrel or propellant trimming will be simply the omission of its initial position, that which corresponds to the burning of the missing propellant. Therefore, using these methods, off-loading can approach 100 percent.

The parameters primarily affected by off-loading are the total impulse and the ignition transient. Since the motor total impulse is the product of the specific impulse and the motor weight, it will be reduced

in proportion to the missing propellant weight alone, since the effect on the specific impulse will be insignificant. The effect on the ignition transient can be significant if the off-loading exceeds five percent, and redesign of the igniter may become necessary. A reevaluation of the ignition system is always advisable when a motor is to be off-loaded.

Additional qualification testing for off-loaded motors will depend upon the degree of off-load, the number of different off-loads, and the procedures used. Assuming off-loading by the use of a larger mandrel or by trimming, a minimum of two off-loaded motors should be tested at altitude, one at the high and the other at the low specified temperature following environment testing.

3.2.8 Spin Stability Considerations

The presence of a rotational torque in solid rocket motors during burning contributes to an increase in spin rate proportional to the reciprocal of the inertia. Nozzle construction seems to affect the induced roll torque, as indicated by the use of the TE-M-364-2 motor in Boeing's Burner II/IIA three-axis stabilized stage. The roll torques on early motors were random in direction and were 1 ft-lb or less, whereas in subsequent motors with rosette layup nozzles, the roll torques were consistently clockwise and their maximum value was 2 ft-lb. An increase of the roll torque with time was also observed. The technical impact of increased spin is small, particularly if recognized beforehand. The impact would be greater on spin, despin, three-axis stabilized than on spin-stabilized spacecraft. The amount of impulse required to negate the additional spin is small and can be provided by the spacecraft's roll thrusters. The spacecraft should be qualified to the maximum expected spin rate.

3.2.9 Thrust Alignment

Specifications have required that the nozzle axis and motor axis be parallel within 0.002 to 0.11 deg and that the center of the throat be within 0.03 in. (or less) of the motor centerline. The language used in the

motor specification is more exact, but the intent is the same. The maximum lateral thrust may also be specified at about 0.002 deg of the nominal maximum axial thrust. It is presumed the lateral force acts at the nozzle exit plane. There is no information that this value can be related to that for nozzle alignment. Therefore, further reducing the nozzle misalignment will not necessarily reduce the maximum lateral thrust. This statement is based on data from unpressurized motors with metallic cases. The lateral thrust measurements during subsequent firings showed no agreement in either magnitude or direction with the nozzle alignment values previously measured. A small amount of data for pressurized fiberglass case motors shows somewhat larger nozzle misalignments than the unpressurized metallic cases and a slightly larger lateral thrust. There are no similar data for Kevlar cases. The total lateral impulse has been occasionally specified at a value that indicates the average lateral thrust to be between 30 and 75 percent of the maximum lateral thrust. The lower values appear unrealistic, but 50 percent appears to be reasonable. Table 3-19 shows motor error source data.

The specification of maximum lateral force as 0.002 deg of the axial thrust is based on measurements of spinning motors at AEDC. Data from Boeing Aircraft Co. Burner II/IIA flights (three-axis stabilized) show maximum lateral forces approximately one-fourth of that value. Whether the differences can be attributed to a spinning versus a non-spinning environment or to the difficulty of measuring the low values of lateral thrust in a ground test is unknown.

The lateral thrust determines the attitude control requirements for three-axis stabilized spacecraft and the angular insertion error for spin-stabilized spacecraft. The total lateral impulse is primarily important for short life spacecraft or those with cold gas ACS where the control requirements during solid motor burn are a sizeable fraction of the total control requirements. The lateral thrust is not the only disturbing torque; there are also those due to errors in knowing the spacecraft c. g. and the installation errors. The contribution of the motor lateral thrust

Table 3-19. TE-M-364 Motor Error Source Data

Motor Designation TE-M-364	Static Balance Lateral CG (in.)				Alignment of Nozzle Centerline with Motor Centerline			
	Empty		Loaded		Angular (Radian)		Radial (in.)	
	Req'd	Avg Del	Req'd	Avg Del	Req'd	Avg Del	Req'd	Avg Del
-1	≤0.005	0.003	≤0.030	0.006	≤0.00035	0.00012	≤0.007	0.004
-2	≤0.005	0.003	≤0.030	0.005	≤0.00035	0.00011	≤0.007	0.004
-3 and -14	≤0.017	0.004	≤0.017	0.007	≤0.00035	0.00014	≤0.007	0.004
-4, -11, and -18	≤0.017	0.002	≤0.017	0.004	≤0.00035	0.00016	≤0.007	0.003
-15	≤0.010	0.001	≤0.017	0.004	≤0.00035	0.00014	≤0.007	0.001

Dynamic Balance, lb-in.²

	Empty		Loaded	
	Req'd	Avg Del	Req'd	Avg Del
-19	5	0.0	30	4.8

Total Impulse Reproducibility (3σ across temperature range)

	Contracted, %	Achieved, %
-1	±1.00	0.63
-2	±0.60	0.58
-18	±0.75	0.40
-3	±0.75	0.58
-4	±0.75	0.40

to the total disturbance torque has ranged from 25 to 95 percent, depending upon effort expended in minimizing the other sources of torque. One must not add the nozzle misalignment or offset into the error calculation as they are already included in the lateral thrust. A spin-stabilized spacecraft will have an insertion error angle caused by the disturbing torques. The value is time-dependent but can be approximated by

$$\text{Error Angle} = T/Iw^2$$

where I is the moment of inertia about the spin axis, w is the spin rate, and T is the lateral torque. Current spacecraft have an error of about 0.5 deg.

3.2.10 Center of Gravity and Balance

Static imbalance is the weight times the radial deviation of the c.g. from the geometric roll axis. The geometric roll axis is perpendicular to, and through the center of, the motor attach plane. Thus, the radial c.g. tolerance can be specified instead of the static imbalance. Dynamic imbalance is the measurement of the inertia cross product I_{xy} , where x is the roll axis and y is either the pitch or yaw axis. Theoretically, I_{xy} is zero for any radially symmetric body. The measurement is made in a dynamic balancing machine. The dynamic imbalance determines the angle θ between the actual roll axis and the geometric axis, and for small angles

$$\theta = \frac{I_{xy}}{I_{xx} - I_{yy}}$$

For spherical motors where I_{xx} and I_{yy} are similar, θ will be larger than for motors with larger length-to-diameter ratios.

The static and dynamic imbalance are more important than specification of the tolerance of the c.g. along the thrust axis. Static imbalance causes disturbance torques, and dynamic imbalance causes wobble. The tolerance on the c.g. along the roll (thrust) axis for a loaded motor is

typically ± 0.3 in., but larger values have been used. Smaller values have been used for the empty motor. The axial location of the c. g. is estimated during motor design. For spin-stabilized spacecraft, the spacecraft and motor c. g. have been close, and it is easy to keep $I_{xx}/I_{yy} = 1.1$ that way. This is to prevent the spacecraft from nutating to spin about the axis of maximum inertia. However, current spacecraft do not typically have flexible appendages that would allow the easy transfer of momentum between axes; therefore, one could probably fly a spacecraft with an unfavorable moment of inertia ratio prior to solid motor burn. Larger length/diameter motors are not used because of the difficulty in having $I_{xx} = I_{yy}$. It is easier to eliminate the error source than to estimate its value.

Specifications of the empty motor really serve no technical requirement. Only the loaded motor and burned-out motor requirements are of importance. Specifying imbalance of the empty motor is more of a quality control requirement in that the burned-out motor will more likely have minimum imbalance. For empty motors, specification of static imbalance has been from 0.01 to 0.03 in., and dynamic imbalance has been from 0.0005 to 0.006 rad. Balance is achieved either with weights on the outside of the case or with insulation or weights on the inside of the case.

Loaded motors are normally balanced by trimming propellant. One can also add insulation strips on aft propellant faces where they will not appreciably affect burning symmetry. Early motors had static imbalance of about 0.02 in., but more recently the requirements have been from 0.01 to 0.005 in. Dynamic imbalance has ranged from 0.001 to 0.01 rad. There is no problem in achieving low values; it is only dependent upon the sensitivity of the dynamic balancer and the time allowed.

Specifications of the burned out motor imbalance have only been used recently. There is very little data on burned out motors. Prior to the measurements, the insulation that is not attached was carefully removed. The assumption, considered to be conservative, is made that this insulation was evenly distributed. The safe and arm, usually asymmetric, is also removed. One measurement on one motor gave $\theta = 0.008$ rad. Three measurements on a larger motor were all less than 0.002 rad. The static imbalances were 0.09 and 0.0009 in., respectively.

3.3 ANGULAR MOTION OF THE SSUS DURING PKM/AKM BURN

3.3.1 Introduction

The attitude motion of the SSUS during perigee or apogee burn, in particular, the heading error from the desired perigee/apogee direction is necessary for orbital accuracy studies. Simplified equations previously used to estimate heading error have been viewed with distrust; therefore, a simulation was derived to attain the attitude motion.

For the reference payloads for SSUS, the simulation was run and the results are shown. The payloads are EO-09A, EO-07A, AS-05A, and EO-57A, and all payloads except the EO-57A were spun at the maximum rate permissible of 45 rpm. Payload EO-57A is already a spin-stabilized satellite that spins at 100 rpm. The mass properties, thrust, and c.g. of these payloads are shown in Figures 3-2 through 3-5.

3.3.2 Simulation

The equations simulated are:

$$\dot{\omega}_1 = 0$$

$$\dot{\omega}_2 = \frac{T_y}{I_z} - \frac{(I_x - I_z)}{I_z} \omega_3 \omega_1$$

$$\dot{\omega}_3 = \frac{T_z}{I_z} - \frac{(I_y - I_x)}{I_z} \omega_1 \omega_2$$

where ω_1 , ω_2 , and ω_3 are the orthogonal body rates. The inertias I_x , I_y , and I_z are assumed to be linearly decreasing from the initial to final value. Similarly, the torque components T_x and T_y are linearly increasing as the c.g. moves forward. The value of thrust vector misalignment used was 0.002 rad. (0.11459 deg).

PAYLOAD EO-57A	INITIAL CONFIGURATION	MOTOR 1 BURN OUT	JETTISON MOTOR 1 AND ADAPTER	MOTOR 2 BURN OUT	JETTISON MOTOR 2 AND ADAPTER
WEIGHT, lb	4,640.0	1,974.0	1,580.0	840.0	680.0
LENGTH FROM NOSE, ft	22.0	22.0	15.5	15.5	10.0
I_R , slug-ft ²	230.0	155.0	105.0	90.0	80.0
I_T , slug-ft ²	3,830.0	1,770.0	995.0	350.0	80.0
C. M. FROM NOSE, ft	14.9	10.7	8.9	5.5	--
C. M. FROM GIMBAL, ft	7.1	11.3	6.6	10.0	--
THRUST, lb	13,150.0	13,150.0	6,000.0	6,000.0	--

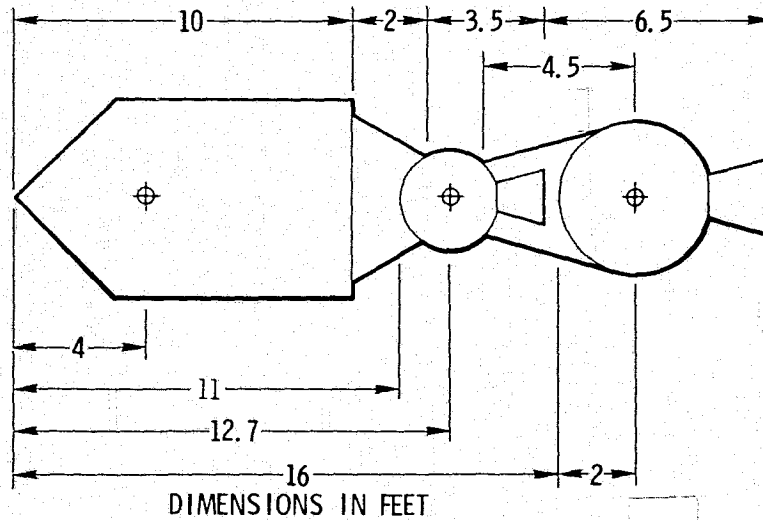

Figure 3-2. EO-57A Payload

PAYLOAD AS-05A	INITIAL CONFIGURATION	MOTOR 1 BURN OUT	JETTISON MOTOR 1 AND ADAPTER	MOTOR 2 BURN OUT	JETTISON MOTOR 2 AND ADAPTER
WEIGHT, lb	6,920.0	2,930.0	2,360.0	1,250.0	1,070.0
LENGTH FROM NOSE, ft	20.0	20.0	13.0	13.0	8.0
I_R , slug-ft ²	880.0	260.0	200.0	160.0	150.0
I_T , slug-ft ²	5,060.0	2,060.0	1,150.0	440.0	230.0
C. M. FROM NOSE, ft	13.1	9.3	7.8	4.9	4.0
C. M. FROM GIMBAL, ft	6.9	10.7	5.2	8.1	--
THRUST, lb	13,150.0	13,150.0	9,700.0	9,700.0	--

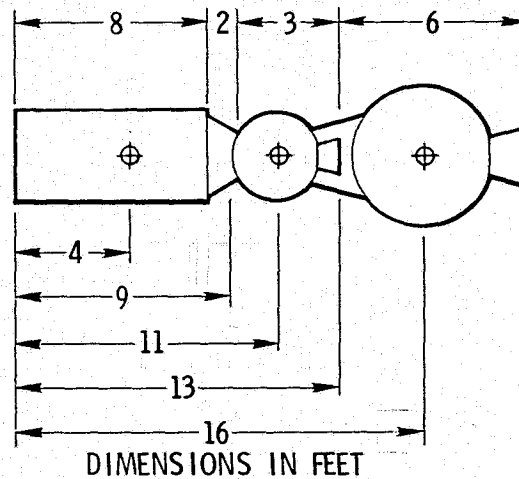

Figure 3-3. AS-05A Payload

PAYLOAD EO-09A	INITIAL CONFIGURATION	MOTOR 1 BURN OUT	JETTISON MOTOR 1 AND ADAPTER	MOTOR 2 BURN OUT	JETTISON MOTOR 2 AND ADAPTER
WEIGHT, lb	23,050.0	9,800.0	7,850.0	4,150.0	3,570.0
LENGTH FROM NOSE, ft	31.0	31.0	23.0	23.0	17.0
I_R , slug-ft ²	4,200.0	2,600.0	2,210.0	1,870.0	1,760.0
I_T , slug-ft ²	27,400.0	13,890.0	9,110.0	5,060.0	3,800.0
C.M. FROM NOSE, ft	22.5	17.7	15.9	12.2	11.0
C.M. FROM GIMBAL, ft	8.5	13.3	7.1	10.8	--
THRUST, lb	32,250.0	32,250.0	13,150.0	13,150.0	--

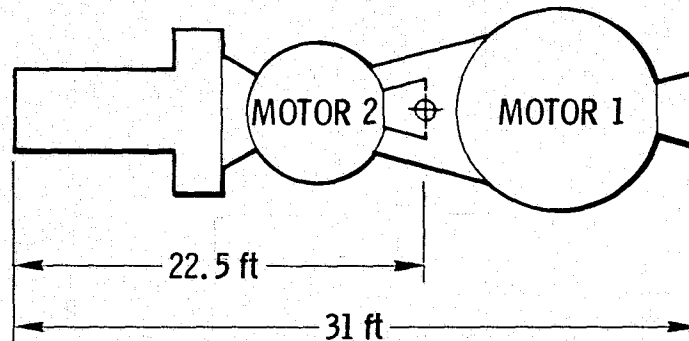

Figure 3-4. EO-09A Payload

PAYLOAD EO-07A	INITIAL CONFIGURATION	MOTOR 1 BURN OUT	JETTISON MOTOR 1 AND ADAPTER	MOTOR 2 BURN OUT	JETTISON MOTOR 2 AND ADAPTER
WEIGHT, lb	13,045.0	5,545.0	4,445.0	2,345.0	2,015.0
LENGTH FROM NOSE, ft	19.0	19.0	11.0	11.0	3.0
I_R , slug-ft ²	2,200.0	1,280.0	1,010.0	860.0	810.0
I_T , slug-ft ²	10,600.0	4,300.0	2,100.0	810.0	470.0
C. M. FROM NOSE, ft	10.9	6.6	5.0	2.3	1.5
C. M. FROM GIMBAL, ft	8.1	12.4	6.0	8.7	--
THRUST, lb	32,250.0	32,250.0	15,400.0	15,400.0	--

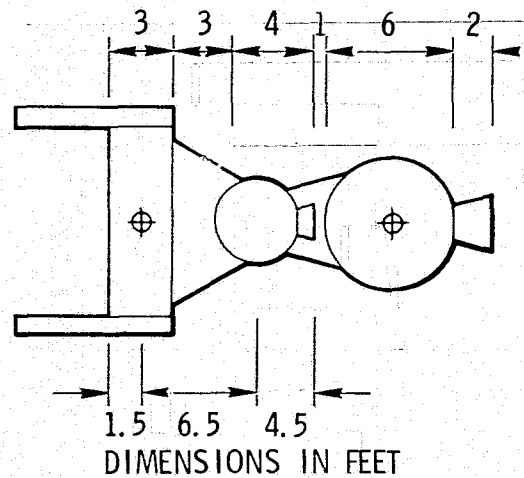

Figure 3-5. EO-07A Payload

The Euler angles relating the body to inertial space are taken in the order of yaw, pitch, and roll. Therefore, the Euler rates are:

$$\dot{\psi} = \frac{\omega_2 \sin \phi + \omega_3 \cos \phi}{\cos \theta}$$

$$\dot{\theta} = \omega_2 \cos \phi - \omega_3 \sin \phi$$

$$\dot{\phi} = \omega_1 + \tan \theta (\omega_2 \sin \phi + \omega_3 \cos \phi)$$

To obtain the heading error from the desired direction, the acceleration along the inertial axes is integrated and the angle computed as the arc tangent of transverse velocity to longitudinal velocity. The acceleration in inertial space may be expressed as:

$$a_x = \frac{T}{m} \cos \theta \cos \psi$$

$$a_y = \frac{T}{m} \cos \theta \sin \psi$$

$$a_z = \frac{-T}{m} \sin \theta$$

where the thrust T is constant, and the mass m is linearly decreasing from the initial to the final value.

There is an additional effect during the burn called jet damping. This term is difficult to estimate but only effects nutation. Since heading error is of prime interest and jet damping only decreases nutation, this study is then conservative for nutation effects. Further, an active nutation damper is in effect during the coasting periods between perigee and apogee burn, thereby reducing the initial nutation error prior to AKM burn to a low value.

3.3.3 Results

Table 3-20 lists the attitude or heading error for the various payloads for perigee and apogee insertion. In addition, the simplified equation generally used has been verified as long as the initial values of inertia and torque are used; i. e.,

$$\theta = \frac{T}{I_R \omega_S^2}$$

where

- θ = the heading error in rad.,
- T = the torque in ft-lb,
- I_R = the roll or spin inertia in ft-lb-sec², and
- ω_S = the spin rate in rad/sec.

Table 3-20. Heading Error Due to Motor Burn ($\delta = 0.002$ rad)

Payload		Incremental Error
EO-09A	PKM Burn	0.337°
	AKM Burn	0.230°
AS-05A	PKM Burn	0.742°
	AKM Burn	1.322°
EO-07A	PKM Burn	0.602°
	AKM Burn*	0.48°
EO-57A	PKM Burn	0.450°
	AKM Burn	0.393°

* Transverse Inertia increased to 910 ft-lb-sec² to avoid region of equal inertias. If roll inertia equals transverse inertia, there is no spin stabilization, and the vehicle pitches over. With the values used, the end of AKM burn is becoming marginally stable. Coning up to 10 degrees was encountered. While not an accuracy problem since the coning at these amplitudes was short lived, the sizing of the active nutation control is affected.

It should be emphasized that the heading error for these cases is only the error accrued during the burn. Due to shutdown of the solid motor, the heading error and the nutation are increased (in an RSS sense). However, in the SSUS concept, the heading error will be reduced before AKM firing by using an attitude determination program on the ground in conjunction with spacecraft sensors. The spacecraft will be torqued in the correct firing direction for the AKM. In addition, an active nutation damper will reduce any nutation during coast to a tolerable level.

Figures 3-6 through 3-11 are typical of the results obtained. The curves represent a 10-sec burn of the AS-05A apogee kick motor. The body rates are shown in Figures 3-6 and 3-7 and cross plotted in Figure 3-8. Note that the mean of the yaw rate is increasing with time. This effect is due to the torque increasing as the c.g. moves forward due to the propellant burn. The Euler angles, Theta and Psi, are shown in Figures 3-9 and 3-10 and cross plotted in Figure 3-11. This last plot may be thought of as representing the nose of the spacecraft moving with respect to inertial space. The motion can be broken down into an offset and two sinusoids of different frequencies forming a curve called an epicycloid. It may also be described as a point on the circumference of a circle which rolls along the outside of an offset fixed circle of another diameter. The two frequencies for this example are:

$$\Omega_1 = \frac{(I_T - I_R) \omega_S}{I_T} = 223 \text{ deg/sec}$$

$$\Omega_2 = \frac{I_R}{I_T} \omega_S = 46.96 \text{ deg/sec}$$

where

Ω_2 = the precessional rate as seen in inertial coordinates

Ω_1 = the apparent spin rate in inertial coordinates.

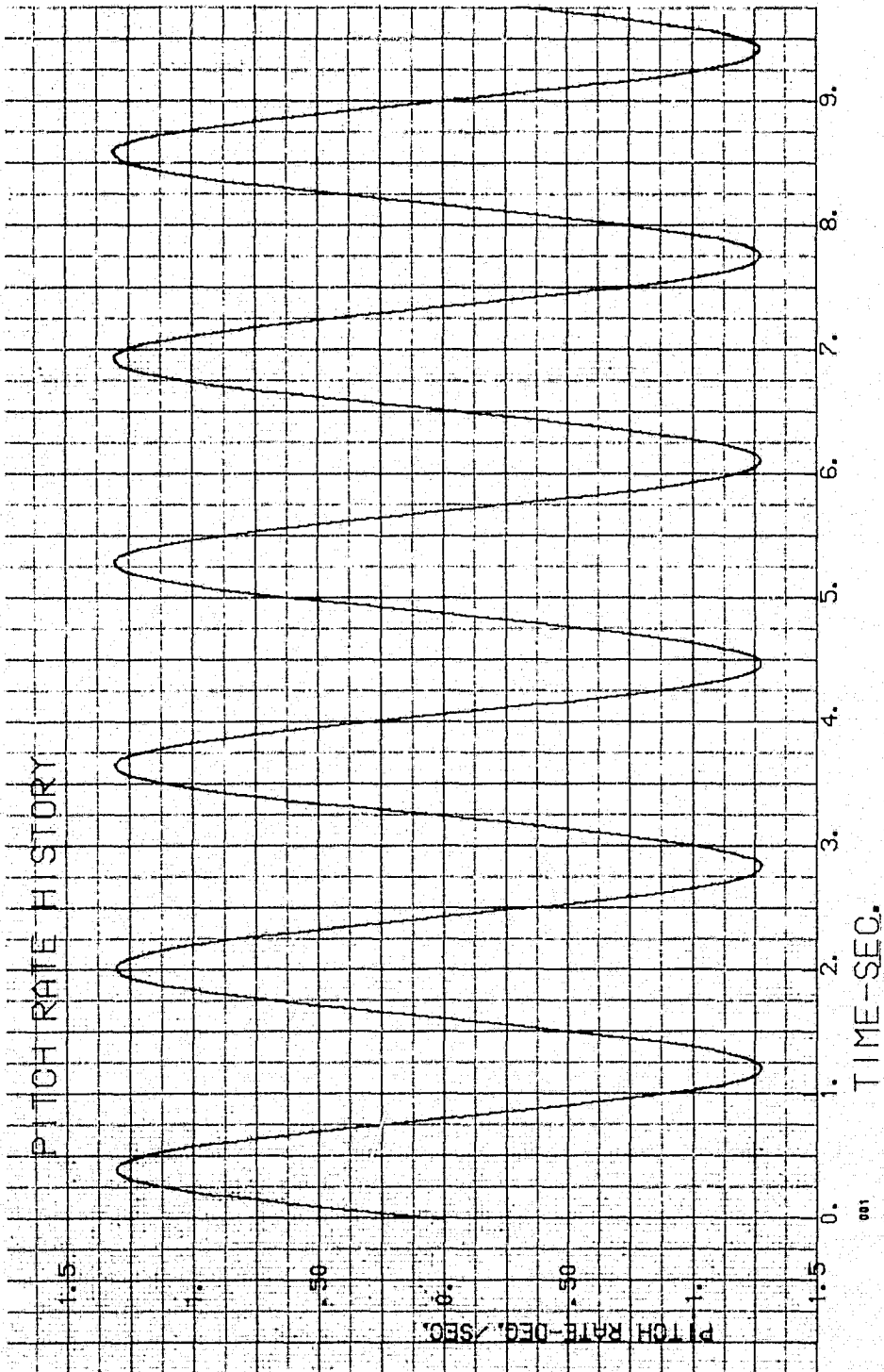

Figure 3-6. Pitch Rate History

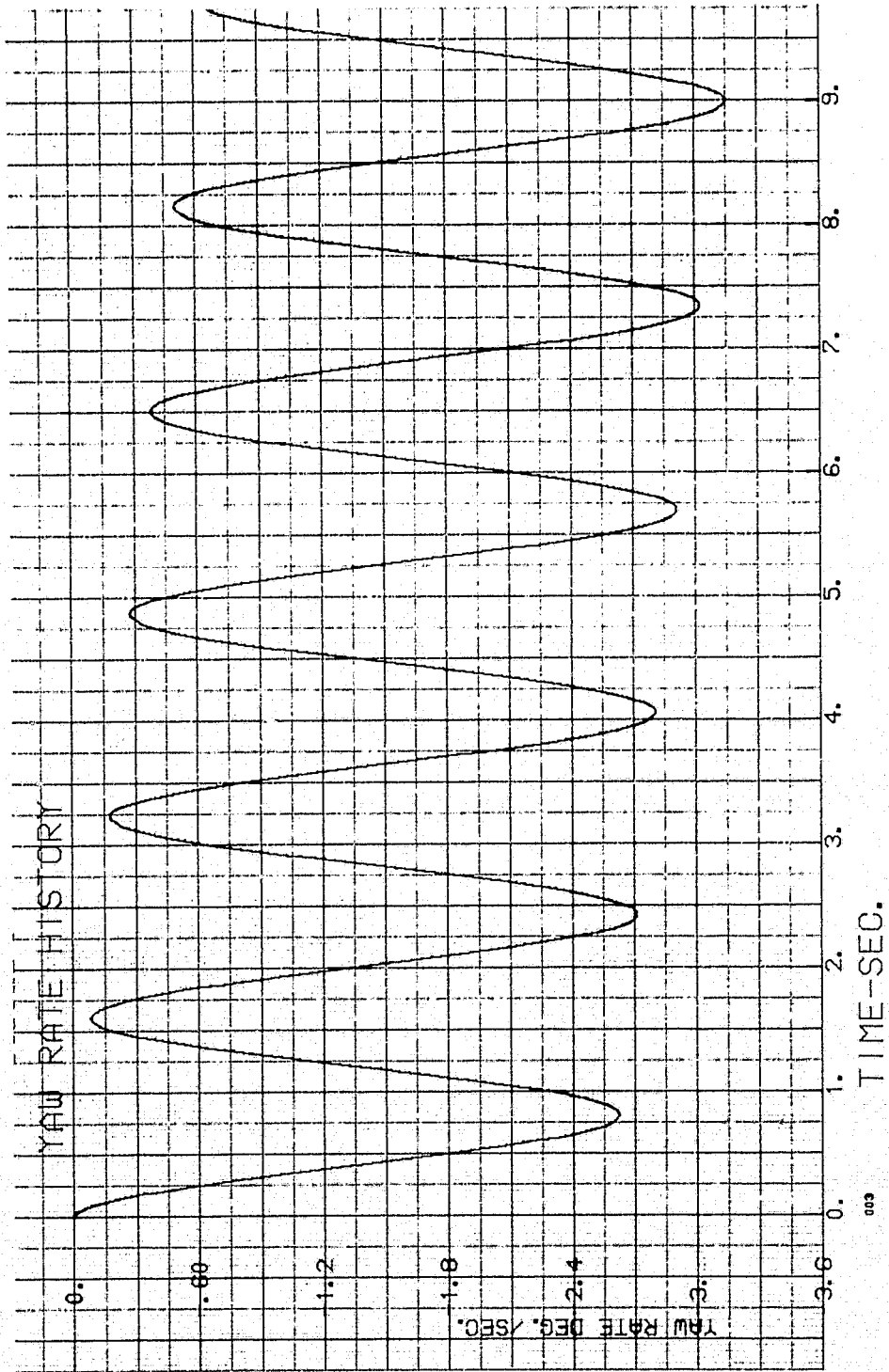

Figure 3-7. Yaw Rate History

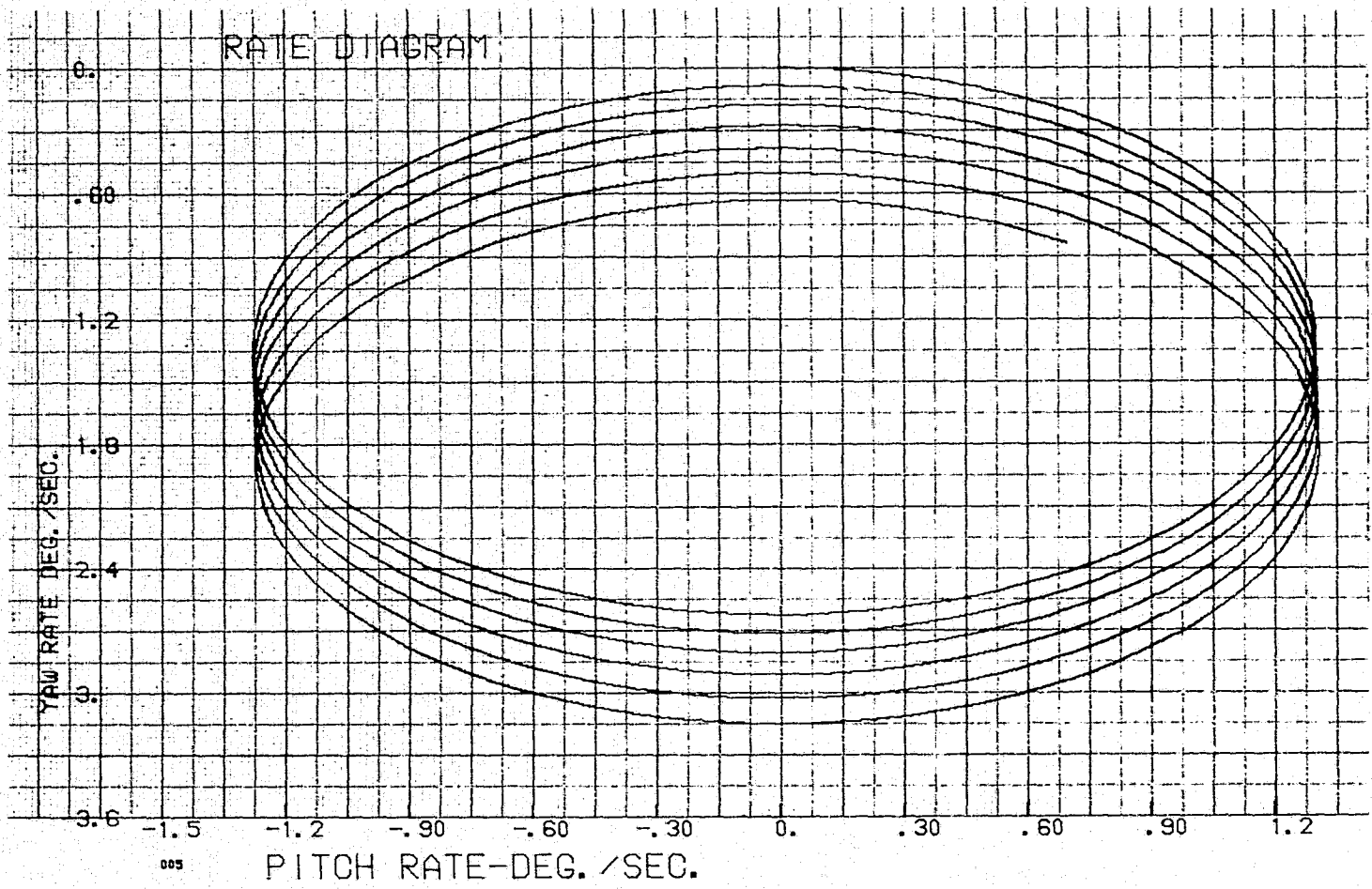

Figure 3-8. Rate Diagram

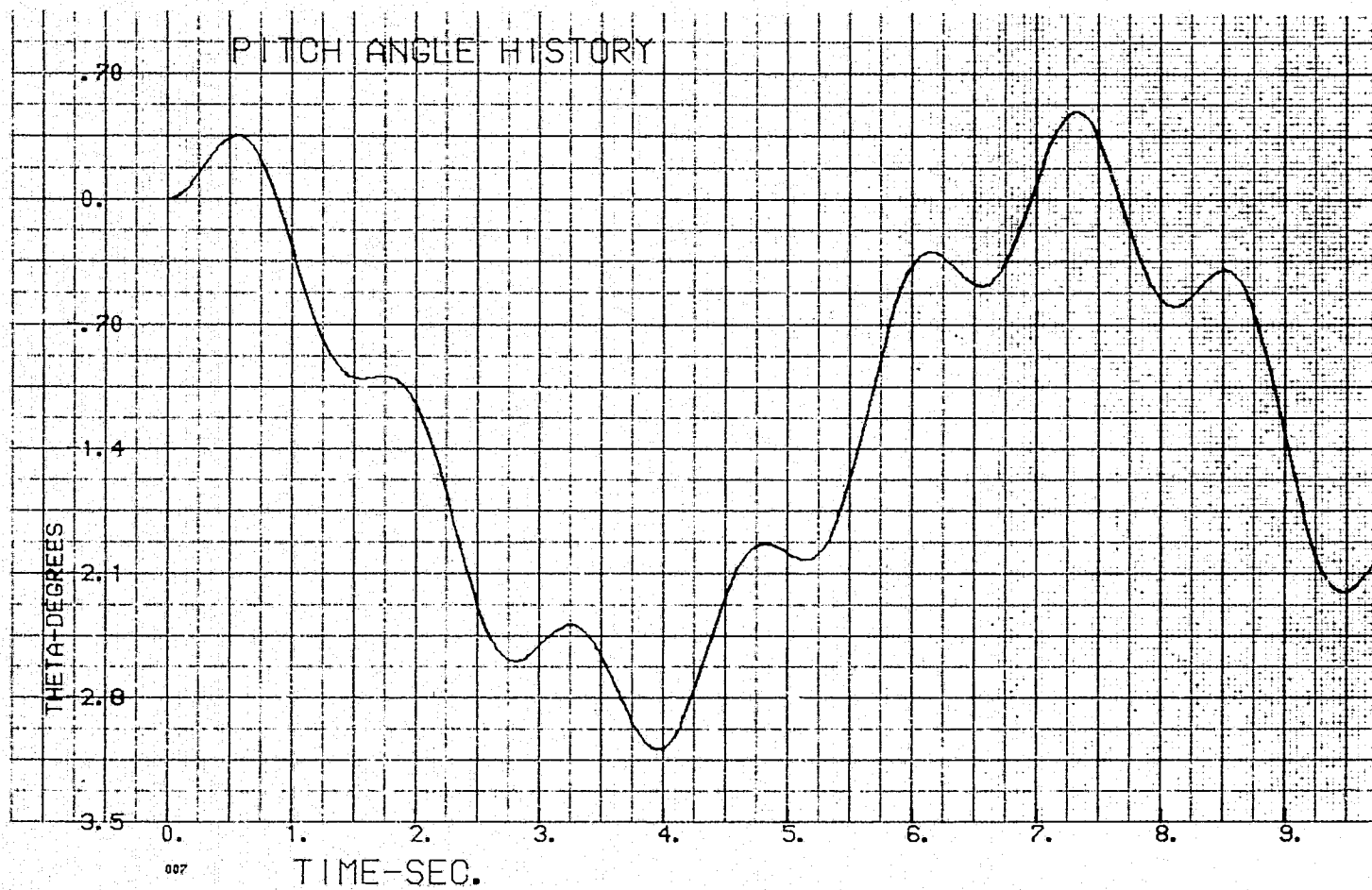
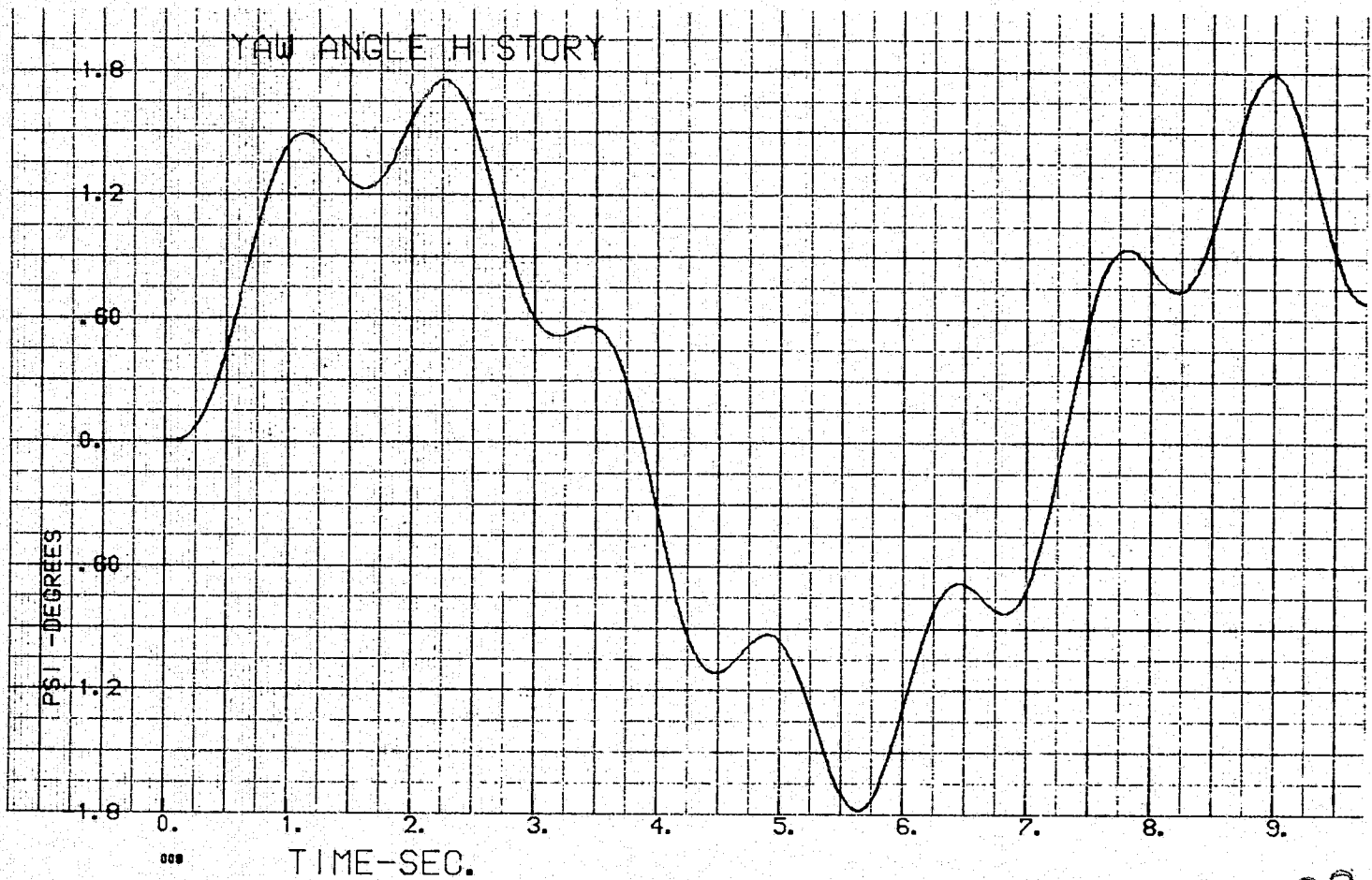

Figure 3-9. Pitch Angle History



3-46

Figure 3-10. Yaw Angle History

ORIGINAL PAGE IS
OF POOR QUALITY

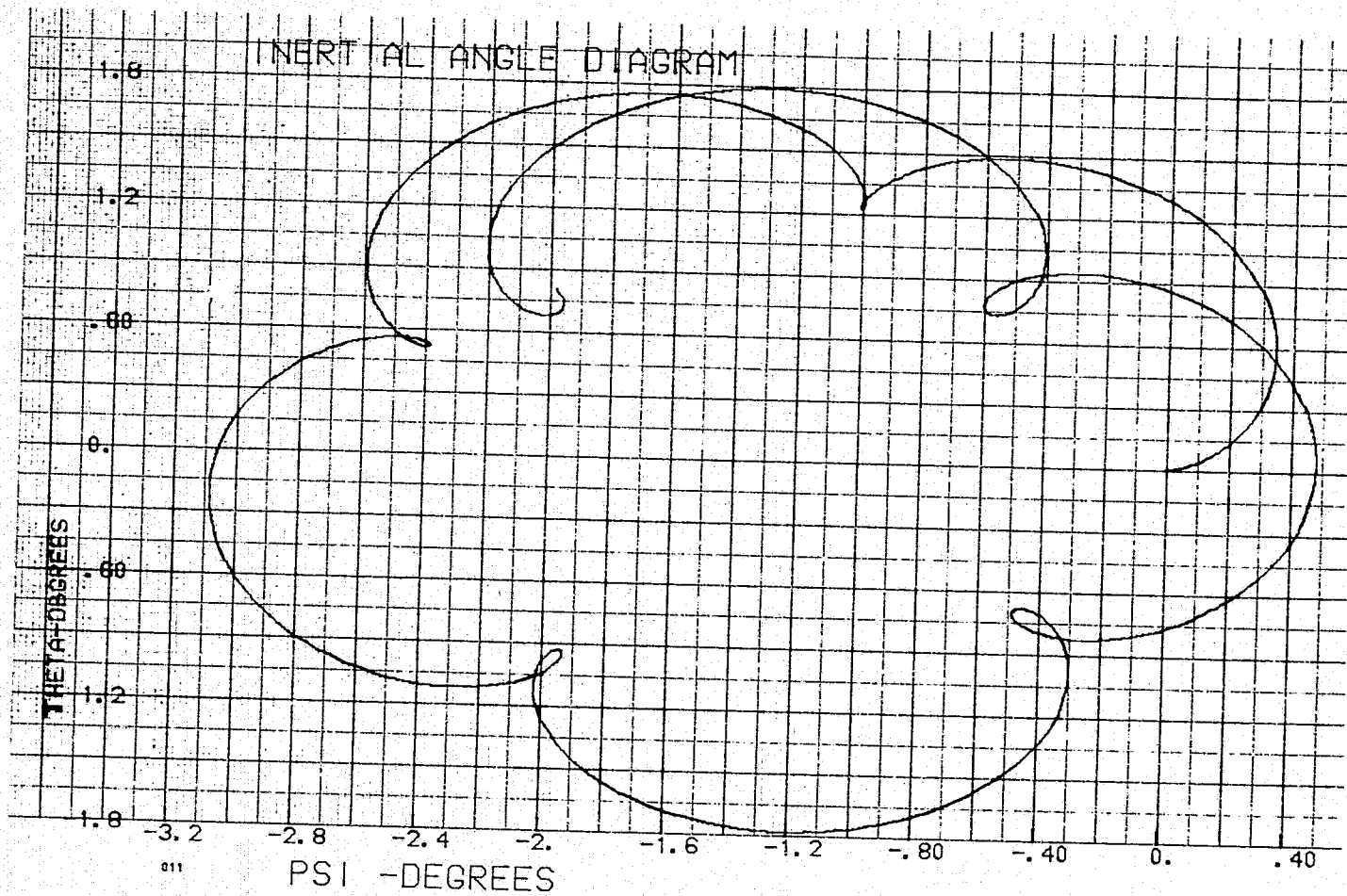

Figure 3-11. Inertial Angle Diagram

For the example shown, the precessional period (for constant inertias) is

$$P = \frac{2\pi}{\Omega_2} = 7.66 \text{ sec}$$

At the end of the first revolution, at 7.4 sec rather than 7.66 sec because of varying inertias, the heading error was 1.274 deg. From Table 3-20, for the AS-05A the final heading error was 1.322 deg; hence, the averaging process works well even in one revolution. From Reference 1,* the heading error for constant inertia and torque is:

$$\gamma = \frac{T}{I_R \omega_S^2} \left(\frac{180}{\pi} \right) = 1.30 \text{ deg}$$

Therefore, the simplified equations from the reference are valid as long as the initial values of torque and inertia are used. A word of caution, though. The heading error shifts at motor shutdown; therefore, if heading error or nutation after the burn is desired, one should then use the final values of torque and inertia.

*H. I. Leon, Spin Dynamics of Rockets and Space Vehicles in Vacuum, STL-TR-59-0000-00787, TRW Systems Group Redondo Beach, Calif. (6 September 1959).

3.4 ACCURACY ANALYSIS

3.4.1 Introduction

A preliminary error analysis for the SSUS was performed early in the study. Since that time, the error sources have been revised. In addition, a method for achieving an improved insertion by using a "guided" apogee burn was devised using the latest values of the error sources and including an estimate for the error reduction employing the "guided" burn technique.

The dynamic effects of initial attitude errors depend upon the characteristics of the spinning vehicle. Since the SSUS could be used for a wide variety of vehicles and payloads, these differing dynamic error sources should be noted. Hence, the vehicle and payload error analysis will depend upon

- a. Pitch/Roll Moment of Inertia
- b. C.G. Location
- c. Spin Rate
- d. Thrust Offsets
- e. Spin Table Misalignments

as well as other terms. A preliminary computation of these error sources was shown earlier in Figures 3-2 through 3-5.

All results are for synchronous equatorial injection. A nominal trajectory is given in Table 3-21. The burns and orbits deviate from the usual Hohmann format since these standard burns and orbits cannot always be achieved using fixed solid motors.

The results apply to all of the payloads studied. These include EO-09A, EO-59A, EO-62A, EO-07A, EO-57A, EO-58A, and AS-05A. Dynamic thrust attitude errors for these payloads are calculated under 3.4.10, and data for these calculations were given in Figures 3-2 through 3-5, as mentioned above.

Table 3-21. (9 pages)

*** TRACE66 EPHEMERIS OUTPUT KEY ***

DATE,...	ME,MM,ST,DT	X,XD	X,XD - 6F	A0BA6V	LAT,...	REV,...	REMARK
YR/MO/DAY	MIN FROM EPOCH	X (FT)	X (FT)	ALPHA (DEG)	LATITUDE (DEG)	REV COUNT	.
HR/MIN	MIN FROM MIDNIGHT	Y (FT)	Y (FT)	DELTA (DEG)	LONGITUDE (DEG)	PERIOD	.
SEC	SEC FROM MIDNIGHT	Z (FT)	Z (FT)	BETA (DEG)	ALTITUDE (NM)	PERIOD-DECAY	.
IT	STEP SIZE (MIN)	XD (FT/SEC)	XD (FT/SEC)	AZIMUTH (DEG)	S-VEH-LAT (DEG)	NOD-REG	.
	UTC - IT	YD (FT/SEC)	YD (FT/SEC)	R (FT)	I (DEG)		
	UT1 - IT	ZD (FT/SEC)	ZD (FT/SEC)	V (FT/SEC)	O (DEG)		

SPECIAL OUTPUT OPTIONS REQUESTED

- * C APOGEE-PERIGEE
- * D MIN AND MAX HEIGHT ABOVE THE OBLATE EARTH *
- * K KEPLERIAN ELEMENTS

*** ECI TRAJECTORY ***

ORIGINAL PAGE IS ON FORM 88-100

ORIGINAL PAGE IS
OF POOR QUALITY

*** CASE 1
*** DISPERSION ANALYSIS - NOMINAL CASE - MAR., 31, 1975

*** EPOCH PRINT.

DATE,...	ME,MM,ST,DT,...	X,XD	X,XD - BF	ADBARV	LAT, BF	REV,...
71/ 5/14	0.00000	-1.10271600E+10	-727.0230E+07	163.0328E+10	27.85264770	0.286000
U.00000	0.00000	-1.10271600E+10	-727.0230E+07	163.0328E+10	27.85264770	0.286000
IT	0.00000	-1.10271600E+10	-727.0230E+07	163.0328E+10	27.85264770	0.286000
A ==	.243351E+10	MEAN ANOM ==	.360000E+10	APOGEE ==	.4469341E+10	
E ==	.11572929E+10	ECCENTRIC ==	.360000E+10	HEIGHT ==	.10270109E+10	
I ==	.2848354E+10	TRUE ANOM ==	.360000E+10	PERIGEE ==	.35414533E+10	
O ==	.088548E+10	K-PL PER ==	.100000E+10	HEIGHT ==	.100000E+10	
U ==	.10290467E+10	ANOM PER ==	.100000E+10	O-DOT ==	-.360000E+10	
TAU ==	-1.059227E+10	NJOL PER ==	.100000E+10	U-DOT ==	.360000E+10	

*** REQUESTED PRINTS

DATE,...	ME,MM,ST,DT,...	X,XD	X,XD - BF	ADBARV	LAT, BF	REV,...
71/ 5/14	0.00000	-1.10271600E+10	-727.0230E+07	163.0328E+10	27.85264770	0.286000
U.00000	0.00000	-1.10271600E+10	-727.0230E+07	163.0328E+10	27.85264770	0.286000
IT	0.00000	-1.10271600E+10	-727.0230E+07	163.0328E+10	27.85264770	0.286000
A ==	.243351E+10	MEAN ANOM ==	.360000E+10	APOGEE ==	.4469341E+10	
E ==	.11572929E+10	ECCENTRIC ==	.360000E+10	HEIGHT ==	.10270109E+10	
I ==	.2848354E+10	TRUE ANOM ==	.360000E+10	PERIGEE ==	.35414533E+10	
O ==	.088548E+10	K-PL PER ==	.100000E+10	HEIGHT ==	.100000E+10	
U ==	.10290467E+10	ANOM PER ==	.100000E+10	O-DOT ==	-.360000E+10	
TAU ==	-1.059227E+10	NJOL PER ==	.100000E+10	U-DOT ==	.360000E+10	

DATE,...	ME,MM,ST,DT,...	X,XD	X,XD - BF	ADBARV	LAT, BF	REV,...	BETA =90
71/ 5/14	0.00000	-1.10271600E+10	-727.0230E+07	163.0328E+10	27.85264770	0.286000	
U.00000	0.00000	-1.10271600E+10	-727.0230E+07	163.0328E+10	27.85264770	0.286000	
IT	0.00000	-1.10271600E+10	-727.0230E+07	163.0328E+10	27.85264770	0.286000	
A ==	.243351E+10	MEAN ANOM ==	.360000E+10	APOGEE ==	.4469341E+10		
E ==	.11572929E+10	ECCENTRIC ==	.360000E+10	HEIGHT ==	.10270109E+10		
I ==	.2848354E+10	TRUE ANOM ==	.360000E+10	PERIGEE ==	.35414533E+10		
O ==	.088548E+10	K-PL PER ==	.100000E+10	HEIGHT ==	.100000E+10		
U ==	.10290467E+10	ANOM PER ==	.100000E+10	O-DOT ==	-.360000E+10		
TAU ==	-1.059227E+10	NJOL PER ==	.100000E+10	U-DOT ==	.360000E+10		

DATE,...	ME,MM,ST,DT,...	X,XD	X,XD - BF	ADBARV	LAT, BF	REV,...	HMIN-MAX
71/ 5/14	0.0234	-1.10271600E+10	.73375621E+07	163.7376E+10	27.83033765	0.286000	

DATE...	M.,MM,ST,DT...	X,XD	X,XD - BF	ADBARV	LAT, BF	REV, PRE-EVNT
71/ 5/14	23.0.0000	-0.755173487E+07	-0.231460067E+08	251.5730555+	-0.93579700	0.54000 PRE-EVNT
5/18	18.92147	-0.193994749E+07	-0.126536935E+07	05.7793467	2.35359370	0.00000
5:28303	1135.28803	-0.333.232	-0.337312324	113.5138496	28.5148749	0.00000
IT	0.0.000	-0.333.232	-0.2.277.130E+13	2336.48672	182.95359355	0.00000
	0.0.000	-0.107-16.11	-0.1187-16.1E+09	25.15324		
A ==	.24347159E+08	MEAN ANOM ==	.63789553E+02	APOGEE ==	.+4693418E+04	
I ==	.11537615E+07	ECCENTRIC ==	.7621313E+02	HEIGHT ==	.10279.9E+04	
O ==	.6513895E+02	TRUE ANOM ==	.763536-1E+02	PERIGEE ==	.3547112E+04	
U ==	.0778713E+02	KEPL PER ==	.180.3530E+03	HEIGHT ==	.10327845E+03	
TAU ==	.10364636E+03	ANOM PER ==	.10389183E+03	O-DOT ==	-.0294.02E+01	
	.13271952E+06	NODL PER ==	.1077.493E+03	U-DOT ==	.0012159E+01	

DATE...	M.,MM,ST,DT...	X,XD	X,XD - BF	ADBARV	LAT, BF	REV, PRE-EVNT
71/ 5/14	23.0.0000	-0.755173487E+07	-0.231460067E+08	251.5730555+	-0.93579700	0.54000 PRE-EVNT
5/23	1335.0.000	-0.257417822E+07	-0.287-17822E+07	83.26257	510.48799228	0.00000
IT	0.0.000	-0.3844382E+07	-0.301917676E+07	117.74199009	-0.59973181	0.00000
	0.0.000	-0.191913889E+07	-0.193021504E+07	24.62476E+08	28.51267622	
	0.0.000	-0.13012183E+07	-0.115-12183E+07	2.32051E+09	181.33151977	
A ==	.24347159E+08	MEAN ANOM ==	.7757378E+02	APOGEE ==	.+4675672E+04	
I ==	.11537615E+07	ECCENTRIC ==	.8423270E+02	HEIGHT ==	.10261342E+04	
O ==	.28512670E+02	TRUE ANOM ==	.5034554E+02	PERIGEE ==	.3543927E+04	
U ==	.0778713E+02	KEPL PER ==	.100.1705E+03	HEIGHT ==	.10415971E+03	
TAU ==	.10364636E+03	ANOM PER ==	.10289153E+03	O-DOT ==	-.0293378E+01	
	.12558457E+06	NODL PER ==	.1057.466E+03	U-DOT ==	.0019696E+01	

** VELOCITY ADJUST (PKICK)

DATE...	M.,MM,ST,DT...	X,XD	X,XD - BF	ADBARV	LAT, BF	REV, PST-EVNT
71/ 5/14	23.0.0000	-0.755173487E+07	-0.231460067E+08	251.5730555+	-0.93579700	0.54000 PST-EVNT
5/23	1335.0.000	-0.257417822E+07	-0.287-17822E+07	83.26257	510.48799228	0.00000
IT	0.0.000	-0.3844382E+07	-0.301917676E+07	117.74199009	-0.59973181	0.00000
	0.0.000	-0.191913889E+07	-0.193021504E+07	24.62476E+08	28.51267622	
	0.0.000	-0.13012183E+07	-0.115-12183E+07	2.32051E+09	181.33151977	

IT	1.40000 1.00000	-1.13321E+01 -1.32430E+01	-2.06233E+09 -1.92433E+09	.2192776E+09 .3197976E+09	29.31207627 181.33691977	
A	.01386267E+06	MEAN ANOM	.180811-7E+01	APOGEE	.22005308E+05	
E	.70683212E+06	ECCENTRIC	.043112-2E+01	HEIGHT	.19445505E+05	
I	.28512076E+02	TRUE ANOM	.15333475E+03	PERIGEE	.39011309E+04	
O	.877866E+02	K PL PER	.043112E+01	HEIGHT	.45019820E+03	
U	.7891433E+03	ANOM PER	.043112E+01	O-DOT	-.30038708E+01	
TAU	.19601651E+02	NOUL PER	.043112E+01	U-DOT	-.90020846E+00	
DATE	M,MM,ST,DT	X,XD	X,XD - BF	ADBARV	LAT, BF	REV
71/ 2/14	23.00000	.231701131E+03	.231701131E+03	291.052970000	-0.97778793	.54031
1/ 23	23.00000	.61173033E+07	.61173033E+07	-6.90175344	1.33104910	0.00000
1.20000	1331.20000	-.28920349E+07	-.28920349E+07	03.92799936	517.19163849	0.00000
IT	0.00000	-.1732331E+01	-.2061089E+03	.117.324320	-.03717300	0.00000
	0.00000	-.1732323E+01	-.1920323E+03	.24067240E+06	20.01021357	
				.31572491E+05	181.92449103	
A	.1388031E+08	MEAN ANOM	.18992113E+01	APOGEE	.22839359E+05	
E	.7086312E+06	ECCENTRIC	.04303353E+01	HEIGHT	.19445505E+05	
I	.28512076E+02	TRUE ANOM	.15333475E+02	PERIGEE	.39011309E+04	
O	.877866E+02	K PL PER	.043112E+01	HEIGHT	.45019820E+03	
U	.7891433E+03	ANOM PER	.043112E+01	O-DOT	-.30038708E+01	
TAU	.19601651E+02	NOUL PER	.043112E+01	U-DOT	-.90020846E+00	
DATE	M,MM,ST,DT	X,XD	X,XD - BF	ADBARV	LAT, BF	REV
71/ 5/14	00.00000	.10094277E+04	.04517621E+03	34.09721220	-27.79155696	.78741
1/	00.00000	-.11075137E+06	-.3217621E+03	-2.065210000	97.497434255	0.00000
1.00000	36.00000	-.224327E+06	-.22845271E+03	0.18030000	-66.3469573	0.00000
IT	0.00000	.10317928E+01	.13593552E+03	02.733841	20.75992359	0.00000
	0.00000	.1127274E+01	.1433228E+03	.2527776E+03	06.53171408	
		-.2902386E+01	-.22693238E+03	.19953779E+03	172.31642644	
A	.01181124E+08	MEAN ANOM	.2252702E+01	APOGEE	.22820405E+05	
E	.7086312E+06	ECCENTRIC	.04303353E+01	HEIGHT	.19445505E+05	
I	.28493817E+02	TRUE ANOM	.15333475E+02	PERIGEE	.39011309E+04	
O	.8729330E+02	K PL PER	.043112E+01	HEIGHT	.45019820E+03	
U	.7911313E+03	ANOM PER	.043112E+01	O-DOT	-.30038708E+01	
TAU	.1961177E+02	NOUL PER	.043112E+01	U-DOT	-.90020846E+00	
DATE	M,MM,ST,DT	X,XD	X,XD - BF	ADBARV	LAT, BF	REV
71/ 3/14	120.00000	.77066482E+03	-.40975304E+03	2.73593137	-10.99090812	.88406
2/	120.00000	.2930332E+03	-.72110202E+03	-10.77491001	109.57499372	0.00000
1.00000	720.00000	-.27725599E+03	-.27745790E+03	0.11321000	1.950007281552	0.00000
IT	0.00000	.10317928E+01	.13593552E+03	07.90393339	-10.90259742	0.00000
	0.00000	.10317928E+01	.13593552E+03	07.90393339	20.807855483	
		.23379331E+03	.32397323E+03	.12180711E+05	136.95951173	
A	.01173273E+08	MEAN ANOM	.25392435E+02	APOGEE	.22818167E+05	
E	.70798117E+06	ECCENTRIC	.0631903E+02	HEIGHT	.19374234E+05	
I	.28541816E+02	TRUE ANOM	.13336204E+03	PERIGEE	.39012927E+04	
O	.8713389E+02	K PL PER	.04322606E+03	HEIGHT	.4573598E+03	
U	.7902545E+03	ANOM PER	.0430378E+03	O-DOT	-.30013058E+01	
TAU	.19593346E+02	NOUL PER	.04326078E+03	U-DOT	-.9849314E+00	
DATE	M,MM,ST,DT	X,XD	X,XD - BF	ADBARV	LAT, BF	REV
71/ 3/14	130.00000	.09031481E+06	-.53799273E+03	3.04313002	-12.20080501	.92713

DATE	M, MM, ST, DT, ..	X, XD	X, XD - BF	ADBARV	LAT, .. BF	REV, ..
71/ 9/14	342.33858	.737057831	-.263337086	57.02472013	-.46810441	.39693 HMIN-MAX
IT	0.00000	.113033971	.106111221	-.0503133	104.95393135	0.00000
A	.01173211	MEAN ANOM	.17493921	APOGEE	.22817310	0.00000
IOD	.0079900	ECCENTRIC	.17433977	HEIGHT	.19373337	0.00000
U	.08711332	TRUE ANOM	.17333951	PERIGEE	.39348710	0.00000
TAU	.19593548	K-PL PER	.04331779	HEIGHT	.45748108	0.00000
		ANOM PER	.04331779	O-DOT	-.30617673	
		NOGL PER	.04331779	U-DOT	.49815722	
DATE	M, MM, ST, DT, ..	X, XD	X, XD - BF	ADBARV	LAT, .. BF	REV, ..
71/ 9/14	342.33858	.737057831	-.263337086	57.02472013	-.46810441	.39693 HMIN-MAX
IT	0.00000	.113033971	.106111221	-.0503133	104.95393135	0.00000
A	.01173211	MEAN ANOM	.17493921	APOGEE	.22817310	0.00000
IOD	.0079900	ECCENTRIC	.17433977	HEIGHT	.19373337	0.00000
U	.08711332	TRUE ANOM	.17333951	PERIGEE	.39348710	0.00000
TAU	.19593548	K-PL PER	.04331779	HEIGHT	.45748108	0.00000
		ANOM PER	.04331779	O-DOT	-.30617673	
		NOGL PER	.04331779	U-DOT	.49815722	
DATE	M, MM, ST, DT, ..	X, XD	X, XD - BF	ADBARV	LAT, .. BF	REV, ..
71/ 9/14	342.33858	.737057831	-.263337086	57.02472013	-.46810441	.39693 HMIN-MAX
IT	0.00000	.113033971	.106111221	-.0503133	104.95393135	0.00000
A	.01173211	MEAN ANOM	.17493921	APOGEE	.22817310	0.00000
IOD	.0079900	ECCENTRIC	.17433977	HEIGHT	.19373337	0.00000
U	.08711332	TRUE ANOM	.17333951	PERIGEE	.39348710	0.00000
TAU	.19593548	K-PL PER	.04331779	HEIGHT	.45748108	0.00000
		ANOM PER	.04331779	O-DOT	-.30617673	
		NOGL PER	.04331779	U-DOT	.49815722	
DATE	M, MM, ST, DT, ..	X, XD	X, XD - BF	ADBARV	LAT, .. BF	REV, ..
71/ 9/14	342.33858	.737057831	-.263337086	57.02472013	-.46810441	.39693 HMIN-MAX
IT	0.00000	.113033971	.106111221	-.0503133	104.95393135	0.00000
A	.01173211	MEAN ANOM	.17493921	APOGEE	.22817310	0.00000
IOD	.0079900	ECCENTRIC	.17433977	HEIGHT	.19373337	0.00000
U	.08711332	TRUE ANOM	.17333951	PERIGEE	.39348710	0.00000
TAU	.19593548	K-PL PER	.04331779	HEIGHT	.45748108	0.00000
		ANOM PER	.04331779	O-DOT	-.30617673	
		NOGL PER	.04331779	U-DOT	.49815722	
DATE	M, MM, ST, DT, ..	X, XD	X, XD - BF	ADBARV	LAT, .. BF	REV, ..
71/ 9/14	342.33858	.737057831	-.263337086	57.02472013	-.46810441	.39693 HMIN-MAX
IT	0.00000	.113033971	.106111221	-.0503133	104.95393135	0.00000
A	.01173211	MEAN ANOM	.17493921	APOGEE	.22817310	0.00000
IOD	.0079900	ECCENTRIC	.17433977	HEIGHT	.19373337	0.00000
U	.08711332	TRUE ANOM	.17333951	PERIGEE	.39348710	0.00000
TAU	.19593548	K-PL PER	.04331779	HEIGHT	.45748108	0.00000
		ANOM PER	.04331779	O-DOT	-.30617673	
		NOGL PER	.04331779	U-DOT	.49815722	

DATE,...	ME,MM,ST,DT,..	X,XD	X,XD - BF	ADBARV	LAT,.. BF	REV,...
71/ 5/14	3+2.3+000	.737634639E+08	-.263431643E+03	57.85488233	-.46807903	.99694 BETA =90
5/42	3+2.3+000	.117383600E+09	-.136110234E+03	-.46494612	100.95375756	0.00000
20.30230	205+0.30238	-.112503424E+07	-.112503424E+07	90.00011080	19373.37706579	0.00000
	4.00000	-.053523258E+04	.284376079E+02	89.53723843	-.46541629	0.00000
	0.00000	.536349340E+04	.548808960E+01	.13864633E+09	.46495450	
	0.00000	+.91287437E+00	.491287437E+01	.10080539E+05	190.60974961	
A =	.1173211E+06	MEAN ANOM =	.18000000E+03	APOGEE =	.22817310E+05	
E =	.6790137E+00	ECCENTRIC =	.18100000E+03	HEIGHT =	.19373377E+05	
I =	.2850357E+02	TRUE ANOM =	.18100000E+03	PERIGEE =	.39014715E+04	
O =	.6711132E+02	K-PL PER =	.6450177E+03	HEIGHT =	-.573803E+03	
U =	.1796255E+03	ANOM PER =	.64503779E+03	O-DOT =	-.30617673E+00	
TAU =	.1958849E+02	NODL PER =	.64503714E+03	U-DOT =	+.9845702E+00	

DATE,...	ME,MM,ST,DT,..	X,XD	X,XD - BF	ADBARV	LAT,.. BF	REV,...
71/ 5/14	3+2.3+000	.737634639E+08	-.263431643E+03	57.85488233	-.46807903	.99694 PRE-EVNT
5/42	3+2.3+000	.117383600E+09	-.136110234E+03	-.46494612	100.95375756	0.00000
20.40J00	205+0.30238	-.112503424E+07	-.112503424E+07	90.00011080	19373.37706560	0.00000
	4.00000	-.053523258E+04	.284376079E+02	89.53723843	-.46541629	0.00000
	0.00000	.536349340E+04	.548808960E+01	.13864633E+09	.46495450	
	0.00000	+.91287437E+00	.491287437E+01	.10080539E+05	190.60974961	
A =	.51173211E+06	MEAN ANOM =	.18000000E+03	APOGEE =	.22817310E+05	
E =	.0796037E+00	ECCENTRIC =	.18100000E+03	HEIGHT =	.19373377E+05	
I =	.2850357E+02	TRUE ANOM =	.18100000E+03	PERIGEE =	.39014715E+04	
O =	.8711132E+02	K-PL PER =	.6450177E+03	HEIGHT =	-.573803E+03	
U =	.1796255E+03	ANOM PER =	.64503779E+03	O-DOT =	-.30617673E+00	
TAU =	.1958849E+02	NODL PER =	.64503714E+03	U-DOT =	+.9845702E+00	

*+ VELOCITY ADJUST (PKICK)

DATE,...	ME,MM,ST,DT,..	X,XD	X,XD - BF	ADBARV	LAT,.. BF	REV,...
71/ 5/14	3+2.3+000	.737634639E+08	-.263431643E+03	57.85488233	-.46807903	.99694 PST-EVNT
5/42	3+2.3+000	.117383600E+09	-.136110234E+03	-.46494612	100.95375756	0.00000
20.40J00	205+0.30238	-.112503424E+07	-.112503424E+07	90.00011080	19373.37706560	0.00000
	4.00000	-.053523258E+04	.284376079E+02	89.53723843	-.46541629	0.00000
	0.00000	.536349340E+04	.548808960E+01	.13864633E+09	.46495450	
	0.00000	+.91287437E+00	.491287437E+01	.10080539E+05	190.60974961	
A =	.1307545E+05	MEAN ANOM =	.35980552E+03	APOGEE =	.22854929E+05	
E =	.3236674E-03	ECCENTRIC =	.35980541E+03	HEIGHT =	.19410996E+05	
I =	.6495451E+00	TRUE ANOM =	.35980530E+03	PERIGEE =	.22817310E+05	
O =	.4751087E+03	K-PL PER =	.14420166E+04	HEIGHT =	-.19373377E+05	
U =	.2704787E+03	ANOM PER =	.14425631E+04	O-DOT =	-.13273691E-01	
TAU =	-.10997376E+04	NODL PER =	.14424566E+04	U-DOT =	-.26545891E-01	

DATE,...	ME,MM,ST,DT,..	X,XD	X,XD - BF	ADBARV	LAT,.. BF	REV,...
71/ 5/14	3+2.35000	.737503427E+08	-.263431473E+03	57.85734200	-.40807890	.99694

5/12 3+2.3500E+01 .117386016E+03 .136111237E+03 .00000000E+00 100.95375038 9.000000
 21.0000 205-1.0000E+00 -.112503395E+07 -.112503395E+07 30.00000000E+00 13373.37706309 9.000000
 IT 0.000000 .000000 -.0531+0000E+04 .20475530E+02 .09.99710000E+00 .40541617
 0.000000 .000000 .000000 .000000 .1386+0000E+09 .46496285
 0.000000 .000000 .000000 .000000 .10080539E+05 130.35906862

A E I O U TAU = .13875492E+09 MEAN ANOM = .35386796E+03 APOGEE = .22054929E+05
 .02366856E-03 ECCENTRIC = .35980779E+03 HEIGHT = .19410996E+05
 .16495450E+00 TRUE ANOM = .35980779E+03 PERIGEE = .22817310E+05
 .14751086E+03 KEPL PER = .14426166E+04 HEIGHT = .19373377E+05
 .27048500E+03 ANOM PER = .14+25631E+04 O-DOT = -.13273601E-01
 -1.0997372E+04 NODL PER = .1442+560E+04 U-DOT = .26545891E-01

DATE... ME,MM,ST,DT,.. X,XD X,XD - BF ADBARV LAT,.. BF REV...
 71/ 5/14 3+2.9044E+00 .7377+3009E+06 -.263422019E+03 57.99580372 .46007069 .99729 BEIA =90
 5/42 3+2.9044E+00 .11750+822E+09 .136111420E+03 .46+93784 100.95335245 0.000000
 54.25489 20574.25481 -.112501421E+07 -.112501421E+07 90.00000000E+00 19373.37701125 0.000000
 IT 0.000000 .000000 -.05+839+76E+04 .28433600E+02 .09.996000+17 .46540800 0.000000
 0.000000 .000000 .000000 .000000 .55086413E+01 .1386+0000E+09 .46496285
 0.000000 .000000 .000000 .000000 .0924+2439E+05 .6924+2439E+05 .10080539E+05 190.35905816

A E I O U TAU = .13875492E+09 MEAN ANOM = .36000000E+03 APOGEE = .22854329E+05
 .02366856E-03 ECCENTRIC = .36000000E+03 HEIGHT = .19410996E+05
 .16495450E+00 TRUE ANOM = .36000000E+03 PERIGEE = .22817310E+05
 .14751086E+03 KEPL PER = .14426166E+04 HEIGHT = .19373377E+05
 .27048500E+03 ANOM PER = .14+25631E+04 O-DOT = -.13273601E-01
 -1.0997125E+04 NODL PER = .14+24566E+04 U-DOT = .26545891E-01

DATE... ME,MM,ST,DT,.. X,XD X,XD - BF ADBARV LAT,.. BF REV...
 71/ 5/14 3+2.9044E+00 .7377+3009E+06 -.263422016E+03 57.99592504 .46007069 .99729 HMIN-MAX
 5/42 3+2.9044E+00 .11750+822E+09 .136111420E+03 .46+93783 100.95335233 0.000000
 54.25481 20574.25481 -.112501421E+07 -.112501421E+07 89.99999997 13373.37701125 0.000000
 IT 0.000000 .000000 -.05+839661E+04 .28433600E+02 .09.996006383 .46540800 0.000000
 0.000000 .000000 .000000 .000000 .55086413E+01 .1386+0000E+09 .46496285
 0.000000 .000000 .000000 .000000 .092501382E+05 .692501382E+05 .10080539E+05 190.35905816

A E I O U TAU = .13875492E+09 MEAN ANOM = .391733+2E-04 APOGEE = .22854929E+05
 .02366856E-03 ECCENTRIC = .39205635E+03 HEIGHT = .19410996E+05
 .16495450E+00 TRUE ANOM = .39237940E+03 PERIGEE = .22817310E+05
 .14751086E+03 KEPL PER = .14426166E+04 HEIGHT = .19373377E+05
 .27048500E+03 ANOM PER = .14+25631E+04 O-DOT = -.13273601E-01
 .34297409E+03 NODL PER = .14424566E+04 U-DOT = .26545891E-01

DATE... ME,MM,ST,DT,.. X,XD X,XD - BF ADBARV LAT,.. BF REV...
 6/ 0 300.000000 .00+3098297E+03 -.263130813E+03 62.26928031 .466647410 .99043
 0.000000 21600.000000 .122713212E+09 .136115393E+09 .460335193 100.94106768 0.000000
 IT 1.000000 -.892240923E+04 .283609568E+02 .09.96142787 13373.42688082 0.000000
 0.000000 .000000 .000000 .000000 .613995717E+01 .1386+0000E+09 .46501230 0.000000
 0.000000 .000000 .000000 .000000 .678131281E+01 .678131281E+01 .10080517E+05 166.09771413

A E I O U TAU = .13675492E+09 MEAN ANOM = .40759234E+01 APOGEE = .22854928E+05
 .02366824E-03 ECCENTRIC = .40792803E+01 HEIGHT = .19410996E+05
 .16495446E+00 TRUE ANOM = .40325366E+01 PERIGEE = .22817312E+05
 .14751086E+03 KEPL PER = .14+25166E+04 HEIGHT = .19373379E+05
 .27067592E+03 ANOM PER = .14+25632E+04 O-DOT = -.13273600E-01
 .3+365668E+03 NODL PER = .14+2-566E+04 U-DOT = .26545888E-01

3-56

DATE,...	ME,MM,ST,DT,...	X, XD	X, XD - BF	ADBARV	LAT, .. BF	REV,...
71/ 5/14	420.00000	.325517353+08	-.26210434E+09	77.26667755	-.44953602	0.00000
7/ U	420.00000	.139232976+09	.136142815E+09	- .43798744	100.89736632	0.00000
0.00000	25200.00000	-.105063216+07	-.105688216E+07	89.9851335E	19374.38218111	0.00000
IT	0.00000	-.983192931E+04	-.268528966E+02	89.8428300E	-.43802993	0.00000
	0.00000	.222454367E+04	.843382016E+01	.13864674E+05	.46917697	
	0.00000	.276300790E+02	.276300790E+02	.10680096E+05	169.75190635	
A =	.13875494E+09	MEAN ANOM =	.18393067E+02	APOGEE =	.22854836E+05	
E =	.02183916E+03	ECCENTRIC =	.18407936E+02	HEIGHT =	.19410957E+05	
I =	.0495637E+00	TRUE ANOM =	.18422811E+02	PERIGEE =	.22817355E+05	
O =	.14791956E+03	KEPL PER =	.14+26169E+04	HEIGHT =	.19373422E+05	
U =	.27133368E+03	ANOM PER =	.14+25963E+04	O-DOT =	-.13273595E-01	
TAU =	.34629443E+03	NODL PER =	.14+25969E+04	U-DOT =	.26545878E-01	

DATE,...	ME,MM,ST,DT,...	X, XD	X, XD - BF	ADBARV	LAT, .. BF	REV,...
71/ 5/14	480.00000	-.047223224E+07	-.261033953E+08	92.26182927	-.38459538	0.00000
8/ U	480.00000	.138828444E+09	.136177663E+09	- .38202120	100.85147945	0.00000
0.00000	28800.00000	-.024593548E+06	-.92450958E+05	89.97462828	19376.49124463	0.00000
IT	0.00000	-.104713922E+05	.304628874E+02	89.73495574	-.38249747	0.00000
	0.00000	-.439310889E+03	.147004268E+02	.13865955E+05	.46719320	
	0.00000	.162941933E+02	.465941933E+02	.1007916E+05	155.70552396	
A =	.13875495E+09	MEAN ANOM =	.32759225E+02	APOGEE =	.22854600E+05	
E =	.01773273E+03	ECCENTRIC =	.32784306E+02	HEIGHT =	.19416867E+05	
I =	.04955980E+00	TRUE ANOM =	.32809927E+02	PERIGEE =	.22817450E+05	
O =	.14751875E+03	KEPL PER =	.14+25971E+04	HEIGHT =	.19373517E+05	
U =	.27194226E+03	ANOM PER =	.14+25967E+04	O-DOT =	-.13273590E-01	
TAU =	.34872563E+03	NODL PER =	.14+25971E+04	U-DOT =	.26545868E-01	

DATE,...	ME,MM,ST,DT,...	X, XD	X, XD - BF	ADBARV	LAT, .. BF	REV,...
71/ 5/14	500.00000	-.175218645E+08	-.260669917E+08	97.25946968	-.15988865	0.89332
6/29	500.00000	.137551037E+09	.136190357E+09	- .35747983	100.83543033	0.00000
0.00000	30000.00000	-.4865104577E+05	-.865154577E+05	89.97147846	19377.42793931	0.00000
IT	0.00000	-.999634668E+04	.312274784E+02	89.78263166	-.35784127	0.00000
	0.00000	-.126626271E+04	.111173321E+02	.13866524E+05	.47129196	
	0.00000	.522679349E+02	.522679349E+02	.10076752E+05	150.16784025	
A =	.13875495E+09	MEAN ANOM =	.37565386E+02	APOGEE =	.22854759E+05	
E =	.01597529E+03	ECCENTRIC =	.37593937E+02	HEIGHT =	.19410826E+05	
I =	.04961115E+00	TRUE ANOM =	.37622438E+02	PERIGEE =	.22817492E+05	
O =	.14751885E+03	KEPL PER =	.14+26172E+04	HEIGHT =	.19373559E+05	
U =	.27212759E+03	ANOM PER =	.14+25963E+04	O-DOT =	-.13273588E-01	
TAU =	.34946536E+03	NODL PER =	.14+25972E+04	U-DOT =	.26545865E-01	

DATE,...	ME,MM,ST,DT,...	X, XD	X, XD - BF	ADBARV	LAT, .. BF	REV,...
71/ 5/14	506.34000	-.213180576E+08	-.260554628E+08	95.84362753	-.35147635	0.88892 PST-EVNT
6/20	506.34000	.137016110E+09	.136194742E+09	- .34912383	100.83024860	0.00000
20.00000	30330.40000	-.044943896E+05	-.844943896E+05	89.97052407	19377.74729440	0.00000
IT	0.00000	-.995949575E+04	.314917381E+02	89.692991206	-.34947642	0.00000
	0.00000	-.154399731E+04	.116388129E+02	.13866718E+05	.46496159	
	0.00000	.539834243E+02	.539834243E+02	.10078611E+05	149.49507034	
A =	.13875496E+09	MEAN ANOM =	.39191177E+02	APOGEE =	.22854745E+05	
E =	.01553308E+03	ECCENTRIC =	.3912653E+02	HEIGHT =	.19410813E+05	
I =	.04961159E+00	TRUE ANOM =	.3915138E+02	PERIGEE =	.22817566E+05	

3-57

O == :14758045E+03 KEPL PER == :14426172E+04 HEIGHT == :19373573E+06
U == :27218310E+03 ANOR PER == :14425638E+04 U-DOT == -13273567E+06
TAU # :36963110E+03 NOBL PER # :14424572E+04 U-DOT # :26545864E+06

*** END OF TRAJECTORY ***

3.4.2 Separation Sequence

The SSUS may be deployed from the Orbiter using a spin table. Then the separation sequence is as follows:

- a. Orbiter positioning using star tracker on cradle/spin table
- b. Orientation of SSUS and spin table
- c. SSUS spinup
- d. Separation maneuver/release from cradle and Orbiter backoff (This maneuver causes tip-off rates that can cause dynamic attitude errors.)

A deployment sequence may also be used that depends upon the payload attitude control system to provide SSUS stabilization prior to firing spinup rockets. It is felt that this latter technique is less accurate than the former. Hence, the spin table is assumed in this analysis.

3.4.3 Initial Position and Velocity Error Sources

The SSUS will have initial position and velocity errors when it is deployed from the Orbiter. Contributions to these error sources arise from

- a. Orbiter navigation and control system
- b. Separation sequence and time delays
- c. Separation tip-off forces

The errors resulting from Item a. above are detailed in JSC-07700, Vol. 14, Change No. 3, Table 3.1, and are listed in the following table:

	<u>JSC-07700</u> <u>Vol. 14</u>	<u>Assumed SSUS</u> <u>Initial Errors</u>
ΔV_T	0.5 ft/sec	1 ft/sec
ΔV_R	4.3	5
ΔV_N	2.0	2
ΔP_T	850 ft	900 ft
ΔP_R	470	500
ΔP_N	430	500

It is felt that the translation errors resulting from Items b. and c. above are negligible. Hence, the assumed SSUS initial errors listed above are used in the SSUS error analysis.

3.4.4 SSUS Perigee Burn Errors

The values used in this analysis are the following:

Perigee Attitude Error Source	3 σ Magnitude (deg)			
	EO-57A	AS-05A	EO-07A	EO-09A
Orbiter Positioning (assuming Star Tracker on Cradle/Spin Table)	0.14	0.14	0.14	0.14
Spin Table Spinup	0.2	0.2	0.2	0.2
Release from Spin Table	NEGLIGIBLE			
Time Variation in Start of Perigee Burn	0.2	0.2	0.2	0.2
SSUS Dynamic Thrust Angle Error				
θ_M	0.45	0.742	0.602	0.337
θ_r	0.159	0.122	0.102	0.138
Total RSS	0.572	0.816	0.69	0.482

The SSUS dynamic thrust angle error arises from separation tip-off rates and the offsetting moment that occurs during the perigee burn. Additional discussion of this item is given under 3.4.10. The values listed can be met using a spin table when the SSUS

- o Thrust misalignment = 0.12 deg
- o Tip-off rates ≤ 0.1 deg/sec
- o C.G. offsets ≤ 0.1 in.
- o Spin rate = 100 rpm for EO-57A
= 45 rpm for AS-05A, EO-07A, EO-09A

A specification of ± 3 sec (3σ) on the ignition timing will be assumed.

The solid rocket motor will be assumed to have a total impulse uncertainty of ± 0.75 percent. Hence, a specification value of 8000 (0.75 percent) = 60 ft/sec will be used in the error analysis.

3.4.5 Apogee Burn Error Sources

Error sources for the apogee burn attitude result from the following input errors:

Apogee Attitude Error Source	3σ Magnitude (deg)			
	EO-57A	AS-05A	EO-07A	EO-09A
TTC and Control	0.2	0.2	0.2	0.2
Dynamic Thrust Angle Error				
θ_M	0.393	1.322	0.48	0.23
Total RSS	0.44	1.34	0.52	0.30

The dynamic thrust angle error arises from the moment caused by thrust misalignments and C.G. offsets during the apogee burn. These error sources are discussed in more detail under 3.4.10.

The solid motor ignition timing error may be either initiated by radio command or timer. The 3σ specification value is ± 3 sec. The total impulse is 0.75% which results in an axial velocity error of 0.75 percent of 5600 ft/sec = 42 ft/sec. A specification value of 45 ft/sec will be used.

3.4.6 Error Source Summary

An error analysis for the spinning SSUS will be performed using the following error sources:

3 σ Value for Each Spacecraft

Error Source	Units	EO-57A	AS-05A	EO-07A	EO-09A
Orbiter Separation:					
Velocity Magnitude	ft/sec	1.00	1.00	1.00	1.00
Radial Velocity	ft/sec	5.00	5.00	5.00	5.00
Normal Velocity	ft/sec	2.00	2.00	2.00	2.00
Altitude	ft/sec	500.00	500.00	500.00	500.00
Perigee Burn:					
Ignition Time	sec	3.00	3.00	3.00	3.00
Pitch Attitude	deg	0.57	0.82	0.69	0.48
Yaw Attitude	deg	0.57	0.82	0.69	0.48
Total Kick Velocity	ft/sec	60.00	60.00	60.00	60.00
Apogee Burn:					
Ignition Time	sec	3.00	3.00	3.00	3.00
Pitch Attitude	deg	0.44	1.34	0.52	0.30
Yaw Attitude	deg	0.44	1.34	0.52	0.30
Total Kick Velocity	ft/sec	45.00	45.00	45.00	45.00

The error analysis will be given for the following:

- o Coast or transfer orbit
- o Apogee orbit (unguided apogee burn)
- o Apogee orbit (guided apogee burn)

3.4.7 Coast Orbit Errors

A listing of errors in the T, R, N coordinate system is given at the instant of perigee burnout. The results (3σ) are:

Insertion Parameter	Units	3σ Value for Each Spacecraft			
		EO-57A	AS-05A	EO-07A	EO-09A
ΔV_T	ft/sec	60.7	60.8	60.7	60.7
ΔV_R	ft/sec	60.8	120.3	87.4	72.2
ΔV_N	ft/sec	61.6	120.8	88.0	72.9
ΔP_T	nmi	11.3	11.3	11.3	11.3
ΔP_R	nmi	1.55	1.55	1.55	1.55
ΔP_N	nmi	0.366	0.366	0.366	0.366

Errors have also been obtained for the coast orbit parameters. Three-sigma values for these errors are:

Orbit Parameter	Units	3σ Value for Each Spacecraft			
		EO-57A	AS-05A	EO-07A	EO-09A
Δ Apogee	nmi	597.1	597.1	597.1	597.1
Δ Perigee	nmi	2.93	4.43	3.39	2.61
Δ Period	min	21.72	21.73	21.72	21.72
Δ Eccentricity	none	0.00642	0.00643	0.00642	0.00642
Δ Inclination	deg	0.127	0.211	0.153	0.107

Detailed listings for this analysis are given in Table 3-22.* The partial derivatives and covariance matrix are also given.

*Table 3-22, which is a lengthy computer run, has been placed at the end of the discussion of Accuracy Analysis (3.4) for the convenience of the reader.

3.4.8 Apogee Errors (Unguided Apogee Burn)

A listing of errors in the T, R, N coordinate system is given at the instant of apogee burnout. The results (3σ) are:

Insertion Parameter	Units	3σ Value for Each Spacecraft			
		EO-57A	AS-05A	EO-07A	EO-09A
ΔV_T	ft/sec	115.1	130.0	116.6	116.0
ΔV_R	ft/sec	331.4	358.3	334.1	333.0
ΔV_N	ft/sec	74.9	146.8	86.0	81.2
ΔP_T	nmi	478.9	502.3	487.6	482.3
ΔP_R	nmi	581.1	581.2	581.1	581.1
ΔP_N	nmi	262.9	286.5	268.0	264.8

Orbital errors have also been obtained for the insertion orbit. These are:

Orbit Parameter	Units	3σ Value for Each Spacecraft			
		EO-57A	AS-05A	EO-07A	EO-09A
Δ Apogee	nmi	1422.0	1451.0	1425.0	1424.0
Δ Perigee	nmi	353.2	670.6	395.1	378.7
Δ Period	min	66.8	71.6	67.3	67.1
Δ Eccentricity	none	0.0327	0.0363	0.0331	0.0329
Δ Inclination	deg	0.703	0.795	0.720	0.711

A detailed listing for this analysis is given in Table 3-22. The partial derivatives and covariance matrix are also given.

3.4.9

Apogee Errors (Guided Burn)

An estimate of the errors that result when the attitude of the SSUS is controlled to minimize the insertion errors will be given here.

The vehicle is assumed to use a correction scheme similar to that used on the NATO and SKYNET satellites. This method is also planned for use on FLTSATCOM. Vehicle earth sensor and sun sensor telemetry is processed for several reys to determine the vehicle attitude and ephemeris in orbit. The vehicle attitude is then corrected by firing selected nozzles. A sequence of events is as follows:

- a. An initial coarse attitude maneuver is made to correct the vehicle attitude to within a few degrees of the desired value. No problems have been encountered when these initial maneuvers are as large as 160 deg.
- b. The vehicle is tracked to determine the ephemeris.
- c. Telemetry is again processed to determine the vehicle attitude.
- d. A computer program is used to determine the optimum final attitude and insertion point. The optimum final attitude is that attitude which will constrain inclination and period and minimize ΔV (or hydrazine) to correct the orbit to the desired one.
- e. An attempt is then made to achieve the desired attitude from above. When this operation is satisfactorily completed, telemetry will again be processed to determine the resulting actual attitude.
- f. The actual attitude will be used in the computer program to find the optimum time to fire the rocket motor, assuming that the attitude was as specified in above.

The result of this technique is to reduce the magnitude of the errors given in the unguided case. It is difficult to evaluate the extent of this correction without using a computer program that can generate (Monte Carlo) test orbits and correct these using n dimensional search and optimization procedures. However, an attempt will be made to do this.

In order to illustrate the procedure, Spec values for both the perigee and apogee burn attitude errors will be taken as $\Delta\theta = 1.0$ deg

(3σ). All other errors are as previously specified. Note that all burns satisfy the assumption that the attitude error is within the 1-deg tolerance except the apogee burn for AS-05A (= 1.32 deg). The results for this case are:

Spec Case with Perigee and Apogee Attitude
Errors of 1.0 Degree (3σ)

	<u>Units</u>	<u>Errors After</u> <u>Perigee Burn</u>	<u>Errors After</u> <u>Unguided Apogee Burn</u>
ΔV_T	ft/sec	61.8	123
ΔV_R	ft/sec	126.6	356
ΔV_N	ft/sec	127.8	120
ΔP_T	nmi	18.7	515
ΔP_R	nmi	2.4	582
ΔP_N	nmi	0.43	283

It is considered important to keep the inclination error as small as possible. Hence, the apogee burn may be made when the vehicle crosses the equator ($\Delta P_N = 0$). Then the 1.0-deg (3σ) attitude error will cause the final inclination error. The geometry for the apogee burn is shown in the following figure.

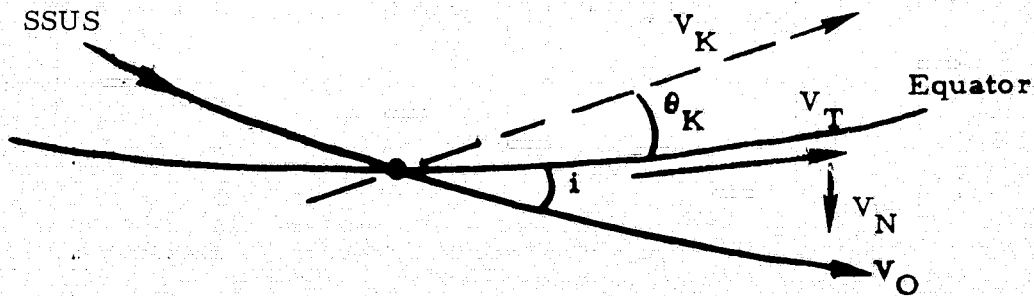

The SSUS is shown crossing the equator. At the equator crossing, the motor will fire in the chosen direction θ_K to result in the desired inclination (chosen as zero in the following analysis).

$$V_O \cos i \oplus V_K \cos \theta_K = V_T$$

$$V_O \sin i = V_K \sin \theta_K = V_N$$

Errors will exist in V_K and in θ_K of

$$\Delta V_K = 45 \text{ ft/sec}$$

$$\Delta \theta_y = 1 \text{ deg}$$

Then

$$\Delta V_T = \Delta V_K \cos \theta_K - V_K \sin \theta_K \Delta \theta_y$$

$$\Delta V_N = -\Delta V_K \sin \theta_K - V_K \cos \theta_K \Delta \theta_y$$

When $V_K = 6000 \text{ ft/sec}$, $\theta_K = 30 \text{ deg}$, it follows that

$$\Delta V_T = \Delta V_K (0.866) \oplus 6000 (0.5) \Delta \theta_y = 65.3 \text{ ft/sec}$$

$$\Delta V_N = \Delta V_K (0.5) \oplus 6000 (0.866) \Delta \theta_y = 93.4 \text{ ft/sec}$$

where \oplus indicates a quadrature sum. The position error introduced during the apogee burn is estimated as

$$\Delta P_N \cong V_K \Delta T$$

where ΔT is the variation in burning time during the apogee burn. If one assumes that the thrust acceleration is 40-50 ft/sec², then 120-150 sec will be needed to obtain $V_K = 6000$ ft/sec. When $\Delta T \approx 4$ percent, then

$$\begin{aligned}\Delta P_N &\approx 6000 \times 5 \\ &\approx 5 \text{ nmi}\end{aligned}$$

The value for ΔV_N results in an inclination error of

$$\Delta i = \frac{93.4 (57.3)}{10080} = 0.531 \text{ deg}$$

and the contribution from the position error ΔP_N is negligible. The apogee burn will also be controlled in the orbit plane such that radial velocity errors are reduced. The pitch altitude θ_p should be chosen such that

$$\Delta V_R = V_K \sin \theta_p$$

where

$$\Delta V_R = 356 \text{ ft/sec}$$

An error of

$$\Delta V'_R \approx V_K \Delta \theta_p$$

will remain, and when $\Delta \theta_p = 1.0$ deg,

$$\begin{aligned}\Delta V'_R &\approx 6000 \Delta \theta_p \\ &\approx 100 \text{ ft/sec}\end{aligned}$$

The errors after the guided apogee burn may be summarized as

$$\Delta V_T = 123 \oplus 65.3 + V_D = 139.6 + V_D \text{ ft/sec}$$

$$\Delta V_N = 93.4$$

$$\Delta V_R \approx 100$$

$$\Delta P_T \approx \text{Not applicable}$$

$$\Delta P_N \approx 5 \text{ nmi}$$

$$\Delta P_R \approx 582 \text{ nmi}$$

$$\Delta i \approx 0.531 \text{ deg}$$

where V_D is a velocity decrement that was targeted into the nominal orbit to permit the payload to "walk" to the desired longitude.

The payload on-board hydrazine propellant system may then be used to circularize the orbit. The cost in ΔV , when it is assumed that the insertion was biased to ensure that the orbit perigee exceeds the desired value, is

$$\begin{aligned} \Delta V &= \Delta V_T + \omega \Delta P_R \\ &= V_D + \Delta V_T \oplus 7.4 \times 10^{-5} (582) (6076) \\ &= V_D + 139.6 \oplus 257.1 \\ &= V_D + 292.6 \end{aligned}$$

The results of the above calculation show that a correction velocity of about

$$\Delta V = 343 \text{ ft/sec } (3\sigma)$$

will circularize the resulting orbit when $V_D \approx 50 \text{ ft/sec}$. In general, ΔV will be lower than this because ΔV_T and ΔP_R are correlated. (The correlation coefficient is -0.868 .)

$$\Delta V \cong 50 + (257.1 - 123) \oplus 65.4 \cong 200 \text{ ft/sec}$$

3.4.10 Dynamic Error Sources

When the thrust vector of the spinning stage does not pass through the C.G., an offsetting moment M will occur. In addition, tip-off rates ω_r may be introduced during deployment. The offsetting moment and tip-off rates are assumed to cause equal coning and heading (bias) attitude errors. When transient effects are ignored, both of these effects may be conservatively approximated as:

$$\theta_M = \frac{57.3 M}{I_R \omega_o^2}$$

$$\theta_r = \frac{\omega_r I_T}{I_R \omega_o}$$

where

M = Offsetting Moment

I_T = Transverse Moment of Inertia

I_R = Roll Moment of Inertia

ω_o = SSUS Spin Rate = 100 rpm for EO-57A, EO-58A
= 45 rpm for AS-05A, EO-07A, EO-09A

ω_r = Tip-off Rate = 0.1 deg/sec

The effect of the coning error is to effect the magnitude of the ΔV that will result when the motor is fired. That is, this will appear as a $1 - \cos \theta$ effect. Heading errors will appear as bias offsets. It is assumed herein that each of these effects is equal, as a first approximation.

The magnitude of the heading and coning errors that result from the error sources is payload dependent. The following variables require specification:

- o C.G. Location
- o Vehicle Thrust
- o Moment of Inertia (pitch, yaw, roll)
- o Spin Rate
- o Jet Damping (ignored in this analysis)

In general, these variables are different for each of the payloads; hence, error analyses will be payload dependent. The required data for the various payloads must be assembled and the resultant coning and heading errors estimated for each of the two burns.

Computation of the offsetting moment requires definition of several propulsion parameters noted in the figure below.

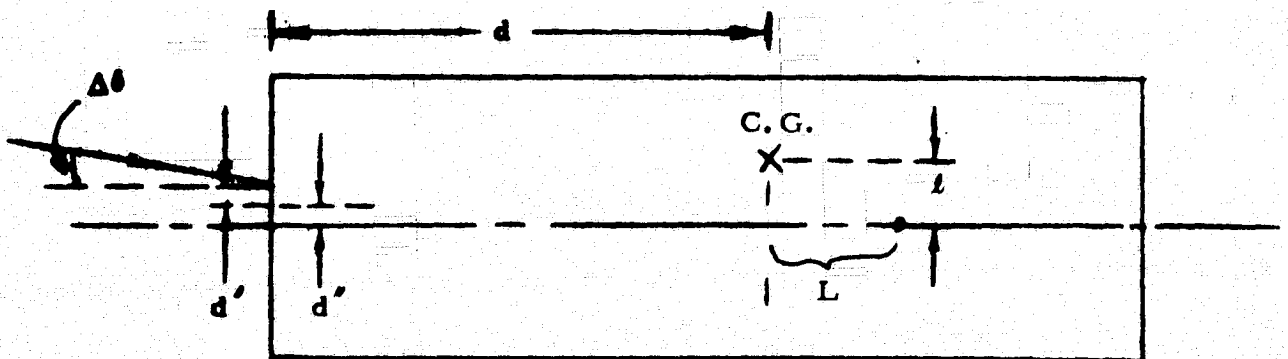

- | | |
|--------------------------------------|-------------------|
| $\Delta\delta$ = Thrust Misalignment | ≤ 0.115 deg |
| d' = Thrust Vector Offset | ≈ 0.1 in. |

- d'' = Thrust Chamber Flange Offset (can be shimmed) \approx assumed negligible
 l = Lateral C.G. Error ≈ 0.1 in.
 L = Longitudinal C.G. Error \approx not significant for this analysis

The moment M is then computed using the following equation:

$$M = F \sqrt{d^2 \frac{\Delta\delta^2}{57.3^2} + \frac{d'^2 + l^2}{(12)^2}}$$

$$\frac{F}{500} \sqrt{d^2 + (5.895)^2}$$

Preliminary values for the parameters shown in the previous figure were used to compute the results shown in Table 3-23.

A more detailed analysis of the dynamic effects has been performed for each of the payloads in the study. The burns were simulated in detail in order to determine precise values for the attitude errors that result from the offsetting moment. The results for θ_M are also included in Table 3-23. Note that these values do agree well with the formula results. It is recommended, however, that the simulated results be used in the error calculations. Note that the formula result for the "initial" value provides the closest approximation to the simulated result.

It is shown in Table 3-23 that the Spec value of 1.0 deg assumed for $\Delta\theta$ at the perigee burn can be met for all payloads studied. A Spec value of 1.0 deg was assumed for the attitude error developed during the apogee burn.

Table 3-23. Coning and Heading Errors (assumed equal) Resulting from Offsetting Moment (θ_M) and Tip-Off Rates (θ_r) During the Initial and Final Phases of Each Burn

	PAYLOAD DESIGNATION							
	EO-57A		AS-05A		EO-07A		EO-09A	
	Initial	Final	Initial	Final	Initial	Final	Initial	Final
Perigee Burn								
Moment, M	242.6	335.0	238.5	321.2	646.0	885.4	667.0	938.0
Formula Results:								
θ_M , deg	0.453	1.129	0.696	3.188	0.756	1.784	0.408	0.932
θ_r , deg	0.159	0.109	0.122	0.168	0.102	0.072	0.138	0.114
Ref. 6 Results:								
θ_M , deg		0.337		0.742		0.602		0.450
Apogee Burn								
Moment, M	106.3	139.3	152.4	194.3	259.0	323.6	242.6	323.5
Formula Results:								
θ_M , deg	0.529	0.808	1.968	3.172	0.660	0.968	0.284	0.448
Ref. 6 Results:								
θ_M , deg		0.230		1.322		0.480		0.393

C-4

Table 3-22

This Computer Run includes the following error analysis results:

Coast Orbit Errors for:

- EO-57A
- AS-05A
- EO-07A
- EO-09A
- Spec Case

Apogee Errors (unguided) for:

- EO-57A
- AS-05A
- EO-07A
- EO-09A
- Spec Case

The following information is included for each of the 10 cases listed above:

- Listing of Error Sources (35)
- Deviations of Dispersed Cases from Nominal
- RSS of Errors
- Covariance Matrix

THE INPUT FOR THIS RUN CONSISTS OF A 11 DIMENSIONAL NOMINAL AND 8 DISPERSED CASES. THE PROGRAM WILL FORM THE 11 BY 11 COVARIANCE MATRIX OF THE DISPERSIONS RELATIVE TO THE NOMINAL.

THE VARIABLES FOR THIS RUN ARE

- (1) VT
- (2) VR
- (3) VN
- (4) FT
- (5) FS
- (6) FN
- (7) H-APG
- (8) H-PEY
- (9) I
- (10) E(-2)
- (11) INCL

ORIGINAL PAGE IS OF POOR QUALITY

RUN NUMBER	IS	THIS CASE	UNIT SCALING
1	IS	RADIUS (FEET) = 500.000	(4500.000)
2	IS	TANG VEL (FPS) = 1.000	(10.000)
3	IS	RAD VEL (FPS) = 5.000	(40.000)
4	IS	WGN VEL (FPS) = 2.000	(40.000)
5	IS	TIME K1 (MIN) = .950	(.130)
6	IS	VEL K1 (FPS) = 60.000	(60.000)
7	IS	ATTN K1 (DEG) = .400	(3.000)
8	IS	ATTN K1 (DEG) = .430	(3.000)

THE NOMINAL CONDITIONS ARE AS FOLLOWS.

	VT	VR	VN	FT	FS	FN	PN
(1)	0.	0.	0.	0.	0.	0.	0.

THE DEVIATIONS OF THE DISPERSED CASES FROM NOMINAL

	VT	VR	VN	PT	PR	PN
(1)	-.3444444E+00	-.5555555E+00	.2777777E+00	-.2333333E+00	.1555556E+00	0.
(2)	-.6500000E+00	-.2000000E+01	.9000000E-01	-.1200000E+00	.2800000E+00	0.
(3)	-.4362500E+01	-.4000000E+00	.1325000E+01	-.1575000E+01	.7125000E+00	-.2500000E-01
(4)	0.	0.	-.9500000E-01	-.5000000E-02	0.	.3250000E+00
(5)	-.6333333E+01	-.8333333E+00	-.1000000E+02	.1116667E+02	.1333333E+01	-.1666667E+00
(6)	.6000000E+02	.8000000E+00	0.	0.	0.	0.
(7)	-.6000000E+00	0.	-.6000000E+02	0.	0.	0.
(8)	-.2560000E+00	-.6075200E+02	0.	0.	0.	0.

	H-APG	H-FGY	T	E(-3)	INCL
(1)	.3755556E+01	.1555556E+00	.1555556E+00	.5000000E-01	0.
(2)	.6650000E+01	.2200000E+00	.2500000E+00	.6700000E-01	0.
(3)	-.1046750E+02	.6675000E+00	-.3625000E+00	-.1525000E+00	0.
(4)	.1000000E-01	0.	0.	0.	-.1000000E-02
(5)	-.2033333E+02	.1333333E+01	-.8333333E+00	-.3000000E+00	0.
(6)	.5566000E+03	.3000000E+00	.2170000E+02	.6410000E+01	0.
(7)	-.5664000E+01	0.	-.2000000E+00	-.6720000E-01	-.1067200E+00
(8)	-.1760000E+00	-.2096000E+01	-.8000000E-01	.1392000E+00	0.

THE RSS OF THE ERRORS GIVFS THE FCLLOWING

	VT	VR	VN	PT	FR	PN
(1)	.6874886E+02	.E880048E+02	.6163188E+02	.1128025E+02	.1545326E+01	.3668980E+00

	F-AFG	H-FGY	T	E(-3)	INCL
(1)	.5971143E+03	.2E8879E+01	.2172216E+02	.6421233E+01	.1067247E+00

THE COVARIANCE MATRIX, WITH CORRELATION COEFFICIENTS BELOW THE DIAGONAL, IS BELOW.

	VT	VR	VN	PT	PR	PN
VT	.3689452E+04	.7374631E+02	.1142652E+03	-.8612625E+02	-.1445497E+02	.1497951E+01
VR	.1996884E-01	.3696889E+04	.7467212E+01	-.8313526E+01	-.2048131E+01	.1488889E+00
VN	.3054975E-01	.1992722E-02	.3791488E+04	-.1138287E+03	-.1232086E+02	.1605917E+01
PT	-.1295543E+00	-.1210703E-01	-.1637299E+00	.1212439E+03	.1369681E+02	-.1823361E+01
PR	-.1539984E+00	-.2179873E-01	-.1293647E+00	.7897433E+00	.2388032E+01	-.2400347E+00
PN	.6738268E-01	.6888957E-02	.7117381E-01	-.4415265E+00	-.4242840E+00	.1340278E+00
H-AFG	.9928268E+00	.1399579E-01	.1454975E-01	-.3150606E-01	-.3482823E-01	.1671677E-01
H-FCY	.2669139E-01	.7921988E+00	-.7686659E-01	.4670046E+00	.5837479E+00	-.2506632E+00
T	.9932046E+00	.1701212E-01	.1538113E-01	-.3591751E-01	-.3798862E-01	.1860453E-01
E(-3)	.9940479E+00	-.9147248E-02	.1744427E-01	-.4320566E-01	-.4898646E-01	.2289113E-01
INCL	.1000930E-01	0.	.9864721E+00	.4153236E-05	0.	-.8318041E-02

	H-AFG	H-FCY	T	E(-3)	INCL
VT	.3600907E+05	.4229666E+01	.1310457E+04	.3877097E+03	.6488576E-01
VR	.4935924E+03	.1256593E+03	.2248318E+02	-.3110796E+01	0.
VN	.9354495E+03	-.1235939E+02	.2054513E+02	.6913616E+01	.6488661E+01
PT	-.2122121E+03	.1374338E+02	-.6801914E+01	-.3129519E+01	.5000000E-05
PR	-.3213726E+02	.2353419E+01	-.1275195E+01	-.4221185E+00	0.
PN	.3654326E+01	-.2394097E+00	.1479514E+00	.5381250E-01	-.3250000E-03
H-AFG	.3565454E+06	.1470748E+03	.1297041E+05	.3832895E+04	.6144521E+00
H-FCY	.9441196E-01	.6806248E+01	.5398548E+01	.1148911E+01	0.
T	.9999841E+00	.9522679E-01	.4718522E+03	.1394297E+03	.2219776E-01
E(-3)	.9998570E+00	.6858261E-01	.9998171E+00	.4123224E+02	.7171564E-02
INCL	.9489049E-02	0.	.9975055E-02	.1046482E-01	.1139016E-01

THE INPUT FOR THIS RUN CONSISTS OF A 11 DIMENSIONAL NOMINAL AND 8 DISPERSED CASES. THE PROGRAM WILL FORM THE 11 BY 11 COVARIANCE MATRIX OF THE DISPERSIONS RELATIVE TO THE NOMINAL.

THE VARIABLES FOR THIS RUN ARE

- (1) VT
- (2) VR
- (3) VN
- (4) FT
- (5) FR
- (6) FN
- (7) H-AFC
- (8) H-FCY
- (9) T
- (10) E(-3)
- (11) INCL

ORIGINAL PAGE IS
OF POOR QUALITY

SLN NUMBER	1	IS	DESCRIPTION	THIS CASE	UNIT SCALING
SLN NUMBER 1	1	IS	RADIUS (FEET) =	500.000	(100.000)
SLN NUMBER 2	1	IS	TANG VEL (FPS) =	1.500	(1.500)
SLN NUMBER 3	1	IS	RAO VEL (FPS) =	2.000	(40.000)
SLN NUMBER 4	1	IS	NORM VEL (FPS) =	2.000	(40.000)
SLN NUMBER 5	1	IS	TIME K1 (MIN) =	.050	(.030)
SLN NUMBER 6	1	IS	VEL K1 (FPS) =	60.000	(60.000)
SLN NUMBER 7	1	IS	ATTN K1 (DEC) =	.950	(3.000)
SLN NUMBER 8	1	IS	ATTN K1 (DEC) =	.950	(3.000)

THE NOMINAL CONDITIONS ARE AS FOLLOWS.

	VT	VR	VN	FT	FR	FN	PN
(1)	0.	0.	0.	0.	0.	0.	0.

THE DEVIATIONS OF THE DISPERSED CASES FROM NOMINAL

	VT	VR	VN	PT	PR	PN
(1)	-.3444444E+00	-.5555555E+00	.2777778E+00	-.2333333E+00	.1555556E+00	0.
(2)	-.6500000E+00	-.2020000E+01	.9000000E-01	-.1200000E+00	.2000000E+00	0.
(3)	-.4362500E+01	-.4000000E+00	.1325000E+01	-.1575000E+01	.7125000E+00	-.2500000E-01
(4)	0.	0.	-.8500000E-01	-.5000000E-02	0.	.3250000E+00
(5)	-.8333333E+01	-.8333333E+00	-.1000000E+02	.1116667E+02	.1333333E+01	-.1666667E+00
(6)	.6000000E+02	.8000000E+00	0.	0.	0.	0.
(7)	-.1203333E+01	0.	-.1203333E+03	0.	0.	0.
(8)	-.5066667E+00	-.1202383E+03	0.	0.	0.	0.

	H-AG	H-FG	T	E (-3)	INCL
(1)	.3755556E+01	.1555556E+00	.1555556E+00	.5000000E-01	0.
(2)	.6500000E+01	.2200000E+00	.2500000E+00	.6700000E-01	0.
(3)	-.1048750E+02	.6675000E+00	-.3625000E+00	-.1525000E+00	0.
(4)	.1000000E-01	0.	0.	0.	-.1000000E-02
(5)	-.2033333E+02	.1233333E+01	-.8333333E+00	-.3000000E+00	0.
(6)	.5966000E+03	.3000000E+00	.2170000E+02	.6410000E+01	0.
(7)	-.1121000E+02	0.	-.4116667E+00	-.1330000E+00	-.2112167E+00
(8)	-.2433333E+00	-.4148333E+01	-.1583333E+00	.2750000E+00	0.

THE RSS OF THE ERRORS GIVES THE FOLLOWING

	VT	VR	VN	PT	PR	PN
(1)	.6875131E+02	.1202628E+03	.1207558E+03	.112E025E+02	.1545326E+01	.3660980E+00

	H-APG	H-FGY	T	E(-3)	INCL
(1)	.5971927E+03	.4429639E+01	.2172549E+02	.6426658E+01	.2112190E+00

THE COVARIANCE MATRIX, WITH CORRELATION COEFFICIENTS BELOW THE DIAGONAL, IS BELOW.

	VT	VR	VN	PT	FR	PN
VT	.3691722E+04	.1191146E+03	.2222000E+03	-.8612625E+02	-.1445497E+02	.1497951E+01
VR	.1630339E-01	.1446314E+05	.7467212E+01	-.8313526E+01	-.2048131E+01	.1488889E+00
VN	.3028868E-01	.5141848E-03	.1458196E+05	-.1138287E+03	-.1232086E+02	.1605917E+01
PT	-.1255327E+00	-.6126863E-02	-.8356519E-01	.1272439E+03	.1369681E+02	-.1823361E+01
FR	-.1539719E+00	-.1102063E-01	-.6602571E-01	.7857433E+00	.2388032E+01	-.2400347E+00
PN	.6735110E-01	.3381688E-02	.3632601E-01	-.4415265E+00	-.4242840E+00	.1340278E+00
H-APG	.5928062E+00	.7306914E-02	.2135514E-01	-.3190192E-01	-.3482365E-01	.1671458E-01
H-FCY	.2153391E-01	.9331563E+00	-.2310578E-01	.2790469E+00	.3438040E+00	-.1476305E+00
T	.9932012E+00	.1402564E-01	.2191067E-01	-.3591200E-01	-.3798279E-01	.1860167E-01
E(-3)	.5930770E+00	-.3673340E-01	.2425364E-01	-.4316919E-01	-.4854538E-01	.2287181E-01
INCL	.1981731E-01	0.	.9964939E+00	.2098546E-05	0.	-.4202937E-02

	H-APG	H-FCY	T	E(-3)	INCL
VT	.3601925E+05	.5794912E+01	.1311885E+04	.3817250E+03	.2541641E+00
VR	.1247830E+03	.4971111E+03	.3664576E+02	-.2784978E+02	0.
VN	.1540015E+04	-.1235939E+02	.5745595E+02	.1812219E+02	.2541649E+02
PT	-.2122171E+03	.1374338E+02	-.8801914E+01	-.3129519E+01	.5000000E-05
FR	-.2213726E+02	.2353419E+01	-.1275195E+01	-.4821185E+00	0.
PN	.2654326E+01	-.2394097E+00	.1479514E+00	.5311250E-01	-.3250000E-03
H-APG	.2566391E+06	.1481909E+03	.1297388E+05	.3823934E+04	.2367729E+01
H-FCY	.1501433E-01	.1952178E+02	.5985687E+01	.2978082E+00	0.
T	.9499674E+00	.9115481E-01	.4719971E+03	.1394379E+03	.8695086E-01
E(-3)	.5989527E+00	.1146124E-01	.9986794E+00	.4130193E+02	.2809182E-01
INCL	.1977017E-01	0.	.1894834E-01	.2019482E-01	.4461346E-01

THE INPUT FOR THIS RUN CONSISTS OF A 11 DIMENSIONAL NOMINAL AND 8 DISPERSED CASES. THE PROGRAM WILL FORM THE 11 BY 11 COVARIANCE MATRIX OF THE DISPERSIONS RELATIVE TO THE NOMINAL.

THE VARIABLES FOR THIS RUN ARE

- (1) VT
- (2) VR
- (3) VN
- (4) FT
- (5) FR
- (6) FN
- (7) H-ACC
- (8) H-PCY
- (9) T
- (10) E(-3)
- (11) INCL

RUN NUMBER	IS	THIS CASE	UNIT SCALING
1	IS RADIUS (FEET)	500.000	(4500.000)
2	IS TANG VEL (FPS)	1.000	(10.000)
3	IS RAD VEL (FPS)	5.000	(40.000)
4	IS KCRM VEL (FPS)	2.000	(40.000)
5	IS TIME K1 (MIN)	.050	(.030)
6	IS VEL K1 (FPS)	60.000	(60.000)
7	IS ATTY K1 (CFG)	.690	(3.000)
8	IS ATTP K1 (CFG)	.690	(3.000)

THE NOMINAL CONDITIONS ARE AS FOLLOWS.

	VT	VR	VN	FT	FR	FN
(1)	0.	0.	0.	0.	0.	0.

THE DEVIATIONS OF THE DISPERSED CASES FROM NOMINAL

	VT	VR	VN	PT	PR	PN
(1)	-.3444444E+00	-.5555555E+00	.2777778E+00	-.2333333E+00	.1555556E+00	0.
(2)	-.6500000E+00	-.2020000E+01	.9000000E-01	-.1200000E+00	.2000000E+00	0.
(3)	-.4262500E+01	-.4000000E+00	.1325000E+01	-.1575000E+01	.7125000E+00	-.2500000E-01
(4)	0.	0.	-.8500000E-01	-.5000000E-02	0.	.3250000E+00
(5)	-.6233333E+01	-.2333333E+00	-.1000000E+02	.1116667E+02	.1333333E+01	-.1666667E+00
(6)	.6000000E+02	.8000000E+00	0.	0.	0.	0.
(7)	-.8740000E+00	0.	-.3740000E+02	0.	0.	0.
(8)	-.3620000E+00	-.6733100E+02	0.	0.	0.	0.

	H-L-G	H-FGY	T	E(-3)	INCL
(1)	.3755555E+01	.1555556E+00	.1555556E+00	.5000000E-01	0.
(2)	.6150000E+01	.2200000E+00	.2500000E+00	.6700000E-01	0.
(3)	-.1048750E+02	.6875000E+00	-.3625000E+00	-.1925000E+00	0.
(4)	.1000000E-01	0.	0.	0.	-.1000000E-02
(5)	-.2133333E+02	.1233333E+01	-.8333333E+00	-.3000000E+00	0.
(6)	.5566000E+03	.3000000E+00	.2170000E+02	.6410000E+01	0.
(7)	-.8142000E+01	0.	-.2990000E+00	-.9860000E-01	-.1534100E+00
(8)	-.2530000E+00	-.2013000E+01	-.1159000E+00	.2000000E+00	0.

THE RSS OF THE ERRORS GIVES THE FOLLOWING

	VT	VR	VN	PT	PR	PN
(1)	.60744E+02	.873E4E8E+02	.8798073E+02	.112E025E+02	.1545326E+01	.3660900E+00

	H-APG	H-FGY	T	E(-3)	INCL
(1)	.5971429E+03	.33898E7E+01	.2172338E+02	.6423217E+01	.1534133E+00

THE COVARIANCE MATRIX, WITH CORRELATION COEFFICIENTS BELOW THE DIAGONAL, IS BELOW.

	VT	VF	VN	PT	FR	PN
VT	.3689916E+04	.9033161E+02	.1537864E+03	-.8612625E+02	-.1445497E+02	.1497951E+01
VR	.1702141E-01	.7632997E+04	.7467212E+01	-.8313526E+01	-.2048131E+01	.1488889E+00
VN	.2877946E-01	.9714927E-03	.7740602E+04	-.1136287E+03	-.1232066E+02	.1605917E+01
PT	-.1125546E+00	-.8425741E-02	-.1141953E+00	.1212439E+03	.1369681E+02	-.1823361E+01
FR	-.1573887E+00	-.1917057E-01	-.9062197E-01	.7857433E+00	.2398032E+01	-.2400347E+00
FN	.6739845E-01	.4655100E-02	.4955837E-01	-.4415263E+00	-.4242940E+00	.1340278E+00
H-APG	.9928193E+00	.9979941E-02	.1718195E-01	-.3190455E-01	-.3482655E-01	.1671597E-01
H-FCY	.2331953E-01	.8828204E+00	-.4144066E-01	.3594118E+00	.4492587E+00	-.1929131E+00
T	.9932092E+00	.1456965E-01	.1781637E-01	-.3591550E-01	-.3798649E-01	.1860348E-01
E(-3)	.9929977E+00	-.2173897E-01	.1592623E-01	-.4319231E-01	-.4857146E-01	.2286406E-01
INCL	.1430779E-01	0.	.9937346E+00	.2889273E-05	0.	-.5736595E-02

	H-APG	H-FCY	T	E(-3)	INCL
VT	.2801272E+05	.4401874E+01	.1311613E+04	.3817153E+03	.1340403E+00
VR	.5049948E+03	.2814514E+03	.2765189E+02	-.1219905E+02	0.
VN	.9028891E+03	-.1235939E+02	.3405133E+02	.1126070E+02	.1340812E+02
PT	-.2128181E+03	.1374732E+02	-.8500314E+01	-.3129513E+01	.5000000E-05
FR	-.2713776E+02	.2753419E+01	-.1275195E+01	-.4821183E+00	0.
FN	.3854326E+01	-.2394697E+00	.1479514E+00	.5381250E-01	-.3250000E-03
H-APG	.3569797E+06	.1474682E+03	.1291168E+05	.3823275E+04	.1249054E+01
H-FCY	.7299102E-01	.1149120E+02	.5575363E+01	.8377272E+00	0.
T	.9999789E+00	.7571171E-01	.4710752E+03	.1394327E+03	.4536959E-01
E(-3)	.9997994E+00	.3847809E-01	.9992741E+00	.4125772E+02	.1481941E-01
INCL	.1763457E-01	0.	.1376368E-01	.1503987E-01	.2353563E-01

3-86

ORIGINAL PAGE IS
OF POOR QUALITY

THE INPUT FOR THIS RUN CONSISTS OF A 11 DIMENSIONAL NOMINAL AND 8 DISPERSED CASES. THE PROGRAM WILL FORM THE 11 BY 11 COVARIANCE MATRIX OF THE DISPERSIONS RELATIVE TO THE NOMINAL.

THE VARIABLES FOR THIS RUN ARE

- (1) VT
- (2) VR
- (3) VN
- (4) FT
- (5) FR
- (6) FN
- (7) H-ABG
- (8) H-FCY
- (9) T
- (10) F(-2)
- (11) INCL

RLN NUMBER	IS	THIS CASE	UNIT SCALING
1	TS	RADIUS (FEET) = 500.000	(4500.000)
2	TS	TANG VEL (FPS) = 1.000	(10.000)
3	TS	RAD VEL (FPS) = 5.000	(40.000)
4	TS	NORM VFL (FPS) = 2.000	(40.000)
5	TS	TIME K1 (MIN) = .050	(.030)
6	TS	VEL K1 (FPS) = 60.000	(60.000)
7	TS	ATTY K1 (CFG) = .570	(3.000)
8	TS	ATTF K1 (CFG) = .570	(7.000)

THE NOMINAL CONCENTERS ARE AS FOLLOWS.

	VT	VR	VN	FT	FR	FN
(1) 0.	0.	0.	0.	0.	0.	0.

THE DEVIATIONS OF THE DISPERSED CASES FROM NOMINAL

	VT	VR	VN	PT	PR	PN
(1)	-.3444444E+00	-.5555555E+00	.2777778E+00	-.2333333E+00	.1555556E+00	0.
(2)	-.6500000E+00	-.2020000E+01	.9000000E-01	-.1200000E+00	.2000000E+00	0.
(3)	-.4225000E+01	-.4000000E+00	.1325000E+01	-.1575000E+01	.1125000E+00	-.2500000E-01
(4)	0.	0.	-.8500000E-01	-.5100000E-02	0.	.3250000E+00
(5)	-.8333333E+01	-.8333333E+00	-.1000000E+02	.1116667E+02	.1333333E+01	-.1666667E+00
(6)	.6000000E+02	.2000000E+10	0.	0.	0.	0.
(7)	-.7220000E+00	0.	-.7220000E+02	0.	0.	0.
(8)	-.3040000E+00	-.7214300E+02	0.	0.	0.	0.

	H-BAG	H-FGY	T	E (-3)	INCL
(1)	.2155556E+01	.1555556E+00	.1555556E+00	.5000000E-01	0.
(2)	.6650000E+01	.2200000E+00	.2500000E+00	.6700000E-01	0.
(3)	-.1040750E+02	.6875000E+00	-.3625000E+00	-.1525000E+00	0.
(4)	.0000000E-01	0.	0.	0.	-.1000000E-02
(5)	-.7033333E+02	.1333333E+01	-.3333333E+00	-.3000000E+00	0.
(6)	.5566000E+03	.3000000E+00	.2170000E+02	.6410000E+01	0.
(7)	-.2726000E+01	0.	-.2470000E+00	-.7500000E-01	-.1267300E+00
(8)	-.2000000E+00	-.2489000E+01	-.9500000E-01	.1653000E+00	0.

THE RSS OF THE ERRORS GIVES THE FOLLOWING —

	VT	VR	VN	PT	PR	PN
(1)	.6174233E+02	.7216377E+02	.7290191E+02	.1124025E+02	.1545326E+01	.3660980E+00

	H-AFG	H-FGY	T	E(-3)	INCL
(1)	.5571253E+03	.2933966E+01	.2172253E+02	.6421996E+01	.1267339E+00

THE COVARIANCE MATRIX, WITH CORRELATION COEFFICIENTS BELOW THE DIAGONAL, IS BELOW.

	VT	VP	VN	FT	FR	FN
VT	.3689631E+04	.0012527E+02	.1295272E+03	-.8612625E+02	-.1445497E+02	.1497951E+01
VR	.1827421E-01	.5210496E+04	.7467212E+01	-.8313526E+01	-.2148131E+01	.1488889E+00
VA	.2925073E-01	.1418992E-02	.5314688E+04	-.1138287E+03	-.1232086E+02	.1605917E+01
FT	-.1295512E+00	-.1019775E-01	-.1384186E+00	.1272439E+03	.1369621E+02	-.1823361E+01
FR	-.1539947E+00	-.1836109E-01	-.1093660E+00	.7857433E+00	.2388032E+01	-.2400347E+00
FN	.6735108E-01	.5674110E-02	.6017093E-01	-.4415265E+00	-.4242340E+00	.1340278E+00
H-APG	.9928239E+00	.1155227E-01	.1954493E-01	-.3150548E-01	-.3482758E-01	.1671647E-01
H-AGY	.2466879E-01	.3399428E+03	-.5778339E-01	.4152599E+00	.5190680E+00	-.2228894E+00
T	.9932049E+00	.1560031E-01	.1626159E-01	-.3541674E-01	-.3798780E-01	.1860413E-01
E(-3)	.9930112E+00	-.1434379E-01	.1932520E-01	-.4320552E-01	-.4658083E-01	.2285841E-01
INCL	.1188590E-01	0.	.9903503E+00	.3497506E-03	0.	-.7004756E-02

	H-APG	H-AGY	T	E(-3)	INCL
VT	.3681040E+04	.4449748E+01	.1310517E+04	.3817119E+03	.9149906E-01
VR	.1895779E+03	.1778278E+03	.2448161E+02	-.6649356E+01	0.
VN	.6766995E+03	-.1235939E+02	.2575213E+02	.8579416E+01	.9149991E+01
FT	-.2122121E+03	.1374339E+02	-.8800914E+01	-.3129519E+03	.5100000E-05
FR	-.1212728E+02	.2393419E+01	-.1275195E+01	-.4821169E+00	0.
FN	.1654326E+01	-.3164897E+00	.1479514E+00	.5381250E-01	-.3250000E-03
H-APG	.9965566E+00	.1472261E+03	.1297089E+05	.3833041E+04	.8523760E+00
H-AGY	.2401545E-01	.7802163E+01	.5465323E+01	.1029242E+01	0.
T	.9999118E+00	.2575283E-01	.4718728E+03	.1394308E+03	.3130231E-01
E(-3)	.9965573E+00	.5462515E-01	.9954451E+00	.4124204E+02	.1011305E-01
INCL	.1121343E-01	0.	.1137028E-01	.1242566E-01	.1606149E-01

THE INPUT FOR THIS RUN CONSISTS OF A 11 DIMENSIONAL NOMINAL AND 8 DISPERSED CASES. THE PROGRAM WILL FORM THE 11 BY 11 COVARIANCE MATRIX OF THE DISPERSIONS RELATIVE TO THE NOMINAL.

THE VARIABLES FOR THIS RUN ARE

- (1) VT
- (2) VR
- (3) VN
- (4) PT
- (5) PR
- (6) PN
- (7) H-APG
- (8) H-PGY
- (9) T
- (10) E(-3)
- (11) INCL

		THIS		UNIT	
		CASE		SCALING	
RUN NUMBER	1	IS	RADIUS (FEET) =	50.000	(4500.000)
RUN NUMBER	2	IS	TANG VEL (FPS) =	1.000	(10.000)
RUN NUMBER	3	IS	RAD VEL (FPS) =	5.000	(40.000)
RUN NUMBER	4	IS	NORM VEL (FPS) =	2.000	(40.000)
RUN NUMBER	5	IS	TIME K1 (MIN) =	.003	(.030)
RUN NUMBER	6	IS	VEL K1 (FPS) =	60.000	(60.000)
RUN NUMBER	7	IS	ATTY K1 (DEG) =	1.000	(3.000)
RUN NUMBER	8	IS	ATYP K1 (DEG) =	1.000	(3.000)

THE NOMINAL CONDITIONS ARE AS FOLLOWS.

	VT	VR	VN	PT	PR	PN
(1) 0.	0.	0.	0.	0.	0.	0.

THE DEVIATIONS OF THE DISPERSED CASES FROM NOMINAL

	VT	VR	VN	PT	PR	PN
(1)	-.3444444E+00	-.5555555E+00	.2777778E+00	-.2333333E+00	.1555556E+00	0.
(2)	-.6500000E+00	-.2000000E+01	.9000000E-01	-.1200000E+00	.2000000E+00	0.
(3)	-.4362500E+01	-.4000000E+00	.1325000E+01	-.1575000E+01	.7125000E+00	-.2500000E-01
(4)	0.	0.	-.8500000E-01	-.5000000E-02	0.	.3250000E+00
(5)	-.1388333E+02	-.1388333E+01	-.1666000E+02	.1860367E+02	.2221333E+01	-.2776667E+00
(6)	.6000000E+02	.8000000E+00	0.	0.	0.	0.
(7)	-.1266667E+01	0.	-.1266667E+03	0.	0.	0.
(8)	-.5333333E+00	-.1265667E+03	0.	0.	0.	0.

	H-APG	H-PGY	T	E(-3)	INCL
(1)	.3755556E+01	.1555556E+00	.1555556E+00	.5000000E-01	0.
(2)	.6650000E+01	.2200000E+00	.2500000E+00	.6700000E-01	0.
(3)	-.1049750E+02	.6875000E+00	-.3625000E+00	-.1525000E+00	0.
(4)	.1000000E-01	0.	0.	0.	-.1000000E-02
(5)	-.3387533E+02	.2221333E+01	-.1388333E+01	-.4998000E+00	0.
(6)	.5966000E+03	.3000000E+00	.2170000E+02	.6410000E+01	0.
(7)	-.1180000E+02	0.	-.4333333E+00	-.1400000E+00	-.2223333E+00
(8)	-.3666667E+00	-.4366667E+01	-.1666667E+00	.2900000E+00	0.

3-92

ORIGINAL PART OF POOR QUALITY

THE RSS OF THE ERRORS GIVES THE FOLLOWING

	VT	VR	VN	PT	PR	PN
(1)	.6175928E+02	.1265948E+03	.1277648E+03	.1867206E+02	.2354692E+01	.4281925E+00

	H-APG	H-PGY	T	E(-3)	INCL
(1)	.5978184E+03	.4963693E+01	.2175434E+02	.6439864E+01	.2223356E+00

THE COVARIANCE MATRIX, WITH CORRELATION COEFFICIENTS BELOW THE DIAGONAL, IS BELOW.

	VT	VR	VN	PT	PR	PN
VT	.3814208E+04	.1380263E+03	.3858063E+03	-.2512516E+03	-.3418337E+02	.3964001E+01
VR	-.1765403E-01	.1602624E+05	.2226351E+02	-.2482606E+02	-.4020971E+01	.3954939E+00
VN	.4889403E-01	.1376470E-02	.1632385E+05	-.3120992E+03	-.3599494E+02	.4565177E+01
PT	-.2170785E+00	-.1050267E-01	-.1308245E+00	.3486459E+03	.4013286E+02	-.5127868E+01
PR	-.2350599E+00	-.1348904E-01	-.1196454E+00	.9127959E+00	.5544576E+01	-.6346027E+00
PN	.1498969E+00	.7296003E-02	.8344634E-01	-.6413654E+00	-.6294029E+00	.1833488E+00
H-APG	.9837693E+00	.7391498E-02	.2679721E-01	-.5512760E-01	-.5702621E-01	.3778281E-01
H-PGY	-.4471208E-01	.8737336E+00	-.5681954E-01	.4335254E+00	.4714303E+00	-.2982895E+00
T	.9849246E+00	.1450998E-01	.2792072E-01	-.6234258E-01	-.6340751E-01	.4235691E-01
E(-3)	.9360323E+00	-.3800606E-01	.3145143E-01	-.7549246E-01	-.7863024E-01	.5170997E-01
INCL	.2950953E-01	0.	.9913979E+00	.1204394E-05	0.	-.3413779E-02

	H-APG	H-PGY	T	E(-3)	INCL
VT	.3632158E+05	-.1370642E+02	.1323278E+04	.3921661E+03	.2816222E+00
VR	.5593936E+03	.5490247E+03	.3993549E+02	-.3098556E+02	0.
VN	.2046775E+04	-.3603347E+02	.7760392E+02	.2587786E+02	.2816231E+02
PT	-.6153619E+03	.4017944E+02	-.2532345E+02	-.9077632E+01	.5000000E-05
PR	-.8027455E+02	.5509963E+01	-.3248035E+01	-.1192341E+01	0.
PN	.9671488E+01	-.6339777E+00	.3945564E+00	.1425903E+00	-.3250000E-03
H-APG	.3573868E+06	.1001697E+03	.1300447E+05	.3844915E+04	.2623523E+01
H-PGY	.3375750E-01	.2463735E+02	.3903805E+01	-.5358817E+00	0.
T	.9999486E+00	.3689396E-01	.4732511E+03	.1398830E+03	.9634444E-01
E(-3)	.9987133E+00	-.1676468E-01	.9984873E+00	.4147185E+02	.3112667E-01
INCL	.1973816E-01	0.	.1991920E-01	.2173937E-01	.4943311E-01

THE INFLT FOR THIS RUN CONSISTS OF A 11 DIMENSIONAL NOMINAL AND 12 DISPERSED CASES. THE PROGRAM WILL FORM THE 11 BY 11 COVARIANCE MATRIX OF THE DISPERSIONS RELATIVE TO THE NOMINAL.

THE VARIABLES FOR THIS RUN ARE

- (1) VT
- (2) VR
- (3) VN
- (4) DPT
- (5) DPR
- (6) DPN
- (7) H-APG
- (8) H-FGY
- (9) K-FEF
- (10) E(-3)
- (11) INCL

				THIS	UNIT
RUN NUMBER	IS			CASE	SCALING
1	IS	RADIUS (FEET)	=	500.000	(4500.000)
2	IS	TANG VEL (FPS)	=	1.000	(10.000)
3	IS	EAD VEL (FPS)	=	5.000	(40.000)
4	IS	NORM VEL (FPS)	=	2.000	(40.000)
5	IS	TIME K1 (MIN)	=	.450	(.030)
6	IS	VEL K1 (FPS)	=	60.000	(60.000)
7	IS	ATTY K1 (DEG)	=	.480	(3.000)
8	IS	ATTP K1 (DEG)	=	.480	(3.000)
9	IS	TIME K2 (MIN)	=	.450	(1.000)
10	IS	VEL K2 (FPS)	=	45.000	(40.000)
11	IS	ATTY K2 (DEG)	=	.320	(.500)
12	IS	ATTP K2 (DEG)	=	.320	(.500)

THE NOMINAL CONDITIONS ARE AS FOLLOWS.

VT

VR

VN

DPT

DPR

DPN

THE DEVIATIONS OF THE DISPERSED CASES FROM NOMINAL

	VT	VF	VN	DPT	DFR	DPN
(1)	-.655555E+00	-.216666E+01	.377777E+00	-.525555E+01	.374444E+01	-.287777E+01
(2)	-.116000E+01	-.379000E+01	.670000E+00	-.912000E+01	.661000E+01	-.499600E+01
(3)	.240250E+01	.563750E+01	-.132500E+01	-.737500E+00	-.106600E+02	-.412500E+00
(4)	0.	0.	.200000E+00	.870000E+00	0.	-.161500E+01
(5)	.450000E+01	.916666E+01	-.266666E+01	.720000E+02	-.200333E+02	.393333E+02
(6)	-.106600E+03	-.329500E+03	.632600E+02	-.465000E+03	.586600E+03	-.255000E+03
(7)	.110400E+01	.320000E+01	.180960E+02	-.992000E+00	-.564800E+01	.129280E+02
(8)	-.167200E+01	.304000E+01	-.104000E+01	-.896000E+02	-.176600E+00	-.448800E+02
(9)	0.	.155500E+01	-.100000E-01	-.264000E+01	0.	.129500E+01
(10)	-.403875E+02	0.	-.199125E+02	0.	0.	0.
(11)	-.146560E+02	0.	.296320E+02	0.	0.	0.
(12)	+.640000E-01	-.329500E+02	-.128000E+00	0.	0.	0.

	I-APG	H-PGY	K-PER	E(-3)	INCL
(1)	.643333E+01	.263333E+01	.430000E+00	.830000E-01	.713333E-02
(2)	.145200E+02	.140000E+01	.755000E+00	.286300E+00	.124500E-01
(3)	.135000E+01	-.213125E+02	-.962500E+00	.492625E+00	.171250E-02
(4)	0.	0.	0.	0.	.402500E-02
(5)	-.121160E+02	-.266000E+02	-.183000E+01	.320000E+00	-.975000E-01
(6)	.141950E+04	-.708000E+02	.642400E+02	.319150E+02	.681400E+00
(7)	-.544000E+01	-.921600E+01	-.592000E+00	.127040E+00	.473600E-02
(8)	-.355200E+01	-.681500E+01	-.491200E+00	.718400E-01	.120320E+00
(9)	.225000E+01	-.225450E+00	0.	.990000E-02	-.322000E-02
(10)	-.493750E+02	-.315337E+03	-.1726125E+02	.588325E+01	.112500E-01

3-96

ORIGINAL PAGE IS
OF POOR QUALITY

(11)	- .1203200E+02	- .1192960E+03	- .6208000E+01	.2371840E+01	.7507200E-01
(12)	.6835200E+02	- .6918400E+02	- .3840000E-01	.3012480E+01	0.

THE RSS OF THE ERRORS GIVES THE FOLLOWING

	VT	VR	VN	DPT	DFR	DPN
(1)	.1150651E+03	.3313810E+03	.7487900E+02	.4789427E+03	.5811193E+03	.2629205E+03

	H-APG	H-PGY	K-PER	E(-3)	INCL
(1)	.1422167E+04	.3532256E+03	.6683430E+02	.3268631E+02	.7030713E+00

THE COVARIANCE MATRIX, WITH CORRELATION COEFFICIENTS BELOW THE DIAGONAL, IS BELOW.

	VT	VR	VN	DPT	DPR	DPN
VT	.1323997E+05	.3518803E+05	-.6364607E+04	.4999914E+05	-.6202438E+05	.2743290E+05
VR	.9228346E+00	.1098134E+06	-.2079440E+05	.1536425E+06	-.1916029E+06	.8430188E+05
VN	-.7336999E+00	-.8380284E+00	.5606865E+04	-.2969706E+05	.3666484E+05	-.1604158E+05
DPT	.9072677E+00	.9680557E+00	-.8280752E+00	.2233861E+06	-.2714723E+06	.1257476E+06
DPR	-.9275848E+00	-.9949678E+00	.8426058E+00	-.9753864E+00	.3376997E+06	-.1489448E+06
DPN	-.9067939E+00	.9675762E+00	-.8148220E+00	.9986000E+00	-.9748453E+00	.6912719E+05
H-APG	-.9121482E+00	-.9976523E+00	.8478436E+00	-.9701168E+00	.9976799E+00	-.9632221E+00
H-PGY	.5377732E+00	.2151444E+00	-.6783818E-01	.1868455E+00	-.1962685E+00	.1853426E+00
K-PER	-.7898492E+00	-.9569967E+00	.8420720E+00	-.9362330E+00	.9617890E+00	-.9356663E+00
E(-3)	-.9764755E+00	-.9795576E+00	.8052098E+00	-.9471409E+00	.9749953E+00	-.9459542E+00
INCL	-.9242303E+00	-.9661249E+00	.8651381E+00	-.9939129E+00	.9731958E+00	-.9924591E+00

	H-APG	H-PGY	K-PER	E(-3)	INCL
VT	-.1432655E+06	.2185740E+05	-.6374171E+04	-.3672575E+04	-.7476926E+02
VR	-.4741728E+06	.2513335E+05	-.2119524E+05	-.1661620E+05	-.2250421E+03
VN	.9028725E+05	-.1794279E+04	.4214137E+04	.1970766E+04	.4554544E+02
DPT	-.6607820E+06	.3160982E+05	-.2996767E+05	-.1432737E+05	-.3346812E+03
DPR	.8245314E+06	-.4027531E+05	.3735464E+05	.1851909E+05	.3976170E+03
DPN	-.3624395E+06	.1721296E+05	-.1644163E+05	-.8129437E+04	-.1834579E+03
H-APG	.2022559E+07	-.9914925E+05	.9213135E+05	.4519654E+05	.9667555E+03
H-PGY	-.1754732E+00	.1247705E+06	.1699438E+04	-.4627789E+04	-.5901626E+02
K-PER	.9632982E+00	.7198633E-01	.4466823E+04	.1933176E+04	.4324091E+02
E(-3)	.9722741E+00	-.4008222E+00	.8849243E+00	.1668335E+04	.2197420E+02
INCL	.9669667E+00	-.2376383E+00	.9202294E+00	.9561978E+00	.4943093E+00

THE DEVIATIONS OF THE DISPERSED CASES FROM NOMINAL

	VT	VR	VN	OPT	QER	QPN
(1)	-.655555E+00	-.216667E+01	.377777E+00	-.525556E+01	.374444E+01	-.287778E+01
(2)	-.116000E+01	-.790000E+01	.670000E+00	-.912000E+01	.661000E+01	-.499000E+01
(3)	.246250E+01	.563750E+01	-.132500E+01	-.737500E+00	-.106000E+02	-.412500E+00
(4)	0.	0.	.200000E+00	.870000E+00	0.	-.161500E+01
(5)	.450000E+01	.916667E+01	-.266667E+01	.720000E+02	-.200333E+02	.393333E+02
(6)	-.106600E+03	-.329500E+03	.632000E+02	-.465000E+03	.580600E+03	-.255000E+03
(7)	.218500E+01	.633333E+01	.358150E+02	-.196333E+01	-.111783E+02	.255000E+02
(8)	-.212166E+01	.601667E+01	.205833E+01	-.175433E+03	-.348333E+00	-.959500E+02
(9)	0.	.155500E+01	-.100000E-01	-.264000E+01	0.	.129500E+01
(10)	-.403975E+02	0.	-.199125E+02	0.	0.	0.
(11)	-.622800E+02	0.	.125936E+03	0.	0.	0.
(12)	-.272000E+01	-.140000E+03	-.540000E+00	0.	0.	0.

	4-APG	H-PGY	K-PER	E(-3)	INCL
(1)	.643333E+01	.263333E+01	.430000E+00	.830000E-01	.713333E-02
(2)	.145200E+02	.140000E+01	.755000E+00	.286300E+00	.124500E-01
(3)	.105000E+01	-.213125E+02	-.962500E+00	.492625E+00	.171250E-02
(4)	0.	0.	0.	0.	.402500E-02
(5)	-.120166E+02	-.266000E+02	-.183000E+01	.320000E+00	-.975000E-01
(6)	.141350E+04	-.708000E+02	.642400E+02	.319150E+02	.681400E+00
(7)	-.680833E+01	-.182400E+02	-.117166E+01	.251433E+00	.937333E-02
(8)	-.703300E+01	-.134900E+02	-.972166E+00	.142183E+00	.238133E+00
(9)	.225600E+00	-.225450E+00	0.	.990000E-02	-.322000E-02
(10)	-.493750E+02	-.315337E+03	-.172012E+02	.588425E+01	.112500E-01

(11)	-.5113600E+02	-.5070000E+03	-.2638400E+02	.1008032E+02	.3190560E+00
(12)	.2904960E+03	-.2940320E+03	-.1632000E+00	.1280304E+02	0.

THE RSS OF THE ERRORS GIVES THE FOLLOWING

	VI	VE	VN	DPT	DER	DPN
(1)	.1300459E+03	.3583382E+03	.1467902E+03	.5023035E+03	.5811995E+03	.2765336E+03

	H-AFG	H-PGY	K-PER	E(-3)	INCL
(1)	.1450799E+04	.6705578E+03	.7159714E+02	.3632199E+02	.7954661E+00

THE COVARIANCE MATRIX, WITH CORRELATION COEFFICIENTS BELOW THE DIAGONAL, IS BELOW.

	VT	VR	VN	DPT	DPR	DPN
VT	.1691194E+05	.3522482E+05	-.1371946E+05	.5627313E+05	-.6204202E+05	.2762614E+05
VR	.7558907E+00	.1284063E+06	-.2054427E+05	.1528472E+06	-.1916572E+06	.8399264E+05
VN	-.7186923E+00	-.3905715E+00	.2154737E+05	-.3001834E+05	.3636616E+05	-.1550622E+05
DPT	.7696141E+00	.8491772E+00	-.4071208E+00	.2523088E+06	-.2714105E+06	.1382457E+06
DPR	-.8208503E+00	-.9202519E+00	.4262605E+00	-.9296837E+00	.3377928E+06	-.1491330E+06
DPN	.7692022E+00	.8476182E+00	-.3819978E+00	.9952624E+00	-.9278986E+00	.7647083E+05
H-APG	-.7755921E+00	-.9784557E+00	.3937879E+00	-.9054705E+00	.9779252E+00	-.9023949E+00
H-PGY	.5935176E+00	.2661181E+00	-.6346144E+00	.9915850E-01	-.1029436E+00	.9015038E-01
K-PER	-.4856748E+00	-.8256740E+00	.9921640E-01	-.8297910E+00	.8979247E+00	-.8280456E+00
E(-3)	-.9437319E+00	-.9452177E+00	.5946125E+00	-.8137344E+00	.8771804E+00	-.8098967E+00
INCL	-.9477427E+00	-.7857715E+00	.7263819E+00	-.9155104E+00	.8597365E+00	-.9105436E+00

	H-APG	H-PGY	K-PER	E(-3)	INCL
VT	-.1403313E+06	.5175670E+05	-.4522078E+04	-.4268802E+04	-.9390337E+02
VR	-.5136722E+05	.6394457E+05	-.2118348E+05	-.1230253E+05	-.2239809E+03
VN	.8386227E+05	-.6246593E+05	.1042741E+04	.3170303E+04	.8411657E+02
DPT	-.6598536E+06	.3339891E+05	-.2983894E+05	-.1484631E+05	-.3658062E+03
DPR	.8245409E+06	-.4011997E+05	.3736464E+05	.1851796E+05	.3974772E+03
DPN	-.3620359E+05	.1782933E+05	-.1639449E+05	-.8134805E+04	-.2002951E+03
H-APG	.2104917E+07	-.1441814E+06	.9337207E+05	.4822092E+05	.9500493E+03
H-PGY	-.1432060E+00	.4496477E+06	.1440676E+05	-.1301657E+05	-.2143441E+03
K-PER	.8919058E+00	.3000792E+00	.5126151E+04	.1679645E+04	.3510840E+02
E(-3)	.9150792E+00	-.5344300E+00	.6458805E+00	.1319287E+04	.2543929E+02
INCL	.8232227E+00	-.4018404E+00	.6164442E+00	.8656242E+00	.6327602E+00

THE INPUT FOR THIS RUN CONSISTS OF A 11 DIMENSIONAL NOMINAL AND 12 DISPERSED CASES. THE PROGRAM WILL FORM THE 11 BY 11 COVARIANCE MATRIX OF THE DISPERSIONS RELATIVE TO THE NOMINAL.

THE VARIABLES FOR THIS RUN ARE

- (1) VT
- (2) VR
- (3) VN
- (4) OPT
- (5) DPR
- (6) CPN
- (7) H-APG
- (8) H-FGY
- (9) K-FEF
- (10) E(-3)
- (11) INCL

				THIS	UNIT
				CASE	SCALING
RUN NUMBER	1	IS	RADIUS (FEET) =	500.000	(4500.000)
RUN NUMBER	2	IS	TANG VEL (FPS) =	1.000	(10.000)
RUN NUMBER	3	IS	AC VEL (FPS) =	5.000	(40.000)
RUN NUMBER	4	IS	NORM VEL (FPS) =	2.000	(40.000)
RUN NUMBER	5	IS	TIME K1 (MIN) =	.050	(.030)
RUN NUMBER	6	IS	VEL K1 (FPS) =	60.000	(60.000)
RUN NUMBER	7	IS	ATTY K1 (DEG) =	.950	(3.000)
RUN NUMBER	8	IS	ATTY K2 (DEG) =	.950	(3.000)
RUN NUMBER	9	IS	TIME K2 (MIN) =	.050	(1.000)
RUN NUMBER	10	IS	VEL K2 (FPS) =	45.000	(40.000)
RUN NUMBER	11	IS	ATTY K2 (DEG) =	1.360	(1.000)
RUN NUMBER	12	IS	ATTY K2 (DEG) =	1.360	(.500)

THE NOMINAL CONDITIONS ARE AS FOLLOWS.

VT

VR

VN

OPT

DPR

CPN

THE INPUT FOR THIS RUN CONSISTS OF A 11 DIMENSIONAL NOMINAL AND 12 DISPERSED CASES. THE PROGRAM WILL FORM THE 11 BY 11 COVARIANCE MATRIX OF THE DISPERSIONS RELATIVE TO THE NOMINAL.

THE VARIABLES FOR THIS RUN ARE

- (1) VT
- (2) VR
- (3) VN
- (4) CPT
- (5) CPR
- (6) OPN
- (7) H-APG
- (8) H-PGY
- (9) K-FER
- (10) E(-3)
- (11) INCL

		THIS		UNIT	
		CASE		SCALING	
RUN NUMBER	1	IS	RADIUS (FEET) =	500.000	(4500.000)
RUN NUMBER	2	IS	TANG VEL (FPS) =	1.000	(10.000)
RUN NUMBER	3	IS	EAD VEL (FPS) =	5.000	(40.000)
RUN NUMBER	4	IS	NCRH VEL (FPS) =	2.000	(40.000)
RUN NUMBER	5	IS	TIME K1 (MIN) =	.050	(.030)
RUN NUMBER	6	IS	VEL K1 (FPS) =	60.000	(60.000)
RUN NUMBER	7	IS	ATTY K1 (DEG) =	.690	(3.000)
RUN NUMBER	8	IS	ATTP K1 (DEG) =	.690	(3.000)
RUN NUMBER	9	IS	TIME K2 (MIN) =	.050	(1.000)
RUN NUMBER	10	IS	VEL K2 (FPS) =	45.000	(40.000)
RUN NUMBER	11	IS	ATTY K2 (DEG) =	.520	(.500)
RUN NUMBER	12	IS	ATTF K2 (DEG) =	.520	(.500)

THE NOMINAL CONDITIONS ARE AS FOLLOWS.

VT VR VN OPT OPR OPN

THE DEVIATIONS OF THE DISPERSED CASES FROM NOMINAL

	VT	VR	VN	DPT	GER	OPN
(1)	-. 8555555E+00	-.2166667E+01	.3777778E+00	-.5255556E+01	.3744444E+01	-.2877778E+01
(2)	-.1160000E+01	-.3790000E+01	.6700000E+00	-.9120000E+01	.6610000E+01	-.4990000E+01
(3)	.2462500E+01	.5637500E+01	-.1325000E+01	-.7375000E+00	-.1060000E+02	-.4125000E+00
(4)	0.	0.	.2000000E+00	.8700000E+00	0.	-.1615000E+01
(5)	.4500000E+01	.9166667E+01	-.2666667E+01	.7200000E+02	-.2003333E+02	.3933333E+02
(6)	-.1066000E+03	-.3295000E+03	.6320000E+02	-.4650000E+03	.5806000E+03	-.2550000E+03
(7)	.1587000E+01	.4600000E+01	.2601300E+02	-.1426000E+01	-.8119000E+01	.1858000E+02
(8)	-.1540000E+01	.4370000E+01	.1495000E+01	-.1274200E+03	-.2530000E+00	-.6969000E+02
(9)	0.	.1555000E+01	-.1000000E-01	-.2640000E+01	0.	.1295000E+01
(10)	-.4039750E+02	0.	-.1991250E+02	0.	0.	0.
(11)	-.2381600E+02	0.	.4815200E+02	0.	0.	0.
(12)	-.1040000E+00	-.5295000E+02	-.2080000E+00	0.	0.	0.

	4-APG	H-PGY	K-PER	E(-3)	INCL
(1)	.6433333E+01	.2633333E+01	.4300000E+00	.8300000E-01	.7133333E-02
(2)	.1452000E+02	.1400000E+01	.7550000E+00	.2863000E+00	.1245000E-01
(3)	.1050000E+01	-.2131250E+02	-.9625000E+00	.4926250E+00	.1712500E-02
(4)	0.	0.	0.	0.	.4025000E-02
(5)	-.1201667E+02	-.2660000E+02	-.1830000E+01	.3200000E+00	-.9750000E-01
(6)	.1419500E+04	-.7080000E+02	.6424000E+02	.3191500E+02	.6814000E+00
(7)	-.0945000E+01	-.1324800E+02	-.8510000E+00	.1826200E+00	.6808000E-02
(8)	-.5105000E+01	-.9790000E+01	-.7061000E+00	.1032700E+00	.1729600E+00
(9)	.2255000E+00	-.2254500E+00	0.	.9900000E-02	-.3220000E-02
(10)	-.4437500E+02	-.3153375E+03	-.1720125E+02	.5888250E+01	.1125000E-01

3-106

ORIGINAL PAGE
OF POOR QUALITY

(11)	-.195520E+02	-.193856E+03	-.100880E+02	.385424E+01	.121992E+00
(12)	.111072E+03	-.112424E+03	-.024000E-01	.489528E+01	0.

3-107

3-110

THE RSS OF THE ERRORS GIVES THE FOLLOWING

	VT	VR	VN	DPT	DER	DPN
(1)	.1165972E+03	.3340905E+03	.8601056E+02	.4876125E+03	.5811486E+03	.2679773E+03

	H-APG	H-PGY	K-PER	F(-3)	INCL
(1)	.1424952E+04	.3951100E+03	.6731037E+02	.3305353E+02	.7204200E+00

THE COVARIANCE MATRIX, WITH CORRELATION COEFFICIENTS BELOW THE DIAGONAL, IS BELOW.

	VT	VR	VN	DPT	DPR	DPN
VT	.1359491E+05	.3519179E+05	-.7056979E+04	.5009930E+05	-.6203083E+05	.2750354E+05
VR	.9034117E+00	.1116165E+06	-.2072235E+05	.1533518E+06	-.1916227E+06	.0418883E+05
VN	-.7036861E+00	-.7211460E+00	.7397316E+04	-.2981451E+05	.3655565E+05	-.1584587E+05
DPT	.8811883E+00	.9413474E+00	-.7108877E+00	.2377660E+06	-.2714497E+06	.1303165E+06
DPR	-.9154450E+00	-.9869511E+00	.7313337E+00	-.9579158E+00	.3377337E+06	-.1490136E+06
DPN	.9832431E+00	.9405563E+00	-.6674300E+00	.9973020E+00	-.9568432E+00	.7141181E+05
H-APG	-.9467049E+00	-.9954403E+00	.7312090E+00	-.9505174E+00	.9957058E+00	-.9487177E+00
H-PGY	.5368085E+00	.2187150E+00	-.2284845E+00	.1674648E+00	-.1751543E+00	.1646979E+00
K-PER	-.7549542E+00	-.9425908E+00	.6737094E+00	-.9116196E+00	.9550319E+00	-.9105619E+00
E(-3)	-.9678010E+00	-.9755101E+00	.7344377E+00	-.9203948E+00	.9640741E+00	-.9180145E+00
INCL	-.9131709E+00	-.9335134E+00	.7975520E+00	-.9851105E+00	.9495784E+00	-.9821533E+00

	H-APG	H-PGY	K-PER	E(-3)	INCL
VT	-.1489934E+05	.2473008E+05	-.5925032E+04	-.3729855E+04	-.7676634E+02
VR	-.4738922E+06	.2987093E+05	-.2119673E+05	-.1077243E+05	-.2246859E+03
VN	.8961764E+05	-.7764733E+04	.3900374E+04	.2087371E+04	.4941990E+02
DPT	-.6604426E+05	.3220386E+05	-.2992061E+05	-.1483429E+05	-.3460596E+03
DPR	.9245523E+06	-.4021853E+05	.3735830E+05	.1051891E+05	.3975659E+03
DPN	-.3622723E+06	.1743829E+05	-.1642439E+05	-.8131399E+04	-.1890131E+03
H-APG	.2030488E+07	-.9349301E+05	.9225362E+05	.4548680E+05	.9648005E+03
H-PGY	-.1664584E+00	.1561119E+06	.2928215E+04	-.5435718E+04	-.7463046E+02
K-PER	.9018305E+00	.1101040E+00	.4536685E+04	.1908711E+04	.4241029E+02
E(-3)	.9627500E+00	-.4162174E+00	.8579074E+00	.1092536E+04	-.2227018E+02
INCL	.9398233E+00	-.2621845E+00	.8745773E+00	.3354743E+00	.5190177E+00

THE INPUT FOR THIS RUN CONSISTS OF A 11 DIMENSIONAL NOMINAL AND 12 DISPERSED CASES. THE PROGRAM WILL FORM THE 11 BY 11 COVARIANCE MATRIX OF THE DISPERSIONS RELATIVE TO THE NOMINAL.

THE VARIABLES FOR THIS RUN ARE

- (1) VT
- (2) VR
- (3) VN
- (4) OPT
- (5) DPR
- (6) DPN
- (7) H-APG
- (8) H-FGY
- (9) K-FER
- (10) E(-3)
- (11) INCL

				THIS	UNIT
RUN	NUMBER	IS		CASE	SCALING
RUN	NUMBER	1	IS	RADIUS (FEET) =	500.000 (4500.000)
RUN	NUMBER	2	IS	TANG VEL (FPS) =	1.000 (10.000)
RUN	NUMBER	3	IS	RAD VEL (FPS) =	3.140 (40.000)
RUN	NUMBER	4	IS	NORM VEL (FPS) =	2.000 (40.000)
RUN	NUMBER	5	IS	TIME K1 (MIN) =	.050 (.030)
RUN	NUMBER	6	IS	VEL K1 (FPS) =	60.000 (60.000)
RUN	NUMBER	7	IS	ATTY K1 (DEG) =	.570 (3.000)
RUN	NUMBER	8	IS	ATTP K1 (DEG) =	.570 (3.000)
RUN	NUMBER	9	IS	TIME K2 (MIN) =	.350 (1.000)
RUN	NUMBER	10	IS	VEL K2 (FPS) =	45.000 (40.000)
RUN	NUMBER	11	IS	ATTY K2 (DEG) =	.450 (.500)
RUN	NUMBER	12	IS	ATTP K2 (DEG) =	.450 (.500)

THE NOMINAL CONDITIONS ARE AS FOLLOWS.

VT VR VN OPT DPR DPN

THE DEVIATIONS OF THE DISPERSED CASES FROM NOMINAL

	VT	VR	VN	DPT	CFR	DPN
(1)	-.6555555E+00	-.2166667E+01	.3777778E+00	-.5255556E+01	.3744444E+01	-.2877778E+01
(2)	-.1160000E+01	-.3790000E+01	.6700000E+00	-.9120000E+01	.6610000E+01	-.4990000E+01
(3)	.2462500E+01	.5637500E+01	-.1325000E+01	-.7375000E+00	-.1060000E+02	-.4125000E+00
(4)	0.	0.	.2000000E+00	.8700000E+00	0.	-.1615000E+01
(5)	.4500000E+01	.9166667E+01	-.2666667E+01	.7200000E+02	-.2003333E+02	.3933333E+02
(6)	-.1066000E+03	-.3295000E+03	.6320000E+02	-.4650000E+03	.5806000E+03	-.2550000E+03
(7)	.1311000E+01	.3900000E+01	.2148900E+02	-.1173000E+01	-.6707000E+01	.1535200E+02
(8)	-.1273000E+01	.3610000E+01	.1235000E+01	-.1052600E+03	-.2090000E+00	-.5757000E+02
(9)	0.	.1555000E+01	-.1000000E-01	-.2640000E+01	0.	.1295000E+01
(10)	-.4033750E+02	0.	-.1991250E+02	0.	0.	0.
(11)	-.2061000E+02	0.	.4167000E+02	0.	0.	0.
(12)	-.9000000E+01	-.4635000E+02	-.1800000E+00	0.	0.	0.

	H-APG	H-PGY	K-PER	E(-3)	INCL
(1)	.8433333E+01	.2633333E+01	.4300000E+00	.8300000E+01	.7133333E+02
(2)	.1452000E+02	.1400000E+01	.7550000E+00	.2863000E+00	.1245000E+01
(3)	.1050000E+01	-.2131250E+02	-.9625000E+00	.4926250E+00	.1712500E+02
(4)	0.	0.	0.	0.	.4025000E-02
(5)	-.1201667E+02	-.2660000E+02	-.1830000E+01	.3200000E+00	-.9750000E-01
(6)	.1414500E+04	.7080000E+02	.6424000E+02	.3191500E+02	.6814000E+00
(7)	-.4085000E+01	-.1094000E+02	-.7030000E+00	.1503600E+00	.5624000E+02
(8)	-.4219000E+01	-.8094000E+01	-.5833000E+00	.8531000E-01	.1428800E+00
(9)	.2256000E+01	-.2254500E+00	0.	.4900000E+02	-.3224000E+02
(10)	-.4437000E+02	-.3153375E+03	-.1720125E+02	.5388250E+01	.1125000E+01

(11)	-.1692000E+02	-.1677600E+03	-.8730000E+01	.3335400E+01	.1055700E+00
(12)	.9512000E+02	-.9729000E+02	-.5400000E-01	.4236300E+01	0.

THE COVARIANCE MATRIX, WITH CORRELATION COEFFICIENTS BELOW THE DIAGONAL, IS BELOW.

	VT	VR	VN	DPT	DPR	DPN
VT	.1345092E+05	.3519021E+05	-.6781394E+04	.5003766E+05	-.6282686E+05	.2746007E+05
VR	-.9111979E+00	.1108833E+06	-.2076523E+05	.1535307E+06	-.1916105E+06	.8425848E+05
VN	-.7197340E+00	-.7675958E+00	.659970E+04	-.2974223E+05	.3662285E+05	-.1596631E+05
DPT	-.8945562E+00	.9559800E+00	-.7590828E+00	.2326091E+06	-.2714636E+06	.1275048E+06
DPR	-.9203014E+00	-.9901761E+00	.7757242E+00	-.9685556E+00	.3377128E+06	-.1489713E+06
DPN	-.8938852E+00	.9552919E+00	-.7419755E+00	.9980892E+00	-.9677983E+00	.7015974E+05
H-APG	-.9028955E+00	-.9963351E+00	.7772257E+00	-.9620605E+00	.9965088E+00	-.9608044E+00
H-PGY	-.5366366E+00	.2172154E+00	-.1726758E+00	.174400E+00	-.1829077E+00	.1724627E+00
K-PER	-.7669066E+00	-.9483534E+00	.7390408E+00	-.9252142E+00	.9577501E+00	-.9244657E+00
E(-3)	-.9712807E+00	-.9771605E+00	.7631402E+00	-.9340579E+00	.9684652E+00	-.9327986E+00
INCL	-.9201552E+00	-.9498412E+00	.8274489E+00	-.9885197E+00	.9620444E+00	-.9864754E+00

	H-APG	H-PGY	K-PER	E(-3)	INCL
VT	-.1490974E+06	.2356909E+05	-.5985280E+04	-.3706719E+04	-.7589556E+02
VR	-.4723800E+05	.2739144E+05	-.2119535E+05	-.1070700E+05	-.2244359E+03
VN	.8990313E+05	-.5312513E+04	.4029715E+04	.2040366E+04	.4780648E+02
DPT	-.6606515E+06	.3186137E+05	-.2994957E+05	-.1483003E+05	-.3390575E+03
DPR	.8245347E+06	-.4025347E+05	.3735605E+05	.1851939E+05	.3975974E+03
DPN	-.3623561E+06	.1724963E+05	-.1643500E+05	-.8130192E+04	-.1858253E+03
H-APG	.2027278E+07	-.9134583E+05	.9220335E+05	.4536905E+05	.9656906E+03
H-PGY	-.1694083E+00	.1436152E+06	.2429601E+04	-.5108800E+04	-.6012517E+02
K-PER	.9648397E+00	.9558782E+01	.4504741E+04	.1918624E+04	.4275444E+02
E(-3)	.9683607E+00	-.4099704E+00	.8687324E+00	.1002774E+04	.2212055E+02
INCL	.9536889E+00	-.2529504E+00	.8958341E+00	.9466005E+00	.5057655E+00

3-114

ORIGINAL PAGE IS
OF POOR QUALITY

THE INPUT FOR THIS RUN CONSISTS OF A 11 DIMENSIONAL NOMINAL AND 12 DISPERSED CASES. THE PROGRAM WILL FORM THE 11 BY 11 COVARIANCE MATRIX OF THE DISPERSIONS RELATIVE TO THE NOMINAL.

THE VARIABLES FOR THIS RUN ARE

- (1) VT
- (2) VR
- (3) VN
- (4) DPT
- (5) DPR
- (6) DPN
- (7) H-APG
- (8) H-PGY
- (9) K-FER
- (10) E(-3)
- (11) INCL

RUN NUMBER	IS	DESCRIPTION	THIS CASE	UNIT SCALING
1	IS	RADIUS (FEET)	500.000	(4500.000)
2	IS	TANG VEL (FPS)	1.000	(10.000)
3	IS	RAD VEL (FPS)	5.000	(40.000)
4	IS	NORM VEL (FPS)	2.000	(40.000)
5	IS	TIME K1 (MIN)	.003	(.030)
6	IS	VEL K1 (FPS)	60.000	(60.000)
7	IS	ATTY K1 (DEG)	1.000	(3.000)
8	IS	ATTY K1 (DEG)	1.000	(3.000)
9	IS	TIME K2 (MIN)	.003	(1.000)
10	IS	VEL K2 (FPS)	5.000	(4.000)
11	IS	ATTY K2 (DEG)	1.000	(.500)
12	IS	ATTY K2 (DEG)	1.000	(.500)

THE NOMINAL CONDITIONS ARE AS FOLLOWS.

VT

VR

VN

DPT

DPR

DPN

THE DEVIATIONS OF THE DISPERSED CASES FROM NOMINAL

	VT	VR	VN	DPT	DFR	OPN
(1)	-.655555E+00	-.216667E+01	.377777E+00	-.525556E+01	.374444E+01	-.287777E+01
(2)	-.116000E+01	-.379000E+01	.670000E+00	-.912000E+01	.661000E+01	-.499000E+01
(3)	.246250E+01	.563750E+01	-.132500E+01	-.737500E+00	-.106000E+02	-.412500E+00
(4)	0.	0.	.200000E+00	.870000E+00	0.	-.161500E+01
(5)	.749700E+01	.152716E+02	-.444266E+01	.119952E+03	-.333755E+02	.655293E+02
(6)	-.106600E+03	-.329500E+03	.632000E+02	-.465000E+03	.580600E+03	-.255000E+03
(7)	.230000E+01	.666667E+01	.377000E+02	-.206667E+01	-.117667E+02	.269333E+02
(8)	-.223333E+01	.633333E+01	.216667E+01	-.184667E+03	-.366667E+00	-.101000E+03
(9)	0.	.259063E+01	-.166600E+01	-.439824E+01	0.	.215747E+01
(10)	-.403875E+02	0.	-.199125E+02	0.	0.	0.
(11)	-.456000E+02	0.	.926000E+02	0.	0.	0.
(12)	-.201000E+00	-.103000E+03	-.400000E+00	0.	0.	0.

	H-APG	H-PGY	K-PER	E (-3)	INCL
(1)	.643333E+01	.263333E+01	.430000E+00	.830000E+01	.713333E-02
(2)	.145200E+02	.148000E+01	.755000E+00	.286300E+00	.124500E-01
(3)	.105000E+01	-.213125E+02	-.962500E+00	.492625E+00	.171250E-02
(4)	0.	0.	0.	0.	.442500E-02
(5)	-.200197E+02	-.443156E+02	-.304878E+01	.533120E+00	-.162435E+00
(6)	.141950E+04	-.708000E+02	.642400E+02	.319150E+02	.681400E+00
(7)	-.716667E+01	-.192000E+02	-.123333E+01	.264667E+00	.986667E-02
(8)	-.740000E+01	-.142000E+02	-.102333E+01	.149667E+00	.250000E+00
(9)	.375849E+00	-.375599E+00	0.	.164934E-01	-.536452E-02
(10)	-.403750E+02	-.315337E+03	-.172012E+02	.588825E+01	.112500E-01

3-116

(11)	-.376000E+02	-.372000E+03	-.194000E+02	.741200E+01	.234600E+06
(12)	.213600E+03	-.216200E+03	-.120000E+00	.941400E+01	0.

THE RSS OF THE ERRORS GIVES THE FOLLOWING

	VT	VR	VN	DPT	DPR	DPN
(1)	.1231532E+03	.3457667E+03	.1200574E+03	.5140367E+03	.5810238E+03	.2033480E+03

	H-APG	H-PGY	K-PER	E(-3)	INCL
(1)	.1437052E+04	.5414518E+03	.6937276E+02	.3400503E+02	.7004100E+00

THE COVARIANCE MATRIX, WITH CORRELATION COEFFICIENTS BELOW THE DIAGONAL, IS BELOW.

	VT	VR	VN	DPT	DPR	DPN
VT	.1516671E+05	.3526668E+05	-.1012963E+05	.5008816E+05	-.6220465E+05	.2796845E+05
VR	.8205298E+00	.1195546E+06	-.2059686E+05	.1538964E+06	-.1919911E+06	.8459154E+05
VN	-.6651677E+00	-.4961683E+00	.1441378E+05	-.3040580E+05	.3641709E+05	-.1561481E+05
DPT	.8129162E+00	.8648577E+00	-.492117E+00	.2648510E+06	-.2739626E+05	.1450811E+06
DPR	-.8081317E+00	-.9543473E+00	.5213531E+00	-.9149534E+00	.3385189E+05	-.1505593E+06
DPN	.8014979E+00	.8634238E+00	-.4590159E+00	.9949238E+00	-.9132633E+00	.8028611E+05
H-APG	-.8354397E+00	-.9865235E+00	.5038114E+00	-.8941212E+00	.9867417E+00	-.8910439E+00
H-PGY	.5548754E+00	.2380692E+00	-.5100777E+00	.1485909E+00	-.1242781E+00	.1046839E+00
K-PER	-.6193801E+00	-.8848706E+00	.3089157E+00	-.8418131E+00	.9273743E+00	-.8401974E+00
E(-3)	-.9330046E+00	-.9588775E+00	.6233751E+00	-.8314996E+00	.9191337E+00	-.8274341E+00
INCL	-.8907095E+00	-.8353680E+00	.7066769E+00	-.9530489E+00	.8829759E+00	-.9476621E+00

	H-APG	H-PGY	K-PER	E(-3)	INCL
VT	-.1478541E+06	.3699994E+05	-.5291660E+04	-.3976245E+04	-.85606E8E+02
VR	-.4991685E+06	.4457036E+05	-.2122524E+05	-.1147323E+05	-.2254155E+03
VN	.8092195E+05	-.3315775E+05	.2572876E+04	.2589868E+04	.6621081E+02
DPT	-.6612562E+06	.3025896E+05	-.3005422E+05	-.1400819E+05	-.3827708E+03
DPR	.8251258E+06	-.3915127E+05	.3743119E+05	.1050587E+05	.4089250E+03
DPN	-.3628206E+06	.1606053E+05	-.1651545E+05	-.8113213E+04	-.2095543E+03
H-APG	.2105119E+07	-.1162648E+06	.9281476E+05	.4670217E+05	.9594348E+03
H-PGY	-.1494222E+00	.2931701E+06	.8330294E+04	-.895567E+04	-.1357983E+03
K-PER	.9311125E+00	.2217745E+00	.4812580E+04	.1801685E+04	.3926574E+02
E(-3)	.9399333E+00	-.4779637E+00	.7504997E+00	.1197508E+04	.2351042E+02
INCL	.8555001E+00	-.3213748E+00	.7252739E+00	.8705592E+00	.6090397E+00

ORIGINAL PAGE IS
OF POOR QUALITY

3.5 PARAMETRIC ATTITUDE ERROR ANALYSIS

3.5.1 Introduction

In support of the Spin-Stabilized Upper Stage (SSUS) for the Space Shuttle program and the Spin-Stabilized Upper Stage for the Global Positioning System, a parametric error analysis has been conducted. The error analysis was conducted in a parametric fashion as a function of configuration inertia ratios and spin rate. The intent of the analysis was to determine the estimated spin body attitude pointing errors due to various error sources. Specifically, the error sources considered were errors due to free spinup of the body, attitude or precession coning angles due to extended coast periods, attitude and coning angles due to transverse torques on the body during rocket motor thrusting, and finally determination of attitude error and coning angles when two spinning bodies are separated one from the other.

3.5.2 Summary

Results of the spinning body attitude error analysis have established that it is possible to determine in a parametric fashion the attitude and coning errors as a function of specific error sources (i.e., spinup, separation, long coast, and SRM thrusting). Presented in the following pages of this report is a discussion of the specific analysis and parametric plots of the results. The analysis was conducted utilizing appropriate information from Reference 1.* The specific equations were obtained from Reference 1 and were simplified in some cases to provide approximative and, hopefully, in all cases conservative results which would bound the expected errors. In addition, information was utilized based on unpublished data that has been collected over a period of time on several different programs of this type.

* H. I. Leon, Spin Dynamics of Rockets and Space Vehicles in Vacuum, STL-TR-59-0000-00787, TRW Systems Group, Redondo Beach, Calif. (6 September 1959).

The error analysis contained herein is to establish the body attitude error due to the significant error sources. It was not the intent to conduct an injection error analysis to establish orbital errors. The results of this analysis are only part of the required input for a total system injection error analysis and must be combined in a proper manner with a trajectory/orbit simulation to obtain final system errors.

3.5.3 Discussion

3.5.3.1 Attitude Pointing Errors Due to Free Spinup

From the data presented in Reference 1, it is possible to obtain a simplified equation for approximating the pointing attitude error of a spinning body due to free spinup which utilizes spin rockets. The resulting attitude error can be determined by the following equation:

$$\alpha_s \approx \omega_o(t_s) + 1/2 (\mu) \gamma \omega_s t_s$$

where:

ω_o = Initial tumble rate, rad/sec

t_s = Spinup time, sec

$\mu = I_s/I_t$ inertia ratio

γ = Misalignment of spin vector with spin axis, rad

ω_s = Spin rate, rad/sec

In addition, the spin axis/vector misalignment due to misalignments and uncertainties in the spin rockets can be determined by the following equation:

$$\gamma = \left[\beta^2 + \frac{1}{n} \delta_p^2 + \frac{1}{n} \left(\frac{1_s}{r_s} \delta_r \right)^2 + \frac{1}{n} \left(\frac{\delta_{1_s}}{r_s} \right)^2 + \frac{1}{n} \left(\frac{1_s}{r_s} \frac{\delta T_s}{T_s} \right)^2 \right]^{1/2}$$

δ_{l_s} = Longitudinal spin rocket location error = 0.1 in.

r_s = Spin moment arm = 48 in.

l_s = Longitudinal distance from c.g. to spin plane location \leq 3 in.

$\delta T_s / T_s$ = Spin rocket dispersion = 0.02

n = Number of spin nozzles = 6

δ_r = Spin nozzle misalignment in roll plane = 0.001 rad

δ_p = Spin nozzle misalignment in pitch plane = 0.001 rad

β = Misalignment of principal axis = 0.001 rad

Using the above equations, the resulting attitude error after spinup can be determined for typical spin rates and inertia ratios. The assumed input data for the equations was based on information obtained from typical spinup systems and test data. Presented in Figure 3-12 is the resulting attitude pointing error due to free spinup as a function of varying inertia ratios and spin rate.

In addition, the spinning body will have established a wobble (precession) half-cone angle as a result of transverse rates being introduced due to any asymmetrical torques during the spinup process. Using the appropriate equations from Reference 1 and simplifying where possible, the resulting wobble angle caused by free spinup can be determined by the following equation:

$$\theta_{\omega} \approx \tan^{-1} \left[\frac{\omega_o}{\mu \omega_s} + \frac{\gamma}{t_s} \left(\frac{\pi}{(\mu - 1) \dot{\omega}_s} \right) \right]^{1/2}$$

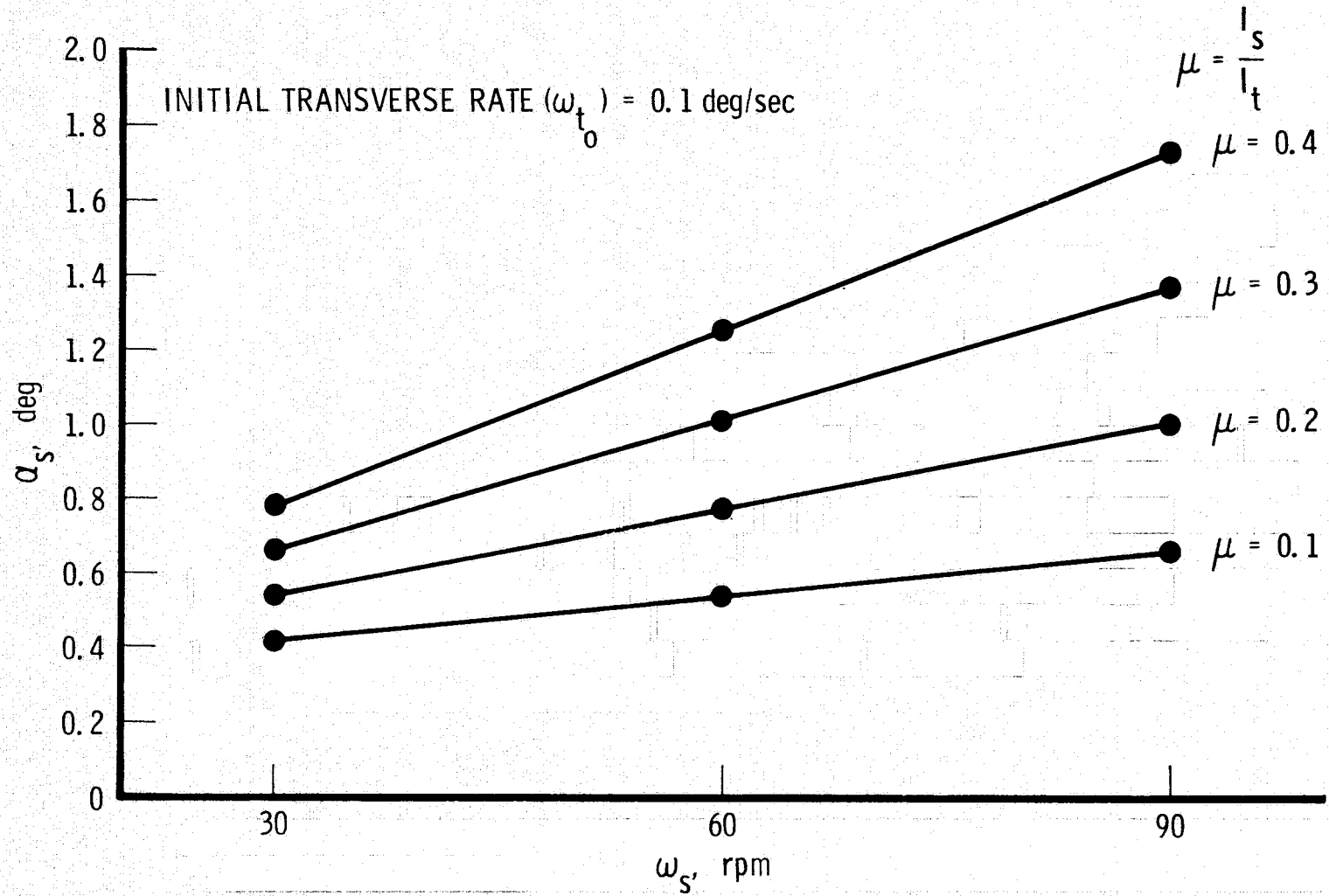

Figure 3-12. Attitude Pointing Error (α_s) Due to Free Spinup

where:

θ_{ω} = Wobble half angle

ω_o = Initial tumble rate, rad/sec

ω_s = Spin rate, rad/sec

$\mu = I_s / I_t$ inertia ratio

γ = Misalignment of spin axis and vector

t_s = Spinup time, sec

ω_s = Spin angular acceleration, = 3 rad/sec²

Presented in Figure 3-13 is the resulting free spinup wobble half angle as a function of inertia ratio and spin rate. It should be noted that the data presented in these two figures have been compared with typical analog computer results for a similar analysis on the GPS program and compare favorably.

3.5.3.2 Wobble Angle (Precession) Buildup During Coast While Spinning About an Axis of Minimum Inertia

The wobble angle buildup of a spinning body which is spinning about the axis of minimum inertia can be determined by the following equation:

$$\theta_{\omega_f} = \theta_{\omega_o} e^{t/\tau}$$

where:

θ_{ω_f} = Wobble half angle at the end of coast, deg

θ_{ω_o} = Initial wobble half angle at the start of coast, deg

t = Coast time, sec

τ = Total system divergent time constant, sec

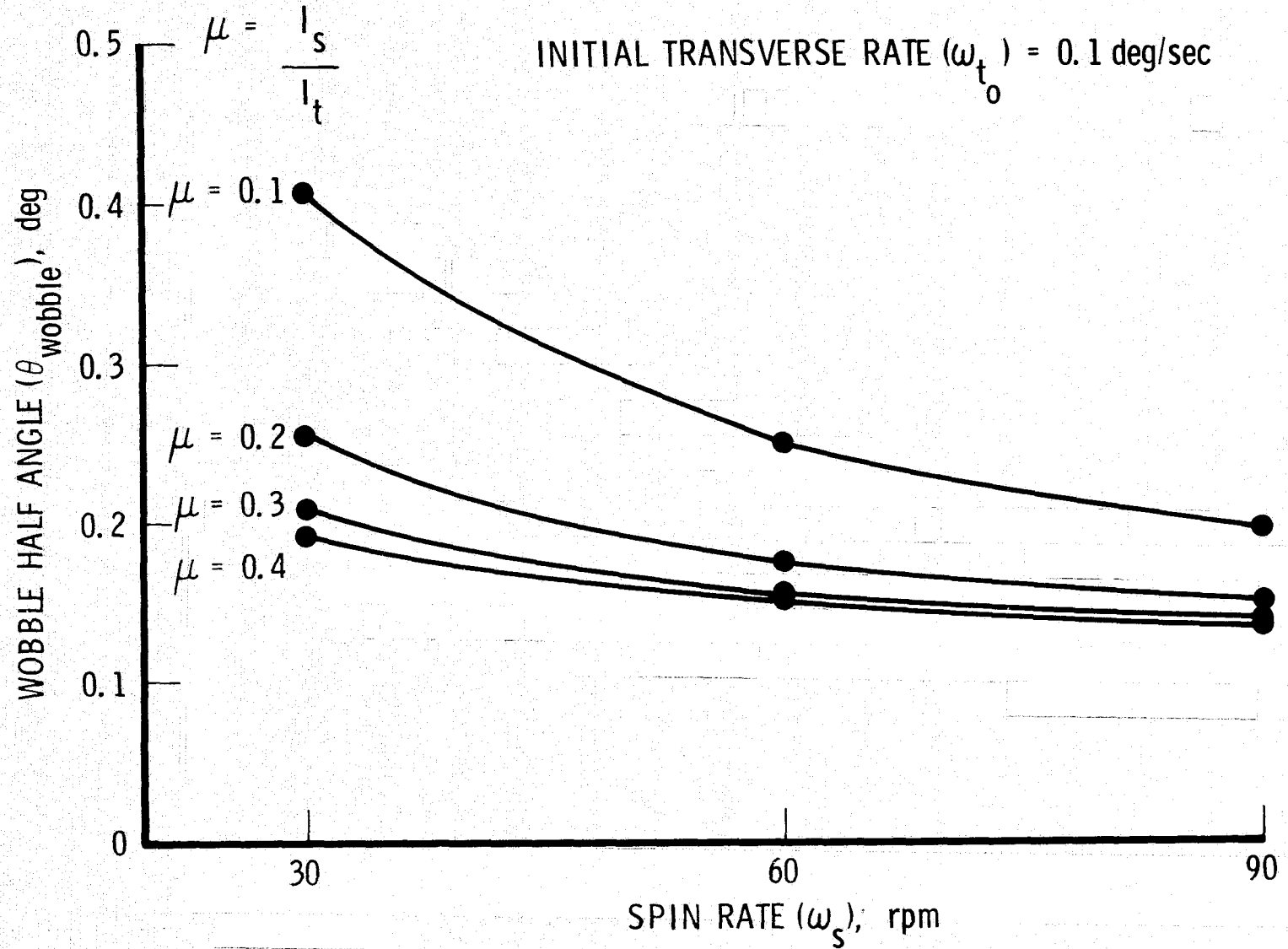

Figure 3-13. Wobble Angle Due to Free Spinup

The initial wobble half angle (θ_{ω_0}) is determined by:

$$\theta_{\omega_0} = \tan^{-1} \left[\left(\frac{1}{\mu} \right) \frac{\omega_t}{\omega_s} \right]$$

where:

$\mu = I_s / I_t$ inertia ratio

$\omega_t =$ Transverse angular rate, rad/sec

$\omega_s =$ Spin rate, rad/sec

If energy dissipation exists in the spinning body, there will be divergent time constants of the system which are related to the rate of energy dissipation. Since energy is dissipated by several sources, the total energy time constant becomes a sum of the energy time constants contributed from each source as defined in the following equation:

$$\frac{1}{\tau} = \frac{1}{\tau_1} + \frac{1}{\tau_2} + \dots + \frac{1}{\tau_n}$$

The rate of energy dissipation for several obvious sources in a spinning stage or spacecraft is presented in Figure 3-14. This data is based on analyses that have been conducted in the past and on some test data by spacecraft contractors. As indicated, the structural parts of the spinning stage or spacecraft have time constants that do not significantly contribute to energy dissipation. However, tanks which contain gas or liquids have significantly lower time constants.

Parametric calculations were conducted to determine final wobble (precession) half cone angles assuming a system time constant of 10,000 sec for various inertia ratios and spin rates. In addition, the initial wobble

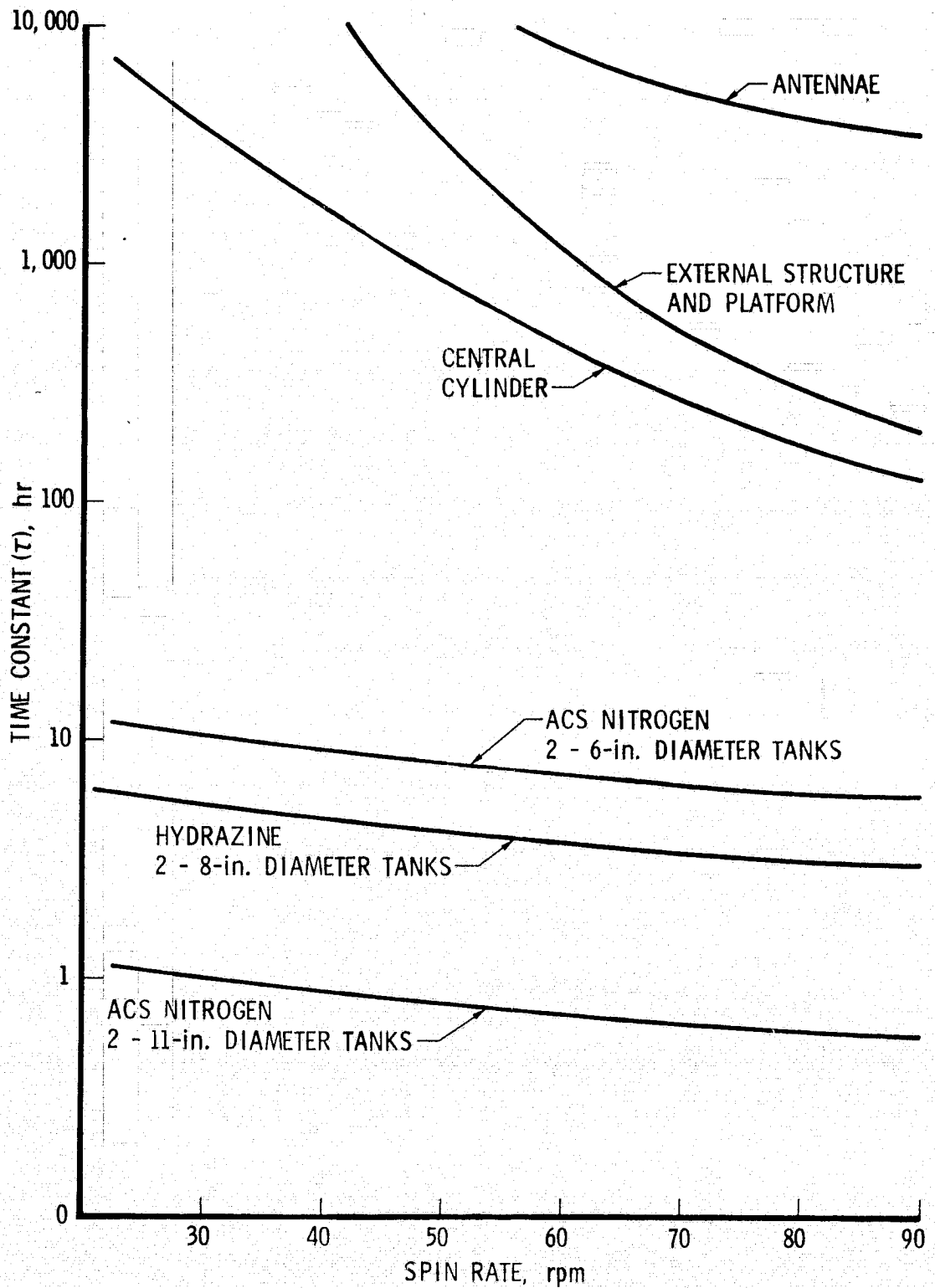

Figure 3-14. Estimated Time Constants of Structures and Fluids

half cone angle due to an initial transverse body rate of one deg/sec was determined as a function of inertia ratios and spin rate. It should be noted that if the initial transverse body rates of the configuration being investigated are a different value than one deg/sec, the resulting wobble half cone angles can be factored in a proportional manner.

Presented in Figure 3-15 is the initial body wobble angle at zero coast time, assuming an initial transverse rate of one deg/sec. Presented in Figure 3-16 is the final wobble half angle at the end of a one-hr coast, assuming a total system time constant of 10,000 sec and an initial transverse body rate of one deg/sec. Presented in Figure 3-17, based on the same analysis ground rules, is the final wobble half angle at the end of a 5.25-hr coast.

3.5.3.3 Attitude Pointing Errors of a Spinning Body Due to Thrusting of a Rocket Motor

During thrusting of a rocket contained in a spinning body, there will be existing thrust misalignments which will cause attitude errors of the spinning body at completion of the burn. Utilizing the appropriate equations from Reference 1 and simplifying where possible, the total effective attitude error at burnout of the rocket can be approximated by the following equation:

$$\alpha_B \approx \frac{T e}{I_s \omega_s^2} \left[1 + \frac{1}{(\mu - 1)} \right]^{RSS}$$

where:

T = Rocket thrust

e = Thrust vector offset, in.

I_s = Spin inertia, in-lb-sec²

ω_s = Spin rate, rad/sec

μ = I_s / I_t inertia ratio

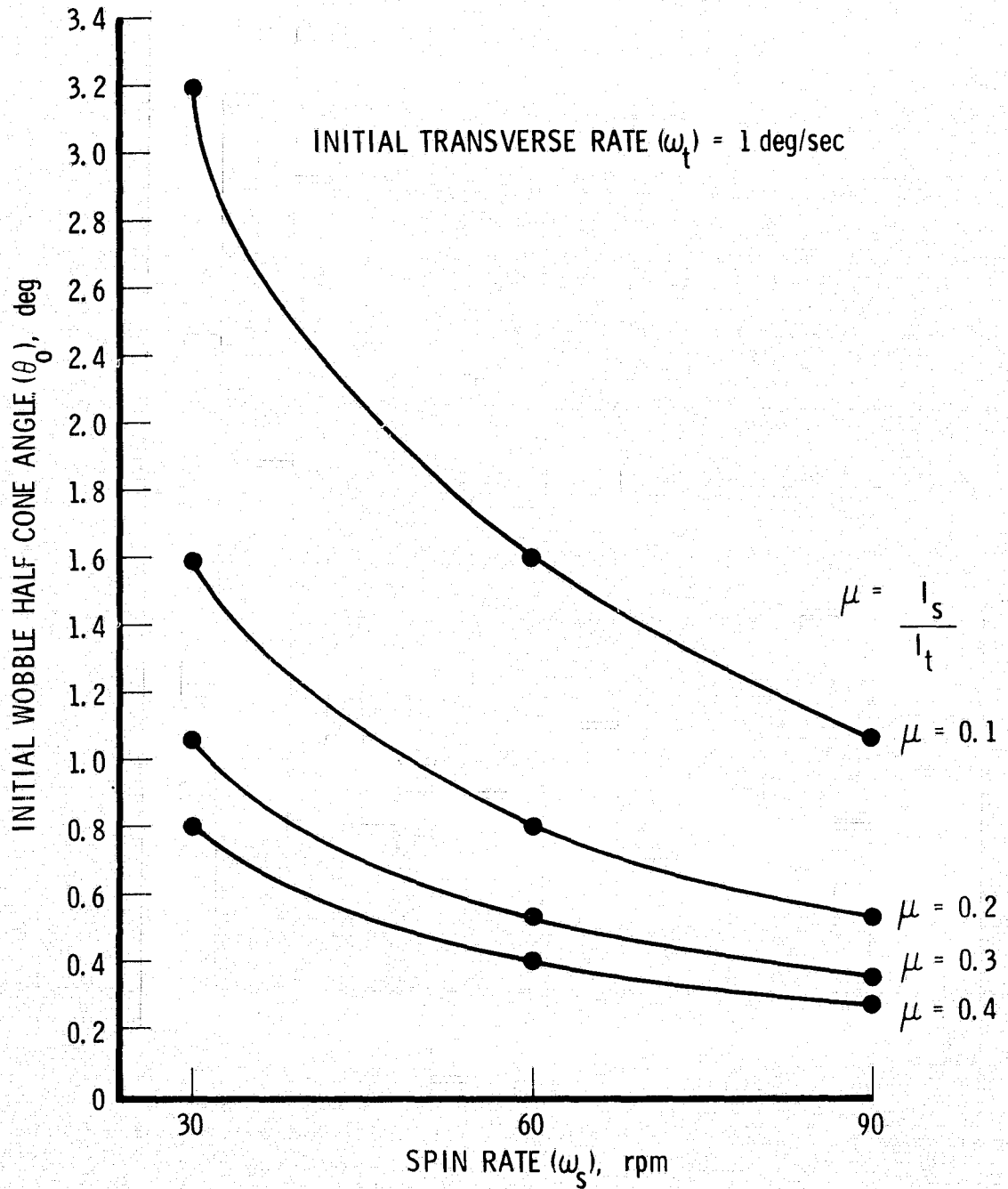

Figure 3-15. Initial Wobble Angle Due to Transverse Body Rate

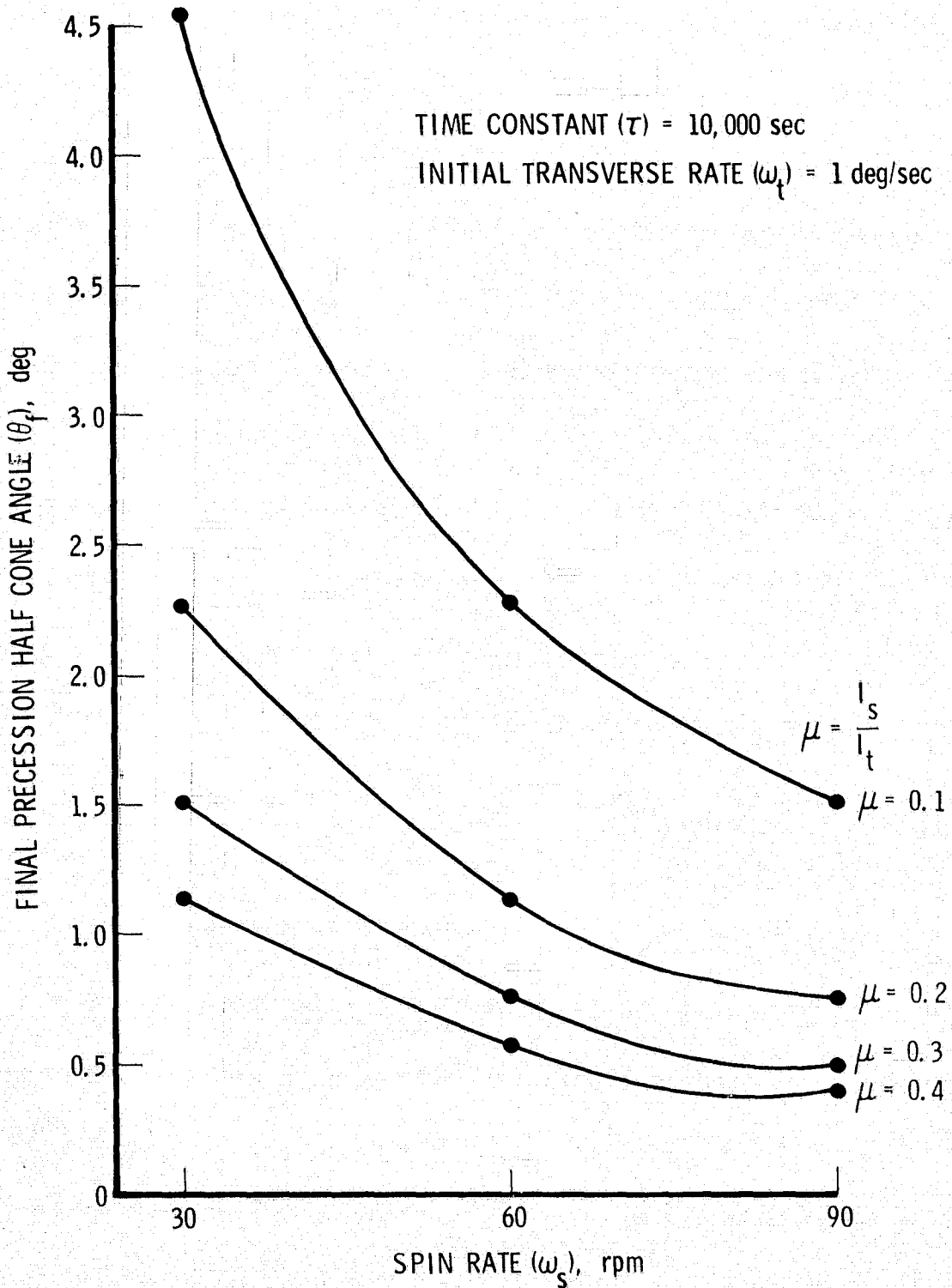

Figure 3-16. Final Precession Half Cone Angle for One-Hr Coast

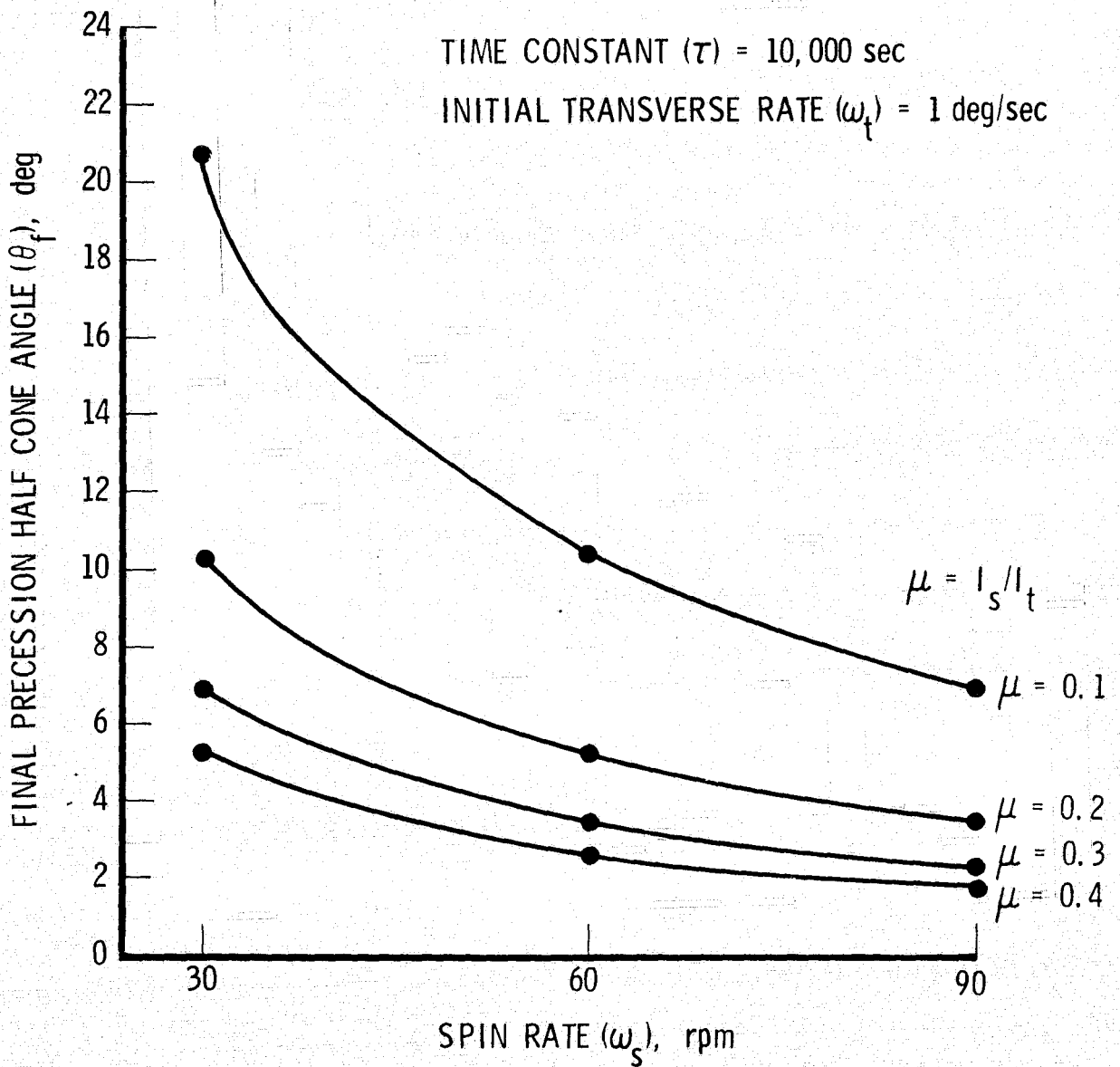

Figure 3-17. Final Precession Half Cone Angle for 5.25-Hr Coast

The terms inside the brackets were RSS'd for this analysis which will provide essentially a worst case estimate of the resulting attitude error due to the rocket burn. In addition, the spinning body will experience a wobble angle due to transverse rates that are introduced in the spinning body by the rocket burn. The half cone wobble angle can be determined by the following:

$$\theta_{\omega_B} = \frac{T\epsilon}{I_s \omega_s^2} \left[\frac{1}{(\mu - 1)} \right]$$

Presented in Figures 3-18 through 3-21 are the total attitude errors at SRM burnout and the resulting wobble half angles as a function of spin rate and inertia ratios. In addition, it should be noted that the analysis was based on a total thrust vector offset of one in. For a specific configuration, the offset must be determined and then the ratio of the actual offset to the one used in the analysis could be applied to the total attitude and wobble angles plotted in the attached figures (i.e., if the actual offset is only 1/2 in., the total attitude errors and wobble angles from Figures 3-18 through 3-21 would be multiplied by 0.5 or the errors would only be 1/2 the plotted values).

3.5.3.4 Attitude Errors Introduced in a Spinning Configuration Due to Separation of Spinning Bodies

For a spinning configuration which is experiencing precession caused by transverse angular rates, an attitude error will be experienced in the bodies when a separation event occurs. The resulting attitude deviation can be defined by the following equation:

$$\alpha_{sep_2} = \tan^{-1} \left[\frac{\omega_t}{\omega_s} \frac{1}{\mu_1} - \frac{1}{\mu_2} \right]$$

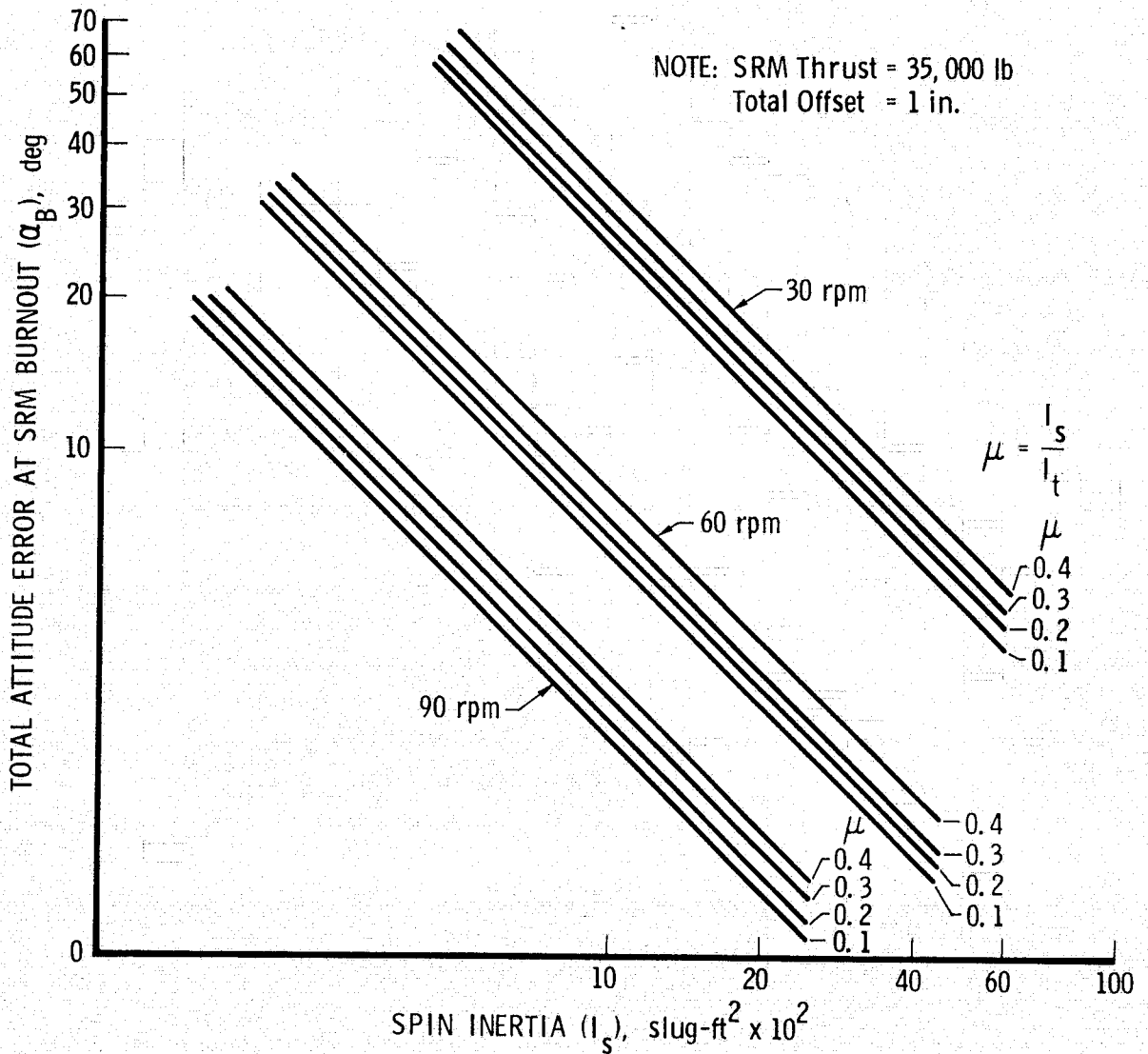

Figure 3-18. Predicted Total Attitude Error at SRM Burnout, Perigee Motor Injection

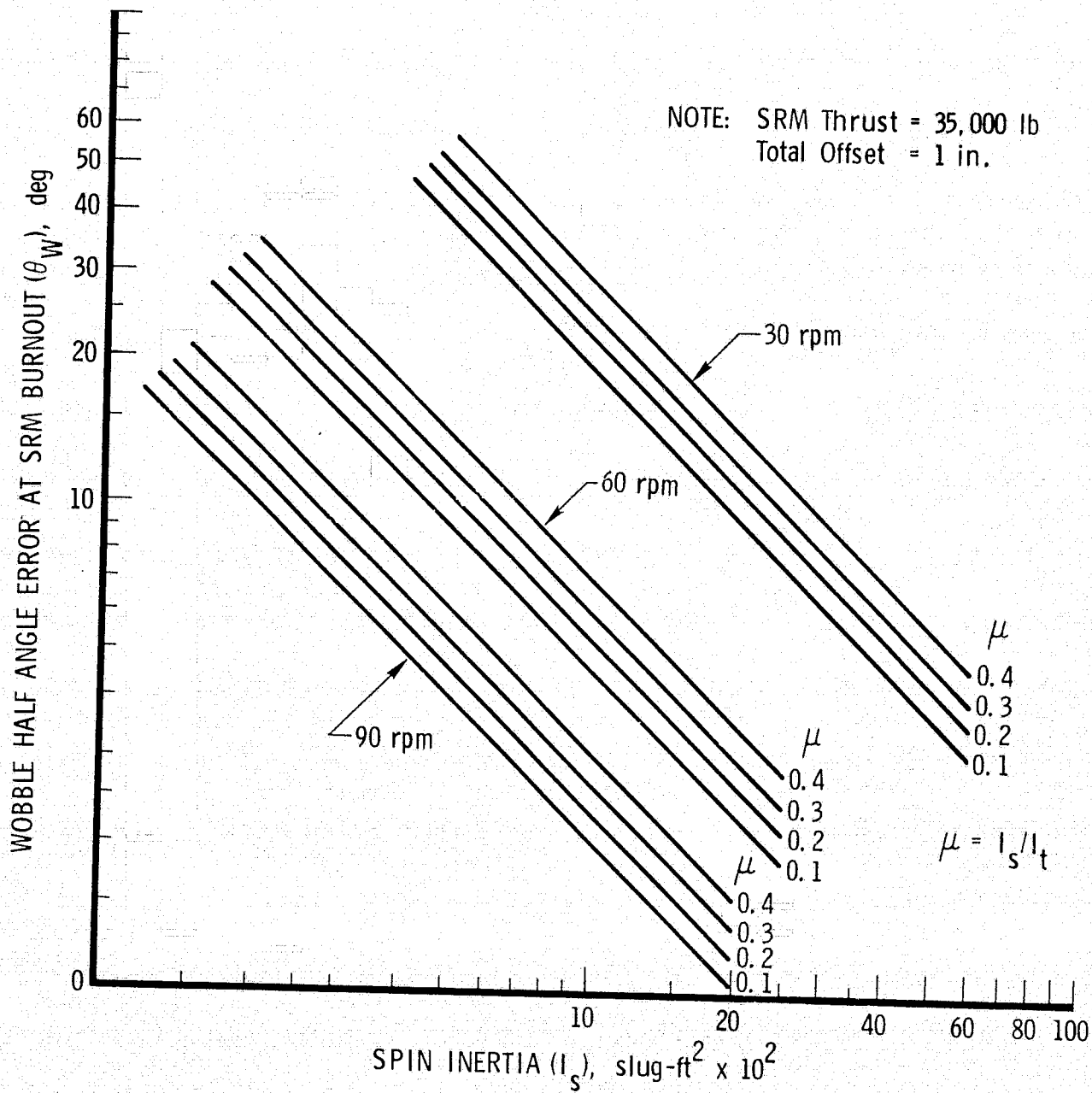

Figure 3-19. Predicted Wobble Angle at SRM Burnout, Perigee Motor Injection

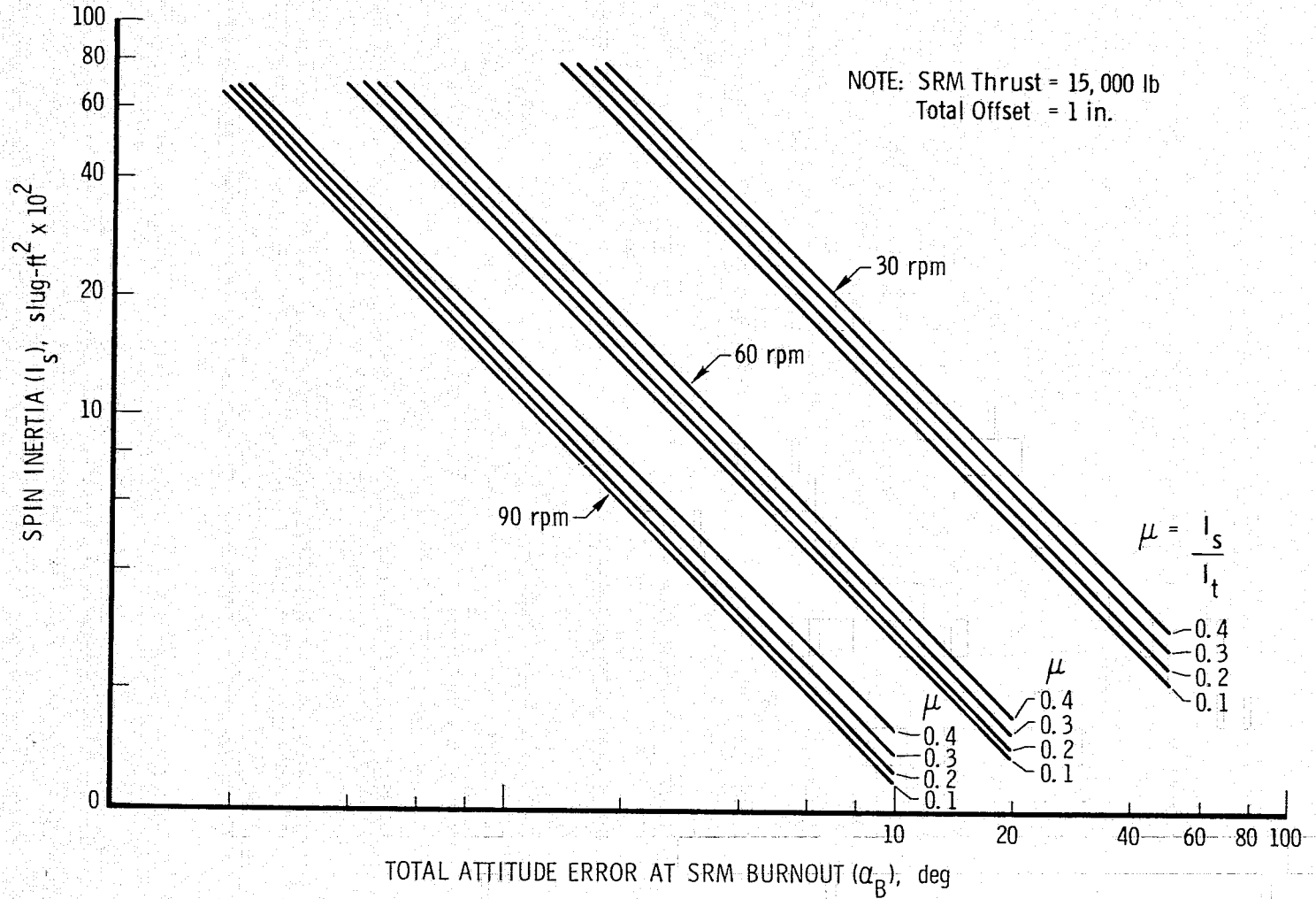

Figure 3-20. Predicted Total Attitude Error at SRM Burnout, Apogee Motor Injection

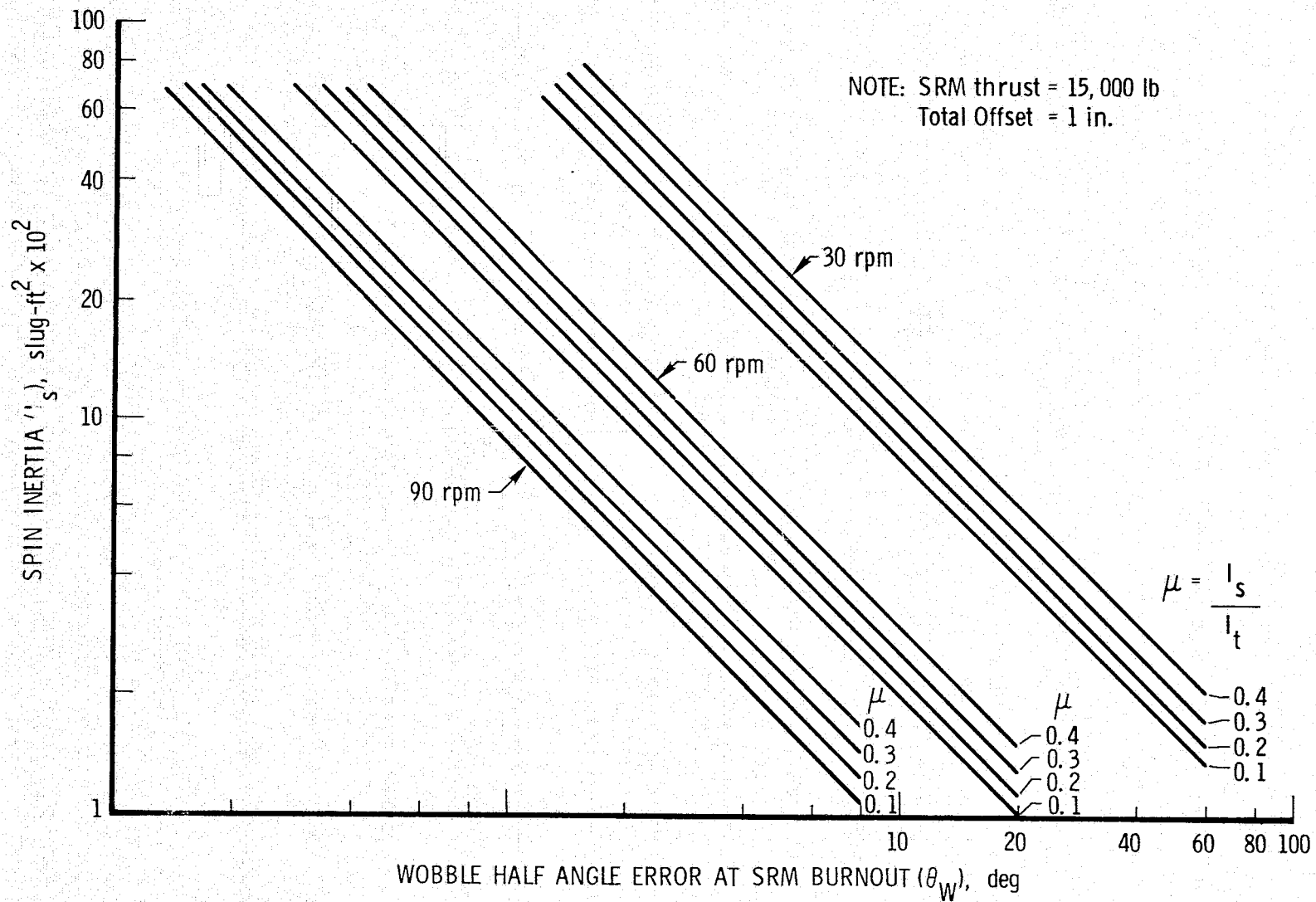

Figure 3-21. Predicted Wobble Angle at SRM Burnout, Apogee Motor Injection

where:

α_{sep_2} = Resulting attitude error in second body, deg

ω_t = Transverse angular rate prior to separation, rad/sec

ω_s = Spin rate, rad/sec

μ_1 = Inertia ratio of configuration prior to separation

μ_2 = Inertia ratio of second body after separation (assume $\mu_2 = 2\mu_1$)

The wobble half angle of the second body after separation is determined by:

$$\theta_{\omega_{sep_2}} = \tan^{-1} \left[\frac{\omega_t}{\omega_s} \frac{1}{\mu_2} \right]$$

A parametric analysis was conducted to determine the body attitude error after separation as a function of inertia ratios of the total configuration before separation and as a function of spin rate. It was assumed for this analysis that the inertia ratio of the configuration after separation was twice the initial inertia ratio.

Presented in Figure 3-22 is the attitude error of the remaining spinning body and resulting wobble half angle due to the separation event. This analysis assumed an initial transverse rate of one deg/sec for the combined configuration before separation. Additionally, the second body was assumed to have an inertia ratio that was twice the inertia ratio of the combined configuration.

3.5.3.5 Utilization of the Attitude Errors for Determination of Injection Errors

The previously discussed attitude errors of the spinning bodies were treated parametrically for each flight sequence which caused a perturbation in body attitude. In conducting a mission error analysis, the attitude errors due to the various events must be combined in a proper statistical

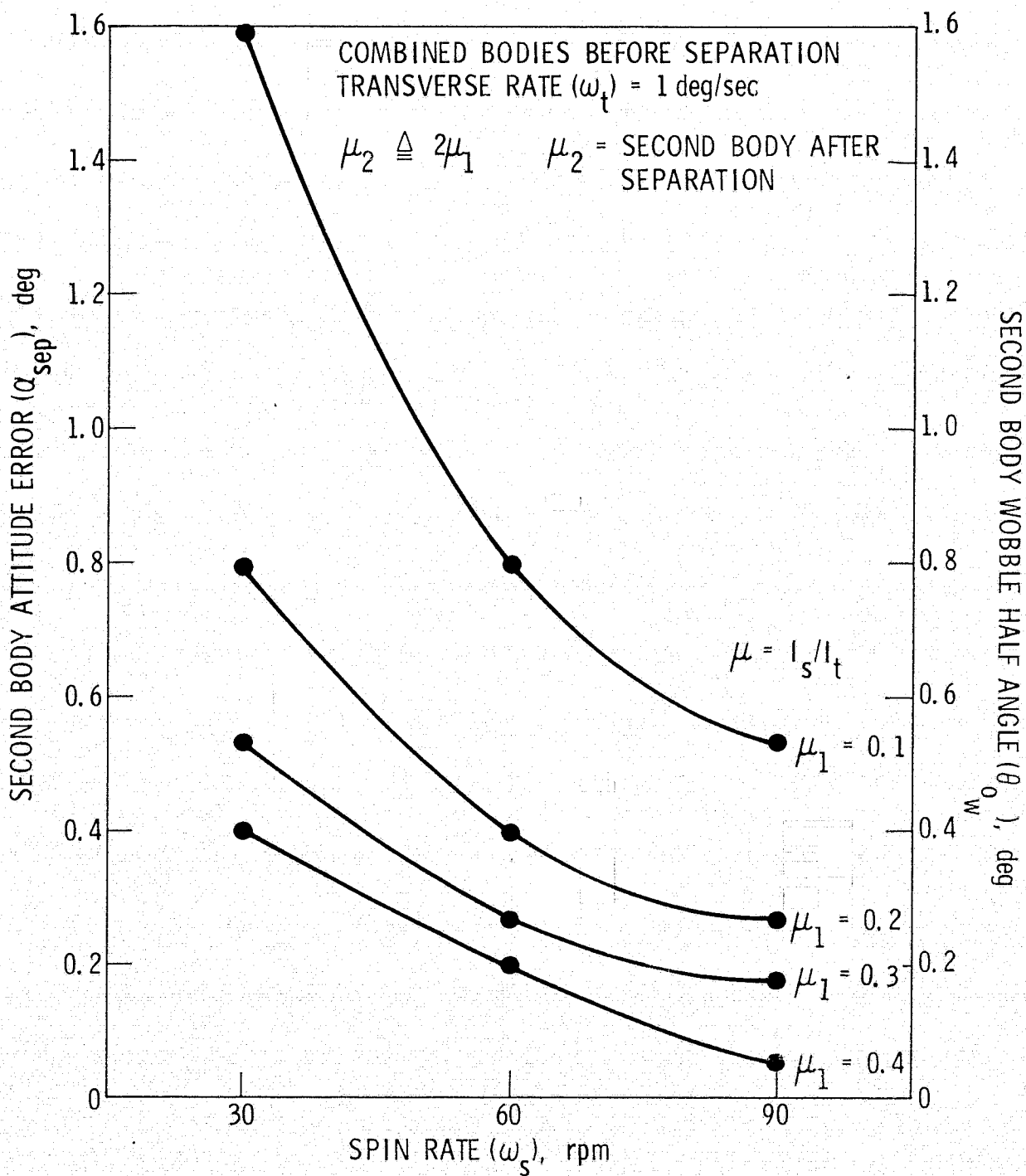

Figure 3-22. Attitude Error Due to Separation of Two Spinning Bodies

manner to obtain the proper attitude error at such time as a rocket burn would be accomplished. The total derived attitude error during the burn will contribute to flight path angle errors and velocity magnitude errors for the vehicle. To obtain these effects, a proper trajectory simulation must be utilized. The intent of this analysis was not to accomplish an orbital injection error analysis but only to investigate the attitude errors that could be experienced for a spinning body due to significant error sources.

SSUS MISSION ACCURACY DISCUSSION

As discussed in the preceding paragraphs, the SSUS orbital accuracy is a function of the characteristics of each satellite and the SSUS solid rocket motor system sized to inject the satellite. Other estimated error sources such as deployment from the Orbiter are system errors and do not change with the satellites.

Table 3-24 indicates how the geosynchronous transfer orbit errors differ between the four satellite designs analyzed. Table 3-25 shows how the heading error sources differ for these four satellites. These errors are of similar magnitude, but it should be noted that the important inclination error for AS-05A is twice that of the EO-57A satellite. However, in the subsequent AKM injection burn, much of these transfer orbit errors are biased out and the remaining errors corrected by the satellite ACS Δ velocity system.

Table 3-26 compares the final geosynchronous orbit injection accuracies of the SSUS with those of the Titan IIIC, generic IUS, and the SSPDA satellite injection requirement data. Note that the two columns of SSUS data provide a measure of the ability to reduce error by ground-commanded biasing of the AKM velocity vector to reduce final errors. The resultant RSS velocity error is approximately one half of the "unguided" nominal AKM burn data.

Tables 3-27 and 3-28 compare the typical accuracy data for the EO-57A/SSUS with the Delta 2914 and Atlas Centaur ELVs commonly used with spin-stabilized satellites having AKMs. These data are for the geosynchronous transfer orbit. These data show that the present understanding of SSUS error sources and their evaluation provide a 3σ accuracy essentially equal to the Delta 2914 data. Atlas Centaur accuracy is considerably better than either the SSUS or Delta, due to the perigee burn transfer injection being done by the second burn of the Centaur inertially guided liquid rocket stage. Table 3-28 shows data from seven Delta 2914 flights indicating considerably better actual performance than the 3σ predictions. It is possible that the predicted errors are based on overly conservative assumptions.

Table 3-24. SSUS Geosynchronous Transfer Orbit Accuracy (3σ)
 $296.23 \times 35,786$ km ($160 \times 19,323$ nmi)
 Inclination 26.15 deg

<u>Transfer Orbit Deviation</u>	<u>EO-57A EO-58A</u>	<u>AS-05A</u>	<u>EO-07A</u>	<u>EO-09A EO-59A EO-62A</u>
ΔH_A km (nmi)	1105.8 (597.1)	1106.0 (597.2)	1105.8 (597.1)	1105.8 (597.1)
ΔH_p km (nmi)	4.84 (2.61)	8.20 (4.43)	6.28 (3.39)	5.43 (2.93)
Δ Period, min	21.72	21.73	21.72	21.72
Δ Eccentricity	0.00642	0.00643	0.00642	0.00642
Δ Inclination, deg	0.107	0.211	0.153	0.127

Table 3-25. SSUS Injection Error Analysis

DYNAMIC STABILITY STUDIES

<u>SATELLITE</u>	<u>SPIN RATE</u> rpm	<u>HEADING ERRORS (DEGREE)</u> <u>END OF BURN</u>	
		PKM	AKM
EO-09A	45	0.337	0.230
EO-57A	100	0.450	0.393
AS-05A	45	0.742	1.322
EO-07A	45	0.602	0.48

Thrust Vector Misalignment = 0.002 Radians

Table 3-26. Geosynchronous Injection Accuracies

	Typical Satellite Requirement ¹	IUS ²	THIC	EO-57A/SSUS	
				<u>3</u>	<u>4</u>
ΔV_T m/sec (ft/sec)	12.89 (42.3)	4.88 (16)	9.14 (30.0)	35.96 (118)	42.55 (139.6)
ΔV_R m/sec (ft/sec)	12.89 (42.3)	22.86 (75)	30.48 (100.0)	104.24 (342)	30.48 (100.0)
ΔV_N m/sec (ft/sec)	17.19 (56.4)	3.66 (12)	24.38 (80.0)	42.67 (140)	28.41 (93.4)
ΔP_T km (nmi)	46.3 (25)	122.2 (66)	148.2 (80.0)	135.2 (730)	N. A. ⁵
ΔP_R km (nmi)	46.3 (25)	92.6 (50)	129.6 (70.0)	110.2 (595)	10.78 (582.2)
ΔP_N km (nmi)	62.0 (33.5)	74.1 (40)	83.3 (45.0)	759.3 (410)	9.26 (5.0)
ΔV (RSS) m/sec (ft/sec)	25.05 (82.2)	23.65 (77.6)	40.08 (131.5)	118.26 (388)	59.59 (195.5)
ΔV Relative to Satellite Requirement	0	(-1.40) (-4.6)	+14.93 (+49.0)	+93.26 (+306)	+34.44 (+113.0)

¹SSPDA Data for EO-09A, EO-57A, and EO-07A

²SR-IUS-100

³Preliminary Data, February 1975, Start Task I w/o AKM Bias Correction

⁴Data, June 1975, with AKM Bias Correction

⁵Not applicable - Payload in 5.5 deg/day drift orbit 15.24 m/sec 50 ft/sec ΔV

Table 3-27. EO-57A/SSUS, Delta 2914, and Atlas Centaur Geosynchronous Transfer Orbit Accuracy Comparison (3σ)

Transfer Orbit Deviation	EO-57A/SSUS 296 x 35,786 Km (160 x 19,323 nm)	Delta 2914 185 x 35,786 Km (100 x 19,323 nm)	Atlas Centaur 185 x 35,786 Km (100 x 19,323 nm)
ΔH_A Km (nm)	1105.6 (597)	1018.6 (550)	250 (135)
ΔH_p Km (nm)	5.43 (2.93)	7.96 (4.3)	4.63 (2.5)
Δi degree	0.107	0.33	0.038

NOTE:

Inclination 26.15°

Atlas/Centaur does not use SRM for Perigee Injection.

Table 3-28. EO-57A/SSUS and Delta 2914 Accuracy Comparison

<u>Transfer Orbit Deviation</u>	<u>Delta 2914</u> <u>100 x 19,330 nmi 26 deg Inclined</u>		<u>EO-57A/SSUS</u> <u>160 x 19,330 nmi 26 deg Inclined</u>
	3σ Spec	7 Flights mean (spread)	3σ Prediction
ΔH_A km (nmi)	1018.6 (550)	+80.6 (-40.7 to 322) +43.5 (-22 to +174)	110.6 (597)
ΔH_P km (nmi)	7.96 (4.3)	+0.41 (-1.50 to 1.85) +0.22 (-0.81 to +1.0)	4.84 (2.61)
Δi deg	0.33	-0.02 (-0.07 to +0.027)	0.107

Final Orbit Comparison Spacecraft Error Correction Requirement after AKM Burn

	<u>NATO III 364-kg (803-lb) Spacecraft</u> <u>Delta 2914 Planned Flight Feb. 76</u>	<u>EO-57A 341-kg (752-lb)</u> <u>Spacecraft SSUS Study</u>
ΔV m/sec (ft/sec)	43 (141)	46 (150)
Hydrazine Equivalent, kg (lb)	7.6 (16.8)	7.6 (16.7)

Table 3-28 also shows the ΔV spacecraft orbit correction requirements for the Delta 2914-launched NATO III Spacecraft and the equivalent SSUS-launched EO-57A. Nearly equal ΔV and correction propellant requirements are predicted. Tables 3-29 and 3-30 show the satellite N_2H_4 fuel budget for the NATO III satellite and the Atlas/Centaur-launched Fleet-satcom payload.

Figure 3-23 shows the approximate relationship of hydrazine correction propellant to correction velocity requirement. In general, relatively large errors can be corrected with modest percentage increase in satellite weight through addition of correction propellant.

Present evaluations and understanding of the SSUS system indicate it can provide useful orbital accuracy similar to the present Delta 2914 but inferior to inertially guided, three-axis upper stage ELVs, IUSs, or Tugs.

Table 3-29. NATO III Fuel Budget

Maneuver	$\Delta\theta$ (Deg)	ΔVel (f/s)	Total Impulse (Lbf-Sec)	Rotational Efficiency (%)	Avg. Press. lb_f/in^2	No. Axial Pulses	No. Radial Pulses	Weight Propellant (Lb)
AKM ATTITUDE	139		1,340	0.95	280	2,770		6.4
SPIN AXIS ERECTION	118		1,030	0.948	254	2,300		5.0
STATION ACQUISITION		100	2,460	0.945	224		6,000	12.0
ERROR ALLOWANCE		141	3,400	0.940	182		9,780	16.8
STATION KEEPING		12	280	0.93	152		1,465	2.2
STATION CHANGE		100	2,200	0.935	152		7,400	11.1
ATTITUDE CONTROL	38		260	0.93	152	1,400		2.1
TOTAL		353	10,970			6,470	24,645	55.6
WEIGHT OF PRESSURANT								1.3

NOTES:

Weight at Liftoff 1542 lb (including AKM)

Weight on Orbit 803 lb

Average Isp 197.3 Sec. (Blowdown System)

Table 3-30. ACS Propellant Budget

<u>Spacecraft Weight</u>	<u>Fleetsatcom Atlas/Centaur Launched 907 kg (2000 lb)</u>		I_{sp} varies between 180 and 200 sec
	kg	(lb)	
N_2H_4 lb			
Spinup	2.72	(6)	
Precession Maneuvers during Transfer Orbit and Subsequent to AKM Burnout	2.72	(6)	
Despin	2.72	(6)	
Initial Acquisition, ΔV Correction, and Control	12.25	(27)	
15 deg/day (ΔV)	38.56	(85)	
3 deg/day (ΔV)	9.07	(20)	
East/West Station Keeping	4.54	(10)	
	<u>75.58</u>	<u>(160)</u>	
Contingency and On-Orbit Attitude Control	9.07	(20)	
	<u>81.65</u>	<u>(180)</u>	

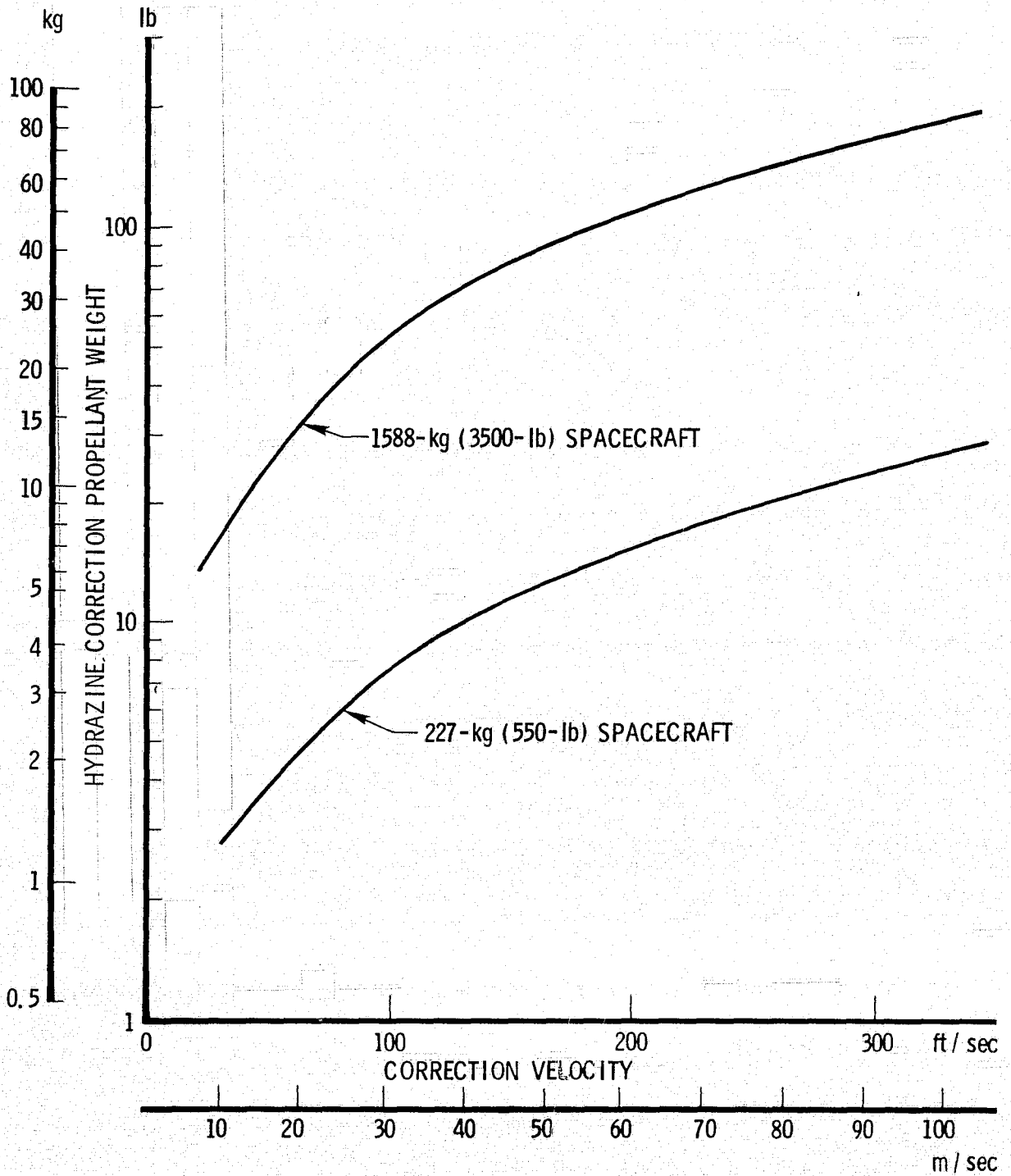

Figure 3-23. Spacecraft Correction Propellant Requirement, Geosynchronous Mission

3.7

SSUS STAGE DESIGN AND DEPLOYMENT CONFIGURATION

3.7.1

Approach

The objective of this study was to define and size the SSUS stage design, define a feasible spinup and deployment scheme for separating the payload from the Orbiter bay, and identify the problem areas. Because the number of potential satellites were of various sizes and shapes, it was necessary to first narrow the choice to two representative vehicles. For the small satellite, the EO-57A satellite is used as representative. This is a 75-in. diameter \times 122 in., 648-lb, spin-stabilized satellite. For the large satellite, the EO-09A satellite was used as representative. This is a 177-in. diameter \times 260-in., 3743-lb, three-axis controlled satellite.

There are two basic payload deployment options:

- a. Spin table option - satellite/SSUS spin up partially or fully on Orbiter attached spin table prior to injection.
- b. External spin option - satellite/SSUS completely removed from Orbiter bay by automatic ejection system or use of Orbiter mechanical manipulator arm (Figure 3-24). Satellite may be deployed either in a controlled or in an unstabilized condition.
 1. Three-axis satellite (EO-09A)/SSUS deployed in the three-axis mode of control with RF command spinup and three-axis mode of control off
 2. Spin-stabilized satellite (EO-57A)/SSUS deployed unstabilized, spinup commanded, satellite sensors to determine attitude, Orbiter commands satellite precession jet firing to correct attitude pointing verified by sensors (position determined by original Orbiter deployment)

Design wise, the deployment option that has the greatest impact on the payload/Orbiter interface area is the spin-table option. As such, the primary design effort was directed toward this option and the problems associated with it.

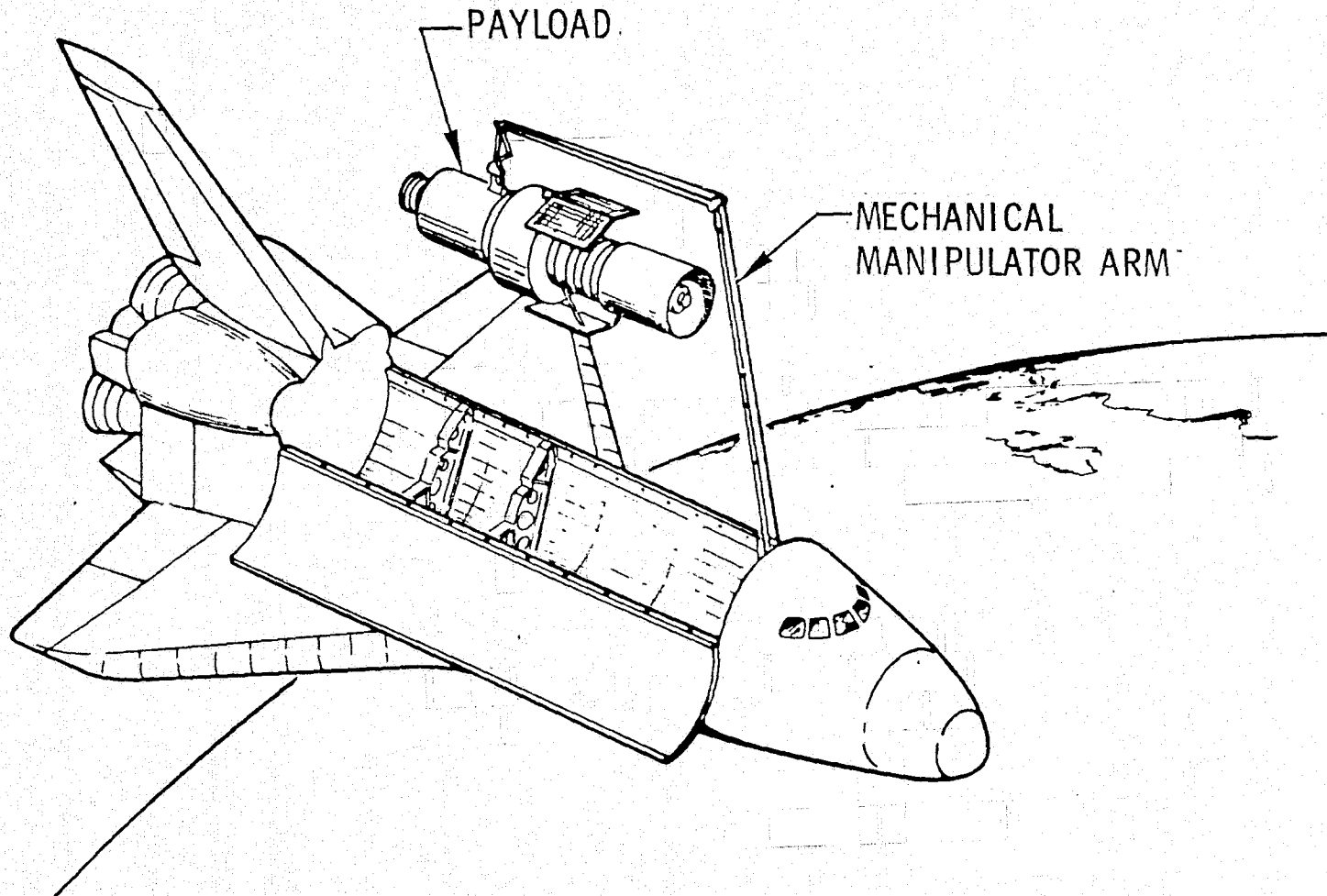

Figure 3-24. External Spin Option

The ground rules established and the assumptions used in this study include:

- a. Large SSUS Stage
 1. Modified AKM SRM Model 033 (UTC) (New Motor No. 2)
 2. Modified PKM SRM Model 014 (UTC) (New Motor No. 1)
 3. Spin Rate: Up to 45 rpm
- b. Small SSUS Stage
 1. AKM SRM TE-M-616 (Thiokol)
 2. Modified PKM SRM Model 033 (UTC) (New Motor No. 2)
 3. Spin rate: Up to 100 rpm
- c. TT&C: Pair of deployable bi-cone omni antennas
- d. TT&C Electronic Equipment: Similar to Intelsat III equipment
- e. Use of Orbiter ACS to offset all spin table torques and deployment reactions.

The areas discussed will include the following: SSUS design, spinup approach, deployment, spinup methods, separation system selection, cradle support, and the Orbiter bay arrangement.

3.7.2 Discussion

3.7.2.1 SSUS Design

The small and large SSUS stage configurations are shown in Figures 3-25 and 3-26, respectively, along with the spin table. The SSUS is a two-stage vehicle whose size is dictated primarily by the size of the apogee and perigee kick motors. The structure is skin-and-stringer construction with internal spaced ring frames and external hat sections with local beefed-up sections around the trunnion points that attach to the support cradle.

An avionics bay is located in the forward adapter section of the second stage. This houses the SSUS electronic support equipment. A pair of deployable omni bi-cone antennas are also mounted from this end

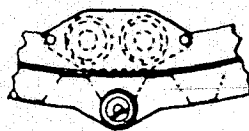
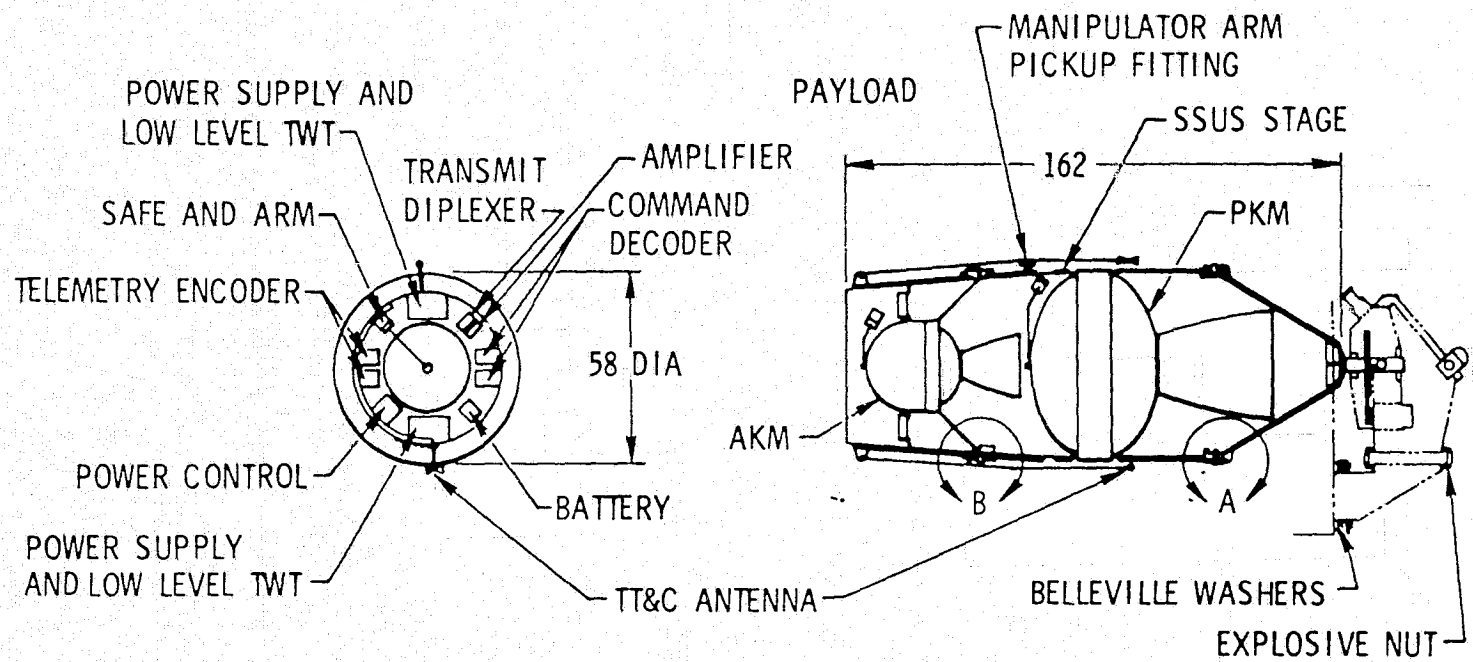

SEC-AA

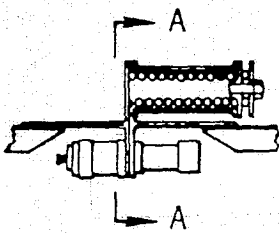

EXPLOSIVE NUT BOLT CATCHER

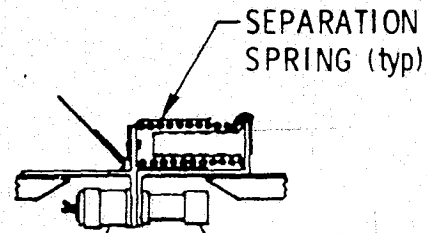

VIEW-B (enlarged)

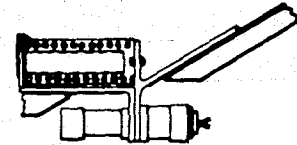

VIEW-A (enlarged)

Figure 3-25. Small SSUS Configuration

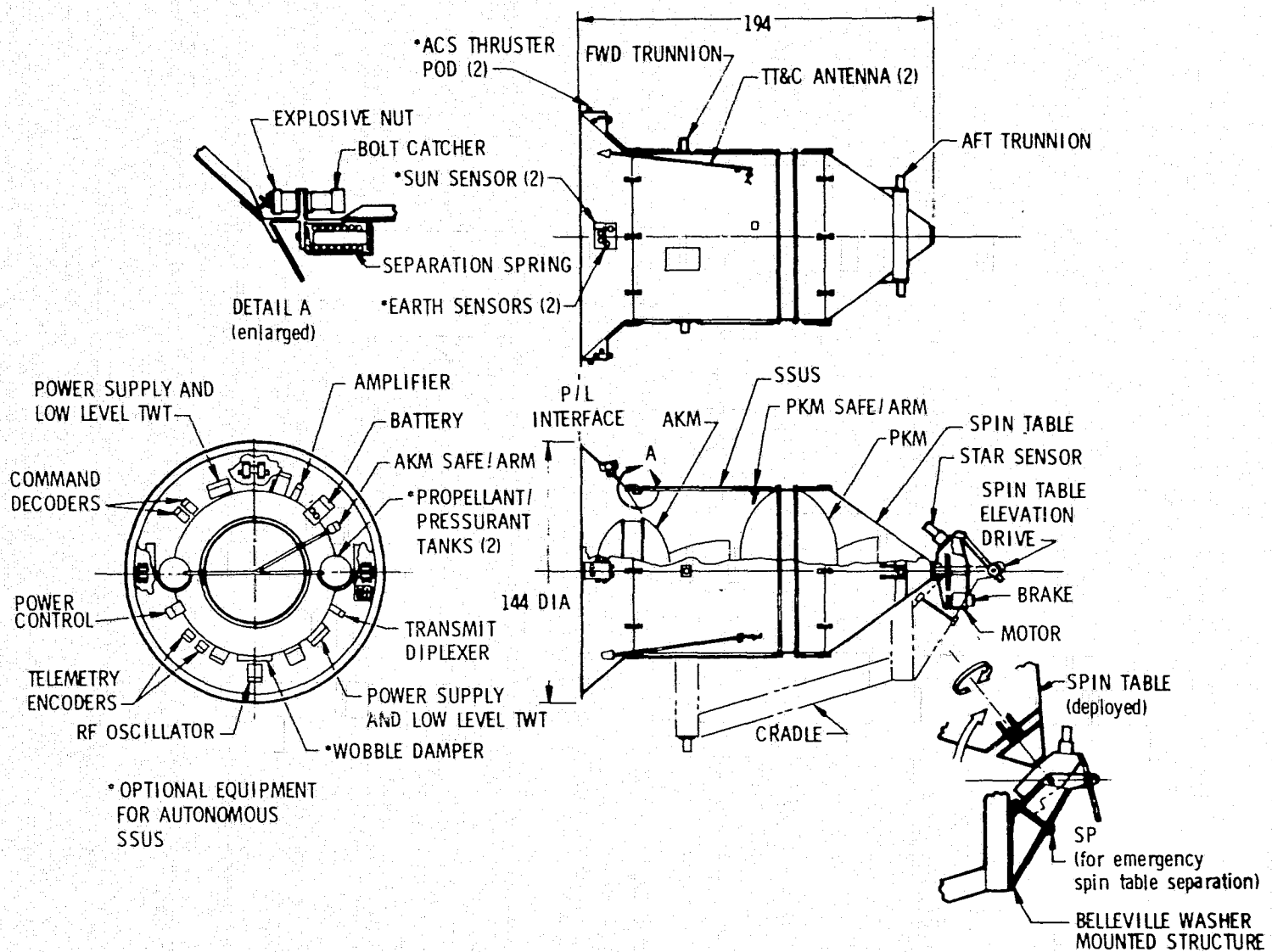

Figure 3-26. Large SSUS Configuration

for TT&C operations. The SSUS stage will depend upon the satellite interface for all its command and control requirements.

For an autonomous SSUS option, one which would be capable of functioning without satellite service of any kind, an entire stage attitude control and orientation subsystem would have to be added. This system would include sun sensors, earth sensors, wobble damper control, and a complete ACS system added to the SSUS as noted in Figure 3-26.

3.7.2.2 Spinup Approach

The options are to spin up the payload prior to or after elevation to the deployment position. Little advantage is seen in the prior in-bay spinup option, other than to check out the spin-table mechanism. The disadvantages of this option are several:

- a. Complex payload/cradle support interface area
- b. Heavier spin-table support required because of gyroscopic torque effects
- c. Tight payload/Orbiter bay envelope fit (EO-09A)

In view of this, the spinup after elevation deployment approach is selected.

3.7.2.3 Elevation Deployment

To deploy the payload, the cradle launch locks holding the SSUS trunnion points are unlatched. A jackscrew arrangement connecting one end of the spin table to the aft end of the mounting bracket is activated which pivots the payload about a trunnion pivot fitting on the spin-table mechanism housing. A star sensor mounted on the non-spinning portion of the spin table is used to guide the deployment erection angle.

The payload is elevated above the Orbiter bay radiator hinge-line structure to maximize the clearance between the payload and any Orbiter structure. In case of a malfunction in the elevation mechanism and the payload cannot be reattached back in the support cradle, the payload may be ejected if sufficiently elevated. Calculations show that 17 or 18 deg minimum elevation angle is needed for the payload to clear the aft portion of the Orbiter crew

cab structure. If the same elevation malfunctions occurs below this angle, the Orbiter mechanical manipulator arm will have to be used to lift the satellite/SSUS/spin table out of the cradle for abort. An explosive nut separation system is provided in the spin table support from the cradle for this purpose.

3.7.2.4 Spinup Methods

In the ground rules, spin speeds up to 45 rpm are indicated for the large payload and up to 100 rpm for the smaller payload. A dynamic analysis will have to be conducted in this area to help ascertain what spin speed is feasible. There has to be a correlation between the spin speed and the spin table structure stiffness to insure that the two are sufficiently compatible to preclude the possibility of the spin frequency coupling with the natural bending frequencies of the satellite/SSUS.

As a guide line, the first lateral mode frequency of the satellite/SSUS mounted on the spin table and its supporting structure should be at least twice the maximum spin frequency.

If in meeting this requirement, a heavy weight penalty is imposed and the spin table design is complicated, alternate spin schemes should be considered. This should include a partial spinup at low speed with the Orbiter attached to the spin table, followed by a complete spinup at the desired speed after separation using the thrusters on the payload or the SSUS.

There are many ways to spinup the spin table. The use of solid or hot gas thrusters, for spinup is ruled out because of possible payload bay contamination, and a cold gas system requires a large tankage system. For example, spinning up the large EO-07A/SSUS vehicle to 45 rpm requires two 20-in. diameter tanks of N_2 . Even with a cold gas system, if the nozzles are located near the bay, fine dust particles could be stirred up in the Orbiter bay that would be objectionable. A better scheme would be a mechanical drive system along the lines shown in Figures 3-25 and 3-26.

The spin table is belt driven and is controlled by a motor/brake system. A cone structure is used to tie the SSUS aft skirt to the spin mechanism to form the complete spin-table assembly. Launch loads are carried from the support cradle through a pair of forward trunnion points in the SSUS and an aft pair mounted on the spin-table cone structure section. No launch loads are carried through the spin bearings nor the spin-table drive mechanism because of the mounting arrangement between the cradle and the spin-table mechanism support that prevents the transmittal of launch loads. This mounting arrangement is provided by the deflection of Belleville washers at the support attach points. The bolt preloads the washers to established the stiffness of the table mechanism support. If a stiffer support structure is required following payload erection to meet the spin dynamics, a clamp can be provided to lock the mounting. After spinup, the payload is ready for separation.

3.7.2.5 Separation Systems

The separation system for separating the satellite/SSUS payload from the spin table and the SSUS second stage from the first stage consists of activating a number of captive explosive nuts in conjunction with bolt catchers around the periphery of the separation joint. A series of springs then pushes the severed sections apart. This type of separation system was selected for the following reasons:

- a. It is ideal for joining concentrated load points. The advanced configuration drawing of the EO-09A vehicle indicate hard-point attachments. Concentrated loads will be dumped into SSUS structure from the cradle attach trunnion points.
- b. Light weight
- c. Contamination free. This is important for the SSUS/spin-table separation joint since it is severed inside the Orbiter bay.

There are other separation joint concepts available. Many of them were reviewed as possible separation candidates. The key reasons some of them were rejected were as follows:

- a. Explosive bolt offered possible contamination
- b. V-Band requires a heavy vehicle ring frame at the joint, and a large-diameter size such as the EO-09A has never tried. It is not suitable for a concentrated loading mode.
- c. Explosive belly strip requires a heavy backup frame at the joint with possible shrapnel-type contamination.
- d. Latch requires a heavy and complex linkage design.

3.7.2.6 Cradle Support

The primary cradle attach point locations shown in Figures 3-27 and 3-28 are those documented in the "DoD Space Shuttle System Summary" report by SAMSO dated 1 August 1974. A four-point retention system is used on the support cradle to provide statically determinate loads. The forward cradle support uses a longeron location at a station to carry both longitudinal (X) and (Z) loads with a lower retention point for lateral (Y-axis) restraint. On the aft support, another station on the longeron provides the Z-axis restraint. This support arrangement will not permit loads to be induced into the payload/cradle structure by the Orbiter bay deflections. A greater in-depth investigation should be conducted into other structural support systems including statically indeterminant schemes. This investigation is needed to insure that minimization of the overall structured weight penalty is considered in designing the cradle to meet the spring stiffness requirement to properly support and deploy the payload.

3.7.2.7 Orbiter Bay Arrangement

The Orbiter payload bay is 15 ft in diameter x 60 ft long. It is sufficiently large to carry one EO-09A satellite/SSUS or four EO-57A satellite/SSUS configurations. For the EO-57A satellite configuration, a mounting arrangement with one satellite above the other in vertical pairs (one above the other in the Z plane) was considered, but it was dropped due to the deployment complexity and heavy cradle structure required to support the payload. A side-by-side tandem pair arrangement as shown in Figure 3-27 was selected. This arrangement allows each satellite to be launched

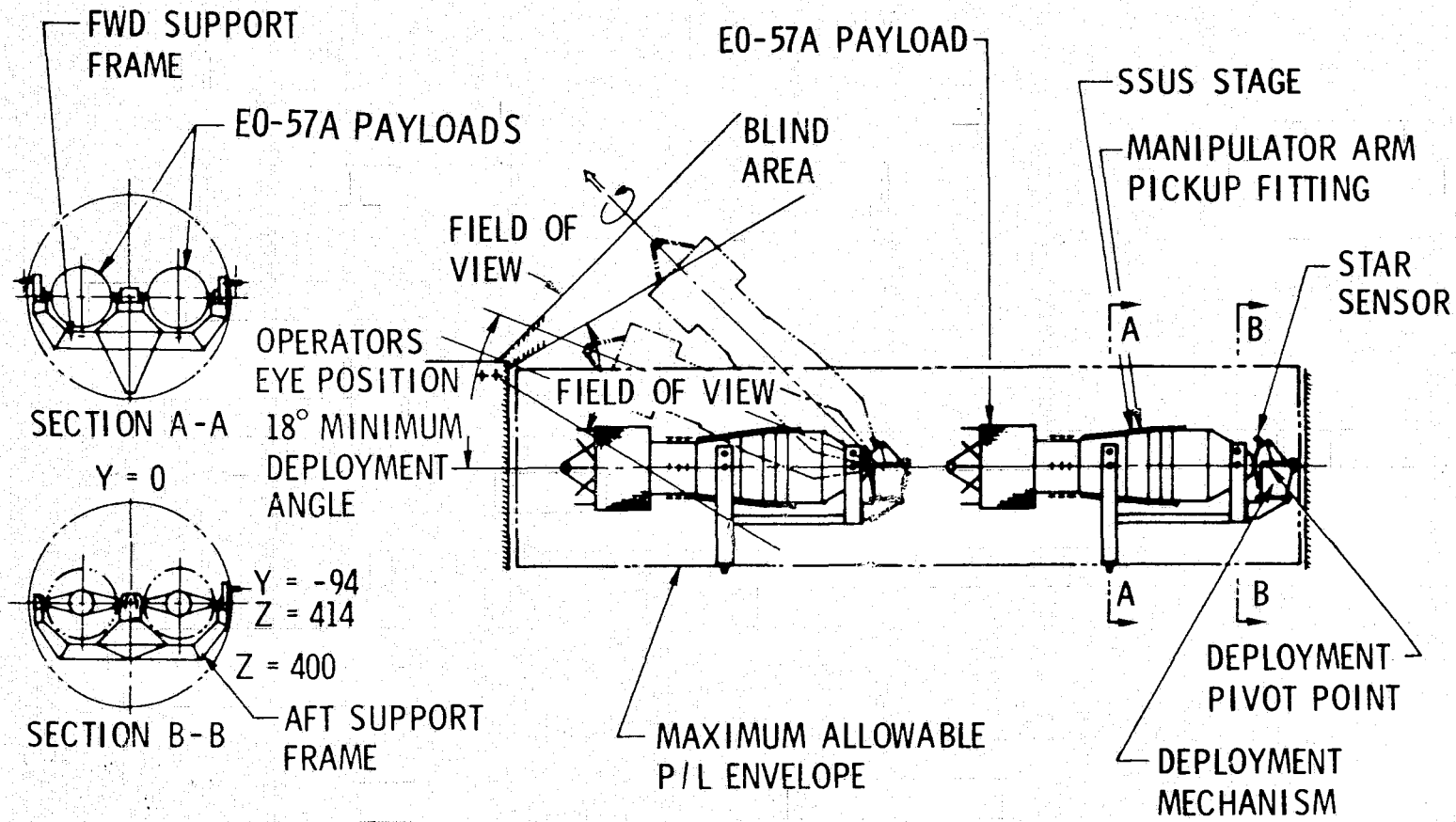

Figure 3-27. EO-57A/SSUS Bay Arrangement

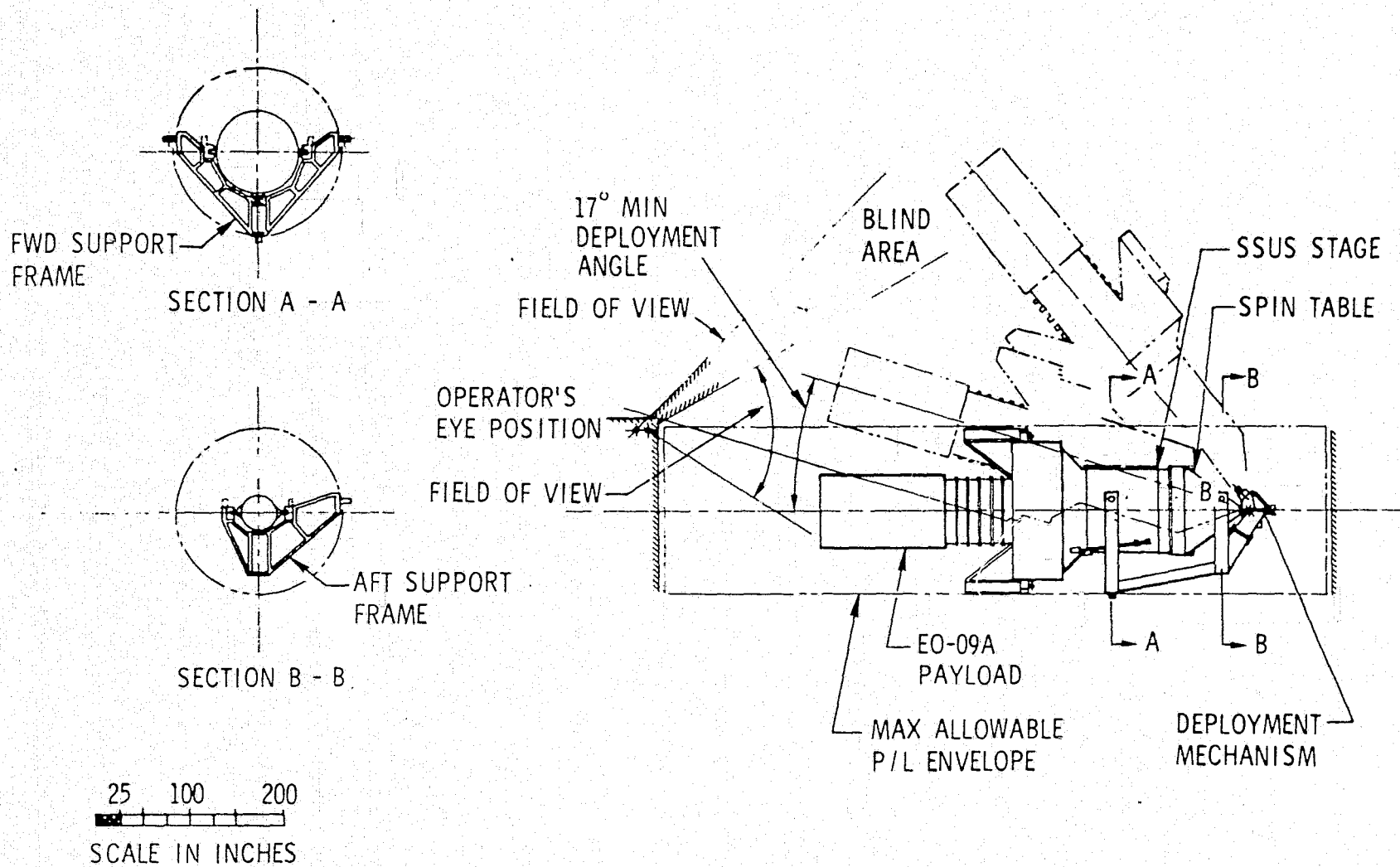

Figure 3-28. EO-09A/SSUS Bay Arrangement

individually without disturbing the others. The allowable Orbiter bay c.g. loading boundary is shown in Figures 3-29 and 3-30. It can be seen that in case of abort, the lateral c.g. shift along the Y-axis is critical. A deployment of a satellite from one side of the Orbiter must be counter balanced with a deployment from the opposite side. Any attempt to abort with an odd number of EO-57A satellites is beyond the design capability of the Orbiter unless a shifting counterweight system is incorporated into the Orbiter bay to compensate for the off loading.

3.7.3 Conclusions

This study has shown that a system for spinning up and deploying a satellite/SSUS vehicle from the Orbiter bay appears feasible. Some of the results derived from this study included:

- a. Spinup of the payload after deployment erection is more desirable than in an in-bay spinup scheme.
- b. No difficulty will be encountered in erecting the payload above the Orbiter radiator hinge-line structure area.
- c. A contamination-free separation system can be provided with the explosive nut/ejection spring system.
- d. One EO-09A/SSUS vehicle or up to four EO-57A/SSUS vehicles can be launched per flight from the Orbiter.
- e. In an abort, an Orbiter with odd numbers of EO-57A/SSUS remaining in the bay will exceed Orbiter c.g. limit restrictions.

It is recommended that if this study is to be further pursued, an analysis be conducted on the compatibility of the spin-table support structure and the spin rate. This is to insure that the possibility of coupling with the natural bending frequencies of the payload does not occur.

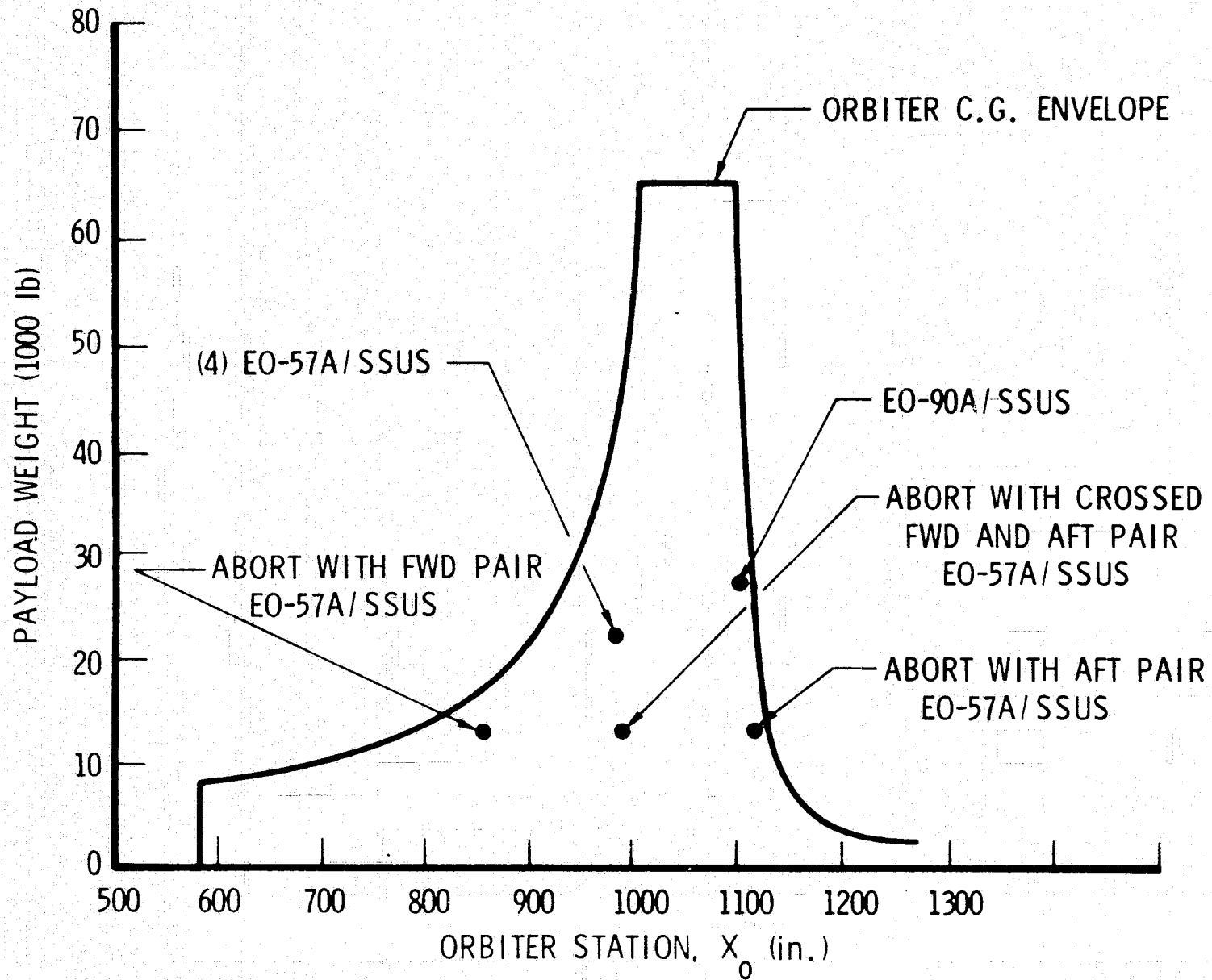

Figure 3-29. C. G. Location Summary

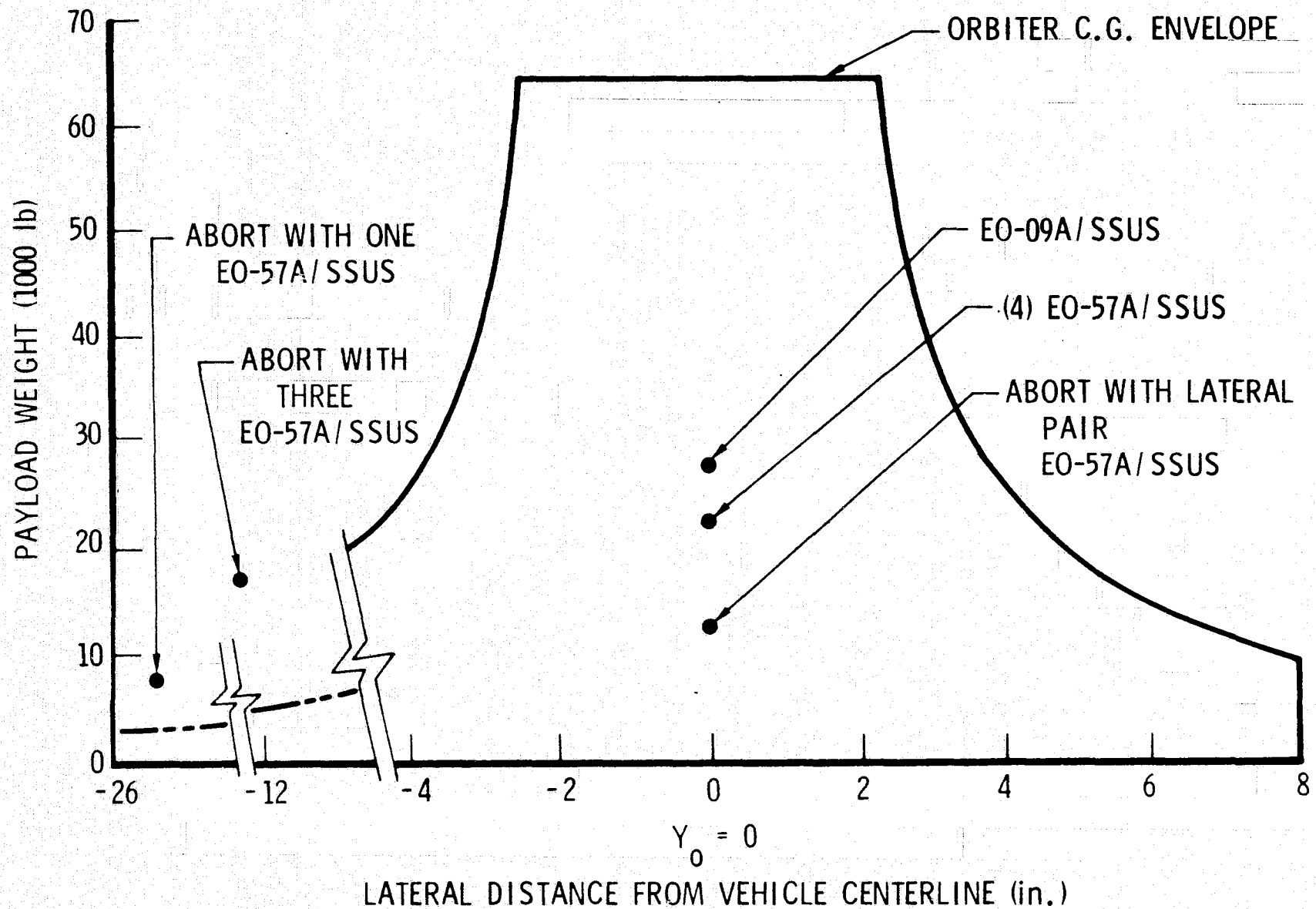

Figure 3-30. Cargo C.G. Limits (Along Y-Axis)

ALTERNATE CONCEPTS CONSIDERED

The Task 2.6 SSUS design activities and analyses primarily addressed the Orbiter spin-table deployment concept for two-stage geosynchronous missions. This concept was the direct system approach, and in that sense, constituted a baseline design. The spin-table design was the most straightforward of the initial and subsequently suggested concepts and permitted stability analyses, accuracy analyses, and concept design layouts to proceed concurrently. This fitted the time and manpower constraints of the study effort.

Other deployment concepts and system design options were suggested but were not pursued for the foregoing reasons. Some of these concepts deserve a further examination in competition to the spin-table concept, particularly in view of the spin-table cradle development costs estimates which were made last in the Task 2.6 study. Studies suggest less orbital accuracy for external spinup concepts, but the loss of accuracy may not be prohibitive when compared to possible cost reductions through avoidance of spin-table development and qualification.

These alternate concepts would utilize the remote manipulator system (RMS) to deploy the SSUS from an IUS-style cradle in the Orbiter (Figure 3-31) and require a completely external spinup and pointing alignment. The Orbiter would still provide position navigation. Concepts considered include three-axis satellite control of the SSUS until spinup (Figure 3-32), added SSUS short-life systems, laser corner-reflector alignment by the Orbiter (Figure 3-33), and even a retrievable spin table (Figure 3-34). (However, this last is probably more costly than the Orbiter bay spin table.) Likewise, no effort was made to achieve a realistic layout of a three- or four-stage planetary SSUS (Figure 3-35), since the planetary mission design/accuracy analyses were not available.

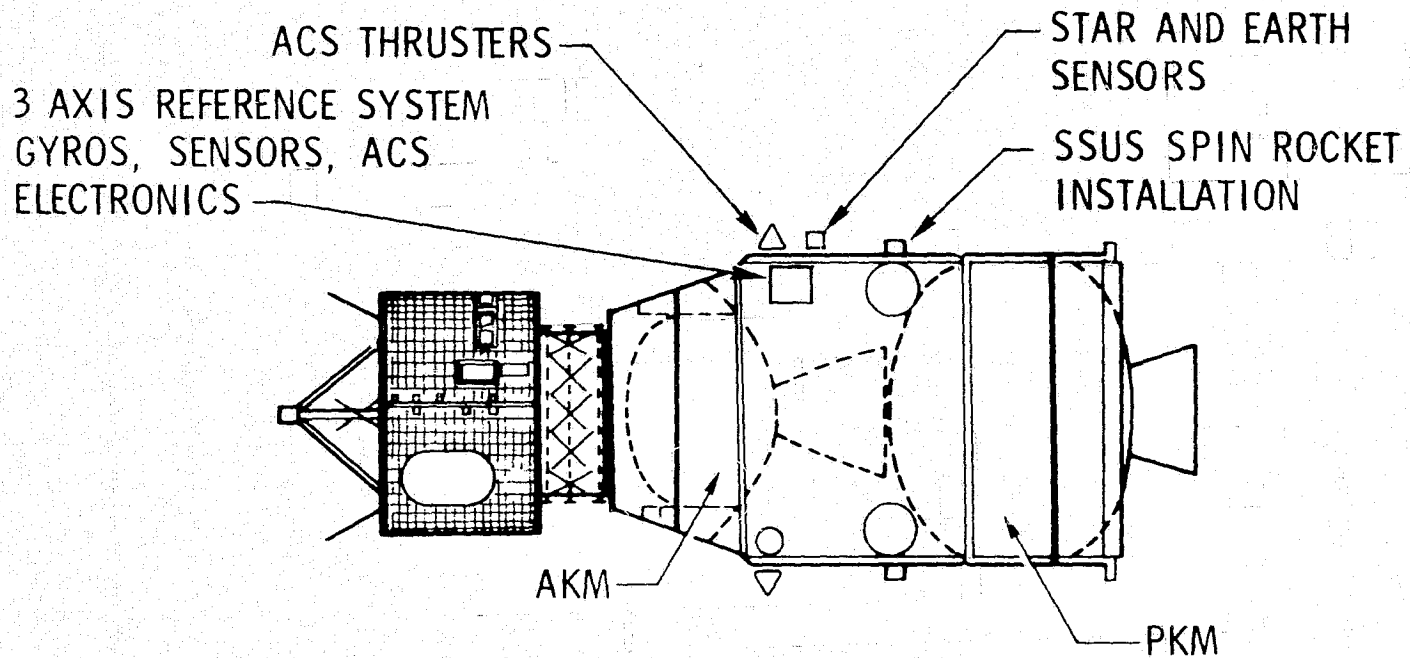

- SPIN STABILIZED SATELLITE
- 3 AXIS INITIAL STABILIZATION OUT OF ORBITER
- 3 AXIS ALIGNMENT OF PKM VECTOR TO STAR/EARTH SENSOR REFERENCE
- SPIN ROCKET FIRING TO SPIN STABILIZE
- ORBITER DEPLOYS SIMILAR TO IUS
- ORBITER RETRO MANEUVER

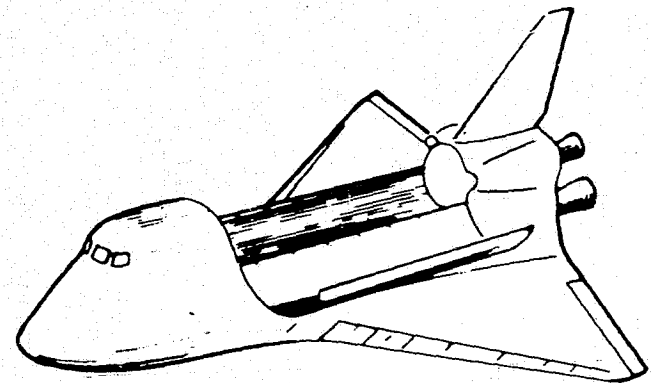
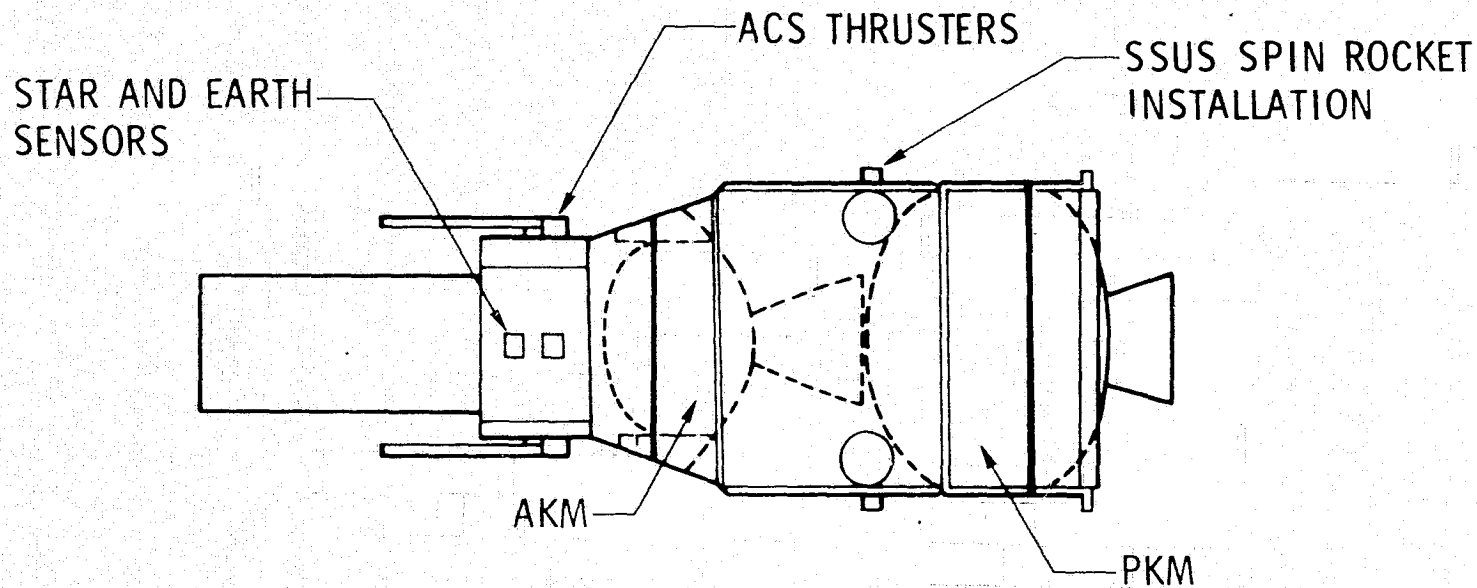

Figure 3-31. SSUS Deployment with a Spin-Stabilized Satellite



- 3 AXIS CONTROLLED SATELLITE
- 3 AXIS INITIAL STABILIZATION OUT OF ORBITER
- 3 AXIS ALIGNMENT OF PKM VECTOR TO STAR/EARTH SENSOR REFERENCE
- SPIN ROCKET FIRING TO SPIN STABILIZE

- ORBITER DEPLOYS SIMILAR TO IUS
- ORBITER RETRO MANEUVER

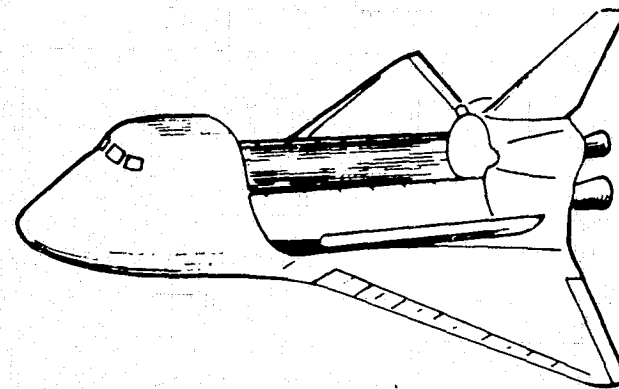

Figure 3-32. SSUS Deployment with a Three-Axis Satellite

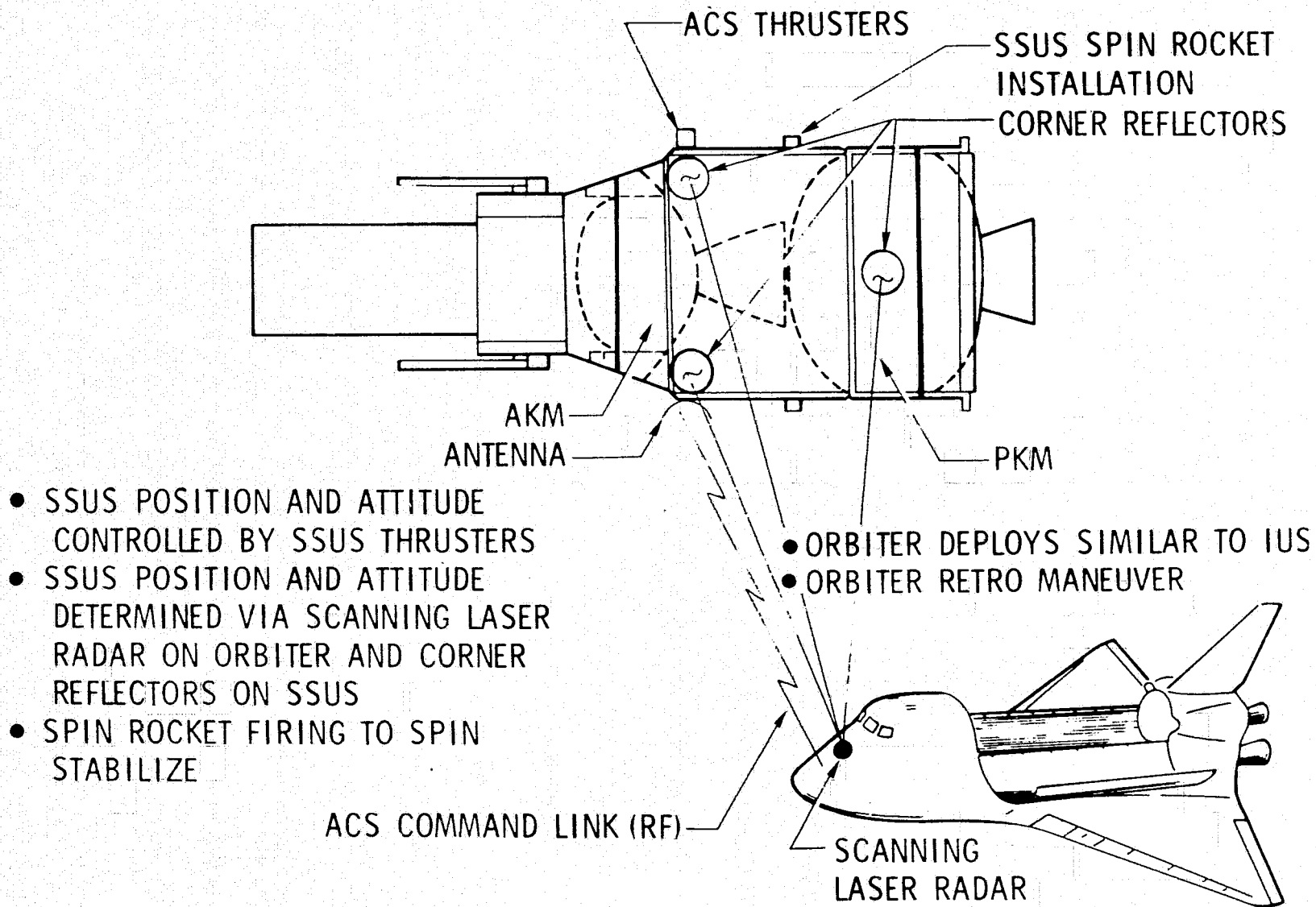
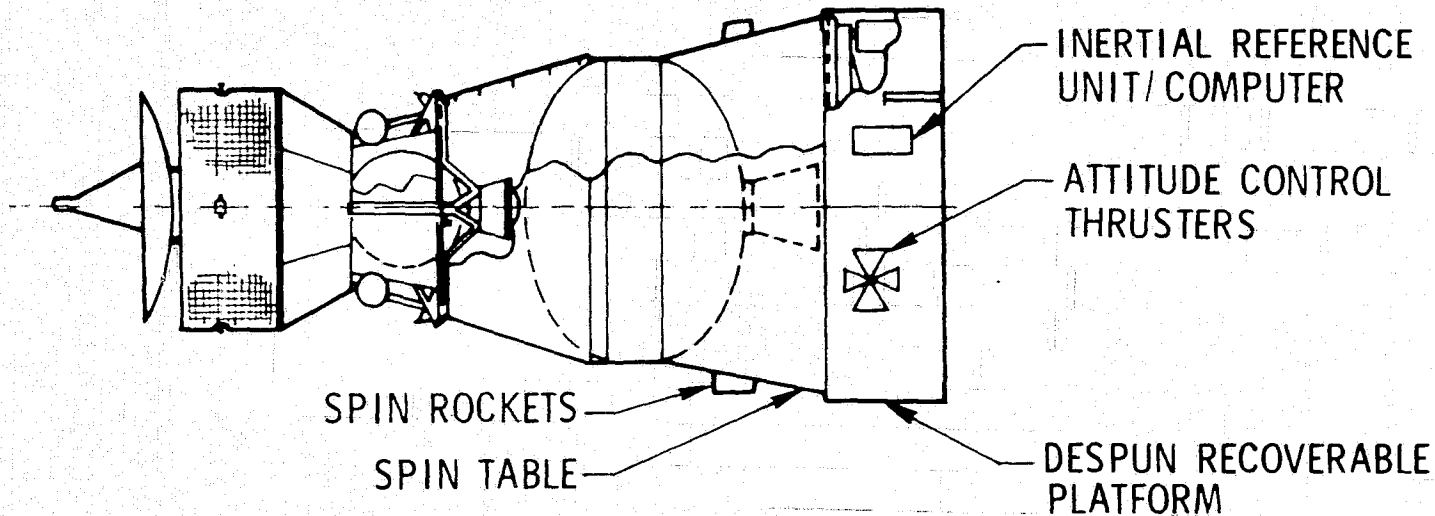

Figure 3-33. SSUS Deployment with Laser Alignment



- SSUS POSITION AND ATTITUDE CONTROLLED BY THRUSTERS ON RECOVERABLE PLATFORM
- SSUS POSITION AND ATTITUDE DETERMINED BY INERTIAL REFERENCE UNIT IN RECOVERABLE PLATFORM
- RECOVERABLE PLATFORM SEPARATED FROM SSUS AND RECOVERED AFTER SSUS SPINUP AND PRIOR TO SSUS PKM IGNITION

- ORBITER DEPLOYS SIMILAR TO IUS
- ORBITER RETRO MANEUVER

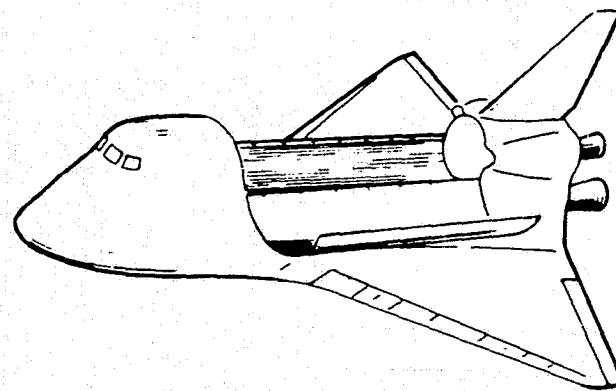

Figure 3-34. SSUS Deployment with a Retrievable Spin Table

2 & 3 STAGE SYSTEMS FOR LESSER REQUIREMENTS

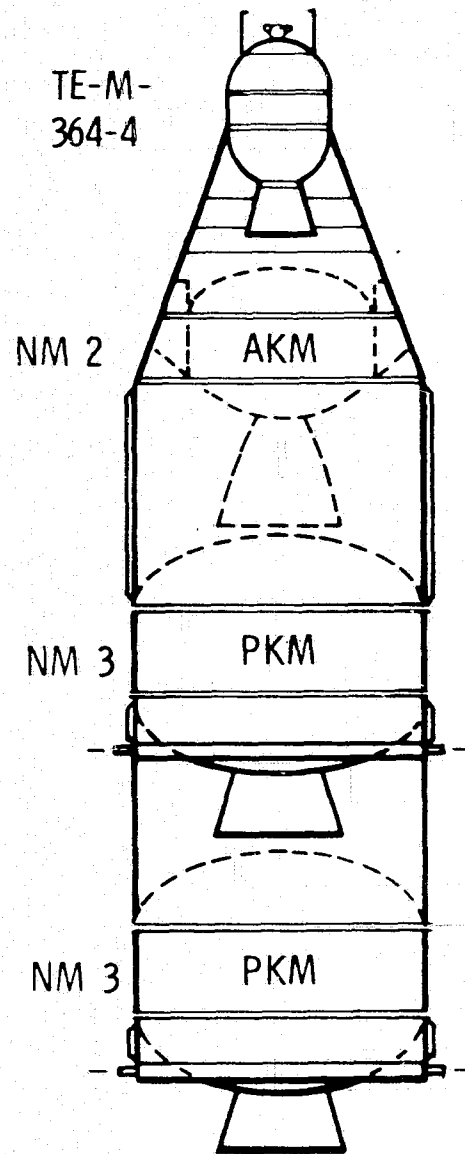

Figure 3-35. SSUS Planetary Four-Stage Configuration

DETERMINATION OF SPIN SYSTEM REQUIREMENTS

A preliminary analysis was conducted to determine the spin system requirements for spinning up the SSUS. The spin system total impulse required was determined as a function of the total spin (roll) moment of inertia of the SSUS and spacecraft. The spin requirements were also determined as a function of the spin rocket moment arm as well as the final spin speed.

The following equation was used to determine the spin system impulse requirements:

$$\text{Spin Impulse} = \frac{2 I_s \omega}{d}$$

where

I_s = Spin moment of inertia, slug-ft²

ω = Final spin rate, rad/sec

d = Diameter between the spin nozzles, ft

In addition, the solid propellant required for solid spin rockets was computed, assuming an I_{sp} of 200 sec. The spin impulse required and spin propellant weight required are presented in Figure 3-36.

As a matter of interest, the sizing for a cold-gas spin system was investigated for a nitrogen system with a 4000 psia storage pressure. The following equations were used in sizing the cold-gas spin system:

$$W = \frac{\text{Spin Impulse}}{I_{spG}}$$

$$P = \frac{12 \times W \times RT}{V}$$

5

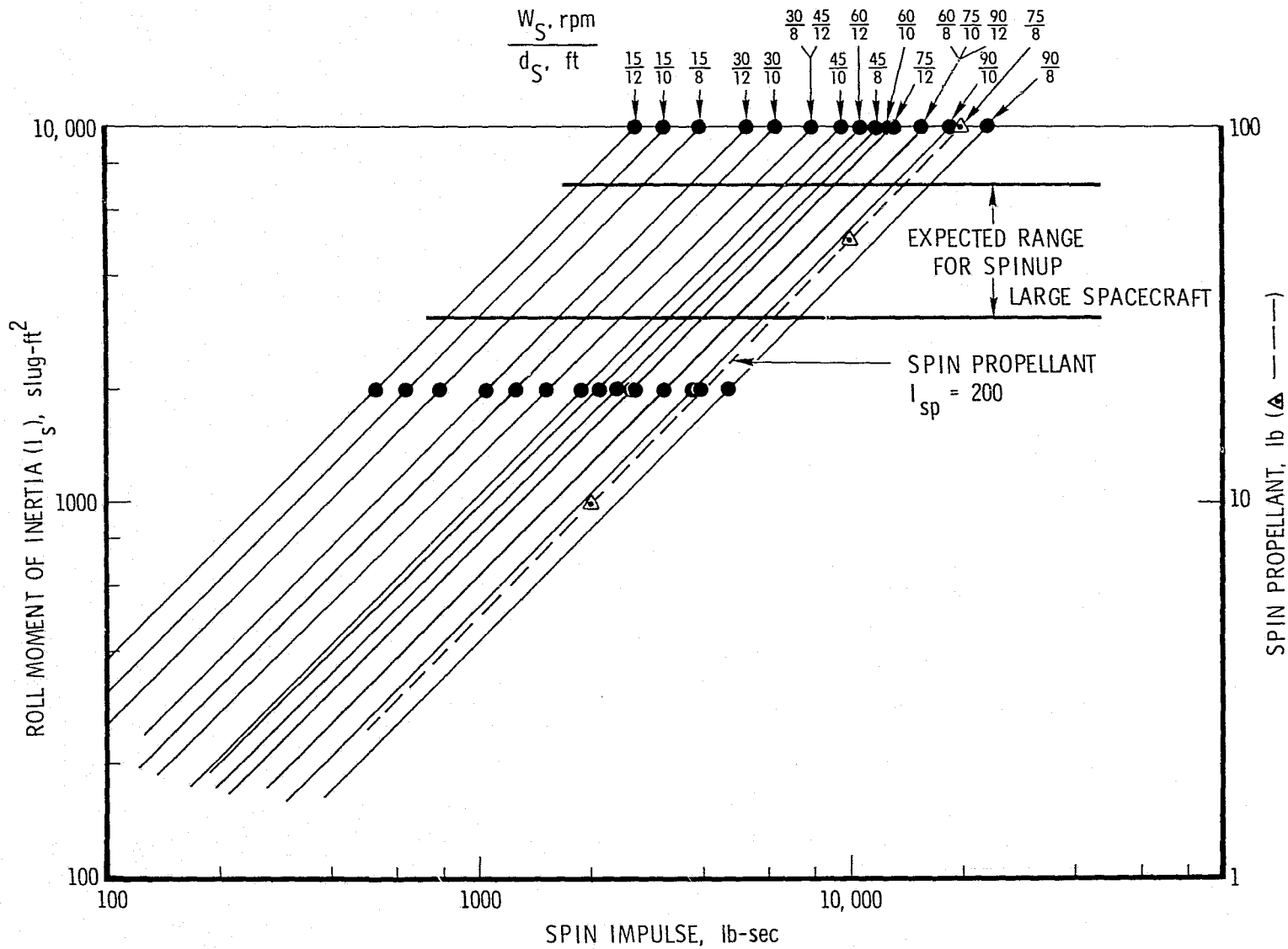

3-171

Figure 3-36. Spin Impulse Requirements Versus Roll Moment of Inertia

where

W = Gas weight, lb

Impulse = Spin total impulse required

I_{spG} = Gas specific impulse, 60 sec (nitrogen)

P = Gas pressure, psia

R = Gas constant, 55.2 ft/°F (nitrogen)

T = Gas temperature, 530° F absolute

V = Gas volume, in.³

Presented in Figure 3-37 are the nitrogen weight and storage bottle diameter required as a function of spin impulse required.

It is also recommended that the spin rockets be positioned such that they be in a plane that contains the configuration center of gravity to preclude excessive spin attitude shift during spinup. The number of spin rockets for the configuration should be on the order of six to eight nozzles.

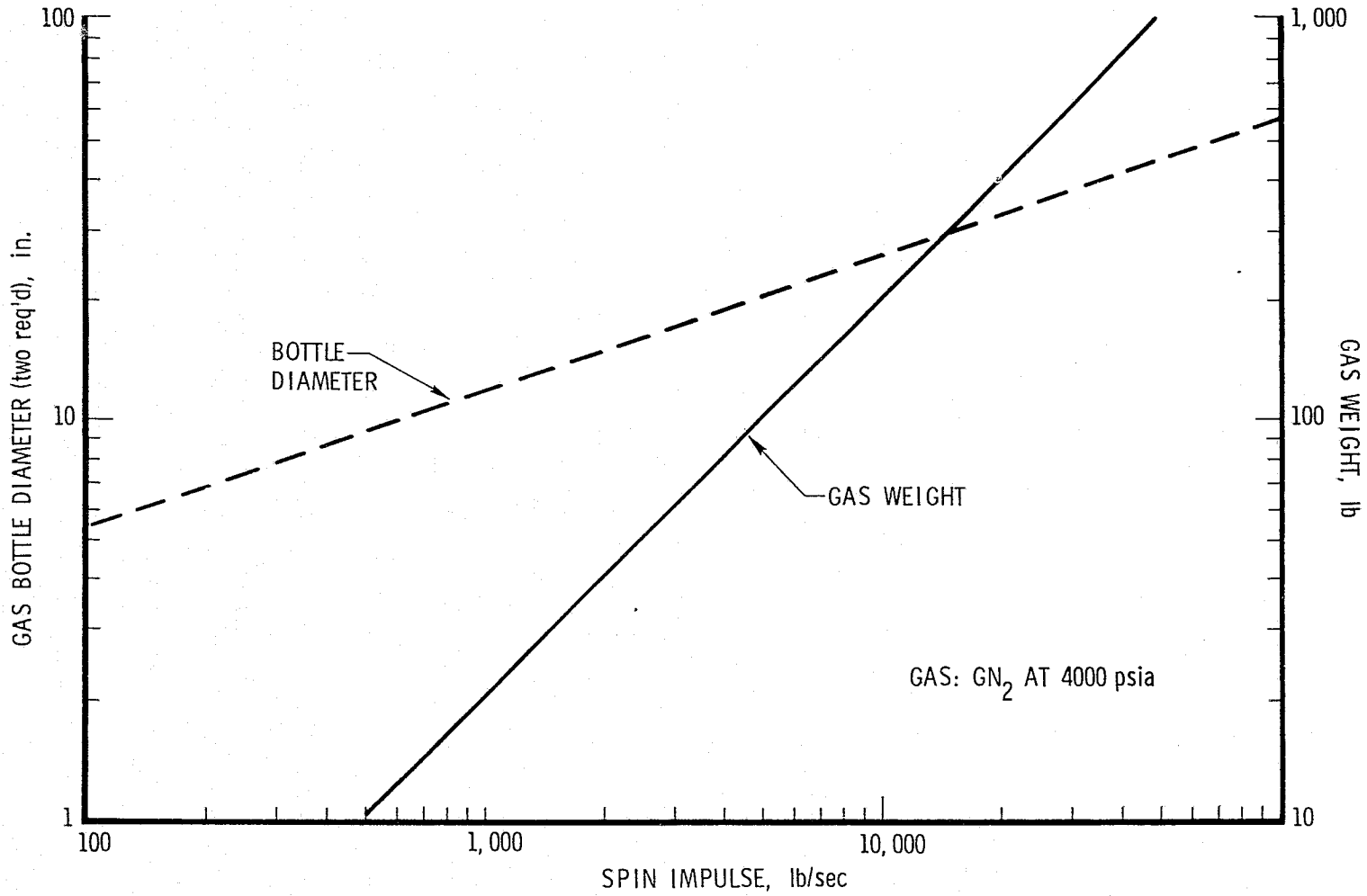

Figure 3-37. Cold-Gas Spin System Weight and Bottle Diameter

3.10 SAFETY ANALYSIS

3.10.1 Objective and Approach

The objective of the safety analysis was to evaluate the feasibility of the SSUS concept from a safety standpoint. This was done by considering the design requirements that might be needed to reduce the possible hazards to an acceptable level. The approach used was to (1) define requirements such as operational procedures and redundancy to assure that there will be a low probability of a hazardous situation occurring, and (2) if a failure should occur, to define possible alternate backup approaches to eliminate the hazardous condition to the Orbiter.

Two configurations of the SSUS were covered in this analysis. The first one, designated the Spin-Before-Deploy System, uses a pallet-mounted spin table to spinup the SSUS while it is still attached to the pallet. With the second, designated the Spin-After-Deploy System, the SSUS is deployed and then spunup by an SSUS on-board spinup device.

In the review of the hazards for these two systems, the safety problems to the SSUS itself, which arise from the spinning motion, were not considered. Many spinning satellites have been flown and extensive studies have been made of spinning satellites, and it was considered that this experience should assure that vehicle requirements for this possible effect would be adequately incorporated into the final design so that safety aspects would be minimal. Therefore, in this hazards analysis, the situations addressed are primarily those which are the basis for design and operational requirements covering the unique features associated with the spinup and deployment of the vehicle using a tiltup system.

3.10.2 Spin-Before-Deploy System

3.10.2.1 Hazard Analysis

The initial analysis activity consisted of identifying the energy sources associated with the SSUS which are peculiar to the preseparation spinup feature of this vehicle. The energy sources are:

- a. Batteries in the tiltup system
- b. Electric motors in the tiltup system

- c. Batteries in the spinup system
- d. Electric motors in the spinup system
- e. Release devices in the spinup system and spin system release
- f. ΔV system (springs were used in this design)
- g. SSUS movement (rotational and translational motion)

A list of safety-critical situations which could result from the above listed hazard sources is shown in Table 3-31.

All of the critical safety events/operations indicated are for the on-orbit case; ground activities were not included since:

- a. Tests of the spin table and initial spin tests of the SSUS for balancing purposes will be performed at some remote facility. The hazards associated with this type of activity are known and can be adequately handled from a safety standpoint.
- b. Testing of the SSUS-peculiar equipment while in the Orbiter will be limited to those activities for normal checkout of ordnance devices, electrical circuits, etc. No spinup of the SSUS on the ground will occur while it is attached to the Orbiter.

The following discussion presents each of the situations from Table 3-31 in terms of cause and effect and controls that should be implemented so that the residual hazards are acceptably low. Each situation is keyed to the listing in the table; i. e., A(1), B(1), B(2), etc.

3.10.2.1.1 A(1) Failure of Retention Clamp or Retractor

3.10.2.1.1.1 Discussion

Failure of the retention device(s) to release the SSUS could be caused by a lack of power to the device or by failure of the device. A retention device failure to release would result in mission abort.

3.10.2.1.1.2 Controls

The retention device should be redundant. A suggested design is to use retention devices which are released by motorized retractors with a pyrotechnic-actuated backup system which would permit release if the

Table 3-31. Hazardous Situations

- A. RELEASE RETENTION DEVICE
- (1) Failure of retention clamps or retractors
- B. TILT-UP OPERATION
- (1) Failure of actuator drive (SSUS stays in initial position or at some intermediate point).
 - (2) Movement of the Orbiter during tilt-up
 - (3) Structural failure of tilt system
 - (4) Failure of tilt-lock mechanism
 - (5) Inadvertent activation of SSUS systems
- C. SPIN-UP
- (1) Spin drive system failure
 - (2) Orbiter movement
 - (3) Excessive SSUS wobble
 - (4) Static electricity buildup and discharge
 - (5) Debris scatter
 - (6) Overspeed condition and/or no shutdown
 - (7) Structural failure of support systems, equipment or hold down systems etc.
 - (8) Inadvertent activation of SSUS systems
- D. SSUS RELEASE
- (1) No release or partial release
 - (2) Debris scatter
 - (3) Inadvertent activation of other SSUS systems
 - (4) Orbiter movement
- E. DEPLOYMENT
- (1) Excessive SSUS wobble
 - (2) ΔV system does not function
 - (3) Orbiter movement during deployment
 - (4) Inadvertent activation of SSUS systems
- F. RETRACT TILT-UP MECHANISM
- (1) Partial or no retraction
- G. BACKAWAY MANEUVER
- (1) Erroneous movement of Orbiter

motorized retractor fails. The motorized units also make it possible to reactivate the retention device if this action is required in event of an abort.

Switches could be used to provide status indication to caution and warning (C&W) systems.

Motorized retractors (if used) would be locked out until enabled.

Discrete commands will be required to activate retention devices.

Consideration should also be given to making the tilt mechanism "free wheeling" so that without power to the motor, the RMS can (1) tilt the SSUS to its operational position, (2) retract the spin-table mechanism after release of the SSUS, or (3) retract with the SSUS attached.

The tilt position will be monitored during the tilt operation and C&W indication provided for attainment of planned orientation.

3.10.2.1.2 B(1) Failure of Tiltup Mechanism

3.10.2.1.2.1 Discussion

Failure of the tiltup mechanism to attain planned orientation could be caused by failure of the power source (electric motors) or the drive mechanism. The effect of this type of failure would be that the SSUS could not be deployed as planned. The mission for the SSUS would be lost, and there may also be an increased hazard associated with landing the Orbiter with the SSUS on-board.

3.10.2.1.2.2 Controls

The tiltup drive motors should be redundant so that if one motor fails, the backup system will operate.

It is not considered a requirement that the drive mechanism be redundant because of the high reliability for this type of mechanism based on aircraft use.

The power supply for the tiltup system may be the Orbiter fuel cells. However, a battery could be carried on the pallet with the Orbiter fuel cells as backup.

Provisions have been incorporated so that the spin-table assembly can be jettisoned with the SSUS attached if necessary. Jettisoning is accomplished by releasing the spin-table assembly and using the RMS for removal from the payload bay.

3.10.2.1.3 B(2) Movement of Orbiter During Tiltup

3.10.2.1.3.1 Discussion

Crew error or other unscheduled application of power to the Orbiter propulsion or attitude control system could cause movement of the Orbiter during tiltup. This is a Shuttle responsibility. The effect is that the Orbiter may move enough to cause failure of the mounting system or support structure and/or possible collision of the SSUS and Orbiter. Any damage to the Orbiter may be catastrophic. The Orbiter will tend to rotate as the SSUS is spun up, and this rotational moment will require that the Orbiter attitude control system be active during this phase of the deployment sequence.

3.10.2.1.3.2 Controls

Since this is a safety-critical function, procedures should be established to require at least two logic steps to enable dynamic systems of the Orbiter during the entire deployment.

Unscheduled application of power will be controlled by the design requirement that no two procedural errors or no single failure of a dynamic system will create an accident potential for the Orbiter or crew.

The mounting system and support structure will be designed for any anticipated loads.

The SSUS will be in a safe condition during the tiltup operation.

3.10.2.1.4 B(3) Structural Failure

3.10.2.1.4.1 Discussion

Structural failure to the tiltup system and its supporting structure during ascent flight would cause improper operation of the system. The effect of this situation is that the SSUS may not be able to be moved to the spin attitude or that collision will occur with the Orbiter structure.

3.10.2.1.4.2 Controls

All SSUS structure, latches, components, etc., should be designed for all anticipated load conditions, including crash loads. The on-orbit loads will not approach the crash loads.

The system is designed so that the SSUS and spin system can be jettisoned if necessary.

3.10.2.1.5 B(4) Failure of Tilt-Lock Mechanism

3.10.2.1.5.1 Discussion

The tiltup system will be designed to pitch the SSUS to a given attitude for separation. For a failure such that the tiltup does not terminate as planned, the clearance volume may be violated. The effect is a possible collision of the SSUS with the Orbiter structure.

3.10.2.1.5.2 Controls

A backup stop should be designed into the system to preclude the collision of the SSUS and Orbiter. Tilt-locking brakes or other devices should be incorporated into the tilt mechanism. The tilt-locking system should also be usable if the tilt operation is performed by the RMS. The tilt-locking system should be designed so that it can be redundantly released.

3.10.2.1.6 B(5) Inadvertent Activation of SSUS Systems

3.10.2.1.6.1 Discussion

The SSUS should be in a dormant state while in or near the Orbiter. Activation of the propulsion system or ACS could cause collision with the Orbiter. Activation of an ordnance device may also create a hazard or contaminate the payload bay.

3.10.2.1.6.2 Controls

No single failure of a dynamic system will create an accident potential for the Orbiter or crew.

At least two logic steps will be required to enable dynamic systems.

Redundant RF links should be provided for ordnance, propulsion, and ACS thruster safe-inhibit command from Orbiter.

System design should ensure there is no electrical power to critical functions until after separation.

Enabling of the arming bus for critical functions should not occur until safe separation is attained.

3.10.2.1.7 C(1) Spin-Drive System Failure

3.10.2.1.7.1 Discussion

The spin-drive system may not operate due to power failure or due to a mechanical failure such as a bearing. A power failure to the spin table would result in a mission abort with the SSUS being returned to its stowed position. A mechanical failure, such as a shattered bearing, could cause excessive vibration to be induced into the SSUS or into the Orbiter. A frozen bearing could cause damage to the SSUS due to deceleration forces. Another possible hazard source is that associated with debris being caught between the spin table and the SSUS. This could be caused by debris breaking loose from the spinning vehicle or drive systems or objects being accidentally left in the payload bay during launch preparations.

3.10.2.1.7.2 Controls

The power system to the spin table should be redundant. The backup power source could be the Orbiter fuel cells. The casing of the spin table should be designed to preclude anything that might break loose from the drive system getting caught between any moving parts which would induce loads or vibration into the SSUS. Other safety features should include an rpm indicator and bearing temperature sensors. In addition, a brake system should be installed which is capable of quickly stopping the rotating SSUS while it is attached to the spin table.

Safety procedures will preclude extraneous objects being left in the payload bay which could contribute to this situation.

3.10.2.1.8 C(2) Orbiter Movement During Spinup

See B(2). The effect of Orbiter movement during spinup may be catastrophic in this phase of operations because of the effect that such movement may have on the spinning vehicle while it is still attached to the spin table. However, preliminary findings from the Rockwell International study on SSUS/Orbiter integration show no apparent problems in this area.

3.10.2.1.9 C(3) Excessive SSUS Wobble

3.10.2.1.9.1 Discussion

SSUS wobble during spinup can result from installation misalignment and mass imbalance. Mass imbalance can be caused by errors in balancing the vehicle, liquid sloshing effects, and failure of mounts for components or holddown systems for deployable components, etc. These failure causes will be further discussed under C(7).

If the satellite is unbalanced for any reason relative to its bearing axis, this axis will attempt to perform a steady-state coning motion around the angular momentum vector while it is on the spin table. This could result in loads being created in the drive mechanism and support structure.

3.10.2.1.9.2 Controls

Installation errors will be handled through procedural controls at the launch site.

The vehicle will be balanced to the extent that is possible on the ground. This has generally been adequate so that the wobble in spin-stabilized satellites has been relatively minor, particularly in relation to the clearances available for this situation and the limited time period during which wobble could be a safety concern.

Design controls should include sensors to detect any significant wobble while on the spin table or loads on the spin table. These sensors should be monitored as the rpm are increased in increments to detect approach to a possibly dangerous threshold value. The spin-table braking system would then be used to stop the rotating SSUS if a dangerous situation was detected.

3.10.2.1.10 C(4) Static Electricity Buildup and Discharge

3.10.2.1.10.1 Discussion

Motion processes are an obvious source of static electricity. However, the positive and negative charges must be accumulated if a voltage is to be built up. To cause a problem, an accumulated charge must discharge. If sensitive elements such as squibs, detonators, vapors, etc., are protected so they are not part of the discharge path, no problems will result.

3.10.2.1.10.2 Controls

The design of the spin-table system, including the selection of materials, should be thoroughly reviewed from the standpoint of generation of static electricity. Thorough grounding to prevent the buildup of high voltages and good design from the standpoint of locating sensitive components and selection of materials will reduce or eliminate this possible problem.

3.10.2.1.11 C(5) Debris Scatter

3.10.2.1.11.1 Discussion

A spinning SSUS or spin table is a possible energy source for objects that might have broken loose during ascent flight or during the spinup operation. Tangential velocity in the 18 to 24-ft/sec range is possible. While it is not apparent that velocities of this magnitude could create significant damage structurally to the Orbiter, it is possible that such debris could affect other equipment items in the payload bay area. Such action would have varying effects on the mission and Orbiter safety.

3.10.2.1.11.2 Controls

All parts of the SSUS and spacecraft which will be spun up should be designed with large safety factors. This should also be a design requirement for the "despun" section components (if any) on the spacecraft, since a failure of the connecting element could cause the "despun" section to rotate.

Proper procedures will assure that nothing is left in the payload bay which could be thrown by a rotating SSUS.

3.10.2.1.12 C(6) Overspeed Condition and/or No Shutdown

3.10.2.1.12.1 Discussion

Overspeed of the spin table could result in excessive loads being imposed on the vehicle and spin-table components. This could result in failure of mounting brackets and support structure which could induce excessive wobble in the SSUS or vibration into the Orbiter. Both could be catastrophic to the Orbiter.

3.10.2.1.12.2 Controls

Redundant speed control should be provided plus a method of cutting off the power to the spin table.

3.10.2.1.13 C(7) Structural Failure of Support Systems, Equipment Mounts, and Hold-Down Systems for Deployable Objects

3.10.2.1.13.1 Discussion

The entire vehicle will be designed to withstand the loads imposed during the ascent phase of flight and spinup. However, structural failures are possible. Any structural failure would jeopardize the SSUS and/or Orbiter during the spinup operation and would therefore be the basis for a mission abort.

3.10.2.1.13.2 Controls

Proper design should prevent this failure from occurring.

Structural failures are likely to be detected in the system checkout procedures prior to spinup and by monitoring the vehicles action and/or the spin-table loads during spinup. The system would then be shut-down if a dangerous situation was observed.

3.10.2.1.14 C(8) Inadvertent Activation of the SSUS Systems

See B(5).

3.10.2.1.15 D(1) No or Partial Release of SSUS

3.10.2.1.15.1 Discussion

If the release devices do not operate, a mission abort is dictated. In this case, the separation system will be disarmed, the SSUS retracted into the payload bay, and the mission aborted. A possible failure mode is for all but one or more of the attach points to be released. In this case, the spring action could create a torque on the vehicle which could result in collision of the SSUS and Orbiter.

3.10.2.1.15.2 Controls

The release devices should be redundant and the attach fittings designed to preclude hangups.

Since this appears to be a very safety-critical function, considerations should be given to designing the release system and ΔV system as separate units, so that satisfactory operation of the release system can be verified before the ΔV is imparted to the SSUS. If complete release has not occurred, the mission would be aborted. Sensors in the release system would be required.

In addition, a latching system should be incorporated so that the SSUS can be resecured to the spin table if partial release occurs. The spin-table brake system can then be used to safely stop the spinning SSUS, and it can then be jettisoned or stowed in the payload bay.

3.10.2.1.16 D(2) Debris Scatter

D(3) Inadvertent Activation of Other SSUS Systems

D(4) Orbiter Movement

See previous discussions.

3.10.2.1.17 E(1) Excessive SSUS Wobble

3.10.2.1.17.1 Discussion

Excessive SSUS wobble on release could endanger the Orbiter, since collision is possible. Wobble could be due to misalignment and mass imbalance as previously discussed. In addition, it could be due to asymmetric ΔV or a combination of factors. It is possible, though highly unlikely, that the wobble condition could cause the SSUS or spacecraft to break up at some point while the SSUS is near the Orbiter. In such an event, it is unlikely that the solid propellants aboard the SSUS would go higher order, but it is likely that liquid propellant tanks or other pressure vessels aboard the SSUS and/or spacecraft could burst. In this case, the Orbiter could be exposed to a shrapnel hazard which could be catastrophic.

3.10.2.1.17.2 Controls

The vehicle motion prior to release should be verified to be within proper values (see previous discussion). This should reduce the hazard from this possible problem area with the exception of the asymmetric ΔV imparted by the separation device. To reduce this problem to what is considered an acceptable level, multiple springs will be used to provide the required ΔV . The system should be designed so that the failure of any combination of springs will not induce unacceptable tipoff errors in the spinning SSUS. The springs will be designed for retention on the spin table.

3.10.2.1.18 E(2) ΔV System Does Not Function

3.10.2.1.18.1 Discussion

If the ΔV system does not function, a free, spinning SSUS will be left in the proximity of the Orbiter. In this condition, movement of the Orbiter is critical, since the clearance between the SSUS and spin table is small. Any contact between the SSUS and spin table and the Orbiter could be catastrophic.

3.10.2.1.18.2 Controls

The ΔV system is planned to be a relatively simply, high reliability device consisting of many springs. The failure of any combination of springs should still provide adequate ΔV for clearance of the Orbiter structure. If the ΔV system is separate from the release system, a redundant control system should be provided.

If this situation occurs, a backup action would be to use the proposed relatching system between the SSUS and spin table and then to stop the SSUS rotation. In this case, the mission could not be completed.

Other approaches could be considered which would not mean loss of the mission with this type of situation. They include (1) designing the spin table so that it can be moved to provide adequate clearance so that Orbiter maneuvering is feasible to attain required separation, (2) using an SSUS on-board system such as small rocket motors to provide a backup ΔV , or (3) using the Orbiter's on-board propulsion to move the Orbiter away from the spinning SSUS.

3.10.2.1.19 E(3) Orbiter Movement During Deployment

E(4) Inadvertent Activation of SSUS Systems

See previous discussions.

3.10.2.1.20 F(1) Partial or No Retraction of Tiltup System

3.10.2.1.20.1 Discussion

The tiltup mechanism has to be retracted to close the Orbiter doors. Retraction failure could be caused by failure of the tilt-lock mechanism to release and failure of the drive system. Failure to close the doors would be catastrophic.

3.10.2.1.20.2 Controls

The tilt-lock release mechanism should be made redundant to assure release.

Failure of the drive system during retraction could be controlled through the use of a "free wheeling" system which would permit the RMS to be used to retract the tilt system if necessary.

The entire spin-table assembly can be jettisoned, as previously discussed, in the event that all other measures fail.

3.10.2.1.21 G(1) Erroneous Movement of the Orbiter During Backaway

3.10.2.1.21.1 Discussion

The backaway maneuver will not be initiated until adequate separation distance exists between the Orbiter and the SSUS. Therefore, the Orbiter maneuvers should not be critical.

3.10.2.1.21.2 Controls

Procedural controls will be used to preclude unscheduled movements of the Orbiter.

3.10.2.2 Conclusions on the Spin-Before-Deploy System

Based on the foregoing review, it appears that the following are the greatest hazards for the SSUS-peculiar features:

- a. Debris scatter from the rotating SSUS while it is near the Orbiter
- b. Collision of the SSUS with the Orbiter while on the spin table or after separation because of
 - 1) Erratic motion of the SSUS
 - 2) Hangups on the spin table
 - 3) No ΔV

It is concluded that adequate procedures and designs can be reasonably provided so that the probability of any one of these hazards occurring is acceptably low. In addition, backup actions are generally available for any credible situation, with the exception of a. above, so that, if a dangerous situation occurs, alternate approaches are available for hazard control.

In connection with a. above, no effort was made to evaluate the vulnerability of the Orbiter or objects within the payload that could be exposed to a debris hazard. An analysis may indicate that for all probable debris physical characteristics and velocities, no significant damage is likely.

The special features which should be considered for incorporation into the system include the following:

- a. Separate SSUS and spin-table release and ΔV systems
- b. Relatchable SSUS and spin-table release system
- c. Relatch system for Orbiter and pallet
- d. Spin-table brake system
- e. SSUS and spin-table release indicators
- f. Spin-table rpm monitor
- g. SSUS motion monitor for period while on spin table or spin table load monitor
- h. "Free Wheeling" tilt system
- i. Spin table assembly and pallet separation capability

3.10.3 Spin-After-Deploy System

With this configuration, the SSUS would be deployed using the RMS, and the Orbiter would move away to a safe distance prior to spinup initiation. Therefore, the only energy source that is of interest in this analysis is the spinup system. It is anticipated that this system would use small rocket motors. The possible problems and hazards associated with such a spinup system would be those characteristically associated with this type of device. Since the basic propulsion devices for the SSUS configurations are also solid rocket motors, the incorporation of a SRM spin system should have no significant additional impact on the design requirements or the safety problems.

3.10.4 General Conclusions on SSUS Safety

Of the two possible SSUS configurations considered, the spin-after-deploy system presents the fewest safety problems or concerns. Both

the design and the deployment operations are simple and are not significantly different than for a non-spinning configuration. With this configuration, the spinup occurs when the distance between the Orbiter and the SSUS is sufficiently large, so no appreciable hazard level exists for this operation.

In the case of the spin-before-deploy system, additional design requirements and procedures are considered necessary in order to control many possibly hazardous situations. While none of the design features that are considered necessary for safety reasons are major, they do add an increased level of complexity to the operation of the system. However, it was concluded after this brief study that, contrary to the initial natural reaction to the spin-before-deploy concept, proper design and procedures should reduce the hazards for this concept to levels which are acceptably low.

In this conceptual study, adequate details were not available to perform detailed analyses to define the requirements for safety features. Therefore, before finalization of the requirements for these features, some additional studies are recommended:

- a. A study of separation dynamics versus clearance volume should include the effects of SSUS spin dynamics considering credible failure situations, tipoff errors due to spring ΔV , and possible Orbiter movement and Orbiter dynamics until SSUS clearance of the Orbiter.
- b. A reliability study would verify the need for providing separate SSUS and spin-table release and ΔV systems. The need for separate systems was based on the possibility of a hangup of the SSUS on the spin table. If the system can be designed to essentially preclude the occurrence of such a situation, a more conventional and simpler, integrated release- ΔV system may be adequate.

SSUS SYSTEM COST ESTIMATION

The SSUS geosynchronous system cost estimates were made by utilizing the cost data bank assembled during the performance of the IUS assessment and were completed near the end of the IUS cost estimation activity to the same ground rules where applicable. The depth of detail available in the IUS design assessment was significantly greater than the conceptual SSUS designs which created some problems of interpretation. Compensating factors were the simplicity of the SSUS concept, hardware, and operations through use of the satellite features (although at some cost impact to the satellite, Satellite Operations Control Center, and ground tracking network which is not estimated herein). The adjusted IUS cost data were utilized with complexity factors and engineering judgment to provide SSUS cost estimates. The IUS cost data bank is not reproduced herein due to the sensitivity of these data during the assessment process. These data are available through NASA and Air Force personnel participating in the IUS assessment to qualified persons. Related data on both the liquid and solid propellant IUS options and other pertinent data were also used in the SSUS estimates. All costs are in FY 1976 dollars and exclude fee.

The SSUS cost estimation effort utilized the same contract work breakdown structure (WBS) as that used for the IUS solid propellant stage (Table 3-32). The WBS items described briefly in Table 3-32 were utilized in all SSUS cost tabulations. In certain cases, the next higher WBS will be found tabulated. For example, 3060-System Project Management is utilized in the unit cost data instead of individual listings for 3061-System Engineering and 3062-Support Project Management. In other instances, SSUS WBS items were lumped together due to lack of visibility into the particular SSUS or IUS task sub-breakdown.

The SSUS cost elements are presented by options or by building blocks so as to be applicable either to portions of the mission model or to the total model. Basically, two deployment cradle sizes were costed with optional spin tables, and two sizes of stage structure and auxiliary hardware

Table 3-32. Work Breakdown Structure (Abbreviated)

3000	System - Program Summary of Complex of Hardware, Software, Services	
3010	Vehicle and Integrated Equipment Installed in Orbiter	
3110	Integration and Assembly of SSUS as an Entity, SRM's, Structure, Avionics, ASE	
3412A	AKM - Solid Rocket Motor Apogee	} New Develop. 7 Full Scale R&D - Qual Firings Off-Load Option 3 " " " " "
3412B	PKM - Solid Rocket Motor Perigee	
3412H	Attitude Control (Option)	
3413	Avionics - Separation System, TT&C, Sun and Earth Sensors, Active Nutation Control, Power Supply (Full Avionics Option)	
3414	AKM, PKM, Forward and Aft Skirt Structure	
3610	Airborne Support Equipment - 2 sets of Flight Equipment plus 3rd Qual Set Cradle, Spin Table, Adapters, Supports, Shuttle Interface Equipment	
3020	Training - All Training for Factory, Technical, Ground and Flight Crew	
3030	Ground Communication Command and Control - for Basic Ground System (Excludes Ground Tracking Station Network/SOCC Satellite Control of S/C-SSUS/AKM)	

Table 3-32. Work Breakdown Structure (Abbreviated) (Continued)

- 3040 Ground Support Equipment Hardware/Software Required for Manufacture, Transportation, Ground Checkout, Handling Factory, Launch and Landing Site
- 3050 System Test and Evaluation - Integrated System Level Tests on SSUS Vehicle, Interfaces, EMI, Dummy Vehicle, 1st Flight Vehicle and Special Instrumentation
- 3061 Systems Engineering - Integrated Engineering Effort, Dynamics Analyses, Staging Analyses, Modal Survey, Safety Analyses, Reliability, Human Factor
- 3062 Project Management - Technical and Administrative, Planning, Organizing, Directing, Control of Program
- 3070 Data - Deliverable Data, Reports
- 3080 Operational Site Activation - Activate, Support SSUS Facilities, Includes 100K Class Clean Balancing, Alignment and Assembly Facility at Launch Site
- 3090 Flight Support Operations and Services - Mission Planning, Launching, Airborne Assembly Checkout
- 9950 First Destination Transportation - Packaging and Shipping from Factory to Launch Site

are required to match the cradles. Several solid rocket motors are required with full and partial propellant loadings to be used in various combinations in the large and small stages to match satellite mission requirements. Ground and flight operations are essentially identical for all options.

The SSUS cost estimations for the several RDT&E options include the validation, full-scale development program phase periods, and investment. The WBS 3061-System Definitization includes extensive dynamic analyses, modal surveys, staging analyses, and safety and Shuttle interface studies. The WBS 3610-Airborne Support Equipment includes investment in two flight sets of all cradle and spin-table designs required by each option plus a third flight set for development and qualification test which can later be utilized by the Shuttle Avionic Integration Laboratory. WBS 3080-Operational Site Activation includes a launch site facility with 100,000-class cleanliness and equipped with a large spin-balance machine where the SSUSs and satellites are dynamically spin balanced, aligned, and assembled; undergo necessary integration checkout; and are installed in the cradle spin table. Approximately \$2 million was estimated for the facility. WBS 3090-Flight Support Operations and Service includes the first flight vehicle and first flight vehicle special instrumentation. The first flight vehicle would consist of a large and small SSUS for the geosynchronous family option and one small SSUS for the EO-57A-only class case.

Table 3-33 summarizes the SRM RDT&E and unit costs. The WBS 3412A/3412B-AKM/PKM Solid Rocket Motors RDT&E provides for a minimum of seven full-scale development and qualification test firings for new motors and three full scale qualification firing for major off-loaded designs for the new motors. Existing motors utilized all appear to have sufficient experience with off-loaded applications, particularly in the numerous TE-M-364 series motors so that no additional RDT&E is specified.

Tables 3-34 and 3-35 summarize the WBS 3413-Avionics costs which were added to the SSUS system. The minimum avionics case provided equipment, TT&C antennas, cables, separation system, and interface connectors necessary for the SSUS to function as a satellite-dependent

Table 3-33. Solid Rocket Motor Options

		RDT&E	UNIT/YR	
			6	12
WBS 3412A AKM				
EO-09A	NM2 Off Loaded to 3600 lb W _p	1,500.0	190	165
EO-07A	TE-M-364-4 2037 lb W _p	0.0	167	140
AS-05A	TE-M-364-15(-3) 1102 lb W _p	0.0	156	131
EO-57A	TE-M-616 701 lb W _p	0.0	90	75
WBS 3412B PKM				
EO-09A	NM1* Design Point 13,256 lb W _p	7,000.0	260	215
EO-07A	NM1 Off Loaded to 8215 lb W _p	1,639.0	230	195
AS-05A	NM2 Design Point 4000 lb W _p	5,170.0	190	165
EO-57A	NM2 Off Loaded to 2780 lb W _p	1,500.0	180	155
(Note: Of NM2 not developed at 4000 lb for AS-05A EO-57A Developes at Design Point 2780 lb W _p for \$4.5M)				
Planetary	NM3 Design Point 20,250 lb W _p	7,500.0	265	220

* NM 1, 2, 3 New Motor 1, 2, 3

COST FY 76 \$ x 1000 NO FEE

Table 3-34. Minimum Avionics Option

<u>WBS</u>		<u>RDT&E</u>	UNIT/YR	
			<u>6</u>	<u>12</u>
3413	Avionics Module	325.0	40.0	32.0
3413 FB	TT&C Antenna (TT&C System in Payload)	125.0	14.0	10.6
3413 FE	RF Switch & Cables	8.0	1.3	0.8
3413 GC	Wiring, Connectors, etc.	50.0	---	---
3413 GD	Staging Disconnects, 2 Small	9.3	7.7	7.1
3413 GE	Umbilical Connectors	7.7	6.0	5.5
3413 GZ	Separation System, Ordnance, EED's	125.0	10.0	8.0
3413	Avionics Module PKM Stage Only	325	35.0	31.0

COST FY 76 \$ x 100 NO FEE

Table 3-35. Complete Avionics Option

<u>WBS</u>		<u>RDT&E</u>	<u>6</u> UNIT/ YR	<u>12</u>
3413	Avionics Module	9947.8	1140	995
3413A	Integration and Assembly	250.0	20	17
3413C	Navigation Subsystem - Sun Sensors Horizon Sensors Assoc. Electronics	2014.2	259	227
3413D	Control Subsystem - Rate Gyros Active Nutation Control System, Sensor, Electronics	2539.9	221	193
3413F	Telemetry, Tracking & Command	4500.0	369	322
3413G	Electrical Power Subsystem	643.7	221	193
3060	△PM		050	43

CGST FY 76 \$ x 100 NO FEE

system. The complete avionics case provides all the equipment necessary for the SSUS to function independent of the satellite (except for a satellite mass simulation model in the absence of a real satellite). This equipment includes an electric power system, a complete TT&C system, active nutation control, sun and horizon sensors, rate gyros, and associated electronics. To this complete avionics case, a WBS 3412H-Attitude Control System (complete) must be added. This SSUS design option is thus able to accept and execute all commands transmitted by the Orbiter and the ground tracking network through final satellite deployment, despin, and on-station operation. This full-capability option probably approaches the cost of an inertially guided three-axis stage, since the required sun and earth sensors, nutation electronics, etc., are interchanged costwise for an inertial measurement unit and general purpose computer with most other avionics and ACS similar. However, the thrust vector control (TVC) is not required on the SSUS.

The SSUS RDT&E and unit costs estimates are also shown for the following options:

- a. Two-stage geosynchronous family with minimum avionics and satellite dependent, consisting of a large SSUS with motor options for EO-09A, EO-07A, AS-05A, and other large geosynchronous payloads including a large cradle and spin table; a small SSUS with motor options for EO-57A-size payloads and a dual, small spin-table cradle (Table 3-36).
- b. Two-stage geosynchronous Delta class with minimum avionics and satellite dependent, EO-57A-type-only payloads, small SSUS with motor options and a dual small spin-table cradle (Table 3-37).
- c. An autonomous two-stage geosynchronous family having complete avionics and satellite independent; otherwise the same as a. above (Table 3-38).
- d. An autonomous two-stage geosynchronous Delta class EO-57A-type-only payload, having complete avionics and satellite independent; otherwise the same as b. above (Table 3-39).
- e. A single-stage PKM-only geosynchronous family with minimum avionics; otherwise the same as a. above (Table 3-40).

Table 3-36. Geosynchronous Family, SSUS Two-Stage System, Minimum Avionics, Satellite-Dependent Cost Estimate

<u>WBS</u>	<u>ITEM</u>	<u>RDT&E</u>	<u>REMARKS</u>
3000	SSUS 2-Stage	65,324.0	
3010	Integration & Assembly	307.0	
3412A	AKM - NM2 O/L 3600 lb TE364-3, 4 & 616	1,500.0 0.0	TE Motors Exist
3412B	PKM - NM1 13250 lb NM1 C/L 8215 lb NM2 4000 lb NM2 O/L 2730 lb	7,000.0 1,639.0 5,170.0 1,500.0	New Developments
3413	Avionics	525.0	Minimum Avionics, Omni Antenna Separation System, Cable
3414	Structure	3,438.2	Single Spin Table Cradle
3610	Airborne Support Equipment	15,750.0	Dual Spin Table Cradle
3020	Training	750.0	2 Sets, 3rd Qual Each
3030	Ground Comm. Command & Control	400.0	

Table 3-36. Geosynchronous Family, SSUS Two-Stage System, Minimum Avionics, Satellite-Dependent Cost Estimate (Continued)

<u>WBS</u>	<u>ITEM</u>	<u>RDT&E</u>	<u>REMARKS</u>
3040	Ground Support Equipment	1,853.5	
3050	Systems Test & Evaluation	5,800.0	Includes 1st Flight Vehicle & Spec. Instrumentation 1 each Size (2)
3061	Systems Engineering	10,004.6	
3062	Systems Project Mgmt.	3,904.0	
3070	Data	166.7	
3080	Operations Site Activation	3,510.0	Includes 100K Class Clean Balance & Align. Assy. Facility
3090	Flight Support Operations & Service	2,000.0	
9950	First Destination Transportation	106.0	

CGST FY 76 \$ x 1000 NO FEE

Table 3-37. EO-57A/SSUS Two-Stage System Only, Minimum Avionics,
Satellite-Dependent Cost Estimate

<u>WBS</u>	<u>ITEM</u>	<u>RDT&E</u>	<u>REMARKS</u>
3000	SSUS 2-Stage	35,805.5	
3010	Integration & Assembly	403.9	
3412A	AKM - TE-M-616	0.0	Existing SRM
3412B	PKM - NM2 2780 lb Size	4,500.0	New Development
3413	Avionics	325.0	
3414	Structure	1,719.1	
3610	Airborne Support Equipment	10,500.0	Dual Spin Table Cradle 2 Sets, 3rd Qual
3020	Training	508.0	
3030	Ground Comm. Command & Control	320.0	
3040	Ground Support Equipment	1,235.7	
3050	Systems Test & Evaluation	2,900.0	Includes 1st Flight Vehicle & Spec. Instrumentation

Table 3-37. EO-57A/SSUS Two-Stage System Only, Minimum Avionics,
 Satellite-Dependent Cost Estimate (Continued)

<u>WBS</u>	<u>ITEM</u>	<u>RDT&E</u>	<u>REMARKS</u>
3061	Systems Engineering	5,716.9	
3062	Systems Project Mgmt.	2,602.7	
3070	Data	111.1	
3080	Operations Site Activation	3,310.0	Includes 100K Class Clean Balance & Alignment Assembly Facility
3090	Flight Support Operations and Service	1,600.0	
9950	First Destination Transportation	53.1	

COST FY 76 \$ x 1000 NO FEE

Table 3-38. Geosynchronous Family, SSUS Two-Stage System, Complete Avionics, ACS, Satellite-Independent Cost Estimate

<u>WBS</u>	<u>ITEM</u>	<u>RDT&E</u>	<u>REMARKS</u>
3000	SSUS 2-Stage	36,362.8	
3010	Integration & Assembly	1,249.0	
3412A	AKM NM2 O/L 3600 lb TE-364-3, 4 & 616	1,500.0	TE Motors Exist
3412B	PKM - NM1 13256 lb	7,000.0	New Developments
	NM1 O/L 8215	1,639.0	
	NM2 4000 lb	5,170.0	
	NM2 O/L 2780 lb	1,500.0	
3412H	Attitude Control System	2,058.0	TT&C Sun, H/S Sensors, Nutation Control, Power
3413	Avionics	17,408.6	
3414	Structure	3,438.2	
3610	Airborne Support Equipment	13,245.0	Single Spin Table Cradle
3020	Training	750.0	Dual Spin Table Cradle 2 Sets, 3rd Qual Each

Table 3-38. Geosynchronous Family, SSUS Two-Stage System, Complete Avionics, ACS, Satellite-Independent Cost Estimate (Continued)

<u>WBS</u>	<u>ITEM</u>	<u>RDT&E</u>	<u>REMARKS</u>
3030	Ground Comm. Command & Control	320.0	
3040	Ground Support Equipment	3,643.5	
3050	Systems Test & Evaluation	3,900.0	Includes 1st Flight Vehicle and Special Instrumentation
3061	Systems Engineering	11,726.6	
3062	Systems Project Mgmt.	5,342.2	
3070	Data	166.7	
3080	Operation Site Activation	3,310.0	Includes 100 K Class Clean Balancing & Align. Assy. Facility
3090	Flight Support Operations and Service	2,000.0	
9950	First Destination Transportation	106.0	

COST FY 76 \$ x 1000 NO FEE

Table 3-39. EO-57A/SSUS Two-Stage System Only, Complete Avionics,
ACS, Satellite-Independent Cost Estimate

<u>WBS</u>	<u>ITEM</u>	<u>RDT&E</u>	<u>REMARKS</u>
3000	SSUS 2-Stage	51,959.3	
3010	Integration & Assembly	624.9	
3412A	AKM - TE-M-616	0.0	Existing SRM
3412B	PKM - NM2 2780 lb Size	4,500.0	New Development
3412H	Attitude Control System	1,176.0	
3413	Avionics	9,947.8	TT&C Sun, H/S Sensors Nutation Control, Power
3414	Structure	1,719.1	
3610	Airborne Support Equipment	12,000.0	Dual Spin Table Cradle 2 Sets, 3rd Qual
3020	Training	508.0	
3030	Ground Comm. Command & Control	320.0	
3040	Ground Support Equipment	2,435.7	

Table 3-39. EO-57A/SSUS Two-Stage System Only, Complete Avionics, ACS, Satellite-Independent Cost Estimate (Continued)

<u>WBS</u>	<u>ITEM</u>	<u>RDT&E</u>	<u>REMARKS</u>
3050	Systems Test & Evaluation	3,900.0	Includes 1st Flight Vehicle & Spec. Instrumentation
3061	Systems Engineering	6,700.9	
3062	Systems Project Mgmt.	3,052.7	
3070	Data	111.1	
3080	Operations Site Activation	3,310.0	Includes 100K Class Clean Balance & Alignment Assembly Facility
3090	Flight Support Operations	1,600.0	
9950	First Destination Transportation	53.1	

COST FY 76 \$ x 1000 NO FEE

Table 3-40. Geosynchronous Family SSUS System, PKM Only, Minimum Avionics, Satellite-Dependent Cost Estimate

<u>WBS</u>	<u>ITEM</u>	<u>RDT&E</u>	<u>REMARKS</u>
3000	SSUS 2-Stage	61,256.4	
3010	Integration & Assembly	686	
3412A	No AKM	0.0	AKM in Spacecraft
3412B	PKM - NM1 13250 lb	7,000.0	New Development
	NM1 O/L 8215 lb	1,639.0	
	NM2 4000 lb	5,170.0	
	NM2 O/L 2780 lb	1,500.0	
3413	Avionics	475.0	Minimum Avionics, Omni-Antenna Sep. System, Cables
3414	Structure	2,407.0	Single Spin Table Cradle
3610	Airborne Support Equipment	15,750.0	Dual Spin Table Cradle 2 sets, 3rd Qual each
3020	Training	750.0	
3030	Ground Comm. Command & Control	400.0	

Table 3-40. Geosynchronous Family SSUS System, PKM Only, Minimum Avionics,
Satellite-Dependent Cost Estimate (Continued)

<u>WBS</u>	<u>ITEM</u>	<u>RDT&E</u>	<u>REMARKS</u>
3040	Ground Support Equipment	1, 653.5	
3050	Systems Test & Evaluation	5, 400.0	Includes 1st Flight Vehicle & Spec. Instrumentation 1 each Size (2)
3061	Systems Engineering	9, 129.6	
3062	Systems Project Mgmt	3, 513.6	
3070	Data	166.7	
3080	Operations Site Activation	3, 510	Includes 100K Class Clean Balance & Alignment Assembly Facility
3090	Flight Support Operations and Service	2, 000	
9950	First Destination Transportation	106	

COST FY 76 \$ x 1000 NO FEE

- f. A single-stage PKM-only geosynchronous Delta class EO-57A-type-only payload with minimum avionics; otherwise similar to b. above (Table 3-41).

Table 3-42 summarizes these data and shows unit costs.

Tables 3-43 through 3-45 present the unit cost data for these options, and Figure 3-38 shows the major unit cost options versus rate for an 87 1/2 percent learning curve. Conclusions are more easily drawn from these charts. The complete avionic systems have relatively high RDT&E and unit costs which probably approach those of three-axis inertial guidance stages. The minimum avionics satellite-dependent cases, which are the original SSUS concept, are less costly. This is particularly true for the smaller Delta-class payloads in RDT&E, although all have low unit costs, especially the PKM-only cases. To these costs must be added the cost estimate impact for spinning the satellite as provided in the Task I geosynchronous payload model development. These data indicated RDT&E impacts for three-axis satellites of \$2 million to \$6 million per design and \$0.5 million to \$1.5 million per unit for EO-09A, EO-07A, and EO-05A payloads. On the other hand, the cost impacts for a spin-stabilized satellite like EO-57A were negligible. These data together suggest the Delta-class, minimum avionics, two-stage and the PKM cases are the most cost-effective applications of the SSUS concept.

Examination of these cost data suggests a further study of major cost areas in RDT&E (such as the spin-table development) to determine if external spinup or non-spin-table deployment would be more cost effective. Mission model applications which do not require major new solid rocket motor developments are another cost reduction area. A major cost-impact issue is the organization and management of the SSUS system; that is, whether the SSUS should be an add on to several satellite program management systems with a common Orbiter cradle/spin-table interface or whether a separate SSUS management structure should exist to serve a wide range of satellite users.

Table 3-41. EO-57A/SSUS Single-Stage System, PKM Only, Minimum Avionics, Satellite-Dependent Cost Estimate

<u>WBS</u>	<u>ITEM</u>	<u>RDT&E</u>	<u>REMARKS</u>
3000	SSUS 2-Stage	34,118.6	
3010	Integration & Assembly	343.0	
3412A	No AKM	0.0	AKM in Spacecraft
3412B	PKM - NM2 2780 lb Size	4,500.0	New Development
3413	Avionics	275.0	Minimum Avionics Omni-Antenna , Sep. System, Cables
3414	Structure	1,203.4	
3610	Airborne Support Equipment	10,500.0	Dual Spin Table Cradle 2-Sets, 3rd Qual
3020	Training	508.0	
3030	Ground Comm. Command & Control	320.0	
3040	Ground Support Equipment	1,135.7	
3050	Systems Test & Evaluation	2,700.0	Includes 1st Flight Vehicle and Spec. Instrumentation

Table 3-41. EO-57A/SSUS Single-Stage System, PKM Only, Minimum Avionics,
 Satellite-Dependent Cost Estimate (Continued)

<u>WBS</u>	<u>ITEM</u>	<u>RDT&E</u>	<u>REMARKS</u>
3061	Systems Engineering	5,216.9	
3062	Systems Project Mgmt.	2,342.4	
3070	Data	111.1	
3080	Operations Site Activation	3,310.0	Includes 100K Class Clean Balance & Align. Assembly Facility
3090	Flight Support Operations and Service	1,600.0	
9950	First Destination Transportation	53.1	

COST FY 76 \$ x 1000 NO FEE

Table 3-42. SSUS Cost Summary

		Two Stage				Perigee Stage Only			
		Geosync. Family		Delta Class		Geosync. Family		Delta Class	
		EO-09A, EO-07A		EO-57A		EO-09A, EO-07A		EO-57A	
		AS-05A, EO-57A		Only		AS-05A, EO-57A		Only	

Satellite Controlled

RDT&E	\$65.8M		\$35.8M		\$61.3		\$34.1M	
Units/Yr.	6/YR	12/YR	6/YR	12/YR	6/YR	12/YR	6/YR	12/YR
EO-09A	1.05	0.90	---	---	0.68	0.58	---	---
EO-07A	1.00	0.86	---	---	0.65	0.56	---	---
AS-05A	0.95	0.82	---	---	0.61	0.53	---	---
EO-57A	0.81	0.70	0.81	0.70	0.56	0.49	0.56	0.49

Autonomous AKM

Avionics

RDT&E	\$86.9M		\$52.0M		N/A		N/A	
Units/Yr	6/YR	12/YR	6/YR	12/YR				
EO-09A	2.62	2.27	---	---				
EO-07A	2.57	2.57	---	---				
AS-05A	2.52	2.19	---	---				
EO-57A	2.38	2.07	2.38	2.07				

COST FY 76 \$M NO FEE

Table 3-43. SSUS Two-Stage, Minimum Avionics, Satellite-Dependent Unit Costs

	RATE/YR	EO-09A		EO-07A		AS -05A		EO-57A	
		6	12	6	12	6	12	6	12
3000	SSUS	1051	900	998	855	947	816	813	699
3110	I&A	50	44	50	44	50	44	50	44
3412A	AKM								
	NM2 O/L	190	165						
	TE364-4			167	140				
	TE364-3					156	131		
	TE616							90	75
3412B	PKM								
	NM1	260	215						
	NM1 O/L			230	195				
	NM2					190	165		
	NM2 O/L							180	155
3412H	ACS	NONE							
3413	Avionics	40	32	40	32	40	32	40	32
3414	Structure	288	252	288	252	288	252	230	201

Table 3-43. SSUS Two-Stage, Minimum Avionics, Satellite-Dependent Unit Costs (Continued)

	RATE/YR	EO-09A		EO-07A		AS-05A		EO-57A	
		6	12	6	12	6	12	6	12
3046	GSE Maintenance	8	3	8	3	8	3	8	3
3060	Sys. Proj. Mgmt.	55	48	55	48	55	48	55	48
3090	Flight Support	150	131	150	131	150	131	150	131
9950	Transportation	10	10	10	10	10	10	10	10

COST FY 76 \$ x 1000 NO FEE

Table 3-44. SSUS Two-Stage, Complete Avionics, Satellite-Independent Unit Costs

	RATE/ YR	EO-09A		EO-07A		AS-05A		EO-57A	
		6	12	6	12	6	12	6	12
3000	SSUS	2619	2271	2566	2226	2515	2187	2381	2071
3110	I&A	60	50	60	50	60	50	60	50
3412A	AKM								
	NM2 O/L	190	165						
	TE 364-4			167	140				
	TE 364-3					156	131		
	TE 616							90	75
3412B	PKM								
	NM1	260	215						
	NM1 O/L			230	195				
	NM2					190	165		
	NM2 O/L							180	155
3412H	ACS	361	316	361	316	361	316	361	316
3413	Avionics	1140	995	1140	995	1140	995	1140	995
3414	Structure	308	270	308	270	308	270	250	220

Table 3-44. SSUS Two-Stage, Complete Avionics, Satellite-Independent Unit Costs (Continued)

RATE/YR	EO-09A		EO-07A		AS-05A		EO-57A		
	6	12	6	12	6	12	6	12	
3046	GSE Maintenance	10	4	10	4	10	4	10	4
3060	Sys. Proj. Mgmt.	100	88	100	88	100	88	100	88
3090	Flight Support	180	158	180	158	180	158	180	158
9950	Transportation	10	10	10	10	10	10	10	10

COST FY 76 \$ x 1000 NO FEE

Table 3-45. SSUS Single-Stage, PKM Only, Minimum Avionics,
Satellite-Dependent Unit Costs

	RATE/YR	EO-09A		EO-07A		AS-05A		EO-57A	
		6	12	6	12	6	12	6	12
3000	SSUS	680	580	650	560	610	530	562	486
3110	I&A	33	29	33	29	33	29	33	29
3412A	AKM	NONE							
3412B	PKM								
	NM1	260	215						
	NM1 O/L			230	195				
	NM2					190	165		
	NM2 O/L							180	155
3412H	ACS	NONE							
3413	Avionics	35	31	35	31	35	31	35	31
3414	Structure	188	165	188	165	188	165	150	131
3046	GSE Maintenance	8	3	8	3	8	3	8	3
3060	Sys. Proj. Mgmt.	50	44	50	44	50	44	50	44

Table 3-45. SSUS Single-Stage, PKM Only, Minimum Avionics,
Satellite-Dependent Unit Costs (Continued)

	RATE/YR	EO-09A		EO-07A		AS-05A		EO-57A	
		6	12	6	12	6	12	6	12
3090	Flight Support	98	85	98	85	98	85	98	85
9950	Transportation	8	8	8	8	8	8	8	8

COST FY 76 \$ x 1000 NO FEE

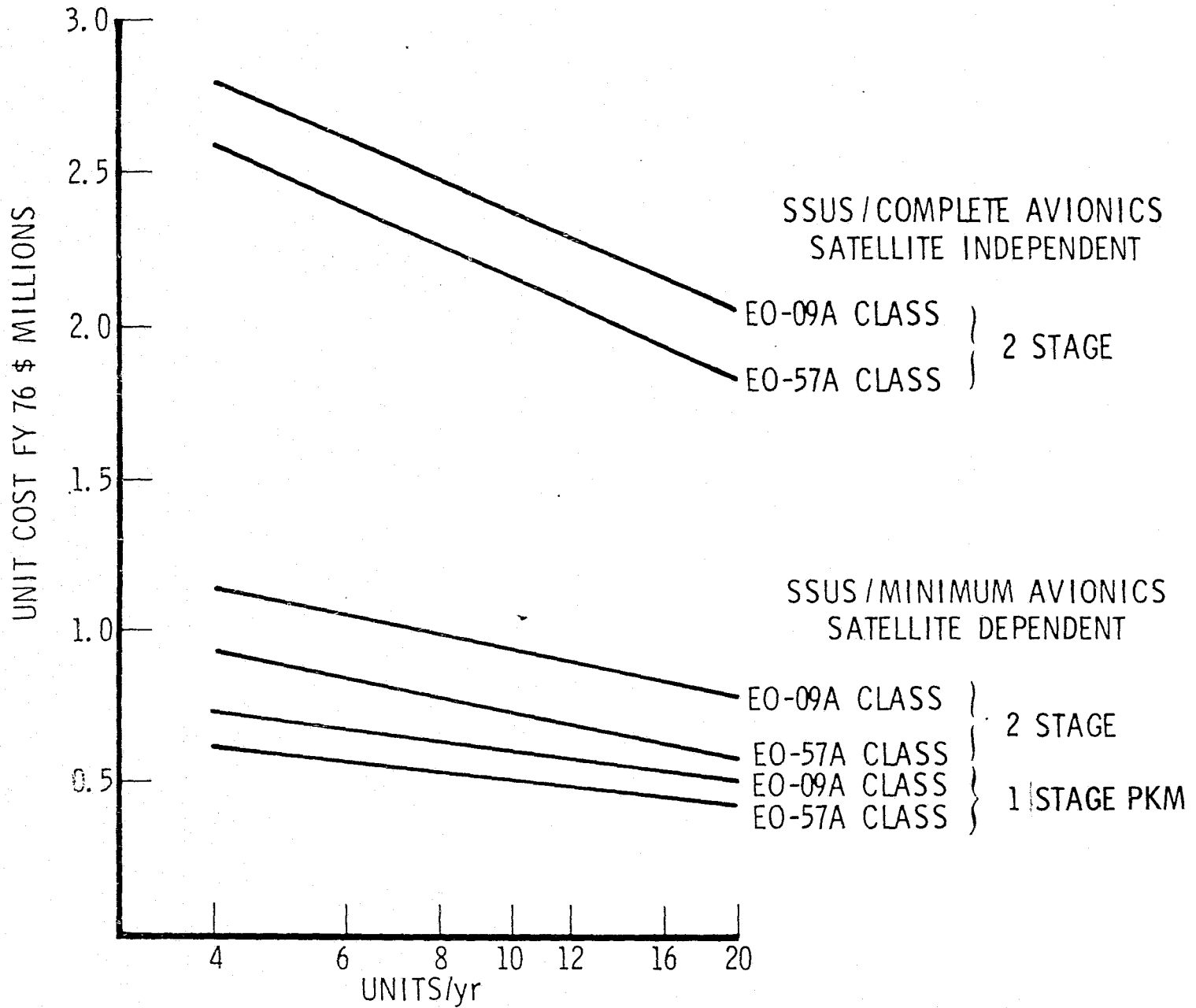

Figure 3-38. SSUS Unit Costs

SECTION 4

SUBTASK IV: OPERATIONS ANALYSIS

4.1

GENERAL

Subtask IV was the smallest task area of Study 2.6 involving SSUS conceptual flight/ground operations and general characteristics in comparison to the IUS, Tug, and STS system. Operations analysis of the IBM and Martin Marietta Corp. /IUS/Tug studies were contrasted with conceptual SSUS operations. SSUS basic operations concepts as a satellite-dependent and satellite operations control center ground-commanded system differ sharply from the relatively autonomous IUS/Tug concepts. Ground operations are characterized by simplicity and a single major SSUS spin balance, alignment, and assembly facility at the launch site. The spin facility dynamically balances the individual motors and satellites, performs a precise CG alignment and assembly/checkout for each SSUS stack, and installs the SSUS in the deployment cradle and/or spin table. It may be desirable to not only balance the individual masses of satellites and motors but also to spin check the entire assembly. From this facility, it would be transported to the payload changeout room (PCR) like any other upper stage. The SSUS considered as an addition to the IUS or Tug has no significant impact on the IBM IUS/Tug Orbital Operations and Mission Support Study. The SSUS impacts are primarily in the Orbiter Interface and Flight Operations, the Ground Tracking Network, and the Spacecraft Operations Control Center.

SSUS timelines for the geosynchronous option are relatively long when compared to the IUS due to the revolutions in the transfer orbit for ground tracking prior to AKM burn. Tug time lines are comparable if phasing-orbit ascent profiles are used. The SSUS orbit accuracy is comparable to present Delta 2914 ELVs and has errors approximately 2-1/2 times as great as the IUS/Tug systems. SSUS satellite support is negligible

compared to the IUS or Tug; in fact, essentially the SSUS is supported by the payloads with power, command, and control. More specific discussions of these areas are presented in the following pages.

4.2 COMPARISON OF SSUS, IUS, AND TUG UPPER STAGE SYSTEMS

A brief comparison of the STS upper stage options to the extent that SSUS data and concept details are available was made. These stages cover a broad range of concept, applicability, and options.

Basically, these stages have the following general categorization:

- | | | |
|----|------|--|
| a. | SSUS | Spin stabilized, expendable, solid rocket motor, Orbiter and ground commanded, satellite dependent |
| b. | IUS | Three-axis stabilized, inertial guidance, expendable or reusable, liquid or solid rocket motor |
| c. | Tug | Three-axis stabilized, inertial guidance, fully reusable, liquid rocket motor |

The IUS and Tug are autonomous systems having standard interfaces capable of accepting the entire range of satellites in the mission model. The SSUS system is completely non-autonomous and dependent on external systems such as the Orbiter, the satellite, and a ground tracking network. The SSUS may have standard interfaces for a wide range of satellites in the mission model, but it is more likely to be tailored to the requirements of certain portions of the mission model and specifically, perhaps, to spin-stabilized satellites. The payload capability of the system is related to the mission model, but for the geosynchronous orbit, the data are as follows:

- | | | | |
|----|------|-----------------------------------|-------------------------------|
| a. | SSUS | 1474 to 3311 kg (3250 to 7300 lb) | expendable |
| b. | IUS | 5443 kg | (up to 12,000 lb) expendable |
| c. | Tug | 5443 kg | (12,000 lb) expendable |
| d. | Tug | 3595 kg | (7926 lb) deploy only |
| e. | Tug | 1540 kg | (3396 lb) retrieve only |
| f. | Tug | 939 kg | (2070 lb) deploy and retrieve |

The capability of the Tug to retrieve as well as deploy or do both functions in a single mission is, of course, unique.

The orbital accuracy comparisons between the SSUS and IUS/Tug systems are compared in detail in the accuracy section of this report. In summary, the SSUS requires about three times the delta velocity capability in the satellite for orbit error corrections compared to an IUS or Tug. The SSUS accuracy is generally comparable in magnitude to that of the present Delta 2914 expendable launch vehicle.

The Tug and IUS are capable of multiple satellite missions on a single stage. However, the SSUS, due to the spin stabilization, requires the payload CGs to be aligned on the spin axis through the SSUS CG, thus multiple payloads are unlikely on the SSUS except as a pancake stack. The IUS and Tug can carry combinations of spacecraft mounted off the center line of the stage in a dispensing mechanism. An example in this study was the AS-05A satellite which is Tug launched in a dual side-by-side configuration from a single Tug. With the SSUS, it is necessary to utilize an SSUS stage system for each of the two AS-05A satellites. Multiple payloads with the SSUS are more feasible when two SSUS systems are mounted in tandem or in a 2×2 configuration of smaller SSUSs in the Orbiter bay.

The SSUS system's stability and accuracy is influenced by the mass properties of the payload, and the solid rocket motor loading or velocity vectors are determined by the payload weight and orbit. The SSUS hardware details and mission analysis tasks are thus highly individualized and program peculiar for each payload. In contrast, the IUS and Tug are relatively insensitive to the payload mass properties and orbit, although dynamic stability, control, and mission orbit analyses are required. The liquid rocket stages have considerable flexibility in multiple burn missions, while the SSUS solid rocket motors are restricted to discrete burns and numbers of solid stages. The Tug and IUS systems are considerably more flexible in mission application than the SSUS.

The SSUS system is a very simple device having few of the complexities of the IUS/Tug systems. No liquid propellant or gaseous fluid transfer systems are involved, and avionics are minimal. These simplifications are offset by the satellite interface being active in the command and control of the SSUS with both the Orbiter and the ground station tracking network. The mechanical and electrical simplicity of the SSUS extends to the cradle spin-table system. The principal complexity is the spin table, but this appears to be a relatively straightforward electric-motor-driven system with a minimum of electrical interface through a slip-ring assembly. The SSUS cradle might even be an IUS or Tug cradle with adapters to carry the launch loads and mount the spin table on the aft end for SSUS missions.

Due to the absence of fluid interfaces and the minimal electrical interfaces, the SSUS system should be considerably easier to install and remove from the Orbiter than either the IUS or Tug systems. In general, ground handling operations are reduced.

Ground operations for the SSUS consist of receiving and inspection of the solid rocket motors, stage structures, and associated components. The solid rocket motors are stored in the solid rocket motor storage until required. SSUS assembly and limited checkout occurs in a spin-balance facility. The SSUS spin-balance facility is necessarily larger than the present ETR Delta balancing facility. The facility is approximately 90 × 60 m (300 × 200 ft) and of high-bay construction. Normal factory air conditioning and cleanliness standards are sufficient. The major piece of equipment in the facility is a vertical dynamic balancing machine with a capability of 13,000 to 30,000 kg (30,000 to 65,000 lb) at speeds up to 110 rpm. An overhead traveling crane is required for SSUS assembly and handling. The SSUS solid rocket motors are spin balanced along with the SSUS structural sections. Similarly, the satellites are brought to the facility from their checkout area and spin balanced before mating to the SSUS. The satellite and SSUS are aligned, assembled, further check balanced as required, and then installed on the spin tables (previously balanced and reuseable) and cradle. The cradle

with payload and SSUS is then prepared for transport to the PCR for installation in the Orbiter. Ground equipment consists primarily of handling fixtures and trailer dollies.

SSUS time lines associated with these ground operations are compatible with the work hours schedule established for Orbiter ground processing (Figure 4-1). Considerably more time margin is available over Tug/IUS systems due to the SSUS simplicity.

The safety aspects of the SSUS appear to be comparable to the IUS/Tug. The hazards introduced by the spin table and spin-stage satellite combination appear to be such that careful design will minimize the possibilities of an accident. The absence of liquid and gaseous systems and connections and the simplicity of the avionics and operations probably mitigate the overall safety problem of the SSUS considerably. Other hazards are those common to the presence of safe-and-arm systems, motor igniters, and electro-explosive devices. The solid propellant motors are Class II propellant and, while not readily jettisonable, should not present a hazard in an abort situation. They would probably be below the 14, 515-kg (32, 000-lb) Orbiter landing payload weight for most geosynchronous missions.

4.3 COMPARISON OF SSUS, IUS, AND TUG MISSION TIME LINES

The preliminary definition of the SSUS makes the SSUS time line subject to considerable refinement and change. Table 4-1 presents time line data for a SSUS geosynchronous mission. This mission uses apogee injection on the fourth geosynchronous apogee as a nominal case. Actually, injection can be made at earlier or later apogees, depending on mission requirements and ground tracking network capabilities. Tables 4-2 and 4-3 offer similar time-line data for the Tug and IUS. These are abbreviated data, but they are useful for preliminary comparisons with the SSUS concept.

Total mission duration through satellite injection with the SSUS is about 45 hr but could be between 13.7 and 120 hr to injection. In this study, injection was considered between the first and eleventh apogees (FleetSatCom

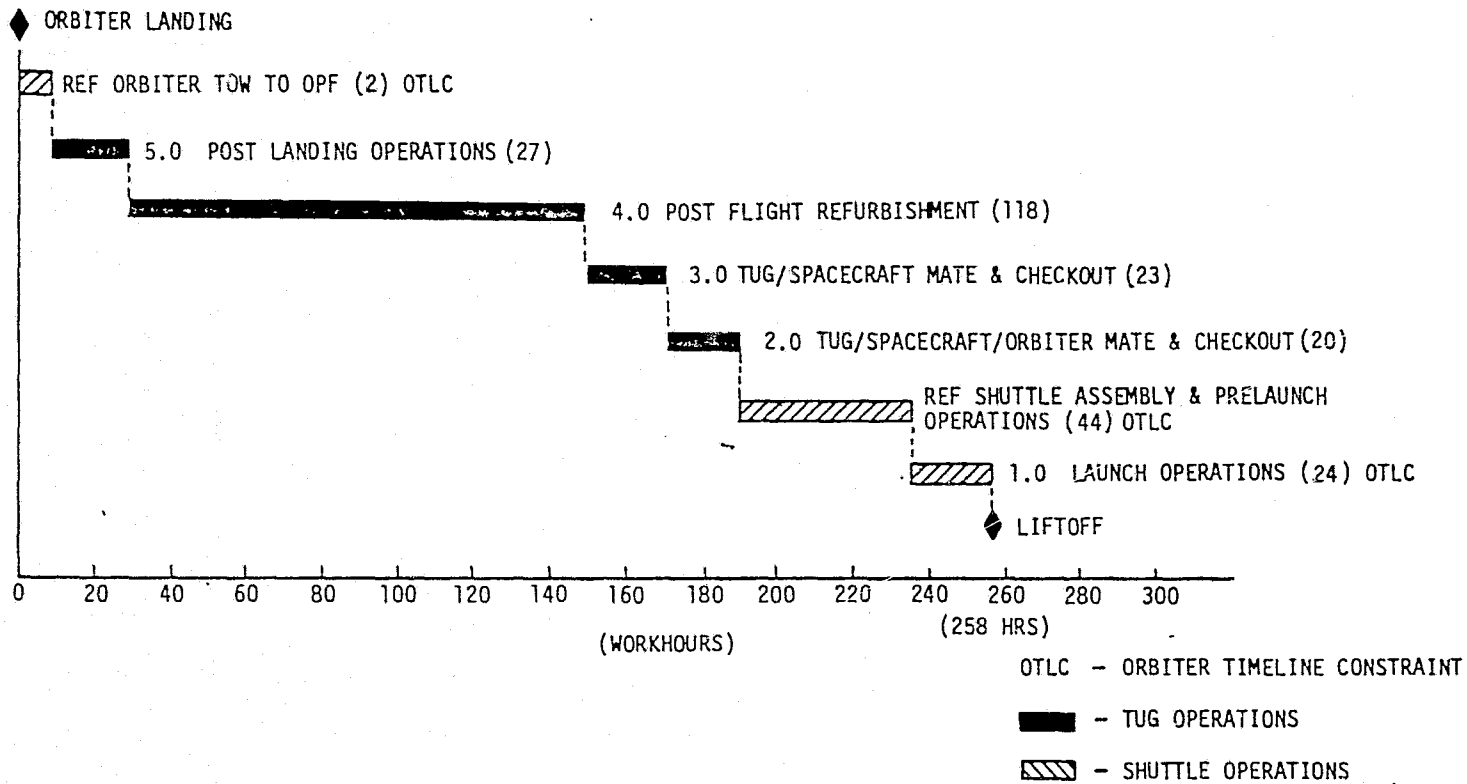

Figure 4-1. Estimated Baseline Tug Ground Processing Time Line

ORIGINAL PAGE IS
OF POOR QUALITY

Table 4-1. SSUS Mission Time Line for Satellite Delivery

<u>Event No.</u>	<u>Event</u>	<u>Duration of Event (hrs)</u>	<u>Total Time (hrs)</u>
1	Shuttle Liftoff	0	0.00
2	Circularize into 296, 32 Km (160 nm) Orbit	3.06	3.06
3	On-orbit checkout of Satellite	1.0	4.06
4	SSUS, Cradle and Spin Table Checkout	0.25	4.31
5	Align Orbiter Inertial Attitude Reference	0.25	4.56
6	Orient Orbiter to SSUS PKM Velocity Vector	0.20	4.76
7	Erect SSUS Spin Table	0.10	4.86
8	Spin Table Star Sensor Acquisition and Orbiter Interlock with Star Sensor	0.10	4.96
9	SSUS Orbiter Interface Hardware Transfer to Satellite RF Link	0.1	5.06
10.	Spin Table Spin Up	0.15	5.21
11.	Arm Separation and Command SSUS Separation	0	5.21
12.	Retro Orbiter to 914 meters (3000 ft) Safe Distance and Brake Spin Table to Zero speed, Enable SSUS Active Nutation Control	0.10	5.31
13.	Rotate Spin Table back to Cradle and Secure	0.10	5.41
14.	SSUS Coast to selected nodal crossing	0-3.0	8.41
15.	Orbiter issue Arm and Fire Command to SSUS for PKM burn - using Satellite RF Link at Time of Selected Nodal Crossing	0	8.41
16.	SSUS PKM Burn and PKM Separation	0.04	8.45
17.	SSUS 296. 32 x 35, 786 Km (160 x 19, 323 nm) 10.5 hr period Transfer Orbit, Satellite and SSUS under ground station network RF command. Coast to 1st Apogee.	5.25	13.70
18.	SSUS 2nd Apogee Ground Command Coarse Attitude Correction, AKM Velocity Vector pointing	10.5	24.20
19.	SSUS 3rd Apogee Ground Command Fine Attitude Correction, AKM Velocity Vector Pointing	10.5	34.70
20.	SSUS 4th Apogee Ground Command Arm and Fire SSUS AKM to Circularize 35, 786 Km (19, 323 nm) Orbit	10.5 + 0.03	45.20
21.	Jettison AKM and Begin Satellite Orientation and Deployment	0.25	45.45
22.	Orbital Trim Maneuvers	--- Extended Period ---	

Table 4-2. Tug Mission Time Line for Satellite Delivery

<u>Event No.</u>	<u>Event</u>	<u>Duration of Event (hr)</u>	<u>Total Time (hr)</u>
1	Shuttle Liftoff	0	.00
2	Circularize into 296.32 km (160 nmi) orbit	3.06	3.06
3	Checkout and Deploy Tug	2.0	5.06
4	Separate to Safe Distance	.0	5.06
5	Phase in Shuttle Orbit	.0-11.0	16.06
6	Phasing/Plane Change Burn	0-.17	16.23
7	Coast One Rev. in Phasing Orbit	1.5	20.84
10	Midcourse Correction	.03	20.87
11	Coast to 35,786 km (19,323 nmi)	3.46	24.33
12	Apogee Burn	.13	24.46
13	Coast and Orbit Trim	12.0	36.46
14	Deploy Payload	1.0	37.46
15	Phase in Orbit for Nodal Crossing	10.4	47.86
16	Deboost Burn 314.84 km (170 nmi) Perigee Transfer Orbit	.07	47.93
17	Coast	1	48.93
18	Midcourse Correction	.01	48.94
19	Coast to 314.84 km (170 nmi) Perigee	4.2	53.14
20	Inject into Return Phasing Orbit	.04-.08	53.18
21	Coast 1 Rev. in Phasing Orbit	.0-3.0	56.18
22	Circularize into 314.84 km (170 nmi) Orbit	0-.04	56.22
23	Orbit Trim	0.	56.22
24	Tug and Shuttle Phasing Terminal Rendezvous and Docking	4.0	60.22

Table 4-3. Expendable IUS Mission Time Line for Satellite Delivery

<u>Event No.</u>	<u>Event</u>	<u>Duration of Event (hr)</u>	<u>Total Time (hr)</u>
1	Shuttle Liftoff	0	0.0
2	Circularize into 296.32 km (160 nmi) Orbit	3.06	3.06
3	Checkout and Deploy IUS	2.0	5.06
4	Separate to Safe Distance	0	5.06
5	Coast to selected nodal crossing	0 to 3.0	8.06
6	IUS Perigee Burn into 296.32 × 35,786 km (160 × 19,323 nmi) Transfer Orbit	0	8.06
7	Coast in Transfer Orbit to First Apogee	5.25	13.31
8	Apogee Burn to Circularize 35,786 km (19,323 nmi) Orbit	0	13.31
9	Satellite Orientation and Separation by IUS	0.1	13.41

can inject as late as the eleventh apogee). The SSUS, as with current AKM-system satellites on ELVs, injects the satellite into a drift orbit with a 15 to 30 m/sec (50-100 ft/sec) velocity deficiency for final positioning. The Tug and IUS can inject as early as the first apogee at a nominal 13.7 hr into a drift orbit also. The Tug time line data in Table 4-2 show a 37.45-hr time of injection due to use of an intermediate phasing orbit to arrive at a selected apogee longitude of injection.

The SSUS geosynchronous payload study indicated that for the satellites studied and the mission modes employed, no constraints were present on time from Orbiter deployment to injection by the SSUS. Electric power requirements could be met by providing for the satellite solar arrays to have panels facing outward in the stowed position, thus producing partial power sufficient for the partially-powered-up satellite requirements during

the assumed coast to the fourth apogee. Thermal analysis indicated the spin environment presented no constraints, so that the preliminary study showed no immediate limitation on satellite transfer orbit coast time capability. In an option where the SSUS has its own autonomous avionics, principally TT&C, as well as its own ACS and active nutation control, a trade-off limitation would exist due to the use of silver zinc batteries for SSUS power rather than payload solar arrays.

As the foregoing implies, the spacecraft receives no support from the baseline SSUS; rather, the SSUS is supported by the spacecraft. The IUS support to the satellite can include electric power (requires batteries on the IUS), thermal maneuvers, and final attitude positioning options of considerable latitude. The baseline Tug can supply 600 Watts of power as well as provide thermal maneuvers and final injection positioning of even greater flexibility than the generic IUS. The autonomous avionics, ACS option of the SSUS would place no demands upon the satellite subsystem, other than the fundamental capability to withstand spin, but would provide no support other than perhaps extra battery power.

4.4 COMPARISON OF SSUS, IUS, AND TUG FLIGHT OPERATION

4.4.1 Introduction

Reference 1 was reviewed to determine the impact of the SSUS on the flight operations envisioned for the IUS/Tug. The major conclusions from this review are tabulated below (Table 4-4). Supporting information for these conclusions is contained in the succeeding pages.

4.4.2 IUS/Tug Operations Study Documents Reviewed

Reference 1: NASA Contract No. NAS 8-31009, IBM Final Report No. 75W-0072, dated May 1975, "IUS/Tug Orbital Operations and Mission Support Study."

Reference 2: NASA Contract No. NAS 8-31011, Martin-Marietta Final Report No. MCR-74-488, dated February 1975, "Tug Fleet and Ground Operations Schedules and Controls."

Table 4-4. Major Conclusions of Flight Operations Review

1. THE SSUS HAS NO SIGNIFICANT IMPACT ON THE CONCLUSIONS IN REFERENCE 1
2. IUS/TUG FLIGHT OPERATIONS CONTROL CENTER NOT USED FOR SSUS
(Orbiter, Spacecraft Operations Control Center, and spacecraft are used to monitor, command, and control spacecraft/SSUS combination.)
3. SSUS HAS NO AUTONOMY
(Relies on command and control by ground, Orbiter, and spacecraft.)
4. SSUS REQUIREMENTS SHOULD BE CONSIDERED EARLY IN THE PLANNING OF FLIGHT OPERATIONS FOR ORBITER, NETWORK, AND SPACECRAFT OPERATIONS CONTROL CENTER
5. ORBITER ACCOMMODATIONS ARE ADEQUATE TO SUPPORT SSUS
(No need for (1) navigation information; (2) propellant dump, vents, and purges; or (3) remote manipulator operations. Add control of (1) pointing, (2) spinup, and (3) separation.)
6. SSUS INCREASES SOFTWARE AND MANPOWER COSTS FOR THE SPACECRAFT OPERATIONS CONTROL CENTER
7. SSUS INCREASES SPACECRAFT'S SUPPORT REQUIREMENTS
(Relies on spacecraft systems--telemetry, communications, command and control, pointing.)
8. EXISTING GROUND/FLIGHT SOFTWARE FOR SPINNING SPACECRAFT/KICK MOTOR COMBINATIONS ADAPTABLE FOR SSUS

4.4.3 Review of Reference 1

4.4.3.1 Impact of SSUS on Reference 1 Conclusions

The conclusions of Reference 1 are summarized in Table 4-5.

Table 4-5. Conclusions from Reference 1

1. OPERATIONAL CONCEPT 1 (SEPARATE NASA AND DOD FACILITIES) IS RECOMMENDED FOR THE CASES STUDIED
 - KEPNER-TREGOE RESULTS
 - DOD HAS SECURITY RESTRICTIONS ON IUS/TUG
 - POTENTIAL NON-USA PAYLOADS ON IUS/TUG
 2. SPACE TUG (LEVEL II) AND EIUS (LEVEL B) ARE RECOMMENDED
 - TECHNOLOGICAL TRENDS MAKES HIGH AUTONOMY FEASIBLE
 - GROUND SOFTWARE/MANPOWER COSTS ARE REDUCED
 3. ORBITER ACCOMMODATIONS ARE ADEQUATE FOR IUS/TUG OPERATIONAL INTERFACE REQUIREMENTS
 4. IUS AND SPACE TUG SHOULD BE CONSIDERED A SINGLE OPERATIONAL PROGRAM
 - DEVELOPMENT SHOULD BEGIN JANUARY 1977
 - SOFTWARE DEVELOPMENT LAB IS REQUIRED TO ENABLE PARALLEL DEVELOPMENT
 - PROVIDES REDUCTION IN OVERALL DDT&E (\approx \$14M)*
 5. OPERATIONAL COST DRIVERS
 - GROUND SOFTWARE (DDT&E)
 - MANPOWER (RECURRING)
 6. FLIGHT SOFTWARE AND GROUND SOFTWARE SHOULD BE APPROACHED AS ONE TECHNICAL PROBLEM
- *Reference 1 text supports \$30M savings

These conclusions are amplified below, and comments are provided on the impact of the SSUS on the conclusions. DDT&E cost information is worst case, since it is based on no utilization of existing facilities, data systems, and software.

4.4.3.1.1 Conclusion 1: Separate NASA and DoD IUS Flight Operations Control Centers (Operational Concept 1) is Recommended, Although It Is The Most Costly

This recommendation is based on:

- a. Results of decision analysis
- b. Simplified operations and provision of the greatest flexibility within each agency
- c. DoD security restrictions on IUS/Tug

It is noted that under any operational concept considered in Reference 1, flight operations facilities other than the IUS/Tug control centers are treated as separate for NASA and DoD.

The costs for separate IUS/Tug control centers is \approx \$13 million more for DDT&E and \approx \$1 million less recurring per flight compared to costs for a combined IUS/Tug control center.

Impact of SSUS on Conclusion 1: The SSUS does not require use of an IUS/Tug Flight Operations Control Center. The Orbiter, Orbiter Control Center, and the Spacecraft Control Center will control the SSUS. Thus the SSUS has no impact on Conclusion 1.

4.4.3.1.2 Conclusion 2: Expendable IUS (EIUS) Level B Autonomy and Tug Level II Autonomy are Recommended

EIUS Level A Autonomy is summarized as follows:

- a. Tone Command System (limited to only two on/off commands)
- b. No operational interface with the onboard computer
- c. No navigational or target-update capability

EIUS Level B Autonomy is summarized as follows:

- a. Digital Command System
- b. Operational interface with the onboard computer
- c. Navigation or target-update capabilities

Level B reflects increased ground involvement with more ground software and more ground manpower than Level A. It approximates current capabilities of the vehicles being studied by DoD. Costs for Level B are \approx \$8 million more for DT&E and \approx \$2 million more recurring per launch than costs for Level A.

The Level B version of the EIUS (Reusable IUS was not studied because it approximates the Tug case) was chosen because: (1) Level A was unable to meet NASA placement accuracy constraints within the performance envelope, and (2) Level A had a command system with no capability for real-time alternate mission completion or time line adjustment other than to terminate the mission.

Tug Level II Autonomy is summarized as follows:

- a. MSFC Baseline Tug
- b. Autonomous navigation utilizing Interferometric Landmark Tracker (ILT)
- c. Rendezvous and docking closed loop through on-board sensors

Tug Level III Autonomy is summarized as follows:

- a. MSFC Baseline Tug
- b. Ground tracking required, no autonomous navigation
- c. Rendezvous and docking uses man-in-the-loop TV

Level II reflects decreased involvement of ground software and ground manpower and increased flight hardware and software compared to Level III. Technological trends make high autonomy feasible. High autonomy reduces costs for ground software and ground manpower but increases costs for flight hardware and software. Costs for Level II are \approx \$7 million less for DDT&E and \approx \$1 million less recurring per launch than costs for Level III.

The total costs in \$ millions for the recommended EIUS and Tug systems are as follows:

	<u>DDT&E</u>	<u>Recurring[*] (per launch)</u>
a. EIUS, Concept 1, Level B	50.0 (25.0 each, DoD & NASA)	5.5
b. Tug, Concept 1, Level II	51.0 (25.5 each, Dod & NASA)	5.8
c. EIUS/Tug Unified Operational Program (see Conclusion 4, below)	70.0 (35.0 each, DoD & NASA)	

^{*}Does not include cost of flight hardware

Impact of SSUS on Conclusion 2: The SSUS will have no autonomy. It will be controlled by Orbiter command and/or ground command. Spacecraft hardware should be utilized to (1) provide pointing control of the spacecraft/SSUS combination, and (2) relay event commands to the SSUS. Thus, the SSUS has no impact on Conclusion 2.

4.4.3.1.3 Conclusion 3: Orbiter Accommodations, Described in JSC 07700, Vol XIV, Change 7, are Adequate for IUS/Tug Operational Interface Requirements

SSUS Impact on Conclusion 3: Less accommodations are required for SSUS than for IUS or Tug:

- a. Simple caution and warning
- b. No propellant dump
- c. Simple deployment, no manipulator arm
- d. Signal interface through spacecraft only.

The Orbiter must support pointing and give commands for spinup, separation, and PKM firing.

4.4.3.1.4 Conclusion 4: IUS and Tug Should Be Approached
As a Single Operational Problem

This is stated to be the strongest conclusion of the Reference 1 study. DDT&E costs should be ~ \$30 million less (\$15 million for DoD and \$15 million for NASA) and orderly operations developments should result. Development should begin in January 1977. (Note that Table 4-5 only shows \$14 million savings. Details in the text of Reference 1 supports \$30 million savings.)

Control center software is the major DDT&E cost. A Software Development Lab is required to enable parallel development.

Impact of SSUS on Conclusion 4: The SSUS has no impact on Conclusion 4. It does not make use of the IUS/Tug Operational Control Center or the IUS/Tug ground and flight software.

If the SSUS is to be developed, it should be considered early in the planning for other elements of flight operations (Orbiter, network, Shuttle/Orbiter Control Center, Spacecraft Operations Control Center, and spacecraft).

4.4.3.1.5 Conclusion 5: The Operational Cost Driver for DDT&E
Is Ground Software and for Recurring Is Manpower

Ground software accounted for \approx 50 percent of DDT&E costs. Significant savings can be achieved by developing a unified IUS/Tug operational program (see Conclusion 4). Additional major savings would result from utilizing existing software rather than developing totally new packages.

Flight control and flight support manpower accounted for \approx 55 percent of recurring costs per annum. Additional studies are needed to determine techniques to reduce manpower requirements.

High IUS/Tug autonomy reduces both of these costs items (see Conclusion 2).

Impact of SSUS on Conclusion 5: The SSUS has no impact on Conclusion 5. However, it will increase ground software and manpower costs for the Spacecraft Operations Control Center. Existing ground and flight software is adaptable for SSUS.

4.4.3.1.6 Conclusion 6: Flight Software And Ground Software
Should Be Approached As One Technical Problem

In allocating operational functions between the ground and on-board systems, both sets of software need to be evaluated together to minimize complexity, effort, and cost.

Impact of SSUS on Conclusion 6: The SSUS operation is not covered by software for the EIUS/Tug, so there is no impact on Conclusion 6 due to the SSUS.

The SSUS is controlled by ground and flight software for the spacecraft. The software required for SSUS operation is much less complex than that for the EIUS/Tug, but it also should be developed as one technical problem.

4.4.3.2 Applicability of EIUS Operations Information for SSUS

EIUS operations information in Reference 1 is summarized in tables which follow. The applicability for SSUS was determined, and comments are given for each table. This approach is used to ease and expedite understanding of the similarities and differences between EIUS and SSUS and to build on the base of a previous, extensive study.

4.4.3.2.1 SSUS/Orbiter Operational Interactions

All of the operational interactions given in Table 4-6 between the EIUS and Orbiter apply to the SSUS/Orbiter.

4.4.3.2.2 SSUS Checkout Analysis Ground Rules and Assumptions

Except as noted by comments in parentheses for Items 2 and 3 in Table 4-7, the ground rules and assumptions for analysis of EIUS checkout apply to SSUS. Item 3, SSUS dependent versus EIUS autonomous, is a very big difference. Thus, SSUS has very little equipment to be checked out compared to EIUS.

Table 4-6. EIU/Orbiter Operational Interactions

1. SAFETY MONITORING AND CONTROL
 - a. EIU C&W/BU C&W (PRESSURES, TEMPERATURES, BUS SAFES, BUS POWER)
 - b. ORBITER SWITCHES TO CORRECT C&W CONDITIONS
2. EIU ACTIVATION AND DEPLOY MONITORING AND CONTROLS
 - a. ORBITER SWITCHES TO ACCOMPLISH ACTIVATION AND DEPLOYMENT
 - b. FEEDBACKS TO LIGHTS INDICATE TASKS ACCOMPLISHED
3. EIU STATUS MONITORING AND COMMANDING (LARGELY FED THRU ORBITER TO/FROM GROUND CONTROL)
 - a. DETAILED EIU STATUS (C/O) PRIME RESPONSIBILITY OF GROUND
 - b. CONTINGENCY COMMANDING POSSIBLE FROM GROUND

Table 4-7. EIOUS Checkout Analysis Ground Rules and Assumptions

1. EXPENDABLE IUS
2. ~~SLIGHTLY MODIFIED EXISTING VEHICLE IS BASELINE~~
(SSUS is a new vehicle family utilizing existing technology)
3. ~~BASICALLY AUTONOMOUS WITH~~ COMMAND CAPABILITY
(SSUS is completely dependent on Orbiter, ground, and spacecraft for control and command)
4. LIMITED SELF-TEST AND LIMITED REDUNDANCY MANAGEMENT
5. OPERATIONAL IN VICINITY OF MAN (ORBITAL)
6. ANALYSIS INCLUDES ON-ORBIT OPERATIONS PRIOR TO INITIAL IUS BURN

4.4.3.2.3 SSUS On-Orbit Checkout Philosophy

The on-orbit checkout philosophy for the SSUS is very similar to that given in Table 4-8 for the EIUS. Comments on differences are contained in parentheses. The SSUS depends on the Spacecraft for (1) pointing control, (2) commands, and (3) relay of SSUS operational data to the Orbiter and the Spacecraft Control Center. Ground involvement is by the Spacecraft Control Center, not the IUS/Tug Operations Control Center.

4.4.3.2.4 SSUS Checkout Requirement Summary

The IUS checkout requirements are summarized in Table 4-9. Since the SSUS is a much simpler stage than the EIUS, the checkout requirements are less. Requirements that are not applicable to the SSUS are identified by the comments added and enclosed in parentheses.

4.4.3.2.5 SSUS Major Component Checkout/Monitoring Summary

Table 4-10 gives the major components for the EIUS and indicates the requirements for monitoring the proper operation of these components. Items that do not apply for SSUS are crossed out. Similar-type components are expected to be on the spacecraft, regardless of whether the spacecraft is on an EIUS or SSUS. They would be used to support the SSUS/spacecraft combination as necessary. Their monitoring and checkout requirements, however, are chargeable to spacecraft support, not SSUS support.

Additional components for SSUS are shown in parentheses. These additional SSUS components are for spinup and separation

4.4.3.2.6 Orbiter Software Functions to Support the SSUS

The Orbiter software functions to support EIUS are listed in Table 4-11. The items that are not required for SSUS are crossed out, and the additions for SSUS are given in parentheses.

Table 4-8. EIOUS On-Orbit Checkout Philosophy

1. UTILIZE EIOUS STATUS, ACTIVATION, AND OPERATIONAL DATA FROM EIOUS SUBSYSTEM STATUS
(Subsystem data from SSUS is anticipated to go to the spacecraft for forwarding by (1) hardwire to Orbiter or by (2) spacecraft telemetry to Orbiter and ground)
2. MINIMIZE MISSION TIME PRIOR TO DEPLOYMENT AND EIOUS FIRST BURN
3. ACTIVATE SUBSYSTEMS/COMPONENTS ONLY WHEN REQUIRED FOR OPERATION
4. LIMIT EIOUS CHECKOUT TO MISSION CRITICAL SUBSYSTEMS ACTIVATED AFTER DEPLOYMENT
5. ~~NO PREPLANNED COMMAND ACTIVITY ALLOCATED TO GROUND~~
(SSUS/spacecraft pointing and SSUS AKM burn are both commanded by ground)
6. NO ORBITER CHECKOUT INVOLVEMENT AFTER DEPLOYMENT
7. GROUND INVOLVEMENT
 - a. MONITORS STATUS, ACTIVATION, CHECKOUT AND OPERATIONAL DATA
 - b. PROVIDES COMMANDS OR INHIBITS IF ONBOARD EIOUS MALFUNCTIONS OCCUR

(Ground involvement is by the Spacecraft Control Center, not the IUS/TUG Control Center)
8. ORBITER INVOLVEMENT
 - a. MONITORS C&W SAFETY AND CRITICAL SUBSYSTEM PARAMETERS
 - b. CONTROLS DEPLOYMENT OPERATIONS
 - c. INITIATES SOME ACTIVATION AND BACKUP SEQUENCE INITIATION COMMANDS
9. ~~EIOUS COMMANDS ALL NON-C&W/ABORT EIOUS SEQUENCING/FUNCTIONS~~
(The Orbiter/Spacecraft Control Center/Spacecraft command the SSUS operations)

Table 4-9. EIOUS Checkout Requirements Summary
(Ref: SR-IUS-100, July 1974)

1. PROVIDE DATA TO ORBITER CONCERNING STATUS, OR CONDITION, OF SAFETY CRITICAL PARAMETERS. PROVISIONS SHALL BE MADE FOR ORBITER CONTROL OF THESE FUNCTIONS
2. THE IUS SYSTEM SHALL VERIFY THE ABILITY OF THE IUS TO PERFORM ITS MISSION, AFTER ORBITER ASCENT BUT PRIOR TO DEPLOYMENT
3. THE IUS EXTERNAL COMMANDS CAPABILITY SHALL PROVIDE THE NECESSARY SAFETY AND EXECUTIVE CONTROLS OF THE IUS
4. PROVIDE DATA DURING DEPLOYMENT, AND WHILE IN THE NEAR VICINITY OF THE ORBITER, THAT PERMITS THE EVALUATION OF THE STATUS, OR CONDITION, OF SAFETY CRITICAL FUNCTIONS
5. PROVIDE, WHILE IN THE PAYLOAD BAY, ADEQUATE DATA TO ESTABLISH THE SAFETY STATUS OF THE IUS/SPACECRAFT
6. COMMUNICATE STATUS AND RECEIVE COMMANDS REQUIRED FOR STATUS MONITOR AND CHECKOUT FROM ORBITER WHILE IN THE PAYLOAD BAY
7. ORBITER NAVIGATION DATA MAY BE USED BY THE IUS. CONTROL OF MECHANICAL ALIGNMENTS AND OPTICAL PLATFORM ALIGNMENT TECHNIQUES WILL NOT BE PROVIDED. SELECTED UPDATE MEANS FOR ATTITUDE, POSITION AND VELOCITY SHALL NOT RESULT IN NASA/DOD PECULIAR GUIDANCE SYSTEM MECHANIZATIONS

(SSUS does not have a requirement for orbiter navigation data)

Table 4-9. EIUS Checkout Requirements Summary
(Ref: SR-IUS-100, July 1974) (Continued)

8. ACCOMMODATE THE TRANSMISSION OF SPACECRAFT TELEMETRY AND SAFETY DATA TO THE ORBITER WHILE ATTACHED TO THE ORBITER

(This may be via hardwire across the SSUS or via umbilical between the spacecraft the the orbiter)
9. CAPABLE OF TRANSMITTING TO THE GROUND:
 - STATE VECTOR AND ATTITUDE DATA AT ORBIT INJECTIONS
 - VERIFICATION OF IUS TO SPACECRAFT SEPARATION EVENT
(This will be a spacecraft requirement, not SSUS requirement)
10. CAPABLE OF BEING SAFED FOR ALL SHUTTLE ABORT AND BACK-OUT CONDITIONS
11. CAPABLE OF HAVING ALL SAFETY CRITICAL ITEMS MONITORED IN THE ORBITER AND BY GROUND LINK DURING ALL PHASES OF SHUTTLE OPERATIONS, INCLUDING NEAR-VICINITY OPERATIONS
12. CAPABLE OF BEING MAINTAINED AND/OR COMMANDED SAFE AT ALL TIMES WHEN IN OR NEAR THE ORBITER
13. PROVIDE AT ALL TIMES SUCH INFORMATION CONCERNING THE STATUS OR CONDITION OF SAFETY CRITICAL IUS SYSTEMS (AUDIBLE AND VISUAL CAUTION AND WARNING) WHILE IN THE ORBITER BAY OR NEAR VICINITY OF THE ORBITER. PROVISIONS SHALL BE MADE FOR ORBITER CREW COMMAND OVERRIDE OF THESE FUNCTIONS FOR ADEQUATE CORRECTIVE ACTION
14. ALL SAFETY CRITICAL DATA, DISPLAYS, AND CONTROLS SHALL BE CAPABLE OF BEING VERIFIED FUNCTIONAL PRIOR TO THE INITIATION OF THE SAFETY CRITICAL EVENT

Table 4-9. EIOUS Checkout Requirements Summary
(Ref: SR-IUS-100, July 1974) (Continued)

15. THE ATTITUDE CONTROL SYSTEM OF THE IUS SHALL BE CAPABLE OF BEING CHECKED FOR ACCURACY BY THE ORBITER CREW BEFORE IUS RELEASE

(The SSUS will not have an attitude control system)
16. IUS PROPULSION SYSTEM START SEQUENCE LOGIC STATUS AND VALVE POSITIONS SHALL BE MONITORED AND MESSAGE SIGNALS SHALL BE PROVIDED AT THE SHUTTLE DATA MANAGEMENT INTERFACE
17. MESSAGE SIGNALS FROM THE IUS SYSTEM SHALL BE PROVIDED AT THE SHUTTLE DATA MANAGEMENT SYSTEM INTERFACE. MEASUREMENTS SHALL INCLUDE IUS LATCHED/RELEASED INDICATIONS, DEPLOY MECHANISM POSITION INDICATIONS, DISCRETE PYROTECHNIC EVENT INDICATIONS, SEQUENCE LOGIC STATUS, VALVE POSITIONS, TEMPERATURE AND PRESSURE MEASUREMENTS, AND FAILURE INDICATIONS
18. COMMANDS AFFECTING SAFETY CRITICAL EQUIPMENT STATUS MUST HAVE ASSOCIATED DATA TRANSMISSION TO PROVIDE A POSITIVE FUNCTIONAL VERIFICATION
19. IUS AUTONOMOUS NAVIGATION COMMANDS FOR ATTITUDE CONTROL AND TRANSLATION MANEUVERS SHALL BE DISABLED UNTIL A SAFE SEPARATION DISTANCE IS ACHIEVED

(SSUS does not have a navigation system. Any spacecraft system can have this requirement imposed)
20. SAFETY CRITICAL CONTROL CIRCUITS SHALL BE CAPABLE OF BEING VERIFIED

Table 4-10. EIUS Major Component Checkout/Monitoring Summary*

TABLE 6. EIUS MAJOR COMPONENT CHECKOUT/MONITORING SUMMARY*

<u>COMPONENTS/SUBSYSTEM</u>	<u>LAUNCH</u>	<u>PRE-DEPLOY</u>	<u>POST-DEPLOY</u>
1. MGC (COMPUTER) (On spacecraft, if needed)	S, O (ACTIVE)	S, O (ACTIVE)	S, O (ACTIVE)
2. IMU (INERTIAL ATTITUDE) (On spacecraft, if needed)	S, O (ACTIVE)	S, O (ACTIVE)	S, O (ACTIVE)
3. RMIS (TELEMETRY) (On spacecraft)	S, O (ACTIVE)	S, O (ACTIVE)	S, O (ACTIVE)
4. DECODERS (On spacecraft)	S, O (ACTIVE)	S, O (ACTIVE)	S, O (ACTIVE)
5. BATTERIES (May be on spacecraft rather than on SSUS)		S, A, O (ACTIVATE)	S, O (ACTIVE)
6. COMMUNICATIONS (On spacecraft)		S, A, O (ACTIVATE)	S, O (ACTIVE)
7. ACS (ATTITUDE CONTROL PROPULSION) (On spacecraft, if needed)		S	S, A, O (ACTIVATE)
8. MAIN PROPULSION SYSTEM		S	S, C, A, O (ACTIVATE)
----- (Additions for SSUS) -----			
(9. SSUS Spinup)		S, A, O (Activate)	S, A, O (Activate) (For any additional spin)
(10. SSUS Separation)		S, A, O (Activate)	

S - STATUS MONITORING
 C - CHECKOUT
 A - ACTIVATION MONITORING
 O - OPERATIONAL MONITORING

* LITTLE REDUNDANCY IS AVAILABLE, NO GROUND OR ONBOARD BACKUP EXISTS. THEREFORE, LITTLE WORK-AROUND EXISTS IN THE EVENT OF EIUS COMPONENT MALFUNCTION

Table 4-11. Orbiter Software Functions To Support EIOUS

1. STATUS PROCESSING
 - a. EIOUS TELEMETRY PROCESSING (16 Kbps)
(SSUS data will be via spacecraft telemetry)
 - b. C&W/SAFETY PARAMETER MONITORING/CONTROL
 - c. SELECTED EIOUS SUBSYSTEM STATUS MONITOR/CONTROL
2. EIOUS ACTIVATION/OPERATION SUPPORT
 - ~~a. IMU STATE VECTOR COMPARISONS~~
 - b. POWER TRANSFER
 - ~~c. NAVIGATION, ATTITUDE AND TIMING UPDATES~~
 - ~~d. COMMUNICATIONS ACTIVATION AND RF LINK VERIFICATION~~
(On spacecraft)
 - e. ~~APS~~ INITIAL ACTIVATION
(For SSUS add activation of spinup, separation)
3. CONTINGENCY SEQUENCING SUPPORT
 - a. ACTIVATION ~~APS, MPS, BATT, COMM~~
 - ~~b. PROPELLANT DUMP, VENTS AND PURGES~~
 - c. ABORT SEQUENCING
4. MISCELLANEOUS ORBITER SUPPORT*
 - a. DEPLOYMENT OPERATIONS
(For SSUS, add pointing)
 - ~~b. REMOTE MANIPULATOR OPERATIONS~~
 - c. COMMUNICATION SWITCHING/RECORDING MANAGEMENT
 - d. EIOUS ATTITUDE-COLLISION AVOIDANCE MONITORING

*NOT CHARGED TO ORBITER SOFTWARE FOR EIOUS

4.4.3.2.7 Ground Network Functions to Support the SSUS

The ground network functions to support EIUS operations are listed in Table 4-12. Similar functions, except when crossed out or indicated in parentheses, are required during spacecraft/SSUS operation.

4.4.3.2.8 Launch Site Functions to Support the SSUS

Table 4-13 lists the launch site support functions during EIUS operations. Similar functions apply for the SSUS.

4.4.3.2.9 Shuttle/Orbiter Control Center Functions to Support the SSUS

Table 4-14 lists the Shuttle Orbiter Control Center functions during EIUS operations. These same functions are performed in support of SSUS operations.

Table 4-12. Ground Network Functions During EIUS Operations

1. SUPPORT PRE-LAUNCH CHECKOUT
2. COMMAND TWO-WAY LOCK IS REQUIRED DURING ALL MISSION PHASES OTHER THAN IN THE ORBITER CARGO BAY
3. GROUND TRACKING, RANGE AND RANGE RATE DATA MUST BE ACQUIRED WHENEVER POSSIBLE TO DETERMINE SPACECRAFT/EIUS EPHEMERIS
- ~~4. REMOTE SITE DATA PROCESSORS (RSDP) WILL PERFORM SPECIAL CALCULATIONS TO SUPPORT CONSUMABLES ANALYSIS AND A VELOCITY COMPUTATIONS~~
(Not required for SSUS - full burns of kick motors)
5. TRACKING, TELEMETRY, AND COMMAND ARE REQUIRED DURING SPACECRAFT OPERATIONS
(Also required during Spacecraft/SSUS operations)
6. POST-PASS ANALYSIS OF DUMPED DATA IS REQUIRED

Table 4-13. Launch Site Support Functions
During EIOUS Operations

1. PREPARATION OF THE SYSTEMS FOR LAUNCH
2. INTERFACE WITH THE OPERATIONAL CONTROL CENTERS ON SYSTEM READINESS
3. ACQUIRE, PROCESS AND ANALYZE PRELAUNCH DATA
4. CONDUCT COUNTDOWN AND LAUNCH OPERATIONS

Table 4-14. Shuttle Orbiter Control Center
Functions During EIOUS Operations

1. VOICE CONTACT WITH THE ORBITER DURING ALL ATTACHED AND NEAR-IN OPERATIONS OF THE EIOUS
2. MAINTAIN CONTACT WITH SPACECRAFT OPERATIONS CONTROL CENTER ~~AND WITH EIOUS OPERATIONS CENTER~~
(The EIOUS Operations Center is not required to support SSUS)
3. MONITOR PRE-DEPLOYMENT CHECKOUT OF EIOUS AND SPACECRAFT

4.4.3.2.10 Orbiter Functions to Support SSUS Operations

The Orbiter functions to support EIUS operations are given in Table 4-15. Cargo bay operations for SSUS include spin-table control and spacecraft/SSUS separation from the Orbiter. The manipulator arm is not required. For the SSUS, the Orbiter aids in pointing before separation.

Table 4-15. Orbiter Functions During EIUS Operations

1.	ORBITER CREW MONITOR AND CONTROL
a.	CARGO BAY OPERATIONS (For SSUS, includes control of spin table and separation)
b.	MANIPULATOR ARM OPERATIONS (Not required for SSUS)
c.	NEAR-IN OPERATIONS
2.	DATA DISPLAY
3.	COMMAND INTERFACE (For SSUS, can include command of spin up, separation, and PKM ignition)

	(Add for SSUS:)
(4.	Navigation, spacecraft/SSUS pointing before release.)

4.4.3.2.11 Spacecraft Operations Control Center Functions
to Support SSUS Operations

Items 1.a. through 1.e in Table 4-16 are the functions of the Spacecraft Operations Control Center to support spacecraft-only operations. Except for 1.e., these same functions are performed for the operation of the spacecraft/SSUS combination. A very significant new function required of the Spacecraft Operations Control Center for operation of the spacecraft/SSUS is command and control after separation from the Orbiter. (The Orbiter may command PKM ignition.)

Table 4-16. Spacecraft Operations Control Center
Functions During EIOUS Operations

- | |
|--|
| <p>1. SPACECRAFT OPERATIONS</p> <ul style="list-style-type: none">a. PRELAUNCH SYSTEMS READINESS VERIFICATIONb. PRE-PLACEMENT SYSTEMS CHECKOUT MONITORING
(TLM FROM SPACECRAFT OR VIA TLM FROM EIOUS)c. MONITOR SPACECRAFT SYSTEMS IN REAL-TIMEd. TRAJECTORY AND EPHEMERIS MAINTENANCEe. ACCEPT, PROCESS AND ANALYZE SCIENTIFIC DATA <p>(2. <u>SSUS Operations</u>)</p> <ul style="list-style-type: none">(a. thru d. For SSUS, Spacecraft Operations Control Center will do Items a-d, above.)(e. Command and control of spacecraft/SSUS system as necessary.)
(Orbiter may be used to command spinup, separation, and SSUS PKM ignition) |
|--|

4.4.3.2.12 Spacecraft Functions to Support SSUS
Operations

Table 4-17 contains the spacecraft functions to support EIOUS operations. Neither of these functions apply for SSUS. For SSUS, the spacecraft must receive commands and distribute them. The spacecraft will provide proper pointing for the spacecraft/SSUS combination. The spacecraft telemetry system will also relay SSUS data to the Orbiter and/or the ground.

Table 4-17. Spacecraft Functions During EIOUS Operations

<p>1. NO INTERFACE WITH EIOUS FOR COMMAND OR CONTROL</p> <p>2. SPACECRAFT DATA THROUGH PUT EIOUS DATA SYSTEM</p> <p>-----</p> <p>(Add for SSUS:)</p> <p>(1. Command receipt and distribution to spacecraft/SSUS combination)</p> <p>(2. Control (pointing, etc.) of Spacecraft/SSUS combination as necessary)</p> <p>(3. Receive SSUS data via hardwire then transmit to Orbiter and ground via spacecraft data system.)</p>
--

4.4.3.2.13 EIUS Operations Center Support of SSUS
Operations

The functions required of the EIUS Operations Center during EIUS Operations are given in Table 4-18. For the SSUS, the EIUS Operations Center is not required. All of the functions in Table 4-18 will be performed by the Spacecraft Operations Control Center.

Table 4-18. EIUS Operations Center Functions During EIUS Operations

- ~~1. ALL SYSTEMS MONITORED DURING PRE-LAUNCH CHECKOUT~~
- ~~2. COMMAND GENERATION, LOADING, UPLINK CONTROL AND COMMAND RECEIPT VERIFICATION~~
- ~~3. TELEMETRY FROM ALL SYSTEMS REQUIRED DURING ALL PHASES OF THE MISSION~~
- ~~4. TRACKING, TRAJECTORY PROCESSING, EPHEMERIS GENERATION, MANEUVER PLANNING~~

(The EIUS Operations Center is not required for SSUS. All of the above functions will be performed by the Spacecraft Operations Control Center.)

4.4.3.2.14 EIUS Operations Functions

The EIUS operations functions, from Reference 1, are summarized in Table 4-19. For SSUS, use is made of the spacecraft command, communications, and telemetry systems.

Table 4-19. EIUS Operations Functions

1.	PRELAUNCH CHECKOUT OF EIUS AND SPACECRAFT REQUIRES ALL SYSTEMS BE GROUND MONITORED - MINIMAL ON-BOARD DEPENDENCE
2.	RELIANCE UPON THE COMMAND SYSTEM IN ALL MISSION PHASES (For SSUS, flight portion of command system is on-board spacecraft)
3.	HEAVY UTILIZATION OF COMMUNICATIONS WITH GROUND CONTROL (For SSUS, flight communications system is on-board spacecraft)
4.	DEPENDENCE UPON ON-BOARD DERIVED TELEMETRY TO PROVIDE INPUTS TO GROUND COMMUNICATIONS (Data from SSUS is supplied to spacecraft TLM system)