

N76-16762

INTERCITY RAIL-PASSENGER CAR  
RIDE QUALITY TEST PROGRAM

Richard L. Scharr  
U.S. DOT/FRA

Raymond P. Owings  
ENSCO, Inc.

SUMMARY

The Federal Railroad Administration's research and development program relating to intercity rail-passenger ride quality focuses on developing ride quality design criteria and specifications. This paper discusses the FRA ride quality test program and some of the techniques being used to analyze and evaluate the design criteria of the program.

PART I--FRA PROGRAMS

The Federal Railroad Administration's research and development program relating to intercity rail-passenger equipment ride quality focuses on developing ride quality design criteria and specifications. This paper will be limited to the ride quality test program and to some of the techniques for analysis and evaluation of design criteria. Only the baseline programs will be discussed in detail.

PASSENGER SYSTEMS R&D PROGRAMS

A portion of the FRA's Office of Passenger Systems R&D programs is oriented toward intercity rail systems. A subprogram under the Suspension, Support, and Guidance Program is the Intercity Rail-Passenger Car Ride Quality Test Program. Two other major programs that include ride quality considerations include Candidate Train Evaluations and the Improved Passenger Train.

Under the Suspension, Support, and Guidance Program is the Intercity Passenger Car Truck Test Program. Current efforts under this program include design of experimental tests, acquisition and analysis of test data, and development of analytical tools to describe ride quality in a form that is useful for design criteria and specifications. Still another program is the Improved Passenger Car Truck which is an effort to improve ride quality on the AMTRAK Metroliners.

## TRUCK TEST PROGRAM

One objective of this 12-month effort is to establish a baseline of coordinated truck and ride performance data. In obtaining baseline data, tests are conducted on six current, relatively new or prototype intercity rail-passenger car trucks that are capable of speeds at least 160 km/hr (100 mph). In coordinating the tests, the same test sequence is used; that is, speeds, track locations, instrumentation, and test cars.

Another objective is to contribute to the establishment of ride quality design criteria and standards. By implication, this program will not necessarily answer all the unknowns. We believe, however, that a compilation of car and truck acceleration, motion, and displacement data of various truck configurations will provide insights which have not heretofore been available. This program is not straightforward, and there are still a number of pitfalls which will have to be skirted, such as the variation in track conditions between each test.

The activities of this program are to place, sequentially, up to six different truck sets (both foreign and domestic) under the same rail-passenger car and test them under the same conditions. The test car and one of the two trucks will be instrumented with accelerometers, displacement transducers, strain gages, pressure transducers, a video camera, and a sound level meter. An adjoining car will collect the physical characteristics of the track. After the data is reduced by the techniques to be discussed in this presentation and by other techniques that may be developed between now and the end of the test program, the effort will be directed toward developing analytical tools and methods for establishing ride quality criteria.

## IMPROVED PASSENGER CAR TRUCK

The Improved Passenger Car Truck program is an effort to assist AMTRAK by improving the ride quality for current high-speed equipment. This objective is accomplished by a new high-speed truck that has completed its test program under a Metroliner car. Another program aimed at achieving an incremental improvement in ride quality on the Metroliner is an upgrade of existing trucks. The secondary coil springs will be replaced by an air bag suspension system, and various damping devices will be changed. The Metroliner is a Federal Railroad Administration demonstration program that, since 1968, has been directed at evaluating traveler response to improved intercity railroad passenger service.

## TRAIN EVALUATIONS

The Passenger Train Evaluation Program represents still another area in which ride quality is a part of the effort. The FRA intends to prepare a specification, in coordination with

AMTRAK, for a new train system that will be called an Improved Passenger Train (IPT). The specification will outline a major subsystem program to determine technological requirements and deficiencies. Parallel with this effort, there are six non-U.S. built prototype or new-in-production train systems that will be evaluated to establish the capabilities of currently available new equipment, including ride quality. Many of the present techniques for collecting and reducing ride quality information, which are common to other ride quality test programs, will be used during these train evaluations. This information will add to the data bank of ride quality information.

## RIDE QUALITY CRITERIA AND SPECIFICATIONS

Figure 1 illustrates, in general, the steps we will complete to arrive at our ride quality objectives which, in turn, will assist AMTRAK to define its specification requirements for ride quality. The left side of the figure illustrates that we are observing current equipment tests, such as the FRA truck improvement tests, and the tests on new intercity rail-passenger equipment that AMTRAK is currently conducting. We also are reviewing specifications, such as those for the Metroliner prepared in 1965. Along with this, we plan to review the specific designs that these specifications have produced.

Next, we are developing and improving the ride quality data acquisition techniques and methods of collection, reduction, presentation, and analysis. The literature review is a necessary part of this phase of the effort. The human factors portion is shown separately from our effort, because the Research and Technology Office of the Secretary of Transportation has a multimodal program which we are following and which will certainly have an impact on our ride quality programs.

At the present time we are involved with the design of experimental tests, data acquisition and reduction, and analysis and development of analytical tools and methods (next three activities in Figure 1). We believe that methods for specifying ride quality will evolve, at which time a hypothesis can be tested and validated. Once the methods are validated, the ride quality criteria and model specifications will be prepared, and AMTRAK will have the option either to use the information directly or to modify it for various intercity rail-passenger equipment. If the new rail equipment encompasses an R&D program, it may become an FRA development program that would be coordinated with AMTRAK. If the equipment is a straightforward state-of-the-art train system or cars, it would be an AMTRAK procurement. In the first case we would conduct the ride quality verification; in the second case we would obtain the data from AMTRAK or assist them in verifying ride quality performance.

We have briefly covered the program aspects of the intercity rail-passenger ride quality efforts FRA is undertaking. Now we will shift to a problem statement, and then summarize the current ride quality specification requirements and discuss the multiplicity of what has been required or requested.

#### PROBLEM STATEMENT

First, we do not have an efficient way of describing how much ride quality should be built into the equipment for the cost or how much flexibility or rigidity in an application should the equipment have designed into it. Second, it is difficult to define ride quality and what is "better." Ride quality literature is replete with conflicting views and results and different approaches to this complex subject. Thus, we need a better way to define ride quality or establish criteria on what kind of ride quality we want. With regard to the last part of the second element, What is better? possibly the designer will eventually determine quantitatively a zone of indifference for the particular application and thereby determine the most cost-effective ride quality elements that should be included in a particular new design. This will bring in the trade-off elements of human factors, ride motion, and cost.

#### SPECIFICATION DESIGN VALUES

Table I summarizes the ride quality requirements taken from current intercity passenger equipment specifications. Included in the table are the ride quality specification requirements of the Prototype Tracked Air Cushion Vehicle--the PTACV. The PTACV is a 240 km/hr (150 mph) FRA developmental air-cushion vehicle that is being tested at the DOT Transportation Test Center in Pueblo, Colorado.

The values in this table point out the different ways that ride quality acceleration information has been expressed in specifications. If this small sample is representative, the tendency has been to shift from time-domain requirements to frequency-domain requirements, or to specify both. The specification for the AMTRAK Bi-Level Car expresses ride quality in the frequency domain, but not to some absolute levels. Note the comparison with another rail car--the Hi-Level car. This comparative test is an effort to circumvent the track as a variable. Also note that different test equipment locations are cited. Standardization of location should be achieved in order that more comparative information would become available.

In summary, if we can better define or describe ride quality or ride comfort in terms of what is desired, then possibly we can provide a more cost-effective and pleasant ride for the intercity rail passenger.

TABLE I. SPECIFICATION RIDE QUALITY ACCELERATION DESIGN VALUES (PARTIAL REQUIREMENTS)

Equipment	Speed km/hr (mph)	Data Domain	G's Vertical	G's Lateral	G's Longitudinal	Test Equipment Location	Track Condition Reference
Metroliner (1965)	256 (160)	Time	0.03 Frequently 0.05 Occasionally	0.02 0.04	0.02 0.04	Floor over truck and mid- point	Geometric limits
AMCARS (1974)	152 (95)	Time	0.050 (99% of Time)	0.060 (99%)	0.010 (95%)	Over truck and midpoint	Referenced test run and PSD
Bi-Level car (1974)	24-176 (15-110)	Frequency	← 20 Sec. Data → Bi-Level Car PSD comparison to Hi-Level car (run in same test)			Over truck and midpoint at seat height	-----
LRC (Canadian) (1974)	152 (95)	Time	0.070 (99% of time)	0.057 (99% of time)	-----	Over truck	Class 5 or 6
Prototype Tracked Air Cushion (FTACV)	240 (150)	Time and Frequency	← 10 Sec. Data → 0.094 (95% of time) PSD specified, 0.1 to 50 Hz			Passenger compartment	Guideway condi- tions specified
				≤ 30 Sec. Data →			

## PART II--ENSCO RESEARCH IN SUPPORT OF FRA PROGRAMS

The purpose of developing the capability to measure and analyze vehicle acceleration data is to provide a means of evaluating the ride quality of rail vehicles and to provide information for the establishment of meaningful guidelines for vehicle designs. While ENSCO is not involved in basic research of perceived ride quality, we are interested in the results of basic research in this area and how this information might be applied to the development of ride quality specifications for rail vehicles.

### DATA COLLECTION

A portable data collection system, known as the Portable Ride Quality (PRQ) package (Figure 2), has been developed for the Federal Railroad Administration by ENSCO. This system consists of a magnetic tape recorder, a conditioning and coding unit, and an accelerometer package. The accelerometer package contains six accelerometers three linear and three angular. Table II provides details of this package.

TABLE II  
CHARACTERISTICS OF ACCELEROMETERS

Measurement	Full-Scale Capability	Natural Frequency
Vertical	$\pm 1$ G	60 Hz
Longitudinal	$\pm 1$ G	60 Hz
Lateral	$\pm 1$ G	60 Hz
Yaw	$\pm 1$ Rad/Sec	30 Hz
Pitch	$\pm 1$ Rad/Sec	30 Hz
Roll	$\pm 5$ Rad/Sec	30 Hz

The conditioning and coding unit converts the current output of each accelerometer to a proportional signal voltage suitable for recording. The unit provides metering for signal monitoring and calibration. It also contains batteries and associated charging and regulator circuits, which provide power to the system during portable operations.

The magnetic tape recorder accommodates eight channels of data. Six channels are used for recording accelerometer signals; one channel is used for voice annotation; and one channel is used for a multiplex recording of two external data signals, an internally generated digital annotation and a reference signal for wow and flutter compensation. The total weight of the system is approximately 41 kg (90 pounds).

A signal reconstruction unit is used in the playback mode of operation. The unit conditions all signals to a level comparable with data processing, and provides wow and flutter compensation. A block diagram of the PRQ system is shown in Figure 3.

Many problems arise in specifying the conditions under which ride quality data is to be collected. These problems involve:

- Speed or speeds of the vehicle
- Duration of recorded signals
- Track conditions
- Position of the accelerometer package in the vehicle

Answers to these problems will depend on the purpose of ride quality experiments and the analytical procedures applied to the data.

#### DATA REDUCTION

The recorded analog signals are converted to digital form for data reduction. The digitizing process involves anti-alias filtering of the data and conversion of the filtered analog data into 12-bit digital words. The conversion rate or sampling frequency in this process occurs 256 times per second. The digitized data in this form is compatible with a number of data reduction techniques, including both frequency domain and time domain. Methods used to reduce the data include:

- Histograms
- Standard deviations
- Cumulative distribution functions
- Density functions
- RMS time plots
- Power spectral density (PSD)
- One-third octave band filtering
- DC bias versus time

The block diagram for time-domain data reduction is shown in Figure 4. A digital high-pass filter is used to remove any DC bias in the accelerometer signals. The rationale for choosing these methods is that:

- (1) Histograms provide information on the distribution of the acceleration levels, including peak acceleration. Estimates of the distribution function and the density function can easily be produced from the histograms. The data presented by these functions represent more usable forms for some applications.
- (2) Standard deviations can be easily generated from the histograms and serve to define the signal in the time domain.
- (3) RMS time plots provide a short-term average of the accelerations. Special events (i.e., large accelerations of significant deviations) can be quickly determined.

For the frequency-domain process, two methods of reduction are applied to the data. A block diagram for frequency-domain processing is shown in Figure 5. The first is a narrow-band type of processing that presents results in PSD form. Typical processing bandwidths are 0.1 Hz to 0.25 Hz. A typical PSD for ride quality data collected on passenger trains is shown in Figures 6 and 7.

The second method of frequency-domain processing is with one-third octave band filters. In this type of processing, the bandwidth increases with frequency. One-third octave band filtering is the appropriate method for applying the International Organization for Standardization Standard (ISO) 2631 for ride quality.

#### COMFORT CRITERIA

The one-third octave band frequency technique and the ISO Standard provide a method of applying a signal number to the measured vibration environment. The RMS G levels corresponding to the one-third octave bands between 1 Hz and 80 Hz are determined. Using the reduced comfort criterion from the ISO Standard, these values are converted to exposure limits. Exposure limits are measured in hours. An exposure limit of 5 hours means that a passenger experiences "reduced comfort" after being exposed to the vibration environment for a period of 5 hours. The minimum exposure time for the entire frequency range is taken as a single description of the ride. Results of this type are shown in Figure 8.

In correlating the results of ride quality test programs, we have found that much of the vehicle vibration data is presented in PSD form. Comparison of PSD's is difficult. One useful tool for comparison of ride quality data is to translate the ISO ride quality standard into an equivalent PSD form. The assumption in making this conversion is that the power in each of the one-third octave band filters is evenly distributed.



The resultant form of the ISO standard is shown in Figure 9 for the head-to-foot (vertical) direction and in Figure 10 for the side-to-side (lateral) direction. Also shown in these figures are PSD's for the lateral and vertical accelerometer data collected on a Metroliner passenger car. For the vertical direction, an exposure time of 4 hours at a frequency of 5 Hz is obtained. For the lateral direction, an exposure time of 8 hours at a frequency of 2 Hz is obtained. These results are similar to those for the one-third octave band filtering method.

While the PSD form of representing ride quality data provides a convenient method of condensing long time records of ride quality data, it tends to mask special events. By special events, we mean periods of high acceleration levels and significant duration. Time-domain processing can be used to account for special events. For rail vehicles, special events are usually related to "bad spots" in the track. One method of addressing this problem is to determine the percentage of time that the magnitude of the acceleration signal exceeds a given value or, conversely, the magnitude of the signal which brackets some fixed percentage of the data. The difficulty with this technique is that the duration of the peak acceleration levels is not taken into account (i.e., are the peak accelerations isolated spikes, or do they occur during a single period of high acceleration). Obviously, the results of this type of processing will depend on the bandwidth of the processing system. By calculating the RMS value of the accelerometer signals, the effect of duration can be seen, but again the bandwidth of the signal is an important factor. From experience, a bandwidth of 1 to 15 Hz appears appropriate for rail vehicles.

Table III shows a comparison of two Metroliner vehicles using both the ISO ride quality standard and time-domain processing. This data was collected between Baltimore and Wilmington. For the northbound run, the test zone was between milepost 35 and 40; for the southbound run, the test zone was between milepost 81 and 83. The accelerometer package was located on the floor in the center of the car. The Metroliner 850 vehicle was equipped with an improved truck design, while the 855 was a standard vehicle. The performance of the 850 vehicle is superior for all comparisons.

#### TRACK GEOMETRY

A means of describing the track conditions is required to correlate the results of ride quality experiments. Since both the vehicle vibration environment and the sensitivity of the passenger to vibration can be described in PSD format, it is convenient to use this format for describing track geometry. The PSD allows a three-way comparison of: the input to the vehicle, the output of the vehicle, and the sensitivity levels of the passenger. Track geometry data is usually collected with a distance-based data collection system, with the reduced data presented in the format

TABLE III. - METROLINER RIDE QUALITY TEST RESULTS

Type of Measurement	Vehicle	Northbound		Southbound	
		Vertical	Lateral	Vertical	Lateral
Standard Deviations**	850	0.031 G	0.024 G	0.027 G	0.024 G
	855	0.045 G	0.026 G	0.040 G	0.030 G
99% Level**	850	0.098 G	0.068 G	0.088 G	0.073 G
	855	0.037 G	0.083 G	0.111 G	0.085 G
95% Level**	850	0.064 G	0.050 G	0.055 G	0.051 G
	855	0.090 G	0.060 G	0.080 G	0.060 G
ISO* Reduced Comfort Criterion	850	4.0 hr (5 Hz)	13.8 hr (2 Hz)	4.95 hr (5 Hz)	15.9 hr (2 Hz)
	855	2.5 hr (5 Hz)	9.2 hr (2 Hz)	4.36 hr (5 Hz)	8.48 hr (1.3 Hz)

Vehicle 850 = Metroliner with improved truck design

Vehicle 855 = Standard Metroliner

\* 128 seconds of data

\*\* 60 Hz bandwidth

Speed 170 km/hr (106 mph)

in centimeters squared per spatial frequency versus spatial frequency. The format can be converted to the form of  $\text{cm}^2/\text{Hz}$  versus frequency by assuming a constant vehicle speed. To convert this form to the desired form requires that each point of the curve be multiplied by a factor of  $(2\pi F)^4$  and that the acceleration level in  $\text{cm}^2/\text{sec}^4$  be converted to G's. This operation in the frequency domain is equivalent to double differentiation of the track profile data. The process is shown in Figure 11.

Track geometry parameters of interest include mean profile, mean alignment, and crosslevel. Typical PSD curves for mean profile, mean alignment, and a 128-km/hr (80-mph) speed are shown in Figures 12 and 13.

The ISO curves for reduced comfort have been added to these figures. Note the peaking of the PSD levels at frequencies of 3 Hz, 6 Hz, 9 Hz, and 12 Hz. At 128 km/hr (80 mph), the 3-Hz frequency corresponds to a wavelength of 11.88 meters (39 feet) in the track (the basic length for bolted rail). The remaining frequencies represent harmonics of the encounter frequency. The interpretation of these curves is that the input from the track must be attenuated by the suspension system of the vehicle to lie below the appropriate exposure time curve. For ride quality tests performed on different sections of track, the relationship between the track input and the ride output (vehicle acceleration data) can be used to normalize the results of the test programs.

#### CONCLUSION

A number of data-processing techniques have been presented for reducing and analyzing vehicle acceleration data. The common format of PSD representation of track geometry, human tolerance, and vehicle response will be used to investigate and compare the "ride quality" of a number of vehicle designs. In addition, a number of time-domain techniques have been developed to investigate vehicle ride quality.

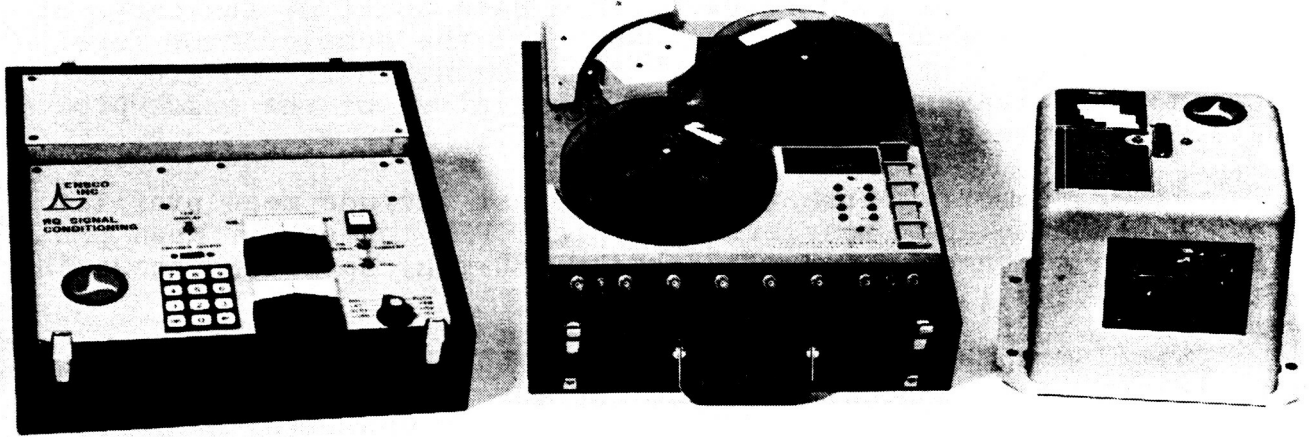

Figure 1.- Ride quality criteria and specifications.

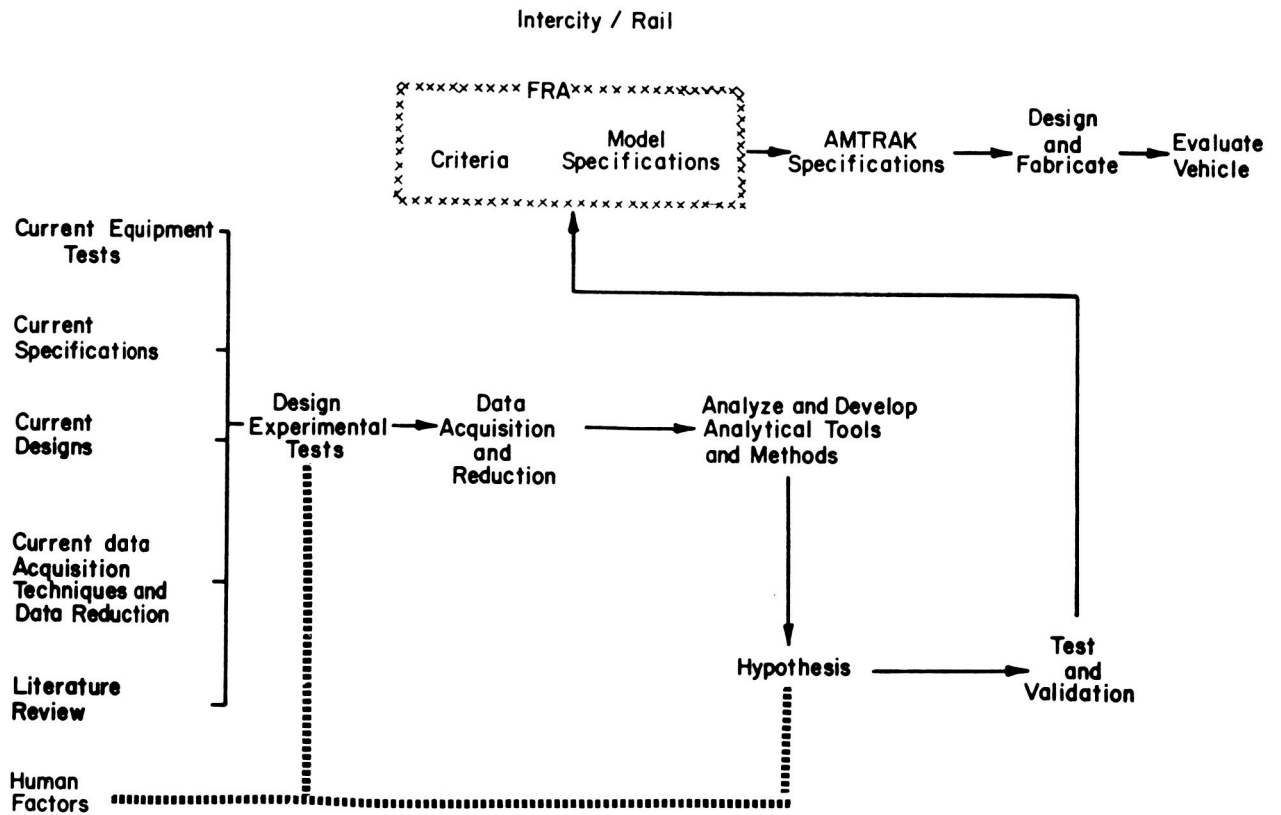

Figure 2.- Portable ride quality system.

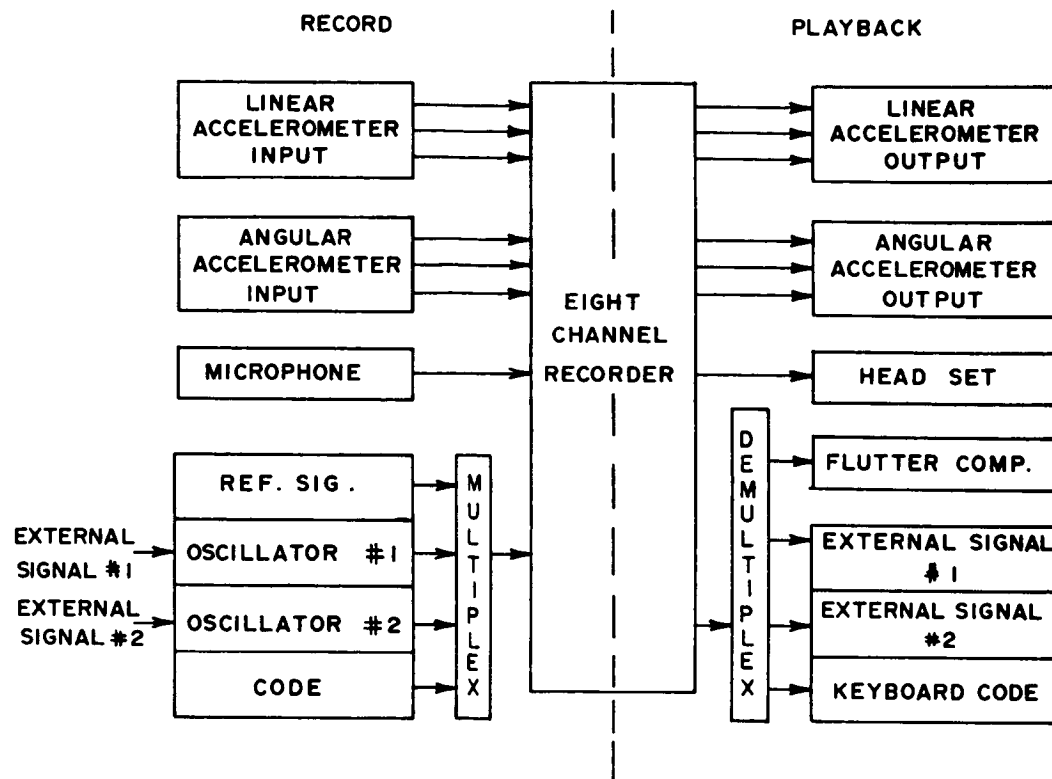
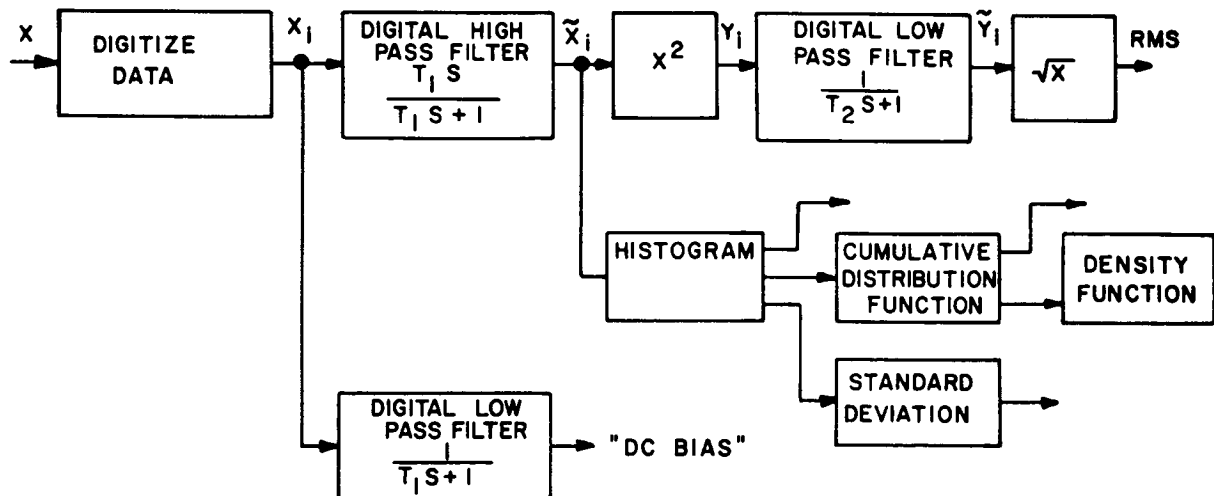
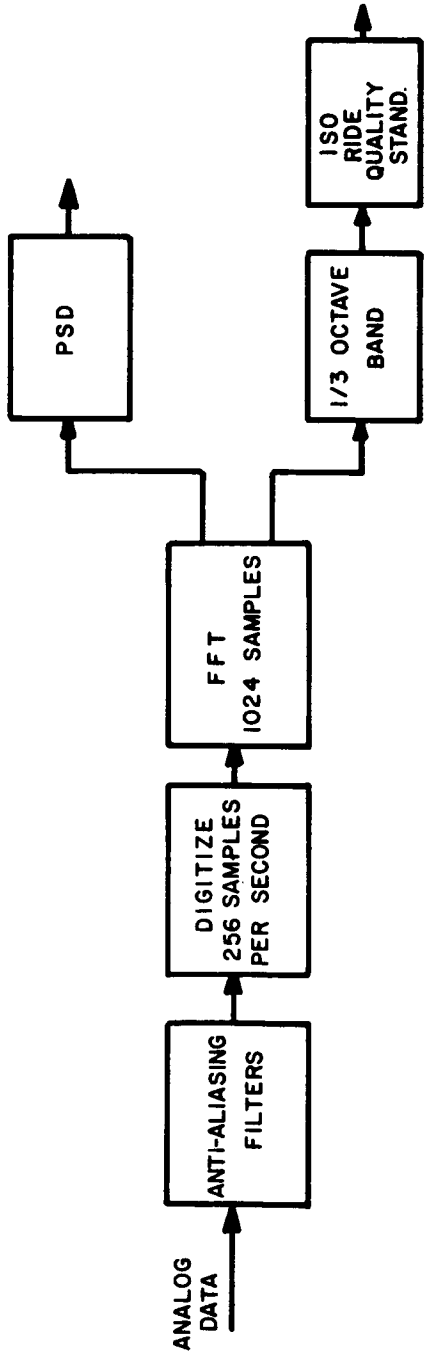

Figure 3.- Block diagram of portable ride quality system.



S = LAPLACE OPERATOR  
 $T_1 = T_2 = 0.33$  SECONDS

Figure 4.- Block diagram of time-domain processing.



FFT - FAST FOURIER TRANSFORM

Figure 5.- Block diagram of frequency-domain processing.

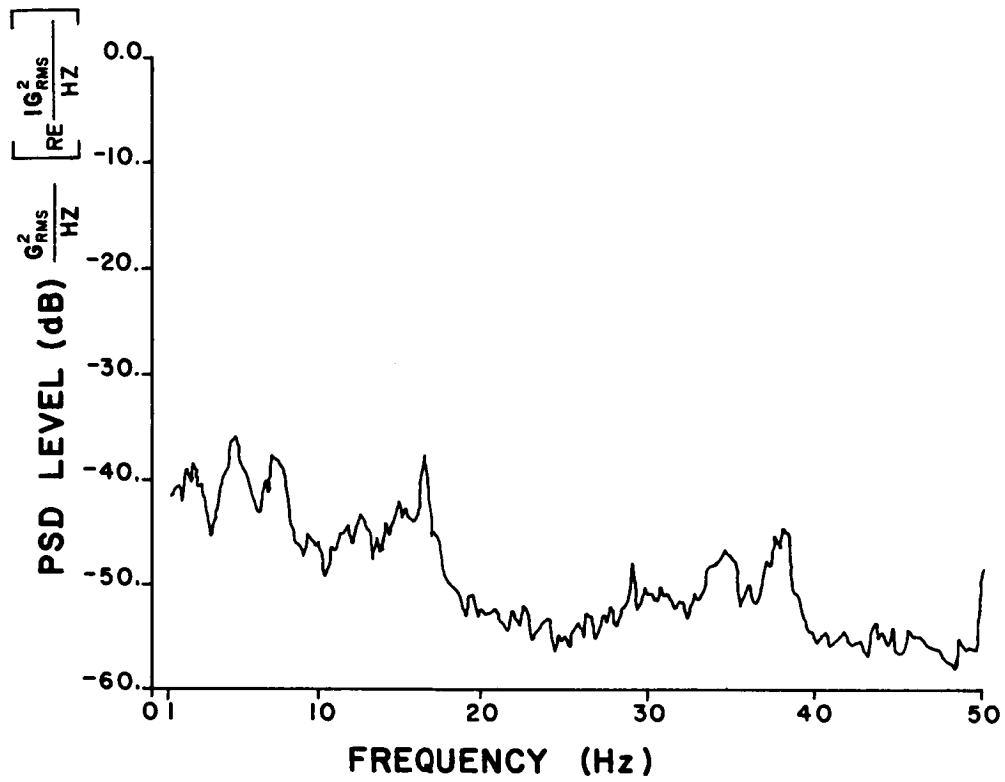

Figure 6.- PSD for vertical acceleration.

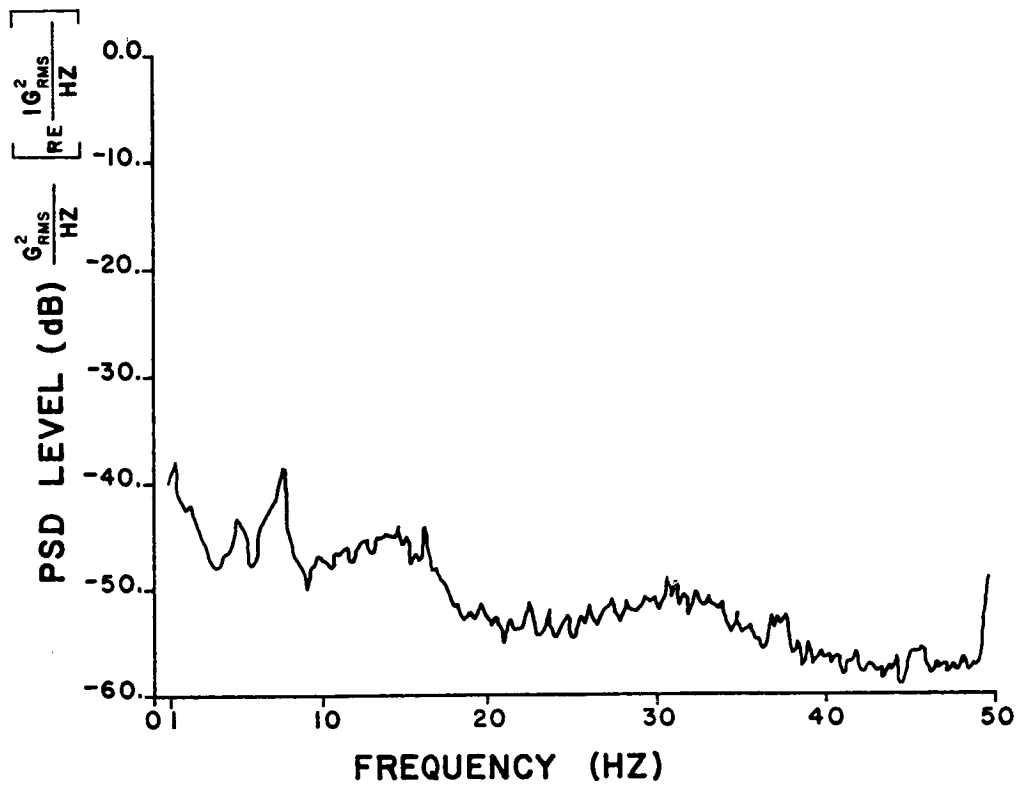

Figure 7.- PSD for lateral acceleration.

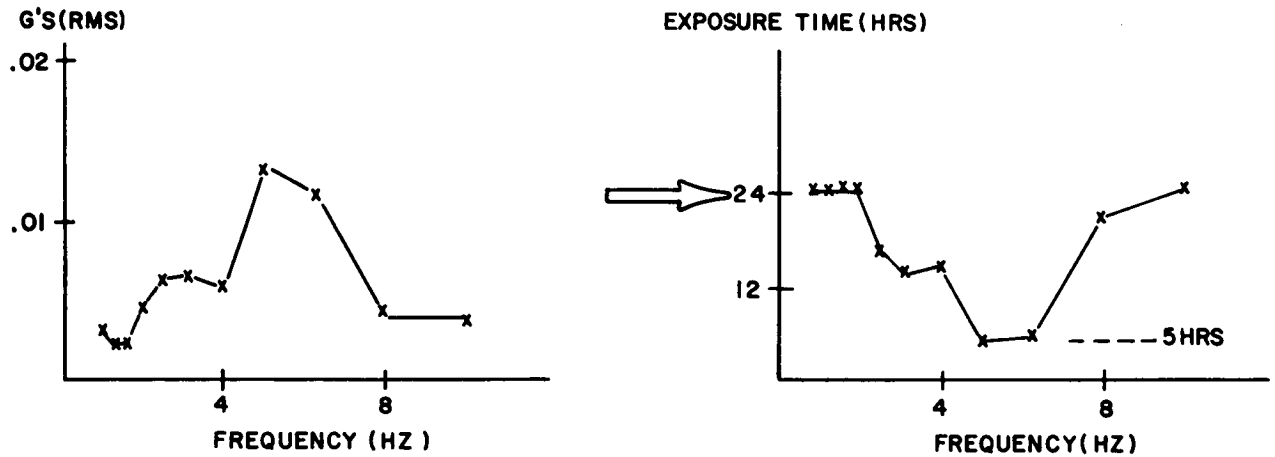

Figure 8.- ISO ride quality standard for random vibration.

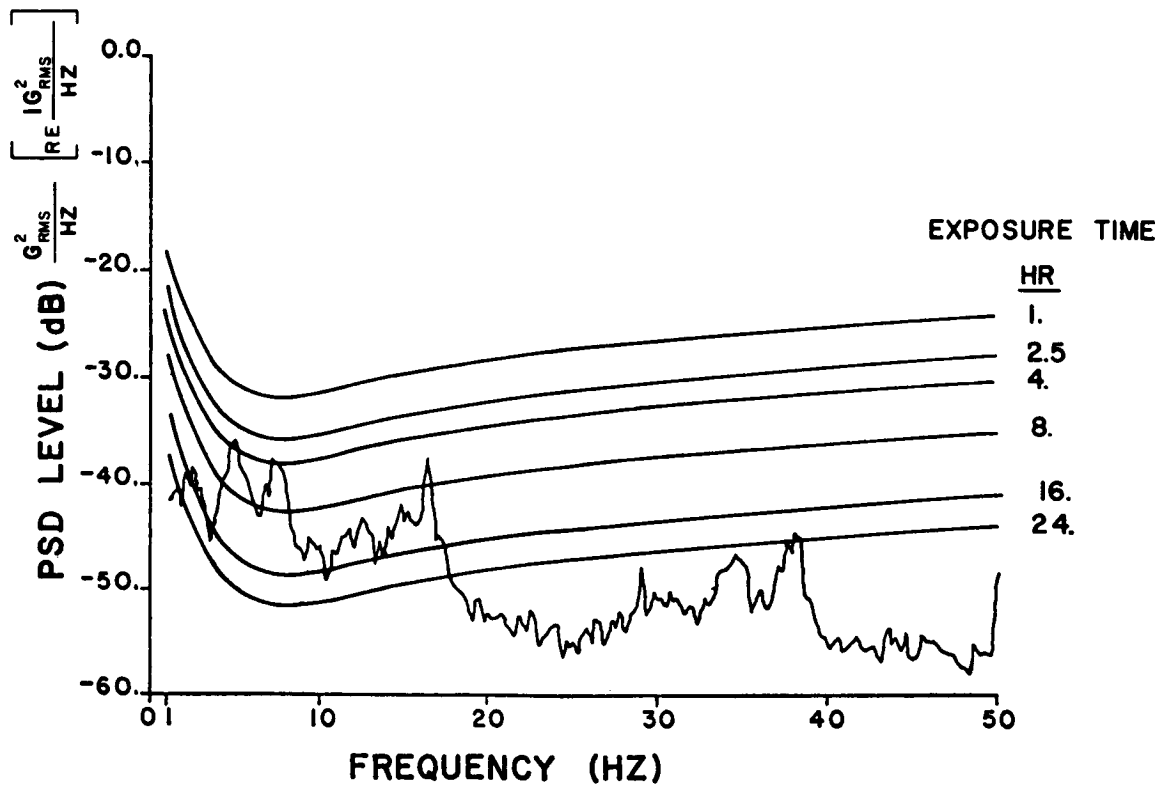

Figure 9.- PSD curve for vertical acceleration with ISO Standard overlay.



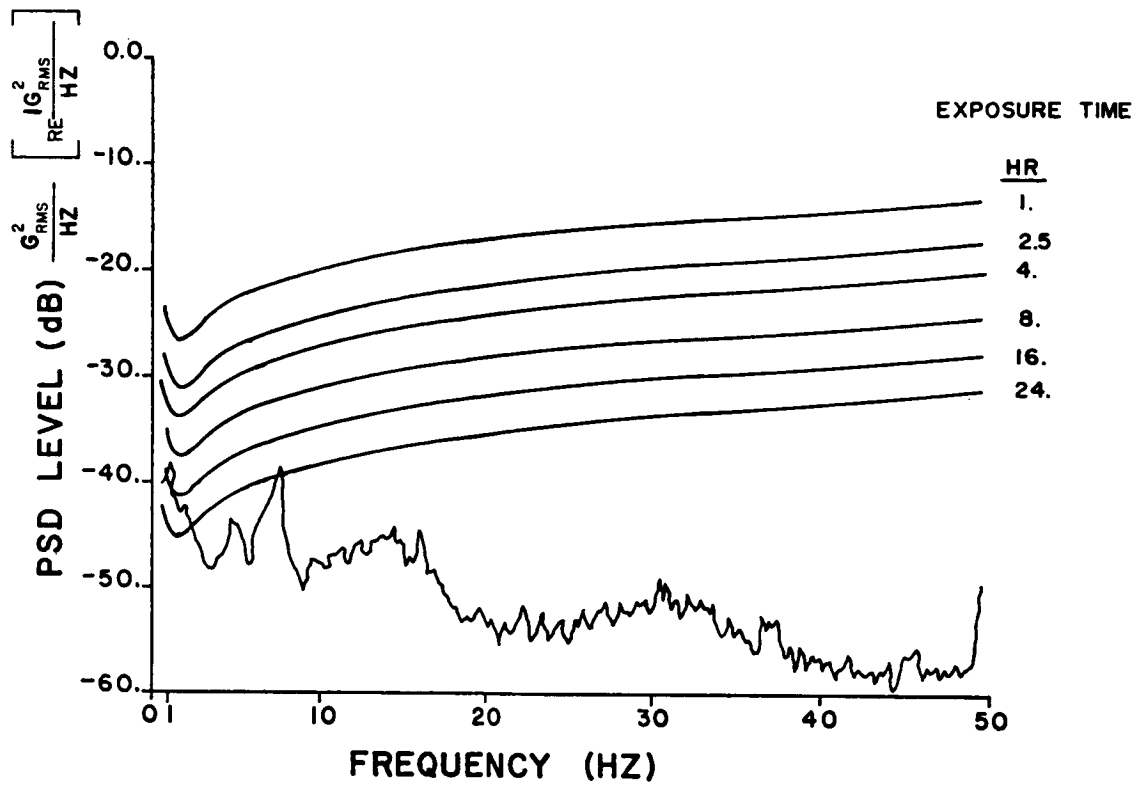

Figure 10.- PSD curve for lateral acceleration with ISO Standard overlay.

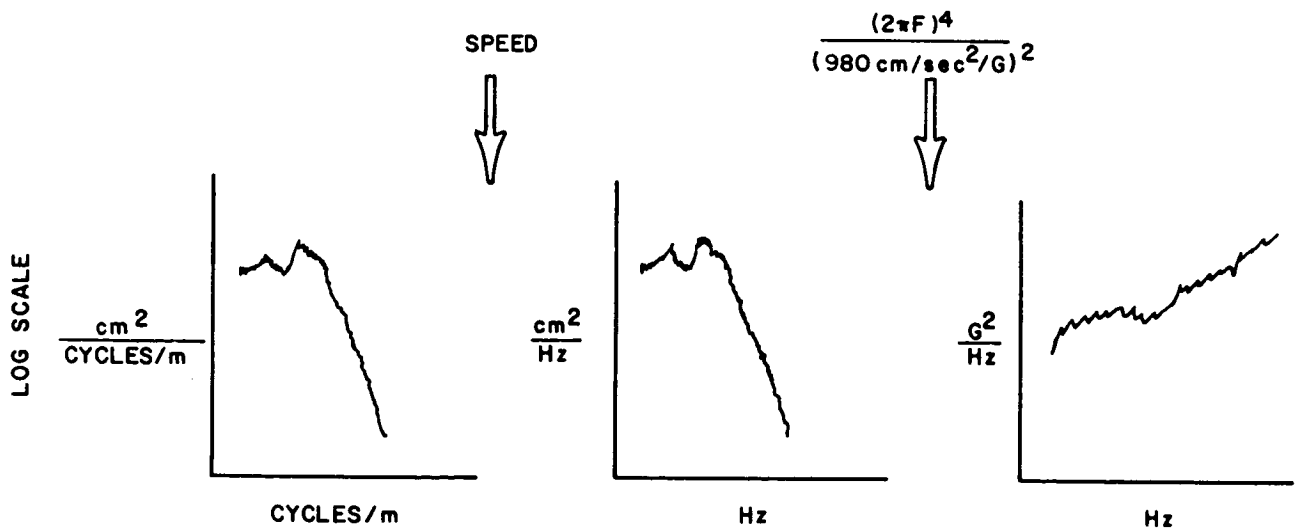

Figure 11.- Conversion of track geometry data from distance-based format to PSD format.

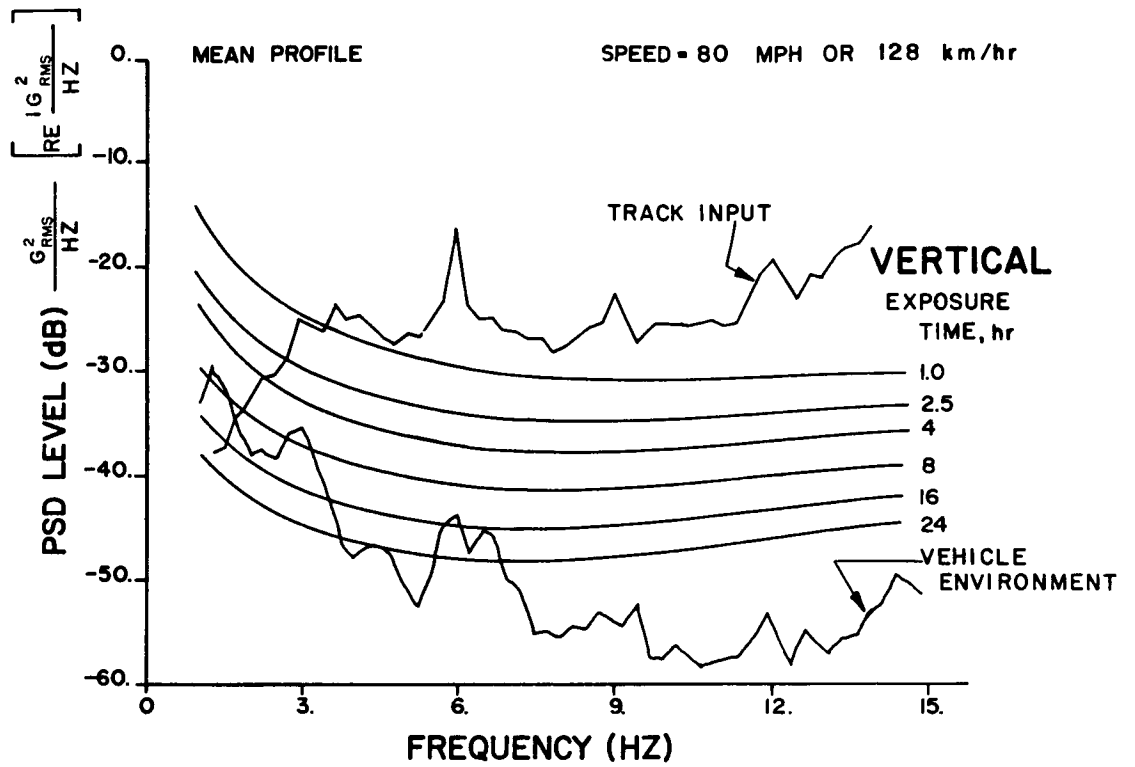

Figure 12.- PSD curve for mean profile with ISO Standard overlay.

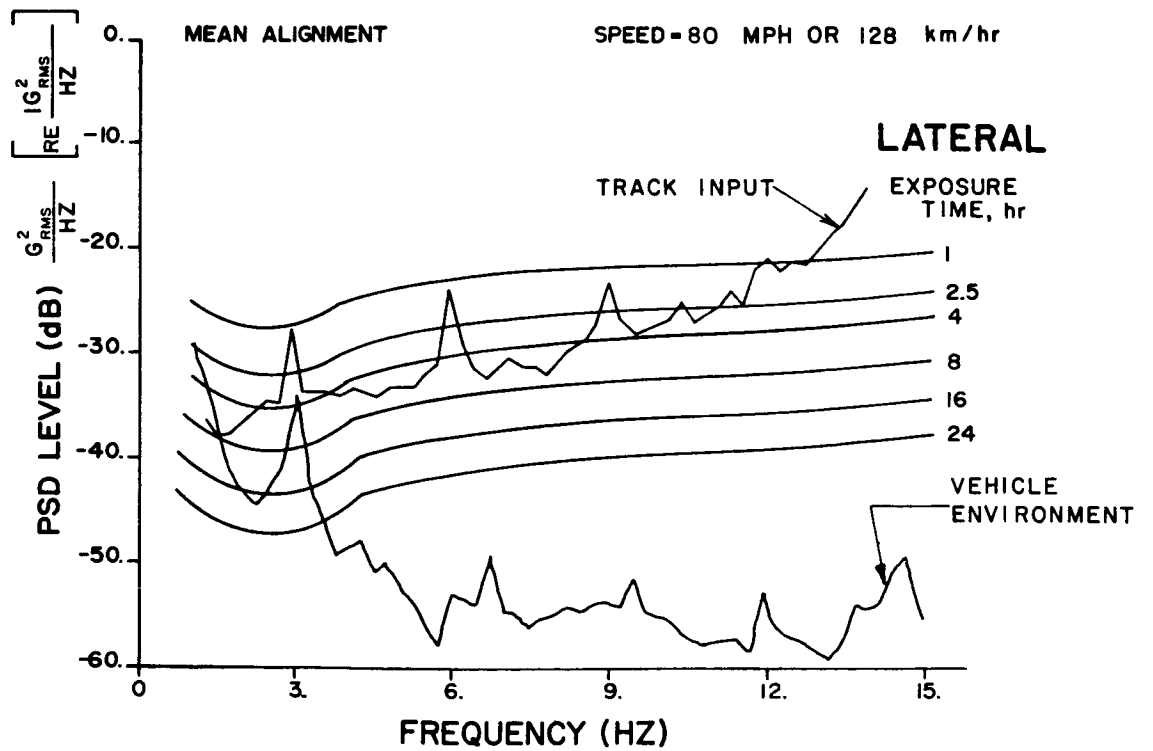

Figure 13.- PSD curve for mean alignment with ISO Standard overlay.