

N76-19192

20. DEVELOPMENT OF A BONE-FIXATION
PROSTHETIC ATTACHMENT

By Lester J. Owens
NASA Kennedy Space Center

SUMMARY

The first of what promises to be a new generation of prosthetic devices-- an artificial limb attached directly to the bone by a quick-disconnect coupling-- is undergoing in-place testing at a California medical rehabilitation center. This paper describes its design concept and development, made possible by multiple spinoffs of aerospace technology.

INTRODUCTION

Man's experience in the design and fabrication of prostheses dates to prehistoric times, when some cave-dwelling amputee created the first artificial leg by binding a piece of tree branch to his stump. Since then, and particularly within this century, many advances have been made in the state of the art. However, artificial arms and legs of today still have to be strapped or clamped on the amputee's stump in a manner not unlike that of the olden days.

Thus, it was with a considerable sense of challenge that the writer, a member of the NASA Kennedy Space Center Design Engineering staff, responded to a request to help design a quick-connect, strapless prosthesis. The request was made by Dr. David B. Hartmann, a member of the staff of Rancho Los Amigos Hospital in Downey, California, during a visit to KSC in March, 1973. Over a period of years this Los Angeles County hospital has worked closely with NASA and the aerospace industry in a continuing technological exchange.

Months ago, the hospital's Amputee and Fracture Service chief, Dr. Vert Mooney, announced that research at the institution had shown the feasibility of using aerospace-developed biocompatible carbon for "direct skeletal attachment of limb prostheses." Heretofore, direct prosthetic attachment had been thwarted by the body's tendency to reject foreign materials and the failure of the skin to form a hygienic seal around otherwise compatible material.

Now, the medical researchers hoped for a workable prosthetic design utilizing a bone-implanted connector accessible through a biocompatible carbon collar around which the flesh and skin would heal. This led to Dr. Hartmann's request and the launching of the project described herein.

CONCEPT DEVELOPMENT

Development of the new prosthetic attachment concept began with consideration of the basic problem of finding a quick-disconnect method suitable for use with a person's bone. Aerospace technology quickly suggested the ball-lock connector, a familiar item in missile and space programs for several years. These quick-disconnect devices have served reliably to hold umbilicals and even complete space vehicles in place until the desired instant of release.

The ball-lock mechanism is simple and effective. In a typical device, balls captivated in holes near the point of the locking pin are forced to protrude from the shaft surface by a spring-loaded rod inside the pin. When the pin is inserted into its receiver, the balls encounter and lock into an annular groove. The pin cannot then be withdrawn until a release is pressed, moving the rod inside the pin to permit the balls to retract into cavities in the rod shaft.

Ball-lock devices are made in a variety of styles for aerospace applications. They normally range in diameter from 3/16 inch to 1 inch, although the Saturn V is released by four 3 1/2-inch pins. A four-ball stainless-steel ball lock of 1/2-inch pin diameter can carry approximately 102,300 newtons (23,000 pounds) in shear and 6,670 newtons (1500 pounds) in tension.

The medical researchers quickly accepted the simplicity of a ball-lock prosthetic disconnect, and the conceptualization of the new prosthesis was expedited as follows:

The male half of the disconnect device, containing the ball-lock pin and release mechanism, would be part of the prosthetic limb. The female half--the receiver--would be implanted surgically in the medullary canal of the bone remaining in the amputee's stump. A sleeve or collar of biocompatible carbon would be bonded around the distal end of the receiver insert to provide a permanent passage through the skin.

This connection concept would be usable wherever stump size permitted a receiver implant, including arm and leg locations above and below the elbow and knee. Hopefully, it would benefit many amputees with stumps too short for conventional strap-on or clamp-on prosthetic limbs.

DESIGN DEVELOPMENT

The announcement early this spring that an amputee at Rancho Los Amigos Hospital had volunteered for implant surgery spurred the development of a working prototype of the quick-disconnect prosthesis. Work was concentrated at KSC to provide a suitable ball-lock receiver and subsequently the associated hardware for a lower-leg prosthesis. A basic design was standardized using ball locks of three pin sizes: 1/4-, 5/16-, and 3/8-inch.

The receiver design (Figure 1) was influenced by consideration of Young's modulus of bone elasticity and corresponding moduli for the steel implant and an acrylic plastic, methylmethacrylate, which would be used as an insulator and bond between the implant and the surrounding bone. These moduli were calculated to be approximately 2×10^{10} , 2×10^{11} , and 4×10^9 newtons/meter² respectively. The lower modulus of the methylmethacrylate allows a transfer of bearing loads between the implant and the bone; the ogival contouring of the receiver was designed to provide decreasing load transfer toward the bone end and to avoid stress concentrations. The toothed, grooved shaft of the receiver enhances its seating in the bone canal with optimum distribution of the semi-fluid methylmethacrylate and gives mechanical interference with the plastic against pull-out and rotation within the bone.

Type 316-L stainless steel, previously proven biocompatible, was selected as the receiver material. Implant dimensions were determined by the writer through reference to Gray's Anatomy; they were subsequently approved by hospital personnel. The interior design provides a second ball-locking groove against the possibility that wear or future adjustments might require this backup feature, as the receiver could not easily be replaced. The unused groove would be filled in with an epoxy that could be removed cleanly with a dental pick when required. The epoxy would prevent wearing of the groove and facilitate cleaning of the receiver, which could be done simply with a swab and alcohol.

The finished implant device, complete with its biocompatible carbon collar and plastic plug, is shown in Figure 2. The protective plug would be used during the implant operation and recovery period and could be used afterwards during periods of prosthetic disconnection. The carbon collar was manufactured by Gulf General Atomic Corporation. Hospital experts developed the collar design to provide optimum healing and implant support. The circumferential holes are intended to promote tissue growth about the stump end.

The remaining design work was encouraged by the initial success of the implant operation, which was undertaken in March of this year. Figure 3 is a view of the healing leg stump showing the receiver in place.

Development of the prosthetic attachment involved the writer in a design effort to produce a mounting assembly containing not only the male portion of the ball-lock mechanism but also adequate shock-isolation provisions. The importance of the latter was emphasized by the belief that rejection of previously attempted implants may have resulted from shocks and stresses to the bone at the implant interface. It was decided to provide a coaxial shock absorber mount extending from just below the connection point into the main support column of the prosthesis.

Experimentation with various techniques and materials led to the development of the shear-radial isolation mount shown in Figure 4. This is formed by bonding an elastomer (silastic rubber) between aluminum cylinders that are threaded to provide adjustment capability.

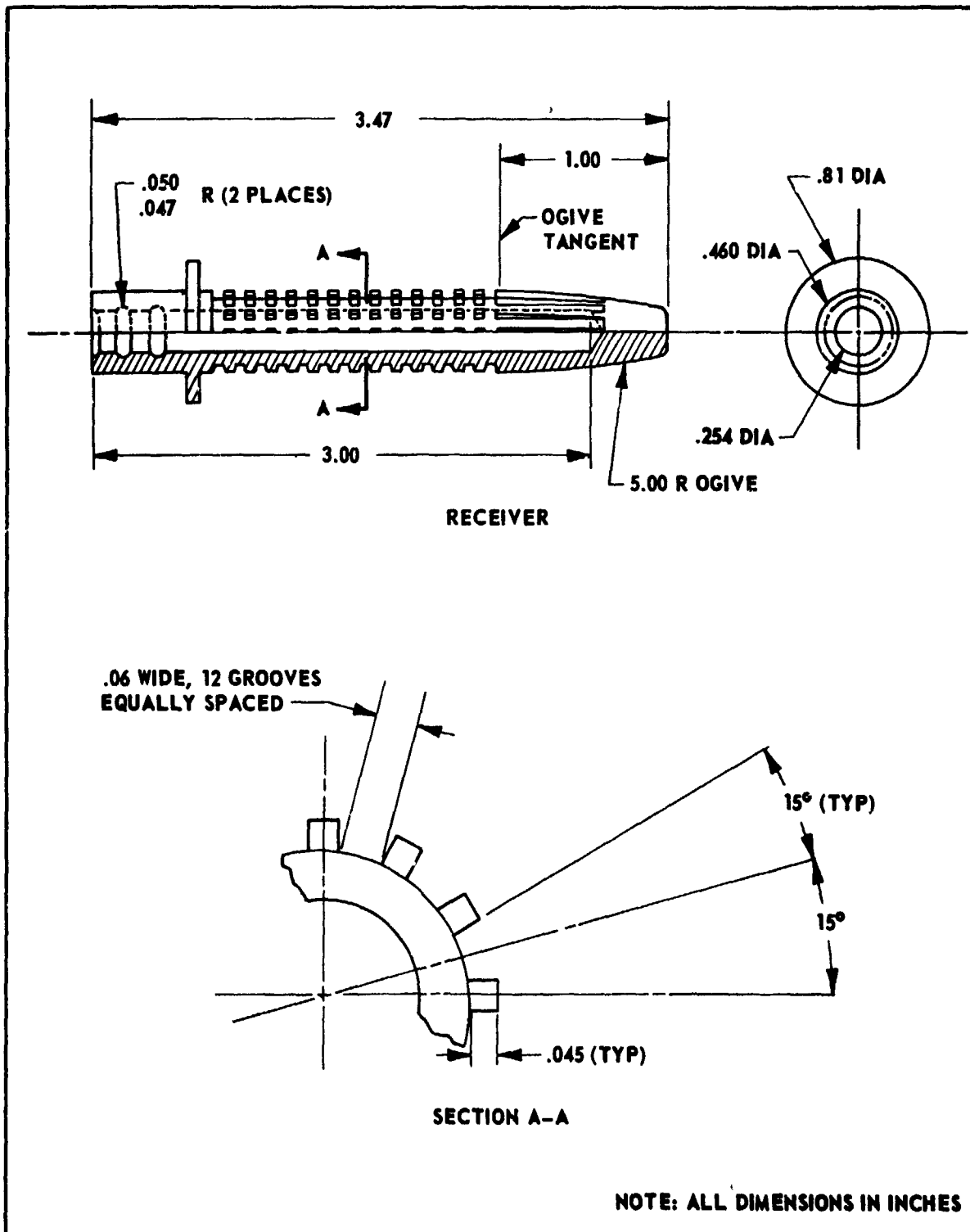

Figure 1. Receiver Implant Design (Extracted from Manufacturing Drawing)

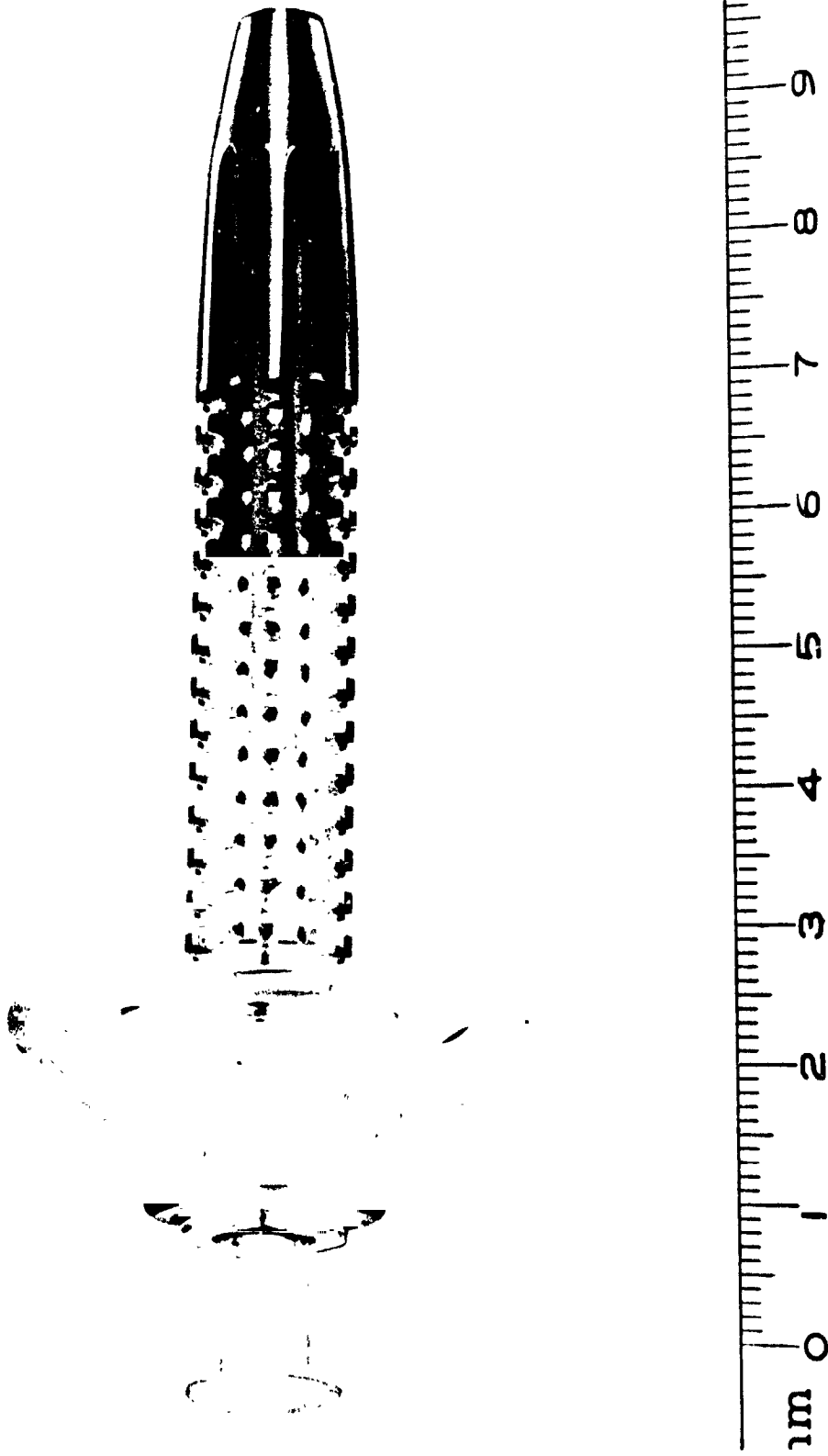
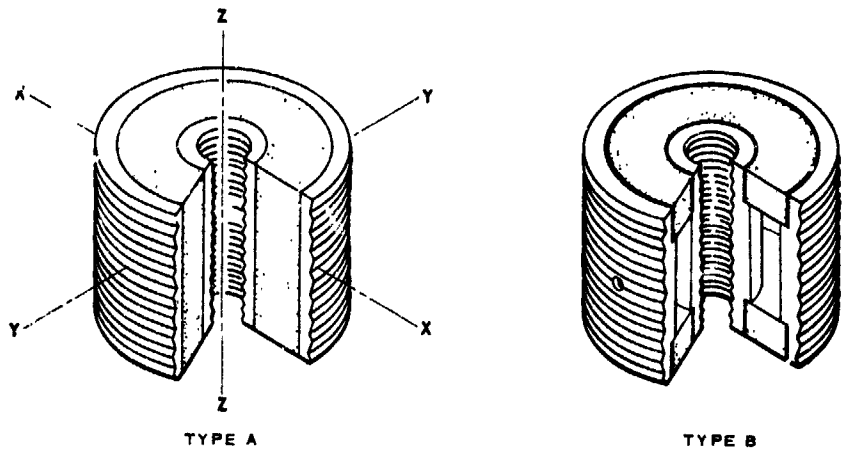

Figure 2. Receiver Implant with Carbon Collar and Plastic Cap
(with Centimetric Scale)



Figure 3. Leg Stump with Implant



○ TYPE "A" FULL ELASTOMER
 △ TYPE "B" PARTIAL

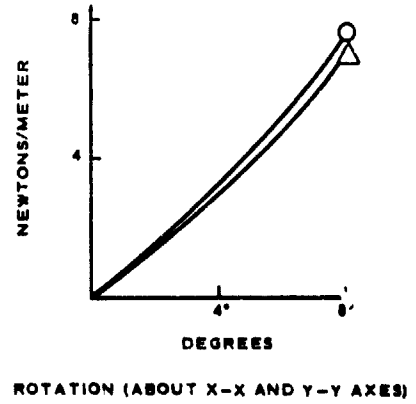
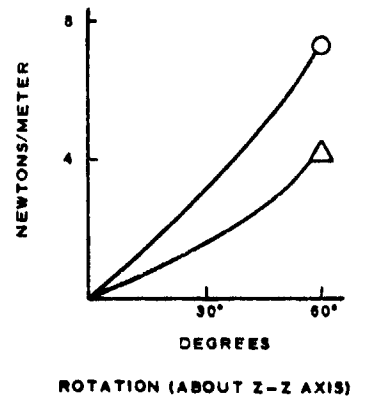
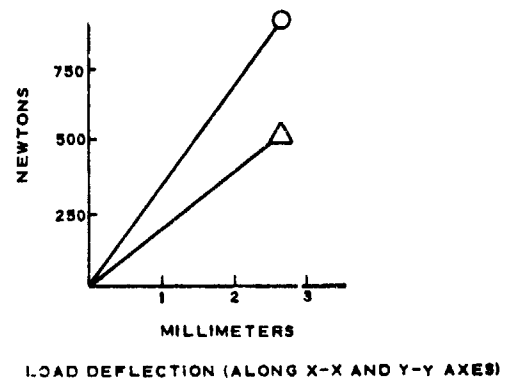
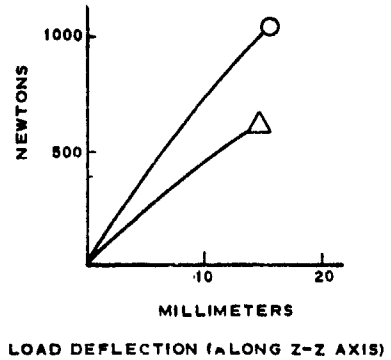

Figure 4. Shock Mount Design Characteristics

View A of Figure 4 shows the shock mount with full elastomer content while View B shows it partially filled, with elastomer only at the ends. The accompanying graphs give load-deflection and torque characteristics for both conditions shown. The amount of elastomer used may be adjusted to produce design variations as required for individual applications. For heavy, active individuals, even larger mounts may be required.

Metal and nylon parts for the shock isolator were fabricated by the Development Testing Branch and the elastomer was processed by the Materials Testing Branch of the Laboratory Division of NASA's KSC Support Operations Directorate. Avibank Manufacturing, Inc., contributed the ball-lock head design. Figure 5 shows the ball-lock pin and shock mount along with a matching receiver and mounting accessories.

Remaining design details were completed with the results shown in the pictorial and detailed views of the below-knee attachment (Figures 6 and 7 respectively). The molded plastic stump socket, designed by hospital staff members and made from a cast of the actual stump, assures custom-fitting and maximum support. It is designed to impart natural feeling by assisting the wearer in sensing minute pressure variations. Tension adjustments on the KSC-engineered portion also contribute toward this end, and to patient comfort, by allowing adjustment of the ratio of load carried by the socket and the connection.

Overall comfort and safety were carefully considered in the design to achieve an integration of components with a progressive failure scheme providing maximum protection to the amputee and the surgical implant.

The yoke-shaped support column of the prosthesis is one of the design variables. Most leg prostheses would require this feature for structural strength, whereas artificial arms hopefully would derive most of their strength from the structural properties of the prosthesis proper. In general, however, the conceptual design developed for the initial quick-disconnect limb would be usable.

Exact design, including cosmetic treatment and dimensioning, would necessarily follow consideration of various characteristics of the individual amputee, including age, sex, build, and degree of activity. The modularity of the basic design would provide for ease of changes and adjustments necessitated by such factors as growth, weight changes, and activity changes in the individual user. Figure 8 shows an attached prosthesis.

CONCLUDING REMARKS

It is the writer's privilege to report completion of the first phase of the quick-disconnect prosthetic design project with the shipment of the leg mechanism in late June, 1974. While it is still too early to assess the impact of this development on the prosthetic state of the art, the hope is great and the hospital reports are enthusiastic. The designers would like to feel that their work, with a major boost from the technology development to help man walk on the moon, is destined to help many more walk, and perform, on earth.

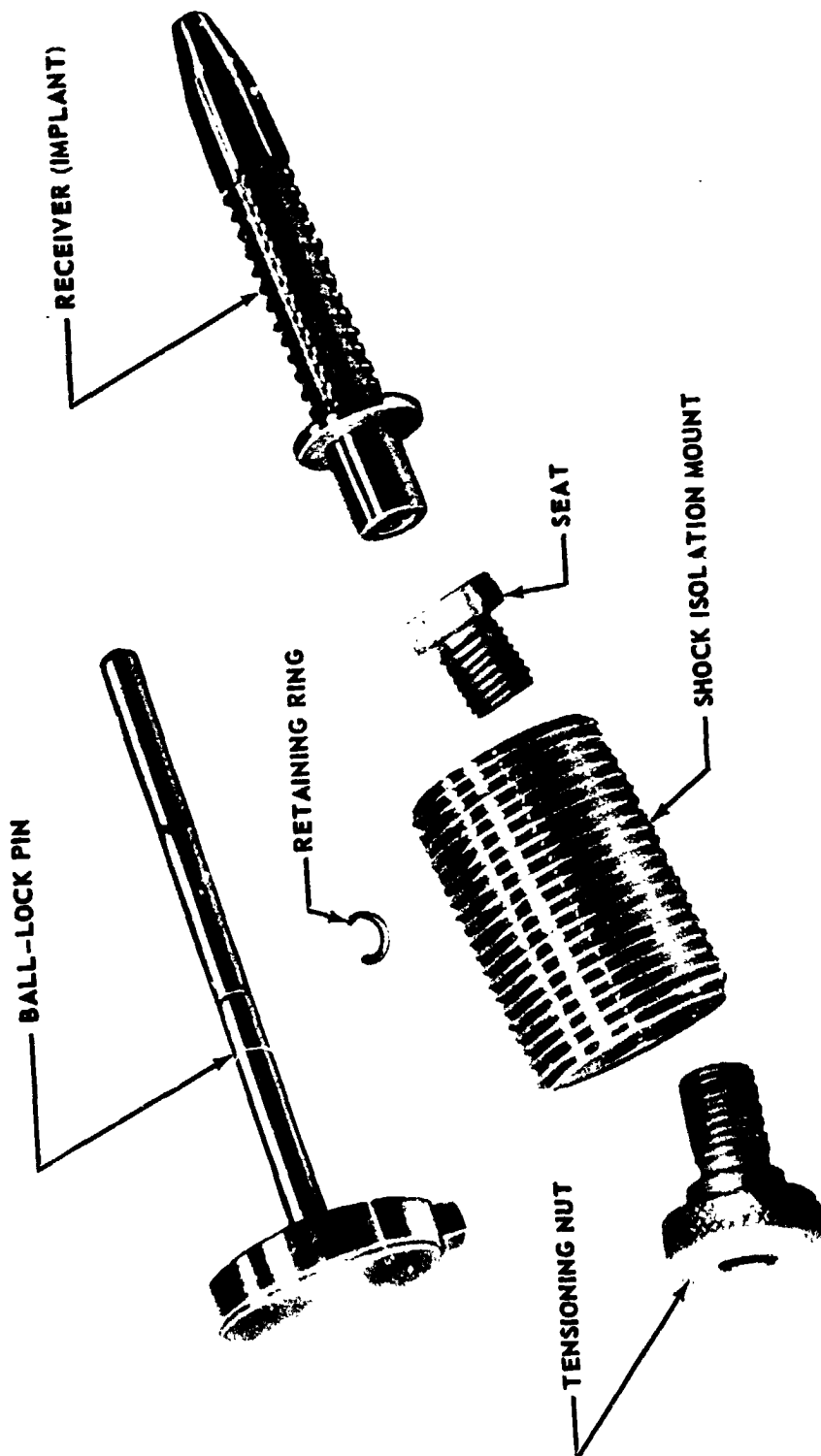

Figure 5. Prosthetic Connector and Shock Mount Components

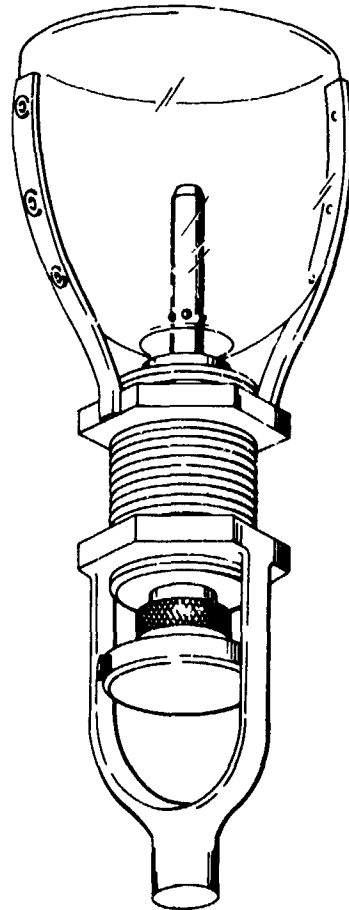
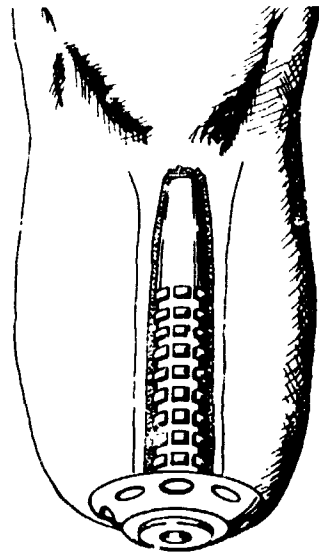

Figure 6. Below the Knee Prosthetic Attachment (Pictorial View)

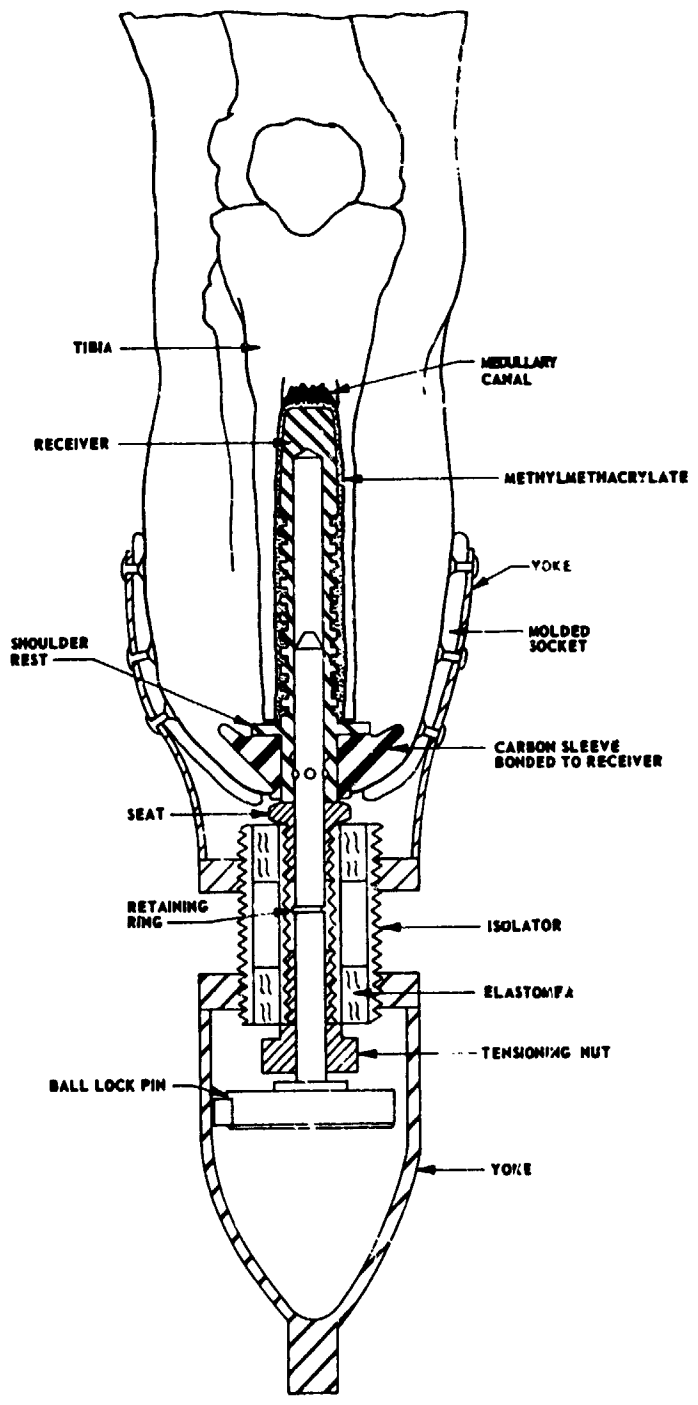

Figure 7. Below the Knee Prosthetic Attachment (Detail View)

ORIGINAL PAGE IS
OF POOR QUALITY

0
C
C

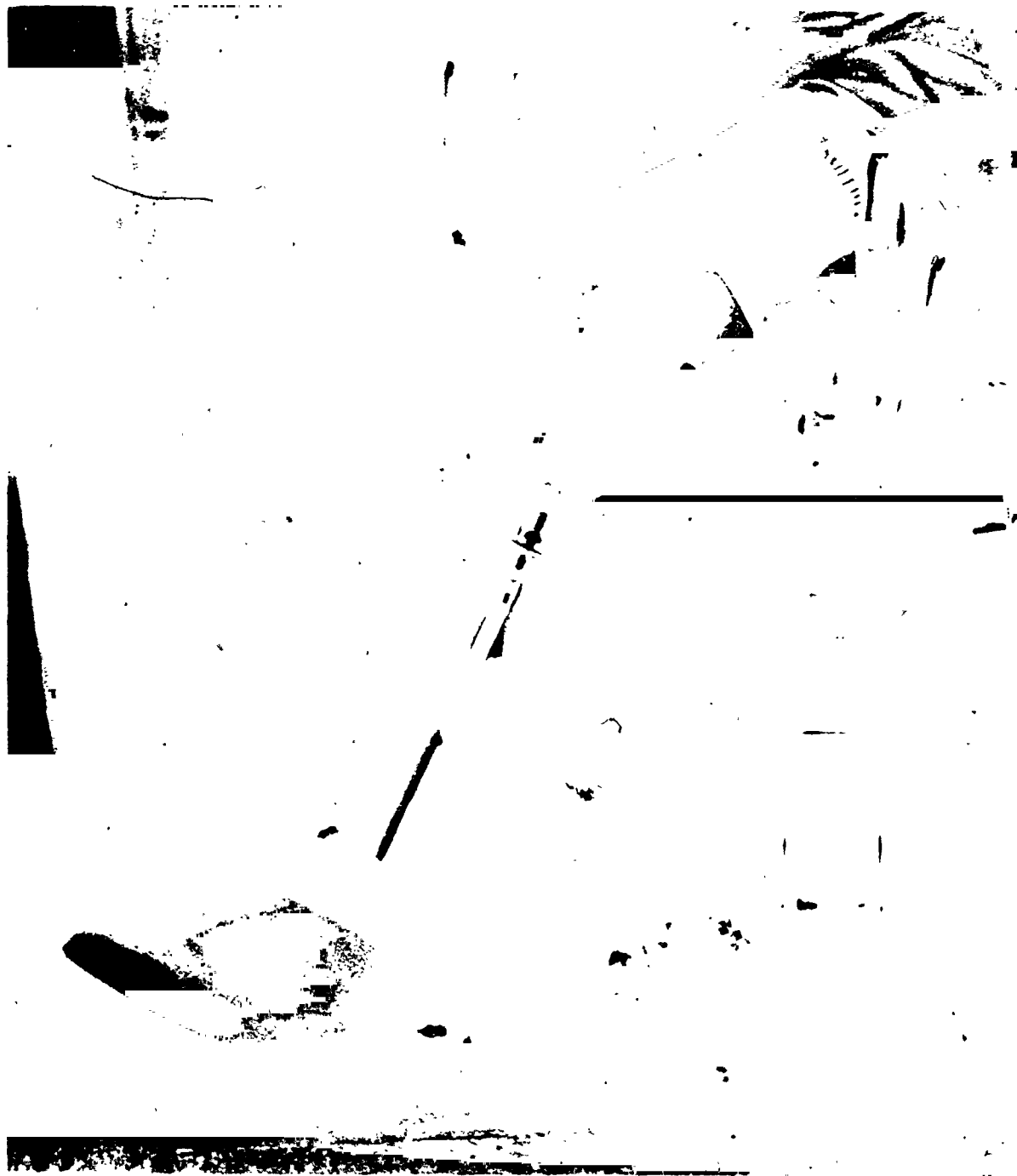

Figure 8. First User

ORIGINAL PAGE IS
OF POOR QUALITY

CREDITS

The success of the design effort must be credited to the efforts and contributions of several individuals, including Drs. Hartmann and Mooney, already mentioned. Others who contributed significantly were Dr. Michael Raklewicz, who performed the first KSC implant, and Dr. James Reswick, Director of the Rehabilitation Engineering Center, both of Rancho Los Amigos Hospital; John Duran, Avibank Manufacturing, Inc.; Jack Bokros, Ph.D., Medical Device Division, Gulf General Atomic Corporation; James Harrell, Miles Hollingsworth, Charles Bright, Frank Markley, William Jones, Glenn Roberts, and Otto Fedor, all of Kennedy Space Center; members of the Logistics Section of the KSC Systems Engineering Division; and Walter Parsons and Donald Buchanan of KSC Design Engineering management. Thanks must also go to Larry McGrath of Planning Research Corporation for assistance in preparing this paper.