

General Disclaimer

One or more of the Following Statements may affect this Document

- This document has been reproduced from the best copy furnished by the organizational source. It is being released in the interest of making available as much information as possible.
- This document may contain data, which exceeds the sheet parameters. It was furnished in this condition by the organizational source and is the best copy available.
- This document may contain tone-on-tone or color graphs, charts and/or pictures, which have been reproduced in black and white.
- This document is paginated as submitted by the original source.
- Portions of this document are not fully legible due to the historical nature of some of the material. However, it is the best reproduction available from the original submission.

A New Wind Energy Conversion System

by

Frederick O. Smetana

November 1, 1975

(NASA-CF-146539) A NEW WIND ENERGY
CONVERSION SYSTEM (North Carolina State
Univ.) 16 p HC \$3.50 CSCL 10A

N76-20629

g3/44 Unclas
15102



Department of Mechanical and Aerospace Engineering
North Carolina State University
Raleigh, N. C. 27607

A New Wind Energy Conversion System

Frederick O. Smetana

Department of Mechanical and Aerospace Engineering
North Carolina State University
Raleigh, N.C. 27607

November 1, 1975

A NEW WIND ENERGY EXTRACTION SYSTEM

DESIGN RATIONALE

Although the fact cannot readily be established by analysis, it seems probable that under some circumstances vertical axis wind energy machines will be superior to horizontal axis machines on a power output/cost basis. At the same time, it is desirable to evolve a design whose output can be easily changed in a modular fashion to meet a variety of wind and load conditions.

Examination of data on existing vertical axis designs indicates that the Darrieus rotor is (a) non-self starting

(b) sensitive to airfoil shape and surface condition

(c) subject to vibrational imbalance because of high rotational speed.

The latter two items lead one to reject this approach for low-cost construction by semi-skilled craftsmen.

The Savonius design, on the other hand, overcomes all these objections. It has, however, a relatively low aerodynamic efficiency and is difficult to design analytically. In studying the basic problem of drag-type vertical-axis wind machines, such as the Savonius design, it is easy to show that "three-dimensional shapes" produce more drag per unit frontal area than do "two-dimensional systems." An example will be presented later to illustrate this concept. It suggests that a cup anemometer will be more efficient aerodynamically than the Savonius Rotor. A study of the experimental results for the front-to-back drag ratio of three-dimensional shapes (Figure 1) indicates that while a hemispherical shell has a front-to-back drag ratio of about 1.38-to-0.38 or 3.63, a narrow angle cone can yield a ratio of 1.41-to-0.2 or about 7.0. Even when one considers the increase in surface area (which is related to fabrication cost) it appears that conical cones are the most aerodynamically efficient shapes per unit surface area one can use

in drag-type vertical axis wind energy conversion systems. In addition the number of cones per pole are easily increased or decreased to match the power requirements of the load.

ESTIMATE OF POWER OUTPUT

An isolated body exposed to a uniform wind experiences a force given by

$$F = C_D \frac{1}{2} \rho S V^2 \quad (1)$$

where C_D is the drag coefficient, ρ the mass density of the air, S the frontal area of the body normal to the wind direction, and V is the wind velocity. If one neglects the interference effects of the support arms, the pole, and the wakes of previous traverses, then the stall torque produced by a pair of cones aligned with the stream is

$$(C_{D_1} \frac{1}{2} \rho S V^2) \ell - (C_{D_2} \frac{1}{2} \rho S V^2) \ell = T \quad (2)$$

where ℓ is the distance from the center of the pole to the center of the cone. C_{D_1} is the drag coefficient of the retreating cone and C_{D_2} is the drag coefficient of the advancing cone.

If the cones are in the same position but now moving and if one neglects centrifugal force effects and the inertia of the air mass, the instantaneous torque is given by

$$[C_{D_1} (V - \ell\omega)^2 - C_{D_2} (V + \ell\omega)^2] \frac{1}{2} \rho \frac{\pi D^2}{4} \ell = T \quad (3)$$

where ω is the angular velocity of the torque arm. Expanding (3) one has

$$\left[(C_{D_1} - C_{D_2}) \left(1 + \frac{\ell^2 \omega^2}{V^2} \right) - 2(C_{D_1} + C_{D_2}) \frac{\ell \omega}{V} \right] \frac{\pi \rho}{8} D^2 V^2 \ell = T \quad (4)$$

Note that in (4) D represents the diameter of each drag body.

The instantaneous power output at this orientation of the rotating cones is thus

$$P = T\omega = \frac{\pi\rho}{8} D^2 V^3 \left[\frac{\ell\omega}{V} (C_{D_1} - C_{D_2}) \left(1 + \frac{\ell^2\omega^2}{V^2}\right) - 2\frac{\ell^2\omega^2}{V^2} (C_{D_1} + C_{D_2}) \right] \quad (5)$$

To find the maximum power output, one solves for ω from $\frac{dP}{d\omega} = 0$ and substitutes into (5):

$$\frac{dP}{d\omega} = \frac{\pi\rho}{8} D^2 V^3 \left[(C_{D_1} - C_{D_2}) \left(\frac{\ell}{V} + 3\frac{\ell^3}{V^3} \omega^2 \right) - 4\frac{\ell^2}{V^2} \omega (C_{D_1} + C_{D_2}) \right]$$

or

$$1 + 3\frac{\ell^2\omega^2}{V^2} - 4\frac{\ell\omega}{V} \left[\frac{C_{D_1} + C_{D_2}}{C_{D_1} - C_{D_2}} \right] = 0,$$

from which

$$\omega_{mp} = \frac{4\ell}{V} \left[\frac{C_{D_1} + C_{D_2}}{C_{D_1} - C_{D_2}} \right] \frac{V^2}{6\ell^2} + \frac{V^2}{6\ell^2} \left[\frac{16\ell^2}{V^2} \left(\frac{C_{D_1} + C_{D_2}}{C_{D_1} - C_{D_2}} \right)^2 - 12\frac{\ell^2}{V^2} \right]^{1/2}$$

or

$$\frac{\ell\omega_{mp}}{V} = \frac{2}{3} \left\{ \frac{C_{D_1} + C_{D_2}}{C_{D_1} - C_{D_2}} - \left[\left(\frac{C_{D_1} + C_{D_2}}{C_{D_1} - C_{D_2}} \right)^2 - \frac{3}{4} \right]^{1/2} \right\} \quad (6)$$

$$\begin{aligned} \therefore P_{max} &= \frac{\pi\rho}{8} D^2 V^3 \left[(C_{D_1} - C_{D_2}) \left\{ \left(\frac{C_{D_1} + C_{D_2}}{C_{D_1} - C_{D_2}} \right) - \left[\left(\frac{C_{D_1} + C_{D_2}}{C_{D_1} - C_{D_2}} \right)^2 - \frac{3}{4} \right]^{1/2} \right\} \right. \\ &\quad \left. + \frac{8}{27} (C_{D_1} - C_{D_2}) \left\{ \left(\frac{C_{D_1} + C_{D_2}}{C_{D_1} - C_{D_2}} \right) - \left[\left(\frac{C_{D_1} + C_{D_2}}{C_{D_1} - C_{D_2}} \right)^2 - \frac{3}{4} \right]^{1/2} \right\}^3 \right. \\ &\quad \left. - \frac{8}{9} (C_{D_1} + C_{D_2}) \left\{ \left(\frac{C_{D_1} + C_{D_2}}{C_{D_1} - C_{D_2}} \right) - \left[\left(\frac{C_{D_1} + C_{D_2}}{C_{D_1} - C_{D_2}} \right)^2 - \frac{3}{4} \right]^{1/2} \right\}^2 \right] \quad (7) \end{aligned}$$

With $C_{D_1} = 1.6$ and $C_{D_2} = 0.3$, for example, P_{max} becomes

$$P_{max} = (0.1187375) \frac{\rho\pi}{8} D^2 V^3 \quad (8)$$

and

$$\omega_{mp} = 0.189475 \frac{V}{\ell} \quad (9)$$

Maximum possible power for this type of device is obtained when $C_{D_2} = 0$. Under those conditions

$$\omega_{mp} = 0.333 \frac{V}{\ell}$$

and

$$P_{max} = 1.4(0.37) - 2.8(0.1111) \frac{\pi \rho}{8} D^2 V^3 = (0.207) \frac{\pi \rho}{8} D^2 V^3;$$

thus, the cones chosen for the example yield about 57.5% of the maximum possible power.

The maximum rotational speed of the device occurs when the output torque is zero. From equation (3) one can show that the free running angular speed is

$$\omega = \frac{V}{\ell} \frac{\frac{C_{D_1}}{C_{D_2}} - 1}{\frac{C_{D_1}}{C_{D_2}} + 1} \quad (10)$$

Since cones oriented 90° to the wind probably develop little or no torque, one would expect that instantaneous power output can be represented by

$$P = 1/2 P_{max} \cos^2 \phi + 1/2 P_{max}$$

where ϕ is the angular displacement of one cone from its initial position aligned with the stream. The average power developed for the cones in this example is thus

$$\int_0^\pi P \, d\phi = P_{av} = \frac{\sqrt{2}}{2} P_{max}$$

or

$$0.08413 \frac{\pi \rho}{8} D^2 V^3 \quad (11)$$

In order to obtain an indication of how such a system might compare with a Savonius design, one can determine the power provided by two isolated hemicylinders attached to the central pole along their ends. In this case $C_{D_1} = 2.3$ and $C_{D_2} = 1.2$. See Figure 1. Then, according to equation (7)

$$P_{\max} = 0.0438 \frac{\rho V^3}{2} Dh \quad (12)$$

and

$$P_{\text{av}} = 0.031 \frac{\rho V^3}{2} Dh \quad (13)$$

While this is not the optimum placement of the hemicylinders, it does indicate that the cones are more than twice as efficient aerodynamically for the same frontal area. Even for the same surface area, the cones are still about twice as efficient. (For equal frontal area, the cones ($h = 4r$) have 1.315 times the surface area.)

Table I shows the results of a small-scale wind tunnel test for two pairs of cones. Note that the measured power output is 86% of the theoretical prediction for a cone half-angle of about 15° .

COMPARISON WITH HORIZONTAL AXIS SYSTEMS

Ideally a propeller on an axis aligned with the wind can extract about 57% of the energy in a tube of air whose diameter is equal to propeller span. This is 2.75 times as much as the amount of energy extracted by an ideal cone device from the same stream. The reason for this lies in the way momentum is withdrawn from the stream.

If one could take all of the momentum from a stream tube of air the power would be given by

$$P = \frac{\pi \rho D^2 V^3}{8} \quad (14)$$

But if all the momentum is removed from the air at the propeller face the air would have no further velocity and would accumulate at the propeller. Thus, if the air is to proceed downstream from the propeller it cannot lose all its momentum and the power developed by the propeller is therefore less than that given by (14). In fact, propeller theory shows that only about 57% of this momentum is recoverable with such a device.

Now examine the situation for drag devices. At the rotational speed for maximum power, the torque produced by a cone pair is only 46% of its stall torque. This is because one cone is retreating before the wind and not producing as much energy while the other is advancing into it and absorbing more power. To recover all the energy from the stream tube the retreating cone would have to develop stall torque yet move at the wind speed. It could do this only if the air were to freeze and adhere after striking the surface. Since this is unlikely, one must allow the air striking the surface to leave and carry with it some momentum.

The propeller devices are more efficient per unit frontal area because they utilize the force absorbed from the air striking the blade surface to turn the blades and thereby pull more of the air from the oncoming stream tube through the disc where it can react with the blades. In the drag devices the air spills around the drag surface. As a result, a majority of the oncoming streamtube is deflected and never encounters the drag surface directly. In addition, the average torque developed by the drag devices is only 70% of its peak torque while the propeller devices develop constant torque as long as they are aligned with the stream. (This is not true for Darrieus rotors where the torque also varies cyclically.)

In return for this higher efficiency (about a factor of 3 to 3.5 for real designs) and better speed matching to common loads, the rotational

stresses experienced by propeller-type devices are some 900-1600 times as great. The blade shape and its surface finish also have rather strong influences on efficiency. As little as a 6° change in wind inclination can cause a noticeable loss of output. If the propeller axis is made moveable to take advantage of the full wind force, the generator or compressor which converts the wind energy must be mounted on bearings to rotate with the wind direction and the power or compressed air taken off with slip rings or swivel fittings. The large mass associated with such apparatus means a very large tail is required if the system is to follow changes in the wind direction rapidly. Hence, it is likely that such systems will be more expensive per unit power output despite their greater aerodynamic efficiency.

OTHER AERODYNAMIC CONSIDERATIONS

A problem which must be faced in any large scale aerodynamic device is the effect of unsteady flow. Such flow inflicts vibratory loads of large magnitude on the structure. The failure of the large windmill at Grandpa's Knob after only a few months of service for example was due to a fatigue failure induced by such loads. Blunt bodies are particularly subject to large loads because of the periodic separation of vortices at certain Reynolds numbers. It is important to investigate this problem since external vortex shedding does not always scale linearly with Reynolds number. Further, wind tunnel test models tend to be a good deal stiffer than full-scale hardware. In addition, internal vortex resonances in the retreating body depend only on body size, not Reynolds number. All these phenomena couple and can lead to very serious dynamic stresses.

It is fortunate that an inverted conical shell is an acoustically non-resonant device. (A hemispherical shell however is resonant to asymmetric

vortex shedding from the lip. Such shedding can produce very large lateral forces. This is the reason parachutes must be vented to keep their descent paths straight). As a result, one must contend principally with the smaller forces of the vortex shedding into the wake of the advancing cone. In addition to this effect, each cone is flying in turbulent flow and experiences some aeroelastic effects.

Because of the possibility of introducing resonant cavities into an otherwise non-resonant conical shell one must be careful in providing internal stiffening. Further, the lip of the shell should remain sharp to promote maximum air capture and widest possible spillage, in other words, to promote maximum drag. The advancing cone should be as smooth and sharp as possible to minimize skin friction and the generation of unwanted vortex lift.

OPERATIONAL CONSIDERATIONS

Equation (6) shows that for a given wind speed the rotational velocity of the vertical axis drag device depends inversely upon the distance of the cone center from the main shaft. Wind tunnel tests indicate that for high aerodynamic effectiveness, the minimum separation of the cone edge from the main shaft is about one cone diameter. Thus, large wind energy conversion systems of this design must of necessity turn at low angular velocities. Typically, a device with two 5' diameter cones 10' long mounted with their centers 7.5' from the main shaft will turn at 7.068 rpm in a 20 mph wind while generating 0.0902 hp. Stall torque under these wind conditions is 482 ft-lbs. A device consisting of 4 non-interacting cone pairs on the same shaft should develop about 0.36 hp in a 20 mph wind. Such a device is shown in Figure 2. Note that the cone arms are designed to assist the cones in developing torque. Note also that for operational use the entire

system should be placed further above the ground.

The low angular velocity developed by full-scale devices means that slight mass imbalances will not cause significant vibrational problems. On the other hand, the low angular velocities mean that a transmission providing a significant speedup is required to drive most mechanical devices designed with an electric motor or gas engine drive in mind. There is the further problem that most devices one might wish to use as a load have linear speed-power requirements whereas the windmill power output varies as wind velocity to the third power. If the driven device is an air compressor, the power absorbed can be modulated by altering the discharge pressure and flow rate delivered once a minimum operating speed has been achieved. Thus, as the wind speed increases, the compressor can be made to bypass less air as a means of absorbing more power than would be absorbed by just increasing its speed.

Air compressors, unlike electric generators, have high starting torque requirements. Their torque required however falls off drastically once they are running and then depends almost entirely on effective discharge pressure. Thus, to match the compressor to the wind machine output, it is necessary to design the transmission to provide sufficient torque at 6 to 8 mph to start the compressor. One must then regulate the outlet-to-inlet air bypass so as to keep the linear speed of the cone centerline at least 0.2 to 0.3 times the wind speed and below any critical compressor speed, generally about 900 rpm for the smaller size compressors.

The reasons for choosing to store wind energy as compressed air are

- (1) The efficiency of compression can usually be on the order of 0.85 or more which is fairly high compared to the conversion of mechanical energy to electrical energy in a storage battery.

(2) The release of stored energy through an air motor can also be effected at high efficiencies, 0.85 or better.

(3) Design, construction, and maintenance of an all-mechanical system is usually simpler than those for a system involving mechanical to electrical conversions.

Note: Data in Figure 1 are replotted from S. Hoerner, Fluid Dynamic Drag, Published by the author 1959.

TABLE I
WIND TUNNEL TEST RESULTS

Conical Cone Wind Energy Conversion System

3" Arm length

4 - 3" diameter cones in two planes

20 mph wind speed

RPM	TORQUE $\times 10^3$	HORSEPOWER $\times 10^4$
0	21.22	0
100	15.44	2.94
110	14.28	2.99
149	13.51	3.83
160	12.73	3.87
175	11.58	3.74
180	10.80	3.70
205	8.88	3.46
220	7.72	2.82
245	5.79	2.70
300	0	0

Theoretical Predictions: Maximum power 4.49×10^{-4} H.P.
No load speed 295 RPM
Speed for max power 141.37 RPM
Stall torque 24.43×10^{-3} ft-lbs

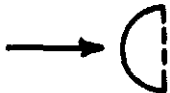






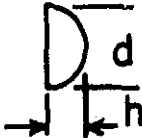
SHAPE	C_D
(2 - DIMENSIONAL)	
	1.20
	1.98
	2.30
	2.20
	1.17
(3 - DIMENSIONAL)	
	0.38 ~ 0.42
	1.17
	$\frac{h}{d} = 0.3$ 1.35 $= 0.4$ 1.38 $= 0.5$ 1.42 $= 1.5$ 1.0

FIG 1A

PRECEDING PAGE BLANK NOT FILMED

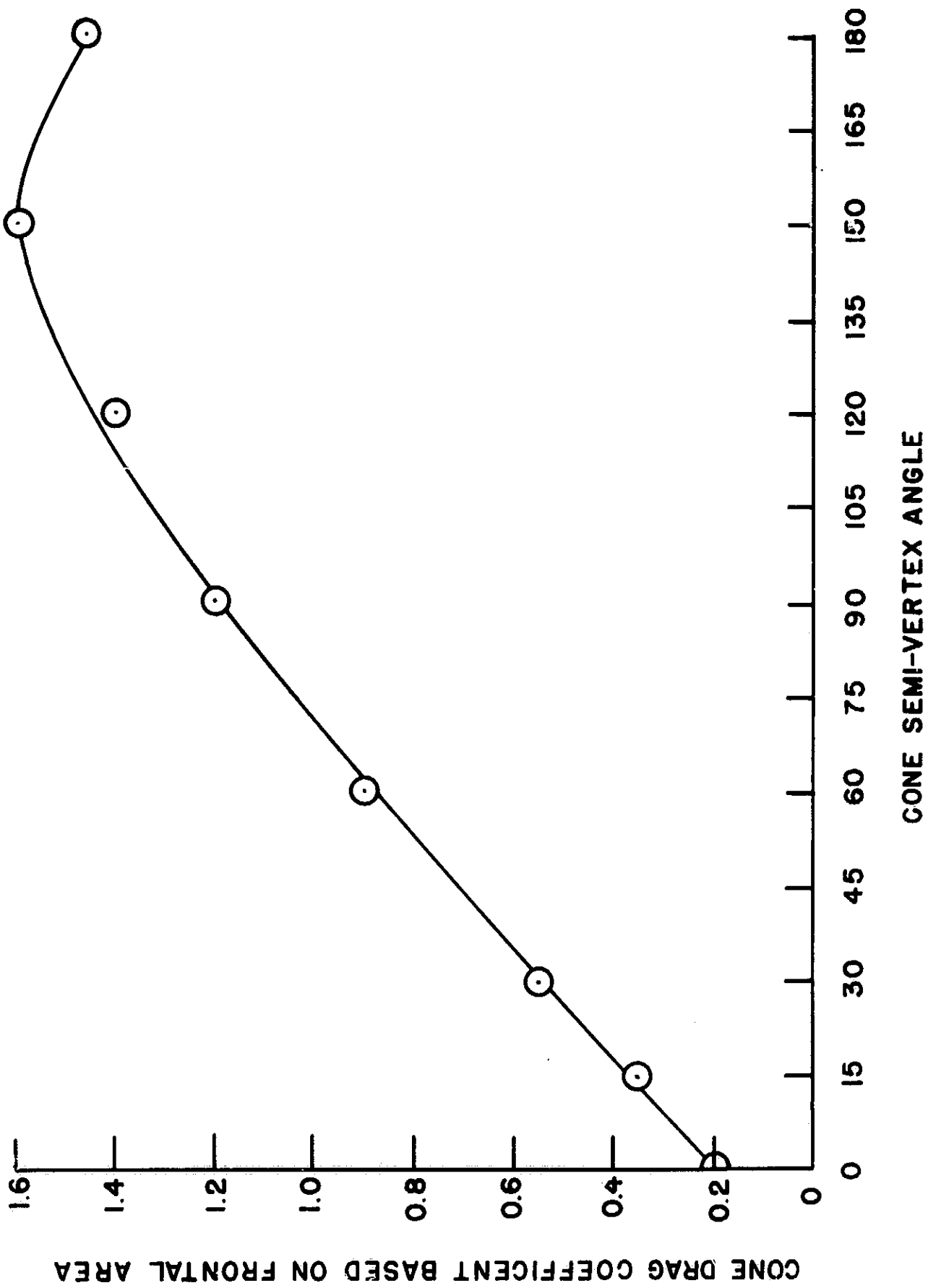
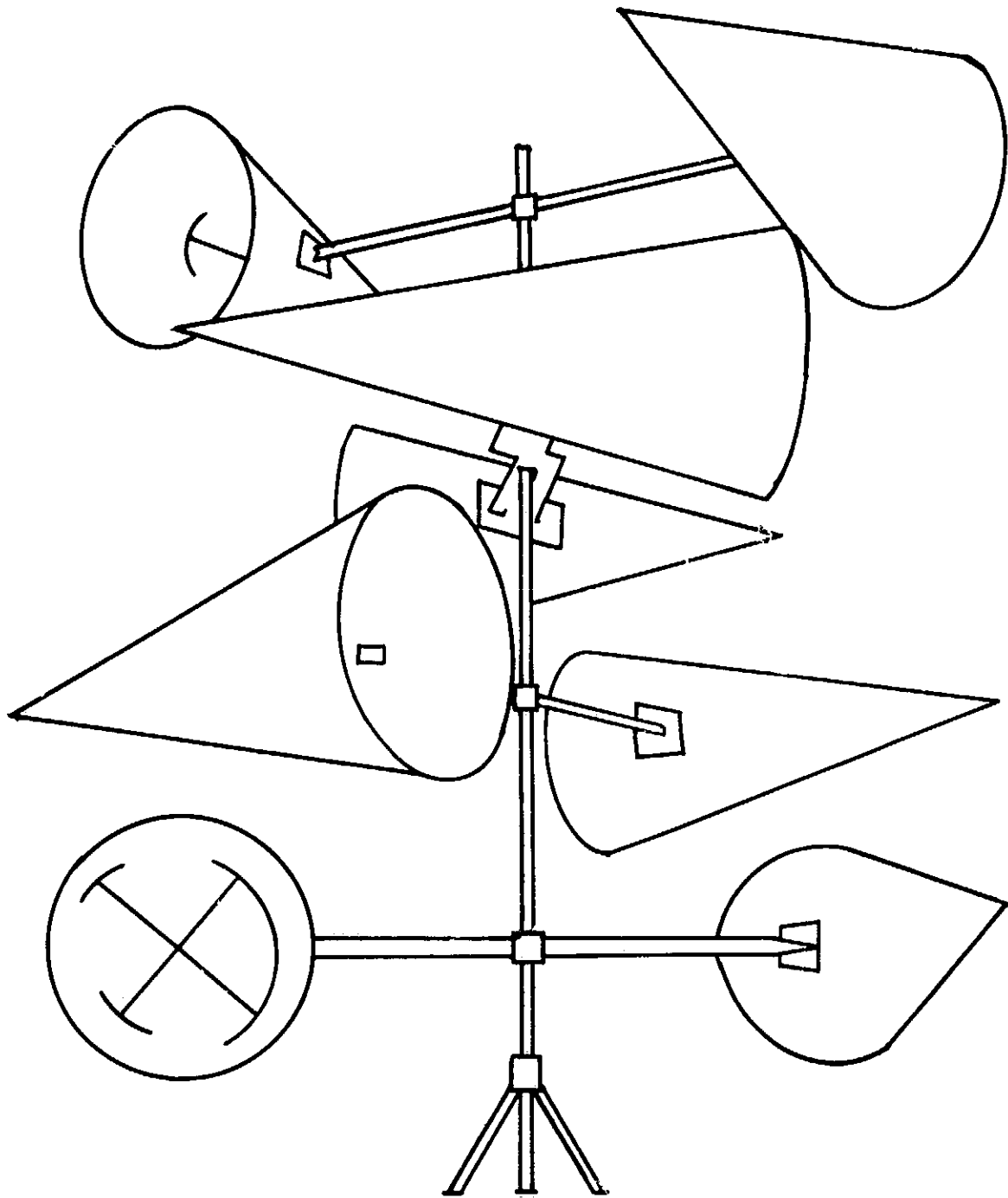


FIG 1B



**NCSU WIND ENERGY
SYSTEM**

FIG 2