

HYDROGEN-FUELED SCRAMJETS;
POTENTIAL FOR DETAILED COMBUSTOR ANALYSIS

H. L. Beach, Jr.
NASA Langley Research Center

SUMMARY

Combustion research related to hypersonic scramjet (supersonic combustion ramjet) propulsion is discussed from the analytical point of view. Because the fuel is gaseous hydrogen, mixing is single-phase and the chemical kinetics are well-known; therefore, the potential for analysis is good relative to hydrocarbon-fueled engines. Recent progress in applying two- and three-dimensional analytical techniques to mixing and reacting flows indicates cause for optimism, and identifies several areas for continuing effort.

INTRODUCTION

Research in hypersonics, while lying dormant for the last 8 to 10 years throughout much of the R&D community, has been proceeding at a quite viable pace at NASA Langley. There have been technology advancements in a number of areas, including propulsion. The realities that have driven the new concepts for hypersonic engines are the need for hydrogen fuel (for performance and cooling), the need for supersonic combustion (to reduce internal pressure, gas dissociation, and heat flux), and the necessity to very closely integrate the propulsion system with the aircraft. For example, at Mach 10 almost all of the airflow between the underside of the vehicle and its bow shock must be utilized in the propulsion cycle, and this implies an inlet capture shaped much like the vehicle undersurface as shown in figure 1. By dividing this area into smaller units, the propulsion system becomes a set of modules whose size and shape are appropriate for test in a ground facility. With this arrangement, the entire vehicle undersurface is an integral part of the engine; the forebody pre-compresses the flow coming into the inlet, and the afterbody serves a major function of the nozzle. Installation losses, which are extremely severe for pod-type engines, can easily be minimized by shaping of the lower surface or cowl.

Complete descriptions of engine module design philosophy, performance, and status are discussed in references 1 to 3. Summarizing briefly with the aid of figure 1, the module is highly three-dimensional, has a rectangular capture area and employs fixed geometry. The inlet process is completed by the side-walls and three struts which are swept to the oncoming flow and span the vertical dimension of the module. The sweep, coupled with a cutback cowl, causes spillage which allows starting of the inlet at low flight Mach numbers. In addition to being part of the inlet, the struts are the fuel injectors.

Multiple fuel injection planes provided by the struts make the combustor shorter; this, combined with a diverging combustor area, gives good performance with lower internal pressure and cooling requirements than a constant-area combustor with wall injection.

The combustor flow field can be regarded, at least for high Mach number flight, as mixing controlled. Advantage is taken of the differences between the mixing characteristics of parallel and perpendicular fuel injection to control the heat release over a wide speed range. Understanding and predicting mixing in the presence of turbulence and reaction are prime areas for research because they are real keys to effective engine operation. Other influences which must be addressed include streamwise and transverse pressure gradient, shock and expansion waves, injection disturbances, external (such as acoustic) disturbances, and three-dimensional interactions. While these make a formidable list for a potential combustor analyst, there are several inherent advantages which lead to optimism. First, the combustor geometry is relatively simple downstream of the struts (plane walls, no flame holders). Second, the hydrogen fuel is injected as a gas, and the flow is single-phase. Third, hydrogen-air combustion kinetics are very well-known compared to conventional hydrocarbon fuels.

The purpose of this paper is to discuss areas of research directed toward combustor analysis and design currently being pursued in and out of house in the Langley hypersonic propulsion program. (See reference 4 for a discussion of earlier work).

SYMBOLS

D_j	injector diameter
P_T	pitot pressure
R	radial distance measured from flow centerline
T	static temperature
U	streamwise velocity
X	streamwise direction
Y, Z	transverse directions defined in figure 6
α_i	species mass fraction
v_i	species mole fraction

Subscripts:

c	centerline
o	at $x = 0$

COMBUSTOR ANALYSIS DEVELOPMENT

Combustion-related research in hypersonic propulsion is divided into the general areas of basic research, which covers fundamental problems relevant to any combustor concept, and combustor development. Both areas have experimental and theoretical aspects. Due to facility requirements, most experimental work has been done in-house, while many analytical developments have been accomplished out of house.

Basic Research

Significant effort has been devoted to the analysis of simple-geometry, parabolic, turbulent, mixing/reacting flows. (Descriptions of various approaches by a number of researchers can be found in references 5 and 6). The approach currently being employed in scramjet work at Langley (ref. 7) utilizes boundary-layer-type equations with two differential equations for turbulent kinetic energy and dissipation of turbulent kinetic energy leading to the turbulent viscosity. Fuel and oxidizer concentration fluctuations which allow the modeling of turbulence effects on reaction are also computed. The turbulent reaction model being used for very high-temperature flows is a modification of that described in reference 8, and is based on the rate at which the concentration fluctuations dissipate (eddy breakup) rather than molecular processes (chemical kinetics). However, this model will not be adequate in lower temperature flows or regions of flows where kinetics effects may be competing equally with turbulence effects, and studies are continuing to develop an appropriate model including both. At any rate, it is clear that the reaction model can be extremely important in describing the details of a reacting flow. For example, the degree of reaction is coupled directly to the local temperature, indirectly to the pressure, and through both of these (and composition) to the density. Not only will errors arise in these variables from an inadequate reaction model, but also in more qualitative parameters such as the "spread" of the mixing zone.

Two alternate approaches are now being investigated which could have substantial impact on the future character of both turbulence and reaction models. The first solves differential equations for the second-order turbulence correlations (second-order closure, ref. 9). This technique is powerful but quite complex and requires the solution of up to thirty partial differential equations. For this reason, its applicability may be restricted to simple geometry. The second approach employs statistical theory to develop distribution functions from which any flow field quantities of interest can be derived (ref. 10). Here again, practical considerations may limit the applicability. Because temperature, velocity, specie concentration and temperature fluctuations are computed in both approaches, however, the potential exists for detailed study and improved understanding of turbulence-mixing-reaction interactions.

Since shocks, expansions, and transverse pressure gradients are inevitable in a supersonic combustion ramjet, the ability to account for them is essential. A combined hyperbolic-parabolic technique has been developed (viscous characteristics, ref. 11) and applied (ref. 12) with some success to an underexpanded hydrogen diffusion flame. This technique computes the shocks explicitly rather

than smearing them. Whether shocks must be explicitly handled in the combustor is not clear at this time, but it is apparent that any characteristics method will need very sophisticated coupling with other techniques when there are adjacent or imbedded regions of subsonic flow.

Other pertinent areas of basic combustion research, such as the use of acoustical disturbances to alter mixing rates and investigation of large-scale turbulence, are in the planning stage. Development of models to describe such flows awaits the generation of appropriate experimental data.

Component Analysis

Combustor component flow fields generally exhibit most of the characteristics studied in basic research; in addition, they are three-dimensional. The goal is therefore to build three-dimensional computation tools that incorporate all of the salient features possible. A beginning in this area has been accomplished with the development of finite-difference (ref. 13) and finite-element (ref. 14) computer codes. These are parabolic codes currently being evaluated by comparisons with pertinent mixing and reacting data. At this time, both have the capability for two-equation turbulence modeling with equilibrium chemistry. Features to be added will depend on the basic research identification of the key issues.

TYPICAL RESULTS

A serious problem in the evaluation of turbulent reacting flow analysis is the lack of appropriate experimental data with which to compare. Nearly always the real unknowns in the analysis are the turbulence quantities, and these are the most difficult to measure. For now, in turbulent flames of interest in supersonic combustion ramjets, the only reliable in-stream measurements are time-averaged pitot and static pressure and gas composition. The potential for time and spatially resolved temperature and species measurement exists through laser-Raman scattering techniques, but their practical application is still some time off. Comparisons are therefore possible only with mean quantities, and the value of a particular turbulence or reaction model must be inferred from the mean flow.

To add to the data base for analysis evaluation, a coaxial, axisymmetric, experimental program was conducted in the Langley combustion test stand. A description of the apparatus is given in reference 12; it consists of a Mach 2 test gas nozzle with an exit diameter of 6.57 cm, and a centerline mounted, 0.95 cm diameter, Mach 2 hydrogen injector. The high-temperature test gas was obtained by burning hydrogen in air and replenishing the volumetric oxygen content; it therefore contained significant water vapor. Test gas total temperature was approximately 2400 K, and injector hydrogen total temperature was 460 K. Measurements consisted of radial pitot pressure profiles at five axial locations and gas samples at four locations.

Centerline data for hydrogen and water mass fractions and pitot pressure are shown in figure 2 along with the theory of reference 7. Initial conditions

for the calculation were derived from measured nozzle-exit profiles; initial turbulence quantities were generated by iterative short-step calculations which allowed the turbulent kinetic energy and dissipation profiles to develop. The composition comparisons are reasonably good, and appear to improve with increasing downstream distance. Pitot pressures do not compare as well; this is very likely due to the assumption in the analysis of uniform static pressure. Computation of pitot pressure is accomplished by use of local Mach number, specific heat ratio, static pressure and the Rayleigh pitot formula; sensitivity to the level of static pressure is therefore large, and even a very weak shock can cause considerable error (particularly on the centerline in axisymmetric flow). Computed composition profiles at the 26.7 diameter station are compared with experimental data in figure 3. Note that the theoretical profile shapes look reasonable, and the reaction model predicts an overlap of hydrogen and oxygen profiles such as that found in the data. However, the curves are displaced radially. It is believed that the displacement is due to a combination of pressure effects and reaction model effects; both of these cause density inaccuracies that distort the computed profiles.

Better agreement with experiment is found in the application of the same theory to the data of reference 15 (figs. 4 and 5). Here again hydrogen is injected coaxially into an airflow, but in this case the flow is very low-speed. Centerline comparisons are quite good, and radially, the degree to which the theory overpredicts the spread of the mixing zone is less than in supersonic flow (fig. 3). It should be noted, however, that the supersonic case covers only the near field where initial conditions, injector geometry, and associated shock and expansion waves may have significant effects on the actual flow that are not accounted for in the theoretical calculation. The collective supersonic and subsonic results indicate that promising progress is definitely being made in analyzing turbulent reacting flows, but also emphasize the need for the on-going work particularly in the treatment of reaction and pressure gradient.

The lack of appropriate experimental data for fundamental theoretical evaluation is even worse for three-dimensional flows. While a multitude of combustor data for a wide variety of geometries and applications are available, the detailed measurements are typically at the combustor exit. Defining initial conditions for a computation is sketchy at best due to the scarcity of measurements in the complex near-injector flow. To help alleviate this problem in the evaluation of three-dimensional combustor analyses, a cold-flow, strut-injection, constant-area, helium-air mixing experiment was conducted. Helium was used in place of hydrogen as a safety measure for cold-flow data acquisition. A schematic of the apparatus is shown in figure 6 (see reference 16 for details). The air nozzle is Mach 2.7, and the strut leading edge has a 6° half-angle. Helium injection took place from five equally spaced fuel injectors dividing the flow region at the strut into nearly square mixing regions. Four of the injectors are 10° conical nozzles (Mach 3.6); the other injector is actually two sonic jets directed toward each other.

Extensive pressure and composition measurements to provide initial conditions for analysis were taken at the 10.2 cm station. Detailed information was again obtained at the duct exit, and computations compared with these data. Figure 7 shows typical comparisons of velocity, temperature, and helium concentration in three vertical lines at the duct exit. The theoretical curves represent

the theory of reference 13, with the same type of two-equation turbulence model used in the 2-D theory. Agreement between data and theory is quite encouraging for all three variables. It should be noted that advantage was taken in the computation of symmetry planes along the center of the duct ($Y = Z = 0$) and between jets. Detailed handling of the complete duct in a single computer run is not practical at this time due to computer storage and to run-time constraints. However, the 150 K storage and 250 second run time for the figure 7 computations (on a CDC 6600) are also very encouraging.

Since the quantity of numerical information produced in a typical three-dimensional calculation is enormous, qualitative evaluation of each run is desirable with the aid of contour plots similar to those shown in figure 8. The decay of the central helium jet in figure 6 is depicted in this figure as computed by the finite-element theory of reference 14. Information such as profile spreading, boundary condition checks, and discretization checks can readily be determined from such plots. For example, the continuing sharp peak on the centerline in figure 8 indicates a need for additional elements inside the helium jet.

Application of the three-dimensional codes to hydrogen-air reacting flow in the same apparatus is currently underway. Also, modeling of the very near field is proceeding in order that the upstream data station (currently the initial computation station) can be represented satisfactorily from known conditions at the strut itself. Both semi-empirical global analysis and detailed elliptic analysis are being pursued. Pending successful achievement of these developments, coupled with turbulence and reaction models formulated from basic research, reasonably detailed analysis of scramjet combustors should be possible.

CONCLUDING REMARKS

Scramjet combustor analysis is progressing both in the turbulent mixing/ reaction areas and in the handling of more complex geometries. Recent results have shown very promising agreement between theory and data, and research to further develop the various techniques is continuing. It should be emphasized that computations are generally only as good as their initial conditions, and models of the very near field must be improved if the state of the art is to progress beyond analysis to design. With persistent effort, however, the outlook is good for reasonably detailed prediction of scramjet combustor flow fields within the foreseeable future.

REFERENCES

1. Anderson, G. Y.: Hypersonic Propulsion. Paper XV, NASA SP-381, May 1975.
2. Henry, J. R.; and Beach, H. L.: Hypersonic Airbreathing Propulsion. Paper No. 8, NASA SP-292, Nov. 1971.
3. Henry, J. R.; and Anderson, G. Y.: Design Considerations for the Airframe-Integrated Scramjet. NASA TM X-2895, 1973.

4. Evans, J. S.; and Anderson, G. Y.: Supersonic Mixing and Combustion in Parallel Injection Flow Fields. Presented at AGARD Propulsion and Energetics Panel Meeting (Liege, Belgium), Apr. 1974.
5. Free Turbulent Shear Flows. NASA SP-321, 1973.
6. Murthy, S. N. B., ed: Turbulent Mixing in Nonreactive and Reactive Flows. Plenum Press, 1975.
7. Spalding, D. B.; Launder, B. E.; Morse, A. P.; and Maples, G.: Combustion of Hydrogen-Air Jets in Local Chemical Equilibrium. NASA CR-2407, 1974.
8. Lilley, D. G.: Turbulent Swirling Flame Prediction. AIAA Paper 73-651, July 1973.
9. Donaldson, C. DuP.: On the Modeling of the Scalar Correlations Necessary to Construct a Second-Order Closure Description of Turbulent Reacting Flows. Turbulent Mixing in Nonreactive and Reactive Flows, S. N. B. Murthy, ed, Plenum Press, 1975, pp. 131-162.
10. Chung, P. M.: A Kinetic Theory Approach to Turbulent Chemically Reacting Flows. TR E75-1, College of Engineering, University of Illinois at Chicago Circle, 1975.
11. Dash, S.; and Del Guidice, P.: Analysis of Supersonic Combustion Flow Fields with Embedded Subsonic Regions. (ATL TR 169, Advanced Technology Laboratories; NASA Contract NAS1-10948), NASA CR-112223, 1972.
12. Jenkins, R. V.: Mixing and Combustion of an Underexpanded H₂ Jet in Supersonic Flow. AIAA Paper 76-610, July 1976.
13. Dyer, D. F.; Maples, G.; and Spalding, D. B.: Combustion of Hydrogen Injected into a Supersonic Airstream (A Guide to the HISS Computer Program). NASA CR-2655, 1976.
14. Zelazny, S. W.; Baker, A. J.; and Rushmore, W. L.: Modeling of Three-Dimensional Mixing and Reacting Ducted Flows. NASA CR-2661, 1976.
15. Kent, J. H.; and Bilger, R. W.: Turbulent Diffusion Flames. Fourteenth Symposium (International) on Combustion, The Combustion Institute, pp. 615-625, 1973. (Primary Source - Kent, J. H.; and Bilger, R. W.: Measurements in Turbulent Jet Diffusion Flames. T.N. F-41, University of Sydney, 1972).
16. McClinton, C. R.: Evaluation of Scramjet Combustor Performance Using Cold Nonreactive Mixing Tests. AIAA Paper 76-47, Jan. 1976.

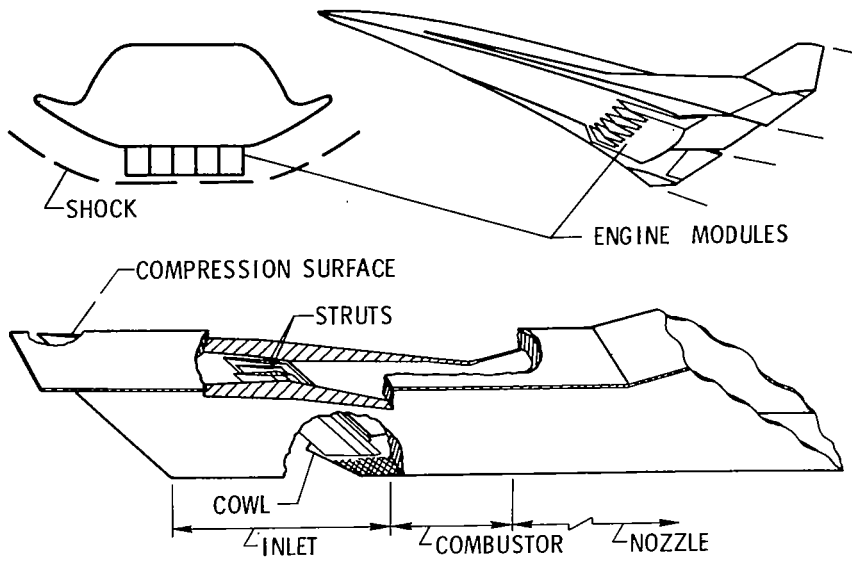

Figure 1.- Scramjet module concept. Fixed geometry from speeds of Mach 3 to 10.

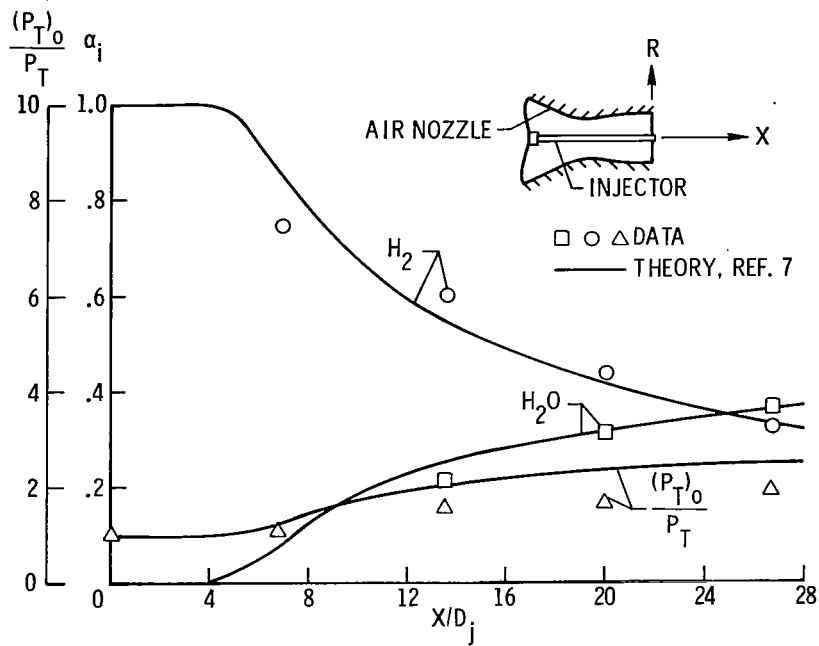

Figure 2.- Comparison of measured and computed centerline properties in supersonic flow.

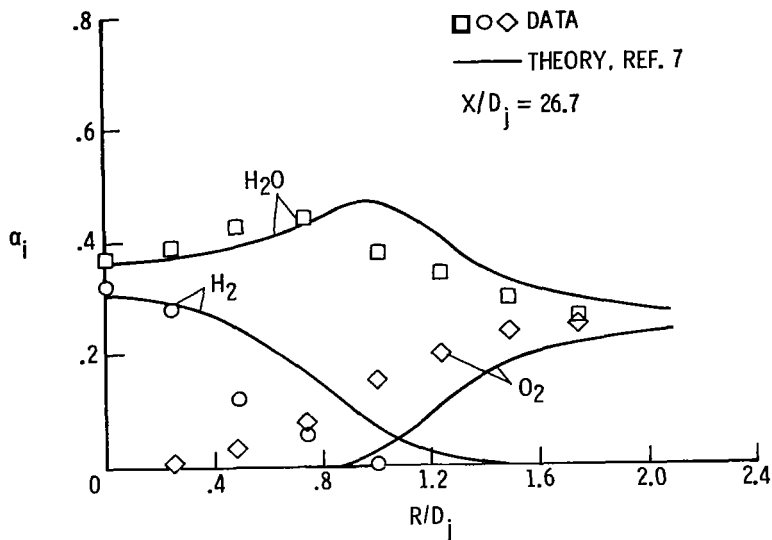

Figure 3.- Comparison of measured and computed radial properties in supersonic reacting flow.

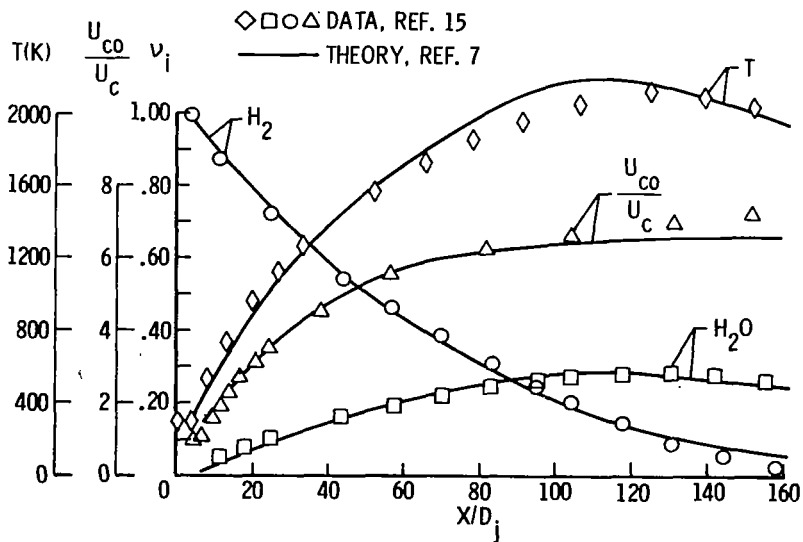

Figure 4.- Comparison of measured and computed centerline properties in subsonic reacting flow.

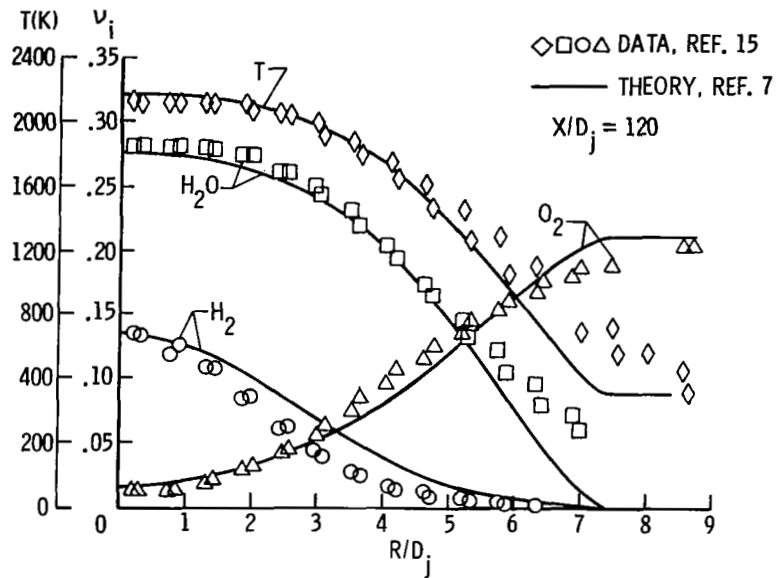

Figure 5.- Comparison of measured and computed radial properties in subsonic reacting flow.

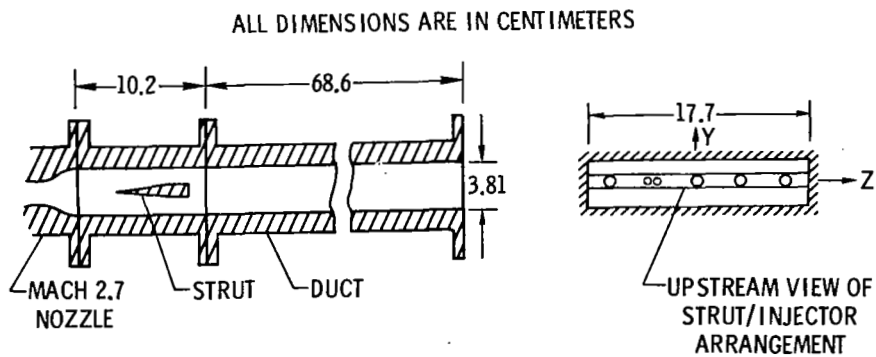

Figure 6.- Schematic of three-dimensional mixing apparatus.

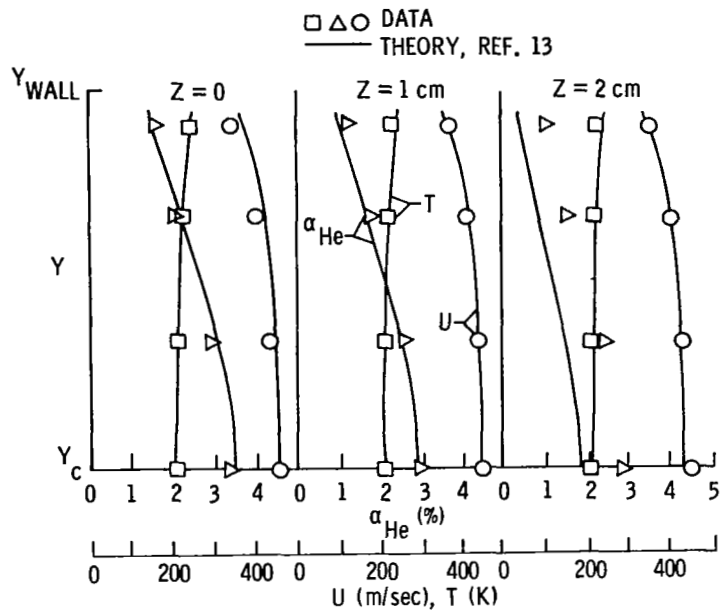

Figure 7.- Typical data-theory comparison at duct exit.

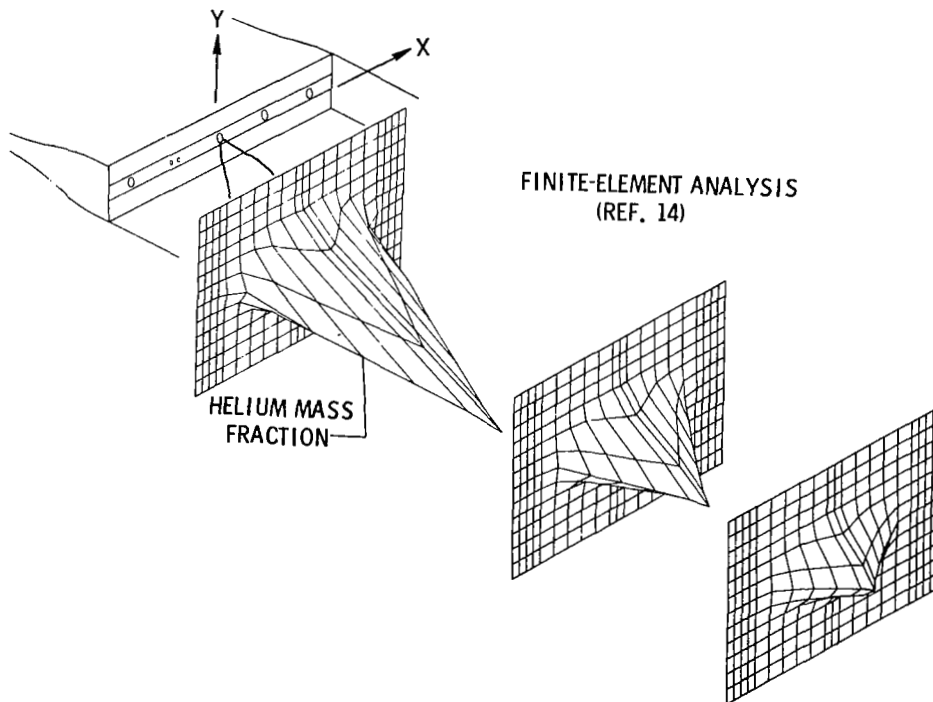

Figure 8.- Decay of central helium jet with downstream distance.