

## FLIGHT-TEST TECHNIQUES FOR WAKE-VORTEX MINIMIZATION STUDIES

Robert A. Jacobsen and M. R. Barber\*

Ames Research Center

## SUMMARY

The flight-test techniques developed for use in the study of wake turbulence and used recently in flight studies of wake minimization methods are discussed. Flow visualization has been developed as a technique for qualitatively assessing minimization methods and is required in flight-test procedures for making quantitative measurements. The quantitative techniques are the measurement of the upset dynamics of an aircraft encountering the wake and the measurement of the wake velocity profiles. Descriptions of the instrumentation and the data reduction and correlation methods are given.

## INTRODUCTION

Flight tests have played an important role in the coordinated research program to develop vortex-wake alleviation techniques. The contribution of flight testing to this program lies in three important areas: to verify that the more flexible and less expensive to operate, ground-based research facilities are suitable for the development of vortex alleviation devices and techniques; to identify, under full-scale conditions, shortcomings of any alleviation technique that might not have been evident in the small-scale test environment; and to assess the operational feasibility of the developed techniques. The operational feasibility phase has two facets. The first is the influence of the alleviation device on the operation of the generating aircraft, but this subject is outside the scope of this paper. The second facet is to demonstrate the level of alleviation attained in the operational situation.

Recent flight experience has emphasized the importance of flight tests in complementing and focusing the research efforts in the ground-based facilities. As a result of wind-tunnel studies at Ames and Langley Research Centers, it

---

\*Flight Research Center.

was discovered that raising the outboard flap segment in the landing configuration of a Boeing 747 markedly reduces the rolling moments induced on a following model (ref. 1). Flight tests confirm that the vortex-induced upset can be reduced substantially through this flap modification. However, the flight-test results show that the alleviation is greatly diminished when the landing gear is extended (ref. 2). This effect of gear was unexpected and hence had been overlooked in the wind tunnels. The flight test, therefore, had two important effects - confirming that the wind-tunnel test results were meaningful and focusing future research on configurations that provide alleviation in the presence of a lowered landing gear.

Three flight-test techniques for wake turbulence research have evolved. The development of these techniques was initiated before the wake-vortex alleviation program so that the hazards associated with the vortex systems could be documented from a number of jet aircraft. The three techniques are flow visualization, upset measurements of encountering aircraft, and velocity profile measurements.

Flow visualization is useful in comparisons of various alleviation configurations. However, the primary value of flow visualization is to make it feasible for the pilot of a probe aircraft to locate the vortex and to penetrate its core so that the other two techniques can be applied. Historically, the first flow visualization simply relied on the entrainment of the jet exhaust in the vortices. This system was marginally successful for the tightly rolled-up vortex systems generated by transport aircraft in the cruise configuration and, for some aircraft, in the landing configuration. However, for most aircraft in the landing configuration, with or without alleviation, specially developed flow visualization techniques must be used. As might be expected, the more effective an alleviation technique is in eliminating or spreading the organized flow within the wake, the more difficult it becomes to mark the wake effectively.

Techniques for evaluating the hazard due to a wake vortex by measuring the upset of a penetrating aircraft were well developed before the alleviation program was initiated. Early efforts included measurements of the wakes of large jet aircraft (such as the C-5A), with a number of smaller aircraft ranging in size from a Convair CV-990 to a Cessna 210 (refs, 3-6). Response

measurements were used in the earliest flight-test program to assess the effect of an alleviation device.

This experiment was conducted at Ames in 1970 using a spoiler on the wingtip of the CV-990 (ref. 7). This device had been developed in the wind tunnel on the basis of tuft-grid studies. In flight, the effect of the spoiler was determined by mounting it on one wingtip while leaving the other tip clean. The Ames Learjet was used to probe the wake from one wingtip and then the wake from the other. The pilots could not discern any effect of this device. However, data reduction did indicate that there was some alleviation effect. The principal result of this flight program was to convince researchers at Ames that more definitive flight-test techniques were needed to effectively evaluate the alleviation techniques.

The desire for a more definitive technique led to the development of methods for measuring velocity profiles. Such measurement had been made in flight earlier at Langley using angle of attack and sideslip vanes (see ref, 8). However, it was felt necessary to develop instruments with higher frequency response characteristics than vanes. There are several advantages to measuring the velocity profile in the wake. First, it may provide more insight into the processes actually occurring in the flow field leading to vortex dissipation. Second, unlike response measurements that cannot be extrapolated to other sizes of aircraft, a velocity profile can be used to estimate the rolling moment imposed on any aircraft. Finally, these measurements, along with simultaneous measurements of aircraft response, can be used to verify response calculation and to develop improved methods of making these calculations.

In the following sections, the current state of development of each flight-test technique is discussed in greater detail.

## FLIGHT-TEST TECHNIQUES

### Flow Visualization

Flow visualization has been a primary concern throughout the development of wake turbulence flight-test techniques. Not only is it a useful tool for observing the mechanisms of vortex decay, it is also a necessary element in

any of the probe aircraft work. The visualization provides a target for the pilot of the probe aircraft to increase the probability that the wake encounters provide the maximum information possible. Without the target provided by the visualization, an extremely large number of passes through the estimated location of the wake would be required to provide a significant number of encounters. Even then, there would be no assurance that the strongest portion of the wake had been measured. In fact, it has proven difficult to develop flow visualization that defines the wake well enough at separation distances of 2 to 10 nautical miles to enable a large percentage of the probe aircraft encounters to penetrate the core region of the vortex.

The visualization used for most of the vortex alleviation flight tests has been provided by "smoke generators" built for NASA by Frank Sanders Aircraft Co. (Long Beach, Calif.). Figure 1 shows one of these devices - an aluminum cylinder approximately 25 cm (10 in.) in diameter and 1.4 m (4.5 ft) long with a 0.7-m (2.2-ft) tailpipe. The "smoke" generated by this device is actually small droplets of mineral oil created when oil vapor expelled by the smoke generator is condensed by the cooler ambient air. A combustor contained within the cylinder generates the heat used to vaporize the mineral oil. The oil is sprayed into the exhaust of the combustor in the tailpipe extending behind the cylinder. The fuel for the combustor and the mineral oil are contained in tanks located within the cylinder. The self-contained tankage provides for 20 min of operation with ambient air being used to support the combustion. At the approach speeds used for much of the wake turbulence testing, the operation of the combustor on ambient air is marginal. The device was modified recently to allow engine bleed air to be used in the combustor. This change greatly improved the "smoke" production, but the operating time is reduced to 10 min.

In a typical installation on a research aircraft, one or more smoke generators is mounted under the wing at each spanwise location where a discrete vortex is expected to form (fig. 2). These locations typically include the wingtip, edges of the flap segments, and the wing/fuselage junction. The two most recent installations have both been on a B-747 used for the wake alleviation program at Flight Research Center (Edwards Air Force Base, Calif.). In the first of the two installations (fig. 2), a single smoke generator was

mounted at the tip, one at the outboard edge of the outboard flap segment and one at the outboard edge of the inboard flap segment of each wing. The flow visualization provided by this installation was often marginal and improvements were made to the system before the next series of tests on that aircraft. Those improvements included doubling the number of smoke generators at each of the previous six locations and adding two at the inboard edge of each inboard flap. Each of these 16 smoke generators had bleed air from the jet engines ducted to their inlets to further improve their performance. This installation has produced excellent results. An example of the flow visualization produced by this arrangement is demonstrated in figure 3.

A second type of flow visualization has been used which also performed adequately for either flow-field observation or for marking the wake to facilitate probing. The wake in this case was marked with an inert powder blown into the airstream at any location of interest. The inert powder used is finely ground diatomaceous earth. Figure 4 is a diagram of a typical installation. The powder is contained in tanks located in the aircraft fuselage with tubing extending along or inside the wing to the desired location. When visualization is desired, the tanks are pressurized using bottled gas that expels the powder out the tubes. This system is easy to install and is aerodynamically clean, but the visualization period is relatively short. The powder is bulky and, for the size of tanks and delivery lines used, it is expelled in about 90 sec. The tanks must then be refilled (which can be done in flight) before additional visualization can be accomplished. This type of flow visualization was used on a DC-3 and a DC-10 in programs at Flight Research Center (ref. 5) and on the Augmentor Wing Jet STOL Research Aircraft at Ames (ref. 9). Figure 5 shows the installation of an inert powder system on a DC-10 and figure 6 shows the visualization of the wake of a DC-3 using a similar system.

### Flight Measurements

Flight tests to determine the relative strengths of vortex systems have been made by penetrating the wake to measure either the upset imparted to a probe aircraft or the flow velocities within the wake. As noted previously, either technique requires flow visualization. In addition, both techniques require that the distance between the probe and wake-generating aircraft be

known, and that limits be placed on this distance to ensure that structural limit loads are not exceeded.

Three different methods have been used in wake turbulence flight programs conducted by NASA to measure the distance between the probe aircraft and the aircraft that generated the wake. The first technique requires the use of two ground radars. By tracking each aircraft to establish its position in space as a function of time, the distance between the two aircraft can be determined. This technique has been used in NASA programs at Edwards and Vandenberg Air Force Bases. The information is communicated to the probe aircraft pilot to aid him in controlling the experiment. The second technique used when radar facilities were not available is to conduct the flight test while flying a radial toward (or away from) a distant Distance Measuring Equipment (DME) ground station. The probe aircraft pilot calls out his distance to that station as he encounters the wake. At that time, the pilot of the wake-generating aircraft calls out his distance to the station and the difference in the two is the separation between the aircraft. Both of these techniques are inconvenient in that extensive ground facilities are required or a communication link is required that can, at times, be confusing.

To overcome these difficulties, a third system was developed: a pair of airborne DME's was modified (by Sierra Research Corp., Buffalo, New York) so that one of the pair performed as a beacon and the other as an interrogator of that beacon. The beacon is mounted in the lead aircraft and the interrogator is mounted in the probe aircraft. A direct and continuous measurement of separation distance is obtained completely independent of ground facilities. This system has been used in all of the recent wake turbulence programs.

Concern for the structure of the probe aircraft makes it necessary to place limits on the probing technique, especially as separation distances are reduced. Three methods have been used to assure the safe operation of the probe aircraft. The first method is to limit the airspeed of the probe aircraft to a value that will prevent the loads on any aerodynamic surface from reaching their limits. For this calculation, each surface is assumed to be stalled at 1.3 times the maximum lift coefficient for that surface to allow for the "dynamic stall" effect. Knowing the limit load capability of that surface then allows a maximum allowable airspeed to be computed. This procedure is

followed for each surface and the lowest airspeed is used as the operational limit. It is then assured that any aerodynamic situation encountered will not cause structural damage. This method has been used at Ames Research Center to assure the safe operation of their Learjet probe aircraft in wake turbulence testing.

The second method for assuring safe operation is to monitor the loads in the critical locations of the probe aircraft structure and telemeter that information to the ground. At each separation distance where probing is done, enough encounters are obtained to ensure that the maximum loads possible at that location have been imposed on the probe aircraft. If these maximum loads are less than a predetermined percentage of the yield loads, then the separation distance can be reduced. Once the measured loads exceed that predetermined percentage of the yield load, no probing is performed at a closer separation distance. This technique has been used at Flight Research Center with their T-37 probe aircraft.

The third technique used to establish a lower limit on the separation distance for probe encounters is the subjective opinion of the pilot of the probe aircraft. If, at any time, the pilot feels that continued probing at closer separation distances or at that same separation distance cannot be done safely, that series of encounters is stopped.

*Upset measurements* - Measurements taken to derive the moments induced on an aircraft subjected to wake turbulence have become known as "upset measurements." Actually, it is necessary to measure more than simply the upset of the probe aircraft. The control inputs, angular rates, airspeed, and angles of attack and sideslip must be known to account for those angular accelerations resulting from the aerodynamic characteristics of the probe aircraft. The separation distance between the two aircraft and the encounter altitude are also required to correlate the data.

Upset measurements are taken with the flight path of the probing aircraft nominally parallel to the wake axes (hence the name "parallel probes") (fig. 7). When probing the wake of an unfamiliar configuration, the initial encounter with the wake is made at a separation distance large enough to ensure that the resulting forces will not severely load the structure of the aircraft. This is an additional precaution to the safe operation procedures previously

described. As the probe aircraft encounters the wake, the pilot performs his task in one of two modes. He can hold the controls fixed, allowing the upset to remove the aircraft from the wake, or he can attempt to hold the probe airplane as nearly centered in a vortex as possible. Either action produces the desired data, but the pilot may obtain more subjective information by using a combination of the two. This procedure is repeated several times at each separation distance to increase the probability that the maximum possible induced accelerations of the probe aircraft were achieved.

The instrumentation used to obtain the data required to derive the induced moments is, generally, that which would be typical for a study of handling qualities. The three-dimensional aircraft dynamics are measured by angular accelerometers, rate and attitude gyros, and linear accelerometers. The deflections of the control surfaces are measured as are airspeed, altitude, angles of attack and sideslip, and separation distance. Typical roll axis data are shown in figure 8.

Figure 9 is a block diagram of the data-reduction process. During an encounter, the velocity gradients in the flow field to which the probe aircraft is being subjected can be quite high. As a result, the angles of attack and sideslip measured on the nose boom or at any single point on the aircraft cannot be considered representative of the effective flow-field angularity to which the whole airframe is subjected. Consequently, it is necessary to compute an effective angle of attack and sideslip from the measured linear accelerations and angular rates. The angular accelerations that would have been caused in still air by the aerodynamic forces and control inputs are computed. When subtracted from the measured angular accelerations, the accelerations induced by the vortex flow are derived. Computed aerodynamic and control accelerations and net acceleration due to the vortex flow are shown in figure 10 for the same encounters shown in figure 8. The measured roll acceleration is repeated.

A roll acceleration parameter, convenient for comparative purposes, was developed to relate the vortex-induced roll acceleration,  $\dot{p}_{\text{vortex}}$ , to the maximum roll acceleration capability of the aircraft using maximum aileron deflection  $\dot{p}_{\delta a_{\text{max}}}$ . The ratio  $\dot{p}_{\text{vortex}}/\dot{p}_{\delta a_{\text{max}}}$  indicates how severe the induced moment was. The physical meaning of this parameter is that, when a value of



unity is reached, the pilot could exactly counter the vortex-induced roll acceleration with maximum deflection of the ailerons. Similar parameters can be determined for accelerations in the pitch and yaw axes. For each encounter behind a given configuration, the peak values of this roll-acceleration parameter are plotted against the separation distance at which they occurred (fig. 11). Assuming that the highest values at each distance represent the maximum upset expected at that location, an upper bound to the data is constructed. The separation distance defined by the intersection of that boundary and the line for a unity roll acceleration parameter is used in comparisons with values obtained in a similar manner from data obtained during tests of other aircraft or configurations. An example of how these comparisons are made is shown in figure 12, where the separation distance for unity roll acceleration parameter is plotted against the gross weight of the wake-generating aircraft for several sizes of probe aircraft. This figure demonstrates that the upset received by a given probe aircraft is decreased as the gross weight of the wake-generating aircraft is decreased. Similar comparisons can be made for the flight-test results of wake-vortex alleviation methods.

*Velocity profile* measurements - The need for more definitive information on the vortex-wake phenomenon led to the development of another flight-test technique. Use of this technique results in measurements of the velocity profiles in the wake, which will allow comparisons of the wake structure with theories (ref. 10). This can be especially useful in the wake alleviation work by more clearly defining the changes in the wake structure caused by an alleviation technique.

These measurements require a completely different technique in procedure, instrumentation, and data reduction. The flow velocities must be measured by sensors with higher frequency response characteristics than normally used in handling qualities research, and the aircraft motion must be measured for use in correcting the velocity data. The separation distance is again required to correlate the data.

The flight-test procedure used to obtain velocity profile data is considerably different from that used during upset measurements (fig. 13). The flight path of the probing aircraft is across the wake to effectively traverse the flow field with the velocity-measuring probe. Ideally, the flight path

should be in a plane perpendicular to the wake axes to minimize the motion excursions for which corrections must be made. The limited capability of the flow visualization systems to mark the wake results in an inability to see the wake well enough from right angles to enable the pilot of the probe aircraft to penetrate the vortex cores consistently. As the crossing angle is reduced, the apparent density of the flow visualization medium is increased, thereby allowing consistent core penetrations. Local atmospheric conditions and the angle of the sun relative to the two aircraft affect visualization as well. Experience has shown that crossing angles of from  $250^\circ$  to  $45^\circ$  are adequate for this task. These lower crossing angles have the additional advantage of allowing a shorter time between crossings because a turn of only  $50^\circ$  to  $90^\circ$  is required to traverse back across the wake. This saving of time between wake crossings allows more data to be obtained in the amount of time allowed by the flow visualization system.

As with the upset measurement procedures, wake encounters are begun at separation distances large enough to assure safe operations. A zigzag flight path is flown while the separation distance is continually reduced until a predetermined minimum separation distance is reached. This minimum separation distance is set for safety reasons and, as for upset measurements, is based on computed loads, extrapolated load measurements, or probe pilot decisions. Once the minimum separation distance is reached, a  $360^\circ$  turn is initiated which sets the probe aircraft up for additional data at a larger separation distance. This procedure is repeated several times until adequate data are acquired for that wake-generating aircraft configuration.

The frequency content of the velocity data being recorded as the probe aircraft traverses the wake is considerably higher than that normally seen in aircraft dynamics work. Assuming reasonable values for the probe aircraft velocity and the vortex core size of 120 m/sec (400 ft/sec) and 3 m (10 ft), respectively, the apparent frequency of the approximately sinusoidal input recorded as the vortex core is penetrated is 40 Hz. This frequency is higher than conventional research aircraft flow angularity sensors are able to measure reliably. Three types of sensors have been used to this purpose. Angle of attack and sideslip vanes (fig. 14) have been used by Langley Research Center on a T-33 research aircraft (ref. 8). A five-hole pitot tube (fig. 15) has been used at Flight Research Center on a T-37 probe aircraft. At Ames

Research Center, a three-component, hot-wire anemometer (fig. 16) has been used on a Learjet probe aircraft (ref. 11). The instrumentation system and data-reduction technique described below is that for the hot-wire anemometry sensors and is typical of the data-reduction technique required for the others as well. In addition to the high-frequency velocity measurements, information on the probe aircraft dynamics is required. These are measured by angular and linear accelerometers and angular rate and attitude gyros. The range between the aircraft whose wake is being studied and the probe aircraft is measured directly by a pair of modified DME's as in the upset measurements.

The data-reduction process is indicated by the flow chart in figure 17. The airborne-recorded analog data are digitized at the rate of 1000 samples/sec. (This rate is necessary because of the high-frequency content of the data.) The wake velocities are first computed from the hot-wire data in an axis system aligned with the body axes of the aircraft, and corrections are made for the vertical velocity and pitch rate of the aircraft. Corrections are also made for the apparent vertical and lateral velocities that result from the effective angles of attack and sideslip generated as the aircraft reacts to the induced forces. The three components of velocity are then resolved into an axis system aligned with the axis of the vortex using the relative heading for each pass across the wake. The flight path of the probe is computed from the initial airspeed and the measured vertical accelerations and pitching excursions. In this way, a velocity distribution along a known path in space is determined.

The velocity profile measured at a separation distance of 2.9 nautical miles behind a B-747 in its normal landing configuration is presented in figure 18. All three components of velocity are shown, the top one being the vertical velocity component defined as positive upward, the middle trace is the lateral component defined as positive to the left, and the bottom trace is the axial velocity component defined positive toward the aircraft that generated the wake. Comparing these data with that of the next figure demonstrates the ability of this system to show the effects of vortex-wake alleviation in the measured flow field. A comparison of figures 18 and 19 indicates the reduction in the three components of velocity in the wake of the B-747 at 2.2 nautical miles with the outboard flaps retracted.

Another purpose for which these data can be used is to understand, or at least document, the changes in the vortex structure as it ages. Since no two traverses of the wake are the same, these comparisons are best made by fitting data of various ages with a mathematical model and observing the changes in the model parameters as the vortex ages. For the initial attempts at modeling these data, a pair of Lamb vortices was selected. This representation is convenient because the formulation is analytic. Matching the computed velocities to the measured data along the actual flight path was accomplished using the locations of the two vortices, the circulation of each vortex, and their core size as parameters. The match was done in a least squares sense on the vertical and lateral velocity components simultaneously. A result of that matching procedure is seen in figure 20, where the velocities computed from the model as they would have been measured along the flight path are compared with the measured data. If the wake can be adequately represented by a single pair of vortices, this procedure results in a satisfactory match. Modeling the wake at various separation distances and comparing the results can show the decay of the velocities in the vortex (fig. 21). The reduction of maximum velocity is seen as the separation distance increases.

An application of this mathematical modeling technique to the wake alleviation work is shown in figure 22, where a model of the tangential velocity profile of the B-747 wake at separation distances up to 3.1 nautical miles in normal landing configuration is compared with that for the same airplane's wake at distances as close as 1.0 nautical mile with the outboard flap segment retracted. Even though the profiles for the latter case are at closer separation distances, the peak tangential velocity is reduced and the effective core size increased.

#### REFERENCES

1. Corsiglia, V. R.; Rossow, V. J.; and Ciffone, D. L.: Experimental Study of the Effect of Span Loading on Aircraft Wakes. NASA TM X-62,431, 1975.
2. Smith, H. J.: A Flight Test Investigation of the Rolling Moments Induced on a T-37B Airplane in the Wake of a B-747 Airplane. NASA TM X-56,031, 1975.

3. Andrews, W. H.: Flight Evaluation of the Wing Vortex Wake Generated by Large Jet Transports. NASA FWP-18, presented at Boeing/AFOSR Symposium on Aircraft Wake Turbulence, Seattle, Wash., Sept. 1970.
4. Andrews, W. H.; Robinson, G. H.; and Larson, R. R.: Exploratory Flight Investigation of Aircraft Response to the Wing Vortex Wake Generated by Jet Transport Aircraft. NASA TN D-6655, 1972.
5. Andrews, W. H.; Tymczyszyn, J. J.; Jacobsen, R. A.; and Drinkwater, F. J., III: Flight Investigation of the Response of Wide-Body Tri-Jet Aircraft to the Wing Vortex Wake Generated by Large Transport Aircraft. NASA Flight Research Center Working Paper FWP-35, Feb. 1973.
6. Barber, M. R.; Kurkowski, R. L.; and Garodz, L. J.: Flight Test Investigation of the Vortex Wake Characteristics Behind a Boeing 727 During Two-Segment and Normal ILS Approaches. NASA TM X-62,398, 1975.
7. Corsiglia, V. R.; Jacobsen, R. A.; and Chigier, N.: An Experimental Investigation of Trailing Vortices Behind a Wing with a Vortex Dissipator. Presented at Boeing/AFOSR Symposium on Aircraft Wake Turbulence, Seattle, Wash., Sept. 1970.
8. Verstynen, H. A., Jr.; and Dunham, R. E., Jr.: A Flight Investigation of the Trailing Vortices Generated by a Jumbo Jet Transport. NASA TN D-7172, 1973.
9. Jacobsen, R. A.; and Drinkwater, F. J., III: Exploratory Flight Investigation of Aircraft Response to the Wing Vortex Generated by the Augmentor Wing Jet STOL Research Aircraft. NASA TM X-62,387, 1975.
10. Kuhn, G. D.; and Jacobsen, R. A.: Analysis of Wake Vortex Flight Test Data Behind a T-33 Aircraft. NASA CR-137,669, 1975.
11. Jacobsen, R. A.; Hot-wire Anemometry for In-Flight Measurements of Aircraft Wake Vortices. Paper presented to SFTE, Aug. 1974.

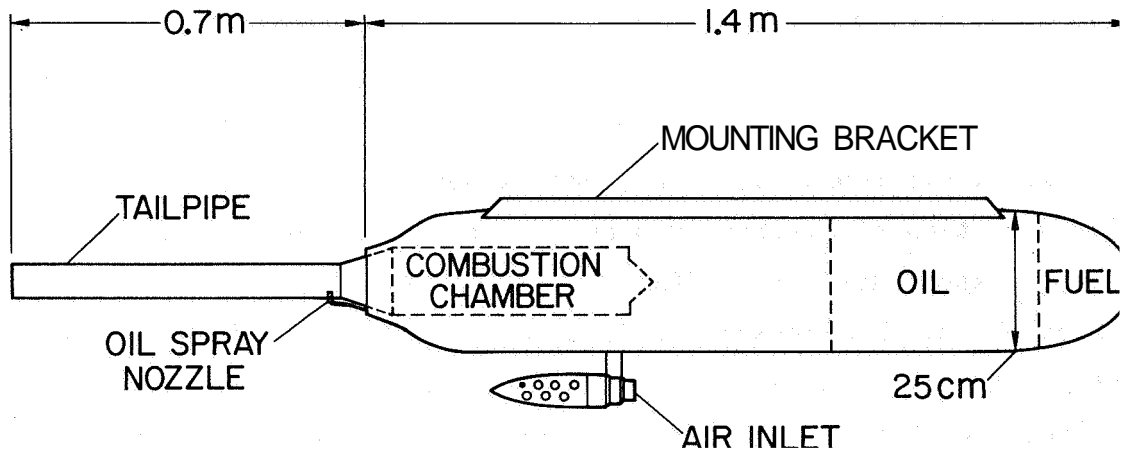

Figure 1.- Self-contained smoke generator.

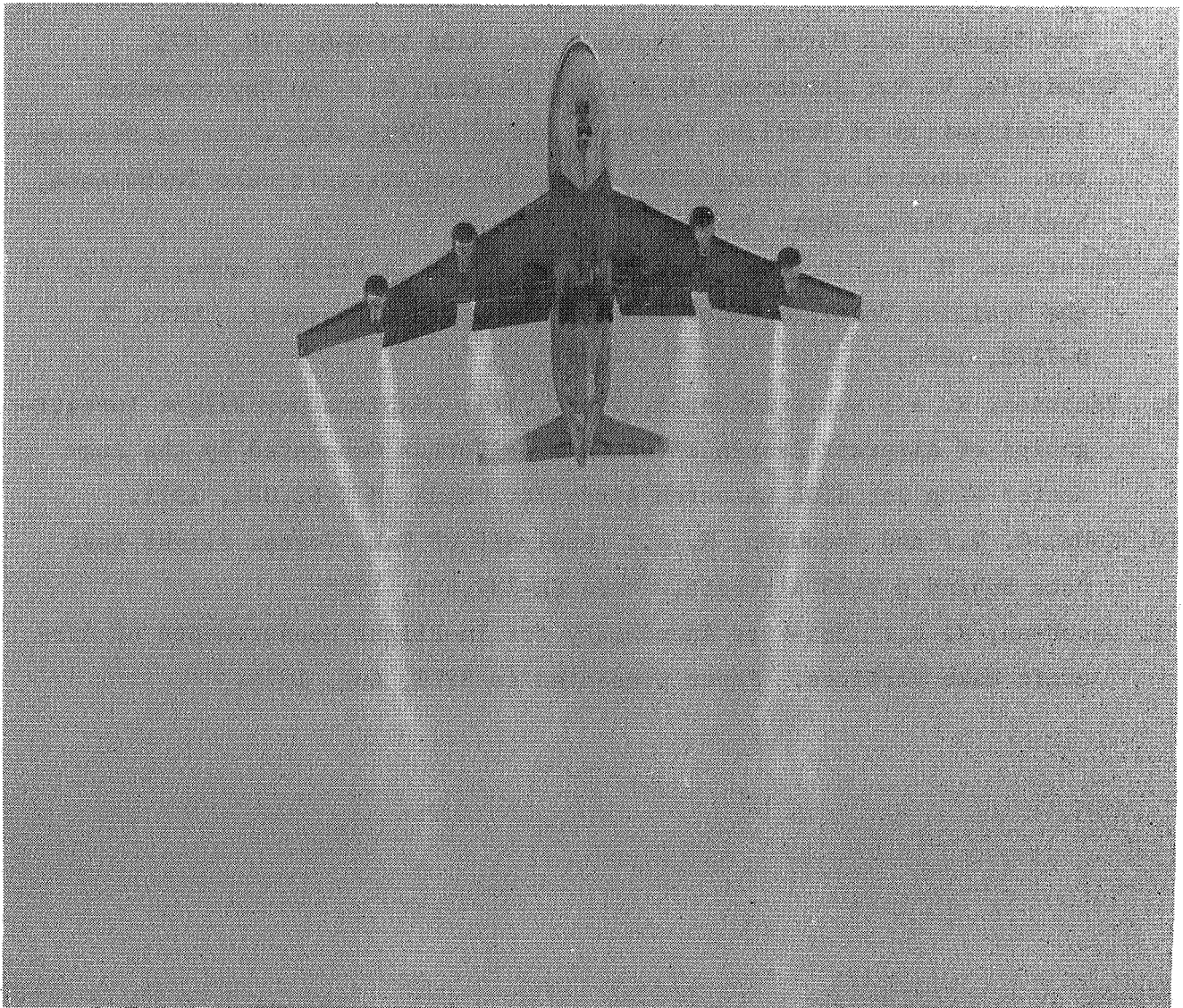

Figure 2- B-747 with six smoke generators used to mark its wake.



Figure 3.- B-747 with 16 smoke generators used to mark its wake.

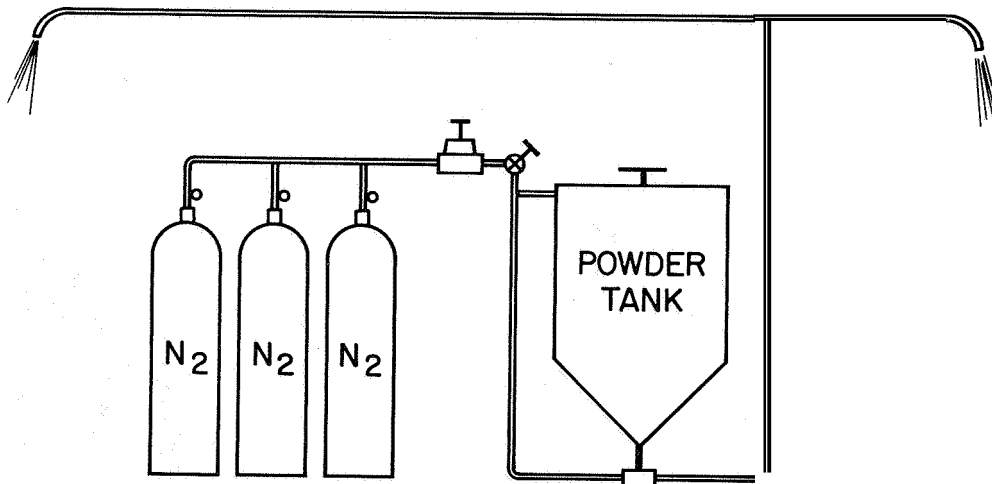

Figure 4.- Diagram of inert powder flow visualization system.

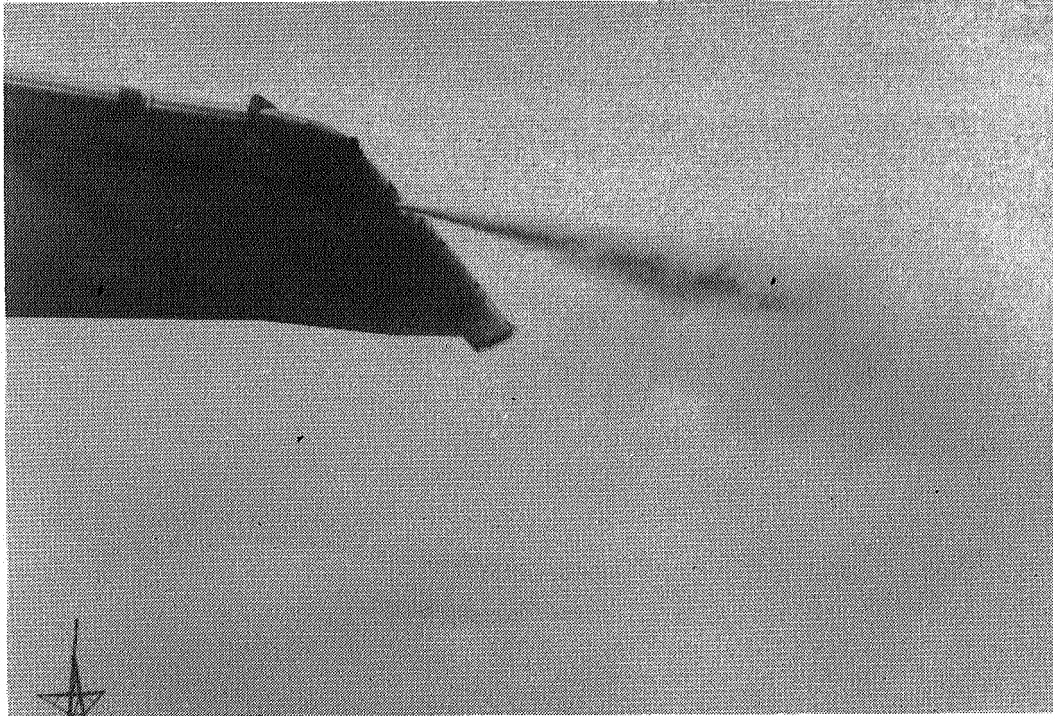

Figure 5.- Inert powder flow visualization system on DC-10.



Figure 6.- Inert powder flow visualization system on DC-3.



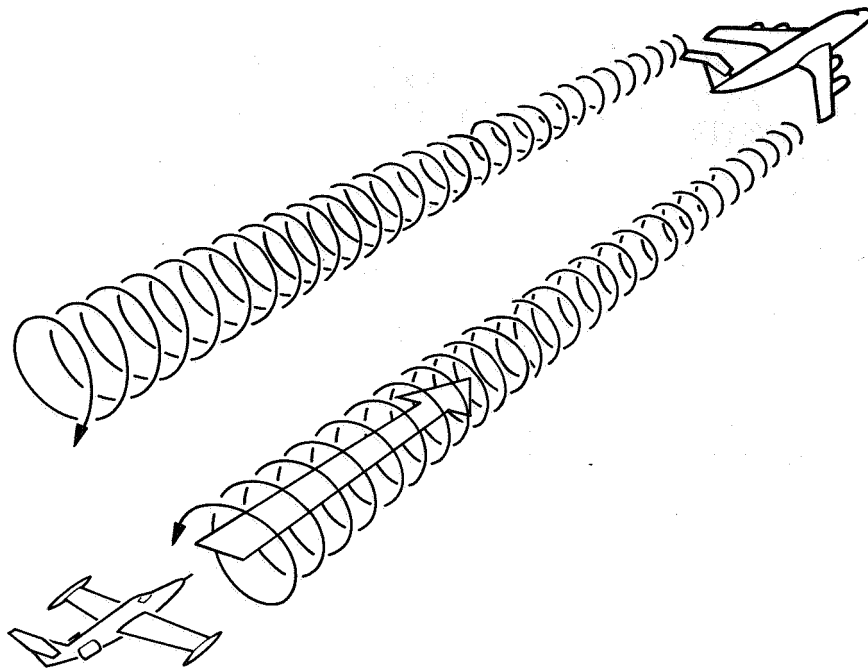

Figure 7.-Probe aircraft flight path during upset measurements of vortex wake.

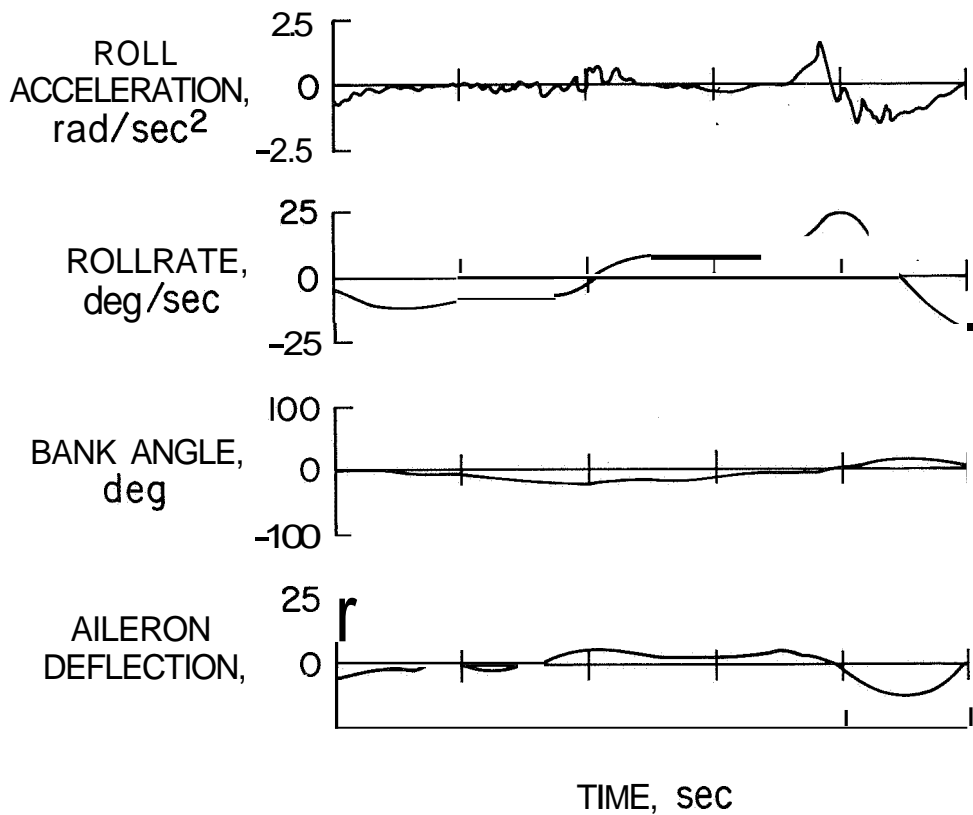

Figure 8.- Time histories of the Learjet. roll axis responses to the B-747 wake, vortex;.. separation distance of 4.7 nautical miles; B-747 with landing flaps, gear up, thrust for level flight.

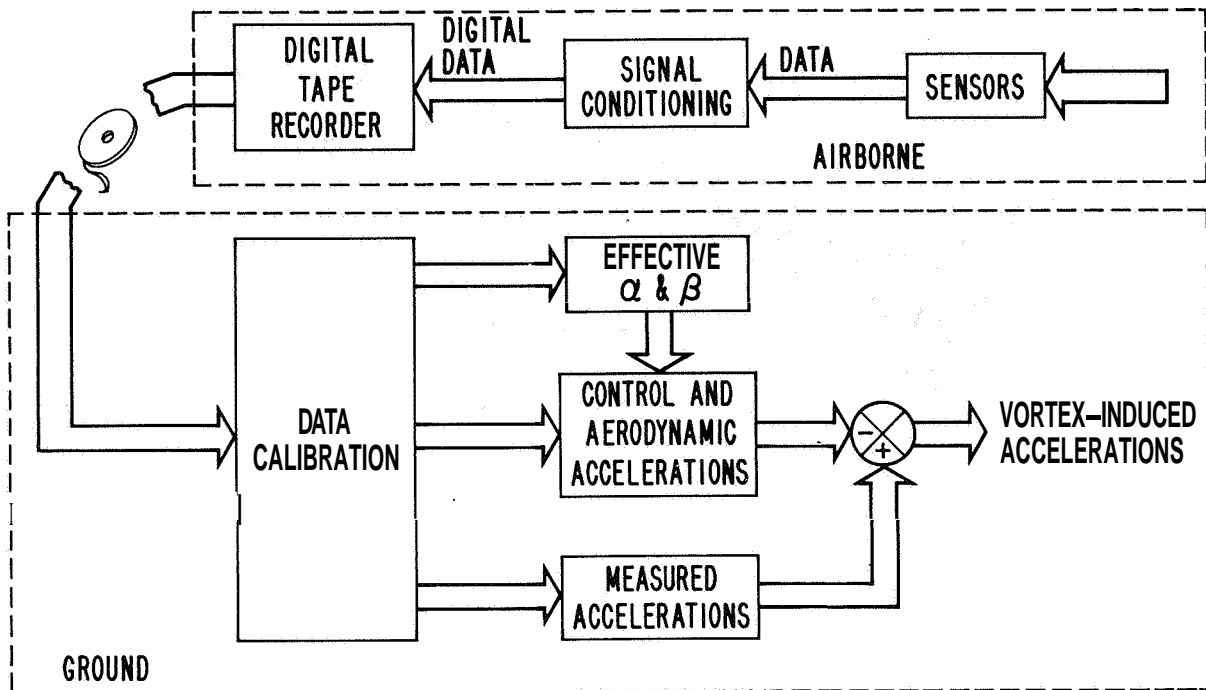

Figure 9.- Block diagram of data-reduction system used for upset measurements.

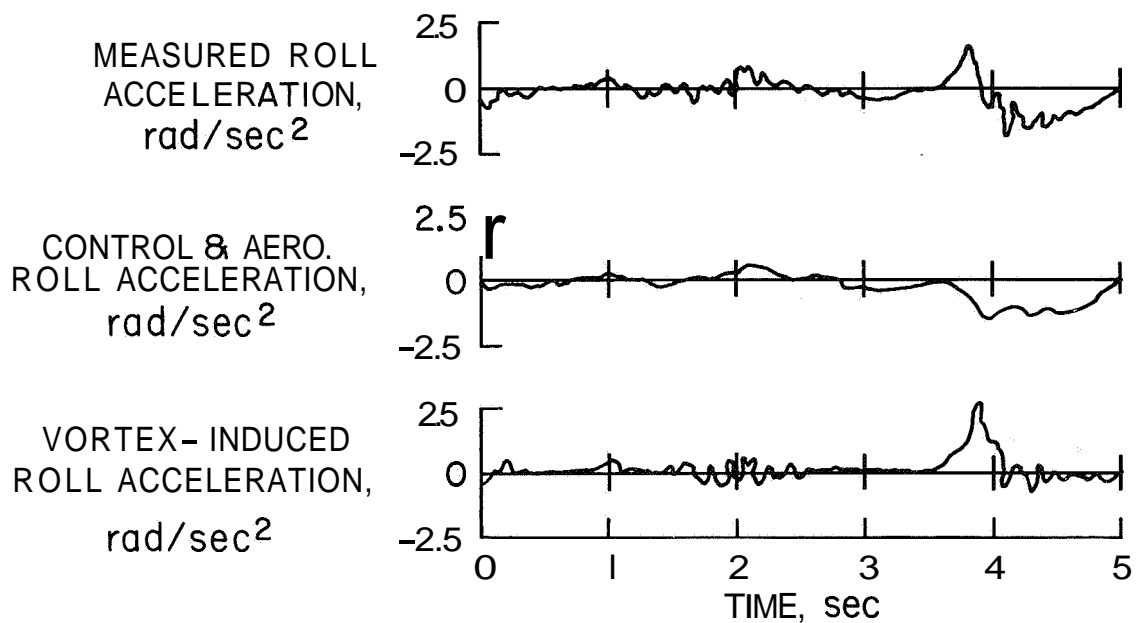

Figure 10.- Time histories of the computed control and aerodynamic roll axis acceleration and the resulting vortex-induced roll acceleration of the Learjet for the encounter in figure 8.

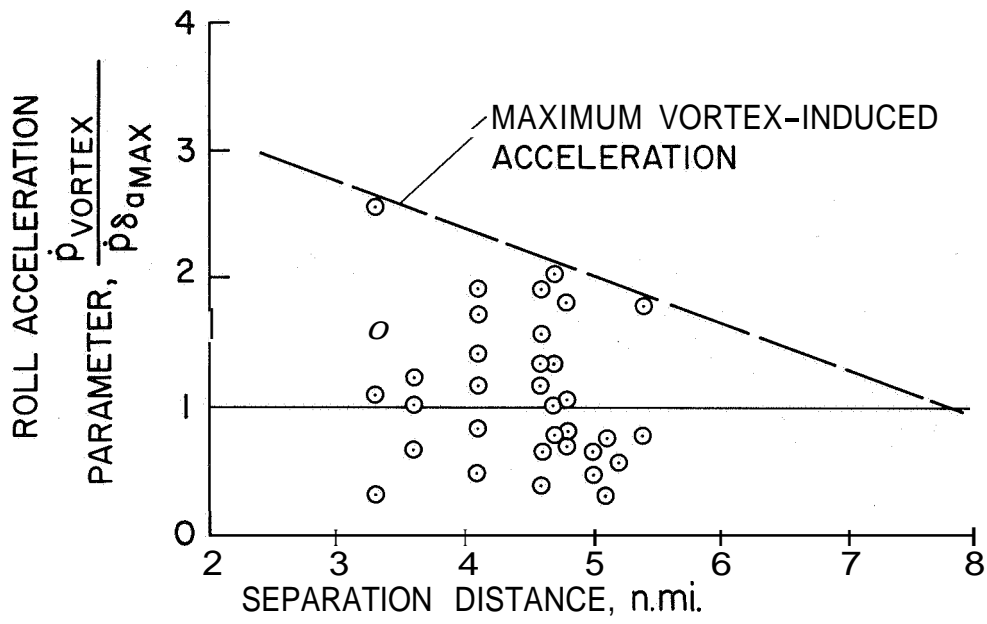

Figure 11.- Roll acceleration parameter versus separation distance for LearJet in the B-747 wake; B-747 with flaps down, gear up, thrust for level flight,  $C_L = 1.4$ .

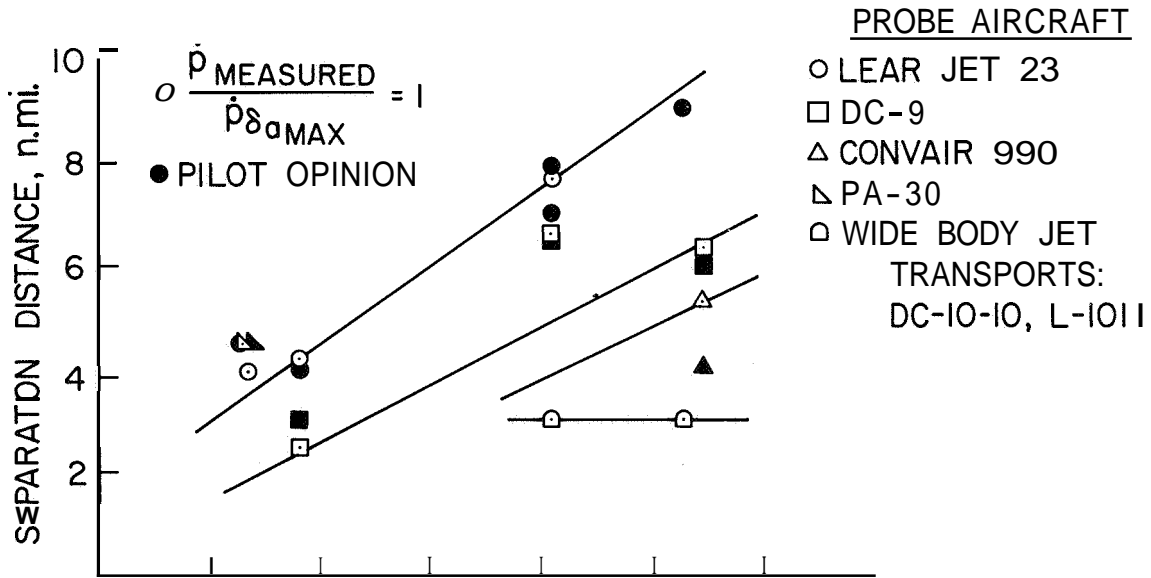

Figure 12.- Comparison of the minimum separation distances based on roll control criteria, for an operational encounter of wake vortices for several probe aircraft.

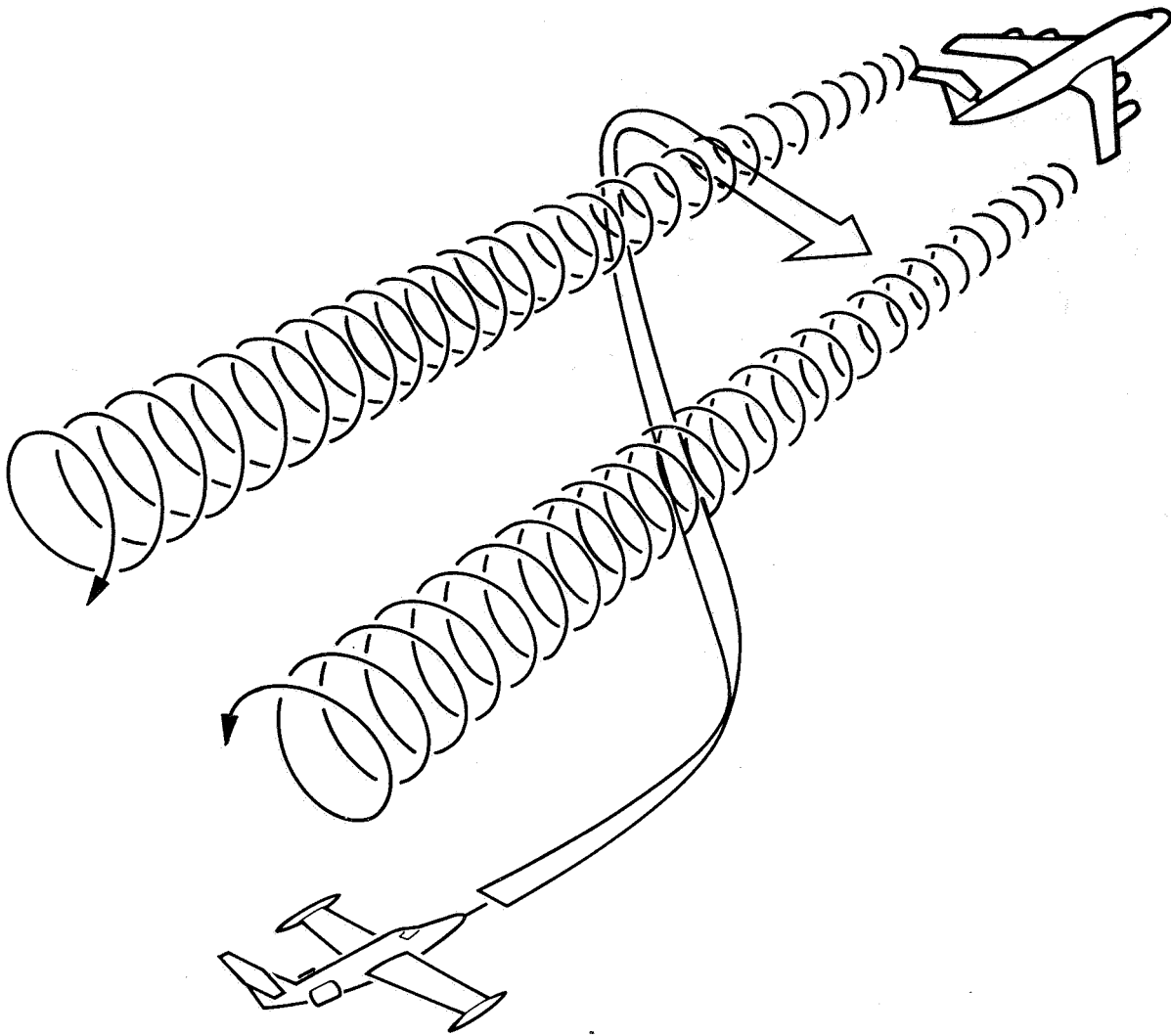

Figure 13.- Probe aircraft flight path during velocity profile measurements of vortex wakes.

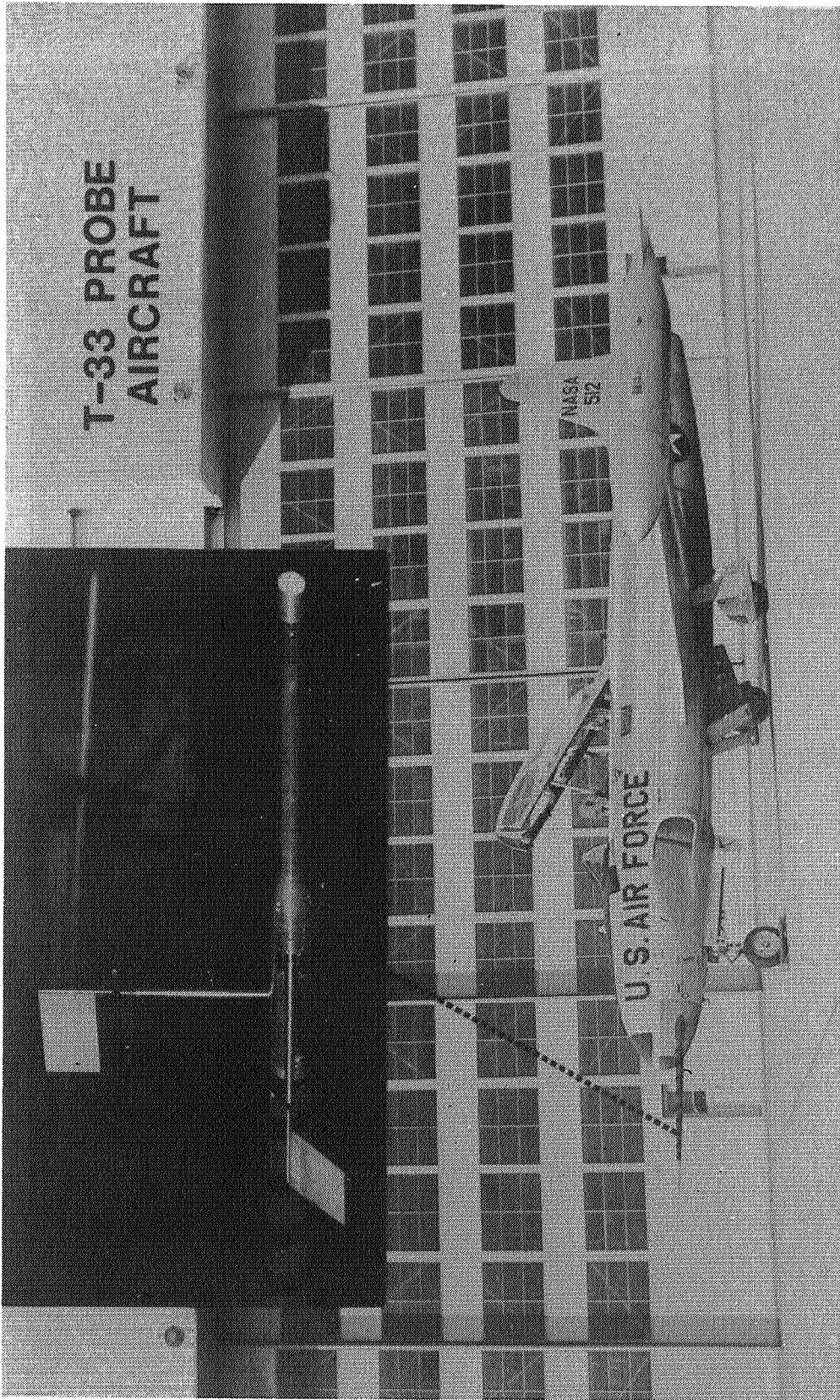
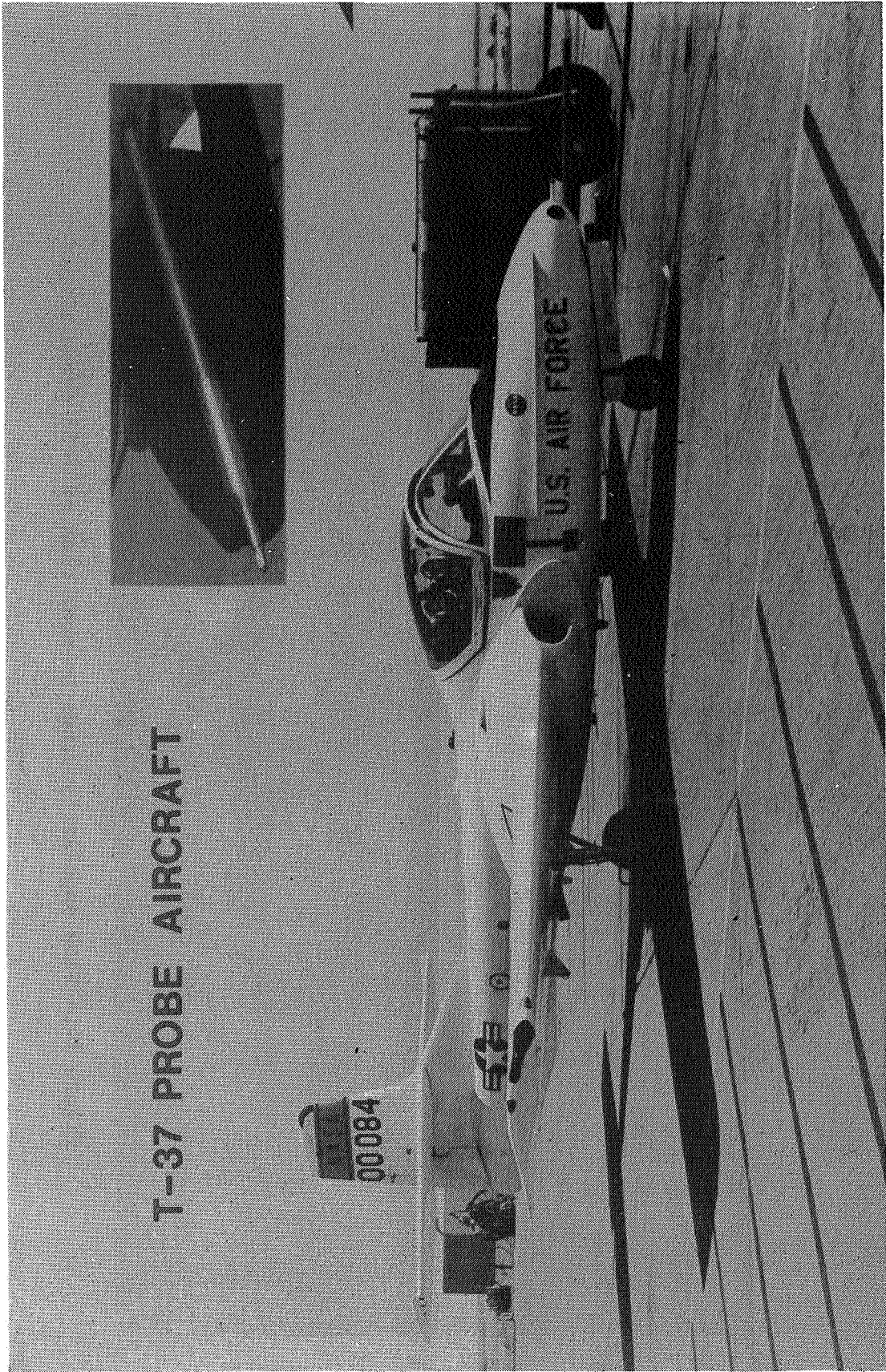
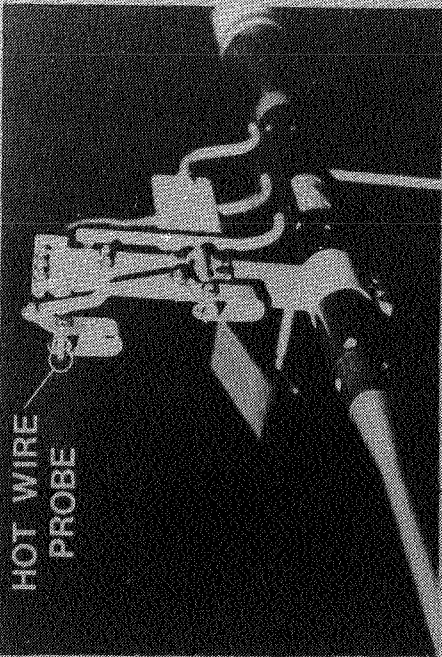

Figure 14.- Flow angularity vanes on nose boom of T-33 probe aircraft.



T-37 PROBE AIRCRAFT

Figure 15.- Five-hole pitot tube on nose boom of T-37 probe aircraft.



# LEARJET PROBE AIRCRAFT

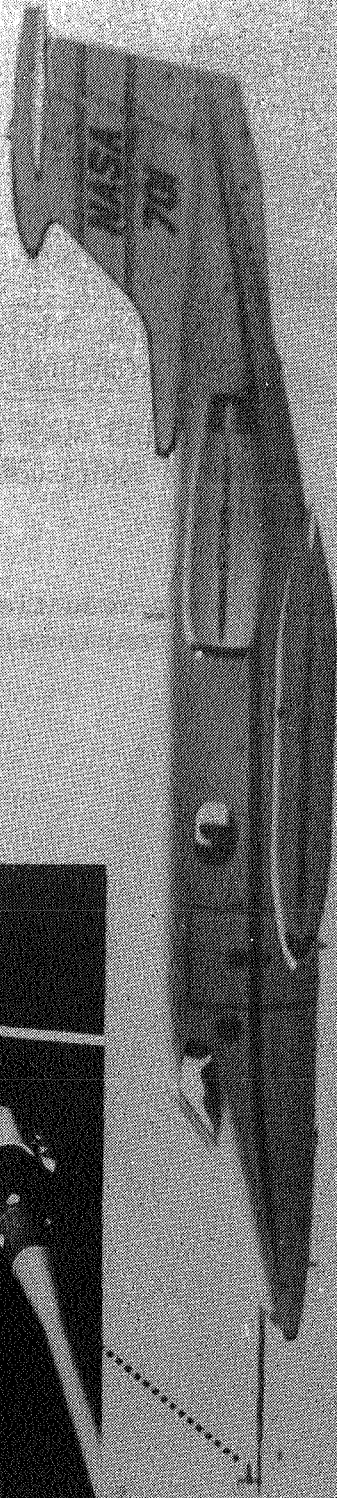

Figure 16.- Hot-wire anemometry probe mounted on nose boom of Learjet probe aircraft.

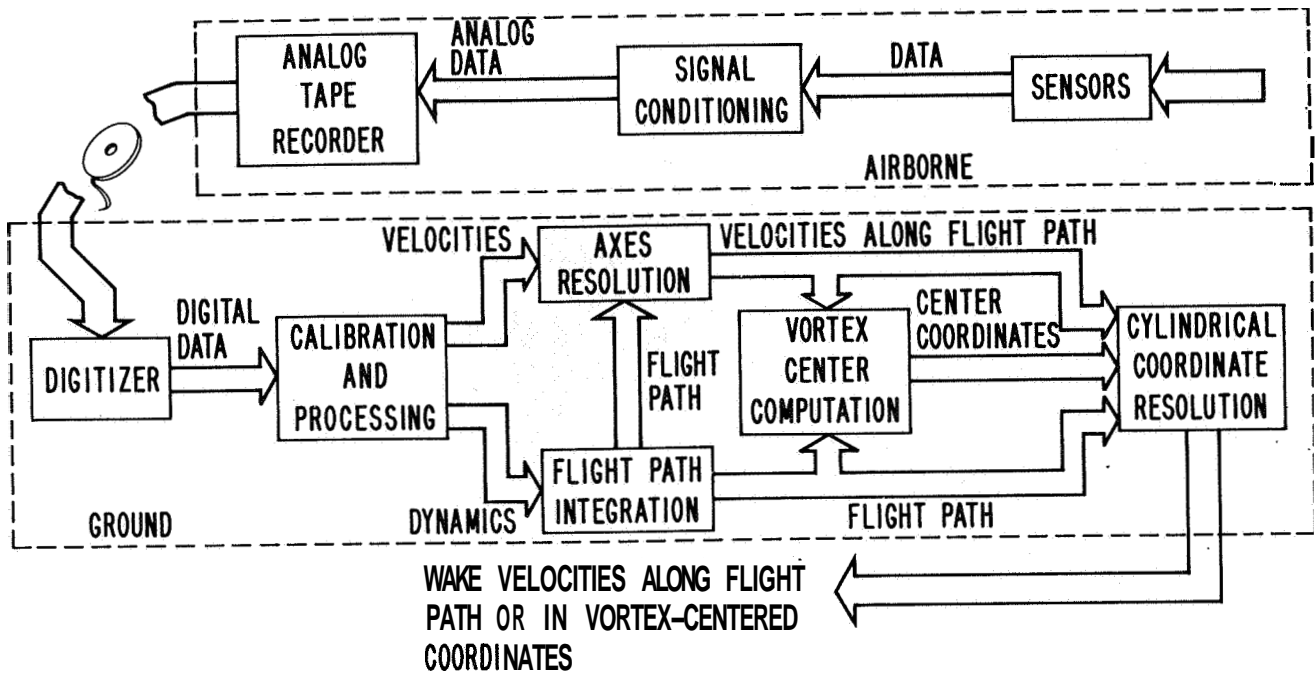

Figure 17.- Block diagram of data-reduction system used for velocity profile measurements.



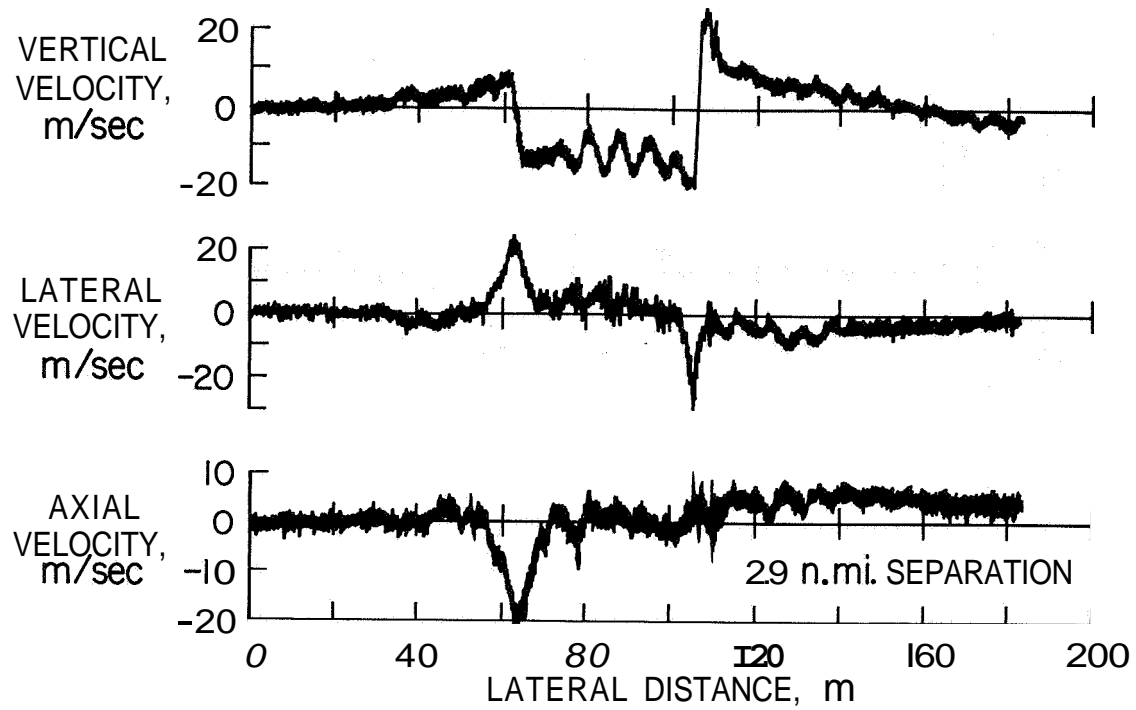

Figure 18.- Vertical, lateral, and axial velocity components in the wake of a B-747 in landing configuration.

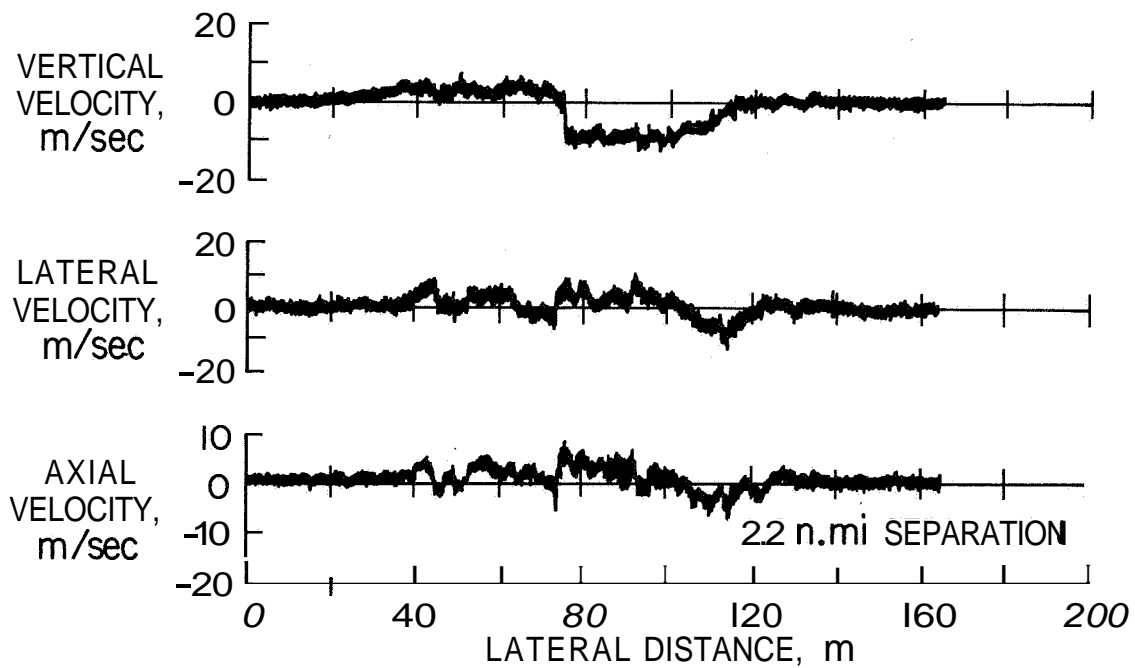

Figure 19.- Vertical, lateral, and axial velocity components in the wake of a B-747 with outboard flap retracted.

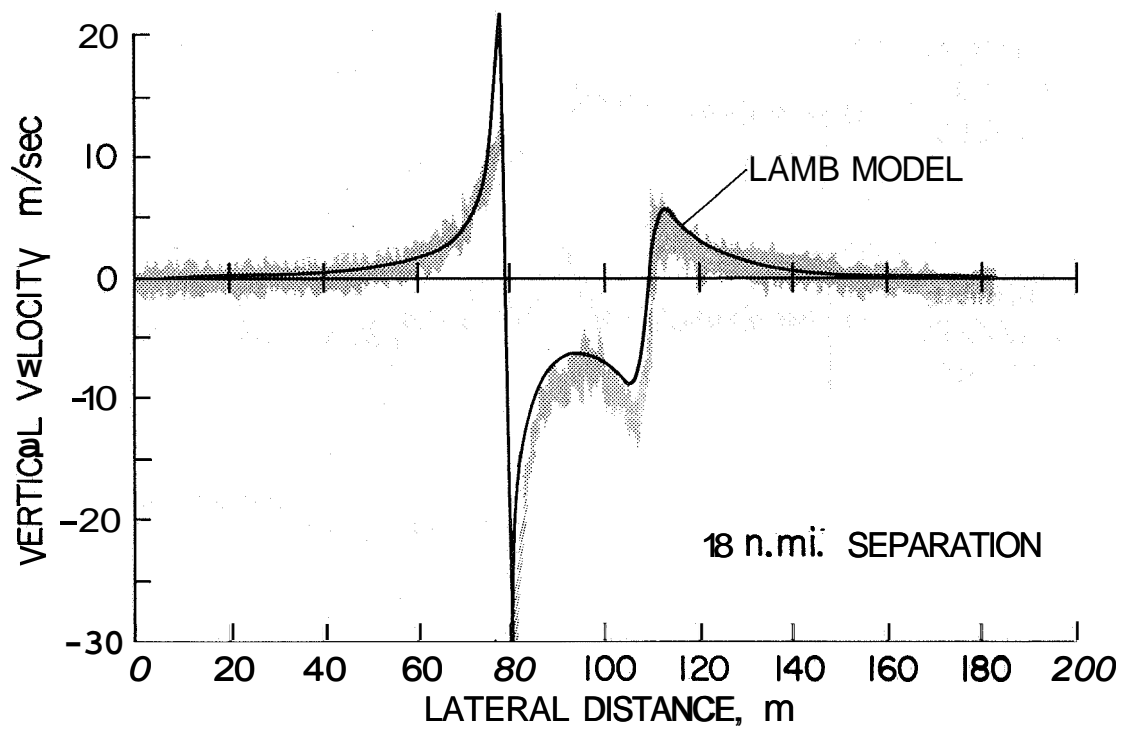

Figure 20.- Vertical velocity distribution measured along the probe aircraft flight path in the wake of a B-727 in takeoff configuration compared to the results of a mathematical model. of a Lamb vortex pair matched to the data.

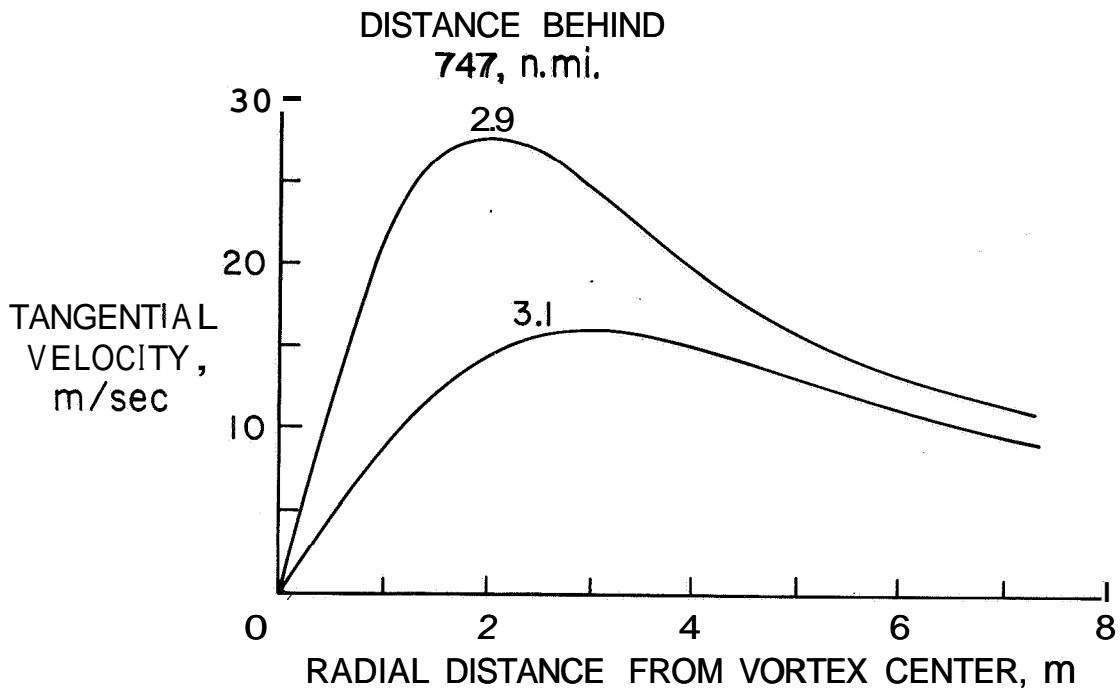

Figure 21.- Decay of a vortex in the wake of a B-747 in landing configuration as indicated by a Lamb vortex model matched to the measured velocities.

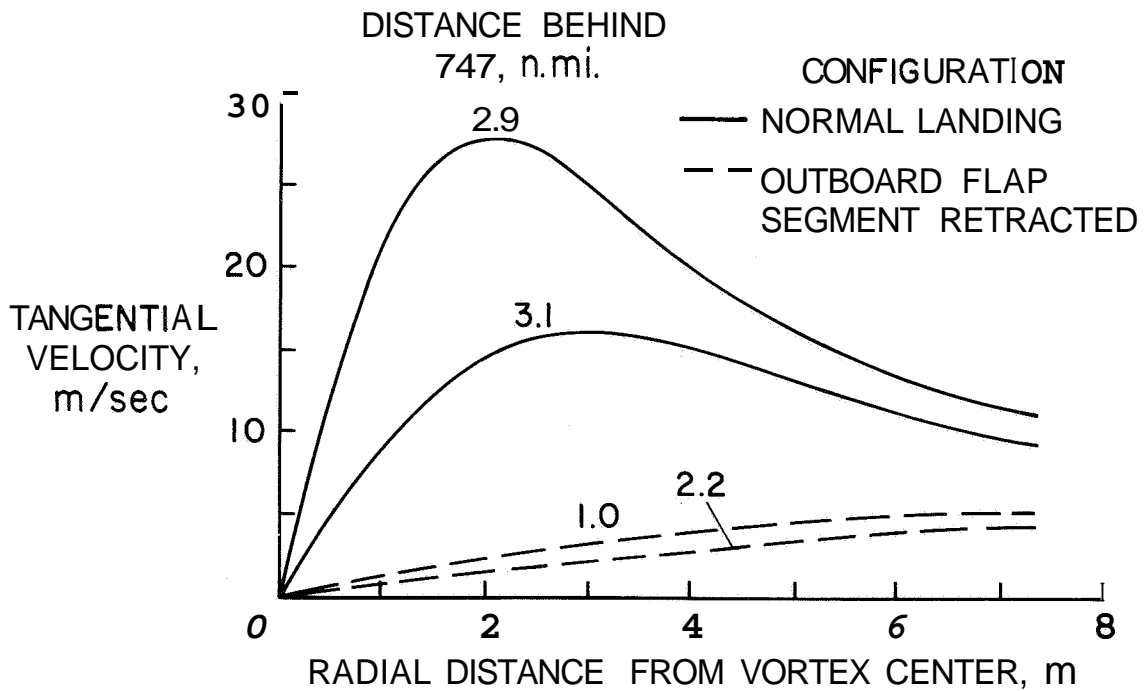

Figure 22.- Alleviation of the velocities in the wake of a B-747 resulting from retraction of the outboard flap segment as indicated by a Lamb vortex model matched to the measured velocities.