

HIGH PRESSURE ROTARY PISTON COAL FEEDER

J. F. Gardner

U. S. Energy Research and Development  
Administration, Morgantown Energy Research  
Center  
Morgantown, West Virginia

H. T. Gencsoy

West Virginia University  
Morgantown, West Virginia

D. C. Strimbeck

U.S. Energy and Research and Development  
Administration, Morgantown Energy Research  
Center  
Morgantown, West Virginia

## ABSTRACT

This feeder concept uniquely combines the functions of solids feeding, metering, and pressurization into one compact system. Success with the rotary-piston concept would provide a lower-cost alternative to lock-hopper systems.

The rotary-piston coal feeder was conceived at MERC. Initial design of the feeder was accomplished by WVU personnel under contract to ERDA. The design of the feeder is presented, with special emphasis on the difficult problem of seal design. Initial tests will be to check seal performance. Subsequent tests will evaluate solids-feeding ability.

## HIGH PRESSURE ROTARY PISTON COAL FEEDER

by

J. F. Gardner<sup>1</sup>, H. T. Gencsoy<sup>2</sup>, and D. C. Strimbeck<sup>3</sup>INTRODUCTION

An important step in all gasification processes is the feeding of coal from atmospheric pressure into gasifiers operating at pressures up to 1500 psig. The ultimate objective of this work is a coal feeder with discharge capabilities of 1500 psig and 350°F. The critical design problems are the rotary-piston mechanism, and lubrication, wear and sealing of feeder components. A two-step design procedure thus was followed.

The basic mechanisms of a rotary feeder were first developed. Consideration then was given to sealing, wear, and lubrication. The initial design is for 100 psig discharge pressure at 300°F, with a feed capacity of 200 to 1000 pounds per hour. Design problems associated with the rotary feeder must be solved at these modest conditions before higher pressures and flows can be achieved.

This design work was done in Phase I, the first year of a three-year research program supported by ERDA at West Virginia University. The design work is covered in this paper. Phase II consists of fabrication and testing of the prototype pump. Phase III will extend the design to 1500 psig with feed rates of several tons of coal per hour.

---

<sup>1/</sup> Mechanical Engineer, U.S. ERDA -- Morgantown Energy Research Center, Morgantown, WV.

<sup>2/</sup> Professor, Mechanical Engineering & Mechanics, West Virginia University, Morgantown, WV

<sup>3/</sup> Chemical Engineer, U.S. ERDA -- Morgantown Energy Research Center, Morgantown, WV.

## ROTARY PISTON COAL FEEDER

### Feeder Operation

Assembly drawings of the rotary piston coal feeder are shown in Figures 1 & 2. The main parts are an outer casing with an inlet hopper and a discharge opening, a rotating (hollow) disk assembly with a thin rim containing the injection chamber, piston and rod, and a drive shaft assembly. The reciprocating action of the piston is provided by two fixed conjugate cams secured to the outer casing and two roller followers attached to the piston.

The feeder operates as follows. Coal fills the open piston cylinder at top dead center ( $0^\circ$ ). The piston position then remains constant as the piston and its rotating housing moves clockwise through an angle of  $135^\circ$ . During the next  $75^\circ$  of rotation, the piston is driven radially outward by the contact between the cams and followers. The coal empties by gravity through the discharge. During the next  $60^\circ$  of rotation, the piston dwells at the maximum outward position. The piston then returns to the loading position during the next  $70^\circ$  of rotation. The piston then dwells in this retracted position for the final  $15^\circ$  of rotation prior to charging with coal.

The rotating disk is driven by an electric motor through a speed reducer at rates up to 30 rpm. This will provide a feed rate of approximately 1200 lb/hr ( $\rho = 30 \text{ lb/ft}^3$ ) for finely crushed coal.

### Basic Feeder Components

The distinguishing feature of this feeder is a rotating disk containing the injection chamber, and a cam-activated reciprocating piston which provides the pumping action for feeding the coal particles into

a chute against the discharge pressure. The following are brief descriptions of some of the main feeder components.

#### The Rotating Disk and Piston Assembly

The heart of the rotary-piston coal feeder is the internal rotating disk to which many of the internal parts are supported or connected. The input rotational energy is directly transferred to the disk through the drive shaft, causing the disk to rotate inside the outer casing on two 27-inch outside-diameter ball bearings. With the disk rotating, the cam followers, which are attached to the piston rod, roll along the fixed cam profiles, imparting a reciprocating motion to the piston. This action causes the coal to discharge, and then allows the piston to retract for refilling.

Design of the rotating disk provides sufficient rigidity for proper installation of the large diameter ball bearings, input drive shaft, and other internal parts. The rotating disk is a thin cylindrical shell which is closed at one end. The disk is one piece cast steel construction with all support areas cast integrally with the disk. The interior of the disk is sealed from the high pressure gases at the discharge area.

The rotating disk supports the piston rod at two locations with linear ball bearings. This arrangement reduces friction losses and assures perfect alignment of the piston in the cylinder during operation. A rolling diaphragm at the piston head prevents coal particles from entering the interior of the rotating disk. The diaphragm also seals against high pressure gases when the piston cylinder is discharging coal. For added sealing protection, rod seals and wiper rings are fitted into machined grooves in the area directly below the cylinder bore of the rotating disk.

### The Outer Casing

The outer casing consists of two semi-circular cylindrical shells joined at the center with casing bolts, and two circular end plates. The outer casing contains the inlet at the top, and the discharge is attached at the bottom. Wear compensating seals are located around these openings on the outer casing to keep high pressure gas and coal particles from penetrating to the inside of the feeder and contaminating the rotating disk and its feeding mechanism.

### Cams and Cam Followers

The reciprocating action of the piston is caused by two fixed conjugate cams attached to the cam side end-plate. Two cam followers secured to the piston rod ride on the cam profile of the rotating disk, providing the forward and backward strokes of the piston in the cylinder. The cam profiles are specially designed to impart a simple harmonic motion to the piston, with a 2-inch stroke and a maximum pressure angle of 30°.

The cam followers are mounted eccentrically on the studs. This provides a preload between the followers and cam surface to ensure constant contact.

### Large Diameter Ball Bearings

Two 27-inch O.D. Ball bearings support the rotating disk at both ends in the outer casing. This assures low friction loss, and minimizes deflection and bearing problems associated with the drive shaft. This arrangement also aligns the rotating disk in the outer casing, and thus maintains seal dimensions around the inlet and discharge openings.

### Coal Feeder Seals

Sealing problems associated with this feeder design are unusual and challenging. Effective sealing of the piston and rod when facing the high pressure discharge is achieved by the rolling diaphragm in the piston head, and the combination of the seal and wiper rings in the rod, as discussed previously.

Seals between the outer casing and the rotating disk at the inlet and discharge openings had to be specially designed. Commercially available products could not be used. Three types of wear compensating seals were designed for the inlet and discharge openings. The basic ideas behind these designs can be seen in Figures 3 and 4. The principal parts in the wear compensating seals consist of a primary seal nose contacting the rotating disk along the periphery of the discharge opening, and a secondary seal supporting the primary seal with adjustable pre-load elements. A pressure gap is incorporated in all these seals between the seal g. and seal nose back surface. The pressure of surrounding gases thus helps to force the seal against the rotating disk and make the contact area leak-proof. Wear is also automatically compensated by the deflection of the seal lip to provide long life for the seal. The seals are also designed for easy accessibility and maintenance.

The three seal assemblies are being built. The three assemblies principally consist of a primary seal nose and a secondary seal. Three different seal materials, i.e. EPDM rubber, polyimide carbon composite and Teflon, bonded onto an epoxy glass fabric laminate, will be used for the primary seals. All three secondary seals will be made from EPDM rubber. The materials selected for the test seals are thought to

be the most compatible with the chemical, thermal and wear requirements for the coal pump. These seals will be tested on a feeder prototype being built at the ERDA, Morgantown Energy Research Center, Morgantown, West Virginia.

A Teflon fiber gasket tape is used as a gasket between the outer casing shell and end plates. The tape has excellent durability and sealing characteristics and is easily installed. The large end bearings are also protected from contamination by a bearing seal strip snap fitted into a groove machined in the outer casing.

#### SUMMARY

The feeder design consists of a rotating disk in a cylindrical feed chamber containing a reciprocating piston. The piston seals the feed chamber after the coal is dumped into a reactor vessel so that there is no loss of gas from the reactor. These are the only moving parts in the feeder, and their rugged construction should present minimum wear problems.

This feeder is designed for 1200 pounds per hour, operating at 30 rpm. The body of the feeder is 27 inches in diameter and 12 inches wide. The compact design makes it possible to use more than one feeder in parallel to get higher coal feed rates. Higher values of rotational speed could also increase the feed capacity. The drive requirement of a single unit at 30 rpm is 5.3 horsepower.

The coal pump is all-steel construction using commercially-available standard parts wherever possible. The design consists of a minimum number of parts that can be easily manufactured and assembled to provide a reliable unit.



A diaphragm seal in the piston head, and a combination of seal and wiper rings in the rod, provide effective sealing of the coal discharge. Seals between the outer casing and the rotating disk at the inlet and discharge openings, however, present challenging design situations requiring special solutions. Three types of wear-compensating seals of various configurations thus were conceived. These seals are being fabricated. They will be tested on a prototype feeder which is currently being made at ERDA facilities in Morgantown, West Virginia.

Success with this coal feed concept will lower the cost and difficulty of pressurizing, metering, and injecting coal into a reactor vessel. The feeder thus could replace lock-hopper feed systems now in general use, including the valves in such systems that are a source of many problems.

If the Phase II tests of the seals succeeds, this work will be extended into Phase III. This phase would be to design a coal feeder for the 1,500 psig pressure required for commercial coal conversion plants.

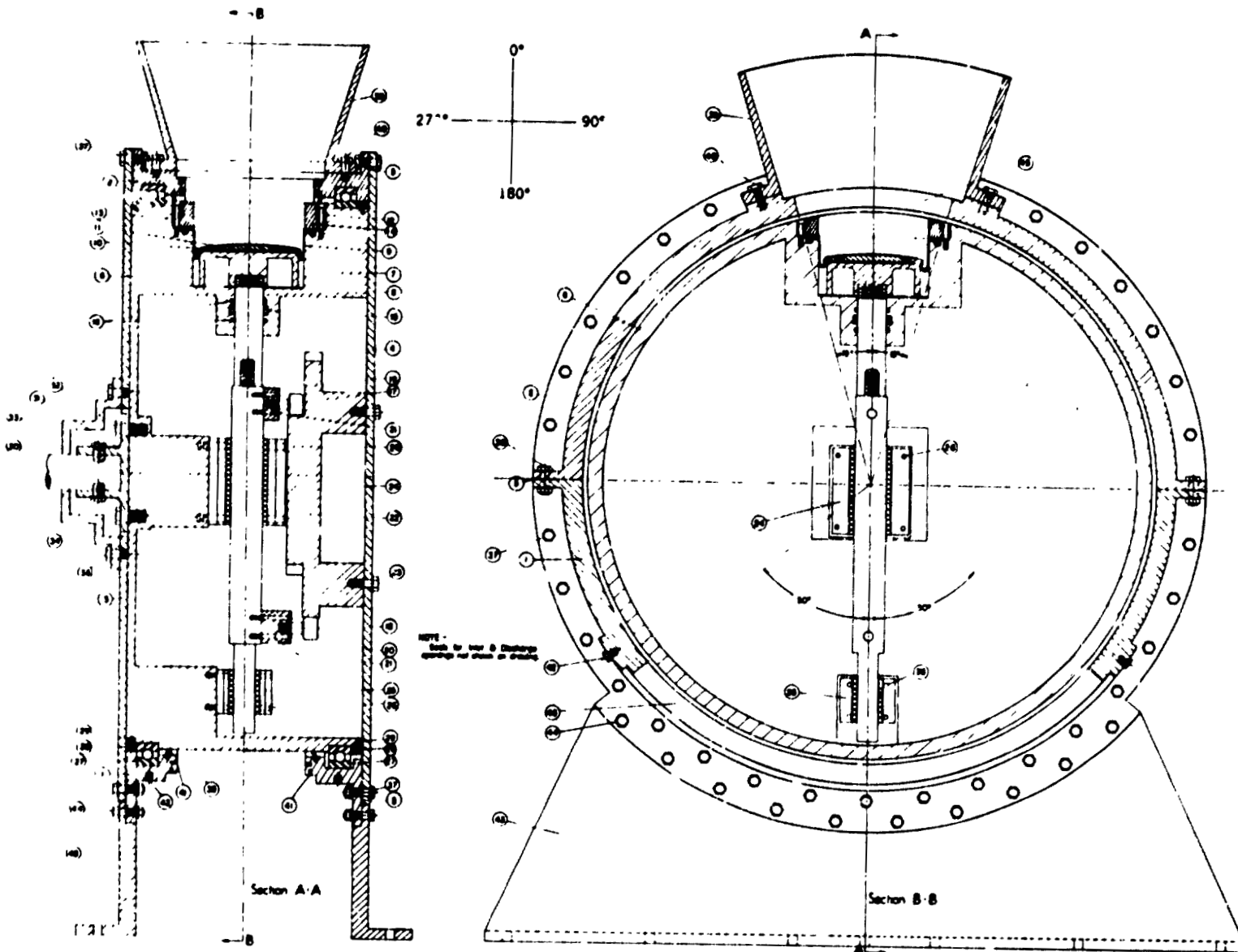

FIGURE 1 - ASSEMBLY OF HIGH PRESSURE ROTARY PISTON COAL FEEDER

ORIGINAL PAGE IS  
OF POOR QUALITY

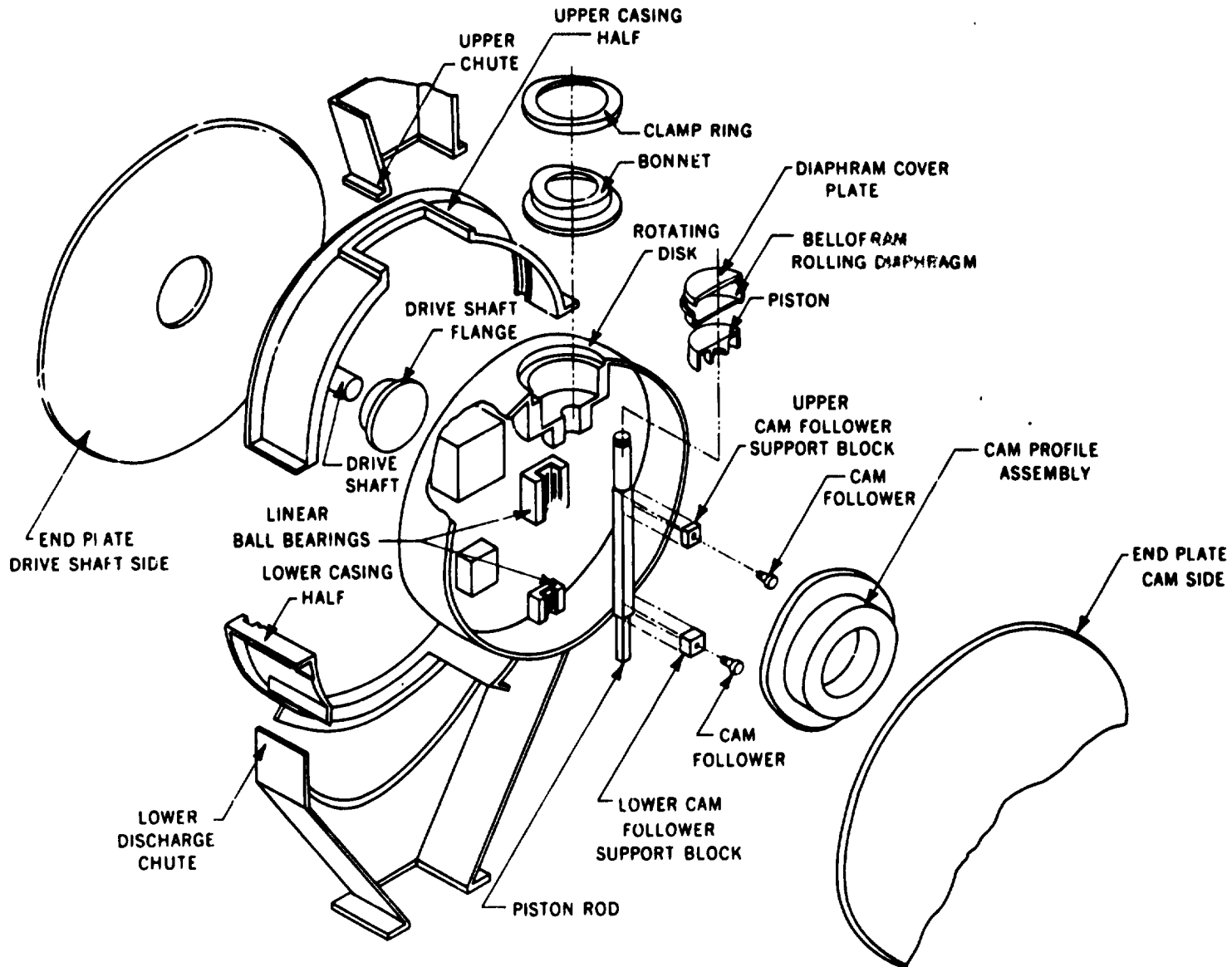
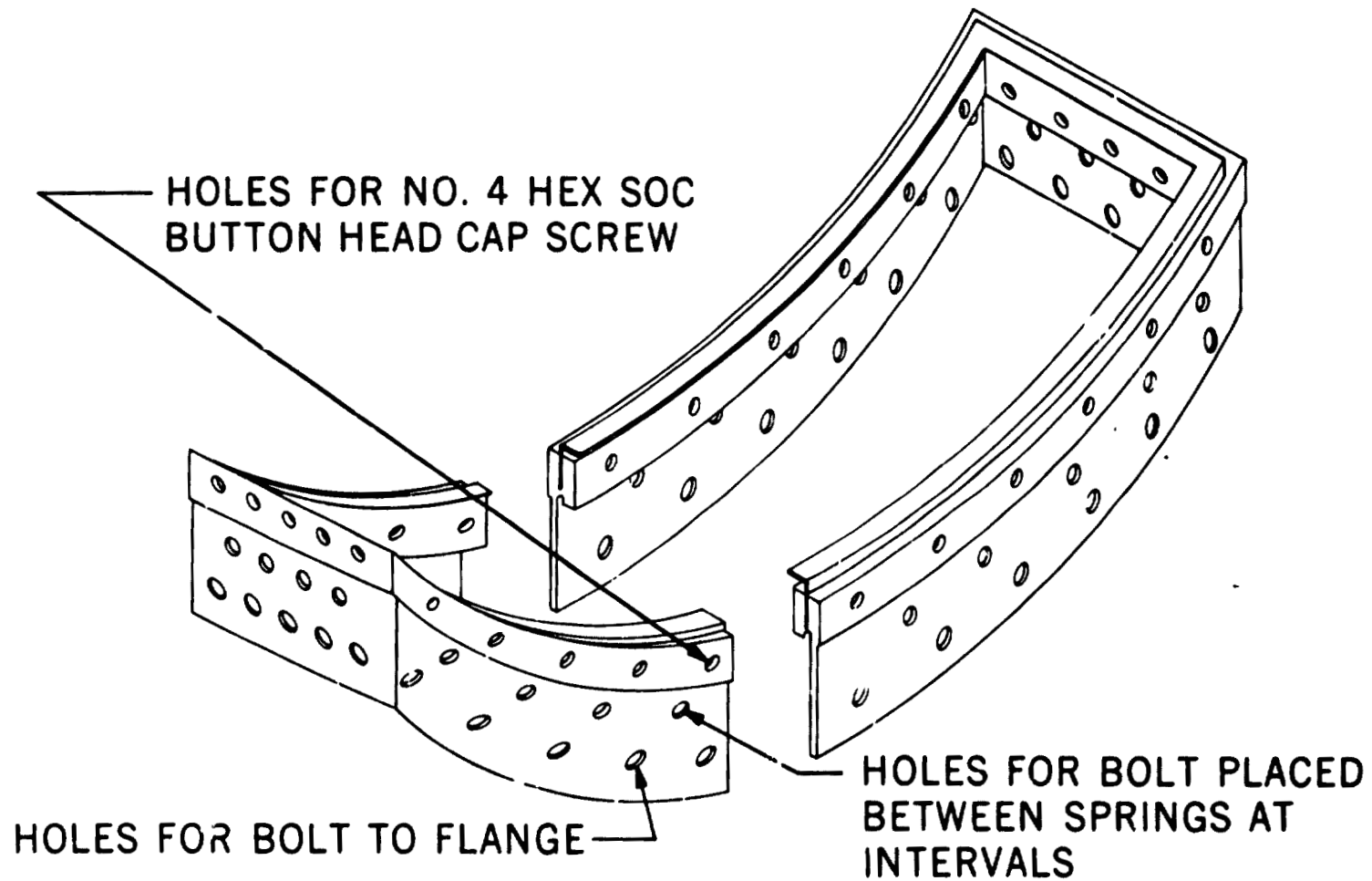

FIGURE 2. - EXPLODED ASSEMBLY OF HIGH PRESSURE ROTARY PISTON COAL FEEDER



**FIGURE 3-SEAL ASSEMBLY FOR HIGH PRESSURE  
ROTARY PISTON COAL FEEDER**

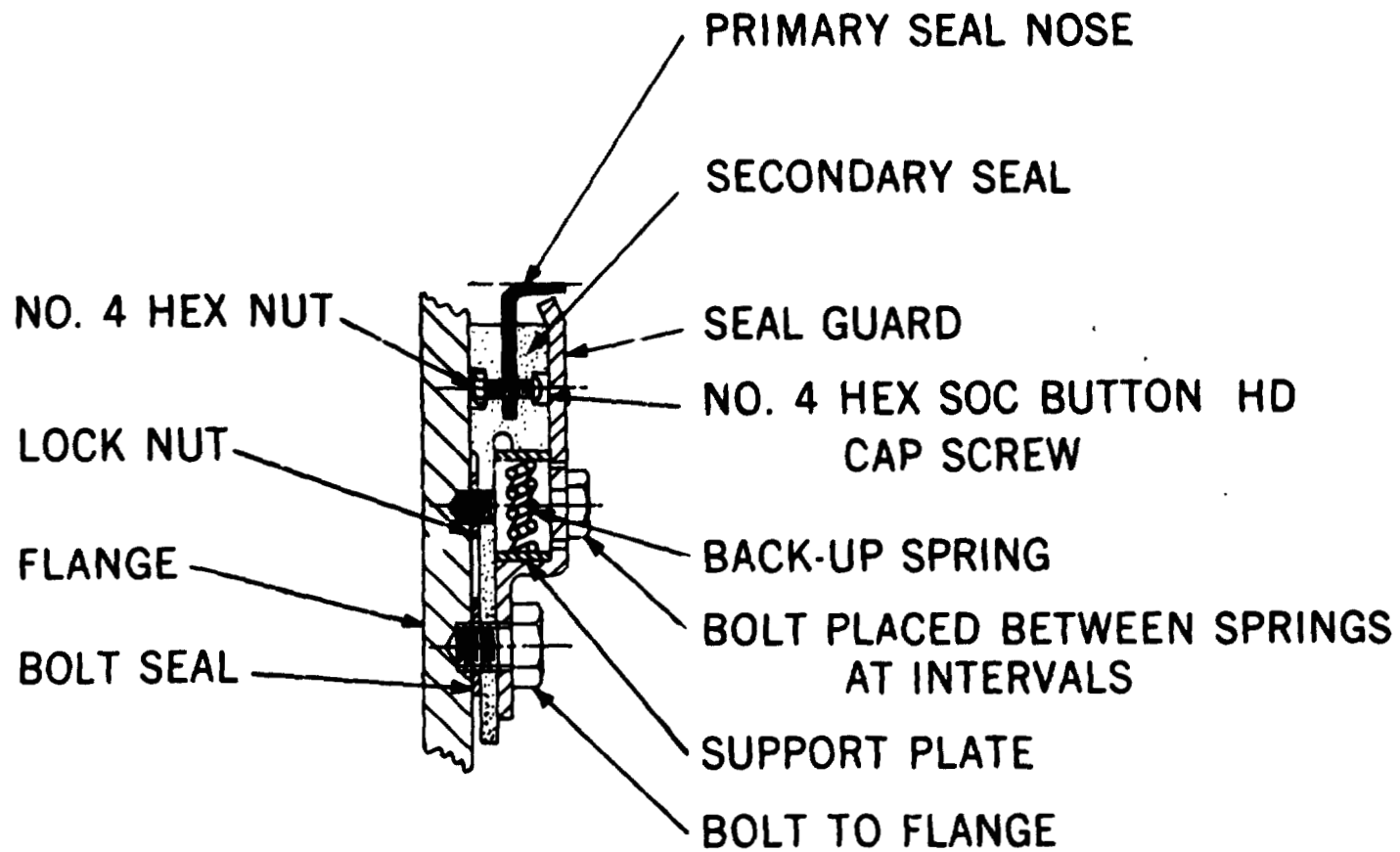

FIGURE 4 - SEAL ASSEMBLY