

N78

19032

UNCLAS

PRECEDING PAGE BLANK NOT FILMED

10
N78-19032

An Application of Interactive Computer
Graphics Technology to the Design
of Dispersal Mechanisms

by

B. J. Richter and B. H. Welch
Lockheed Missiles & Space Company, Inc.
Sunnyvale, California

ABSTRACT

Interactive computer graphics technology is combined with a general purpose mechanisms computer code to study the operational behavior of three guided bomb dispersal mechanism designs. These studies illustrate the use of computer graphics techniques to discover operational anomalies, to assess the effectiveness of design improvements, to reduce the time and cost of the modeling effort, and to provide the mechanism designer with a visual understanding of the physical operation of such systems.

INTRODUCTION

A general purpose mechanisms computer code has been developed that accurately simulates complex interactive dynamic behavior between the various components, which comprise mechanisms. Mechanism components that can readily be accommodated with this new simulation technique are exemplified by rollers, nonlinear springs and dampers, linkages, actuators, and arbitrary constraint guides. In addition, mechanical components that collide, rebound, slide relative to one another, and which are subjected to complex environmental loadings, can be modeled with this code.

Guided bomb systems for dispersing large numbers of submunitions belong to a class of mechanisms for which the mutual interactions between components are geometrically complex, numerous, and depend upon initial conditions and external environmental

loading. For these dispersal systems all of the possible interactions between the various components cannot be determined a priori and consequently must be calculated during the dynamic process. Adequate assessment of motions and reactions for this class of mechanisms is greatly facilitated by an interactive, visual, incremental-in-time solution technique. The problem is initiated on the computer using known conditions. By viewing the subsequent transient response via computer graphics, a previously unforeseen interaction between mechanism components is detected. At such time the problem is stopped, the new interaction is incorporated into the model, and the problem is restarted. This incremental process continues for the desired time of interest.

The following sections discuss three guided bomb dispersal systems whose basic operation is similar. At a predetermined time, the vehicle is pyrotechnically severed into a nose section, a tail section, a payload section, and three cover panels. The dispersion of these components may be forced (e.g., internal pressurization of the vehicle simultaneous to the pyrotechnic cutting charge), or may be due solely to aerodynamic forces.

FIRST DISPERSAL SYSTEM

As a first step in analyzing the dynamics of a guided bomb dispersal system, the computer graphics technique can be used to visually locate specific areas of potential collisions between components. This is accomplished by performing an initial analysis in which no impacts are included in the model, thus allowing bodies to pass through one another. For the system depicted in Figure 1, operating with a given set of flight conditions, it is found that: (1) the aft surface of the nose section will impact/slide over the forward part of the payload section, (2) the aft tip of the winged, upper cover panel will impact/slide along the cylindrical surface of the tail section, and (3) one of the side cover panels initially moves radially away from the payload section but then returns to impact it. The areas that have been identified can then be modeled to simulate the forces generated by such impacts and the analysis can be rerun as shown in Figure 2. This approach results in a great savings of both man-time and computer time by eliminating the need to model the entire structure to account for all possible impacts.

Even though a side cover panel impacts the payload section in the example shown in Figure 2, the deployment of the payload is not seriously impaired. Under other flight conditions, however, the behavior of this system was found to be totally unacceptable. Figure 3 illustrates a case in which the winged, upper cover panel is aerodynamically 'trapped' against the payload section prohibiting successful deployment of the payload. To avoid this anomalous behavior, the only practical design fix was to restrict the operation of this system to certain vehicle angles of attack.

SECOND DISPERSAL SYSTEM

The example shown in Figure 4 is intended to illustrate two important aspects of using computer graphics techniques to study dispersal systems. The first thing to be noted is that two views of the dispersal sequence are necessary to comprehend the relative positions of the various components. In this particular case, the nose section happens to pass through the developing pattern of payload bodies untouched. Under slightly different flight conditions it can be expected that the nose section will impact several of these payload bodies. The design modification which was proposed to prevent this anomaly consisted of rigidly connecting the nose and tail sections of the vehicle via a center post. A combined nose/tail section was found to pitch much slower than the original separate nose section thus easily avoiding impacts with the payload bodies. This design solution was suggested by viewing the sequential pictures shown in Figure 4. Hence, the second thing to be noted is that the computer graphics technique can serve as a visual aid inspiring solutions to operational anomalies.

THIRD DISPERSAL SYSTEM

An example of a more complex dispersal system is illustrated in Figure 5. A side view of the entire system prior to deployment is shown in Figure 5a while in Figure 5b the three cover panels and the payload bodies have been removed to point out that the four tail fins are attached only to the tail cylinder and are cantilevered out over the

cover panels with a small radial clearance or gap. Each of the tail fins is assembled to the tail cylinder by fitting a tab into a mating slot on the tail cylinder as illustrated in Figure 5c. The tab is then secured in the slot by a single break bolt.

This system was originally intended to operate as follows:

- the nose section, tail section, and cover panels are pyrotechnically severed
- a simultaneous pressurization of the payload section drives the cover panels and the payload bodies outward
- the cover panels impact the cantilevered portion of the tail fins, prying them away from the tail cylinder and failing the break bolts (see Figures 5d and 5e)
- the four loose tail fins are then pushed out of the way by the cover panels allowing the payload pattern to develop

When this system was analyzed with the computer graphics technique as shown in Figure 6, it was found that the forces required to fail the break bolts retarded the deployment of the cover panels to such an extent that many impacts occurred between the payload bodies and the cover panels. To correct this malfunction, a relatively simple design modification was proposed which consisted of substituting pyrotechnic bolts for the break bolts which attach the tail fins to the tail cylinder. This allows the tail fins to be severed and aerodynamically carried away from the parent vehicle just prior to the dispersal event. The deployment of the cover panels and payload bodies can then be conducted without anomalous impacts.

CONCLUSIONS

The merging of mechanisms technology with computer graphics technology has provided the designer of guided bomb dispersal systems with a valuable tool for use throughout the entire design process. Specific examples have been discussed which illustrate the use of computer graphics techniques to discover potential design anomalies, to aid in making design improvements, to reduce the time and cost of the modeling effort, and to provide the mechanism designer with a visual understanding of the physical operation of such systems.

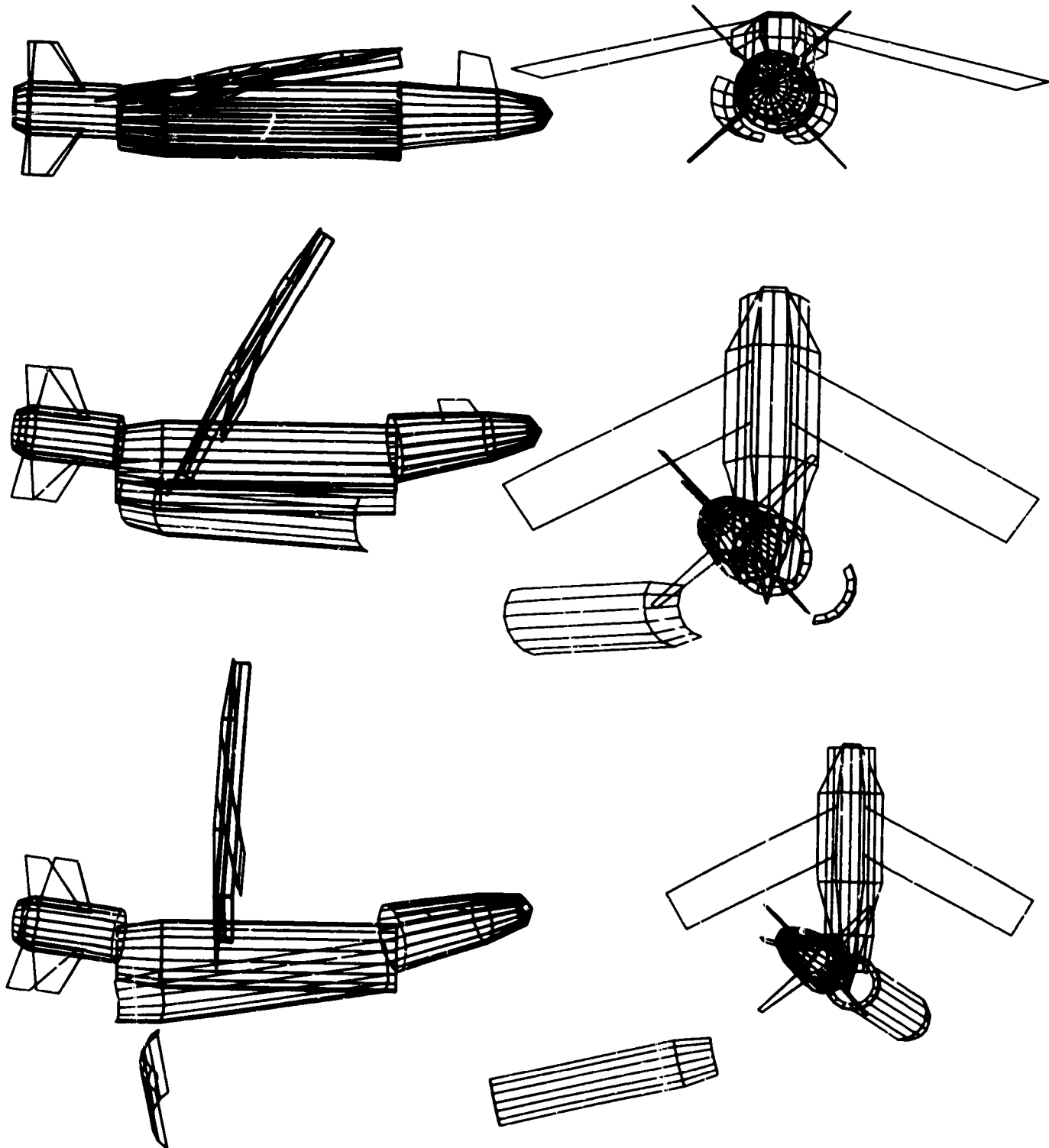

Figure 1. First Separation System
Modeled With No Impacts

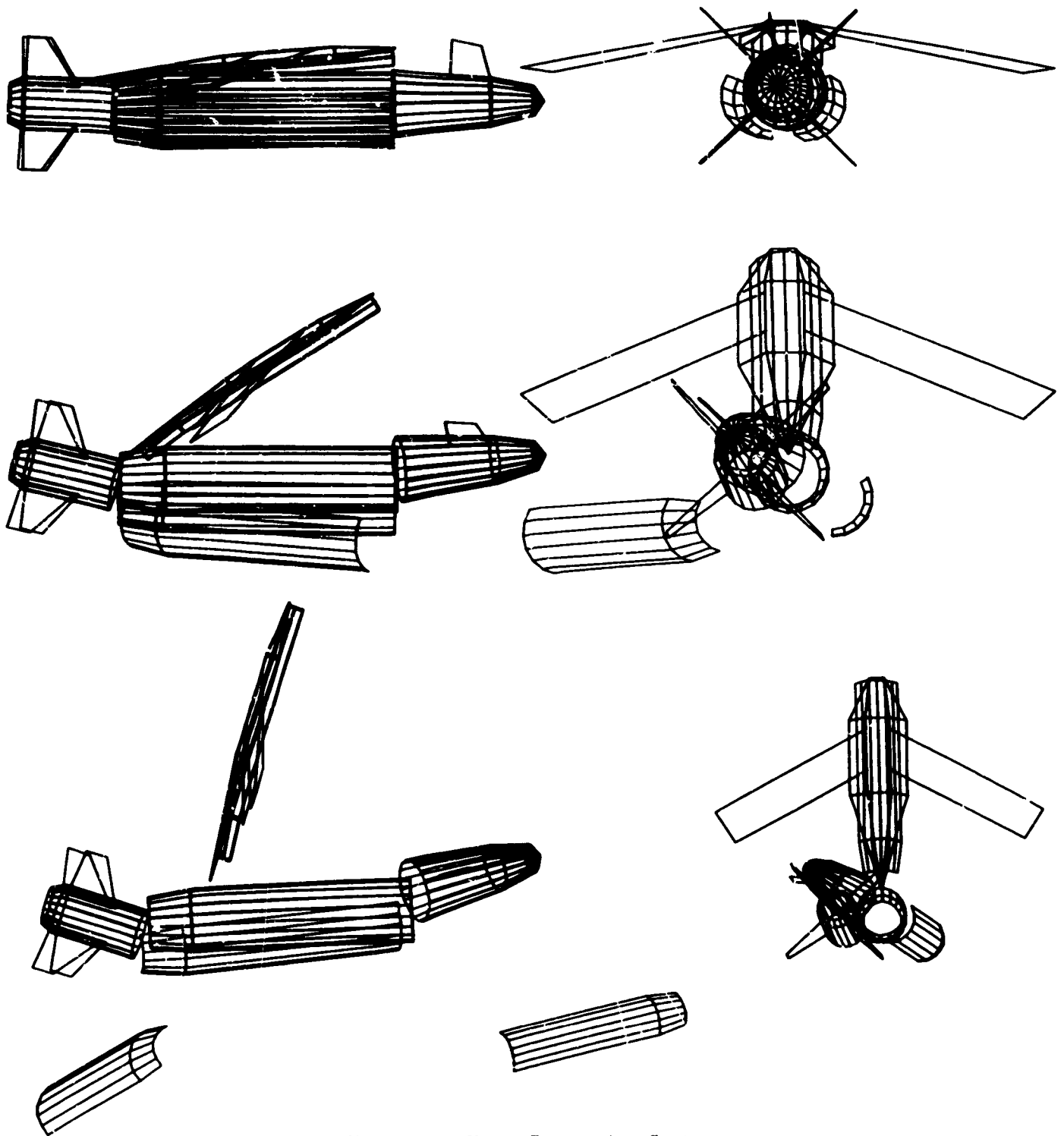

Figure 2. First Separation System
Modeled With Impacts

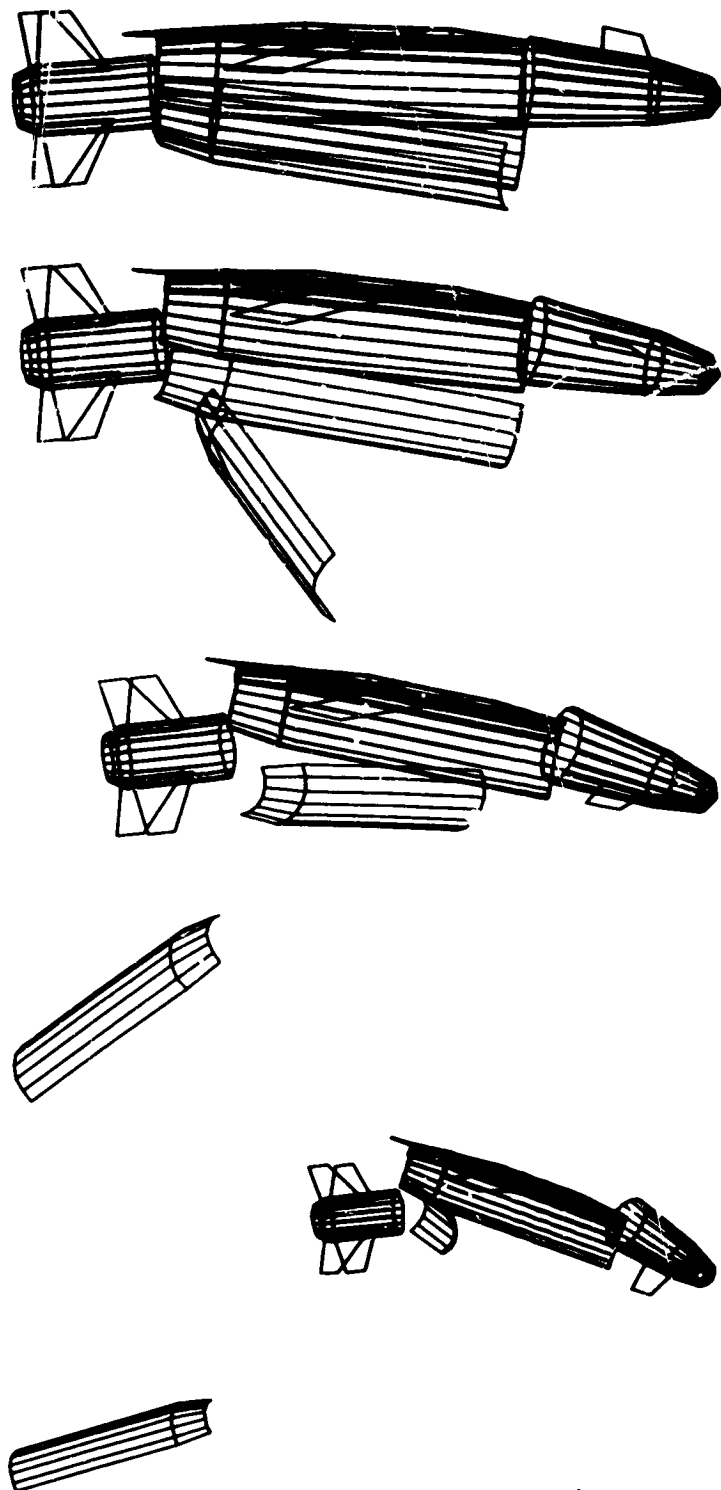

Figure 3. Anomalous Behavior
of First Separation System

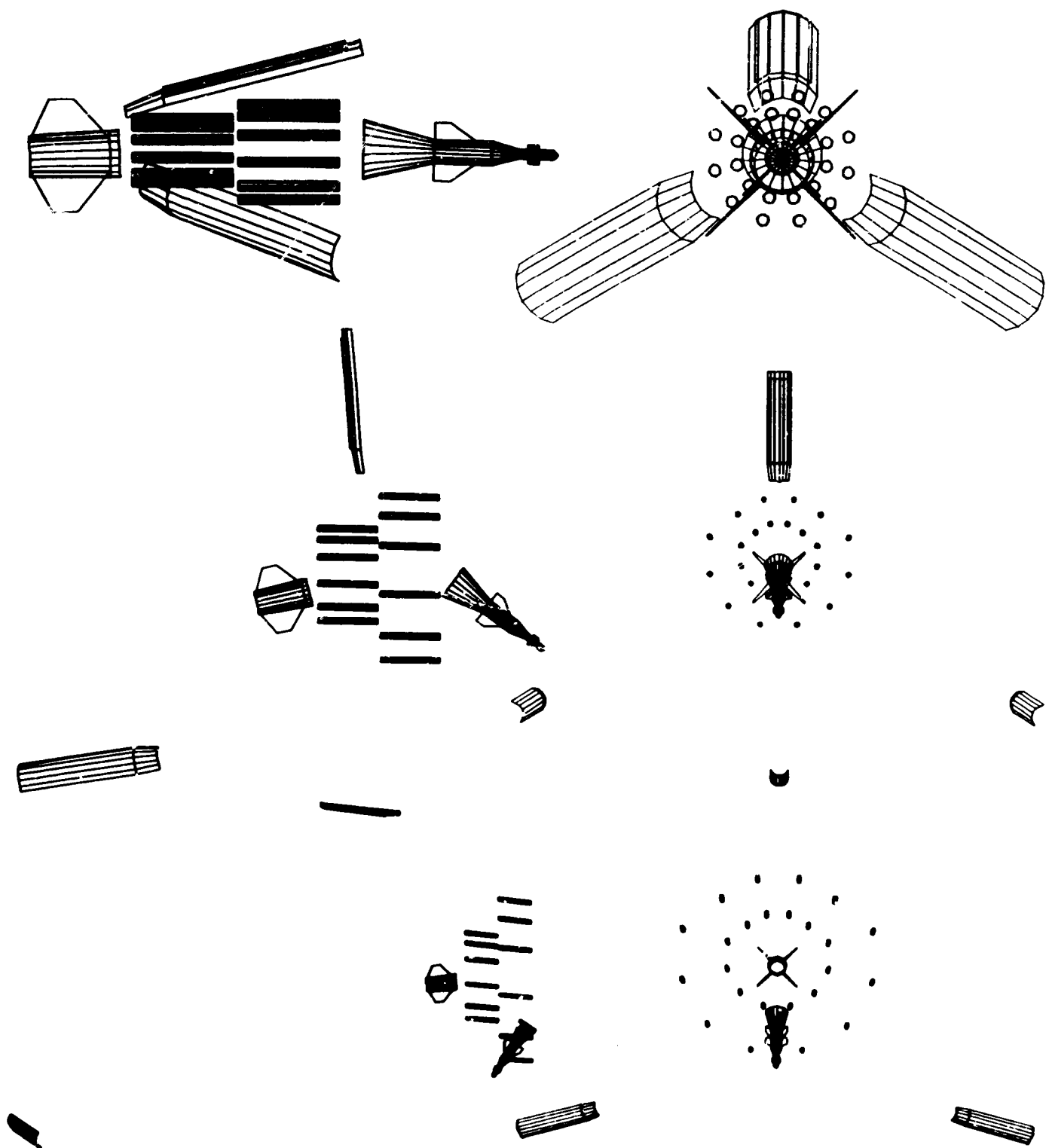

Figure 4. Second Separation System

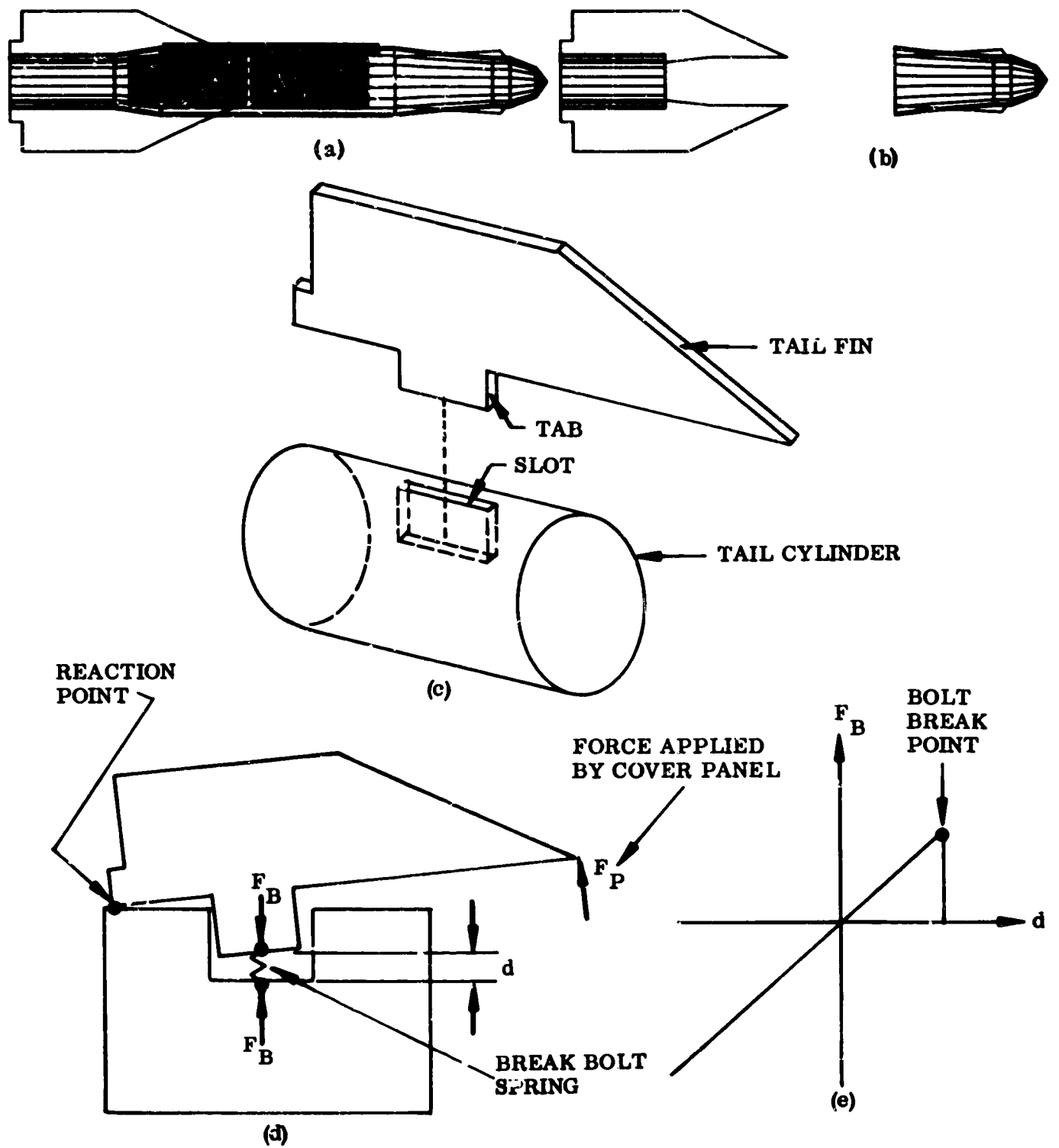

Figure 5. Details of Third Separation System

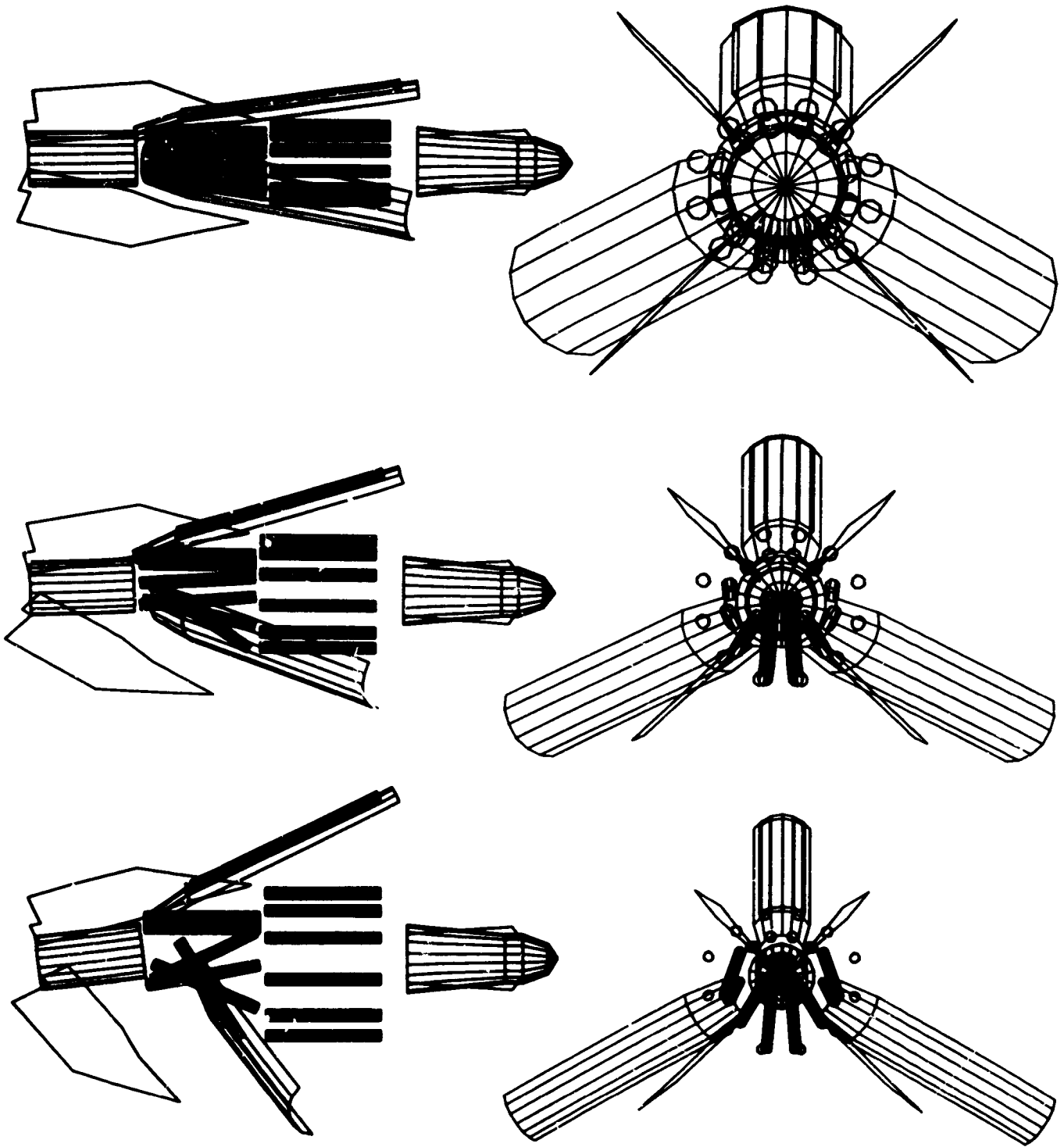

Figure 6. Side View and End View of Deployment Sequence for the Third Separation System

N78

19033

UNCLAS