

(NASA-CR-151749) ORBITER N79-12741
MULTIPLEXER-DEMULTIPLEXER (MDM)/SPACE LAB. THRU
BUS INTERFACE UNIT (SL/BIU) SERIAL DATA N79-12743
INTERFACE EVALUATION, VOLUME 2 Final Test Unclas
Report (Lockheed Electronics Co.) 107 p HC G3/60 26080

JSC-13906

INTERNAL NOTE 78-EG-5

ORBITER MULTIPLEXER-DEMULTIPLEXER (MDM)
SPACE LAB BUS INTERFACE UNIT (SL/BIU)
SERIAL DATA INTERFACE EVALUATION FINAL TEST REPORT

Volume II

PREPARED BY

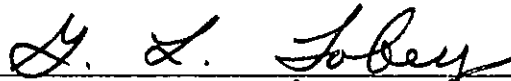

G. L. Tobey, Engineer
Lockheed Electronics Company, Inc.

REVIEWED BY



W. E. Mallery, Subsystem Manager
Multiplexer Demultiplexer

APPROVED BY

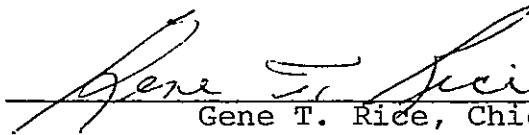

Gene T. Rice, Chief
Data Systems Branch



R. G. Chilton, Chief
Control Systems Development Division

Control Systems Development Division
Engineering and Development Directorate

National Aeronautics and Space Administration
Lyndon B. Johnson Space Center
Houston, Texas

May 1978

LEC-11949

ATS-25173

CR157749

JSC-13906

JUN 26 1978

CONTROL SYSTEMS DEVELOPMENT DIVISION

INTERNAL NOTE 78-EG-5

PROJECT SPACE SHUTTLE

ORBITER MULTIPLEXER-DEMUTIPLEXER (MDM) /
SPACE LAB BUS INTERFACE UNIT (SL/BIU)
SERIAL DATA INTERFACE EVALUATION FINAL TEST REPORT

Volume II



National Aeronautics and Space Administration
LYNDON B. JOHNSON SPACE CENTER

Houston, Texas

May 1978

LEC-11949

| | | | |
|---|--|---|--------------------------------|
| 1 Report No JSC-13906 | 2 Government Accession No | 3 Recipient's Catalog No | |
| 4 Title and Subtitle Orbiter Multiplexer-Demultiplexer (MDM)/Space Lab Bus Interface Unit (SL/BIU) Serial Data Interface Evaluation Final Test Report | | 5 Report Date May 1978 | 6 Performing Organization Code |
| | | 8 Performing Organization Report No LEC-11949 | |
| 7 Author(s) G. L. Tobey | | 10 Work Unit No | |
| 9 Performing Organization Name and Address Lockheed Electronics Company, Inc. 1830 NASA Road 1 Houston, Texas 77058 | | 11 Contract or Grant No NAS 9-15200 | |
| | | 13 Type of Report and Period Covered Internal Note | |
| 12 Sponsoring Agency Name and Address Lyndon B. Johnson Space Center National Aeronautics and Space Administration Houston, Texas 77058 | | 14 Sponsoring Agency Code | |
| | | 15 Supplementary Notes | |
| 16 Abstract Tests were performed to evaluate the operating characteristics of the interface between the Space Lab Bus Interface Unit (SL/BIU) and the Orbiter Multiplexer-Demultiplexer (MDM) serial data input/output (SIO) module. Volume I provides test objectives, test descriptions, as-run test procedures, tabulated test data, and conclusions. Volume II contains the test equipment preparation procedures and a detailed description of the Nova/Input Output Processor Simulator (IOPS) software used during the data transfer tests to determine word error rates (WER). | | | |
| 17 Key Words (Suggested by Author(s)) | | 18 Distribution Statement | |
| 19 Security Classif (of this report) Unclassified | 20 Security Classif (of this page) Unclassified | 21 No of Pages 107 | 22 Price* |

*For sale by the National Technical Information Service, Springfield, Virginia 22161

ACKNOWLEDGMENTS

This document was prepared by Lockheed Electronics Company, Inc., Systems and Services Division (LEC/SSD), Houston, Texas, for the Control Systems Development Division (CSDD) at the Lyndon B. Johnson Space Center (JSC) under contract NAS 9-15200, Job Order 34-259. It was written by G. L. Tobey, Engineer, and approved by C. R. Murdock, Job Order Manager of the Power and Data Systems Engineering Section, and by Swan Person, Manager of the Control Systems Development Department, Lockheed Electronics Company, Inc.

PART A
TEST PROCEDURES

PART A CONTENTS

| Section | Page |
|--|------|
| 1. GENERAL. | 1-1 |
| 2. OBJECTIVE. | 2-1 |
| 3. TEST REQUIREMENTS. | 3-1 |
| 3.1 <u>TEST ARTICLE EQUIPMENT</u> | 3-1 |
| 3.2 <u>FACILITY EQUIPMENT</u> | 3-1 |
| 3.3 <u>TEST SOFTWARE</u> | 3-3 |
| 4. BASELINE DATA TRANSFER TEST. | 4-1 |
| 4.1 <u>TEST DESCRIPTION</u> | 4-1 |
| 4.2 <u>TEST PROCEDURE</u> | 4-1 |
| 5. RISE TIME, AMPLITUDE, AND OFFSET VARIATION TEST. | 5-1 |
| 5.1 <u>TEST DESCRIPTION</u> | 5-1 |
| 5.2 <u>TEST PROCEDURE</u> | 5-1 |
| 6. VARIATION OF SERIAL DATA AMPLITUDE TEST. | 6-1 |
| 6.1 <u>TEST DESCRIPTION</u> | 6-1 |
| 6.2 <u>TEST PROCEDURE</u> | 6-1 |
| 7. NOISE TEST | 7-1 |
| 7.1 <u>TEST DESCRIPTION</u> | 7-1 |
| 7.2 <u>TEST PROCEDURE</u> | 7-1 |
| 8. SKEW VARIATION OF SERIAL DATA OUTPUT, DATA WORD DISCRETE, AND MESSAGE SIGNALS. | 8-1 |
| 8.1 <u>TEST DESCRIPTION</u> | 8-1 |
| 8.2 <u>TEST PROCEDURE</u> | 8-1 |
| 9. CABLE LENGTH TEST. | 9-1 |
| 9.1 <u>TEST DESCRIPTION</u> | 9-1 |

| Section | Page |
|---|------|
| 9.2 <u>TEST PROCEDURE</u> | 9-1 |
| 10. COMMON MODE NOISE TEST | 10-1 |
| 10.1 <u>TEST DESCRIPTION</u> | 10-1 |
| 10.2 <u>TEST PROCEDURE</u> | 10-1 |
| Appendix | |
| PROCEDURE FOR SWAPPING I/O MODULES IN THE MDM B/B | A-1 |

TABLE

| Table | | Page |
|-------|--|------|
| 8-1 | DELAY SELECTION SWITCH CHART FOR DBSG DELAY INTERFACE BOARD. | 8-4 |

FIGURES

| Figure | | Page |
|--------|--|------|
| 4-1 | Matra test baseline hardware configuration | 4-2 |
| 4-2 | SIO module assembly for MDM B/B. | 4-3 |
| 4-3 | MDM SIO module dummy loads | 4-6 |
| 4-4 | MBE (RAM model) data pattern for baseline data transfer test. | 4-8 |
| 4-5 | Four MDM SIO cables (SD, WD, MO, and MI) to SL/BIU | 4-9 |
| 5-1 | Rise time, amplitude, and offset variation test configuration. | 5-2 |
| 6-1 | Variation of serial data amplitude test configuration. | 6-2 |
| 7-1 | Matra noise test configuration | 7-2 |
| 7-2 | Noise injection at MDM B/B SD receiver | 7-4 |
| 7-3 | Noise injection at SL/BIU SD receiver. | 7-5 |
| 7-4 | Noise injection at SL/BIU discrete receiver. | 7-6 |
| 9-1 | Matra cable length test configuration. | 9-2 |
| 10-1 | Common mode noise injection circuit. | 10-2 |

ACRONYMS AND ABBREVIATIONS

| | |
|------------|--|
| ac | alternating current |
| A/D | analog to digital |
| AID | analog input, differential (type of IOM) |
| AISE | analog input, single ended (type of IOM) |
| AOD | analog output, differential (type of IOM) |
| B/B | breadboard |
| BIU | Bus Interface Unit |
| BL | baseline |
| CDW | command data word |
| CSDD | Control Systems Development Division |
| CW | command word (data bus word) |
| DBC | data bus coupler |
| DBSG | Data Bus Signal Generator |
| dc | direct current |
| DIP | dual inline package |
| DI5 (DIL) | discrete input, 5 volts (low level) |
| DI28 (DIH) | discrete input, 28 volts (high level) |
| DO5 (DOL) | discrete output, 5 volts (low level) |
| DO28 (DOH) | discrete output, 28 volts |
| E | part of the SEV bits in the response data word (bit 23) |
| ENA | enable |
| ft | foot/feet |
| ICD | Interface Control Document |

| | |
|-----------|--|
| I/O | input/output |
| IOM | Input/Output Module (class of units used in the MDM) |
| IOPS | Input/Output Processor Simulator |
| JSC | Lyndon B. Johnson Space Center |
| kHz | kilohertz |
| LEC/SSD | Lockheed Electronics Company, Inc./Systems and Services Division |
| LED | light emitting diode |
| L-G | line to ground |
| L-L | line to line |
| LSI | Lear Siegler, Inc. |
| MBE | Manual Bus Exerciser |
| MDM | multiplexer-demultiplexer |
| MHz | megohertz |
| MI (MIN) | message in, discrete line (SIO module) |
| MIA | multiplexer interface adapter (interfaces MDM) |
| MO (MOUT) | message out, discrete line (SIO module) |
| mV | millivolt |
| μ F | microfarad |
| μ s | microsecond |
| NRZ | nonreturn to zero |
| pk | peak |
| RAM | random access memory |
| RDW | response data word |
| RMS | root mean square |

| | |
|-----------|--|
| SAIL | Shuttle Avionics Integration Laboratory |
| SCU | Sequence Control Unit (part of the MDM) |
| SD | serial data line (SIO module) |
| SEV | bits 22, 23, and 24 in the response data word |
| SIO | Serial Input Output (type of IOM) |
| SL | Space Lab |
| S/N | signal to noise |
| TBD | to be determined |
| TSP | twisted shielded pair, type of cable used for data bus and SIO module input/output lines |
| WD (WDLN) | word discrete line (SIO module) |
| WER | word error rate |

1. GENERAL

This document describes the test procedures required to evaluate the performance of the Space Lab (SL) Bus Interface Unit (BIU). This level of testing will involve the design evaluation of signal levels, timing, and signal-to-noise (S/N) performance. These tests will be comprehensive in order to provide data on the operational characteristics of the SL/BIU.

The tests defined by this document will be performed in accordance with the Control Systems Development Division (CSDD) Shuttle Vehicle/Space Lab Avionics Development Test Project Plan, January 1977.

The tests will be conducted under laboratory ambient conditions with no hostile environment testing to be done. The tests will generally consist of transmitting fixed blocks of data to the SL/BIU and requesting the data as a response from the Matra SL/BIU. By comparing the two blocks for errors, a performance cross section may be defined for the operation of the SL/BIU.

The Nova Input Output Processor Simulator (Nova/IOPS) will be used to control the data transfer and error logging between the CSDD Multiplexer-Demultiplexer Breadboard Serial Input/Output (MDM B/B SIO) module and the Matra SL/BIU subsystem.

The SIO module will be modified as necessary to perform various tests and still maintain normal operational characteristics. There are four channels in the SIO module. One will be assigned to a Lockheed Electronics Company (LEC) built SIO tester box (utilized for MDM testing), and a second will be assigned to the SL/BIU. The remaining two channels will not be used during the test. Four SIO interface cables will be used per channel for

data transfer. Three will be discretes used to control the timing on the fourth which will be used for bidirectional serial data transfers.

This document depicts "as run" procedures for testing of the interface between the MDM SIO and the SL/BIU to compare the component design characteristics against interface requirements as described in Interface Control Document (ICD) 2-05301, Shuttle Vehicle/Space Lab Avionics Interfaces. The MDM B/B SIO interface shall represent the Orbiter interface during evaluation of the SL/BIU breadboard design.

The hardware test configurations are not data block or software dependent. The general configuration characteristics are to be noted during software test initialization to identify the hardware with a particular hardware configuration and set of parameter characteristics.

2. OBJECTIVE

The evaluation tests described in this document are designed to accomplish the following objectives as a minimum for component level testing of the SL/BIU.

- Determine the baseline operation parameters for comparison to ICD 2-05301 requirements.
- Determine the influence of serial data line parameter variation on the operation of SL/BIU.
- Determine the effects of noise on discrete and serial data lines (S/N ratio).
- Determine the effects of cable length variation.

3. TEST REQUIREMENTS

The testing will be performed to investigate the hardware performance with respect to the critical ICD 2-05301 requirements. In general, interface parameters will be varied over a range of values to determine limits. The test results will be used to evaluate the acceptability of the interface with respect to the ICD performance requirements.

The tests will be performed as described in this document. As each test is conducted, data regarding all relative parameters will be noted and photographs will be taken of the signals involved in that particular test. The data obtained from the hardware parameters and the software error checking will be used to generate a supplemental report with photographs of the various signals associated with each test.

3.1 TEST ARTICLE EQUIPMENT

The minimum test article equipment required for this test program will consist of the following:

- SL/BIU provided by Matra.
- Cable connectors for connection of the four SIO signal lines to the SL/BIU provided by Matra.

3.2 FACILITY EQUIPMENT

The CSDD facility equipment required to conduct the test program will consist of the following:

- Data General Nova 1200/IOPS
- Lear Siegler, Inc. (LSI) ADM-3 Video Terminal
- Okidata Matrix Printer (hardcopy)
- MDM B/B (with SIO module modified for Matra SL/BIU testing)

- Shuttle Avionics Integration Laboratory (SAIL) MDM,
S/N 07187-006050038
- Manual Bus Exerciser (MBE) Random Access Memory (RAM)
Model, LEC Built
- Gaussian Noise Generator, Model 603A, S/N 049-0016, Calibra-
tion Due Date 3/2/78
- 4 MHz Low Pass Filter, LEC Built
- Noise Mixer, LEC Built
- Data Bus Signal Generator (DBSG), LEC Built
- MDM SIO Tester, LEC Built
- Data Bus Couplers (DBC's), Singer S/N 0029 and S/N 0026
- Data Bus Cable, Teledyne Thermatics (twisted shielded pair
with triax connectors)
- Tektronics Type 454 Oscilloscope, S/N B287496, Calibration
Due 5/4/78
- Tektronics C-30A Camera, S/N B021402
- Hewlett-Packard 651A Test Oscillator, S/N 434-00882, Cali-
bration Due 3/2/78
- Hewlett-Packard 3403C True RMS Voltmeter (with Probe Isola-
tion Adapter, P/N 5040-5847)
- Tektronics Type 564 Storage Oscilloscope, S/N 009930, Uncal-
ibrated With Modules:
 - Type 3A74 Four Trace S/N 001728
 - Type 3B3 Time Base S/N 007628
- Tektronics C-12 Camera, S/N 005522
- Simpson Digital Multimeter, Model 460, S/N 17488, Uncali-
brated
- Wavetek Function Generator, Model 103, S/N 266, Calibration
Due 3/2/78

- McIntosh (40 watt) Audio Amplifier, Model MC40, Uncalibrated
- Dummy Loads, LEC Built per ICD for 150 ft of cable
- Laboratory Power Supplies (supply power to Matra SL/BIU test article)

3.3 TEST SOFTWARE

- The software required by the Nova/IOPS will be provided for the Matra SL/BIU level I testing by LEC. See part C of this volume for details on the use of the software in the Nova/IOPS.

4. BASELINE DATA TRANSFER TEST

4.1 TEST DESCRIPTION

The hardware configuration for this test is shown in figure 4-1. This configuration will be used to determine the operational characteristics under normal conditions of data transfer. The cables between MDM B/B and the SL BIU will be initially 5 to 6 ft in length. Once baseline requirements are met, cables are to be extended to 150 ft in length. Tests will also be conducted to determine the interface of adjacent channels (channels in the SIO module not used by the SL/BIU).

4.2 TEST PROCEDURE

This test will be conducted according to the following procedure. The configuration used in this test will be referenced in other tests as the baseline configuration.

4.2.1 The SIO module in the MDM B/B (fig. 4-2) will be prepared in the following manner. (If the SIO module has not been installed in the MDM B/B, see the appendix for installation of input/output (I/O) modules.) The discrete differential drivers for SIO channel 1 will be located on board U18. Three cables, tagged MI, MO, and WD, will be used to connect U18 output to the SL/BIU. One end of each cable will have a 14 pin dual inline package (DIP) module plug; the other, a triax connector.

Connect the module plugs as follows on board U18.

- Message In (MI) - locate first pin at H29
- Message Out (MO) - locate first pin at D29
- Word Discrete (WD) - locate first pin at F29

Board U18 is modified to accept these cables.

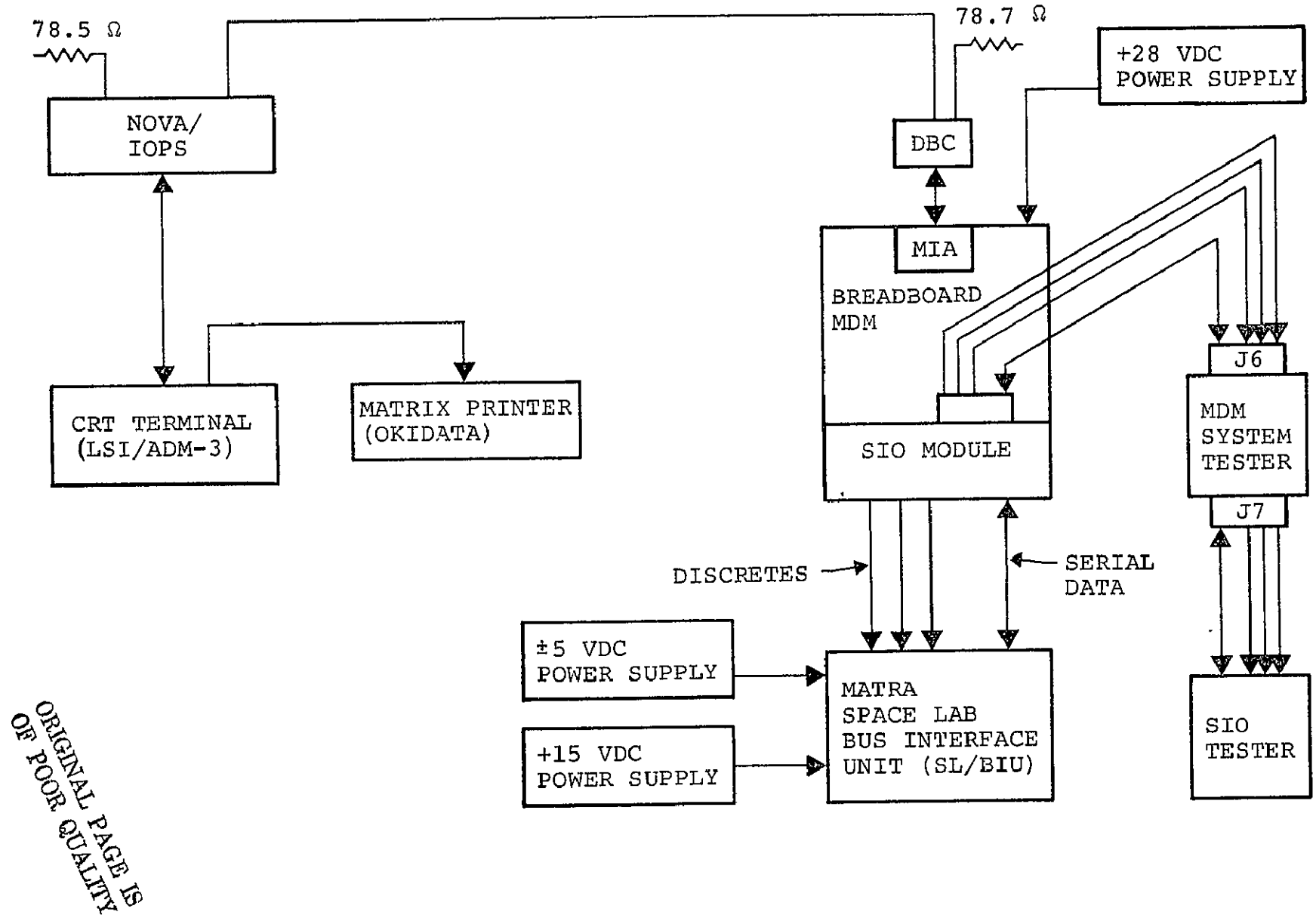

ORIGINAL PAGE IS
OF POOR QUALITY

Figure 4-1.-- MATRA test baseline hardware configuration.

| | | | | | | | | | | | | |
|-----|-----|------|------|------|------|--------|--------------------|--------------------|--------------------|--------------------|------|------|
| U21 | U20 | UX24 | UX23 | UX22 | UX21 | UX20 | U19 | U18 | U17 | U16 | U15 | U14 |
| | H48 | ① | ① | ① | ① | ① ② | CHAN. 0 H51A | CHAN. 1 H51B | CHAN. 2 H51A | CHAN. 3 H51B | A1P1 | A2P1 |
| U1 | U2 | U3 | U4 | U5 | U6 | U7 | U8 | U9 | U10 | U11 | U12 | U13 |
| H90 | H77 | H13 | H76 | H15 | H14 | H79 | ③ H78 | H80 | H53 | H54 | H60 | ④ |

- | | |
|------------------------------------|------------------------------|
| U1 - PARTY LINE RECEIVER | U14 - A2P1 CONNECTOR |
| U2 - SD DE-SKEW | U15 - A1P1 CONNECTOR |
| U3 - BUS RECEIVER | U16 - DISCRETE DRIVER 1 B |
| U4 - SD CONTROL 1 A | U17 - DISCRETE DRIVER 1 A |
| U5 - BUS CONTROL | U18 - DISCRETE DRIVER 1 B |
| U6 - BUS DRIVER 1 | U19 - DISCRETE DRIVER 1 A |
| U7 - SD CONVERTER | UX20- "U18 - CH 1" |
| U8 - SD GENERATOR | UX21- DEBG IF OR DELAY BOARD |
| U9 - SD CLOCK RECEIVER | UX22- NOISE GATE CONT BOARD |
| U10 - SD DECODER 1 A | UX23- SPARE |
| U11 - SD DECODER 2 A | UX24- SPARE |
| U12 - SD-TX-MUX | U20 - POWER SUPPLY MODULE 1 |
| U13 - TRANSFORMERS AND TERMINATORS | U21 - POWER SUPPLY |

NOTES:

- 1 "UX" SLOTS ORIGINALLY SPARE SLOTS IN SIO MODULE.
- 2 U18 MOVED TO UX20 WHEN CHANNEL 1 IS USED BY SL/BIU (CABLING REMAINS INTACT AT SLOT U18).
- 3 U8 HAS ENABLE NRZ CIRCUIT ADDED.
- 4 U13 HAS MODIFIED TERMINATION.

Figure 4-2.- SIO module assembly for MDM B/B.

4.2.2 With the three cables connected to board U18, insert U18 into slot UX20 during SL/BIU testing. On the SIO module backplane, make the following jumper connections:

| <u>Connector-Pin</u> | | <u>Connector-Pin</u> | <u>Signal</u> |
|----------------------|----|----------------------|---------------|
| U18-28 | to | UX20-28 | MIN 1 |
| U18-13 | to | UX20-13 | MOUT 1 |
| U18-14 | to | UX20-14 | WDLN 1 |
| U18-16 | to | UX20-16 | BYPASS |

Relocating board U18 into slot UX20 will disconnect the channel 1 twisted shielded pair (TSP) cabling to the SIO tester without the necessity of extensive wirewrap changes. This allows channel 1 to be reconnected to the SIO tester for check-out by moving board U18 back to slot U18.

4.2.3 The termination of channel 1 serial data cable at the MDM B/B end will initially be left as originally fabricated on board U13 in the SIO module. Later tests will require reconfiguration of this termination. Remove board U13 from the SIO module.

NOTE: This test configuration should have the double-wide eight-resistor module located with the first pin at E5 on board U13 and the two-resistor module located with the first pin at A7 for storage when not being used.

Connect the serial data (SD) cable to board U13 with the first pin at F29. Board U13 is modified to accept this cable.

NOTE: The SIO tester is not connected to the SIO channel 1 serial data driver (U18) on the backplane. If it is necessary to restore channel 1 to the original MDM B/B configuration, make the following jumper connections on the SIO backplane.

| <u>Connector-Pin</u> | | <u>Connector-Pin</u> | <u>Signal</u> |
|----------------------|----|----------------------|---------------|
| U13-15 | to | U15-15 | SD-HI 1 |
| U13-18 | to | U15-18 | SD-LO 1 |

4.2.4 The SIO module tester will be assigned to channel 0. The large selection switch on the rear of the tester should be set to 0 (most counterclockwise position).

4.2.5 The preliminary system functional operation can be verified by using the MBE RAM model for data transfer control. The use of the MBE allows for easier oscilloscope display setup. Signals can be photographed, and signal parameters can be measured for logging prior to running the data transfer error tests with the Nova/IOPS. Remove all the probes during test runs with the Nova/IOPS.

4.2.5.1 The Matra SL/BIU should be electrically verified prior to making any connection to the MDM B/B SIO module. To check the SL/BIU, proceed as follows.

- Setup the ± 5 Vdc and +15 Vdc power supplies and verify the voltage output levels with a digital voltmeter.
- Turn off the direct current (dc) power supplies and connect them to the SL/BIU.
- Turn on the dc power supplies and check the load currents for any abnormal current flow (should never exceed 1 ampere in any case).

4.2.5.2 The SIO module installation and configuration checkout preparation is as follows.

- Connect the four 5 ft TSP cables from the SIO boards UX20 and U13 to the dummy loads shown in figure 4-3.

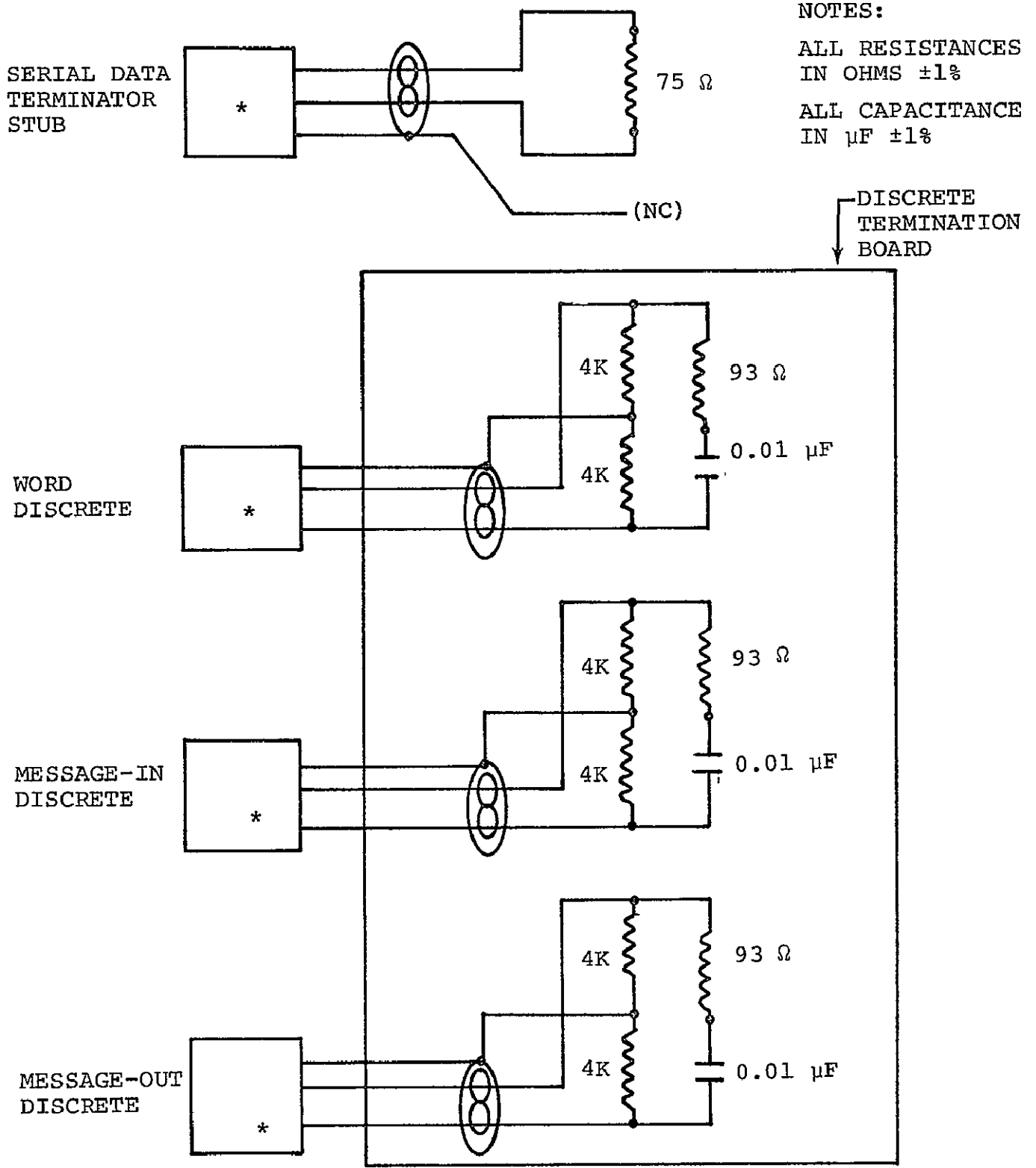

* TRIAX CONNECTOR, PL-76 (4 PLACES)

Figure 4-3.- MDM SIO module dummy loads.

- Connect the MDM B/B data bus to the MBE (RAM model) via DBC's terminated with 78.7 ohm resistors.
- Power up the MDM B/B by switching on the following devices in sequence: the alternating current (ac) line conditioner, the ac power strip inside the MDM B/B rack, and the MDM B/B 28 Vdc power supply.
- Power up the MBE (RAM model) and program the RAM per the example sequence shown in figure 4-4. Start the MBE. The data bus response words from the MDM B/B with the dummy SIO loads will cause the E-bit (bit 23) to be set (turned on) at the MBE front control panel display.

4.2.5.3 Verify and record the signal levels and relative timing parameters at the dummy loads on the four SIO output TSP cables.

4.2.6 Stop the MBE. Disconnect the dummy loads and extend each of the four cables from the SIO module to 150 ft in length. See figure 4-5. Install the dummy loads at the end of the TSP cables. Repeat the same measurements as those taken in paragraph 4.2.5.3 for the 5 ft TSP cable configuration.

4.2.7 Connect the MDM B/B SIO module to the Matra SL/BIU's as follows. To verify the SL/BIU, power down the MDM B/B and the SL/BIU. Stop the MBE transmissions by depressing the RESET button. Disconnect the four dummy loads on the four TSP cables from the SIO module. With four TSP cables, each 5 ft in length, connect the SL/BIU to the four TBD ft long overhead cables using double ended cable coupling connectors. (All four cables must be equal in length, 150 ft each.)

Power up the SL/BIU and check for signals on the SD line. No signals should be seen at this time. The MBE and the MDM B/B must be active to cause proper SD responses.

| R A M A D D R E S S | BIT NUMBER | 1 | 5 | 6 | 10 | 11 | 14 | 15 | 19 | 20 | 24 | |
|--|------------|-------------|---|---|----------------|-------------|----|----|----------------|------------|-------|---|
| | CW FORMAT | MDM ADDRESS | | | MODE | IOM ADDRESS | | | CHANNEL NUMBER | WORD COUNT | | |
| | CDW FORMAT | MDM ADDRESS | | | ← DATA FIELD → | | | | | | 1 0 1 | |
| | RDW FORMAT | MDM ADDRESS | | | ← DATA FIELD → | | | | | | S E V | |
| 0 | CW 1 | 0 | 0 | 0 | 1 | 1 | 0 | 1 | 0 | 0 | 0 | 0 |
| 1 | CDW | 0 | 0 | 0 | 1 | 1 | 0 | 0 | 0 | 1 | 1 | 1 |
| 2 | CW (DUMMY) | 1 | 0 | 0 | 1 | 1 | X | X | X | X | X | X |
| 3 | CW 2 | 0 | 0 | 0 | 1 | 1 | 0 | 1 | 0 | 0 | 1 | 0 |
| * | RDW | 0 | 0 | 0 | 1 | 1 | 0 | 0 | 0 | 1 | 1 | 1 |

*NOT LOADED MANUALLY INTO RAM.
WILL APPEAR IN LED DISPLAY WHEN
RECEIVED FROM MDM.

Figure 4-4.— MBE (RAM model) data pattern for
baseline data transfer test.

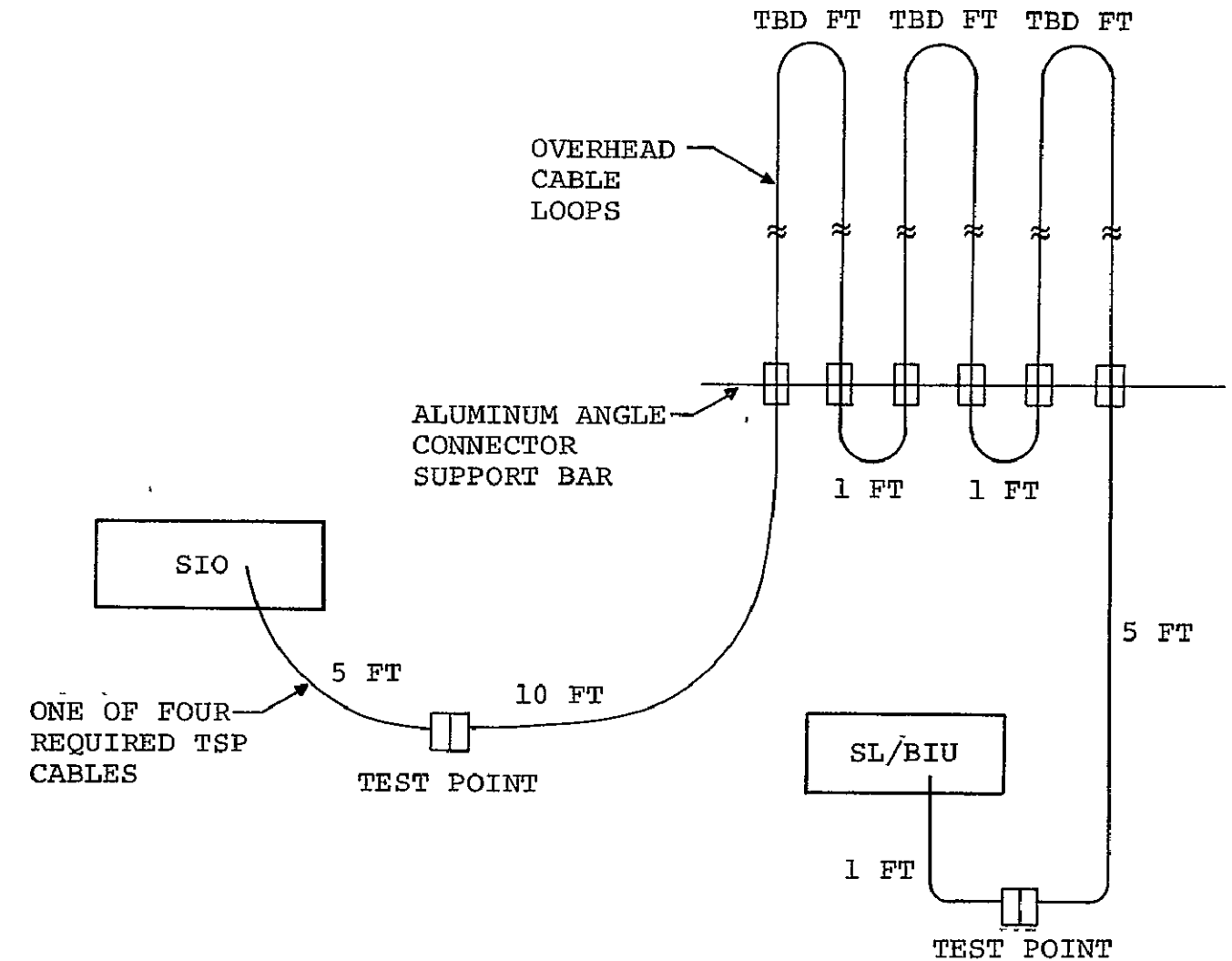

NOTES:

TEST POINTS SHOW WHERE DUMMY LOADS ARE CONNECTED

—□— = CABLE JUNCTIONS

TOTAL LENGTH = TBD FT

Figure 4-5.— Four MDM SIO cables to SL/BIU (SD, WD, MO, and MI).

NOTE: The power off condition of the MDM B/B should not allow any false SD signals to be generated by the SL/BIU transmitter.

Power down the SL/BIU.

4.2.8 Verify the MDM B/B signal parameters as follows.

- Power up the MDM B/B and start the MBE.
- Verify that the signal amplitudes and the polarities are generally proper per ICD requirements for no power on the SL/BIU.
- Power up the SL/BIU.
- Note the serial data transfers between the SIO module and the SL/BIU.
- The MBE control panel response word E-bit (bit 23) indicator should now be off.

4.2.9 Validate the data transfer as follows.

4.2.9.1 With an oscilloscope, verify that the word pattern on the data bus between the MDM B/B and the MBE is the sequence command word - command data word - command word - command word - response data word (CW-CDW-CW-CW-RDW).

4.2.9.2 Compare the RDW data pattern displayed on the MBE to the bit pattern sent in the CDW (bits 6 through 21 in fig. 4-4). The address field and the SEV-bits are dependent upon MDM B/B operation. A failure in the SL/BIU to transmit when commanded by the MDM B/B will cause the E-bit to be set.

4.2.9.3 Verify the data patterns on the SIO/BIU data links at the SL/BIU connections.

4.2.10 Record the signal parameters and photograph the signals. Log all relative information to identify each photograph. Record the following at the ICD interface and at each end of the TSP cables.

- Signal levels [line to line (L-L) on data, L-L and line to ground (L-G) on discretets]
- Signal rise/fall times (L-L all lines)
- Data and discrete signal phasing
- System word error rate (WER) under laboratory ambient conditions
- Ripple and noise on data line
 - a. During the interword gap time
 - b. When transmitting
 - c. When transmitting on adjacent channel (to/from SIO subsystem simulator)
 - d. For first 5 μ s after MDM transmission
- Pulse width jitter (all lines)
- Ripple and noise on discrete lines
- Photograph all four signals on the four trace oscilloscopes
- Photograph serial data signal for CDW, RDW and interword gap between CDW and RDW

4.2.11 Once the baseline test configuration is ready, disconnect the MBE data bus and connect the Nova/IOPS data bus. Run data error checking tests to establish an operational baseline for the overall test configuration.

4.2.12 Run adjacent channel tests by selecting channels 0, 2, and 3 for at least five sets of 32 data word blocks. The SIO module must be switched to the appropriate channel for each

channel test. The channel select switch is on the rear of SIO tester. Power down the SIO tester before changing the channel to avoid logic input transients on the receivers.

Once the channel is selected, power up the SIO tester and start the Nova/IOPS data transfer test.

5. RISE TIME, AMPLITUDE, AND OFFSET VARIATION TEST

5.1 TEST DESCRIPTION

The hardware configuration for this test is shown in figure 5-1. The SIO serial data in the nonreturn to zero (NRZ) form and a synthetically generated ENABLE signal will be taken from the SIO transmitter circuit and fed to an interface board inserted into an unused card slot (UX21) in the SIO module. This board will have buffer drivers for the Data Bus Signal Generator (DBSG) analog board input receivers.

The output of the DBSG will be adjustable with respect to the rise time, amplitude and offset. The DBSG output impedance will "replace" the SIO terminator which is to be removed while the DBSG is being used as the SIO data line driver. The SIO data line will be internally connected to the SIO receiver and will require no changes. The actual SIO driver circuit (SIO module card U12) must be removed to prevent interference. (See fig. 4-2).

The discrettes (message in, message out and word enable) will remain connected as defined in the baseline configuration.

5.2 TEST PROCEDURE

This test will be conducted using the following procedure, assuming the baseline configuration is still intact.

5.2.1 Power down the MDM B/B.

5.2.2 The three discrete cables from the SIO module will remain connected as in the baseline configuration. (See paragraph 4.2.3, board U18, channel 1 relocated in slot UX20).

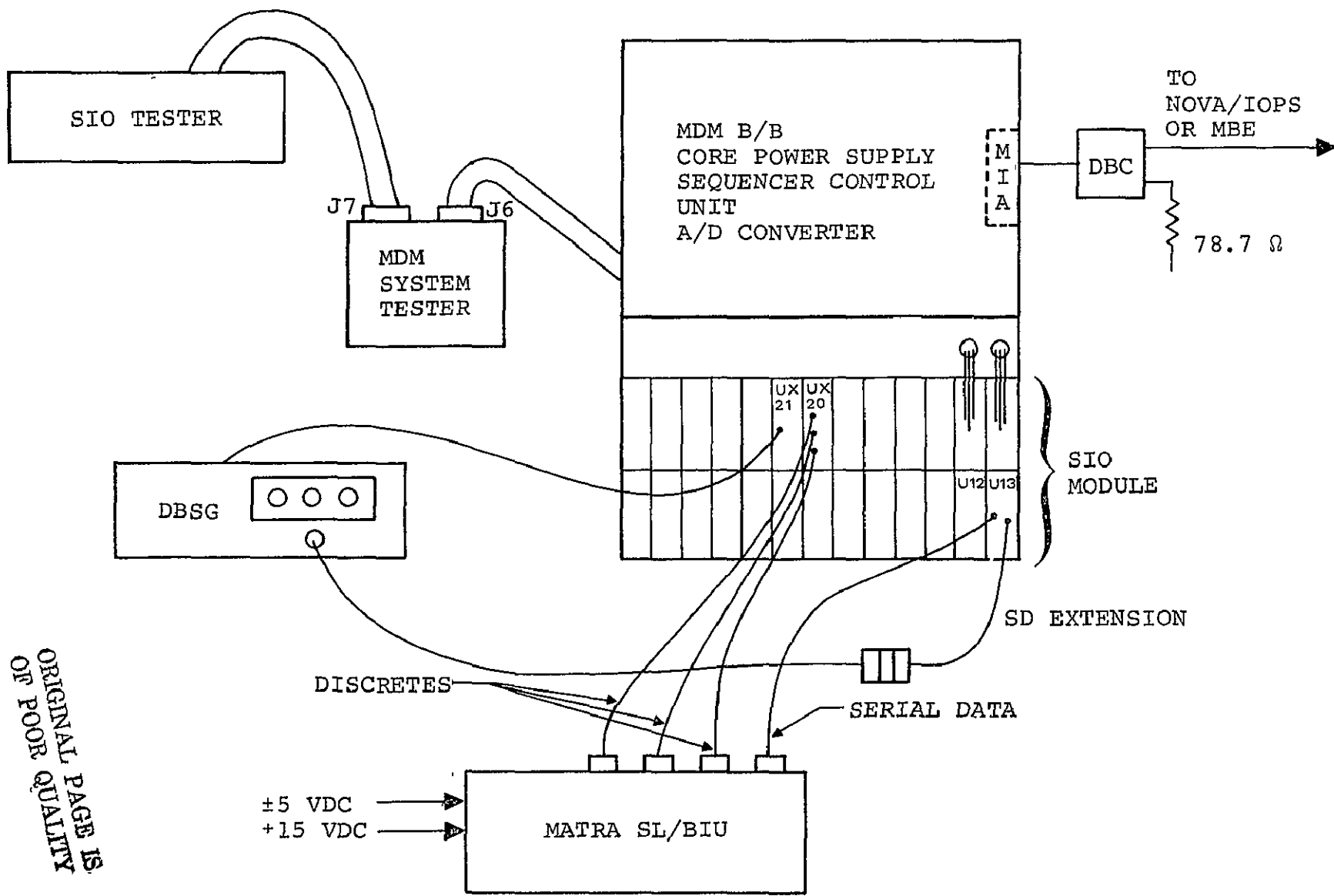

ORIGINAL PAGE IS
OF POOR QUALITY

Figure 5-1.- Rise time, amplitude, and offset variation test configuration.

5.2.3 Attach the DBSG input cable (three twisted pairs) to the DBSG interface card such that the first pin of the 16 pin module plug will be at E28. Insert the interface card into slot UX21. On the backplane of the SIO module remove the U18-13 to UX20-13 and the U18-14 to UX20-14 jumpers. Jumper the following pins:

| <u>Connector-Pin</u> | | <u>Connector-Pin</u> | <u>Signal</u> |
|----------------------|----|----------------------|---------------|
| U8-31 | to | UX21-21 | /NRZP |
| U8-30 | to | UX21-25 | /NRZN |
| U8-50 | to | UX21-47 | /XMT VCC ON |
| U8-60 | to | UX21-29 | ENABLE |
| U18-13* | to | UX21-33 | MOUT-IN |
| U18-14* | to | UX21-41 | WDLN-IN |
| U18-16 | to | UX20-16 | BYPASS |
| U18-28 | to | UX20-28 | MIN |
| UX21-37 | to | UX20-13* | MOUT-OUT |
| UX21-45 | to | UX20-14* | WDLN-OUT |

5.2.4 Remove the terminator from the channel 1 serial data extension cable coming from board U13 in the SIO module. Attach the cable to the DBSG triax output connector.

NOTE: If the extension cable is not attached to SIO board U13, then remove board U13. Move the terminator resistor module (double-wide adaptor assembly with eight resistors) down four wirewrap pins (first pin E5 to E9). Next move the two resistor module up two wirewrap pins (first pin A7 to A5).

This procedure will open the termination for channel 1 and will maintain terminations for channels 0, 2, and 3. Now attach

*Previously directly connected signals will now have hex-inverter delays added in the circuit on UX21.

the termination extension cable to the wirewrap pins for channel 1. To E7 connect the low signal side (blue wire with red stripe); to H7 connect the high signal side (blue wire); and to F7, the shield (remains floating). Replace board U13. Remove board U12 (serial data transmitter, SD-TX-MUX) from the SIO module while DBSG is used as the SD line driver.

5.2.5 Power up the MDM B/B and the DBSG. Adjust the output of the DBSG with the three function variation controls and offset select switch for amplitude, rise time, and positive/negative offset. Observe the SD signal at the SL/BIU input. Use the MBE (RAM model) to set up the output signal parameters prior to running under Nova/IOPS control for software error checking. Vary the amplitude, the rise time, and the offset and note the signal characteristics prior to and after each test run (changes in the signal during the test will invalidate the test results). Remove all the probes when the tests are run with the Nova/IOPS. Record the following at the ICD interface and at each end of the cable.

- Signal levels (L-L on data, L-L and L-G on discrettes)
- Signal rise/fall times (L-L all lines)
- Data and discrete signal phasing
- System WER under laboratory ambient conditions
- Ripple and noise on the data line
 - a. During interword gap time
 - b. When transmitting
 - c. When transmitting on adjacent channel (to/from SIO subsystem simulator)
 - d. For first 5 μ s after MDM transmission
- Pulse width jitter (all lines)
- Ripple and noise on the discrete lines

5.2.6 Noise can be inserted at the SL/BIU to obtain data for various S/N ratios using the adjustment amplitude, rise time, and offset. See the noise test procedure in section 7.

5.2.7 After all tests have been run, power down the MDM B/B and the DBSG. Replace the SIO board U12. Disconnect the DBSG output cable and replace the termination on the serial data cable from board U13. Remove the jumper connections made in paragraph 5.2.3. Reconnect the U18-13 to UX20-13 and the U18-12 to UX20-14 jumpers. Remove all other connections installed during this test setup.

6. VARIATION OF SERIAL DATA AMPLITUDE TEST

6.1 TEST DESCRIPTION

The hardware configuration for this test is shown in figure 6-1. The signal amplitude from the SIO serial data driver will be varied by adjusting an external dc power supply in the range of 0.0 Vdc to +6.3 Vdc. No baseline configuration changes other than disconnecting the internal +6.3 Vdc line on the SIO backplane and replacing it with an external dc voltage source will be required.

This test may be used in conjunction with the noise injection test at the SL/BIU serial data input. This will permit variable S/N ratios to be obtained at the serial data input of the SL/BIU with the MDM B/B serial data driver still in the circuit.

6.2 TEST PROCEDURE

This test will be conducted according to the following procedure, assuming that the baseline configuration is still intact.

6.2.1 Power down the MDM B/B.

6.2.2 On the SIO module backplane, remove the jumper wire from connector-pin U12-40 to U14-36. This will open the +6.3 Vdc line to the serial data transmitter board U12.

6.2.3 Connect an external dc power supply (power off and output voltage level control knobs set to 0.0 Vdc) to the SIO backplane pins U12-40 (+6.3 Vdc input) and U12-02 (SIO ground). Use the special cable with the power decoupling capacitors across the leads. Allow the dc voltage source return line to float (do not connect the case ground).

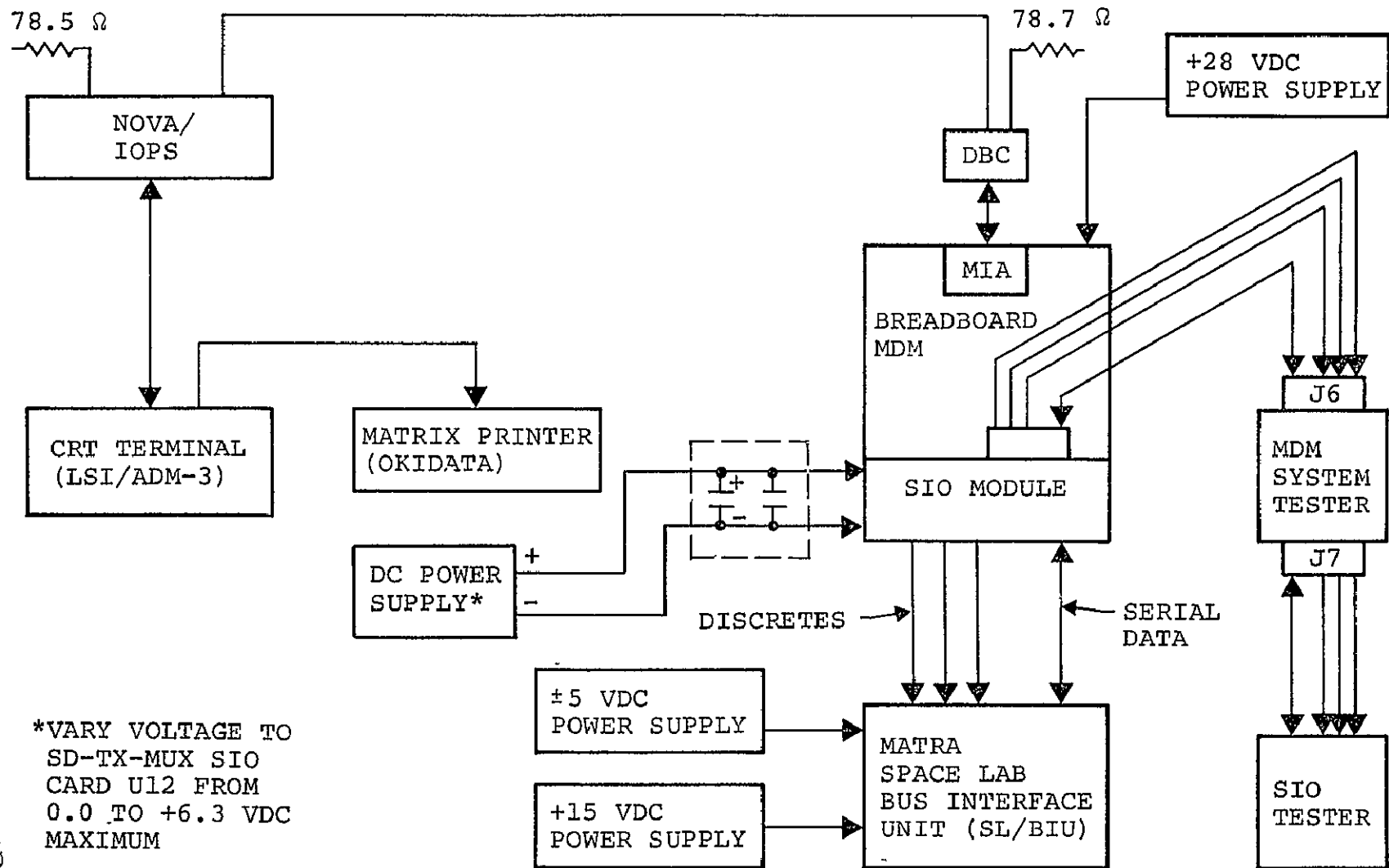

ORIGINAL PAGE IS
OF POOR QUALITY

Figure 6-1.— Variation of serial data amplitude test configuration.

6.2.4 Adjust the external dc power supply voltage level to +6.3 Vdc. Run a data transfer test to reverify the baseline. Run the data transfer tests again decrementing the voltage level by 0.5 Vdc starting at +6.0 Vdc until the errors occur. Once errors occur, take photographs and note the parameters of the serial data signal at the MDM B/B and SL/BIU input-output connections. Decrement in steps of 0.2 Vdc until the WER is greater than 1×10^{-5} .

6.2.5 After this test is complete, disconnect the external power supply and restore the jumper that was removed in step 6.2.2

7. NOISE TEST

7.1 TEST DESCRIPTION

The hardware configuration for this test is shown in figure 7-1. A differential noise source will be used in a three part test to inject noise onto the differential discrete lines at the SL/BIU inputs, the differential serial data lines at the SL/BIU inputs, and the differential serial data lines at the MDM B/B inputs.

The noise generator output will pass through a 4 MHz low pass filter and then drive a differential buffer circuit. The noise will be gated by logic signals generated within the SIO. When noise is applied to SL/BIU inputs, it will be gated by the message out and word enable internal discrete logic signals. A buffer logic board will be inserted into an unused card slot within the SIO module. When noise is applied at the MDM B/B serial data input, it will be gated by the message in and word enable discrete logic.

The signal and noise mixer is an analog device that has the capability of adding two signals algebraically. The input and output impedances will be matched to the data bus cable so that the signals are not distorted. Variable mixer gain for the signal will allow for the adjustment of desired S/N ratios.

7.2 TEST PROCEDURE

This test will be conducted using the following procedure, assuming the baseline configuration is still intact.

7.2.1 Power down the MDM B/B. It is advisable to power up the noise generator, noise filter, and noise mixer 1 hour prior to use to stabilize the electronics. Power down the noise mixer prior to connecting the cables.

7-2

ORIGINAL PAGE IS
OF POOR QUALITY

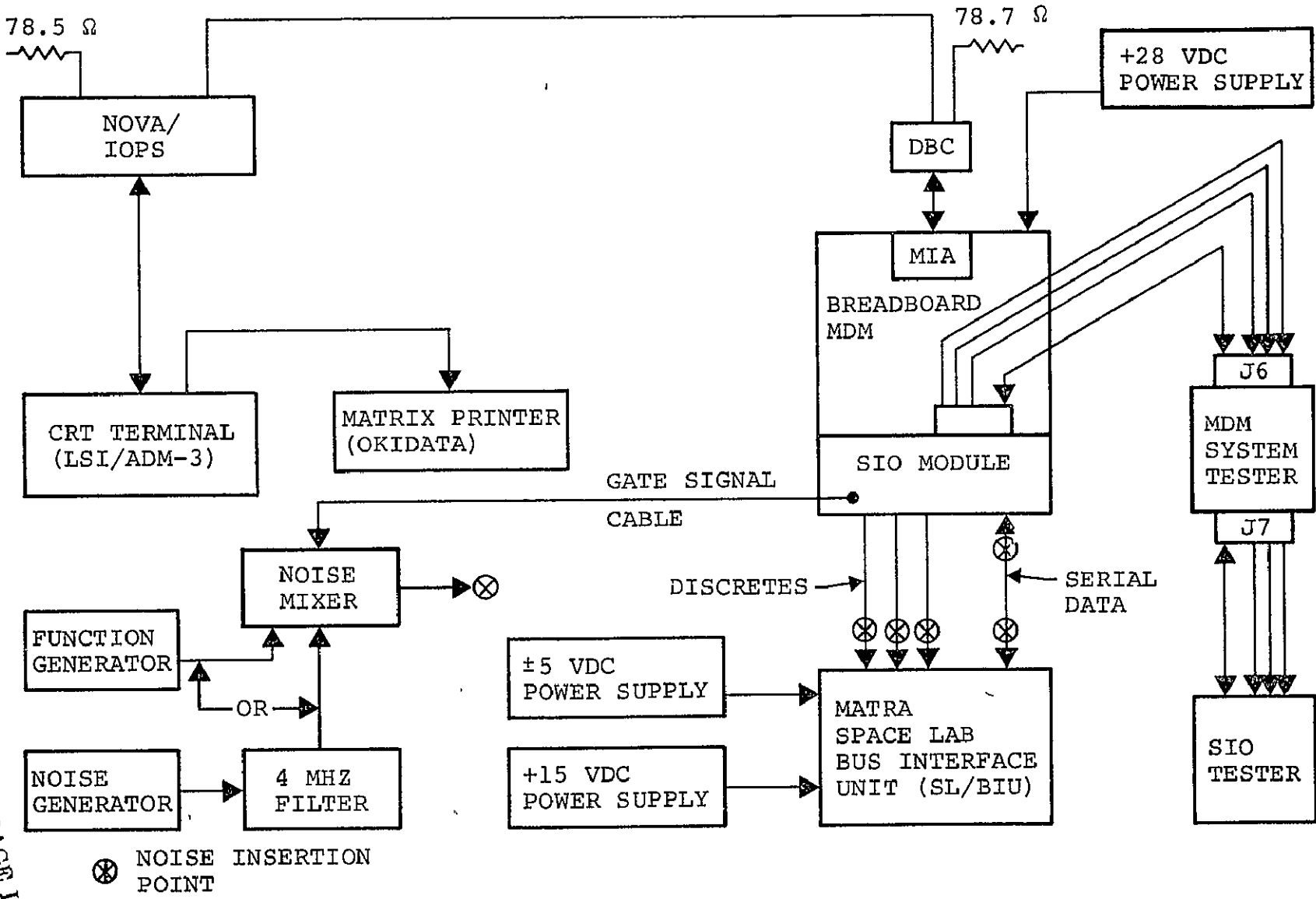

Figure 7-1.- Matra noise test configuration.

7.2.2 The cables to the SL/BIU will remain connected as defined in the baseline configuration.

7.2.3 Noise will always be injected across active differential lines. Terminations will remain intact unless otherwise noted. Select one of the following three noise injection points and continue to paragraph 7.2.4.

7.2.3.1 To inject noise at the MDM B/B SIO serial data receiver, use the signal and noise mixer as shown in figure 7-2. Remove the 75 ohm termination stub from the board U13 extension of the serial data line. (See paragraph 5.2.4 if stub and extension have not been installed.) Connect the extension cable from board U13 to the mixer output. The output impedance of the noise mixer will effectively replace the 75 ohm terminator of the serial data cable at the SIO module. Continue with the procedure in paragraph 7.2.4.

7.2.3.2 To inject noise at the SL/BIU serial data receiver, use the signal and noise mixer as shown in figure 7-3. Remove the 75 ohm terminator resistor from the SL/BIU input/output circuit. Disconnect the SD cable from the SL/BIU and insert a T-connector in the place of the inline cable to cable adapter. Connect a short piece of data bus cable between the T- and the noise mixer output. Continue with the procedure in paragraph 7.2.4..

7.2.3.3 To inject noise at the SL/BIU discrete inputs use the signal and noise mixer as shown in figure 7-4. Disconnect the desired line and remove the cable inline adapter. Connect the discrete line from the SIO module to the signal input connector of the mixer. Terminate the mixer input to maintain signal characteristics. Connect the input TSP line of the SL/BIU to the mixer output connector.

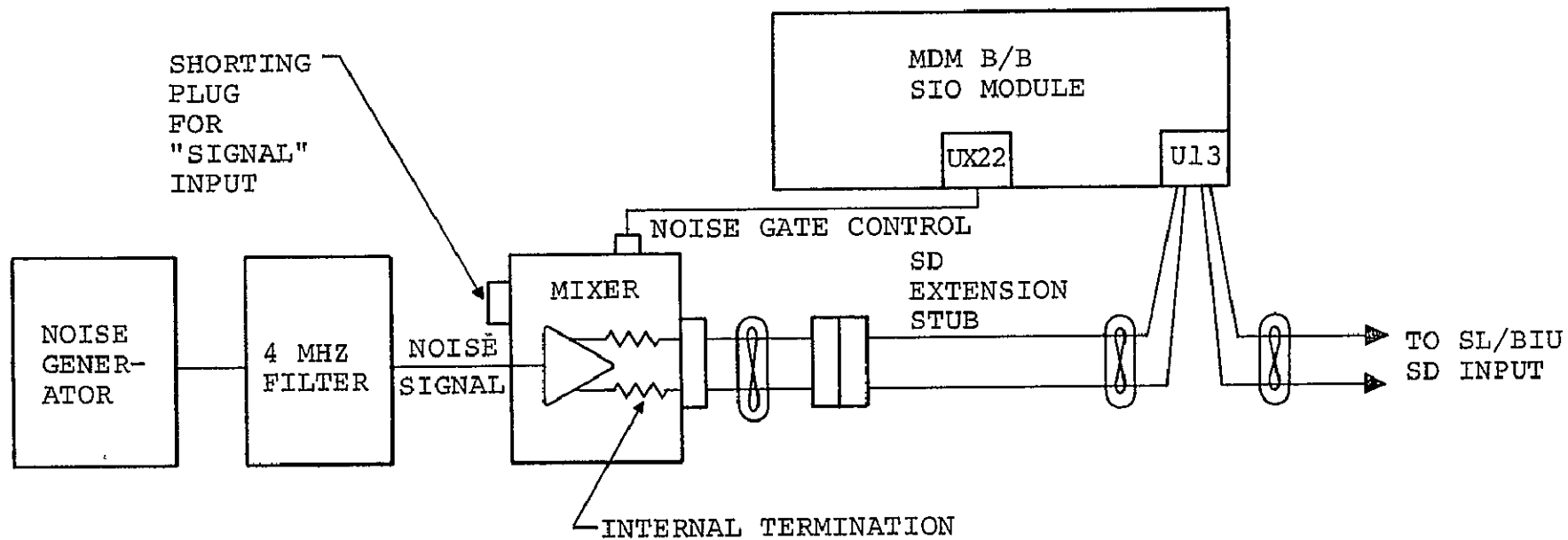

Reference paragraph 7.2.3.1

Figure 7-2.- Noise injection at MDM B/B SD receiver.

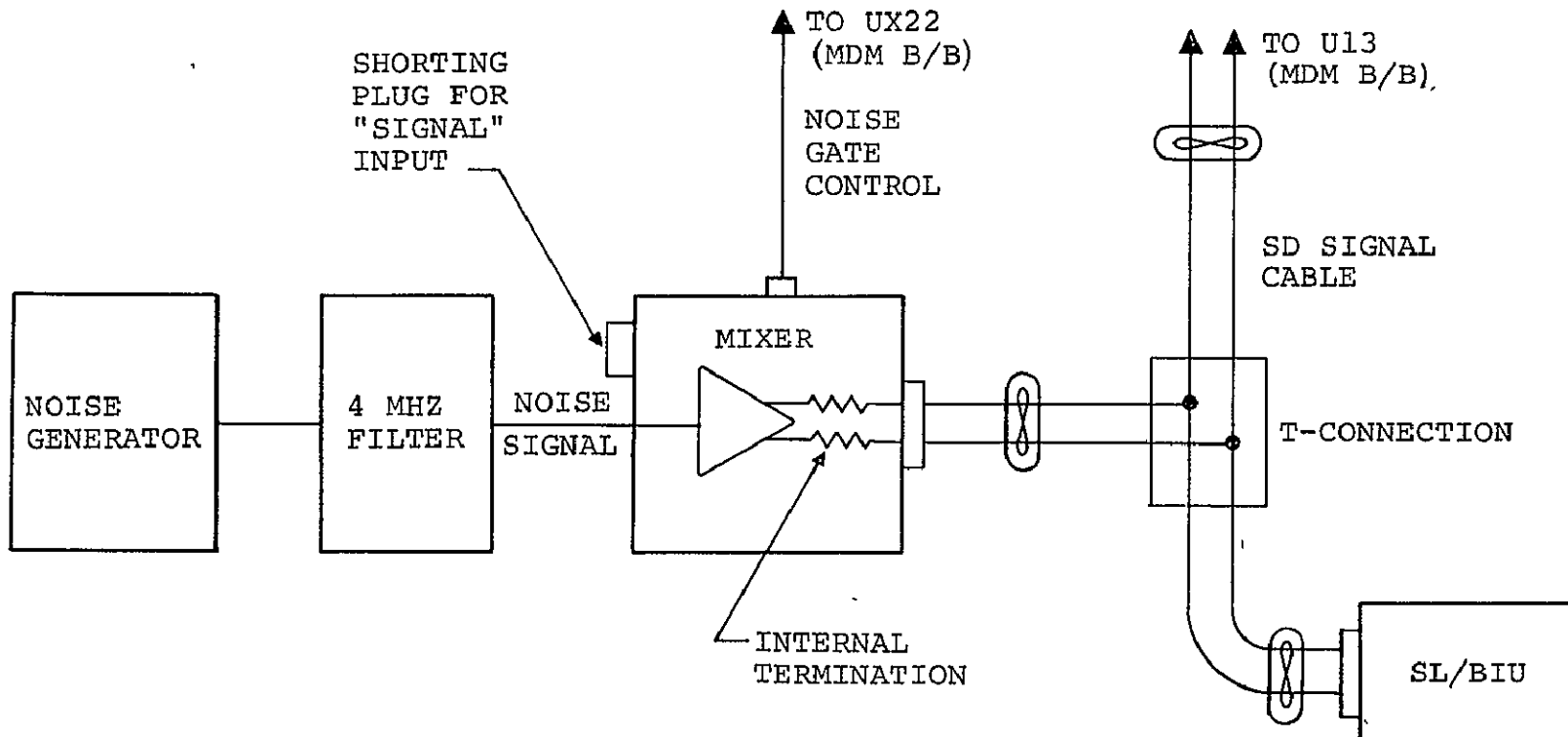

Reference paragraph 7.2.3.2.

Figure 7-3.- Noise injection at SL/BIU SD receiver.

ORIGINAL PAGE IS
OF POOR QUALITY

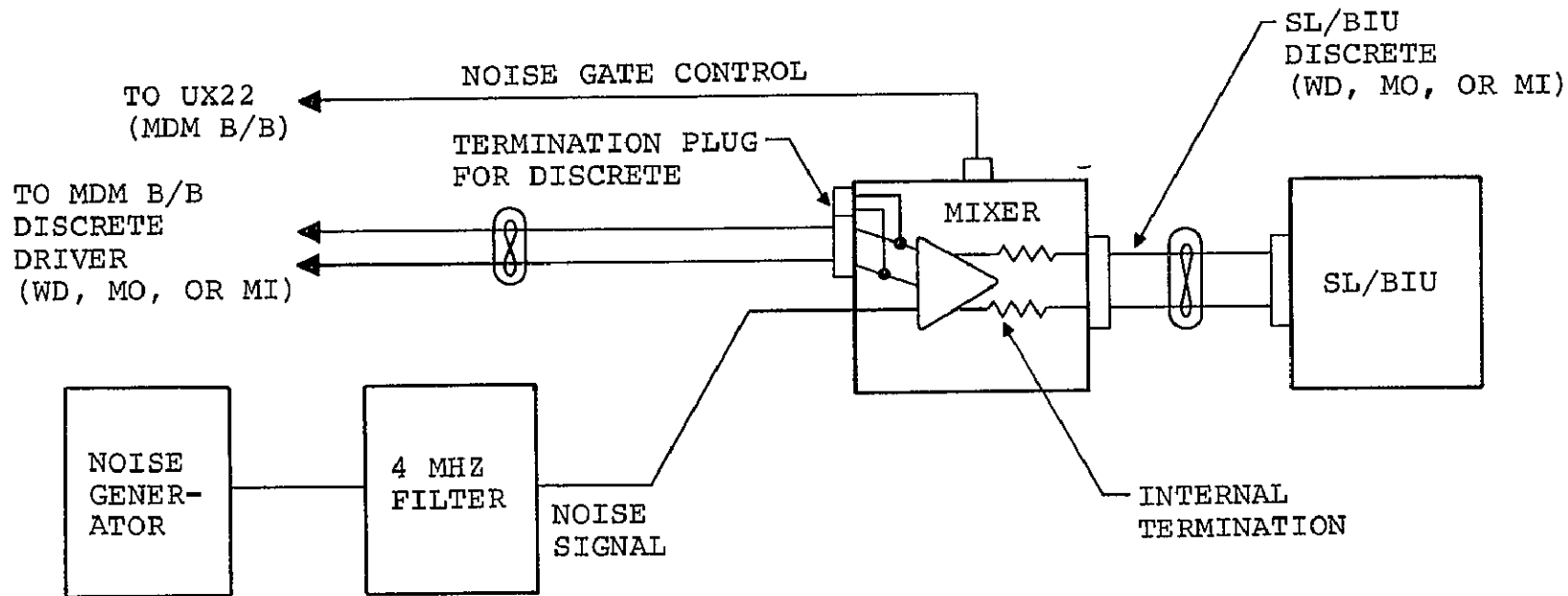

Reference paragraph 7.2.3.3.

ORIGINAL PAGE IS
OF POOR QUALITY

Figure 7-4.— Noise injection at SL/BIU discrete receiver.

7.2.4 Power down the noise mixer. Insert the noise gate control card into slot UX22 of the SIO module. The cable connection on the board will have the first pin located at E29. This cable will be connected to the noise mixer pattern control connector (next to the BNC type noise input connector on the noise mixer unit).

7.2.5 Connect the noise generator output to the noise filter input using coaxial cable. Also connect the noise filter output to the noise input connector next to the gate control connector using coaxial cable. If a function generator is to be used, connect the output of the function generator to the noise input connector next to the gate control connector.

7.2.6 Power up the MDM B/B and the noise mixer. With no line signal present, adjust the noise level at the SIO or SL/BIU connection using the True RMS voltmeter to monitor the noise level. On the backplane of the SIO, check that the control pins on connector UX22 (pins 31 and 41) are not patched to any other pin.

NOTE: The True RMS voltmeter must be used with the probe isolation adapter (Hewlett-Packard part no. 5040-5847) installed to float the probe shield from the case ground during noise level measurements.

7.2.7 Noise gating can be controlled by the discrete logic within the MDM B/B SIO module.

7.2.7.1 If the noise is applied to the serial data line at the MDM B/B, the control signals will be the message in (MIN 1) and word discrete (WDLN 1) lines for channel 1. For this case, patch on the SIO backplane the following.

| <u>Connector-Pin</u> | | <u>Connector-Pin</u> | <u>Signal</u> |
|----------------------|----|----------------------|---------------|
| U18-28 | to | UX22-31 | MIN 1 |
| U18-14 | to | UX22-41 | WDLN 1 |

7.2.7.2 If the noise is applied to any of the SL/BIU inputs, the control signals will be the message out (MOUT 1) and word discrete (WDLN 1) lines for channel 1. For this case, patch on the SIO backplane the following.

| <u>Connector-Pin</u> | | <u>Connector-Pin</u> | <u>Signal</u> |
|----------------------|----|----------------------|---------------|
| U18-13 | to | UX22-31 | MOUT 1 |
| U18-14 | to | UX22-41 | WDLN 1 |

7.2.7.3 If continuous noise is desired during the complete message, remove WDLN (U18-14 to UX22-41) from the preceding cases in paragraphs 7.2.7.1 and 7.2.7.2.

7.2.7.4 If the continuous noise is desired during the test in both directions of data transfers, do not patch any of the three signals (MIN, MOUT, or WDLN) to UX22.

7.2.8 Noise can be added to reduced serial data signal amplitudes to obtain various S/N ratios (see sections 5 and 6.) Also, it is possible to adjust the internal mixer signal gain to lower the signal amplitude mixed with the noise. Make preliminary test runs with no noise present to validate the hardware configuration. Remove all the probes when tests are run with the Nova/IOPS.

7.2.8.1 For serial data line S/N performance

- Gate 300 mV root mean square (RMS) noise (1 kHz to 4 MHz) onto the data line when the SL/BIU is receiving. Determine the WER. If the WER is greater than 2×10^{-6} , decrease the noise level in 50 mV increments until the WER is less than 2×10^{-6} .

- Increase the noise level in 50 mV increments until the WER is greater than 1×10^5 .
- Gate 300 mV RMS noise onto the data line when the MDM B/B SIO is receiving. Determine the WER. (The SL/BIU serial data signal amplitude can be varied.) Vary the noise levels by 50 mV increments to find the data transfer WER at 2×10^{-6} for the SIO.

7.2.8.2 For discrete line S/N performance

- Place TBD mV pk-pk L-L of TBD frequency sine wave on each pair of discrete lines (one at a time) at the SL/BIU inputs and determine the WER for both the MDM transmitting and receiving cases.
- If the WER is greater than 2×10^{-6} , decrease the noise level in 50 mV increments until the WER is less than 2×10^{-6} .
- Increase the noise level in 50 mV increments until the WER is greater than 1×10^{-5} .

8. SKEW VARIATION OF SERIAL DATA OUTPUT, DATA WORD DISCRETE, AND MESSAGE SIGNALS

8.1 TEST DESCRIPTION

The hardware configuration for this test is shown in figure 5-1. The skew of the signals will be a variation of the Rise Time, Amplitude, and Offset Variation Test. The board used to interface the DBSG will be replaced by a delay board which has DIP switches to select delays desired between MO, MI, WD, and SD. No other circuit changes from the baseline will be required except adding some jumper connections to the delay board in slot UX21.

8.2 TEST PROCEDURE

This test will be conducted using the following procedure, assuming the baseline configuration is still intact.

8.2.1 Power down the MDM B/B.

8.2.2 The three discrete cables from the SIO module will remain connected as in the baseline configuration at board U18 (channel 1) relocated in board slot UX20. Remove the terminator from the channel 1 SD extension cable coming from board U13 in the SIO module. Attach the extension cable to the DBSG triax output connector. Remove board U12 (SD transmitter, SD-TX-MUX) from the SIO module. (See the note in paragraph 5.2.4 if the extension cable is not attached to the SIO board U13.) Connect the DIP plug on the end of the DBSG input cable to the delay board (first pin location at E28).

8.2.3 On the SIO module backplane, connect the following (if not already connected) for the DBSG delay board.

| <u>Connector-Pin</u> | | <u>Connector-Pin</u> | <u>Signal</u> |
|----------------------|----|----------------------|-----------------|
| U18-14 | to | UX21-41 | WDLN 1 |
| U18-16 | to | UX20-16 | BYPASS |
| UX20-14 | to | UX21-45 | WDLN 1D |
| U8-60 | to | UX21-29 | ENABLE |
| U8-31 | to | UX21-21 | /NRZP |
| U8-30 | to | UX21-25 | /NRZN |
| U8-50 | to | UX21-47 | /XMTR VCC-ON |
| EXTERNAL +5 Vdc | to | UX21-60 | BOARD VCC PLANE |
| DC RTN (FLOAT) | to | UX21-02 | BOARD GND PLANE |

NOTE: The BOARD VCC PLANE is isolated from the Vcc backplane of the SIO module by cutting the Vcc printed circuit on the delay board itself.

Keep the dc return line floating; i.e., isolate from the dc power supply case ground. Also use the special cable that has power decoupling capacitors across the leads. Prior to connecting the leads at the external dc power supply, adjust to +5 Vdc and power down.

Connect the multiplexer interface adaptor (MIA) module backplane pins to the SIO module as follows using a twisted pair of wires.

| <u>Connector-Pin</u> | | <u>Connector-Pin</u> | <u>Signal</u> |
|----------------------|----|----------------------|---------------|
| MIA U2-07 | to | SIO UX21-24 | 16 MHz CLK |
| MIA U2-02 | to | SIO UX21-02 | CLK RTN |

8.2.3.1 To delay the MOUT and WDLN discrete signals during message transfers to the SL/BIU with respect to the SD word signal, jumper the following connector-pins on the SIO backplane (if not already connected).

| <u>Connector-Pin</u> | | <u>Connector-Pin</u> | <u>Signal</u> |
|----------------------|----|----------------------|---------------|
| U18-28 | to | UX20-28 | MIN 1 |
| U18-13 | to | UX21-33 | MOUT 1 |
| UX20-28 | to | UX21-32 | MIN 1 |
| UX20-13 | to | UX21-37 | MOUT 1D |

Proceed to paragraph 8.2.4.

8.2.3.2 To delay MIN and WDLN discrete signals during message transfers from the SL/BIU with respect to the SD word signal, remove the wires listed in paragraph 8.2.3.1 and add the following jumpers to the SIO backplane.

| <u>Connector-Pin</u> | | <u>Connector-Pin</u> | <u>Signal</u> |
|----------------------|----|----------------------|---------------|
| U18-28 | to | UX21-33 | MIN 1 |
| U18-13 | to | UX20-13 | MOUT 1 |
| UX20-28 | to | UX21-37 | MIN 1D |
| UX20-13 | to | UX21-32 | MOUT 1 |

8.2.4 Vary the signal skew by changing the eight position DIP switch settings on the DBSG delay interface board. Do not close two switches simultaneously for the same signal (same board column). Open all the switches prior to making a new selection.

Set the delay select switches according to table 8.1. Select the delay increment by choosing GH20 or GH21. Select the number of delay increments by choosing one switch designation under each of the columns labeled MESSAGE (MOUT or MIN, depends on the selection of jumpers in paragraphs 8.2.3.1 and 8.2.3.2), WDLN, NRZ and ENA. (Note that the delay increments for NRZ and ENA must be identical). Once the switches are set, insert the DBSG delay interface board into the SIO card slot UX21.

TABLE 8-1.— DELAY SELECT SWITCH CHART FOR DBSG
 DELAY INTERFACE BOARD

| | |
|-------------------|---------------|
| Delay increment | Close switch* |
| 125.0 nanoseconds | GH20 |
| 250.0 nanoseconds | GH21 |

| No. of delay increments | Message | WDLN | NRZ ^t | ENA ^t |
|-------------------------|---------|------|------------------|------------------|
| 1 | AB19 | CD19 | JK19 | LM19 |
| 2 | AB20 | CD20 | JK20 | LM20 |
| 3 | AB21 | CD21 | JK21 | LM21 |
| 4 | AB22 | CD22 | JK22 | LM22 |
| 5 | AB23 | CD23 | JK23 | LM23 |
| 6 | AB24 | CD24 | JK24 | LM24 |
| 7 | AB25 | CD25 | JK25 | LM25 |
| 8 | AB26 | CD26 | JK26 | LM26 |
| 9 | AB28 | CD28 | JK28 | LM28 |
| 10 | AB29 | CD29 | JK29 | LM29 |
| 11 | AB30 | CD30 | JK30 | LM30 |
| 12 | AB31 | CD31 | JK31 | LM31 |
| 13 | AB32 | CD32 | JK32 | LM32 |
| 14 | AB33 | CD33 | JK33 | LM33 |
| 15 | AB34 | CD34 | JK34 | LM34 |
| 16 | AB35 | CD35 | JK35 | LM35 |

*DO NOT close more than one switch per column pair (each column in table represents a board column pair). Switches connect A-B, C-D, G-H, J-K, and L-M column pairs.

^tNRZ and ENA delays must be identical. These two control the serial data word from the DBSG.

8.2.5 Power up the MDM B/B, the external +5 Vdc power supply, and the DBSG.

8.2.5.1 For the initial setup, connect the MBE (RAM model) data bus MDM B/B. Program and start the MBE. Adjust the DBSG output for the desired signal characteristics at the SL/BIU serial data input. Note the signal characteristics and timing delays between the discrete and serial data signal.

8.2.5.2 Disconnect the MBE data bus at the MDM B/B after the setup is complete. Connect the Nova/IOPS data bus and run a WER test. Remove the test probes when running the WER tests. Reverify the signal timing with the MBE after each WER test run prior to changing the delays for the next test.

8.2.5.3 If the next test continues with the varying of the skew of the same three signals, power down the DBSG first. Then proceed to change the delay switches per table 8-1 and paragraph 8.2.4. It is not necessary to power down the MDM B/B and the dc power supply. If the next test is to vary the skew of a different message discrete pair, then proceed to paragraph 8.2.3.1 or 8.2.3.2 after powering down the MDM B/B, the +5 Vdc power supply, and the DBSG.

8.2.6 Once the desired tests have been run, power down the MDM B/B, the external +5 Vdc power supply, and the DBSG. Replace the SIO board U12. Disconnect the DBSG output cable and restore the terminator to the serial data extension cable from board U13. Remove the DBSG delay board. Remove all the jumpers added to the SIO backplane as given in paragraph 8.2.3. Restore those as listed in paragraph 4.2.2 for the baseline configuration.

9. CABLE LENGTH TEST

9.1 TEST DESCRIPTION

The hardware configuration for this test is shown in figure 9-1. The variation of the length of cables between the SIO and the SL/BIU will be in increments of 10 ft. All four cables will be incremented simultaneously. The cable lengths used on the Shuttle will be duplicated and exceeded in the laboratory tests to provide data on the limitations of the Orbiter-SL/BIU interface based on error rates.

9.2 TEST PROCEDURE

This test will be conducted according to the following procedure, assuming the baseline configuration is still intact.

9.2.1 Stop all data transfers and power down the MDM B/B and the SL/BIU.

9.2.2 Remove the cable inline adapters (bulkhead, jack-to-jack) at the point where the 5 ft cables from the MDM B/B join the short adapter cable to the SL/BIU. With the inline adapters couple 15 ft of data bus into each of the four cables (5 ft + 10 ft sections). This will start the test with 20 ft of cable between the MDM B/B and the SL/BIU.

9.2.3 Run the tests as in the baseline to determine failures. If no failures are found increment the four cables by increments of 20 ft until a failure occurs. Remove all probes when the tests are run with the Nova/IOPS.

9.2.4 When the increase in cable length begins to generate errors, decrement the four cable lengths by 20 ft and run the test again. At this point if errors do not occur as previous

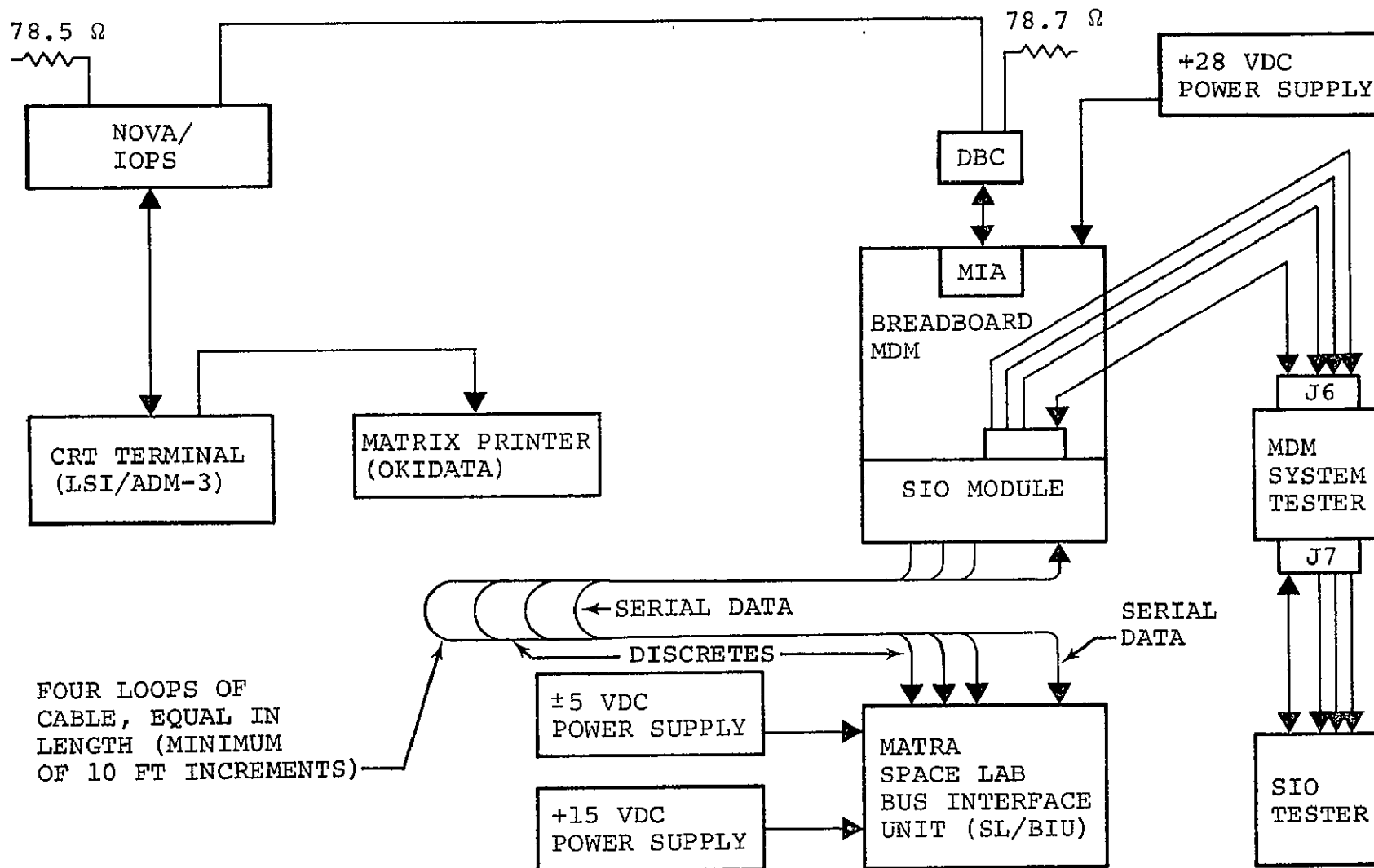

9-2

ORIGINAL PAGE IS
OF POOR QUALITY

Figure 9-1.- MATRA cable length test configuration.

test indicated for this length (n-multiples of 20 ft) take photographs of the serial data and discrete signals. Note the signal parameter values at the MDM B/B SIO and the SL/BIU.

9.2.5 Now increment the four cables by 10 ft increments and again note the parameters. Continue to increment until all of the cable lengths available overhead in the laboratory are used (four sets of 310 ft) or until the WER is greater than 1×10^{-5} . Record the signal parameters and take photographs as necessary to illustrate the signal characteristics.

10. COMMON MODE NOISE TEST

10.1 TEST DESCRIPTION

The hardware configuration for this test is shown in figure 10-1. Low output impedance common mode noise sources will be used to inject noise into the TSP return lines (shields) of the three discrete control lines connecting the MDM B/B SIO module to the SL/BIU. For this test, the shields of the three discrettes will be disconnected from the SIO module ground and will be reconnected together at one common point. This common shield tie point will be connected to one of the common mode noise source output terminals. The remaining common mode noise source output terminal will be connected to the SIO module ground to which the TSP discrete shields are previously connected. See figure 10-1.

10.2 TEST PROCEDURE

This test will be conducted according to the following procedure, assuming the baseline configuration is still intact.

10.2.1 The signal generator and power amplifier should be powered up at least one half an hour prior to use to allow the electronics to stabilize. Power down as necessary when connecting the common mode source into the discrete lines.

10.2.2 Power down the MDM B/B and SL/BIU. Remove the discrete driver board from location UX20 in the SIO module. Disconnect the three discrete TSP cable shields (D30, F30, H30) from the SIO digital ground (D-GND) plane by removing the jumper wires on the wirewrap side of the board. Connect the three shields together. Connect a TBD length of wire to this common shield connection. Connect a similar length of wire to the ground plane of the board. Insert the board into slot UX20 of the SIO module.

ORIGINAL PAGE IS
OF POOR QUALITY

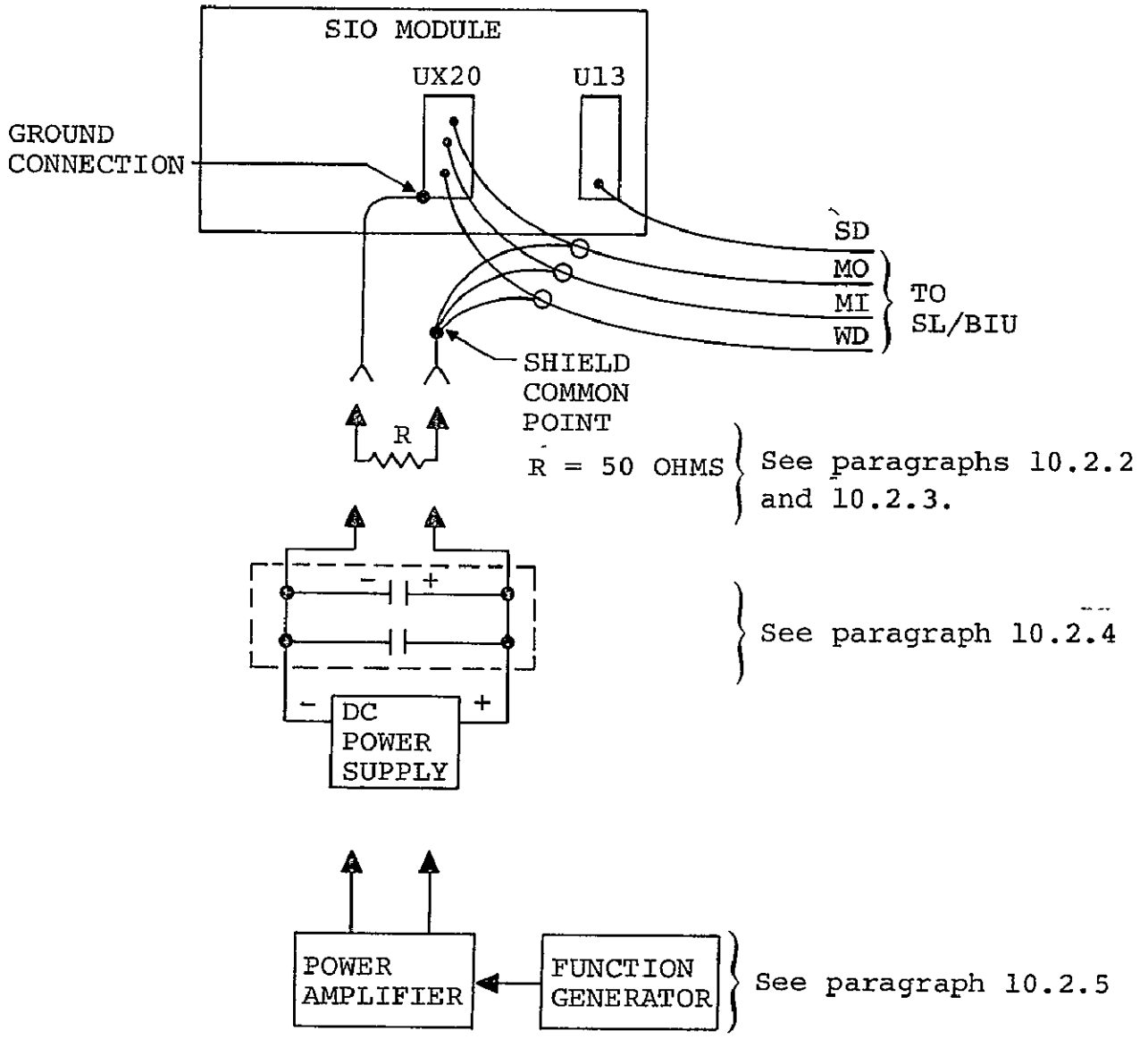

Figure 10-1.- Common mode noise injection circuit.

NOTE: The SD cable shield is left open at the SIO module end. (It is electrically connected to the others at the TSP bulkhead connector support bar on the laboratory workbench).

10.2.3 Connect a 50 ohm resistor in series with the shields and the ground on board UX20 using the two lengths of wire attached in step 10.2.2. Power up the MDM B/B and the SL/BIU. Run a baseline WER test with the Nova/IOPS to determine if the 50 ohm resistor will introduce errors in the data transfer.

10.2.4 Remove the 50 ohm resistor. Connect a dc power supply (with power turned off and output level control adjusted to 0.0 Vdc) in series with the shields and ground plane on board UX20. Connect the dc power supply using the prefabricated wires with the dc decoupling capacitor and the radio frequency bypass capacitor across the two power leads having "quick disconnect" terminals at the load end. Connect them so that the negative dc terminal is on the ground plane of board UX20 and the positive terminal is on the discrete shields. Keep the power supply case ground floating with reference to the dc voltage output. Power up the power supply. Run a minimal WER test to verify this circuit change will not cause an error in data transfers. When the WER test has been completed, adjust the dc power supply output level to +10 Vdc (referenced to the ground plane of board UX20). Rerun the WER test.

Switch off the dc power supply and reverse the power leads at the UX20 board. Turn on the dc power supply and adjust to +10 Vdc level. This puts -10 Vdc common mode voltage on the shields referenced to the board UX20 ground. Repeat the WER test. This completes the dc common mode signal test.

10.2.5 Power down the dc power supply, the MDM B/B, and the SL/BIU. Disconnect the dc power source and replace with the 40 watt audio power amplifier. Use the 16 ohm output terminals and leave the low output terminal floating with respect to the case ground. Connect the function generator output to the input of the audioamplifier. Power up the MDM B/B and the SL/BIU. Power up the audioamplifier with the gain turned down to the lowest level. Power up the function generator, select the sine wave frequency desired, and set the output to about one-third of the maximum output level. Adjust the audioamplifier output to the desired level. Use an oscilloscope to check for any signal distortion whenever signal amplitude is varied. Run a WER test with the Nova/IOPS. If errors occur, adjust the level of the audioamplifier output to the zero level and repeat the WER test. If no errors occur, change the frequency and repeat the WER test with the signal level set to the desired level of the common mode signal. Repeat as necessary using different frequency settings in the desired range or to the range limits of the audioamplifier.

NOTE: For frequencies higher than 150 kHz, the 10 Vp common mode signal amplitude level is not available from the audiorange power amplifier.

APPENDIX

PROCEDURE FOR SWAPPING I/O MODULES IN THE MDM B/B

- A.1 Turn off the 28 Vdc power supply for the MDM B/B.
- A.2 Remove the two cable connector boards (A1P1 and A2P1) from the I/O module (IOM) in the MDM B/B. (IOM may be a single or double card cage).
- A.3 Life out the IOM and replace it with the desired IOM.
- A.4 Reconnect the two cable connector boards (A1P1 and A2P1) into the same respective locations as used with the previous IOM.
- Two slots on the double IOM - upper right corner
 - Two slots on the single IOM - right hand end.
- A.5 Connect the MDM system tester input cable from A1P1 and A2P1 (backplane side) to the appropriate input listed below.
- | | |
|--|-----------------|
| J1 - AID/SE | J4 - D05 (DOL) |
| J2 - AØD | J5 - D028 (DOH) |
| J3 - DI5/28 (DIL/DIH) | J6 - SIO |
| J7 - Output to SIO tester (can remain connected even if not used). | |
- A.6 To reconfigure the MDM B/B for a new IOM, remove the existing pair of select code line jumpers on the backplane and replace with the pair of IOM select code lines required for the new IOM as follows in (a) and (b).
- (a) On the analog to digital (A/D) converter module backplane jumper (one only), connect
- A2P1-65 to A2P1-15 for DIL/DIH
 - A2P1-65 to A2P1-13 for DOL/DOH

A2P1-65 to A2P1-09 for SIO
A2P1-65 to A2P1-05 for AID/SE
A2P1-65 to A2P1-64 for AOD

(b) On the SCU module backplane jumper (one only), connect

A1P1-63 to A1P1-07 for DIL/DIH
A1P1-63 to A1P1-67 for DOL/DOH
A1P1-63 to A1P1-66 for SIO
A1P1-63 to A1P1-49 for AID/SE
A1P1-63 to A1P1-09 for AOD

A.7 To address a particular IOM in the command word use the IOM numbers listed below.

1 - AID/SE
3 - SIO
5 - DOL/DOH
6 - DIL/DIH
8 - AOD

PART B
SAIL MDM TEST PREPARATION
SHEET (TPS NO. 8N9772003)

PLEASE PRESS HARD

| | | | | | | | |
|-----------------------|---|--------------------------|--|--|--------|-----------|-----|
| 1 T Y P E | A | Configuration Change | TEST PREPARATION SHEET NASA LYNDON B JOHNSON SPACE CENTER | 2 | TPS No | 8N9772003 | |
| | B | Non Configuration Change | | X | 3 | S/C | Cat |
| 4 | | | | Mod Sheet Number | | | |
| 6 | | | | S/C No / Model No | | 7 | |
| 7 | | | | Date | | 8 | |
| 10 | | | | Drawings Documents Cops & Part Number(s) | | | |
| 13 | | | | System | | | |
| 15 | | | | TPS Short Title | | | |
| 17 | | | | Reason for Work | | | |
| 18 | | | | DESCRIPTION (Print or Type) | | | |
| 19 | | | | Prepared By | | | |
| 20 | | | | Final Acceptance Date | | | |
| 21 | | | | Tech | | | |
| 22 | | | | CONT | | | |
| 23 | | | | NASA | | | |

11-8-77

11-8-77

11-8-77

07187-0060500-38

Multiplexer/Demultiplexer PN MC614-0004-4100

MDM/SL Serial I/O Interface Test

Test will be performed as part of an ^{ENGINEERING} evaluation of the MDM/Spacelab bus interface unit (BIU) interface.

RC/6 11-9-77

Configure MDM and test equipment as follows (ref. figure 1).

A. Power Interface ~~NB0H14-05PM~~ NB0H14-05PM

1. Connect power cables W34259J10 and W34259J11 to 28 V power supply.

PRIMARY BACKUP

2. Turn on supply, adjust for +28 VDC.

3. Verify that voltage magnitude and polarities on J10 and J11 are as follows:

Pin A = +28VDC + 1.0VDC

Pin B = DC return

Pin C = Signal ground

Pin D = Chassis ground

Pin E = Shield GND

4. After verifying above, turn off supply, connect cable connector J10 to MDM J10 and cable connector J11 to MDM J11.

5. All equipment D.C. returns, signal gnds., chassis ends, and shields are to be tied to +28 VDC return (Pin B).

B. Data Bus Interface

Connect the MDM Data Bus Port Interface Box to MDM (Cont'd)

W. E. Mallary/EG4-NASA

11/9/77

11/8/77

11/8/77

ORIGINAL PAGE IS OF POOR QUALITY

U. S. GOVERNMENT PRINTING OFFICE 1977-271 549
 PLEASE PRESS HARD

| TEST PREPARATION SHEET CONTINUATION SHEET NASA - LYNDON B JOHNSON SPACE CENTER | | TPS NO | 8N9772-003 | |
|--|---|--------|---------------------------|-----------|
| | | MOD NO | | |
| | | ORGAN | PAGE 3 OF 3 | |
| OPER SEQ NO | OPERATIONS (Print Type or Write Legible) | TECH | VERIFICATION CONT NASA | |
| | E. Perform error rate test ^{USING} attached test plan and pro- cedure ^{PER TEST MANAGER INSTRUCTIONS} to verify proper equipment operation. 1. Attach test results (printout) to this TPS. | | | |
| | F. Perform error rate tests with 300 MV PMS noise injected at Micro I/O per section 7 of attached test plan and procedure. 1. Attach test results to this TPS. | | | |
| | G. Perform error rate tests with 300 MV RMS noise injected at MDM end of interface per section 7.0 of attached test plan and procedure. 1. Attach test results to this TPS. | | | |
| | H. Power down MDM and test equipment. | | | |
| | I. Disconnect MDM connectors J ₁ , J ₂ , J ₉ , J ₁₀ , J ₁₁ , J ₁₂ from test equipment. | | | |
| | J. RETURN EQUIPMENT TO R.T. USING TPS | | | 8CDP72001 |
| | K. CLOSE THIS TPS | | | |
| | | | | |
| | | | | |
| | | | | |
| | | | | |
| | | | | |
| | | | | |
| | | | | |
| | | | | |
| | | | | |
| | | | | |

ORIGINAL PAGE IS
OF POOR QUALITY

Doc No. 8N9772003
OFFICIAL COPY

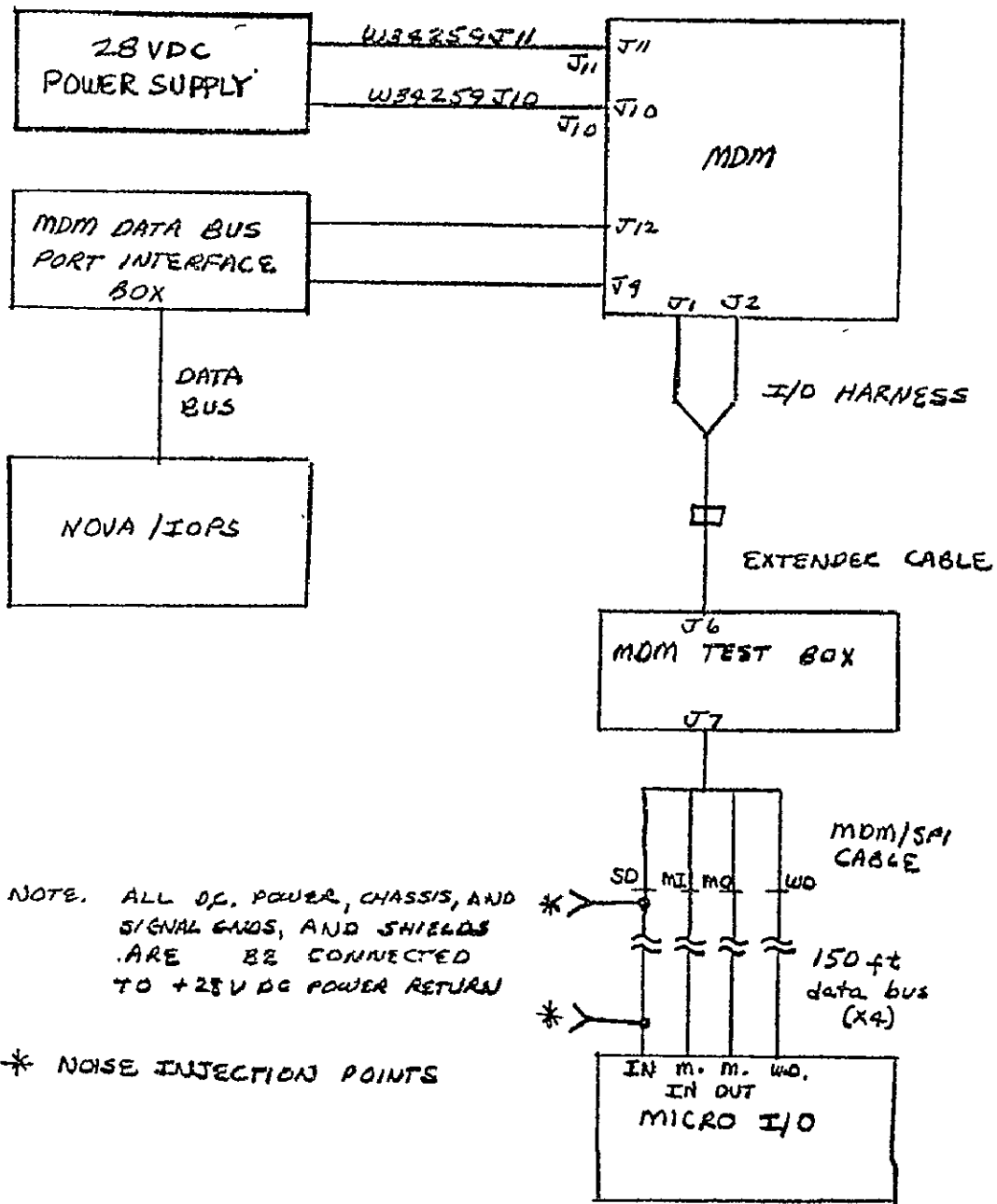

CONFIGURATION DIAGRAM.

Ref to TPS 8N9772003

FIGURE 10

PART C
NOVA/IOPS — MDM/SIO — SL/BIU
DATA TRANSFER TEST
SOFTWARE GUIDE

JSC-13679

N79-12743

NOVA/IOPS - MDM/SIO - SL/BIU

DATA TRANSFER TEST

SOFTWARE GUIDE

JOB ORDER 34-259

Prepared By

Lockheed Electronics Company, Inc.

Systems and Services Division

Houston, Texas

Contract NAS 9-15200

For

CONTROL SYSTEMS DEVELOPMENT DIVISION



National Aeronautics and Space Administration
LYNDON B. JOHNSON SPACE CENTER

Houston, Texas

November 1977

LEC-11407

JSC-13679

NOVA/IOPS - MDM/SIO - SL/BIU

DATA TRANSFER TEST

SOFTWARE GUIDE

JOB ORDER 34-259

PREPARED BY

Frances E. Mount

Frances E. Mount

APPROVED BY

C. R. Murdock

C. R. Murdock, Supervisor
Power and Data Systems Engineering Section

APPROVED BY

S. D. Person

S. D. Person, Manager
Control Systems
Development Department

Prepared By

Lockheed Electronics Company, Inc.

For

Control Systems Development Division

NATIONAL AERONAUTICS AND SPACE ADMINISTRATION
LYNDON B. JOHNSON SPACE CENTER
HOUSTON, TEXAS

November 1977

LEC-11407

| | | | |
|--|---|--|--------------------------------|
| 1 Report No J.S.C. 13679 | 2 Government Accession No | 3 Recipient's Catalog No | |
| 4 Title and Subtitle NOVA/IOPS - MDM/SIO - SL/BIU DATA TRANSFER TEST SOFTWARE GUIDE | | 5 Report Date November 1977 | 6 Performing Organization Code |
| | | 8 Performing Organization Report No LEC-11407 | 10 Work Unit No |
| 7 Author(s) Frances E. Mount | | 9 Performing Organization Name and Address Lockheed Electronics Company, Inc. Systems and Service Division Houston, Texas 77058 | |
| 12 Sponsoring Agency Name and Address NASA/JSC Tech. Monitor: G. T. Rice | | 11 Contract or Grant No NAS 9-15200 | |
| | | 13 Type of Report and Period Covered Data Transfer Test | |
| 15 Supplementary Notes | | 14 Sponsoring Agency Code | |
| 16 Abstract The NOVA/IOPS (Input-Output Processor Simulator) will be used to control all interface testing the CSDD MDM (Multiplexer Demultiplexer) Breadboard SIO IOM (serial input output input module) and the Matra Space Lab Interface Unit (SL/BIU). The software will handle bookkeeping such as word error rates, types of errors, display of error buffers, data display and test identification. | | | |
| 17 Key Words (Suggested by Author(s)) NOVA IOPS (Input-Output Processor Simulator) SL/BIU (Space Lab/Bus Interface Unit) Noisetest | | 18 Distribution Statement | |
| 19 Security Classif (of this report) U | 20 Security Classif (of this page) U | 21 No of Pages 42 | 22 Price* |

*For sale by the National Technical Information Service, Springfield, Virginia 22161

TABLE OF CONTENTS

| Section | Page |
|--|------|
| 1. INTRODUCTION..... | 1-1 |
| 2. PRE-TEST OPTIONS..... | 2-1 |
| 2.1 <u>RESPONSE DATA MODE - TEST 1</u> | 2-1 |
| 2.2 <u>COMMAND DATA MODE - TEST 2</u> | 2-1 |
| 2.3 <u>BITE TEST - TEST 3</u> | 2-2 |
| 3. OPTIONS..... | 3-1 |
| 3.1 <u>BLOCK SIZE (16 or 32)</u> | 3-1 |
| 3.2 <u>HARD COPY PRINTER</u> | 3-1 |
| 3.3 <u>DISPLAY ALL ERRORS</u> | 3-1 |
| 3.4 <u>SIGNAL NOISE RATIO</u> | 3-2 |
| 3.5 <u>NUMBER OF WORD BLOCKS</u> | 3-2 |
| 3.6 <u>CHANNEL NUMBER</u> | 3-2 |
| 3.7 <u>TEST TITLE</u> | 3-2 |
| 3.8 <u>BCE NUMBER</u> | 3-2 |
| 3.9 <u>PROGRAM RESTART</u> | 3-3 |
| 4. OUTPUT DATA FORMAT..... | 4-1 |
| 4.1 <u>INPUT DATA</u> | 4-1 |
| 4.2 <u>ERROR CHECKS</u> | 4-2 |
| 5. DISPLAY..... | 5-1 |
| 5.1 <u>DEFINITION OF DISPLAY</u> | 5-1 |
| 6. REPORT..... | 6-1 |
| 0. INSTRUCTIONS TO LOAD PROGRAM..... | |
| APPENDIX | |
| EXAMPLES | |

APPENDIX

INFORMATION DISPLAY

The following locations can be displayed for additional information, if the Matra Noise Test Program is stopped before completion, or if additional information is desired.

Type:

| | | |
|-----------|---|--|
| ASTAT/ | = | BCE (IOPS) transmit status of last IOPS Program |
| BSTAT/ | = | BCE (IOPS) receive status of last IOPS Program |
| SETS/ | = | Number of sets requested |
| SETNUM/ | = | Current set number |
| NUMBLKS/ | = | Number of blocks requested |
| BLKNUM/ | = | Current block number |
| BCENUM/ | = | BCE numbers requested |
| CHLNO/ | = | Channel number requested |
| HALTFLG/ | = | If set - Program will halt on BCE/IOPS failure status |
| ERRWD/ | = | Total word errors |
| LOGRPT\$R | = | Report will be typed as of current totals - word totals are based on total blocks. |

PRECEDING PAGE BLANK NOT FILLED.
↓
(II)

EXAMPLES

| Example | Page |
|--|------|
| 1 DATA used in NOVA/IOPS - MDM/SIO - SL/BIU Data Transfer Test..... | E-1 |
| 2 Options for Program Restart..... | E-2 |
| 3 Error Display..... | E-3 |
| 4 Total Test with forced "P" Errors..... | E-4 |
| 5 Total Test with forced "G" Errors..... | E-5 |
| 6 Total Test with forced "N" Errors..... | E-6 |
| 7 Total Test with forced "U" Errors..... | E-7 |
| 8 Total Test with forced "O" Errors..... | E-8 |
| 9 Total Test Report with 10 Sets..... (1048544 words) | E-9 |

1. INTRODUCTION

The NOVA/Input Output Processor Simulator (NOVA/IOPS) will be used to control all interface testing between Control Systems Development Division (CSDD) Multiplexer - Demultiplexer (MDM) Breadboard SIO IOM (serial input output input output module) and the MATRA system. All data will be transmitted in 32-word blocks (or 16-word blocks) to the Matra Space Lab Bus Interface Unit (SL/BIU) through the MDM. Each data block will be transmitted to the SL/BIU then requested back and compared with the transmitted data. Each data word will be status tagged.

The BCE status and the tagged status of each word will also be tested. The program will handle bookkeeping such as word error rates, types of errors, display of error buffers, data display, and test identification.

This test is titled "Matranoisetest" and has a starting address designated as .START\$R. The test takes approximately three minutes per million words in the error-free mode.

2. PRE-TEST OPTIONS

A series of pre-tests are possible to test the Serial I/O module. They are tests 4.7.1, 4.7.2, and 4.7.3 of Test Procedures for Multiplexer/Demultiplexer. To start a Pre-Test Type Test1\$R, Test2\$R, or TEST3\$R after loading in program tape. An option is given for the BCE #. Normally #1 is used, though 1, 2, 3, 4, 5, 6, 7, 8 are available in case of failure.

2.1 RESPONSE DATA MODE - TEST 1 (TEST 1\$R)

This test sends 32 words to the NOVA. They are checked for errors and the errors are listed. When the test is completed the computer will "HALT". Hit "CONTINUE" and Test 1 will be rerun. Hit "STOP" then "START" and any test may be chosen to run. To see BCE status for Test 1, at end of test, hit "STOP", "START", and type STAT1/.

2.1.1 To run Test1 the Serial I/O Interface Panel switches should be set as follows:

| | |
|-------------------------------|---------|
| Data Switches 1 to 16 | -Down |
| Address Switches (6 Switches) | -Down |
| Test | -Down |
| - Manual/Memory | -Memory |
| Display in/out | -Out |

2.2 COMMAND DATA TEST MODE - TEST 2 (TEST2\$R)

This test sends 32 words from the NOVA to the MDM. When the test is completed, the computer will "HALT". Hit "CONTINUE" and Test 2 will be rerun. Hit "STOP" then

"START" and any test may be chosen to run. To see BCE status for Test 2; at end of test, hit "STOP", "START" and type STAT1/.

2.2.1 To run Test 2 the Serial I/O Interface Panel switches should be set as follows:

| | |
|-------------------------------|--|
| Data Switches 1 to 16 | -Down |
| Address Switches (6 switches) | -Select the desired data word to be displayed (1-32) |
| Test | -Down |
| Manual/Memory | -Memory |
| Display in/out | -In |

2.3 BITE TEST - TEST 3 (TEST3\$R)

This test provides two response data words. When the test is completed an error message will be displayed in case of error. Computer will "HALT". Hit "CONTINUE" and Test 3 will be rerun. Hit "STOP" then "START" and any test may be chosen to run. To see BCE status for Test 3; at end of test, hit "STOP", "START", and type STAT3/.

3. OPTIONS

Starting the program at its initial address (.START\$R) will initiate a menu display with the following options:

- 16 or 32-word block size -
- Use hard copy printer (Y or N) -
- Halt on IOPS errors (Y or N) -
- Display all errors (Y or N) -
- What is signal noise ratio -
- Number of work blocks -
- Report after each set (Y or N) -
- Select Channel Number (0, 1, 2, or 3)
- Test Title -
- Select BCE Numbers 1, 2, 3, 4, 5, 6, 7, 8 -

See Examples 4 - 8.

3.1 BLOCK SIZE

Block size can be 16 or 32 words.

3.2 HARD COPY PRINTER

Use of the hard copy printer (Matrix), slows the speed of the test because of a delay required. Must have this option if a **hard** copy of the report is desired.

3.2.1 DELAY

A delay is coded into all displays to account for the time needed by the Matrix Printer. If the Matrix Printer will not be used at all the Delay subroutine is no-opted.

3.3 DISPLAY ALL ERRORS

Errors will be logged and totalled and reported in summary report. The display option is used to see where the errors occur, i.e., which word number, which block number, and which order they occur.

3.4 SIGNAL NOISE RATIO

Give numeric value of S/N dB. This option will not accept alpha characters. If no S/N tests are being done, just hit carriage return. Number typed in will be assumed to be dB.

3.5 NUMBER OF WORK BLOCKS

Word blocks are 32 words long (or 16 words). If more than 32767 blocks are requested the words are then counted by sets. There are 32767 blocks in one set. The maximum sets possible in the program is 32767. (i.e. 1048544 words in a set - if used 32 word/block option).

At the conclusion of each set a report is printed with error totals, before starting next set, if requested. If not requested one report will be displayed at the end of the test.

The time to run one set is approximately three minutes, with no errors reported.

3.6 CHANNEL NUMBER

Channel numbers 0, 1, 2, and 3 are available in the Serial I/O. Normally channel "0" is used.

3.7 TEST TITLE

Type appropriate title to designate the test. A carriage return will complete the title input.

3.8 BCE NUMBER

BCE numbers 1,2,3,4,5,6,7,8, are available. Normally #1 is used. This option is in case of a BCE failure.

3.9 PROGRAM RESTART

The program has a restart address (RESTART\$R). At this starting address the only program input requirements will be the number of word blocks for the test, the channel number, test title, and BCE number. Channel 0 and BCE #1 are normally assigned.

See Example 2.

4. OUTPUT DATA FORMAT

The data format reflects a random pattern of bits on the leading four bits and the least significant four bits. This pattern is used to present a varying bit pattern and changing parity. See Example 1.

There are no data words of all zeros and no data word will have the least significant 14 bits of all zeros.

4.1 INPUT DATA

The NOVA/IOPS will transmit to the MATRA System via the MDM a block of 32 (or 16) words. The MATRA System will rebound the last received data block (32 or 16 words). Since each data word receives a status tag the NOVA buffer must start with an even address. The program calculates an even address for the buffer and this address may not match the buffer address in the program listing. In the NOVA buffer the data format will be:

```
      #1  Data
          Status Tag
      #2  Data
          Status Tag
          .
          .
          .
      #32(or #16)  Data
                   Status Tag
```

4.2 ERROR CHECKS

The NOVA/IOPS will receive 66 (or 34) NOVA 16-bit words on each input request.

- 32 data words (or 16 data words)
- 32 data status words - tagged (or 16 status words)
- 2 BCE buffer status words

The program will log errors in the following categories:

- IOPS Status errors
All are displayed - program HALT if requested.
All errors are logged.
- SEV (Data Status logged)
All errors are logged - display if requested.
- Data Receive errors
All errors are logged - display if requested.

A "HALT" will occur if any type error total reaches 500. To get the log report at this time do a "STOP" - "START" and type LOGRPT\$R. If "CONTINUE" is hit after a halt of this type, the error counter will again count to 500 errors. The log report will log 177777₈ errors before it starts over at zero.

4.2.1 IOPS ERRORS (BCE STATUS)

IOPS status errors are failures on the data bus and are not considered as errors in the noise tests. The program checks

for BIT 15 of the status word - GO/NO-GO status. If the status is NO-GO, the status is displayed and the program halted, if halt is requested. The BCE Status Register Format is listed on Page 4-80 of "IOPS Programming and Users Manual".

The BCE status is checked for "transmit" data words from the NOVA, and "receive" data words into the NOVA. The two BCE status words can be checked visibly by hitting "STOP" - "START" and typing,

 ASTAT/ (for NOVA send)
 BSTAT/ (for NOVA receive).

If the program is halted due to IOPS status error it can be restarted by hitting "STOP" - "START" and typing .START\$R, or it can be continued by hitting the "CONTINUE" switch.

4.2.2 SEV Errors (Data Status Tagged)

Input data words passed to the computer will be tagged with the BCE status at the time each word is input.

The "tagged" word is 16 bits immediately following the 16 bit data word. The errors are listed below:

⁰S error = status
 ⁰E error = serial I/O error
 ⁰V error = BITE/Validity error

All status tagged errors will be logged. Each error will be displayed if that option is taken. If no display option is used the total of errors logged will be displayed at the end of the program.

4.2.3 DATA RECEIVE ERRORS

Each data word rebounded by the MATRA System will be compared with the transmitted data word and any bit different will be logged as an error and displayed (if requested).

Data will be compared and any error will be categorized as follows:

| | |
|--------|---|
| 000000 | word not received (no sync) |
| 100000 | parity error |
| 040000 | general or general and parity error |
| 140000 | undefined error |
| xxxxxx | least significant 14 not 0, but data does not compare data error. |

4.2.4 FORCED ERRORS

For testing purposes errors can be forced to appear.

To get errors:

| | |
|-------|----------|
| IOP/R | Open bus |
| S | Open bus |
| E | Open bus |
| V | Open bus |
| D | Open bus |

See Example 3.

Set switches on Serial I/O Tester Panel to Manual, Output,
 and for P set 100...0 in data switches, see Example 4
 for G set 010...0 in data switches, see Example 5
 for N set 000...0 in data switches, see Example 6
 for U set 110...0 in data switches, see Example 7
 for D set xxb'..b in data switches (where at least
 one b ≠ 0 or switch in one of the valid data
 words), see Example 8
 for 31 (or 15) D errors - set switches on Serial I/O
 Tester Panel to Manual, Output and set data
 switches to one valid data word. See Example 8.

Set switches on Serial I/O Tester Panel to Memory Input
 for E and for D.

Reasons these errors occur:

| | |
|-------|--|
| IOP/T | Only occurs on bad IOPS |
| S | Usually first Xfer after the MDM B/B has been powered up. |

4.2.5 ERROR CALCULATIONS

Only one error will be calculated per word as part of the
 "W E R". For instance; if in Word #4 of Block #X, there
 is a data miscompare and a data status tag error, the
 total word errors will be increased only by 1. All individ-
 ual error types will be totalled and logged for display
 in the test report.

$$W E R = \frac{\text{TOTAL WORD ERRORS}}{\text{TOTAL WORDS}}$$

5. DISPLAY

BCE buffer status (IOPS) errors will be displayed if display option is taken or not. If HALT option is requested in IOPS status error, the display will be made before HALT occurs.

All SEV errors will be displayed if display option is taken. Type of error(s), block number, set number, and word number will be displayed.

If display is requested, the display will contain all data receive error words - as they are and as they should be. The block number, set number and word number will be included for reference.

5.1 DEFINITION OF DISPLAY

5.1.1 TYPE

Error types are as follows:

| | |
|-------|------------------------------|
| IOP/R | IOPS "receive" status error |
| IOP/T | IOPS "transmit" status error |
| D | Data error |
| P | Parity error |
| G | General error |
| N | No sync error |
| U | Undefined error |
| S | Status error |
| E | Serial I/O error |
| V | Bite/Validity error |

See Examples 3, 4, 5, 6, 7, 8.

5.1.2 The statement "Line Paper Up In Printer and Hit Carriage Return" is there to enable the error listing to start at the top of a page.

6. REPORT

6.1 At the conclusion of each test, a summary will be displayed on the matrix printer, the display will include:

- Test Title
 - Channel Requested
 - Sets Requested
 - Current Set
 - Blocks Requested
 - Current Blocks
 - Signal Noise Ratio
 - Logged Totals Of:
 - Total Word Errors
 - Parity Errors '
 - General Errors
 - No Sync Errors
 - Undefined Errors
 - Data Errors
 - S Errors
 - E Errors
 - V Errors
 - BCE (IOPS) Errors
- See Examples 4a, 5a, 6a, 7a, 8a
- WER
 - Total Number of Words Used

6.2 At any time the summary report can be obtained by hitting "STOP/START" and typing LOGRPT\$R on CRT. But the WER reflects number of blocks and not actual number of words, if stopped in the middle of a block.

- 0.0 INSTRUCTIONS TO USE SOFTWARE (LOADING)
If program is in the computer start with 0.6.
- 0.1 Turn on Main Power for both systems; cassette and computer
Turn on individual power:
0.1.0 cassette holder
0.1.1 CRT
0.1.2 Matrix printer
0.1.3 Computer/IOPS System (usually # 3)
- 0.2 Place tape in cassette holder #0
Use left-most one make sure only one is designated "0"
- 0.3 Put "3" in wheel on Cassette Interface Control Unit
(use "2" if NOVA/IOPS System # 2)
- 0.4 Put 100034 in switches of NOVA (in IOPS system)
Do STOP/RESET/PROGRAM LOAD
- 0.5 A # will appear on CRT
Respond with a "1" and a carriage return. Program
will load into NOVA.
- 0.6 When load is finished, put 14367* in NOVA switches, do
STOP/RESET/START.
- 0.7 On CRT type desired program;
.START\$R gives NOISE TEST
TEST1\$R gives Response Data Mode Diagnostic
TEST2\$R gives Command Data Mode Diagnostic
TEST3\$R gives MDM BITE Test

*This address will change every time the program is changed
and re-assembled.

0.8 After tape is loaded - Rewind.

EXAMPLES

DATA

WD

Parity

| | | | |
|----|-------------------------------------|-------------|---|
| 1 | { 1 0 0 0 0 0 0 0 0 0 0 0 0 0 0 0 1 | 1 0 0 0 0 1 | 1 |
| 2 | { 0 1 1 1 1 1 1 1 1 1 1 1 1 1 1 0 | 0 7 7 7 7 6 | 1 |
| 3 | { 0 1 0 0 0 0 1 1 1 0 0 0 0 0 1 0 | 0 4 1 6 0 2 | 0 |
| 4 | { 1 0 1 1 1 1 0 0 0 1 1 1 1 1 0 1 | 1 3 6 1 7 5 | 0 |
| 5 | { 1 1 0 0 0 0 1 1 1 1 0 0 0 0 1 1 | 1 4 1 7 0 3 | 1 |
| 6 | { 0 0 1 1 1 1 0 0 0 0 1 1 1 1 0 0 | 0 3 6 0 7 4 | 1 |
| 7 | { 0 0 1 0 0 0 1 1 1 0 0 0 0 1 0 0 | 0 2 1 6 0 4 | 0 |
| 8 | { 1 1 0 1 1 1 0 0 0 1 1 1 1 0 1 1 | 1 5 6 1 7 3 | 0 |
| 9 | { 1 0 1 0 0 0 1 1 1 1 0 0 0 1 0 1 | 1 2 1 7 0 5 | 1 |
| 10 | { 0 1 0 1 1 1 0 0 0 0 1 1 1 0 1 0 | 0 5 6 0 7 2 | 1 |
| 11 | { 0 1 1 0 0 0 0 0 0 0 1 1 1 1 1 0 | 0 6 0 0 7 6 | 0 |
| 12 | { 1 0 0 1 1 1 1 1 1 1 0 0 0 0 0 1 | 1 1 7 7 0 1 | 0 |
| 13 | { 1 1 1 0 0 0 0 1 1 0 0 0 0 1 1 1 | 1 6 0 6 0 7 | 1 |
| 14 | { 0 0 0 1 1 1 1 0 0 1 1 1 1 0 0 0 | 0 1 7 1 7 0 | 1 |
| 15 | { 0 0 0 1 0 0 0 0 1 0 0 0 1 0 0 0 | 0 1 0 2 1 0 | 0 |
| 16 | { 1 1 1 0 1 1 1 1 0 1 1 1 0 1 1 1 | 1 6 7 5 6 7 | 0 |
| 17 | { 1 0 0 1 0 0 0 0 0 0 0 0 1 0 0 1 | 1 1 0 0 1 1 | 1 |
| 18 | { 0 1 1 0 1 1 1 1 1 1 1 0 1 1 1 0 | 0 6 7 7 6 6 | 1 |
| 19 | { 0 1 0 1 0 0 0 1 1 1 0 0 1 0 1 0 | 0 5 0 7 1 2 | 0 |
| 20 | { 1 0 1 0 1 1 1 0 0 0 1 1 0 1 0 1 | 1 2 7 0 6 5 | 0 |
| 21 | { 1 1 0 1 0 0 0 0 0 0 0 0 1 0 1 1 | 1 5 0 0 7 3 | 1 |
| 22 | { 0 0 1 0 1 1 1 1 1 1 1 1 0 1 0 0 | 0 2 7 7 6 4 | 1 |
| 23 | { 0 0 1 1 0 0 0 1 1 1 0 0 1 1 0 0 | 0 3 0 7 1 4 | 0 |
| 24 | { 1 1 0 0 1 1 1 0 0 0 1 1 0 0 1 1 | 1 4 7 0 6 3 | 0 |
| 25 | { 1 0 1 1 0 0 0 0 0 0 0 0 1 1 0 1 | 1 3 0 0 1 5 | 1 |
| 26 | { 0 1 0 0 1 1 1 1 1 1 1 1 0 0 1 0 | 0 4 7 7 6 2 | 1 |
| 27 | { 0 1 1 1 0 0 1 1 1 0 0 0 1 1 1 0 | 0 7 1 6 1 6 | 0 |
| 28 | { 1 0 0 0 1 1 0 0 0 1 1 1 0 0 0 1 | 1 0 6 1 6 1 | 0 |
| 29 | { 1 1 1 1 0 0 0 1 1 0 0 0 1 1 1 1 | 1 7 0 6 1 7 | 1 |
| 30 | { 0 0 0 0 1 1 1 0 0 1 1 1 0 0 0 0 | 0 0 7 1 6 0 | 1 |
| 31 | { 0 0 0 0 1 0 0 1 0 0 0 1 0 0 0 0 | 0 0 4 4 2 0 | 0 |
| 32 | { 1 1 1 1 0 1 1 0 1 1 1 0 1 1 1 1 | 1 7 3 3 5 7 | 0 |

BLOCKS ARE 16 WORDS LONG
REQUEST MORE THAN 32767 BLOCKS? (Y OR N) - N

NUMBER OF (16-WORD) BLOCKS REQUESTED?
(1 TO 32767) - 1

SELECT CHANNEL NUMBER (0, 1, 2, OR 3) 0

TYPE TEST TITLE - - KEEP IT SHORT
DEMONSTRATION OF RESTART -

SELECT BCE NUMBER 1, 2, 3, 4, 5, 6, 7, 8 - 1

LINE PAPER UP IN PRINTER AND HIT CARRIAGE RETURN

ORIGINAL PAGE IS
OF POOR QUALITY

| - ERROR DISPLAY - | | | SET | CORRECT | REC. | STATUS |
|-------------------|------|-------|-----|---------|--------|--------|
| TYPE | WORD | BLOCK | | | | |
| IOP/R | | 1 | 0 | | | 000037 |
| D | 1 | 1 | 0 | 100001 | 177777 | |
| V | 1 | 1 | 0 | | | |
| E | 1 | 1 | 0 | | | |
| S | 1 | 1 | 0 | | | |
| D | 2 | 1 | 0 | 077776 | 177777 | |
| V | 2 | 1 | 0 | | | |
| E | 2 | 1 | 0 | | | |
| S | 2 | 1 | 0 | | | |
| D | 3 | 1 | 0 | 041602 | 177777 | |
| V | 3 | 1 | 0 | | | |
| E | 3 | 1 | 0 | | | |
| S | 3 | 1 | 0 | | | |
| D | 4 | 1 | 0 | 136175 | 177777 | |
| V | 4 | 1 | 0 | | | |
| E | 4 | 1 | 0 | | | |
| S | 4 | 1 | 0 | | | |
| D | 5 | 1 | 0 | 141703 | 177777 | |
| V | 5 | 1 | 0 | | | |
| E | 5 | 1 | 0 | | | |
| S | 5 | 1 | 0 | | | |
| D | 6 | 1 | 0 | 036074 | 177777 | |
| V | 6 | 1 | 0 | | | |
| E | 6 | 1 | 0 | | | |
| S | 6 | 1 | 0 | | | |
| D | 7 | 1 | 0 | 021604 | 177777 | |
| V | 7 | 1 | 0 | | | |
| E | 7 | 1 | 0 | | | |
| S | 7 | 1 | 0 | | | |
| D | 8 | 1 | 0 | 156173 | 177777 | |
| V | 8 | 1 | 0 | | | |
| E | 8 | 1 | 0 | | | |
| S | 8 | 1 | 0 | | | |
| D | 9 | 1 | 0 | 121705 | 177777 | |
| V | 9 | 1 | 0 | | | |
| E | 9 | 1 | 0 | | | |
| S | 9 | 1 | 0 | | | |
| D | 10 | 1 | 0 | 056072 | 177777 | |
| V | 10 | 1 | 0 | | | |
| E | 10 | 1 | 0 | | | |
| S | 10 | 1 | 0 | | | |
| D | 11 | 1 | 0 | 060076 | 177777 | |
| V | 11 | 1 | 0 | | | |
| E | 11 | 1 | 0 | | | |
| S | 11 | 1 | 0 | | | |
| D | 12 | 1 | 0 | 117701 | 177777 | |
| V | 12 | 1 | 0 | | | |
| E | 12 | 1 | 0 | | | |
| S | 12 | 1 | 0 | | | |
| D | 13 | 1 | 0 | 160607 | 177777 | |
| V | 13 | 1 | 0 | | | |
| E | 13 | 1 | 0 | | | |
| S | 13 | 1 | 0 | | | |
| D | 14 | 1 | 0 | 017170 | 177777 | |
| V | 14 | 1 | 0 | | | |
| E | 14 | 1 | 0 | | | |
| S | 14 | 1 | 0 | | | |
| D | 15 | 1 | 0 | 010210 | 177777 | |
| V | 15 | 1 | 0 | | | |
| E | 15 | 1 | 0 | | | |

ORIGINAL PAGE IS
OF POOR QUALITY

START\$R

USE CARRIAGE RETURN AFTER RESPONSE''

16- OR 32-WORD BLOCK SIZE? - 16

USE HARD COPY PRINTER? (Y OR N) - Y

HALT ON IOPS ERROR? (Y OR N) - N

DISPLAY ALL ERRORS? (Y OR N) - Y

WHAT IS SIGNAL NOISE RATIO? -

BLOCKS ARE 16 WORDS LONG

REQUEST MORE THAN 32767 BLOCKS? (Y OR N) - N

NUMBER OF (16-WORD) BLOCKS REQUESTED?
(1 TO 32767) - 1

SELECT CHANNEL NUMBER (0,1,2, OR 3) 0

TYPE TEST TITLE - - KEEP IT SHORT
TEST 'P' ERROR

SELECT BCE NUMBER 1,2,3,4,5,6,7,8 - 1

LINE PAPER UP IN PRINTER AND HIT CARRRIAGE RETURN

- ERROR DISPLAY -

| TYPE | WORD | BLOCK | SET | CORRECT | REC. | STATUS |
|------|------|-------|-----|---------|--------|--------|
| P | 1 | 1 | 0 | 100001 | 100000 | |
| P | 2 | 1 | 0 | 077776 | 100000 | |
| P | 3 | 1 | 0 | 041602 | 100000 | |
| P | 4 | 1 | 0 | 136175 | 100000 | |
| P | 5 | 1 | 0 | 141703 | 100000 | |
| P | 6 | 1 | 0 | 036074 | 100000 | |
| P | 7 | 1 | 0 | 021604 | 100000 | |
| P | 8 | 1 | 0 | 156173 | 100000 | |
| P | 9 | 1 | 0 | 121705 | 100000 | |
| P | 10 | 1 | 0 | 056072 | 100000 | |
| P | 11 | 1 | 0 | 060076 | 100000 | |
| P | 12 | 1 | 0 | 117701 | 100000 | |
| P | 13 | 1 | 0 | 160607 | 100000 | |
| P | 14 | 1 | 0 | 017170 | 100000 | |
| P | 15 | 1 | 0 | 010210 | 100000 | |
| P | 16 | 1 | 0 | 167567 | 100000 | |

TEST 'P' ERROR

REPORT
 CHANNEL 0 REQUESTED
 0 SETS REQUESTED
 0 CURRENT SET
 1 BLOCKS REQUESTED
 1 CURRENT BLOCK
 SIGNAL NOISE RATIO GIVEN AS 0

ORIGINAL PAGE IS
 OF POOR QUALITY

ERROR TOTALS :

TOTAL WORD ERRORS 16

 PARITY ERRORS 16
 GENERAL ERRORS 0
 NO SYNC ERRORS 0
 UNDEFINED ERRORS 0
 DATA ERRORS 0
 'S' WORD STATUS ERRORS 0
 'E' SERIAL I/O ERRORS 0
 'V' BIT VALIDITY ERRORS 0
 BCE (IOPS) ERRORS 0

W E R
 + 1000000E+01

TOTAL NUMBER OF WORDS USED IN 'W E R'
 +. 1600000E+02

. START\$R

USE CARRIAGE RETURN AFTER RESPONSE!!

16- OR 32-WORD BLOCK SIZE? - 16

USE HARD COPY PRINTER? (Y OR N) - Y

HALT ON IOPS ERROR? (Y OR N) - N

DISPLAY ALL ERRORS? (Y OR N) - Y

WHAT IS SIGNAL NOISE RATIO? -

BLOCKS ARE 16 WORDS LONG

REQUEST MORE THAN 32767 BLOCKS? (Y OR N) - N

NUMBER OF (16-WORD) BLOCKS REQUESTED?
(1 TO 32767) - 1

SELECT CHANNEL NUMBER (0, 1, 2, OR 3) 0

TYPE TEST TITLE - - KEEP IT SHORT
TEST 'G' ERROR

SELECT BCE NUMBER 1, 2, 3, 4, 5, 6, 7, 8 - 1

LINE PAPER UP IN PRINTER AND HIT CARRIAGE RETURN

- ERROR DISPLAY -

| TYPE | WORD | BLOCK | SET | CORRECT | REC. | STATUS |
|------|------|-------|-----|---------|--------|--------|
| G | 1 | 1 | 0 | 100001 | 040000 | |
| G | 2 | 1 | 0 | 077776 | 040000 | |
| G | 3 | 1 | 0 | 041602 | 040000 | |
| G | 4 | 1 | 0 | 136175 | 040000 | |
| G | 5 | 1 | 0 | 141703 | 040000 | |
| G | 6 | 1 | 0 | 036074 | 040000 | |
| G | 7 | 1 | 0 | 021604 | 040000 | |
| G | 8 | 1 | 0 | 156173 | 040000 | |
| G | 9 | 1 | 0 | 121705 | 040000 | |
| G | 10 | 1 | 0 | 056072 | 040000 | |
| G | 11 | 1 | 0 | 060076 | 040000 | |
| G | 12 | 1 | 0 | 117701 | 040000 | |
| G | 13 | 1 | 0 | 160607 | 040000 | |
| G | 14 | 1 | 0 | 017170 | 040000 | |
| G | 15 | 1 | 0 | 010210 | 040000 | |
| G | 16 | 1 | 0 | 167567 | 040000 | |

ORIGINAL PAGE IS
OF POOR QUALITY

TEST 'G' ERROR

REPORT.
CHANNEL 0 REQUESTED
0 SETS REQUESTED
0 CURRENT SET
1 BLOCKS REQUESTED
1 CURRENT BLOCK
SIGNAL NOISE RATIO GIVEN AS 0

ERROR TOTALS :

| | |
|-------------------------|----|
| TOTAL WORD ERRORS | 16 |
| ----- | |
| PARITY ERRORS | 0 |
| GENERAL ERRORS | 16 |
| NO SYNC ERRORS | 0 |
| UNDEFINED ERRORS | 0 |
| DATA ERRORS | 0 |
| 'S' WORD STATUS ERRORS | 0 |
| 'E' SERIAL I/O ERRORS | 0 |
| 'V' BIT VALIDITY ERRORS | 0 |
| BCE (IOPS) ERRORS | 0 |

W E R .
+ 1000000E+01

TOTAL NUMBER OF WORDS USED IN 'W E R'
+ 1600000E+02

C-2

. START\$R

USE CARRIAGE RETURN AFTER RESPONSE!!

16- OR 32-WORD BLOCK SIZE? - 16

USE HARD COPY PRINTER? (Y OR N) - Y

HALT ON IOPS ERROR? (Y OR N) - N

DISPLAY ALL ERRORS? (Y OR N) - Y

WHAT IS SIGNAL NOISE RATIO? -

BLOCKS ARE 16 WORDS LONG

REQUEST MORE THAN 32767 BLOCKS? (Y OR N) - N

NUMBER OF (16-WORD) BLOCKS REQUESTED?
(1 TO 32767) - 1

SELECT CHANNEL NUMBER (0, 1, 2, OR 3) 0

TYPE TEST TITLE - - KEEP IT SHORT
TEST 'N' ERROR

SELECT BCE NUMBER 1, 2, 3, 4, 5, 6, 7, 8 - 1

LINE PAPER UP IN PRINTER AND HIT CARRIAGE RETURN

- ERROR DISPLAY -

| TYPE | WORD | BLOCK | SET | CORRECT | REC. | STATUS |
|------|------|-------|-----|---------|--------|--------|
| N | 1 | 1 | 0 | 100001 | 000000 | |
| N | 2 | 1 | 0 | 077776 | 000000 | |
| N | 3 | 1 | 0 | 041602 | 000000 | |
| N | 4 | 1 | 0 | 136175 | 000000 | |
| N | 5 | 1 | 0 | 141703 | 000000 | |
| N | 6 | 1 | 0 | 036074 | 000000 | |
| N | 7 | 1 | 0 | 021604 | 000000 | |
| N | 8 | 1 | 0 | 156173 | 000000 | |
| N | 9 | 1 | 0 | 121705 | 000000 | |
| N | 10 | 1 | 0 | 056072 | 000000 | |
| N | 11 | 1 | 0 | 060076 | 000000 | |
| N | 12 | 1 | 0 | 117701 | 000000 | |
| N | 13 | 1 | 0 | 160607 | 000000 | |
| N | 14 | 1 | 0 | 017170 | 000000 | |
| N | 15 | 1 | 0 | 010210 | 000000 | |
| N | 16 | 1 | 0 | 167567 | 000000 | |

TEST 'N' ERROR

REPORT:
CHANNEL 0 REQUESTED
0 SETS REQUESTED
0 CURRENT SET
1 BLOCKS REQUESTED
1 CURRENT BLOCK
SIGNAL NOISE RATIO GIVEN AS .0

ERROR TOTALS .

TOTAL WORD ERRORS 16

PARITY ERRORS 0
GENERAL ERRORS 0
NO SYNC ERRORS 16
UNDEFINED ERRORS 0
DATA ERRORS 0
'S' WORD STATUS ERRORS 0
'E' SERIAL I/O ERRORS 0
'V' BIT VALIDITY ERRORS 0
BCE (IOPS) ERRORS 0

W E R
+.1000000E+01

TOTAL NUMBER OF WORDS USED IN 'W E R'
+ 1600000E+02

. START#R

USE CARRIAGE RETURN AFTER RESPONSE!!

16- OR 32-WORD BLOCK SIZE? - 16

USE HARD COPY PRINTER? (Y OR N) - Y

HALT ON IOPS ERROR? (Y OR N) - Y

DISPLAY ALL ERRORS? (Y OR N) - Y

WHAT IS SIGNAL NOISE RATIO? -

BLOCKS ARE 16 WORDS LONG

REQUEST MORE THAN 32767 BLOCKS? (Y OR N) - N

NUMBER OF (16-WORD) BLOCKS REQUESTED?
(1 TO 32767) - 1

SELECT CHANNEL NUMBER (0, 1, 2, OR 3) 0

TYPE TEST TITLE - - KEEP IT SHORT
TEST 'U' ERROR

SELECT BCE NUMBER 1, 2, 3, 4, 5, 6, 7, 8 - 1

LINE PAPER UP IN PRINTER AND HIT CARRIAGE RETURN

- ERROR DISPLAY -

| TYPE | WORD | BLOCK | SET | CORRECT | REC. | STATUS |
|------|------|-------|-----|---------|--------|--------|
| U | 1 | 1 | 0 | 100001 | 140000 | |
| U | 2 | 1 | 0 | 077776 | 140000 | |
| U | 3 | 1 | 0 | 041602 | 140000 | |
| U | 4 | 1 | 0 | 136175 | 140000 | |
| U | 5 | 1 | 0 | 141703 | 140000 | |
| U | 6 | 1 | 0 | 036074 | 140000 | |
| U | 7 | 1 | 0 | 021604 | 140000 | |
| U | 8 | 1 | 0 | 156173 | 140000 | |
| U | 9 | 1 | 0 | 121705 | 140000 | |
| U | 10 | 1 | 0 | 056072 | 140000 | |
| U | 11 | 1 | 0 | 060076 | 140000 | |
| U | 12 | 1 | 0 | 117701 | 140000 | |
| U | 13 | 1 | 0 | 160607 | 140000 | |
| U | 14 | 1 | 0 | 017170 | 140000 | |
| U | 15 | 1 | 0 | 010210 | 140000 | |
| U | 16 | 1 | 0 | 167567 | 140000 | |

TEST 'U' ERROR

REPORT

CHANNEL 0 REQUESTED
 0 SETS REQUESTED
 0 CURRENT SET
 1 BLOCKS REQUESTED
 1 CURRENT BLOCK
 SIGNAL NOISE RATIO GIVEN AS 0

ERROR TOTALS :

TOTAL WORD ERRORS 16

 PARITY ERRORS 0
 GENERAL ERRORS 0
 NO SYNC ERRORS 0
 UNDEFINED ERRORS 16
 DATA ERRORS 0
 'S' WORD STATUS ERRORS 0
 'E' SERIAL I/O ERRORS 0
 'V' BIT VALIDITY ERRORS 0
 BCE (IOPS) ERRORS 0

W E R .
 +. 1000000E+01

TOTAL NUMBER OF WORDS USED IN 'W E R'
 +. 1600000E+02

START\$R

USE CARRIAGE RETURN AFTER RESPONSE!!

16- OR 32-WORD BLOCK SIZE? - 16

USE HARD COPY PRINTER? (Y OR N) - Y

HALT ON IOPS ERROR? (Y OR N) - N

DISPLAY ALL ERRORS? (Y OR N) - Y

WHAT IS SIGNAL NOISE RATIO? -

BLOCKS ARE 16 WORDS LONG

REQUEST MORE THAN 32767 BLOCKS? (Y OR N) - N

NUMBER OF (16-WORD) BLOCKS REQUESTED?
(1 TO 32767) - 1

SELECT CHANNEL NUMBER (0, 1, 2, OR 3) 0

TYPE TEST TITLE - - KEEP IT SHORT
FORCE 15 DATA ERRORS

SELECT BCE NUMBER 1, 2, 3, 4, 5, 6, 7, 8 - 1

LINE PAPER UP IN PRINTER AND HIT CARRIAGE RETURN

| - ERROR DISPLAY - | | | | | | |
|-------------------|------|-------|-----|---------|--------|--------|
| TYPE | WORD | BLOCK | SET | CORRECT | REC. | STATUS |
| D | 1 | 1 | 0 | 100001 | 136175 | |
| D | 2 | 1 | 0 | 077776 | 136175 | |
| D | 3 | 1 | 0 | 041602 | 136175 | |
| D | 5 | 1 | 0 | 141703 | 136175 | |
| D | 6 | 1 | 0 | 036074 | 136175 | |
| D | 7 | 1 | 0 | 021604 | 136175 | |
| D | 8 | 1 | 0 | 156173 | 136175 | |
| D | 9 | 1 | 0 | 121705 | 136175 | |
| D | 10 | 1 | 0 | 056072 | 136175 | |
| D | 11 | 1 | 0 | 060076 | 136175 | |
| D | 12 | 1 | 0 | 117701 | 136175 | |
| D | 13 | 1 | 0 | 160607 | 136175 | |
| D | 14 | 1 | 0 | 017170 | 136175 | |
| D | 15 | 1 | 0 | 010210 | 136175 | |
| D | 16 | 1 | 0 | 167567 | 136175 | |

FORCE 15 DATA ERRORS

REPORT
CHANNEL 0 REQUESTED
0 SETS REQUESTED
0 CURRENT SET
1 BLOCKS REQUESTED
1 CURRENT BLOCK
SIGNAL NOISE RATIO GIVEN AS 0

ERROR TOTALS

TOTAL WORD ERRORS 15

PARITY ERRORS 0
GENERAL ERRORS 0
NO SYNC ERRORS 0
UNDEFINED ERRORS 0
DATA ERRORS 15
'S' WORD STATUS ERRORS 0
'E' SERIAL I/O ERRORS 0
'V' BIT VALIDITY ERRORS 0
BCE (IOPS) ERRORS 0

W E R :
+ 9375000E+00

TOTAL NUMBER OF WORDS USED IN 'W E R'
+ 1600000E+02

FINAL TEST. ..!!!!!!!

REPORT
CHANNEL 0 REQUESTED
10 SETS REQUESTED
1 CURRENT SET
0 BLOCKS REQUESTED
32767 CURRENT BLOCK
SIGNAL NOISE RATIO GIVEN AS 5

ERROR TOTALS

| | |
|-------------------------|-----|
| TOTAL WORD ERRORS | 182 |
| ----- | |
| PARITY ERRORS | 32 |
| GENERAL ERRORS | 0 |
| NO SYNC ERRORS | 32 |
| UNDEFINED ERRORS | 32 |
| DATA ERRORS | 86 |
| 'S' WORD STATUS ERRORS | 0 |
| 'E' SERIAL I/O ERRORS | 22 |
| 'V' BIT VALIDITY ERRORS | 0 |
| BCE (IOPS) ERRORS | 1 |

W E R .
+. 1735740E-03

TOTAL NUMBER OF WORDS USED IN 'W E R'
+. 1048544E+07

FINAL TEST... .!!!!!!!

ORIGINAL PAGE IS
OF POOR QUALITY

```

REPORT·
CHANNEL  0  REQUESTED
      10  SETS REQUESTED
      2   CURRENT SET
      0   BLOCKS REQUESTED
32767   CURRENT BLOCK
SIGNAL NOISE RATIO GIVEN AS      5

```

ERROR TOTALS :

```

TOTAL WORD ERRORS      182
-----

```

```

PARITY ERRORS      32
GENERAL ERRORS     0
NO SYNC ERRORS    32
UNDEFINED ERRORS  32
DATA ERRORS                               86
'S' WORD STATUS ERRORS      0
'E' SERIAL I/O ERRORS      22
'V' BIT VALIDITY ERRORS     0
BCE (IOPS) ERRORS          1

```

W E R ·
+ .8678704E-04

TOTAL NUMBER OF WORDS USED IN 'W E R'
+ 2097088E+07

FINAL TEST... .!!!!!!!

```

REPORT·
CHANNEL  0  REQUESTED
      10  SETS REQUESTED
      3   CURRENT SET
      0   BLOCKS REQUESTED
32767   CURRENT BLOCK
SIGNAL NOISE RATIO GIVEN AS      5

```

ERROR TOTALS :

```

TOTAL WORD ERRORS      182
-----

```

```

PARITY ERRORS      32
GENERAL ERRORS     0
NO SYNC ERRORS    32
UNDEFINED ERRORS  32
DATA ERRORS                               86
'S' WORD STATUS ERRORS      0
'E' SERIAL I/O ERRORS      22
'V' BIT VALIDITY ERRORS     0
BCE (IOPS) ERRORS          1

```

W E R :
+ 5785900E-04

TOTAL NUMBER OF WORDS USED IN 'W E R'
+ 3145632E+07

FINAL TEST... !!!!!!!!

REPORT.
CHANNEL 0 REQUESTED
10 SETS REQUESTED
4 CURRENT SET
0 BLOCKS REQUESTED
32767 CURRENT BLOCK
SIGNAL NOISE RATIO GIVEN AS 5

ERROR TOTALS :

TOTAL WORD ERRORS 182

PARITY ERRORS 32
GENERAL ERRORS 0
NO SYNC ERRORS 32
UNDEFINED ERRORS 32
DATA ERRORS 86
'S' WORD STATUS ERRORS 0
'E' SERIAL I/O ERRORS 22
'V' BIT VALIDITY ERRORS 0
BCE (IOPS) ERRORS 1

W E R
+. 4339351E-04

TOTAL NUMBER OF WORDS USED IN 'W-E R'
+. 4194176E+07

FINAL TEST... !!!!!!!!

REPORT.
CHANNEL 0 REQUESTED
10 SETS REQUESTED
5 CURRENT SET
0 BLOCKS REQUESTED
32767 CURRENT BLOCK
SIGNAL NOISE RATIO GIVEN AS 5

ERROR TOTALS

TOTAL WORD ERRORS 182

PARITY ERRORS 32
GENERAL ERRORS 0
NO SYNC ERRORS 32
UNDEFINED ERRORS 32
DATA ERRORS 86
'S' WORD STATUS ERRORS 0
'E' SERIAL I/O ERRORS 22
'V' BIT VALIDITY ERRORS 0
BCE (IOPS) ERRORS 1

W E R
+ 3471480E-04

TOTAL NUMBER OF WORDS USED IN 'W E R'
+. 5242720E+07

FINAL TEST.....!!!!!!!!!!

REPORT.
 CHANNEL 0 REQUESTED
 10 SETS REQUESTED
 6 CURRENT SET
 0 BLOCKS REQUESTED
 32767 CURRENT BLOCK
 SIGNAL NOISE RATIO GIVEN AS 5

ORIGINAL PAGE IS
OF POOR QUALITY

ERROR TOTALS :

| | |
|-------------------------|-----|
| TOTAL WORD ERRORS | 182 |
| ----- | |
| PARITY ERRORS | 32 |
| GENERAL ERRORS | 0 |
| NO SYNC ERRORS | 32 |
| UNDEFINED ERRORS | 32 |
| DATA ERRORS | 86 |
| 'S' WORD STATUS ERRORS | 0 |
| 'E' SERIAL I/O ERRORS | 22 |
| 'V' BIT VALIDITY ERRORS | 0 |
| BCE (IOPS) ERRORS | 1 |

W E R :
+. 2892900E-04

TOTAL NUMBER OF WORDS USED IN 'W E R'
+ 6291264E+07

FINAL TEST . .!!!!!!!!!!

REPORT.
 CHANNEL 0 REQUESTED
 10 SETS REQUESTED
 7 CURRENT SET
 0 BLOCKS REQUESTED
 32767 CURRENT BLOCK
 SIGNAL NOISE RATIO GIVEN AS 5

ERROR TOTALS :

| | |
|-------------------------|-----|
| TOTAL WORD ERRORS | 182 |
| ----- | |
| PARITY ERRORS | 32 |
| GENERAL ERRORS | 0 |
| NO SYNC ERRORS | 32 |
| UNDEFINED ERRORS | 32 |
| DATA ERRORS | 86 |
| 'S' WORD STATUS ERRORS | 0 |
| 'E' SERIAL I/O ERRORS | 22 |
| 'V' BIT VALIDITY ERRORS | 0 |
| BCE (IOPS) ERRORS | 1 |

W E R :
+. 2479628E-04

TOTAL NUMBER OF WORDS USED IN 'W E R'
+ 7339807E+07

FINAL TEST....!!!!!!!

```

REPORT·
CHANNEL  0  REQUESTED
  10     SETS REQUESTED
   8     CURRENT SET
   0     BLOCKS REQUESTED
32767    CURRENT BLOCK
SIGNAL NOISE RATIO GIVEN AS      5

```

ERROR TOTALS :

```

TOTAL WORD ERRORS      182
-----
PARITY ERRORS          32
GENERAL ERRORS         0
NO SYNC ERRORS        32
UNDEFINED ERRORS      32
DATA ERRORS                                86
'S' WORD STATUS ERRORS  0
'E' SERIAL I/O ERRORS  22
'V' BIT VALIDITY ERRORS  0
BCE <IOPS> ERRORS      1

```

W E R :
+ 2169674E-04

TOTAL NUMBER OF WORDS USED IN 'W E R'
+. 8388351E+07

FINAL TEST.. .!!!!!!!

```

REPORT·
CHANNEL  0  REQUESTED
  10     SETS REQUESTED
   9     CURRENT SET
   0     BLOCKS REQUESTED
32767    CURRENT BLOCK
SIGNAL NOISE RATIO GIVEN AS      5

```

ERROR TOTALS :

```

TOTAL WORD ERRORS      182
-----
PARITY ERRORS          32
GENERAL ERRORS         0
NO SYNC ERRORS        32
UNDEFINED ERRORS      32
DATA ERRORS                                86
'S' WORD STATUS ERRORS  0
'E' SERIAL I/O ERRORS  22
'V' BIT VALIDITY ERRORS  0
BCE <IOPS> ERRORS      1

```

W E R :
+. 1928600E-04

TOTAL NUMBER OF WORDS USED IN 'W E R'
+. 9436896E+07

ORIGINAL PAGE IS
- 200R QUALITY

FINAL TEST.....!!!!!!!!!!

REPORT:
CHANNEL 0 REQUESTED
10 SETS REQUESTED
10 CURRENT SET
0 BLOCKS REQUESTED
32767 CURRENT BLOCK
SIGNAL NOISE RATIO GIVEN AS 5

ERROR TOTALS :

TOTAL WORD ERRORS 182

| | |
|-------------------------|----|
| PARITY ERRORS | 32 |
| GENERAL ERRORS | 0 |
| NO SYNC ERRORS | 32 |
| UNDEFINED ERRORS | 32 |
| DATA ERRORS | 86 |
| 'S' WORD STATUS ERRORS | 0 |
| 'E' SERIAL I/O ERRORS | 22 |
| 'V' BIT VALIDITY ERRORS | 0 |
| BCE (IOPS) ERRORS | 1 |

W E R :
+. 1735739E-04

^ TOTAL NUMBER OF WORDS USED IN 'W·E R'
+. 1048544E+08
