

NASA Conference Publication 2074

NASA
CP
2074
c.1

LOAN COPY: R
AFWL TECHNICAL
KIRTLAND AFB

0067242



Carbon Fiber Risk Analysis

An industry/government briefing
held at Langley Research Center
Hampton, Virginia
October 31 - November 1, 1978

NASA





NASA Conference Publication 2074

Carbon Fiber Risk Analysis

An industry/government briefing
held at Langley Research Center
Hampton, Virginia
October 31 - November 1, 1978

NASA

National Aeronautics
and Space Administration

**Scientific and Technical
Information Office**

1979

PREFACE

Because graphite and carbon fiber composites provide high strength and stiffness relative to weight, they have the potential for widespread future use in the U.S. and abroad. The fibers, however, are electrically conductive and lightweight. Should the fibers be released from the composite such as might occur in an aircraft crash/fire, wherein the binding resin or matrix is burned away, the fibers can become airborne and dispersed over large areas. The settlement of the fibers on electrical and electronic equipment may cause short circuits or malfunctions resulting in costly shutdowns, fires, shock, etc.

This publication is a compilation of the presentations and the pertinent questions and answers arising during a briefing for industry and government held by NASA Langley Research Center on October 31 and November 1, 1978. The scope and status of the work being done under the direction of NASA to assess the risks to the nation associated with the accidental release of carbon/graphite fibers from civil aircraft were presented at this briefing.

This publication was prepared from tape transcriptions of the conference presentations with only minimal editing. Thus, there is the possibility of a degree of incompleteness. Since material presented in this report was taken from a variety of sources, various units of measure are used. A conversion table is included after the Contents. Use of trade names or names of manufacturers in this report does not constitute an official endorsement of such products or manufacturers, either expressed or implied, by NASA.

Robert J. Huston
Conference Chairman

Page intentionally left blank

INTRODUCTION

Graphite or carbon fibers in an epoxy matrix provide a composite material having high strength and stiffness relative to weight. Because low weight is such an important consideration in aircraft structures, NASA has undertaken a variety of activities intended to resolve problems involved in applying these composite materials to aircraft structures. NASA activities include laboratory studies as well as major projects to give flight experience with composites in secondary and primary structures on commercial aircraft. However, because of their low density, small diameter, and high electrical conductivity, graphite fibers raise issues beyond those normally considered in structural design.

Since graphite fibers are electrical conductors, they can cause short circuits, equipment malfunctions, or possible fires if they get into electrical or electronic equipment. Furthermore, because of their low density and small diameter, graphite fibers carried aloft in a fire plume or otherwise can remain airborne for considerable time, and hence can be transported from the scene of an accident to the site of electrical or electronic equipment^{1,2}. NASA has underway a project to quantify the risk associated with this electrical hazard, and has also initiated exploratory investigations of alternate materials which can reduce electrical hazards and yet retain or enhance currently available graphite fiber composite properties.

On October 31 and November 1, 1978, NASA Langley Research Center held a briefing to inform both industry and government of the scope and status of the work being done to assess the risks associated with the release of carbon fibers from accidents of civil aircraft. The briefing, which is documented herein, presented the approach being taken to perform the risk assessment and the analytical, test, and economic study work being performed to provide a data base for the risk assessment. Preliminary estimates were presented of the risk associated with civil aircraft operations at a single major hub airport and nationwide.

The briefing provided an interim report on the status of the NASA-directed risk assessment work. Completion and final reporting of the NASA work is scheduled for late fall of 1979.

¹A Report of Observed Effects on Electrical Systems of Airborne Carbon/Graphite Fibers. NASA TM 78652, 1978

²Intergovernmental Committee, Compilers: Carbon Fiber Study. NASA TM 78718, 1978

Page intentionally left blank

CONTENTS

PREFACE	iii
INTRODUCTION	v
UNIT CONVERSION FACTORS	ix
1. WELCOME AND OVERVIEW R. R. Heldenfels	1
2. THE NATIONAL CARBON FIBER PROGRAM Leonard Harris	7
3. RISK ANALYSIS APPROACH Robert J. Huston	15
4. CARBON FIBERS AND COMPOSITES Richard A. Pride	29
5. SOURCE OF RELEASED CARBON FIBERS Vernon L. Bell	41
6. DISSEMINATION, REDISSEMINATION AND FIBER LIFE Wolf Elber	73
7. TRANSFER FUNCTIONS Israel Taback	99
8. VULNERABILITY Israel Taback	109
9. END-TO-END TESTING Richard A. Pride	125
10. SURVEYS FOR SENSITIVITY TO FIBERS AND POTENTIAL IMPACTS FROM FIBER INDUCED FAILURES A. J. Butterfield	141
11. RISK METHODOLOGY OVERVIEW Karen R. Credeur	159
12. AN ASSESSMENT OF LOCAL RISK Leon Pocinki	173
13. AN ASSESSMENT OF NATIONAL RISK Ashok Kalelkar and Joseph Fiksel	199

14. CONCLUSIONS	235
Robert J. Huston	
15. PANEL RESPONSE TO QUESTIONS	239

UNIT CONVERSION FACTORS

<u>To convert from</u>	<u>to</u>	<u>multiply by</u>
inch	meter	2.540×10^{-2}
foot	meter	3.048×10^{-1}
mile	meter	1.609×10^3
pound	kilogram	4.536×10^{-1}
gallon	cubic meter	3.785×10^{-3}
liter	cubic meter	1.000×10^{-3}
feet per minute	meters per second	5.080×10^{-3}
miles per hour	meters per second	4.470×10^{-1}
miles per hour	kilometers per hour	1.609
pressure (psi)	pascal	6.895×10^3
temperature $^{\circ}\text{F}$	temperature K	$T_K = (T_F + 459.67)/1.8$
horsepower	watt	7.457×10^2
Btu	joule	1.055×10^3

WELCOME AND OVERVIEW

1

R. R. Heldenfels
Director for Structures
NASA Langley Research Center

Welcome to the Langley Research Center. We are pleased that you came to this briefing on the risks associated with the accidental release of carbon fibers from civil aircraft. This is the first formal report on our risk assessment activities. Hopefully the information that you will receive in the next day and a half will be useful in planning your future programs for the application of carbon-fiber composites. We will appreciate hearing your comments and suggestions for improving our program. Our basic goal is to obtain a reliable estimate of the public risk that may result from using carbon fibers on current and future civil aircraft in the United States.

As you are aware, carbon-based fibers, often referred to interchangeably as graphite or carbon fibers, have high strength and stiffness that make them very attractive as the fibrous component of a composite material. Such composites are being used in an increasing number of applications because of their performance and cost benefits. These current and projected applications include sporting goods, automobiles, aircraft, and spacecraft in both the civil and military sectors. NASA, in particular, has conducted and sponsored extensive research and development to support the application of composite materials in civil aircraft. This NASA activity has emphasized carbon-fiber composites and it has been oriented primarily toward commercial transport applications. Significant use of carbon-fiber composites is planned for most of the new commercial transports now in the design stage.

However, because of their high electrical conductivity, free carbon fibers that get into electrical equipment and settle on or across electrical contacts or circuits can cause equipment malfunctions or damage. Plants that manufacture or process carbon fibers have experienced such problems but have solved them easily by protecting or modifying the equipment involved. As long as carbon fibers are part of a composite material (imbedded in a matrix), they pose no known hazard. They can become an electrical hazard if free fibers are released from the composite in an accident.

Figure 1 is a photograph of some carbon fibers that were released from a composite laminate placed in a fire. Note particularly the length scale that is 1-mm long (0.04 in.) and compare it with the diameter of the single fibers (0.008 mm).

These fibers are so small that they are very hard to see with the naked eye. They are not easy to detect and people could be unaware of their presence around electrical equipment.

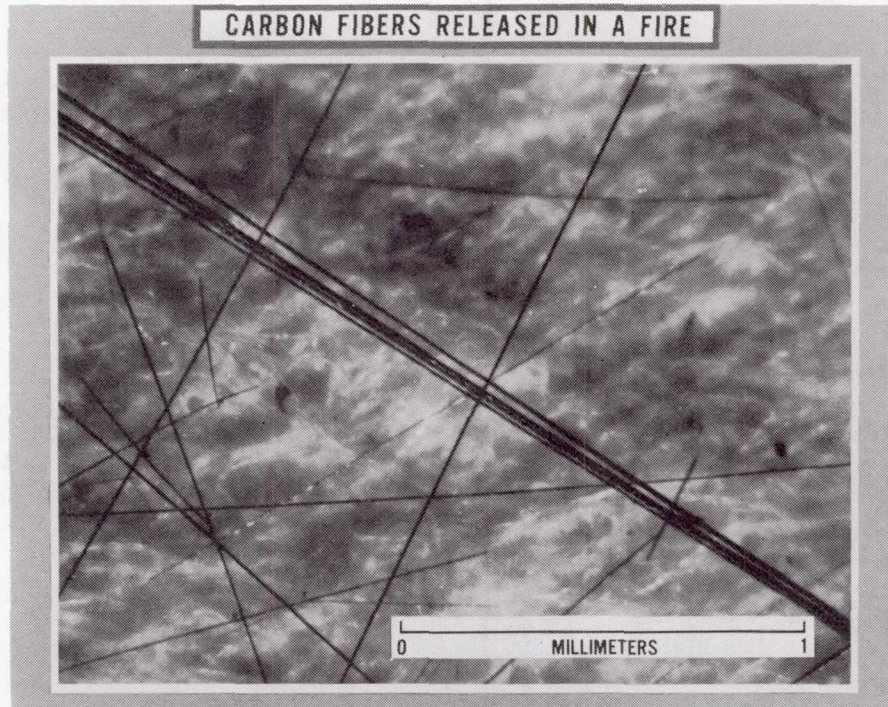

Figure 1

Figure 2 is a photograph of an electric arc that was created by placing a carbon fiber across high voltage electrodes. It illustrates the kind of result obtained when electrical equipment is tested for vulnerability to carbon fibers. A subsequent talk will discuss equipment vulnerability in detail.

A logical question is how much equipment damage has actually resulted from the accidental release of carbon fibers? The answer is not much! The problem was highlighted initially by significant electrical power failures that resulted when a batch of carbon fibers was placed in an incinerator and individual fibers were subsequently dispersed over a large area. A few military aircraft crash fires have released carbon fibers, but no damage to electrical equipment has been specifically traced to these accidents.

However, the risk of accidental release will increase with the expected increase in carbon fiber use in both civil aircraft and other applications. Consequently, a federal study of this potential problem was conducted last year. The next talk will

FIBER INITIATED ARC

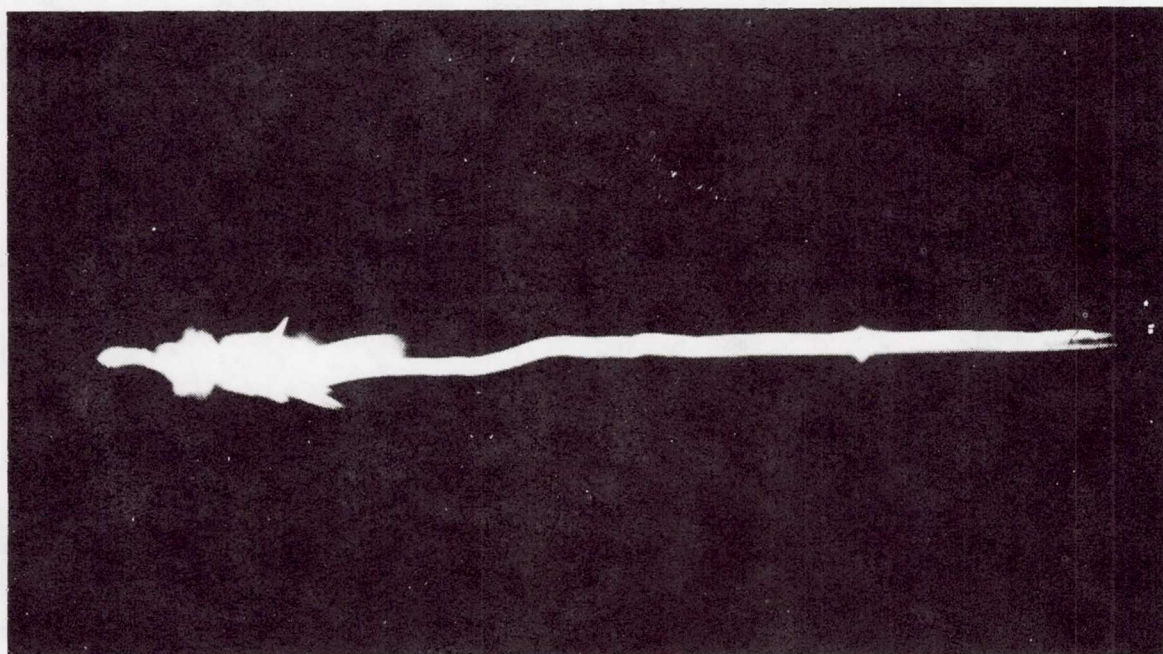

Figure 2

describe the background and results of that study and the federal action plan that it produced. That action plan assigned to NASA the responsibility for determining the risk associated with accidental release of carbon fibers from civil aircraft. NASA Headquarters subsequently assigned that task to the Langley Research Center.

This briefing is a progress report on the risk assessment activities conducted here at Langley with significant support from many organizations in government, industry, and universities. A number of laboratories in the Department of Defense have made major contributions to our program. Thus far, we have concentrated on commercial transport aircraft as a source of released fibers, but before we finish we will investigate the risk from composite structures on all types of civil aircraft.

The question we are trying to answer and our approach is outlined on figure 3. The question is: Is the potential damage that may be created by the release of carbon fiber from an aircraft accident significant compared to the benefits that accrue from the use of composite materials in aircraft construction?

RISK OF CARBON FIBER RELEASE FROM CIVIL AIRCRAFT

QUESTION: IS THE POTENTIAL DAMAGE SIGNIFICANT COMPARED TO THE BENEFITS FROM CARBON FIBER USE?

APPROACH:

1. RISK ANALYSIS METHODS AND DATA.
2. RISK ASSESSMENTS OF CIVIL AIRCRAFT APPLICATION SENARIOS.
3. COMPARISON OF DAMAGE COST PROBABILITIES AND BENEFITS FROM APPLICATIONS.

Figure 3

Our first step is to collect and develop the risk analysis methods and the experimental data required to deal with this particular problem. Then we will conduct a risk assessment that will define the probability of various degrees of damage from current and projected applications of composite materials in civil aircraft. The status of what we have done on these two things will be reported at this meeting. This is a very complex problem. It involves the probability of occurrence of many things, such as the number and location of accidents, the amount of carbon fiber on the aircraft, how much fiber is released, how the fibers are disseminated, how far they go, what kind of equipment is in the area where the fibers are deposited, and the effect of these fibers on that equipment. Then we must estimate the cost of equipment repair and replacement. Some of these costs and probabilities are easy to define, but many involve phenomena that are relatively unexplored. There is a great lack of pertinent data. However, we are pushing ahead to collect the data required and are trying to scope the problem as soon as possible. When we have an acceptable risk assessment, we will take the third step and compare the probable losses from this phenomenon with other risks to which the public is subjected and to the benefits that accrue to society from carbon-fiber composite applications.

An important consideration in our study is the character of the carbon-fiber hazard compared to other potential hazards of current public concern, such as those that arise from possible failure of nuclear power plants or those that are associated with accidents in the handling of liquified natural gas. Both the nuclear and LNG hazards have the potential for causing substantial loss of life as well as damage to property. Their risk assessments are dominated, however, by loss of life. On the other hand, the carbon-fiber hazard is primarily a producer of potential property damage. Any loss of life that might result from release of carbon fibers will be a secondary consequence of an equipment failure. The carbon-fiber problem, therefore, should be of much less public concern than many other hazards to which people are often exposed because the fatalities will be few and most of the damage can be repaired easily.

Another consideration that reduces the near-term concern is the relatively small amount of carbon fiber currently in use on civil aircraft. No civil aircraft that incorporates carbon-fiber composite structural components has been involved in an accident. A few military aircraft with carbon-fiber composite structures have crashed and burned, but no carbon-fiber related damage has been observed around those accident sites. On the other hand, a crash fire of a military aircraft produced a variety of charred materials that caused electrical failures near the fire. That aircraft had no carbon-fiber composites on board. Thus, to date we have meager experience with the consequences of carbon fibers released from actual accidents. In addition, carbon fibers are not the only potential source of electrical equipment failures in the vicinity of an aircraft crash and fire.

We will be giving you much detailed information on our state of knowledge of the carbon-fiber hazard, the progress we have made, and the problems we have encountered with risk assessment. But first I will make a few observations based on our experience.

1. The amount of data needed and the complexity of the problem continue to increase as we learn more about it, but we are making progress.

2. The equipment we have tested for vulnerability appears to be less vulnerable than anticipated. In many cases we found that repair can be achieved by use of a vacuum cleaner.

3. Techniques are available to protect electrical equipment from the carbon-fiber hazard if the manufacturers and owners of this equipment are sufficiently motivated to do so.

4. The most probable cost of the damage produced by accidental release has been decreasing as we learn more about the problem and refine our studies. Our interim results, to be presented in a later talk, suggest that the carbon-fiber hazard has the potential of adding only a very small increment to the cost usually associated with aircraft accidents.

5. Estimated future annual costs of property damage that could result from release of carbon fibers from civil aircraft accidents appear to be small compared to the property damage that regularly occurs from a variety of natural and man-made causes in the United States.

We will present our plans and results in detail in this briefing so that you can judge for yourself how optimistic the outlook may be. But please tell us if you see places where we have been unduly optimistic or pessimistic.

In conclusion, we have undertaken the difficult and complex task of assessing the risks associated with the use of carbon-fiber composites on civil aircraft. Our progress has been somewhat slow, but we have made a commitment to obtain at least an interim answer within the coming year. We will tell you what we have learned and where we plan to go. We solicit your comments, suggestions, and advice on how we can improve our program. We appreciate your attendance, hope you find the information we present useful, and hope that this briefing was a productive use of your time.

Leonard Harris
NASA Headquarters

I hope my comments will give you a perspective as to how some of us at NASA Headquarters view the graphite phenomenon, not just in terms of the aerospace community but of the total community involved in the use of advanced carbon fiber composites. As Dick Heldenfels has already pointed out, there has been a rapid growth in the use of carbon fiber composites. The growth is quite outstanding. It was only about 15 to 20 years ago that the Air Force, and subsequently NASA, began spending considerable effort in developing the basic materials from which this industry has grown. In the perspective of just the civil aircraft market, which figure 1 addresses, we are talking about an application today of tens of thousands of pounds of graphite annually and one which projects in the 1990's to a million or more pounds per year of graphite fiber usage. This is an exceptional growth for a new material.

**ESTIMATED USE OF GRAPHITE FIBER FOR
NON-MILITARY AEROSPACE APPLICATIONS**

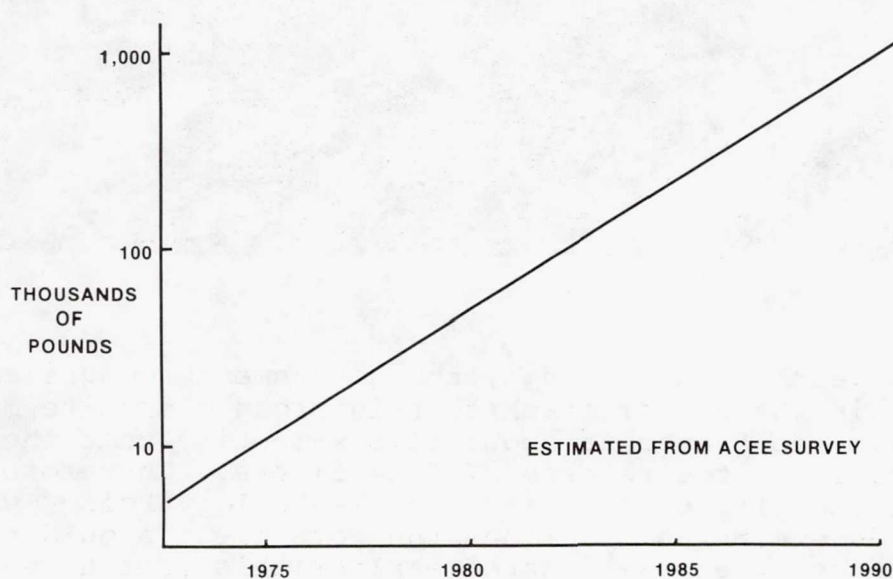

Figure 1

But what accompanies such a rapid growth is the likelihood of surprises, one of the likely perspectives of the rapid growth of any new material. There have been surprises other than the graphite phenomenon during the rapid development

of advanced composites.

Looking further, there is a perspective that requires a certain set of sequences to exist if the carbon fibers that exist in a composite are to escape as free fibers. Figure 2 is a photo from a crash of a U.S. Navy fighter. The fibers are not carbon in figure 2, but the photograph illustrates the potential problem in a crash fire situation in which, under certain conditions, the fibers could become freed from the resin matrix. It is this issue with which this meeting is dealing - the quantification of the risk and associated costs.

FIBER RELEASE IN AIRCRAFT CRASH



Figure 2

About a year and a half ago, the government recognized the rapid growth in the use of graphite reinforced composite materials and also recognized at about this same time that there was a potential for the release of free fibers. Therefore, the Director for the Office of Science and Technology Policy was directed to determine what actions the government should take. As a consequence, there was issued earlier this year a report from the Department of Commerce which described the phenomenon and a NASA technology publication which described some of its technical details.

The government study resulted in an action plan for the civil sector which is outlined in figure 3. The agencies

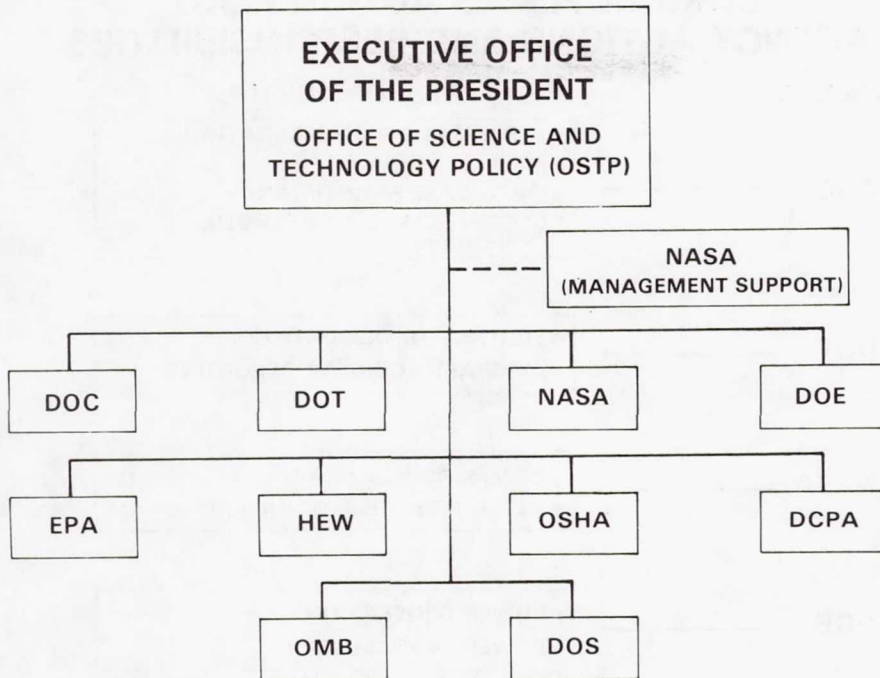

Figure 3

involved, shown in the figure, are those which have specific assignments with respect to the civil sector of the user community. Shown on the top line, the Department of Commerce relates to general civil use, the Department of Transportation to potential automotive or truck applications, NASA to civil aircraft, and the Department of Energy to the production and distribution of power. The second line on the chart represents the agencies that are involved in terms of health and the environment, EPA, HEW, OSHA and the Defense Civil Preparedness Agency. The latter agency has a role in information distribution should a crash occur with a civil aircraft containing carbon fiber. The OMB is involved in budgetary issues and the Department of State in issues related to the foreign market.

Figures 4 and 5 show more explicitly what the assignments are. As shown in figure 4, the Department of Commerce has an overall responsibility for the distribution of data to the total community. They issued the initial press release on the phenomenon earlier this year. The Department of Transportation has obvious interest with respect to the use of graphite in automotive applications and that potential is very great. Our interest at NASA is very straight-forward - we are supporting the aerospace applications and the overall technology associated with what one might do to modify the

CARBON FIBERS ACTION PLAN AGENCY ACTIONS AND RESPONSIBILITIES

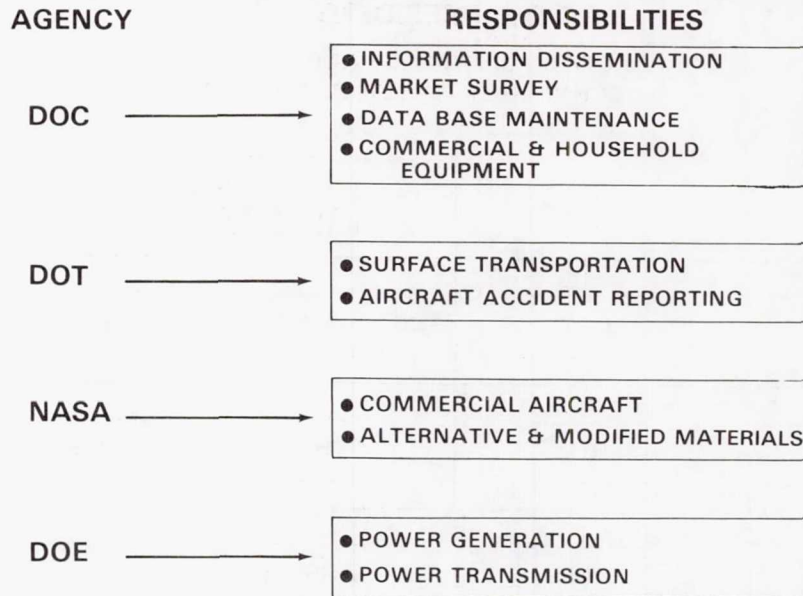

Figure 4

CARBON FIBERS ACTION PLAN AGENCY ACTIONS AND RESPONSIBILITIES

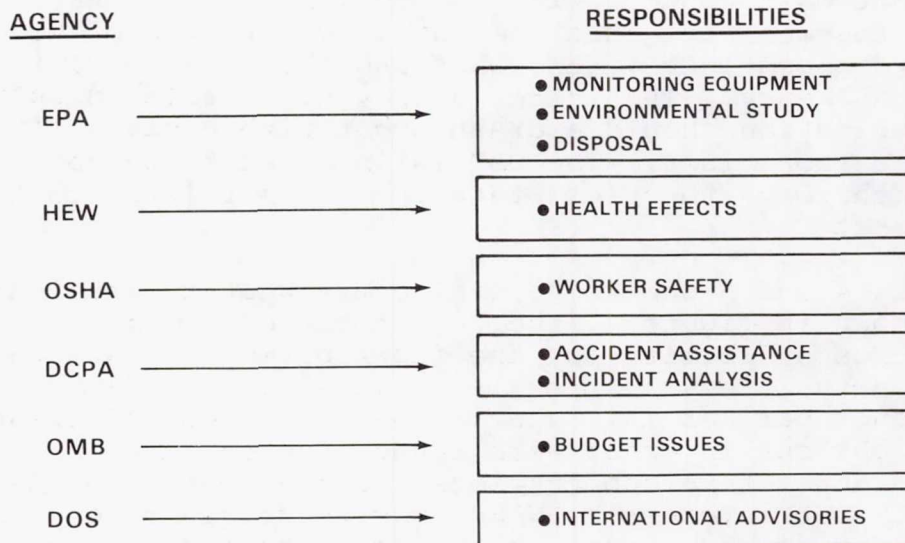

Figure 5

material to alleviate the problem. The Department of Energy is concerned with possible effects of fiber release on power generation and transmission systems. Figure 5 shows the responsibilities of the other involved agencies.

The NASA responsibilities are further defined in figure 6. The first is the subject of this meeting - to quantify the risk associated with the use of graphite bearing composites, in particular with respect to their use in aircraft. In addition, we have an explicit responsibility for research on materials modification which would eliminate the potential for the release of free graphite fiber from composites. NASA is also responsible for management support of the national program.

CARBON FIBER ACTION PLAN NASA RESPONSIBILITIES

- **RISK ASSESSMENT/AIRCRAFT PROTECTION**
 - LANGLEY RESEARCH CENTER

- **MATERIALS MODIFICATION AND ALTERNATE MATERIALS**
 - AMES RESEARCH CENTER
 - JET PROPULSION LABORATORY
 - LANGLEY RESEARCH CENTER
 - LEWIS RESEARCH CENTER
 - MARSHALL SPACE FLIGHT CENTER

- **OSTP MANAGEMENT SUPPORT**
 - NASA HEADQUARTERS

Figure 6

Let me amplify for a moment that portion of the study which we will not discuss further in this meeting. That is the material modification program which is being conducted jointly by the five NASA Centers indicated on figure 6 and amplified on figure 7. There are two portions to the program. The first has to do with what one might do for relatively simple changes to existing materials systems so that the risk would be significantly reduced. These tasks are predominantly being performed at Ames, Lewis and Langley Research Centers in an in-house program supplemented with industrial

MATERIALS MODIFICATION PROGRAM

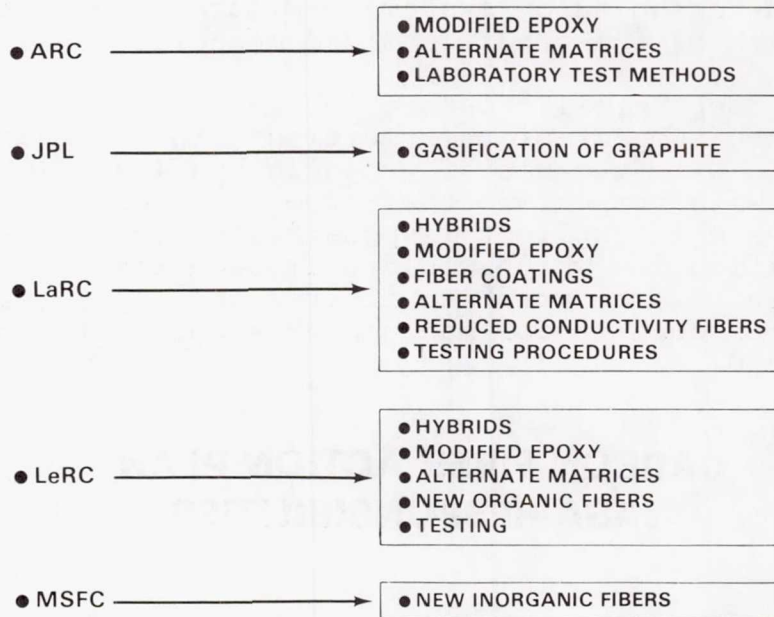

Figure 7

and university contracts. In addition, we have a program which involves all five Centers and is searching for longer term solutions which might use different materials. These latter approaches inherently have a longer lead time and might provide new materials with different structural performance, as well as alleviation of free graphite fibers.

In perspective then, the NASA roles are to quantify the risk with respect to the commercial aircraft use of composites and at the same time to find methods of modifying the materials so that the problem is not inherent with their use. But there is a further perspective, since by and large the development of composites and their early industrial utilization were fostered by government participation, particularly by the DOD and NASA. Our obligation transcends the limited view of aerospace. A way of envisioning this is shown in figure 8, which is a forecast of the potential market for advanced composite materials. When first used, aerospace, particularly DOD, applications clearly predominated. In contrast, sporting goods clearly make up the larger part of the current market. In the future, there will be an interim period in which aircraft applications may again become predominant, but in the long run, non-aerospace applications will vastly exceed their use in aerospace. So we need to leave a legacy of knowledge that assures the user that he

PREDICTED USE OF CARBON FIBERS

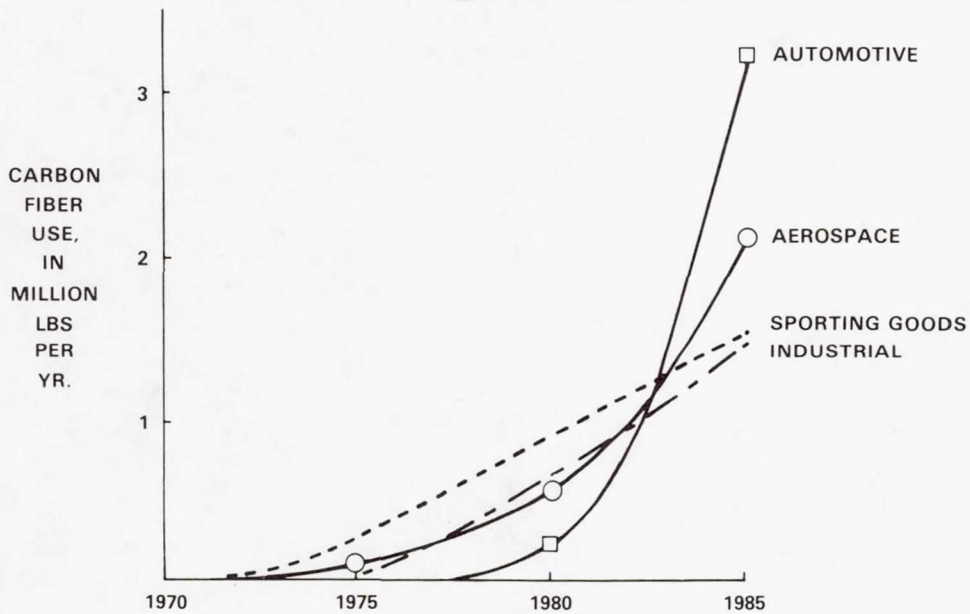

Figure 8

can use the material, that it has a benefit that is substantial, and that the risk is low in utilization of the material. In perspective, this legacy is what this meeting is about.

Page intentionally left blank

RISK ANALYSIS APPROACH

Robert J. Huston

Manager, Graphite Fibers Risk Analysis Program Office
NASA Langley Research Center

I would like to introduce the presentation of this activity at Langley by presenting an outline which you can use as a road map of the work that you are going to hear about for the rest of the day. Our program objective is identified in figure 1. We have said it several times already, but basically it is to quantify the national risks associated with accidental release of carbon fibers (CF) from civil aircraft having composite structures. Because of the sparsity of CF on current civil aircraft, we are looking ahead 15 years. As a part of determining the national risk, we will be looking for potential equipment damage on civil aircraft and, therefore, we will assess the need, if any, to protect civil aircraft from accidentally released carbon fiber.

CARBON FIBER HAZARD RISK ASSESSMENT

PROGRAM OBJECTIVES

- QUANTIFY RISK ASSOCIATED WITH ACCIDENTAL RELEASE OF CARBON FIBERS FROM
CIVIL AIRCRAFT HAVING COMPOSITE STRUCTURES
- ASSESS THE NEED FOR PROTECTION OF CIVIL AIRCRAFT TO ACCIDENTALLY RELEASED
CARBON FIBER

Figure 1

What requirements do we have on a risk assessment? First, as shown in figure 2, we must develop an accident scenario and associated probabilities. This involves integrating both known data and judgements from experts in a logical

framework. We must explicitly state the assumptions and the source of the data so that we can assess the conservatism of the data inputs and of the judgements. Second, we must estimate public risk in a very systematic manner. Once an estimate is made, we can then determine the significance of any assumptions by sensitivity analysis, and we can quantify the uncertainty in the risks through evaluation of our assumptions, data, inaccuracies in the data, and the technical judgements that have gone into the analysis. This systematic framework also allows us the opportunity of evaluating risk reduction strategies. We have already mentioned one such strategy, the alternate materials program, which is a strategy to develop alternates to current graphite epoxy composites where the mechanism of release of graphite fibers from the composite is modified or the airborne characteristics of the fibers are changed in a favorable way. Other strategies such as protection of a substantial portion of the electrical equipment in the U.S. might be offered (as a ridiculous option) but some acceptable option could be developed. The final requirement on our risk assessment is that we perform the analysis in such a manner that we can make comparisons of the benefit of carbon fiber with the risk and that we can assess the risk against other risks of which we are familiar in other areas.

RISK ANALYSIS

DEVELOPS ACCIDENT SCENARIOS AND ASSOCIATED PROBABILITIES

INTEGRATES KNOWN DATA AND JUDGEMENT FROM EXPERTS IN A LOGICAL
FRAMEWORK

EXPLICITLY STATES ASSUMPTIONS

ESTIMATES PUBLIC RISK IN A SYSTEMATIC MANNER

DETERMINES SIGNIFICANCE OF ASSUMPTIONS BY SENSITIVITY ANALYSIS

QUANTIFIES UNCERTAINTY

PERMITS EVALUATION OF RISK REDUCTION STRATEGIES

PERMITS COMPARISON WITH BENEFITS AND OTHER RISKS

Figure 2

Let us look now at the scenario that we have adopted as of interest for the accidental release of carbon fiber from

civil aircraft. Figure 3 illustrates the scenario that we see is important for the air transport aircraft. We are hypothesizing accidents of civil aircraft, usually near major airports, where the efflux from the burn of an aircraft containing composite has an opportunity to be distributed downwind and to contaminate the airport terminal facilities and air traffic control and ground control approach systems. This efflux has an opportunity of being carried into shopping centers, banks, local businesses, and into the homes of private individuals, where household appliances could be affected by the released graphite fibers. We have to be concerned with public service areas, such as telephone exchanges and hospitals, as well as manufacturing and transportation facilities. Of course, one item ties all of these together. This network is the power distribution system of the various utility systems.

RISK ANALYSIS SCENARIOS

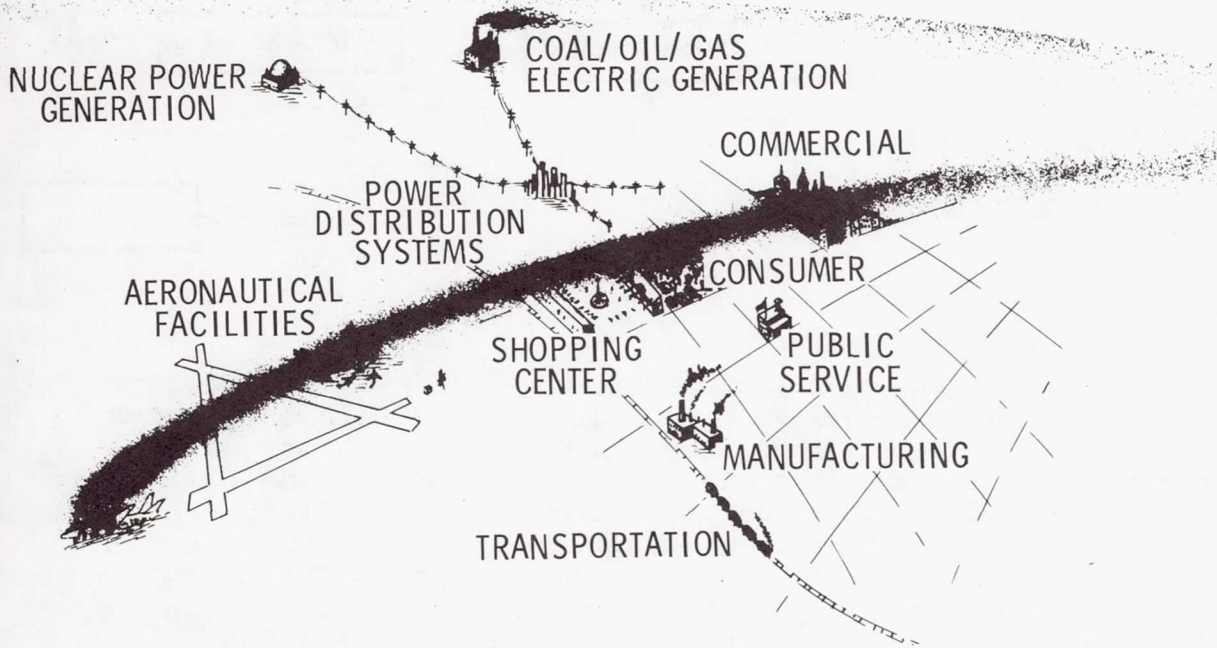

Figure 3

Another dimension of the risk analysis is illustrated by the risk analysis flow chart shown in figure 4. Six elements are associated with the physical phenomena of the accidental release. I will go through this in a little more detail, step by step, and since this conference is organized along the lines of this chart, I will only mention that basically I am referring to the source of carbon fiber, the potential dissemination of carbon fiber, the life of the released fiber (which may result in a potential redissemiation that might cause a problem at a later time), the transfer of

CF from the exterior of enclosures to the interior, and the vulnerability of equipment associated with the various areas of importance identified in the risk analysis scenario. In the final step, we must relate the demographic data with the density of equipment in homes and businesses to determine cost impacts.

RISK ANALYSIS FLOW

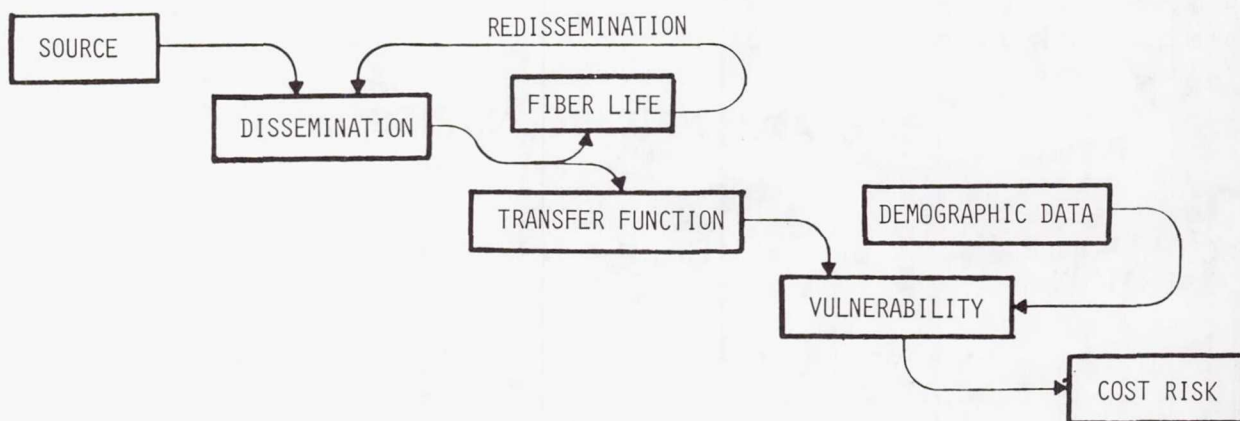

Figure 4

Looking at the element of source, figure 5, this first area covers the release of carbon fibers. Within the context of a risk assessment, we must determine the quantity of released fibers and their character. In order to determine the quantity of released carbon fibers, we must first project the use of carbon composites in the future. You have seen some projections earlier. We must then estimate the most likely locations and magnitude of accidents as well as the type of accident. It is important, in determining the release of graphite fiber, to know whether the accident was a crash burn, or a burn explode, or a total demolition at contact. We have National Transportation Safety Board (NTSB) data on accidents, but we are currently investigating, in depth, the details of all U.S. built jet transport accidents on which to base a better analysis. Fiber release is influenced by a number of factors: fire size and temperatures, the length of the fire, the nature and the character of composite material, and where it is used in the aircraft. Finally, the character of the released fibers must be determined. The character of the fibers includes the mass of fiber released, the form (single fibers,

clumps, clusters, and strips), and the length and diameters of single fibers.

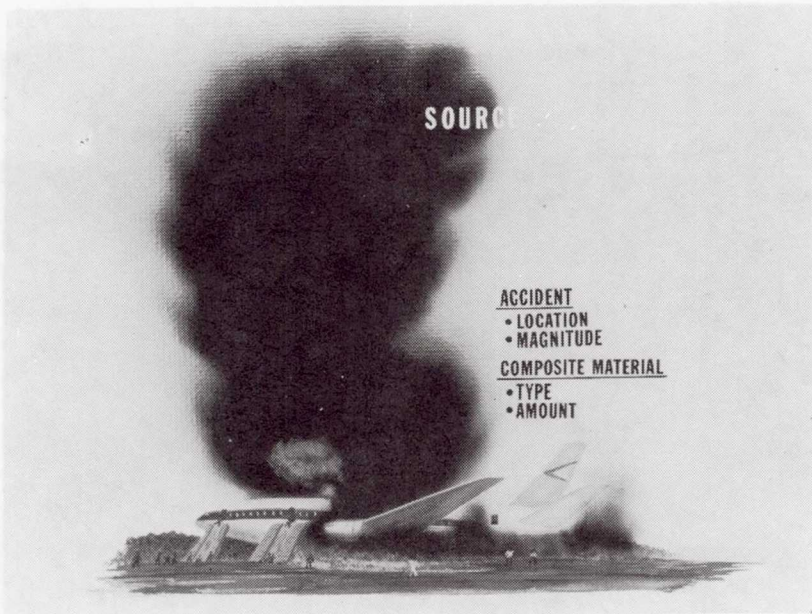

Figure 5

Given that fibers are released as single fibers or in other forms, the fibers will be carried off by the fire plume, as shown in figure 6. They will be carried up and away from the location of the fire or, if by an explosion, projected away from the source of the fire and then dispersed downwind from the accident scene. This dispersion can be characterized in several ways; one way is by looking at footprints of concentration of fibers, or by exposure. Some of the key elements involved in the dispersion estimates include the fire plume development, which depends upon the weather, the amount of fuel burned, and the rate of burn. The items that affect the dispersion of the cloud of fibers downwind from the fully developed fire plume include the weather and the fall rate or settling rate of the released fiber.

The footprints are presented in terms of exposure, as defined in figure 7, since exposure has been found to be the key parameter in the probability of failure of electrical equipment.

One element that must be included in our final risk assessment and has not been included to date is the long term effects of released fibers, which conceivably could be redisseminated by winds or through mechanical agitation. Let me say simply that in addition to the potential for

DISSEMINATION

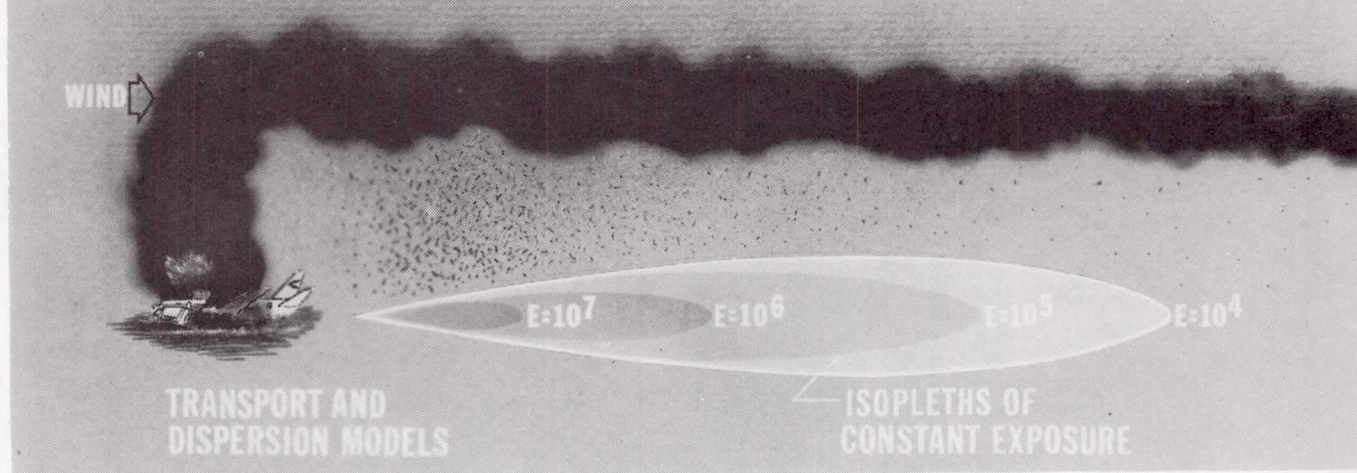

Figure 6

DEFINITIONS

C	CONCENTRATION	$\frac{\text{NUMBER OF FIBERS}}{\text{METER}^3}$
E	EXPOSURE	$\frac{\text{NUMBER OF FIBERS}}{\text{METER}^3} \times \text{SECONDS}$
		$E = \int C dt$
\bar{E}	CRITICAL (MEAN) EXPOSURE	PROBABILITY OF DAMAGE = $1 - e^{-E/\bar{E}}$
T. F.		TRANSFER FUNCTION, RATIO OF QUANTITIES ACROSS AN INTERFACE, FOR EXAMPLE: $E_{\text{INSIDE}}/E_{\text{OUTSIDE}}$

Figure 7

redissemination, we would expect that the character of released fiber might change with time. Figure 8 shows an hypothesis about the change in character of the length spectrum with time. A later speaker will discuss this in more detail.

"FIBER LIFE" & REDISSEMINATION

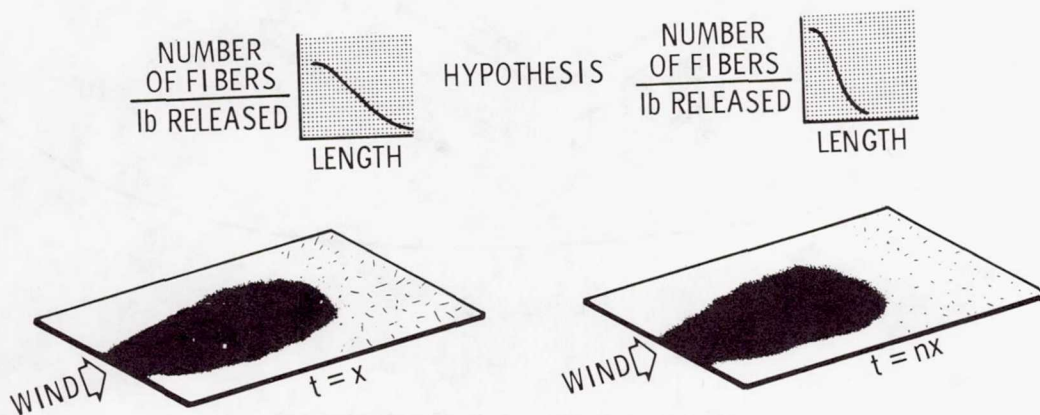

Figure 8

Eventually, the released carbon fiber will reach homes, businesses, and factories, and we must estimate what interior fiber concentration or exposure will result. Figure 9 illustrates the expected effect, though a number of factors influence the actual values of what we call transfer function. Some of the factors that affect the transfer function include the use or nonuse of air-conditioning, the condition of windows (opened or closed) in buildings, natural ventilation, the fall rate of fibers, and generally the nature of air circulation and what kind of filtration, if any, is used in buildings.

Once fiber concentrations are carried to electrical equipment, the electrical conductivity of the fiber can result in a hazard to susceptible equipment. The probability of failure for a couple of assumed examples is illustrated in figure 10 and has been experimentally determined to follow the exponential relationship cited on the definition chart (figure 7).

TRANSFER FUNCTION

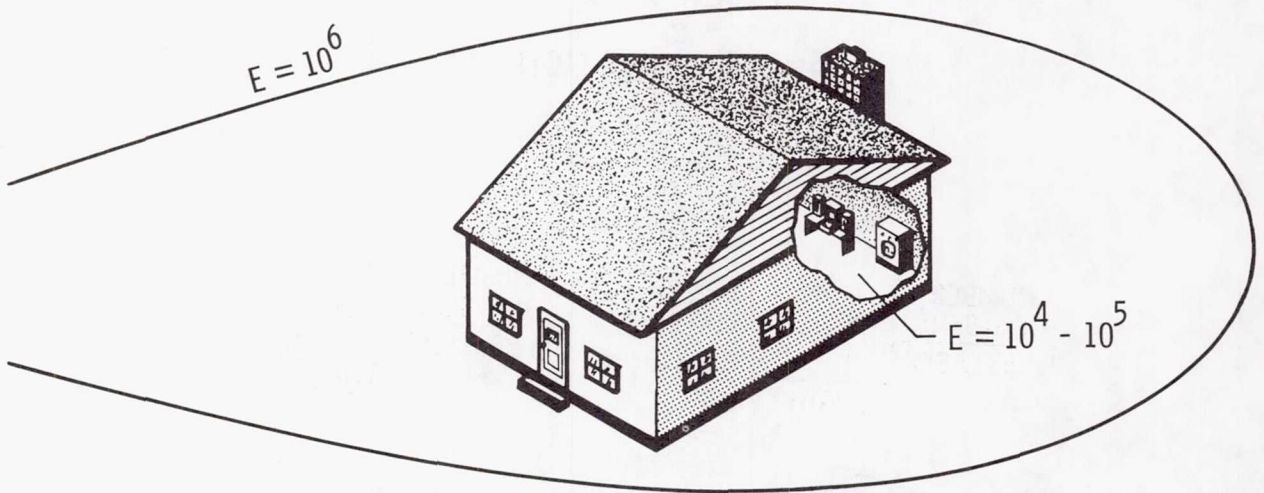

Figure 9

VULNERABILITY OF EQUIPMENT ASSUMED CRITICAL EXPOSURE LEVELS (\bar{E})

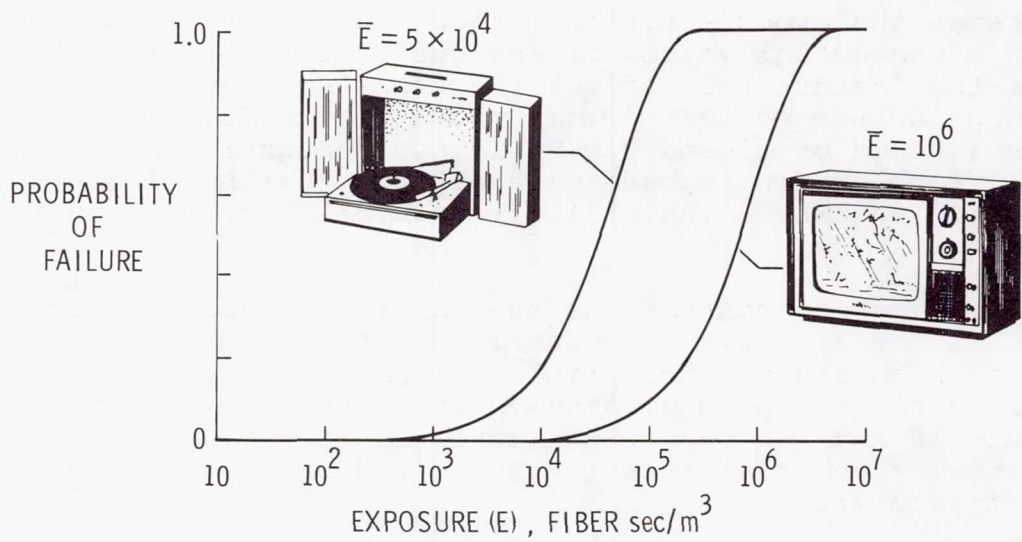

Figure 10

For the risk assessment, we must categorize susceptible equipment into classes and categories appropriate for investigation in risk models. This means that we must determine the susceptibility and vulnerability of a wide range of equipment in the very diverse areas covering household, business, and industrial electrical equipment. Let me point out that the values shown here are simply selected for illustration and the subsequent speaker will show some data on a range of civilian equipment that might be involved in a carbon fiber problem. Let me also point out that this is plotted in a little different form from that you sometimes see; that is, the probability of failure is represented on a log plot, which gives you an S-shaped curve in contrast to the exponential form on a linear plot that most researchers in this area utilize.

Finally, we must combine the physical models with our demographic model in such a way as to obtain a suitable measure of risk. One such measure is the risk profile illustrated in figure 11 which gives the annual probability of exceeding a given dollar damage as a function of the dollar damage. Since you are going to see a few of these over the next couple of days, I thought it might be appropriate to give you a simple example. Basically, at a point on the abscissa representing, for example, a million dollars, or whatever number you want to choose, the ordinate gives the probability of exceeding the million dollars in a given year. This representation might be unfamiliar to some who have not studied risk analysis in the past but it has been used as a typical measure in analyses that have been done in the areas of nuclear power and liquid natural gas transportation.

Let me now outline our approach to the risk analysis program. (See figure 12.) A central portion of our effort is to develop an adequate data base for a credible analysis. In many areas, before we can actually generate data, we must perform what we call pathfinder studies to determine what data should be obtained. These pathfinder studies, for example, involve looking at specific types of electrical equipment, determining in what manner they might be exposed to carbon fibers, and determining what kind of test is needed. We have the capability to assess the vulnerability of electrical equipment by exposing the equipment in a fiber chamber but in some cases we have found that other methods can be used. They will be discussed in a later presentation. When you first study a new area, you must quantify the new area. We have found that it is necessary to go out and physically survey hospitals, telephone exchanges, and factories in order to determine in what area we need to make measurements. The data and pathfinder studies are being used in our analysis

RISK ANALYSIS SCENARIOS

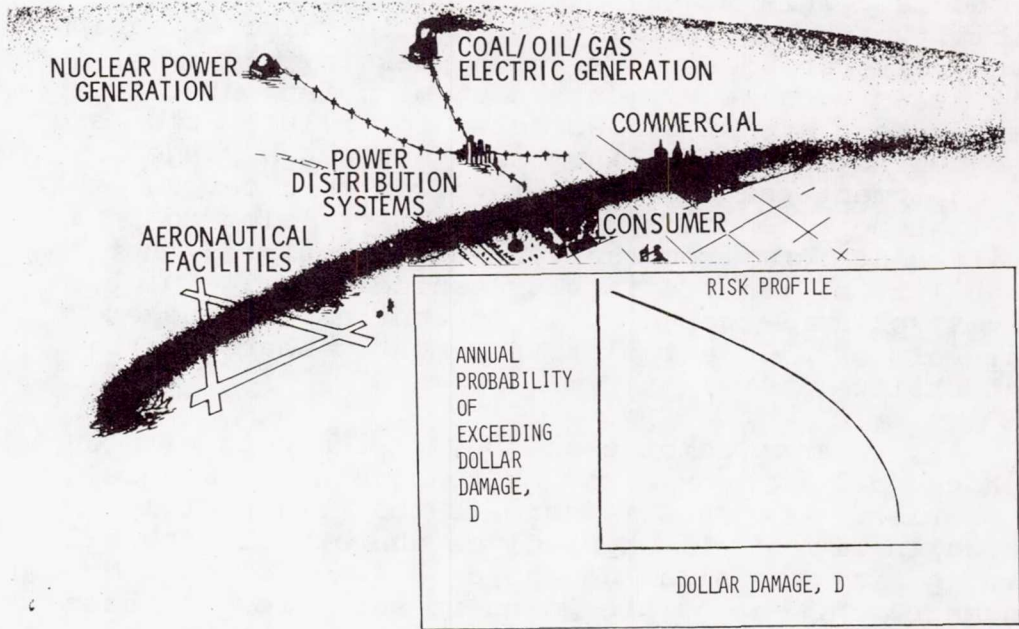

Figure 11

PROGRAM OUTLINE
ASSESSMENT OF RISK ASSOCIATED WITH ACCIDENTAL RELEASE
OF CARBON FIBERS FROM CIVIL AIRCRAFT

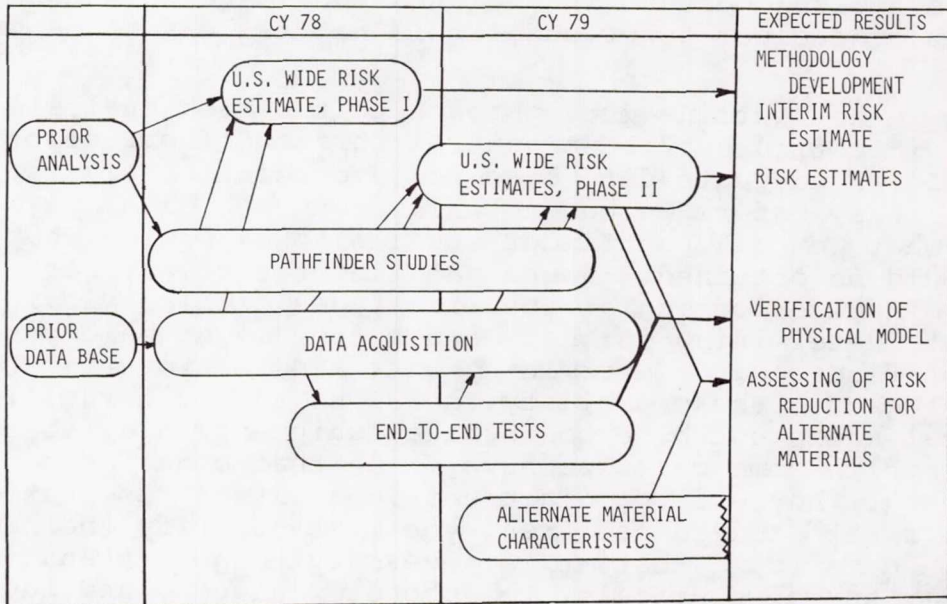

Figure 12

effort to determine the risk to the United States as a whole. Our first phase analysis effort has primarily been one to develop an adequate methodology in which we have confidence, and to make an interim risk estimate. This activity of our risk analysis has resulted in two studies that you will hear reported on tomorrow. We anticipate continuing these first phase studies through most of the rest of the calendar year. Our second phase efforts will include evaluating studies that we have currently underway and data that are expected to be generated in the near future. Our plans in each area will be covered by subsequent speakers. We will also be using data being developed by other government agencies, such as the studies of the Department of Energy in the power distribution area. Finally we anticipate performing some tests to allow us an opportunity for verification of the physical model used in the risk analysis. We are, at this time, in the initial development of what could be described as a contained end-to-end test which will be discussed by the last speaker of the day. We are also assessing the need for a full scale outdoor end-to-end test. One final item, our program allows for us to evaluate the material characteristics that are coming out of the alternate materials programs that Dr. Harris described in the second presentation of this conference. If necessary, we can assess the reduction in risk that might be associated with any particular alternate material.

We have a number of participants on the risk assessment program, as shown on figure 13. Without going into detail, I would like to just check off the list and try to indicate where the work is going on. The Fire Products Division of AVCO, in Massachusetts, is working with us on developing chamber test methods for fire testing materials to determine the characteristics of released graphite fibers. The Ballistic Research Laboratory (BRL), at Aberdeen, Maryland, has been working with us on vulnerability testing of equipment and on transfer function measurements. We have been quite heavily dependent upon that activity in the past for much of our data. The Bionetics Corporation, Hampton, Virginia, has been performing pathfinder studies and analysis that has led us to identify many areas in which additional data are needed. They have also identified areas where we can short cut some of the laborious paths that we have had to follow to analyze the risk. The commercial aircraft manufacturers, Boeing, Douglas, and Lockheed, have been assisting us by supplying information on potential uses of carbon composites in the future and in details of aircraft accidents. They are studying the airplane accidents of all jet airplanes that they have built. They have detailed data on these accidents in their files and are correlating that data with NTSB accident data so that we can have a better understanding of how much of an

GRAPHITE FIBERS RISK ANALYSIS
PROGRAM PARTICIPANTS

	SOURCE
AVCO	
BALLISTIC RESEARCH LABORATORY ABERDEEN	- VULNERABILITY, TRANSFER FUNCTION
BIONETICS CORPORATION	- PATHFINDER STUDIES
BOEING } DOUGLAS } LOCKHEED }	- SOURCE, AIRCRAFT VULNERABILITY
DAHLGREN, NAVAL SURFACE WEAPONS CENTER	- SOURCE, END-TO-END TESTS
DUGWAY PROVING GROUND	- DISSEMINATION, FIBER LIFE - REDISSEMINATION
JET PROPULSION LABORATORY	- INSTRUMENTATION
A. D. LITTLE } ORI } GEORGE WASHINGTON UNIVERSITY }	- ANALYSIS
NATIONAL BUREAU OF STANDARDS	- VULNERABILITY
SCIENCE APPLICATIONS, INC.	- DISSEMINATION
TRW	- DATA ANALYSIS

Figure 13

aircraft actually burns. We need to know what the opportunity is for a wing tip or an elevator to be involved in an actual fire. In addition, as part of the risk analysis activity and as a part of assessing the need for protection to civil aircraft, they are studying the susceptibility of electrical equipment in their current and future air transport aircraft to determine how vulnerable aircraft are and what protection may be needed. In the source area, the Dahlgren Naval Surface Weapons Center in Virginia has been testing a number of material specimens, as well as aircraft components, to determine released fiber characteristics. They are also participating in our end-to-end test activity that you will hear about this afternoon. The Dugway Proving Ground in Utah has been assisting us in calculations of dissemination and in prediction of the life and redissemination of fibers. The later data have been obtained from measurements at a site where fibers were released outdoors several years ago. The Jet Propulsion Laboratory has been looking at some innovative ideas for released fiber sensing instrumentation. We have a considerable problem with instrumentation. Dick Heldenfels mentioned earlier that you can look right at fibers and not see them. When fibers are in concentrations high enough that you can see them, such as you may have in a fiber chamber, you can hardly count them, and we actually have to count the fibers to determine the number of fibers released. The techniques to date have been primarily through manual counting. We

are trying to develop some instrumentation that will allow us to do this a little faster. I should point out that Dugway Proving Ground has been instrumental in providing this type of counting. We have A. D. Little of Massachusetts, ORI of Maryland, and George Washington University assisting us in analysis. The National Bureau of Standards is assisting us in a study of household appliances. Many household appliances can be tested by a simpler method than a carbon fiber chamber. The National Bureau of Standards has been tasked in the national carbon fiber program, with responsibility for evaluating household equipment, and is assisting NASA by determining vulnerability. Science Applications Inc., of California, under contract to the Ames Research Center, is supporting our program by providing fire dynamics and plume models. Finally, TRW Inc. of California has been analyzing data for us from the large scale burn tests they performed for the Air Force at the Navy's China Lake, California, facility. I should note that we are using data generated by other programs, such as the alternate materials program. The Ames Research Center has some burn facilities at their installation and has been supplying us with data from these facilities. In addition, we will take advantage of data generated by other agency efforts in the federal program such as the Department of Energy's activity on carbon fiber effects on power system elements.

The agenda for the remaining presentations in the conference is presented in figure 14.

BRIEFING OUTLINE

SOURCE	
● CARBON FIBER AND COMPOSITE USAGE	- RICHARD PRIDE
● FIBER RELEASE MECHANISM	- DR. VERNON BELL
DISSEMINATION, FIBER LIFE, REDISSEMINATION	- DR. WOLF ELBER
TRANSFER FUNCTION, VULNERABILITY	- ISRAEL TABACK
END-TO-END TESTING	- RICHARD PRIDE
ANALYSIS	
● OVERVIEW	- DR. KAREN CREDEUR
● PATHFINDER SURVEYS	- ANSEL BUTTERFIELD
● ORI STUDY STATUS	- DR. LEON POCINKI
● A. D. LITTLE STUDY STATUS	- DR. ASHOK KALELKAR
	- DR. JOSEPH FIKSEL
CONCLUSIONS	- ROBERT HUSTON
QUESTION AND ANSWER PANEL	- SPEAKERS

Figure 14

Page intentionally left blank

CARBON FIBERS AND COMPOSITES

Richard A. Pride
 NASA Langley Research Center

With the wide diversity of technical disciplines represented at this Risk Analysis conference, it seemed appropriate to present a paper discussing the basic nature of composite materials. Carbon fiber composites and their area of current and planned application in civil aircraft will be discussed, specifically to set the framework for the papers which follow dealing with various aspects of the risk analysis. In the area of composites, there are two elements, filaments and matrices, that have to be combined to make these kinds of materials (figure 1). Glass filaments have been available for a number of years and have been a part of composite materials, getting widespread usage on the current generation of commercial transport aircraft in such things as fairings and other lightly-loaded or non-load-carrying structures to a large extent. Glass is not generally considered to be a high performance fiber in the sense of the rest of the filaments listed here; boron, graphite, and PRD-49, or Kevlar, as it is known today. Of all these fibers or filaments that are currently in use in composite materials, only the graphite is electrically conductive. Therein lies the problem. Graphite filaments have very desirable mechanical and physical properties and they are potentially cheap

COMPOSITE MATERIALS

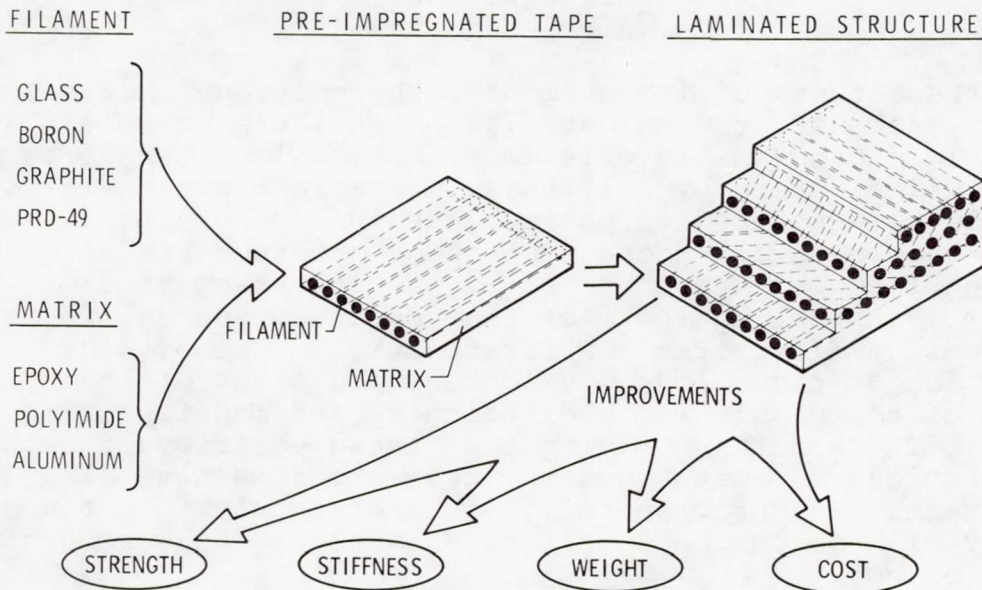

Figure 1

to produce, so they may be used in many applications where the other filaments may not.

All of the filaments must be combined with matrix materials in order to make up a structural composite material. There are a variety of matrix materials around that are being used today in different applications; however, the one that we are primarily concerned with is epoxy. The epoxy matrix is the kind of material that is used in most of the commercial applications of composite materials. Polyimides and the aluminum-alloy matrices are generally used for special applications or for high temperature applications.

The first step is to combine a matrix and a filament into what we call a preimpregnated tape. The filaments are collimated into a parallel layup, and the matrix is worked in around them and partially cured so that it will stay in place with subsequent handling. For greatest ease in handling, the tape should have a reasonable amount of tackiness to hold it in place in the laminated structure. This tape material in which the fibers are all running parallel then can be worked into a laminate--cut up and stacked into multiple plies or layers so that the different layers or plies of the material have the fibers in various orientations. After a build up of a laminated structure of this type, it is processed through a high temperature and high pressure curing cycle in an autoclave. The final product then is a composite laminated structure which has significant improvements over the existing aluminum alloy structures in terms of such things as strength and stiffness; it weighs significantly less, and it has the potential for having a final cost, after manufacturing, of less than the finished manufactured cost of aluminum hardware in the aircraft business.

Of these types of improvements, the only one that has not been adequately demonstrated to date is cost. There have been a number of technology programs in existence for the last ten or twelve years in which strength, stiffness, and weight savings have been adequately demonstrated on parts by design, manufacture, and test. The cost bubble on all these technology programs has always been significantly more than the cost of an equivalent kind of item in metal, but considering the fact that cost represents, in most of these cases, a first item - a first article type of cost, it includes a lot of technology development and a lot of learning on the part of the people who are designing and manufacturing these articles. It is not surprising that these costs would be high. The projections on cost based on these programs have always been very attractive. Unfortunately, it is difficult to get good hard data that will allow one to establish whether these projections are real or not.

There is one other area that has been of some concern in terms of going to extended applications of composites in the aircraft business and that is the long term durability. It is well known that on a short term basis, the advantages of strength, stiffness, and weight saving exist; the question is how well these advantages will hold up in the 15 to 20 years that the composite part will have to be in service if it goes on a commercial airplane. So, the program that I am going to be talking about subsequently will be addressing those two issues, the long term durability and the cost item.

About six years ago, NASA started a program with the Boeing Company in which the spoilers of the 737 transport aircraft were selected for redesign with graphite-epoxy composite. The aluminum skins on those spoilers were replaced with graphite-epoxy skins; the rest of the spoiler structure was retained exactly the same as it was in the aluminum production spoilers. A flight article was obtained which was qualified by test and certificated by the FAA for its airworthiness. These spoilers, shown in figure 2, were roughly 0.6 x 1.3 m (22 x 52 inches) in planform, had graphite-epoxy skin, aluminum honeycomb core, aluminum hinges and an aluminum leading-edge spar. The total spoiler weight was approximately 6 kg (13 pounds), of which 35 percent is composite material.

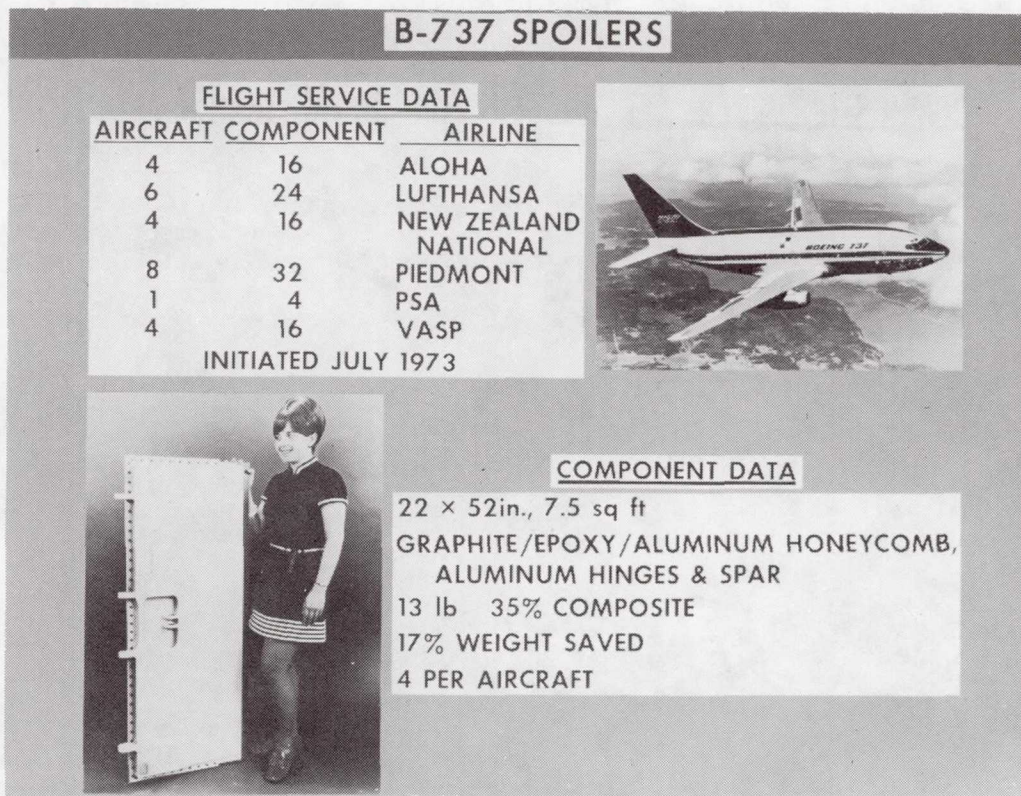

Figure 2

A 17 percent weight saving on these spoilers was obtained by just replacing the skins. Boeing manufactured 108 of these to be installed, four per aircraft, on 27 commercial airplanes. The initial installations were in the airlines that are listed in figure 2 on some of their fleet of 737 transport aircraft. Shortly after the program started, PSA sold four of their 737's to a Brazilian airline, VASP, with the graphite spoilers that were attached. Subsequently, PSA sold their one remaining 737 with graphite-epoxy spoilers to Frontier Airlines.

Spoiler flight service was initiated in 1973, and over 5 years of flight service have been achieved on most of these components. Boeing composite engineers have periodically inspected all of them on the aircraft. In addition, through a scheduled removal system, selected spoilers are removed from service annually, shipped back to the factory at Boeing, and thoroughly inspected by ultrasonics. These spoilers are then tested to destruction to determine if any changes have occurred in residual strength after service, compared with the initial strengths that were established in the original test program. After 5 years of this type of inspection, the graphite-epoxy spoiler is still looking good, the durability is still good, and a long service life is projected. Again, this was not a cost-type program, it was strictly a program to generate confidence in the long term durability of these material.

Figure 3 shows another component of a similar nature, the



Figure 3

graphite-epoxy upper aft rudder, which is flying on eight DC-10 transport aircraft on selected airlines, also to establish some information about the long-term durability. A close-up of this rudder is shown in figure 4. The rudder is over 3.6 m (12 feet) tall. The black portion of this rudder is all graphite-epoxy; there are aluminum hinge fittings on it, the white portions on the leading edge, the trailing edge, and at the top are fiber-glass fairings, but all the rest of it is graphite-epoxy. It represents a rather significant piece of hardware; it is manufactured in a rather innovative type process that molds the complete graphite structure in a single one-piece operation. This is the kind of manufacturing that brings down the number of man-hours required in assembly of pieces of sheet metal by riveting, and therefore projects a cost-effective method of manufacturing for a finished piece of hardware like this rudder. Of the eight rudders that are in service, some have been flying as long as 2 1/2 years and the service experience with these has been entirely satisfactory. They are also inspected on a periodic basis by both airline maintenance and Douglas composite engineers.



Figure 4

The first civil production commitment to composites that has occurred right from the very beginning of the design of a new aircraft happens to be with the Sikorsky S-76 helicopter, shown in figure 5. In this figure the three prototype helicopters that are being used in the flight certification program are shown. The main spar of the tail rotor is graphite-epoxy. There is a graphite-epoxy reinforcement of the spar of the horizontal stabilizer. There is also graphite-epoxy in a reinforcing mode in several of the doors and fairings in the forward portion of the helicopter, and there is a graphite-epoxy linkage in the root end of the main rotor blade system. All in all, there is somewhere between 20 and 23 kg (45 and 50 pounds) of graphite-epoxy composite in this production commitment by Sikorsky to this new helicopter. It is expected to have widespread usage, initially in the oil field support role, and later branching out into a much larger area of civil application.

Several years ago, NASA decided to try and accelerate the technology development of key areas for fuel savings through the ACEE (Aircraft Energy Efficiency) program. One part of this program is the ACEE composite structures which is trying to establish a firm base for manufacturing cost projections on selected components. The ACEE composites program deals with two sets of civil aircraft structures - secondary structures and medium primary structures.

FIRST PRODUCTION COMMITMENT OF GRAPHITE-EPOXY TO CIVIL AIRCRAFT - SIKORSKY S-76 HELICOPTER



Figure 5

Components in the secondary structures area are shown in figure 6. The elevator on the 727 was selected by Boeing as a demonstration article for the manufacturing development program. Douglas selected the upper aft rudder on the DC-10, because based on the experience of the first 10 rudders that had been manufactured in the R&D program, they believed that there were some significant changes which could be made in their manufacturing technique, and which would do an even better job of driving the manufacturing costs down on an article of that type. Lockheed chose the aileron on the L-1011, and that also is a graphite-epoxy component and is being worked very hard at the present time in both design and manufacturing.

These three secondary structural components have some rather interesting characteristics, as shown in figure 7. The design weight of the composite part is the total weight of that part as it would be installed on the aircraft. In the case of the elevator, the weights are for only one-half of the elevator, which was all that was in the early part of the development program. For a flight article a complete ship set is needed, so those weights would be doubled. There are some rather significant poundages involved here as compared with the original flight service component weights of the spoilers. The aileron weight is also a single, left-hand unit weight. For a ship set for flight, a minimum of two ailerons would be needed. The interesting thing here is the expected weight savings of 25 to 33 percent, which has now been verified in several of these articles. That is significant from the standpoint that weight saving translates directly in a retrofit program into fuel savings, or into increased payloads. For a new design with these kinds of materials and these kinds of weight savings in hand right from the beginning, a synergistic effect will produce even greater benefits than just the direct weight savings on that particular component.

The last column of figure 7 gives the carbon-epoxy composite weight in each of these components. In every case, the amount of composite that is used is a relatively small part of the total component weight. That is because of items like metal hinges and fittings that just cannot be replaced in the present state of technology, and in these kinds of secondary structures they account for a significant part of the total component weight. But even for this situation, significant weight savings are obtained on the total component. The carbon fiber weight in these components is about 70 percent of the carbon-epoxy composite weight in the last column. The epoxy matrix is the other 30 percent. One gram of carbon fiber, if broken or cut into one centimeter lengths, will produce about one million individual fibers, or one pound will yield about one billion fibers. Even at small fractions of fiber released in a fire accident, there may be large numbers of single carbon fibers released from the kind of poundages of structures that are shown.

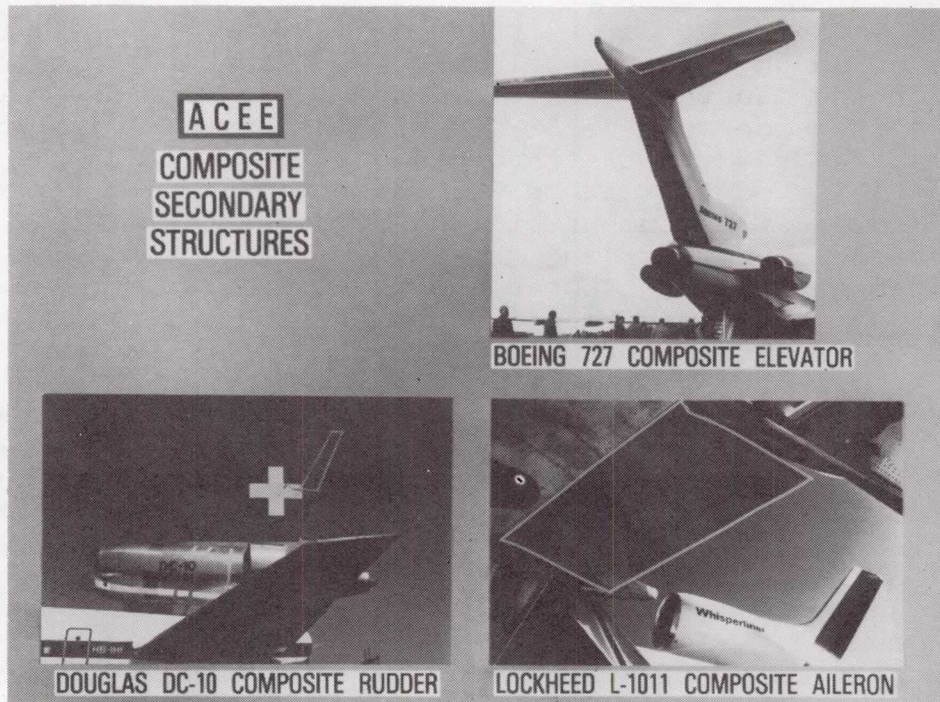

Figure 6

ACEE COMPOSITE SECONDARY STRUCTURES

COMPONENT	COMPOSITE DESIGN ESTIMATED WT. LB	EXPECTED WT. SAVINGS %	CARBON-EPOXY COMPOSITE ESTIMATED WEIGHT, LB
727 ELEVATOR	211	26	49
DC-10 RUDDER	61	33	27
L-1011 AILERON	105	25	55

Figure 7

Turning next to the composite primary structural components, figure 8 shows pictures of the selected components. For these ACEE programs, the aircraft companies selected a horizontal stabilizer on the 737, the vertical stabilizer on the DC-10, and the vertical fin on the L-1011. These begin to get to be sizeable pieces of structure, up to 7.6 m (25 feet) long. The estimated weights on these components, given in figure 9, are significantly greater than those for the secondary components. The weight savings are not as great because it is primary structure and more attention has to be paid to load-carrying capabilities, as opposed to just stiffness. The weight savings are still very significant in the 20 to 27 percent range, as opposed to the 25 to 33 percent for the secondary structures. But a more significant factor is the much larger percentage of the total component weight that is carbon composite. As the components get larger, the metal fittings become less in terms of the percentage of weight that is involved.

All six of these ACEE programs are still very active. They are driving towards developing the manufacturing expertise on these types of components that will be building multiple components and are tracking the costs throughout all the operations in manufacturing so that a reasonable type of learning curve can be obtained. The preliminary indications are that in almost every case, at some reasonable number of units downstream, these composite components would become cost effective; that is, they would be cheaper to make



Figure 8

ACEE COMPOSITE PRIMARY STRUCTURES

COMPONENT	COMPOSITE DESIGN ESTIMATED WT. LB	EXPECTED WT. SAVINGS %	CARBON-EPOXY COMPOSITE ESTIMATED WEIGHT, LB
737 HOR. STAB.	183	27	163
DC-10 VERT. STAB.	743	20	489
L-1011 VERT. FIN.	645	25	503

Figure 9

as composite parts to put on the aircraft than the existing aluminum parts for that same aircraft. It is kind of a preliminary estimate in this stage of the game. The programs all have a year or more to go before they have the final cost figures and about all that can be said is that it looks optimistic at this stage that the manufacturing costs are going to be down on these types of elements.

The final figure, figure 10, outlines briefly some of the principal areas of projected usage in civil aviation for graphite composite. Dr. Harris' talk presented several curves that projected the total aerospace poundage that might be used in the years 1990 to 1993. The bulk of that usage is going to come in transport aircraft. Using things like the ACEE technology on empennage components, on control surface components, and wing trailing edge structure, and applying that technology on the next generation of aircraft will project usages of at least the order of 450 kg (1000 pounds) of graphite composite per aircraft. How rapidly that gets translated into the total fleet, of course, will depend on sales history. Based on some discussions with the manufacturers, it appears that by 1993, approximately 50% of the civil fleet will be carrying significant amounts of graphite composites in their structures. In the helicopter business, there probably will be at least as many of the civil helicopters carrying significant amounts of graphite composites, but the total impact

CIVIL AVIATION USAGE OF GRAPHITE COMPOSITES

- TRANSPORT AIRCRAFT
- HELICOPTERS
- GENERAL AVIATION AIRCRAFT

Figure 10

in terms of volume or pounds of composites will not be as great because the total weight of the helicopter structure is not as great as that of the civil transport aircraft. The percentage of composite will be large, but the total weight is small so the total amount of the composites will be relatively small. In the general aviation portion of the market there will be many more aircraft manufactured, but to date general aviation has taken a very small look at the possibilities of advanced composites, particularly graphite composites for application in their aircraft. The first area of application will probably be in the executive aircraft and probably in some of the flight control surfaces, borrowing from the technology of the civil transport manufacturers to update and upgrade the performance of the executive type jets that are being produced by general aviation. A big penetration of composites in this market is not anticipated through the 1990 time frame. However, it is an area that could grow rapidly. There are enough aircraft being manufactured that if only a few pounds were used on each one, it could still get to be significant total poundage compared to some of the other areas. Sooner or later they will get the manufacturing costs for their applications down to where it becomes competitive and then that part of the civil aviation program will grow rapidly, but at the moment the big user appears to be the civil transport aircraft in the 1990 time frame.

Question:

Is there any reason other than material properties that prevents the manufacturers from using the composites in other components of the aircraft, say more in the basic structural framework rather than empennage and wing trailing edge surfaces?

Answer:

I think it is again a question of level of confidence; when you begin to consider components like the main wing box structure, for example, you are committing extremely large capital resources to acquire the facilities to build that kind of structure with composite manufacturing techniques as opposed to building the smaller pieces which can be handled pretty much in existing or near term type facilities. I think it is largely that kind of thing, plus again some increased concern about the long term durability of major components which are not so readily repaired or replaced, if the situation should subsequently require it. The ACEE program has had three composite wing study contracts, the final reports are just in the process of being released, and they provided a preliminary look at this question of what is required and when could we go to a full wing type structure.

Question:

I understand that the 747 has carbon fiber floor panels. Is that correct?

Answer:

We have some Boeing representatives here who might care to comment on that specific question. To my knowledge they are not a production commitment at the present time. There are a number of them that are in-service as part of a company evaluation program of the performance of these panels, but I do not believe that Boeing has made a production commitment of these in the 747 line. Would anybody from Boeing care to comment on that?

Answer:

Cory McMillian, Boeing. That is correct, it is not a production commitment.

Vernon L. Bell
NASA Langley Research Center

The first of the elements in the Langley risk analysis program is concerned with the source of released carbon fibers. Although there have been, to our knowledge, no crashes of civilian aircraft containing carbon composite parts, there have been several crashes of military planes carrying carbon composites which have demonstrated the high potential for the release of carbon fibers from the ensuing fires. With this military experience and the body of accident statistics for commercial aviation to draw on, we must face the inevitability of crashes and fires involving commercial aircraft with carbon fiber composites.

In the absence of actual experience, we have had to study ways to simulate the conditions of aircraft crash fires in order to predict the quantities and forms of fibrous materials which might be released from civilian aircraft crashes/fires. The following figures will describe some typical fiber release test activities which have been conducted, together with some very preliminary results of those activities. Following that, the status of our knowledge of carbon fiber release from simulated aircraft fires will be summarized, as well as some of the uncertainties in our knowledge of accidental fiber release.

Prior to NASA's involvement in the carbon fiber program, most of the knowledge of carbon fiber release resulted from investigations by the Navy. This testing is outlined in figure 1. Most of the fundamental studies of the burning of carbon fiber composites and fiber release were conducted at the Naval Research Laboratory, where the rates of composite combustion at low, moderate, and high fire temperatures were studied. The NRL researchers also noted the formation of a char, or "coke," resulting from the combustion of the epoxy resins. This char was observed to serve as a binder which tended to prevent the release of single carbon fibers from the burned composite residue. When single fibers were released, they were generally short. The NRL workers observed that some form of agitation was required to release any significant number of single fibers, and they also found an effect of thickness; that is, the thinner the composite, the more readily fibers were released.

The Navy's Dahlgren, Virginia laboratory developed a test involving a burn/explosion cycle for studying carbon fiber release. From the testing of one square foot flat composite plates in the chamber, they demonstrated there was a minimal release of carbon fibers when the composite was burned only, without the explosion. They showed that the same minimal release resulted when the

PRE-NASA CARBON FIBER RELEASE TESTING

NAVAL RESEARCH LABORATORY

- STUDIED COMPOSITE BURNING RATES
- NOTED EPOXY CHAR BINDER ON FIBERS
- OBSERVED SHORT LENGTHS OF RELEASED FIBERS
- NOTED TURBULENCE REQUIREMENT FOR RELEASE OF FIBERS
- NOTED COMPOSITE THICKNESS EFFECT

NAVAL/DAHLGREN CHAMBER

- DEVELOPED BURN/EXPLODE FOR COMPOSITES
- DEMONSTRATED MINIMAL RELEASE FROM BURN ONLY
- DEMONSTRATED MINIMAL RELEASE EXPLODED ONLY
- OBTAINED 15-20% SINGLE FIBER RELEASE FROM BURN/EXPLODE

Figure 1

composite was impacted explosively, without burning off the resinous binder. From the burning and exploding of the flat composite plates, they obtained 15-20% release of single fibers and lint (clusters of several single fibers), based on the amount of carbon fibers initially present in the composite.

This Navy work was pioneering and many of the results cited in the following presentation are in keeping with the Navy studies; the NASA results generally confirm or quantify those earlier findings.

The carbon fiber release test facilities listed in Figure 2 are those which have been closely coordinated into a NASA test program. The laboratory studies, which are of an exploratory nature, are being conducted at both the Langley and Ames laboratories of NASA. The chamber studies are those which not only burn and agitate or impact the composites, but also collect, measure, and count the fibrous residues which are produced. The only outdoor or range fiber release testing was done in the spring of 1978 by TRW, Inc., under the sponsorship of the Air Force and with the cooperation of the Navy at the Naval Weapons Center, China Lake, California. Presently, NASA has contracted with TRW to complete the reduction and analysis of the data resulting from

NASA CARBON FIBER RELEASE
TEST FACILITIES

LABORATORY	-	NASA - LANGLEY NASA - AMES
CHAMBER	-	NASA - AMES NAVY - DAHLGREN AVCO CORPORATION
OUTDOOR	-	AIR FORCE/NAVY/TRW - CHINA LAKE

Figure 2

those tests, and for that reason, it is considered an ongoing test activity.

Some typical results from the simulated release of carbon fibers from laboratory testing will now be presented.

The information presented in figure 3 is intended to give a perspective on the thermal characteristics of carbon fibers. The comparative levels of heat resistance of several carbonaceous materials are presented by means of the thermogravimetric analysis of the carbon forms. Thermogravimetric analysis simply involves the heating of a material at a certain rate and in a particular environment (in this case at a rate of 5°C/minute in air) and measuring the subsequent weight loss. Obviously, diamond is the most thermally stable form of carbon, although it can still be burned if it is heated sufficiently high with enough air present. At the other extreme are the organic resins, in this case epoxy, which begin to lose weight when heated to a relatively low temperature, and which are almost completely burned up, except for a small amount of char, at about 400°C. Pyrolytic graphite is a relatively stable form of carbon, and some of the more "graphitic" fibers, such as GY 70, resist heat almost to the same degree as pyrolytic graphite. Fibers such as AS and T300 display thermogravimetric curves virtually identical to that of carbon

THERMOGRAVIMETRIC ANALYSIS OF CARBONACEOUS MATERIALS

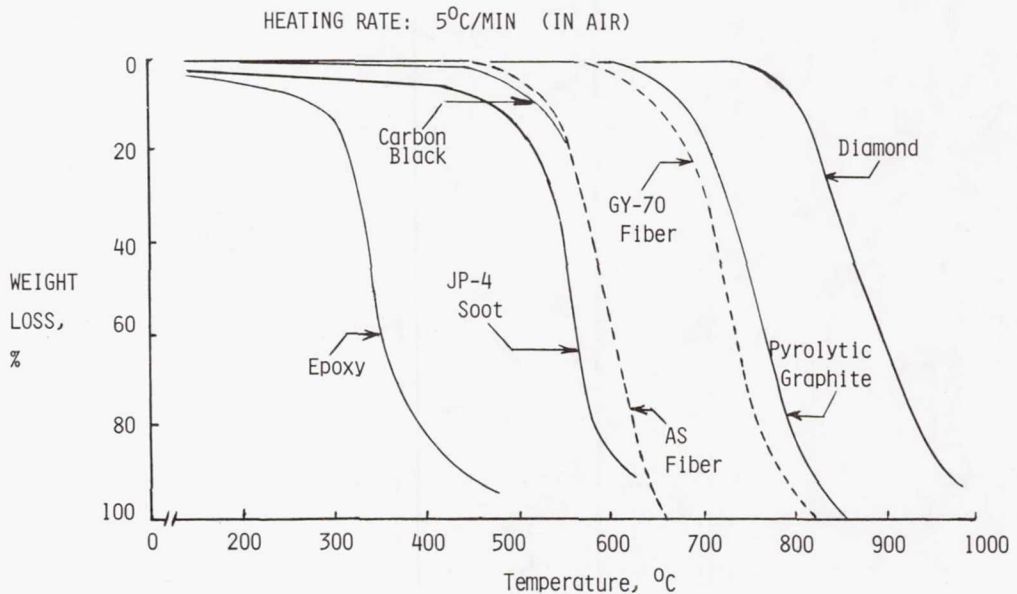

Figure 3

black, confirming the manufacturer's opinions that those products are carbon, and not graphite, in nature. The lower level of stability of JP-4 soot probably reflects the incomplete carbonization of the fuel precursor.

Although thermogravimetry is only a simple tool for studying thermal behavior of materials, some obvious things are apparent from this figure. In a fire, the first part of a carbon/epoxy composite to burn off will be the epoxy resin, and even the epoxy char will completely burn up before the fibers. Further, if JP-4 soot (or other jet fuel residues) are given off, it's an excellent bet that carbon fibers will survive the fire and be available for dispersion. And lastly, it is apparent that the thermal resistance of carbon/graphite fibers differ considerably, and that difference must be considered in assessing the potential release of fibers from a fire.

The apparatus shown in figure 4 is called the "Toonerville Trolley" at Langley, where it was built for the burning of composites with jet fuel. Most of the early composite burn work has been performed using "clean" propane fuel, because of the difficulty in analyzing the results of fiber release when composites are burned with messy, sooty, kerosene-based fuels. This

COMPOSITE BURNER



Figure 4

burner has been used fairly successfully at Langley to burn small composite samples, about 2" x 2" in size, with the oxidation products being carried through the inverted "U" stovepipe into the chamber at the bottom, where the fibers and large soot particles are filtered before exiting to the outside.

Figure 5 shows the results of burning several different virgin fibers, not composites, in the Langley oil burner. It is apparent that the two fibers most commonly used in aerospace composites, AS and T300, were completely oxidized in the short time of 1-1/2 minutes at 800°C, which is a moderate-to-low JP-4 fuel fire temperature. On the other hand, the more so-called "graphitic" fibers, Celion and HMS, are barely affected by the fire in the first 1-1/2 minutes, although prolonged exposures of 3 and 10 minutes at 800°C do burn them to a considerable extent. However, exposures of Celion and HMS to the hotter fire temperature of 1000°C causes large weight loss in rapid order, and at the very hot JP-4 fire temperature of 1200°C, even HMS can be burned completely in short order. These results support the proposition given previously that the differing thermal behavior of various fibers must be considered in studying carbon fiber release from fires.

OXIDATION OF CARBON FIBER WITH JP-4

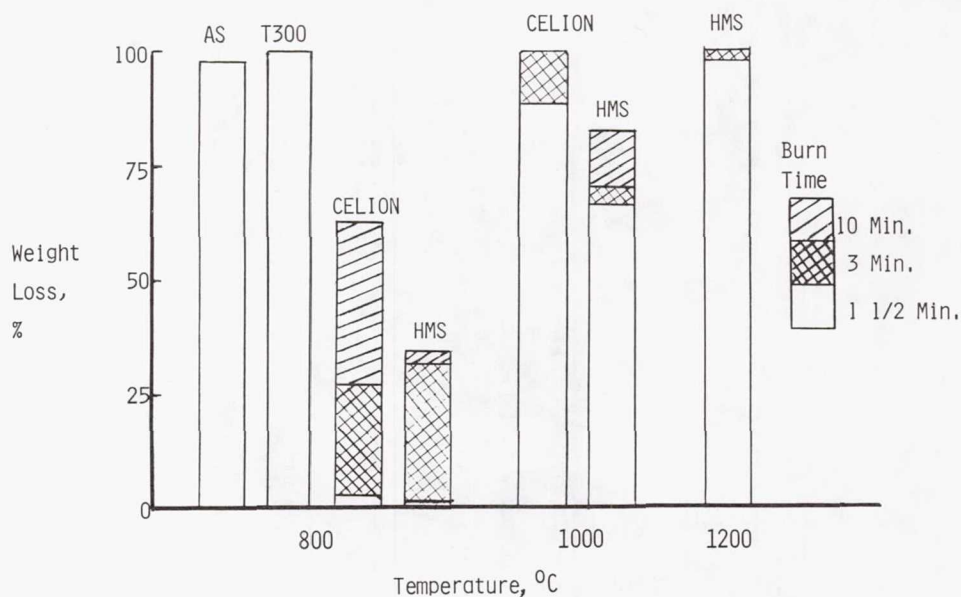

Figure 5

The previous figures have shown some results from laboratory testing, which has been relatively fundamental in nature. The next investigations to be reported deal with the simulated release of fibers by means of chamber testing.

The tests at the Naval Surface Weapons Center, Dahlgren, Virginia are conducted in a room within a large hemispherical chamber. The room is approximately 40 ft x 24 ft in size, with about 10 ft ceilings, as shown in figure 6. Composite specimens, preferably about 1 ft² in size, are mounted horizontally in the test fixture in the middle of the room. A propane burner, shown to the right of the test figure, is swung beneath the sample, which is burned for the desired time, up to 20 minutes. The burner is then swung away, and a conically-shaped explosive charge on the left is swung beneath the burned composite residue and detonated. The fibers and fragments from the composite are thrown throughout the room and deposited on 8" x 10" pieces of "sticky" paper laid out in a grid over the room. The sheets of paper are then removed and a representative sample of the grid is then counted by a statistical technique at Dugway Proving Ground in Utah. Only single fibers are precisely counted by that method, but a crude mass balance of the residue produced from each test is obtained via hand-pickup, sweeping, and vacuuming.

NAVY-DAHLGREN CHAMBER TESTS

SAMPLE SIZE :

6" × 6" OR 12" × 12"

FIRE TEMPERATURE :

HIGH (2100°F)

FIRE FUEL :

PROPANE

IMPACT :

HIGH (2 oz OF C-4
EXPLOSIVE)

BURN/EXPLODE RESIDUE :

SECONDARY IMPACTS ;
FULL RECOVERY

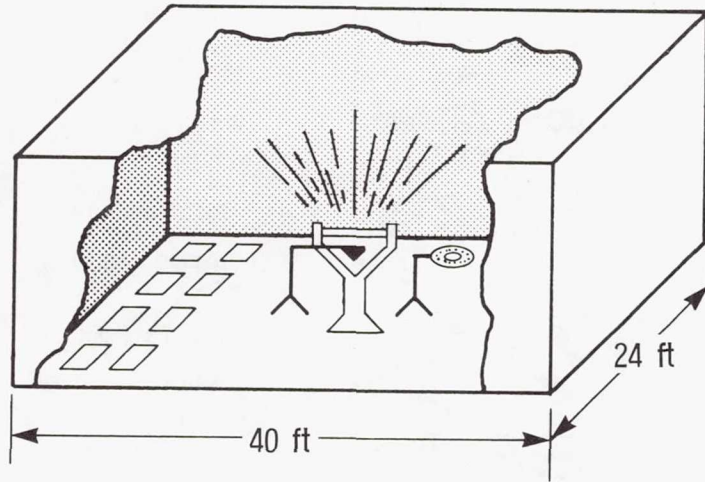

Figure 6

The conditions of this particular test method, from the standpoint of simulating an aircraft crash/fire scenario, are considered to be quite extreme. The fire temperature (2100°F) is fairly high, and certainly the impact produced by 2 ounces of C-4 explosive must be almost unrealistically high, at least for most commercial aircraft crashes. An undesirable effect of this test may be the fact that there is an opportunity for secondary impacts (against the ceiling and walls) of the blast fragments. However, a very desirable feature of the Dahlgren test is the complete recovery of all burn/explosion products.

Six representative fiber release categories designated by the Dahlgren test personnel are shown in Figure 7. Of most concern to date have been the first two, single fibers and lint consisting of several single fibers clumped together, due to their relatively low settling rates. The third category, the brush clump which looks rather like a paint brush, falls at such a rate to probably preclude its dispersion for long distances. The three blast fragment categories, arbitrarily divided up by sizes, probably represent a threat only to open electrical equipment in the immediate vicinity of the fire/explosion.

FIBER RELEASE CATEGORIES







	Category	Fall Rates
	1 - Single Fibers	3.2 cm/sec
	2 - Lint	22 cm/sec
	3 - Brush/clump	88 cm/sec
	4 - Blast Fragments Width < 2 mm	152 cm/sec
	5 - Blast Fragments Width 2-7 mm; Length < 25 mm	167 cm/sec
	6 - Blast Fragments Width > 7 mm, Length > 17 mm	189 cm/sec

Figure 7

Prior to NASA's involvement, the Dahlgren test program had been confined to the burning of simple, flat composite plates. NASA then initiated a joint test program with the Navy to determine the relative tendencies for carbon fibers to be released when real composite aircraft parts are burned. Using the Dahlgren test chamber and burn/explosion sequence, a number of parts, as listed on figure 8, have been tested. Of those listed, only the results from the 737 spoiler and DC-10 rudder tests are complete.

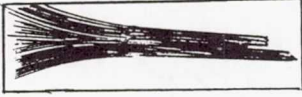
This photograph of the 737 spoiler in figure 9 shows how the part was cut along the indicated grid of lines into a number of test specimens. The spoiler itself consists of 6-ply and 8-ply carbon/epoxy skins, with aluminum honeycomb between the skins. Since there was also a substantial amount of metal, in the form of the honeycomb, hinge fittings and frame, and close-out edges, etc., there was an opportunity to find if such factors as part thickness, metal content, etc. would influence the amount of single fiber released from the various specimens. The one-foot rule shown gives an idea of the size of the part, which is 22" x 52".

The results of the spoiler and rudder burn/explosion tests have been summarized in figure 10. A very definite finding was that the bulk of the single fibers released were very short - less

NASA/NAVY
COMPOSITE PARTS BURN TEST PROGRAM

- OBJECTIVE: DETERMINE RELATIVE TENDENCIES FOR FIBER RELEASE FROM ACTUAL COMPOSITE AIRCRAFT PARTS
- TEST FACILITY: NAVY CHAMBER AT DAHLGREN, VIRGINIA
- TEST PROCEDURE: BURN (PROPANE), BURN PLUS EXPLODE
- PARTS TESTED:
 - A. 737 SPOILER
 - B. DC-10 RUDDER
 - C. L-1011 AVF (MISCELLANEOUS TEST SPECIMENS)
 - D. 747 FLOORING
 - E. QCSEE FAN BLADE

Figure 8

737 SPOILER USED IN BURN TESTS

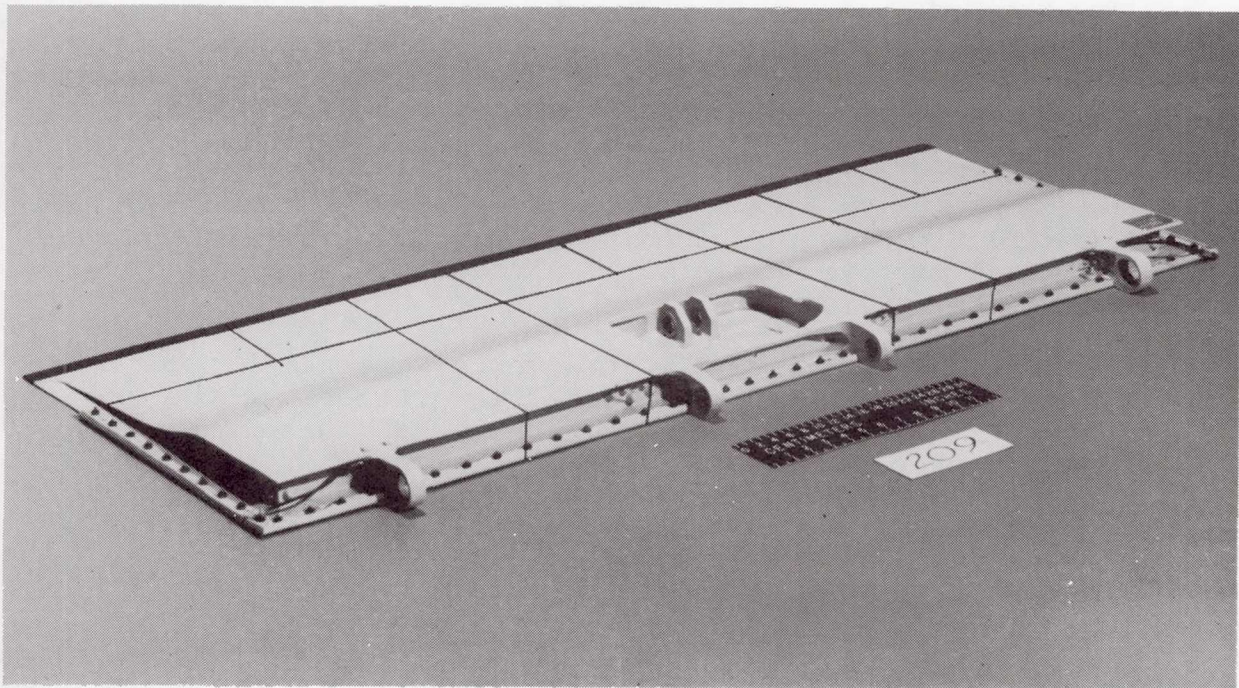

Figure 9

RESULTS OF BURN/EXPLODE TESTS ON
COMPOSITE SPOILER AND RUDDER

- SINGLE FIBERS ARE PREDOMINANTLY SHORT (≤ 3 MM)
- EXTENDED BURN TIMES YIELD LESS SINGLE FIBERS
- COMPOSITE PARTS WITH NON-COMBUSTIBLES YIELD LESS SINGLE FIBERS
- FEWER BLAST FRAGMENTS FROM SPOILER AND RUDDER THAN FROM THICK PLATES
- BURN/EXPLOSION OF RUDDER RELEASED 10% SINGLE FIBER
- BURN/EXPLOSION OF SPOILER RELEASED 12% SINGLE FIBER

Figure 10

than 2 millimeters in length. Qualitatively, it was noted that lengthy burn times resulted in the release of less single fibers, suggesting that the carbon fibers will burn up if given sufficient time. It also appeared that those specimens containing large amounts of noncombustible materials, such as metal and glass fiber, released less single fibers. The reason is not known, but perhaps the metal serves in some way as a heat sink to moderate the thermal effect on the composite; perhaps too, the aluminum honeycomb softens the impact of the explosive force on the composite skin.

Not surprisingly, fewer blast fragments were given off from the thin skins of the spoiler and rudder in contrast to the amount given off from thick composite plates. Although the amounts of single fiber released from individual test specimens varied widely, weighted averages of single fiber released from the rudder and spoiler tests were 10% and 12%, respectively. However, it should be emphasized that these quantities are single fiber only, and the results do not reflect the amounts of other fibrous residues which might represent a threat to electrical equipment.

A study to determine the effects of the various materials and structural parameters of composites on fiber release has also been conducted using the Navy's Dahlgren facilities. Fiber/resin

compositions, laminate thickness, and layup configurations have been investigated by burning and exploding composite panels which have the variations indicated in figure 11. Although the actual tests have been completed, quantitative results which will reflect the relative amounts of fibers released are not yet available. However, we do have some indication of the relative importance of the parameters being studied.

COMPOSITE MATERIALS PARAMETERS STUDY

OBJECTIVE: DETERMINE RELEASE OF FIBER FROM RESIN/FIBER, THICKNESS, AND LAYUP VARIATIONS

APPROACH: BURN AND BURN/EXPLODE GRAPHITE/EPOXY PANELS IN NAVY/DAHLGREN CHAMBER; MEASURE RELATIVE AMOUNTS OF FIBER RELEASE

PARAMETERS: o FIBER/RESIN: T300/5208, AS/3501
o LAMINATE THICKNESS: 1/16" , 1/8" , 1/4"
o LAYUP: UNIDIRECTIONAL, CROSSPLY, WOVEN

Figure 11

Figure 12 is a photograph of the fiber residue which remained after a 2" x 2" unidirectional composite sample was burned with JP-4 fuel in the Langley "Toonerville Trolley" oil burner. The result is a rather firm, biscuit-like residue which retains the integrity of the fiber as it was laid up in the fabrication of the composite panel. It appears that fibers resulting from burned unidirectional composites naturally resist being released individually, either by virtue of the small amount of epoxy char which binds them together, or else as a result of the "cohesivity" of the fibers as they lay intimately in contact with each other for their entire length.

Figure 13 is a photo showing the results of impacting the unidirectional fiber residue "biscuit" with a .38 caliber prime load. An impact is required to cause such a fibrous residue to break up and permit the release of individual fibers.

FIBER RESIDUE FROM UNIDIRECTIONAL COMPOSITE



Figure 12

IMPACTED RESIDUE FROM UNIDIRECTIONAL COMPOSITE

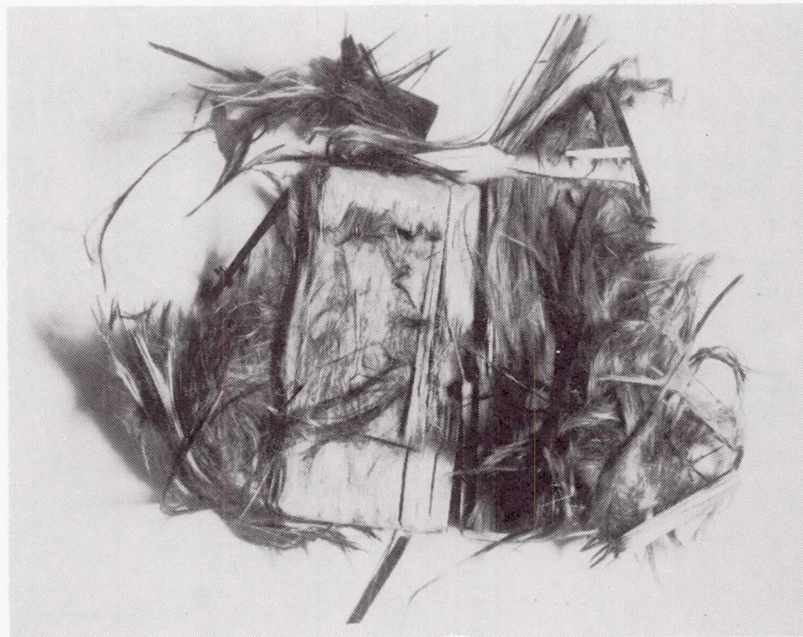

Figure 13

The photo in figure 14 shows the manner in which the burning of the epoxy resin from cross-plyed carbon/epoxy composites causes

RESIDUE FROM CROSS-PLY COMPOSITE

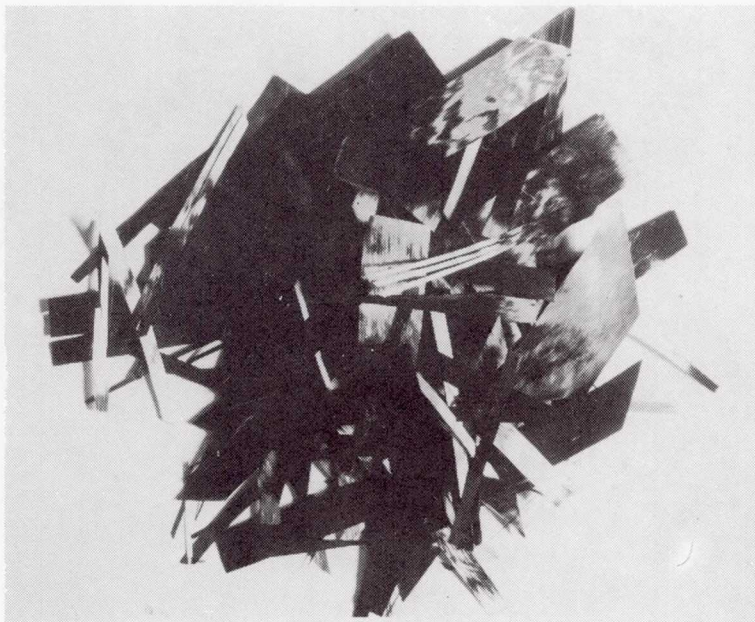

Figure 14

the individual plies to separate with no impact at all. It is apparent that the strength of cross-plyed composite residues is very weak in the thickness direction, an observation in keeping with a knowledge of the mechanical properties of the unburned composites. Incidentally, the residues resulting from the burning of cross-plyed composites in the crash fire of a military aircraft were virtually identical to those shown here from a test specimen.

The residue shown in the figure 15 photo resulted from burning a carbon/epoxy composite fabricated from woven carbon fiber, a method finding more and more use due to the ease of working with that form of fiber. Obviously, the weakness in this form of composite is also in the thickness direction of the composite, causing the individual plies to fall apart simply by burning off the adhesive epoxy resin. However, it also appears that the woven fiber residue must have a great tendency to resist the release of single fibers unless a substantial impact or agitation is applied to the burn residue.

Some preliminary results reflecting the effect of composite thickness on fiber release is shown in figure 16. Although fiber count from these tests is not yet available, a mass balance which

RESIDUE FROM WOVEN COMPOSITE

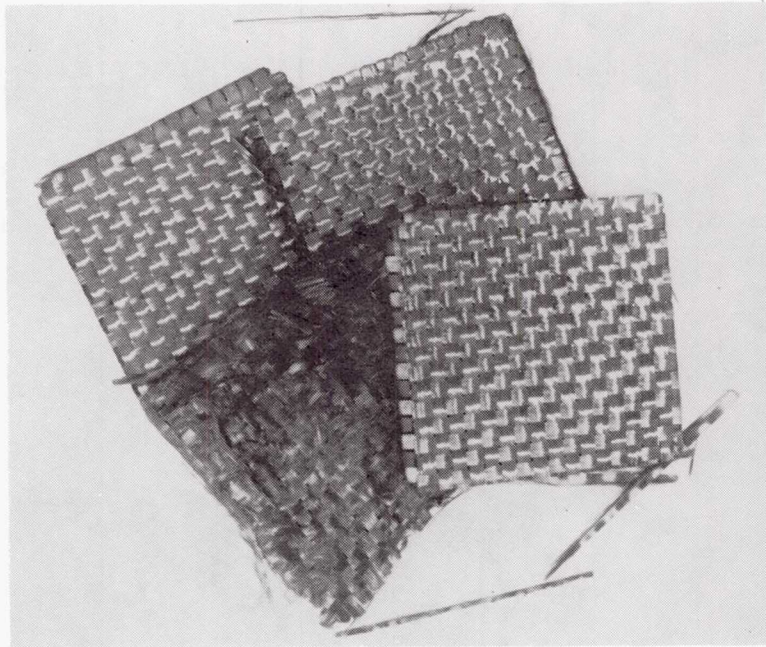

Figure 15

EFFECT OF COMPOSITE THICKNESS ON
RELEASE OF FIBROUS PARTICLES (PRELIM.)

DAHLGREN BURN/EXPLODE TEST
AS/3501 CROSS PLY PANELS

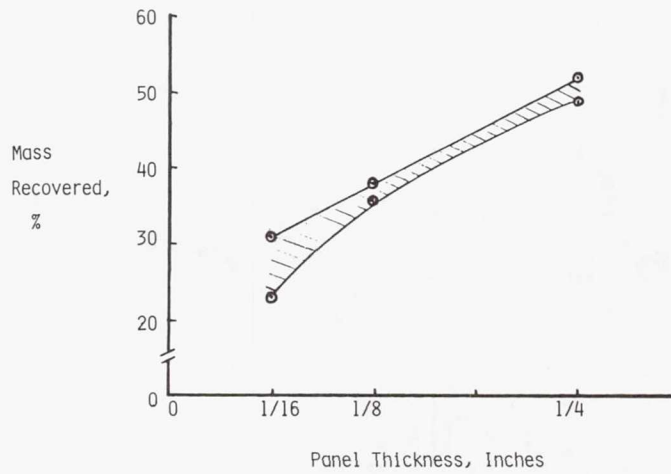

Figure 16

includes all forms of fiber residue resulting after the burn/explosion of six composite panels of three different thicknesses clearly indicates that the thinner the composite skins, the more fiber will be burned away. It should be stressed that this would be expected given the identical flame conditions. Nevertheless, it lends substance to early observations made by a number of researchers, included those at the Naval Research Laboratory.

Figure 17 diagrams the fiber release test facility at Redwood City, California which is being operated for NASA - Ames, and is just beginning to generate useful fiber release data. The major portion of the facility is at the right and includes a burner system using highly radiant gas burners, with provisions for nitrogen to cool the temperature or to modify the fire environment. The sample, preferably a 1 foot by 1 foot composite panel, is mounted horizontally as shown in the fire chamber. After the sample has been burned for the desired period of time, a projectile of a chosen weight is dropped from a chosen height and impacts the center of the burned composite sample. Immediately upon impact, a cover falls over the impacted sample to contain all the impact residue. The residue is then collected and counted to complete the test. At the present time, this facility is designed only to study burn and impact test cycles. However, NASA-Ames does plan to modify it to study burn-only situations. The scrubber-cooler is utilized to remove any carbon fiber which might be inadvertently carried in the gas flow stream, and a high

FIBER RELEASE TEST FACILITY AT REDWOOD CITY, CALIF.

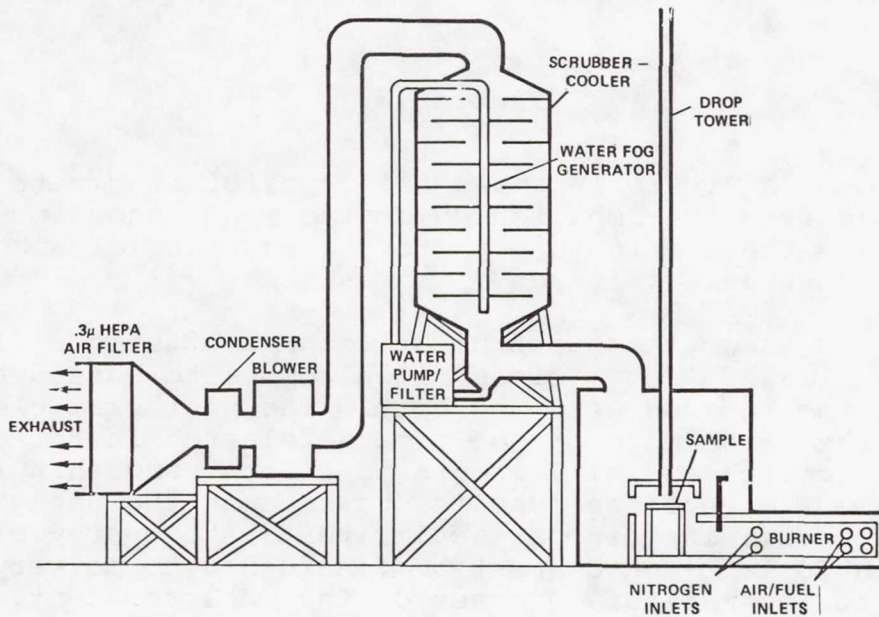

Figure 17

efficiency filter serves to make certain no fiber is released to the outside environment.

The photograph in figure 18 shows the state of a burned composite test panel after the impact. The cross-plyed composite is seen to be severely shattered by the impact, suggesting the presence of some residual epoxy char has tended to hold the individual fibers together.

BURNED COMPOSITE TEST PANEL AFTER IMPACT

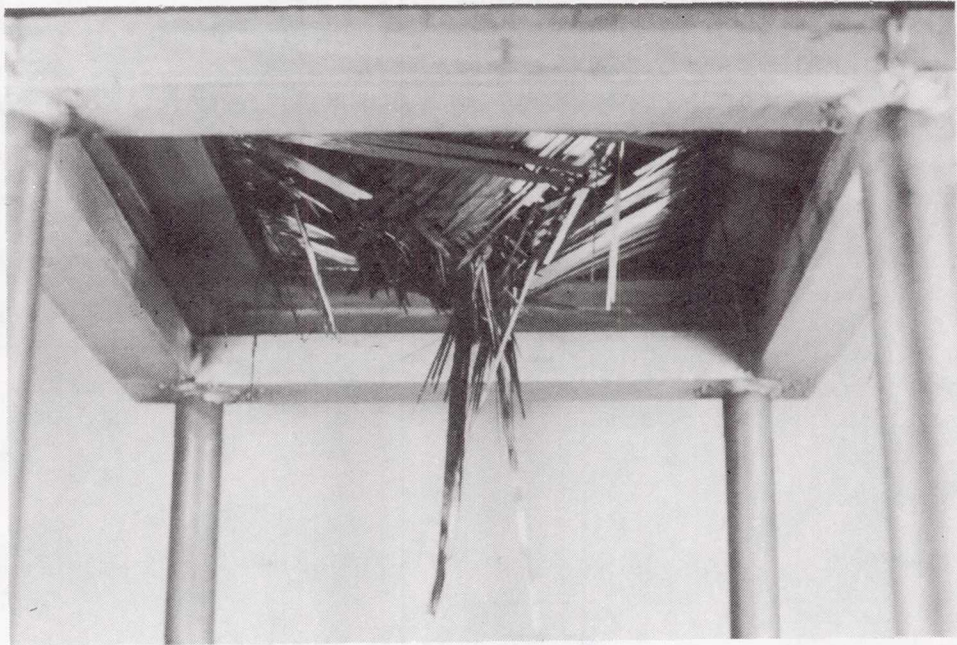

Figure 18

The photo in figure 19 shows the types of fragments which were released from the impacted composite panel shown previously. Not visible to the eye in this photo are any single carbon fibers which might have been released.

Figure 20 shows the spectrum of lengths of single fibers which were released from a cross-plyed composite burned and impacted in the Redwood City facility. The histogram clearly shows that the large majority of fibers released in this test were very short, less than 3 millimeters in length, and this finding is in agreement with those results obtained in the Dahlgren test chamber. However, in this particular test, the energy of impact of less than 60 foot-pounds must be considered to be very low in comparison to the explosive impact of the Dahlgren test, and indeed the amount of single fibers released in this test was very slight: less than 0.1% of the weight of carbon fiber initially

FRAGMENT TYPES RELEASED FROM IMPACTED COMPOSITE PANEL

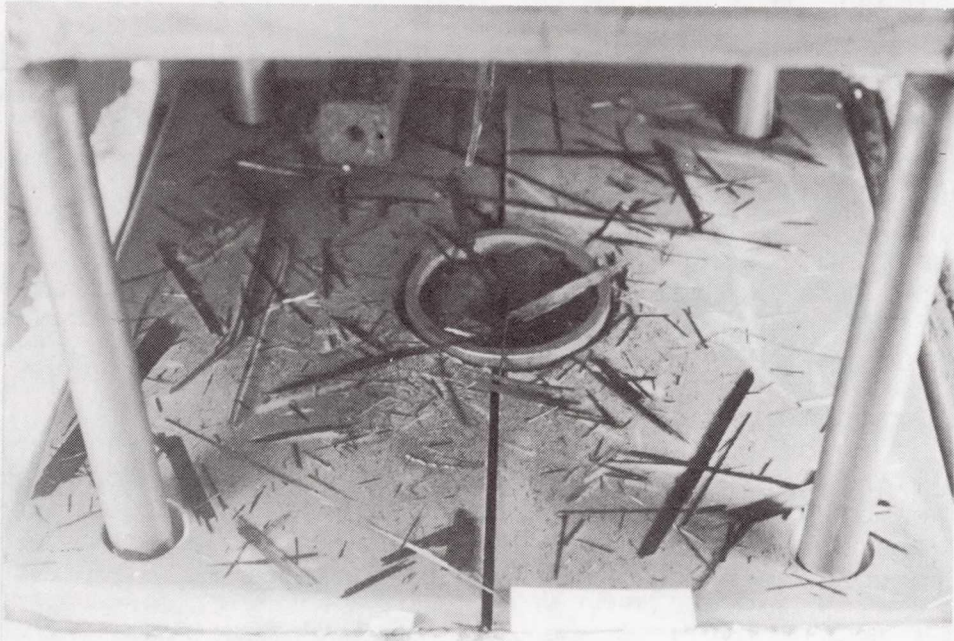

Figure 19

FIBER LENGTH SPECTRUM

Tested at NASA/Ames-Redwood Facility

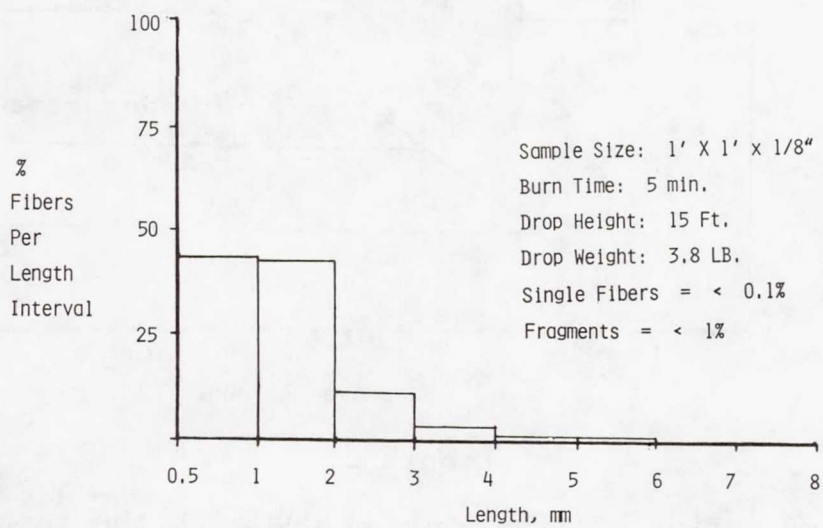

Figure 20

present in the composite panel. Furthermore, the quantity of total fragments released in this test, less than 1% of the total carbon fiber in the composite, was far less than the total fragments released in the Dahlgren test.

Figure 21 pertains to a very interesting and potentially useful test activity being conducted at the Navy's Aircraft Survivability Laboratory at China Lake. Some of the conditions which might be present during an in-flight fire are simulated by placing a 6" x 6" x 1/2" composite panel, which in some cases has a round hole or notch cut through it and in others has a slot cut across the entire leading edge of the panel, over a fire box containing burning jet fuel. Air at various velocities is passed over the test panel and the rate of composite material loss is determined. The results shown in this figure show that the rate of mass loss increases with exposure time and then reaches a constant rate for each air speed. Presently, the test only determines mass loss, but plans are being made with the assistance of NASA - Ames personnel to monitor carbon fiber loss from the burning panels. Such a test could be very useful in answering future questions regarding release of carbon fibers from composite-containing aircraft which would be burning in flight.

SIMULATED IN-FLIGHT COMPOSITE FLAMMABILITY TEST

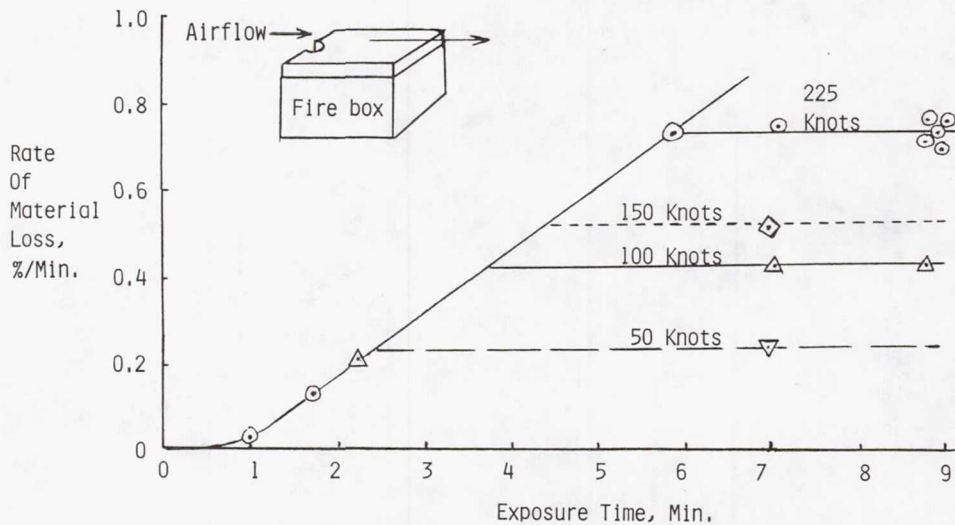

Figure 21

The next series of figures will describe the results of the only large scale outdoor composite burn tests to have been carried out to date.

These tests are outlined in figure 22. TRW began its series of outdoor burn and fiber release tests for the Air Force by burning three standard one square foot composite plates in separate tests, followed by an explosion to impact the fibrous residue in a unique but simple outdoor facility at their Capistrano, California Test Site. These tests, which were intended to parallel the conditions of the Dahlgren test, were conducted in a 15 foot by 15 foot tent with screen walls, thus allowing for the retention of all but the finest burn/blast fibers and fragments.

AIR FORCE/TRW OUTDOOR

COMPOSITE BURN AND FIBER RELEASE PROGRAM

o CAPISTRANO

THREE 1 ft² X 1/4" PLATES (PROPANE FUEL)

o CHINA LAKE

- o THREE COMPOSITE PLATES, 1 ft² X 1/4" (Propane fuel)
- o THREE COMPOSITE BARREL BURN TESTS (PROPANE, JP-5 FUEL)
- o COMPOSITE SPOILERS BURN TEST (JP-5)
- o F-16 COCKPIT BURN TEST (JP-5)

Figure 22

Following those preliminary tests, eight more tests were carried out at China Lake. First three individual flat plates were burned with propane, and then a 2 foot diameter by 3 foot tall composite barrel, consisting of thin 2-ply filament wound inner and outer skins containing a Nomex honeycomb core, was burned with propane. That was followed by the burning of two half-barrels, segmented in the length direction, one first with propane, and the second with JP-5. The next test involved the burn of three 737 test spoilers at one time in a very large JP-5 pool fire. Finally, an experimental F-16 cockpit containing several types of carbon composite pieces was burned in a JP-5 pool fire.

The photograph, figure 23, of the test site at the Naval Weapons Center, China Lake, California shows why such a range was chosen. It was obviously suited for releasing fibers into the open environment without fear of affecting electrical equipment. The asphalt test pad at the left was heavily instrumented with appropriate fiber detection and measuring equipment, and the desert to the left of the pad was also instrumented for distances up to 6000 feet.

NAVAL WEAPONS CENTER TEST SITE



Figure 23

The various methods used by TRW to accumulate fiber release data is summarized in figure 24. The passive methods at the left resulted in a measure of the deposition of fibrous residues, while the active instrumentation on the right gave a time resolution of the fibers released. The sticky paper, which caught and held the falling fibers, were used as 8" x 10" sheets, 8" x 6' strips, and 8" wide rolls as long as 200 feet. The fine-meshed bridal veil fabric was used in several ways. Small cans about the size of tuna fish cans had both ends removed, and bridal veil was mounted over one end. The tuna cans were then placed vertically, normal to the direction of the air flow so that any fibers in the air flow would pass through the open end of the can and be trapped on the bridal veil. Bridal veil was also placed over 8" x 10" vugraph frames and mounted vertically, and it was even placed over 9' x 10' frames. For one particular test, a "Jacob's Ladder" 90' x 90' in size was used to suspend 342 bridal-

METHODS USED TO
DETECT, MEASURE, AND COLLECT CARBON FIBERS

<u>PASSIVE</u>	<u>ACTIVE</u>
STICKY PAPER (SHEETS, STRIPS AND ROLLS)	LIGHT EMITTING DIODES
BRIDAL VEIL OVER OPEN-END "TUNA" CANS	MICROWAVE
BRIDAL VEIL VUGRAPHS (8" X 10")	BRASS BALL DETECTORS
BRIDAL VEIL FRAMES (9' X 10')	LADAR
BRIDAL VEIL VUGRAPHS ON 90' X 90' "JACOBS LADDER"	THERMOCOUPLES (SAMPLE AND FLAME)
HAND PICKUP FROM TEST PAD	FLAME VELOCIMETER
RANGE SWEEP BRIGADE	PLUS
	PHOTOGRAPHY (INFRARED AND VISUAL)
	METEROLOGICAL EQUIPMENT

Figure 24

veil vugraphs to monitor a large cross-section of the air flow. Hand pickups by test personnel gathered burn and blast fragments from the asphalt test pad, while a "sweep brigade" of all test personnel covered the desert for up to 6000 feet after the spoiler burn test, collecting fibrous residues which had been lofted for such distances.

Of the active techniques, the first three (light emitting diodes, microwave, and brass ball detectors) monitored the passage of individual fibers, while the remainder in the list monitored the fiber and fire clouds. The principle and operation of the novel brass ball detectors has been presented in an exhibit at the rear of this hall.

The enlarged photograph of the fibers collected on the bridal veil of a tuna can collector, figure 25 illustrates the nature of the fibers given off and collected from the composite barrel burn test. The size of the mesh is approximately one millimeter, so you can see that in general, the single fibers are quite short, perhaps mostly 2-3 millimeters or less (with a few exceptions). The clustered mass of fibers in the lower right are typical of many clusters which resulted from the barrel burn test, and could probably be considered the hallmark of that particular test.

BARREL TEST 8 - TUNA CAN RECORD

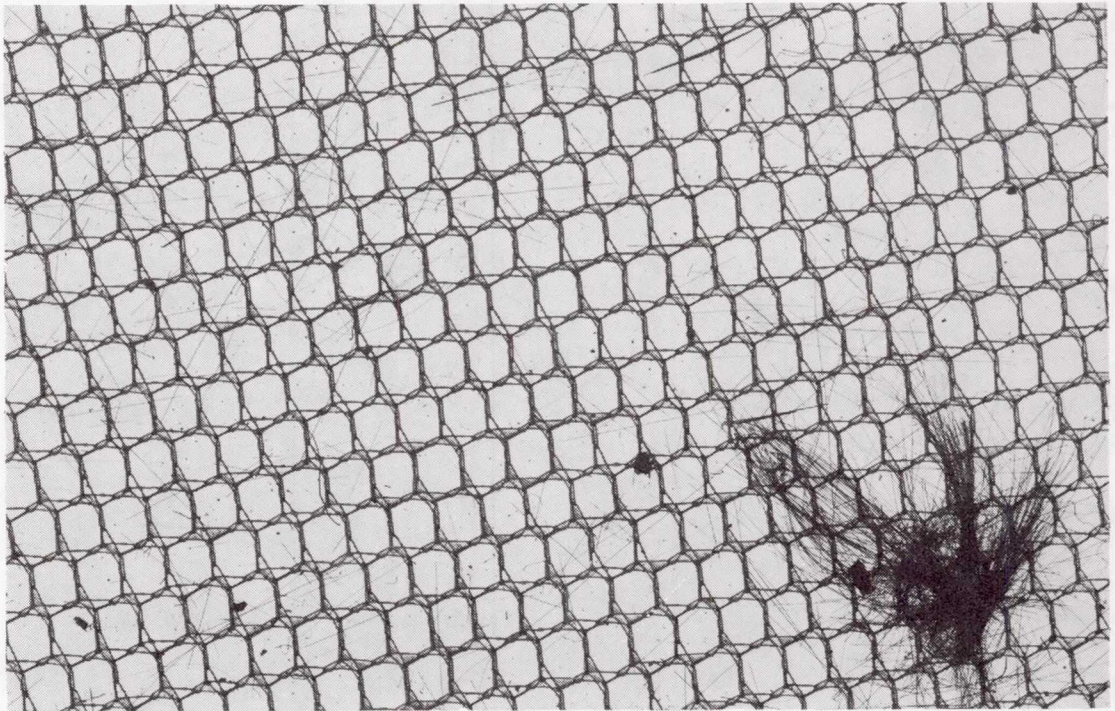

Figure 25

Figure 26 is a histogram showing the single fiber length spectrum resulting from the China Lake barrel burn test (no. 8). Once again, as has been noted for other fiber release tests, the single fibers collected on sticky paper 3000 feet from the fire were quite short, the big majority being less than about 5 millimeters.

As mentioned before, the unusual feature resulting from the burning of the composite barrel with its very thin 2-ply composite skins was the large number of clusters of individual carbon fibers. These clusters, which apparently somewhat resembled "chicken feathers", probably represented more potential numbers of fibers than the single fibers actually detected. The distribution of the cluster dimensions in figure 27 shows them to be generally from about 1/2" x 1/2" in size up to 3-4 inches on a side.

The photograph in figure 28 is of the smoke plume from the large (40 feet x 60 feet) JP-5 pool fire which was used to burn the three composite spoilers at China Lake, and it is apparent that the fire should be considered representative of a rather vigorous fuel fire which could result from an aircraft crash.

Figure 29 is a diagram of the "Jacob's Ladder" array of bridal veil vugraphs which was mentioned previously as one of the

LENGTHS OF FIBER FROM
CHINA LAKE BARREL BURN TEST

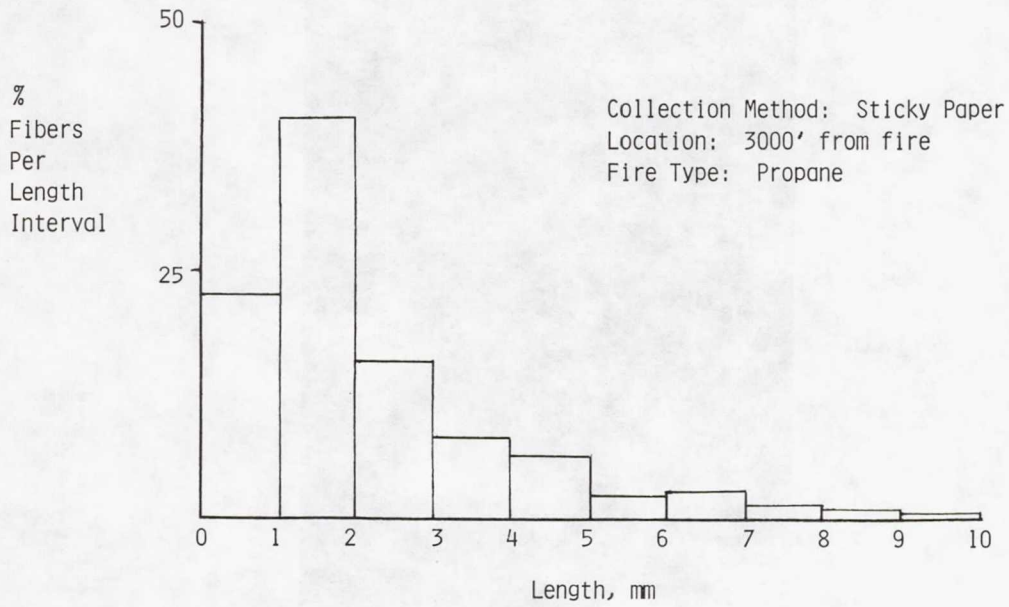

Figure 26

BARREL TEST 8 - CLUSTER DIMENSION DISTRIBUTION

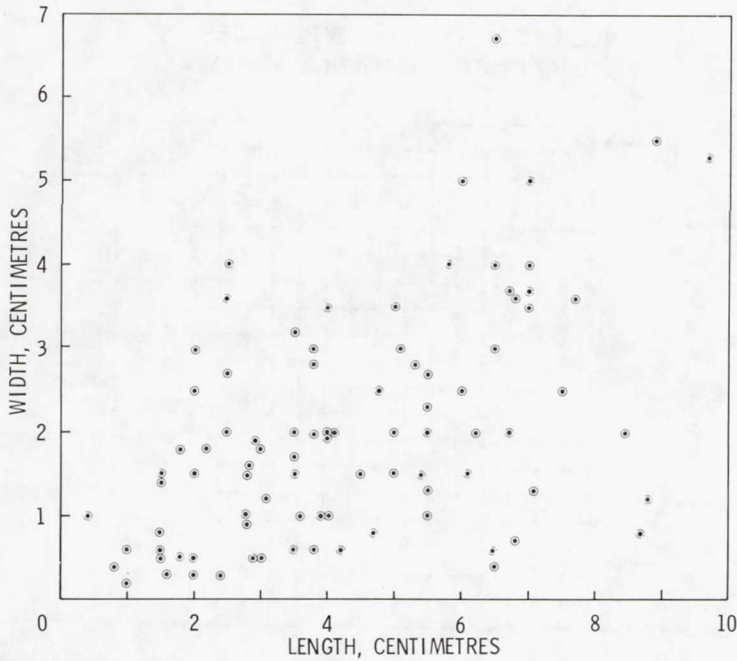

Figure 27

SMOKE PLUME FROM JP-5 FIRE

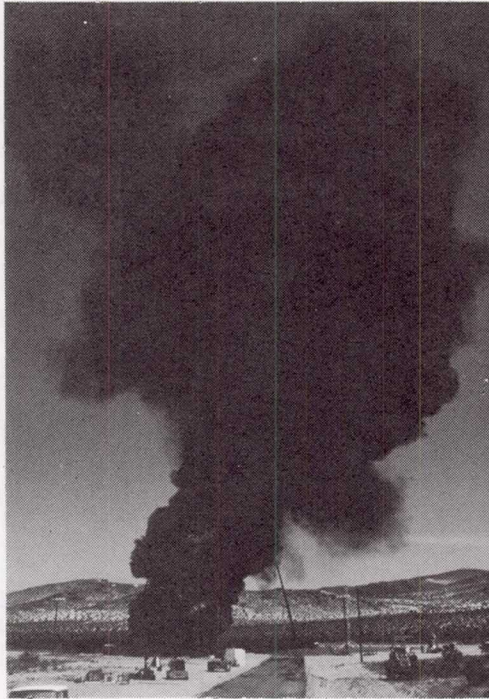

Figure 28

SPOILER TEST 11 - JACOB'S LADDER PASSIVE INSTRUMENTATION ARRAY

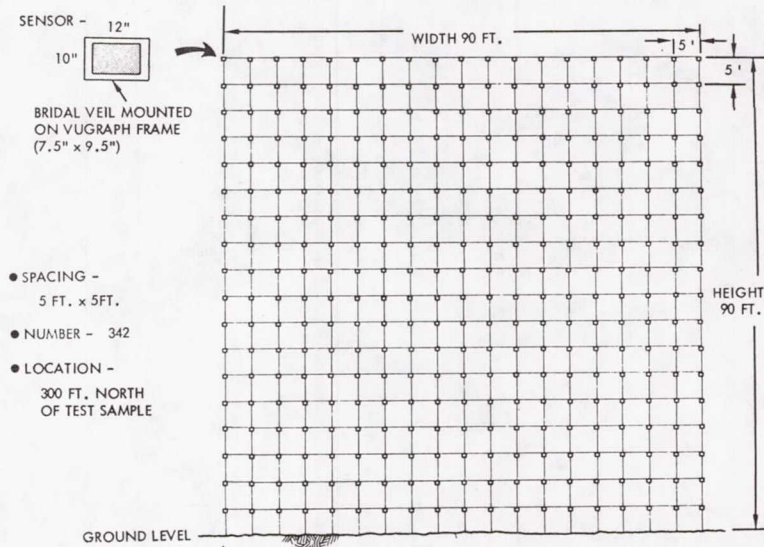

Figure 29

types of passive fiber detection methods. As noted in the figure, the vugraph frames covered with bridal veil were spaced every five feet, both horizontally and vertically. Thus, an excellent monitoring of the fiber concentration in the air is possible. In the spoiler burn test, it was found that the highest concentrations of fiber were detected by the vugraphs in the lower half of Jacob's Ladder, and up toward the upper right side of the Jacob's Ladder.

The spectrum of lengths of fibers which were collected from the spoiler burn test by bridal veil vugraphs on the Jacob's Ladder are presented in figure 30. The histogram clearly shows, as with several previously cited tests, that the majority of the fibers collected were very short, less than 4 millimeters, with a very small proportion being over 10 millimeters in length. In this case, no fibers less than 1 millimeter in length were counted, since they would have passed through the 1 millimeter mesh of the bridal veil.

LENGTHS OF FIBER COLLECTED IN
JACOB'S LADDER - CHINA LAKE SPOILER TEST

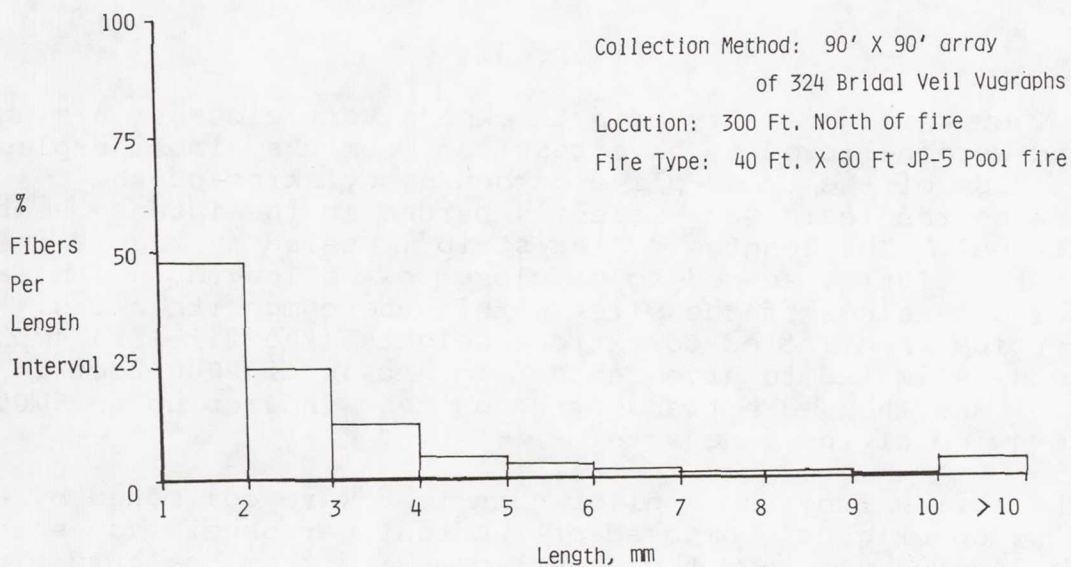

Figure 30

If the hallmark of the composite barrel burn test was the release of a large number of "chicken feather" like fiber clusters, then the unusual result of the burning of the three 737 spoilers in the large JP-5 pool fire was the release of a large number of long, narrow, thin carbon fiber strips shown in figure 31. These were collected at distances up to 6000 feet from the

SPOILER TEST 11

REPRESENTATIVE STRIP-TYPE PARTICULATE

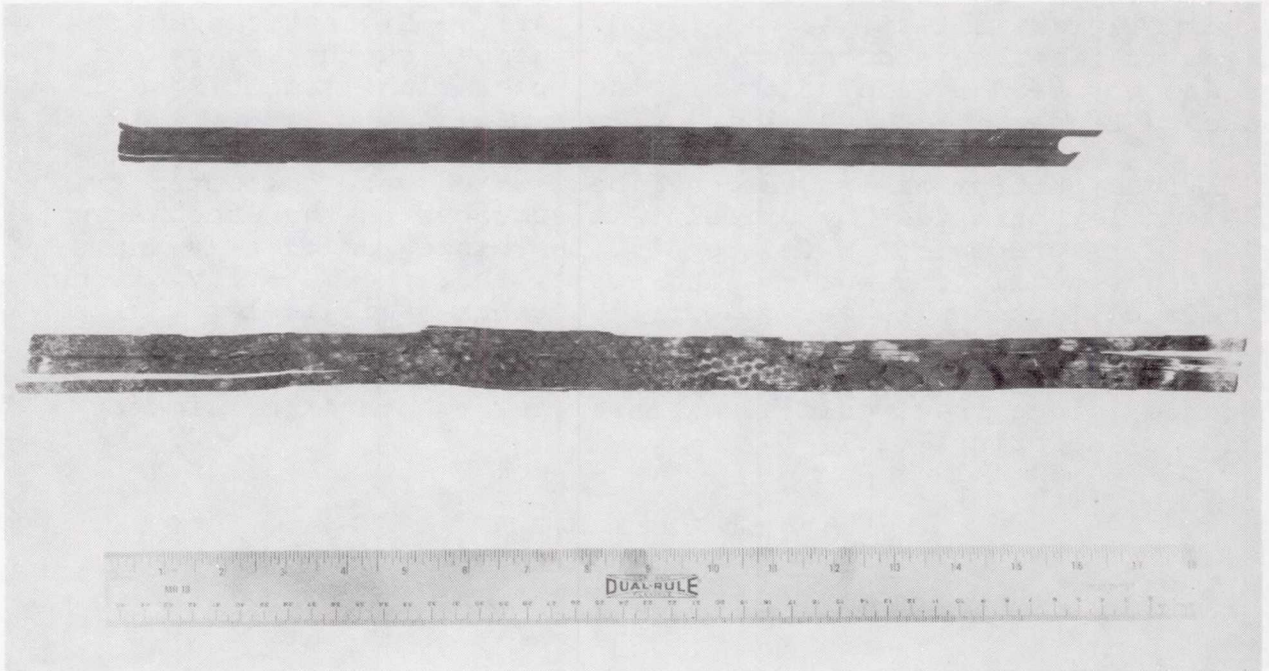

Figure 31

fire. They were generally of a thickness very close to a single ply, and were believed to have resulted from the almost explosive delamination of the cross-plyed carbon/epoxy skins of the spoilers as the resin was violently burned in the intense heat of the jet fuel. The lengths of the strips, scaled by the 18 inch rule in the figure, seemed to be close to the length, width, and diagonal dimensions of the plies within the composite skins. These strips were lofted to extreme heights (the fire and smoke plume was estimated to have reached in excess of 2000 feet in altitude) and then were transported by the wind for up to 6000 feet downwind of the fire site.

The strips from the spoiler burn test were collected by a range "sweep brigade" composed of the test personnel who, spaced at arms length, searched the desert downwind from the burn site. As they collected each strip, the size of the strip and its precise location on the desert was noted. Thus, an excellent record and thorough characterization of the strips was obtained. This unusual strip deposition spectrum shown in figure 32 describes four dimensions of the spectrum. In the foreground is noted the location of the range where the strips were found, on the left is the classification of the lengths of the strips, and the vertical scale gives the additive numbers of strips found in each length interval. And then a key to the strip width

SPOILER TEST II - STRIP DEPOSITION SPECTRUM

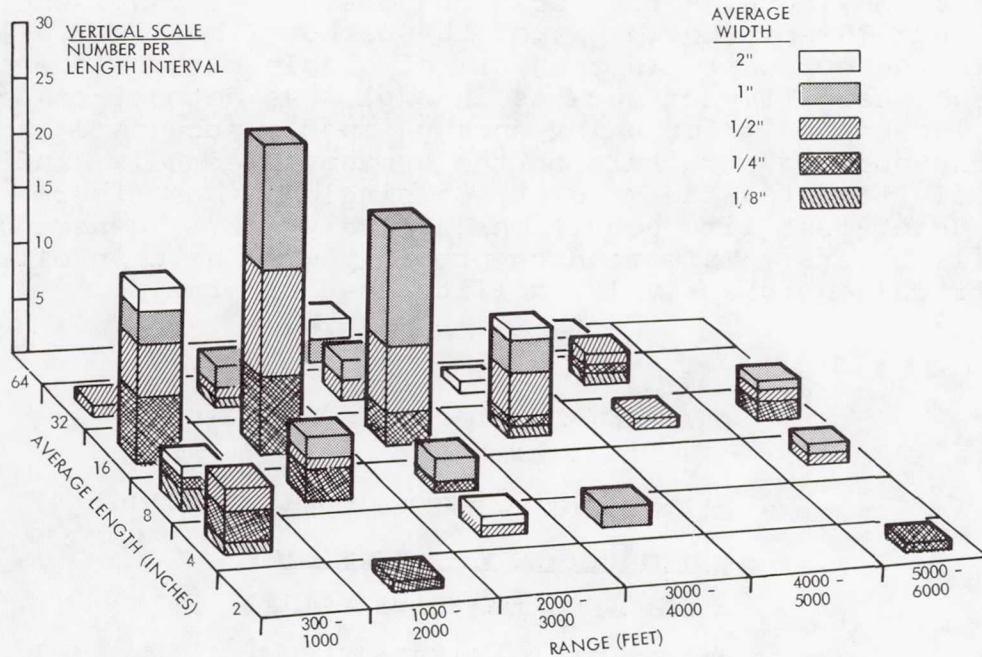

Figure 32

spectrum, from 1/8 inch to 2 inches is given in the upper right portion of the figure. Actually, a large number of strips were collected from the test pad and also at up to 500 feet from the fire site, before a record of the strip size and location was begun. Therefore, if these had been included in the pictured strip deposition spectrum, they would have increased the numbers in the left hand portion of the figure to give a more normal decrease in numbers of fibrous strips from left to right (decreasing distance from the fire).

Although there is some question as to the degree of success that was achieved in tracking the dissemination of single fibers from the China Lake tests, there is no doubt that the formation and dispersion of large numbers of clusters of fibers (as in the barrel burn) and the generation and transport of long strips of fibrous residue (from the spoiler test) created a new awareness of types of carbon fiber materials other than single fibers which could, under entirely imaginable situations, represent substantial threats to outdoor electrical equipment.

Now, it is appropriate to present a summary, a little bit quantitative but mostly qualitative, of some of the findings to date from our simulated carbon fiber release testing.

First of all, as shown in figure 33, we believe that the burning of representative aircraft parts which use relatively thin composite skins, such as the DC-10 rudders and 737 spoilers, will release about 10% of the weight of the carbon fiber initially present in the composite in the form of single carbon fibers with a very high energy impact such as an explosive detonation and probably less than 1% for a low energy impact, such as a short fall of the burning structure to the ground. Secondly, and quite conclusively to date, the majority of single carbon fibers released under most fire conditions are very short, generally less than 3 millimeters. This finding probably will have an effect on the electrical equipment vulnerability test program.

CONCLUSIONS FROM SOURCE STUDIES
(PRELIMINARY)

- BURNED AIRCRAFT PARTS(DC-10 RUDDER, 737 SPOILER) USING THIN COMPOSITES RELEASE:
 - ABOUT 10% SINGLE FIBER WITH HIGH ENERGY IMPACT
 - LESS THAN 1% SINGLE FIBER WITH LOW ENERGY IMPACT
- UNDER MOST FIRE CONDITIONS, MAJORITY OF RELEASED SINGLE FIBERS ARE VERY SHORT (< 3 mm)
- THIN CARBON COMPOSITES RELEASE SINGLE FIBERS EASIER THAN DO THICK COMPOSITES
- SUBSTANTIAL AMOUNTS OF CARBON FIBERS IN THIN COMPOSITES MAY BE OXIDIZED IN VERY HOT FIRES
- CARBON FIBERS (AS, T300) IN COMPOSITES OXIDIZED EASIER THAN "GRAPHITE" FIBERS (HMS, HTS, GY-70, ETC.)
- AGITATION OF COMPOSITE DURING OR AFTER THE FIRE IS REQUIRED TO RELEASE FREE FIBER

Figure 33

A general observation is that thin carbon composites release single fibers more readily, in general, than do thick composites; this probably comes as no surprise to anyone. Furthermore, there is strong evidence that substantial amounts of carbon fibers in thin-skin composites may be completely oxidized in very hot fires. Along these lines, it has been shown that the carbon fibers AS and T300, which at this time are most often used in aerospace composites, are oxidized in fires more readily than are those higher performance fibers such as HMS, HTS, GY-70, etc. which may have some graphitic content. And perhaps very importantly, testing to date has demonstrated most definitely that some as yet undefined amount of agitation, turbulence, or impact during or

after a fire is required to release any significant numbers of free single carbon fibers.

At this time there remain a number of uncertainties concerning the accidental release of carbon fibers from burning composites which must be resolved before reliable predictions can be made of how much fiber might be released from actual crash fires of composite-containing civilian aircraft. These uncertainties are summarized on figure 34. One uncertainty is that of just how much of the fiber in a burning composite can be completely consumed by the fire, and thus be eliminated from concern. It is planned to study this uncertainty very hard in testing in the near future. A second uncertainty lies in the amounts and sizes of single fibers which can be released from

UNCERTAINTIES OF CARBON FIBER RELEASE

- AMOUNT OF CARBON FIBER OXIDIZED IN AIRCRAFT FIRES
- AMOUNT AND SIZE OF SINGLE FIBER RELEASED FROM FIRES OF VARYING INTENSITY
- CHARACTER OF CARBON FIBER RESIDUES (SINGLES, LINT, CLUSTERS, STRIPS) RELEASED FROM FIRES OF VARYING INTENSITY
- CORRECT SIMULATION OF AGITATION AND TURBULENCE EFFECTS UPON BURNED COMPOSITE RESIDUES
- OPTIMUM TECHNIQUES OF FIRE-FIGHTING AND CONTAINMENT OF COMPOSITE RESIDUE AT ACCIDENT SITE

Figure 34

fires of varying intensity. Next, the China Lake burn tests have made us look beyond our initial prime concern with single fiber release to an equal consideration of other forms of released fibrous species, such as lint, clusters, and strips which, while not as transportable through the atmosphere to the great distances that single fibers will reach, nevertheless may pose substantial hazards to exposed outdoor high voltage power equipment. In view of the emerging criticality of turbulence and agitation to the amount of fiber which can be released from burning composites, it

is clear that a knowledge of just what form and intensities of disruption to the burned composite residues can be considered to be realistic.

The last uncertainty on the list, one which has not been mentioned until now, pertains to the need to find the optimum techniques to fight the aircraft crash fires and worthwhile methods to contain and dispose of the wreckage containing composite debris to minimize the release and spread of carbon fibers. However, an investigation of those factors is being initiated by the military services, with some NASA participation; and it is expected some important and useful information will result from that program in the near future.

QUESTIONS

Question: The question is related to the photograph showing the residues from the woven composite sample where the individual plies had come apart. Would the release of single fibers be less from woven material than from uni-directional or cross-ply material?

Response: Our feeling is that that is probably true in the absence of any very high impact. There have been tests run in the Dahlgren chamber with very high impacts and some of the results indicate quite the opposite. There are weaknesses built in the weaving operation which might tend to cause more fiber to be released. In just the burn situation, with the very low impact, it looks like the woven material is better as far as inhibiting fiber release.

Question: Was reduction in fiber diameter observed?

Response: Yes, from the numbers I've been given in both the China Lake barrel and the spoiler tests, the fibers went from an average of 6 1/2 to 7 microns in diameter down to about 4 microns which represents about a 50% reduction in the cross section of the fiber.

Question: Are we getting into a health hazard at those diameters?

Response: I don't know. I think other government agencies are looking into that matter. I think they're drawing the guidelines at around 1 micron in diameter for these particles. However there's a region between 1 and 3 microns where some people have indicated concern so it may be a consideration in the future.

Question: Question related to the minimum lengths of fibers measured.

Response: In some cases where the fibers were collected by deposition they were counted down to half millimeter in length. In other cases where they were collected with the bridal veil, they stopped at one millimeter because that was the mesh size of the veil. In many of the tests there are very small particles, almost identical with soot which must have come from the blasting of the residue. There are fine particles but we have not addressed the size of them.

Response by Dr. Sessels of TRW: In the Capistrano tests that were performed by TRW, they did analyze fibers with lengths down to 5 to 10 microns in length and the information is available.

Question: Who is the contact for the China Lake tests?

Response: Mr. Quentin Porter of Rome Air Development Center and Dr. Paul Lieberman of TRW.

Page intentionally left blank

Wolf Elber
NASA Langley Research Center

This presentation covers the technical background of the subjects of dissemination as well as redisseminations and fiber life. These subjects were defined in the overview presentation. Dissemination, as shown in figure 1, is the first release of the

OUTLINE OF PROBLEM

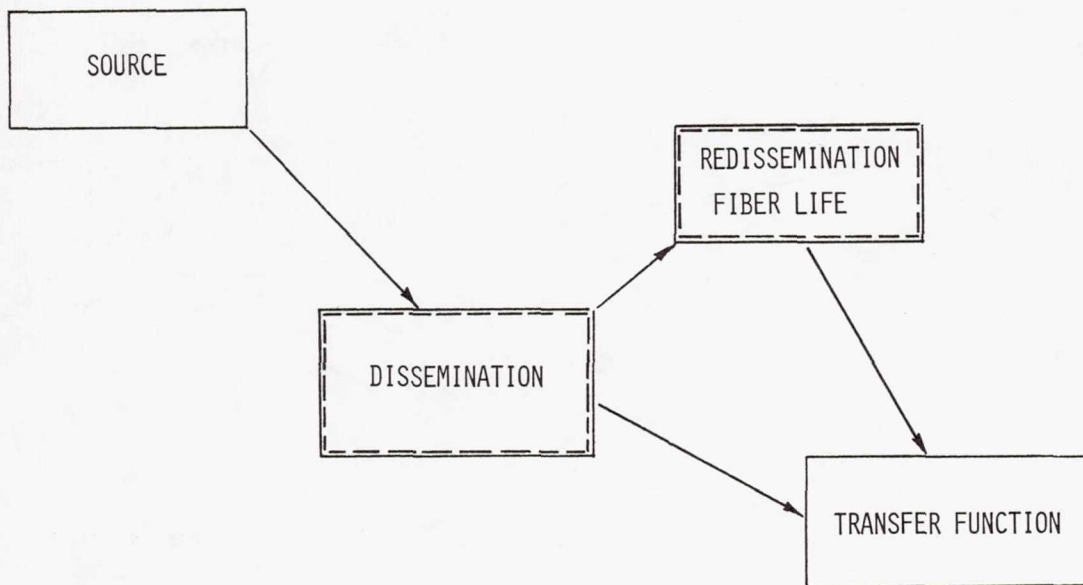

Figure 1

fiber and the drift of the fibers, or clumps, or fragments in the pollutant cloud downwind from the accident scene. Those fibers will of course deposit somewhere and there is a possibility that they are either stirred up by wind or traffic to be redisseminated. If they are not redisseminated, then they might be buried in the ground or destroyed. That's the subject of fiber life.

I want to treat first the dissemination portion of the problem and give you a basic introduction. I want to leave you with a qualitative idea of how the fibers are disseminated and some quantitative feel for the range and the amount of dissemination.

In figure 2 you see a typical accident scene. Above the aircraft accident we consider having a fire plume, which as long as

ACCIDENT SCENE

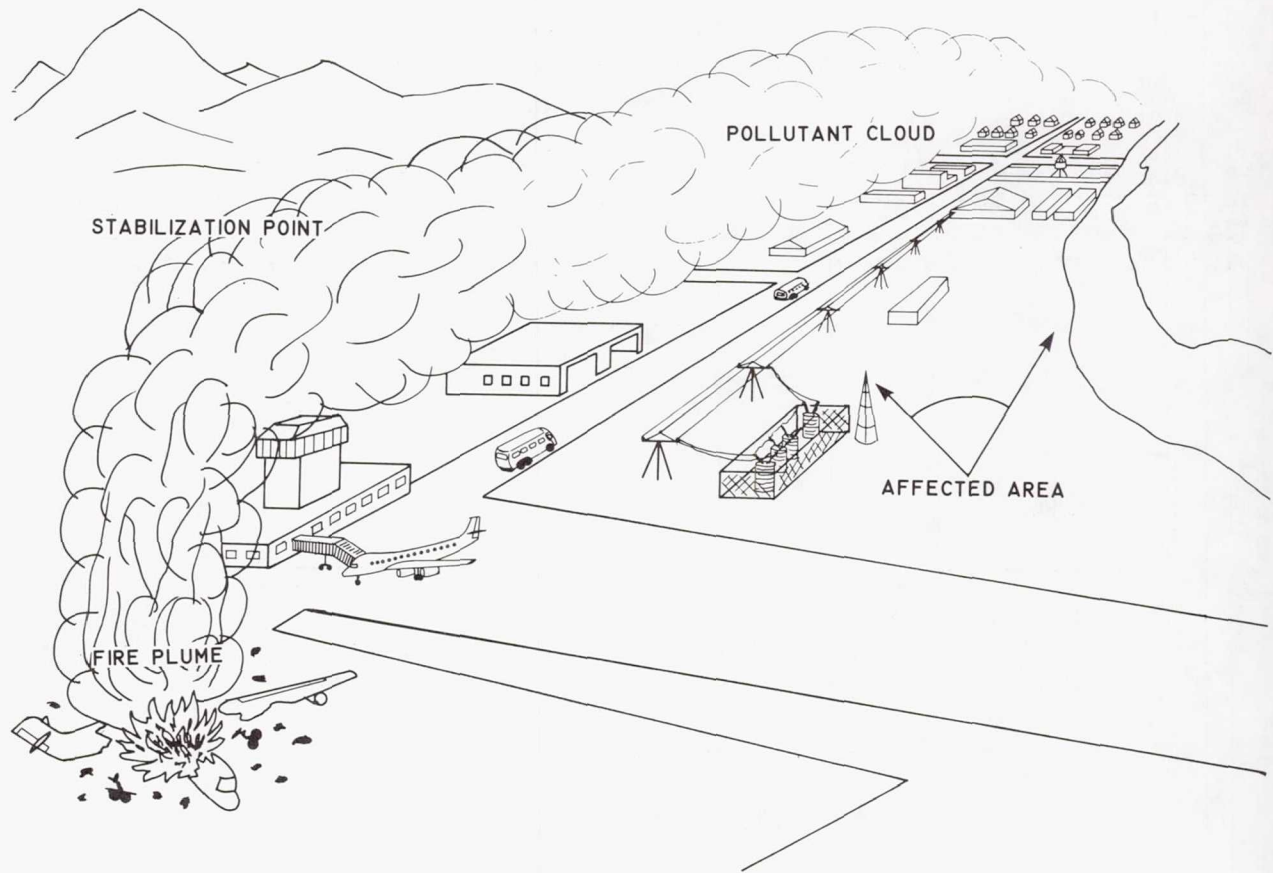
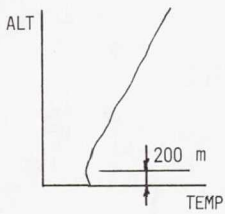

Figure 2

it has thermal energy also has buoyancy and therefore a vertical velocity. After a while it mixes with the ambient air and it will stabilize. After that we consider the next phenomenon which is the drift of the pollutant cloud downwind over industry, domestic areas, and possibly out to sea. The whole process is very strongly dependent on the weather. One of the first characteristics of a certain weather situation is the vertical temperature profile in the atmosphere, because mixing of aerosols occurs only in the convective band, i.e. below the inversion.

In this first case, in figure 3, which is typical of a nighttime situation, we have an inversion at about 200 m. So the mixing occurs over a relatively shallow layer. If there are any winds, they are typically very low, so that the cloud drifts slowly. This nighttime weather would be categorized as an E or F Pasquill-Gifford stability class. As you can see on the sketch below this first case, the moon is shining, and the plume is spreading at a relatively shallow angle that is characteristic of stable weather conditions. The spread angle is of the order of 10 degrees, sometimes even less.

PLUME SPREAD AND WEATHER



TYPICALLY: LOW WINDS
NIGHT

CATEGORY:

STABLE E

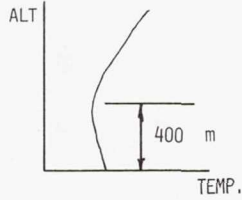
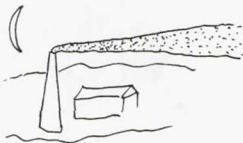

TYPICALLY HIGH WINDS

TYPICALLY OVERCAST

CATEGORY

NEUTRAL C

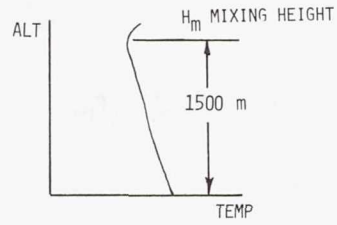
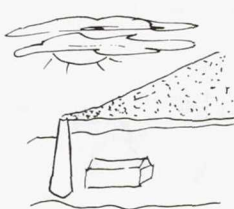

TYPICALLY SUNNY

LOW WINDS

CATEGORY

UNSTABLE A

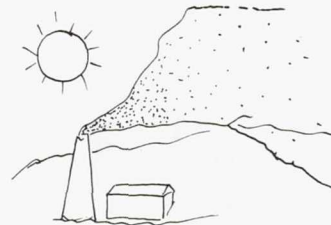

Figure 3

In the second weather situation, called a neutral weather category, we have typically very high winds, typically it is overcast and the mixing depth is very much deeper, on the order of 400 meters. The sketch shows overcast weather and a spread angle of the plume cloud on the order of 20 degrees, somewhat larger than for the stable weather. In the third category, that's the weather we all like to have, and don't often get, it's the typically sunny weather, low winds, and Pasquill-Gifford category unstable A. If ever you see cumulus clouds in the sky, you know you have unstable weather, usually B sometimes A. The mixing layer is typically more like 1500 meters. The atmosphere is mixed over very great depths and of course, that means also that the pollutants are mixed over those depths. The sketch shows the sun shining and the plume spreading at an angle of about 40 degrees. When it encounters the inversion the plume will not penetrate that inversion because there is no vertical turbulence up there. It will stay below the inversion, or reflect.

Next I want to define the measures of pollution shown in figure 4. One thing that is of course important is the concentration of the pollutant, the number of particles over the volume, or volumetric density. Usually, more important than the

MEASURES OF POLLUTION

$$1. \text{ CONCENTRATION, } C = \frac{\text{NUMBER OF PARTICLES}}{\text{VOLUME}}$$

2. EXPOSURE OR

$$\text{DOSAGE, } E = \text{CONCENTRATION X TIME}$$

$$= \int c \, dt$$

$$3. \text{ DEPOSITION, } D = \frac{\text{NUMBER OF PARTICLES}}{\text{AREA}}$$

Figure 4

concentration is the exposure, which is the concentration times the time of exposure, or the time integral of concentration. In some instances, the number of particles that get deposited on the ground, or the number of particles per unit area would be a suitable measure of pollution. Measure of pollution is not quite the same, of course, as the measure of potential damage. We have to measure the potential damage. We also need to know the area over which we get certain exposures. Therefore we plot an area-exposure diagram. For each exposure such as exposure E4, in figure 5, we calculate and plot the area A4, over which that level of exposure is exceeded. The integral $\int E \, dA$ is a significant measure of potential damage. The others are just a measure of pollution. One important point, at this time you've seen this morning that the vulnerability or the damage is a continuous proportional function of exposure, so that even at extremely low values of exposure, you still have a very small probability of failure. Now if you have a very large area, at a given small exposure, the product of that large area and exposure contains a lot of equipment and may cause just as much damage as having exposure over a small area. That is peculiar to this situation which we have - a probability of damage continually defined as a function of exposure, whereas in other pollution problems we talk about a critical value below which we're safe, above which we're unsafe.

MEASURE OF DAMAGE POTENTIAL
 AREA COVERAGE DATA

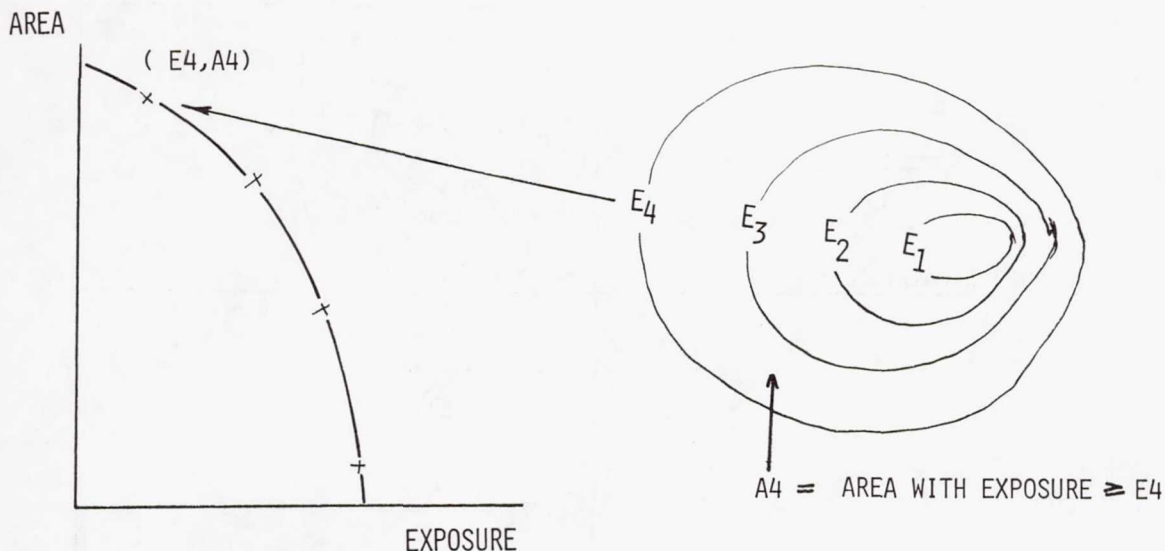

Figure 5

Many of you have seen the type of footprints that have been used in the studies of the last few years to show the range over which we can affect the countryside. Figure 6 is drawn basically to give a qualitative feel for how strong the exposure effects can be. In the top left hand figure, I've drawn an exposure profile where the outermost exposure profile represents about 5% of the maximum exposure in that area. For the weather condition which was an overcast weather or night, in other words, a stable weather situation, the exposure pattern is a very narrow streak, and it could extend the five percent level 100 kilometers from the accident scene. In the unstable, sunny weather, the dispersion is very much wider, the dilution of the pollution is much stronger so the 5% level is very much closer in. In this case I've shown it as about 50 kilometers but the area is roughly the same as in the previous case because the streak is now wider. Those cases are for single fibers with fall velocity of 0.02 meters per second. Let's look at the heavier particles. Looking at lint, which was characterized as being a group of fibers typically 20 or more, it has a fall velocity one order of magnitude larger, or 20 centimeters per second. Now, that would mean it would take approximately a half a minute to fall from the ceiling to the floor in this room, whereas a single fiber would take on the order of 300 seconds, or six minutes. Thus for the

lint, the 5% level might occur out at 10 kilometers in the overcast weather and at about half that distance in the strong sunshine with the wider exposure field.

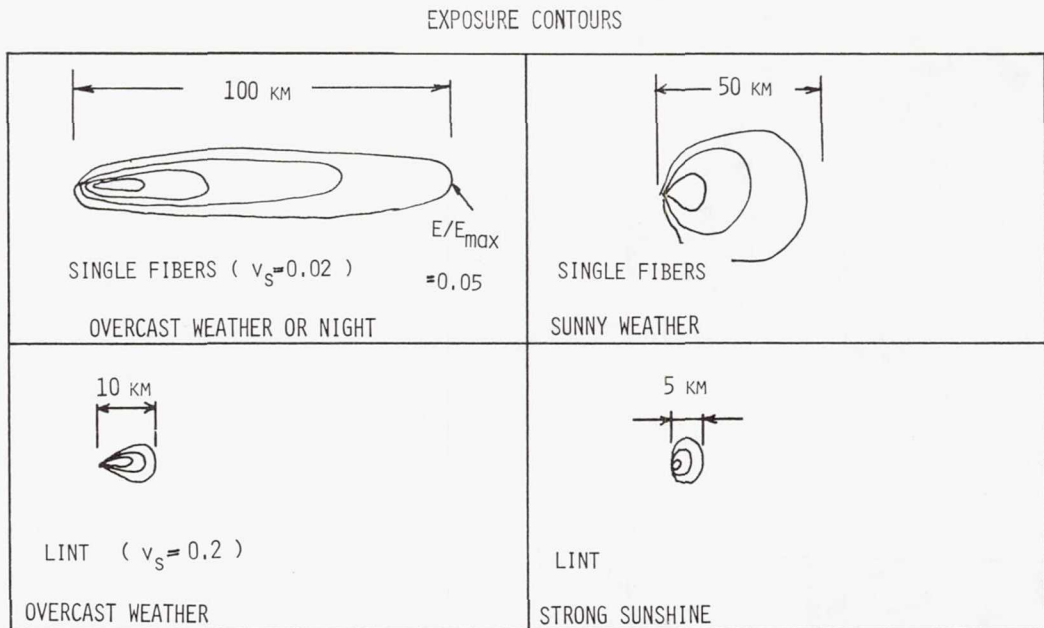

Figure 6

Figure 7 lists the parameters controlling the dissemination patterns. The fire starts the dissemination problem, and is influenced by the amount of fuel, the burning rate, the pool size, and maybe some other factors, like the pool shape, or the number of individual pools of fuel. The exposure levels of course are controlled very strongly by the source, that is, how many fibers do we get out, what length fibers do we get out and what fragments do we get out? We want to characterize those by distribution of size and fall velocity. The weather strongly influences the dissemination pattern. The effect of the vertical stability conditions and mixing layer depths has been discussed. The wind velocity influences how far the material drifts down range in a given time, and fibers can be precipitated with rain or snow. Figure 8 shows the logic for two fire plume model types: empirical models and physical models. The first model is the empirical model which consists basically of the Briggs' equations. Those equations are based on observations of smoke stacks and provide reliable answers for the stabilization height and location.

PARAMETERS CONTROLLING DISSEMINATION PATTERNS

FIRE: AMOUNT OF FUEL
 BURNING RATE
 POOL SIZE

SOURCE: AMOUNT OF LOFTABLE DEBRIS
 SIZE AND FALL VELOCITY OF PARTICLES

WEATHER: CATEGORY: STABLE, NEUTRAL, UNSTABLE
 WIND VELOCITY
 MIXING LAYER DEPTH
 PRECIPITATION

Figure 7

FIRE PLUME MODELS

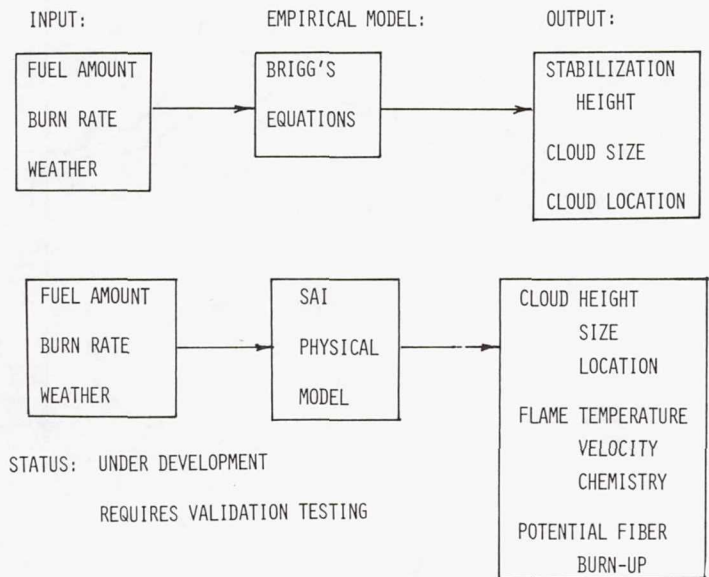

Figure 8

The growth of a fire plume is somewhat different from a smoke stack, so that an empirical expression was derived for the type of fire of interest. In most cases the fire plume will grow at an angle of approximately 40 degrees, as shown in Figure 9, so that the cloud location and stabilization height can be obtained from the Briggs equations, the cloud size from the 40 degree estimate. The second type of models are the physical models. Some work was done under contract to develop a model which takes the input conditions - fuel amount, burn rate, and weather - to obtain a physical representation of a fire including cloud height, size, location, flame temperature, flame velocity, flame chemistry, and the potential fiber burn up, which may be of importance. Some preliminary flame velocity data from this model are presented in figure 10 showing flame velocities up to about 15 meters per second. For the two fires shown here, a 7.5 meter pool and a 30 meter pool, you see that as a function of nondimensional radius from the center at a height 5 meters above the ground, both fires have about the same peak, but the little pool has already developed a more uniform plume shape. Another output from that type of model is the temperature distribution inside those fires, shown in figure 11. We see some results that were

FIRE PLUME CHARACTERISTICS

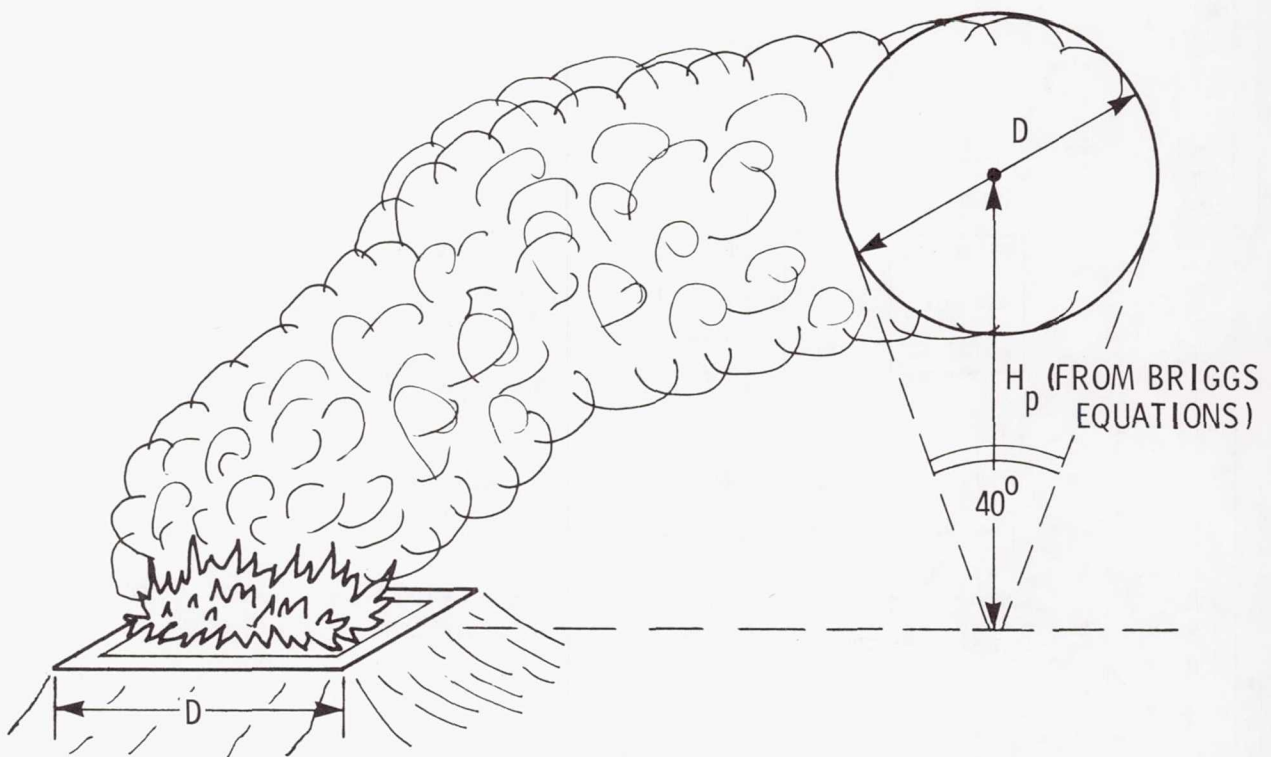

Figure 9

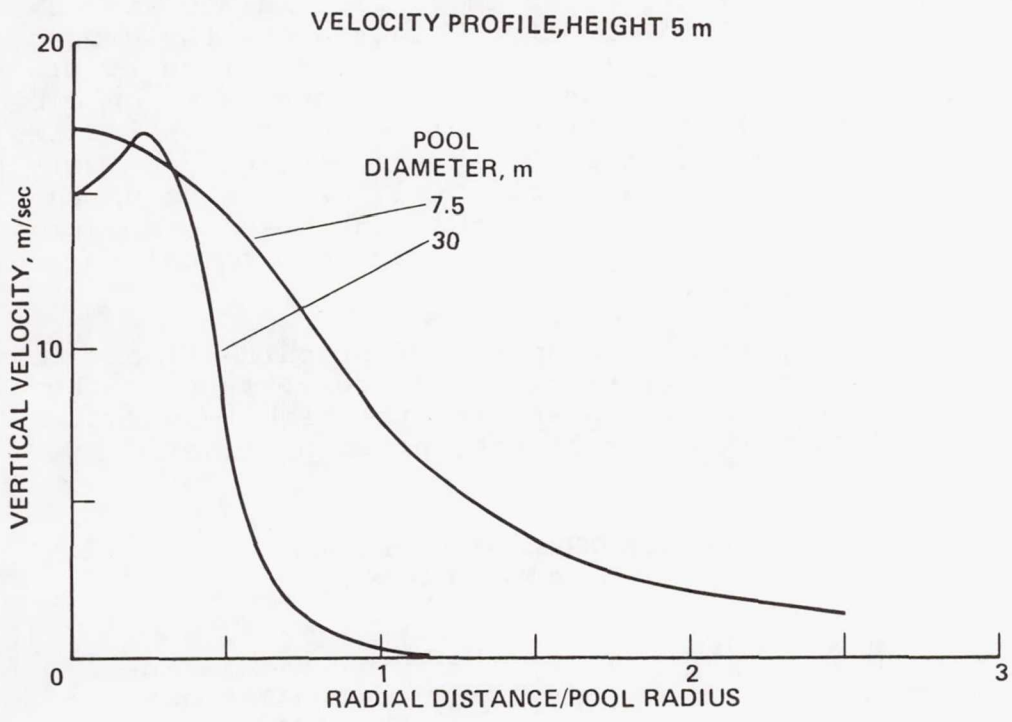

Figure 10

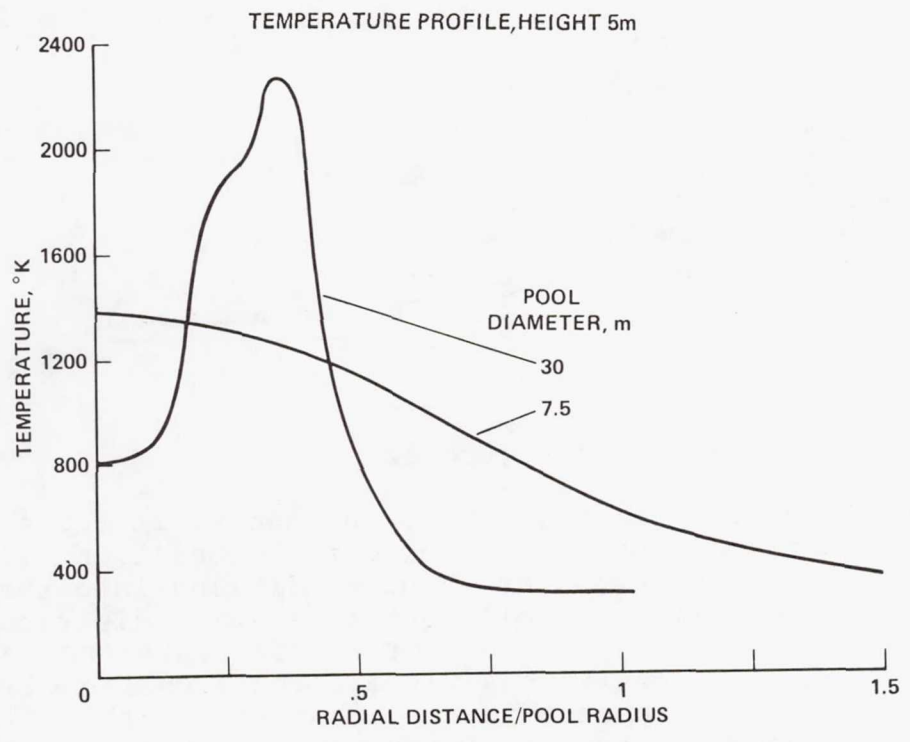

Figure 11

surprising and that were referred to earlier in a question. You see for a small pool at the 5 meter height above the ground, the temperatures are relatively low - the peak temperatures are about 1500 Kelvin which is in the range of temperatures we have been talking about. But for the large pool, we have temperatures of approximately 2300 Kelvin or 2000 degrees centigrade - very high temperatures with a very great potential for burning up the fiber. In this fire the influx of oxygen around the base is so strong that stoichiometric conditions exist, and very good oxidation and very high temperatures result.

A typical analysis of the amount of graphite fibers consumed in a fire showed that a relatively small percentage of the fibers is lost (figure 12). Other cases like the high temperature fire of course would consume a larger percentage of fiber.

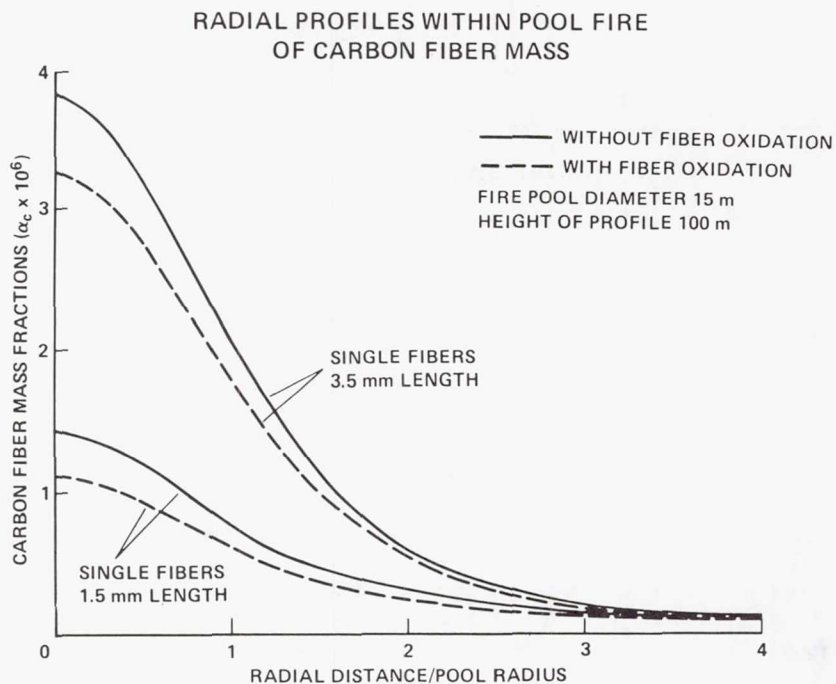
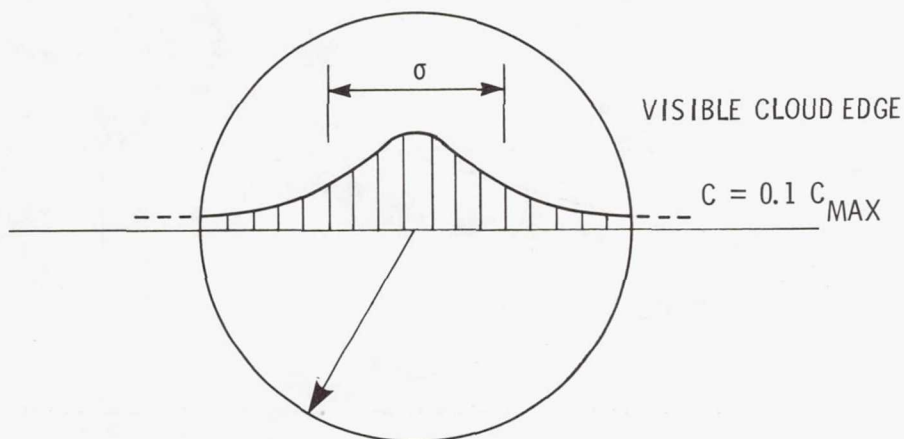

Figure 12

As the fire plume rises, mixes, and cools, it reaches a stabilization point. At that point the output conditions from the plume models are transferred as input conditions into the dissemination model. Normally the pollutant is assumed distributed in a Gaussian manner, either spherical for a short duration source or two-dimensional for a continuous plume. The Gaussian distribution has a minus R square exponent term so that we get the bell shaped distribution around the center of the cloud as shown in figure 13. That distribution shape and the size of the cloud go into the

THE GAUSSIAN CLOUD



$$C = \frac{N}{(2\pi)^{3/2} \sigma^3} e^{-\frac{r^2}{2\sigma^2}}$$

Figure 13

dissemination models. Basically, there are two types of dissemination models, the Gaussian models and the particle-in-the-cell models. In the Gaussian models, we assume that this initial Gaussian cloud drifts downwind and grows so that the standard deviation (the sigma terms) keep growing in two or three directions as the cloud drifts downwind. If the cloud strikes the inversion level, as it does in figure 14, the material in the cloud is reflected back. Some fairly complex programming steps have to be taken to reflect the material back in the computations. There are several of these Gaussian models, such as the Tretheway and Cramer models, and of course, the EPA Turner models, which are being developed for pollution problems. The dispersion coefficient, namely, the angle at which the cloud spreads, has been determined empirically for the various Pasquill-Gifford stability classes, so that you have a 10 degree cone for the stable weather and you have a 40 degree cone for the unstable weather. They are somewhat difficult to adapt to complex terrains and wind profiles. The Gaussian models are very cheap to run; a single analysis on a large computer requires fractions of a second for any one dispersion case. We use them in various forms in our risk assessment contracts. The other model type, indicated in figure 15, the particle-in-a-cell model, takes little particles in a cell and by brute force solves the 3-D diffusion equations

DISSEMINATION MODELS

GAUSSIAN MODELS
DISPERSION ALONG CONICAL SECTOR (TRETHERWAY-CRAMER , EPA-TURNER)

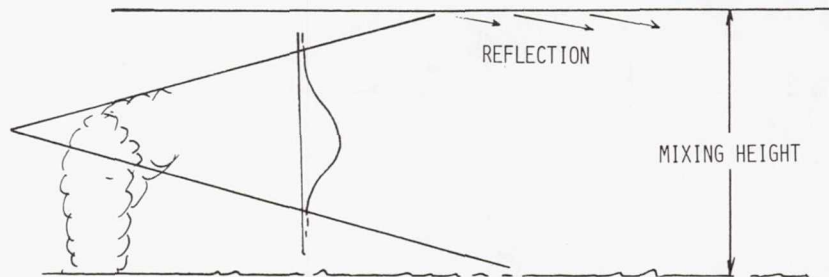

- o DISPERSION COEFFS DETERMINED EMPIRICALLY FOR PASQUILL-GIFFORD STABILITY CLASSES
- o DIFFICULT TO ADAPT TO COMPLEX TERRAINS, WIND PROFILES
- o CHEAP TO RUN
- o USED IN RISK ASSESSMENT CONTRACTS

Figure 14

DISSEMINATION MODELS (CONT.)

PARTICLE-IN-CELL MODELS (LAWRENCE LIVERMORE LABORATORIES)
SOLUTION OF 3-D DIFFUSION EQUATIONS

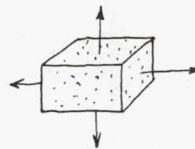

- o BASED ON DIFFUSIVITIES DETERMINED EMPIRICALLY FOR PASQUILL-GIFFORD STABILITY CLASSES.
- o TERRAIN, WIND PROFILE AND OTHER SECONDARY DETAILS INCLUDED IN BOUNDARY CONDITIONS
- o EXPENSIVE TO RUN
- o NECESSARY FOR SPECIFIC CASE STUDIES

Figure 15

including of course the fall velocity of the particles. Depending on the required precision it is a very lengthy computation. The diffusion is based on the same input data as used for the Gaussian models. The diffusivities are back calculated from the smoke plume model. In those models it is easy to adapt to a terrain for a certain wind profile and any other secondary details. Now that is important, because sometimes a cloud drifts a hundred kilometers downwind over a long time including changes in wind speed and direction as well as changes in the inversion height. These models are extremely expensive to run on computers, but to do a specific test run such as tracking a specific accident, requires the use of those models to get the precise details of where the material went.

A parametric dissemination analysis was developed to get a quantitative feel for the size of the dissemination pattern. This analysis is shown in figure 16 in a nondimensionalized form where the distance away from the source is divided by the mixing height. The fall angle (β) is the fall velocity of the particle divided by the wind speed, (N) is the number of particles and (α) is a horizontal spread angle in which all the material is contained uniformly. The exposure equation (shown) contains the source terms, proportional to the number of fibers and their fall velocity data, as an exponential term. The denominator has the weather factor term $UH^2\alpha$, which is the product of the inversion

PARAMETRIC MODEL PREDICTIONS

PARAMETERS:	$\zeta = \frac{R}{H}$	NONDIMENSIONAL DOWNWIND RANGE
	$\beta = \frac{v_s}{u}$	NONDIMENSIONAL PARTICLE FALL RATE
	$N =$	NUMBER OF PARTICLES IN THE CLOUD
	$\alpha =$	HORIZONTAL CLOUD SPREAD ANGLE

DOSAGE EXPOSURE PROFILE:

$$E = \frac{N}{uH^2\alpha} \times \frac{1}{\zeta} \times e^{-\beta\zeta}$$

DEPOSITION PROFILE:

$$D = N \left\{ 1 - e^{-\beta\zeta} \right\}$$

Figure 16

height squares, the spread angle, and the wind velocity. Such is the influence of the weather on the exposure pattern.

The second equation is for the deposition profile. Out to the nondimensional distance ρ you have a deposition fraction given by that equation. The weather factor, $UH^2\alpha$, as listed in figure 17, in the stable weather is about 3×10^4 ; in neutral weather, 5×10^5 ; in unstable weather, 4×10^6 , indicating that the exposures decreased by an order of magnitude everytime you go towards the sunny weather. Sunny weather gives you 1/100th of the local exposure values of the stable weather - the night-time conditions.

Figure 18 represents an almost scaled drawing of the dissemination pattern. Let's take single fibers with a 2 centimeter per second fall velocity and the wind at 2 meters per second and a mixing depth of 1000 meters. Only 60% of the fibers are deposited within the first 100 kilometers of the source; the others are still airborne. To drift down 100 kilometers, the cloud takes 14 hours. In that time of course, weather is going to change. You're not likely to have 100 kilometers of one weather system and even if you do, its going to change in 14 hours. Even if you were to have that stability, 40% of the particles would still be airborne, covering a wide sector of the countryside. For a case like that we can calculate the area coverage for the simple model. Once we have exposure,

THE WEATHER FACTOR

STABLE	NEUTRAL	UNSTABLE
TYPICAL:		
H : 200 M	400	1500
α : 0.2	0.4	0.8
U : 4 M/S	8	2
$UH^2\alpha$: 3.2×10^4	5.1×10^5	4×10^6

Figure 17

SCALE OF DISSEMINATION

FOR SINGLE FIBERS $V_s = 0.02 \text{ m/s}$

IN A WIND $U = 2 \text{ m/s}$

WITH A MIXING DEPTH $H = 1000 \text{ m}$

60% OF FIBERS ARE DEPOSITED WITHIN 100 KM OF THE SOURCE

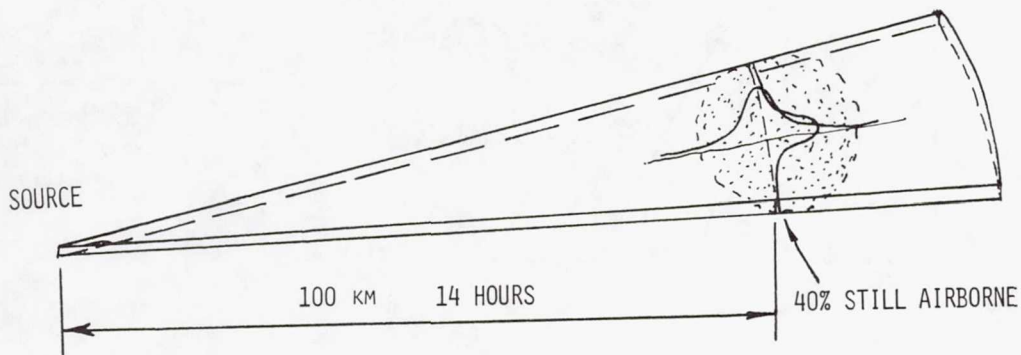

Figure 18

we can calculate the area over which that exposure occurred. We have three curves, the stable, the neutral and the unstable weather situation plotted in figure 19. You see that the stable weather situation has the high values of exposure but over a small area, whereas the unstable weather covers the extremely large areas with the lower values of exposure. Surprisingly, the total integral, which we're very interested in for vulnerability calculations, is the same for all three. We can take those data and plot the exposure and the area in nondimensional form - exposure times the weather factor, divided by N , versus a nondimensional area term. Some Tretheway-Cramer calculations for three situations - unstable, neutral and stable-fell just about precisely on that predicted relationship for single fibers. Their prediction for lint fell just about precisely on our predictions for lint as shown on figure 20. This parametric representation for small fall velocity says that the exposure falls off as the reciprocal of the distance. This guides our thinking on how the exposure profiles vary.

We've got some interesting field data for some heavy particles in the fire test at China Lake. We actually recorded the coordinates of all the strips that we found as shown in figure 21. For the purpose of this exercise, I categorized them within certain sections of range. Figure 22 shows the number of strips

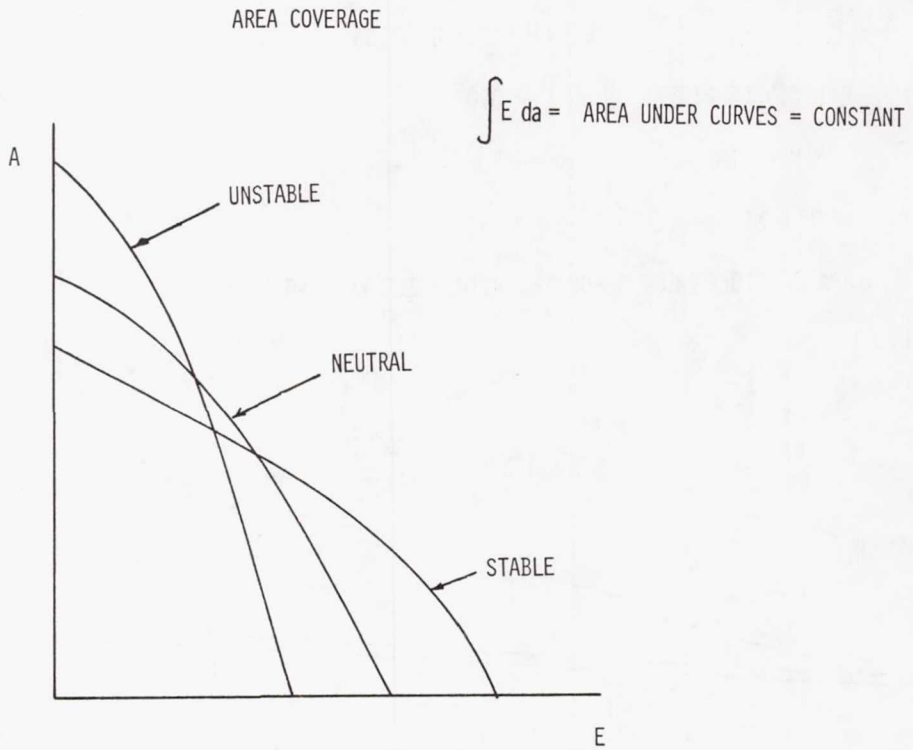

Figure 19

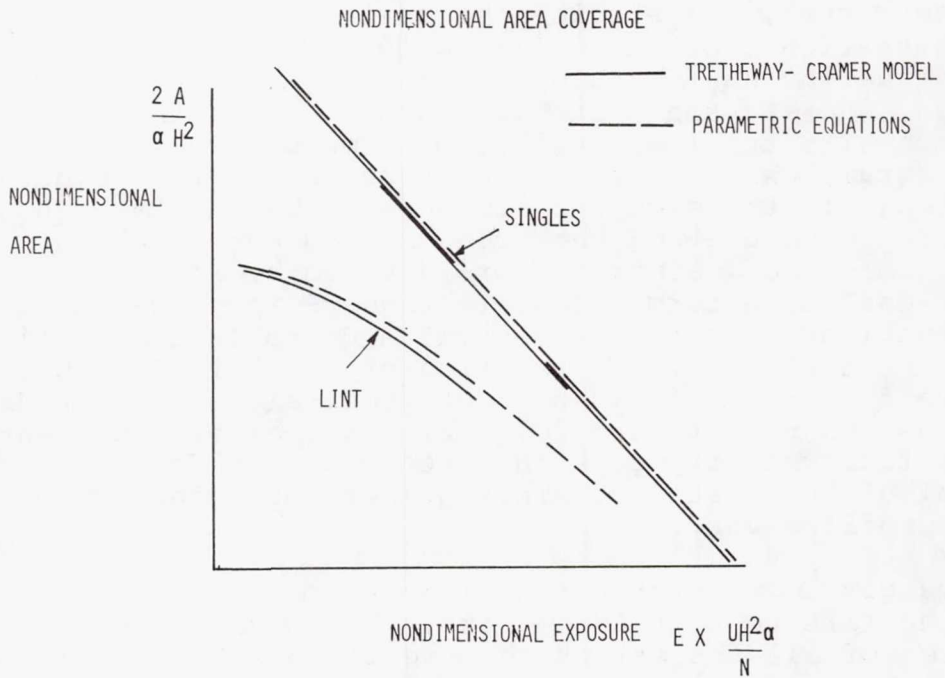

Figure 20

within each interval, as well as the cumulative deposition within each interval. Assuming a wind velocity of about 5 m/s, a fall velocity of about 5 m/s (because they were very heavy fragments), an average mixing depth at that time of 700 meters, and 130 particles, we can plot both the data and the equation for the deposition. At least in this case we see in figure 23 that the exponential profile of total deposition as a function of range is approximately valid.

Last, I want to calculate the pollution effects for a possible scenario. Assume a source of 1000 kilograms - a metric ton of composites on an airplane. If we were to destroy that airplane in a fire, we could assume 5% would be released as singles, 5% would be lint, 20% airborne fragments, and 70% residue on the ground, as listed in figure 24. From the mass of any one of those fragments, we know the number of particles for each one of those fragments per kilogram of material, we know the total particles of each category and we know their fall velocities. Now we want to calculate the exposure patterns from that source. First of all let us take the data for the singles, and we find that in stable weather, an area of approximately 1 city block will be covered at an exposure of about 10^5 particles, as shown in figure 25. Whereas in unstable weather, that same area would be covered at an exposure of about 10^4 . In the unstable case, for an exposure of 10^1 , an area equivalent to a full state would be covered, whereas in the stable case, for that value of exposure, an area of

SPOILER TEST 11 - STRIP DEPOSITION LOCATIONS

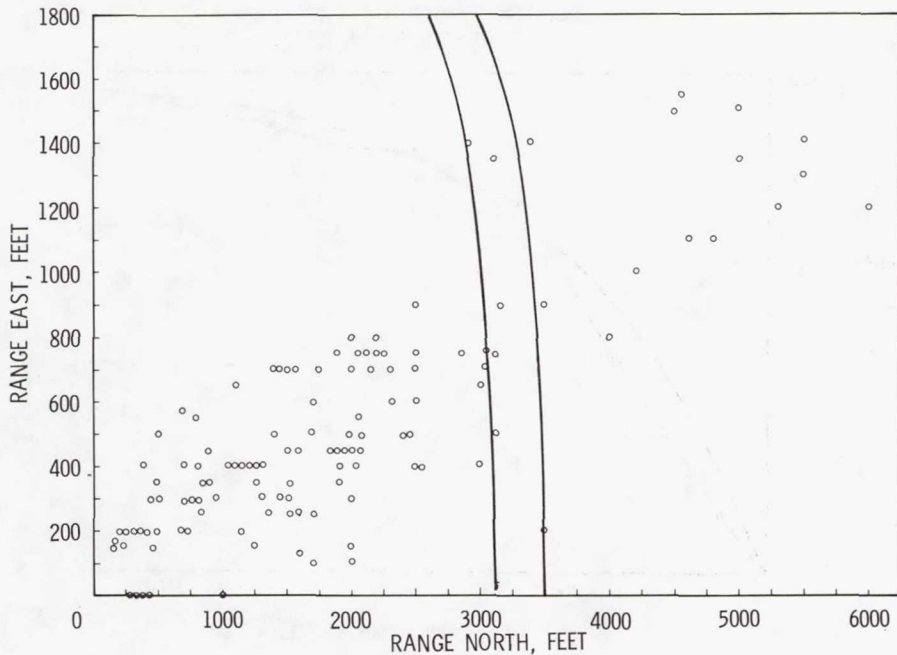

Figure 21

TEST II - CUMULATIVE DEPOSITION

INTERVAL	DEPOSITION IN INTERVAL	CUMULATIVE DEPOSITION
0 - 500	17	17
500 - 1000	16	33
1000 - 1500	22	55
1500 - 2000	22	77
2000 - 2500	19	96
2500 - 3000	5	101
3000 - 3500	9	110
3500 - 4000	1	111
4000 - 4500	2	113
4500 - 5000	5	118
5000 - 5500	3	121
5500 - 6000	1	122

Figure 22

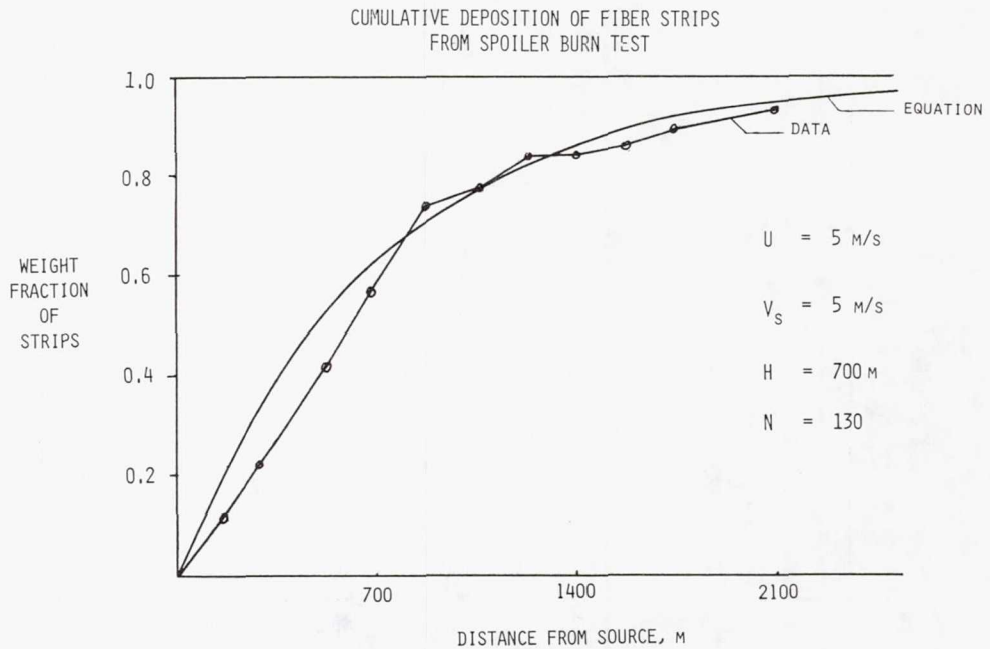

Figure 23

RELEASE AND DISSEMINATION EXAMPLE

ASSUME SOURCE: 1000 KG OF COMPOSITE

	%	MASS	PARTICLES / KG	TOTAL PAR- TICLES, N	V_s
SINGLES	5	50	10^9	5×10^{10}	0.02 m/s
LINT	5	50	10^6	5×10^7	0.2 m/s
FRAGMENTS	20	200	10^3	2×10^5	2 m/s
RESIDUE	70	700			

Figure 24

RELEASE AND DISSEMINATION EXAMPLE
AREA COVERAGE - SINGLES

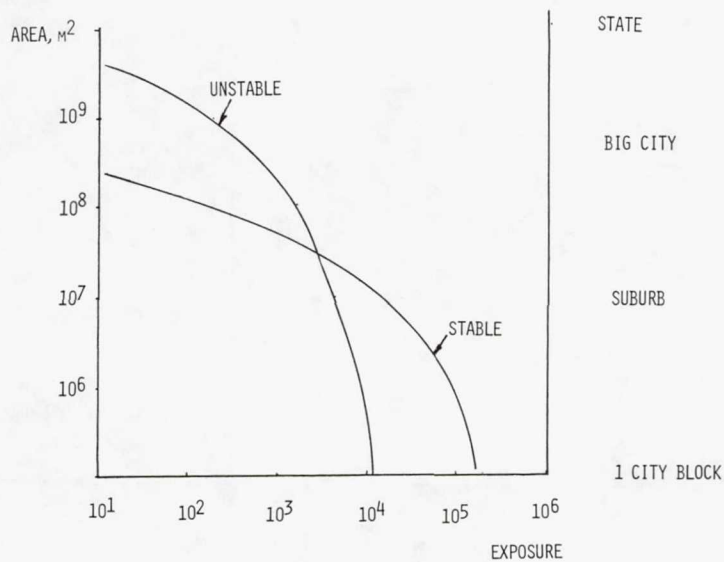

Figure 25

a big city could be covered. That is the range of exposure from this metric ton release of composite. Let's look now at the other fractions in figure 26, and instead of calculating what exposure levels occur, since we don't know vulnerability in terms of exposure for those fractions, I plotted the deposition density. For the lint, we have 5 times 10^7 particles released. In the stable case, at about 1 kilometer out, we have 50 particles per square meter deposition density, and in the unstable case approximately an order of magnitude less. For the fragments at 500 meters out we have about 0.4 particles per square meter, and in the unstable case, again, significantly less. Those data are not used in the risk assessment because we haven't qualified the vulnerability of equipment to that type of particle.

In summary, as listed in figure 27, we know the following about dissemination. We have the simple fire plume models available. The differences between all of them affect only the short range immediately around the fire. We have the complex fire plume models under development, they will be most useful to use in determining the oxidation potential of the fibers. We have cloud dissemination models available; we have the simple Gaussian models, which we're using in the very many repetitive runs that we need to do for a risk assessment, and we have the complex models which we could use if we ever needed them for specific tracing of an event. We have the parametric analysis which gives us a little more quantitative insight into the

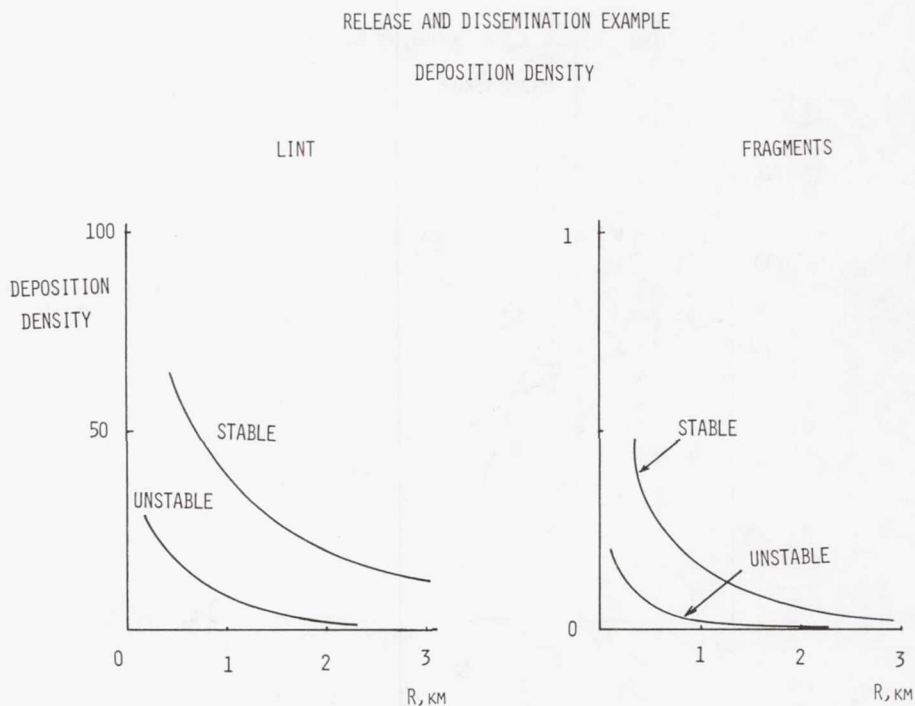

Figure 26

SUMMARY FOR DISSEMINATION MODELS

- . SIMPLE PLUME MODELS AVAILABLE
 - . DIFFERENCES AFFECT SHORT RANGE ONLY
- . COMPLEX PLUME MODELS UNDER DEVELOPMENT
 - . PREDICT TEMPERATURES, OXIDATION POTENTIAL
- . CLOUD DISSEMINATION MODELS AVAILABLE
 - . SIMPLE, SUITABLE FOR REPETITIVE APPLICATIONS
- . PARAMETRIC ANALYSIS SHOWS THAT AREA COVERAGE IS INSENSITIVE TO UNCERTAINTIES IN MODELS
- . SUFFICIENT TEST DATA AVAILABLE TO VALIDATE DISSEMINATION MODELS

Figure 27

interrelations between the very many parameters involved. But it also shows that the total area coverage, which we're using as a measure of our damage potential, is rather insensitive to a lot of parameters that go into the fire plume model and into the dissemination model. We now feel that we have sufficient test data to validate our dissemination models to the levels of accuracy that we required for this study.

I will talk about fiber life and redissemination as outlined in figure 28. I want to talk about outdoor testing, the program direction that we have in mind, and a brief summary. In a study done in the desert in which we checked on the redissemination of some fibers that had been deposited there, we could get a measure of the significance of the redissemination of the single fibers. The data that we plot in figure 29 are the vertical deposition, which means the tuna can catch, over a 24 hour period, as a function of the time after the deposition, since June 75 to the present. After a very high initial peak the deposition falls to very low levels. Integration shows that by now, 1% of that source has been redissemination. The other data in figure 30 show that the fibers initially had a 8 mm mean length but as time went on the type of fibers collected became shorter and shorter, so that by now, three years after the event, the average fiber length

REDISSEMINATION

- DESERT STUDY SHOWS SOME REDISSEMINATION OFF HARD-PAN SURFACE
 - REDISSEMINATION RATE DECREASES WITH TIME
 - FIBER LENGTH DECREASES WITH TIME
- REDISSEMINATION FROM VEGETATED LAND INSIGNIFICANT
- SUBJECT UNDER CONTINUED STUDY

Figure 28

VERTICAL DEPOSITION OF FIBERS AS A FUNCTION OF TIME

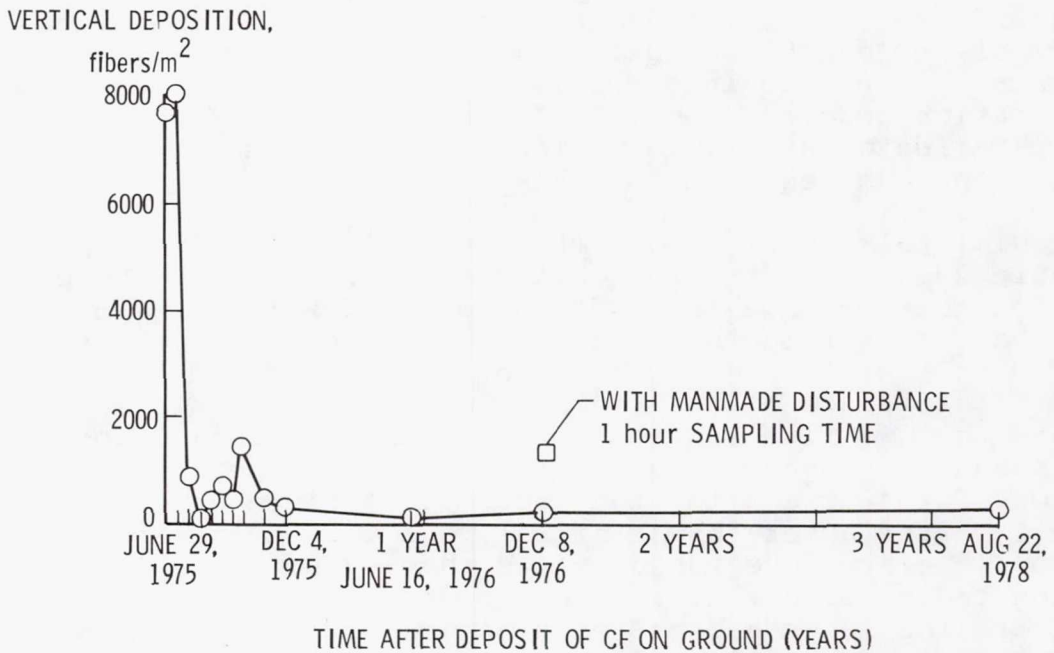

Figure 29

MEASURED AVERAGE LENGTH OF FIBERS AS A FUNCTION OF TIME

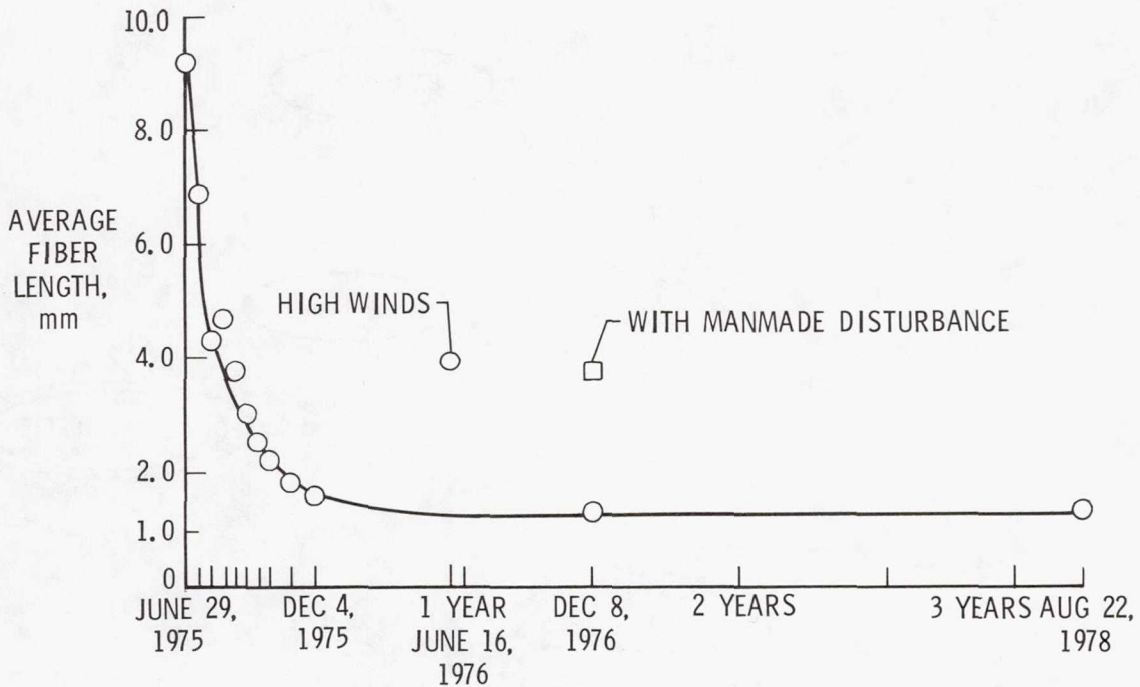
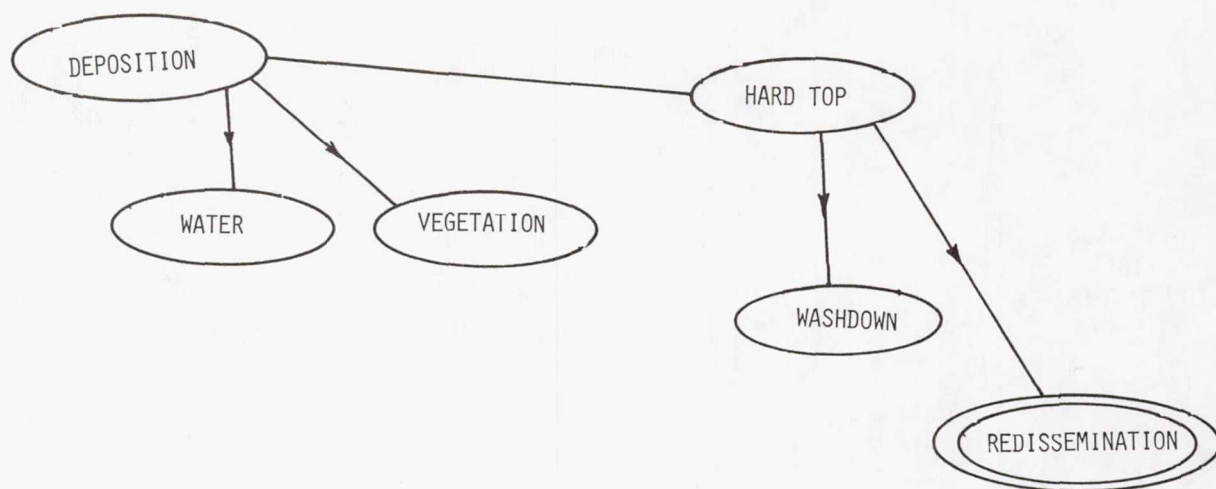

Figure 30

collected is approximately 1 millimeter. The residual fibers are caked into the desert crust. Some of them stick out, and the only time any of those fibers are released is when saltating particles rolling along the ground strike pieces of graphite off the clumps that are lying there. That's the mode that we currently feel is in operation out there, and the reason for the shorter fibers. The conclusion is, that the dissemination rate decreases with time, and the fiber lengths decrease with time, or to be more precise, the spectrum of size has its maximum at a shorter length. The desert country out there can be classified as hard pan surface which has a very short roughness length that makes it possible for the singles to be picked up. In a vegetated country, like even short grass, agricultural lands, or forests, it would be impossible to redisseminate singles back out of those depths because the boundary layer is so thick and laminar. Therefore, we feel that we won't get much redissemination from anything except a hard surface. That subject of course is under contained study.

Let me show you on figure 31 the road map for what we have in mind. This is the problem for single fibers. Starting with the deposition, they can fall into water, vegetation, or they can fall on hard top. On the first two, those fibers must be considered as dead, the resuspension rates are very very small. From

REDISSEMINATION OF SINGLE FIBERS



- SMALL FRACTION FROM SMALL AREA.

Figure 31

the hard top, which might be typical of a city area, concrete, asphalt, roofs, much of it could be washed down into the drainage system of a large city. The rest might be available for redeposition. But on the whole, the amount available for redeposition represents a small fraction from a very small area. Let's look at the larger fragments in figure 32, where we just calculated a deposition density. Those fibers could again be deposited in water, where they would be immediately lost. In vegetation, with deep vegetation forests, they would be lost. The big particles however are going to sit on top of shallow vegetation, like lawns. They could essentially be fragmented by wind action or other disturbances. They could land on the hard top where some could be lost to washdown. We could clean up the area and get rid of some of them once and for all. Traffic could fragment those remaining particles providing a source of single particles. Now that would remain the main study issue, because the large clumps and fragments contain most of the mass of the debris and could act as a substantial source of singles. However, again you're looking at the possibility of resuspending from only a very small area.

In conclusion, we need to continue working this issue of redeposition, but are relatively confident with the other

REDISSEMINATION FROM CLUMPS AND FRAGMENTS

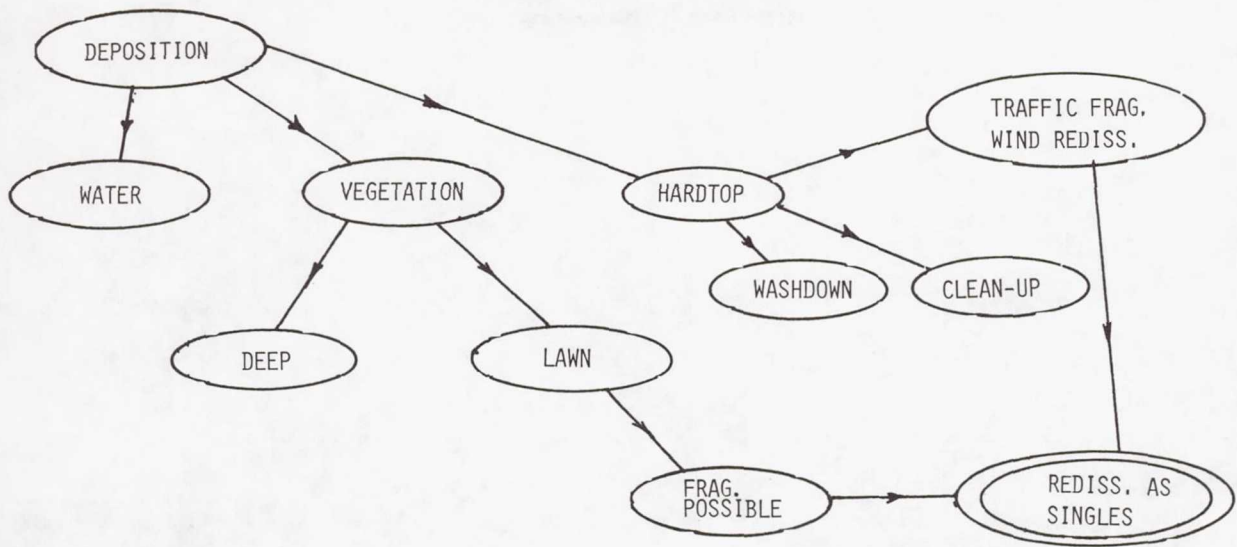

● MAIN STUDY ISSUE

Figure 32

models of dissemination and the fire plume models. We are working on advanced models to get oxidation state.

Question: How did you test the parametric model?

Response: I took the strip data set from the spoiler burn test and analyzed the deposition, and found that it was an exponential distribution.

Page intentionally left blank

TRANSFER FUNCTIONS

Israel Taback

The Bionetics Corporation

There are various interfaces, such as filters, doors, window screens, and cabinets, which affect the concentration, exposure, or deposition on the two sides of an interface. The dimensionless ratio of these quantities as they challenge and breach the interface is called the transfer function.

Before transfer functions are discussed, it is useful to review the overall problem of doing a vulnerability assessment. I will talk in general about single fiber lengths, but when overall vulnerability assessment is done, we must remember that the fibers released from the source are of various lengths and, in general, would have a distribution as illustrated in figure 1. It is believed that the shorter ones will be numerous and the longer ones relatively infrequent. This would be designated as a source characteristic. At a specific location away from the source, that distribution can very well change, depending upon how those various fibers fly, the fall rates, and perhaps some of the fiber lift char-

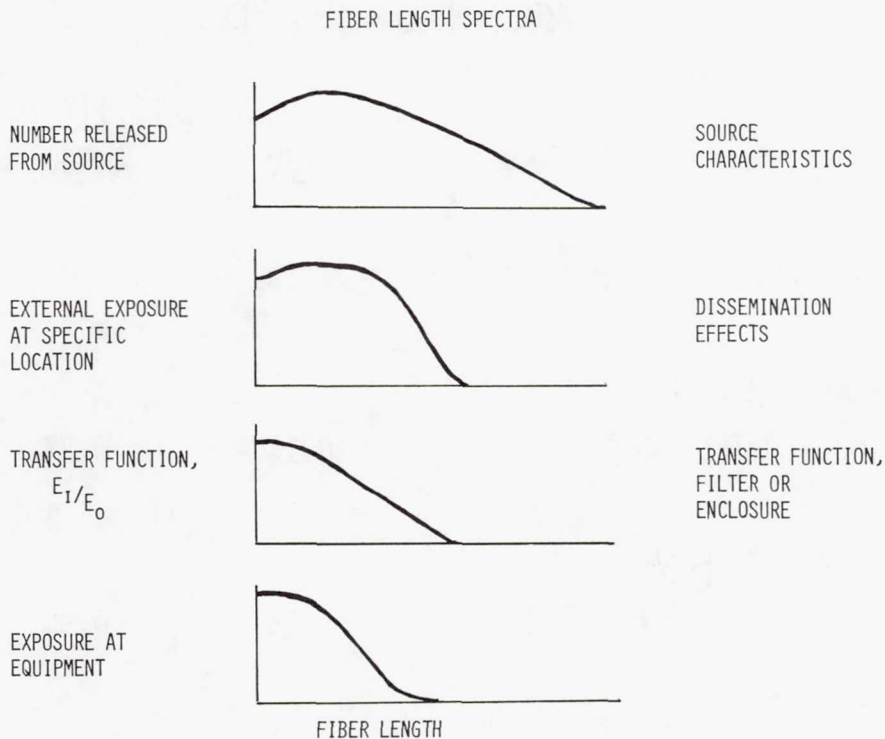

Figure 1

acteristics. The phenomena would be included in dissemination effects. We then get to the external exposure outside a piece of equipment. The transfer functions between the external and internal world must be evaluated, and we find that the transfer functions for the shorter particles are larger than the transfer functions for the larger ones. To get the exposure for a piece of equipment, all of these factors are evaluated at a fixed fiber length. The installed vulnerability of the specific equipment is evaluated by determining its local exposure at a fixed length and then integrating its vulnerability over the complete length spectrum.

Figure 2 illustrates a number of typical values for filter transfer functions. This work was done with fibers about 7 millimeters in length. These are a limited number of samples, there are more in the literature. The first one illustrated is one that is used quite often in ground support equipment. It is a multi-layer aluminum mesh called Air Maze (trade name), tested dry. In its normal mode, this material is used coated with a sticky liquid. We tested it dry in order to get some idea of what would happen if the filter were poorly maintained. The figure illustrates the transfer function at a velocity of 100 feet per minute, which is approximately the velocity at which the filter is used.

FILTER TRANSMISSION
(MEDIUM LENGTH FIBERS)

	AIR VELOCITY IN FEET/MIN		
	<u>100</u>	<u>400</u>	<u>800</u>
MULTI LAYER ALUMINUM MESH, AIR MAZE R-82, UNCOATED (DRY)	1%	2%	4%
MULTI LAYER ALUMINUM MESH, AIR MAZE R-82, COATED (WET)	0.1%	0.2%	0.5%
3/8-INCH-THICK OPEN FOAM POLYURETHANE	0.1%	0.9%	1.4%
WINDOW SCREEN	1%	10%	15%

Figure 2

Transmissivity factors of the order of 1% may occur, and as the air velocity through that filter is increased, we find that the percentage passed through that filter also increases. These tests were done at 100, 400, and 800 feet per minute. When this same filter is coated, which is the condition in which it is normally used, it has transmissivity of the order of tenths of a percent at all velocities. Its transmissivity is still a function of air velocity. Another commonly used filter is open foam polyurethane. This filter was 3/8-inch-thick open foam. Again the transmissivities ranged from about a tenth of a percent to 1.4 percent. We also tested one very interesting interface, a window screen, which is not normally regarded as a filter.

At air velocities of about 100 feet per minute (which is about a mile an hour), it had a transmissivity of 1% and then rose very rapidly at higher speeds to about 10 to 15%. One other filter was tested with material of rather long lengths, compared to the lengths of the fibers just discussed. It is another piece of polyurethane filter, and the results are shown on figure 3. It has a trade name, Scott Foam, and is 3/4" thick. It did not react the way the other filters did in terms of its response to various air velocities.

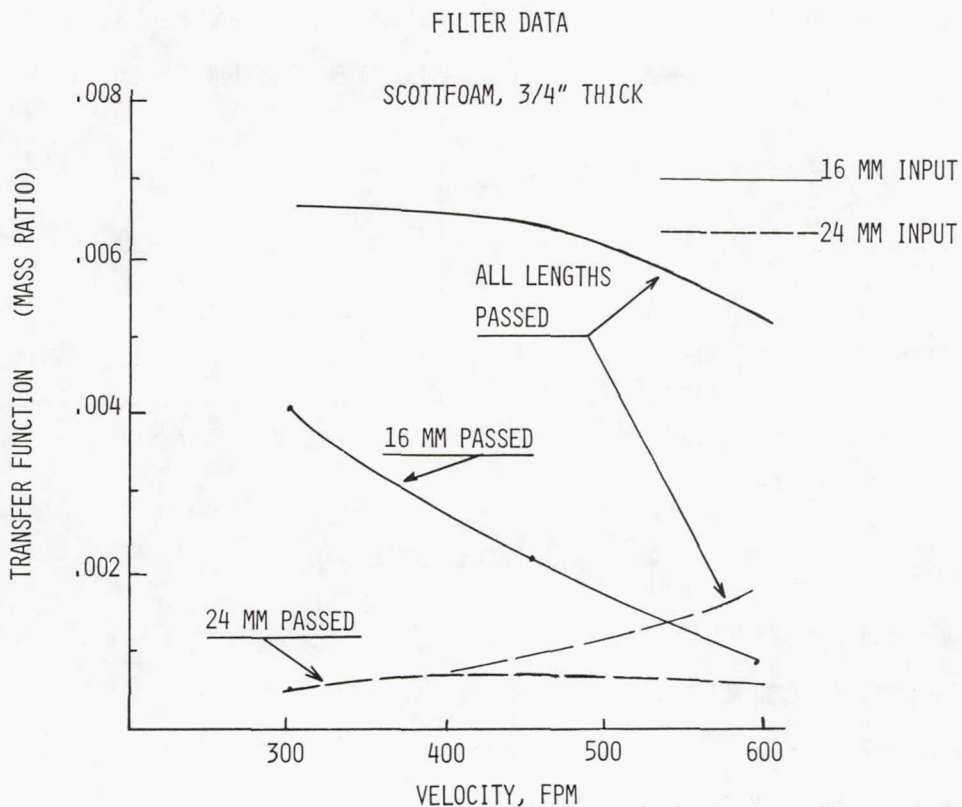
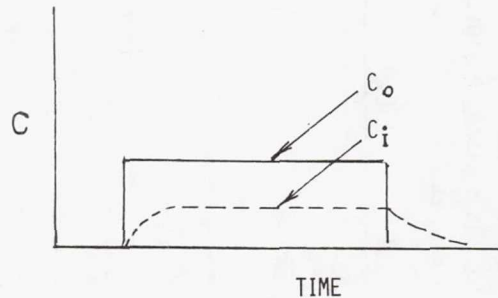
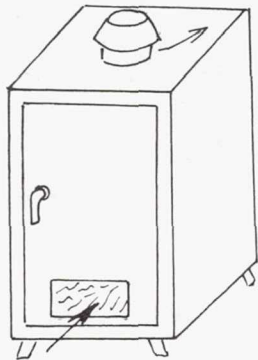

Figure 3

When the 16-millimeter material was passed through the filter, the amount of 16-millimeter material which came through the filter varied with air velocity from about 0.004 (note this is not percent, this is in mass ratio) to a value about 0.001 at high velocity. On the other hand, if you look at the mass transfer ratio without regard to the length of the material passed (the upper solid line), this was relatively invariant with velocity through the filter and, in fact, decreased as the velocity through the filter increased. The ratio of all lengths passed was about 2 to 3 times the amount of material that was passed at the 16-millimeter length. Very much smaller ratios were secured for the 24-millimeter material, and again there was a difference between the total amount of material passed, regardless of length and the material that was passed at the original length. These numbers, by the way, seem to be somewhat typical of most of the filters that we have tried. A transfer function of approximately a few tenths of one percent seems to be a number that we come across many times.

One typical enclosure, sketched on figure 4, that we encountered in some of our survey work was evaluated for its overall transfer function. This is a rather typical traffic control box somewhat similar to the kind that exist on many street corners. It contains electronic equipment which controls traffic signals. That equipment not only controls the traffic signals, but also has

TRAFFIC CONTROL ENCLOSURE TRANSFER FUNCTION



VOLUME, $V = 1 \text{ METER}^3$
 FLOOR AREA, $A = 2/3 \text{ METER}^2$
 FLOW RATE, $Q = 1/30 \text{ METER}^3/\text{SEC}$
 FILTER T.F., $F = .002$
 FIBER SETTLING VELOCITY, $V_s = .02 \text{ M/S}$

STEADY STATE:

$$\text{T.F.} \cdot C = \frac{C_i}{C_o} = \frac{F}{\left[1 + \frac{V_s A}{Q}\right]} = .0014$$

$$\frac{\int C_i \, DT}{\int C_o \, DT} = \text{T.F.} = .0014$$

Figure 4

within itself a conflict sensor, such that in the event of an electric fault, it will put all the lights on that corner onto red. One electronic failure in this box, generally, is not of large concern with regard to causing accidents. The volume of this box is about one cubic meter, and the floor area is $2/3$ of a square meter. The enclosure is ventilated by a flow into the box of about a 30th of a cubic meter per second, so that it takes about 30 seconds to ventilate the entire box.

We have tested the specific filter that is used in these boxes, at least in the city of Newport News, and find that these filters have a transfer function of about 0.002. The fibers that were considered here are single fibers, and their fall velocity is of the order of about 0.02 meters per second. If one hypothesizes that there is a square pulse of concentration outside the box and looks at the inside of the box, the concentration inside the box comes up slowly with time and reaches a steady-state value.

At the end of the pulse, the concentration drops off at a rate that is shown in the figure consistent with the ventilation rate of the box. If the internal concentration is computed with respect to the external, it turns out to be a function of the filter factor divided by one plus a correction term. This term consists of the fall velocity times the area of the box divided by the flow rate into the box. This fall rate, this settling term as it is called, is the settling that would occur if the internal mixing in the box was fairly uniform so that the concentration throughout the box was constant.

The overall-steady state transfer function for concentration turns out to be 0.0014, somewhat smaller than the filter function of 0.002. The transfer function for exposure is the ratio of the integrals for concentration with time. For the external exposure, the integral takes the form of a square pulse. For the internal exposure the integration must include the effect of buildup and the effect of drop-off. In performing the integration, the two effects balance, and the transfer function for exposure is exactly the same number as computed for the steady-state ratio of concentrations.

There is one interesting thing about this filter, as well as all others. (I'll present this in inches and you can turn it into meters). If the height of that filter were about 6 inches and there was a little bit of a gap at the top of the filter (which we have observed in many installations) of perhaps an eighth of an inch, one would find that perhaps ten times as many fibers entered that box due to the poor installation of the filters. The most important factor with regard to the number of fibers that may be ingested into this box may not be the filter itself but how well it is inserted into its holder.

The next illustration, figure 5, is for a typical room. It is hard to recognize in meters but it is a 9- by 12-foot room with an 8-foot ceiling. The infiltration factor which I have assumed is 0.1. The flow rate into the room is such that the ventilation time for the room would be of the order of about 3 hours. That is fairly realistic. It could be as little as 2 and as large as 6 depending on how well built the house was. We assumed that the room has an air conditioner with a filter having a transfer function of 0.005 with a flow rate such that it could ventilate the room in about 8.6 minutes.

The equation in the upper right of the figure gives the same relationship that was shown in the previous figure; that is, the ratio of the internal to the external concentration. Again, the integral is really the same ratio that would be secured in the steady state (if indeed the pulse lasted long enough to achieve steady state). The ratio is always correct regardless of the length of the pulse.

Again, we find that the predominate factors that determine the ratio of internal to external transfer function consist of the filter factor, the filter infiltration factor, and three terms in the denominator: the settling velocity times the area of the room, the filter factor of the air conditioner and its flow rate, and both divided

TYPICAL ROOM TRANSFER FUNCTIONS

<p>ROOM DATA</p> <p>V VOLUME = 23.3 M³</p> <p>A FLOOR AREA = 9.72 M²</p> <p>F_I INFILTRATION T.F. = 0.1</p> <p>Q_I FLOW RATE = .0022 M³/SEC</p> <p>VENTILATION TIME = 3 HRS</p>	<p>AIR CONDITIONER RECIRCULATING:</p> $\frac{\int C_i DT}{\int C_o DT} = \frac{F}{1 + \frac{V_s A + (1 - F_{AC}) Q_{AC}}{Q_i}}$ $= \frac{0.1}{1 + \frac{.19 + .045}{.0022}} = 10^{-3}$
<p>AIR CONDITIONER DATA</p> <p>F_{AC} AIR CONDITIONER T.F. = .005</p> <p>Q_{AC} FLOW RATE = .04 M³/SEC</p> <p>VENTILATION TIME = 8.6 MINS.</p> <p>V_S FIBER SETTLING VELOC. = .02 M/S</p>	<p>AIR CONDITIONER INTAKE:</p> $\frac{\int C_i DT}{\int C_o DT} = \frac{Q_i F_i + Q_{AC} F_{AC}}{Q_i + Q_{AC} + V_s A}$ $= \frac{2.2 \times 10^{-4} + 2.2 \times 10^{-4}}{.0022 + .047 + .19} = 2 \times 10^{-3}$

Figure 5

by the infiltration volume flow. There are really only two important terms here; one is the filter infiltration factor, and the second is the fall rate of the fiber. The characteristics of the air conditioner, as such, do not strongly affect the ratio of internal to external exposure. That ratio, the room transfer function, turns out to be about 10^{-3} . One can recompute this with the air conditioner bringing in air from the outside.

We still have an infiltration factor which is assumed to be the same, although it may change somewhat with the air conditioner running. The input-flow volume of the air conditioner and its filter factor appear, and when that is evaluated, it turns out that the fact that the air conditioner is taking in air and passing it through its filter has only raised the internal to external relationship by just a factor of two.

Of further interest is that if one shuts off the air conditioner entirely (that is, let the second term be zero), one gets the same answer as in the first case or about 10^{-3} . So although I did not choose these numbers they are typical of a room. For all three conditions of operating that air conditioner, there is not an enormous difference between the ratios of internal to external exposure (time integrals of the concentration).

Figure 6 lists the work we have planned on transfer functions.

PLANNED TRANSFER FUNCTION WORK

ADDITIONAL FILTER TESTS: SHORTER LENGTHS
COARSE, MEDIUM, FINE
USED FILTERS
SPECIAL FILTERS: AIRCRAFT AIR CLEANERS
AIRCRAFT WATER SEPARATORS
GENERIC CABINET T.F. TESTS
FILTER T.F. MODELING
VERIFICATION OF TYPICAL ROOM/EQUIPMENT PREDICTIONS

Figure 6

I suspect its elements are rather obvious; do more filter tests at lengths down to the order of 1 millimeter or shorter. We did want to test down to this value somewhat earlier in time, but have been limited until very recently, both in terms of being able to make fibers of that length in a practical way and in sensing those fibers in the laboratory. I believe we are now in a position of running our tests down to about 1 millimeter. Various filters of different fineness will be tested. Special aircraft filters will be tested because of the specific responsibility NASA has regarding aircraft.

Generic cabinet transfer function tests are planned. These tests are on cabinets with louvers and on appliance cases with air-flow which is fairly typical of that encountered in practice.

Filter transfer function modeling will be attempted in order to predict transfer functions, and although the computations shown on the previous figures seem to be straight forward, there is a need to verify the settling terms in those equations. These may be somewhat dependent upon the amount and the scale of the turbulence that might exist within a given enclosure, and it is planned to check this under one or two sets of conditions.

Figure 7 lists some preliminary conclusions. I believe that,

PRELIMINARY CONCLUSIONS

1. A BODY OF ANALYTIC AND TEST DATA EXISTS WHICH ALLOWS COMPUTATION OF TRANSFER FUNCTIONS TO BE MADE FOR SPECIFIC INSTALLATIONS.
2. ADDITIONAL TEST DATA AND MODELING IS NEEDED REGARDING GENERAL TYPES OF ENCLOSURES FOR PERFORMING THE NATIONAL RISK ESTIMATE.
3. VERIFICATION BY TEST OF COMPUTED TRANSFER FUNCTIONS FOR TYPICAL INSTALLATIONS HAS YET TO BE ACCOMPLISHED.

Figure 7

if we have any specific installation and understand its filter, the infiltration flow rates, and forced ventilation rates, there is no question that the transfer function can be computed. However, to generalize these relationships for particular industries, homes, and other facilities in the country, additional modeling work must be done so that the national risk can be computed.

VULNERABILITY

Israel Taback
The Bionetics Corporation

The discussion of vulnerability will begin with a description of some of the electrical characteristics of fibers before defining how vulnerability calculations are done. The vulnerability results secured to date will be presented. The discussion will touch on post exposure vulnerability which many have not heard about and then hazard some guesses about what future technology will do to the measurements made to date. After a description of some shock hazard work now underway, the discussion will lead into a description of the planned effort and present some preliminary conclusions.

On the upper left hand corner of figure 1 I have diagrammed a fiber and an external circuit. Electrically, fibers appear as a resistance per unit length plus two contacts which have some non-linear characteristics. The fibers that we have been working with show resistances of about 1000 to about 3000 ohms per centimeter of length depending upon the extent of graphitization.

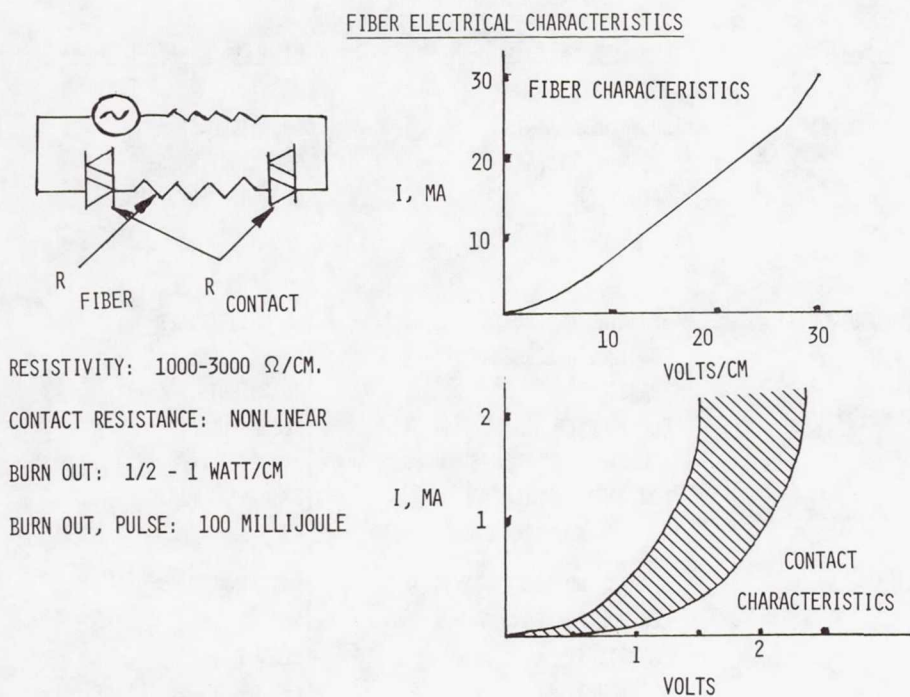

Figure 1

Their contact resistance is nonlinear. They burn out at about 1/2 to 1 watt per centimeter of length, and a one centimeter fiber will burn out with a pulse input of about 100 millijoules. If one plots the current through the fiber against the voltage across the fiber, there is a small nonlinear region at low voltage, a linear region which increases with increase in voltage, and then just before the fiber burns out and probably due to its negative temperature coefficient of resistance, a little further nonlinearity in the current voltage characteristics. Some of the fibers burn out at about 30 milliamperes; others will burn out at currents between 10 and 20 milliamperes. The contact characteristics of the fiber are somewhat similar to back-to-back diodes. The current that will pass through the fiber contact stays very low until a characteristic voltage is applied. For the fibers we have been working with it has the order of about 1½ to 2 volts. At this point the voltage drop at the contact remains fairly constant and relatively independent of current. Because of these characteristics the fibers have the potential for doing various types of damage.

Figure 2 is a fairly gross categorization chart. I have tried to generalize the types of damage that might occur with fibers based upon the voltage range that they may be used at and whether or not they are in a low power or high power circuit. One of the areas of concern is the low voltage and low power region. A fiber

<u>TYPICAL FIBER EFFECTS</u>		
<u>VOLTAGE RANGE</u>	<u>LOW POWER (UP TO 100W)</u>	<u>HIGH POWER (ABOVE 100W)</u>
LOW (0 TO 30 VOLTS)	SUSTAINED SHORTS FIBER NOT BURNED MALFUNCTIONS NO LOCAL DAMAGE	SUSTAINED SHORTS FIBER NOT BURNED NO EQUIPMENT DAMAGE
MEDIUM (30 TO 1000 VOLTS)	SPARKING OR SHORTS POSSIBLE FIBER BURN TRANSIENTS BLOWN FUSES STRESSED COMPONENTS LOW DAMAGE POTENTIAL	SOME SUSTAINED ARCS FIBER BURNS TRANSIENTS BLOWN FUSES STRESSED COMPONENTS DAMAGE USUALLY REPAIRABLE
HIGH (>1000 VOLTS)	SPARKS, NO SUSTAINED ARCS LOW VOLTAGE CORONA TRANSIENTS INTERRUPTIONS	SUSTAINED ARCS CORONA FLASHOVER MAY BE SEVERE DAMAGE

Figure 2

has the capability to maintain a high resistance short without burning out. The equipment can malfunction and although no local damage to components usually occurs the functioning of the device may be impaired. At low voltage and high power (for example a 12 volt battery circuit) shorts may also be sustained. The fiber may or may not burn out depending on the voltage; however, equipment is not usually damaged. This is not a problem area from the viewpoint that if a fiber does fall across a high power low voltage circuit, it may draw a little bit of power from the circuit but it probably would not stop the operation. The other area of concern is high power and relatively high voltage where the fiber essentially acts as a trigger to some potential arcing and that arcing may be sustained. This will stress components, blow fuses and cause flashover at insulators. There is another region where fiber can damage some types of equipment and that is in the high voltage high power area. Here one can encounter corona and initiate sustained arcs which can disrupt equipment and damage equipment.

As I say this is a very gross chart. The 0 to 30 volts may well be 0 to 10 or 15 and the 100 watts may well be anything from about half that to twice that; but the general characteristics of the types of problems listed are typical.

Figure 3 lists methods which are employed for evaluating

EQUIPMENT EVALUATION METHODS

DIRECT EXPOSURE IN TEST CHAMBER

FIBER SIMULATOR PROBE

GENERIC SIMILARITY

ANALYSIS & MODELING

Figure 3

equipment vulnerability. The most direct one, and the one I think has been used in most cases, is direct exposure of the equipment in a chamber. There are chambers at Langley Research Center, at Rome Air Development Center, and at Ballistic Research Labs in Aberdeen, Maryland. There may be a few others with which I am not familiar.

A second way of evaluating equipment vulnerability is with a fiber simulator. If the electronics or equipment has a limited number of nodes, 50 or perhaps no more than 100, it is possible to probe this equipment and determine whether or not the fiber as simulated will produce a hazard, cause the equipment to malfunction, or burn out because of the power supply characteristics in the equipment.

The third method is what some people call engineering judgment, others call guesses, and I call generic similarity. That is, if your tests are performed on one type of computer of a given complexity and there is another of about the same complexity and the same technology, one could hazard some guesses with regard to its vulnerability.

The last method is called modeling and is outlined in figure 4. Even for equipment which may be as simple as a home television set, it is probably impossible to just look at the case and hazard

VULNERABILITY MODELING

1. ANALYZE EQUIPMENT INTO DEFINABLE UNITS USING FAULT TREES AND SEPARABLE CHARACTERISTICS.
2. FOR EACH UNIT:
 - A) TYPE OF VENTILATION (CONVECTIVE, FORCED, LEAKAGE)
 - B) TYPE OF TECHNOLOGY (VACUUM TUBE, DISCRETE, INTEGRATED)
 - C) VOLTAGE RANGE (< 15V, 15-200V, > 200V)
 - D) TYPE OF WIRING (CIRCUIT BOARD, SOLID WIRE) & CONNECTORS (SPADE LUG, HERMETIC, WIRE WRAP)
 - E) ORIENTATION OF OPEN LEADS & CIRCUIT TRACES
3. USE GENERIC TEST DATA ON CIRCUIT BOARDS & CONNECTORS TO ESTIMATE FAILURE STATISTICS.
4. COMBINE, USING FAULT TREE, INTO OVERALL FAILURE RATE PREDICTION.

STATUS: PRELIMINARY LOGIC MODEL DEVELOPED

Figure 4

a guess as to its vulnerability. One way of breaking it down into things that can be handled is to break the equipment down into definable units using the fault trees and the characteristics of the individual units which make up the tree. Then each type of smaller unit could be analyzed at that level: the type of ventilation, the type of technology, the voltage range of the equipment, the type of wiring that might be in it, the orientation of the open leads and circuit traces, and whether or not there are open leads or coated circuit boards can be considered. Then, using generic test data on similar circuit boards and connectors, the statistics of failures of each of those parts can be combined into an overall failure rate prediction. We have not done very much with this other than develop a preliminary logic model. Other people that have worked in this area have used this type of modeling in order to model a complete radar system for example.

Figure 5 is a computer-generated experimental vulnerability result. The testing was done on a PDP-11 computer, and it is a plot for tests that were done at 7.8 and 4.5 millimeter length fibers. Each of the staircase steps is at least one failure and generates the approximate probability of damage curve when plotted against the exposure in particle seconds per cubic meter. The shape of this curve is typical. It is not the best fit that has been secured, but it is typical and is fitted by the equation shown on the upper left where the probability of damage is shown

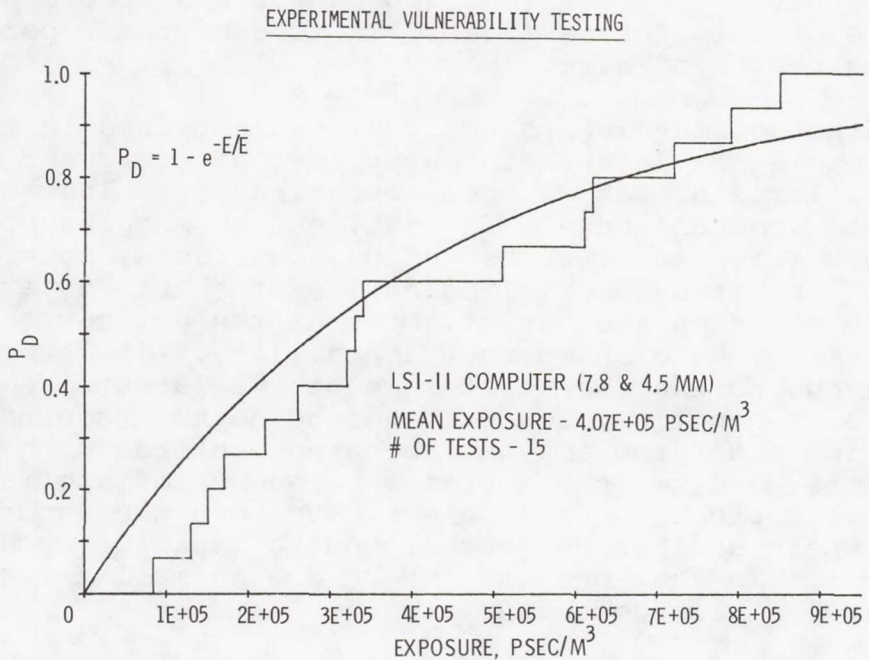

Figure 5

as an exponential. Figure 6 shows typical vulnerability results. The lengths of the test fibers are defined by 'short', 'medium', 'long'. The reason for this is that it is very difficult to cut the same length of 3 millimeter fibers so that testing might have been done anywhere from $2\frac{1}{2}$ to $3\frac{1}{3}$ millimeters, the 7 millimeter testing perhaps plus or minus a millimeter, and the long testing may be from 10 to 14 millimeters.

The small desk type computer, the PDP-11, was most vulnerable to the longer fibers in those tests. The vulnerability was approximately 10^5 and for the long and the medium lengths. The computer was a little bit less vulnerable to the shorter lengths, with \bar{E} at 10^6 . It is interesting that the first two items on this chart are both cooled with unfiltered fan-forced air, and neither one of the devices has coated circuit boards.

The next item on the figure is a color television which just barely came into our definition of vulnerable equipment. We essentially stopped testing at about 10^8 . If one puts any reasonable exposures and damage numbers into the problem of the national risk analysis, 10^8 turns out to be a vulnerability level which results in very small amounts of potential money loss. However, we still carry along in our risk estimates those devices which fail at 10^7 .

The rest of the equipment seems to be vulnerable at \bar{E} from about 10^5 up through about 10^7 . The smallest number on the chart, 2×10^4 , occurs for the very long fibers for a stereo amplifier. There is more of this data available in some of the reports which are not being presented here.

One of the outstanding things that has happened in the last period of time is the fact that many pieces of equipment were tested with a large number of them appearing not vulnerable. Figure 7 lists some of these. In fact, enough samples of consumer equipment were selected, such as radios, recorders, home music systems, etc. that they became indicative of about 75 percent of the available goods on the market. Most of the devices that have been tested so far have shown no vulnerability. It is believed that this is due to the fact that some of the latest items are somewhat newer technology, low wattage and do not require a cooling ventilation. No problems have been encountered with 110 volt electric motors and two thermostats. A number of appliances have been tested with probes. No problems have been encountered except in one case where a fiber would short out a resistor-capacitor timing circuit. In that one case there was a small timing error but no particular hazardous condition.

VULNERABILITY RESULTS - VULNERABLE

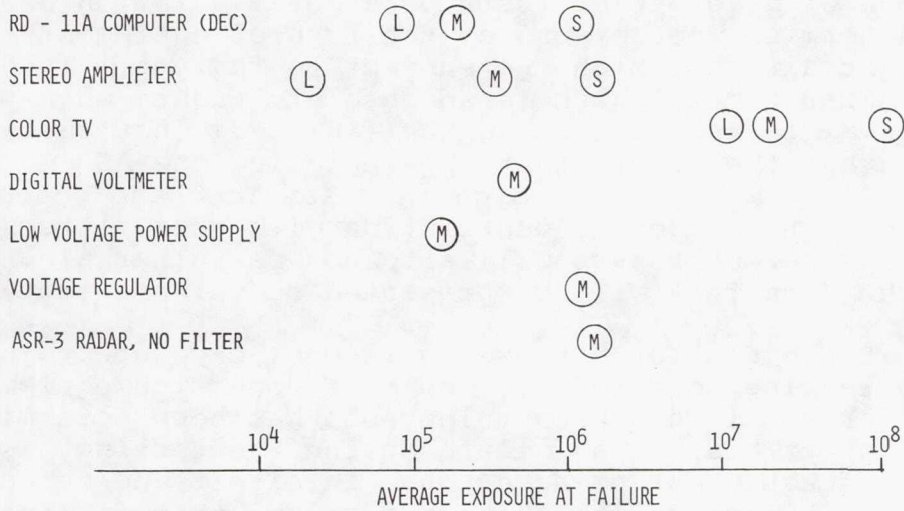

FIBER LENGTHS: (S) SHORT (~3 MM), (M) MEDIUM (~7 MM), (L) LONG (~12 MM)

Figure 6

VULNERABILITY RESULTS - NOT VULNERABLE

NOT VULNERABLE

- . AM/FM RADIO
- . CALCULATOR WITH PRINTER
- . TAPE RECORDER
- . HOME MUSIC SYSTEM
- . 10 BAND RADIO
- . ELECTRIC MOTORS 110V
- . 24V AND 115V THERMOSTATS
- . BLACK AND WHITE TV SET
- . DISHWASHER (PROBE TEST)
- . TOASTER (PROBE TEST)
- . CAR RADIO
- . GENERAL AVIATION DME
- . ASR-3 RADAR, WITH FILTER

Figure 7

The general aviation Distance Measuring Equipment (DME) was tested as one of a series of tests of general aviation equipment, to try to determine whether or not the type of equipment that might exist in light aircraft might be subject to failure. It did not fail. The ASR-3 radar, which is an obsolete radar, when tested with its normal filter as used in the field, did not fail. It is interesting that the radars that are replacing the ASR-3, which are now ASR-7's and 8's, and going into service have coated circuit boards and better control of ventilation with good filters. We believe that the newest radars will also not be vulnerable. That concludes the data that will be presented on vulnerability.

The next subject for discussion is post-exposure vulnerability. Most of the testing done to date has been done with equipment 'on', and whether or not it has been vulnerable has been determined by whether or not it has had a failure during the testing. There is the problem of equipment being exposed in either an 'on' or 'off' condition not failing during the exposure and then failing in some period of time after the exposure. One way of thinking about the problem is to think about the fibers that enter the equipment as illustrated on figure 8. There is only a limited number of things that can happen to ingested fibers. They can be exhausted immediately, which I think is what happens to most of the fibers. They can cause a problem, in which case the equipment would be taken

POST-EXPOSURE VULNERABILITY

POSSIBLE FIBER HISTORY

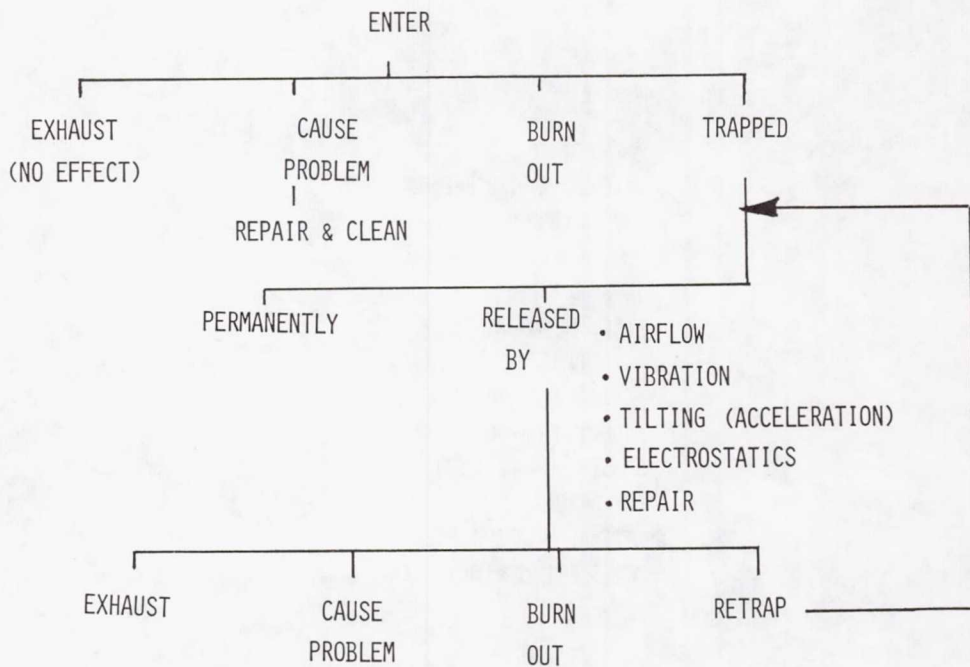

Figure 8

apart, would be repaired and cleaned and that would be the end of those fibers. They might burn out because of the voltage or power range in the equipment, or they might get trapped within the box. If they are trapped within the box they may get trapped permanently. Cases have been observed where it is extremely difficult to remove a fiber from its position in a box after exposure. The fibers could be released either by subsequent air flow, vibration, electrostatics (turning the equipment 'on' and 'off'), or by a subsequent repair that might have been occasioned by some other fault. The logic loop can be repeated many times and one can hypothesize that every operation results in working with less and less fibers. In an attempt to see whether or not this problem was worth studying, we did some preliminary pathfinder tests with two boxes.

Figure 9 outlines the test scheme. The color television and the stereo amplifier (for which vulnerability data was presented within figure 6) were exposed to about $E = 10^5$ fiber seconds per cubic meter. They were given nine exposures in an 'off', and nine exposures in an 'on' state with the supposition that there was a possible electrostatic effect that could determine where the fibers might land and might adhere. A year's operation was then simulated after each exposure. These tests are very time consuming. They took about 200 hours of testing, yet it is apparent that we really did not simulate the number of on-off switches that

POST-EXPOSURE VULNERABILITY

TEST METHOD

- . FIBER EXPOSURE 10^5 FIBER SECONDS/METER³
- . NINE EXPOSURES IN "OFF" + NINE IN "ON" STATE
- . SIMULATE ONE YEAR'S OPERATION AFTER EACH EXPOSURE
 - 100 ON/OFF SWITCHES (EACH TWO MINUTES)
 - 50 PHYSICAL MOVEMENTS
 - 50 BLOWER OPERATIONS

RESULTS

- . NO POST-EXPOSURE FAILURES CAUSED BY GRAPHITE FIBERS FOR COLOR TV OR STEREO AMPLIFIER

Figure 9

occur in a normal television in a year. The 50 physical movements is probably about right, and the lower operations where opened windows or fans were simulated are reasonably realistic.

Results to date are that no failures have occurred on either box. This work will continue with some more devices but so far the results look promising. It may not be a big problem.

Figure 10 offers conjectures with respect to the effects of future technology. Some of this technology is already in use and the effects are apparent in the testing of consumer appliances. I believe there will be more coated circuit boards than at present. One of the reasons for this is that manufacturers are beginning to do wave soldering and it is economical to coat the board in order not to waste solder. There is an increased use of integrated circuits as compared to discrete items, therefore less leads, lower power requirements, and no need for cooling openings into the case. When people build equipment nowadays they are more sensible about specifying filters. This seems to be particularly true of field equipment such as being specified by the FAA for airport use. Improved ventilation practices in general, in homes and in offices, should improve the situation; the only thing that looks a little black is the tremendous rate of increase of the amount of electronics in use.

FUTURE TECHNOLOGY EFFECTS ON VULNERABILITY

	<u>REDUCES</u>	<u>INCREASES</u>
INCREASED USE OF COATED CIRCUIT BOARDS	X	
INCREASED USE OF INTEGRATED CIRCUITS	X	
LOWERED POWER REQUIREMENTS	X	
IMPROVED FILTRATION SPECIFICATIONS	X	
IMPROVED VENTILATION PRACTICES	X	
MORE ELECTRONICS IN USE		X

Figure 10

One more subject which has not previously been discussed is the potential of a shock hazard. Figure 11 diagrams how 110 volt power is conducted into a normal home or office. There are usually three leads, a "hot" lead at 110 volts, a neutral lead which is usually at the same potential as ground, and a ground lead. When these come into the home, and an appliance of any kind is plugged in, and if a cheater plug is not used, then the external case is connected to ground. The neutral lead and the hot lead enter the case and either a one pole or a two pole switch makes the connection to the internal circuit.

If fibers are ingested into the case there is a potential short between the wiring in the case and the case. If a human being touches the case and has a resistance to ground, he completes the circuit through himself from the 110 volt source.

Figure 11 also lists some typical resistivities resulting from barely touching a case with everything dry, in which case the resistance is in megohms, to touching it with various degrees of wetness and area. For each of these contacts with different resistivity, the current through the human being can range all the way from where he might feel a mild shock to where he can be at a "no-let-go" condition (no voluntary control over the muscles). In fact, at 30 milliamperes he may be subject to ventricular fibrillation.

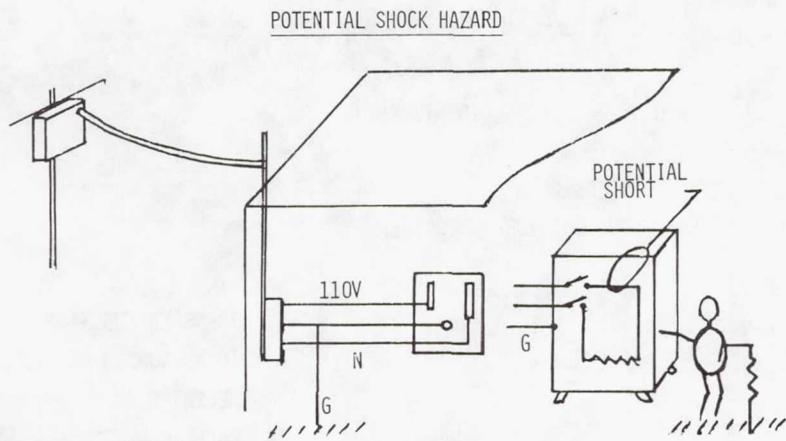

<u>CONTACT</u>	<u>RE: OHMS</u>	<u>CURRENT AMP</u>	<u>EFFECT</u>
DRY, TOUCH CASE	MEGOHMS	-	NONE
DRY, FINGER-THUMB GRASP	30 K	.003	MILD
WET, FINGER TOUCH	20 K	.005	ANNOYANCE
DRY, HAND HOLDING PLIER	10 K	.009	"NO-LET-GO"
DRY, PALM TOUCH	3 K	.030	VENTRICULAR FIBRILLATION
FOOT, ON DAMP LEATHER	12 K	.009	"NO-LET-GO"
FOOT, ON WET CONCRETE	1 K	.110	FIBER BURNS OUT

Figure 11

lation. There are really very few appliances that are of concern. Electric heaters and some metallic-cased small electric tools offer some hazard; however, the most serious concern is the familiar home toaster. It is believed that the toaster is the biggest problem that exists because of the large numbers in use.

Figure 12 lists some assumptions which were made to determine whether further work in this regard is needed. It was assumed that there are 2000 pounds of fiber in each of five fire-accompanied accidents per year, that ten percent of the graphite fiber was released, that there are a thousand people per square kilometer (typical of many urban areas), and that the average everyday family has a toaster, with three people in a family. A 0.01 transfer function from the outside to the inside of the home was also assumed; however, 0.01 may be a little bit large with respect to computed transfer functions into a home with windows and doors closed. The transfer function could be unity if the home had wide open windows or doors.

The determination of the hazard is made by applying an estimation formula which includes: the probability of a shock hazard as linearly related to the density of the toasters per unit area; the transfer function into the enclosure where the toaster exists; an inverse proportion to the \bar{E} necessary to produce the shock hazard; a direct proportion to the number of fibers that are re-

PRELIMINARY ESTIMATE OF TOASTER SHOCK HAZARD

ASSUMPTIONS

- 2000# FIBER IN EACH OF 5 FIRE ACCIDENTS/YR
- 10% FIBER RELEASE
- 1000 PEOPLE (330 TOASTERS) PER KM²
- 0.01 TRANSFER FUNCTION, OUTSIDE TO TOASTER

$$P_{\text{SHOCK HAZARD}} = \left(\frac{\text{TOASTERS}}{\text{AREA}} \right) \left(\frac{\text{T.F.}}{\bar{E}} \right) \left(\frac{N}{V_s} \right), \quad \text{WHERE:}$$

- T.F. TRANSFER FUNCTION
- N, TOTAL NUMBER OF FIBERS RELEASED
- V_s FALL VELOCITY
- \bar{E} , AVERAGE EXPOSURE WHICH CAUSES A SHORT

$$P_{\text{SHOCK HAZARD}} = \left(\frac{330}{10^6} \right) \left(\frac{10^{-2}}{10^8} \right) \left(\frac{10^{12}}{2 \times 10^{-2}} \right) = 1.6 \text{ POTENTIAL HAZARDS/YEAR}$$

(FOR $\bar{E} = 10^8$ TOASTER)

$$\left(= 1600 \text{ (FOR } \bar{E} = 10^5 \text{ TOASTER)} \right)$$

NOTE: 10^8 AND 10^5 DETERMINED WITH 7 MM FIBERS.

Figure 12

leased in the accident; and an inverse proportion to the fall velocity of the fibers.

This formula for integrated exposure has been checked a number of times against specific footprints that have been computed and it is a good conservative estimator. If the footprint covers a uniformly settled area, it will provide a conservative estimate of the amount of damage. This formula is similar to one expression used to calculate dissemination footprints. Two toasters were tested. There were actually three submitted. One toaster that was tested required an \bar{E} of about 10^8 in order to produce a shock hazard; and, if all the correct numbers are applied to the formula, it computes about 1.6 potential hazards per year for that toaster. The second toaster that was tested has an \bar{E} of 10^5 . That equates to be about 1600 potential hazards per year. That does not mean that there is a hazard. There is a potential hazard. The accompanying proper resistivity of the human being to do some damage is required as well. We did check the third toaster, but interestingly enough, it required an \bar{E} of zero because it was shorted when submitted to the laboratory. These tests were all done with 6 millimeter fibers. These tests will be repeated with shorter fibers. The computations show values large enough so that we have to further analyze the problem.

Figure 13 lists some reasons for believing that the computed

PRELIMINARY SHOCK HAZARD CONCLUSIONS

1. THE RISK IS LOWER THAN ESTIMATED FOR THE ' 10^5 TOASTER':
 - A) LATEST SOURCE DATA INDICATES SHORTER FIBERS ARE PREDOMINATE IN RELEASE SPECTRUM.
 - B) NEW SAFETY STANDARDS ISSUED IN 1973 REGARDING TOASTER CONSTRUCTION.
 - C) ONLY 10 TO 50% OF TOASTERS IN USE ARE OF 10^5 TYPE.
 - D) SIMULTANEOUS PROBABILITY OF REQUIRED HUMAN RESISTANCE TO GROUND IS LOW.
 - E) PLUG MUST BE INSERTED SUCH THAT HAZARD IS PRESENT.
2. ADDITIONAL EFFORT IS REQUIRED:
 - A) SECURE MORE DATA REGARDING SHOCK HAZARD VS. EXPOSURE VS. FIBER LENGTH
 - B) SECURE MORE INFORMATION REGARDING USE RATE AND OBSOLESCENCE OF TOASTERS.
 - C) COMPUTE NATIONAL RISK USING DETAILED RISK ANALYSIS METHODS.

Figure 13

hazard is probably too large. The latest source data indicates that shorter fibers are predominate in the release spectrum. I believe that the shock hazard is probably less than indicated for the shorter fibers. The second item is that there were new safety standards introduced in 1973 regarding toaster construction. We really do not know how many are out in the field of each type. Estimates were made by some people at the Bureau of Standards Consumer Safety Group; they estimated that for the toasters considered susceptible they would guess only 10 to 50 percent of the ones in use are of that type. Perhaps there is one other small factor, and that is that the plug must be inserted so that the hazard is present.

Possibly the biggest safety factor of all is that whatever number is computed by the methods shown must be multiplied by the simultaneous probability of getting the right human resistance to ground. We honestly do not know the probabilities for this event. More data is required regarding the shock hazard versus exposure and fiber length. More data regarding the use rate and the obsolescence of toasters is also needed. Apparently the newer ones may be safer. Finally the national risk should be computed using detailed risk analysis methods rather than the kind of estimating scheme shown.

Figure 14 shows work that is planned. There is a specific

PLANNED EFFORTS

VULNERABILITY TESTING

APPLIANCES & ADVANCED ELECTRONIC CONTROLS

CONSUMER EQUIPMENT

INDUSTRIAL EQUIPMENT

AIRCRAFT EQUIPMENT

GENERIC TESTING:

. CONNECTORS

. CIRCUIT BOARDS

. TYPICAL COMPONENT INSTALLATIONS

VULNERABILITY MODELING

Figure 14

worry about appliances that may show up on the market with advanced electronic controls. Some tests are planned on consumer equipment, industrial equipment, and on aircraft equipment. Testing is being accomplished and will continue on particular types of connectors and circuit boards. Vulnerability models are being developed so that it will not be necessary to test every electronic box in the country.

A few conclusions from the work that has been done so far are shown on figure 15. It is not difficult to take any specific box or any specific installation and do the necessary experiments and evaluate that particular installation. However, it still looks fairly difficult to do a national risk estimate because of the difficulty of modeling things such as complete industries in terms of what kinds of equipment they have and how much they may have in a plant. It is believed that the use of new technology will tend to reduce the risks because of the smaller size, the better encapsulation and the lower wattage. To date no problems have been encountered with any 110 volt equipment (motors, appliances) and none are expected unless electronic controls are used. This is primarily because with the 110 volt equipment in general use when the fibers cross a pair of nodes, they will burn away. The testing that has been done so far of a sample of consumer electronics indicates very little vulnerability. In fact none were found in the group that was tested. More work is indicated on the toaster shock hazard analysis in order to determine whether a serious problem exist.

PRELIMINARY CONCLUSIONS

1. ANY SPECIFIC INSTALLATION CAN BE EVALUATED FOR RISK WITH AVAILABLE TEST & ANALYSIS CAPABILITY, HOWEVER;
2. TO SECURE CONFIDENCE IN A NATIONAL RISK ANALYSIS ADDITIONAL TESTING & MODELING IS REQUIRED.
3. USE OF NEW TECHNOLOGY WILL TEND TO REDUCE THE RISK.
4. NO PROBLEMS HAVE BEEN ENCOUNTERED TO DATE WITH 110V EQUIPMENT (MOTORS, APPLIANCES) AND NONE ARE EXPECTED UNLESS ELECTRONIC CONTROLS ARE USED.
5. TESTS OF A SAMPLE OF CONSUMER ELECTRONICS INDICATE LITTLE VULNERABILITY.
6. PRELIMINARY TOASTER SHOCK HAZARD ESTIMATES INDICATE ADDITIONAL EFFORT IS REQUIRED.

Figure 15

Page intentionally left blank

Richard A. Pride
NASA Langley Research Center

With all the testing that has been done to determine vulnerability and failure of equipment, we still have not identified an occasion in which electrical or electronic equipment has failed because of carbon fibers released by the burning of composite parts in an aircraft-fuel fire. Therefore, the principal objective, figure 1, of the kinds of demonstration testing that I will discuss is to try to verify whether or not carbon fibers that are released by burning composite parts in an aircraft-fuel fire can produce failures in electrical equipment. A secondary objective is to experimentally validate the analytical models for some of the key elements in the risk analysis; source, dissemination, transfer function, and vulnerability of equipment.

The approach to this demonstration testing (figure 2) is two-fold; we are going to be conducting limited end-to-end tests at Dahlgren, Virginia, in the Naval Surface Weapons Center shock tube, and we are planning for some large outdoor burn tests at the Army's Dugway Proving Ground in Utah. There are certain qualifications for the large outdoor tests which will be discussed later. For now, I want to indicate that we do have these two types of tests in various stages of planning and development.

RISK ANALYSIS DEMONSTRATION TESTING

OBJECTIVES

- VERIFY WHETHER CARBON FIBERS RELEASED BY BURNING COMPOSITE MATERIAL PARTS IN
A REAL AIRCRAFT-FUEL FIRE WILL PRODUCE FAILURES IN ELECTRICAL EQUIPMENT
- EXPERIMENTALLY VALIDATE ANALYTICAL MODELS FOR
SOURCE
DISSEMINATION
TRANSFER FUNCTION
VULNERABILITY OF EQUIPMENT

Figure 1

RISK ANALYSIS DEMONSTRATION TESTING

APPROACH

DAHLGREN NSWC - SHOCK-TUBE TESTS

ARMY DUGWAY PROVING GROUND - LARGE OUTDOOR BURN TESTS

Figure 2

Our objectives at Dahlgren (figure 3) are to verify the vulnerability of equipment to fire-released fibers and to identify some of the problems that would be associated with end-to-end tests that will be even more significant if we go outdoors. Our approach is to develop a burn and exposure facility in the shock tube for doing these end-to-end tests and then to subject typical vulnerable equipment to critical exposures of fire-released fibers along with the associated soot and smoke. When jet fuel is burned in open fires, a lot of smoke and soot is generated due to the fuel-rich type of combustion. The photograph from Vernon Bell's source paper of the outdoor pool fire at China Lake showed that it was certainly generating a lot of smoke. It was not clean burning by any means. Our smaller JP-1 fuel fires in the Dahlgren shock tube were also very smoky and sooty.

The Dahlgren shock-tube tests provide an opportunity to experimentally validate only a few of the elements of the risk analysis flow chart, figure 4, but these are probably the most important elements. For the source fire, we are using a controlled burning rate JP-1 commercial jet fuel. There is not much difference in combustion with JP-1, JP-4, or JP-5. We did try to make it realistic for the civil aviation situation by specifying JP-1. We are going to burn graphite composite parts from structural test programs at Langley. Combustion temperatures in the vicinity of those parts will be controlled from about 930 to 980°C

DAHLGREN NSWC - SHOCK TUBE TEST

OBJECTIVES

- VERIFY VULNERABILITY OF EQUIPMENT TO FIRE-RELEASED FIBERS
- IDENTIFY PROBLEMS ASSOCIATED WITH END-TO-END TESTS

APPROACH

- DEVELOP BURN-EXPOSURE FACILITY FOR END-TO-END TESTS
- SUBJECT VULNERABLE EQUIPMENT TO CRITICAL EXPOSURES OF FIRE-RELEASED FIBERS WITH ASSOCIATED SMOKE AND SOOT

Figure 3

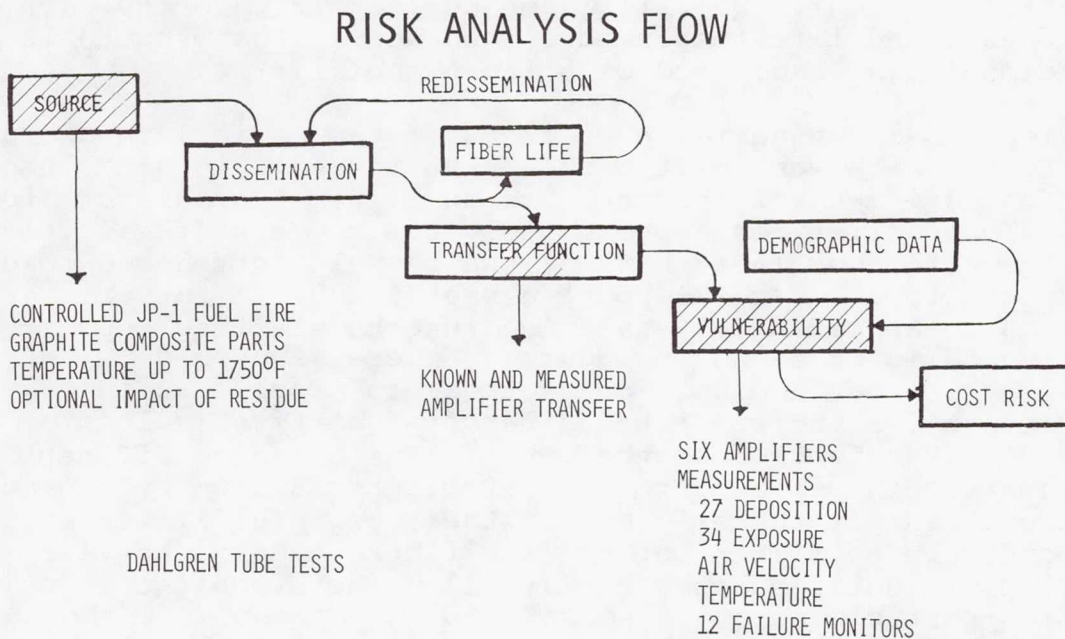

Figure 4

(1700-1800°F), and we will have a facility that has the option of agitating the residue after it has been burned, in order to study the difference in the amount of fibers that are released from just a burn compared to those released from an agitation towards the end of the burn. Because we are working inside a tube, we will not be getting much information about dissemination. We will not be able to measure plume parameters or downwind transport of the fibers in the sense that we can verify models that are developed for outdoor atmospheric dissemination. We will be disseminating fibers, but they will be constrained to stay within the walls of the shock tube at Dahlgren.

We will be getting some limited transfer function data, primarily the transfer function that is associated with the fibers being pulled inside the case of the fan-ventilated stereo amplifiers that we expect to be exposing for vulnerability at the target table in the shock tube. Our present plans are to expose a sample of six amplifiers. Failure characteristics have been established for these amplifiers based on chamber testing. They are reasonably low cost pieces of electronic equipment, and we think we understand pretty well the kinds of failure modes that are most apt to occur when they are exposed to carbon fibers. These amplifiers are representative of a class of generic circuit board equipment. They will allow us to determine failure rates when exposed to fire-released fibers for comparison with those rates that have been previously established for chamber-released fibers. In the shock-tube tests we will be measuring both deposition and exposure levels for fibers in the vicinity of the amplifier locations. We will be measuring air velocity, air temperature, and fire temperature, and we will have up to 12 failure monitors associated with the 6 amplifiers.

Figure 5 is an aerial photograph of the conical shock tube at Dahlgren which was built back in the mid-60's to study the effect on equipment of the pressure wave from a simulated atomic blast. The facility is approximately 0.8 km (a half-mile) long. It starts with four 16-inch naval gun barrels butted end-to-end, and expands to a 7.3-m (24-foot) diameter tube at the exit end. We are using approximately half the length, starting opposite the white building shown in figure 5, where we opened up the tube by taking out a couple of sections to provide an inlet. The fire pan for the simulated aircraft-fuel fire is located about 60 m (200 feet) from the inlet. The airborne effluent from the fire is pulled out through a filter system by a group of exhaust fans at the exit end of the tube. The filter system has been shown to filter out all the fibers and the heavier particles of soot, and essentially allow the discharge of only very-fine-particle soot and smoke into the atmosphere. We have monitored the particle content of the filtered smoke, and we have determined that the size of soot particles is less than 4 microns in diameter. We think our filtering system is very effective in taking out any particle sizes greater than 4 microns.

DAHLGREN NSWC - SHOCK TUBE

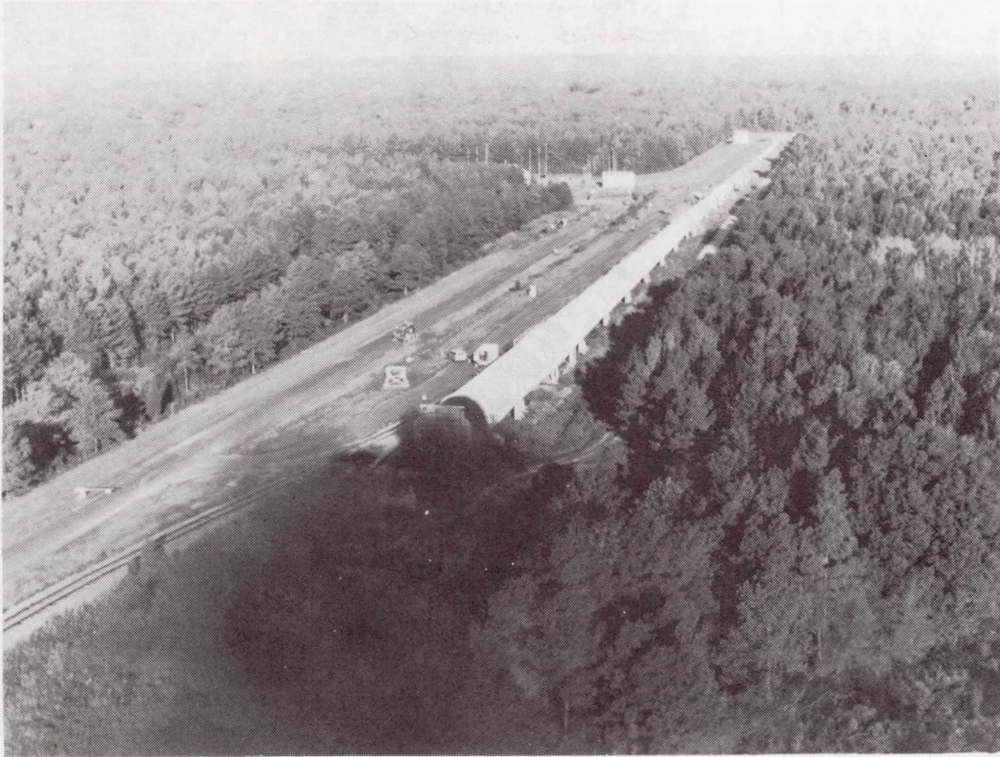

Figure 5

Figure 6 is a photograph of the inlet end of the tube. At this point, the cross section of the tube opened to the atmosphere is 3 m (10 feet) in diameter, which permits sufficient fresh air to be drawn in to feed the fire. The fire pan is shown in figure 7. We have two sizes of pan built up together, a 1.2-m (4 feet) square inner pan and a 2.4-m (8 feet) square outer pan, giving us the capability of building two different size fires, depending on the particular experiment requirements. Fuel is pumped at a controlled rate in through the bottom of the pan, which is kept flooded with water. Behind the fire pan is an array of tubing supporting a series of thermocouples that were used to survey and monitor flame temperature at locations downwind of the fire. Figure 8 is a photograph taken, from inside the tube, of one of the development fires. Modifications made since that time include a chimney around the fire pan to get the fire to stand more nearly vertical. With the addition of a chimney we have been able to provide a larger area in the flames in the 930-980°C (1700-1800°F) temperature range in which to mount the composite specimen for burning.

The combustion products and fibers from the burned composite are pulled through the tube approximately 210 m (700 feet) to the location of the target table, figure 9. This is a table that is about 5 m (16 feet) wide and 9 m (30 feet) long. The vulnerable electronic equipment will be exposed on this table and connected

SHOCK-TUBE INLET

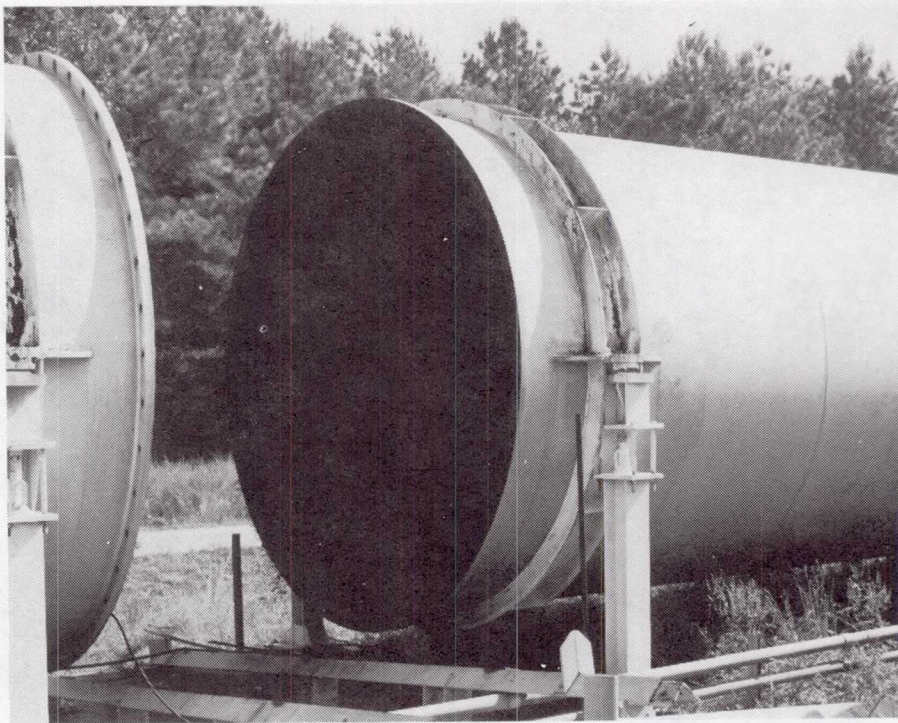

Figure 6

SHOCK-TUBE FIRE PAN

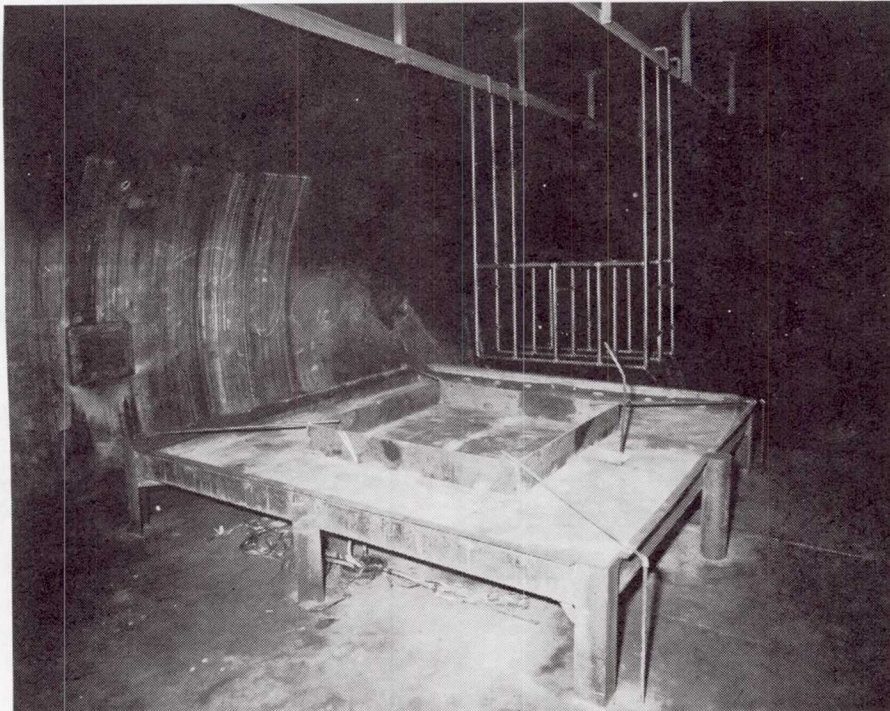

Figure 7

DEVELOPMENT FIRE IN SHOCK TUBE

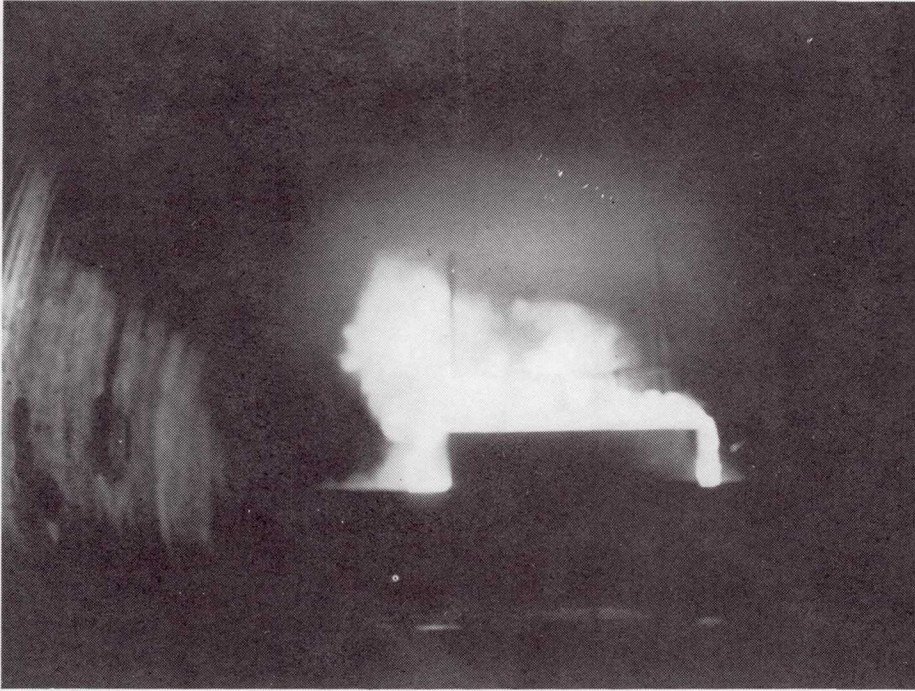

Figure 8

SHOCK-TUBE TARGET TABLE

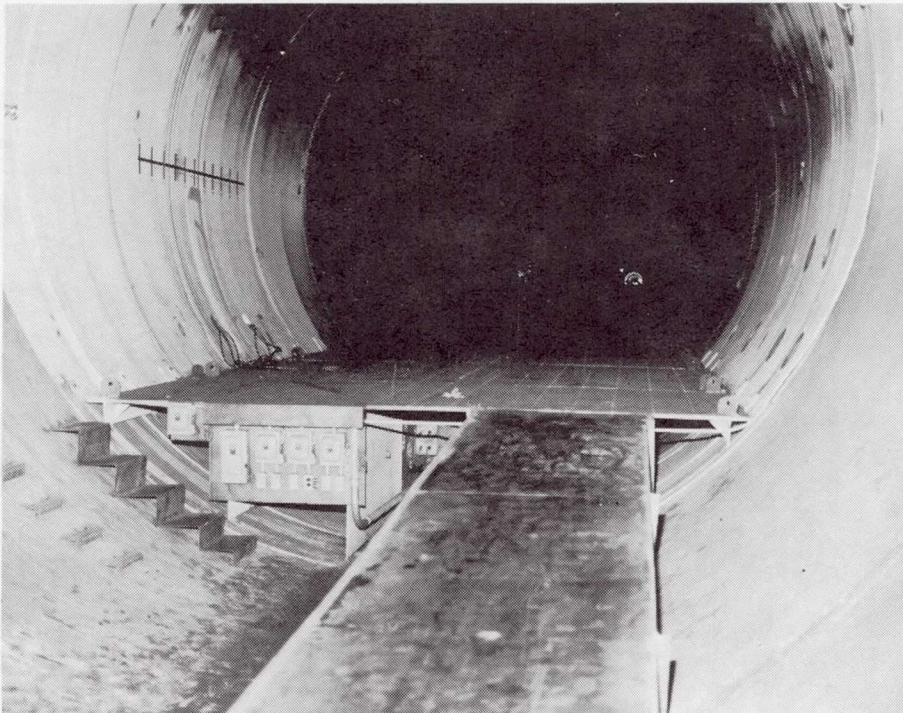

Figure 9

to the electrical switch boxes shown. There are some wires standing up from the surface of the table. Those wires hold the sticky cylinders that we use to measure the fiber exposure. A propeller anemometer is also on the table to measure local air velocity. This particular view is looking up the tube towards the location of the fire pan. The opening that can be seen at the end is where the section of the tube was removed for the inlet. Note that there is an indication of deposition of soot on the upper portions of the tube wall. There appears to be a fair amount of stratification in the airflow coming down the tube. The bulk of the soot tends to be near the top, but there is an ample deposition of soot all over the table and on the floor of the tunnel in that location.

Figure 10 is a picture of the filtering system. In the background is a framework which supported an initial attempt at building a filter wall which consisted of fiberglass furnace filters. They were very effective in taking out particles of soot and fibers; however, they became clogged in about three minutes of operating time, stopping the airflow and choking the fire upstream. We are looking for operational times on the order of 20 minutes on a particular burn. In the foreground is the current filter system which is basically a fire-fighting type water-spray fogging nozzle. A fire hose is connected to the inclined supply pipe supported on the scaffold. The nozzle is at the upper end. This nozzle emits an effective fog of fine par-

SHOCK-TUBE FILTERING SYSTEM

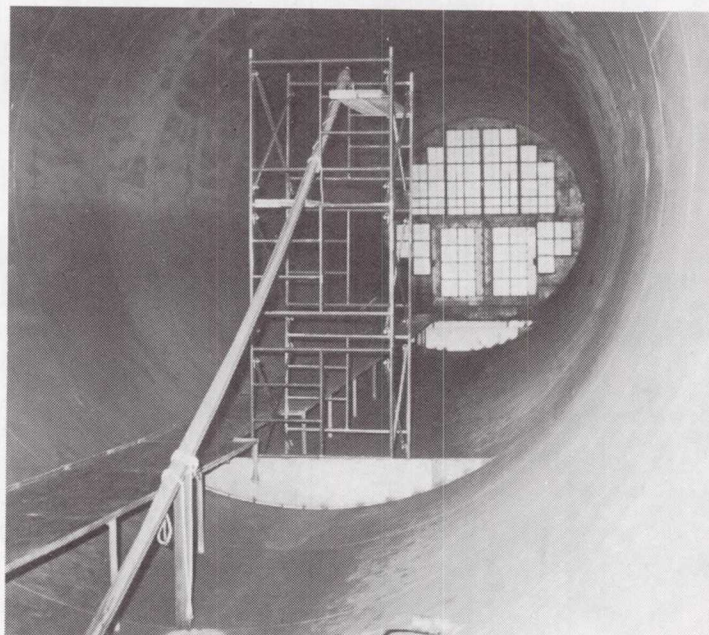

Figure 10

ticle water which washes fibers and soot particles greater than 4 microns in diameter out of the airstream. We think it also washes out a considerable number of particles under 4 microns, but it does not capture all of them. The washed out fibers, soot, and water collect on the floor of the tube and then are filtered between a series of baffles shown in figure 11. We have a skimming system which allows the water to run under these baffles in a controlled manner and retains the soot and fibers that are floating on the surface. The water drains through a hole in the floor of the shock tube. We have been monitoring the output of particles and fiber by deposition on sticky cylinders in the exhaust end of the tunnel. The filtering system has been working very effectively.

Figure 12 is a photograph of the exhaust end of the shock tube. Six exhaust fans were installed in the bulkhead in the end of the tube. Access to instrumentation is through a steel door which is closed and locked prior to testing. The six exhaust fans have variable speed control, providing a wide range of air-flow ranging from essentially zero up to a maximum of about 3400 cubic meters per minute (120 000 cubic feet per minute). Typically we are operating at about 1130 cubic meters per minute (40 000 cubic feet a minute) which gives us an average velocity over the target table of about 0.5 m/sec (1.2 miles per hour).

DRAIN BAFFLES IN SHOCK TUBE

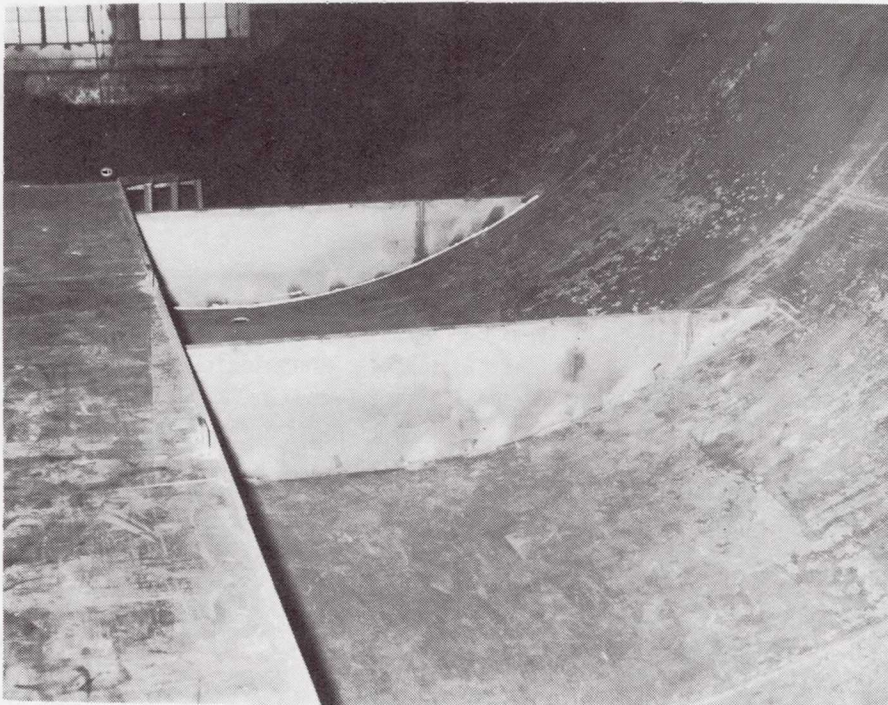

Figure 11

SHOCK-TUBE EXHAUST

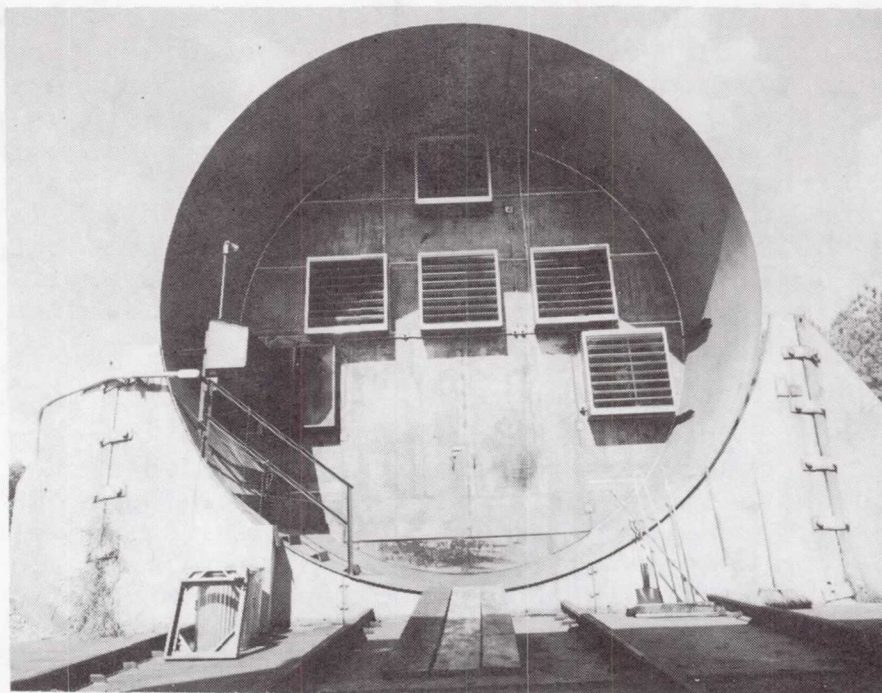

Figure 12

One of the first graphite composite samples that was burned in the shock-tube fire was monitored for fiber release with sticky cylinders at the target table. Sticky cylinders are made by rolling a 50-mm (2 inch) square piece of sticky paper into a cylinder with the sticky surface on the outside and mounting it on a wire with the cylinder axis perpendicular to the airflow. Figure 13 is an enlarged photograph of a portion of one of the sticky cylinders after exposure and after cutting it open to flatten it. This part of the sticky cylinder shows a cluster of about six fibers ranging in length from 3 to 15 mm. Those six fibers on that particular sticky cylinder represent an exposure of about 10^4 fiber-seconds/cubic meter for a 20 minute fuel burn. That is not enough for the levels that are needed to generally produce electrical failures, but considering that it was our first attempt at burning composite in that facility, we were quite encouraged.

Figure 14 is a photograph of a circuit board out of an amplifier that failed in chamber testing. It represented an electrical short caused by a fiber getting across a critical element in the amplifier, which then caused both the transistor and a resistor to burn out. There is a lot of smoke, oil, and soot associated with the burn out, which created a failure in that particular case and is an indication of the kinds of failures that can occur on this type of equipment in chamber testing. I should say that, in connection with our preparation

GRAPHITE FIBERS DEPOSITED FROM FIRST COMPOSITE SPECIMEN
BURNED IN JET FUEL FIRE AT DAHLGREN



| 1 mm |

Figure 13

AMPLIFIER CIRCUIT BOARD FAILURE

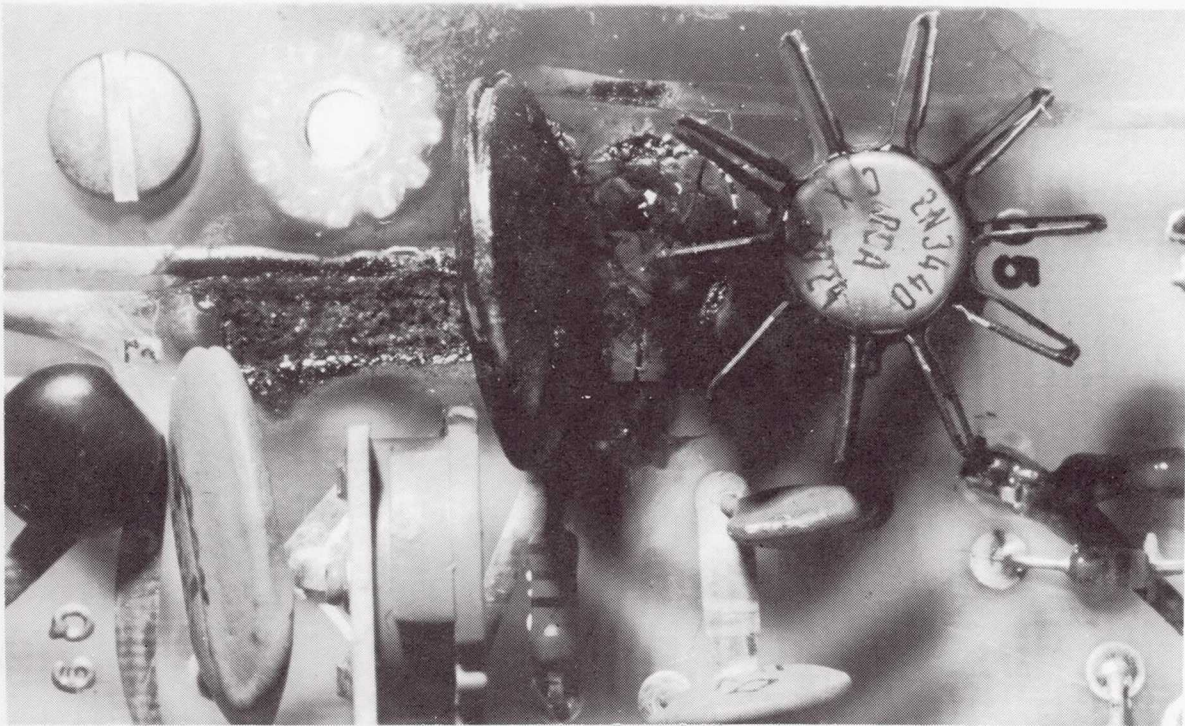

Figure 14

for testing in the shock tube, we have exposed these amplifiers without fibers in the tube for periods up to an hour to determine if smoke and soot would cause a failure. There was no indication of failure.

The typical failure curve that has been obtained on these stereo amplifiers in the chamber testing is shown in figure 15. For this equipment, 27 tests produced 27 failures with a mean exposure for the failures of 8.48×10^5 fiber-seconds/cubic meter. These were tests at various fiber lengths, ranging from 3 to 14 millimeters. The indications from those early sticky cylinders exposed in the shock tube are that the fibers we have seen so far range in length from less than 1 mm to about 15 mm. But again this is preliminary data. Future effort will be directed towards increasing the number of released fibers to achieve exposure levels comparable with chamber tests.

The second part of the two-fold approach to demonstration testing would be to go to Dugway Proving Ground for outdoor, end-to-end tests, figure 16. Dugway is not the only place in the United States where this type of test might be conducted; however, it does provide a location which appears to be quite satisfactory for doing large outdoor burns of graphite composites for the purpose of verifying the kinds of risk analysis elements that are

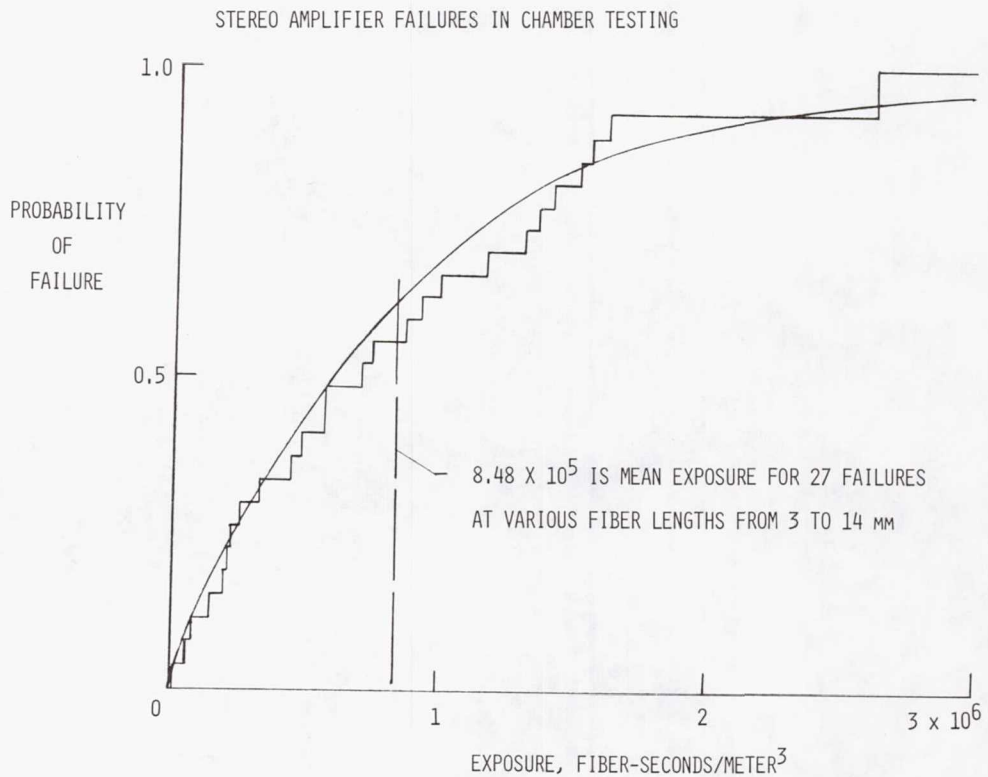

Figure 15

DUGWAY PROVING GROUND END-TO-END TESTS

OBJECTIVE

LARGE OUTDOOR BURN FOR VERIFICATION OF RISK ANALYSIS ELEMENTS

APPROACH

USE ACCIDENT EXPERIENCE TO DEVELOP CREDIBLE FIRE SCENARIOS
USE TEST EXPERIENCE AND RISK ANALYSIS TO SELECT EXPOSED ELECTRICAL EQUIPMENT
PREPARE PRE-TEST PREDICTIONS OF: FIBER RELEASE
FIBER DISPERSION AND PENETRATION
PROBABLE EQUIPMENT FAILURES
MEASURE ALL VARIABLES KNOWN TO INFLUENCE FINAL RESULTS
COMPARE PRE-TEST PREDICTIONS WITH TEST RESULTS

MANDATORY PREREQUISITES

ESTABLISHED CONFIDENCE IN: FIRE PLUME PREDICTIONS
FIBER RELEASE PREDICTIONS
MODELS FOR FIBER DISSEMINATION

CONCERNS: IF WIDESPREAD DISSEMINATION FOOTPRINTS - TEST MAY BE IMPRACTICAL

Figure 16

shown in figure 17. In this case if we go outdoors, we not only have the capability of verifying source but we can also verify outdoor dissemination. We can verify in a more effective manner a number of transfer functions and the vulnerability of suitable electrical equipment. Our approach is to use the accident experience that is being generated by the three commercial airplane manufacturers, using their data to select a creditable scenario for a fire for the source of fiber release. We will use our test experience in the risk analysis program to select the appropriate kinds of electrical equipment to be exposed. We want to be able to prepare pretest predictions for the amount of fibers to be released, their dispersion and penetration, and the probable equipment failures that will result from a test of that sort. We need to have the capability of measuring all the variables that are known to influence the final results. That is one of the reasons Dugway is considered to be a favorable location. In their past experience with airborne release of a number of chemical agents for the army, they have built up a very comprehensive network of meteorological stations, so they have a knowledge of the weather conditions over the entire range at the time of release as well as before and after release. We will be able then to modify our pretest predictions with the weather conditions actually present.

RISK ANALYSIS FLOW

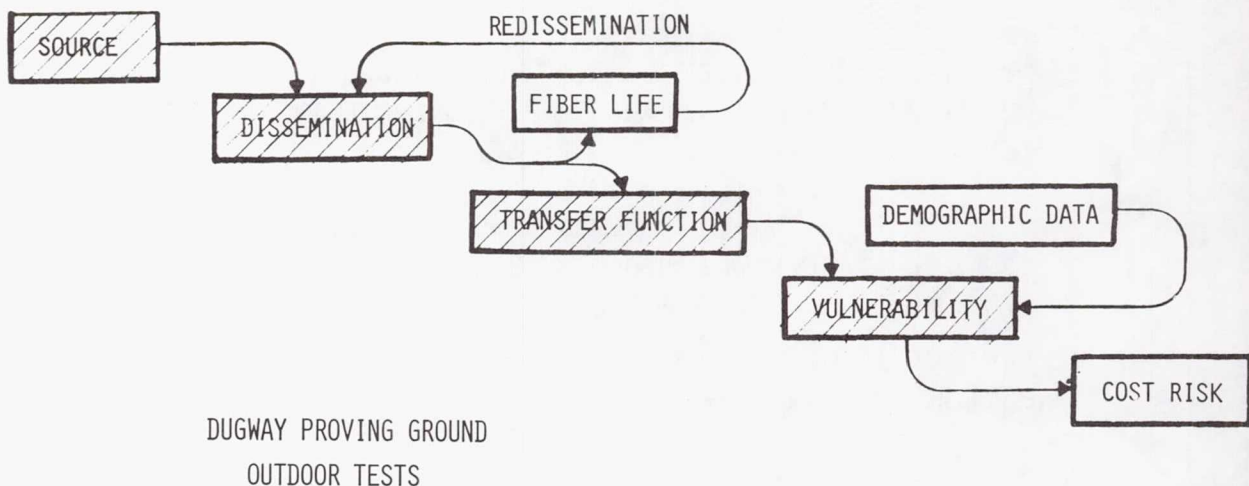

Figure 17

We do have a couple of mandatory prerequisites to conducting the end-to-end test. We need to have already established confidence in our fire plume predictions, in the fiber release predictions, and in the models for fiber dissemination. Until we have a good level of confidence established, it is probably futile to go outdoors and start burning composites. Our chances of finding fibers, knowing where they are going, and catching them again would be quite uncertain. One concern is that if we get a widespread dissemination footprint, the available fibers are scattered over such a large area that the whole test may become impractical to perform from the experimental point of view. That is not to say that the problem is not there; it just becomes very difficult to try to track down the results.

Question:

What is the rationale for burning fiber first and then exploding it? Isn't this kind of the reverse of what it should be?

Answer:

The impact, or explode, and then burn seems to be the general scenario for commercial aircraft accidents. We do not have the final answers in from the aircraft manufacturers, but the preliminary indications are that for most of the commercial aircraft accidents the plane crashes and burns. Then, if there is an impact, it will be a low-order type impact. It will not be an explosion. A major impact like a crash occurs before the fire and really does not have anything to do with disseminating carbon fibers. The crash would scatter parts of the airplane around, but the fibers can not be scattered until after they have been released from the composite by burning out the matrix. You have to have a fire to burn the matrix out before the impact or explosion is going to have a significant effect on scattering fiber. Most of the civil accidents that have been investigated do not have the kind of explosion that occurs after the fire has burned out the epoxy matrix. I am sure there are going to be a number of exceptions to the above crash and burn situation, but I think, for civil aircraft, you generally do not have the burn and then explode situation.

Page intentionally left blank

SURVEYS FOR SENSITIVITY TO FIBERS
AND POTENTIAL IMPACTS FROM FIBER
INDUCED FAILURES

A. J. Butterfield
The Bionetics Corporation

The surveys for sensitivities to fibers and potential impacts from fiber induced failures begins with a review of the survey work completed to date and then describes an impact study involving four industrial installations located in the Virginia - southeast area. The observations and results from both the surveys and the study provide guidelines for future efforts.

The surveys have been performed by a number of teams working more or less together. Figures 1 and 2 summarize the status of surveys conducted to date.

The survey work was done with three broad objectives:

1. Identify the pieces of potentially vulnerable equipment as candidates for test.
2. Support the transfer function work by gaining an understanding of how fibers could get into a building.
3. Support the economic analysis by understanding what would happen if fibers precipitated a failure in an item of equipment.

The surveys completed to date have covered both commercial and public service installations. Figure 1 begins with hospitals where the Hill-Burton Act sets the requirements for a hospital to receive federal aid. The Hill-Burton specifications define a minimum level of air filtration for operating rooms, cardiac care units, and intensive care units in terms of a triple filtration system: a pre filter; a secondary filter; and the last stage as a high efficiency (HEPA) filter. The rest of the equipment in a hospital correlates to electronic items in general use throughout the rest of the country. Hospitals live with a lint environment; therefore hospital equipment tends to have good covers. Life critical equipment appears well protected.

For air traffic control, the surveys included the tower and area traffic control centers outside of Boston plus the Washington National Tower. The radars, the control rooms, the IFR rooms, and

SURVEYS COMPLETED

<u>LOCATIONS SURVEYED</u>	<u>BY</u>	<u>COMMENT</u>
HOSPITALS: * MASSACHUSETTS GENERAL TUFTS MEDICAL CENTER HOLY CROSS (MD) RIVERSIDE (VA)	ADL ADL ORI BIONETICS	● LIFE CRITICAL EQUIPMENT PROTECTED BY HIGH EFFICIENCY AIR FILTERS
AIRPORT/AIR TRAFFIC CONTROL: * BOSTON LOGAN TOWER WASHINGTON NATL. BOSTON AREA CONTROL	ADL ORI ADL	● FLIGHT-CRITICAL EQUIPMENT IS WELL PROTECTED
AIRPORT SERVICES: PASSENGER AREAS (MASS) RESERVATION SYSTEM (MASS)	ADL ADL	● AIR CONDITIONING PROVIDES THE PROTECTION
AIRLINE OPERATIONS (MASS) HANGARS (MASS)	ADL ADL	● VULNERABLE ITEMS IDENTIFIED

* AREAS COMPLETED: NO FURTHER SURVEYS

Figure 1

SURVEYS COMPLETED

<u>LOCATIONS SURVEYED</u>	<u>BY</u>	<u>COMMENT</u>
TELEPHONE EXCHANGES: CENTRAL OFFICES (MD) MILITARY BASE (MD)	ORI BRL	● VULNERABLE ITEMS IDENTIFIED
POST OFFICE (MASS)	ADL	● SOME VULNERABLE ITEMS
TRAFFIC LIGHT CONTROL *	BIONETICS	● WELL PROTECTED
RADIO STATIONS (MASS)	ADL	● STUDIOS PROTECTED ● TRANSMITTERS, OPEN
MANUFACTURING INDUSTRY: DIGITAL ELECTRONICS (MASS) ELECTRONIC AND METAL MACHINING (VA) TELEVISION RECEIVERS ASSEMBLY (VA) LIGHT TRUCK ASSEMBLY (VA) TEXTILE FIBER (VA)	ADL BIONETICS ↓	● PROTECTED BY FILTERS ● INDUSTRIAL INSTALLATIONS SELECTED FOR AN IMPACT STUDY

Figure 2

all the pieces of equipment necessary to handle an airplane in the air have air conditioning with good filtration and in most cases, each item of equipment has a good enclosure or case.

The passenger areas of a terminal must control jet engine fumes. Each terminal handles the problem differently. Dallas - Ft. Worth uses positive pressure; Boston uses activated carbon. The surveys found air conditioning with extra filtration or some means that would tend to minimize the ingestion of carbon fibers. Reservation systems generally have open electronic equipment and depend upon the air conditioning system for protection.

Airline operations equipment includes the computers and the communication elements by which an airline schedules its airplanes, schedules its maintenance, and schedules its own internal operations. These functions receive their protection from air conditioning since most of the equipment tends to be open. Potentially vulnerable items have been identified and are candidates for test. Reviews of this particular area found power failure as the principal problem. Most have some kind of emergency power system; and Boston generally has to call on emergency power about four times a year. Hangars are open. In the servicing of aircraft, equipment can become exposed; however, sensitive pieces of equipment have protective covers which tend to minimize the ingestion of fibers. The lists have now defined those items which are open and do need testing.

For telephone exchanges (Figure 2), the other big user of electronics, the surveys included central offices and one military base. Here, the range of equipment runs from fairly old to the most modern of electronics. Some exchanges have better protection than others. The surveys have identified a composite list of potentially vulnerable equipment. Some of the patch boards and pass-through circuitry that the telephone company uses appear potentially quite sensitive. Some of that equipment finds its way into airport equipment rooms and control towers. In such a case, should the integrity of the tower be violated, it would probably be the telephone items in the ground communication equipment that would suffer first.

The post office uses digital equipment in cancelling and sorting mail. Some show reasonable protection; however, the facility surveyed had elevator shafts, roller doors, and windows such that fibers could enter. The impact would be a return to hand sorting if the equipment were down for an extended period of time.

Traffic light controllers show a similarity to telephone equipment; they range from simple items to sophisticated equipment. The combination of air flows, filtration and design features eliminates these items as a problem.

Radio stations have their studio areas divided into small rooms for isolation. This limits the ingestion of fibers; however, a fair amount of dust does get into the electronics. The field survey found one transmitter that was an open building; newer transmitters are moving away from open construction.

The digital electronics manufacturer protects the manufacturing areas by air filtration and operates the building at a positive pressure. Control computers are installed in a room-within-a-room. If they lost their air conditioning system and their air filtration, the economic impact would be the cost of cleaning any open equipment. At the present time, survey efforts are considered completed for hospitals, air traffic controls and traffic light controllers.

The last four industries were surveyed in detail to look at the possible effects of a fiber release incident. In addition to the general objectives which guided all the survey efforts, the impact study carried the three special objectives as listed in figure 3. This particular effort received cooperation and hospitality from four major industrial installations located in the Virginia - southeast area. The basis for their selection was diversity in product coupled with a dependence upon electrical equipment throughout the manufacturing sequences.

IMPACT STUDY - INTENT AND OBJECTIVES

A DETAIL IMPACT STUDY WOULD PROVIDE:

- | | |
|---------------------------------------------------------------------------------------------------|------------------------------------|
| (1) VERIFICATION OF DATA OBTAINED | - USEABLE DATA |
| (2) AN INITIAL SCOPING OF ANY POTENTIAL COST-RISK | - FIRST ESTIMATES |
| (3) IDENTIFICATION OF DATA IMPROVEMENTS
REQUIRED FOR AN ACCEPTABLY COMPLETE
COST-RISK VALUE | - DIRECTIONS FOR
FURTHER EFFORT |

INDUSTRIAL INSTALLATIONS STUDIED:

- (1) MANUFACTURE OF MACHINED METAL AND ELECTRONIC COMPONENTS
- (2) ASSEMBLY OF MONOCHROME AND COLOR TELEVISION RECEIVERS
- (3) ASSEMBLY OF LIGHT TRUCKS
- (4) MANUFACTURE OF SYNTHETIC TEXTILE FIBERS AND YARN

Figure 3

As listed in figure 4, the study used six steps to make the detailed estimate of impact. The first step was aimed at understanding what went on inside that factory. The second step sought out the vulnerable equipment and looked at what would happen in the event of a failure. The third step clothed the failure incidents with dollar costs. Step four drew from the information on ventilation to define transfer functions that would show the kind of barriers in the way of a carbon fiber entering the building. Step five became a scenario for a carbon fiber release incident plus the use of established mathematics to estimate a probability for failure. Step six multiplied the values from step five and step three to get the impact summary. This study is presently on-going, therefore one plant will serve as an example to show the method and then be compared to the other three.

Figures 5 and 6 illustrate Step 1. These diagrams show a modern factory powered by four large transformers. All four work together in one room. The factory operates three independent lines with each line producing one component. The electronic component is sophisticated; the line has all the classical elements of a modern electronic fabrication facility. They make their own circuit boards and use numerical controlled equipment to drill the holes in the circuit boards. The circuit assembly process uses automated techniques; digital controlled devices place the resistors and capacitors into the circuit boards; and hand stuffing completes the

IMPACT STUDY METHOD AND EXAMPLES

THE STUDY REQUIRED 6 STEPS TO GENERATE IMPACT PRODUCTS

1. DIAGRAM THE FACTORY IN TERMS OF: PRODUCT FLOW; VULNERABLE EQUIPMENT; AND IN-PLACE PROTECTIONS.
2. IDENTIFY POTENTIALLY VULNERABLE ITEMS OF EQUIPMENT IN TERMS OF: IMPACT OF A FIBER-INDUCED FAILURE; AND THE KINDS OF LOSSES WHICH COULD OCCUR.
3. ESTIMATE THE POTENTIAL COST ASSOCIATED WITH EACH POTENTIAL FAILURE.
4. ESTIMATE AN EXPOSURE TRANSFER FUNCTION FOR EACH ITEM OF EQUIPMENT.
5. ESTIMATE THE PROBABILITY FOR SUCH A FAILURE BASED UPON A DEFINED RELEASE INCIDENT AND BEST VALUES FOR \bar{E} .
6. CALCULATE THE IMPACT PRODUCTS (PROBABILITY X COST ESTIMATE)

Figure 4

IMPACT STUDY METHOD AND EXAMPLE

STEP 1, VULNERABILITY CONSIDERATIONS FOR A METAL MACHINING AND ELECTRONIC COMPONENT FACTORY.

POWER SUPPLY: 4 AIR-COOLED TRANSFORMERS LOCATED IN ONE ROOM

ELECTRONIC COMPONENT LINE:

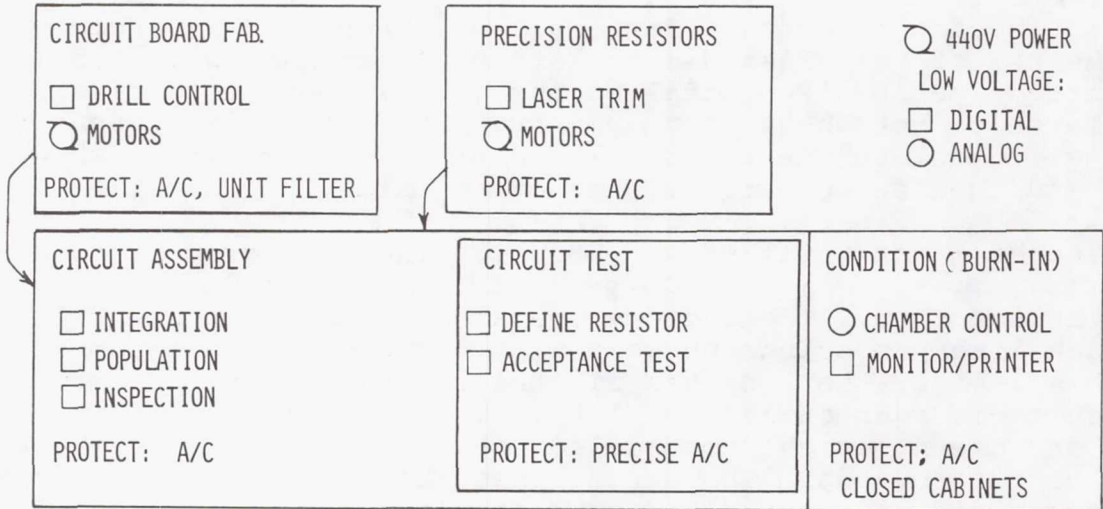
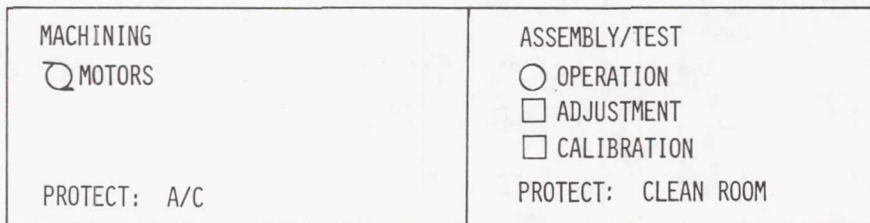

Figure 5

IMPACT STUDY METHOD AND EXAMPLE

STEP 1, CONT'D VULNERABILITY CONSIDERATIONS

PRECISION MACHINING LINE:



AUTOMATED MACHINING LINE:

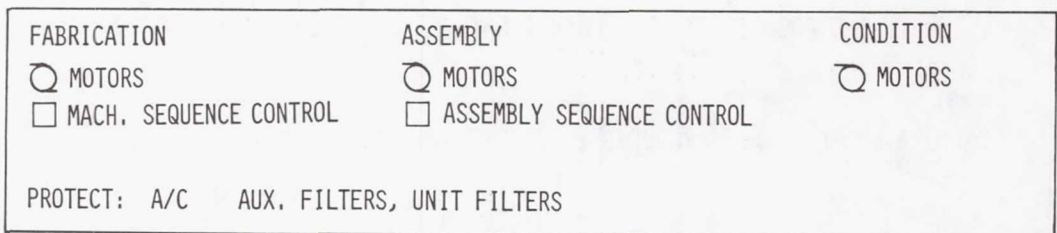

Figure 6

population. Digital equipment performs inspection sequences. This particular circuit is balanced by very precise, laser trimmed resistors. The values of the resistors are defined using digital equipment; the resistors are trimmed using digital equipment. The assembled units are conditioned by a thermal cycle burn-in as with any high quality electronic component.

In assessing vulnerability, the electronic component has coated circuit boards and is not considered vulnerable. The electronic equipment depends upon air conditioning filters and cabinet filters for protection. Therefore the electronic component line and the air cooled transformers show a degree of vulnerability.

Figure 6 diagrams the other two lines, one is a machining line for an electromechanical unit built to close tolerance. The machining is done in a separated area and the equipment operates in the spray from the cutting fluids. Assembly has to be done under very closely controlled environmental conditions. This particular unit has to be operated, adjusted, and calibrated, all using digital test equipment. On the automated machining line, computers do the sequencing and controlling of the steps during both machining and assembly. In looking at the kinds of protections, the computers in the automated line are also working in the spray from the cutting machines or in the dust from the lubricants used during assembly. Filters which remove mist or stray lubricant will not pass fibers. The filtration within clean rooms employs HEPA type filters which do not pass fibers. These two lines do not show a vulnerability to fibers.

The comparison to the other three factories must consider the diversity intended in the selection for product and mode of operations. Figure 7 compares the characteristics of the four factories.

The assembly of televisions included a limited amount of fabrication, mostly plastic molding, together with a number of moving belt assembly lines. Each television chassis size has a dedicated assembly line which can accommodate different cabinetry and different small features from set to set. The assembly of light trucks employs one large integrated line which can accommodate every option that can go into a pickup truck from vehicle to vehicle. The production of textile fibers requires a dedicated line which runs continuously seven days a week around the clock. This plant has another product, nylon with a conductive carbon coat. This material is used for control of static electricity in carpets.

In comparing the factories, the first two are "all under one roof" type of operations. The truck assembly plant is about 50 years old and has a main assembly building plus warehouses and a separate building to house the air compressors and steam boilers. The fiber producer employs separate buildings for processing lines, for spinning of yarn and for the coating of nylon.

IMPACT STUDY

COMPARISON OF INDUSTRIAL INSTALLATIONS: CHARACTERISTICS

	MACHINING ELECTRONIC	ELECTRONIC ASSEMBLY	AUTOMOTIVE ASSEMBLY	TEXTILE FIBER
<u>PRODUCT</u>	<ul style="list-style-type: none"> • 3 AUTOMOTIVE COMPONENTS 	<ul style="list-style-type: none"> • TV RECEIVERS (BLACK/WHITE AND COLOR) 	<ul style="list-style-type: none"> • LIGHT TRUCKS 	<ul style="list-style-type: none"> • ACRYLICS • CONDUCTIVE-COATED NYLON
<u>HOW PRODUCED</u>	<ul style="list-style-type: none"> • FABRICATION AND ASSEMBLY IN DEDICATED LINES • IDENTICAL UNITS 	<ul style="list-style-type: none"> • LIMITED FABRICATION PLUS ASSEMBLY • NUMBER OF MOVING-BELT LINES, SET BY CHASSIS (~ TUBE SIZE) 	<ul style="list-style-type: none"> • INTEGRATED MOVING-BELT ASSEMBLY LINE • UNITS DEFINED INDIVIDUALLY 	<ul style="list-style-type: none"> • DEDICATED LINES FOR EACH TYPE FIBER • CONTINUOUS OPERATION
<u>FACTORY</u>	1 BUILDING	1 BUILDING	1 BUILDING PLUS	MULTIPLE BUILDINGS

Figure 7

Figure 8 compares some of the pertinent features of the four industrial installations. The power systems showed both points of diversity and elements of commonality. Transformers were located in different places, many of them indoors, some clustered together, some of them outdoors; and they employed different means for cooling; but there was one commonality. All installations used a 13.2 kV inlet, all had air cooled high voltage switches. In the case of the television factory, the cooling was secondary air flowing around sealed cases. The automotive plant and the fiber plant had the air cooled switches enclosed in outdoor type cabinets, louvered inlets, vents at the top of the case, over-hanging roof for rain protection. Outside air circulates through this type of cabinet.

The 440 volt power equipment showed a diversity which reflected the product of the plant. The television plant has to heat plastics, the automotive plant has to weld, the fiber plant has to control the speeds of the line. They achieve control by driving a motor generator to produce a variable frequency. Variable frequency 440 volt induction motors along the line will then all run in step.

440 volt motors appear as the common denominator for all industry. They are running in the spray and mist of a machining operation; they are hanging from the ceilings to drive an overhead conveyor; they are buried under the floors to drive moving

IMPACT STUDY

COMPARISON OF INDUSTRY INSTALLATIONS: FEATURES

FEATURES	MACHINING ELECTRONIC	ELECTRONIC ASSEMBLY	AUTOMOTIVE ASSEMBLY	TEXTILE FIBER
<u>POWER SYS.</u>	4 TRANSFORMERS 1 LOCATION INDOORS	16 TRANSFORMERS 6 LOCATIONS INDOORS	9 TRANSFORMERS 9 LOCATIONS MOSTLY INDOORS	9 TRANSFORMERS 9 LOCATIONS OUTDOORS
<u>COOLING:</u> TRANSFORMER SWITCH CT. BKRS.	AIR AIR AIR	OIL AIR AIR	OIL AIR AIR	OIL AIR AIR
440V POWER MAJOR USE	● MOTORS	● MOTORS ● HEATERS	● MOTORS ● WELDERS	● MOTORS ● FREQUENCY CONVERTER
<u>BUILDING</u> VENTILATION	AIR COND.	AIR COND.	● WINDOWS ● HEATERS	MOSTLY OPEN
FILTERS	ALL AIR	RECIRCULATE	PAINT AREA ONLY	NONE

Figure 8

belt conveyors; and they are mounted over chemical vats to drive process lines. At the present time, tests have shown that 110 volt motors are not a problem, and 220 volt motors should be the same. However, 440 volts is in the range which can create a sustaining arc; and considering the wide usage, the vulnerability of 440 volt motors must be defined by test.

The ventilation systems reflect the needs of the product. Precision assembly and the fabrication of electronics benefit from closed buildings with filtered air conditioning. The assembly of automobiles has a dust-critical operation during spray painting. The heat and vapors from a chemical process dissipate more readily from an open building.

Figures 9 and 10 illustrate Step 2 which employs an adaptation of the fault tree concept. This step first identifies any possibly vulnerable item of equipment and then describes what would happen in the event of a fiber induced failure. The results of the failure are then presented in terms which would permit establishing a cost.

For instance if a power transformer were to fail, it would probably stop some of the lines, but offices would not go dark and the maintenance people could work. In such a case, the considerations would become: Would it be necessary to furlough people?

IMPACT STUDY METHOD AND EXAMPLE

STEP 2, IMPACT SUMMARY

EQUIPMENT ITEM	MAIN TRANSFORMER (13.2KV SUPPLY)	DRILL CONTROL	LASER TRIM
IMPACT; FIBER- INDUCED FAILURE	HALT MANUFACTURE	STOP OPERATION SPOILED BATCH	STOP OPERATION SPOILED UNITS
LOSS CONSIDERATIONS	WORK FORCE TIME LOST PRODUCT START UP RECOVER SCHEDULES	SPOILED BATCH TROUBLESHOOT LOST TIME STARVED LINE	SPOILED UNIT TROUBLESHOOT LOST TIME STARVED LINE

Figure 9

IMPACT STUDY METHOD AND EXAMPLE

STEP 2, CONT'D IMPACT SUMMARY

EQUIPMENT ITEM	INTEGRATOR POPULATOR INSPECTION	RESISTOR DEF. ACCEPTANCE MONITOR	CHAMBER CONTROL
IMPACT; FIBER- INDUCED FAILURE	REDUCED CAPABILITY SPOILED UNITS	REDUCED CAPABILITY PRODUCT DELAY	DELAY SPOILED BATCH
LOSS CONSIDERATIONS	SPOILAGE TROUBLESHOOT LOST TIME DELIVERY RATE	TROUBLESHOOT RE-TEST LOST TIME DELIVERY RATE	SPOILED BATCH TROUBLESHOOT RE-TEST DELIVERY RATE

Figure 10

Would machine stoppage spoil product? Would start-up require clearing the machines and reprogramming some computers? And, finally, in the case of a plant which supplies another assembly line, would they have to recover their schedule?

For some of the other items (Figure 10), the situation is a little different. The considerations include spoiled batches and the time required to trouble shoot or repair; meanwhile there would be lost time for the operators. A prolonged down time of a piece of equipment could starve the rest of the assembly line or at least reduce the capability for production.

Figure 11 compares the potentially vulnerable equipment within the four factories. For power, the common use of air cooled switches both indoors and outdoors appears vulnerable. For the 440 volt equipment, some work reported by the Navy has shown that 440 volt buses with air ventilation can create a sustaining arc and burn up; a similar situation may exist in large 440 volt motors with open windings. In the textile fiber plant, the frequency converter appears potentially vulnerable.

For low voltage analog types of equipment, the vulnerability of temperature controllers has been recognized. The television plant has two areas of concern. A television set has to be aligned and tuned to the frequencies of the commercial stations. This requires

IMPACT STUDY

COMPARISON OF INDUSTRY INSTALLATIONS: POTENTIALLY VULNERABLE EQUIPMENT

ELEMENT	MACHINING ELECTRONIC	ELECTRONIC ASSEMBLY	AUTOMOTIVE ASSEMBLY	TEXTILE FIBER
POWER	AIR-COOLED SWITCHES		AIR-COOLED SWITCHES	OUTDOOR SWITCHES
440V EQUIPMENT			<ul style="list-style-type: none"> ● VENTILATED BUS ● OPEN WINDINGS 	FREQUENCY CONVERTER
LOW VOLTAGES ANALOG	TEMPERATURE CONTROLLER	<ul style="list-style-type: none"> ● TEST SIGNAL SYSTEM ● TV RECEIVERS 	WELD TIMERS	TEMPERATURE CONTROLLER
LOW VOLTAGE DIGITAL	<ul style="list-style-type: none"> ● DRILLS ● TRIMMERS ● INTEGRATORS ● POPULATORS ● TEST STATIONS 	<ul style="list-style-type: none"> ● INTEGRATOR ● POPULATOR 	<ul style="list-style-type: none"> ● WELDER UNITS ● TELETYPE PRINTERS 	

Figure 11

an oscillator to generate the test signals and circuitry to support operations on the assembly lines. At any time during assembly, a number of television sets operate with their cases open; under such conditions there is some vulnerable product. The assembly of automotive sheet metal relies on spot welding; the welding timers operate exposed with uncoated circuit boards. These units must be considered vulnerable.

Low voltage digital equipment has an identified vulnerability. The automotive industry appears to be expanding the use of digital controlled robotic manipulators within the welding operations. In addition, teletype printer stations throughout the factory provide the means for achieving integration across the entire assembly process.

Figure 12 compares the potential impact of a fiber induced failure within types of vulnerable equipment. The failure of a power switch would halt manufacturing in one plant, halt assembly in another and, in the textile plant, it would shut down one or more lines. The 440 volt equipment has the same capability for impact. Low voltage equipment does not show quite the potential for impact; however, line stoppage is still a significant expense.

IMPACT STUDY

COMPARISON OF POTENTIAL FOR IMPACT

POTENTIAL FAILURE OF	MACHINING ELECTRONIC	ELECTRONIC ASSEMBLY	AUTOMOTIVE ASSEMBLY	TEXTILE FIBER
POWER: TRANSFORMER OR SWITCH	HALT MANUFACTURE	-	HALT ASSEMBLY	STOPS ONE OR MORE LINES
440 VOLT EQUIPMENT	-	-	HALT ASSEMBLY	STOPS LINE
LOW VOLTAGE ANALOG	SLOWS PRODUCTION	SHORT-TERM LINE STOP	SHORT-TERM LINE STOP	SLOWS PRODUCTION
LOW VOLTAGE DIGITAL	SHORT-TERM LINE STOP	SLOWS PRODUCTION	SLOWS PRODUCTION	-

Figure 12

As shown in figure 13, the first step in the estimation of a cost requires defining how a factory would respond to a failure; and there seemed to be no common way these factories would respond. The factory supplying another assembly line would probably have to recover the delivery schedules. A factory that maintained an inventory supply may elect to defer any catch-up of production. A continuous operating plant does not have much flexibility for improving delivery or recovering lost production. The loss terms were converted to costs expressed as lost labor hours, number of product lost, and estimates of materials involved. The conversion to dollars used data that came from such sources as Chamber of Commerce publications, Industrial Association publications and to the extent practical, data from the Bureau of the Census. A national estimate for an economic impact on industry must find a way to use census data.

As shown in figure 14, the transfer function took the simplest practical approach. The A. D. Little Company, during previous work, had devised an equation for the transfer function based on filter efficiencies and the relative ventilation flow rates throughout the factory. This equation was considered adequate for the purposes of this study. The transfer function appears as a product with one term which describes the factory and the other term which describes the cabinet that houses the electronics.

IMPACT STUDY METHOD AND EXAMPLES

STEP 3, ESTIMATION OF A COST

- DEFINE AN APPROPRIATE RESPONSE-TO-FAILURE ACTION.
- ESTIMATE THE CORRESPONDING IMPACT FOR EACH ITEM OF EQUIPMENT AND EACH LOSS CONSIDERATION IN TERMS OF: LABOR HOURS; PRODUCT; MATERIALS.
- CONVERT TO DOLLARS USING AVAILABLE PUBLISHED DATA.

Figure 13

STEP 4, TRANSFER FUNCTION, ASSUMPTIONS:

- ACCEPT THE ADL EQUATION BASED UPON VENTILATION PARAMETERS AND FILTER EFFICIENCIES.

$$\text{TRANSFER FUNCTION} = \left(\frac{Q + (1 - N_I) \frac{M}{R}}{Q + M + N_R \frac{M}{R}} \right) (1 - N_C)$$

RELATIVE FLOW RATES:

Q = INFILTRATION
M = MAKE UP
R = RECIRCULATION

FILTER EFFICIENCIES:

N_I INLET FILTER
N_R RECIRCULATION FILTER
N_C CABINET FILTER

- ASHRAE DUST SPOT EFFICIENCIES CORRELATE TO FIBER EFFICIENCIES:

ASHRAE %	FIBER %	ASHRAE %	FIBER %
10-35	90	45-80	98.5
35-40	97	80-90	99
40-45	98		

Figure 14

Other work reported by the A. D. Little Company indicated that air conditioning filters showed a correlation between the efficiency for stopping fibers and the efficiency as rated by the ASHRAE dust spot method. As interpolated from the published data, the values shown represent the efficiencies for removing fibers as correlations to the efficiencies measured by dust spot ratings. The assumption is limited to just those kinds of filter materials used in industrial installations.

Figure 15 outlines the assumptions used to calculate the probability for a failure. The equation shown assumes the failure is precipitated by a single fiber. The values selected for \bar{E} become the best estimates extracted from existing test data. The outside exposure of 10^5 fiber seconds per cubic meter represents an estimate for a median fiber release incident.

Figure 16 shows the kinds of results appearing after preliminary calculations. Relative to the transfer functions, the value shown for the transformer/13 kV switch represents the basic air conditioning system. The populator has air conditioning plus a cabinet filter. Acceptance test represents a room-within-a-room with precise temperature control. The chamber control reflects air conditioning plus a tight cabinet.

IMPACT STUDY METHOD AND EXAMPLE

STEP 5 ESTIMATE A PROBABILITY FOR FAILURE

- PROBABILITY OF FAILURE = $1 - e^{-E_i/\bar{E}}$

E_i = EXPOSURE

\bar{E} = AVERAGE EXPOSURE TO CAUSE A FAILURE (TEST DATA)

- ASSUME A FIBER RELEASE INCIDENT RESULTING IN AN OUTSIDE EXPOSURE OF 10^5

THEN, $E_i = T.F (10^5)$

STEP 6 IMPACT PRODUCT

(PROBABILITY) X (COST ESTIMATE)

Figure 15

IMPACT STUDY METHOD AND EXAMPLE

CALCULATION ASSUMING AN EXPOSURE OF 10^5

<u>ELEMENT</u>	<u>TRANSFER FUNCTION</u>	<u>\bar{E}</u>	<u>PROBABILITY OF FAILURE</u>	<u>FAILURE EST. COST</u>	<u>IMPACT PRODUCT</u>
TRANSFORMER (13 KV SWITCH)	3.2×10^{-2}	10^5	6.4×10^{-2}	$\$ 8 \times 10^4$	$\$ 5.2 \times 10^3$
POPULATOR (COMPUTER)	3.0×10^{-4}	10^6	1.2×10^{-4}	$\$ 4 \times 10^2$	$\$ 4.9 \times 10^{-2}$
ACCEPTANCE TEST	2.2×10^{-5}	10^6	1.4×10^{-5}	$\$ 4 \times 10^2$	$\$ 5.5 \times 10^{-3}$
CHAMBER CONTROL	6.2×10^{-4}	10^7	6.2×10^{-6}	$\$ 4 \times 10^4$	$\$ 2.5 \times 10^{-1}$

Figure 16

For the \bar{E} values listed, the chamber control reflects a general knowledge of typical units. The 10^6 values correlate to test results on typical computers employed in such installations. The value listed for the transformer/13 kV switch is an engineering estimate. The values shown for the probability of failure include the effects of a multiple installation where a failure in any one unit could produce the estimated cost.

In assessing costs, clearing a failure within a computer does not incur a large penalty particularly if companion units do not fail (only one failure in a group). Loss of a half day of production during a thermal excursion has a significant cost impact. A power failure which halts manufacture has a major impact.

The consequence of a power failure persists into the impact product and result in the only significant value. The costs associated with a half day of production are offset by the low probability for a chamber control failure to cause a thermal runaway.

The findings from the study as listed in figure 17 show that failures within power equipment have the potential for causing the kinds of economic impact associated with the shut-down of a factory. Low voltage equipment can fail and cause a significant economic impact such as loss of a half days production. Fortunately, the

IMPACT STUDY FINDINGS

OBSERVATIONS FROM THE STUDY:

POWER: ONLY FAILURES WITHIN POWER EQUIPMENT SHOW A POTENTIAL FOR MAJOR ECONOMIC IMPACT.

LOW WIDE USAGE IN IMPORTANT APPLICATIONS.

VOLTAGE: FAILURES COULD HAVE SIGNIFICANT ECONOMIC IMPACT.

PROTECTIONS: FILTERS AND CABINETS IN-USE APPEAR TO PROVIDE ORDERS-OF-MAGNITUDE BUFFERING.

Figure 17

present protections of air conditioning and good cabinets moderate any chances for failure.

Figure 18 summarizes the results from the surveys relative to further effort. The areas of hospitals and air traffic control do not seem to have a problem. For other essential service equipment, the surveys have generated candidate lists of items for test. Industry cost modeling requires more data. Future work must look at high voltage and 440 volt equipment first. Test data must include a wider range of filter media, since industry uses a correspondingly wide range. There is a need for a correlation to other economic data such as provided by the Bureau of the Census. Therefore, surveys must continue toward developing a method for relating to the bulk of federal data. The DOE has a test plan to evaluate high voltage equipment and requires the coordinating of information such that areas of concern do receive evaluation by test. Finally the current test program for vulnerability and for filter transfer will require a continuing liaison toward updating candidate lists in the light of new data.

CONCLUSIONS AND RESULTS FROM THE SURVEYS
APPLIED TO FUTURE COST RISK ASSESSMENT EFFORTS

1. HOSPITAL AND AIR TRAFFIC CONTROL EQUIPMENT APPEAR TO HAVE GOOD PROTECTION.
2. SURVEYS OF ESSENTIAL SERVICE EQUIPMENT HAVE IDENTIFIED POTENTIALLY VULNERABLE ITEMS.
3. COST IMPACT MODELING FOR INDUSTRY NOT COMPLETE; DATA FROM SURVEYS AND TESTS NEEDED TO:
 - DEFINE VULNERABILITIES OF HIGH VOLTAGE AND 440 V EQUIPMENT
 - CHARACTERIZE FILTER EFFICIENCIES AND TRANSFER FUNCTIONS
 - ESTABLISH A CORRELATION TO OTHER ECONOMIC DATA
4. ACTIONS INDICATED:
 - PLAN AND CONDUCT ADDITIONAL SURVEYS
 - COORDINATE WITH DOE IN THE TEST PLANNING FOR HIGH VOLTAGE EQUIPMENT
 - EVALUATE RESULTS FROM ON GOING TESTS

Figure 18

Pertinent Questions and Answers

(1) Question:

Have any surveys looked at nuclear or other electrical generating stations for effects on control rooms or vulnerable equipment?

Answer:

No visits have been made to any electric power plants; the DOE is charged with that responsibility. In a review of the requirements for nuclear plants, their specifications consider seismic effects, and they also require the capability to seal the control rooms such that they become self-sustaining entities in the event of an emergency. Control of power plants does not appear as a problem.

There is no definitive data to show what happens when fibers get into an area that is concentration critical, here the presence of fibers can distort the electric field. These effects are part of the reasoning behind the DOE test program. There has been some work done by BRL, by the Navy, and by other agencies; they have identified the principal areas of uncertainty.

(2) Question:

What did the airport surveys find for landing aids such as glideslope transmitters and similar equipment?

Answer:

These items are usually located out along the runways in a sealed building or at least with filtered air. The electronics are mounted in closed or sealed cases. They do not appear as a problem.

RISK METHODOLOGY OVERVIEW

Karen R. Credeur
NASA Langley Research Center

Figure 1 gives the agenda for the risk methodology overview. Before talking specifically about the carbon fiber risk methodology, I'd like to talk about risk methodology in general. We'll talk about some considerations of risk estimation, how risk is measured, and how risk analysis decisions are made. We'll then turn to the specific problem of carbon fiber release where I will review the objective, describe the main elements, and give an example of the risk logic and outputs.

RISK ANALYSIS CONTENT

- GENERAL
 - ESTIMATION
 - MEASUREMENT
 - DECISION

- SPECIFIC
 - OBJECTIVE
 - ELEMENTS
 - EXAMPLE
 - LOGIC
 - OUTPUTS

Figure 1

Risk estimation involves a number of considerations, as outlined in figure 2. Among these are the objective, the elements of the individual problem, the methods that are used, and how those methods are chosen and tested. Another consideration is whether the methods used are analytic or approximate; under "approximate" we're particularly interested in whether simulation is used. We are also concerned with what assumptions are made. For example, are all filters properly installed? How much carbon fiber is carried and by what types of planes? What kind of electronics will be used in 1993? Another component of risk estimation is scope. Under scope we are interested in both micro and macro

RISK ESTIMATION

- OBJECTIVE
- ELEMENTS
- METHODS
- ASSUMPTIONS
- SCOPE: MICRO, MACRO, LIMITS
- ERRORS
- SENSITIVITY STUDIES
- WORST CASES

Figure 2

analysis. "Micro" and "macro" are used here as economic terms and mean "bottom up" and "top down," respectively. Micro refers to the details of the problem whereas macro refers more to an overview. Mr. Ansel Butterfield gave a good example of a micro analysis when he talked about the costing of industrial plants. An example of a macro analysis would be trying to cost a power outage resulting from the carbon fiber problem by using costs of power outages resulting from non carbon-fiber problems. Part of scope are the limits of the risk analysis. Limits are closely tied with assumptions. Two limits, for example, in the carbon fiber study are restriction to just the commercial part of civil aviation and to just single fibers.

A major consideration in risk estimation is errors. Errors are involved in the elements, methods, assumptions, and scope. How these errors are defined and presented are two important parts of the problem. Sensitivity studies show how variations in the elements affect the risk; in particular, they indicate which of the elements are the main contributors to the risk. A sensitivity study is done by varying only one parameter, or perhaps one group of the parameters, while holding all other elements fixed and recalculating the risk for each variation of the parameter. Worst cases are usually important to present. Furthermore, if, as in

most risk analyses concerning rare events, simulation forms the basis of the methodology, the worst cases might not be obtained among the simulated cases and, hence, must be calculated separately.

Figure 3 gives the units and format for risk measurement. The usual units are fatalities, injuries, dollars and complaints. As Mr. Heldenfels noted in his talk, fatalities and injuries are usually the most important units. However, as he also pointed out, they don't seem to be an issue in this problem. Complaints can't be ignored even though the dollars are small, and there are no fatalities or injuries. Because nearly all risk analyses involve probabilities which range from 0 to 1, the main output is in terms of a curve instead of a point. Two types of curves that are commonly used are what are called density and cumulative curves and I will be giving examples of these later. Even though the main result is a curve it is usually important to have one or more summary measures. Some of the typical types of summary measures are means, medians, modes, extremes, and various combinations of these four. Again, error bounds are usually important in any type of risk analysis, and they can be shown in various ways.

RISK MEASUREMENT

UNITS:

- FATALITIES
- INJURIES
- DOLLARS
- COMPLAINTS

FORMAT:

- CURVE: DENSITY, CUMULATIVE
- POINT: MEAN, MEDIAN, MODE, EXTREME, OTHERS
- ERROR BOUNDS

Figure 3

The main elements of risk decision are given in figure 4. The first job in decision making is defining the decision maker. Sometimes he is not specifically defined. Sometimes the decision maker is a body of people. The second job is determining the measures that are important to the decision maker. These measures, or acceptability criteria, vary with the problem and with the decision maker. The first acceptability criterion usually concerns the actual values. If the risk curves have many extremely large values or all very small values, the remaining acceptability criteria may not be important. Under "actual value" one is concerned with whether the value is direct or indirect. An example of a direct cost in the carbon fiber problem is equipment replacement and repair. An example of an indirect cost would be product loss, as Mr. Butterfield illustrated, resulting from equipment that has malfunctioned because of the carbon fiber problem.

RISK DECISION

- DECISION MAKER
- ACCEPTABILITY CRITERIA (VARIES WITH PROBLEM AND DECISION MAKER)
 - ACTUAL VALUE
 - DIRECT VERSUS INDIRECT
 - COMPARISON WITH OTHER RISKS
 - VOLUNTARY VERSUS INVOLUNTARY
 - COMPARISON WITH BENEFITS

Figure 4

Once we have analyzed the actual risk values, we are then interested in comparing these values with those from other types of risk. For example, how does the probability of failure to a stereo from the carbon fiber problem compare with the probability of failure to a stereo from all other causes. How does the carbon-fiber risk compare with other types of risk, for example, risks from floods, tornadoes, driving, and private flying. In making risk comparisons, two concerns are voluntary risk versus

involuntary risk. Voluntary risk is risk a person imposes upon himself. Involuntary risk is risk imposed upon the person. Examples of voluntary risk are flying a private plane and driving an automobile. Involuntary risk is exemplified by being a passenger in a commercial airplane. Needless to say, people are much more willing to accept voluntary risk than they are involuntary risk. We are also interested in comparing risk with benefits in terms of the curves and summary statistics. If the benefits greatly outweigh the risks, then the decision maker leans toward acceptance of the risk. However, a benefit-risk comparison is never the sole criterion for decision making. If, for example, a program would have huge benefits but is such that there would be a high probability of destroying two cities, the program would not be accepted.

Figure 5 gives an example of a risk comparison. This figure, which is called a risk profile, comes from a risk analysis of the operation of water-cooled nuclear power plants in the United States. This nuclear reactor safety study was commissioned by the United States Atomic Energy Commission and directed by Dr. Norman C. Rasmussen of M.I.T. The vertical axis gives the number of events per year exceeding various dollar damages that are shown on the horizontal axis. The curve for natural events is dominated by hurricanes. The second main contributor is tornadoes. The main component of the man-caused events is huge fires. Among other events are mine disasters and industrial explosions. The "100

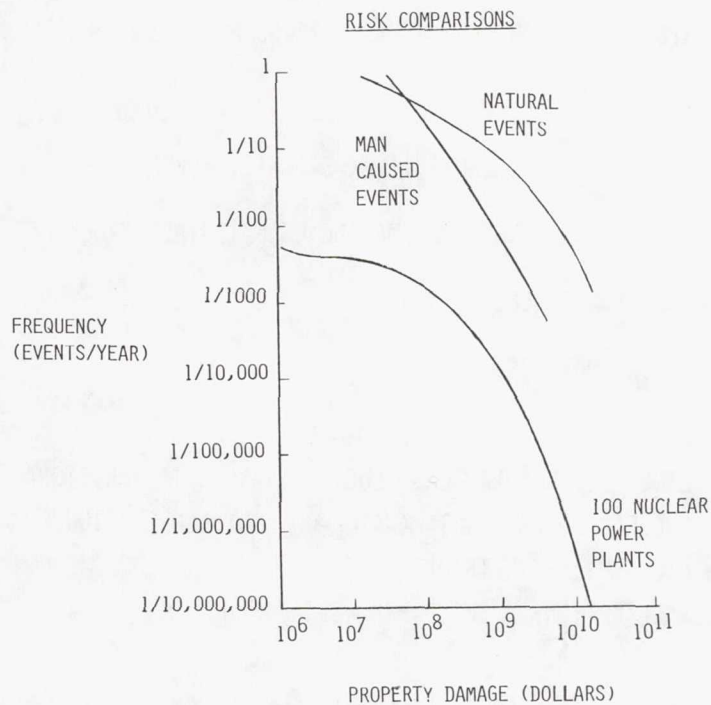

Figure 5

nuclear power plants" means that the nuclear-plant population considered consists of 100 plants, rather than just one plant. That is, if the probability of one accident at one plant is "x", then the probability of one accident out of a population of 100 plants is 100 times "x".

The plot indicates that the damage from both at least one natural event, such as a hurricane, and one man-caused event, such as a large fire, can be expected to exceed \$10 million once every year and \$10 billion once every 1000 years. Equivalent damage from nuclear reactor accidents occurring within a population of 100 nuclear plants is expected to happen much less frequently. Note that automobile accidents, which had about \$15 billion in property damage when the three curves were constructed, were not included in the man-caused events. In a subsequent talk Dr. Joseph Fiksel of Arthur D. Little will compare the current risk profile for the carbon-fiber problem with the risk profiles shown in figure 5.

As you heard previously, and as shown in figure 6, the first objective of the carbon fiber risk analysis is to estimate the risk to the nation over the next 15 years from the use of carbon fiber in civil aircraft. The methodology is a logical, systematic analysis that strives to reduce the subjectivity of the risk

CARBON FIBER RISK ANALYSIS OBJECTIVES

- ESTIMATE RISK TO NATION OVER NEXT 15 YEARS FROM USE OF CARBON FIBER IN
CIVIL AIRCRAFT
 - REDUCE SUBJECTIVITY (ESTIMATE, ERRORS)
- PROVIDE FRAMEWORK FOR DECISION MAKING ON MATERIAL USAGE, MODIFICATION, AND
PROTECTION SCHEMES

NOTE: OTHER RISK ANALYSIS:

- AUTOMOBILES: SEAT BELT USAGE
- LIQUIFIED NATURAL GAS (LNG): TRANSPORTATION, STORAGE
- NUCLEAR POWER PLANTS (WATER-COOLED): OPERATION
- OIL (SPILLS): TRANSPORTATION
- VACCINATIONS: SMALL POX, SWINE FLU

Figure 6

estimate and of the errors associated with that estimate. The second objective is to provide a framework for decision making on material usage, material modification, and protection schemes. Note that other risk analyses have parallel objectives. Some of the more recent risk analyses are usage of seat belts in automobiles, transportation and storage of liquified natural gas (LNG), operation of water-cooled nuclear power plants - the study we just discussed for figure 5, comparison of transportation methods for oil so that spills are minimized, and mass vaccinations for the public; smallpox and swine flu being two examples.

As shown in figure 7, the carbon-fiber risk-analysis elements can be described in terms of three levels. The first is the local level, which is some type of geographic subdivision of the United States. The second is the national level, given that you have an estimate of the risk on the local levels. The third level involves extrapolating the risk estimate from the national level into the future. As noted in a previous paper, we're using the next fifteen years 1978-1993 as the future. As you also heard previously, some of the main elements on the local level are aircraft accident probability, dispersion of carbon fiber, transfer function, vulnerability, and costing. On the national level some of the main elements are number of accidents per year and the location of these accidents. Among considerations for location are whether the accident sites are near mountains or large bodies of water and

CARBON FIBER RISK ANALYSIS ELEMENTS

LOCAL:

- AIRCRAFT ACCIDENT PROBABILITY
- DISPERSION OF CARBON FIBER
- TRANSFER FUNCTION
- VULNERABILITY
- COSTING

NATIONAL:

- NUMBER OF ACCIDENTS PER YEAR
- LOCATION OF ACCIDENTS

FUTURE (1978-1993):

- CARBON-FIBER USAGE PROJECTIONS
- ACCIDENT STATISTICS CHANGES
- TECHNOLOGY CHANGES

Figure 7

what the population and electronic densities are. Some of the main elements on the future level are carbon fiber usage projections, accident statistics changes, and technology changes.

The next three figures are sequential illustrations of the logic for generating damage from an accident involving fire. This logic is an example of what is called an event tree or a decision tree. All our risk methodologists use some type of event tree like this one, although of much greater complexity and not necessarily in the sequence shown. Although this is a very simplified tree compared to what is actually used, at least one representation of each of the main elements of the carbon-fiber problem is included. The elements of the risk assessment under evaluation are identified across the bottom of the next three figures, that is: accident probability, source, dispersion transfer function, vulnerability, and costing. Across the top of the three figures are the data sources for these various elements: operation rates, accident records, weather records, census maps, experiments, surveys, and pathfinder studies. Calculations are made at each of the nodes. Some calculations involve analytic models; others, random selections.

The first node, shown in figure 8, represents the occurrence of an accident involving fire. The second node represents the choice of the location for the accident. Air traffic in the United States can be represented by the traffic at the 26 large

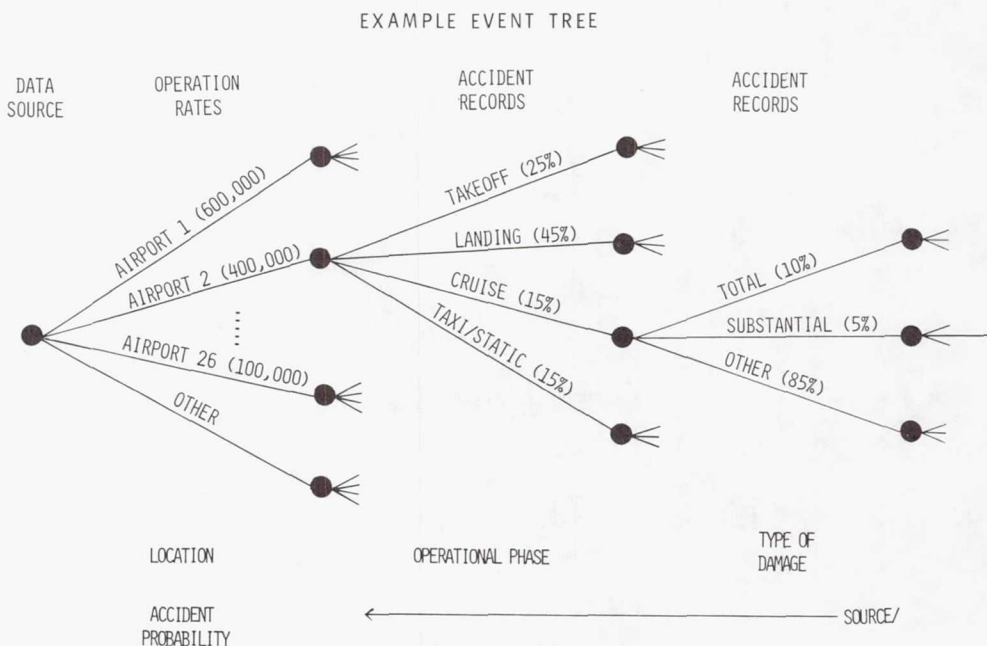

Figure 8

hub airports with everything else lumped into all "other." The number in parenthesis approximately gives the number of operations per airport. The airport selection is made by a random selection process. This selection process can be illustrated in the choice of the operational phase. Accident records show that fire accidents occur 25% of the time in take-off; 45%, in landing; 15%, in cruise; and 15% in static or taxi operation. The selection of the operational phase can be illustrated by use of a roulette wheel. Moving clockwise, assign the first 25% of the roulette wheel to take-off; assign the next 45% to landing; the next 15% to cruise; and the last 15% to taxi/static. The roulette wheel is therefore divided into four areas with proportions corresponding to the probability of an accident in take-off, landing, cruise, and static or taxi operation. For this example, a spin of the roulette wheel selects "cruise" as the operational phase. Although this is a very simple example, all random simulations are performed in a similar manner. The next node selects the type of damage. The type of damage determines, in part, the amount of fiber released. In this example "substantial" is selected using the random process based on statistics from accident records.

A similar random selection process is used to select the size of an aircraft, which affects source. The three aircraft size categories are shown in figure 9. The probability of an explosion

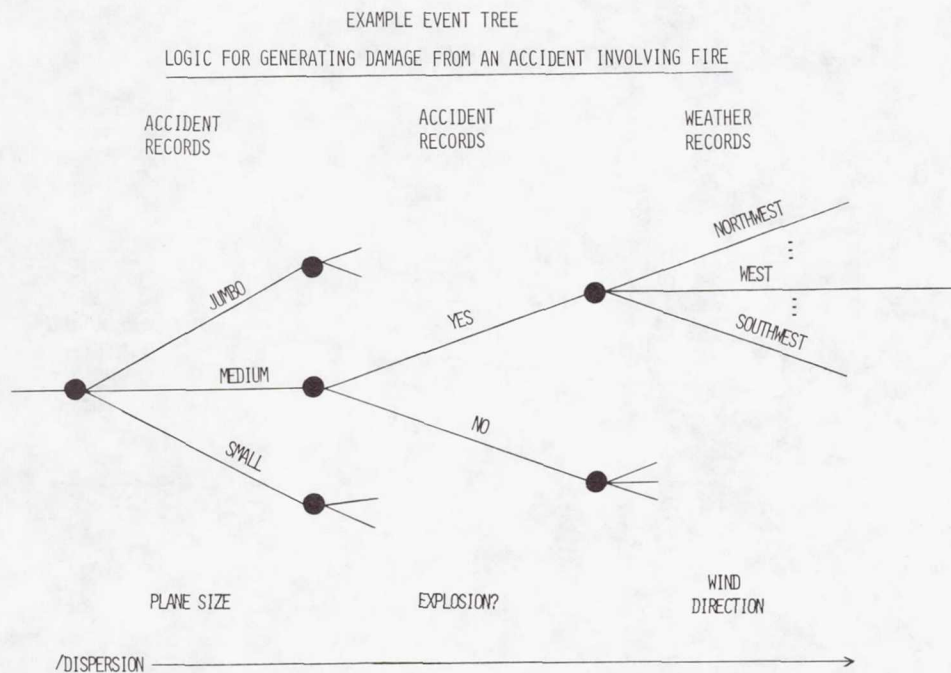

Figure 9

is also determined by random selection. The presence of an explosion determines not only how much material is released, but how far it disperses. If there is an explosion, most of the material is likely to be contained within a 10-mile area. If there is not an explosion, much of the material can be dispersed as far away as 100 kilometers or more. One of the two explosion paths is chosen using the random process. The wind direction is determined by random selection from weather records for the location chosen in the first step. At this point, the use of the random selection processes is completed. The dispersion of released carbon fibers can now be calculated based on an accident scenario constructed from probabilities derived from accident records, operational experience, and projections of the amount of carbon fiber to be used on aircraft in the future. The dispersion footprints, or isopleths of constant exposure, are related to specific geographical locations.

As illustrated in figure 10, by using a census map, with the various exposure isopleths superimposed, the areas of the city and countryside affected can be identified. The example in figure 10 shows only three such areas: commercial, public (which could be post offices, hospitals, and fire stations), and residential. Given the areas affected, the next step is to determine transfer functions into the building types within each of these areas and the vulnerability of the various equipment types within each building type. Equipment examples are: computers in the commercial

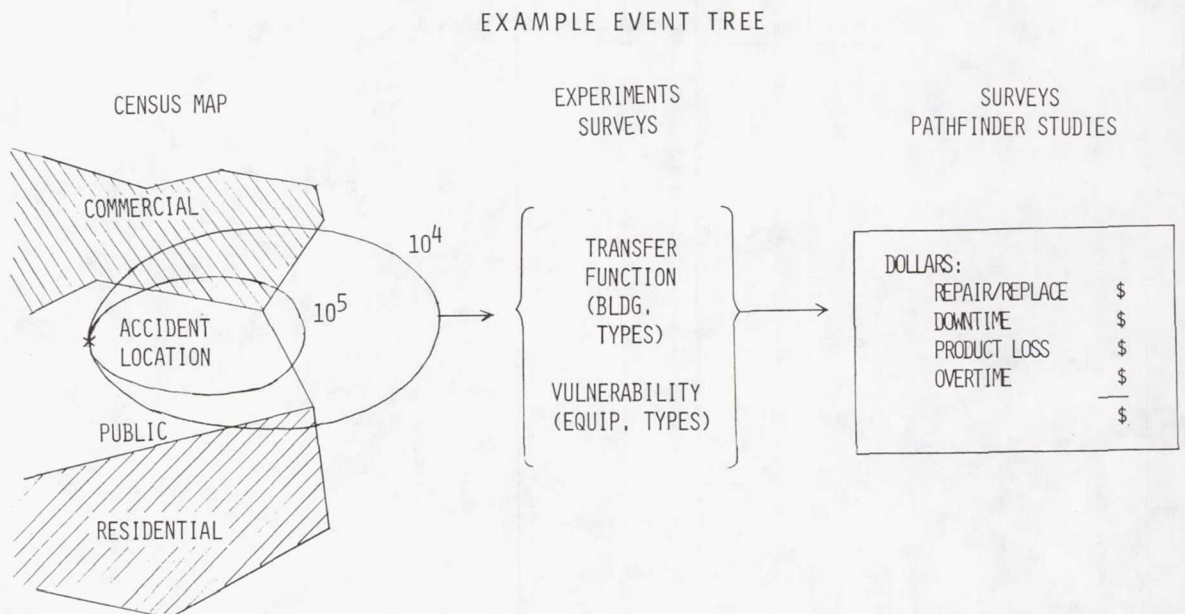

Figure 10

districts, stereos and televisions in the residential areas, and telephone exchanges in the public area. Finally, the dollar loss is determined using impact surveys and pathfinder studies. Four examples of impact costs are repair or replacement of equipment, overtime, downtime, and product losses. The sum of these costs gives the cost impact from one accident. By using the historical five or six accidents a year involving fire, the random selection of nodes in the event tree and the cost calculation is repeated five or six times and the cost summed to obtain one estimate of the national risk. However, one estimate is not enough to obtain a statistical distribution of estimates and, therefore, the calculations of the national risk must be repeated a large number of times.

Suppose we repeat these calculations 1,000 times and that they give the results shown in figure 11. The first two columns of figure 11 give dollar values for a year's national costs, or damages, and the number of the 1,000 trials that had those dollar values. For example, the first line of the first two columns gives that 50 of these 1,000 trials had zero costs. Perhaps very little fiber was released or perhaps all that was released went over the water or into the countryside. The last line gives one case that had a very high cost. Perhaps this case resulted from use of a jumbo plane and carbon-fiber release over highly industrialized areas.

EXAMPLE
DENSITY AND CUMULATIVE TABLE

NATIONAL COSTS

TRIALS THAT HAVE \$ VALUE OF \$X	YEARLY NATIONAL COSTS, \$(X)	X	DENSITY PROBABILITY	=	PRODUCT	TRIALS THAT HAVE \$ VALUE OF ≥ \$X	CUMULATIVE PROBABILITY
50	0		.05		0	1000	1.00
200	\$ 1,000		.20		\$ 200	950	.95
100	10,000		.10		1,000	750	.75
400	100,000		.40		40,000	650	.65
246	200,000		.246		49,200	250	.25
3	1,000,000		.003		3,000	4	.004
1	10,000,000		.001		10,000	1	.001
1000					$\Sigma = 103,400$		

EXPECTED NATIONAL VALUE \$103,400

Figure 11

From the first two columns of numbers, we calculate a density function, with values given in the third column, by simply taking the number of trials that have a certain yearly national cost and dividing that number by 1,000. Note that, to simplify the example, all numbers in figure 11 are rounded off and grouped into only seven categories; in reality, of course, there are hundreds, perhaps thousands, of categories. The fourth column gives the product of the second and third columns. This column weighs the dollar costs by the frequency with which they occur. Summing up these dollar costs gives the expected value, which is the most common summary statistic used in risk analyses. The expected national value of \$103,400 in this example is very small, especially with respect to the extreme of \$10 million. In this example, there is a very high frequency of middle and small costs that tend to drown out the very large costs.

Some of the other types of summary risk measurements are the median cost, which is \$100,000, and the extremes, which are \$0 and \$10 million. A particular interest is the frequency with which the upper extreme occurs. One way of looking at this .001 frequency is to say that roughly every one in a thousand years a \$10 million national cost can be expected. The last column gives the cumulative probability, which is the basis of the most frequently used type of curve in risk analyses. This column is obtained by simply cumulating the probability given in the third column. For example, the bottom values of 0.001 are the same. The next-to-bottom cumulative probability is obtained by adding the two bottom density probabilities of 0.001 and 0.003.

In figure 12, these cumulative probabilities have been plotted to give a risk profile. The ordinate gives the values from the last column of figure 11. The abscissa gives property damage in dollars. Note that the curve is plotted on a log scale. The error bounds in this illustrative problem are equally weighed except when they're bounded by one.

Figure 13 gives several summary points about the capability of risk analysis methodology. First, risk methodology integrates the data and engineering judgment into a logical framework. Second, it combines both deterministic and probabilistic models. Third, it permits sensitivity analyses of key assessments. Two examples are the carbon fiber usage projections and the nature of released fiber; in particular, the fall rate. For example, what are the effects from single fibers versus those from lint or clumps. Finally, risk methodology permits evaluation for alternative sources, where alternative sources might be exemplified by general aviation or helicopters in civil aircraft or by other types of sources such as automobiles.

EXAMPLE

ONE-YEAR RISK PROFILE

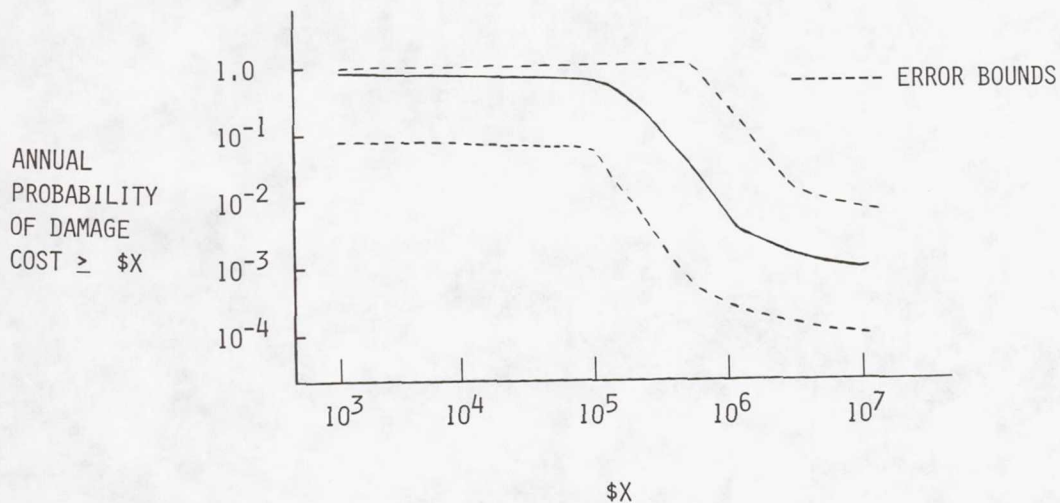

Figure 12

SUMMARY

CAPABILITY OF RISK ANALYSIS METHODOLOGY

- INTEGRATES DATA AND ENGINEERING JUDGEMENTS IN A LOGICAL FRAMEWORK
- COMBINES BOTH DETERMINISTIC AND PROBABILISTIC MODELS
- PERMITS SENSITIVITY ANALYSIS OF KEY ASSESSMENTS
 - CARBON FIBER USE PROJECTIONS
 - NATURE OF RELEASED FIBER
- PERMITS EVALUATION FOR ALTERNATE SOURCES

Figure 13

Page intentionally left blank

Leon Pocinki
ORI, Inc.

I will present a status report on the ORI assessment of the risk at Washington National Airport and the surrounding Washington, D.C., metropolitan area associated with commercial operations of aircraft with graphite fiber composite in their structures. Figure 1 is an outline of my presentation.

OUTLINE

- **OVERALL STRATEGY**

- **NEED FOR INDIVIDUAL AIRPORT RESULTS**

- **AIRPORT-METRO AREA MODEL**
 - SUB MODELS**
 - METHOD**
 - ASSUMPTIONS**
 - DATA**

- **PRELIMINARY RESULTS FOR NATIONAL AIRPORT —
D.C. AREA**

Figure 1

First, I'd like to spend a minute discussing the overall strategy and the resulting need for individual airport analyses of the type we're going to describe. I shall then describe the actual model for assessing the risk to an airport and to the surrounding metropolitan area. Then, for that risk assessment model, I'd like to describe the set of submodels that comprise the overall model. Each one of the submodels will be described in terms of its three principal elements: the method that is used, the assumptions that are required in order to use that method, and the required data. Types, sources, and some examples of the data that are required as input to each model will be

presented. Finally, we'll present preliminary results based on those data, using the methods we will have described, for the Washington, D.C. - Washington National Airport risk analysis.

The overall strategy for developing the national risk profile, that Dr. Credeur showed us in a hypothetical example earlier, is shown schematically in figure 2. The cycle in the middle tells us that we're still discussing among ourselves, and with the Project Officer and her associates, the appropriate methods to use for blending the risk profiles developed for individual airports. On the other hand, all the methods that we've discussed to date involve combining results for individual airports in order to develop the national risk profile. For this reason, we felt it was necessary to analyze at least one airport and develop methods that could be applied to any airport, given appropriate data for that locale. With that in mind, I would like to describe the model for the individual airport and, as I said earlier, we will blow that up in detail and describe all the subelements that comprise that model in terms of the methods used, assumptions made, and the necessary input data.

NATIONAL RISK PROFILE DEVELOPMENT STRATEGY

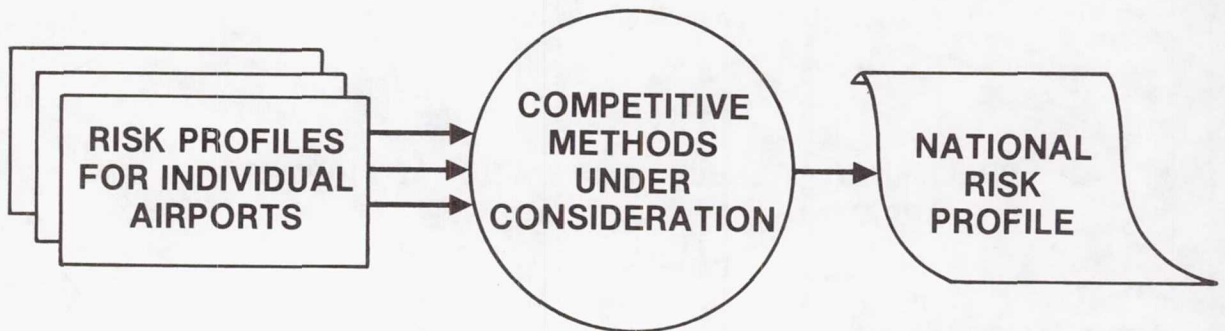

Figure 2

The airport model involves the major steps shown on figure 3. We first have to decide what time frame we're interested in and how long a time period we want to simulate. For that period, we estimate the number of accidents at this airport. Then for each

AIRPORT-METRO AREA GRAPHITE FIBER RISK ASSESSMENT MODEL

- SELECT TIME PERIOD
- ESTIMATE NO. OF ACCIDENTS AT THIS AIRPORT DURING PERIOD
PROCESS ACCIDENT
REPEAT FOR ALL ACCIDENTS IN PERIOD
- COMPUTE STATISTICS OVER ALL SAMPLES

Figure 3

accident simulated, we do something called "Process Accident", which involves computing the likelihood of damage to different facilities and estimating the resulting costs. We repeat that step for all the accidents in the time period we're modeling. We then generate more accidents for another time period and compute the statistics over all periods (or samples) to get the type of statistical distribution that Dr. Credeur showed us earlier. The statistical distribution is obtained, therefore, by the use of what is generally called a "Monte Carlo Simulation." What I'd like to do now is expand on the risk assessment model and discuss it in terms of its components.

We will concentrate on the calculations we're doing for 1985 as our time period or time frame. Let's discuss the first step beyond that one in the risk assessment model for a particular airport or area. It is necessary to start with an estimate of the expected number of accidents at an airport during the simulated time period. As indicated on figure 4, the method is to allocate a fraction of the national total accidents to the combination of aircraft category and airport. The fraction is the ratio of operations for that aircraft type - aircraft combination to operations for the total U.S. Incidentally, the format we're following in figures 4 and 5 is the one I'd like to use throughout: method, assumption, and the data that is used

ESTIMATE NUMBER OF ACCIDENTS IN SAMPLE TIME PERIOD

METHOD:

- ESTIMATE NUMBER OF ACCIDENTS FOR YEAR OF INTEREST
- FOR EACH A/C CATEGORY-AIRPORT, COMPUTE RATIO OF OPERATIONS TO TOTAL U.S. OPERATIONS

ASSUMPTION:

- EXPECTED NUMBER OF ACCIDENTS IS PROPORTIONAL TO NUMBER OF OPERATIONS

Figure 4

DATA:

- NATIONAL TRANSPORTATION SAFETY BOARD:
ESTIMATE 6 FIRE ACCIDENTS IN U.S. FOR 1985
- FAA AIRPORT EMISSIONS DATA BASE/WASHINGTON NATIONAL AIRPORT OPERATIONS IN 1985:
 1. LARGE (DC-10, L1011, 747 . . .) 18,850
 2. MEDIUM (727, 757, 767, 707, DC-8 . . .) 124,766
 3. SMALL (737, DC-9 . . .) 60,284
- FAA AVIATION FORECASTS FY 1978-1989:
TOTAL U.S. OPERATIONS 11,700,000

Figure 5

as input to the calculation. Again the basic assumption in performing this calculation is that the number of accidents at a particular place is proportional to the number of operations. We've tested that relationship and it is quite good. In order to obtain the necessary data we have to go to the primary data source for aircraft accident data, we have to go to the primary data source Board. In this case we're interested in accidents involving fires in the 1985 time period. We've estimated, on the basis of historical data from the National Transportation Safety Board, that a reasonable number of accidents involving fires for commercial operations in 1985 in all the United States might be six.

In order to allocate a fraction of those six accidents to Washington National Airport, we use additional information in a data base that ORI developed and maintains under contract to FAA. These are the estimated number of operations of aircraft in the three size classes shown on figure 5. The actual aircraft designators shown with the three classes are meant to be indicative of aircraft in those size classes today - they are not necessarily the aircraft that will be operating at National Airport in 1985. In order to get the denominator - the total number of certificated air carrier operations, we use the official FAA aviation forecast: in 1985 there will be about 11,700,000 certificated air carrier operations in the United States.

The next major step in applying the risk assessment model to a particular airport is to perform a set of calculations that we call "Process Accident." Once we have an estimate of the number of accidents, we want to deal with them one by one, and in order to process the accident, we have several calculations to go through as indicated on figure 6. These are performed with considerable speed by a computer that we have programmed to do the job. In the present case the computer is an IBM 370/155. Fortunately for me, many of the steps in the complete calculation were discussed by previous speakers in considerable detail. Basically, as Dr. Credeur pointed out, we want to develop a statistical description of the risk, and to do that, we want to draw random samples from distributions of such things as the accident characteristics, including the operational phase during which the accident took place and the accident location.

We then compute the exterior exposure downwind of the accident for a series of representative locations. For each of these locations we've defined combinations of commercial, industrial, and residential units. For each point, we can then compute the interior exposure, the associated failures, and the cost of those failures. The computer then goes back, performs this routine for all the locations impacted by the accident, adds them up, and is then finished with the accident. It then goes back and looks at the next accident in this time period, finishes all

PROCESS ACCIDENT

- **SAMPLE ACCIDENT CHARACTERISTICS, A/C CATEGORY, OP PHASE, LOCATION**
- **COMPUTE DOWNWIND EXTERIOR EXPOSURE FOR REPRESENTATIVE LOCATIONS**
- **FOR EACH LOCATION, COMPUTE INTERIOR EXPOSURE FOR INDUSTRIES, DWELLING UNITS**
- **COMPUTE EXPECTED FAILURES EACH INDUSTRY, DWELLING UNIT**
- **COMPUTE COSTS OF FAILURES**
- **SUM COSTS AT EACH LOCATION**
- **SUM OVER ALL LOCATIONS, THIS ACCIDENT**

Figure 6

accidents in the time period, and then performs the next replication of the time period (or the next sample). In order to explain this in more detail, I'm in effect going to blow up the "Process Accident" routine which is the computer program that's at the heart of the calculation.

As indicated in figure 7, the first thing we have to do is to develop - by sampling from appropriate statistical distributions - information about the simulated accident. In order to develop the characteristics of the accident we're investigating, we sample from historical distributions that describe the location of accidents involving fires and the operational phase during which those accidents occurred. We calculate the fraction of the aircraft destroyed by fire from analyses of individual accidents in the NTSB files. The assumption without which the calculation should not proceed is that the aircraft accident data are statistically homogeneous -- put another way: we have to use aggregate data from all accidents recorded in recent history throughout the United States to prepare these distributions for the individual airport we're studying. Examples of the input data are shown on figure 8. The data comes from the National Transportation Safety Board files: annual accident summary reports, report of individual accidents, and finally, the actual docket for each accident. The numbers on figure 8 are examples of the data we need: the distribution of fire accidents over

ACCIDENT CHARACTERISTICS

METHOD:

- SAMPLE FROM HISTORICAL DISTRIBUTIONS FOR LOCATIONS, OP-PHASE
- FRACTION OF A/C DESTROYED BY FIRE ESTIMATED BY ANALYSIS OF INDIVIDUAL ACCIDENTS

ASSUMPTION:

- ACCIDENT DETAIL DATA ARE HOMOGENEOUS
- U.S. AGGREGATE DATA CAN BE APPLIED TO INDIVIDUAL AIRPORT

Figure 7

DATA:

FROM NATIONAL TRANSPORTATION SAFETY BOARD FILES AND ACCIDENT REPORTS

- DISTRIBUTION OF FIRE ACCIDENTS
 - 0% STATIC
 - 0% TAXI
 - 20% TAKE-OFF
 - 20% IN FLIGHT
 - 60% LANDING
- ESTIMATED FRACTION OF A/C INVOLVED IN FIRE
 - 0% STATIC
 - 0% TAXI
 - 20% TAKE-OFF
 - 30% IN FLIGHT
 - 50% LANDING

Figure 8

operational phase and then the estimated fraction of the aircraft involved in the fire for fire accidents occurring in the different operational phases for which data are tabulated. Our estimate - on the basis of an analysis of about five years' accidents in considerable detail - is that about 20 percent of the aircraft would be involved in a fire that results from a take-off accident; 30 percent for an in-flight accident; and 50 percent for a landing accident. A study by the Stanford Research Institute recently made available to us, covering a larger sample, is essentially in agreement. I want to point out that, although the numbers in the lower right of figure 8 add to one hundred percent, they do not have to.

The other thing we have to know about the accident is the amount of fiber liberated which is given on figure 9. Again, the aircraft types are those defined jointly by ORI, NASA, and the airframe manufacturers. The amount of graphite in the structure is based on estimates that we've mutually agreed on. We've shown on the right the amount of fiber in pounds that we estimate would be liberated in an accident for each aircraft category, for an accident in each operational phase. There are two other phases in which, on the basis of our analysis, we would not expect any fiber to be liberated because fire would not result from the accident, so we haven't shown those. The basic assumption here is that only 20 percent of the graphite involved in the accident is released in the form of the single fibers that

FIBER LIBERATED PER ACCIDENT WITH FIRE — 1985 (Pounds)

A/C CATEGORY	GRAPHITE IN STRUCTURE	OP-PHASE		
		TAKE-OFF	LANDING	IN-FLIGHT
1. LARGE DC-10, L1011, 747	1000	40	100	60
2. MEDIUM 727, 757, 767, 707, DC-8	300	12	30	18
3. SMALL 737, DC-9	200	8	20	12

NOTE: ASSUMES 20% OF INVOLVED FIBER IS RELEASED

Figure 9

the analysis is concerned with - as opposed to clumps. This is based on limited experimental data.

The next step in the "Process Accident" program is to compute the downwind exposures at representative locations, and in order to do that, the computer has to know where those locations are. So, we've developed methods for defining points that we want to look at in the geographical area. We define representative points for industrial, commercial, and residential centers for each city and county in the geographical area of interest. As indicated in figure 10, the basic assumption that we've made is that the industrial and residential units of the types we're interested in are distributed relatively uniformly over the sub-area that's represented by a particular point. The kinds of data we need include population, for which we use the 1970 census. For business types, sizes, and locations, we take advantage of a scheme developed primarily by the Department of Commerce and used by many agencies: namely, the SIC (Standard Industrial Classification) code. We've limited ourselves to what is called the two-digit breakdown, some examples of which are shown at the bottom of figure 11. For example, SIC code 23 covers places that manufacture apparel and do other textile processing. Number 27 is in the manufacturing category for printing and publishing. 54 is the code number in the retail business group comprising food stores. SIC 60 is banking. Number 62 is stock brokers and so on. The

DEFINE REPRESENTATIVE LOCATIONS

METHOD:

- **DEFINE INDUSTRY AND RESIDENCE CENTERS FOR EACH CITY, COUNTY**

ASSUMPTION:

- **INDUSTRIAL UNITS AND RESIDENCES UNIFORMLY DISTRIBUTED OVER SUB AREAS**

Figure 10

DATA:

- **POPULATION — 1970 CENSUS**
- **BUSINESS TYPES, NUMBERS, PAYROLL BY 2-DIGIT SIC*
CODE — COUNTY BUSINESS PATTERNS**
- **BUSINESS LOCATIONS — LOCAL & STATE DEVELOPMENT
AGENCIES**

*SIC = STANDARD INDUSTRIAL CLASSIFICATION

eg: 23, MANUFACTURING APPAREL
27, PRINTING & PUBLISHING
54, FOOD STORES
60, BANKING

Figure 11

County Business Patterns identifies the kinds of business performed in an individual county using this terminology. It tells us how many employees there are; there's a frequency distribution of establishments by size, as well as payroll data.

In order to determine where clusters of these businesses are on a scale finer than the county, we deal with people at state and local economic development agencies. An example of the kind of thing we've done is illustrated on figure 12. The scale on figure 12 indicates that Howard County, at its closest point, is 15 or 20 miles from National Airport. The inset map in the lower left of figure 12 shows Howard County in more detail. In order for us to represent Howard County for the calculation of graphite fiber impact, we've located a point at Ellicott City which is residential; we have located another point at Columbia, Maryland - a so-called new town - as a center of residences and commercial interests, primarily retail establishments. The area marked by four heavy dashed lines is the part of Howard County zoned for industry. The heavy dot is where we have placed all the significant industry in Howard County and essentially assumed that the part of Howard County to the left (west) of those three points is essentially farm land and not of great interest to us from the risk-assessment point of view. The same methodology has been applied to Washington, D.C., and the

DATA:

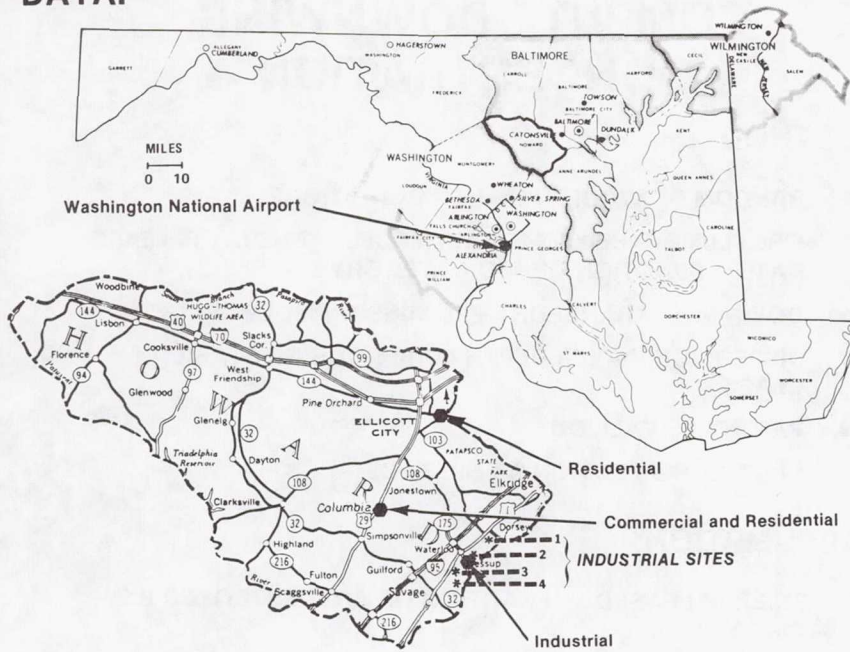

SOURCE: STATE OF MARYLAND DEPARTMENT OF ECONOMIC AND COMMUNITY DEVELOPMENT

Figure 12

Maryland and Virginia countryside within about 50 miles of Washington National Airport to define the set of representative locations for which the computer program called "Process Accident" will calculate exterior exposures.

Once we've generated an accident with its characteristics - "drawn an accident" is the customary expression - we proceed as indicated in figure 13 to compute the downwind concentrations and the associated exposure at the set of points we're interested in. In order to do that, we use a technique similar to the turn of the roulette wheel that Dr. Credeur talked about to draw a set of weather variables from a distribution that gives the observed frequency with which different combinations of wind speed, direction, and stability categories occurred in the past. These data are made available by the National Climatic Center for major weather stations around the country--so we use the data set for Washington National Airport. This process gives us the weather conditions for the accident we are now processing. We calculate the pertinent plume rise characteristics using the so-called Briggs model that was described for us by Dr. Wolf Elber yesterday. The energy release rate is a function of the aircraft category. The assumption is that the size of the burning fuel pool, and thus the heat release rate, is proportional to the square of the wing span of the aircraft. The computer program uses inputs to the Briggs calculation based on the size of

COMPUTE DOWNWIND CONCENTRATION

METHOD:

- RANDOM DRAW OF WEATHER CONDITIONS
- FIRE PLUME BASED ON BRIGGS MODEL — ENERGY RELEASE RATE A FUNCTION OF A/C CATEGORY
- DOWNWIND TRANSPORT — GAUSSIAN MODEL
- DISPERSION, LAYER DEPTH FUNCTIONS OF STABILITY CLASS
- PARTICLES FALL OUT
- PARTIAL REFLECTION AT SURFACE

ASSUMPTION:

- FIBER RELEASED = FRACTION OF A/C DESTROYED BY FIRE X 0.2
- FIBERS MOVE WITH MEAN WIND
- DISPERSION IN VERTICAL AND LATERAL DIRECTIONS

Figure 13

typical aircraft in each category involved in the simulated accident.

The subsequent downwind transport calculation is based on a Gaussian model. The dispersion parameters that go into that calculation are based on a set of inputs from EPA. As shown on figure 14, they are from the CRSTER model that EPA makes available. The inversion height - or layer depth - is from a publication by George Holzworth. He has essentially developed a climatology of mixing depths or inversion heights and associated wind speeds for different stability classes. The model we use then takes account of dispersion, allows the particles to fall to the surface, and allows for partial reflection of the fibers at the surface and for reflection at the inversion. The basic assumption we've made is that the fraction of aircraft destroyed in the fire is used as an estimate of the fraction of the amount of fibers in the aircraft released. To be more precise, the amount of fiber released is set equal to the fraction of aircraft consumed by fire, which we have estimated from accident data, times the factor 0.2 to represent that part of the graphite that will end up as single fibers. The fibers move downwind with the mean wind, spreading by dispersion only in the vertical and lateral directions. These latter are standard assumptions in most of the Gaussian plume models used in pollution studies.

DATA:

- **WIND SPEED, DIRECTION, STABILITY CLASS FROM NATIONAL CLIMATIC CENTER**
- **DISPERSION — “CRSTER” MODEL FROM EPA/MODIFIED**
- **LAYER DEPTH — HOLZWORTH, *MIXING HEIGHTS, WIND SPEED . . . EPA, 1972***

Figure 14

The particle fall rate is represented by using a "tilted" plume model, which is a variation of the basic Gaussian model.

Having computed the exterior concentration and the resulting exposure at our representative locations, the next step, as indicated in figure 15, is to compute interior exposures for the places we're interested in. To do that, we assumed that - for each one of the two-digit SIC codes - we can define a representative building. For each representative building type we defined ventilation parameters. As indicated on figure 16, the data source for most of this work is a volume put out by the Carrier Corporation for the design of air conditioning systems. That was the basic source of information for air leakage into buildings. The calculation proceeds along the lines that Mr. Israel Taback described.

For the particular building parameters we've assigned to each business and industrial category, we compute an interior exposure which is a function of the external exposure, the ventilation parameters, as well as the wind speed, and the fall rate of the particles. The basic assumption here is that these typical facilities can be defined and that all facilities associated with a given type of business or industry are similar. I should mention that, in addition to the Carrier Corporation's

COMPUTE INTERIOR EXPOSURE

METHOD:

- FOR EACH INDUSTRY CLASS, DEFINE VENTILATION PARAMETERS FOR TYPICAL FACILITY
- COMPUTE INTERIOR EXPOSURE FROM EXTERIOR EXPOSURE, BUILDING PARAMETERS, WIND SPEED, PARTICLE FALL RATE

ASSUMPTION:

- TYPICAL ENCLOSURES CAN BE DEFINED

Figure 15

DATA:

- CARRIER CORPORATION
*HANDBOOK OF AIRCONDITIONING
SYSTEM DESIGN 1965*
- SITE VISITS

Figure 16

handbook, we made quite a few site visits in the Washington metropolitan area. They were listed on one of the slides that Mr. Ansel Butterfield used yesterday in his talk on "Pathfinder Surveys."

At this point, we have simulated an accident, computed the downwind exterior exposure, and moved the fibers inside typical facilities at representative locations. We now need to estimate the expected failures. As indicated on figure 17, the basic method is to define typical systems for each of the two-digit

COMPUTE FAILURES

METHOD:

- **DEFINE TYPICAL SYSTEMS FOR EACH INDUSTRIAL CLASS, RESIDENCE**
- **COMPUTE OVERALL FAILURE PROBABILITY FOR EACH TYPICAL FACILITY USING INDIVIDUAL COMPONENT FAILURE PROBABILITY, COMPUTED EXPOSURE**

ASSUMPTION:

- **TYPICAL SYSTEMS CAN BE DEFINED**
- **EXPONENTIAL FAILURE MODEL FOR INDIVIDUAL EQUIPMENTS**

Figure 17

industrial-commercial SIC categories that are present in Washington, D.C. and environs. For each of these systems, we computed an overall failure probability. Figure 18 illustrates the kind of data we used. As a result of digging into the journals and reports listed, we were able to develop a model of the type shown for all the industries and businesses we were concerned with. It says that, typically, power comes in from the outside through a transformer, passes through a switch panel and/or terminals on the transformer, and flows to something we call common equipment, computers or control systems for the entire facility. Power is then split into a set of parallel lines, each of which might involve a servo and a control system.

DATA:

FACILITY MODELS FROM

- IEEE SPECTRUM
- INSTRUMENT & CONTROL SYSTEMS
- AUTOMATION/INDUSTRIAL ENGINEERING
- MACHINE DESIGN
- STANDARD HANDBOOK OF MECH. ENG.
- CONTROL ENGINEERS HANDBOOK
- SITE VISITS

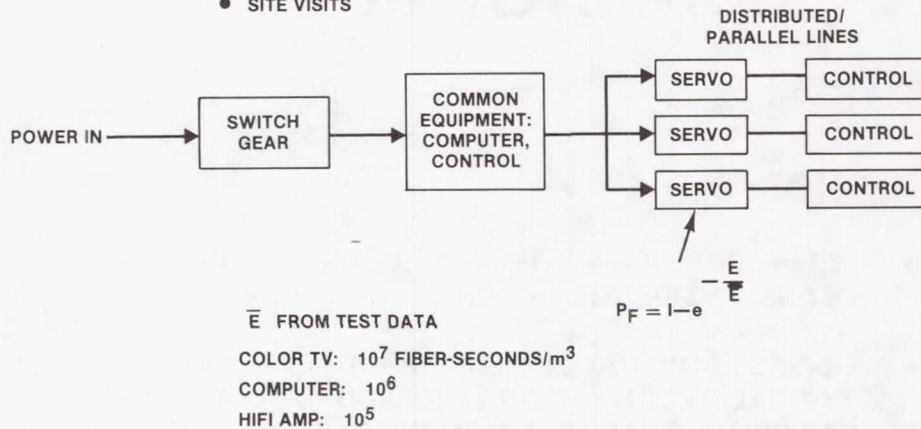

Figure 18

The probability of failure for each individual element in the system obeys an exponential law. As shown on figure 18 the probability of failure is $1 - \exp(-E/\bar{E})$, where \bar{E} is a number we get from test data of the type described by Mr. Taback in his lecture on vulnerability. From the available experimental data we matched the tested equipment to actual industrial and commercial equipment as closely as possible to obtain the appropriate \bar{E} . With the computed interior exposures E , and \bar{E} , we compute the failure probabilities for individual equipment. With these individual probabilities properly hooked together, we obtain - for the computed interior exposure - an estimate of the probability that a plant or facility of a particular industrial-commercial category will fail. A basic assumption is that such typical systems can indeed be defined and that the exponential failure model is appropriate for the individual equipment. Once we've computed these expected failures, we have to estimate the cost impact. That is the next step in our "Process Accident" calculation.

To compute the costs of failures, the basic method, as indicated on figure 19, considers that the fraction of the industry down or the fraction of production lost is equal to the probability that an industrial unit of that class has failed. The residential unit cost is estimated by looking at the costs of repairing equipment in the household that has failed. The data

COST OUT FAILURES

METHOD:

- FRACTION OF INDUSTRY DOWN = PROBABILITY OF INDUSTRIAL UNIT FAILING
- COST OF OUTAGE IS FRACTION OF LOCAL GDP, BY SIC
- RESIDENTIAL UNIT COST IS COST OF REPAIRING FAILED EQUIPMENTS

ASSUMPTION:

- INDUSTRIAL IMPACT MEASURABLE BY GDP
- NATIONAL PRODUCTIVITY VALUES CAN BE APPLIED LOCALLY

Figure 19

and the actual formula or algorithm for industrial cost estimating are shown on figure 20. It says that for a particular SIC classification, we can estimate local productivity by looking at the Gross Domestic Product (a term that is closely related to what everyone calls the GNP (Gross National Product, the sum of all goods and services produced in a year)).

The Gross Domestic Product is the Gross National Product with all production in the United States by foreign manufacturers added and all production by American manufacturers overseas taken away. The basic approach is to say that the productivity per payroll dollar can be estimated by looking at the amount of Gross Domestic Product assigned to each economic sector on the national level. We take the Gross Domestic Product associated with each type of industry and divide it by the national payroll for the same type of industry - that, in effect, gives us the impact of a payroll dollar on Gross Domestic Product. We then multiply that result by the local payroll for the same industrial category obtained from a document called County Business Patterns for each county (as opposed to the County Business Patterns, National Summary.) We then multiply that result by the probability of failure for that class of industry that we just computed at the particular location. We have assumed that the impact lasts one day - so we have divided the annual GDP by 365 in estimating failure impacts. We add these costs up over all SIC categories - all

DATA:

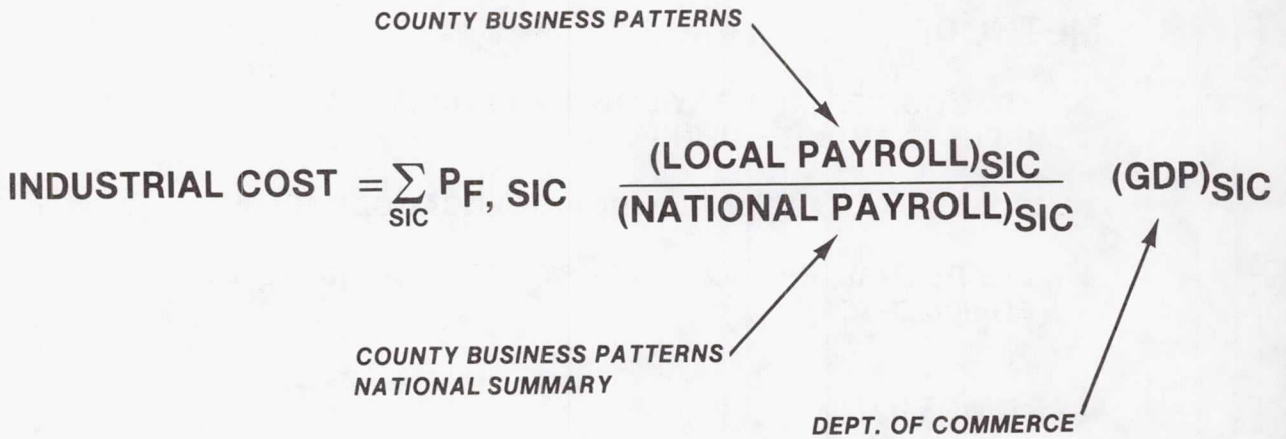

Figure 20

industries or kinds of commerce represented at this location. That is the way we estimate the industrial and commercial impact of a failure at the local level.

The basic assumption is that industrial impact can be measured this way and that the national productivity estimate obtained by dividing Gross Domestic Product by the national payroll for a particular industrial sector can be applied locally. In other words, it says that the workers, say in printing or publishing at Time-Life Books in Alexandria, are as efficient as the "national average workers" in the same industry.

The next calculation, as indicated on figure 21, is to estimate the impact on individual households. Again, as described by Mr. Taback yesterday, we have estimated some fraction of households as being air-conditioned, some not air-conditioned, where the fraction that is air-conditioned decreases with distance away from the metropolitan area - assuming that farmers in Talbott County do not have air-conditioned farmhouses. We assume, on the other hand, that everybody in Montgomery County is air-conditioned. We've estimated the number of TV's and Hi-Fi's per household, again assuming that although the national average is one TV per household, the number will be a little higher in more affluent communities and lower in less affluent communities. With those

HOUSEHOLD COST MODEL

METHOD:

- VENTILATION PARAMETERS DEFINED FOR A-C, NON A-C HOUSEHOLDS
- ESTIMATE NUMBERS OF TVs, HIFIs PER HOUSEHOLD FOR EACH GEOGRAPHICAL AREA
- COMPUTE NUMBER OF TV, HIFI FAILURES EACH AREA
- COMPUTE TOTAL REPAIR COSTS

ASSUMPTION:

- HOUSEHOLDS UNIFORMLY DISTRIBUTED OVER GEOGRAPHICAL AREAS

Figure 21

numbers we were able to compute the estimated number of TV and Hi-Fi failures for each one of our residential units. We estimated the total repair costs based on a gross cut: it costs 50 dollars to fix a TV set and \$75 for a Hi-Fi, if it failed as a result of the graphite fiber problem. Again, the basic assumption is that the households are uniformly distributed in the neighborhood of the representative points we've selected.

We find that we have now more or less worked our way painstakingly through the calculation. The next step is one that doesn't need any technical explanation - we add up the costs for everything at each location and then add up the costs for all locations for this accident.

That takes us through the "Process Accident" routine, and if we look back at the Airport-Metropolitan Area model we find that once we have finished the "Process Accident" routine we repeat it for every accident in the simulated time period. We then repeat the time period over and over again to develop statistics over many sample time periods. I feel that I have now described the strategy - why we need the individual airport results - and I have described the Airport-Metropolitan Area model in some detail. I would like to stick to our original outline and show you several preliminary results for the Washington National Airport - Washington Metropolitan Area risk assessment. The map we looked

at (figure 12) showed that the area we needed to consider included the Baltimore SMSA (Standard Metropolitan Statistical Area), the Washington, D.C., SMSA, and the Wilmington, Delaware, SMSA. So, when we say Washington, D.C., we're really talking about Washington, D.C., Baltimore, and Frederick, Maryland, as well as large parts of Virginia.

We are still working on the processing of the statistics to develop risk profiles. Figure 22 shows some sample results garnered from the simulation of 2,000 accidents processed by the computer in exactly the way I described. Over the 2000 accidents - using the best estimates we could get for our 1985 scenario - preliminary results indicate that expected cost, or average cost per accident, is on the order of 5,000 dollars. If one looks at the accident rate and asks for the numbers per year - the expected cost per year is on the order of a little more than 100 dollars; because, the likelihood of an accident at the Washington National Airport involving fire in an aircraft with graphite fiber is quite small. If you remember, we started off with an estimate of 6 fire accidents per year in the country and that number is then degraded by the share of operations at Washington National Airport, further degraded by the fact that about 20 percent of the 1985 aircraft fleet will be using graphite fiber. We can also look at the distribution of accidents. We've estimated that - at the relatively high end of the spectrum - .005,

1985 RESULTS 2000 SIMULATED ACCIDENTS

- EXPECTED COST PER ACCIDENT \approx \$5000
- EXPECTED COST PER YEAR \approx \$110
- FRACTION OF ACCIDENTS WITH COSTS $>$ \$200,000 = 0.005

CONDITIONS ASSOCIATED WITH THESE ACCIDENTS:

STABLE ATMOSPHERE
LOW WIND SPEED

PLUME STOPS
AT INVERSION

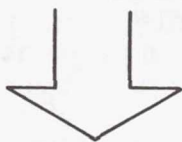

NIGHTTIME OPS

Figure 22

or half a percent, of the 2,000 accidents we simulated ran up costs greater than 200,000 dollars.

Now, I'd like to describe one of the advantages of our method. Although Dr. Credeur concentrated on statistics in her talk and our goal is clearly to develop statistical results, one has the option when using this computer program of asking for what I call almost "infinite detail." We have several options with regard to computer output, starting with the "De-Bug Print" which prints out every calculation the computer made--all the way up to gross statistics summarized over many replications. In between, we can ask for certain results for every accident that was simulated in the program.

What we've done in figure 23 for the 1985 scenario is to show key items that the computer drew from the random distributions described earlier - associated with the results computed for each accident. Of interest is the fact that all of these relatively high cost accidents, in our sample of 2,000, occurred in the most stable meteorological conditions. All but one of the accidents took place in the landing phase. The stability conditions correspond to what Dr. Elber defined as Class E and Class F, the most stable Pasquill-Gifford categories. Associated with them were low wind speeds, but different wind directions. A sample from the statistics for the Washington National Airport shows that all directions are not equally likely, but these

HIGHEST COST ACCIDENTS 1985: BASE CASE

AIRCRAFT CATEGORY	OP PHASE	STAB CLASS	WIND		GRAPHITE RELEASED (POUNDS)	TOTAL COST (\$10 ³)
			SPEED (M/SEC)	DIR.		
MED	LAND	6	2	166°	30	844
LARGE	LAND	5	2	226	100	537
MED	LAND	6	2	174	30	490
MED	LAND	5	2	171	30	387
MED	LAND	6	2	341	30	303
SMALL	TAKE-OFF	6	2	165	80	299
MED	LAND	6	2	177	30	250
MED	LAND	6	2	189	30	250
MED	LAND	5	2	342	30	234
MED	LAND	6	2	162	30	227

Figure 23

are the directions associated with these particular accidents. These stable meteorological conditions, incidentally, might occur with fog or generally reduced visibility. Further, the stable atmosphere and low wind speeds are typical of nighttime conditions. This implies - again, this is a preliminary result based on the analysis of these 2,000 simulated accidents - that if a relatively bad accident of this type were to occur it would appear most likely to occur during nighttime operations. Now, for safety purposes, night ends an hour after sunrise and begins an hour before sunset. So even though a commercial airport typically closes at night, closing time might be ten or eleven PM, which includes a few hours of what Pasquill-Gifford call nighttime. In addition, in these cases the Briggs model is used to estimate the height of the fire plume, and if the plume height provided by the equation is above the inversion, we stop it at the inversion. This is by far the most frequently observed situation. We've shown that, when the amount of fibers increases by a factor of 10, the expected cost per accident increases by a little less than a factor of 10. So that, if the estimated costs for other scenarios are high enough to worry about, these results say that we should probably take a closer look at the meteorology of this situation.

Now beyond these results, we have made some runs for the 1993 time frame using the information shown on figure 24. For

1993 SIMULATION PARAMETERS

	AIRCRAFT CATEGORY	FRACTION WITH GRAPHITE	GRAPHITE PER A/C	AIRPORT OPS	
1985	1	.33	1000	18,850	TOTAL U.S. OPS 11,700,000
	2	.20	300	124,766	
	3	.20	200	60,284	
1993	1	.50	4500	29,621 *	TOTAL U.S. OPS 13,800,000*
	2	.60	1500	143,669 *	
	3	.50	1000	24,710 *	

*1995 FAA PROJECTIONS

Figure 24

1993, the rough situation is that the amount of composite per aircraft with composite structure is expected to increase by about a factor of 5. The number of aircraft with composite in their structures is expected to go up roughly by a factor of 2 to 3. The charts identify the time frame as 1993 although the FAA air traffic projections are for 1995, the closest date for which they are available. With those changes to the basic inputs, the results for 1993 are as shown on figure 25. Assuming that population and industry stay the same, the average cost associated with these accidents on a per-year basis is estimated to be about a thousand dollars and the average cost per accident, on the order of \$20,000. This is based on an analysis of about 2,500 simulated accidents. Using the same \$200,000 dollar cutoff we used for the 1985 scenario, it is estimated that about 2 percent of the accidents involving fires aboard aircraft with graphite fibers in their structures would incur costs greater than \$200,000.

1993 RESULTS

2500 SIMULATED ACCIDENTS

- **EXPECTED COST PER ACCIDENT ≈ \$20,000**
- **EXPECTED COST PER YEAR ≈ \$1000**
- **FRACTION OF ACCIDENTS WITH COSTS > \$200,000 = 0.02**
- **FRACTION OF ACCIDENTS WITH COSTS > \$1,000,000 = .0036**
- **ONE ACCIDENT WITH COST > \$4,000,000**

Figure 25

To wind things up, I would like to summarize our current status, which is shown on figure 26. We have developed a viable airport risk assessment model. In the lingo of computer experts, it is an input-driven model. We have some preliminary results for the Washington National Airport risk for 1985 and 1993. We plan to combine those results appropriately to develop risk profiles for the Washington National Airport and Washington-

CONCLUSIONS

STATUS REPORT

- AIRPORT RISK ASSESSMENT MODEL DEVELOPED
- PRELIMINARY RESULTS PRESENTED FOR WASHINGTON NATIONAL AIRPORT

FUTURE

- RISK PROFILE TO BE CALCULATED
- NATIONAL RISK TO BE ESTIMATED

Figure 26

Baltimore metropolitan area and to go on from that to develop a national risk estimate. That completes the formal presentation.

Question: Do you have the standard deviation for the accident costs as well as the expected value?

Answer: I don't have that right now. We haven't calculated it yet.

Question: When you talk about 6 airplanes a year being involved in fire, you projected that for 1985 . . . Is that 6 airplanes with composite fibers?

Answer: No, six altogether. For fire accidents with composite onboard, it's actually lower than that. It's about 20 percent of that number (6).

Question: All your results are for stable meteorological conditions?

Answer: Well, I'm sorry if you drew that conclusion, because that means I really didn't get my message across very well. The major point of our whole approach has been the sampling of conditions from the appropriate statistical distributions. The meteorology is drawn from a dis-

tribution that gives wind speed, wind direction, and stability class for Washington National Airport. The likelihood that the stability for the particular accident will be an unstable case is based on the historical record of weather as observed at National Airport over a long period of time.

The cases on the last figure were the conditions associated with the ten worst accidents out of 2,000, so it happened that the highest cost accidents according to the model we've developed seem to be those that occurred when stable conditions existed.

We ran 2,000 accidents for 1985. Each time there's an accident the computer asks: "What's the weather for this accident?" It looks at a table, structured by sixteen wind directions, five wind speed ranges, and six stability classes, so there's a box for every one of those combinations. In each box is the fraction of weather observations at Washington National Airport in which that combination was observed. Now the computer makes a random draw, generates a random number, turns the roulette wheel that Dr. Credeur told us about, and picks the weather condition.

Question: (Continues) But we know that accidents tend to occur when the weather is bad.

Answer: Well, that's a problem that we recognized early in the game and addressed with the Project Officer. A decision was made to draw the weather from this random distribution. Now, it's true that one would have expected some bias in accidents toward bad weather, likewise towards cases when there's rain falling. Frankly, for the degree of precision with which we know all the inputs that go into this calculation I feel that that problem is one that we can neglect for the time being.

Dr. Credeur responds: Your point is correct with respect to foul weather. Roughly 40 percent of the accidents that involve fire occur in foul weather; that is, weather involving precipitation. There are two problems with that though. "What is the effect of weather downstream?" You may have rain at an accident site for a very short time or over only a very small portion of the dispersion area. So one of the problems was how to handle the rain factor. The other was that, even if we incorporate it, the greatest impact it would have upon the answer was at most a factor of 2.

The other errors involved in this problem are much greater than that, so for the time being, we're not including it.

Question: Can you report on the results of sensitivity analyses?

Answer: Well, let's put it this way. One of the reasons we developed this approach was to be able to do the kind of things you asked about. We haven't done them yet. The one thing we can say is that the average cost per accident, at least in the range we're dealing with, is roughly linear with the amount of composite. Increase the amount of composite per aircraft by a factor of 10 and the average cost goes up by a little less than a factor of 10.

Question: What about sensitivity of results to the modeling method itself?

Answer: Well, hopefully, we're going to get some of that by comparing results from people who've used other models for the same kind of calculation. One of the big things that our industrial impact calculation leaves out is the cost of repair of equipment that may fail. In making the decision to use this approach - which I must admit is very attractive on the basis of data availability - we argued that the cost of a plant being closed down might roughly be equal to the cost of cleaning up any equipment. At most we thought we might be off by a factor of 2. We've made the assumption here that if a plant is down, it's down for a day. There's a one over 365 factor applied to the GNP numbers. That's our intuitive feel for that part of the problem.

Question: Have you neglected costs due to lawsuits following accidents?

Answer: The honest answer to that is: yes, we are neglecting that part of the problem.

AN ASSESSMENT OF NATIONAL RISK

Arthur D. Little, Inc.

General Concepts and Overall Approach

Ashok Kalelkar

Our presentation reports on the analysis of risk presented by carbon fiber utilization in commercial aviation. At the outset, I would like you to note two things. First, although several speakers yesterday alluded to the entire civil aviation activity, today we are reporting only on one portion of the civil aviation activity, namely, commercial aviation. Second, this is a status report and some of the things that we will be presenting today may change somewhat as our study progresses. As shown in Figure 1, we have a three part presentation: Part I - General Concepts and Part 2 - Overall Approach, which I'm going to discuss; and Part three (which requires a majority of the time allocated to us) Risk Evaluation and Perspective, which will be presented by Dr. Fiksel. The last part of our presentation, which Dr. Fiksel will give, will show national risk profiles for carbon fiber usage in commercial aviation.

THREE PART PRESENTATION

1. GENERAL CONCEPTS
2. OVERALL APPROACH TO CARBON
FIBER COMPOSITE RISK ANALYSIS
3. RISK EVALUATION AND PERSPECTIVE

Figure 1

General Concepts

Risk profiles are a very good way of expressing risks, especially where complicated mathematical models are involved. They express a risk in a relatively easy way and allow decision makers, who may not be interested in the detailed modeling, to make decisions based on what they see graphically. However, risk profiles can also be misinterpreted just as easily. I want to be absolutely certain that our results are not misinterpreted and in order to make sure of that, I'm going to take ten minutes to discuss certain general concepts.

Some of you may already be quite familiar with risk analysis and the concepts inherent in such analysis and for you this discussion may be repetitious. However, I think it is worthwhile because you will understand and appreciate our output better if you understand our terminology and objectives.

Now to begin with, I'd like in Figure 2 to very quickly define risk as we have used it in our analysis. Risk is the potential for realization of unwanted negative consequences of an event or an activity. Today, the event or activity of concern to us is the use of carbon fiber composites in commercial aircraft. The negative consequences, of course, were discussed yesterday. The fact that fibers can be released and can cause negative impacts

GENERAL CONCEPTS

DEFINITION OF RISK

**RISK IS THE POTENTIAL FOR REALIZATION
OF UNWANTED, NEGATIVE CONSEQUENCES
OF AN EVENT OR ACTIVITY**

Figure 2

on electronic equipment is well known. The question must be asked "What is the potential for realization or the likelihood of occurrence of those negative consequences?" As you can see, risk, as we have defined it, has two very definite components. There are probabilistic components, which deal with the likelihood of occurrence of various events, and deterministic components that deal with the actual level of impact that may be experienced. It is very important to keep in mind that "risk", as we use the term throughout our presentation, has these two components. It is meaningless to talk of risk only in terms of probability of occurrence or only in terms of the amount of damage that can occur. The two go hand in hand and are inseparable.

Now, as I'm sure you've gathered from the many presentations that were given yesterday, the use of carbon fiber composites in commercial aircraft does involve some risks. Where there are some risks there is need for an appropriate way of handling those risks through risk management as shown in Figure 3. In this particular case, the Federal Government is essentially placed in the role of being risk manager. A rational way of conducting risk management activities is by going through the three-step process shown: of, first, identifying the risk (again keep in mind the two components of risk); then measuring it quantitatively (it is very important to do it quantitatively); and finally by looking at the measured value to determine if control strategies are required or not, by

DEALING WITH RISK THROUGH RISK MANAGEMENT

RISK IDENTIFICATION

RISK MEASUREMENT

RISK CONTROL

Figure 3

comparing the measured risk against other risks and comparing the benefits to be derived by the use of the CF material against the risks that have been measured.

I don't think it necessary to spend much time discussing risk identification, the first step in the three-step process. Several speakers addressed different areas that deal with the risk associated with the use of carbon fiber composites in aircraft. There's been some past experience. There was an accident of sorts involving an incinerator. There's been substantial experimentation and dissemination testing, with actual burning of composite structures to see how much fiber can be liberated under different fire conditions, and studies of the effects of burns and explosions, of burns alone, and so on. The risk of the problem that we are looking at today has been pretty well identified in terms of the areas identified in Figure 4. There aren't too many unknowns in terms of conceptual identification of what can happen, what different consequences can result and the probabilistic pathways leading to what those consequences might be. In some cases where a certain piece of equipment may not have been properly tested, it is useful to use industrial experience-based judgement, engineering judgement, guesses if you will, to try to assess how things are going to fail, so their failure can be incorporated within the risk analysis. The risk identification step in this risk management scheme has, I believe, been quite well completed.

RISK IDENTIFICATION

- PAST EXPERIENCE – DIRECT OR RELATED
- EXPERIMENTATION
- INDUSTRIAL EXPERIENCE - BASED JUDGEMENT

Figure 4

The next step then is to measure the risk quantitatively as described in Figure 5. This requires that we assess the frequency

RISK MEASUREMENT

- FREQUENCY OF OCCURRENCE OF FAILURE EVENT
- CONDITIONAL OCCURRENCE OF SUBSEQUENT EVENTS
- CONSEQUENCES OF THE EVENT IN TERMS OF TOTAL IMPACT

Figure 5

of the occurrence of the failure event of concern. In our case this is an accident involving an aircraft that has carbon fiber composite structures on it and that is involved in either a fire or a fire followed by an explosion. This frequency can be assessed by looking at historical data on accidents and operations. Once that particular step has been completed, there are several conditional occurrences of subsequent events which must be examined. Given that the fiber is involved in a fire in the aftermath of an aircraft accident, what are the chances that it will be released? What are the chances that there will be wind blowing from a certain direction to carry the fiber a certain way? What are the chances that there will be certain classes of industrial facilities in its path? And so on. Finally, we need to assess deterministically the consequences of the event in terms of total impact. As Dr. Credeur pointed out in her presentation, impacts can vary across a wide spectrum, depending on your interests. We're not that concerned about fatalities or environmental damage or chronic health problems today; we're more concerned with total dollar loss as a result of one of these occurrences.

In Figure 6 I'm going to show how the measured risk can be displayed. Now this is hypothetical, so please, these numbers

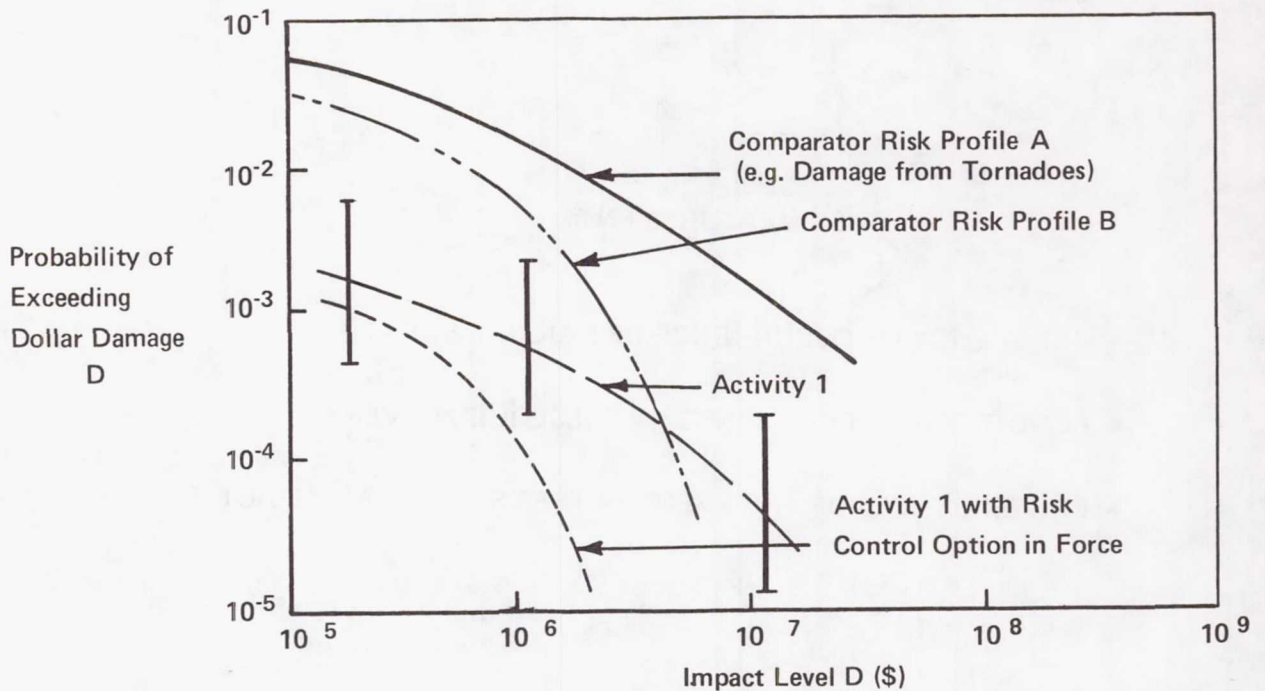

Figure 6

have no bearing on the presentation. I just want to use this for demonstration purposes, because I want to point out five or six things. First, look at Activity One. Suppose Activity One is an activity of concern to us and we evaluate it through our risk analysis scheme and we measure the risk. The measured risk would be portrayed in a fashion as shown depicting the probability of exceeding a certain dollar damage plotted against the dollar damage. For example, if Activity One had the risk profile as shown and you go up to the 10^{-3} probability (which is about one chance in a thousand), you find that the corresponding dollar loss is about a million dollars. If on the same risk profile for Activity 1, you look at an event that has a probability of occurrence of 10^{-4} (one in ten thousand chance), you see that the loss is about ten million dollars and so on.

Curves such as these are very useful when the probability of occurrence can vary over several decades as they usually do in problems like this and where the consequence of the impacts can also vary over several decades. It is better to show the risks in this way than just talk about "expected values," because an "expected

value" really hides the fact that you can get substantially greater or lesser losses with different probabilities. We give our numbers in "expected values" as well, however. Expected values are useful when the degree of variation in both probability and impact are small. But when the degree of variation in impact and probability get this large, it is not necessarily the best measure of assessing the risk we're dealing with.

You notice I've shown uncertainty bounds, and the uncertainty bounds are rather substantial. They can vary by as much as an order of magnitude on either side. In risk analysis, we have generally found that we are not trying to find estimates within an accuracy of a factor of 50% or even a factor of 2. Very often, even with substantially greater uncertainties, very useful decisions can be made. As you will see later on, when you compare that risk profile with the uncertainties against other risk profiles A and B in Figure 6 (comparative profiles might be damage from tornadoes, hurricanes, high winds, or snow storms), you might find that, in spite of the uncertainties, one profile can lie substantially below another. Hence, you would be in a position to say that the risk from this activity, in spite of its uncertainties, is substantially less than the risk from whatever else. You might wish to compare it against manmade risks, because, after all, this is a manmade risk. It is a risk that man imposes on himself. It's not a natural event and you might want to compare it with things like transportation of hazardous chemicals, pesticide programs, nuclear power plants, liquified natural gas transportation.

Now after you've developed the risk profile for the activity of concern, if you find that the risk is unacceptable for whatever reason, you can go back and ask yourself what caused the risk in the area of concern to lie where it does lie. For example, if a decision maker finds that one portion of the risk profile is too high, he can look at options to reduce the risk. He can go back to his calculation to learn what contributed to those points on the curve and he can reduce the risk with risk control options. He can make that curve swing down with the control strategy by either reducing the probability of occurrence or reducing the consequences. This can be done by making changes in operations, by material modification, by engineering fixes or redundancy in the systems, by better inspections, etc.

The final thing I want you to note on Figure 6 is the x-axis, the impact level D. There are dollars, and there are dollars. Now you can talk about the losses caused by lost payroll, you can add to that the cost of repairing the equipment, you can add to that the business interruption which is very often the largest cost, you can add to that legal fees of defending against the accident, and so on. So you must understand very carefully what

dollars you're talking about when you present a risk profile. Somebody might present it only in terms of direct loss incurred. Others, who want to explore the problem in more detail, might present it in terms of loss and the two can differ greatly for the same phenomenon. So keep in mind that the definition of the impact dollar D can vary. Note that for this same carbon-fiber problem, if one wanted to examine shock hazards and portray the shock hazards in terms of expected casualties, it is very easy to do so, and we are going to take a look at that in the next phase of our work. Today, however, we're only going to present our results in terms of national risk profiles with dollar damage as the impact parameter of interest.

I already talked about risk control. Recalling that risk is comprised of two elements, there are two ways in which you can reduce it, as shown in Figure 7. You can either reduce the probability of occurrence through better control systems, or you can reduce the level of impact. Which method you choose depends on how large the risk and benefits are and what the cost effectiveness of the various control strategies is

RISK CONTROL

- REDUCE PROBABILITY OF OCCURRENCE

- REDUCE LEVEL OF IMPACT

Figure 7

Overall Approach

I briefly want to review the overall approach that we used so that you understand how we procedurally went about solving this problem. As illustrated in Figure 8, utilizing aviation statistics, such as the number of accidents that have occurred in the

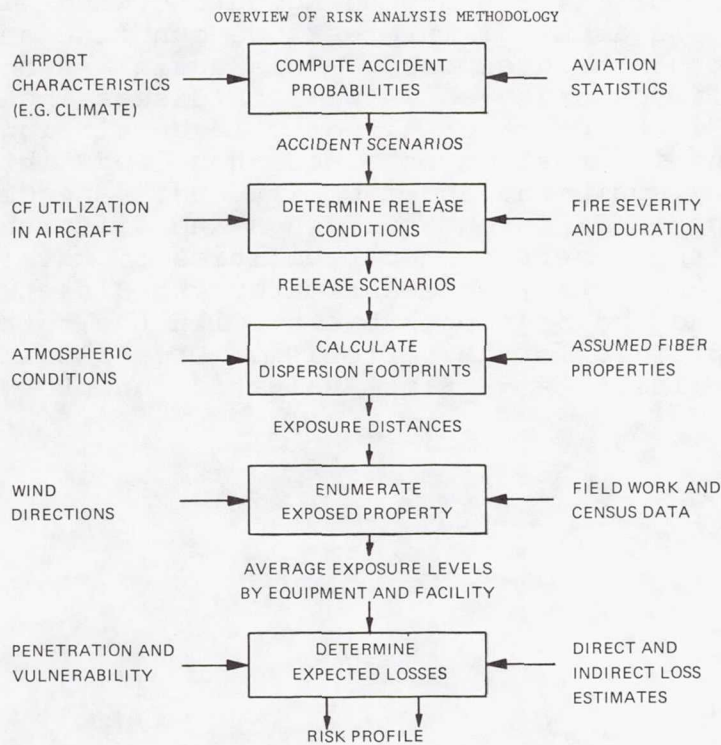

Figure 8

last ten years, the accidents that fall in the fire or fire and explosion category, and the number of operations, and tying those statistics in with airport characteristics (such as the type of climate it might have, the number of operations, any unusual features, the runway orientation, and so on), we compute the accident probability for aircraft. Out of that would be developed a series of accident scenarios which, when tied in with the amount of carbon fiber utilization in aircraft in different years and the fire extent and duration that can occur in accidents of different severity, would determine the release conditions--how much carbon fiber, if any, is released, and in what form. Then, we use that information, along with the prevalent atmospheric condition and the fiber properties (which have been reasonably well measured at this time) to calculate a dispersion footprint. The accident probability

calculation (the top central box in Figure 8) will be addressed in some detail, because it was not addressed in much detail in previous presentations. The release conditions will not be addressed in too much detail because there has been a lot of discussion on the testing that has been done. As far as the dispersion footprint calculation is concerned, we use a method very similar to the one Dr. Wolf Elber talked about, so we are not going to spend too much time discussing that. Once we get the footprint, we can get exposure distances out of it; and depending on the wind direction and actual field work in areas of interest, we can find and enumerate the property that has been exposed. This again was not discussed in too much detail yesterday so we will be discussing it today. We did look at all the 26 major airports in developing our national risk profile. The information obtained then feeds into average exposure levels by equipment and facility and, depending on the transfer functions in different buildings and different systems (which depend on the penetration capabilities of the fibers and the systems they encounter), one estimates the direct and indirect loss. By tying the accident probability with the total loss, one develops a risk profile for this problem. Dr. Fiksel is now going to talk about the last item: Risk Evaluation and Perspective.

Risk Evaluation and Perspective

Joseph Fiksel

I would like to briefly summarize the objectives of our study as shown in figure 9. Our overall objective, as Dr. Kalelkar explained, was to evaluate the risk to the nation due to carbon fiber releases from commercial air carrier accidents involving fires. In order to do this, we gathered data concerning air carrier incidents. Our major source of data was the National Transportation Safety Board statistics which were discussed earlier. We gathered data concerning release and dispersion of fibers, including the experimental results which were referred to by Dr. Vernon Bell in his presentation. We also looked at the potential damage to electronic equipment and identified the types of equipment that might be vulnerable to carbon fibers. We developed methodologies using various techniques including statistical techniques, engineering models, and also a Monte Carlo simulation technique which is really at the heart of our methodology for developing a risk profile. Using the data and the methodology that I've described, we were then able to estimate the national risk.

OBJECTIVES OF ADL STUDY

GATHER DATA CONCERNING

- Air Carrier Incidents Involving Fire
- Release and Dispersion of Carbon Fibers
- Potential Damage to Electronic Equipment

DEVELOP METHODOLOGY USING

- Statistical Techniques
- Engineering Models
- Monte Carlo Simulation

ESTIMATE NATIONAL RISK, INCLUDING

- Projection of CF Market Growth
- Consideration of Major Airport Cities
- Identification of Potentially Vulnerable Facilities

Figure 9

This estimation involved a projection of the growth of the carbon fiber market from the present day up to 1993 and consideration of the major cities around the nation. We identified the large hub airports as described by the FAA, and we examined the

potential risk to those airports in detail. We also looked at the additional airports in a more superficial manner to try to get an idea of the total national risk due to all air carrier operations in the U.S. Finally, we identified the different kinds of vulnerable or potentially vulnerable facilities that could exist. Because of the very large exposure distances involved, and because a carbon fiber cloud may extend over a very wide area, all segments of society and business activity may be influenced by this carbon fiber release.

The projections for utilization of carbon fiber composites in commercial aircraft were provided to us by the airframe manufacturers. We also developed our own projections, and we will soon be coordinating with the airframe manufacturers in trying to improve these projections. These projections are preliminary, but they give a good idea of the magnitude of carbon fiber masses that will be on aircraft in the future. We divided the aircraft that might carry carbon fibers into three classes. Since turbo-props and propeller aircraft in general will not carry fibers, we concentrated on jet aircraft. Three categories were identified: small, medium, and jumbo jets.

On the first line of figure 10, the number of aircraft in service is projected for both 1985 and 1993 in each of these three categories. As shown, the total number of aircraft projected for

PROJECTED CARBON FIBER UTILIZATION					
	YEAR	SIZE OF JET			TOTAL
		SMALL	MEDIUM	JUMBO	
NUMBER OF AIRCRAFT IN SERVICE	1985	825	1980	495	3300
	1993	950	2280	570	3800
NUMBER OF AIRCRAFT CARRYING CF	1985	165	396	163	724
	1993	475	1368	285	2128
CF MASS PER AIRCRAFT (LB.)	1985	234	338	1017	
	1993	1000	1500	4500	

Figure 10

1985 is 3,300. By 1993, we expect 3800 aircraft. The fraction of these aircraft carrying carbon fibers varies from approximately one-quarter of the total fleet in 1985 to half the fleet in 1993. Thus, the total fraction of airplanes carrying fibers will increase. In addition, the amount of carbon fibers per aircraft will tend to increase. For example, on the jumbo jets in 1985, we expect an average of about a thousand pounds of carbon fiber per aircraft; by 1993 this amount is expected to increase to about 4500 pounds per aircraft. Incidentally, for the risk profile that I'm going to show you later, we utilized the 1993 figures. We concentrated on the 1993 data since we were attempting to upper bound the risk that could be caused by the carbon-fiber release phenomenon. It is also possible to generate a 1985 risk profile, but we won't present that today.

The sequence of events that we were obliged to look at in studying the carbon-fiber phenomenon is shown in figure 11. Of course, to get a feeling for the frequency of occurrence of the failure event, we had to look at the total number of air carrier operations and project these out to 1993. Once an air carrier operation occurs, there is a certain chance of an aircraft accident. Therefore, we identified the accident statistics corresponding to the kinds of accidents that we were concerned with, namely those with fire and/or an explosion. In the aftermath of an accident involving an aircraft which carries carbon

SEQUENCE OF EVENTS TO BE MODELLED

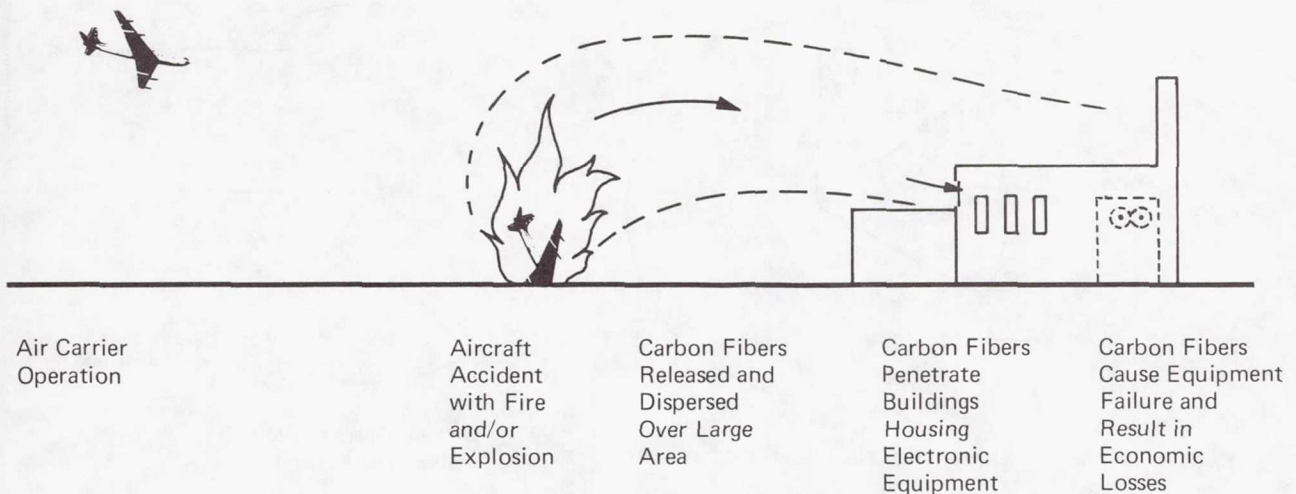
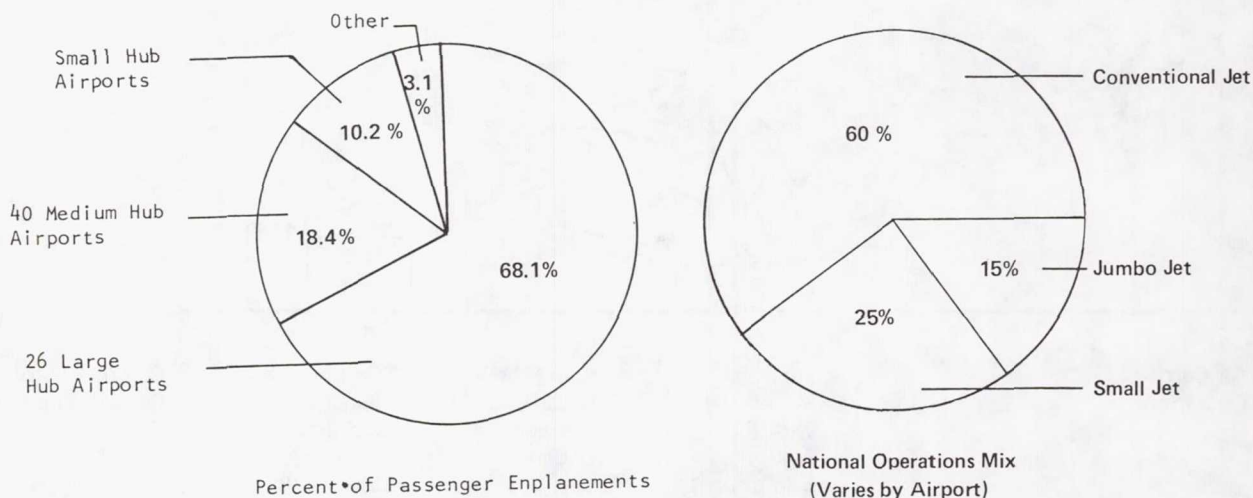

Figure 11

fibers, there is a possibility of the fibers being released and dispersing over a large area. This has already been discussed to a great extent by previous speakers. The fibers can penetrate buildings and damage electronic equipment. This damage can result in economic losses. Now, we'll go through each of these steps in turn and I'll try to summarize some of the results that we've obtained in looking at the different aspects of this release phenomenon.

The first event is the air carrier operation. If you look at figure 12, we have two circle charts. The one on the left indicates the percent of traffic which takes place at the major airports around the nation. As I mentioned, we concentrated on the large hub airports. According to the 1977 FAA statistics, there are approximately 26 such large hub airports, accounting for almost 70% of the total traffic. These large hub airports would therefore account for the majority of the risks. We also looked at the medium and small hub airports to a lesser extent, but our simulation concentrated on these 26 large hub airports. The circle chart on the right shows the national fleet mix projected for 1993 for the three types of jet air carrier operations. The national fleet mix was adjusted for individual airports since each airport has a slightly different fleet mix.

DOMESTIC JET AIR CARRIER OPERATIONS



Source: 1977 Airport Activity Statistics - FAA, CAB

Figure 12

Figure 13 shows results from an extensive analysis of the National Transportation Safety Board data base using both the NTSB tapes and the hard copy records for that subset of the accidents that involved a fire. The data base contains approximately 260 accidents involving either total destruction of the aircraft or substantial damage. Total destruction means that the plane is essentially nonrecoverable. This chart shows the relative frequency of total destruction and substantial damage in the different phases of operation: takeoff, landing, cruise, and static/taxi. The largest potential for total destruction, which is generally the type of accident that involves the largest fires, occurred in the case of landing accidents, but there were also significant possibilities of total destruction in the other phases.

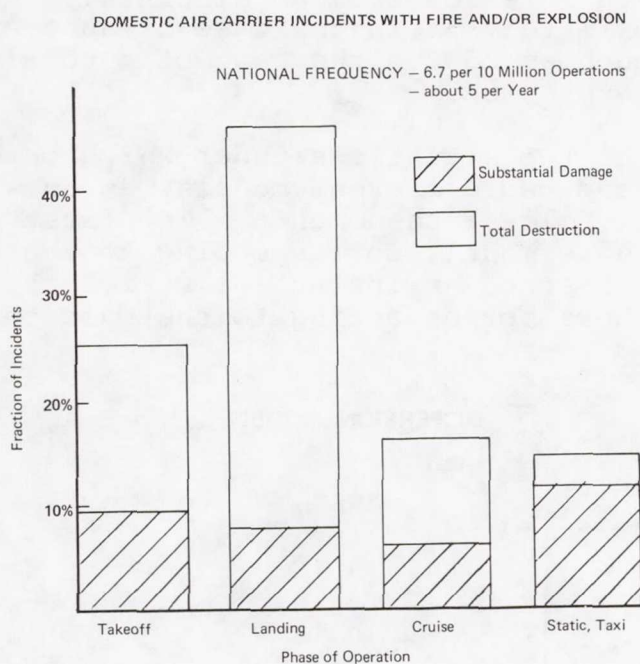

Source: NTSB Accident/Incident Statistics, 1968-1976

Figure 13

Weather conditions at the time of an accident are generally classified into IFR - which stands for Instrument Flight Rules - and VFR - which stands for Visual Flight Rules. There is also a Below-Minimum classification. We took the IFR and Below-Minimum statistics for accidents and compared those against the accidents which occurred during VFR weather. We learned that an accident is eight times more likely in IFR or below-minimum weather. Accordingly, we normalized the national accident frequency (about 6.7 accidents per 10 million operations involving a fire and/or explosion and total or substantial damage, which is equivalent

to about 5 accidents per year) by the IFR/VFR weather frequency in each of the major airports to obtain an adjusted accident rate for each of these airports.

In addition, we estimated the occurrence of explosions in these accidents. Explosions are relatively rare; only about 8% of all accidents with fire result in some kind of explosion. However, it is not a true explosion. Rather, after a period of burn the fire may reach the fuel tanks, at which point there is a very rapid burning or deflagration of the fuel in the fuel tanks, similar to an explosion. This deflagration or "explosion" can cause an agitation of the structure, promoting the release of a large number of fibers. In his presentation, Dr. Vernon Bell showed some of the experimental results that we used to estimate fiber release. Based on these results, we estimated the fraction of fibers that were released from an aircraft. These fractions ranged from approximately 5% in the case of substantial damage accidents to as much as 25% in the case of a total destruction accident with an explosion.

Because of the two situations under which carbon fibers can be released, we used two different models, as shown in figure 14, to account for the release phenomenon. The first model was an instantaneous release model, corresponding to the explosion case. In this model, we assumed an instantaneous release of a certain mass of carbon fibers corresponding to the mass that was onboard

DISPERSION MODELS

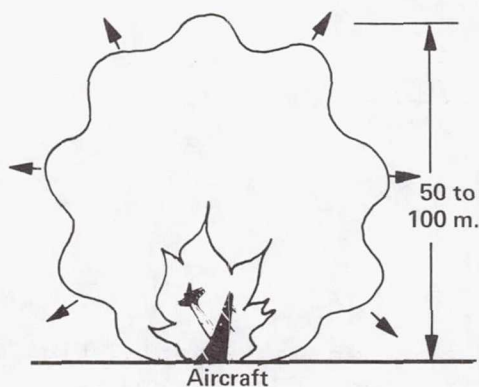

1. Fire followed by a delayed explosion
(instantaneous release model)

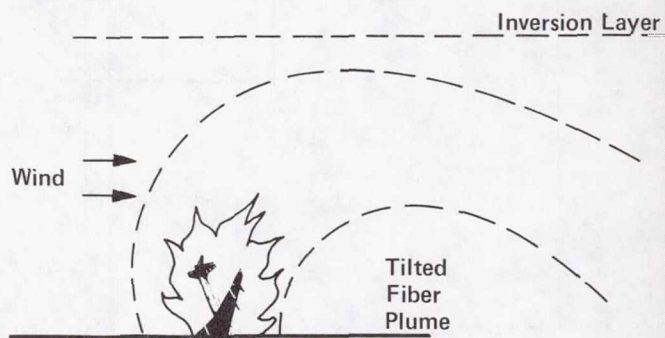

2. Fire Plume Model

Figure 14

the aircraft. A certain percentage of this mass was then assumed to be released as single fibers. The resulting carbon fiber cloud then drifted downwind. The other type of model, in the case where no explosion occurred, is the fire plume model, where the fire causes a plume which rises and reaches a certain maximum height. The carbon fibers are then dispersed downwind. The plume, however, is tilted due to the settling velocity of the fibers. I won't go into the details of these dispersion models, since Dr. Elber gave a very thorough discussion, but these models are similar to the ones that he described and they have been verified in different experimental situations.

Our accident-statistics investigation also permitted us to calculate a probability distribution for the location of an accident and to describe the proportion of the accidents that fell within various distances of the runway. We found that the fraction of accidents that occur off the airport was fairly large in the case of landing accidents, as much as 45%. With most other operational phases, the proportion of accidents occurring off the airport was smaller. In the case of off-airport accidents, as illustrated in Figure 15, we established distributions for the distance and the angle from the runway, and we also utilized runway orientations to pinpoint the location of the accident within the vicinity of each airport. Once the incident location was established, the dispersion model was used to

EXPOSURE FOOTPRINTS AFTER CF RELEASE

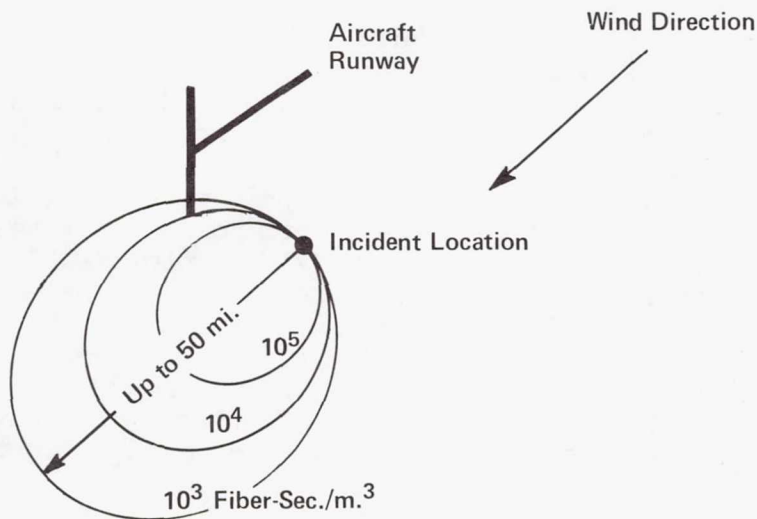

Figure 15

calculate exposure contours in the downwind direction. I should point out that these contours are not drawn to scale. Obviously, the aircraft runway is not that large; the contours can be up to 50 miles in extent, and, generally speaking, they tend to be elongated. That is, they are much longer than they are wide, and not elliptical or almost circular as shown in Figure 15.

Figure 16 gives some sample results from the fire plume model just to give you an indication of the kind of results that we

SAMPLE OUTPUT FROM FIRE PLUME MODEL

Scenario: 500 KG of Carbon Fibers Released Over a 10-Minute Period

EXPOSURE LEVEL	CONTOUR DIMENSIONS (M.)	NEUTRAL ATMOSPHERE 4M./SEC. WIND VELOCITY	MODERATELY STABLE ATMOSPHERE 2M./SEC. WIND VELOCITY
10^5 FIBER-SEC/M ³	NEAREST DISTANCE	0	39,150
	FARTHEST DISTANCE	0	57,150
	MAXIMUM WIDTH	0	4,247
	AREA (KM ²)	0	60
10^3 FIBER-SEC/M ³	NEAREST DISTANCE	6,300	28,150
	FARTHEST DISTANCE	94,300	63,150
	MAXIMUM WIDTH	16,107	8,363
	AREA (KM ²)	1,110	230

Figure 16

obtained for the exposure contour. Two different types of atmospheres are shown: a neutral atmosphere and a moderately stable atmosphere. These are two of the Pasquill-Gifford stability classes. In the case of the neutral atmosphere we had a four meter per second wind velocity; and for the moderately stable atmosphere, a two meter per second wind velocity. In both cases, 500 kilograms of carbon fibers were assumed to be released over a 10 minute period. The distances shown in figure 16 are in meters except for the area which is shown in square kilometers. For example, the 10^5 exposure contour extended over a distance of 57 kilometers and had a maximum width of four kilometers, so it was a fairly elongated contour. Interestingly, in this case the neutral atmosphere showed no 10^5 exposure contour. There are cases in which the maximum exposure will not necessarily exceed 10^4 or 10^5 .

The 10^3 contour for the neutral atmosphere was fairly long. It went out a distance of 94 kilometers, which is slightly in excess of the 50 mile distance that we discussed earlier.

Given these contours, we can establish the exposure in the case of an accident occurring in the vicinity of an airport. Figure 17 gives, as an illustration, a map of Massachusetts showing

DISTRIBUTION OF SECTORS AROUND LOGAN AIRPORT, BOSTON, MASS.



Figure 17

the location of Logan Airport in Boston. We first establish a grid, or a map, in polar coordinates surrounding each major airport. We then place concentric circles at distances of 5, 10, 20, 35, and 50 miles from the airport center and divide the circles into 8 equal segments. This procedure effectively divides the area into 40 sectors. Once the exposure contour is determined and the incident location is identified, we can find the exposure distribution in each of these forty sectors. Notice that if you go out 50 miles, you cover a good half of the state of Massachusetts. Therefore, many different communities are involved. A number of other, smaller, airports are also covered. So, as I mentioned earlier, there are an enormous number of facilities which are potentially vulnerable and subject to exposures of greater than 10^3 carbon fiber seconds per cubic meter.

To establish the kinds of facilities present in exposed areas, we did a great deal of work in terms of field surveys as well as investigations of census data. As shown in figure 18, we

POTENTIALLY VULNERABLE FACILITIES

1. Residences
2. Manufacturers
 - Electronic Equipment
 - Computers
 - Aerospace
3. Transportation
 - Aircraft and Air Traffic Control
 - Mass Transit
 - Motor Vehicles
4. Communication
 - Telephone
 - Radio/TV/Microwave
 - Post Offices
 - Fire/Police
5. Services
 - Financial/Insurance
 - Software/EDP
 - Hospitals
6. General
 - Retail Outlets
 - Office Buildings
 - Industrial Plants

Figure 18

identified the potentially vulnerable facilities in these areas, starting with households. We were able to get a count of the number of households in each geometric sector from 1972 census data. We also used the 1972 census data to examine standard industrial classifications to determine the number of facilities in various types of industries. We enumerated manufacturers of electronic equipment which might be sensitive, including computers and aerospace manufacturers, and we also looked at general manufacturers who might use electronic equipment in process control or for other applications. We looked at the transportation industry; in particular, aircraft and air traffic control were of great interest, and we also examined mass transit systems and motor vehicles. We looked at communications in terms of telephone, radio, T.V., microwave, Post Offices, and fire and police communications. In terms of service industries, we looked at finance and insurance industries, software and electronic data processing centers as well as hospitals. Finally, in the general category, we looked at various types of retail outlets, office buildings and industrial plants corresponding to the general manufacturing category. Mr. Ansel Butterfield described some of the main field surveys that we made. There have been

some additional surveys since then; so that we now have a fairly good coverage of some of the more important facilities in these different categories. As I mentioned, we established a data base which essentially describes the number of facilities existing in the fifty-mile radius area surrounding each of the 26 major airports. I should reiterate that these results are based on 1972 census data and that we did not attempt to project the number of facilities that exist presently into the future.

Given that the facilities have been identified, suppose that a facility is exposed to carbon fibers. How many of these fibers enter the building, and what is the effect of exposure inside the building? Mr. Israel Taback gave us a good discussion of the notion of penetration and transfer functions, so I won't go into that in much detail. The model and main variables are shown in figure 19. The filter efficiencies, window openings, interior dimensions of buildings, ventilation rates, recirculation of air, and infiltration rates through walls and through cracks can all be estimated based upon heating and ventilation handbooks and construction codes, so we can get a fairly good idea of what the rate of entry is for fibers into a building. We can then calculate an inside exposure based upon this information and the outside exposure.

BUILDING PENETRATION MODEL

$$\left(\begin{array}{c} \text{Inside} \\ \text{Exposure} \end{array} \right) = \left(\begin{array}{c} \text{Outside} \\ \text{Exposure} \end{array} \right) \times \left(\begin{array}{c} \text{Transfer} \\ \text{Function} \end{array} \right)$$

TRANSFER FUNCTION DEPENDS ON

- Filter Efficiencies
- Window Openings
- Interior Dimensions
- Ventilation Rates
- Recirculation of Air
- Infiltration Rate

Figure 19

Figure 20 gives an overview of some of the results we got for transfer function, which we call an airborne exposure transfer function (AETF). We've shown a range from minimum to maximum. The reason that we show a range is that there is some uncertainty in the estimation of a transfer function. There are two sources to

AIRBORNE EXPOSURE TRANSFER FUNCTION
OVERVIEW OF RESULTS

AREA DESIGNATION	AETF Range	
	Min.	Max.
AIRCRAFT – CABINS, DOORS OPEN	0.16	0.68
– CABINS, DOORS SHUT	0	9×10^{-3}
– EXTERNAL COMPARTMENTS	10^{-3}	9×10^{-2}
AIRPORT – BAGGAGE AREAS	7×10^{-2}	0.87
– CONTROL TOWERS, WINDOWS SHUT	0	6×10^{-3}
– PASSENGER TERMINALS	0	10^{-3}
COMPUTER ROOMS	0	3×10^{-3}
EMERGENCY GENERATORS	0.1	0.7
HEALTH FACILITIES – GENERAL AREAS, NON SEALED	1.5×10^{-2}	0.44
– OPERATING ROOMS	0	3×10^{-4}
INDUSTRIAL BUILDINGS – OLD BUILDING	0.3	0.7
– MODERN, AVERAGE FILTERS	7×10^{-5}	0.13
OFFICE AREAS – WINDOWS SHUT	4×10^{-4}	7×10^{-2}
RESIDENCES – WINDOWS OPEN	10^{-2}	0.7

Figure 20

this uncertainty. One is the fact that each of the variables is somewhat uncertain. For example, filter efficiencies do have some uncertainty band; they can't be estimated precisely. Another source of uncertainty is that in each type of facility there is an enormous variation in the different building characteristics, from modern buildings to old buildings, from very well controlled buildings to poorly ventilated buildings. So within this range of variation, we're able to estimate a transfer function range from each of the facility categories that I showed earlier. Some samples of the ranges we identified are given in Figure 20. You can see that they range over many orders of magnitude. We looked at aircraft and the airport terminal areas. In computer rooms, for example, you have a fairly low transfer function, anywhere from zero to about 10^{-3} . For residences the transfer function tends to be high, ranging from 10^{-2} to about 0.7 in a situation where it's summer time and all the windows are open.

Figure 21 gives the failure model for electronic equipment. By using this exponential failure distribution and vulnerability

ELECTRONIC EQUIPMENT FAILURE MODEL

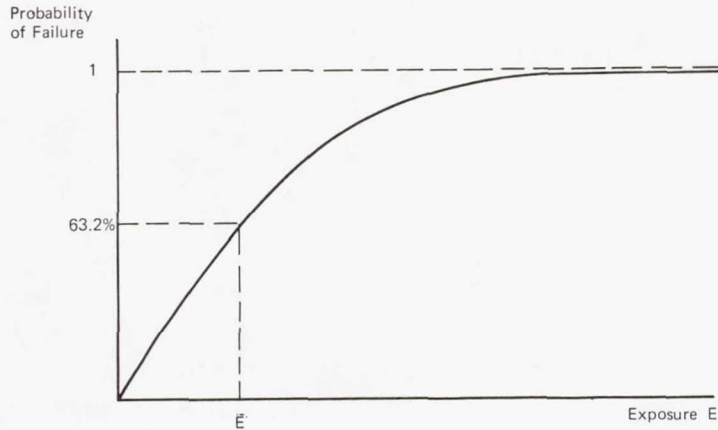

$$\text{Probability of Failure} = 1 - e^{-\frac{E}{\bar{E}}}$$

\bar{E} = Mean Exposure for Failure

EXPOSURE	PERCENT FAILURES
$\bar{E} / 100$	1.0%
$\bar{E} / 10$	9.5%
\bar{E}	63.2%
10 \bar{E}	99.9%

Figure 21

estimates based upon the experimental data that were described by Mr. Israel Taback, we were able to develop a failure distribution for each category of equipment that was identified. It's interesting to note that, on the horizontal axis, at two decades below \bar{E} , the mean exposure for failure, the probability of failure is 0.01; or about 1% of the equipment exposed at that level will fail. At one decade below \bar{E} , about 10% of the equipment will fail. At \bar{E} , about 63% of the equipment will fail. However, at one decade above \bar{E} , nearly all the equipment exposed at that level will fail.

Figure 22 gives some examples of the facility categories that we've identified, along with particular types of equipment that are present in those facility categories and the mean exposure estimates which were derived for those types of equipment. Notice that one column is called "Failure Category". In order to estimate the economic losses, we identified for each type of category what the function was for the equipment within that facility. In other words, how would the failure of equipment affect the operation of the facility as a whole? We identified three such classes, namely equipment which would require only repair in the case of failure, equipment which might disrupt the operation of

SELECTED VULNERABILITY ESTIMATES

Facility Category	Equipment Type	Failure Category	Mean Exposure (Fiber-Sec./M. ³)
HOUSEHOLDS	TV / STEREO	REPAIR	6.4×10^8
AIRPORT CONTROL TOWER	ATC CONSOLES	REPAIR	7×10^5
AIRPORT CONTROL TOWER	ATC COMPUTER	REPAIR	4.9×10^9
SHIPYARDS	CRANES	REPAIR	4.0×10^5
POST OFFICE	ELECTRONIC SORTERS	REPAIR	5.0×10^5
AIRPORT TERMINAL	CRT DISPLAYS	REPAIR	1.6×10^7
MANUFACTURERS	TELEPHONE PBX	DISRUPTIVE	7.0×10^5
AIRCRAFT	AVIONICS INSTRUMENTS	DISRUPTIVE	1.0×10^6
RADIO/TV STATION	CONTROL ROOM	CRITICAL	3.0×10^5
RETAIL OUTLETS	POINT OF SALE TERMINAL	DISRUPTIVE	1.0×10^7
BUSINESS SERVICES	GENERAL OFFICE EQUIP.	DISRUPTIVE	5.0×10^5
HOSPITALS	POWER GENERATOR	REPAIR	9.8×10^5
EDP SERVICES	COMPUTER	CRITICAL	4.9×10^9

Figure 22

the facility (called a disruptive failure), and equipment, such as a control room in a radio/tv station, where, if the equipment fails, the operation is obliged to shut down until the equipment can be repaired. This latter is called a "critical failure". Shown are two types of critical failure: one for the control room and another for the computer in an EDP service industry.

Notice that the exposure estimates for computers to fail are fairly high; they're about 5×10^9 . The reason is that our vulnerability estimate for computers included a transfer function for the computer room. Most facilities have a transfer function corresponding to the building exterior, but, since computer rooms tend to be very well protected, there is an additional transfer function corresponding to the passage of the fibers from outside to inside the computer room and also corresponding to the cabinet protection of the computer. In general the vulnerability estimates tend to range between 10^5 to 10^9 fiber seconds per cubic meter. Generally speaking these values are well above the external exposures that we saw from our dispersion analysis, and, due to the transfer functions, the inside exposures will usually be even further below these levels.

Figure 23 gives economic consequences of the carbon-fiber problem for industries. Recall that we identified three categories of failure type. Corresponding to each of these failure types, we had a different approach towards estimating the economic

ECONOMIC CONSEQUENCES FOR INDUSTRIES

TYPE OF FAILURE	DIRECT LOSSES	INDIRECT LOSSES
Minor	Equipment Repair or Replacement	
Disruptive	Equipment Repair or Replacement	Additional Operating Costs
Critical	Equipment Repair or Replacement	Shutdown, Loss of Revenue

Figure 23

losses. In the case of a minor failure, which amounts to only the repair of the equipment, the cost of the failure was assumed to be the cost of replacing or repairing the equipment. In the case of a disruptive failure we have the equipment repair costs, plus the additional operating costs due to alternate procedures for operating the facility. Although it was assumed that the facility could continue operation while the equipment was being repaired, some additional operational procedures would be necessary. Finally, in the critical failure we assumed a shutdown of the facility, in which case there would be a loss of revenue during the estimated downtime for the equipment under consideration. To get revenue figures and operating cost figures for the various facilities, we used average financial statements for an industry based upon each metropolitan area. We were able to obtain these average financial statements for areas near each of the major airports that we examined.

We've gone through the sequence of events that was to be modeled, and I've shown the approach we've taken towards modeling each step in that procedure, from the initial air carrier

operation to the potential release of fibers, through the penetration, to the possible failure of the equipment, and ultimately the economic losses that could result. Now what did we do with all these data? In her presentation, Dr. Karen Credeur gave a good description of the simulation approach that was used. Our approach was slightly different, but essentially similar in character; it was based upon the roulette wheel analogy that Dr. Credeur described. We used each of the data types that were generated in each of the steps that I described, and input them to a Monte Carlo simulation model, illustrated in figure 24, which performs random draws to simulate the occurrence of an accident.

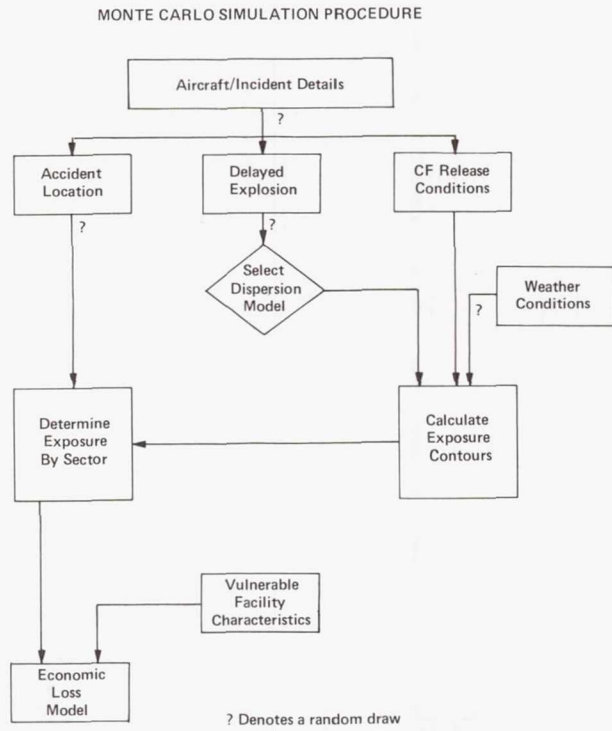

Figure 24

We simulated the occurrence of a large number of accidents for each of the major airports under consideration. We input frequency distributions for each of the different accident characteristics: the aircraft/incident details such as aircraft type, operational category, whether the damage was total destruction or substantial damage--all these details were derived from the aircraft accident statistics. For example, there's a certain chance of total destruction, there's a certain chance that the destruction will be off-airport, there's a certain chance that there will be a fire, and there's a certain chance that there will in fact be an explosion following this fire. A question mark indicates a situation in which we had a random draw

from a frequency distribution. We selected the appropriate dispersion model. For example, if there was a delayed explosion, we selected the instantaneous release model. The carbon fiber release conditions were based upon the aircraft/incident details; these described the mass of fibers that were released. The weather conditions were drawn from data supplied by the National Climatic Service, which describes the wind direction and the atmospheric stability classes at each of the airports under consideration. Given all these details, we then call upon the dispersion model to calculate the exposure contours. The accident or incident location tells us where the exposure contours originate, and we then determine the exposure by sector for each of the 40 sectors surrounding the airport. Once the exposure distribution has been determined, we look at the potentially vulnerable facilities within each of the sectors and calculate the total expected economic losses.

The simulation that I described establishes a distribution for the losses given a single accident at a particular airport. To develop a national risk profile for a single accident, we combined the incident frequencies, as indicated in figure 25. Having the national risk profile for a single incident and knowing the frequency of incidents in the nation, which as I said was approximately 5 per year, we then can calculate two types of representations of the total national risk. One representation

DERIVATION OF NATIONAL RISK PROFILE

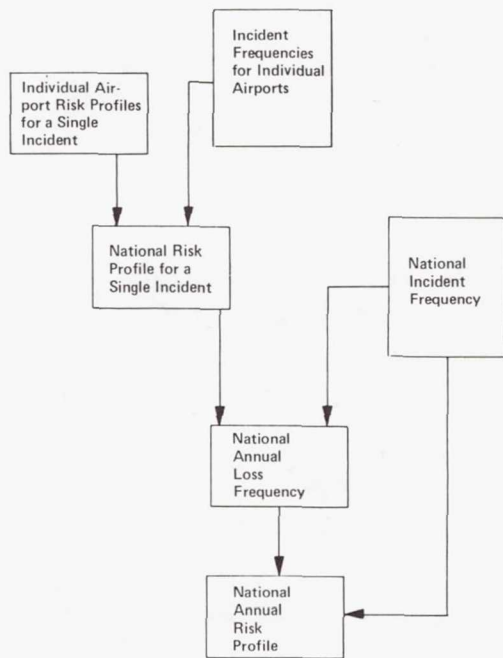

Figure 25

is the national annual loss frequency, which tells us how often events occur with various levels of damage. For example, how often would a ten thousand dollar accident occur? How often would a million dollar accident occur, and so forth? Another representation of the risks, which is a better representation for decision-making purposes, is the national annual risk profile which doesn't look at specific events, but instead gives the range of loss due to carbon fibers for the nation as a whole. This risk representation incorporates the assumption that there may be 1, 2, 3 or more accidents.

Before showing results, however, I want to review the assumptions that enter into this calculation. There are five major assumptions that should be mentioned. These five are shown in figure 26. First, if an aircraft carries composites, we assume that the composite will always be involved in the fire. In fact, this assumption is not necessarily true and the airframe manufacturers are currently investigating the actual probability of the fiber being involved in the fire and thus being released.

MAJOR ASSUMPTIONS

1. IF AN AIRCRAFT CARRIES COMPOSITE, AND A FIRE OCCURS, THE COMPOSITE WILL ALWAYS BE INVOLVED
2. ATMOSPHERIC CONDITIONS REMAIN CONSTANT DURING DISPERSION OF THE CARBON FIBER CLOUD
3. FOR A GIVEN FACILITY CATEGORY, ALL FACILITIES ARE EQUAL IN SIZE, EQUIPMENT INVENTORY, AND FINANCIAL CHARACTERISTICS
4. FAILURES OCCUR IMMEDIATELY AFTER EXPOSURE, WITH INDEPENDENCE AMONG UNITS OF EQUIPMENT
5. SECOND-ORDER IMPACTS OF EQUIPMENT FAILURE ARE NOT INCLUDED IN ECONOMIC LOSS (e.g. interruption of telephone service)

Figure 26

The second assumption is that atmospheric conditions remain constant during the dispersion of the carbon fiber cloud. However, a cloud traveling 50 miles at a speed of about 2 miles per hour can take a day or so and, obviously, the atmospheric conditions are going to change. Therefore, this assumption will

clearly not hold in practice. Nonetheless, since all the different atmospheric conditions will occur with the appropriate frequencies, simulation over a large number of accidents should yield a risk profile that gives a good indication of the potential economic losses.

The third assumption is that, for a given facility category, all facilities are identical in the sense that they have the same revenue, the same size of operation, and the same types of equipment in the plant. In reality we know that there is a wide range of facilities; in his presentation, Mr. Ansel Butterfield demonstrated some of the variation that can occur. However, we assumed an average type of facility for the purpose of calculating economic loss. The fourth assumption is that failures occur immediately after an accident and that the failure of different units is independent. Although Mr. Israel Taback discussed the issue of possible post-exposure vulnerability, we assumed that, if electronic equipment is vulnerable, then the failure will occur immediately after the accident. The independence assumption means that we don't take into account the locations of units within a facility. If the units are located close to one another, then their failures may somehow be correlated. The fifth assumption, which is an important one, concerns the types of losses considered in this analysis. We considered only that we called primary losses, namely those that were a direct outcome of the incident, resulting either in equipment repair costs or in business interruption costs. We did not consider the potential secondary impacts, such as the losses incurred by the interruption of telephone service to a community. In the case of an airport, for example, we did not consider the potential costs of clean-up or decontamination following a carbon fiber exposure. We looked only at the costs of potential failures that would occur.

Figure 27 gives the actual risk profile that was derived. The axis on the left shows the annual probability of losses exceeding a certain amount. The axis at the bottom shows the total losses in dollars. This curve is the risk profile for a single year for the nation as a whole. This means that, in 1993, there is an 80% chance that we will experience losses in excess of 10,000 dollars. Further, moving down the curve about every ten years we would expect to incur a loss of a million dollars or more. Following the curve to the right-hand end, we learn that once about every thousand years, one would expect losses of the order of ten million dollars or more. We also extrapolated the curve further and are in the process of sharpening estimates, so that we can examine the possibility of higher losses at the very low tail end of the risk profile. There may, in fact, be probabilities of the order of 10^{-4} of losses exceeding 20 or 30 million dollars.

ANNUAL RISK PROFILE FOR
CARBON FIBER RELEASES FROM COMMERCIAL AIR CARRIERS
(1993 CF Utilization)

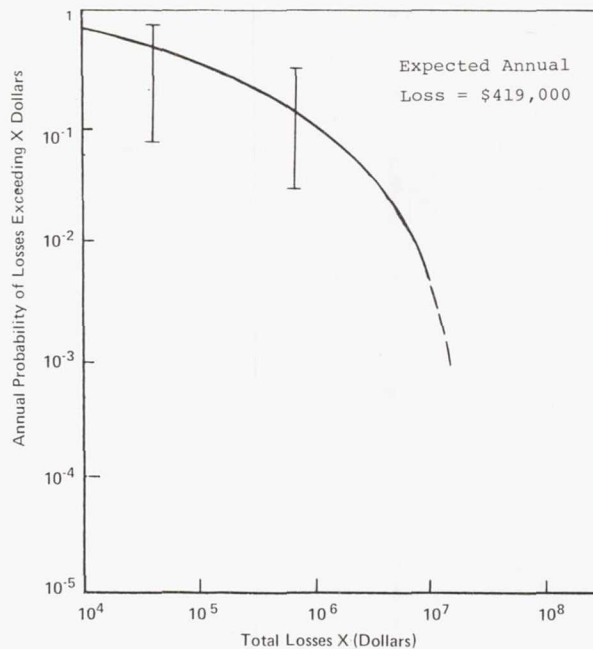

Figure 27

Although the curve in figure 27 is an economic loss profile, it is possible to develop a risk profile showing the potential fatalities due to shock hazards using a very similar procedure. The entire methodology that I've described is applicable to that case, except that, instead of looking at failures of equipment, we would simply look at the probability of a shock hazard for each facility that is examined in the exposed area.

The confidence bounds shown on the profile in figure 27 are estimates and we are currently sharpening these estimates. Although the profile was calculated with 1993 carbon fiber utilization figures, it reflects the 1972 census figures and is expressed in 1977 dollars, so it's a hybrid risk profile. It shows us what the risk would be in 1977 assuming that the number of facilities has remained relatively constant and assuming that airplanes today were carrying the kind of fibers that they would in 1993.

We feel that this risk profile is conservative, in the sense that it tends to overestimate the risks rather than underestimate the risks. There are several reasons for this. One is that in most of our release assumptions, we attempted to be on the conservative side. Another is that the building transfer functions

used were in every case at the maximum or high end of the range. On the other hand, although it's a conservative risk profile, secondary losses are not included. It is conceivable that there would be additional losses due to some types of impacts, such as telephone or airport service interruption, which have not yet been quantified, and these inclusions might tend to move the risk profile slightly to the right.

Now, in order to compare our results against risks which have been estimated for other types of disasters or accidents, let's compare against the curves which Dr. Karen Credeur showed previously. These curves, shown in figure 28, are taken from the Reactor Safety Study, the Wash 1400 report. Shown are the curves corresponding to natural events, man-caused events, and nuclear power plants. These curves have different meanings than the risk profile that I showed you a moment ago; they are national annual loss frequencies. They don't show losses to the US as a whole in a given year; instead they show how frequently accidents occur involving various levels of loss. The axis on the left gives the frequency of incidents per year involving dollar damages greater than a certain amount, X. For example, \$10,000 is the lowest level of loss shown and, since a log scale is used, the plot says that we will have approximately two carbon-fiber related accidents per year involving losses of more than \$10,000. As you move down the curve, you find that the frequency of accidents involving losses of greater than a million dollars is

COMPARISON OF RISK PROFILES

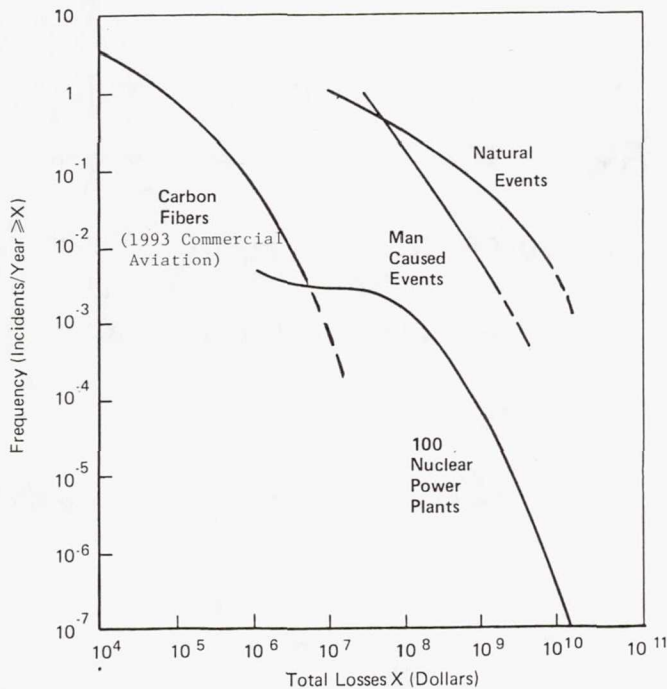

Figure 28

only one in a hundred. In other words, there's a one hundredth chance of an incident each year involving a loss greater than a million dollars.

If you compare the CF curve against the other curves shown in figure 28, you find that it falls well to the left of those curves, indicating that at the same level of frequency the potential losses due to aircraft accident carbon fiber releases are significantly lower. For example, at the 10^{-2} level, in other words, the one accident in a hundred, the estimated damages from carbon fiber are a million or more, but, in the case of the man-caused or natural events, they are considerably more, on the order of \$1 billion. The same is true of the Reactor Safety Study curve for a hundred nuclear power plants. Although there isn't much overlap between the ranges of these two curves, where there is some overlap we again see that for an equivalent low frequency of occurrence, the damage cost is higher for nuclear power plants. For example, for the one accident in a thousand, the damage from carbon fibers is about ten million dollars, whereas an accident involving a nuclear power plant would have damage in excess of a billion dollars.

Figure 29 gives the areas of future effort which will improve the risk estimates that I've shown. These estimates must be considered preliminary due to some of the assumptions that have been

AREAS OF FUTURE EFFORT

1. REFINEMENT OF RELEASE AND DISPERSION ANALYSIS
2. DETAILED ECONOMIC ANALYSIS FOR SPECIFIC BUSINESS CATEGORIES
3. PROJECTING IMPACTS OF GROWTH IN ELECTRONICS INDUSTRY
4. DETERMINATION OF CONFIDENCE BOUNDS FOR RISK PROFILE
5. PERFORM ANALYSIS OF WORST CASE SCENARIO
6. DETAILED ANALYSIS OF ECONOMIC IMPACTS AT AIRPORTS

Figure 29

made. However, there are a number of areas that will assist us in refining the estimates. Note that the expected annual loss on the risk profile is \$419,000 for the nation as a whole due to any accidents that might release carbon fibers. The standard deviation of that risk profile is \$785,000. This large deviation shows a fairly wide variation, and, for this reason, we need a risk profile to examine the possible range of damage that might result.

In the areas of possible future effort, the refinement of the release and dispersion analysis is important, particularly with respect to the release conditions at the time of the accident. In addition, the economic analysis for business categories could be improved by examining specific industries more carefully and by looking at the variation within industries. The impacts of growth in the electronic industry should be accounted for so that we can have a better feeling for what the potentially vulnerable equipment will look like in 1993.

The confidence bound shown on the risk profile can be improved through sensitivity analysis and we're currently in the process of doing that. The sensitivity analysis examines the effect of the uncertainty in each of the variables which enter into the risk profile calculation. We are also in the process of analyzing the worst case scenario. It is possible that there are extremely costly accidents with extremely small probabilities, but which are still realistic and might occur. We will identify the potential worst case which may, in fact, exceed the current value that we estimate for the maximum loss due to any one accident, which is about 10 million dollars. In fact, we may identify accidents which potentially could cause a greater loss, perhaps 20 million dollars or more. Finally, the economic analysis at the airports needs to be improved. In particular, the cost of prevention and decontamination, and the question of the potential failure of airplanes after exposure are still open issues. That concludes our presentation.

QUESTIONS

Question: Question related to (1) differences in the ORI and A. D. Little risk analysis and (2) the sensitivity of the estimates to the amount of fiber released.

Response: With respect to the differences between our estimates, there is some uncertainty, and different methods were used. We feel that our estimate is an accurate reflection of a conservative risk profile. There are confidence bounds on our estimate and I think it's possible that the results shown by the other organization will fall within those confidence bounds. With respect to the second question, the purpose of the sensitivity analysis is to identify the possible

variations in risks that might be due to uncertainty in the variables of interest, for example, the percentage of fibers released. This is still a question, and it is being investigated. We are attempting to see what the effect would be on a risk profile of varying the inputs. You can assume a 20% fiber release or you can assume a 1% release; the question is: What is the impact upon the total risk? As Dr. Kalelkar mentioned earlier, even with substantial uncertainty bounds, the risk profile still allows you to say something about the risks. It still may allow decisions by the appropriate decision makers regarding the risks.

Comment: . . . the risk analysis says the problem falls somewhere between no problem and a major problem.

Response: I don't think we ever said that there was a major problem. We're showing that with some probability you could do a million dollars worth of damage. As to whether that's a problem that we should be concerned about or not, we haven't judged.

Response by Israel Taback: I thought the point of the comment was that one of the computations indicated no problem, and the other one did indicate somewhat of a problem. Actually, I'm surprised that the two answers are so close. If you take the ORI Washington statistics and multiply by the ratio of operations in the nation to those in Washington, and then multiply by 10, the difference between 1985 and 1993, the expected values per year come out to be about the same as the ADL number.

Question: Which of the variables which enter into the risks has the greatest effect upon the risks?

Response: We are currently investigating that in a sensitivity analysis and in our final report we will try to indicate which of the variables has the greatest impact. It's a little early to say at this point, but you got some indications from what was shown. For example, the transfer functions vary over 3 to 4 orders of magnitude. As we've indicated, we've always used the highest transfer function in the spirit of trying to be conservative, and get an overestimate initially rather than an underestimate. So that is one area which can influence it. The other is that economic analysis was done in a relatively straightforward manner and requires substantial additional work. The actual losses that might be encountered could be quite different.

We have done some sensitivity analyses on the transfer function, and it turns out that if you go down to the minimum of the range, the expected value of the risk is diminished by about 80%.

Question: I realize for purpose of the analysis that it is necessary to assume as you did, (1) all failures occur immediately, and (2) you can't start out by trying to assess the cost of the secondary failure downstream, such as the cost of being without telephone service or computer service. Yet it seems to me a very real possibility that several hours after the accident or even a day after the accident the redistribution is a very significant problem. You may have a small immediate cost of 10,000 dollars whereas the secondary down the line costs might be millions. Is somebody pursuing that type of analysis to see how severe those problems can be?

Response: Yes, we intend to give that additional thought. We just haven't had a chance to do it all yet. We are pursuing that.

Question: On your third curve from the last, that showed the possible dollar value of each incident, you showed a rather large spread from each of the points. I notice you took the zero as your starting point and for your first spread you went very near the top of the spread and for the second spread you were at the middle. If you had redrawn that curve so you would cross those spreads towards the center of both you would come out more with a straight line so that the future accidents could have amounted to somewhat higher levels of money, instead of one times ten to the sixth perhaps closer to ten to the seventh or eighth. I was just curious why you chose to draw more a downward pointing curve rather than more of a straight line?

Response: Well, there are two parts to that answer. If you're talking about the risk profile itself, you realize that on the left-hand side, it can never go above one. So, there is a constraining factor there. Then, as Dr. Karen Credeur pointed out, there is a different amount of conservatism applied to different portions of the curve. So sometimes we might have an estimate that could err larger in the upside risk if you will, than in the downside risk, and sometimes the other way around. They don't have to be centrally located in respect to their actual value as shown. It is properly adjusted for that and the curve you saw was our best estimate of the risk.

Question: Question related to the effect of the size of the carbon fibers.

Response: In actuality, fiber size makes some difference in the amount of damage that can occur, the way they disperse, and so on. In this analysis, we assumed that they were

between 7 and 10 millimeters long.

Another open area which I guess we neglected to mention is the fact that we were dealing really with dispersion of single fibers. It was pointed out in previous presentations that you can have lint or clumps; this has not been looked at.

CONCLUSIONS

Robert J. Huston
 Manager, Graphite Fibers Risk Analysis Program Office
 NASA Langley Research Center

I would now like to summarize. Referring to figure 1, we have developed and exercised a risk analysis method. You should recognize, and I want to emphasize, that our risk estimates are very preliminary. Sensitivity analysis has not been done. Only civil transport aircraft accidents have been considered as a source of accidentally released graphite fibers. We intend to study the question of the potential release of graphite fibers from accidents with general aviation, including helicopters, which is the remaining category of civil aircraft to be considered. Let me add that we do not anticipate a large increase in risk due to this additional source. In fact, I doubt very seriously that it is going to increase by even a factor of two. We have already completed a survey of fire accidents in general aviation. We find that the total empty weight of general aviation aircraft that are involved in fire accidents, which represents an upper boundary on the potential carbon fiber released from general aviation, is approximately one-fifth of the empty weight of civil transport aircraft involved in fire. Unless there are some unusual circumstances when we consider a large number of small sources, we may already have at least an order of magnitude estimate on the total risk by studying air transport aircraft alone.

CONFERENCE SUMMARY

A RISK ANALYSIS METHOD HAS BEEN EXERCISED
 RISK ESTIMATES ARE VERY PRELIMINARY
 SENSITIVITY ANALYSIS HAS NOT BEEN DONE
 ONLY TRANSPORT AIRCRAFT ACCIDENTS HAVE BEEN CONSIDERED AS A SOURCE

DATA BASE IS STILL SPARSE - FURTHER STUDY NEEDED IN THE FOLLOWING AREAS
 FIBER RELEASE FROM LARGE FIRES
 POWER GENERATION AND DISTRIBUTION VULNERABILITY
 EQUIPMENT VULNERABILITY (WITH REALISTIC FIBER LENGTH SPECTRA)
 INDUSTRIAL FACILITY VULNERABILITY
 COSTING TECHNIQUES

SOME ELEMENTS ARE STILL UNDER DEVELOPMENT. I.E.:
 FIRE PLUME - DISPERSION MODELS
 FIBER LIFE - REDISPERSION DATA

Figure 1

With reference to our data base, further study is needed in a number of areas. For example, both ORI and A. D. Little assumed that from 5 to 25 percent of the carbon fiber in an aircraft would be released in a crash. However, in Dr. Bell's presentation, he points out that, in the case of fire accidents, approximately 1 percent or less of the fibers might be released. In the case of fire followed by an explosion, 10 percent of the weight of carbon might be released as free fibers. Therefore, we should note that considerable conservatism has been included in the current A. D. Little and ORI analyses. As we acquire further data, we may see a further reduction in the risk profiles from this one area alone.

We do not have enough information on power generation and distribution vulnerability. Ansel Butterfield pointed out in his presentation that power distribution was a key item in assessing cost impacts on factories. We at NASA are heavily dependent upon the activity of the Department of Energy who has responsibility for evaluating carbon fiber effects on power distribution systems. We need to evaluate equipment vulnerability with a more realistic fiber length spectrum. Most of the fiber chamber testing has been done with rather moderate length fibers. Israel Taback showed you the effect on vulnerability of short, medium and long fibers for a very limited sample of equipment. The available vulnerability test data is primarily based on a range from six to ten millimeters. We note that the mean exposure level goes up drastically when short fibers are used in the tests, which, by itself, infers that the probability of damage is less but there may be more fibers. We need to continue studying industrial facility vulnerability to identify key areas for further tests. We need to look at the different approaches to costing in order to have better confidence in the cost impacts of our risk estimates.

Some elements are still under development. Up to now, we are using some simple fire plume models, and they may be adequate in the long run. However, we recognize that a combined fire plume dispersion model, that would also allow computation of the amount of fiber that may be consumed in the actual fire, may show a further reduction in potential damage. To date, the only large outdoor test data we have is the China Lake experiment and it appears that we have had a large amount of fiber burned up in that particular experiment.

The question of fiber life and redispersion was covered in Dr. Elber's presentation. We have to establish what would happen if a small percentage, say one percent of the released fibers, continue to be redispersed from an accident site for a period of time. That effect has not been included in our risk assessment estimates to this point.

Now I am going to go out on a limb and make a judgement about the risk. Our preliminary estimate indicates that the public risk due to accidental release of carbon fiber from air transport aircraft is small. You may judge it in your own way, but I believe that the risk is small with respect to the national benefits that can be obtained from carbon fibers. We should recognize that there is a balance of payment issue involved in terms of foreign sales of commercial aircraft and a significant fuel import and cost savings offered in the application of graphite composites. We do need further work to increase our confidence in this estimate. To reemphasize our schedule, we anticipate completing our "final" risk assessment in 1 year. These conclusions are summarized on figure 2.

CONFERENCE CONCLUSIONS

PRELIMINARY ESTIMATES INDICATE THAT THE PUBLIC RISK DUE TO ACCIDENTAL RELEASE OF
CARBON FIBER FROM AIR TRANSPORT AIRCRAFT IS SMALL

FURTHER WORK IS REQUIRED TO INCREASE OUR CONFIDENCE IN THESE ESTIMATES

Figure 2

Page intentionally left blank

PANEL RESPONSE TO QUESTIONS

Question: Regarding exterior exposure...where can you draw a line between this area as being contaminated and an area outside that for which you need not be concerned?

Response: Israel Taback

If you do it on a computer there's no limit; that is, if you really believe the exponential model, then all the way down to where you drop one fiber on a piece of apparatus, there is some probability of doing some damage. In the real world when the probability of damage gets so small compared to the normal failure rates of equipment, then I think you have to forget it - the equipment would be normally repaired anyhow and the damage would not be noticed. It's a rather difficult question really; as you saw for some of the exposures the failure rates go down as the areas go up, so as you try to extrapolate the total damage you really don't know where to end the computation. Eventually, we know the computations will converge. The answer to your question however, is that with the concept that a single fiber can do damage, you must at least numerically extrapolate it all the way out to where fibers can land.

Question: Question related to describing risk in terms of criticality (i.e. loss of communications say in White House) rather than in terms of dollars.

Response: Bob Huston

We are currently only trying to quantify the risk in terms of cost for the civil community. However, we do need to assess the cost to protect any kind of activity that we think is critical.

Israel Taback

I just wanted to remind the audience that there was a third study underway with respect to other measures of risks, which is being done by George Washington University. We don't have those results in yet but we are going to look at that study to see what other measures should be used in evaluating the risk.

Dr. Karen Credeur

My comments would be to echo these two comments, and also to say that Dr. Kalelkar pointed out in his talk that he will be looking at secondary costs and perhaps some of those secondary costs will get into just the issues you're talking about.

Question: Question regarding relationship of vulnerability to deposition and exposure.

Response: Dr. Wolf Elber

I think in most cases that we've looked at, if you go through an analysis, you'll find that first of all deposition is usually proportional to exposure so that they are related--in most cases they are proportional, so that if we measure the vulnerability in terms of exposure even if inside the box might be deposition critical, we're getting a number which is proportional to the critical term.

Question: There is a substantial amount of fiber that is manufactured overseas. A logical way of shipping it into the United States might be by air and therefore has the case of an accident involving raw unprepregged or raw carbon fiber as a cargo been considered?

Response: Dr. Credeur

We are considering exactly that scenario for a worst case.

Question: Question related to vulnerability of civil aircraft.

Response: Bob Huston

One of our objectives is to look at the need for protection to civil aircraft. We have right now Boeing, Lockheed, and Douglas working with us analyzing all of their air transport aircraft to see if there is a need for protection to air transport aircraft. That is being evaluated right now, not as a part of the input to our risk assessment, but as a separate issue.

Israel Taback:

There is one thing that is in work that I don't think we emphasized previously - that was our concern about general aviation aircraft as well as the larger scheduled commercial aircraft. We are evaluating some of the electronic components that are in the lighter aircraft to see what the extent of risk might be for airplanes parked on the apron. To date, what we've tested hasn't failed, but I suspect that some day we will run into a box that does, then we'll evaluate it.

Question: Is there a size effect below which you would not worry about the vulnerability of electronics?

Response: Israel Taback

Yes, there is a critical size, but I'm afraid it varies with the electronics. First, you always have to worry because of the fact that if you put a lot of fibers into a piece of apparatus, you may bridge the gap with more than one fiber. On the basis that those probabilities are much lower than the bridging of a gap with a single fiber; however, you must usually worry about the relative length of the gaps and the single fibers. For most commercial apparatus where people aren't worried about space, these gaps typically range from a sixteenth of an inch to a quarter of an inch. In military equipment and in space work, where you kind of build the devices from the outside in and room is very important, many of the circuit traces on circuit boards may be as little as ten thousandths of an inch apart, and you must then worry about very short fibers.

Question: Question related to vulnerability sensitivity to fiber length.

Response: Israel Taback

I can only give you a guess at the present. I think the longer fibers would not be a problem for any internal equipment because it's very hard for them to get through filters or even window screens. Short fibers of millimeter length are probably of no concern because they are too short. My guess is that equipment will generally be most vulnerable to fibers ranging in length from 1 to 4 millimeters.

Question: Question related to dispersion sensitivity to fiber length.

Response: Israel Taback

The dispersion doesn't vary much with length. These fibers tend to fall parallel to the ground; and independent of length, they have the same fall velocity.

Question: Question related to fall velocity of fibers.

Response: Bob Huston

They always fall at terminal velocity, if that's what you mean.

Israel Taback

Well I wouldn't say always. I think when the fibers get long enough so that they are essentially not straight lines, so that they have some curvature to them, they'll fall at various velocities with a spectrum of fall rates. As long as they're short and stiff

they seem to be stable in a horizontal attitude and fall at a rate which is independent of length.

Question: Question related to whether or not electrical utilities and substations were considered in the risk assessment.

Response: Dr. Fiksel

In our description of vulnerable facilities I attempted to summarize the categories we looked at and we failed to show the fact that we did look at gas and electric utilities. Those were included.

Question: Is the length of the released fiber related to the length of the fiber in manufacture and would manufacturing techniques affect the lengths of released fibers?

Response: Dr. Vernon Bell

I believe the only evidence we have seen that that might be so, first of all, is in the burning and explosion of woven composites where you have crossovers during the weaving process and there may be weaknesses built into the fiber, thus causing it to break up prematurely into short fibers. The other exception seems to be the long fibrous particulate strips which came off in the outdoor spoiler fire at China Lake where the long strips seem to be quite closely related to the lengths and dimensions of the composites in the spoilers' skins.

Question: Have you done any tests on chopped fibers?

Response: Dr. Vernon Bell

No, we have not. We have sure thought about it because many applications will involve chopped fibers. The fiber is already cut to size once you have burned the resin off. There are some problems with mounting such a type of composite and holding the fibrous residue before you can impact in some fashion. But we are still thinking about doing that.

Question: Have you tried to compare the incident with the incinerator incident of several years ago?

Response: Bob Huston

The answer is no, but we have thought of it and we would like to get the appropriate data. We believe that if we could get the appropriate data from the incinerator incident that we could make a good attempt at predicting what happened.

Question: The statement was made that you did look at the power generation--distribution systems. Could you give us some idea of the . . (vulnerability estimates). . . in terms of transfer function or the sensitivity of this type of equipment?

Response: Dr. Fiksel

I do not have the detailed figures in my head, but I could show them to you afterwards. We considered several different types of equipment, including the switch room and switching apparatus.

Dr. Kalelkar

As far as outdoor equipment is concerned, the clumps and the larger pieces are the ones to be more concerned about. As yet, those have not been incorporated in our analysis.

Question: There has been very little mention of ground transportation vulnerability in the risk assessment. The implication is that ground transportation is not vulnerable. Is that true?

Response: Dr. Leon Pocinki

We did not include it in the calculations we showed, primarily because of the tremendous impact on our thinking of a recent strike of the metro system in Washington. This strike ended up causing some inconvenience to the public, but not much else.

Dr. Fiksel

In our study, the major ground transportation systems that we had identified as being vulnerable were the modern mass transit systems which have electronic controls, such as the Washington subway. There is also a subway system in Boston, where we did include some estimates for vulnerability of the control apparatus.

Question: Is it possible that we can expect soon to have some sort of standardized test plans so the manufacturer can say "Here is my gadget or what have you. I would like to get it tested." Can I then take the results of that (to determine the source potential of the part) and feed it into all these models and what have you?

Response: Dr. Vernon Bell

Yes, at one time the military services had a little gadget which they hoped to use for detection of carbon fibers that were on the loose. I'm not sure what the status of that is. I think it is available. Whether it's been developed sufficiently to pass on, I'm not sure. We do have an activity going within the NASA program, in particular with Jet Propulsion Laboratory, who is trying to come up with a small, fairly portable device which could hopefully be used to not only detect and count but also perhaps measure the sizes of fibers. It was not intended for that purpose and it's still in the very early stages, but, if we're very fortunate, perhaps it could lead to something of that nature.

Bob Huston

Let me also point out that in the alternate materials program there is an intent to provide a standardized burn test, so that material A and material B, tested at two different places, give comparable test results.

Question: Question for Dr. Bell. Correct me if I have this wrong. The woven fabric panels worked very good from a burn only and burn plus a moderate explosion but in a severe explosion they looked worse than the unidirectional and cross ply laminates.

Response: Dr. Vernon Bell

For the woven fabric, the woven material seemed to resist burn and burn plus small impact reasonably well. However, the case of the burn and the high impact or explosion seemed to lead to more individual fibers.

Question: Question related to the fiber lengths used in the vulnerability testing.

Response: Israel Taback

Regarding the fiber lengths, I tried to give you some idea on the slide - they range from about 3 at the low end to about 12 millimeters at the high end. I designated them as being small, medium, and large. Those tests were performed, quite a number of them, here at Langley Research Center. We have a small test chamber. They were performed by carefully injecting fibers that were cut to size into a room at the best uniform concentration we could and testing the equipment in as close to the use condition as we could. That is, if it had a ventilating fan, that was on; if it was thermally ventilated, that's the way it was tested.

Question: What were the sample sizes?

Response: Israel Taback

Actually its the test numbers that I think you're interested in. After any failure the equipment was cleaned and repaired if it needed a repair. The normal number of tests was of the order of six and ranged to as much as perhaps 20 or so on one specific type of equipment.

Question: Was vulnerability testing conducted with a spectrum of fiber lengths?

Response: Israel Taback

At present, we have never used a mixed spectrum. The fibers have been cut to specified lengths and then tested one length at a time.

Question: You mentioned the maximum anticipated cost for an accident worst case situation as 12 million dollars possibly. Looking at the Tenerife situation where the damage cost of one of the airplanes involved was substantially less than the insurance associated with the problem, I am wondering if it would be worthwhile to plot on your last plot, where you show the effect of tornadoes and other weather conditions, etc, the total cost of an airplane accident so that you might get a barometer for the insurance rate increase and also possibly show better the real effects of graphite fibers.

Response: Dr. Kalelkar

In other words, you would like to see the incremental addition in loss of carbon fiber being utilized in connection with an airplane accident. Certainly we can do that and you will see something like that before we get finished with our study. However, I want to point out to you that from the point of view of the people who suffer the risk, the people who fly in an airplane that gets in an accident do so on a voluntary basis, but the people who get hit by the carbon fiber in the aftermath of such an accident take on that risk on an involuntary basis, so that the comparison has to be made rather carefully. From the point of view of people who live miles away from that accident, the only reason that accident affected them is because of carbon fiber composites and, from their perspective, they wouldn't be that interested in the differential between the carbon fiber cost and the total cost.

Dr. Karen Credeur

There's another point, and that is that sometimes when you get into insurance costs and liability suits, you get into the question of costing human life. That question gets into a lot of problems, as some of you may have seen on 60 Minutes some time in the last few months.

Questions: I assume that DOT is following your work and will use your data. How are you interfacing with DOT-automotive, and what are they doing?

Response from the floor: William Leavitt, Department of Transportation

What we're doing is getting acquainted with the problem of expected loadings of cars, vulnerability of the ground transportation system, etc. Hopefully we will get to a point that we can use all the risk techniques that have been developed here and by others that Bob mentioned and feed our inputs into this set of models, if you will. We are probably a year behind Bob's effort.

Bob Huston

Let me say that we are working together. Let me also make a general statement, that may or may not be obvious. In my original list of activities, I mentioned the various DOD laboratories that are supporting us and, of course, we are aware of some of the technical things that they are doing. We've had contact with the Department of Energy. They have some contracted activity. The National Bureau of Standards is doing some work for us and at least one of their people is here today. We hope to mutually support these efforts.

The risk assessment methodology that was presented this morning for commercial aircraft is not going to be terribly different from that for automobiles. Therefore, once the Department of Transportation can define the automobile parameters as inputs to the source data, I think they can generally use the remaining methodology.

Question: Is there any indication as to when the automobile industry will be planning to start utilizing carbon fibers, and secondly is there any indication of where, by virtue of the liability associated with fibers?

Response from the floor: William Leavitt, Department of Transportation

The best input we have so far, and most of this has been from Ford, is that they are looking forward to a flange. In particular, the thing that people are talking about is an air conditioning mounting flange in the next couple of years. Bill Burlant has told me that his best guess would be something like five pounds of composites by 1985 or 1990. In other words, it is not very much as things stand right now. If the picture would change, if someone came through with a real breakthrough in terms of cost or in terms of techniques for fabricating the automotive type component, it could be a different ball game. I should also mention that Ford has what they call an experimental lightweight car that has a lot of carbon fiber composites - I think it is 400 pounds: leaf springs, drive shafts, hoods, door reinforcements, a lot of gadgets inside. This is completed. They plan to show it at the SAE show in February in Detroit. But right now it looks like there isn't going to be much carbon fiber composite loading.

Comment from the floor: Four or five pounds per car times the number of cars produced per year is more pounds than are projected for aircraft.

Comment from the floor: This subject has come up in two composite sessions that have been held by the Society of Manufacturing Engineers. In each case, the manufacturer points out very clearly that they are doing a great deal of experimenting with composites in cars, hoods, doors, drive shafts, and push rods. Although this experimentation is very interesting from a test stand point, the key parameters that are affecting the automotive industry are (1) fifty dollars a pound, which is several orders of magnitude higher than the automobile people wanted to pay right now, and (2) gasoline mileage requirements for the year 1985 and subsequently are driving them in the direction of composites, so they are kind of straddling that horse. I don't think we are going to see a large introduction of composites in cars in the very near future.

Question: Is the soot produced by the incomplete combustion of the matrix an electrical problem?

Response: Richard Pride

In the Dahlgren shock tube, we have exposed two of the amplifier units that are on display in the back of the room to approximately one hour of smoke and soot, not from the epoxy matrix, but from the incomplete combustion of the JP-1 fuel, and had no problems whatsoever from that source.

Bob Huston

Dick Heldenfels mentioned yesterday morning at least one incident involving an aircraft that burned and apparently there were some electrical problems downwind of that aircraft. There was no carbon on that aircraft. Apparently there is a potential problem (from other than carbon fibers).

