

De  
N79-24737

QUARTZ CRYSTAL AND SUPERCONDUCTIVE  
RESONATORS AND OSCILLATORS

Raymond J. Besson

Ecole Nationale Supérieure de Chronométrie et de Micromécanique  
La Bouloie - Route de GRAY -  
25030 BESANCON Cédex - FRANCE -

ABSTRACT

Recently, tremendous advance has been made in the field of "quartz crystal and superconductive resonators and oscillators". A review of general related concepts in the field is presented whereas recent achievements are discussed indicating possible trends for immediate future.

INTRODUCTION

This paper, dealing with a very wide subject, addresses various aspects which are not always considered as connected. Our purpose will rather be to provide general concepts and attempt to dig out some underlying ideas or to indicate some tendencies that could be of interest in the near future. Under those conditions details will often be ignored ; we will not pretend to exhaustiveness but rather give a particular point of view, referring when necessary to original or more complete papers. In recent years tremendous advances have been made in oscillators conception (1),(2), in crystal units design and achievement (introduction

of new crystal cuts, new resonators and transducers (3),(4),(5),(6), (7)) and in superconducting oscillators and resonators (8),(9),(10) (achievement of noise floor of  $3 \cdot 10^{-16}$  for times longer than 10 s). Quartz crystals and cavities will be addressed the same way (quartz resonators are ultrasonics cavities). Those advances have been obtained through fundamental and technical achievements as well, and both were needed at the same time and in every related field (resonator theory, material investigation, non linear phenomena, resonator design, crystal orientation, surface decontamination, encapsulation processes and so on). Each aspect has to be considered as important for desired performances (including environmental features).

Piezoelectric resonators and superconducting cavities will first be introduced together with some new concepts in resonator design. This will demonstrate that some interconnection between various fields is needed to really obtain improvements. Some recent results will then be given and a conclusion will be discussed to indicate which improvements can reasonably be expected in the near future.

Next section will give a general presentation of piezoelectric resonators and their evolution pointing out the main difficulties successively met and solved as the technique evolves toward satisfying requirements.

#### I - Importance of the resonator's part

In general a resonator is some device possibly vibrating at various frequencies and exhibiting various losses which makes the vibration look like a damped oscillation versus time. A negative dynamic resistor can, for instance, compensate those losses but a general rule for success is to start with the minimum losses, i.e. the best possible Q factor, and perturb the resonator as little as possible. Electromechanical coupling makes piezoelectric resonators very attractive since it provides easy excitation and detection of some resonances

(nevertheless, as a first approximation, piezoelectricity does not drastically change the problem of the vibrating body). The extremely high Q factors achieved with superconducting cavities make them very attractive resonators which have proved to allow the best stabilities. The possibility of using adequate piezoelectric resonators at low temperatures can be very promising since the Q factor is expected to increase largely.

#### 1/ Brief presentation of piezoelectric resonators

Piezoelectric resonators are solids of given configuration, shape and dimensions prepared from piezoelectric crystals under precise control of geometry and orientation. Only certain vibrations are piezoelectrically driven. Electrodes provide the electric field necessary to excite the desired mechanical resonances (and other through non linear effects). Though, basically, the same phenomena are involved a great difference exists between bulk devices and S.A.W. devices. S.A.W. devices will not be considered in details here, nevertheless it is interesting to point out their interest for high frequencies and probably for short term stability since the energy applied on a S.A.W. resonator can be higher before non linear effects occur. Because of its many advantages, quartz material has not been seriously challenged in most applications. However lithium tantalate and lithium niobate have proved to be attractive in certain applications (filters, S.A.W. devices ...).

Since an excellent review paper on quartz resonators is available (11) and provides all desired references up to 1974, in the present review we shall call attention to some important aspects emphasizing the most evolutionary ones. From the usual equivalent circuit valid around a resonant frequency, let us simply retain here that the intrinsic  $Q_i$  factor of a crystal is given by:

$$Q_i = \frac{\bar{c}}{\omega \eta_s}$$

where -  $\bar{c}$  is the rotated elastic coefficient (piezoelectric effect included)  
 -  $\eta_s$  is the viscosity constant.

Then the Q of an actual resonator depends :

- on the intrinsic  $Q_i$  i.e. on the actual cut, frequency and  $\eta_s$  (a BT cut has basically 1.6 times the Q factor of an AT cut)

- on the construction of the resonator (ideally one would aim to obtain one resonant frequency only and introduce no other losses than material losses).

## 2/ Frequency temperature behaviour. Various cuts

For a bulk resonator, high frequency, thickness shear vibrating the frequency  $f$  at a temperature  $T$  between  $-200^\circ\text{C}$  and  $+200^\circ\text{C}$  is given by :

$$\frac{f - f_0}{f_0} = a (T - T_0) + b(T - T_0)^2 + c(T - T_0)^3$$

where :

$$f = f_0 \text{ for } T = T_0$$

$a, b, c$  are functions of the rotated material constants for a given mode of vibration.

The singly rotated AT cut (C mode vibrating) is one orientation for which :  $a = b = 0$

This cut will provide us with an interesting behaviour versus temperature since two "turn over" points are available on the plot of frequency versus temperature thus giving rise to temperature stabilization. Let us assume now that additional interesting properties are needed. For instance minima non linear effects (13),(14) or indepen-

dance versus stresses in the plane of the cut (4) are desired. One more degree of freedom must be used thus leading to doubly rotated cuts which have already a long story since the first patent was awarded in 1936. Nevertheless the most important advances are recent (and largely due to the efforts of A. Ballato, E. Eernisse and others) and an important industrial development has already been done (the investigators in industry will forgive me not to cite them all).

Similar considerations to those developed for bulk resonators can be developed for S.A.W. devices (15) and give very promising cuts as a result.

### 3/ Investigating the modes of motion

If the crystal vibrates, the corresponding waves propagate and may form standing wave patterns for given frequencies. Those frequencies are resonant frequencies. The corresponding patterns are called resonance of motion. Complete understanding and investigation of those modes are needed for any improvement in quartz crystal design. Usually, the radiofrequency spectrum of a resonator is very complicated (but still does not comprise vibrations which do not give rise to an electric resonance (16)), and its complete investigation needs theoretical developments (17) (18) (19) together with accurate analysis by X ray topography scanning electron microscopy, interferometry, holography or so. In addition linear considerations are not sufficient at all, since linear effect would not account for coupling between modes (16), (19), amplitude frequency effects (14), (20), and so on.

### 4/ Evolution of the resonator design

Piezoelectric resonator has a long story since it began in 1918. Between the two world wars resonators have been developed at a low industrial rate, rather on an artistic basis. World war II has been

the great booster of quartz industry. The most important improvements have been performed by R.A. Sykes who introduced the universal use of coated units in the 1948 and A.W. Warner who achieved in 1952 the design which is still used now without any major change. Then, for a time, improvements have appeared as asymptotical and interest has decreased. Nevertheless, since quartz oscillators are present in almost any frequency control equipment and are really the workhorses of time and frequency, tremendous effort has been continuously done to improve performances. Quartz crystal oscillators already provide us with small, rugged, low consumption, low cost units of excellent short term stability. The main effort has to go toward decreased aging, low amplitude-frequency effect (then as a consequence better short term stability), thermal stability, low thermal transient sensitivity, and low environmental dependance (acceleration, vibration ...).

## II - New concepts in resonators

For somebody who is not too much impressed by the extraordinary amount of available literature on resonators, each step of the resonator design can be reconsidered. This sometimes arises questions which, at first, look almost childish. For example :

Why do crystals have usually circular or rectangular shapes and spherical contours ?

The answer is that quartz does not care but it is usually easier to deal with those shapes or contours. If correctly handled this interrogation can lead to interesting new shapes or contours. Technical feasibility or (and) even tradition often determines the fabrication method. In addition, it is so delicate to make excellent resonators that the slightest change can be critical. This does not encourage the use of new concepts; it promotes the advantages of established procedures. But, theoretical understanding has been considerably improved

and technology has fast evolved. Also, due to an important effort in fundamental understanding of circuits, especially in N.B.S. Boulder, the concept of the oscillator itself has evolved. Improvements on the resonator alone can now clearly be seen and investigated (21), (22), (1). In other words, it is time now to make new steps in progress.

A very promising development has been the introduction of doubly rotated crystals. (3), (4) interesting for their low sensitivities to stresses in cut's plane (4) their excellent thermal behaviour including thermal transient (5) and their low amplitude frequency effect (13).

It is also possible to make drastic changes in the conventional design which obviously exhibits badly or incompletely solved boundary problems, at least to the high degree of perfection we need (a simple calculation indicates that the fact a 5 MHz crystal keeps its frequency inside the bandwidth means the thickness or equivalent thickness of resonator does not vary more than  $7 \text{ \AA}$  ).

Now, let us see some problems of the conventional design.

In the usual manufacturing process of a plated crystal, a thin metallic film (gold, silver, aluminium or copper) is deposited on to contoured crystal surfaces which have been previously either polished or etched. Usually the crystal is cemented to thin nickel ribbon fixations, T.C. bonded or electrobonded.

Plating should be considered first since its effects occur in the very energy trapping zone. Nevertheless the stress relaxation in the mounting structure and the contamination which is caused by the bonding process cannot be ignored.

Plating is always a very rough process for the crystal surface neighbourhood. The crystalline arrangement is partly upset, piezoelectric properties are locally modified, metallic ions penetrate inside the crystal thereby generating further ion migration. The surface of the crystal is drastically perturbed and the perturbation will not be

constant versus time so giving rise to further frequency drift. At the same time, thin film stresses cause a non negligible frequency shift, which is not stable with time. Several fundamental phenomena being involved it is difficult to predict the exact noise contribution of the plating and the exact frequency drift contribution as well. Nevertheless, it has been possible to prove that small intrinsic stresses correspond to improved aging (23) and that probably the intrinsic aging of quartz material is orders of magnitude lower than aging exhibited by plated units.

At the same time, the Q factor, mainly determined by the internal friction in quartz, is reduced by the damping due to the metal deposited on the surface. But this effect should not be exaggerated, since the Q factor obtained with plated units according to the Warner's design is close to the intrinsic Q factor of the material. Moreover excitation by reduced electrodes, annular electrodes or parallel field technique have been widely used and can be considered as a first attempt to suppress plating (24). At last, it must also be pointed out that, recently, A.G. Smagin (25) obtained very high Q factor with an experimental device using an unplated artificial crystal. Let us consider now the frequency adjustment of plated units. It is a very important problem. Various techniques operating by additional deposition of metal are used, in situ environment or not.

First, the stability of the frequency adjustment, especially in situ environment, is a matter of discussion.

Second, it is generally difficult to adjust the frequency of a given unit to better than one p.p.m of the nominal frequency. (Of course, this does not include the laser machining technique which is only available for glass enclosure type units). Nevertheless a more accurate frequency adjustment is needed for some applications ; so further progress is also desirable in this domain.



New structures, all using uncoated crystals, were outlined and called B.V.A.<sub>n</sub> designs :

- if n is odd, a rather conventional bonding and a special fixation is used.

- if n is even, the design uses improved bonding and mounting.

This denomination indicates two successive steps of our attempt to reduce the crystal's noise and frequency drift contribution. Some of those new designs have already been described elsewhere (6) (7). Let us, simply review some possible solutions trying to point out some useful concepts for each given example.

1/ Usual B.V.A.<sub>2</sub> design (26) (27)

a) Evaluation -

Special emphasis is given to this design which overcomes some difficult problems caused by the conventional evaluation of piezoelectric resonators. We mainly describe here quartz material 5 MHz units but, of course, other piezoelectric materials can be used and resonators of various frequencies have been evaluated.

Our goal was to obtain an "electrodeless" resonator with a mounting exhibiting neither discontinuity nor local stress in the mounting areas. We wanted to obtain a device the frequency of which could easily be adjusted by means of a series capacitance. Then a large gap capacitance is suitable i.e. electrodes have to be located very close to the active surface of the wafer (in the micron range or even the 10 microns range). Also, and this is very important too, we planned to obtain mounting areas very accurately located and mounting means precisely known.

The B.V.A.<sub>2</sub> resonator is represented by the schemes of Fig. 1 - Fig.2.

It includes :

- a vibrating quartz crystal, ref.C, the surface of which has been very carefully prepared. The active part of the crystal is connected to the dormant part by little quartz "bridges" very precisely made and located.

- a quartz condenser made of two disks (ref.  $D_1$  and  $D_2$ ) of the same cut and orientation on which the electrodes are deposited.

- means to maintain the condenser and crystal tightly together.

- a metallic experimental enclosure which is sealed by a pinch off process.

It must be pointed out that some construction parameters, especially the support configuration parameters, can be, using this design, very precisely known. Also since the crystal is "electrodeless" and uses an all quartz structure it is very suitable for low temperature applications. Moreover, the electrodes may be deposited on insulators which have been given a curvature different from the crystal surface's. This feature gives access to additional possibilities and may be used to modify Q factor, motional parameters series resistance and frequency amplitude effect.

Such a resonator, being entirely different from a conventional resonator, needs theoretical and technical studies specially devoted to it.

The original part of the crystal evaluation will only be described here. By use of ultrasonic machining and precise lapping little bridges are left between the external dormant part of the crystal and the internal vibrating part. Those bridges have a given shape, a given thickness, a given length. The bridges can be very precisely located with respect to the thickness of the crystal (accuracy of the location :  $\pm 10\mu$ ). Their angular position can also be very precisely

known ( $\pm 0.04^\circ$ ). Of course, the technique has to be perfectly mastered (for instance, avoiding a conical ultrasonic machining is not immediate) but, with sufficient experience, the process can be considered as sure, rapid (2 or 3 minutes) and very accurate. As a consequence the middle part of the bridges can be located at the very nodes of vibration. Also, unwanted modes can be better eliminated. Since the thickness in the middle part of the bridges has ranged from  $50\mu$  to  $1200\mu$  (the usual is approximately  $200\mu$ ) the bridges are not especially brittle. Any number of bridges can be left. Especially one single bridge, covering the full  $360^\circ$  angle, may be directly lapped so avoiding the ultrasonic machining.

It must be pointed out that the machining does not destroy the material from the cristallographic point of view.

Moreover, no additional stresses are left by the machining if the quartz wafer is subjected, prior to mounting, to annealing at about  $480^\circ\text{C}$ , followed by a very slight surface attack with bifluoride.

The length and thickness of the bridges have been theoretically studied. Assuming a flexure vibration of the bridge, it is found that a length of 2 mm and a thickness of 0.2 mm is a good compromise between a weak static strain and a minimum acoustical energy transmission between the vibrating and dormant part of the crystal (5 MHz fifth overtone).

The reflection of the elastic waves is not influenced by the position of the electrodes with regard to the crystal surface. It mainly depends on phenomena which occur in the boundary neighbourhood and which are due to crystalline modifications caused by machining processes and surface preparation.

The sample surface is carefully lapped and polished, so as to reduce the layer in which acoustic dissipation occurs. Defects due to machining processes are carefully investigated (X ray topography, electron microscopy and so on) so as to define the best procedures. As far as possible, we operate in a clean room atmosphere, try to process the

crystal in dry nitrogen and, of course, use the results of recent investigations for cleaning and decontamination (28)(29).

The influence of the gap has been studied. Experimentally, the Q factor is not a constant versus the total gap. The variation depends on the frequency and overtone number of the unit.

Nevertheless an investigation was started and proved that usual equivalent circuit is not sufficient.

So, starting from the exact expression of the current, we computed the Q factor versus the gap (assuming a plane infinite plate) and found a variation which gives a better account of the results (30).

Actually, a compromise must be chosen. The series resistance and the motional inductance strongly increase with the gap. Also, the frequency of the unit must be easily adjusted by a series capacitance ; so very thin gaps are suitable.

But the mechanical stability of the gap thickness is to be considered too, if ultrastable units are desired. For a 5 MHz fifth overtone we use gaps in the micron or 10 microns range. Nevertheless for resonators on the fundamental mode the gap can be larger.

Usually, the gaps are made by a special lapping process which affects the central area of  $D_1$  and  $D_2$  (see Fig.1). They can also be made by nickel electrodeposition. It must be pointed out that slightly different gaps can be made so giving access to very precise frequency adjustment (1 Hz for a 5 MHz fifth overtone unit).

#### b) Properties of B.V.A.<sub>2</sub> design -

This design has now been extensively studied for more than five years. To summarize, it should be said that improvements of almost an order of magnitude over the conventional design seem possible for short term stability, long term drift and g sensitivity as well. At this point, the following results have already been obtained :

- stabilities  $\sigma_y(\tau)$  of 5 to  $6 \cdot 10^{-14}$  over 128 s or so (2),

- drift rate of 3 to  $5 \cdot 10^{-12}$  per day after one or several months,

- maximal g sensitivity of  $2 \cdot 10^{-10}$ /g for an  $\Lambda^{\tau}$  cut (31).

Nevertheless, the design cannot be considered as having reached its final state and some more improvements are possible. Of course, it must also be pointed out that some properties (such as thermal properties) can be totally different from the corresponding properties in a conventional unit.

### 2/ B.V.A.<sub>3</sub> design (27)

Since the B.V.A.<sub>3</sub> design is an improvement of the B.V.A.<sub>1</sub> design it will be very rapidly described using the scheme of Fig. 3. The vibrating quartz crystal C of a given cut, orientation, geometrical shape (in a Fig.3 a planoconvex disk) is, for instance, TC bonded (3 or even 4 bonding points ref.T) to the lower disk D<sub>1</sub> (which has been given a curvature identical to the curvature of the wafer's lower surface). D<sub>1</sub> is usually made out of quartz of the same cut and orientation. The electrodes are evaporated on the lower disk D<sub>1</sub> and the upper disk D<sub>21</sub> or D<sub>22</sub>. The upper disk is not necessarily made out of quartz and may have any radius of curvature. The intermediate ring R determines the upper gap giving access to frequency adjustment or modulation. Compared to B.V.A.<sub>1</sub> type this design has mainly the same properties but the characteristic features are greatly improved in severe environmental conditions.

### 3/ B.V.A. Dual Resonator (32)

The scheme of Fig.4 shows a new design comprising basically 2 B.V.A. resonators R<sub>1</sub> and R<sub>2</sub>. If the axis are respectively orientated as indicated of Fig.4 (drawn for the AT cut case) very low g sensitivity

is obtained. In addition,  $R_1$  and  $R_2$  can obviously be used in parallel or in series ; also they can have identical or different frequencies. In the parallel case the frequency difference basically does not depend on temperature if  $R_1$  and  $R_2$  are similar enough (32). Among other advantages this new structure gives  $R_1$  a very precise orientation with respect to  $R_2$  and places  $R_1$  and  $R_2$  in very similar thermal conditions (temperature and temperature gradients).

#### 4/ B.V.A. design for U.H.F. range

The most important advantages of the B.V.A. design appear at high frequencies. In fact in thin or very thin coated units the "electrode effect" is relatively more important. Nevertheless, the usual B.V.A.<sub>2</sub> design is limited toward high frequencies (limitation similar to the limitation of conventional coated units). Then a new design called B.V.A. - U.H.F. has been developed for the U.H.F. range (33). Basically it comprises a very thin B.V.A. vibrating crystal in a reentrant cavity made of quartz. Resonant frequencies in the GHz range have already been obtained.

#### 5/ Reverse structure

it is also perfectly possible to imagine quartz structures with bridge (or bridges) connecting the external vibrating to the internal dormant part (34). This structure gives excellent results with low motional resistance. The mounting in the central dormant part can be reduced to an axis and consequently can be made extremely symmetrical.

### III- Superconducting cavities and crystals at low temperatures -

The analogy between the two subjects is somehow very impressive. Since stabilities down to  $3 \cdot 10^{-16}$  have been demonstrated (10) for the S.C.S.O

(Superconducting Cavity Stabilized Oscillator) by Stein and Turneaure, since low temperature technology is no more a future technology this possible technique has to be considered. Both quartz crystals and superconducting cavities can be used in active oscillators or as passive reference for a free running slave oscillator (in this case all the electronic circuitry will be at room temperature). Both devices are not accurate i.e. they suffer from frequency shift and are used when the knowledge of absolute frequency is not necessary. In fact in both cases, the resonant frequency is determined by the size of the resonator. The Q currently achieved for crystal units 5 MHz are in the range of 2 to  $5 \cdot 10^6$  at room temperature and can reach some  $10^8$  at helium temperature. It is to be pointed out that electrodeless resonators are the best suitable resonators for low temperatures. Superconducting cavities with Q as high as  $10^{11}$  at 8.6 GHz have been used. Whatever are the differences similarities between superconducting cavities and crystal resonators is interesting : even similar techniques are used to evaluate the devices !(chemical polishing, oven stabilization, baking out in inert atmosphere, final preparation in glove boxes and so on). The main advantage of quartz cavities at low temperature could be their small size if it is really demonstrated that properties at helium temperature are excellent, reproducible and not affected by some hysteresis process. In this domain, the advantage of the new B.V.A. technique is obvious.

At this point and for both devices the advantages of passive and active operation can still be discussed. Basically, in active operation, the resonator (or cavity) is coupled to a negative coefficient resistor and in passive operation one can use the fact that the reflection (or transmission) coefficient of the cavity is a rapid function of frequency. A feed back type circuit is used and the high loop gain produces an oscillator whose stability is limited by the frequency fluctuations of the element (in both superconducting cavity and quartz crystal stress relaxation appear to be one important limiting

process).

Of course a passive operation will allow the reference element to be far away or at different conditions with respect to the electronics.

#### IV - About the use of resonant frequencies -

This section will address some basic problems related to the use of resonators giving some references for specific problems of circuits. Actually, the traditional concept of the best quartz oscillators has recently been reconsidered especially in N.B.S. Boulder (Time and frequency standards section). This effort, mainly due to H. Hellwig, S.R. Stein and F.L. Walls, was initiated with passive measurements on crystals in 1974 (21). Actually, passive measurements by Walls and al (on an initial suggestion of D. Halford) demonstrated that the intrinsic noise of the best quartz crystal resonators is significantly less than the noise observed in oscillators employing those resonators. It has been possible to predict the performances of the composite system based on the measured performances of its components (1). Also it has been possible to compare various types of resonators (22), in various conditions, from the noise point of view. In fact one has come to the point where circuit stability can be distinguished from crystal stability. Since superior performances have been demonstrated with a passive reference crystal oscillator (2) we can now determine which problems come from the crystal and which problems are due to the circuit. At this point, we can say that at least some crystals are more stable than others and that it is not obvious to take advantage of superior capabilities of given resonators. It is certainly important to make more investigation on passive and active circuits, assuming the main features and capabilities of the crystal are known by passive methods. Nevertheless, it is still too soon to recommend either passive methods or active ones, at least for any integration time. Anyway, the conclusion is that important work should be performed on cir-



cuits. Also, crystal resonators or cavities should be designed taking into account the knowledge of circuits (the inverse is, of course, also true). It is interesting to point out that apparent asymptotic limits of performances have been observed for one or two decades (some Xtal oscillators, built many years ago, are still among the best ones). Is it completely ridiculous to imagine that the limitation due to Xtal resonators is somehow of the same order of magnitude as the limitation due to electronics? If it was true, the proper answer should be to use at the same time better electronics and better crystal units.

V - Discussion of recent advances, perspective for near future and conclusions -

The recent results obtained by the S.C.S.O. (Superconducting Cavity Stabilized Oscillator) are the most impressive ( $3 \cdot 10^{-16}$  noise floor achievement) and provide us with a strong stimulation for superior performances.

From what has been seen, realistic performances for quartz oscillators (at room temperature) can be expected to be available in the near future. Drifts on the order of  $10^{-12}$ /day, short term stabilities in the  $10^{-14}$  range, acceleration sensitivities of  $2 \cdot 10^{-10}$ /g (AT cut) and  $2 \cdot 10^{-11}$ /g (doubly rotated cut), acceleration sensitivity compensation, very low noise capabilities and excellent spectral purity already seem possible.

Nevertheless various investigations in domains ranging from environmental influence (35)(36)(37)(38)(39)(40)(41)... quartz resonator design, measurement and application (30)(42)(17)(43)(44) ... resonator processing (45)(46)(47)(48)(49)(50) ... fundamental properties of materials (51)(52) ... oscillator design specification and measurement (2)(53)(54)(55) ... are still currently being done and applied. Further advances are still possible on each individual feature; also it can be useful (and not obvious) to obtain excellent performances at

the same time for various features (including environmental sensitivity).

In addition, quartz crystals seem very promising at low temperature for oscillator applications, since very high Q factors are possible especially with the "electrodeless technique". Of course, quartz resonators can also be used (especially doubly rotated cuts) to make very convenient temperature sensors. In this domain the main effort has to go toward very low hysteresis effects and high reproducibility.

Though it has not really been demonstrated yet, the B.V.A. technique should be of interest for this purpose.

Furthermore, it is to be pointed out that the concept of composite oscillator systems (56) or composite resonator systems (32) is a very powerful tool to meet the severe requirements which will be needed in near future.

#### Acknowledgements -

The author, currently guest worker in "Time and Frequency Standards Section" N.B.S. Boulder, would like to thank especially Drs H. Hellwig, S.R. Stein, F.L. Walls and C.M. Manney for many helpful discussions. He highly appreciates the opportunity that was given to him to work in this laboratory environment and would like to thank the organizations that made it possible (in France D.R.E.T. and Ministry of Universities, in the U.S. National Bureau of Standards, U.S. Department of Commerce).

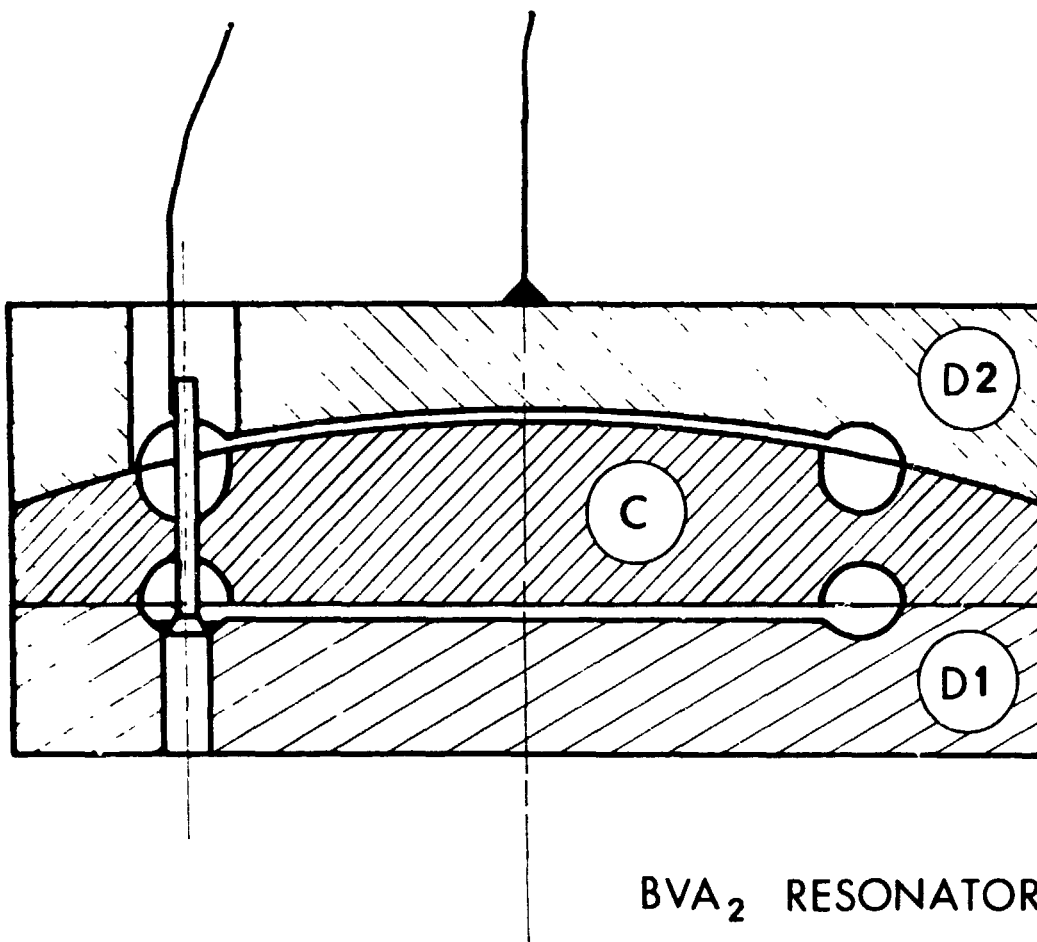

BVA<sub>2</sub> RESONATOR

FIG - 1

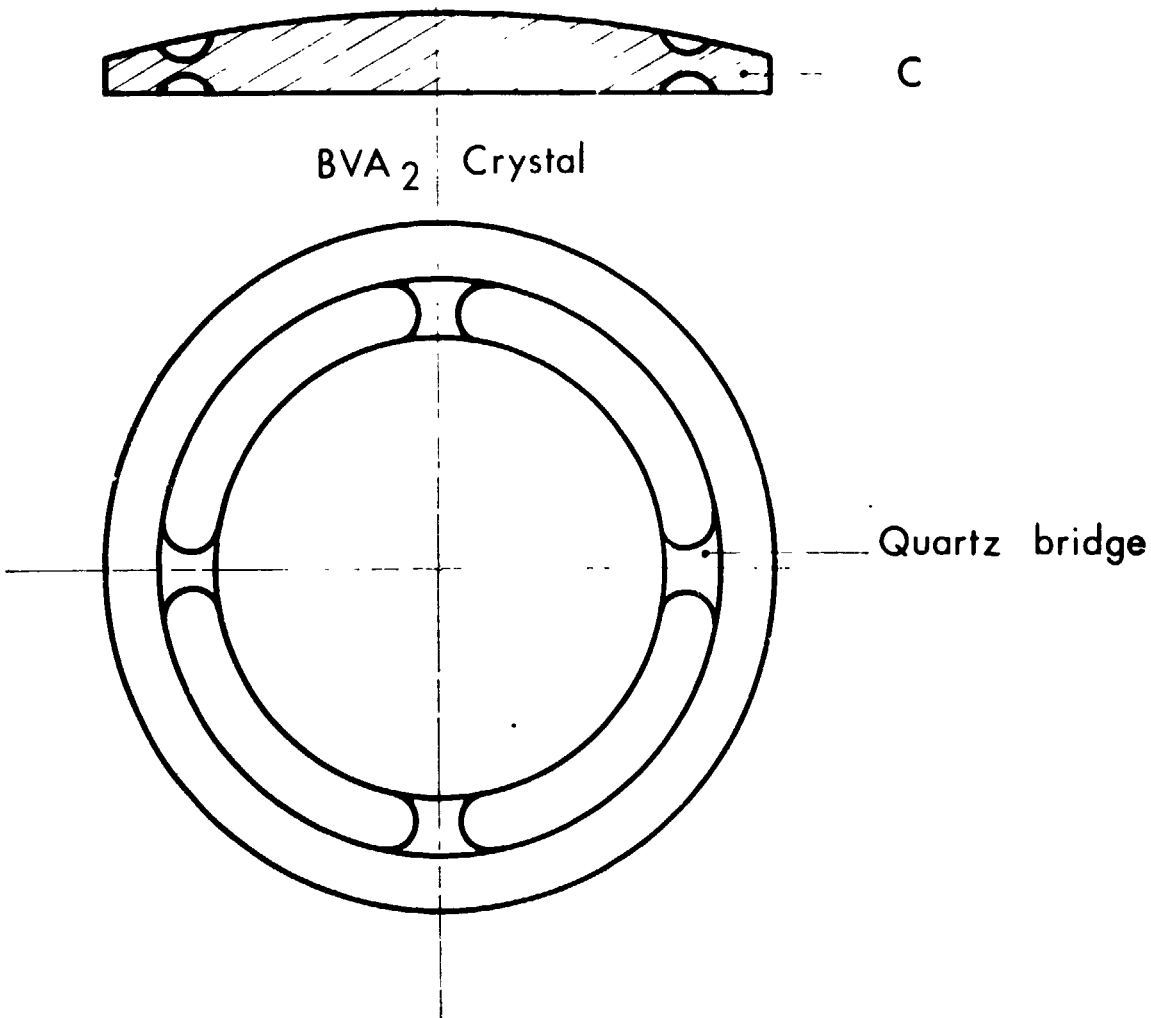

FIG-2

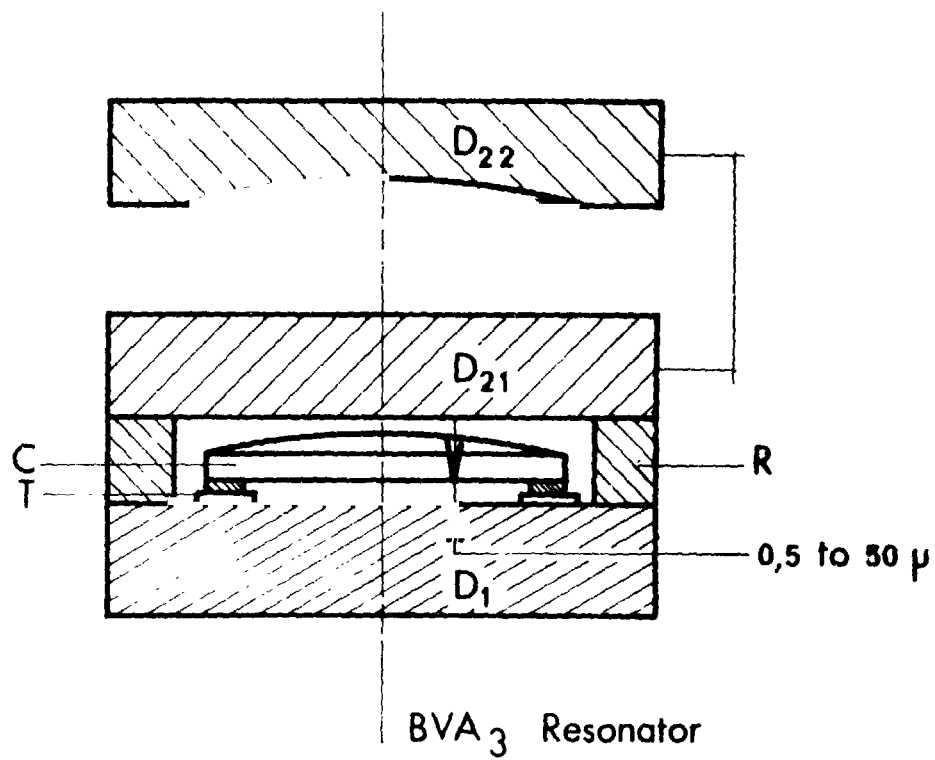

FIG 3

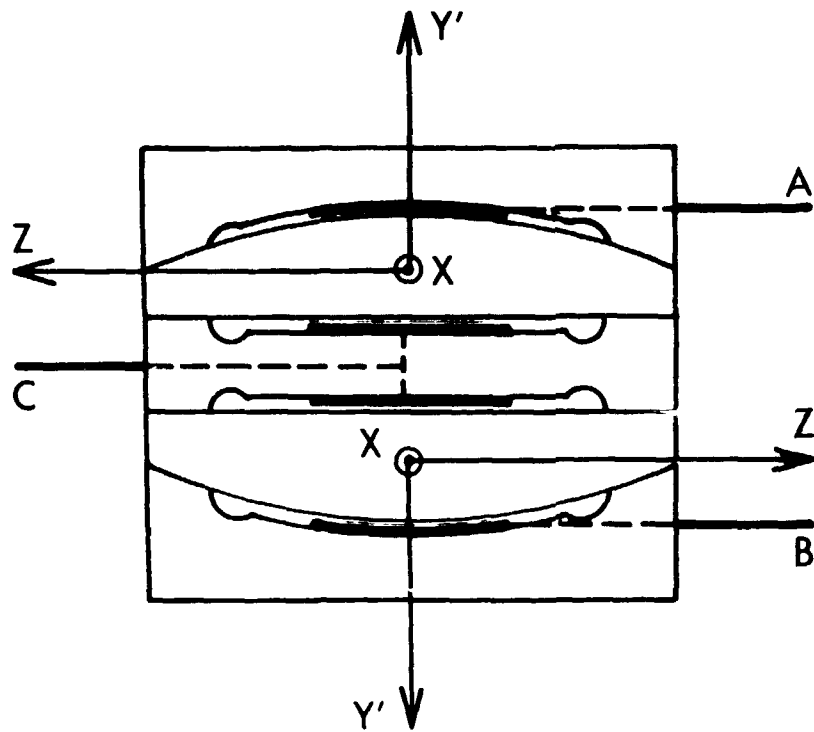

FIG 4

## REFERENCES -

- (1) - F.L. Walls - S.R. Stein -  
"A frequency lock system of improved quartz crystal oscillator performance" -  
I.E.E.E. Trans. Instrum. Meas. - IM - 27, 249 - 252 (1978).
- (2) - S.R. Stein - C.M. Manney, Jr, F.L. Walls, J.E. Gray - N.B.S.  
and R. J. Besson E.N.S.C.M.B. -  
"A systems approach to high performance oscillators"  
Proc. 32<sup>nd</sup> A.F.C.S. - pp. 527 - 530 (1978)
- (3) - A. Ballato -  
"Doubly rotated thickness mode plate vibrators"  
Physical Acoustics - Vol. XIII - pp. 115-181 - Ac. Press NY.  
(1978)
- (4) - E.P. Eer Nisse -  
"Quartz Resonator Frequency shifts arising from electrode stress"  
Proc. 29<sup>th</sup> A.F.C.S. - pp. 1 - 4 (1975) and "Calculations on the stress compensated (S.C.-cut) quartz resonator" - Proc. 30<sup>th</sup> A.F.C.S. pp 8 - 11 (1976)
- (5) - J. Kusters -  
"Transient thermal compensation for quartz resonators"  
I.E.E.E. Trans. Sonics and Ultrasonics SU-23 pp-273 - 276  
(1976)
- (6) - R.J. Besson -  
"A new piezoelectric resonator design"  
Proc. 30<sup>th</sup> - A.F.C.S. - pp. 78 - 83 (1976)
- (7) - R.J. Besson -  
"A new electrodeless resonator design"  
Proc. 31<sup>rst</sup> - A.F.C.S. pp - 147 - 152 (1977)
- (8) - S.R. Stein -  
"Application of superconductivity to precision oscillators"  
Proc. 29<sup>th</sup> - A.F.C.S. - pp. 321 - 327.
- (9) - J.P. Turneaure in Proc. 1972 - Applied Superconductivity Conference (I.E.E.E. - New York 1972) p. 621.
- (10) - S.R. Stein and J.P. Turneaure in Future Trends in Superconductive Electronics (A.I.P. New York - 1978) pp. 192 - 213.

- (11) - E. Hafner -  
 "Crystal resonators"  
 I.E.E.E. Trans. Sonics and Ultrasonics - Vol. SU 21 N°4  
 pp. 220 - 237 (October 1974)
- (12) - A. Ballato and G.J. Iafrate -  
 "The angular dependence of piezoelectric plate frequencies and  
 their temperature coefficients"  
 Proc. 30<sup>th</sup> - A.F.C.S. - pp. 141 - 156 (1976)
- (13) - J.J. Gagnepain - J.C. Ponçot and C. Pegeot -  
 "Amplitude - Frequency behaviour of doubly rotated quartz reso-  
 nators"  
 Proc. 31<sup>rst</sup> A.F.C.S. - pp. 17 - 22 - (1977)
- (14) - J.J. Gagnepain - R.J. Besson -  
 "Non linear effects in piezoelectric quartz crystals"  
 Physical Acoustics - Vol. XI - Ac. Press - N.Y. (1975)
- (15) - D. Hauden - M. Michel - J.J. Gagnepain -  
 "Higher order temperature coefficients of quartz S.A.W. Oscil-  
 lators"  
 Proc. 32<sup>nd</sup> A.F.C.S. - pp. 77 - 78 - (1978)
- (16) - J.H. Balbi - J.A. Duffaud and R.J. Besson -  
 "A new non linear analysis method and its application to quartz  
 crystal resonator problems"  
 Proc. 32<sup>nd</sup> - A.F.C.S. - pp. 162 - 168 - (1978)
- (17) - H.F. Tiersten - R.C. Smythe -  
 "An analysis of overtone modes in contoured crystal resonators"  
 Proc. 31<sup>st</sup> A.F.C.S. - pp. 44 - 47 - (1977)
- (18) - H.F. Tiersten -  
 "Linear piezoelectric plate vibrations"  
 Plenum Press - (1969)
- (19) - R.D. Mindlin -  
 "An introduction to the mathematical theory of vibrations of  
 elastic plates"  
 US Army Signal Corps - Fort Monmouth - N.J. 1955  
 R.D. Mindlin - W.J. Spencer -  
 "Anharmonic thickness twist overtones of thickness shear and  
 flexural vibrations of rectangular AT cut plates"  
 J. Acoust. Soc. Am 42 p. 1268 (1977)



- (20) - H.F. Tiersten -  
 "Analysis of non linear resonance in rotated Y cut quartz  
 thickness shear resonators"  
 Proc. 29<sup>th</sup> A.F.C.S. - pp. 49 - 53 (1975)
- (21) - A.E. Wainwright - F.L. Walls - W.D. Mc Caa -  
 "Direct measurement of the inherent Frequency stability of  
 quartz crystal resonators"  
 Proc. 28<sup>th</sup> - A.F.C.S. - pp. 117 - 180 (1974)
- (22) - J.J. Gagnepain -  
 "Fundamental noise studies of quartz crystal resonators"  
 Proc. 30<sup>th</sup> A.F.C.S. - pp. 84 - 91 (1976)
- (23) - E. Hafner - R.S. Blewer -  
 Proc. I.E.E.E. 56 336 (1968)
- (24) - R. Bechmann - Proc. A.F.C.S. (1953)  
 and W. Ianouchevsky - Proc. 17<sup>th</sup> - A.F.C.S. pp. 233-247 (1963)
- (25) - A.G. Smagin -  
 Pribory i Tekhnika Ekspeimenta N°6 - pp. 143 - 145  
 (Nov. Dec. 1974)
- (26) - French Patents n° 76 01 035 (2.338.607) n° 76 16 289-  
 "Résonateur à quartz à électrodes non adhérentes au cristal"
- (27) - French Patent n° 78 02 261 -  
 "Résonateur piézoélectrique à cristal auto-suspendu"
- (28) - J.R. Vig - C.F. Cook - K. Schwidtal - J.W. Lebus - E. Hafner -  
 "Surface studies for quartz resonators"  
 Proc. A.F.C.S. - pp. 96 - 108 (1974)
- (29) - J.R. Vig - J.W. Lebus -  
 "Further results on UV cleaning and Ni electrobonding"  
 Proc. A.F.C.S. - pp. 220 - 229 (1975)
- (30) - B. Dulmet -  
 "Etude théorique et expérimentale de quelques paramètres régis-  
 sant le fonctionnement des résonateurs à quartz"  
 Thesis n°87 - Besançon 1978
- (31) - Measurements performed in O.N.E.R.A. - 92230 Chatillon - France
- (32) - French Patent n° 78 28 728 -  
 "Bi-résonateur piézoélectrique"

- (33) - French Patent n°78 02 261 -  
"Résonateur piézoélectrique à cristal autosuspendu"
- (34) - French Patent n°77 17 309 -  
"Résonateur piézoélectrique à suspension amélioré"
- (35) - M. Valdois - J. Besson and JJ Gagnepain -  
"Influence of environment conditions on a quartz resonator"  
Proc. 28<sup>th</sup> A.F.C.S. - pp. 19 - 32 (1974)
- (36) - D. Janiaud -  
"Modélisation de l'influence d'une accélération sur la fréquence des résonateurs à quartz" - Besançon 1978.
- (37) - P C Y Lee and Kuang-Ming Wu -  
"The influence of support configuration on the acceleration sensitivity of quartz resonator plates"  
Proc. 31<sup>st</sup> - A.F.C.S. - pp. 29 - 34 (1977)  
and "Effects of acceleration on the resonance frequencies of crystal plates"  
Proc. 30<sup>th</sup> - A.F.C.S. - pp. 1 - 7 (1976)
- (38) - A. Ballato - T. Lukaszek - E.P. Eer Nisse -  
"The force frequency effect in Doubly Rotated quartz Resonators"  
Proc. 31<sup>st</sup> - A.F.C.S. - pp. 8 - 16.
- (39) - H.F. Tiersten and B.K. Sinha -  
"Temperature induced Frequency changes in Electroded AT-cut Quartz Thickness shear Resonators"  
Proc. 31<sup>st</sup> - A.F.C.S. - pp. 23 - 28.
- (40) - A. Ballato - J.R. Vig -  
"Static and dynamic Frequency-Temperature behavior of singly and doubly rotated, oven controlled quartz resonators"  
Proc. 32<sup>nd</sup> - A.F.C.S. - pp.180 - 188.
- (41) - Measurements of environmental influence on B.V.A. crystals -  
Work currently performed on a cooperation basis by O.N.E.R.A. and E.N.S.C.M.B. France.
- (42) - R.J. Besson - B.M. Dulmet and D.P. Gillet -  
"Analysis of the influence of some parameters in quartz bulk resonators"  
Proc. Ultrasonics Symposium (1978).

- (43) - E. Hafner - W.J. Riley -  
 "Implementation of bridge measurement techniques for quartz  
 crystal parameters"  
 Proc. 30<sup>th</sup> - A.F.C.S. - pp. 92 - 102 (1976)
- (44) - A. Ballato - R. Tilton -  
 "Ovenless Activity Dip Tester"  
 Proc. 31<sup>st</sup> - A.F.C.S. - pp. 102-107 (1977)
- (45) - J.R. Vig - J.W. Lebus - R.L. Filler -  
 "Chemically polished quartz"  
 Proc. 31<sup>st</sup> - A.F.C.S. - pp. 131 - 143 (1977)
- (46) - M. Berté -  
 "Acoustic bulk wave resonators and filters operating in the  
 fundamental mode at frequencies greater than 100 MHz"  
 Proc. 31<sup>st</sup> - A.F.C.S. - pp. 122 - 125 (1977)
- (47) - P.D. Wilcox - G.S. Snow - E. Hafner - J.R. Vig -  
 "A new ceramic flat pack for quartz resonators"  
 Proc. 29<sup>th</sup> - A.F.C.S. - pp. 202 - 210 (1975)
- (48) - R.N. Castellano - J.L. Hokanson -  
 "A survey of Ion beam milling techniques for piezoelectric  
 device fabrication"  
 Proc. 29<sup>th</sup> - A.F.C.S. - pp. 128 - 134 (1975)
- (49) - M.L. White -  
 "Clean surface technology"  
 Proc. 27<sup>th</sup> - A.F.C.S. - pp. 89 - 94 (1973)
- (50) - R.L. Filler - J.M. Frank - R.D. Peters - J.R. Vig -  
 "Polyimide bonded resonators"  
 Proc. 32<sup>nd</sup> - A.F.C.S. - pp. 290 - 298 (1978)
- (51) - C.K. Hruska -  
 "The electroelastic tensor and other second order phenomena in  
 quasi linear interpretation of the polarizing effect with  
 thickness vibration of quartz plates"  
 Proc. 31<sup>st</sup> - A.F.C.S. - pp. 159 - 170 (1977)
- (52) - F. Euler - P. Ligor - A. Kahan - P. Pellegrini - T. Flanagan -  
 T. Wrobel -  
 "Steady state radiation effects in precision quartz resonators"  
 Proc. 32<sup>nd</sup> - A.F.C.S. (1978)
- (53) - F.L. Walls - S.R. Stein -  
 "Accurate measurements of spectral density of phase noise in

devices"  
Proc. 31<sup>st</sup> - A.F.C.S. - pp. 335 - 343 - (1977)

- (54) - D.W. Allan -  
"Measurement of frequency and frequency stability of precision oscillators "  
N.B.S Technical Note 669 (1975)
- (55) - J. Rutman -  
"Characterization of phase and frequency instabilities in precision frequency sources"  
Proc. I.E.E.E. - Vol. 66 N°9 - pp. 1048 - 1075 (Sept. 1978)
- (56) - R.S. Stein - F.L. Walls -  
"Composite oscillator systems for meeting user needs for time and frequency" somewhere i these proceedings.

## QUESTIONS AND ANSWERS

DR. HELMUT HELLWIG, National Bureau of Standards

I would like to make a comment before I ask for questions. As far as I can remember, the original suggestion at NBS to build a measurement system to measure passive crystal resonators is due to Donald Halford. Are there any questions?

MR. JOHN R. VIG, Army Electronics R&D

You mentioned that for your dual BVA design, the acceleration sensitivity was a factor of 20 times better. Better than what? You mentioned several sensitivities before that, and I wasn't sure which.

DR. BESSON:

Okay. Better than the usual for an AT cut, which is  $8 \times 10^{-11}$ .

MR. VIG:

Have you tried the dual for the SC?

DR. BESSON:

Not yet. It is done but not tested.

DR. CARL HOSHKA, York University

How long does it take to produce one of these crystals from a blank?

DR. BESSON:

Well, some steps are faster; some are longer. The step which is critical, and that I did not mention, is a step of addressing the frequency. And with those crystals, you do have a great facility to make the frequency adjustment because you have only to change the gap.

And then you have only to evaluate, let's say, condensers with different gaps, and it comes out that you just have to change gaps, and that is it. So I would talk about prices, okay? I think prices so far as we see in the investigation lab, which is not industry, are 1.2 to 1.7 for a usual crystal.

DR. HOSHKA:

And time-wise? If we were to concentrate just on the mechanical part, the crude part, cutting?

DR. BESSON:

It is not that different, finally.

DR. MICHEL TETU, Laval University:

In the dual crystal resonator that you have, you showed that the central electrode was coated on the center quartz. Does this mean that it will affect the long-term stability of the oscillator--drift and things like this?

DR. BESSON:

I don't understand. The central piece of quartz is not vibrating.

DR. TETU:

No, but you have the electrode on it, right?

DR. BESSON:

Yes, and it doesn't make any difference. The two BVA designs, basically, have no electrode on the vibrating crystal. That (the coated central piece of quartz) is simply a common electrode, so-- No, basically you have the same design.

MR. VIG:

Have any manufacturers expressed an interest in making BVA crystals? And if so, do you expect them to become commercially available in the future?

DR. BESSON:

Yes, I think the crystals will be made (manufactured) but I can't say when.

DR. HELLWIG:

I think Dr. Besson has a whole series of patents, and I think it is reasonably public knowledge that some companies are interested in rights, and have secured rights to those patents.

DR. ALFRED KAHAN, Rome Air Development Center

It seems that the ideal resonator would be a double-rotated SC cut, or some type cut, electrodeless, operating below liquid helium at lambda temperatures. Have you put those three items together?

DR. BESSON:

We are currently doing it at NDS, but we don't have any results yet.