

5/4
N79-24745

RUBIDIUM FREQUENCY STANDARD TEST
PROGRAM FOR NAVSTAR GPS

Frank K. Koide and Darrell J. Dederich
Electronic Systems Group
Rockwell International, Anaheim, California

ABSTRACT

Space-qualified Rubidium Frequency Standards (RFS) are being developed for the NAVSTAR Global Positioning System (GPS) program by Rockwell International Electronic Systems Group.

This paper will present the test data of the RFS Program in the Production Phase and computer automation as an essential element in the evaluation of the RFS performance in a simulated spacecraft environment.

Typical production test data will be discussed for stabilities from 1 to 100,000 seconds averaging time and simulated time error accumulation test. Also, design considerations in developing the RFS test systems for the acceptance test in production will be discussed in the paper. Finally, as part of a life-cycle test in vacuum, stability data to 1,000,000 seconds averaging time will be presented.

INTRODUCTION

The Electronic Systems Group (ESG) of Rockwell International has been involved in the engineering development and production of the Rubidium Frequency Standard for the GPS Phase I effort since 1974. In Phase I of the program, ESG will produce a total of 29 RFS; one prototype, three engineering models, and 25 production units. Currently, all but four units have been delivered to our sister Group, the Space Systems Group who is the Prime Contractor for the satellite NAVSTAR-GPS Program.

The first series of four GPS satellites are in orbit, with each carrying three redundant RFS. Three of the satellites have been declared operational, and initial test results proved that the user equipment is capable of navigation accuracies better than three meters in three dimensions. When the fourth NAVSTAR satellite is declared operational, the prime objective of validating the Global Positioning System, will be accomplished.

The RFS test cycle (Figure 4) covers two major phases, the pre-production and the acceptance level testing. The pre-production testing covers the board and system assembly, where tests are made of the components, absolute frequency, temperature compensation, and repairs, if required. The acceptance-level testing includes the environmental and certification tests. All of the certification tests and part of the pre-production and environmental tests are performed on three test systems located within the Metrology Laboratory of ESG.

Testing completed to date indicates that the RFS meets or exceeds the GPS specifications for Phase I, and is a potential candidate for the forthcoming Phase II/III Programs.

TEST SYSTEM DESCRIPTION

The three automated test systems (Figure 1) are supported by a DEC PDP 11/35 computer which utilizes a timeshare operating system. A valuable feature of this operating system utilized in this application, is the ability to access data being stored by executing an independent data analysis program at another remote terminal, without interrupting the data collection process.

The frequency stability certification test (Figure 4) is performed using test stations one and three (Figures 2 and 3). This test requires that data be collected for nine days without interruption. Microcomputers are included in these test stations to provide redundant data collection and storage if the main computer should fail. At the end of the test, these data would then be transferred to the PDP 11/35 for analysis. Failsafe devices are incorporated into all test stations to protect against RFS supply over-voltage and current, and over and under base-plate temperatures.

The RFS supply current and telemetry-monitored testpoint levels are recorded throughout the test cycle. The RFS frequency is measured using a "Time Mark System. [2] This system, developed by ESG Metrology, is similar in principle to the NBS chronograph. The heterodyned beat period is measured without dead time (the loss of time required to rearm the counter). In this system, the beat-frequency zero crossings load the value of a free running counter into an output buffer. This system was implemented by simple modification of an electronic counter.

Figure 5 shows the RFS mounted in the vacuum chamber which simulates the spacecraft pressure. Cooling is provided through the RFS baseplate to the mounting block which simulates the spacecraft mounting. Coolant from a temperature-stabilized bath is circulated through a maze within the block.

The RFS is fundamentally an Efratom Rubidium Frequency Standard repackaged with extensive modification to meet space environmental, reliability and space-craft interface requirements. The RFS is 8 in. x 5 in. x 4.5 in. in size, weights 8-1/2 lb and consumes less than 30 watts of power. The nominal output frequency is 10.23 MHz.

RFS PERFORMANCE

The data collected to obtain the two-sample Allan Variance [3,4] computer printout of Section 1, Figure 6, is for a 1-second fundamental beat period. Adjacent data pairs are averaged to obtain the 2-second Allan Variance, and so on for the 4- and 8-second results. The second section fundamental beat is 10 seconds. The third and fourth section results are calculated from stored data that is the average of 10 (100-seconds) and 80 (800 seconds) 10-second beat periods. This method is a reasonable alternative to storing large amounts of data, and still retaining acceptable confidence limits. The calculated drift per day is based on the last 5 days of testing. The Allan Variance results presented in Figure 6 reflect the removal of a first-order curve (drift).

Figure 7 is a graphical representation of the 800-second data used to calculate the Allan Variance of Figure 6. The graphs are the average of 10, 20, and 50, 800-second data, resulting in 8000, 10,000 and 40,000 seconds per bar. The graph readily demonstrates the exponential warmup characteristic present in the RFS frequency.

Figure 8 is a graphical representation of the printout of Figure 6. The vertical bars at each data point represent the range of confidence limits[3,4]. The inset in the top-right corner is the graph of Figure 7 for the average of 50, 800-second data points. It is apparent, that the warmup characteristic displayed by the inset is the predominant cause of the Allan Variance flattening or turning upward for longer sample times. In Figure 9 where the inset shows essentially flat data, or in Figure 10 where removal of the drift results in a relatively flat plot, the Allan Variance values continue a downward trend.

Figure 12 is a plot of the RFS frequency versus mounting base-plate temperature data. This test simulates possible RFS base-plate temperature excursions during a 12-hour space vehicle orbit. The accumulated time errors and the elapsed times over which they are specified are marked on the plot. The computer printout of Figure 13 shows the time error accumulations and the procurement specifications. Representative profile plots of other units are shown in Figures 14 and 15.

Figure 16 is a plot of the Allan Variance calculated from data collected in a RFS life cycle test conducted by the Space Systems Group of Rockwell International. The calculations reflect removal of the first-order drift characteristic. The test term was 100 days (8600 data of approximately 1000-second averaging time). A graph of the data revealed two distinct drift characteristics separated near the midpoint of the test. Both are very nearly linear. It seems likely that this change in the drift slope was caused by an

external influence on the RFS. The plot using the . symbol is the Allan Variance calculated from data points 1-8600, and the plot using the x symbol is calculated from data points 4300 - 8600.

These data indicate that the RFS, after adequate stabilization, is capable of meeting the GPS Phase II/III specification as shown in the figure.

ACKNOWLEDGEMENTS

The authors wish to express their sincere appreciation to Laurie Baker of Metrology, who made significant contributions in the development of the vacuum test systems and the temperature-control system for the Rubidium Frequency Standards.

REFERENCES

1. F. K. Koide and E. M. Hicks, "Atomic Clock Test Program for NAVSTAR," Fifth Cal-Poly Measurement Science Conference, December 1975.
2. E. M. Hicks, "An Innovative Method for Measuring Frequency Stability without Deadtime," Sixth Cal-Poly Measurement Science Conference, December 1976.
3. J. A. Barnes et al, "Characterization of Frequency Stability," NBS Technical Note 394, Issued October 1970; IEEE trans. on Instr. & Meas., IM-20, 1971.
4. P. Lesage and C. Audoin, "Characterization of Frequency Stability," IEEE Transactions on Instr. & Meas., IM-22, June 1975.

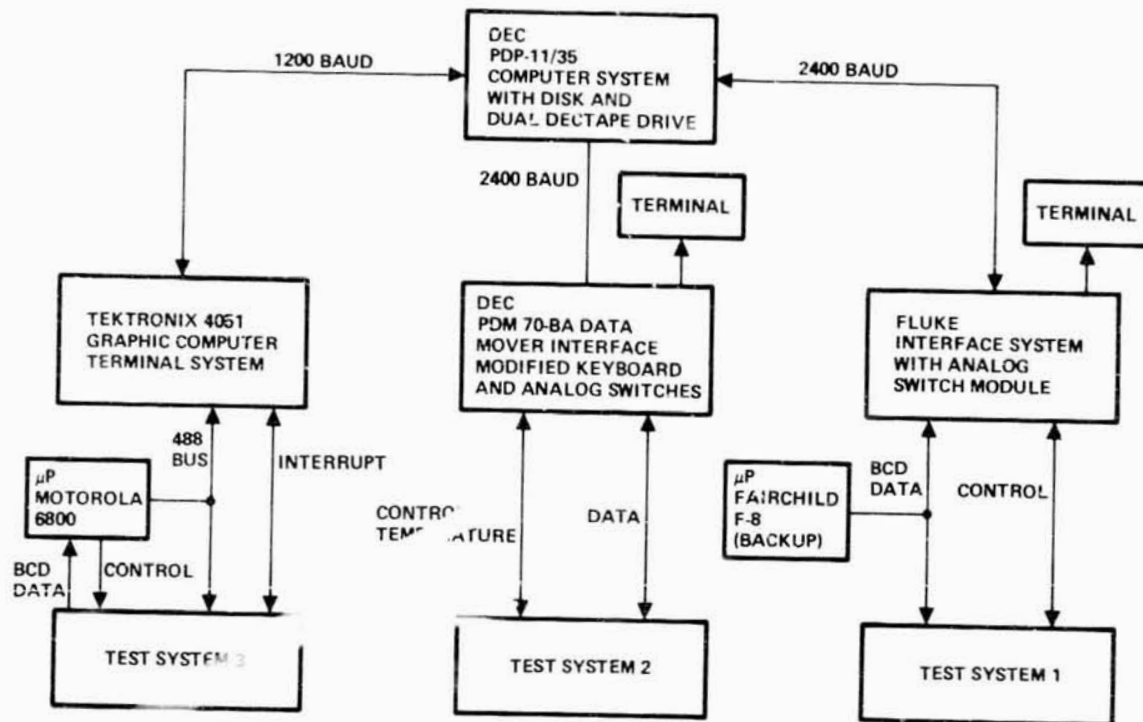

Fig. 1—Overall Automated Test Systems

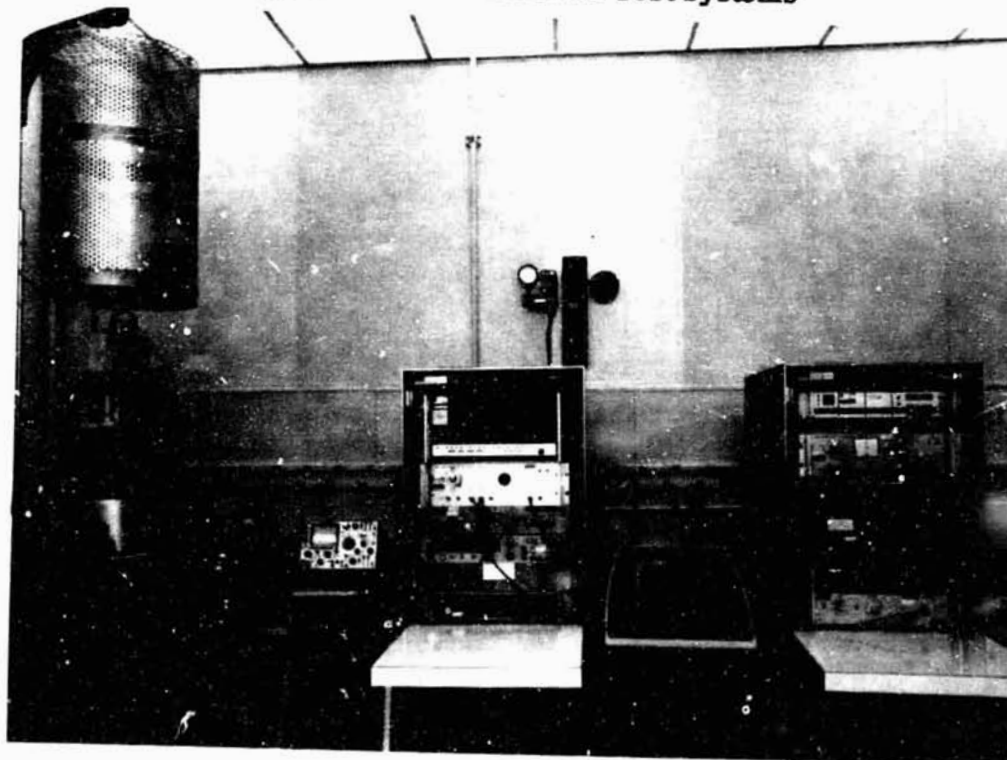

Fig. 2—Test Systems 1

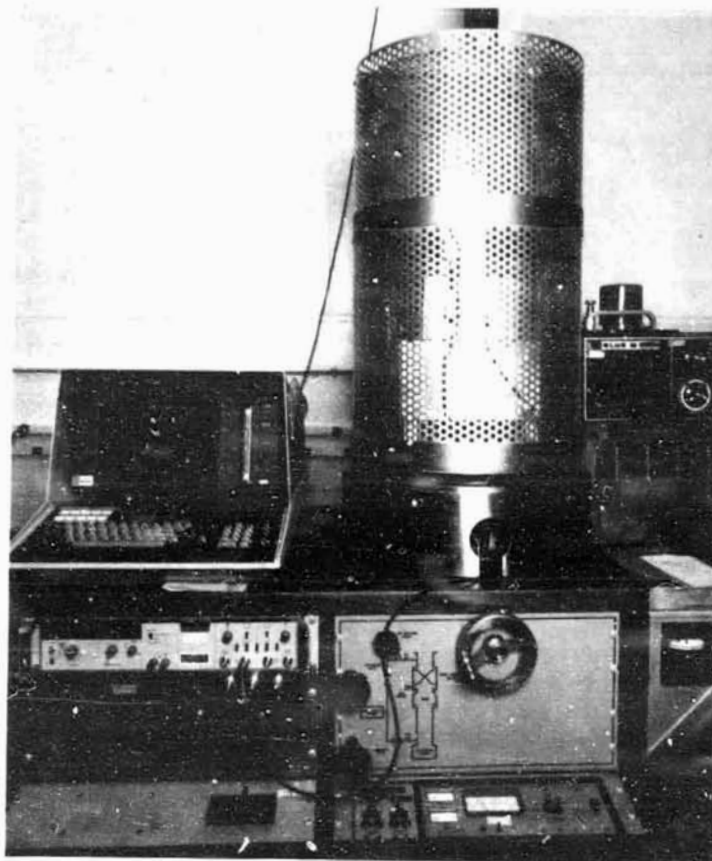

Fig. 3—Test System 3

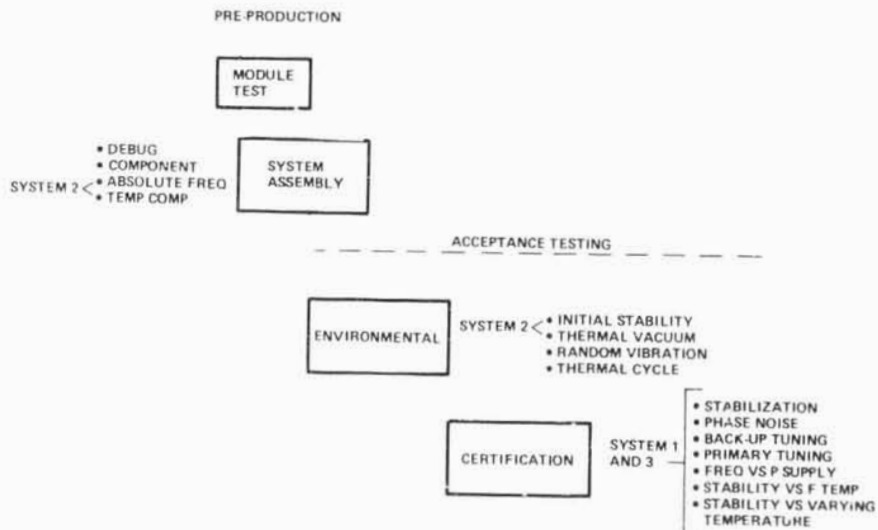

Fig. 4—Testing Cycle

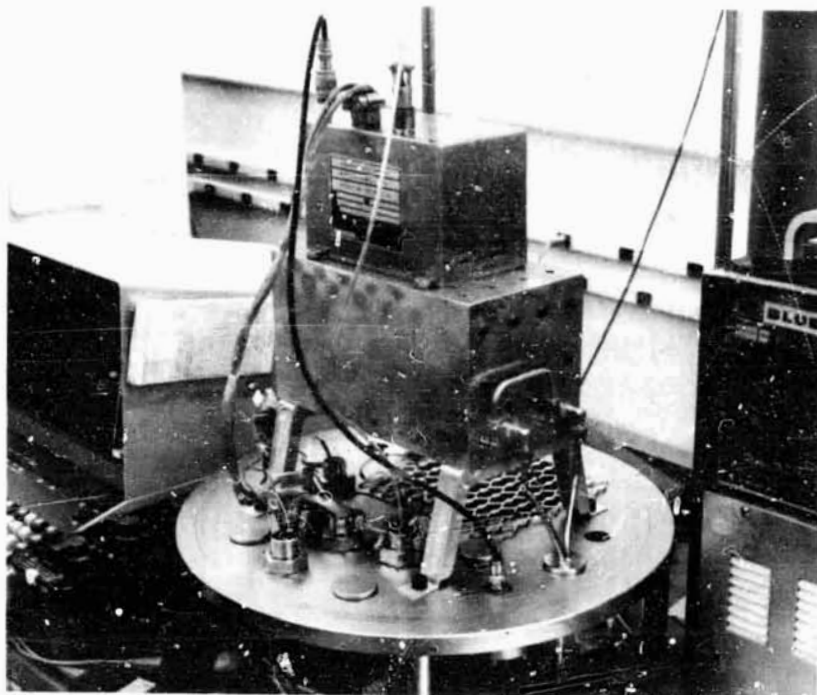

Fig. 5—Rubidium Frequency Standard

RUN
NEAL 15 37 31-OCT-78
SERIAL NO OF RFS? 006
CURRENT COUNT ? 1200

LONG TERM STABILITY TEST 07-OCT-77 00 33
TEMPERATURE HELD BETWEEN 24.7 AND 25 DEGREES CELSIUS

ALLAN VARIANCE CALCULATIONS

ORIGINAL PAGE IS
OF POOR QUALITY

F	SAMPLES	TAU	SIGMA	CONF LOW LIM	CONF UP LIM
1	100	1.00	6.29E-12	5.74E-12	7.03E-12
2	50	2.00	6.79E-12	5.48E-12	7.30E-12
4	25	4.01	5.92E-12	4.71E-12	7.13E-12
8	12	8.01	5.00E-12	3.49E-12	6.50E-12

1	100	10.37	3.25E-12	2.97E-12	3.53E-12
2	50	20.74	2.97E-12	2.60E-12	3.34E-12
4	25	41.48	2.14E-12	1.76E-12	2.52E-12
8	12	82.96	0.29E-11	6.12E-13	1.05E-12

1	100	103.68	1.25E-12	1.14E-12	1.35E-12
2	50	207.35	9.60E-13	0.48E-12	1.09E-12
4	25	414.70	6.16E-13	5.06E-13	7.25E-13
8	12	829.40	5.40E-13	3.99E-13	6.82E-13

1	900	828.26	4.42E-13	4.30E-13	4.55E-13
2	450	1656.51	3.06E-13	2.93E-13	3.10E-13
4	225	3313.02	2.14E-13	2.01E-13	2.26E-13
8	112	6626.05	1.49E-13	1.37E-13	1.62E-13
16	56	13252.10	1.50E-13	1.26E-13	1.74E-13
32	28	26504.19	1.60E-13	1.23E-13	1.97E-13
64	14	53008.38	2.24E-13	9.32E-14	3.55E-13
128	7	106016.77	3.67E-13	0.26E-14	6.52E-13
256	3	212033.54	5.08E-13	0.00E-00	1.19E-12

REMOVES DRIFT

DRIFT/DRV= 377746E-12

READY

Fig. 6—Computer Printout of Allan Variance Calculation

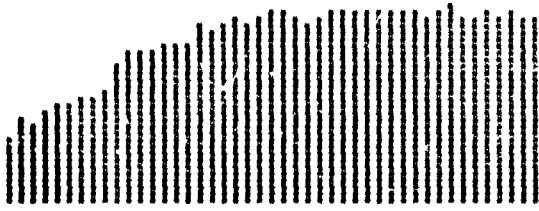

DISPLAY IS THE AVERAGE OF
20 DATA POINTS (16,000 SEC/
DATA) RESOLUTION = 2 PARTS
IN 10 TO 13TH (900 DATA)

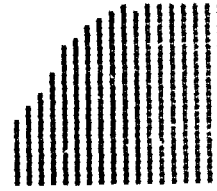

DISPLAY IS THE AVERAGE OF
50 DATA POINTS 40,000 SEC/
DATA RESOLUTION = 2 PARTS
IN 10 TO 13TH (900 DATA)

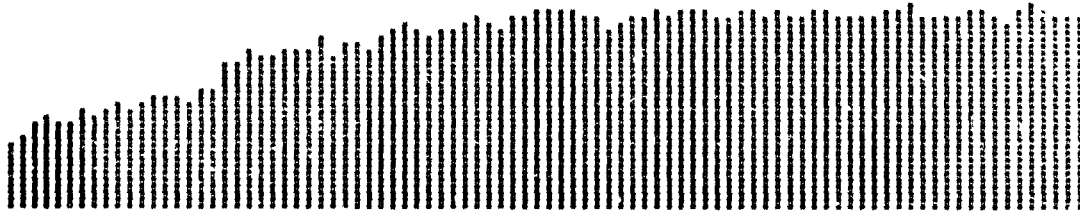

DISPLAY IS THE AVERAGE OF
10 DATA POINTS (8,000 SEC/
DATA) RESOLUTION = 2 PARTS
IN 10 TO 13TH (900 DATA)

Fig. 7—Graphical Plots (SN 6)

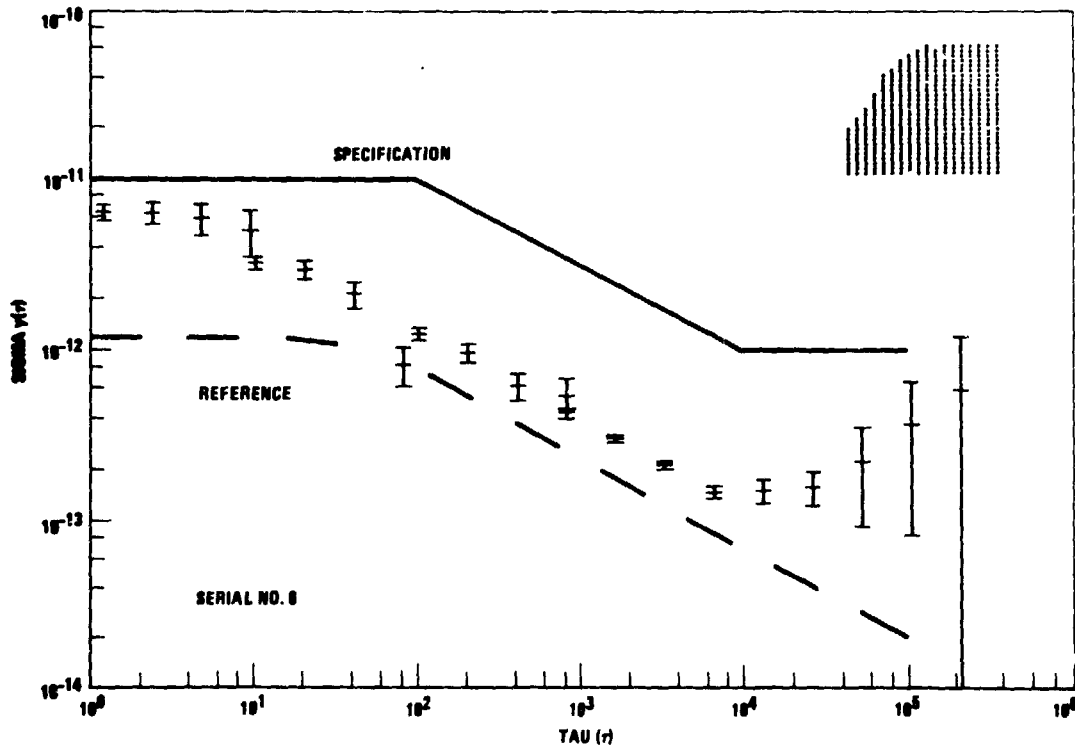

Fig. 8—Computer Printout of Allan Variance Plot

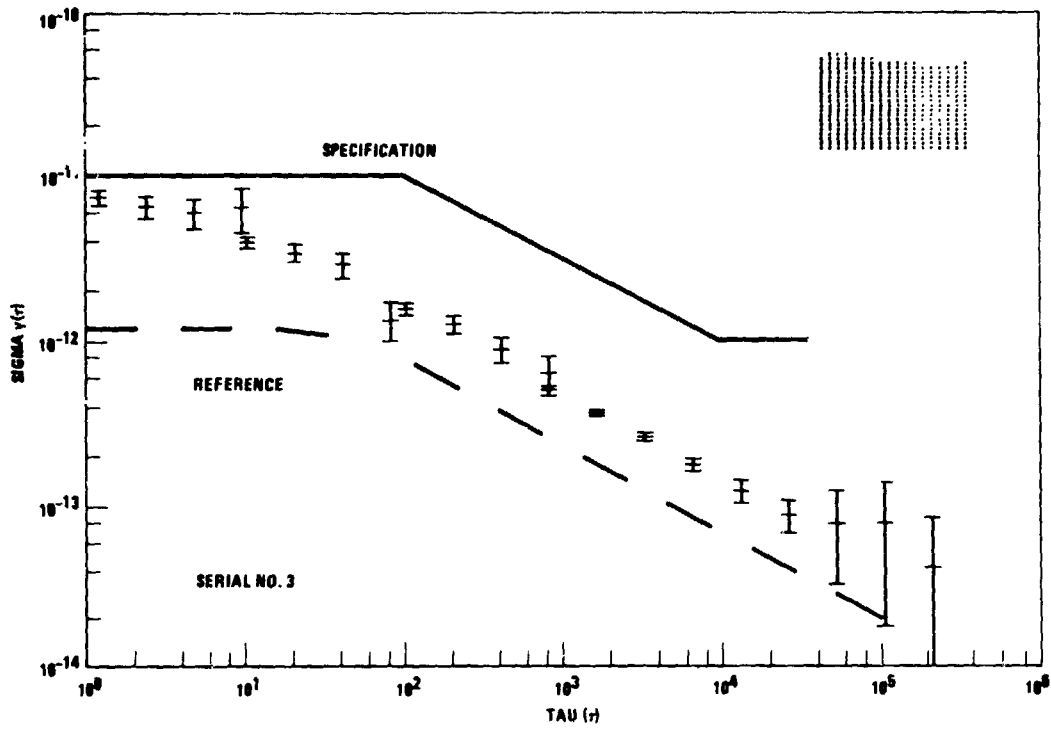

Fig. 9—Computer Printout of Allan Variance Plot

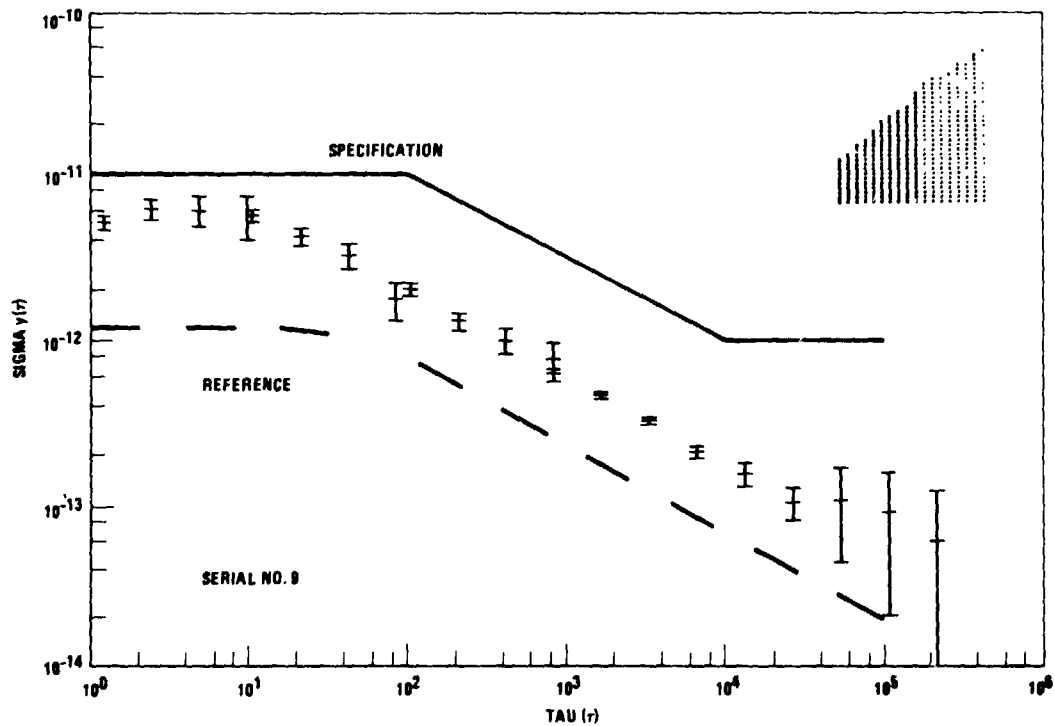

Fig. 10—Computer Printout of Allan Variance Plot

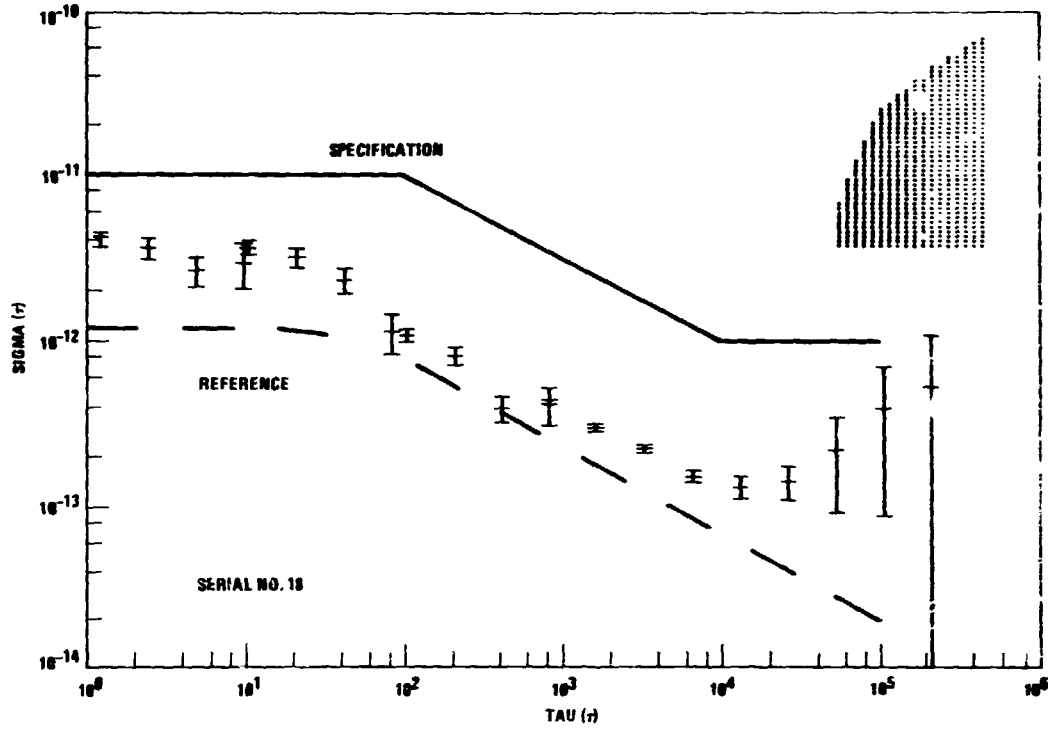

Fig. 11—Computer Printout of Variance Plot

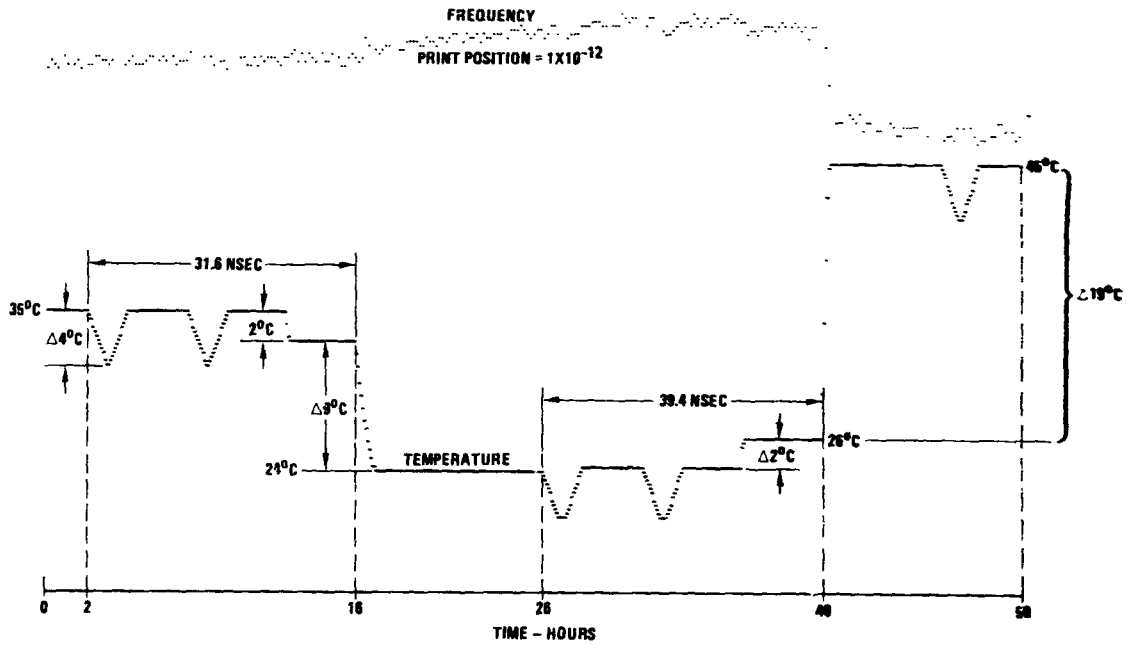

Fig. 12—Computer Plot

RUN 10 17 06-NOV-78
 F SERIAL NO OF RFS? 00C

TEMP. STABILITY TEST	29-JUN-78	14 16	L-LIMIT	U-LIMIT	ELSPD	DEG-C	N-SECS	L-LIMIT	U-LIMIT
ELSPD	DEG-C	N-SECS	PHRSE	PHRSE	TIME	TEMP	PHRSE	PHRSE	PHRSE
TIME	TEMP	PHRSE	-65 00	65 00			-75 00	75 00	
0 00	25 1	0 00			25 00	23 7	0 00		
0 45	25 1	0 21			25 43	23 6	0 40		
0 55	25 0	0 51			25 56	22 4	0 51		
1 20	25 0	1 03			26 30	20 7	1 04		
1 33	25 1	2 15			26 33	20 0	-0 17		
2 16	25 4	2 41			27 16	21 9	-2 09		
2 59	25 1	2 58			27 59	23 6	-1 08		
3 11	25 1	2 58			28 01	23 7	-0 92		
3 46	25 1	3 14			28 46	23 7	0 68		
3 59	25 1	3 14			28 59	23 7	2 21		
4 32	25 1	4 46			29 32	23 7	3 74		
4 46	25 1	5 29			29 75	23 7	6 54		
5 13	25 1	6 03			30 19	23 7	8 01		
5 42	25 4	6 76			30 62	23 7	11 05		
6 05	25 4	8 46			31 05	22 1	13 00		
6 49	25 7	8 57			31 48	20 4	15 33		
6 52	25 1	10 12			32 35	20 3	16 35		
7 13	25 0	10 70			32 70	23 7	14 68		
7 38	25 3	11 34			32 70	23 7	16 04		
8 22	25 1	11 71			33 21	23 7	19 52		
8 43	25 1	13 66			33 64	23 7	21 76		
9 06	25 1	14 53			34 08	23 7	24 37		
9 51	25 1	15 42			34 51	23 7	26 92		
9 55	25 1	17 20			34 94	23 7	29 07		
10 38	25 1	18 07			35 37	23 7	32 05		
10 51	25 1	19 59			35 81	25 6	35 34		
11 24	25 0	21 32			36 24	25 7	34 07		
11 49	25 0	23 58			36 67	25 8	34 24		
12 11	25 0	25 09			37 10	25 8	34 98		
12 34	25 0	26 00			37 53	25 8	35 97		
12 57	25 0	26 31			37 97	25 8	37 47		
13 41	25 0	29 28			38 40	25 8	38 21		
13 58	25 0	30 57			38 83	25 8	39 56		
14 17	25 1	31 11			39 00	25 8	39 66		
14 33	25 0	31 22			39 09	25 8	39 39		
14 54	25 0	31 31							
15 01	25 0	31 37							
15 01	25 0	31 44							

a

b

Fig. 13—Computer Printout of Frequency vs Temperature Profile Test

ORIGINAL PAGE IS
 OF POOR QUALITY

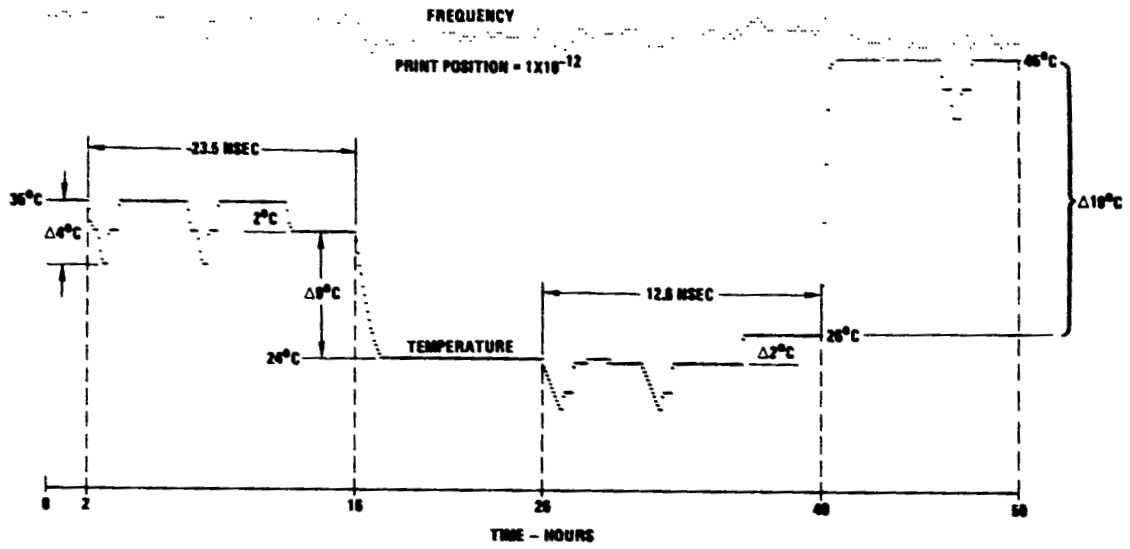

Fig. 14—Computer Plot

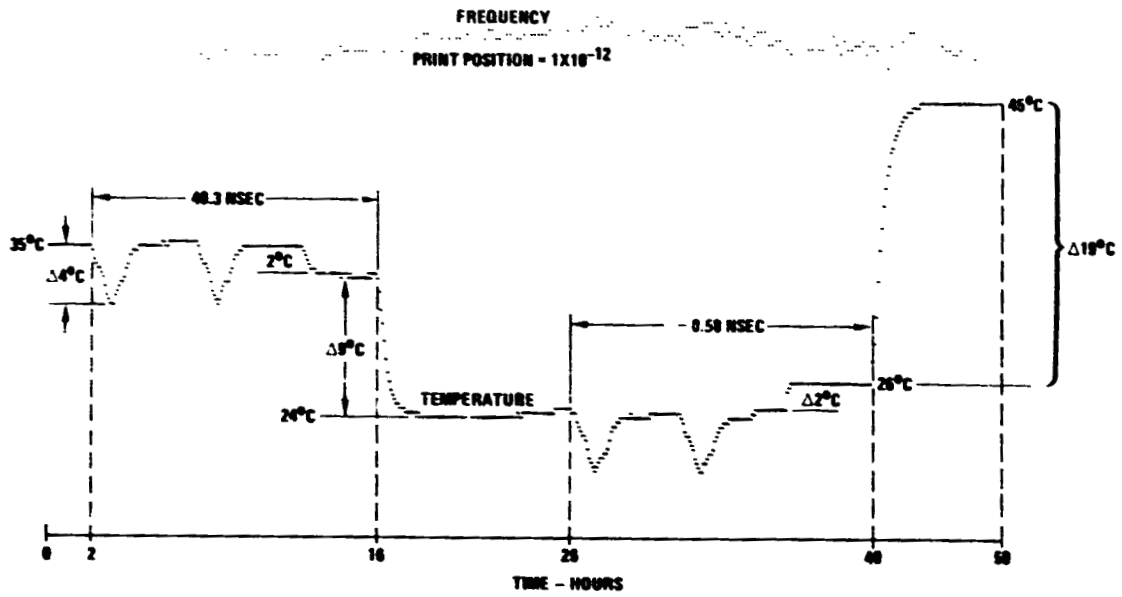

Fig. 15—Computer Plot

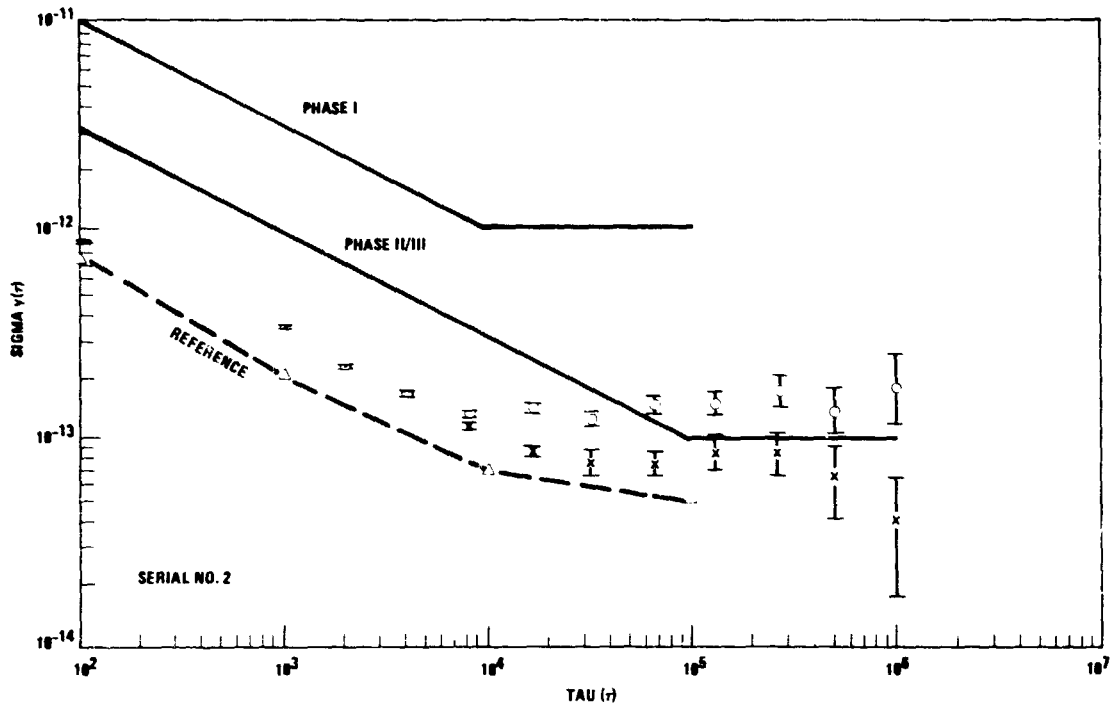

Fig. 16—Allan Variance Plot/Life Cycle Test

QUESTIONS AND ANSWERS

MR. HUGO FRAUHOFF, Efratom California:

I just want to make sure that everyone knows that Efratom is teamed with Rockwell.

MR. KOIDE:

I think I forgot to mention that.

MR. ANDREW CHI, NASA Goddard Space Flight Center:

In your presentation of the frequency plot versus temperature or temperature versus time, in one curve there was a sudden jump in frequency. Could you explain why there was a large jump?

MR. KOIDE:

Yes, we don't really have an answer to that. There are many variables that cause that, and we are still looking into it. So I don't want to go into that.