

TRANSIT SATELLITE SYSTEM TIMING CAPABILITIES

Theodore D. Finsod
Navy Astronautics Group
Point Mugu, California

ABSTRACT

Within the last year a series of events have occurred with respect to the operational Navy Navigation Satellite System (NNSS), also known commercially as TRANSIT, which may have direct benefits for the Precise Time and Time Interval (PTTI) community.

In September of 1977 the Director, Strategic Systems Projects granted permission for the Navy Astronautics Group (NAVASTROGRU), in cooperation with the U. S. Naval Observatory (NAVOBSY), to define changes in equipment and operational procedures which could improve TRANSIT satellite time accuracy with respect to UTC (NAVOBSY Master Clock).

For the first time in the 14-year service history of the TRANSIT System, requirements specific to timing accuracy will soon be implemented.

Recent development of a TRANSIT Model T-200 Satellite Timing Receiver by Satellite Navigation Systems, Inc. expedites TRANSIT time transfer capabilities as well as providing NAVASTROGRU an independent measurement of satellite time.

A new generation of superior satellites (NOVA) will be launched starting in early 1980 to augment the existing operational TRANSIT constellation.

This paper reviews the TRANSIT Satellite System in terms of its current time transfer capabilities. Potential improvements using current operational satellites are discussed in terms of changes in equipment and operational procedures which can be made with minimal effort or expenditure and without degradation to the NAVASTROGRU primary (navigational) mission.

INTRODUCTION

The Navy Navigation Satellite System (NNSS) is a fully operational navigation system that enables the Navy Fleet or commercial users to accurately obtain their position anywhere on Earth, day or night, and in any weather. The NNSS, commonly known as TRANSIT, became fully operational in January 1964 and was released for uncontrolled public use by a Presidential directive in July 1967. TRANSIT is operated by the Navy Astronautics Group (NAVASTROGRU), located at Point Mugu, California.

The Applied Physics Laboratory of the Johns Hopkins University (APL/JHU) has played the central role in the technical development of the TRANSIT System. The original idea was conceived there, most of the actual development was performed there, and APL continues to provide technical support in maintaining and improving the system. Figure 1 illustrates the position of NAVASTROGRU in the Navy chain of command.

Today TRANSIT consists of a constellation of five operational satellites in fixed circular polar orbits at an altitude of approximately 1100 kilometers. The characteristics of the current operational TRANSIT satellites as well as their (less than optimal) longitudinal coverage as of 1 April 1978, are summarized in figure 2. All points on the surface of the Earth periodically pass under each orbital path with a nominal time between passes of 90 minutes.

The TRANSIT System requires accurate time to accomplish its navigational mission. For this reason the satellites transmit a precisely timed fiducial time mark (FTM) every two minutes. The timekeeping ability of the operational NNSS is superior to that required for the navigational mission, but is perhaps only marginal in terms of modern Precise Time and Time Interval (PTTI) standards. Within the last year, however, a series of events have occurred with respect to the operational TRANSIT System which may have direct benefits for the PTTI community.

1. In September 1977 the Director, Strategic Systems Projects (DIRSSP) granted permission for NAVASTROGRU, in cooperation with the U. S. Naval Observatory (NAVOBSY), to define changes in equipment and operational procedures which could improve TRANSIT satellite time accuracy with respect to UTC (NAVOBSY Master Clock).

2. The recent development and availability of a TRANSIT T-200 Satellite Timing Receiver by Satellite Navigation Systems, Inc. expedites TRANSIT time transfer capabilities as well as providing NAVASTROGRU an independent measurement of satellite time.

3. In November 1977 the DIRSSP approved the NAVASTROGRU recommendation to install and evaluate a TRANSIT T-200 Satellite Timing Receiver at its Headquarters Computer Center.

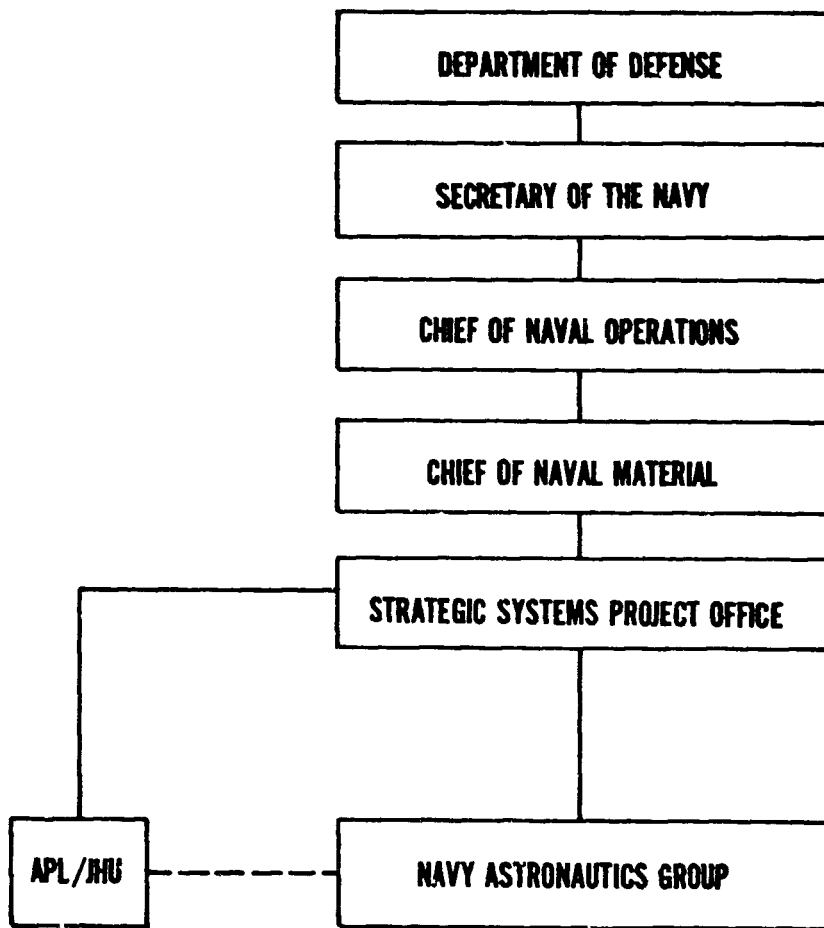

Figure 1. Navy Chain of Command.

CHARACTERISTICS OF OPERATIONAL TRANSIT SATELLITES (APRIL 1978)

SCIENTIFIC NAME	NRES DESIGNATION	LAUNCH DATE	PERIOD (HR)	ALTITUDE PERIGEE (KM)	ECCENTRICITY	INCLINATION (DEG)
1967-34A	30120	14 APR 67	106.65	1043.97	.98347	90.25
1967-48A	30130	18 MAY 67	106.94	1071.40	.99179	90.61
1967-82A	30140	25 SEP 67	106.73	1048.58	.99383	90.24
1970-67A	30180	27 AUG 70	106.86	956.96	.91725	90.13
1973-81A	30200	29 OCT 73	105.95	991.95	.91884	90.11

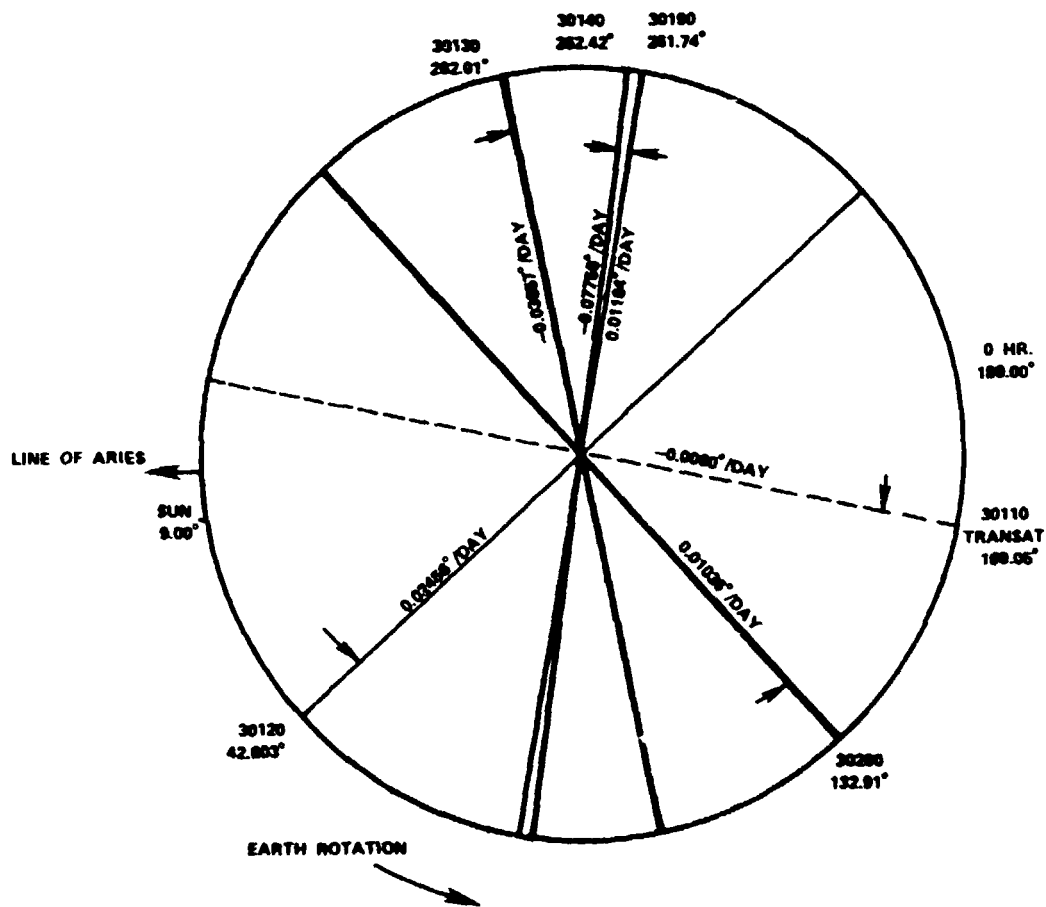

Figure 2. Current Operational TRANSIT Satellite Characteristics.

4. In September 1978 the NAVASTROGRU and NAVOBSY commenced a cooperative test and evaluation program to identify error sources and operational constraints, if any, in transferring TRANSIT time with the TRANSIT T-200 Satellite Timing Receiver.

This report reviews the TRANSIT Satellite System in terms of current time transfer capabilities. Emphasis is placed on time recovery and operational time management. Potential improvements using current operational satellites are discussed in terms of changes in equipment and operational procedures which can be made with minimal effort or expenditure and without degradation to the NAVASTROGRU primary (navigational) mission.

THE TRANSIT SATELLITE SYSTEM

After a brief description of NNSS configuration, we examine in turn the major constituent parts insofar as they determine the time and frequency control of the system.

The NNSS consists of an operational constellation of five TRANSIT satellites and their associated ground support system. The ground support system consists of four tracking stations and a central computer facility. As shown in figure 3, the stations located at Laguna Peak, Point Mugu, California; Rosemount, Minnesota; and Prospect Harbor, Maine, function as both tracking and (message) injection facilities (TRAINFAC's), while the station in Wahiawa, Hawaii, operates only as a tracking facility (TRAFAC). All ground stations have a communication link with the Headquarters Computer Center, located at Point Mugu, California. The operational configuration of the NNSS shown in figure 4 illustrates the salient features which we now summarize.

Each TRANSIT satellite continuously transmits its present ephemeris encoded by phase modulation on two stable carrier frequencies of approximately 150 and 400 MHz. This navigational information is broadcast in two-minute intervals which begin and end at the instant of each even minute. An encoded time marker is part of this broadcast with time uniquely marked at the instant of the even minute. All broadcast frequencies, as well as the satellite clock are based on a highly precise master oscillator.

As pass geometry and operational considerations permit, NAVASTROGRU stations track each satellite to obtain doppler information and the raw timing data. After the satellite has set (typically, 17 minutes elapse from rise to set), the tracking data are transmitted to the Headquarters Computer Center where all measurements from all tracking stations for each satellite are accumulated. At least once a day the data are used in a large computing program to:

1. Determine the contemporary orbit specification for the satellite and predict an ephemeris for the next 16 hours.
2. Compute the necessary corrections to the satellite clock to compensate for the predictable part of the oscillator drift.

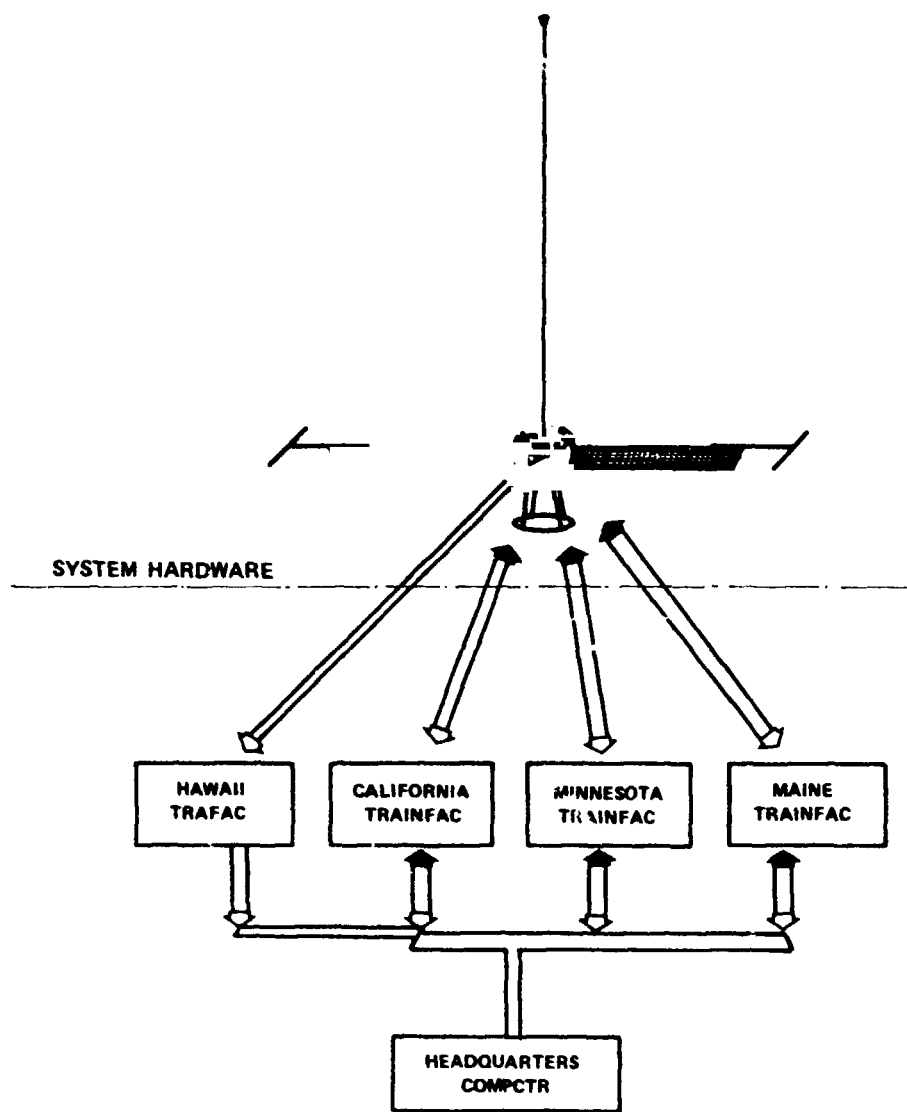

Figure 3. TRANSIT Ground Support System.

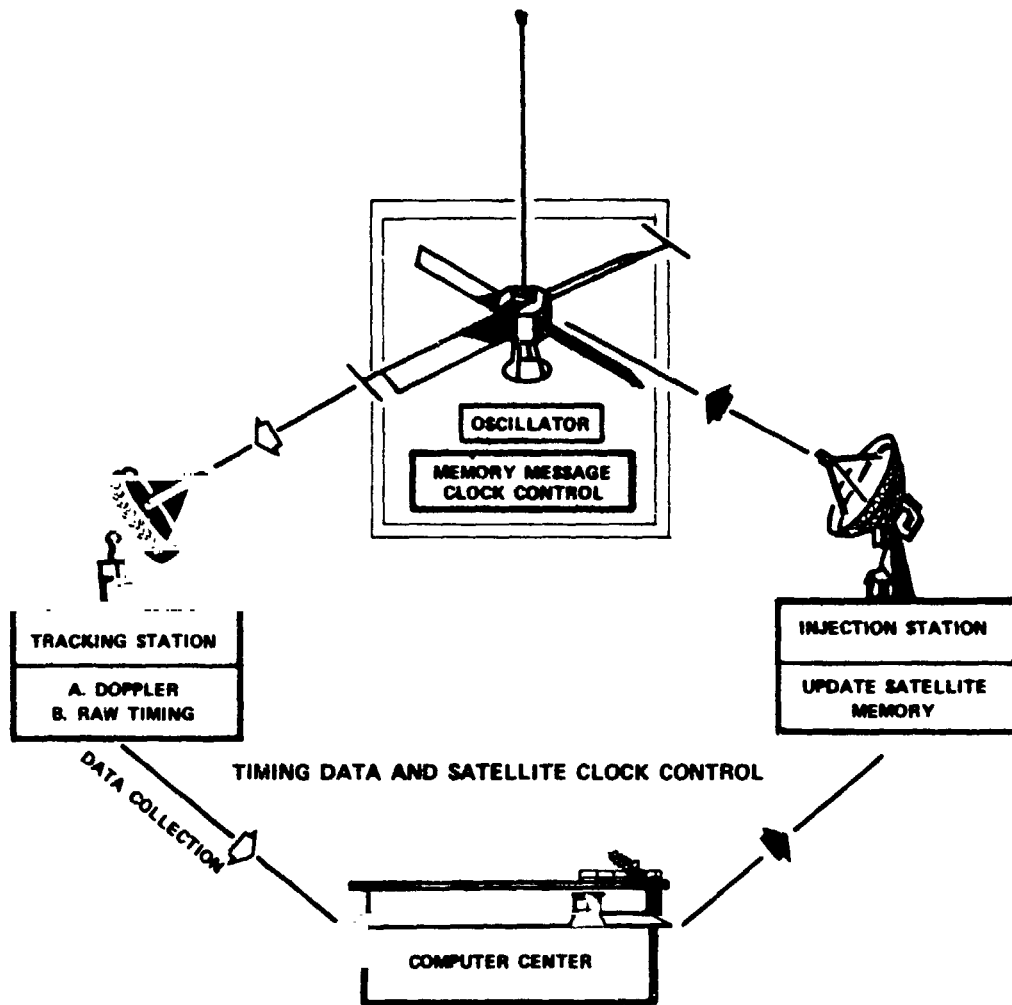

Figure 4. Operational Configuration of the NNSS.

The ephemeris prediction and satellite clock correction information is then transmitted back to all three injection sites. One station performs the injection; however, the mutually-in-view station provides backup in the event of equipment failure. The injection station inserts an updated ephemeris into the satellite memory. Typically, injections into the satellite occur at 12-hour intervals even though the satellite memory has sufficient storage to contain a 16-hour ephemeris. To navigate using a TRANSIT satellite requires a special tracking receiver/computer. This receiver measures the broadcast carrier frequencies at discrete intervals to recover doppler information and simultaneously demodulates them to recover the satellite ephemerides. A small computer is necessary to then calculate the position of the navigator.

TRANSIT SATELLITE CLOCK

The TRANSIT satellite contains an ultrastable 5-MHz oscillator. This oscillator is a temperature-stabilized, crystal-controlled transistor oscillator designed to generate an extremely precise frequency. It is used as the standard frequency source for all satellite operations.

The exact operating frequency of the oscillator will, of course, vary slightly with circuit age and environment. The nominal value or design center is specified as 4,999,600.0 Hz, an offset of 80 parts per million below 5 MHz. The actual value is expected to remain within a tolerance of ± 10.0 Hz (2 parts in 10^6) over the entire operational life of the satellite. Frequency drift rates in flight have been on the order of several parts in 10^{11} per day. Over the time of a single pass (approximately 20 minutes) the drift rate has generally been several parts in 10^{12} .

TRANSIT satellites transmit coherent carrier frequencies of 150 and 400 MHz (offset -80 ppm) by multiplication of the reference oscillator frequency and hence share the same stability. The satellite navigation message will be transmitted on these carriers in the form of a *double-doublet* pattern of phase modulation. The memory read rate is controlled by a clock consisting of a divider chain reducing the master oscillator frequency.

The satellite clock is constructed as an integral part of the memory readout system. Operating from timing provided by the master oscillator, this system is designed to read a complete message periodically every two minutes. A timing mark is included near the beginning of each readout in order to generate a well-defined two-minute interval. Fine control over the timing (or epoch) of the clock is provided so accurate synchronization can be maintained with UTC.

Satellite timing is synonymous with memory readout rate, and timing control is contained within memory content. We therefore describe TRANSIT memory organization before discussing the control of the FTM.

The memory of the TRANSIT satellite consists of 640 thirty-nine-bit words which are divided into a main or a *fixed* memory of 160 words and a variable or an *ephemeral* memory of 480 words. Figure 5 illustrates the TRANSIT satellite memory message format, identification words, and location of the FTM. Although main memory contains 160 thirty-nine-bit words, the satellite will broadcast 6103 bits (i.e., 156 words plus 19 extra bits) evenly spaced over each two-minute interval. (The remaining bits are used for real-time operational commands.) To recover timing and message information from a TRANSIT satellite broadcast a ground receiver must identify the beginning of a message transmission and synchronize with a unique bit pattern to determine the FTM. The first three words of each message broadcast cycle accomplish these goals.

The first word is a BARKER word. The first 33 bits of this word are the barker pattern and are arranged in such a fashion that they never can be repeated in any other part of the message. This allows a ground receiver to identify the starting point of the message. This 33-bit pattern is the same for all TRANSIT satellites. Bits 34 through 37 of this word form a unique satellite identification code while bits 38 and 39 are always zero.

The second word is the synchronization word or SYNC word. The first 14 bits are special-purpose bits. The 15th bit is a zero followed by 23 one's and another zero. It is this final 25-bit pattern which is used in conjunction with the BARKER word by the NAVASTROGRU navigation receivers (AN/BRN-3) to determine the FTM, although by definition the FTM is the first phase transition of the first bit of the third word. This third word is called a BEEP word because the unique bit pattern associated with it produces an audible *beep* of approximately 400 Hz in NAVASTROGRU receiving equipment.

The remaining 153 words of the readout cycle in general contain the information comprising the navigation message to be broadcast. This message (which is periodically transmitted from the ground and stored in the satellite memory) consists primarily of a set of Kepler parameters specifying the current orbit of the satellite. Fine corrections to these *fixed* parameters (which are used by the navigator on the ground to compute a more accurate current satellite position) are provided in a set of eight special words, called ephemeral words. These words taken in pairs contain the corrections needed for a particular two-minute interval.

As indicated in figure 5, each ephemeral word in the set of eight is furnished each readout interval. To keep the set referenced to the indicated past, present, and future two-minute intervals, the set is shifted down six memory locations each readout cycle. The most future entry of the set (word 50) enters from ephemeral memory (word 161) while the oldest entry (word 8) is lost. Since one new word is required each two-minute interval and ephemeral memory can furnish 480 words, the satellite can operate for 16 hours before exhausting its current orbit information. (Injections of updated orbit information are made on a 12-hour basis.)

SATELLITE MESSAGE FORMAT

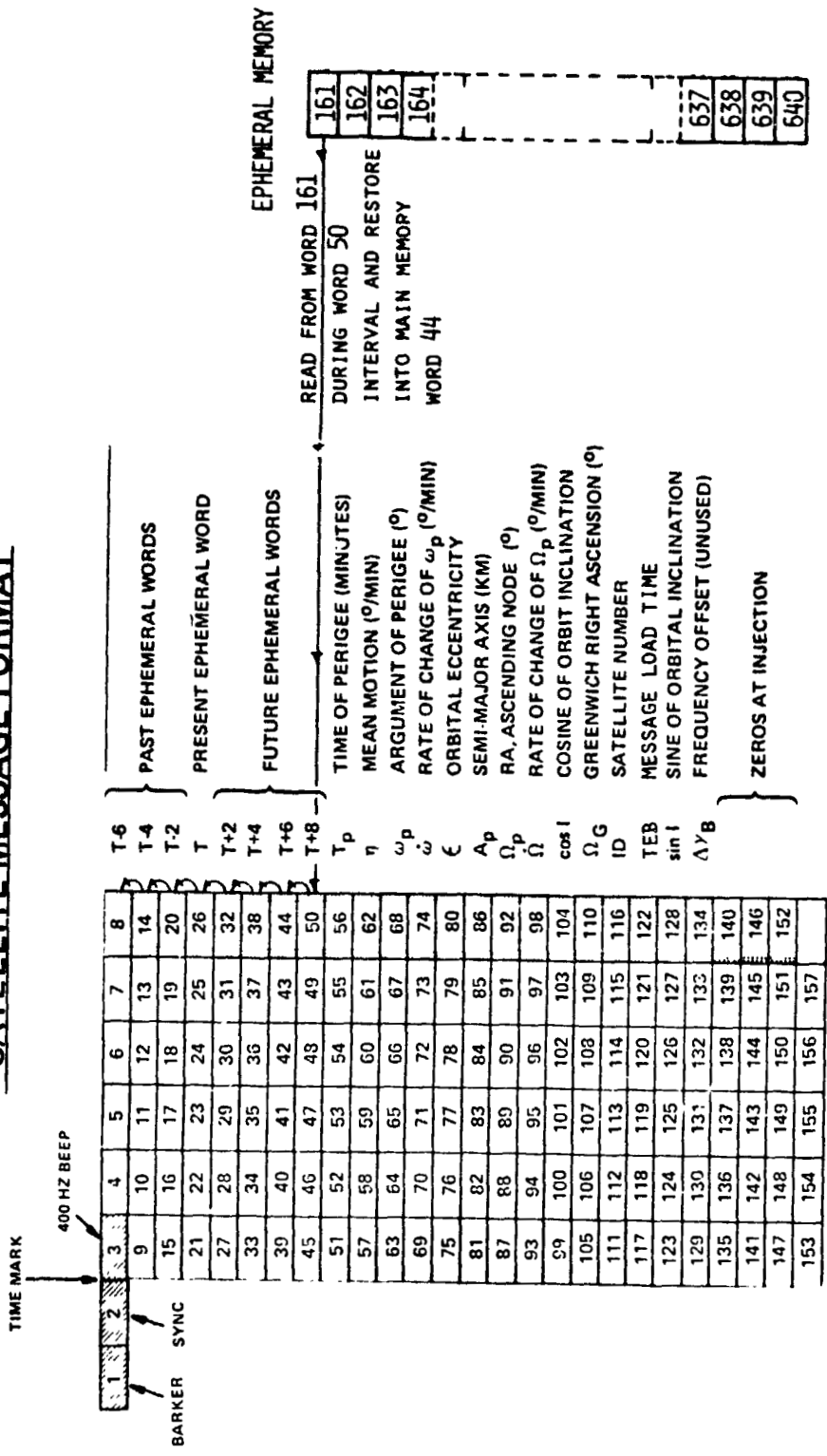

Figure 5. Satellite Message Format.

In addition to the words used for the navigation message, there are special words and bits which are used for certain satellite monitoring and control functions. The last three bits of all memory words fall into this category. Only the first 36 bits of each 39-bit word are used for message data. The last three bits of each have special functions; they are designated P, T, and C, for parity, telemetry, and clock correction, respectively. Of interest here are the clock correction bits, which are used to make fine corrections in the satellite timing. The 39th bit of most main memory words through word 136 and all ephemeral words is available as a clock correction bit.

The discussion of satellite hardware which allows these clock correction bits to function as a vernier time control is aided by reference to figure 6. At the top of this figure is the general block diagram illustrating the general features of TRANSIT signal generation previously discussed. We concentrate now on the divider chain (FREQ DIVIDE block) between the master oscillator and the MEMORY block.

This divider chain is constructed with sequential divisions of 16, 3, 2, 32, and 32, yielding a total frequency division of the master oscillator of 98,304. The memory read clock thus formed has a frequency of 50.859 Hz corresponding to a read period for each bit of 19.662373 milliseconds. Since the total message consists of 6103 bits, the transmission time is 119.9994624 seconds, which is 537.6 microseconds short of a precise two-minute interval. The adjustment of the memory read clock to a precise two-minute interval is made with the clock correction bits. Figure 6 shows this link is made via the ADJUST 9.6 μ SEC line from the MEMORY block to the FREQ DIVIDE block and constitutes the vernier time control.

The vernier time control system, called the *time normalizer*, operates as follows. Whenever a word is read from main memory, the 39th bit is checked for content. If it is a zero bit, satellite timing continues uninterrupted. However, if it is a one bit, a pulse activates the DELETE circuit. This circuit simply delays by exactly one period the signal at its input. This input signal frequency having been reduced from the master oscillator by a factor of 48, has a period 9.60 microseconds. This action delays all memory readout operations lengthening the duration of the bit, and hence the entire readout cycle by that amount.

Since each clock correction bit (if a one bit) lengthens the interval of the message readout by 9.6 microseconds, to achieve an exact two-minute interval $537.6 \text{ microseconds} \div 9.6 \text{ microseconds} = 56$ clock correction bits are required. This, of course, assumes a nominal master oscillator frequency of 4,999,600.0 Hz. To provide both positive and negative compensation about this nominal operating point, an additional 56 clock correction bits are required. This allows a time adjustment of ± 538 microseconds per two-minute interval. In fact, of the possible 156 words in main memory exactly 124 words are available (the remaining 32 are not used for various reasons). Since the change of a single time control bit in main memory results in a cumulative displacement of the FTM by 9.6 microseconds every two-minute period, over a period of 12 hours this amounts to a net displacement of the FTM of 3.456 milliseconds.

TRANSIT SIGNAL GENERATION

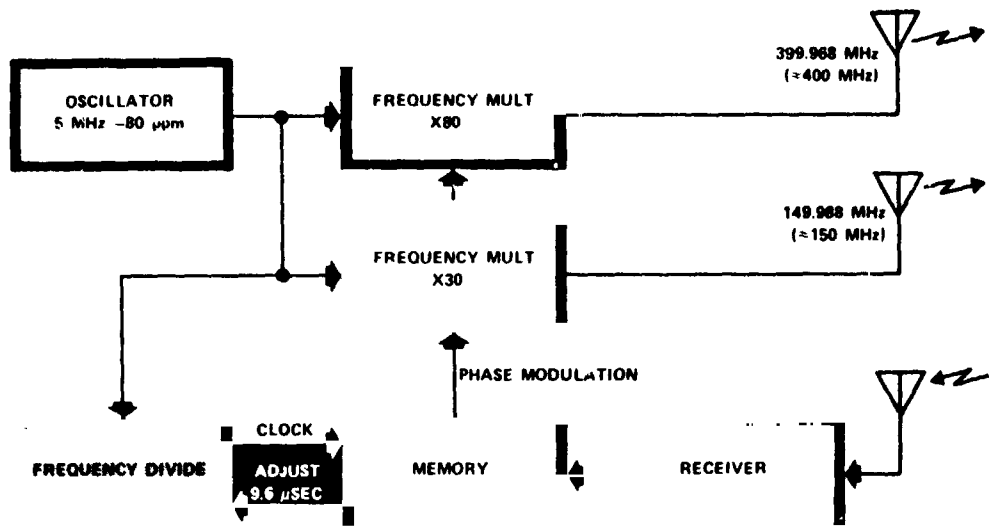

SATELLITE CLOCK CONTROL SYSTEM

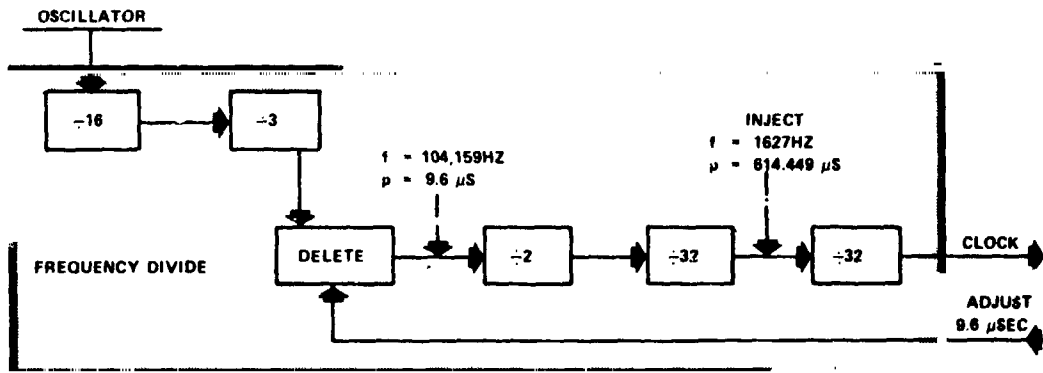

1. SATELLITE OSCILLATOR DESIGN CENTER FREQUENCY = 4,999,600
2. DIVIDER CHAIN RATIO (READ) = $16 \times 3 \times 2 \times 32 \times 32 = 98,304$
3. $98,304 / 4,999,600 = 19.662373 \text{ ms/BIT}$
4. $19.662373 \times 6103 = 119.9994626 \text{ SECONDS}$
5. $120.0000000 - 119.9994624 = 537.6 \mu\text{S}$
6. DIVIDER CHAIN RATIO (DELETE) = $48 / 4999600 = 9.6 \mu\text{S}$
7. $537.6 \mu\text{S} / 9.6 \mu\text{S} = 56 \text{ CLOCK CORRECTION BITS/2 MIN. INTERVALS}$

Figure 6. Satellite Clock Control System.

Finer control than that which can be obtained by inserting (or deleting) a full control bit each two-minute cycle is available in the form of clock correction bits stored in the ephemeral memory words. These bits are used only once, when they are read from the ephemeral memory at word 50, and thus they provide a unique correction for each individual two-minute interval. Since each bit is used only once in the entire normal 12-hour span between injections (which reload the memory), it has one three-hundred-sixtieth the effectiveness of the time correction bits in the main memory. *With proper use of these bits, together with those in main memory, it is theoretically possible to hold the clock on time to an accuracy of ± 4.8 microseconds over any 12-hour period.*

The operation of the *time normalizer* has been described in terms of time increments, but in practice its principal function will be to compensate for master oscillator frequency variations in such a way as to hold the length of the readout interval to exactly two minutes. When the oscillator speeds up, the proper number of additional one bits will be inserted as time correction bits to slow down the readout and maintain a constant cycle length. When the oscillator slows down corresponding bits will be removed to match. In this way, the clock can be held to a fixed two-minute cycle in synchronization with UTC. The amount of frequency compensation corresponding to a single clock correction bit is given by $48 \div 120 = 0.4$ Hz, since each bit controls a deletion of 48 cycles from the total two-minute interval. The total amount of control available, corresponding to ± 56 clock correction bits, is a frequency compensation of ± 22.4 Hz. It can be seen that this control is more than enough to cover the expected lifetime drift (± 10 Hz) of the oscillator with some left over for time synchronizing operations.

This, then, is the satellite clock system -- a stable oscillator driving the memory readout through a frequency divider chain. Synchronization of the FTM readout with UTC is achieved through control of the frequency divider chain using special (clock correction) bits embedded in the satellite message. Thus synchronization is controlled from the ground through the use of clock correction bits transmitted and stored in the satellite memory. In operation the system should constitute a precision clock which can be accurately synchronized with UTC.

To understand how TRANSIT time is maintained; i.e., how the proper number of clock correction bits is determined, we proceed to an operational description of the ground control system.

THE GROUND CONTROL SYSTEM

The ground control system consists of a tracking facility (TRAFAC), tracking and injection facilities (TRAINFAC's), and the Headquarters Computer Center. Figure 7 is a functional block diagram of a TRAFAC/TRAINFAC and the Headquarters Computer Center.

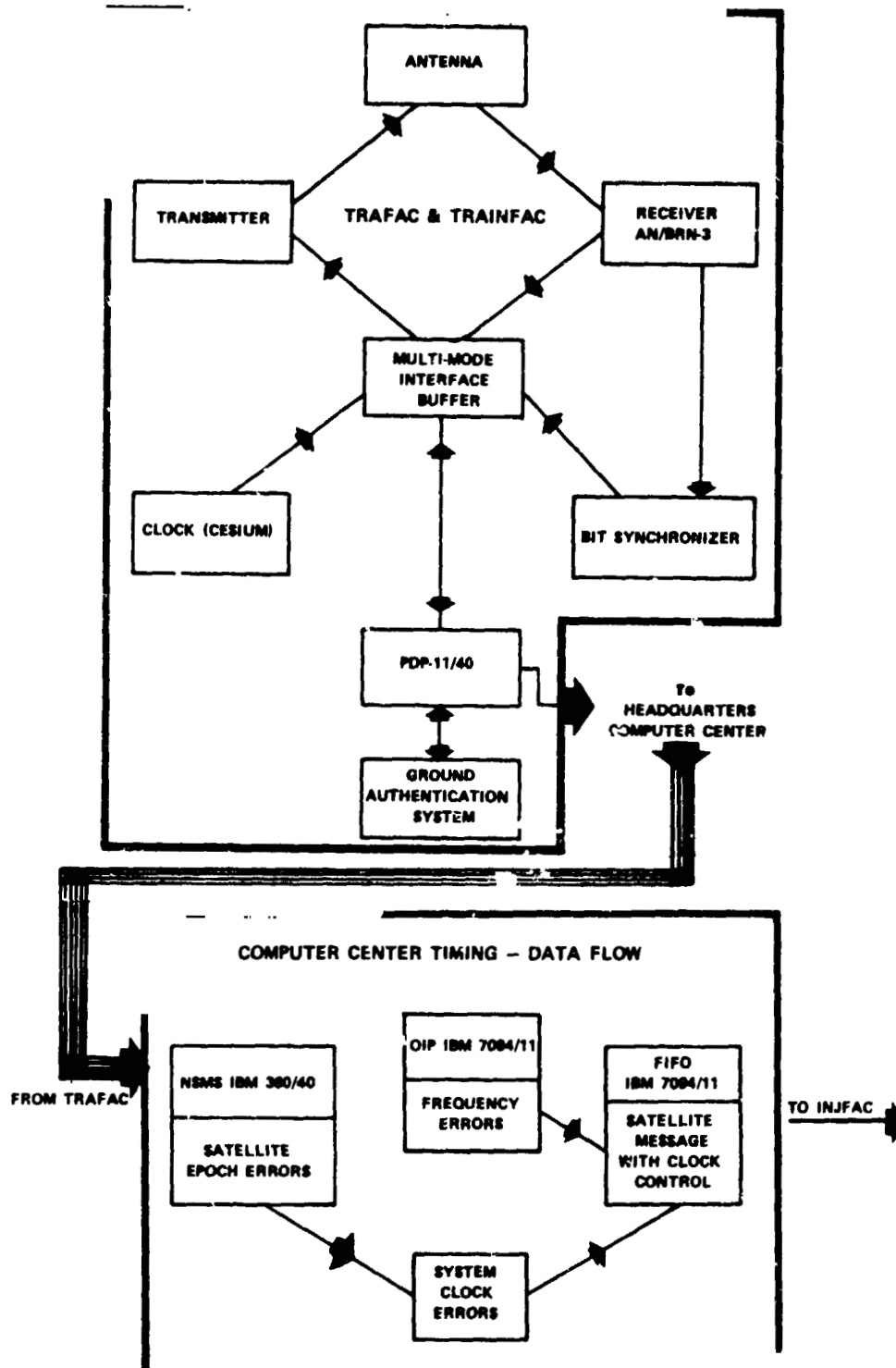

Figure 7. Functional Diagram of Ground System Facilities.

The principal function of the ground control system is to compute the proper pattern of time correction bits required to hold the clock on time with respect to the chosen referenced time, UTC. This calculation can be thought of as being carried out in two steps (although the results of both steps are, in practice, combined to form a single pattern of bits to be included in the injection message and transmitted to the satellite). First, the proper number of correction bits required to hold the desired *clock rate* is determined according to the current oscillator frequency. Second, the number of bits needed to correct any error in the *clock epoch* is calculated in such a way that the error will be removed over a normal 12-hour injection period.

Doppler and timing information collected by the TRAFAC from a TRANSIT satellite pass is sent to the Headquarters Computer Center. The timing data are processed in near real time by the NAVASTROGRU Satellite Monitoring System (NSMS) programs. In this program raw timing data consisting of received FTM's relative to the TRAFAC Cesium clock are processed to obtain the FTM epoch referenced to the satellite and relative to UTC. The output of the NSMS is a plot of the time errors associated with passes over a time span of the previous 36 hours. From this plot, a judgment is made by an analyst as to the clock epoch error. An example of this plot is shown in figure 8. The expected epoch error, in this case 30 microseconds, will be sent to the Final Formatting (FIFO) program. In addition, a second input to FIFO is the result of the Doppler data analysis. From this analysis, the master oscillator frequency and drift rate are computed at a predetermined epoch and linearly extrapolated over the injection message readout span. (The program providing this analysis, the Orbital Improvement Program (OIP), also supplies the updated ephemeris for the next injection span.)

With the inputs of satellite clock epoch error and oscillator drift rate, FIFO calculates and inserts the proper number of clock correction bits into the injection message. Subsequently, these injection messages are transmitted to the TRAINFAC for injection in the proper satellite at the proper time.

CURRENT TRANSIT TIME ACCURACY

Having delineated how the NNSS generates and maintains TRANSIT satellite time, consideration will be given to the limitations imposed by the hardware and the current time dissemination accuracy of the TRANSIT satellites.

Although the inherent limit to timing precision is that of the satellite clock (9.6 microseconds), this limit is rarely an impediment in the current operational system. All TRAINFAC's use an AN/BRN-3 navigation receiver which can recover a single FTM with a precision of approximately 35 microseconds (1σ). The signal delay time from the AN/BRN-3 receiver, although measured weekly, is a function of many variables, and the correction uncertainty is approximately 15 microseconds (1σ). In the tracking of a single pass an average of six FTM datum points is recovered, thus improving the time precision by a factor of $\sqrt{6}$. Each TRAINFAC is equipped with a cesium clock whose time with respect to UTC is maintained (via traveling clock checks) within five microseconds (1σ). Thus, the expected precision in a time measurement of a single pass of a TRANSIT satellite within the NNSS is 19 microseconds (1σ).

SATELLITE 30200 NSMS EPOCH ERRORS

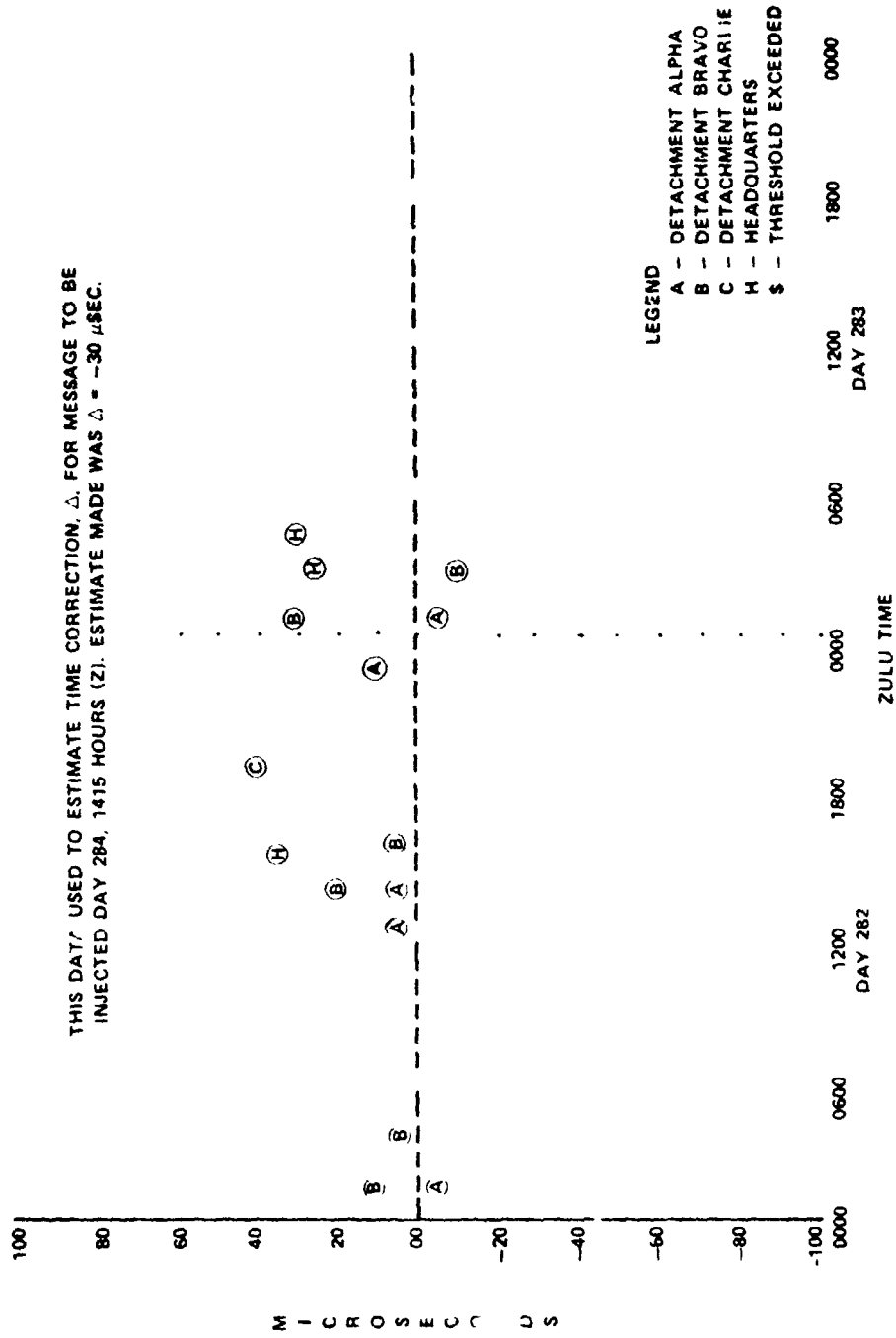

Figure 8. Satellite 30200 NSMS Epoch Errors.

With this basic hardware limitation of measurement precision, figures 9 and 10 exemplify the current accuracy of each TRANSIT satellite referenced to UTC.

Immediately apparent is the disparity in time accuracy between the older and newer satellites. The data base for each satellite consisted of over 1200 passes averaged over all tracking stations. Special problems with the two oldest satellites are understood: satellite 30120 has reduced power on the transmission of the 400-MHz carrier; and on satellite 30130 the 150-MHz transmission has the satellite telemetry signal (2.3 kHz) superimposed on it. The single-pass accuracy of the system (all satellites combined) is approximately 19 microseconds (1σ).

Another feature apparent in the time accuracy histograms is the relative frequency of satellite clock errors over 70 microseconds. The sources of these errors are satellite oscillator jumps and ground station injection problems. However, these problems are known at the time of their occurrence and corrected within a reasonable time frame. Table 1 illustrates the NNSS operational time dissemination reliability maintained over the previous four years.

TIME IMPROVEMENT PROGRAM

Improvement in TRANSIT timing accuracy in the near future should be considered in terms of measurability and controllability. Both aspects are limited ultimately by the satellite clock. The most important limitations in practice, however, are delays throughout the feedback loop of the control operation. This limitation becomes critical when compounded by limitations on measurability. When time thresholds are implemented which require quick and serious response, it is imperative that reliable confirmation be obtained as to the time measurement in question.

Feasibility of improved measurability was made possible by the introduction last year of a new TRANSIT timing receiver by Satellite Navigation Systems, Inc. A paper on the Model T-200 Satellite Timing Receiver was presented at the N. 11th Annual PTTI conference (1977). Suffice it to say that initial evaluations indicate a time recovery capability comparable to the NSMS. This receiver, if used at each TRAFAC, would give an independent measure of time for each satellite tracked, thereby redundantly doubling the number of datum points per pass. This allows a more reliable determination of satellite timing which ultimately results in better control.

Feasibility of improved controllability would come through NAVASTROGRU operational procedure changes. To illustrate the extent of the delay in the control loop consider figure 8 again. The estimate of the clock epoch error was made as of 1600Z on day 283.

The correction, -30 microseconds, was injected into the satellite memory at 1415Z on day 284. The corresponding clock correction bits were spread as uniformly as possible throughout the 12-hour readout period. This is a delay in correcting a known clock error of 36 hours! Obviously any time improvement program initiated by NAVASTROGRU will place high priority on shortening this control loop delay.

SATELLITE 30120

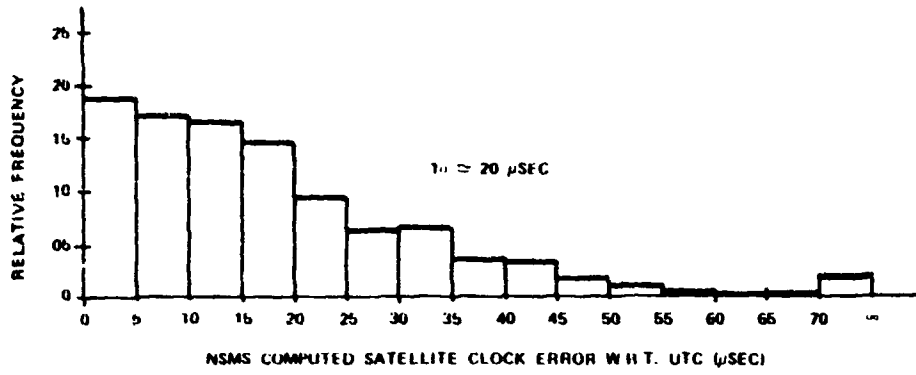

SATELLITE 30130

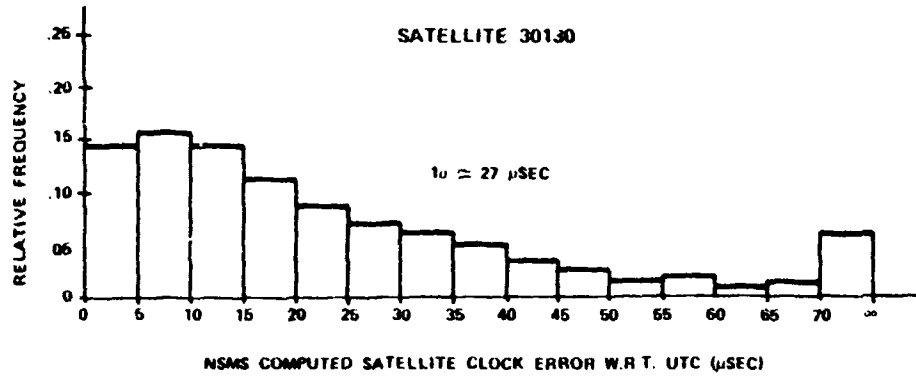

SATELLITE 30140

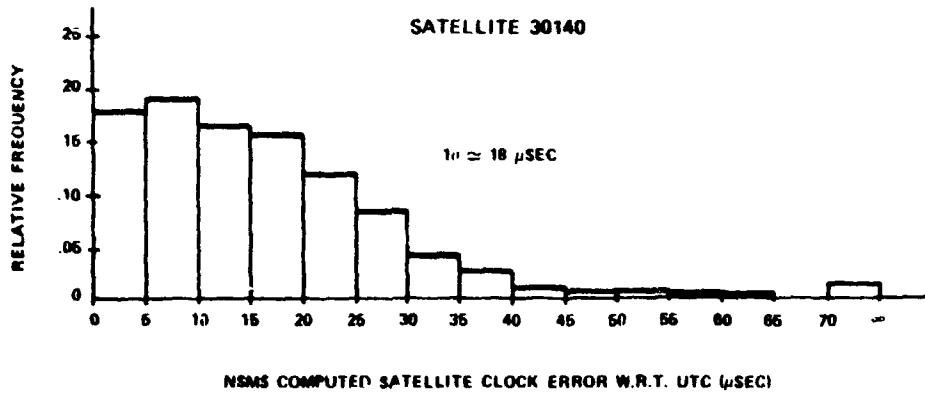

Figure 9. NSMS Computed Satellite Clock Errors with Respect to UTC.

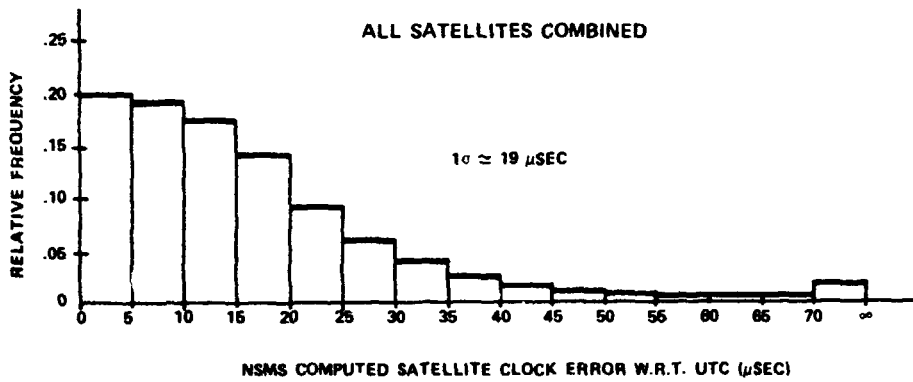
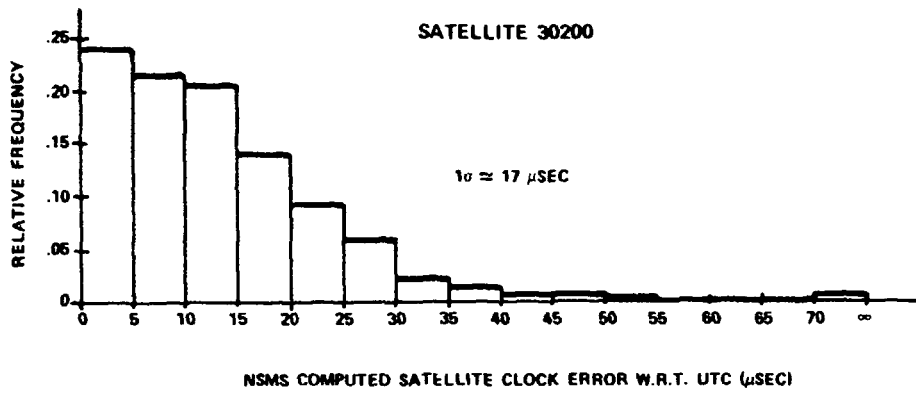
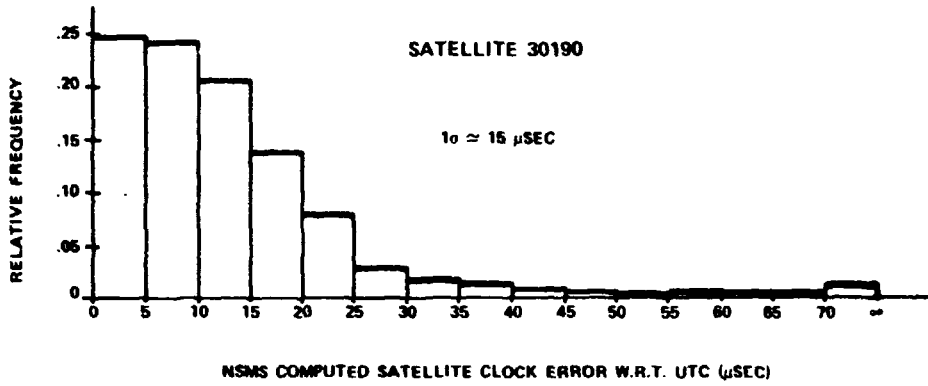

Figure 10. NSMS Computed Satellite Clock Errors with Respect to UTC.

TABLE I. NNSS OPERATIONAL TIME DISSEMINATION RELIABILITY

SATELLITE BROADCAST EPOCH > 100 μ SEC	
YEAR	INSTANCES
1978	5
1977	8
1976	14
1975	7
1974	4
CATEGORIES OF SATELLITE TIMING ANOMALIES	
- DETACHMENT INJECTION UPLINK	33
- SATELLITE HARDWARE MALFUNCTION	4
- OIP FREQUENCY MISPREDICTION	1
RELIABILITY	
<ul style="list-style-type: none"> - PERIOD SINCE 1 JANUARY 1974 - APPROX 233,000 BROADCAST HOURS - APPROX 1088 HOURS SAT CLOCK > 100 μSEC - RELIABILITY = 99.5% 	

The following hardware-related modifications are expected, either directly or indirectly, to improve the accuracy of time disseminated by the TRANSIT satellite system.

1. If, in the current joint evaluation (by NAVOBSY and NAVASTROGRU) the TRANSIT timing receiver performs as well as initial tests indicate, NAVASTROGRU will request (of DIRSSP) deployment of one receiver to each detachment.

2. Continual upgrading of supplementary helix tracking antennas at all TRAINFAC's for improved reception of satellite signals. This is especially important as we enter a period of high solar activity.

3. Deployment of a second cesium clock to the detachments at Maine, Minnesota, and California to improve the quasi-yearly checks by NAVOBSY.

4. The use of TV Line-10 from Los Angeles KTTV (Channel 11) by Headquarters as a continual link to UTC by the TRANSIT System. (As of November, 1978, this TV Line-10 source is still not operational.)

Software-related improvements are under consideration but are more tenuous due to cost factors. They would consist mainly of improvements to the NSMS timing program.

In summary, the operational TRANSIT System meets the current NNSS timing objectives. NAVASTROGRU feels that with the introduction of the hardware and operational changes mentioned above, anticipated NNSS requirements specific to timing accuracy can also be met. Any further requirement, however, for time transfer to a higher degree of precision on a continuous basis must be established through the Chief of Naval Operations.

QUESTIONS AND ANSWERS

MR. LAUREN J. RUEGER, Johns Hopkins University, Applied Physics Lab:

I feel impelled to defend the AN/BRN-3 Receiver design, as I had a part in its development. It was designed to meet a specification of 100 microsecond time recovery in 1969 and I am a bit surprised that it exceeded that by as large a margin as you have shown. You did not mention the specification of the navigation system for timing at the present time. Do you want to mention that?

DR. FINSOD:

Yes. There is no timing specification now. Our primary mission, which is navigation, determines that. In those terms, people don't get excited until they see 1,000 microseconds deviation; then the duty officers, or the controllers, get excited. I call them up when the deviation is about 200 microseconds and I start recovery action at around 20 microseconds. So, because there is no specific requirement, it is quite a mess in determining who gets excited when, but we do definitely make changes. When there is a 20 microsecond deviation, we do put in delts, what we call delts, or corrections.

MR. RUEGER:

I thought there was in the works some requirement to hold 200 microseconds relative to the Naval Observatory.

DR. FINSOD:

Right.

MR. RUEGER:

Is that not in effect yet?

DR. FINSOD:

It is public knowledge that the requirements that we are talking about, which are coming downstream soon, are to maintain no more than a 70 microsecond difference in any satellite clock on an orbit-to-orbit return. In other words, you go around twice and you can't deviate more than 70 microseconds, nor can you allow any more than 200 microseconds at any time on any satellite.

DR. ALFRED KAHAN, Rome Air Development Center:

Can you comment about the physical performance of the oscillators for those last ten years. For example, have you observed any solar activity on those oscillators?

DR. FINSOD:

If there has been, I don't believe that we have seen it. On the older satellites, we have had oscillator jumps, but I think that is completely unrelated. We have found no timing problems related to

solar activity, except those caused by increased scintillation of the ionosphere, which causes problems in reading time. But we have seen no evidence, that is, they are maintaining their offset of 80 parts per million within something like 50 parts per 300 million. I mean, that is sort of the worst offset we have to the requirement, and this is after 11 years. There has not been any correlation that we have seen.

I think Mr. Rueger would like to comment.

MR. RUEGER:

We do have data on that subject and we observed the natural radiation effects on the crystal oscillators which I suspect you are seeing. The normal aging drift in these oscillators is up in frequency, but down in frequency from the radiation effects of trapped electrons in orbit. The upward drift is linear with time; the downward drift from radiation dose is logarithmic with time. So, all these satellites drifted slightly down, at first, and then they eventually are dominated by the linear function and drift upward. These oscillators have had such a large dose by now that even fairly substantial solar flares cause almost no effects.

We did observe, when we had some very large solar flares on occasion, a jump of the frequency during the early life in orbit by as much as 4 parts in 10^9 . We have records of the frequency as a function of time which you can plot yourself from the Naval Observatory Bulletin 17 literature. Those numbers come from the Naval Astronautics Group and are then reissued by USNO to the public through the Bulletin 17.

MR. FRAUHOFF, Efratom California:

With the clock specs that you have, what is the one sigma navigation solution that the man comes up with? Did I mishear that or had that been mentioned?

DR. FINSOD:

I am not sure I quite understand. It sounds like a question that might be directed to our first speaker. Are you talking about the corresponding navigational error?

MR. FRAUHOFF:

Yes.

DR. CHARLES MARTIN, Defense Mapping Agency:

It is based on a single pass.

DR. FINSOD:

Based on a single pass. I don't know that figure off hand. Bob Payne might be able to add something to that.

MR. ROBERT PAYNE, Naval Astronautics Group:

As Dr. Finsod pointed out, our timing is controlled within the auspices of our navigation today and the navigation resolution is on the order of about 3/100 of a nautical mile, about 52 meters, that we can maintain very well over any 24 hour arc. Now, we have been experiencing increased solar activity, and, as you gentlemen know, it does have quite an effect on navigation. We have seen problems that have increased that number by a magnitude of 2 over what I said, so .06 or .07 nautical miles is not unreasonable for very high K or very high values of S average.

SPEAKER:

This comment, I think, gets closer to the answer that he asked.

DR. FINSOD:

Yes, I understood the question was about the clock performance on navigation accuracy and the number I was giving was something of the order of 10 centimeters to a meter, depending on what oscillator you are dealing with. I think the errors you are speaking about are mainly from ephemerous errors rather than from oscillator errors. That perhaps was not what he was asking.

MR. DOUGLAS TENNANT, GPS Program Office:

I am curious to know if you have experienced anything like discreet frequency shifts in the clocks?

DR. FINSOD:

Yes. In fact, a number within the last three or four months, particularly, I think in Satellite 13, or 30130, but we have found no correlation between these and any other activity.

MR. TENNANT:

How about solar activity?

DR. FINSOD:

No. I mean, that is, none of the other satellites have the jumps and the jumps do not occur very often--once every six months usually, which causes, of course, a serious timing problem until it can be corrected.

MR. TENNANT:

In GPS, we have seen discrete frequency shifts which we have correlated to substorms on the sun. I wonder if you had a common experience?

DR. FINSOD:

No, although recently we have been trying to find some correlation because our navigation has deteriorated somewhat, although not out of specifications, and we could find no correlation in the K

indices. But apparently there was high auroral activity, high solar proton activity in the northern latitude where our tracking stations are located, especially detachment BRAVO which is in Minnesota, and detachment ALPHA which is in Maine. So, when we have problems, it is hard to separate out the problems caused by from an excited ionosphere and those that correspond to the actual satellite being bombarded by radiation.

So, we haven't been able to determine any correlations.