

2001/2/2

A Long-Range and Long-Life Telemetry Data-Acquisition System for Heart Rate and Multiple Body Temperatures From Free-Ranging Animals

Gordon F. Lund, Richard M. Westbrook,
Thomas B. Fryer, and Rafael F. Miranda

{NASA-TM-78590} A LONG-RANGE AND LONG-LIFE TELEMETRY DATA-ACQUISITION SYSTEM FOR HEART RATE AND MULTIPLE BODY TEMPERATURES FROM FREE-RANGING ANIMALS (NASA) 74 p HC A04/MF A01	N79-26762 Unclas 23482 CSCL 06B G3/51
--	--

May 1979



A Long-Range and Long-Life Telemetry Data-Acquisition System for Heart Rate and Multiple Body Temperatures From Free-Ranging Animals

George F. Lund
Richard M. Westbrook
Thomas B. Fryer
Rafael F. Miranda, Ames Research Center, Moffett Field, California



National Aeronautics and
Space Administration

Ames Research Center
Moffett Field, California 94035

A LONG-RANGE AND LONG-LIFE TELEMETRY DATA-ACQUISITION SYSTEM
FOR HEART RATE AND MULTIPLE BODY TEMPERATURES
FROM FREE-RANGING ANIMALS

Gordon F. Lund,* Richard M. Westbrook,
Thomas B. Fryer, and Rafael F. Miranda

Ames Research Center

SUMMARY

A long-range and long-life telemetry system for heart rate and multiple body temperatures from free-ranging animals has been designed. This system includes an implantable transmitter, external receiver-retransmitter collar, and a microprocessor-controlled demodulator. The size of the implant is suitable for animals with body weights of a few kilograms or more; further size reduction of the implant is possible. The ECG is sensed by electrodes designed for internal telemetry and to reduce movement artifacts. The R-wave characteristics are then specifically selected to trigger a short radio frequency (RF) pulse. Temperatures are sensed at desired locations by thermistors and then, based on a heartbeat counter, transmitted intermittently via pulse interval modulation. This modulation scheme includes first and last calibration intervals for a reference by ratios with the temperature intervals to achieve good accuracy even over long periods. Pulse duration and pulse sequencing are used to discriminate between heart rate and temperature pulses as well as RF interference. The implanted transmitter might be used alone for experiments on animals that frequent particular locations within a large territory; on animals in virtually any laboratory situation; or on animals in moderate-sized enclosures, such as those in a zoological garden. The implanted transmitter is otherwise interfaced with the receiver-retransmitter collar that employs commercial tracking equipment to achieve the long-range transmission. Peak energy is consumed only during the short RF pulses so that average current drain of either transmitter is in the range of tenths of milliamperes. The RF pulses from either transmitter are processed by the microprocessor controlled demodulator for the characteristics of pulse durations, intervals, and sequence. The output provides analog beat-to-beat heart rate and periodically updated temperatures as well as digital display. Heart rates to several hundred beats per minute (BPM) and body temperatures within a range of zero to 50° C with 0.1° C in resolution of change or better seem feasible. The objective of the design was to achieve a high degree of experimental flexibility and overall high quality in performance. The system was tested in prototype form on a dog.

*National Research Council Assoc.; Adj. Assoc. Prof., San Jose State Univ., CA

ORIGINAL PAGE IS
OF POOR QUALITY

INTRODUCTION

This report presents the design details and rationale of an experimentally versatile, long-range, long-life, telemetry data-acquisition system for heart rate and multiple body temperatures. The design comprises an implantable transmitter for short to medium range, a receiver/retransmitter collar to be worn by the animal for long-range transmission, and a microprocessor-controlled demodulator with a signal conditioner interface circuit. The other receivers and equipment that were used, including the collar transmitter, were obtained commercially.

The parameters of heart rate and temperatures were selected for this design for two major reasons. First, they have a low data rate requirement so that signal modulation is compatible with the same principles of operation of the small, long-range, long-life, telemetry tracking systems. Specifically, the radio frequency (RF) pulses can be infrequent and several milliseconds long as well as frequency-stable. These pulse characteristics allow narrow-band reception and pulse width discrimination in order to achieve the effective long transmission range at low power costs. Tracking systems have long been available and widely used (refs. 1,2).

Second, these parameters are substantially influenced, either directly or indirectly, by both the autonomic and central nervous systems, by the endocrine system, and by metabolism. Heart rate and temperatures, particularly in combinations, can therefore inherently serve to index many and various interactive responses of animals to their environments. These responses would include changes in activity, emotions, health, energy allocations, behavioral patterns, and biological rhythms. Illustrative examples have been presented elsewhere (e.g., refs. 3-5).

These parameters also require animal instrumentation techniques that are acceptable and not too difficult to use in a diversity of studies and environmental situations. That is, compared to the data of a tracking signal only, the gain of information from physiological data about the responses of an animal can far outweigh the added costs in the necessary initial procedural efforts of animal instrumentation.

Reviews and reference lists of the state of the art of physiological telemetry have been presented periodically (refs. 2,6-8). Pulse-interval modulation (PIM) in the telemetry designs for heart rate or temperatures is not uncommon (refs. 9-14). At least one design effort also has been able to obtain heart rates at long range with implanted and external relay transmitters (refs. 15,16). A temperature channel has recently been added to that system (Long, Department of Engineering, University of Wyoming, personal communication). Also, statements for the justification of studies that require physiological data from free-ranging animals and for the needs of associated research and development were prepared as a report from a NASA-sponsored 1973 Santa Cruz Summer Study and a subsequent Program Plan on Wildlife Monitoring (ref. 17). In short, the technical feasibility of a research approach and the justification for it have been demonstrated.

From the practical experimental point of view, however, the critical factor is the achievement of the quality of performance required to realize sampling procedures in experimental designs that are inherent in the idea of the use of indices. That is (except in the simpler applications), indices based on physiological parameters, such as heart rate and body temperatures, to assess animal responses will often require more or less continuous records over time in order to note relative changes. These changes can then be related to the experimental context and to the stimuli that give rise to the responses. Thus, large volumes of data are generated, and a high degree of automated data processing is virtually mandatory.

The system to be described here offers a heart rate and multiple body temperature capability but, in addition, has a number of features and advantages to improve signal quality and to increase experimental flexibility. The specific details of the circuits presented here represent a prototype that was designed, constructed, and tested in a Labrador dog at the Ames Research Center. A descriptive overview of the performance characteristics and design problems is presented first.

This work was initiated under the support umbrella of The National Research Council's Resident Research Associate Program and was continued, in part, through a grant (NSG 2293).

OVERVIEW

The implantable transmitter generates a radio frequency (RF) pulse of several milliseconds duration for each heartbeat. These pulses are triggered from the specifically selected biopotential R-wave characteristics of the electrocardiogram (ECG). Tests with the prototype show that the R-wave detection is highly reliable. A crystal controlled oscillator is used to achieve the narrow-band, high-power density, and frequency-stable RF pulses.

Periodically, the transmitter's operation changes as determined by a heartbeat counter. This is set to be every 50 heartbeats in the prototype. A series of PIM temperature RF pulses are then transmitted within an approximate 1-2-sec window. This temperature pulse series is at the same RF as that for the heartbeats, but the pulse durations are approximately doubled. The modulation scheme includes a two-point interval calibration that helps to achieve continued accuracy over time with good measurement resolution over a wide temperature range.

These RF signal characteristics are then received either directly at short to medium range or after relay through the collar for long range. In either case, the received signals are appropriately conditioned by an interface circuitry and then processed by the microprocessor. The interface circuitry is adapted to condition a tone-burst output, in order to make it compatible with commercial tracking receivers and field tape recorders that might be used for temporary data storage. The microprocessor then sorts the

pulses according to their widths and to the programmed data treatment for the other signal characteristics to give digital or analog outputs.

Since temperature variations occur slowly, the periodic cycle for transmission of data avoids unnecessary redundancy and conserves power both for transmission and for circuit operation. Also, the rates of change in temperature data are often correlated with heart rates so that sampling redundancy inherently increases with heart rate. The R-waves are still detected and counted by the implanted transmitter so that no information on the number of heartbeats is lost during temperature transmission. Because the temperature window is short, only a little heartbeat-to-beat information is lost.

On the other hand, the transmission of each heartbeat does not involve unnecessary redundancy. That is, animals that weigh only a few kilograms spend most of their time resting or engaged in moderate activity; their heart rates are then slow and match approximately a convenient pulse rate for location and tracking. The transmitter's duty cycle is still low so that further power reduction through reduced transmission rates is not really necessary. Operation time from several months to more than a year can be achieved, even within a small animal. Also, many experiments will require combinations between average heart rates for periods of time and beat-to-beat changes at other times. Such decisions about these formats are better made when processing the data. In this regard, the temperature cycle can be flagged optionally to obtain averages.

Figure 1 illustrates the various ways to interface the equipment for experiment flexibility.

Temperature Modulation

The modulation scheme for temperatures is illustrated in figure 2. The scheme involves ratios with the calibration values that are based on fixed resistors within the transmitter's circuitry. The fixed resistors determine the first and last intervals of the series of temperature pulses. The intermediate intervals of the series are assigned sequentially to the respective thermistors; there could be several thermistors if desired, but only two are used in the prototype design. The interval between the 50th heartbeat that triggers the series and the first temperature pulse is also determined by the same calibration resistor. After the last temperature pulse, a brief delay is insured before the next transmitted heart pulse is permitted so that pulse separation always occurs. The fixed-calibration resistors are selected to correspond to the highest and lowest resistances of the thermistors used and the range of temperatures anticipated in experiments. A measured temperature interval is therefore a percentage of the range defined by the calibration intervals and is then related to the known thermistor temperature curves.

The ability to define limits for acceptance in demodulation of the pulse durations, intervals, and sequence characteristics helps guard against

error. In addition, however, it allows the absence of error to be recognized automatically. That is, the microprocessor will not update unless conditions are met, and this fact can be known in an automated way. This is important when a telemetry system is used near the limits of its capabilities. Under such conditions, the feature of doubling the temperature pulses also inherently yields a periodic stronger signal. This flag, at least, helps to maintain the record of average heart rates when the noise interference for good beat-to-beat information is too great.

Because the relationship between the fixed resistors and thermistors is proportional, changes in circuit characteristics and power levels over time minimally influence accuracy. Because all the information for the PIM is transmitted in a short period of time, the variation in detection of the leading edges of the pulses ("jitter") within the pulse series should be slight. The degree of jitter from one pulse series to the next is of little concern. For example, a temperature range of 50° C with 0.1° C measurement resolution seems feasible within an average time requirement of less than 0.5 sec per temperature channel. The average from sample redundancy should improve this resolution.

R-Wave Detection

The quality of performance of this and similar heart-rate telemetry systems depends first on the reliability of the R-wave detection independent of the animal's activity. Body movements and the choice of electrode locations may cause variations of amplitudes, waveforms, and polarity of the ECG signals. There may be large and rapid changes in the regularity and frequency of heartbeats, and unwanted signals from various sources may cause false triggering. The idea of a chronic implant within a healthy and free-ranging animal must be kept in mind when trying to achieve an optimum degree of success to correct for these problems. The implant must be packaged adequately, and appropriate surgical procedures must be followed in addition to giving considerations to both sensor and circuit design. Simplicity and economy are desired for any solution, but not at the expense of experimental objectives and performance requirements. The optimum also will not be identical for different species or, for that matter, for different experiments with the same species. The direction taken here allows design and procedural variations to be made easily and noninteractively.

A reasonably good first approach when the transmitter is implanted is to locate the electrodes subcutaneously on the thoracic region. The R-wave amplitudes tend to be greater when one electrode is referenced to the other located near the apex of the heart and relative to the heart's electrical axis. Amplitudes within the ranges of several tenths of a millivolt to several millivolts will often be obtained, but this depends on the species as well as on electrode location.

The frequency spectrum for the ECG is 0.1 - 100 Hz. Empirical examination with the use of filters will indicate that dominant frequency

components of R-waves occur at about 20 Hz. This is somewhat dependent on heart size and rates. Filtering above that frequency substantially reduces the electromyogram (EMG) in which the frequency components begin at about 30 to 50 Hz. The amplitudes of the EMG tend predominantly to be less than a few tenths of a millivolt unless a major muscle mass is involved. Skeletal muscle is anatomically unlike that which produces the behavior of an electrical syncytium in cardiac muscle. A strong electrical axis between highly coordinated polarized and depolarized regions over a long distance, as from the heart, does not occur. Location of electrodes away from muscle is therefore beneficial.

Low-frequency signals within a few hertz, such as those caused by respiratory movements, are filtered also. But amplitude changes in the signals of successive heartbeats can be substantial because of the influence of thoracic changes on the electrical axis. Changes in body position, which shift tissues and organs, also influence the electrical axis. Beat-to-beat changes in amplitudes in excess of 40% tend to be very rare and are usually much less if care is taken; however, amplitude changes over time are of course greater. It is important, therefore, to select electrode locations to reduce this variation as well as to maximize R-wave amplitude. Signal polarity changes are controlled by rectifying the signals. Automatically adjusting thresholds help to compensate for amplitude variations and to maximize noise discrimination whenever possible.

There is a variety of other signal detection problems. Excessively large potentials, which can occur, can overdrive the amplifier; discontinuous signals can cause ringing oscillation within circuits; and accentuated T-waves may occur with respect, in part, to electrode placement and cause double triggering. T-waves can usually be controlled to be less than 50% of the R-waves. P-waves tend to be much smaller but do precede the R-wave. Fortunately, the wave forms of the ECG tend to keep a degree of amplitude proportionality so that automatically adjusting thresholds have considerable benefit. Triggering from RF feedback within the circuit or through external leads requires appropriate preventive measures, such as filtering and packaging. Spikes from stress at lead connections can occur if proper care is not taken. Lead movements can induce potential differences at the transmitter's input when the leads are separated and when there is a high impedance. This problem is reduced when the transmitter is inside the animal's body but might be heightened by a strong RF field during signal outputs. Changes of the transmembrane potentials of cells due to pressures of electrodes, and as different from activation potentials, might occur also.

In practice, many of the unwanted noise artifacts occur in the form of spike bursts rather than single spikes. A few of the spikes in a burst will have higher amplitudes than most of the others. Although these spikes are often close together, their amplitudes may exceed a triggering threshold. Rapid retriggering might occur unless limited. Nevertheless, such limits must not exceed requirements for maximum heart rates. Maximum heart rates of animals that weigh more than 1 or 2 kg rarely exceed an upper limit of as much as 8/sec. This allows 125 msec as a minimum limit for retriggering

and that limit could be extended if maximum rates are lower. This minimum limit for retriggering also helps to traverse the intervals of rectified waveform complexes and might be extended to overlap T-waves. Electrode movement artifacts can be a major problem because their signal amplitudes and frequency components range widely and overlap those of R-waves. Appropriate electrode design and implant procedures are critical here, and some suggestions will be made shortly.

In effect, the circuit design for the detection of R-waves places a window for signal characteristics among those anticipated after appropriate animal instrumentation procedures are followed. Sharp high- and low-pass filtering limits the frequency components above and below about 20 Hz. A limit on the accepted rate of change of slope of an incoming signal is also used. Amplifier gain control during RF pulses helps reduce feedback in addition to filtering. Full-wave rectification reduces polarity reversal problems and is combined with limits on retriggering rates. An absolute minimum amplitude threshold is set at about ± 0.3 mV to keep above low-level signals and noise. Minimum R-wave amplitudes therefore must exceed this level. In addition, the triggering threshold automatically and proportionally adjusts itself above this minimum to accommodate beat-to-beat amplitude variations and anticipated durations of rectified waveform complexes, such as noise bursts. Precautions are taken to ensure rapid recovery in performance of the circuits, should unusual input signals occur

Again, the design is flexible so that adjustment in the specifications for performance requirements are largely noninteractive. The design is complex, but makes efficient use of available low-powered integrated circuits for construction. Also, the advantages that can be gained, if R-wave detection is accomplished reliably by the implanted transmitter, substantially overshadow the subsequent problems and limitations associated with complex waveform transmission of the ECG when only heart rate ultimately is required.

Electrodes

Relatively small structures, such as wires, needles, and lead-loop extensions of stainless steel are often suggested for chronically implanted ECG electrodes (refs. 18-22). Stainless steel is a convenient metal to use and is tolerated reasonably well by tissue; an alternative metal like silver is less durable and somewhat toxic (ref. 23). The small mass is advocated to reduce inertia problems and, because the skin boundary encountered by external electrodes is absent, the impedance of an internal stainless steel electrode is relatively low even for small structures that have areas of only a few square millimeters (refs. 19,20,24). Secure suturing, the promotion of tissue imbedding, and an appropriate choice of locations where body movements are minimal are often indicated procedures to reduce movement artifact problems. Neuman (ref. 22) recently illustrated that a multi-stranded lead-loop extension is a typical design commonly used for internal telemetry.

These electrode styles are not recommended here. A large distributed area, smooth, thin, and inflexible stainless steel disc is a better yet still simple design that is suitable for chronic subcutaneous implants in active animals. An example that is compared with a lead-loop extension is illustrated in figure 3. This particular construction involves a groove and plurality of holes into which the lead is fitted with support tabs and spot welded into place. Silicone RTV coats and supports the entire region of connection and binds to itself across the holes in the disc as well as to the disc. The RTV also is tapered to the lead to reduce flexure stress. The four holes near the periphery allow the disc to be firmly sutured in place so that lead movements do not dominate electrode movement, as is the case with a small mass electrode.

Figure 4 shows the considerable difference in signal quality that can occur between the disc and lead-loop extension electrodes that were illustrated in figure 3 and when in vivo. For these records, the electrodes had been implanted 1 week earlier in a dog; they were placed side by side subcutaneously in the lead II configuration across the sternum. The leads passed transcutaneously and were connected by clips to the recorder with one pair for recording while other test pairs served for ground. Filters were set at 1.0-100 Hz; the preamplifier input impedance was 200 kohms. The dog was kept walking in a circle with side steps of the forelegs. The records were made sequentially with disc electrodes in A, and then with lead loop extensions in B. Rubbing the skin directly over the electrodes produced an even greater difference in signal quality.

Figure 5 illustrates in vitro records from these two electrode styles when one member of a pair in a 0.9% saline bath was rubbed between the fingers in an attempt to simulate the in vivo condition. The records of the potential changes of disc electrodes (A&C) and lead loop extensions (B&D) are labelled respectively. The records A&B show the direct current potential changes; filters were set at 10-100 Hz for the records in C&D. A 10 Mohm input impedance probe was used. Polarity of the disturbed electrode is defined by the potentiometer connections. In A, the negative electrode was disturbed; in B, C, and D, the positive electrode was disturbed. Note that the artifacts are directed in sign opposite to that of the disturbed electrode. This as well as the severity of the artifacts depends on metal type; a steel electrode produced an opposite result. Electrode polarity orientation when implanted can therefore help differentiate between R-waves and movement artifacts. Large pieces of copper, silver, silver-silver chloride, and aluminum exhibited polarity changes similar to stainless steel. The half cell of stainless steel was positive to all of these metals; aluminum was most negative. Magnitudes of artifacts were least from silver and silver-silver chloride, but again, their use as for chronic implant is not recommended. A few of the more exotic electrode metals or materials might be preferred. However, comparative tests of electrodes should be based on an emphasis on resistance to perturbation as well as on rate of recovery, and on tissue response and physical shape that includes lead connections in order to relate theory to practice.

The records in figures 4 and 5 show that at least an order of magnitude of difference in the susceptibility to produce major spike-like disturbance artifacts can be noted under either of the in vivo or in vitro conditions. Even though the disc, by virtue of a larger area, should have a somewhat lower impedance, the impedance of the lead extension with a calculated peripheral area in excess of 10 mm² would not be expected to be high (ref. 24). But the induced variance in half cell potential is obviously high and occurs sharply for the lead extension when under nonstationary conditions. Even the use of a 10-Mohm input impedance probe in the in vitro tests was not adequate to counter this difference.

Aside from the structural suitability for an implant, some of the advantages of the disc seem to derive from the fact that the design widely and evenly distributes current flux and bridges large areas of tissue. Localized regions of either disturbance or cellular activity therefore would not dominate the entire electrode's behavior as would be the case with a small structure. On the other hand, large size would not diminish the ECG signal as expected if the biopotential were localized. Again, the ECG is generated throughout the body because the heart behaves as an electrical syncytium. Polarized and depolarized regions are created over a substantial structural distance. Even a large electrode cannot easily traverse that distance and thus tend to minimize its own net potential change relative to a distantly located reference electrode.

A plurality of electrodes or a flattened tube that is open at one end and insulated on the outside are alternative suggestions. A tube would increase the distance from surrounding tissue and tend to isolate the electrode interface from physical movements against tissue. A plurality of electrodes would further distribute current flux and may offer some advantage for minimizing amplitude fluctuations in R-waves as the heart's electrical axis changes. Maximum amplitudes, however, might be reduced because of the net potential difference across the separated parts of an individual electrode. These suggestions are secondary options, the implementation of which increases the procedural complexity; they may not be necessary. Also, flexible stainless steel mesh cloth of large area has been tried but was found unsuitable because of problems with lead connections and suture locations that seem to produce spikes. Also, the base potential difference produced by rubbing the mesh cloth when in vitro was substantially greater than that for the disc, but the spikes produced this way were about the same. A small disc has been routinely used for small animals and has been illustrated elsewhere (ref. 25). For example, good quality records can be obtained from rats running on a treadmill; a larger disc is better if animal size and skin thickness for revascularization after implant permits.

RF Interference

Problems of RF noise interference and signal strength variations can, of course, cause difficulties with reception. At the implant to collar relay interface, a crystal-controlled, commercial, tracking transmitter was

used. The transmitter was modified so as to be a complete slave to the output of the collar receiver and its associated logic circuitry. The logic circuitry delays the incoming pulse characteristics and then regenerates them for retransmission. Thus, the strong retransmitted RF cannot normally interfere with reception from the implant. The pulse width and intervals are maintained through the relay but the RF is changed to that of the retransmitter. The RF of both the implant and the collar transmitter are selected to be nonharmonic to reduce possible interaction. This separation is also convenient for experimental reasons. The use of different receiver bands is helpful in any new experiment to check coupling requirements between implant and collar. During experiments, the distance between the animal and the investigator's receiver will vary. When that distance is short, interference could occur if both transmitters had a similar frequency.

Because the implant produces a relatively strong RF signal, variations in signal strength are less troublesome when an attempt is made to achieve a good coupling with the collar receiver as the animal moves and changes body positions. Also, the collar receiver sensitivity can be minimal and less susceptible to extraneous RF interference. A wider receiver bandwidth is more feasible, and the power requirements are reduced in that a passive or only a slightly active gain need be employed. Thus, the size and weight of the external collar is not greatly increased over that required for the basic tracking condition.

The similar kinds of noise problems that occur at the output of the investigator's receiver are dealt with in the demodulation interface circuit in three basic ways. First, sharp band-pass filtering selects the tone burst generated by the incoming RF. Second, the RF sensitivity gain of the receiver is coupled to threshold detection; this involves a combination of manually set and autotracking modes to accommodate signal strength variations. Third, since much of the remaining extraneous RF noise involves short random pulses, pulse width discrimination of the received signals is used to block this noise and to sort the heart rate from the temperature pulses.

The tone bursts will not always be perfectly formed, particularly when near the limits of range; that is, the individual sine waves may be amplitude-modulated. A conversion to a square wave for pulse width discrimination is used and the top of the square wave is sustained for a brief period to stretch past a temporary attenuation. This period of pulse stretching must be short, however, so that only severe random noise could produce an output that is long enough to be accepted as a heartbeat.

Packaging and Implant Procedures

Some comments and suggestions about packaging and surgical implantation procedures follow. The units should be hermetically sealed with appropriate headers, such as glass to metal, for lead passage out of the unit in order to prevent moisture penetration. The outer coat of the unit must be tissue compatible — silicone RTV can be used. Tissue, however, does not adhere to

RTV and a layer of Dacron coarse-weave cloth will facilitate tissue imbedding. This is strongly advised so that the unit can become firmly anchored within the body where it was originally sutured. When the implant is abdominal, some Dacron should be added to the leads where they will pass through the muscle wall to run subcutaneously. Appropriate sutures should be taken in that region to prevent slippage, to promote healing and reclosure of the abdominal cavity, and to prevent lead flexure at that point from pressing outward against the skin. Revascularization of the overlying skin might otherwise be inhibited.

Sensors located subcutaneously should be placed to the side of the skin incision to facilitate revascularization of the skin. All such objects should be sutured in place rather than left to float, in which case they may be more easily rejected or change location. The electrodes in particular must be well sutured for stability. An appropriate amount of lead slack is necessary so that sensors will not be stressed when the animal extends its body. Flexure stress at the lead/sensor junction is minimized also if the lead path into the sensor is not curved. Again, in no case should the leads or sensors exert an outward pressure against the overlying skin; even if healing occurs initially, a constant outward pressure to the skin may later cause rejection. A conservatively placed suture will usually alleviate problems of pressure from lead flexure and help to guide the lead path. Tight sutures around the leads or sharp angles, of course, cannot be tolerated. The job of channeling subcutaneously is not difficult, even in fairly large animals if appropriate tools are used (ref. 26).

A good flexible lead can be made with multistrand stainless steel wire, silicone tubing, and self-leveling silicone RTV. In some cases, it is adequate simply to insert the wire into a section of tubing and then inject the tube with the RTV. Greater flexibility can be achieved by coiling the wire within the tube. This can be done by coiling the wire around a piece of small-diameter metal tubing which is then inserted into the silicone tubing. The metal tube is then withdrawn. If necessary, the silicone tube can be temporarily expanded by soaking it in xylene; the xylene later evaporates and the silicone shrinks approximately to its original shape.

The common practice of using solder and solder flux to make connections to leads can cause problems. Tissue toxicity responses and the deterioration of the connection due to the battery potentials that arise from the metal discontinuities and due to the flux chemistry are likely. Spot welding, bolting, and crimping are better ways of making connections. Coating these connections, with RTV, for example, adds protection, reduces flexure stress, and offers an increased impedance boundary against electrochemical potentials.

The use of gas sterilization techniques, for example, with ethylene oxide, is recommended. The gas penetrates the outer potting materials. Zephiran chloride can then be used as a surface cleaning agent during implantation to reduce the possibility of contamination. Because heat and pressure are often used with gas sterilization, care should be taken to avoid damage to the potting materials or to the transmitter unit.

After the implant, closure of the skin might best be done with steel or a monofilament suture. Silk can act as a wick that might promote infection. It is best to use permanent sutures for the implant and for abdominal closure, however, rather than absorbable sutures. Antibiotics should be generously used, and their direct application to the implant and surgical area seems helpful in preventing initial infection problems. During surgery, skin separation from the underlying tissue should be kept to a minimum; the loss of vascularization promotes subsequent edema and results in cold regions that inhibit rapid healing. It is recommended that the animal's fur be shaved sparingly and that a temporary bandage be applied for support and warmth (the bandage should still allow exposure to the air). Talcum powder along with the topical antiseptic helps to keep the area dry. Of course, animal behavior after surgery and within the experimental situation influences procedures. An implant under field conditions should be done only after these things are known, particularly if the animal is to be released immediately without a day or two of confinement for purposes of observation.

IMPLANTABLE TRANSMITTER CIRCUITRY

Figure 6 is a block diagram of the implantable transmitter; figure 7 shows the entire circuit design. The major functional stages are indicated by capital letters to correspond with waveform outputs of these stages as shown in figures 8 and 9.

The RF bypassed input voltages to the R-wave detector stage are first limited by a voltage follower whose "slew rate" is set at ± 1 mV/msec (fig. 6) (A). This allows normal excursions of the QRS complex while greatly reducing the magnitude of large-amplitude, sharp signals which might drive the filter and amplifier circuitry into distortion (refs. 27,28). The next stage is a six-pole, low-pass filter (ref. 29). It provides a 36 dB per octave rolloff with a 3 dB point (70% amplitude) at 31 Hz (B). Its output is connected to a two-pole, high-pass filter with a 3 dB point at 18 Hz and a rolloff of 12 dB per octave (C). This filter circuitry provides a band-pass centered near 26 Hz with a sharp rolloff at higher frequencies and a lesser rolloff at lower frequencies. These filter characteristics select the fundamental frequency component of the R-wave while greatly attenuating other components. An AC coupled amplifier with a gain of 56 is next (D). Gain was set to accommodate ECG amplitudes within a range of ± 5 mV. A precision full-wave rectifier converts the amplifier's output to an absolute value so that all signals are then positive regardless of the polarity of the input signal (E). Total gain is reduced to unity during RF transmission as a further precaution against spurious responses; this circuit is indicated later.

The remaining circuitry generates a constant-amplitude, 5-msec-wide pulse each time an R-wave occurs. It does this by identifying the highest peak in the rectified and filtered QRS complex by means of a peak pulse detector (ref. 30). The detector follows the amplitude envelope of the

rectified QRS complex and stores the maximum level on a capacitor (C). As long as the input signal is positive-going and greater than the stored charge, this stage (F) functions as a voltage follower. When the input waveform reaches a point of inflection and starts negative, the stored charge back-biases the diode decoupling the negative feedback loop. With the feedback loop decoupled, the stage functions as a comparator. Thus, the output swings into negative saturation since the inverting input is more positive than the noninverting input. If subsequent peaks do not exceed the stored charge, the output remains locked in negative saturation. Thereby, the last negative output transition occurs at the highest peak of a pulse complex.

The detector's output is connected to a biased CMOS line driver whose output (H) controls a retriggerable monostable device. Unless retriggered, the monostable resets in 110 msec. But in the case where the peak detector is responding to a cluster of pulses with intervals less than 110 msec, the monostable may be retriggered several times, not resetting until 110 msec from the detection of the highest pulse. The reset (J) drives a second, nonretriggerable monostable with a time constant of 5 msec. Thus, a 5-msec-wide pulse is generated (K) for each detected R-wave. That pulse triggers the crystal-controlled RF oscillator (S) via the combination of gate control circuitry (Q,R). The fixed delay of 110 msec does not affect the beat-to-beat measurement of heart rates less than 545 BPM. But this delay effectively is increased by a period selected in the gain control circuitry that leads back to the amplifier and rectifier (D,E). For example, the addition of 20 msec through that circuitry yields a rate limit of 461 BPM.

The 5-msec pulse (K) also provides a reset control for the peak pulse detector. Reset is done by closing a normally open gate for 5 msec, discharging the capacitor on the detector (C). The level of charge left after the switch reopens is a function of RC values (G,I) and of the 5 msec. For example, a discharge voltage of half the previous peak amplitude allows the detector to track, on a beat-to-beat basis, changes in R-wave amplitude of 2 to 1. Thereby, the detector's threshold is automatically adjusted to provide a trigger level which is proportional by a desired amount to each measured R-wave amplitude. A resistive bridge in the discharge path of the detector sets the absolute minimum threshold level to ± 0.3 mV and lower referred to the transmitter's ECG input. This ensures that the detector will not trigger on baseline noise when an adequate ECG is not present.

A restart circuit is provided in the event that the detector is driven into positive saturation such that the charge on the capacitor might remain higher than the subsequent incoming R-waves. In this condition, no triggering would occur to automatically adjust the threshold level. The restart circuit, which allows the capacitor to discharge until it re-acquires the R-wave, activates 1 sec after the last detected heartbeat. The 1-sec delay is related arbitrarily to the expected lower heart rates. With a 1-sec value, the search mode would be employed at all beat-to-beat intervals of rates less than 60 BPM. For many animals, this may be a resting state when artifacts from EMG and electrode movements are least

expected, except in such special physiological conditions as diving bradycardia.

The restart circuit itself consists of a resistor and capacitor connected across the battery supply. When the charge on this timing capacitor approaches V_{dd} , a gate connected to it closes. The detector's storage capacitor (G) is now discharged through the gate via resistor to ground. The resistor determines the search rate as the threshold lowers to its absolute minimum. The RC combination (L) that controls the gate provides the delay between the last heartbeat and the start of the search mode. Another gate is connected to the timing capacitor so that the search mode can be canceled. When closed, it discharges the timing capacitor to V_{ss} . This gate is closed each time the detector (F) indicates a new pulse has been received. The search mode, therefore, is never employed at heart rates greater than the delay time, as seen in figure 8.

Besides keying the RF oscillator and adjusting the threshold on the peak detector, the 5-msec pulse generated by each heart beat initiates a counter divider chain and signal control to allow sampling of two temperatures periodically. The circuit diagram is included in figure 7. The significant waveforms are shown in figure 9. The R-wave pulse is divided by 50 using two CD 4017 decade counter dividers. A reset pulse (M) every 50 counts initializes the second CD 4017 and starts a third CD 4017 (O). The clock for the third counter (pin 14) is a multivibrator oscillator and has its period controlled by a resistance bridge. Four independent bridge circuits are provided, two with thermistors and two with the fixed resistors that provide a 0° C and a 50° C calibration. The four bridges are sampled sequentially by four CD 4066 switches controlled by the CD 4017 that advances one step following each pulse.

The oscillator operates as follows: A D30A3 is used as a constant current source to charge a 1- μ F timing capacitor with the current-level variable proportioned to the voltage level derived from the resistance (thermistor) bridges (T). An NPN D26E1 emitter follower is used to compensate the emitter-base diode voltage of the D30A3. With the constant current from the D30A3 charging the 1- μ F capacitor, a linear voltage ramp is generated starting at V_{ss} . The ramp signal is connected to the negative terminal of the L161 comparator and the positive side is connected to the L161 output by a 2-to-1 attenuator. With the ramp signal below the positive terminal voltage, the L161 output is saturated at V_{dd} , and the 2-to-1 divider places a 0 voltage at the positive terminal. As soon as the ramp crosses this 0-V threshold the L161 comparator switches to an output of V_{ss} and the positive terminal is also V_{ss} . The L161 holds the V_{ss} level until the 1- μ F capacitor is discharged and then the entire cycle starts over again with the charge current from the D30A3. The ramp signal is operated between V_{ss} and 0 since the L161 allows operation of the inputs all the way to the negative rail; but with a V_{ss} to V_{dd} supply of 2.7 to 3.0 V, it will not work with a common mode voltage closer than 1 V to the V_{dd} rail. This ramp generator voltage range also provides the necessary collector voltage for the D30A3. The reset after each ramp period (proportional to the bridge voltage) is accomplished with a CD 4066 switch which is connected to the L161 output via

a CD 4001 inverter. The return reset cycle is very short because of the low impedance in the switch. By adding a 3.3 kohm thermistor in series with the switch the reset period can be adjusted to 10 msec for the pulse width for transmitting temperature data (N). The enable circuit (P,Q) allows a time delay to capture the duration of the last temperature pulse and, in combination with the gain shutdown control (Q,D), ensures that a heartbeat 5-msec pulse will not overlap with that temperature pulse.

A number of considerations suggested that a thermistor bridge circuit would be more satisfactory than a direct resistor charging circuit for the timing RC. Since at least one of the thermistors and possibly both would be located remote from the electronic package, it was desirable and probably essential to use a low impedance thermistor. For instance, whether a 30-kohm or a 3-kohm thermistor is needed depends on the adequacy of moisture protection, and that is difficult to evaluate; therefore, the lower the thermistor value, the better the chance of maintaining consistent results. A 3-kohm thermistor at 25° C is about 10 kohms at 0° C (lower temperature extreme). For a 0.1° C temperature accuracy, a 0.04% resistance accuracy is required so that a shunt impedance of 2 Mohms across the thermistor would cause a 0.1° C error. A 20-Mohm shunt would give the same effect on a 30-kohm thermistor. This indicates that even with low-impedance thermistors, careful protection from moisture is essential.

If low-impedance thermistors (most desirable because of moisture problems) are used directly in RC timing circuits, two other problems occur. One is the switch impedance of the CD 4066 which is of the order of a few hundred ohms and deteriorates rapidly as the power source is reduced from 5 V to 3.0 V. This could represent a substantial impedance in series with the thermistor. Any significant variation in this impedance is likely to cause data errors. Because about 1 sec is allocated to retrieve the temperature data, very large capacitors would be required to obtain a suitable time constant with low impedance devices. Both of these problems can be circumvented by using a resistance bridge.

A D30A3 is used as a switch to power the four resistance bridges only when the approximate 1-sec temperature data are taken. The D30A3 is driven by a D26E1 so that the D30A3 can be properly saturated without loading the CD 4017 output. With the base current levels used, the voltage drop across the switch is typically 10 mV. Even this low voltage drop would cause readout errors if a bridge circuit were not used. Since all the bridge circuits (four each) are turned on with a common switch (D30A3), whatever voltage drop occurs in the switch is corrected for by the 0° C and 50° C calibration readings.

Minimizing the total power consumption is important to achieve an operational life of more than 1 year with a modest-sized battery. Although the CMOS devices are on continuously, they require very minute currents except during the short microsecond transitions between on and off states. The low-impedance thermistors would, however, represent a drain of many milliamperes if they were on all the time. Since the temperature is only sampled for 1 sec every 50 heartbeats, assuming an average heart rate of

100 BPM, this gives a duty cycle of 1 sec "on" and 30 sec "off." With typical thermistor values of 3 kohms and bridge resistors of 3 kohms, the "on" current for the four bridges is 2 mA; the average is 1/30 of 2 mA or about 60 μ A. Switching each of the four bridges independently, which could further reduce the average current, did not seem advisable because extra parts would have been required and because of the possibility of error introduced by impedance variations in different switches.

Figure 10 shows a typical thermistor resistance vs temperature plot as well as various thermistor resistance bridge combinations. The tabled values were obtained with a breadboard bridge circuit and substitution of resistance to simulate thermistor impedances. Over the 0° to 50° C desired operating range, the thermistor changes about 10 to 1 in resistance and also is a nonlinear curve. Although a 3-kohm thermistor has been used for the data of figure 10, the shape of the curve would only change very slightly with a thermistor of a different impedance. The use of various bridge configurations results in a variety of possible curves. Limitations in the timing accuracy that can be transmitted within a limited RF bandwidth and using about a 1-sec interval for all temperature readings indicate that the raw thermistor 10-to-1 dynamic range is too large for proper use in this system. The approximately 3-to-1 range for the bridge curves seems about the best. A 1-kohm resistor is placed in series with the thermistor side of the bridge so that if the thermistor resistance were to short-circuit, the oscillator period would not be infinite. Such safeguards must be made in case a shorted or open thermistor lead causes the entire system to otherwise shut down. The bridge circuit plus some series resistance with the thermistors prevents such a failure and also yields identification intervals of such mishaps.

Some further manipulation of the bridge arrangement or resistance values could probably improve the dynamic range. This involves some sacrifice of the linearity but linearization can be done more easily through the demodulator. Calibration curves for the thermistor bridge in the transmitter circuit and with a 30 kohm thermistor are shown in figure 11.

As shown in figures 7 and 9, the temperature circuitry controls gating (Q) and (R) to the RF oscillator's input (S) and to the control circuitry to the amplifier gain (D). During a temperature measuring cycle, the 5-msec heart-rate pulses are replaced by the 10-msec temperature pulses, thereby doubling the oscillator's on-time. The R-wave counter nevertheless continues to advance so that the start of each temperature cycle represents the 50th heart beat exactly; only the dynamic beat-to-beat variation is interrupted temporarily.

The single stage RF oscillator is base-emitter tuned with a third-overtone crystal employed as the frequency determining device. The base-emitter circuit operates at the crystal's third harmonic of 54 MHz. The collector circuit is also tuned to 54 MHz. This configuration provides good frequency stability in a single-stage oscillator because the output load is effectively isolated from the base-emitter tuning loop. The oscillator's output is connected to the thermistor leads. These leads serve as the

antenna, thereby optionally eliminating the need for a separate antenna. Bypassing RF is provided at the resistance bridge as well as at the ECG input and battery supply. The oscillator is keyed "on" and "off" by the ECG and temperature pulses so that it is active only during each pulse period. Turn-on time to full RF amplitude is within a few cycles of the 54-MHz operating frequency. Thus, the resulting wavefront slope is less than 20- μ sec wide compared to the data pulse intervals of over 100 msec. Peak RF output power is about 8 MW.

The system uses two center-tapped mercury cells to provide ± 1.4 V. Power consumption is the sum of the continuous current drain of the circuit plus the average peak current, which is heart-rate dependent. At a heart rate of 100 BPM, the average current drain is about 350 μ A, of which approximately 250 μ A is continuous.

Figure 12 shows the transmitter at various stages of prototype packaging for implantation and testing. The prototype unit was fabricated with discrete parts and integrated circuits. A further reduction in size would be possible using hybrid construction techniques, since the active components used are available in chip form. The battery shown has a 2400-mAhr capacity, thereby providing a maximum operating life of about 9 months at an average heart rate of 100 BPM.

The AM receiver used with this transmitter operates at 54 MHz, with an output frequency response from 0 to 10 KHz. The low-frequency capability is important since the received pulses can have durations as long as 10 msec. The amplitude is adjusted to provide the 0 to +5 V pulse heights necessary for driving the demodulator.

RETRANSMITTER COLLAR CIRCUITRY

The retransmitter consists of an RF receiver, logic circuitry, and a commercially available animal tracking transmitter, all packaged within a collar. Figure 13 shows a prototype collar and field receiver equipment for a dog. Dimensions of the electronics package are 5 by 5 by 7 cm; weight is 320 g. Most of the size and weight is due to the tracking transmitter, which is 3 by 5 by 7 cm and weighs 277 g. The transmitting and receiving antennas are incorporated within the collar.

Figure 14 is a circuit diagram of the retransmitter; a circuit timing diagram is provided in figure 15 (the labeling with capital letters start over). At the input (A) of the circuitry there is a passive RF receiver consisting of two tuning stages and a hot carrier diode detector. The stages are tuned for a bandwidth of about 8 MHz with a center frequency at 54 MHz. The receiving antenna is a flexible lead configured within the collar strap. Figure 16 shows the arrangement of the antenna lead. As can be seen, the lead begins and ends at the electronics package, with maximum extension to the collar's tip. The outgoing and return paths are separated for the width of the collar. Following the tuning stages, the hot carrier

diode circuit detects the negative envelope of the incoming RF pulse (B). This detection provides an audio frequency pulse which is amplified (C) and then reshaped by a comparator (D). Receiver sensitivity is adjusted by raising or lowering the comparator's threshold level. When practical, this adjustment is made with the collar on the animal. Otherwise, it is done prior to use by estimating the expected field strength and background noise for the particular application. Figure 17 shows an alternate receiver with a single stage of RF gain. This active receiver is used in the event that signal transmission from within the animal is exceedingly weak. This occurred during testing because of an antenna break. Variations in gain requirements can be expected for procedural reasons and size limitations among animals. The active receiver requires a greater current drain to operate, about 700 μ A compared to less than 5 μ A for the passive receiver. The antenna in either case is the same. The stage of RF gain in the active receiver causes a polarity reversal at the input to the comparator. This is easily remedied by interchanging the comparator's inputs.

The comparator drives the CMOS logic circuits which in turn generate a control pulse for actuating the RF tracking transmitter. The control pulses are delayed from the incoming receiver pulses, yet keep the same width and interval as received. The delay prevents interference of the strong retransmitted RF pulse with the reception of the weaker RF signal from the implanted transmitter.

To generate the delayed pulse train, the output of the comparator (D) is connected in parallel to the inputs of a pair of monostable devices. One monostable triggers on the leading edge of the incoming pulse, the other on the trailing edge. Each provides a 20-msec-duration pulse which is complementary to the other. These outputs (E,F) operate a pair of gates (G) that activates the transmitter (H) when both are closed. As seen in figure 15, the delay and pulse width of the RF retransmission are the result of subtracting the outputs of the two monostables by means of the control gates. Receiver squelch during the RF retransmission is done by a blanking gate (I) at the inputs to both monostable devices. This gate closes (F) to (I) before the retransmitted RF pulse and remains closed for about 100 msec. This insures that the retransmitter will not be self-triggered during that time and allows the receiver circuit a recovery time after each transmitted pulse. The blanking gate is controlled by a circuit which stretches the pulse output from the trailing-edge-triggered monostable. Because the collar was relatively insensitive to RF noise, it did not seem necessary to include circuitry to prevent the occurrence of a noise spike from triggering the monostable device. If that did occur however, the receiver would not accept another pulse for a period of about 120 msec; the occurrence of a heartbeat or temperature pulse could then actually be missed within that period. Initial pulse width discrimination in the logic circuitry could, however, be done with little added cost in terms of size or power requirements.

The tracking transmitter is a Telonic's Model MK-3A-TA-4 (fig. 13) with a factory-modified input. That is, the standard internal control of the RF pulse rate is omitted with control brought instead to a pair of

external inputs. The companion receiver provided by Telonics is a hand-held model designed for field use. The receiver is crystal-controlled, as is the transmitter, and operates within the RF spectrum normally utilized in animal-tracking work. In this case, a frequency of 148 MHz is used. The output of the receiver is a tone burst applied to either a self-contained speaker or a headset. The duration of the nominal 2 kHz tone is determined by the width of the incoming RF pulse, in this instance either 5 or 10 msec. The tone burst is retained, rather than modifying the receiver to obtain a standard pulse, because it is readily recorded without distortion on a hand-held cassette tape recorder. Also, since the operator must adjust the receiver's output in the field without benefit of an oscilloscope, the tone is easily recognized using only the headset or speaker.

RECEIVER DEMODULATOR INTERFACE CIRCUITRY

Once a field recording has been made, the magnetic tape is brought to the laboratory where it is replayed through a circuit that converts the tone bursts back to rectangular pulses compatible with the demodulator's input. Figure 18 is a diagram of the interface circuit. At the circuit's input is a band-pass filter (ref. 29). It is centered at 2 kHz, which is the receiver's output tone. A peak detector and a comparator then convert the sinusoidal waves within each tone burst into a group of rectangular pulses. The peak detector provides an adaptive threshold level for the comparator. Controls mounted on the front panel of the unit allow selection of automatic tracking rates and triggering amplitudes for the adaptive threshold. In addition, a fixed threshold level can be selected.

After the sinusoidal pulses have been changed into rectangular shapes, they are further filtered by means of a digital band-pass filter centered at 1.8 kHz. The filtered rectangular pulses are applied to a digital envelope detector which converts each group into a single pulse with a width of either 5 or 10 msec, as determined by the original transmission (ref. 31). The envelope detector can be adjusted to bridge across a single, missing pulse within a group. This allows the envelope to remain unchanged in the event that the comparator misses a single, sinusoidal pulse within a tone burst. This could result from an instantaneous amplitude fluctuation to which the adaptive threshold could not respond. These single pulse-to-pulse amplitude variations result from superimposed noise or quick changes in RF signal strength. Adjustment of the bridge duration is done by altering the time constant of R_3C_3 .

Additional noise rejection is provided by a circuit which sorts out envelopes with less than 3-msec periods while passing those of greater periods, such as the 5 and 10-msec data pulses. Thus, single, spurious pulses within the 2 kHz band-pass are eliminated. Pulse rejection is determined by the time constant of R_4C_4 .

The output of the interface circuit uses two voltage followers (E). One drives a lamp mounted on the front panel which indicates acquisition of

data pulses. The other provides pulse height of the proper amplitude for driving the demodulator.

Front panel controls, besides allowing for selection of threshold functions, also allow the selection of frequency band passes in the event that the receiver has an output tone other than the nominal 2 kHz. This flexibility allows the recorded data to be retrieved according to the experimental conditions in the field or laboratory. As an example, data recorded in the field from a fast moving animal, with resulting RF signal strength fluctuations, would be handled differently from data recorded from a resting animal with nearly steady-state signal reception.

The interface circuit is low powered and can be operated either with batteries or a direct current power supply.

DEMODULATOR CIRCUITRY

The microprocessor-based demodulator is used to accurately determine the time interval between pulses from the telemetry receiver output. It discriminates against unwanted noise and performs heart rate and temperature calculations based on the time-interval information.

To accomplish the accurate timing, a 2 MHz clock signal (ϕ_2) used to generate basic timing operations inherent to the microprocessor is divided down to a 1 kHz signal (1-msec interval).

Figure 19 is a top view of the demodulator showing the internal component layout consisting of a central processing unit card (CPU), D/A output ports and converters; 1K RAM/2K ROM card and a front panel/interval timer/interrupt generator, card. All microprocessor signals use the S100 bus system as a common element for communicating between the peripherals and the CPU card. The S100 bus provides, at a low cost, a variety of peripheral interfaces popular among the home computer hobbyists that are easily available at any local computer store (ref. 32).

A detailed description of the circuit operation of the demodulator follows.

The output of the telemetry receiver and interface circuit (fig. 20 pin J64) is buffered by IC 21 and fed to a positive and a negative edge triggered "D" type flip-flop (IC 5, pins 3 and 11). Their negative true outputs are connected to an eight-bit priority decoder (IC 6, pins 1 and 2).

The highest level of priority is pin 3 of IC 6. This input is reserved for a 1-msec timing interval generated by decade counters IC 2, 3, 4 and a divide by two flip-flop IC 1. The negative-going edge detector signal (IC 6, pin 1) has the next highest priority. The positive-going telemetered signal (IC 6, pin 2) is the lowest priority request.

When an input signal level change or a 1-msec interval occurs, the priority decoder generates an interrupt signal to the microprocessor (IC 6, pin 15). The interrupt signal causes the microprocessor to stop processing and to execute a vectored interrupt-service routine. A detailed description of the software routines is included in the appendix. Using the continuator to the service routine, the CPU (microprocessor central processing unit) reads either the time interval, R wave to R wave timing, or temperature cycle data. It then processes it and returns to the interrupted task.

The CPU acknowledges the interrupt request by sending an interrupt acknowledge signal, IRACK (ref. 33). The IRACK signal is used to clear the "D" type latch holding the interrupt request. It also allows the lower priority requests (if any) to be serviced in the same manner.

Figure 21 shows the view of the demodulator front panel for entering the command modes in the operation or calibration of the demodulator and displaying the real-time data. The switches are sensed by input port No. 7 to the 8080 card (fig. 22, IC 14, pin 8 and IC 15, pins 3 and 5).

The microprocessor reads the input instruction immediately after the power is "ON" or at any time the RESET key is depressed in the front panel. The RESET switch is connected to the CPU RST line and causes the displays to be initialized to zero, clears all memory, resets the time interval, clears all the interrupt latches and initializes the microprocessor program counter (internal to the CPU) to location zero. The calibration level (HI or LO) is read as an input when the software branches to the internal calibration routines.

Data to the front panel LED display is gated by the action of a demultiplexer (IC 13) and the output instruction status line IC 13, pin 6. The data, in BCD form, is latched to the LED displays by the six enable lines from the demultiplexer and held until a new reading is made.

The analog outputs are generated by three 12-bit D/A converters that require one's complement BCD data. The software complements the data and transfers the first 8 bits to two quad D type flip flops. All 12 bits are presented to the digital to analog converters when the software outputs the last 4 inverted bits to a quad D type flip flop and an 8212 is enabled, latching the 8 bits stored in the two 74LS175 latches.

The output of the converters are buffered and connected to the three analog output lines on the back of the demodulator.

RESULTS AND DISCUSSION

The prototype of this system was tested on a dog. Preliminary tests were made with a transmitter breadboard mounted in a backpack worn by the animal. A standard ECG transmitter was also placed in the backpack. Two ECG electrodes were implanted subcutaneously with the leads brought out to the

backpack where they were connected to both transmitters via an RF isolation junction. Chart paper recordings were then made while the dog was exercised within the range of the transmitters or on a treadmill. The recordings allowed the heartbeat pulses, derived from the new system, to be compared directly with the clearly identifiable ECG waveform. Results were positive with only an occasional heartbeat pulse being lost by the new system during periods of heavy exercise. ECG recorded during the same sequence of exercise showed R-wave amplitude fluctuations of $\pm 35\%$ on a beat-to-beat basis. The triggering threshold of the R-wave detector had been set for a tracking rate that would accommodate amplitude changes of less than this and seemed to account for the occasionally missing beat. A nominal tracking rate of 40 to 50% of R-wave peak should alleviate the problem. Signal artifacts occasionally occur also, but appeared to be due to movements of the external leads and connections rather than to the electrodes.

Next, the packaged transmitter was implanted in an 18-kg dog. Two ECG electrodes and one thermistor were attached subcutaneously. Another thermistor was located near the liver for measurement of deep body temperature. After 1 week, tests with the dog in a kennel were begun. The RF signal from the implanted transmitter was received, without retransmission, using a standard AM receiver. The output pulses were applied directly to the demodulator. The three analog outputs of the demodulator and the pulse train from the receiver's output were recorded on chart paper. This allowed the heart rate, on a beat-to-beat basis, and the two body temperatures to be correlated with the transmitted pulse train. Several recordings were made, the longest being 24 hr. The demodulator and receiver maintained lock during all recording sessions, as indicated by the analog outputs which followed the pulse train without dropout.

Tests of the retransmitter collar were made next with the dog still in the kennel. In this instance, the retransmitted pulses were compared to the directly transmitted pulses. This was done by recording the outputs from each system on a chart recorder. But this time the demodulator was driven by the RF transmission link. Again, the three analog outputs were recorded for correlation with the two pulse trains, representing the direct and indirect transmissions. The retransmitted RF signal proved to be intermittent. Also, one temperature channel was in a continuous state of saturation. (Later investigation showed that a thermistor lead had broken.) Since the thermistor leads also serve as the transmitting antenna for the implanted unit, RF field-strength measurements were made to determine the effect of the broken lead. The RF pulses from within the animal were very weak at the normal operating frequency of 54 MHz. The first harmonic at 108 MHz was nearly 20 dB stronger, but still weak. Therefore, the receiver in the collar was returned to the stronger 108 MHz signal and a single stage of RF amplification added. The previous tests were repeated. This time the retransmitter collar locked onto the pulses from the implanted transmitter with no loss in data.

Next, both the retransmitter and the implanted transmitter were tested for maximum range. As can be seen in figure 21, the test site was located in a heavily industrialized area with numerous power lines and metal

buildings nearby. In A, the view is over a salt marsh toward the receiving station which was a metal building indicated by the arrow; the distance is 1 km. In B, the view is in the opposite direction which shows the instrumented dog and the investigator within a fenced ranging area. The implanted unit had a range of about 12 m. The AM receiver had an output bandwidth of 10 kHz and a sensitivity of 1 μ V. The antenna, which was mounted on a 3-m mast, provided a gain of 6.5 dB. Because the transmitter, with its broken antenna lead, was operating in a greatly impeded mode, an estimate of maximum range was made. This estimate for the improved range was based on a previous comparison of the measured field strength at the normal operating frequency of 54 MHz, with that of the 108 MHz harmonic. This measurement, made with the transmitter placed within saline filled bags, showed the 54 MHz fundamental to be 42 dB greater than the 108 MHz harmonic. Additionally, simulated heart rate was transmitted successfully under these conditions over a distance of 175 m using the 54 MHz operating frequency and with receiver and antenna characteristics similar to those used in the later tests in which the lead was broken. These indications suggest that the range of a properly operating transmitter should be about 150 m. Improvement to a useful range greater than 200 m should be possible in an ideal, rural environment, particularly if a higher gain receiving antenna were used.

Range tests of the retransmitting system were conducted within the same industrialized location. The retransmission system included the collar-mounted retransmitter, tracking receiver, cassette recorder, and interface unit. The receiver was located in a large one-story metal building with the antenna mounted on a 4-m mast placed on the roof. Total height above ground was 9 m. This antenna provided a gain of 14.5 dB. As before, a chart recorder was used to provide real-time measurement of heart rate and body temperatures using the demodulator's analog outputs. However, the tracking receiver, with its tone-burst output, drove the demodulator via the interface circuit. Again, the transmitted pulse train was recorded on one of the chart recorder channels. In addition to these real-time recordings, the receiver's output, along with voice commentary, was recorded on magnetic tape for subsequent analysis in the laboratory. Included were data taken while the dog was field-exercised on a leash. Two-way voice communications between the investigator in the field and the operator in the station were maintained during these tests. Next, the dog was placed within a chain-link fenced enclosure 1 km from the receiving station (fig. 21(b)). While in the 2-acre enclosure, the dog was allowed to roam about freely. Visual observation was maintained using a telescope. Finally, with the dog still in the enclosure, the receiver and a hand-held antenna (fig. 13) were taken to various remote locations to simulate tracking conditions.

These tests indicated that it was possible to retrieve data with a signal-to-noise ratio of unity at the receiver's output as viewed on an oscilloscope. This corresponds to the conditions present at about 80% or greater of the maximum tracking range. At this distance, the operator begins to experience problems hearing a tone distinct enough from background noise to allow effective tracking. The tracking system used was indicated by the manufacturer to have ground-to-ground tracking capability up to 18 km under ideal geographical conditions. Thus, the modified system

should provide some physiological data at a distance perhaps as much as 14 km, but many things would limit that capability substantially.

Analysis of the accuracy of the temperature data gave a result closer to $\pm 0.3^{\circ}$ C rather than the desired $\pm 0.1^{\circ}$ C. This was not accounted for in the transmission link, since the intervals of the temperature pulses could be resolved repeatedly within 200 μ sec. The minimum pulse interval, representing 0° C, was 176 msec. Additionally, the temperature data are scanned within a second or so at each reading, including the high- and low-temperature calibrations. Thus, the resolution of the RF-transmission link, plus the continuous updating for drift during the temperature scan, should provide the desired $\pm 0.1^{\circ}$ C accuracy during the life of the unit (an unknown being the effects of moisture on the thermistors). However, at the time of these tests, the demodulator was set up to resolve increments of 1 msec, which does not provide the required resolution. More resolution can be had by extending the intervals at the transmitting end, or by increasing the resolution within the demodulator itself. Increasing the transmitted intervals would of course enhance the RF link, but at the expense of interrupting more of the beat-to-beat heart rate. On the other hand, the demodulator could be changed to provide the added resolution without changing the data format. The temperature cycle could be less frequent also. As indicated before, the system has sufficient flexibility within its basic design to allow a variety of easily implemented options for operation.

CONCLUSION

The system described here provides heart rate and two body temperature measurements. The implantable transmitter is pulsed at each heartbeat with an interruption of 1-2 sec every 50 beats for transmission of temperature data. Low-powered, integrated circuits allow the system to be operated for a year or longer in animals that weigh a few kilograms or more. Direct transmission to an AM receiver operating at 54 MHz is possible at maximum ranges estimated to be 200 m. A retransmitter collar allows long-range transmission at 148 MHz. Radio-frequency links, originally designed for animal tracking, are used for retransmission. Physiological data can be recovered at distances within 80% of the maximum tracking range.

The system is designed to provide flexible capabilities, both at the transmitting and receiving ends. The transmitter's circuitry can be readily altered to sample more temperature sensors, and at different heartbeat intervals, or to transmit only the heartbeats or only the temperatures at the decade counts of heartbeats. The demodulator is microprocessor controlled so that software changes and added memory can accommodate transmitter modifications, along with linearization of data parameters.

APPENDIX

TEMPERATURE AND HEART RATE BIOTELEMETRY

DEMULATOR PROGRAM ¹⁵

TEMPERATURE AND HEART RATE BIOTELEMETRY DEMODULATOR

```

0000      0005 ;*****
0000      0010 ;*
0000      0015 ;*      NASA AMES RESEARCH CENTER      *
0000      0020 ;*      MOUNTAIN VIEW, CA      *
0000      0025 ;*
0000      0030 ;*      WRITTEN BY RAFAEL MIRANDA, E.E.      *
0000      0035 ;*      JANUARY 1979      *
0000      0040 ;*
0000      0045 ;*      NOTE: 280 ASSEMBLY LANGUAGE CODE.      *
0000      0050 ;*
0000      0055 ;*****
0000      0060 ;
0000      0065 ; INPUT AND OUTPUT PORT ASSIGNMENTS
0000      0070 ;
0000      0075 PORT0: EQU 0      ; ECG LED READOUT X10
0001      0080 PORT1: EQU 1      ; X103
0002      0085 PORT2: EQU 2      ; T1 LED READOUT X1
0003      0090 PORT3: EQU 3      ; X10
0004      0095 PORT4: EQU 4      ; T2 LED READOUT X1
0005      0100 PORT5: EQU 5      ; X10
0007      0105 PORT7: EQU 7      ; FRONT PANEL IN PORT
                                AND YBG RESET FLAG.
0000      0110 ;
0000      0115 ;
0000      0120 ;      **** **
0000      0125 ;      *
0000      0130 ;      *      C O N S T A N T S      *
0000      0135 ;      +
0000      0140 ;      **
0000      0145 ;
0000      0150 ZERO: EQU 00H
0001      0155 ONE: EQU 01H
0002      0160 TWO: EQU 02H
0003      0165 EIGHT: EQU 08H
0004      0170 NINE: EQU 09H
0005      0175 TEN: EQU 10
0006      0180 ELEVEN: EQU 11H
0007      0185 FIFTY: EQU 50
0008      0190 ;
0009      0195 ; SIXTY THOUSAND MILLISECONDS
0010      0200 SIXTY: EQU 60000
0011      0205 INF: EQU 0FFH      ; INFINITY
0012      0210 ;
0013      0215 ; TEMPERATURE PULSE WIDTH LIMITS
0014      0216 ;      1N MILLISECONDS
0015      0220 ;
0016      0225 TMLPW: EQU 10      ; LOW TEMP LIMIT
0017      0230 TMLPW: EQU 25      ; HIGH TEMP LIMIT
0018      0235 ECLW: EQU 6      ; LOW LIMIT ECG
0019      0240 ECUW: EQU 11      ; UPPER LIMIT ECG
0020      0245 ;
0021      0250 ; CALIBRATION TIME FOR 600 MSEC
0022      0255 CALTL: EQU 58H      ; CAL TIME LOW (BYTE)
0023      0260 CALTH: EQU 62H      ; CAL TIME HIGH (BYTE)
0024      0265 ;
0025      0270 ; NUMBER OF PULSES IN TEMPERATURE CYCLE
0026      0275 FIVEDP: EQU 5*2
0027      0280 ;
0028      0285 ; 15 BIT DIVISION SHIFT COUNT:

```

TEMPERATURE AND HEART RATE BIOTELEMETRY DEMODULATOR

```

0011          0290 SHFCNT EQU 17
0012          0295 ;INTERRUPT RESTART ROUTINES
0013          0300 ;
0014          0305 ;ENABLED BY HARDWARE ONLY
0015          0310 ;
0016          0315 ;*****
0017          0320 ;
0018          0325 ;RSTRT: RE-START LOCATION FORCED BY HITTING
0019          0330 ; THE RESET SWITCH IN THE FRONT
0020          0335 ; PANEL OR DURING POWER-ON START UP
0021          0340 ; PROCEDURE.
0022          0345 ;
0023          0350 ;*****
0024          0355 ;
0025          0360 ;ORG 0000H
0026          0365 ;
0027          0370 RSTRT: DI ;DISABLE HARDWARE INT.
0028          0375 LD SP,ERAM ;STACK TO END OF RAM
0029          0380 JP RESET
0030          0385 ;
0031          0390 ;
0032          0395 DW 0
0033          0400 DW 0
0034          0405 DW 0
0035          0410 DW 0
0036          0415 DW 0
0037          0420 DW 0
0038          0425 LW 0
0039          0430 DW 0
0040          0435 DW 0
0041          0440 DW 0
0042          0445 DW 0
0043          0450 DW 0
0044          0455 DW 0
0045          0460 ;
0046          0465 ;*****
0047          0470 ;
0048          0475 ;NEGRST
0049          0480 ;
0050          0485 ; NEGATIVE GOING PULSE RESTART LOCATION
0051          0490 ; RST4 ... LOWEST PRIORITY
0052          0495 ; GETS FLAG AND VERIFIES IF THE LAST
0053          0500 ; FLAG WAS AN ECG FLAG OR A TEMPERATURE
0054          0505 ; FLAG
0055          0510 ;
0056          0515 ; PRESERVES ALL REGISTERS
0057          0520 ;*****
0058          0525 ;
0059          0530 NEGRST PUSH AF
0060          0535 PUSH HL
0061          0540 LD HL,DUMTM
0062          0545 JP NEGRST ;EXIT TO CONTINUATOR

```

ORIGINAL PAGE IS
OF POOR QUALITY

TEMPERATURE AND HEART RATE BIOTELEMETRY DEMODULATOR

```

0028      0555 ;*****
0028      0560 ;
0028      0565 ;PUSRST.
0028      0570 ;      POSITIVE GOING PULSE RESTART LOCATION
0028      0575 ;      RST5 ... PRIORITY=2 (1=HIGHEST)
0028      0580 ;      STORES TIME INTERVAL BETWEEN PULSES
0028      0585 ;      IN "TIME", TO BE USED IN COMPUTATIONS
0028      0590 ;
0028      0595 ;      PRESERVES ALL REGISTERS
0028      0600 ;*****
0028      0605 ;
0028      F5      0610 POSRST: PUSH  AF
0028      E5      0615      PUSH  HL
0028      21 01 0C 0620      LD    HL,DUMTM
0028      C3 0C 00 0625      JP    POSCNT ;EXIT TO CONTINUATOR
0030      0630 ;
0030      0635 ;
0030      0640 ;
0030      0645 ;
0030      0650 ;
0030      0655 ;*****
0030      0660 ;
0030      0665 ;TBRST:
0030      0670 ;      TIME BASE GENERATOR RESTART LOCATION
0030      0675 ;      RST6 ... HIGHEST PRIORITY
0030      0680 ;      INCREMENTS "DUMTM" BY ONE
0030      0685 ;
0030      0690 ;      PRESERVES ALL REGISTERS
0030      0695 ;
0030      0700 ;*****
0030      0705 ;
0030      F5      0710 TBRST: PUSH  AF
0030      E5      0715      PUSH  HL
0030      21 01 0C 0720      LD    HL,DUMTM
0030      C3 BA 00 0725      JP    TBCNT ;EXIT TO CONTINUATOR

```

TEMPERATURE AND HEART RATE BIOTELEMETRY DEMODULATOR

```

0038      0735  ;*****
0038      0740  ;
0038      0745  ;RESET:
0038      0750  ;      RSTRT CONTINUATOR
0038      0755  ;      INITIALIZES FRONT PANEL LED DISPLAYS
0038      0760  ;      TO
0038      0765  ;      000      00.0      00.0
0038      0770  ;      READS FRONT PANEL SWITCHES
0038      0775  ;
0038      0780  ;*****
0038      0785  ;
0038      0790  RESET:  IN      A,PORT7      ;READ SWITCHES
0038      0795      LD      B,A
0038      0800      AND     ONE
0038      0805      JP     Z,CAL      ;IF PORT7=1..CALIBRATE
0040      0810  ;
0040      0815  OR'IE:  XOR     A      ;CLEAR HCC. AND CY
0041      21 00 0C      0820      LD      HL,RAM      ;RAM ORG. TO HL
0044      06 13      0825      LD      B,RAMEND
0046      0830  ;
0046      77      0835  CLRLP:  LD      (HL),A      ;CLEAR RAM
0047      05      0840      DEC     B
0048      23      0845      INC     HL
0049      88      0850      CP     B      ;WAIT UNTIL B=0H
004A      C2 46 00      0855      JP     NZ,CLRLP
004D      0860  ;
004D      0865  ;CLEAR ALL LED DISPLAYS
004D      0870  ;
004D      D3 00      0875      OUT     PORT0,A
004F      D3 01      0880      OUT     PORT1,A
0051      D3 02      0885      OUT     PORT2,A
0053      D3 03      0890      OUT     PORT3,A
0055      D3 04      0895      OUT     PORT4,A
0057      D3 05      0900      OUT     PORT5,A
0059      0905  ;
0059      0910  ;RESET REHL TIME CLOCK
0059      0915  ;
0059      D3 07      0920      OUT     PORT7,A
005B      3E 01      0925      LD      A,ONE      ;SET UP START OF CLOCK
005D      D3 07      0930      OUT     PORT7,A      ;START 1 MSEC TIMER
005F      0935  ;
005F      FB      0940      EI      ;ALLOW HARDWARE INT.
0060      0945  ;
0060      C3 60 00      0950  WAIT:  JP     WAIT      ;WAIT FOR AN INTERRUPT

```

TEMPERATURE AND HEART RATE BIOTELEMETRY DEMODULATOR

```

0063          0960 ;*****
0063          0965 ;
0063          0970 ;NEGCNT:
0063          0975 ; CONTINUATOR ROUTINE TO NEGRST
0063          0980 ; CHECKS TIME INTERVAL BETWEEN PULSES
0063          0985 ; IF IT CHECKS WITHIN THE PRE-SET LIMITS
0063          0990 ; UPDATES THE ECG OR TEMP. FLAG
0063          0995 ;
0063          1000 ;*****
0063          1005 ;
0063 3E 12      1010 NEGCNT: LD  A,AMPLW ;GET TEMP LOWER LIMIT
0065 BE        1015      CP  (HL)
0066 D2 6F 00  1020      JP  NC,NXTST ;IF G.T. CONTINUE
0069 7E        1025      LD  A,(HL) ;TEST UPPER LIMIT
006A FE 19     1030      CP  TMPUN ;IF L.T GO TO TEMPF
006C DA 7F 00  1035      JP  C,TEMPF ;IF NOT CONTINUE
006F          1040 ;
006F 3E 06     1045 NXTST: LD  A,ELGLW ;GET ECG LOWER LIMIT
0071 BE        1050      CP  (HL)
0072 D2 7B 00  1055      JP  NC,NFLG ;EXIT IF SMALLER
0075 7E        1060      LD  A,(HL)
0076 FE 08     1065      CP  ECGUN ;IF L.T. GO TO ECGF
0078 DA 84 00  1070      JP  C,ECGF ;IF NOT CONTINUE
007B          1075 ;
007B AF        1080 NFLG  XOR  A ;CURRENT FLAG=0
007C C3 86 00  1085      JP  ENDNEG
007F          1090 ;
007F 3E 02     1095 TEMPF: LD  A,TWU ;PULSE W/IN TEMP LIMIT
0081 C3 86 00  1100      JP  ENDNEG
0084          1105 ;
0084 3E 01     1110 ECGF:  LD  A,ONE ;PULSE W/IN TEMP LIMIT
0086          1115 ;
0086 26        1120 ENDNEG: DEC  HL
0087 77        1125      LD  (HL),A ;STORE RESULT IN "FLAG"
0088          1130 ;
0088 E1        1135      POP  HL
0089 F1        1140      POP  AF
008A FB        1145      EI ;ALLOW HIGHER
008B          1150 ; PRIORITY INTERRUPTS
008B          1155 ;
008B C9        1160      RET

```

TEMPERATURE AND HEART RATE BIOTELEMETRY DEMODULATOR

```

008C      1170 ;*****
008C      1175 ;
008C      1180 ;POSCNT:
008C      1185 ;      CONTINUATOR ROUTINE TO POSRST
008C      1190 ;      STORES TEMPORARY VALUE OF "DUMTM"
008C      1195 ;      INTO "TIME".  CLEARS TEMPORARY VALUE
008C      1200 ;      OF "DUMTM"; COMPUTES H.R. OR TEMP
008C      1205 ;
008C      1210 ;      CHECKS "BUSY" FLAG (IF "BUSY", RETURNS
008C      1215 ;      WAITS FOR INTERRUPTS
008C      1220 ;
008C      1225 ;*****
008C      1230 ;
008C      1235 POSCNT: OUT  FURT?,A  ;RESET 1 MSCL TIMER
008E      7E      LD    A,(HL)  ;GET LOW BYTE OF TIME
008F      32 02 0C  LD    (TIME),A  ;STORE IT IN "TIME"
0092      AF      XOR    A
0093      77      LD    (HL),A  ;CLEAR TEMPO. STORAGE
0094      23      INC    HL
0095      7E      LD    A,(HL)  ;DO THE SAME FOR
0096      32 03 0C  LD    (TIME+1),A;HIGH ORDER BYTE
0099      AF      XOR    A
009A      77      LD    (HL),A  ;CLEAR TEMPO. STORAGE
009B      1285 ;
009B      3A 12 0C  LD    A,(BUSY) ;CHECK IF BUSY
009E      FE 01      CP    ONE  ;IF NOT DONE RETURN
00A0      C2 A7 00  JP    NZ,SKIPIT ;IF DONE GO TO SKIPIT
00A3      E1      1305 ;
00A3      F1      1310      POP   HL
00A4      F1      1315      POP   AF
00A5      1320 ;
00A5      FB      1325      EI      ;ALLOW HARDWARE INT.
00A6      C9      1330      RET
00A7      1335 ;
00A7      E1      1340 SKIPIT: POP   HL
00A8      F1      1345      POP   AF  ;FLAG HAS DONE
00A9      FB      1350      EI      ;ALLOW 180 TO INT
00AA      1355 ;
00AA      3A 00 0C  LD    A,(FLAG)
00AD      47      LD    B,A  ;PREVENT CHANGING THE
00AE      E6 01      AND   ONE  ;TIME VALUES
00B0      C2 C7 00  JP    NZ,ECG SUB ;IF FLAG=1 THEN ECG SUB
00B3      1380 ;
00B3      70      LD    A,B
00B4      E6 02      AND   TWO  ;TEMP CALCULATION?
00B6      C2 04 01  JP    NZ,TPSUB ;IF NOT RETURN TO WAIT
00B9      1400 ;
00B9      C9      1405      RET

```

TEMPERATURE AND HEART RATE BIOTELEMETRY DEMODULATOR

```

00BA      1415 ;*****
00BB      1420 ;
00BA      1425 ;TBCNT:
00BA      1430 ; CONTINUATOR ROUTINE TO IBGRST
00BA      1435 ; INCREMENTS TEMPORARY STORAGE FOR TIME
00BA      1440 ; BY ONE MILLISECOND. RETURNS
00BA      1445 ;
00BA      1450 ; ALL REGISTERS PRESERVED
00BA      1455 ;
00BA      1460 ;*****
00BA      1465 ;
00BA      1470 ;
00BA 3E 01 1475 TBCNT: LD A,ONE ;INCREMENT "DUMTM"
00BC 86 1480 ADD (HL) ;BY ONE
00BD 77 1485 LD (HL),A ;STORE IT
00BE 23 1490 INC HL ;INCR. HIGH ORDER BYTE
00BF 3E 00 1495 LD A,ZERO
00C1 8E 1500 ADC (HL) ;ADD CY TO (HIGH) BYTE
00C2 77 1505 LD (HL),A ;BYTE AND STORE IT
00C3 1510 ;
00C3 E1 1515 POP HL
00C4 F1 1520 PUP AF
00C5 1525 ;
00C5 FB 1530 EI ;ALLOW HARDWARE INT.
00C6 C9 1535 RET

```

TEMPERATURE AND HEART RATE BIOTELEMETRY DEMODULATOR

```

00C7      1545 ;*****
00C7      1550 ;
00C7      1555 ;ECGSUB:
00C7      1560 ;   COUNTS NUMBER OF ECG PULSES:
00C7      1565 ;   CALCULATES HEART RATE
00C7      1570 ;   CONVERTS BINARY RESULT TO BCD
00C7      1575 ;   OUTPUTS RESULT TO FRONT PANEL
00C7      1580 ;   RETURNS TO WAIT FOR A NEW
00C7      1585 ;   INSTRUCTION OR INTERRUPT
00C7      1590 ;
00C7      1595 ;*****
00C7      1600 ;
00C7      3A 09 0C 1605 ECGSUB: LD   A,(ECGCNT);GET NUMBER OF R WAVES
00C7      FE 00      1610   CP   ZERO      ;IS IT THE FIRST BEAT?
00C7      C2 DE 00   1615   JP   NZ,CNT1  ;IF YES, CONTINUE
00CF      1620 ;
00CF      1625 ;FIRST BEAT INDICATES A T CYCLE OR ECG BEAT
00CF      1630 ;
00CF      3A 06 0C 1635   LD   A,(CTRTEM);GET # OF TEMP. PULSES
00D2      FE 0A      1640   CP   FIVEDP  ;IS # OF PULSES
00D4      1645 ;EQUAL TO FIVE?. IF YES GO TO INPUT
00D4      1650 ;TO CALCULATE TEMPERATURES & OUTPUT RESULTS
00D4      CA C8 01   1655   JP   Z,IMP001
00D7      1660 ;
00D7      AF      1665   XOR   A      ;NOT A TEMP CYCLE
00D8      32 06 0C 1670   LD   (CTRTEM),A;RESET TEMP COUNTER
00D8      C3 E4 00   1675   JP   GOBACK
00DE      1680 ;
00DE      FE 32      1685 CNT1:  CP   FIFTY   ;50 R WAVES COUNTED?
00E0      C2 E9 00   1690   JP   NZ,SKPCLR ;IF NOT CONTINUE
00E3      AF      1695   XOR   A      ;CLEAR R WAVE COUNT
00E4      1700 ;
00E4      3C      1705 GOBACK: INC  A
00E5      32 09 0C 1710   LD   (ECGCNT),A;STORE VALUE OF ONE
00E8      C9      1715   RET
00E9      1720 ;
00E9      3C      1725 SKPCLR: INC  A      ;UPDATE R WAVE COUNT
00EA      32 09 0C 1730   LD   (ECGCNT),A;STORE IT
00ED      1735 ;
00ED      1740 ;START CALCULATING HEART RATE
00ED      1745 ;
00ED      CD 25 01   1750   CALL BSYPDNE ;SET BUSY FLAG
00F0      11 00 EA   1755   LD   DE,SIXTY ;DIVIDEND=60000 MSEC.
00F3      1760 ;
00F3      1765 ;DIVIDE 60000 MSEC BY RR INTERVAL IN "TIME"
00F3      1770 ;
00F3      CD 37 01   1775   CALL DIVIDE  ;GET BINARY HEART RATE
00F6      CD 71 01   1780   CALL BINBCD  ;BINARY TO DECIMAL
00F9      1785 ;
00F9      79      1790   LD   A,C      ;GET H.R. X 1
00FA      D3 00      1795   OUT  PORT0,A  ;LEAST SIGNIFICANT LED
00FC      78      1800   LD   A,B      ;Get Heart rate X 100
00FD      D3 01      1805   OUT  PORT1,A  ;most significant HR
00FF      AF      1810   XOR   A      ;CLEAR BUSY FLAG
0100      32 12 0C 1815   LD   (BUSY),A  ;STORE IT
0103      1820 ;
0103      C9      1825   RET

```

TEMPERATURE AND HEART RATE BIOTELEMETRY DEMODULATOR

```

0104      1835 ;*****
0104      1840 ;*
0104      1845 ;* TMAPSUB:
0104      1850 ;* STORES TEMPERATURE INTERVAL IN
0104      1855 ;* SEQUENCE: T0(REF), T1, T2, T50(REF)
0104      1860 ;* CLEARS R WAVE COUNT
0104      1865 ;*
0104      1870 ;*****
0104      1875 ;
0104      1880 TMAPSUB: CALL BSYDNE
0107      1885 ;
0107      1890 LD A,(CTRTEM);GET TEMP. CYCLE COUNT
010A      1895 INC A
010B      1900 INC H ;UPDATE IT BY TWO
010C      1905 LD (CTRTEM),A,STORE IT
010F      1910 ;
010F      1915 LD HL,SAYTIM ;MAYBE IT
0112      1920 ADD L
0113      1925 LD L,A ;UPDATE T CYCLE PTR
0114      1930 LD A,(DIVTM)
0117      1935 LD (HL),A ;STORE TIME INTERVAL
0118      1940 ;
0118      1945 INC HL
0119      1950 LD A,(DIVTM+1)
011C      1955 LD (HL),A ;HIGH ORDER BYTE
011D      1960 XOR A ;CLEAR ECG COUNT
011E      1965 LD (ECGINT),A
0121      1970 ;
0121      1975 LD (BUSY),A
0124      1980 ;
0124      1985 RET
0125      1990 ;
0125      1995 ;*****
0125      2000 ;*
0125      2005 ;* BSYDNE:
0125      2010 ;* SETS UP BUSY FLAG
0125      2015 ;* MOVES TEMPORARY TIME INTERVAL
0125      2020 ;* TO "DIVTM"...TIME TO BE USED IN
0125      2025 ;* COMPUTATIONS
0125      2030 ;*
0125      2035 ;*****
0125      2040 ;
0125      2045 BSYDNE LD A,ONE ;SET UP BUSY FLAG
0127      2050 ;
0127      2055 LD (BUSY),A
012A      2060 LD HL,TIME
012D      2065 LD A,(HL) ;GET LOW ORDER TIME
012E      2070 LD (DIVTM),A ;STORE IT IN PERMNT.
0131      2075 INC HL
0132      2080 LD A,(HL) ;HIGH ORDER TIME
0133      2085 LD (DIVTM+1),A,STORE IT
0136      2090 ;
0136      2095 RET

```

TEMPERATURE AND HEART RATE BIOTELEMETRY DEMODULATOR:

```

0171          2395 ;*****
0171          2410 ;
0171          2405 ; BINBCD:
0171          2410 ;      16 BIT BINARY TO BCD CONVERSION
0171          2415 ;      BINARY NUMBER IN HL:
0171          2420 ;      H=HIGH L=LOW ORDER BYTE
0171          2425 ;      RESULT: A=%10,000 B=%100 C=%1
0171          2430 ;
0171          2435 ;*****
0171          2440 ;
0171 1E 11      2445 BINBCD LD E,ELEVH ;SET BIT COUNTER
0173 CD 84 01   2450 CALL BCD
0176 4F         2455 LD C,A ;SAVE L.SIG. BCD BYTE
0177 1E 11      2460 LD E,ELEVH
0179 C3 7E 01   2465 JF BNEXT
017C          2470 ;
017C 1E 02      2475 LD E,AINE
017E CD 84 01   2480 BNEXT: CALL BCD
0181 47         2485 LD B,A
0182 7D         2490 LD A,L
0183 C9         2495 RET ;DONE
0184          2500 ;
0184 AF         2505 BCD:  NOP A
0185 1D         2510 CVT:  DEC E
0186 C8         2515 RET Z
0187 29         2520 ADD HL,HL
0188 8F         2525 ADC A
0189          2530 ;
0189 27         2535 DAA
018A D2 85 01   2540 JF NC,CVT
018D 23         2545 INC HL
018E C3 85 01   2550 JF CVT

```

TEMPERATURE AND HEART RATE BIOTELEMETRY DEMODULATOR

```

0191          2560 ; *****
0191          2565 ;
0191          2570 ; MULT          \
0191          2575 ;          16 BIT BY 8 BIT MULTIPLICATION
0191          2580 ;          BC=MULTIPLICAND  X H(MULTIPLIER)=
0191          2585 ;          DE(PRODUCT). BC X H=DE REGISTERS
0191          2590 ;
0191          2595 ; *****
0191          2600 ;
0191  11 00 00  2605 MULT:  LD    DE,CERO  ;ERASE PRODUCT
0194          2610 ;
0194  87       2615 MLOOP:  OR    A          ;CLEAR CARRY
0195  7C       2620          LD    A,H
0196  1F       2625          RRA
0197  67       2630          LD    H,R
0198          2635 ;
0198          2640 ;IF MULTIPLIER BIT=1,ADD MPEND TO PRODUCT
0198  DC A7 01  2645          CALL C,MADD
019B          2650 ;
019B  7C       2655          LD    A,H          ;EXIT IF MPIER IS 0
019C  A7       2660          RND    A
019D  C8       2665          RET    Z          ;RETURN
019E          2670 ;
019E  79       2675          LD    A,C          ; OTHERWISE
019F  17       2680          RLA          ; SHIFT
01A0  4F       2685          LD    C,A          ; MULTIPLICAND
01A1  78       2690          LD    A,B          ; LEFT
01A2  17       2695          RLH          ; AND
01A3  47       2700          LD    B,R          ; REPEAT
01A4  C3 94 01  2705          JF    MLOOP
01A7          2710 ;
01A7  79       2715 MADD:  LD    A,C          ;ADD PARTIAL
01A8  83       2720          ADD    E          ;PRODUCT
01A9  5F       2725          LD    E,A
01AH  78       2730          LD    A,B
01AB  8A       2735          ADC    D
01AC  57       2740          LD    D,H
01AD  C9       2745          RET

```

TEMPERATURE AND HEART RATE BIOTELEMETRY DEMODULATOR

```

01AE          2755 ;*****
01AE          2760 ;
01AE          2765 ; MPY%10:
01AE          2770 ;     MULTIPLIES DE REGISTER BY 10
01AE          2775 ;     AND PLACES RESULT IN DE
01AE          2780 ;
01AE          2785 ;     REGISTERS AFFECTED: HL,AB,DE
01AE          2790 ;
01AE          2795 ;*****
01AE          2800 ;
01AE 60       2805 MPY%10: LD     L,E     ;MOVE HL TO DE
01AF 62       2810         LD     H,D
01B0 00 FD    2815         LD     B,-3    ;SET UP COUNT
01B2 B7       2820         OR     A      ;CLEAR CARRY
01B3         2825 ;
01B3 04       2830 LOOP%10: INC    B
01B4 7D       2835         LD     A,L
01B5 17       2840         RLA
01B6 6F       2845         LD     L,A    ;MULTIPLY RESULT
01B7 7C       2850         LD     A,H    ; BY
01B8 17       2855         RLA        ; EIGHT
01B9 67       2860         LD     H,A
01BA 78       2865         LD     A,B
01BB 02 B3 01 2870         JP     NZ,LOOP%10 ;X8 IN HL REG.
01BE         2875 ;
01BE B7       2880         OR     A      ;MULTIPLY
01BF 7B       2885         LD     A,E    ; AGAIN
01C0 17       2890         RLA        ; BY
01C1 5F       2895         LD     E,A    ; TWO
01C2 7A       2900         LD     A,D
01C3 17       2905         RLA
01C4 57       2910         LD     D,A    ;X2 IN DE REG.
01C5 19       2915         ADD    HL,DE  ;ADD X8 + X2
01C6 EB       2920         EX     DE,HL  ;RESULT TO DE
01C7         2925 ;
01C7 C9       2930         RET

```

TEMPERATURE AND HEART RATE BIOTELEMETRY DEMODULATOR

```

01C8      2940 ;*****
01C8      2945 ;
01C8      2950 ; TMPOUT:
01C8      2955 ;     COMPUTES T1 AND T2 (UNKNOWN):
01C8      2960 ;
01C8      2965 ; T(UNKNOWN)=(T(UNKNOWN)-T0)/(150-T0)*50
01C8      2970 ;
01C8      2975 ;     IF T50 WAS NOT UPDATED OR
01C8      2980 ;     IF T(UNKNOWN)-T0 IS NEGATIVE OR
01C8      2985 ;     IF RESULT IS G.T 50 IT ABORTS
01C8      2990 ;
01C8      2995 ;     OUTPUTS RESULTS TO FRONT PANEL
01C8      3000 ;
01C8      3005 ;     DISABLES INTERRUPTS DURING CRITICAL
01C8      3010 ;     CALCULATIONS
01C8      3015 ;
01C8      3020 ;*****
01C8      3025 ;
01C8 3E 01      3030 TMPOUT: LD    R,ONE      ;SET BUSY FLAG
01C9 32 12 0C   3035      LD    (BUSY),R  ;STORE IT
01CD 32 09 0C   3040      LD    (ECGCNT),R;ECG COUNT=1
01D0 1F        3045      XOR   R          ;CLEAR CARRY
01D1 32 06 0C   3050      LD    (CTRTEM),R;TEMP CTR=0
01D4          3055 ;
01D4 21 10 0C   3060      LD    HL,TEMPST+6; GET T50(REF)
01D7 7E        3065      LD    A,(HL)    ;A HAS T50
01D8 FE 00     3070      CP    ZERO      ;UPDATED?
01DA CC 10 02   3075      CALL  Z,TEST2   ;IF NOT,RETURN
01DD          3080 ;
01DD 21 0A 0C   3085      LD    HL,TEMPST ;GET T0 (REF)
01E0 4E        3090      LD    L,(HL)    ;C HAS LOW ORDER BYT
01E1 96        3095      SUB   (HL)
01E2 32 03 0C   3100      LD    (DIVTM),A ;PARTIAL RESULT
01E5 21 11 0C   3105      LD    HL,TEMPST+7;BYTE 2
01E8 7E        3110      LD    A,(HL)
01E9 21 08 0C   3115      LD    HL,TEMPST+1;T0 (REF) HIGH
01EC F3        3120      DI
01ED 46        3125      LD    B,(HL)
01EE 9E        3130      SBC   (HL)      ;T50-T0 HIGH ORDER
01EF DA 08 02   3135      JP    C,CLRFLG  ;IF NEGATIVE EXIT
01F2 32 04 0C   3140      LD    (DIVTM+1),A;STORE IT
01F5 23        3145      INC   HL        ;GET T1 POINTER
01F6 C5        3150      PUSH  BC
01F7          3155 ;
01F7 CD 27 02   3160      CALL  TMPG0     ;CALCULATE T1
01FA D3 02     3165      OUT   PORT2,A  ;T1 TO LED display
01FC 78        3170      LD    H,B       ;Most significant
01FD D3 03     3175      OUT   PORT3,A  ;result to T1
01FF C1        3180      POP   BC
0200          3185 ;
0200 21 0E 0C   3190      LD    HL,TEMPST+4;GET T2 POINTER
0203 CD 27 02   3195      CALL  TMPG0     ;CALCULATE T2
0206          3200 ;
0206 D3 04     3205      OUT   PORT4,A  ;L.S. BCD out
0208 78        3210      LD    H,B       ;Most significant
0209 D3 05     3215      OUT   PORT5,A  ;result to T2

```

TEMPERATURE AND HEART RATE BIOTELEMETRY DEMODULATOR

```

0208          3225 ;          ****+*****+*****+*****+
0208          3230 ;          *
0208          3235 ;          *      INPUT (CONTINUATION)      *
0208          3240 ;          *
0208          3245 ;          ****+*****+*****+*****+
0208          3250 ;
0208 FB       3255 CLRFLG E1
0208 AF       3260 NOR      A          ;CLEAR BUSY FLAG
0208 32 10 0C 3265 LD      (TEMPST+6),A ;CLEAR TSO,REF)
0210 32 11 0C 3270 LD      (TEMPST+7),A
0213 32 12 0C 3275 LD      (BUSY),A
0216 C9      3280 RET          ;RETURN TO MAIN PROG.
0217          3285 ;
0217          3290 ;
0217 21 0B 02 3295 EXEND  LD      HL,CLRFLG ;EXCHANGE
021A C1       3300 POP      BC          ;TOP OF STACK
021B E3       3305 EX      (SP),HL ;: RETURN TO CLR FLG
021C C9      3310 RET
021D          3315 ;
021D          3320 ;
021D 4F       3325 TEST2: LD      C,A          ;STORE HIGH BYTE
021E 23      3330 INC      HL
021F 7E      3335 LD      A,(HL)
0220 C6 06   3340 ADD     ZERO          ;TEST LOW BYTE
0222 CA 0B 02 3345 JP      Z,CLRFLG
0225 79      3350 LD      H,C          ;RESTORE (HIGH) BYTE
0226 C9      3355 RET
0227          3360 ;
0227          3365 ;
0227 AF       3370 TMPGD: NOR     A          ;CALCULATE TEMP
0228 7E      3375 LD      A,(HL)
0229 91      3380 SUB     C
022A 4F      3385 LD      C,A
022B          3390 ;
022B 23      3395 INC     HL          ;SUBTRACT
022C 7E      3400 LD      H,(HL)          ;T50(REF)-T0(REF)
022D 98      3405 SBC     B
022E DA 17 02 3410 JP      C,EXEND ;IF NEGATIVE RETURN
0231 47      3415 LD      B,A          ;TEMP STORE
0232          3420 ;
0232 21 03 0C 3425 LD      HL,DIVTM
0235 7E      3430 LD      A,(HL)
0236 3C      3435 INC     A
0237 91      3440 SUB     C          ;BC=T1 OR T2-T0(REF)
0238 23      3445 INC     HL
0239 7E      3450 LD      A,(HL)
023A 98      3455 SBC     B          ;(T50-T0+1)-(T1-T0)
023B DA 17 02 3460 JP      C,EXEND ;IF NEG.RETURN
023E 26 32   3465 LD      H,FIFTY ;DEGREES
0240          3470 ;
0240 CD 91 01 3475 CALL    MULT          ;CALCULATE T1 OR T2
0243 CD 4B 02 3480 CALL    DIVSP
0246 CD 71 01 3485 CALL    BINBCD
0249 75      3490 LD      A,L          ;Result XI
024A C9      3495 RET

```

TEMPERATURE AND HEART RATE BIOTELEMETRY DEMODULATOR

```

0240      3505 ;*****
024B      3510 ;
0248      3515 ;DIVSP-
024B      3520 ;   CALLED BY TEMP00, IT CALCULATES
0240      3525 ;   ((T1 OR T2)-T0(REF)*50)/(T50-T0)
024B      3530 ;   PRECISE TO ONE DECIMAL PLACE MAX.
024B      3535 ;   DOES NOT ROUND OFF RESULT
024B      3540 ;
024B      3545 ;*****
024B      3550 ;
024B      3555 ;
024B 2A 03 0C      3560 DIVSP: LD   HL,(DIVTM);GET DIVISOR
024E      3565 ;
024E      3570 ;DIVIDE T-T0*50,T50-T0
024E      3575 ;
024E  CD 6B 02      3580      CALL  DIV100
0251  EB          3585      PUSH  HL          ;SAVE REMAINDER
0252      3590 ;
0252  CD AE 01      3595      CALL  MPY%10 ;DE(RESULT)=CE%10
0255  EI          3600      POP   HL          ;SAVE RESULT
0256  DS          3605      PUSH  DE
0257  EB          3610      EX:  DE,HL ;REMAINDER IN DE
0258  CD AE 01      3615      CALL  MPY%10 ;REMAINDER%10 IN DE
025B      3620 ;
025B 2A 03 0C      3625      LD   HL,(DIVTM);DIVIDE AGAIN
025E  CD 6B 02      3630      CALL  DIV100 ;RESULT IN DE REG
0261  EB          3635      EX:  DE,HL ;RESULT TO HL
0262      3640 ;
0262  DI          3645      POP   DE          ;GET FIRST QUOTIENT
0263      3650 ;
0263      3655 ;ADD QUOTIENT TO RESULT
0263      3660 ;
0263  I9          3665      ADD   HL,DE
0264 3E 01      3670      LD   A,ONE
0266  BH          3675      CP   D
0267  DB          3680      RET   NC ;RETURN IF POSITIVE
0268  C3 17 02      3685      JP   ENEND

```

TEMPERATURE AND HEART RATE BIOTELEMETRY DEMODULATOR

```

026B      3695 ;*****
026B      3700 ;
026B      3705 ; DIV16Q:
026B      3710 ; CALLED BY DIVSP: IT CALCULATES
026B      3715 ; T(UNKNOWN) BY DIVIDING DE(DIVIDEND)
026B      3720 ; BY HL (DIVISOR AND REMAINDER)
026B      3725 ; DE=RESULT
026B      3730 ;
026B      3735 ;*****
026B      3740 ;
026B 22 07 0C 3745 DIV16Q: LD (TEMP),HL ;SAVE DIVISOR
026E 21 05 0C 3750 LD HL,BNUM ;STORE BIT COUNT
0271 36 11 3755 LD (HL),ELEVN
0273 01 00 00 3760 LD BC,ZERO ;INIT RESULT
0276 05 3765 PUSH BC
0277 3770 ;
0277 7B 3775 LOPD: LD A,E ;GET LWR DIVIDND BYT
0278 17 3780 RLA
0279 5F 3785 LD E,A ;SHIFT DIVIDEND
027A 7H 3790 LD A,D
027B 17 3795 RLA ;LEFT ONE BIT
027C 57 3800 LD D,A
027D 35 3805 DEC (HL) ;DECR COUNT
027E E1 3810 POP HL ;RESTORE TEMP RESULT
027F C8 3815 RET Z ;ZERO COUNT?
0280 3E 0C 3820 LD A,ZERU
0282 CE 00 3825 ADC ZERU ;ADD CARRY
0284 29 3830 ADD HL,HL ;SHIFT LEFT ONCE
0285 44 3835 LD B,H ;HL TO ACC.
0286 85 3840 ADD L
0287 2A 07 0C 3845 LD HL,(TEMP) ;GET DIVISOR ADDR
028A 95 3850 SUB L ;SUBTRACT IT
028B 4F 3855 LD C,A
028C 78 3860 LD H,B ;TEMP RESULT
028D 9C 3865 SBC H
028E 47 3870 LD B,A
028F 05 3875 PUSH BC ;SAVE TEMP RESULT
0290 D2 95 02 3880 JP NC,SK1PD
0293 09 3885 ADD HL,BC ;ADD DIVISOR BACK
0294 E3 3890 EX (SP),HL ;REPLACE TEMP RESULT
0295 21 05 0C 3895 SK1PD: LD HL,BNUM ;RESTORE HL
0298 3F 3900 CUF ;COMPLEMENT CARRY
0299 C3 77 02 3905 JP LOPD ;REPRT

```

TEMPERATURE AND HEART RATE BIOTELEMETRY DEMODULATOR

```

0290      3915 ;*****
0291      3926 ;
0292      3935 ; CHL
0293      3936 ; EXERCISES ALL SUBROUTINES USED IN
0294      3938 ; CALCULATING HR. OF TEMPS.
0295      3940 ; OUTPUTS RESULTS TO FRONT PANEL
0296      3945 ;
0297      3950 ;*****
0298      3953 ;
0299      3960 CHL: LD A,ONE ;SET UP FLAG
0300      3963 LD (FLAG),A ;FOR HR MODE
0301      3976 LD (LOGCNT),A;SET UP HR ROUTINES
0302      3975 LD A,B
0303      3980 AND TWO ;TEST CAL FLG
0304      3983 JF Z,HLCHL ;IF LOW CAL,CONTINUE
0305      3990 ;
0306      3995 LUCHL: XOR A
0307      4000 LD (TIME),A
0308      4005 LD A,12F ;LARGE INT. BET R WAVES
0309      4010 LD A,(TIME+);STORE IT
0310      4015 CALL GUCHL
0311      4020 LD DE,TABLE ;CAL TABLE
0312      4025 ENDCHL: CALL PCHL ;GET DATA OUT
0313      4036 JP RSTRI ;RE-START PROGRAM
0314      4038 ;
0315      4040 HILCHL: LD A,CALTL ;CAL TIME LOW ORDER TO
0316      4045 LD (TIME),A ;GET TIME=880 MSEC
0317      4050 LD A,CALTH ;CAL TIME HIGH ORDER
0318      4055 LD (TIME+1),A
0319      4060 CALL GUCHL
0320      4065 LD DE,HTABLE ;HIGH CAL TABLE
0321      4070 JP ENDCHL
0322      4075 ;
0323      4080 GUCHL: CALL CALOUT ;ECG OUT
0324      4085 XOR A ;GET TEMP READY
0325      4090 LD (ECGNT),A
0326      4095 LD A,F12EDP ;GET RT CYCLE #
0327      4100 LD (CTRTEM),A;STORE IT
0328      4105 ;
0329      4110 PCHL: LD HL,TEMPST
0330      4115 XOR A
0331      4120 LD B,ETGHT ;GET TABLE COUNT
0332      4125 FRONT: LD A,(DE)
0333      4130 LD (HL),A ;TABLE TO FAN
0334      4135 DEC B
0335      4140 JP Z,PEND ;CONTINUE IF NOT DONE.
0336      4145 INC DE
0337      4150 INC HL ;UPDATE POINTERS
0338      4155 JP PCONT
0339      4160 PEND: CALL CALOUT ;RET TO NORMAL
0340      4165 RET

```

TEMPERATURE AND HEART RATE BIOTELEMETRY DEMODULATOR

```

02F3      4175 ;          *****
02F3      4180 ;          *
02F3      4185 ;          *   CALIBRATION TIME TABLES:   *
02F3      4190 ;          *
02F3      4195 ;          *   NOTE: USED BY CAL ROUTINE   *
02F3      4200 ;          *
02F3      4205 ;          *****
02F3      4210 ;          .
02F3      4215 ;CAL INTERVAL FOR T0,T1,T2 AND T50(REF)
02F3      4220 ;EXPRESSED IN MILLISECONDS
02F3      4225 ;
02F3      02F3      4230 TABLE: EQU      *
02F3      1E 01      4235 T0L:   DM      286
02F3      5A 01      4240 T1L:   DM      346
02F3      5A 01      4245 T2L:   DM      346
02F3      96 01      4250 T50L:  DM      406
02F3      4255 ;
02F3      02F3      4260 ;
02F3      02F3      4265 MTABLE: EQU      *
02F3      1E 01      4270 T0H:   DM      286
02F3      96 01      4275 T1H:   DM      406
02F3      56 01      4280 T2H:   DM      406
0301      96 01      4285 T50H:  DM      406

```

TEMPERATURE AND HEART RATE BIOTELEMETRY DEMODULATOR

```

0303          4295          ORG      0C00H
0C00          4300 ;*****
0C00          4305 ;*
0C00          4310 ;*          RAM MEMORY
0C00          4315 ;*
0C00          4320 ;*****
0C00          4325 ;
0C00          4330 RAM:      EQU      4          .BEGIN SYS RAM
0C00          4335 ;
0C00          4340 FLAG:    DEFS    1
0C00          4345 DUMTH:   DEFS    1          ;TEMPORARY TIME
0C00          4350 TIME:    DEFS    1          ;TIME INTERVAL
0C00          4355 DIVTH:   DEFS    2
0C00          4360 ENUM:    DEFS    1
0C00          4365 CRTEN:   DEFS    1
0C00          4370 TEMP:    DEFS    1
0C00          4375 SAVTH:   DEFS    1
0C00          4380 EDGCNT:  DEFS    1          ;K HAVE COUNT
0C00          4385 TEMPST:  DEFS    8          ;T CYCLE STORE
0C00          4390 ;
0C00          4395 BUSY:    DEFS    1
0C00          4400 RAMEND:  EQU      4-RAM
0C00          4405 ;
0C00          4410 ERANK:   EQU      1600H          ; END OF STACK
0C00          4415

```

REFERENCES

1. Werber, Morton: A Bibliography of Wildlife Movements and Tracking Systems. NASA CR-130380, 1970.
2. Ysenbrandt, H. J. B.; Selten, Th. A. L.; Verschuren, J. J. M.; Kock, T.; and Kimmich, H. P.: Biotelemetry, Literature Survey of the Past Decade. Biotelemetry, vol. 3, 1976, pp. 145-250.
3. Lund, Gordon, F.: Time and Energy Budgets by Telemetry of Heart Rate from Free Ranging Black-Tailed Prairie Dogs in Natural and in Model Environments. Ph.D. Thesis, Dept. of Zoology, University of Iowa, Iowa City, 1974.
4. Lund, Gordon F.; and Folk, G. Edgar, Jr.: Simultaneous Measurements of Heart Rate and Oxygen Consumption in Black-Tailed Prairie Dogs (Cynomys ludovicianus). Comp. Biochem. Physiol., vol. 55A, 1976; pp. 201-206.
5. Sebesta, Paul D.; and Lund, Gordon F.: Overview of NASA Wildlife Sensing Projects. Paper presented at the Pecora IV Symposium on Application of Remote Sensing Data on Wildlife Management, Oct. 10-12, 1978, Sioux Falls, South Dakota. Sponsored by the National Wildlife Federation, Washington, D. C.
6. Fryer, Thomas B.: Implantable Biotelemetry Systems. NASA SP-5094, 1970.
7. Fryer, Thomas B.; and Sandler, Harold: A Review of Implant Telemetry Systems. Biotelemetry, vol. 1, 1974, pp. 351-374.
8. MacKay, Ralph Stuart: Bio-Medical Telemetry. Second ed. John Wiley and Sons, New York, 1970.
9. Baldwin, Howard A.: Instrumentation for Remote Observation of Physiology and Behavior. Ecological Energetics of Homeotherms, Gessaman, J. A., ed, Utah State University Press, Logan. Monograph Series, vol. 20, 1973, pp. 67-76.
10. Fell, Roger B., Skutt, H. Richard; and Waterfield, Allan: A Four-Channel Ultrasonic Telemetry System for Obtaining Physiological Data from Ocean Divers. Biotelemetry, vol. 1, 1974, pp. 50-59.
11. Lin, Wen C.; and Pillay, Sasi K.: A Micropower Pulsewidth-Modulation-Pulse-Position-Modulation Two-Channel Telemetry System for Bio-medical Applications. IEEE Transac, BME vol. 21, 1974, pp. 273-280.
12. Pauley, J. Donald; Reite, Martin; and Walker, Stephen D.: An Implantable Multi-channel Biotelemetry System. Electroencephalography and Clinical Neurophysiology, vol. 37, 1974, pp. 153-160.

13. Smith, E. Norbert: Multichannel Temperature and Heart Rate Radio-Telemetry Transmitter. *J. Appl. Physiol*, vol. 36, 1974, pp. 252-255.
14. Winter, David A.; and Trenholm, Brian G.: Reliable Triggering for Exercise Electrocardiograms. *IEEE Transac, BME* vol. 16, 1969, pp. 75-79.
15. Cupal, Jerry J.; Weeks, R. W.; and Kaltenbach, C.: A Heart-Rate-Activity Biotelemetry System for Use on Wild Big Game Animals. *Biotelemetry III*, Fryer, T. B., H. A. Miller, and H. Sandler, eds., New York, Academic Press, 1976, pp. 219-222.
16. Weeks, R. W.; Long, F. M.; and Cupal, J. J.: An Improved Repeater Heart Rate Telemetry System for Use on Wildlife. *Proceedings of the First International Conference on Wildlife Biotelemetry*, July 27-29, Laramie, Wyoming, 1977, pp. 2-8.
17. Sebesta, P. D.; and Arno, R. D.: Report on 1973 Santa Cruz Summer Study on Wildlife Resource Monitoring. NASA TM-78578, 1979.
18. Ferris, Clifford D.: *Introduction to Bioelectrodes*. Plenum Press, New York, 1974.
19. Geddes, Leslie A.: *Electrodes and The Measurement of Bioelectric Events*. John Wiley and Sons, New York, 1972.
20. Geddes, Leslie A.; and Baker, L. E.: *Principles of Applied Biomedical Instrumentation*. Second ed. John Wiley and Sons, New York, 1975.
21. Miller, Harry A.; and Harrison, Donald C., eds: *Biomedical Electrode Technology, Theory and Practice*. Academic Press, New York, 1974.
22. Neuman, Michael R.: *Biopotential Electrodes*. *Medical Instrumentation Application and Design*, J. G. Webster, ed., Houghton Mifflin Co., Boston, 1978, pp. 215-272.
23. Dymond, Anthony M.: *Recording Electrodes for Chronic Intracerebral Implantation in Man*. *Biomedical Electrode Technology, Theory and Practice*, Miller, H. A. and D. C. Harrison, Academic Press, Inc., New York, 1974, pp. 41-66.
24. Geddes, L. A.; and Baker, L. E.: The Relationship Between Input Impedance and Electrode Area in Recording the ECG. *Med. Biol. Eng.,* vol. 4, 1966, pp. 439-450.
25. Fryer, Tom B.; Lund, Gordon F.; and Williams, Bill A.: An Inductive Powered Telemetry System for Temperature, EKG, and Activity Monitoring. *Biotelemetry and Patient Monitoring*, vol. 5, 1978, pp. 53-76.

26. Lund, Gordon F.; Simmonds, Richard C.; and Williams, Bill A.: A Subcutaneous Channeling Probe for Implanting Long Leads. *Lab. Anim. Sci.*, vol. 27, 1977, pp. 1040-1041.
27. Larsen, J. L.; Dillman, R. F.; Nardizzi, A. M.; and Tverdoch, R. N.: An Effective ECG Telemetry System. *Hewlett-Packard Journal*, vol. 23, no. 8, April 1972, pp. 2-8.
28. Wright, M. J.: Use Slew-Rate Filtering. *Electronic Design*, vol. 24, no. 19, Sept. 1976, pp. 110-12.
29. Deboo, Gordon J.: *An RC Active Filter Design Handbook*. NASA SP-5104, 1977.
30. Courtin, E.; Ruchay, W.; Salfeld, P.; and Sommer, H.: A Versatile, Semiautomatic Fetal Monitor for Non-Technical Users. *Hewlett-Packard Journal*, vol. 28, no. 5, Jan. 1977, pp. 16-23.
31. *RCA COS/MOS Integrated Circuits, Databook SSD-203C*. RCA Solid State, Somerville, New Jersey, 1975, pp. 518-538.
32. Morrow, G.; and Fullmer, H.: Proposed standard for the S-100 Bus Computer, vol. 11, no. 5, May 1978, pp. 84-90.
33. *Intel 8080 Microcomputer System User's Manual*. Intel, Inc., Santa Clara, Calif., Sept. 1975, pp. 2-11.

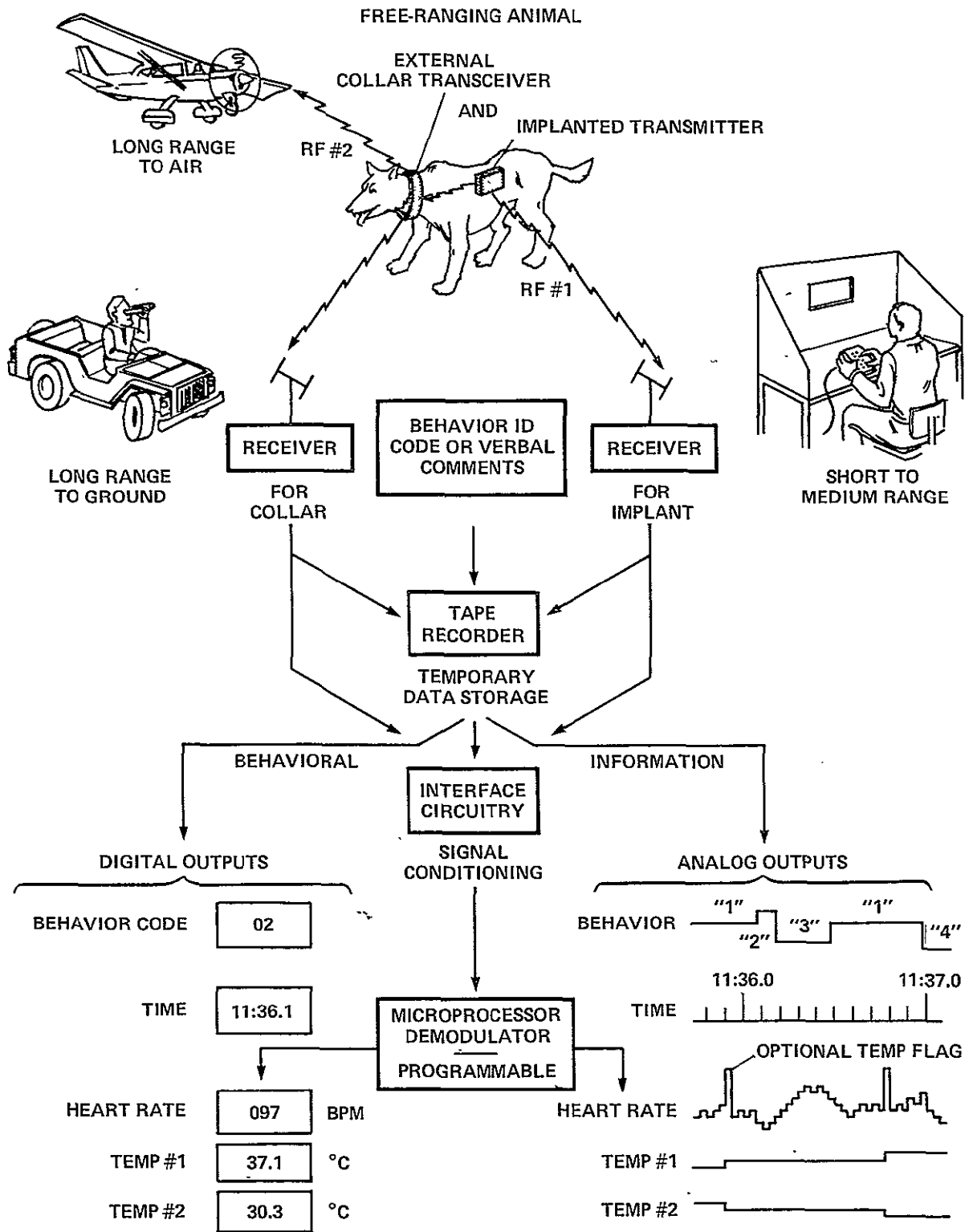
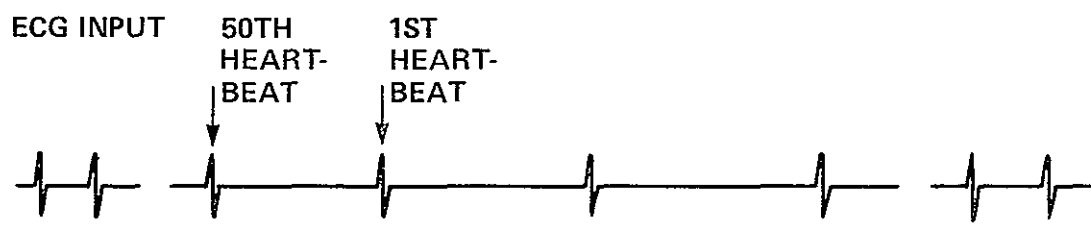
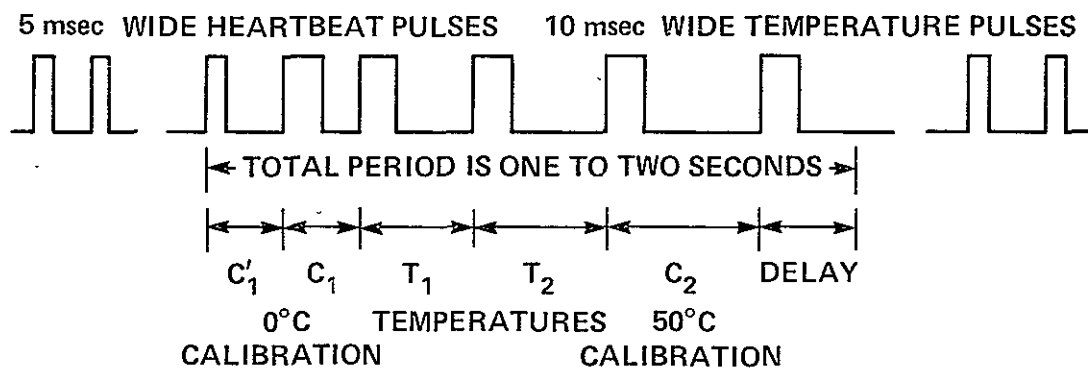

Figure 1.- Telemetry data-acquisition system for heart rate and multiple body temperatures.



TRANSMITTER PULSE CONTROL



RF PULSE TRAIN OUTPUT

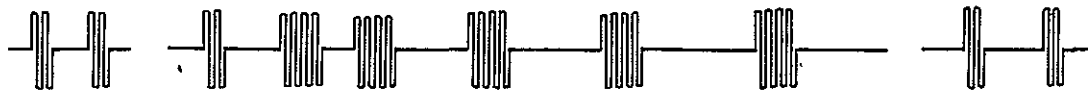

Figure 2.- Modulation scheme for heart rate and multiple body temperatures.

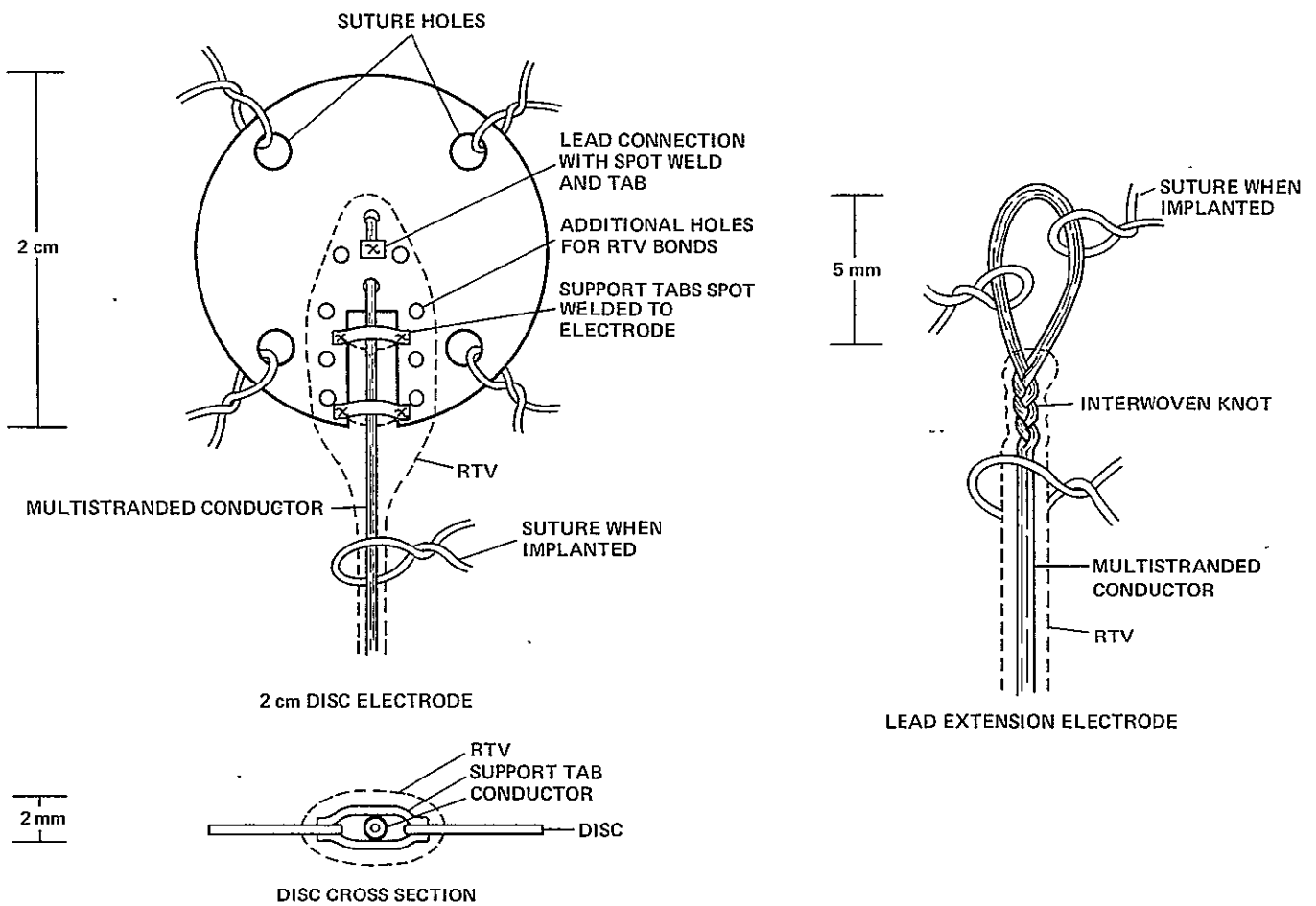

Figure 3.- Implantable ECG electrodes.

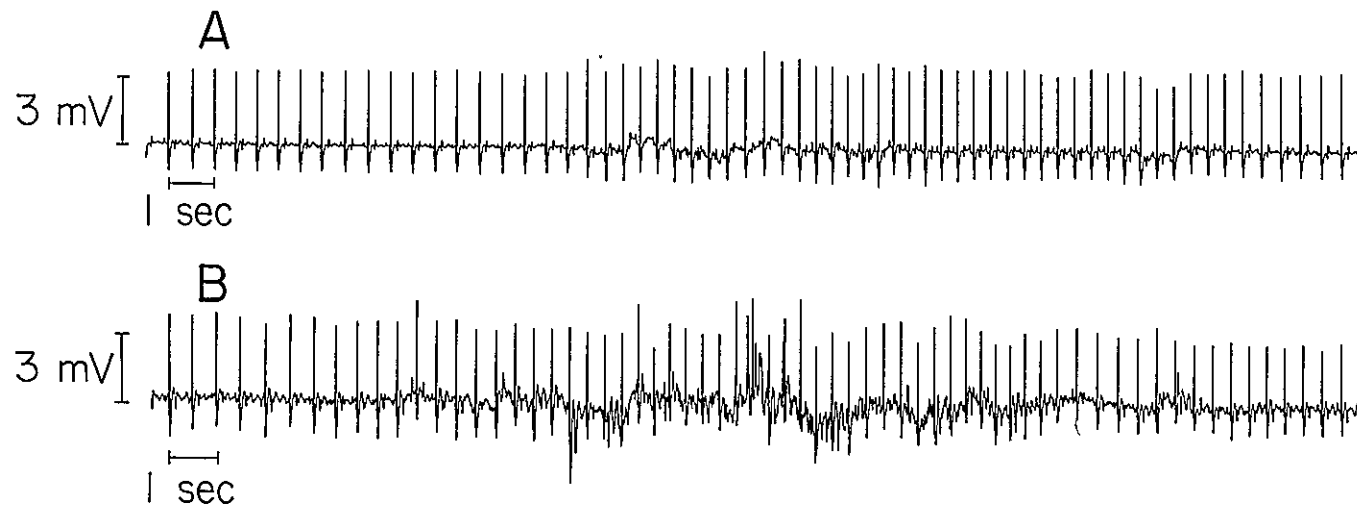

Figure 4.- Activity ECG records from different electrodes implanted in a dog.

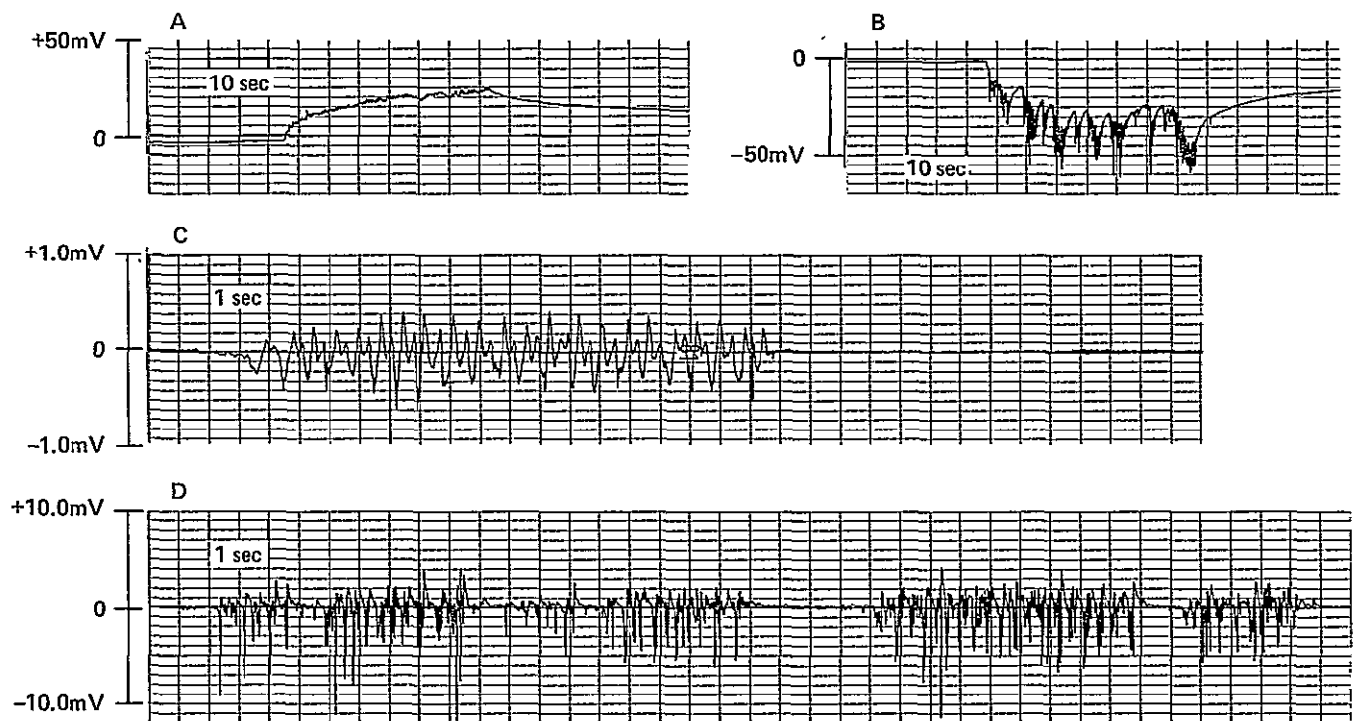

Figure 5.- Disturbance artifact susceptibility of different electrodes in vitro.

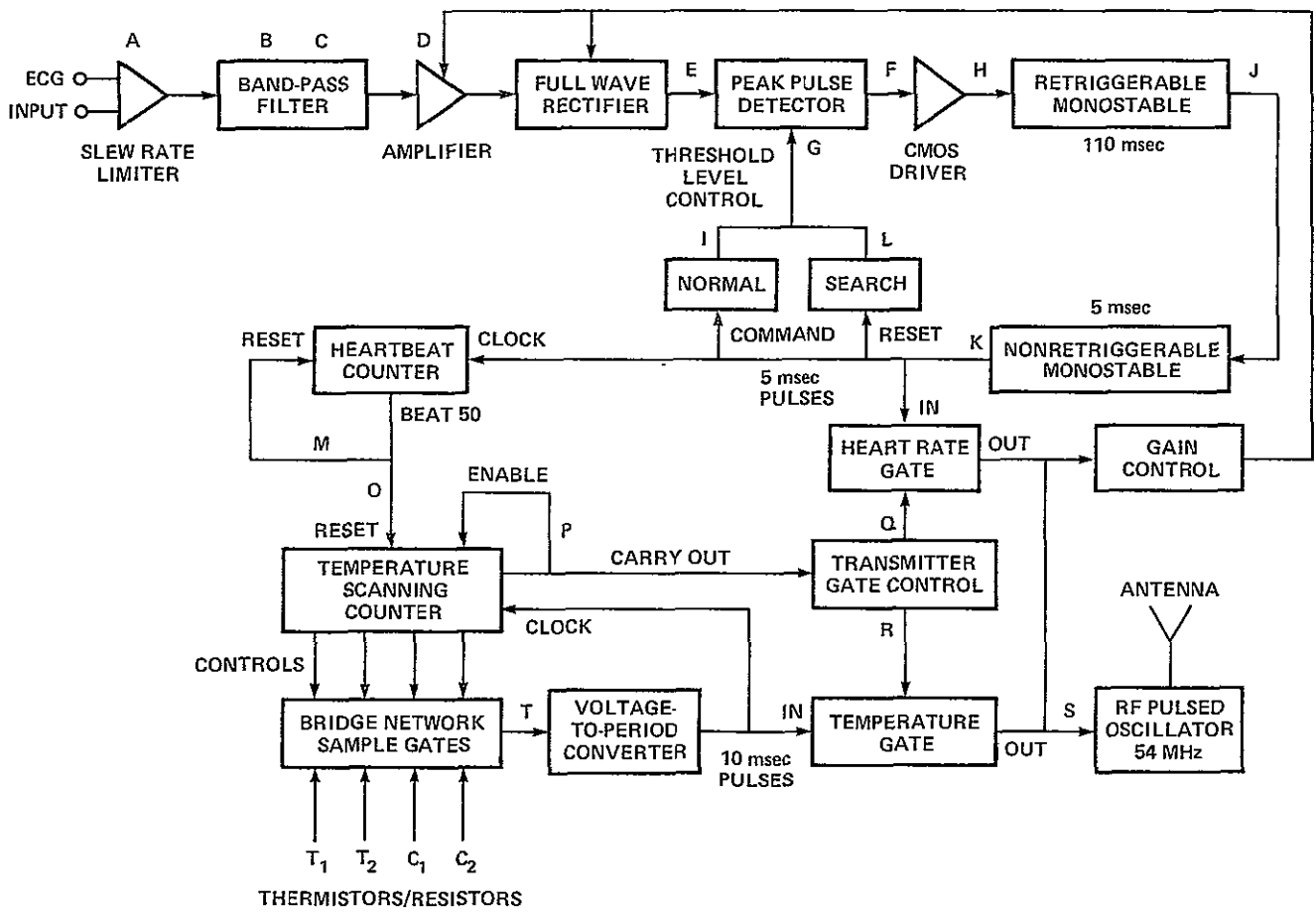
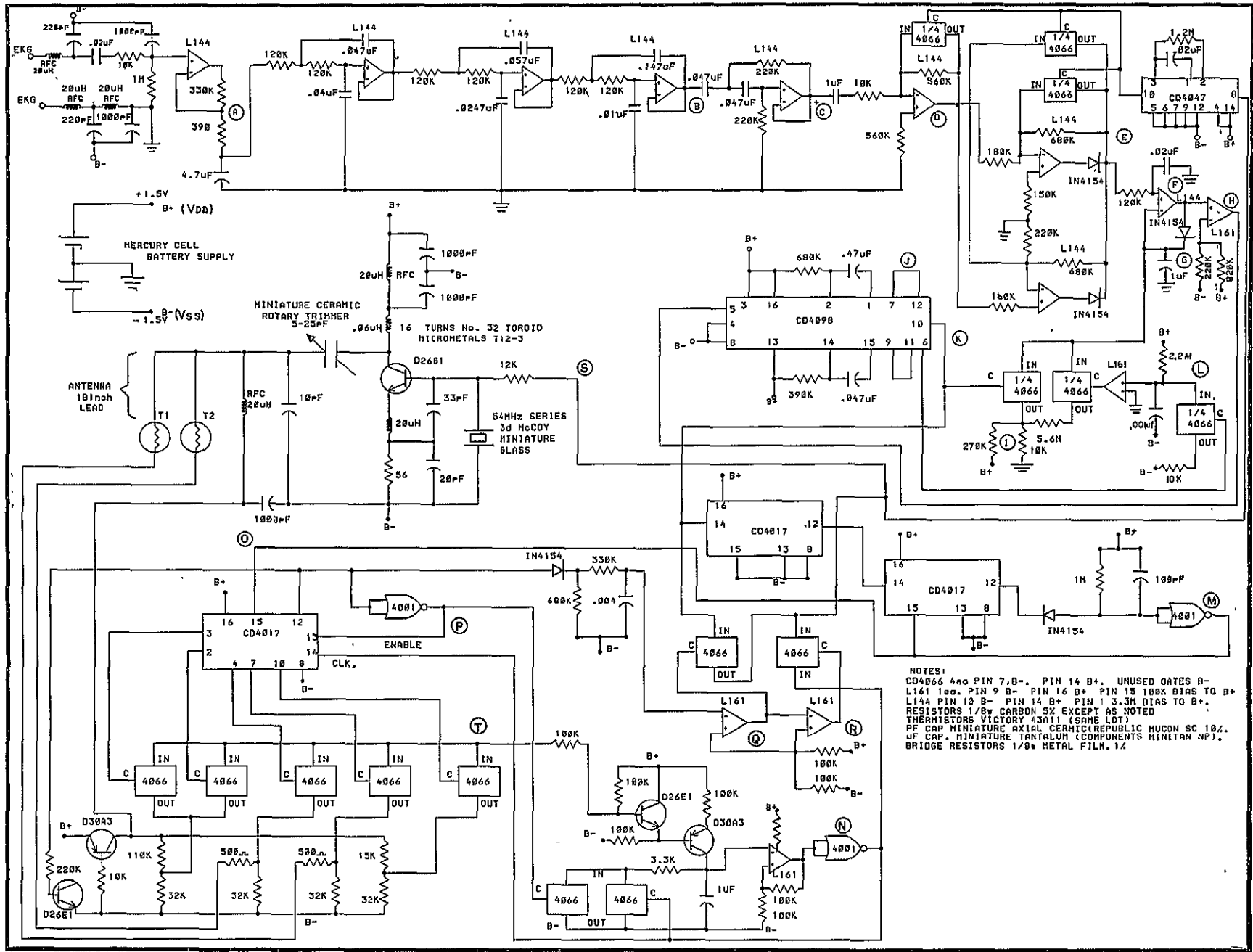

Figure 6.- Block diagram of implantable transmitter.



NOTES:
 CD4066 400 PIN 7, B-. PIN 14 B+. UNUSED GATES B-
 L161 100. PIN 9 B- PIN 16 B+ PIN 13 100K BIAS TO B+
 L144 PIN 10 B- PIN 14 B+ PIN 1 3.3M BIAS TO B+
 RESISTORS 1/8W CARBON SX EXCEPT AS NOTED
 THERMISTORS VICTORY 43A11 (SAME LDT)
 PF CAP MINIATURE AXIAL CERAMIC (REPUBLIC HUCON SC 10%
 uF CAP. MINIATURE TANTALUM (COMPONENTS MINITAN NP).
 BRIDGE RESISTORS 1/8W METAL FILM. 1%

Figure 7.- Circuit diagram of implantable transmitter.

A ECG, B LOW-PASS FILTERED ECG, C HIGH-PASS FILTERED ECG, D AMPLIFIED ECG,
 I SETS MINIMUM TRIGGER LEVEL (270K, 10K), NORMAL THRESHOLD ADJUST (10K), SEARCH
 MODE-TRACKING RATE (5.6M), L SETS START OF SEARCH MODE (2.2M)

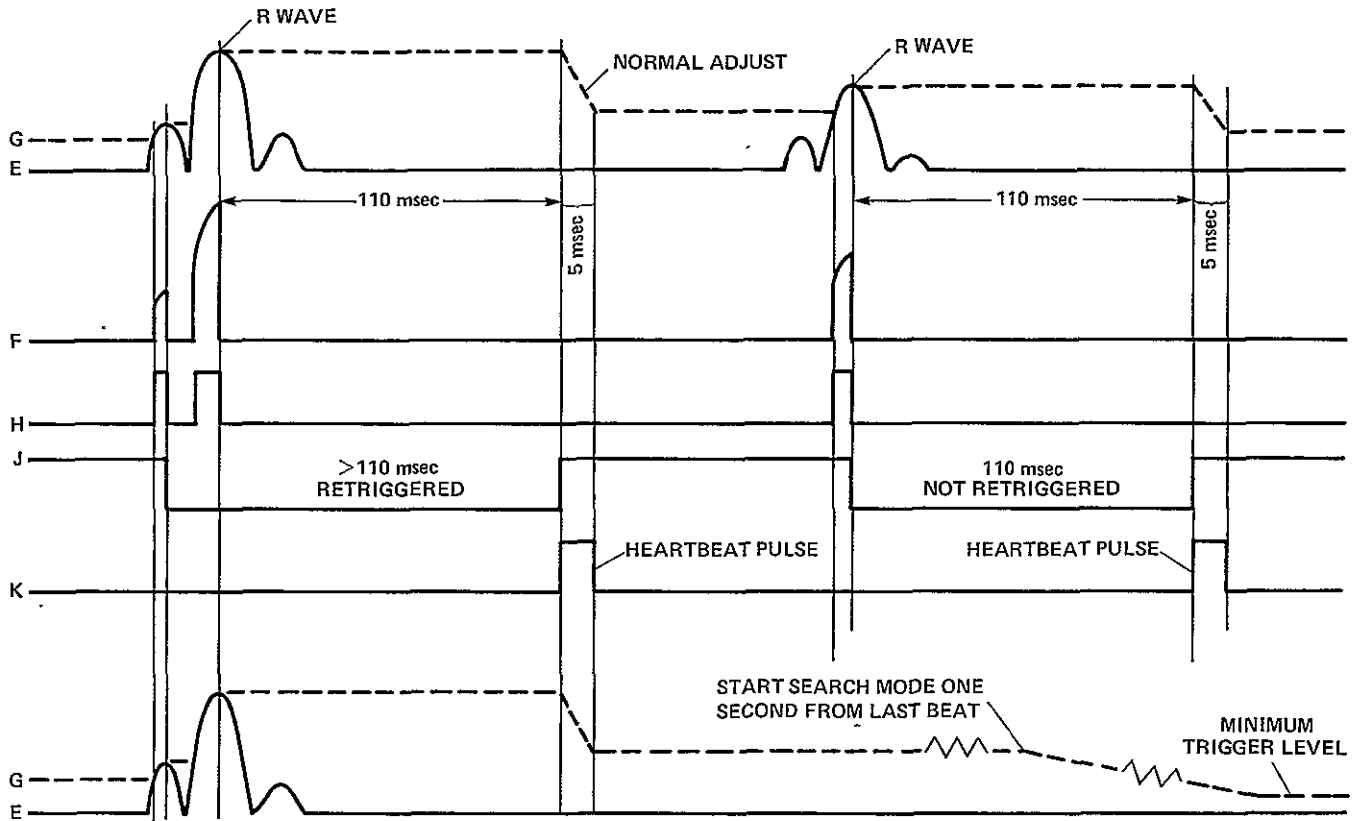

Figure 8.- R-wave detector stage functions for threshold control.

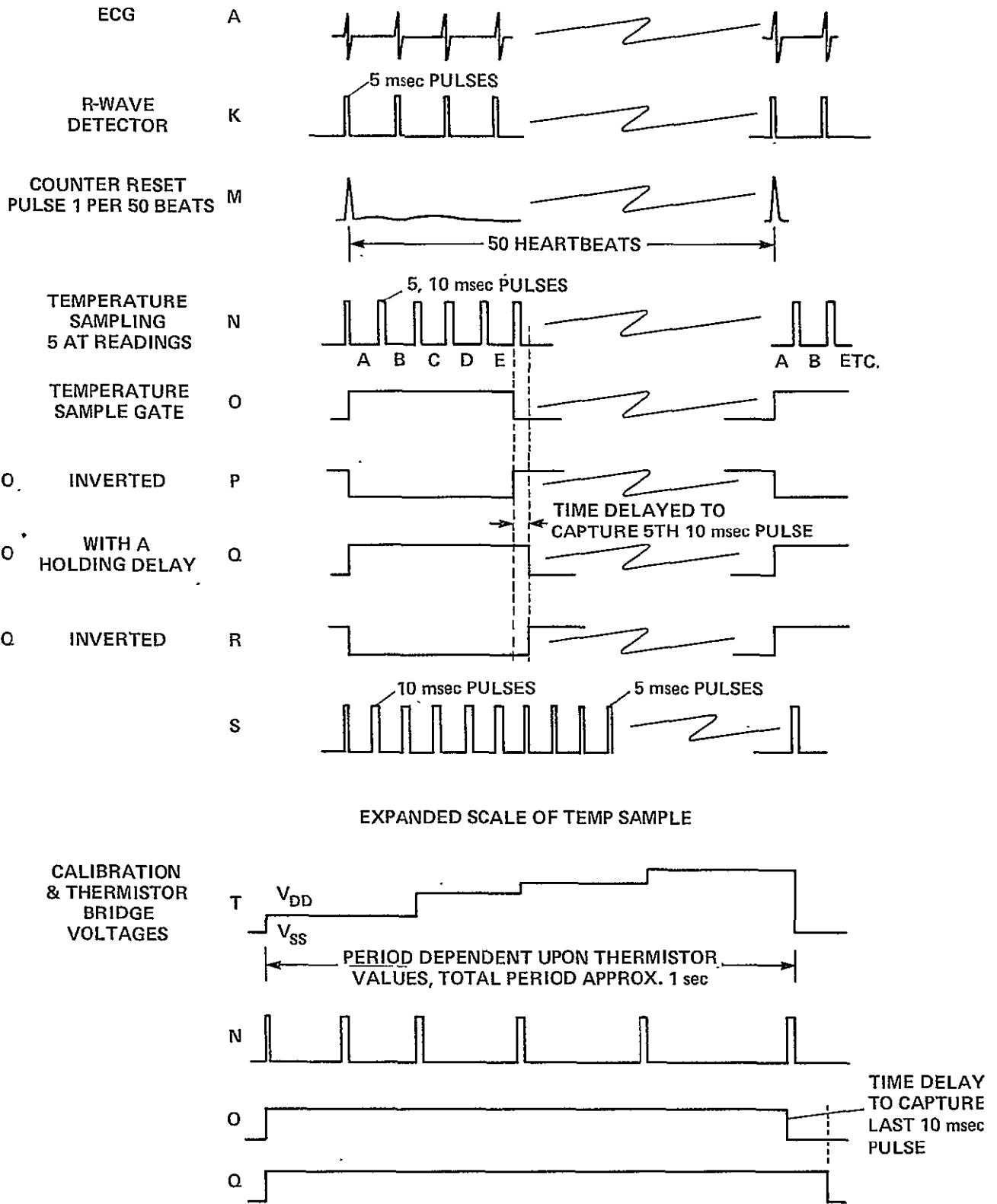

Figure 9.- Temperature waveforms for circuit modulation.

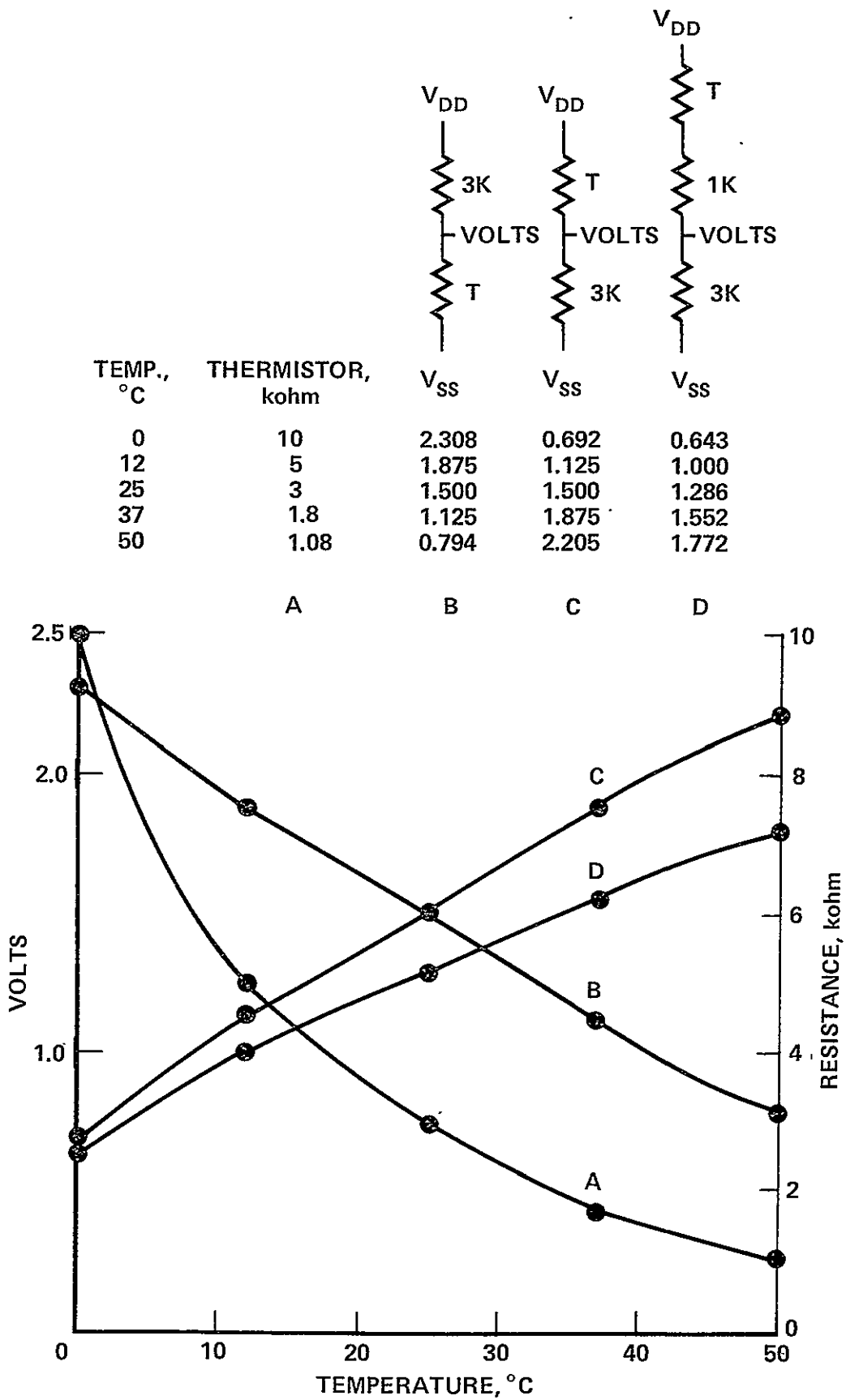

Figure 10.- Thermistor bridge outputs.

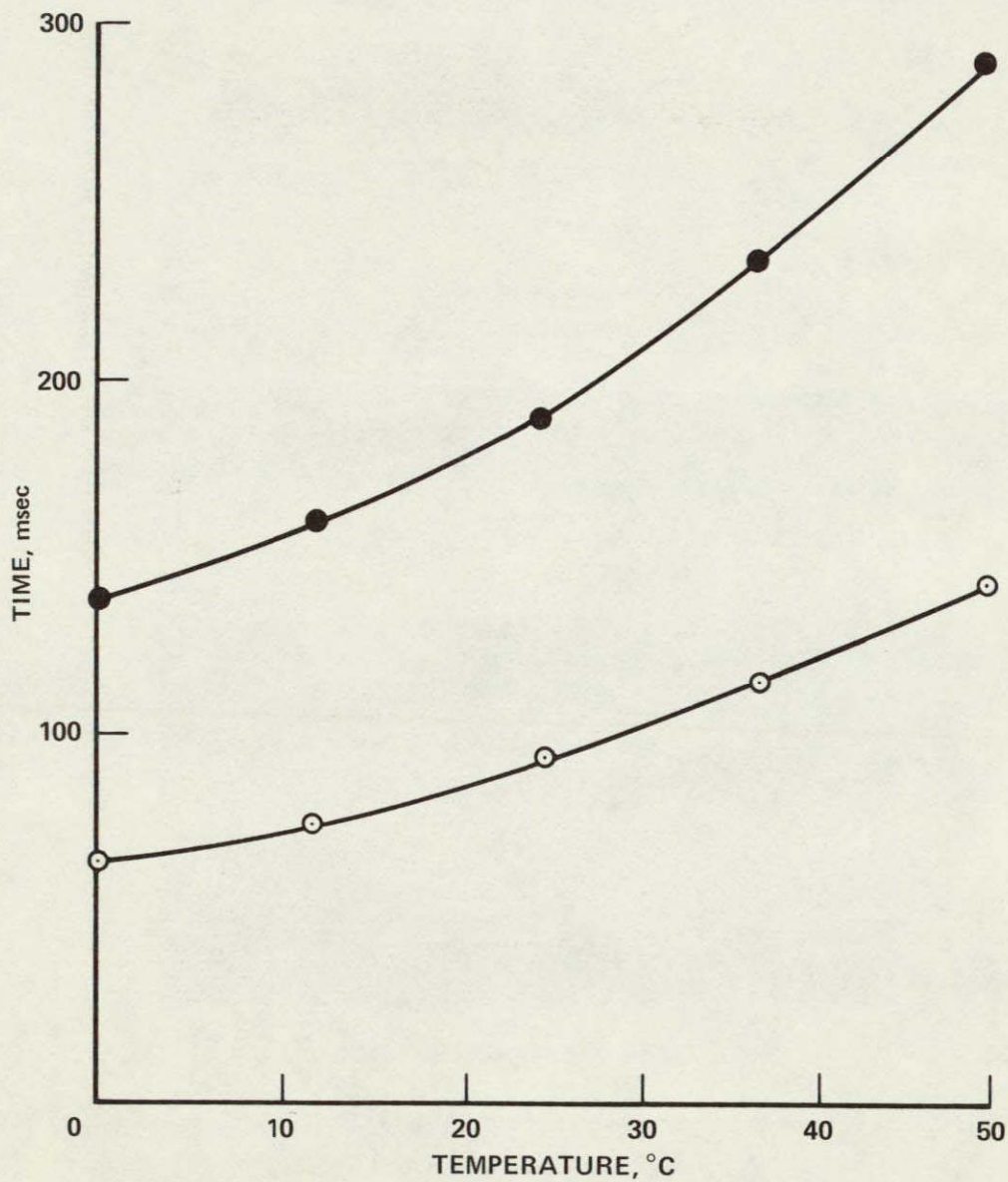
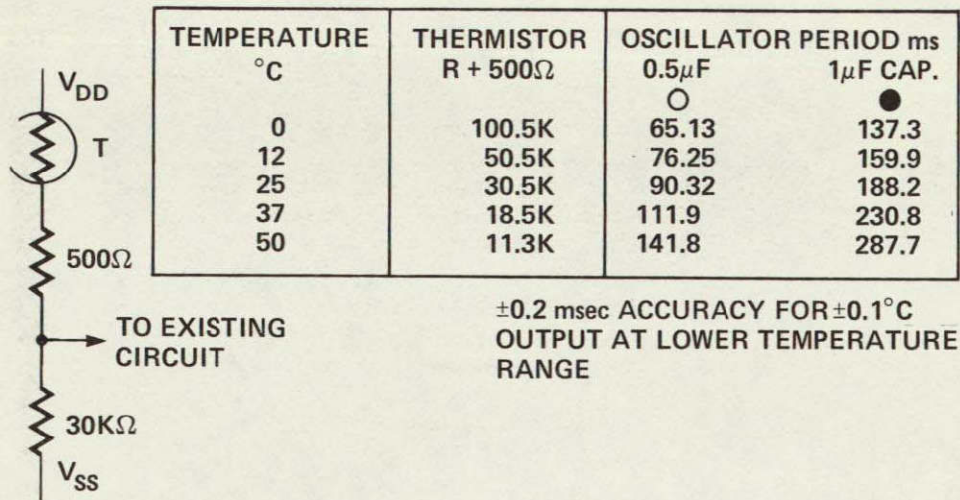

Figure 11.- Thermistor bridge calibrations.

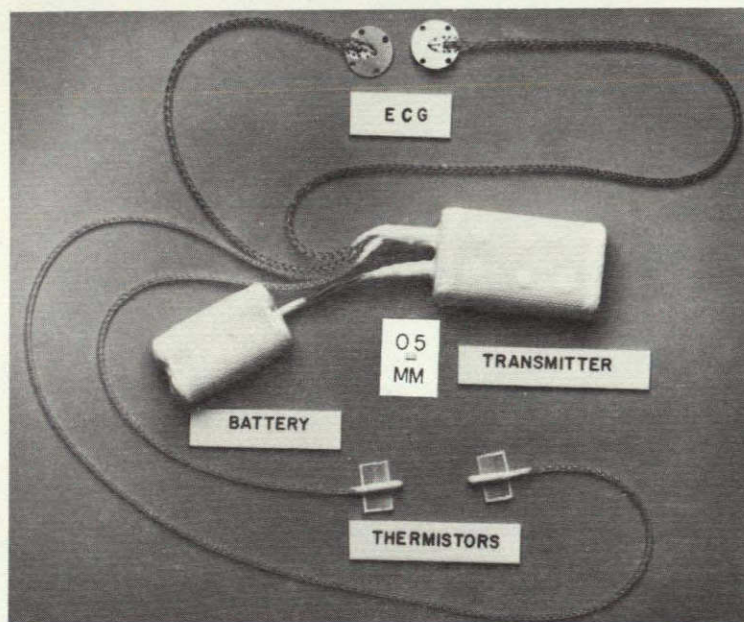
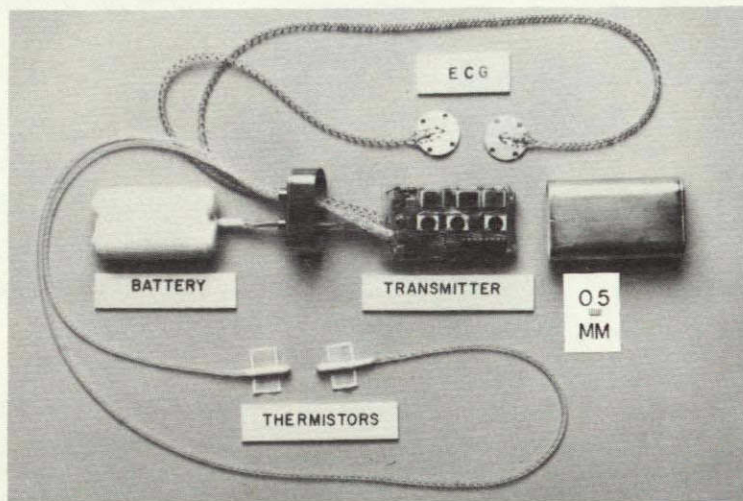
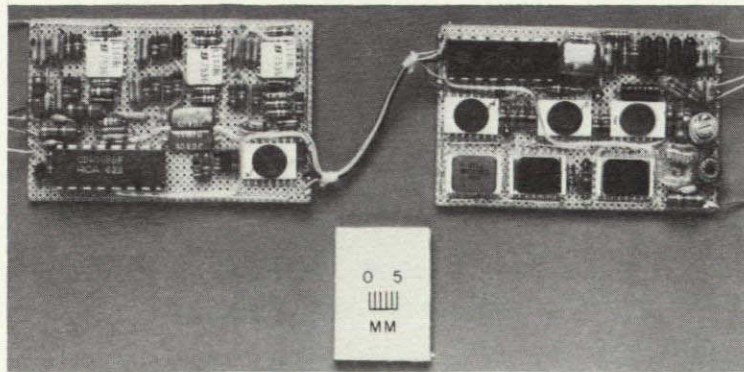

Figure 12.- Transmitter at various stages of prototype packaging.

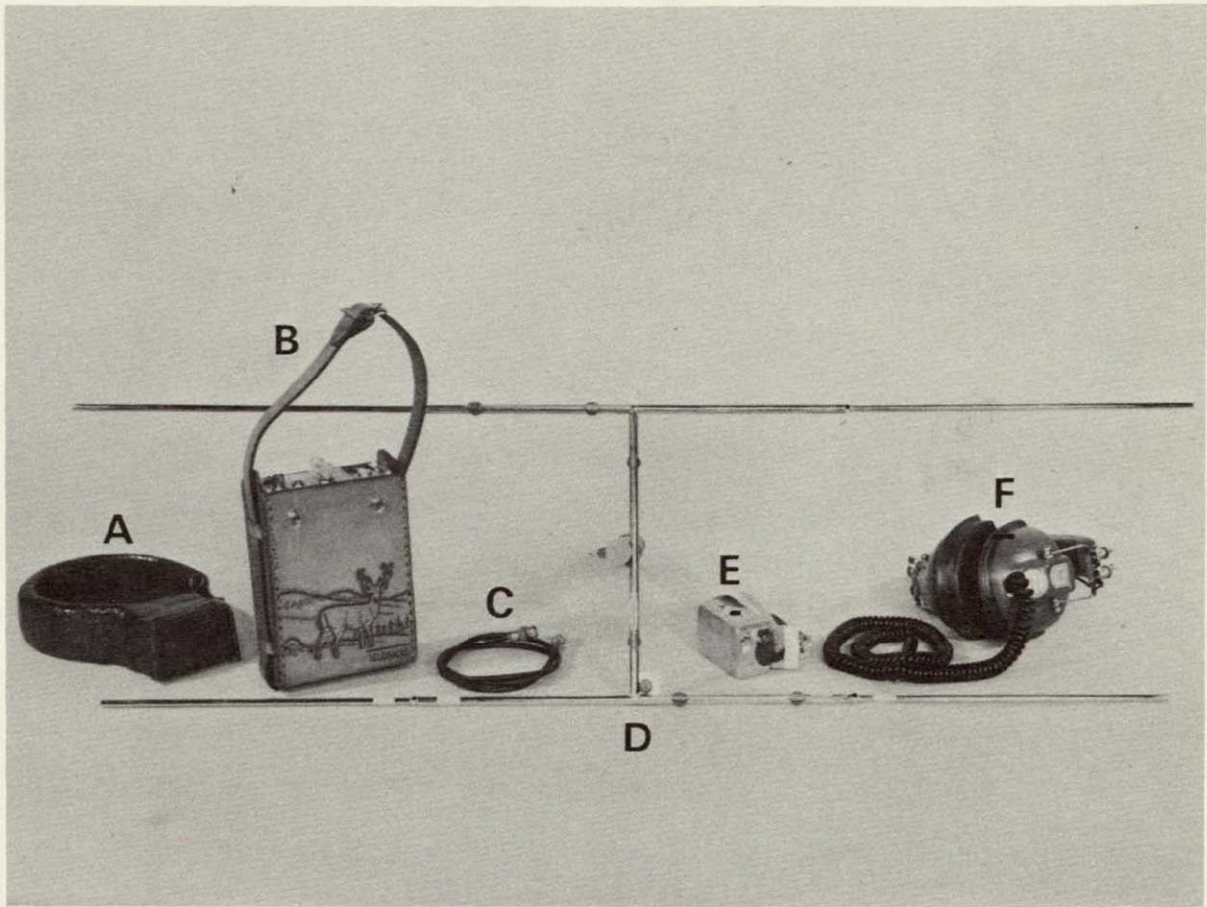
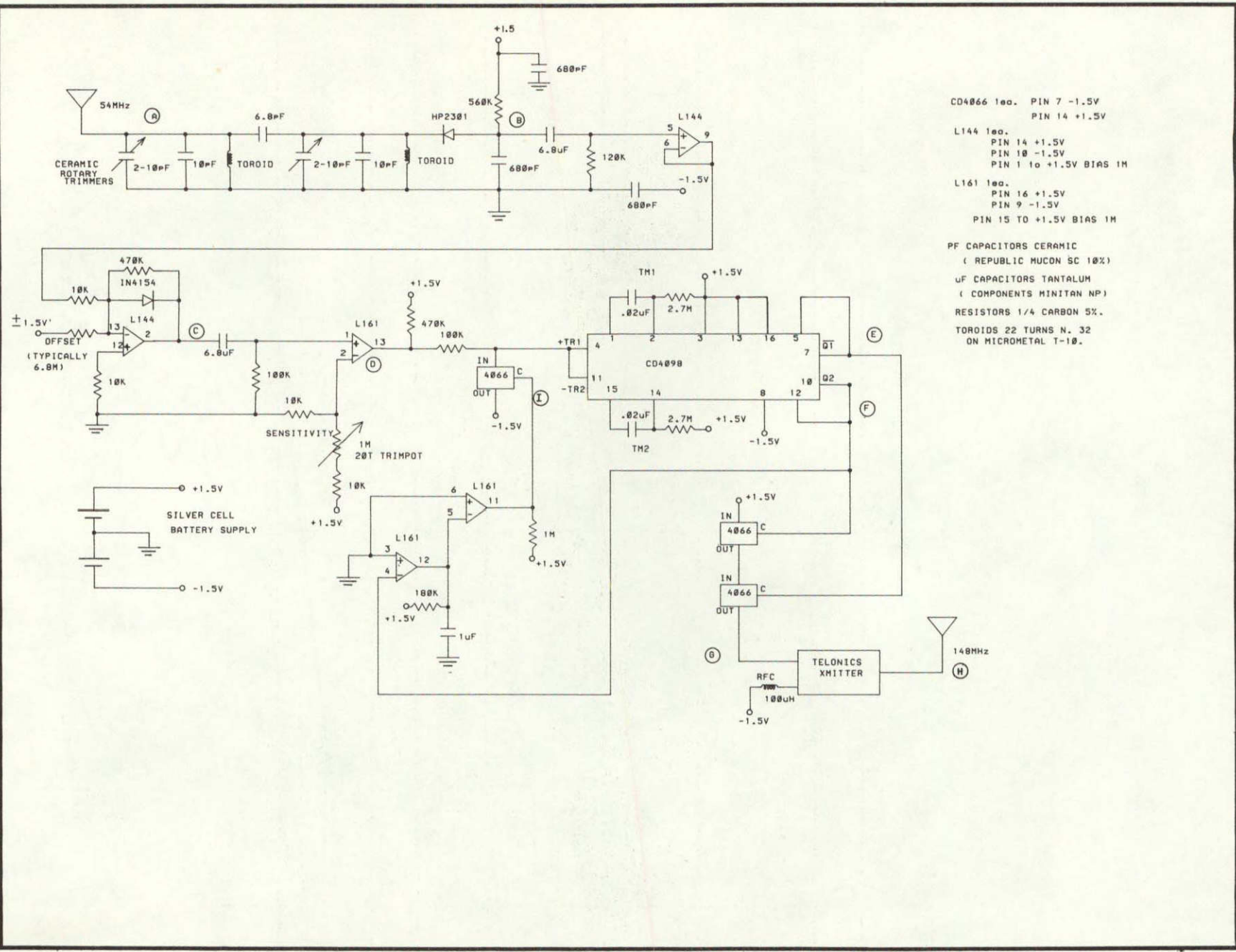

Figure 13.- Collar prototype and field receiver equipment.

ORIGINAL PAGE IS
OF POOR QUALITY



- CD4066 1ea. PIN 7 -1.5V
PIN 14 +1.5V
- L144 1ea.
PIN 14 +1.5V
PIN 10 -1.5V
PIN 1 to +1.5V BIAS 1M
- L161 1ea.
PIN 16 +1.5V
PIN 9 -1.5V
PIN 15 TO +1.5V BIAS 1M
- PF CAPACITORS CERAMIC
(REPUBLIC MUCON SC 10%)
- UF CAPACITORS TANTALUM
(COMPONENTS MINITAN NP)
- RESISTORS 1/4 CARBON 5%.
- TORIODS 22 TURNS N. 32
ON MICROMETAL T-10.

A

Figure 14.- Collar transceiver circuit diagram.

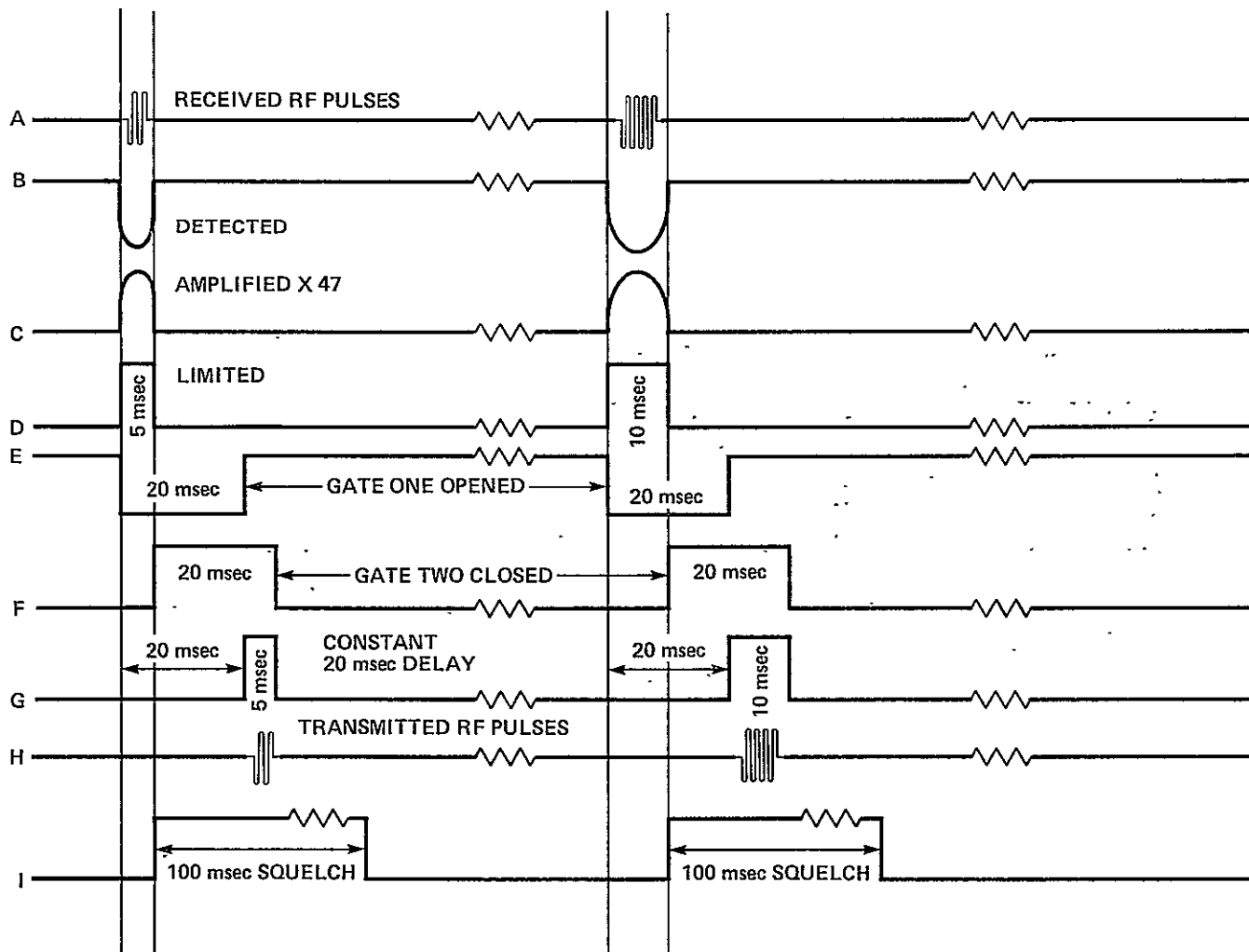

Figure 15.- Collar transceiver timing diagram.

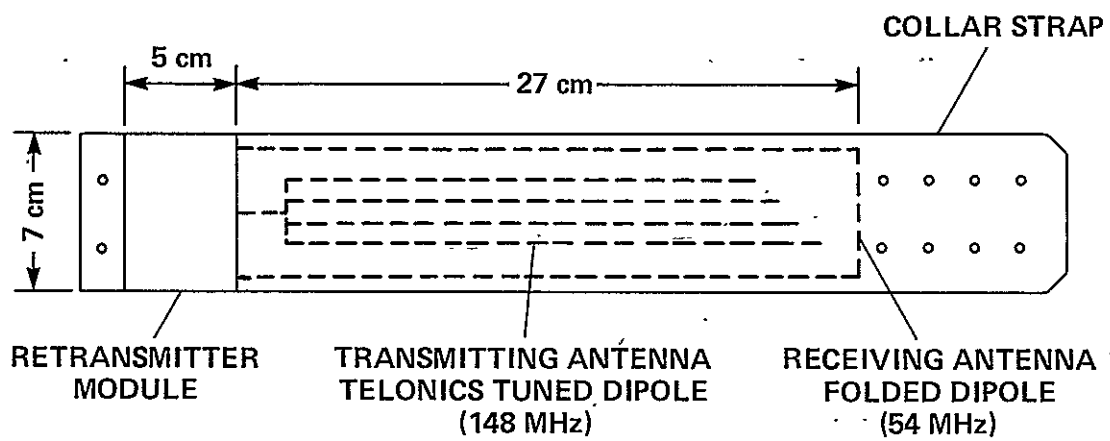

Figure 16.- Collar antenna arrangement.

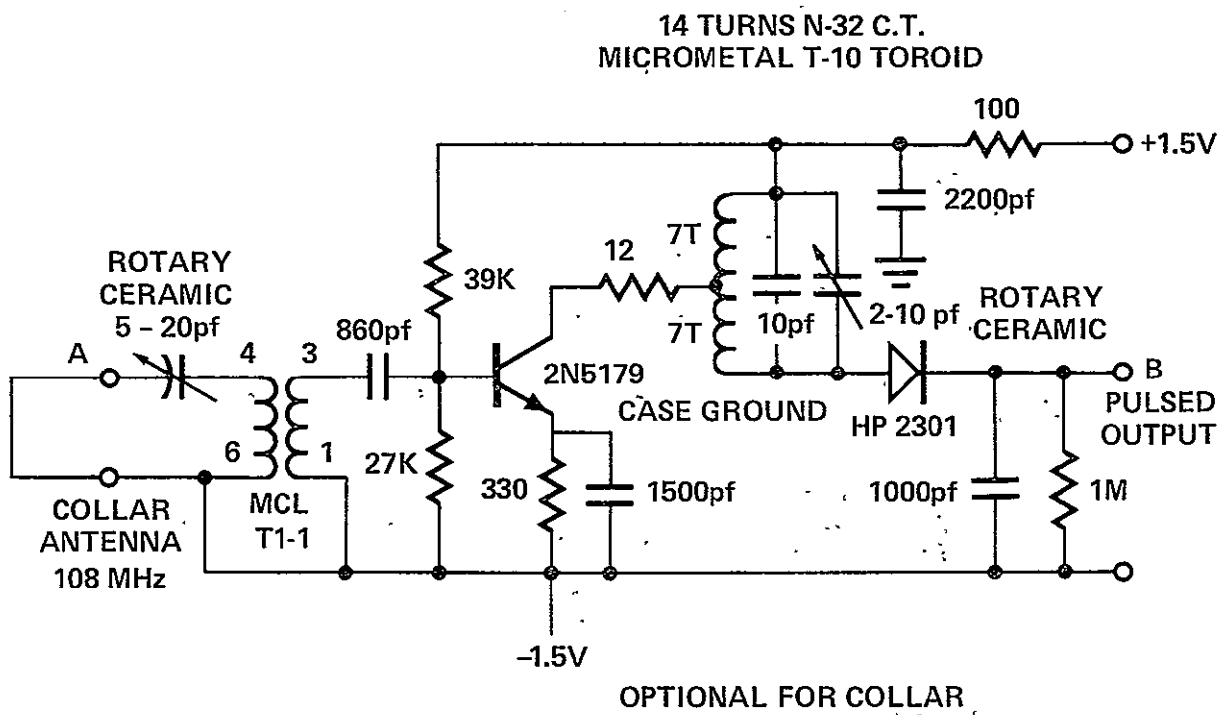

Figure 17.- Circuit diagram for active gain stage.

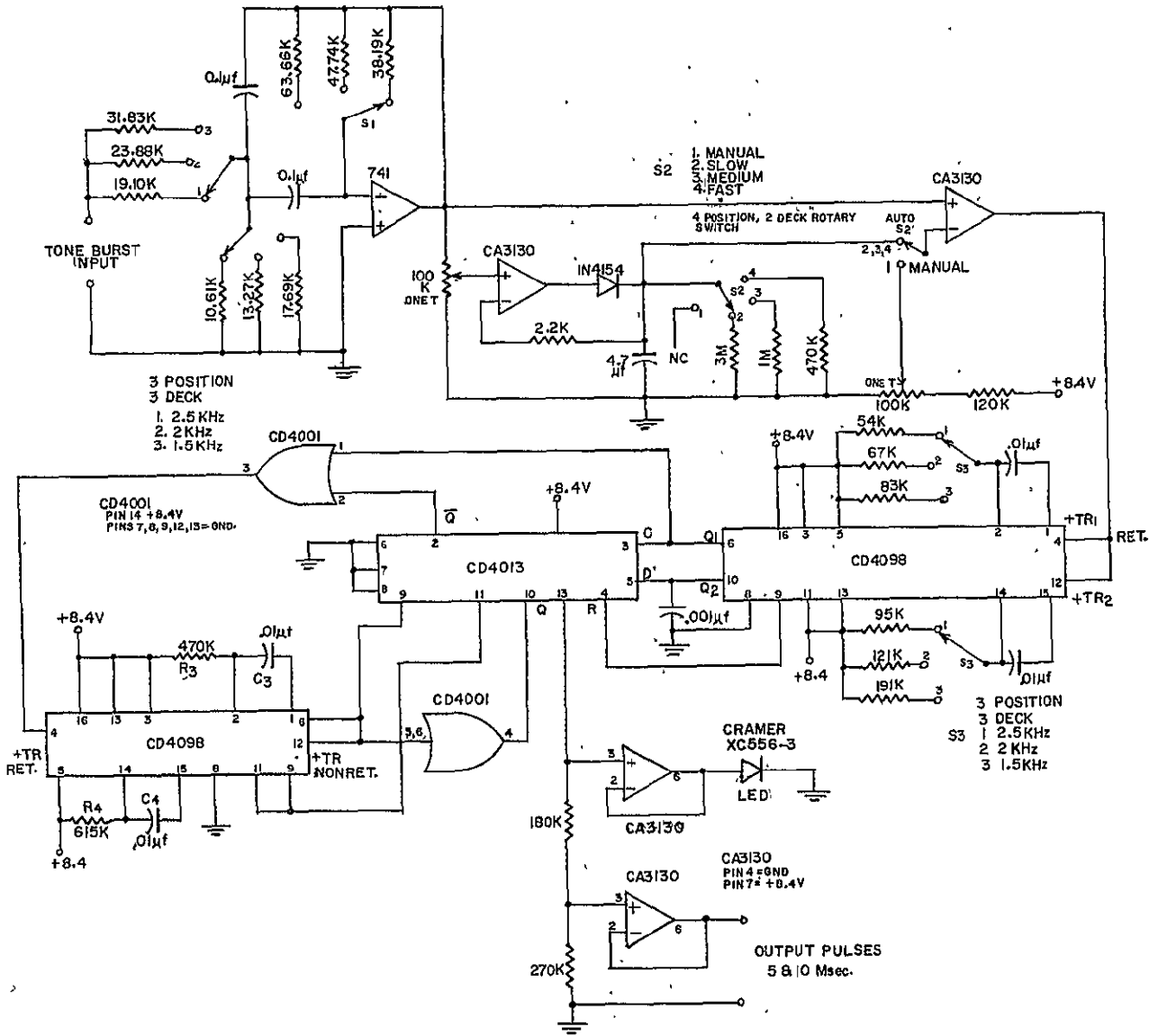

Figure 18.- Interface circuit diagram.

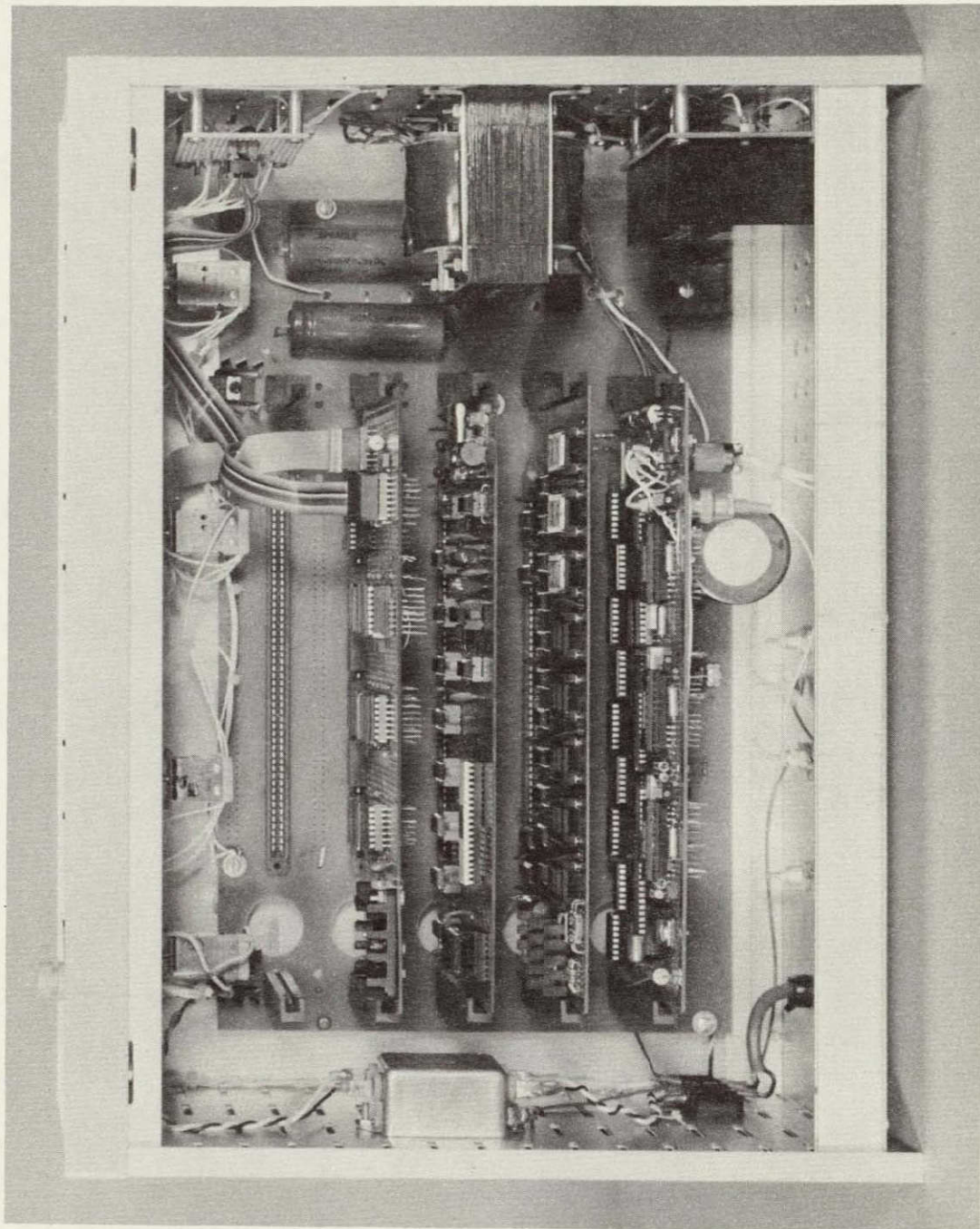

Figure 19.- Top view of demodulator.

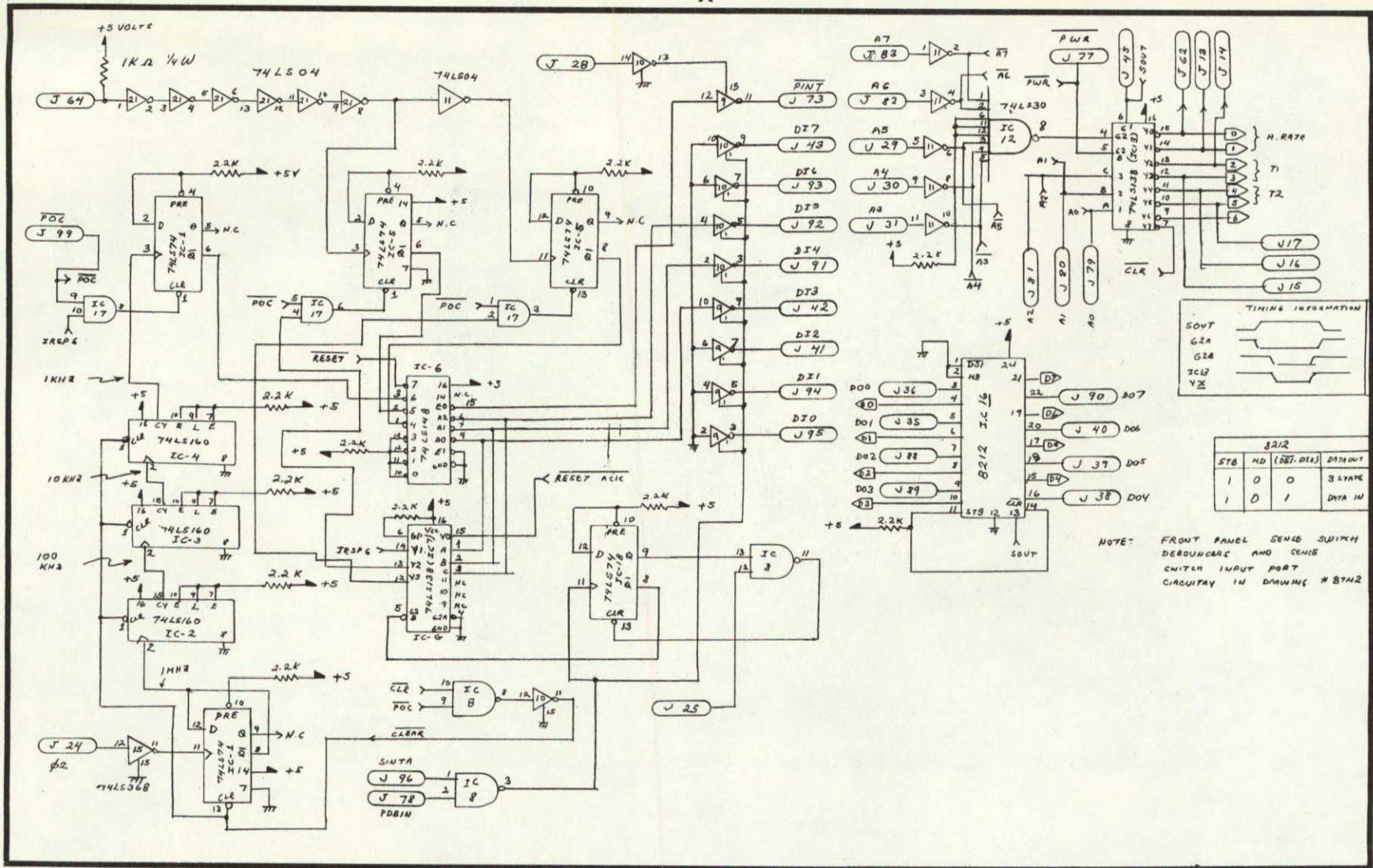

Figure 20.- Circuit diagram of demodulator.

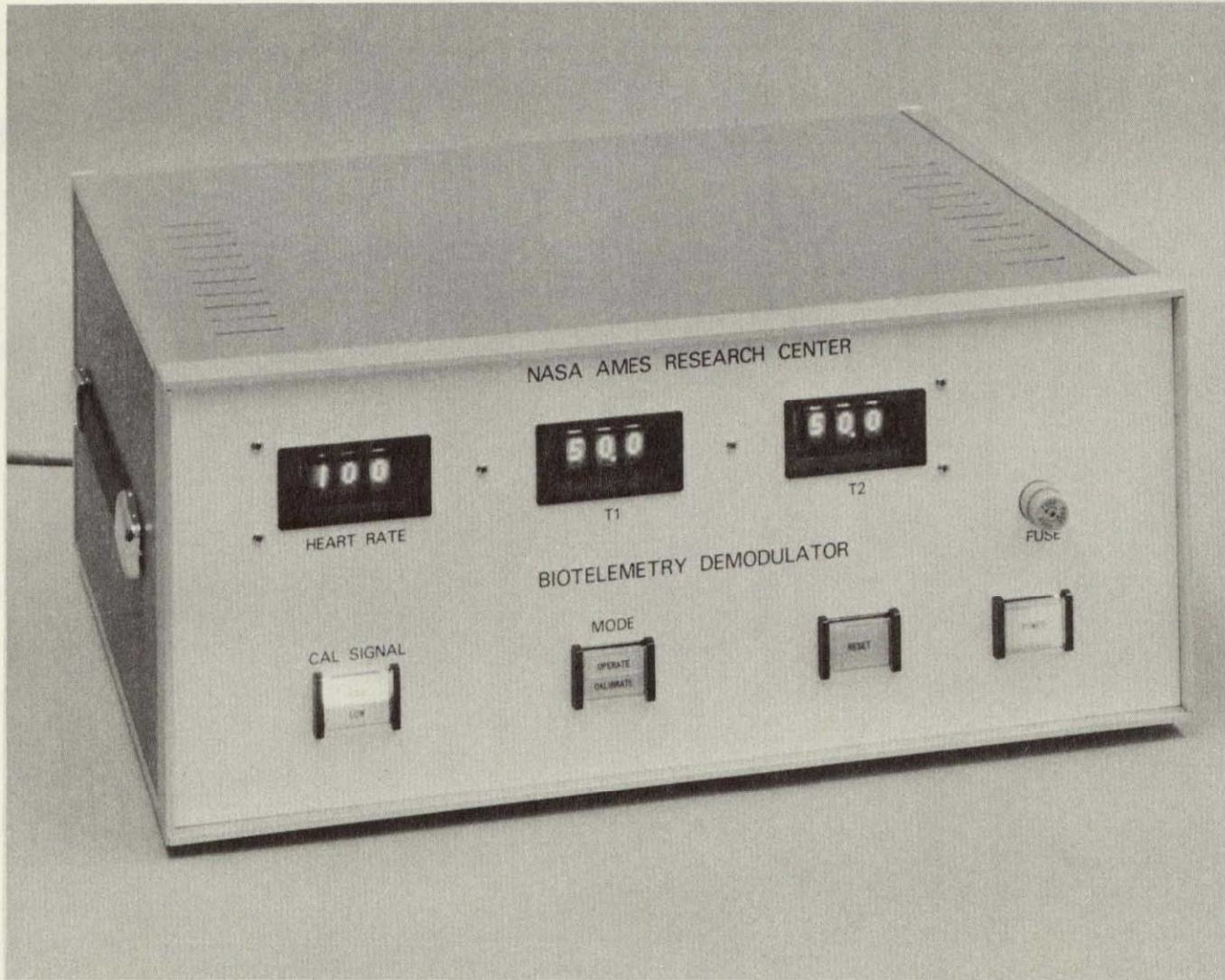

Figure 21.- Front panel of demodulator.

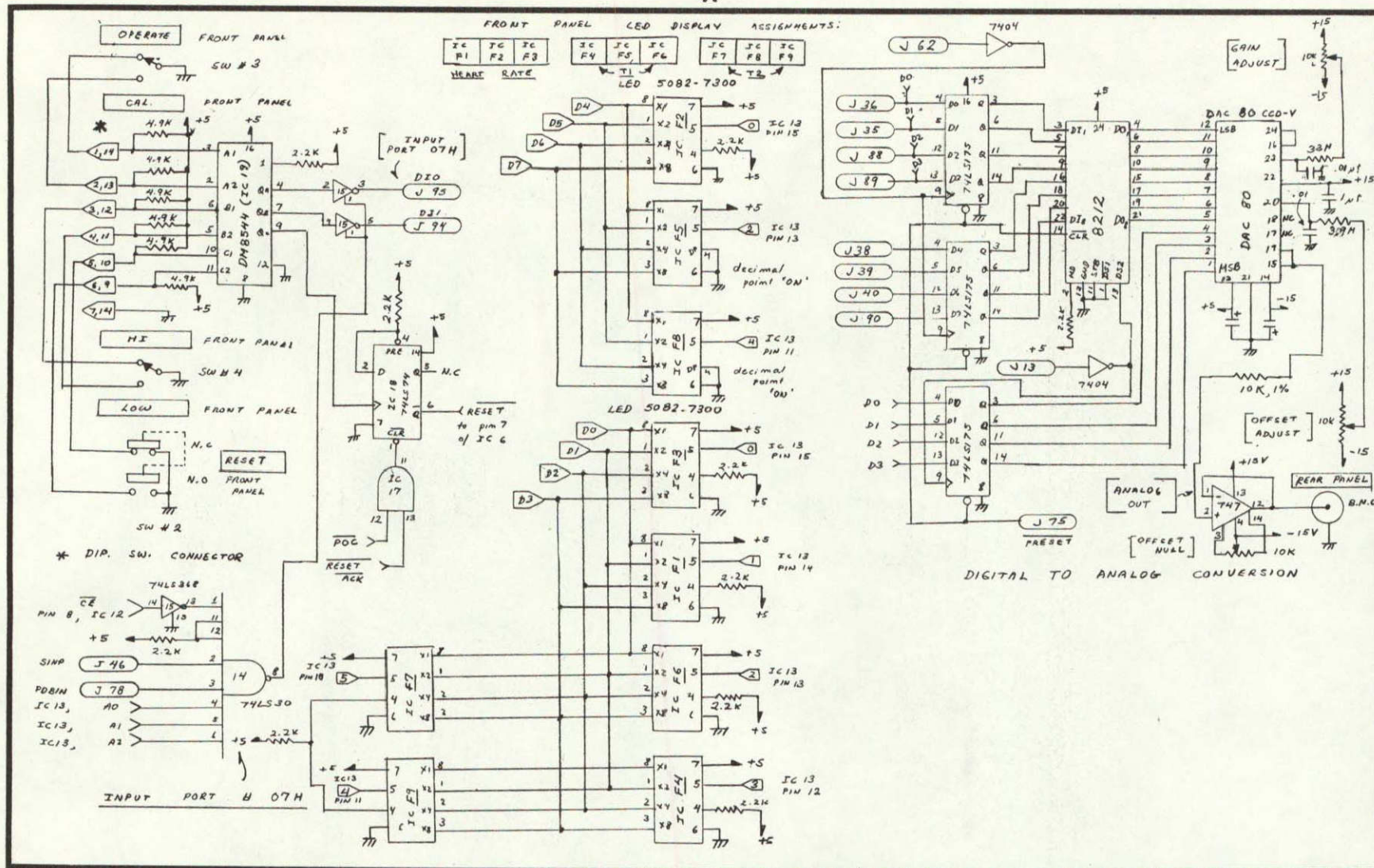

Figure 22.- Continued circuit diagrams of the demodulator.

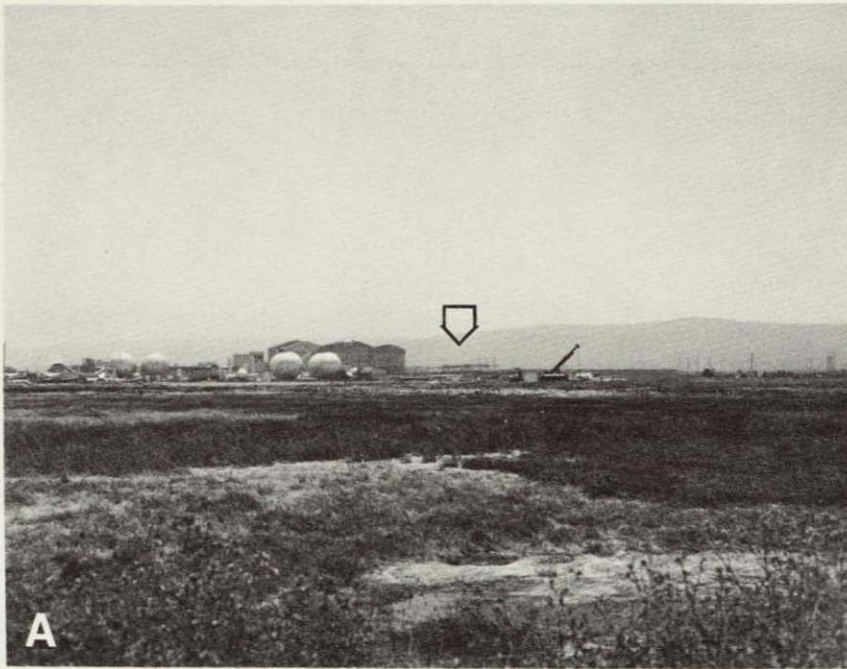

Figure 23.- Views of field test station.

ORIGINAL PAGE IS
OF POOR QUALITY

1. Report No. NASA TM-78590		2. Government Accession No.		3. Recipient's Catalog No.	
4. Title and Subtitle A LONG-RANGE AND LONG-LIFE TELEMETRY DATA-ACQUISITION SYSTEM FOR HEART RATE AND MULTIPLE BODY TEMPERATURES FROM FREE-RANGING ANIMALS				5. Report Date	
				6. Performing Organization Code	
7. Author(s) Gordon F. Lund,* Richard M. Westbrook, Thomas B. Fryer, and Rafael F. Miranda				8. Performing Organization Report No. A-7824	
				10. Work Unit No. 199-71-02	
9 Performing Organization Name and Address NASA Ames Research Center Moffett Field, Calif. 94035				11. Contract or Grant No. NSG 2293	
				13. Type of Report and Period Covered Technical Memorandum	
12. Sponsoring Agency Name and Address National Aeronautics and Space Administration Washington, D.C. 20546				14. Sponsoring Agency Code	
15. Supplementary Notes *National Research Council Associate, Adj. Assoc. Prof., San Jose State Univ., San Jose, CA					
16. Abstract A long-range and long-life telemetry system for heart rate and multiple body temperatures from free-ranging animals has been designed. This system includes an implantable transmitter, external receiver-retransmitter collar, and a microprocessor-controlled demodulator. The size of the implant is suitable for animals with body weights of a few kilograms or more; further size reduction of the implant is possible. The ECG is sensed by electrodes designed for internal telemetry and to reduce movement artifacts. The R-wave characteristics are then specifically selected to trigger a short radio frequency (RF) pulse. Temperatures are sensed at desired locations by thermistors and then, based on a heartbeat counter, transmitted intermittently via pulse interval modulation. This modulation scheme includes first and last calibration intervals for a reference by ratios with the temperature intervals to achieve good accuracy even over long periods. Pulse duration and pulse sequencing are used to discriminate between heart rate and temperature pulses as well as RF interference. The implanted transmitter might be used alone for experiments on animals that frequent particular locations within a large territory; on animals in virtually any laboratory situation; or on animals in moderate-sized enclosures, such as those in a zoological garden. The implanted transmitter is otherwise interfaced with the receiver-retransmitter collar that employs commercial tracking equipment to achieve the long-range transmission. Peak energy is consumed only during the short RF pulses so that average current drain of either transmitter is in the range of tenths of milliamperes. The RF pulses from either transmitter are processed by the microprocessor controlled demodulator for the characteristics of pulse durations, intervals, and sequence. The output provides analog beat-to-beat heart rate and periodically updated temperatures as well as digital display. Heart rates to several hundred beats per minute (BPM) and body temperatures within a range of zero to 50° C with 0.1° C in resolution of change or better seem feasible. The objective of the design was to achieve a high degree of experimental flexibility and overall high quality in performance. The system was tested in prototype form on a dog.					
17. Key Words (Suggested by Author(s)) Long-range telemetry Radio telemetry Heart rate Temperatures Data acquisition			18. Distribution Statement Unlimited STAR Category - 51		
19. Security Classif. (of this report) Unclassified		20. Security Classif. (of this page) Unclassified		21. No. of Pages 73	22. Price* \$4.50