

LARGE-SCALE FIBER RELEASE AND EQUIPMENT EXPOSURE EXPERIMENTS

R. A. Pride
NASA Langley Research Center

The large-scale testing is a very recent part of the risk analysis program as far as getting the field work completed. The final test was performed less than one week ago and data from all of these tests is just beginning to be available. About a year ago at the last conference (reference 1) only very preliminary plans for this large-scale test program could be discussed, so a lot has happened in this past year which is the basis for this paper. The large-scale testing has been accomplished with two sets of tests as shown in figure 1. Outdoor tests have been run at the U.S. Army Dugway Proving Ground, Utah which were looking both for a better definition of the source, i.e., the amount of fiber released, in a full scale fire, and also its dissemination away from the fire. In the test planning using laboratory test results as a basis, the conclusion was reached that there was almost no chance of getting a sufficient level of exposure in downwind dissemination from any kind of large-scale outdoor test that could be performed within the limits of the national budget that would have any reasonable likelihood of failing electronic equipment. Therefore, a second set of tests were designed for equipment vulnerability to fire released fibers to be run in a shock tube at the U.S. Naval Surface Weapons Center, Dahlgren, Virginia. There was a possibility that some transfer function work also might be done in the shock tube, however, as the planning and preliminary testing progressed, the effort was concentrated on vulnerability entirely.

Dahlgren Shock Tube Tests

Figure 2 is an aerial photograph of the 0.8 km long shock tube which was modified near the mid-length to burn carbon fiber composites in a jet fuel fire. The fire-released fibers, combustion products and heated air were transported through the tube by exhaust fans installed in the large end. An exposure area for equipment vulnerability testing was developed near the large end so that reasonable mixing and cooling could occur in the air stream prior to passing by the equipment under test. A water curtain filtered the carbon fibers and much of the soot out of the air before it was exhausted out of the tube.

Fifty-four fire tests were run to develop and validate a technique for getting maximum dissemination of fire-released single fibers down to the equipment exposure area for the vulnerability testing. The technique which was developed included a rotating basket (figure 3) that was suspended in the fire in such a manner that the composite material in the basket was tumbled continuously throughout the duration of the fire. The composite material was cut into strips approximately 1 to 2 cm wide by 15 to 20 cm long which were delaminated to thicknesses of about four plies of composite prior to being placed in the basket. With this technique and burning and tumbling until no composite remained in the basket, a mass of single fibers equal to 0.5 percent of the initial fiber mass was released and transported to the exposure area. As a result, in test 53, fiber exposures were obtained which

were great enough to be capable of producing equipment failures.

Figure 4 lists the principal fire test parameters for test 53 in the shock tube. A half percent fiber release was obtained, but that was because the duration of the fire was about 200 minutes; the fire was burning in a 1.2 m square fire pan with commercial jet A fuel; temperatures were controlled around the specimen basket in the range of 950 to 1,000° C. The shock tube tests were trying to simulate the fire parameters that Joe Mansfield had initially identified in the large-scale outdoor fire modelling that he was doing. The composite mass was totally consumed after 134 minutes of burning, much longer than the average aircraft accident fire. But this test was run that long in order to get the maximum dissemination of fibers down the tube. At the exposure area, the fibers were all carried by air being moved through the tube; the plume was constrained by the inside walls of the tube and could not expand the way it would normally. Measured air velocities were about 0.7 m/s. Air temperature moving past the equipment was about 30° C - just about a five degree rise over ambient which was well within operational temperature limits for the equipment.

The amount of fibers being disseminated in this particular test was measured by various types of instrumentation (figure 5). Sticky papers were used both laid flat for fiber deposition and in the form of sticky cylinders which provide a measure of exposure. Fibers were collected with a Peterson aerodynamic sampler which will be discussed later in more detail in connection with the Dugway tests. The high voltage grid was described by Taback in the Equipment Vulnerability paper (ref. 2). A light-emitting detector (LED) was one of the instruments that was modified for use at Dugway from an earlier design used at China Lake last year (ref. 3). The modified design was operated in the shock tube for a check on its ability to sense fibers in a sooty atmosphere. Two NIOSH Millipore filters were injected into the airstream for short periods of time to sample that environment for the possibility of short fibers. A total of 228 instrumentation pieces were operated to detect carbon fibers.

Figure 6 presents some of the results from that instrumentation for the sticky papers. The buildup in fiber exposure as determined from the sticky cylinders is plotted as a function of composite burn time. Each set of cylinders was inserted in the tube for a 15 minute interval and then removed and a new set was inserted. Fibers collected on these cylinders gave an indication on an incremental basis of the buildup in fiber exposure with burn time that can be seen to be approximately linear up to a value of about 8×10^5 fiber-s/m³. This is much greater than the exposure obtained from sampling by sticky cylinders that were in the entire time (continuous). This is an indication that the environment was probably saturating these continuous samplers and, therefore, a low count of exposure was obtained. The horizontal surface deposition stickies located on the floor of the tube indicated a much greater exposure at the end of the test than either form of sticky cylinder. This also would indicate a saturation of both forms of sticky cylinder instrumentation.

A similar plot of fiber exposure is shown in figure 7 for the high voltage grid, which because of its ability to sense fiber hits in real time is able to

provide a measure of exposure with time. Again a linear rate of fiber release is observed with the only difference from the previous data being exposures three times as great at the end of test as from any of the stickies. A verification of exposure from the high voltage grid is provided by the cumulative sample that was collected in the Peterson sampler and was not subject to saturation. A good correlation is shown at the 150 minute end point. Peak exposures on the order of 10^7 fiber-s/m³ were determined at the end of the test.

Figure 8 shows the fiber length distribution that came out of this test. Fibers collected in the Peterson sampler were sized for length and the results are shown by the solid bars. Fibers were sized on the sticky papers and they're shown by the dashed bars. An exponential expression was fitted to this data and the agreement appears reasonable except at the short fiber lengths less than 1.5 mm where the sampler collection efficiency becomes poor. The average fiber length for fibers that are greater than one millimeter in length (the ones that are of interest for vulnerability) is two millimeters in this test.

Six Dynaco amplifiers were installed in the shock tube and exposed to the same environment as the various sampler instruments. Figure 9 is a plot of their failure occurrences with burn time. Four failed in the first ten minutes, then exposure continued for another fifteen minutes to about twenty-five minutes total before the next one failed and finally the last one failed at about forty minutes total exposure. The total composite burn time was on the order of 150 minutes so failures of these amplifiers occurred in less than half of the time required to get the composite completely disseminated. If the time axis is changed to fiber exposure using figure 7 data, and if the failure scale is non-dimensionalized in terms of probability of failure, the results are shown in figure 10. The experimental data, just like it was before but now in terms of fiber exposure, show all units fail in an exposure of slightly less than 4×10^6 fiber-s/m³. These failure data can be fitted very nicely with a probability of failure calculation based on chamber test parameters as described in reference 2.

Dugway Outdoor Tests

Figure 11 presents the kinds of test parameters that were used in the design of the outdoor fire tests conducted at Dugway Proving Ground, Utah. The size and duration of the fire and the quantity of fuel burned, were basically sized by examining what seemed to be representative in commercial aircraft accidents of the fuel-fed fires occurring in this country over the last ten years (ref. 4). Forty-five kg or more of composite material was burned in each fire. This was made up of carbon-epoxy aircraft components that were supplied by the commercial aircraft manufacturers from test programs and also by two military aircraft companies. These are all components that are representative of the state of the art today in carbon-fiber-epoxy composite components. Several of them were actual flight components. The bulk of them, though, came out of technology test programs. The weather conditions specified were quite different for the two types of tests that were to be run. For one group called "source tests" the wind speed was essentially zero. A second group

which are called "dissemination tests" required winds that range upwards to about five meters per second or about ten miles an hour and a very restricted wind direction of 320 degrees plus or minus 35. There is a reasonable probability of waiting for up to a month to get this kind of a wind direction coupled with this kind of a wind velocity. This program was extremely fortunate in weather which permitted three tests in less than two weeks time.

A major consideration in the design of the outdoor tests was the kind of instrumentation that could be used at Dugway. One of the concerns was to be able to sample in the plume above the fire as many times and as independently as possible to obtain a good representation of what was being given off from burning the composite in the large outdoor fire. Figure 12 lists an overview of all of the instrumentation. The Peterson samplers were a development that came out of this program designed to sample close in to the fire, but still in the plume above it. They operated in an environment very close to the end of the visible flame in the plume. A vertical array of stainless steel mesh-covered cans was also fabricated. Both of these instruments were supported off towers that are close to the fire. Next was a separate system of six sampling types flown from a large net that was supported by balloons and which sampled the plume downwind from the fire. And, finally, there was the ground-supported instrumentation representing four types of instruments whose locations ranged all the way from 91 meters to 19,000 meters downwind from the fire. These were instruments that were basically mounted on posts about a half meter above the surface of the ground. The total amount of instrumentation involved is in excess of 2,000 instruments for each of these tests.

Figure 13 shows in detail the location of the tower-supported instrumentation. The test site development started by building two fire pools, 10.7 m in diameter. The first fire pool was in the center of the array for fires which would be burned for the source tests with zero wind where the plume would rise straight up. The second fire pool was on the upwind side of the array for dissemination fires where the wind was going to be blowing and disseminating fibers from the cloud in the design direction. Four towers 60 m high were erected from which a steel cable network was suspended. The array of 61 Peterson samplers were hung from the steel cables in a pattern designed to sample the fire plume. This array could be raised or lowered by winches at each of the towers so the samplers could be serviced, and so that it could be positioned just above the end of the visible flames for the particular test conditions. Between the two downwind towers there was a set of vertical array mesh can samplers that were designed to operate from ground level up to 53 m in the air. These provided another opportunity to intercept the plume as it was being bent over and leaving the location of the fire.

Figure 14 is a photograph of the canopy of Peterson samplers suspended from the four towers about 40 m above the ground level at sunrise on one of the particular test mornings. The vertical array is between the towers downwind in the right-hand side of the photograph. Figure 15 is a photograph of the Peterson sampler. It is a stainless steel welded cylindrical can. The air enters through the inlet at the bottom and the entrained fibers are collected on a stainless steel mesh cylinder inside of this outer case. The soot goes on through the mesh cylinder and is exhausted out the back such

that during the fire test a partial separation of soot from the fibers occurs making the fiber sample easier to count after the test is over. The inlet and exhaust openings are sized for the aerodynamic pressures such that isokinetic flow exists for the velocity range of the hot plume. The vertical array consists of 221 stainless steel mesh cans (figure 16) 9.5 cm in diameter that are mounted on a set of vertical cables that are strung from a catenary between the downwind towers and are used to sample in the plume. For stickiness, the mesh is coated with a high temperature vacuum grease.

Figure 17 is a schematic of the balloon-supported Jacob's ladder, which consists of a net that is 305 m wide and 305 m high. The entire system is constructed with Kevlar cables to minimize weight. The net is suspended from a catenary that in turn is suspended from two blimp-type balloons. These were operated by the Air Force Geophysics Lab who had a balloon crew at Dugway for the duration of this test program. This whole system is stabilized by a series of tether lines out to the sides, in front and rear. The design is based on concepts which have evolved from earlier tethered balloon operations (Reference 5). Distances are such that from one extreme side tether anchor to the corresponding side tether line anchor on the other side is over two km. It's roughly one km from the net to these forward stabilization tie down points. The Washington Monument is drawn in scale on figure 17 just to give a relative sense of the size of this sampling net. Also shown schematically is the kind of intercept area that a typical fire plume would have with that net. The net is anchored 150 m downwind from the fire pool. Depending on the way the wind blows, within the directional constraints, the plume might be over to one side or the other side or right down the middle. Also, depending on velocity, the plume might intercept up near the top, in the middle, or down near the ground.

Figure 18 is a photograph of the net up and flying with one of the balloons and a part of the supporting catenary. The photograph covers about one-quarter of the net, from one side to about the center line and down to about mid-height. What appear to be little white squares at the net intersections of the horizontal and vertical lines, are the mesh viewgraph samplers that are literally a piece of bridal veil mounted in a viewgraph frame that is tied to the net at each of these locations. The net line spacing creates about 15 m squares with a sampler in each corner. This photograph gives an indication of the immensity of the instrumentation problem. For servicing the instrumentation between tests, the balloons were pulled down by winching in the aft tethers and releasing the forward tethers allowing the net to be laid down on a table on the ground that was constructed at about head-height so that people could work in under the net adding, removing or servicing samplers after a test. For each test, the balloons were inflated and the whole net was raised to an operating position as shown, held into the wind by the forward tethers.

The kinds of instrumentation that were used on the net are shown in figure 19. Viewgraphs were located at every one of the 420 intersections on the net. Other types of instrumentation that were on the net were generally in the areas where the heavy black dots are shown. All of this instrumentation, of course, had to be sized to be minimum weight so that it would not pull the net down,

distort it, or pull the balloons and net down. Figure 20 is a photograph of a typical installation where four pieces of instrumentation are located at one particular intersection of a horizontal net line and a vertical net line. This assembly is shown while it's down on the table. From left-to-right are the mesh-covered can which was added to a number of intersections to calibrate the viewgraphs, the mesh-covered viewgraph, and the high voltage Schrader grid. A cardboard version of the Peterson sampler with tail fins attached to keep it pointed into the wind is hanging below the other instruments, but is suspended off to the side slightly when the net is up and flying.

Beyond the balloon supported net, down range on the ground are sampling lines that were put out on the Dugway range at the locations shown in figures 21 and 22. Figure 21 is the short range sampling location out to about 2,000 meters of downwind range. Sampling line identifications are given by the double letter designations. The fire pool and towers are shown approximately to the correct scale. The balloon-supported Jacob's ladder was anchored across the centerline at a location between lines AA and BB. The dashed lines indicate the plus or minus 35° allowable variation in design wind direction which bound the extent of cross-range sampling. The locations of the long-range ground sampling are shown in figure 22. At 19,110 m the sampling line was near the reservation boundary and the sampling line was long enough that it had to be bent to run along the boundary rather than going outside of Dugway's boundary. Figure 23 is a photograph of some of this downwind, long-range sampling area. It's bleak, flat terrain in general. This was taken from a location about 8 km from the fire pool, up on the side of a mountain which parallels the west side of the sampling range. The mountains in the background are off at a distance from here of about 40 km.

Figure 24 shows the specimen support table over the 10.7 m diameter pool. There was 5 - 8 cm depth of water in the bottom of the pool and 12.7 cm depth of fuel was pumped in and floated on top of that. The array of specimens laid out on the table were numbered for identification. Most of them were placed on the downwind side of the table, however, a few were on the upwind side for reference purposes. Typically, 13 to 25 specimens of different aircraft components were placed on the table to be burned in the fire. Also, several of the Peterson samplers can be seen down on the ground attached to the cable array that had not been raised until after work was completed on specimen installation and thermocouple instrumentation on the table.

Figure 25 is a photograph of the start of the second dissemination fire. At ignition, six pyrotechnic flares are set off firing into the fuel in the pool, under the specimens on the table. The over-head Petersons have been raised to an elevation about 30 m above the ground. Figure 26 is the fire after about ten seconds of burning. The large black cloud starting to grow is an indication of a well-established fire with the plume rising, but also being bent over by the prevailing wind. The view was taken from a quartering, upwind position. Figures 27 - 29 are sequence photographs taken after one minute of burning, from a camera position that is perpendicular to the wind direction. Figure 27 is the fire and initial part of the plume with a well-established fire ball extending for several pool diameters. The effect of the wind in blowing the fire to one side of the pool is evident from the amount of the table that is

showing. Strips of material that were delaminating off the specimens as well as clumps and single fibers were being thrown out of the plume as it moves downwind. Swinging the camera around to the right, figure 28 is a photograph of the next part of the plume as it passes between the two downwind towers. Some of the vertical array can be seen in front of the plume, but imaged against the dark background. Some of the Peterson samplers on the near side of the plume also are imaged against it. The plume passes generally through the towers, actually splitting itself on this one tower at this particular time. Figure 29 was taken swinging the camera still farther to the right with the end of the plume penetrating through the viewgraph samplers that were mounted on the Jacob's ladder net supported from the balloons. The net cables are not visible in this picture and the balloons are well above the top of the picture. But this gives a view of the adequacy of the instrumentation intercepting the plume.

The next sequence of photographs (figures 30 - 32) was taken from a location about 5 km to the side and 2 km downwind from the fire site after about 10 minutes of burning. Figure 30 shows the plume building up and passing through, but well beneath the two balloons supporting the Jacob's ladder. Swinging the camera around to track the full length of the plume down range in figures 31 and 32, the plume remains essentially at constant height against an inversion, but is approximately 6 km long. The end of the plume terminates just beyond figure 32. The mountain in the background is 12 km away.

Figure 33 shows typical residual material that was left on the rack after the 20-minute fire test. This is residual material from the third dissemination fire. It was two horizontal components and the vertical component of a tail from an F-16 fighter aircraft, which were burned in a fire identical to the second fire. In this fire, however, the steel table that was supporting the specimen collapsed after 5 minutes of burning. Nevertheless, the components stayed in the fire and show evidence of being well torn up, delaminated, and burned.

The other type of fire, a source fire, with essentially a zero wind condition is shown in the next sequence of photographs. Figure 34 was taken at ignition. The specimen table has been re-built from the last fire and is over the other fire pool. As the fire starts, figure 35 shows it at 6 seconds; figure 36 shows it at 30 seconds; and figure 37 shows it at one minute. Development of the plume going essentially straight up and being sampled entirely in the overhead Peterson canopy can be clearly seen as time advances. Another series of photographs that was taken from a helicopter of this same fire are shown in figures 38 - 43. The helicopter was flying in the vicinity of the fire throughout the time, but generally circling around the plume so in some of these pictures the cloud pattern or the shadow on the ground will change positions depending on the location of the helicopter. And as time continues on, the plume rises up to the inversion layer, flattens out, and then drifts slowly in the direction of the prevailing low velocity wind. Ground observers stated that the cloud persisted in the general area for times up to four hours after the fire.

Figure 44 is a summary of the meteorological conditions in each of these five tests. The three with dissemination had wind speeds on the order of five

meters per second. The significant thing here is that the wind direction was essentially on the two limits on the first two tests, but on the third test the wind was close to the design wind direction of 320 degrees. Weather stability condition was neutral on these dissemination tests. It was stable on the last two source tests where there was essentially no wind velocity and variable direction.

One obvious outcome of the three dissemination tests was the strips of material that delaminated and were carried downwind for a short distance before they fell out of the plume and deposited on the ground (figure 45). These were picked up on sweeps out over the ground area that defined the magnitude of the density of the strips and the quantity of material that was picked up. The first test was off to the west, the second test was off to the east, and the third test right down the center line. The third test deposited material a bit farther downwind than the first two. The location of the Jacob's ladder net at about 120 m downwind from the fire pool made it necessary for strips to pass through the sampling net to get to the indicated areas on the ground. Figure 46 is a photograph of one of the viewgraphs on the sampling net that indicates that it intercepted two of these strips. There are also a large number of single fibers on the viewgraph but they don't show up at this magnification.

The high voltage Schrader grids flown on the net gave an indication of the rate at which fibers were being deposited on the samplers on the Jacob's ladder. Figure 47 shows the fiber deposition for one particular net intersection about in the middle of the plume on the third dissemination fire test. Although the rate is not linear, it does indicate a continuous flow of fibers during the burn after the initial 2 - 3 minutes from ignition. The maximum deposition is on the order of about 2×10^4 fibers per square meter.

Figure 48 is a tabulation of an estimate by the Dugway data analysis group on the single fibers that were released in each of the tests. Note that the total number of fibers released in each of these tests was on the order of 10^8 . There were variations from individual test to individual test, but not significantly different. The amount of carbon fiber mass in the fire was essentially the same except for test D-3 which was the F-16 composite tail, and weighed about 60 percent more than the carbon fiber components in the rest of the tests. That fewer total single fibers came out of this test may have been due to the larger, heavier four pieces of composite or to the change in location within the fire when the table collapsed. But even with these differences the percent of single fibers released is all within a factor of three. Note that the average length of released fiber was as high as five millimeters. The last test was run only last week and not all of the results are available for it. The maximum release for these tests was 0.13 percent.

Figure 49 provides a "quick-look" at what was intercepted on the Jacob's ladder sampling net from initial readings of the viewgraphs. The outline in the upper left of the figure is the intercept of the cloud or the soot outline on the net as it was picked off from the various viewgraphs. The symbols indicate areas in which clumps were found, and they're pretty well distributed over the whole cross section of the plume. Viewgraphs were read along two

cuts through the plume to get a quick look at the data. A vertical cut roughly through the middle of the plume showed the distribution of fibers indicated in the upper right of the figure. There seem to be several peaks vertically on fiber deposition, but peak values are on the order of 10^4 fibers per square meter. A horizontal cut also taken near the center of the plume is shown in the lower left. Again the peak value is about 2×10^4 which is not too much different from what was shown on the high voltage grid, (figure 47).

Finally, figure 50 lists the peak exposure levels measured from the downwind deposition of fibers on ground-based samplers for distances to 19,000 meters. These are the maximum exposure levels that were detected on those various cross range sampling lines from each of the first three dissemination trials. Close to the fire, the maximum exposure values are on the order of 10^3 fibers/ m^3 , but at greater downwind distances the exposures are almost at the point of being insignificant, but still are statistically sampleable on this system. These measured peak exposures also agree reasonably with predicted values from reference 6.

Concluding Remarks

Figure 51 summarizes the conclusions drawn from the large-scale fire-released fiber tests. They are considered to be tentative because much of the data are preliminary at this time due to the recent performance of the outdoor tests.

The greatest fiber release observed was the one-half percent in the Dahlgren Shock Tube where the composite was burned with a continuous agitation to total consumption. In the large-scale, outdoor fires at Dugway Proving Ground the greatest fiber release was 0.13 percent. Therefore, the one percent release that has been used in the risk calculations appears to be conservative.

Fiber length averages are based on measured lengths of those fibers that are greater than one millimeter in length. In the shock tube with the forced agitation the average length was two millimeters. Outdoors, the largest average length obtained for any one test was five millimeters. These two values bracket the three millimeter length used in the risk calculations.

Equipment vulnerability to fire-released carbon fibers was nearly identical to vulnerability in chamber tests which justifies the use of the carbon fiber chamber test data in the risk calculations.

REFERENCES

1. Carbon Fiber Risk Analysis. Publication of an industry/government briefing held at Langley Research Center, Hampton, Virginia October 31 - November 1, 1978. NASA CP- 2074.
2. Taback, Israel: Evaluation of Equipment Vulnerability and Potential Shock Hazards. Assessment of Carbon Fiber Electrical Effects, NASA CP-2119, 1980. (Paper 5 of this compilation.)
3. Lieberman, P., Chovit, A. R., Sussholz, B., and Korman, H. F.: Data Reduction and Analysis of Graphite Fiber Release Experiments. NASA CR-159032, 1979.
4. Asad, N. N.: Carbon/Graphite Fiber Risk Analysis and Assessment Study. Volume II A Statistical Assessment of Fire Damage to Airframe Components. Appendix B Accident Review Sheets. NASA CR-159031, 1979
5. Proceedings, AFCRL Tethered Balloon Workshop, 1967. Thomas W. Kelly, Editor. AFCRL-68-0097, Special Reports, No. 72, 1968.
6. Dumbauld, R. K.: Calculated Dosage Isopleths and Dosage Area-Coverage for the Proposed NASA Graphite Particle Trials. U. S. Army Dugway Proving Ground TR-78-307-05, 1978.

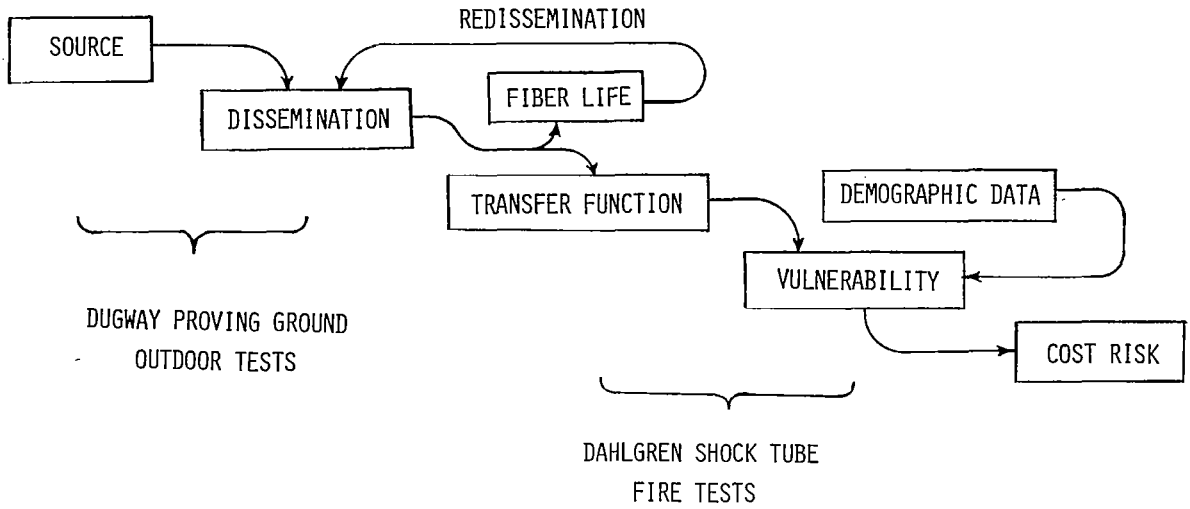

Figure 1.- Risk analysis elements.



Figure 2.- Dahlgren "shock tube" burn test.

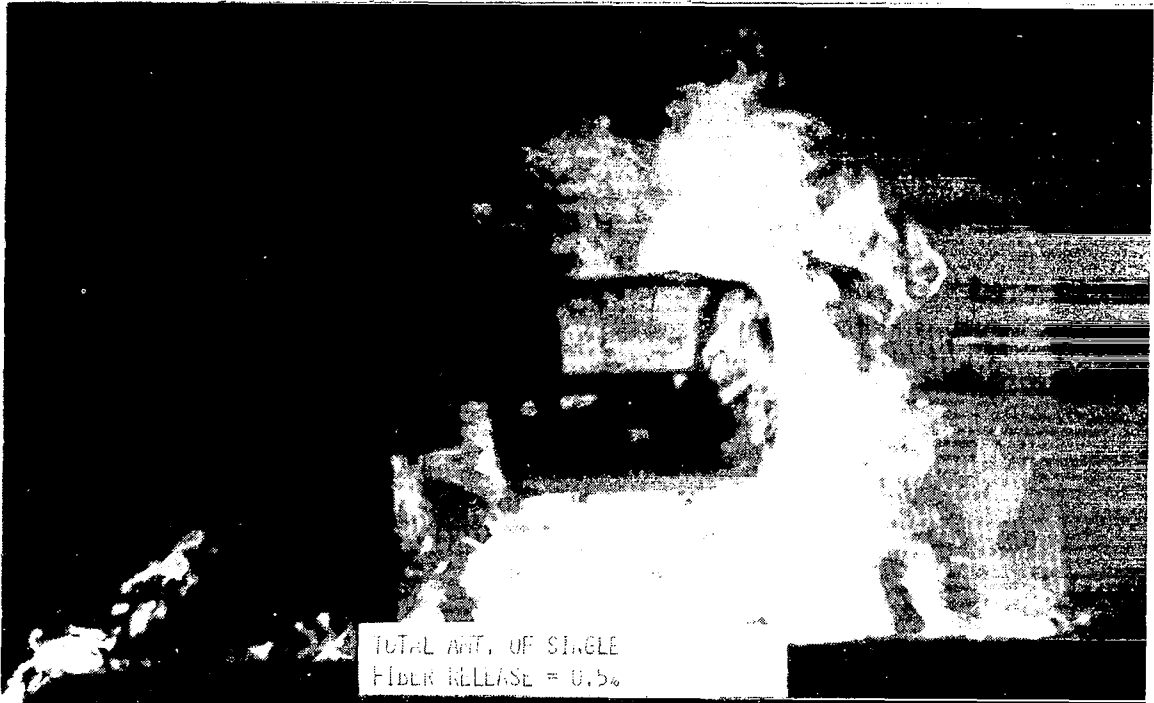

Figure 3.- Rotisserie agitation of carbon composites.

● FIRE	SIZE	1.2 m SQUARE (4 FT.)
	DURATION	206 MIN.
	FUEL	0.371 m ³ (98.1 GAL.) COMMERCIAL JET A
	FLAME TEMPERATURE	950-1000°C (1740-1830°F)
● COMPOSITE	INITIAL MASS	9,988 kg
	BURN TIME	134 MIN.
	RESIDUAL MASS RECOVERED	3,361 kg
● EXPOSURE TABLE	AIR FLOW	18.9 m ³ /s (40,000 CFM)
	AIR VELOCITY	0.67 m/s (1.5 MPH)
	AMBIENT TEMPERATURE	25°C (77°F)
	TEST TEMPERATURE	30° (86°F)

Figure 4.- Dahlgren shock tube fire test parameters, test 53.

STICKY PAPER DEPOSITION	48
STICKY CYLINDER CONTINUOUS SAMPLING	95
STICKY CYLINDER INCREMENTAL TIME SAMPLING	75
PETERSON SAMPLER	6
SCHRADER HIGH VOLTAGE GRID	1
LED	1
NIOSH MILLIPORE FILTER	2
	<hr/>
	228

Figure 5.- Fiber sampling instrumentation for Dahlgren shock tube fire test 53.

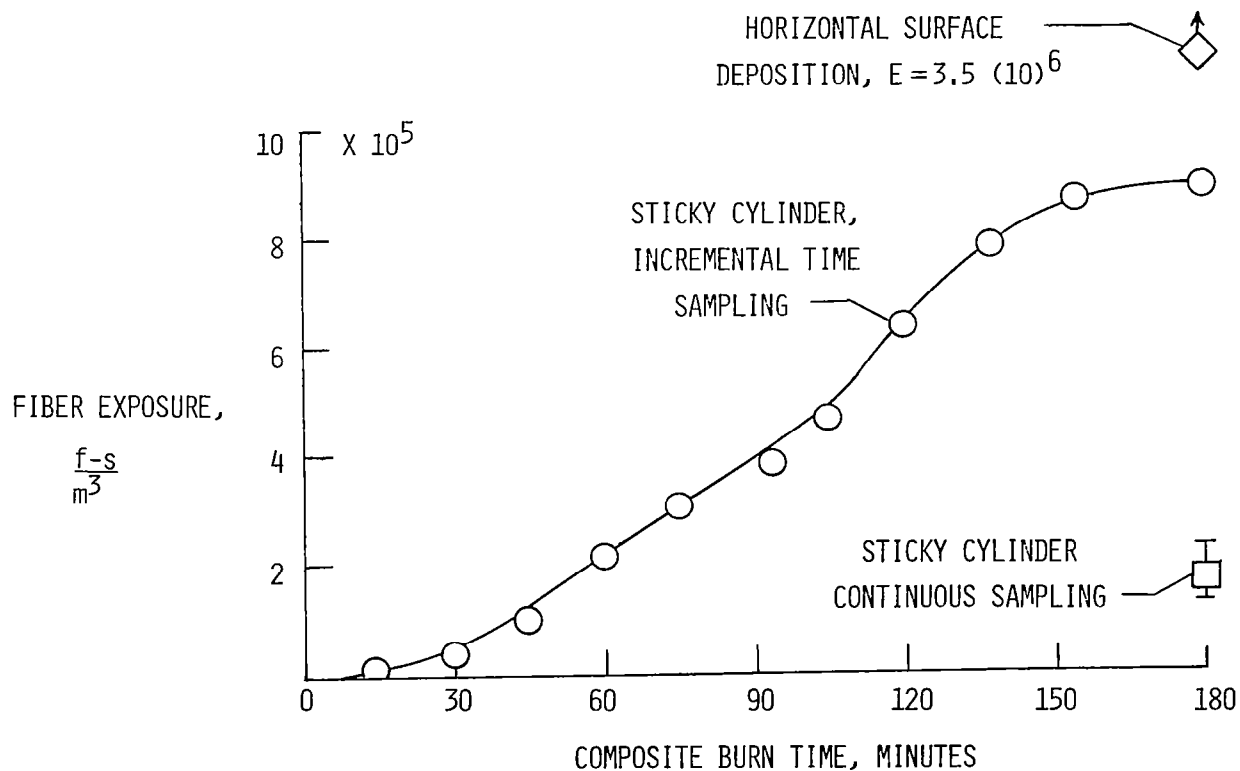

Figure 6.- Carbon fiber exposures measured by sticky paper samplers for Dahlgren shock tube fire test 53.

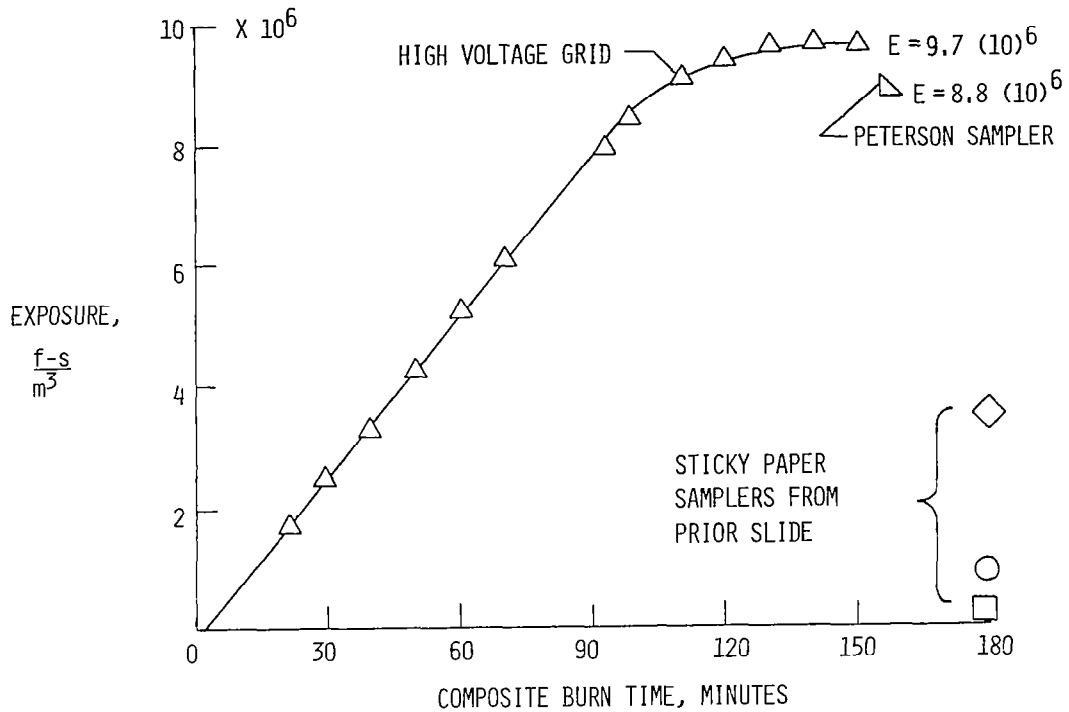

Figure 7.- Carbon fiber exposures determined by all instrumentation for Dahlgren shock tube test 53.

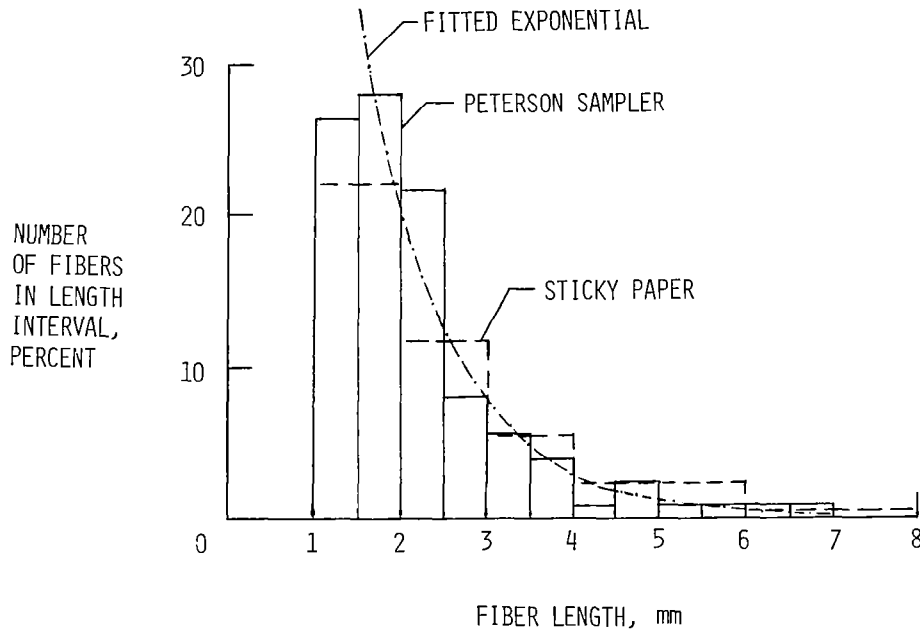

Figure 8.- Fire-released carbon fiber length distribution for Dahlgren shock tube fire test 53.

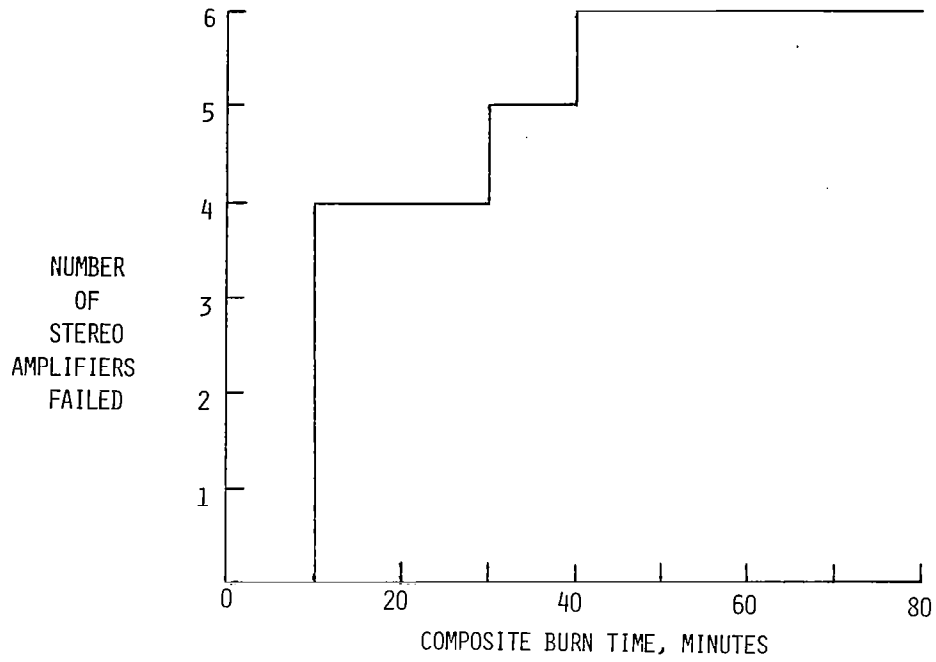

Figure 9.- Electronic equipment failures for Dahlgren shock tube fire test 53.

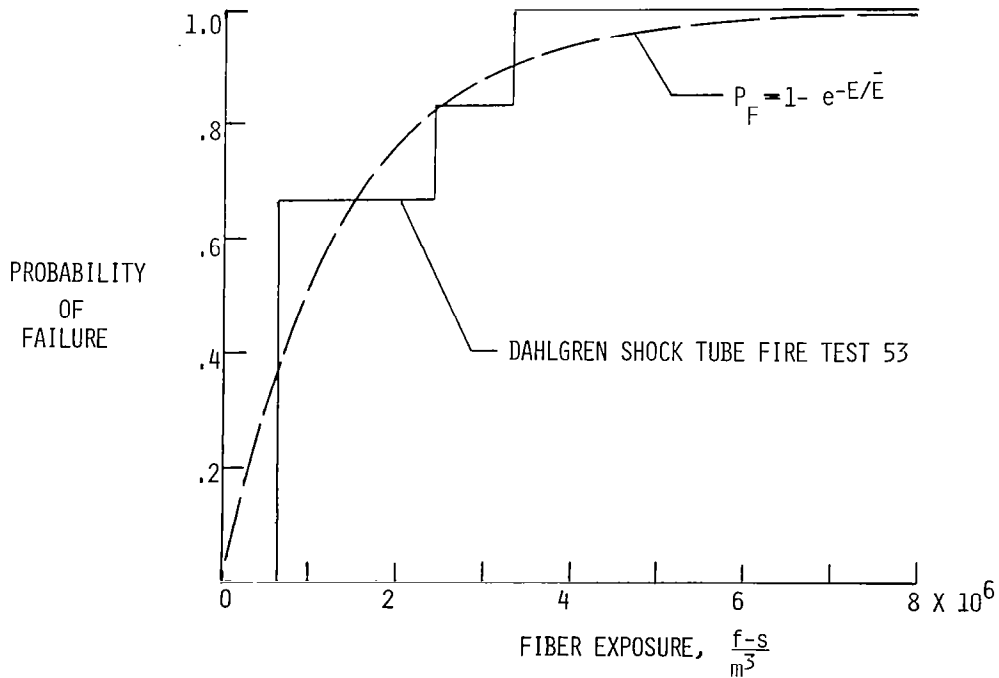

Figure 10.- Probability of electronic equipment failures from exposure to fire-released carbon fibers and to virgin carbon fibers.

FIRE	SIZE	10.7 m DIAMETER (35 FT.)
	DURATION	20 MINUTES
	FUEL	11.36 m ³ (3000 GAL.) JP-4
COMPOSITE	45 kg (100 LB.)	CARBON-EPOXY AIRCRAFT COMPONENTS
WEATHER	SOURCE TESTS	WIND SPEED 0-0.4 m/s
	DISSEMINATION TESTS	WIND SPEED 2.7-5.4 m/s
		WIND DIRECTION 320° ± 35°

Figure 11.- Outdoor fire test parameters at Dugway Proving Ground.

TOWER SUPPORTED:

PETERSON SAMPLER, OVERHEAD	61
VERTICAL ARRAY MESH CAN	221
	<hr/>
	282

BALLOON-SUPPORTED JACOB'S LADDER:

MESH VU-GRAPH	420
MESH CAN	95
CARDBOARD PETERSON	30
NIOSH MILLIPORE FILTER	10
LED	2
SCHRADER HIGH VOLTAGE GRID	8
	<hr/>
	565

GROUND SUPPORTED, 91 m - 19,100 m DOWNWIND

MESH CAN	833
STICKY PAPER	464
TIME CONCENTRATION	10
ROTO-ROD	15
	<hr/>
	1322

Figure 12.- Fiber sampling instrumentation for outdoor fire tests at Dugway Proving Ground.

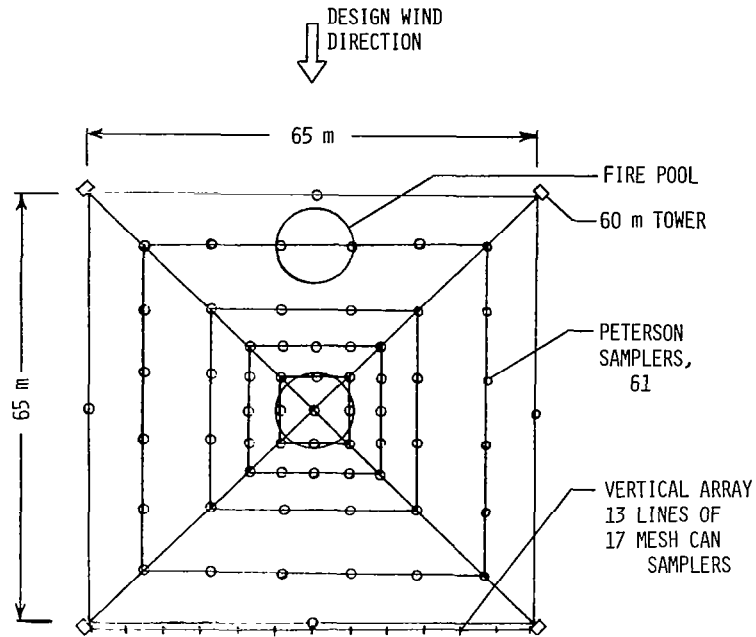

Figure 13.- Test-site layout for outdoor fire test at Dugway Proving Ground.

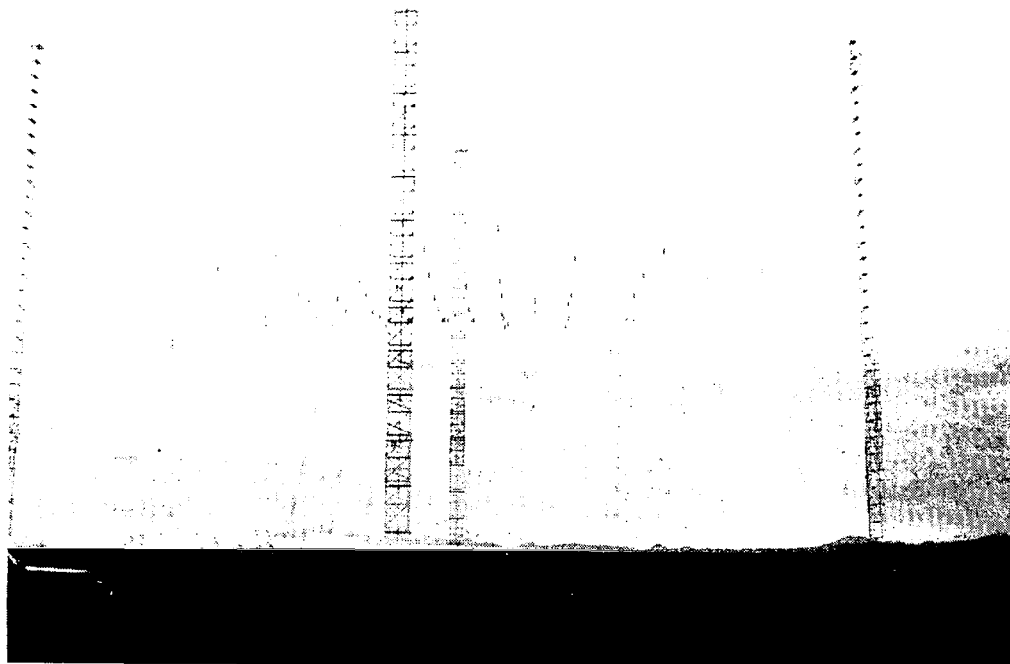

Figure 14.- Overhead Peterson sampler array suspended from towers at Dugway Proving Ground.

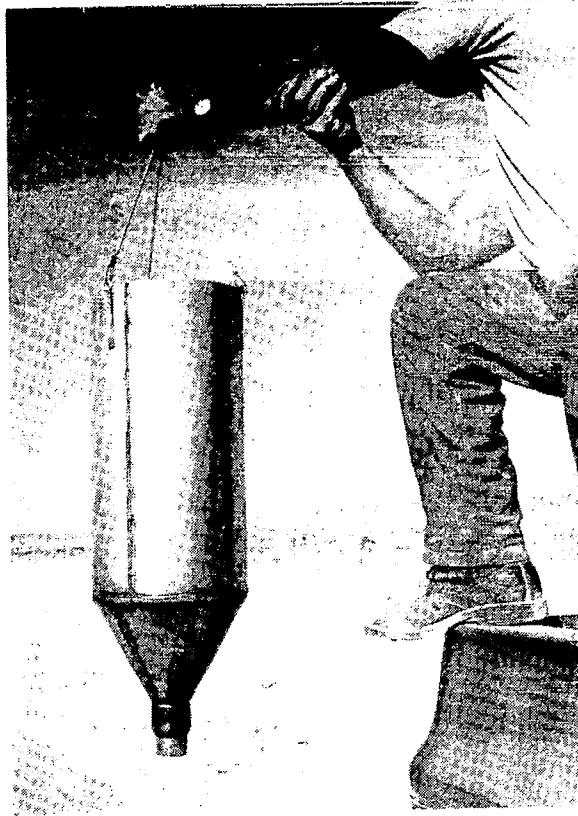

Figure 15.- Peterson sampler.

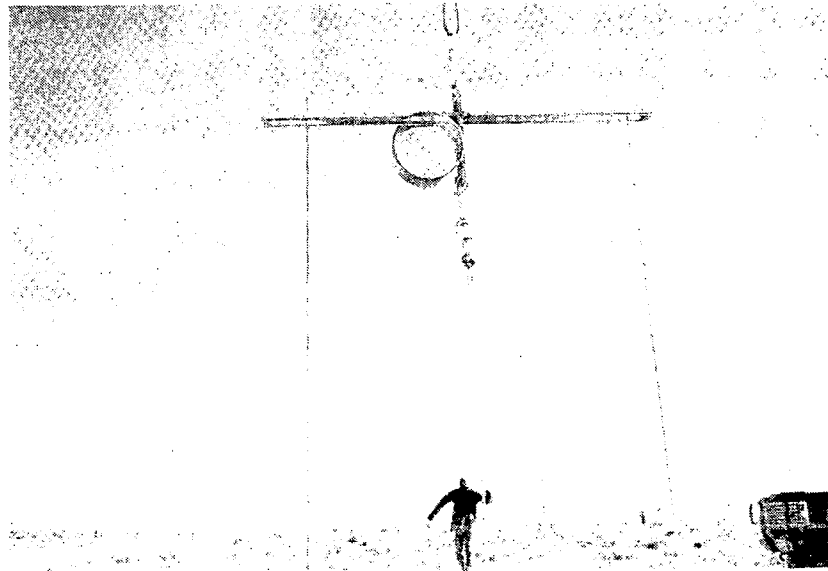

Figure 16.- Stainless steel mesh can - sampler
on vertical array.

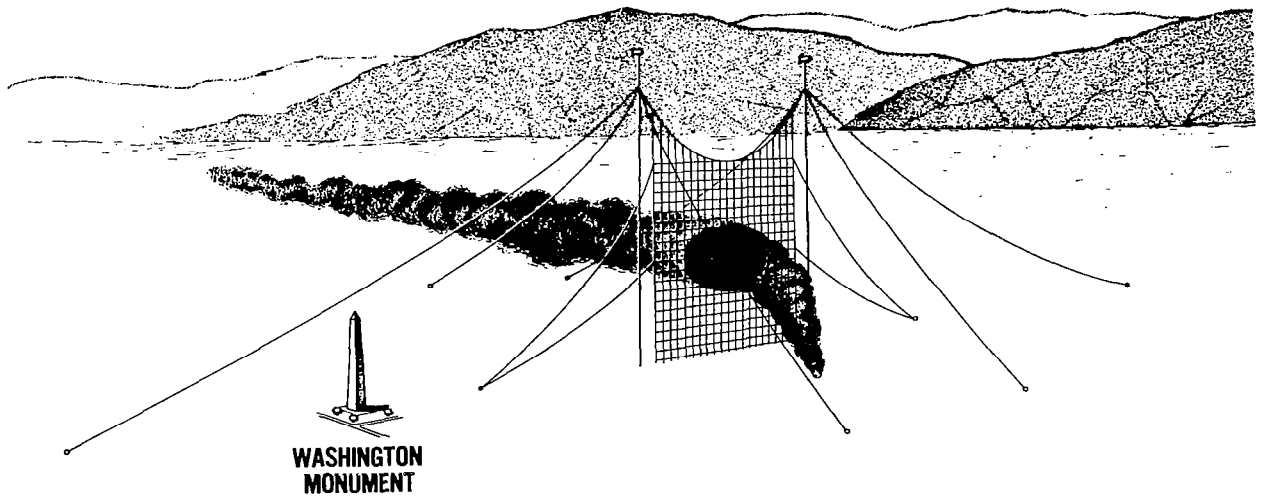

Figure 17.- Balloon-supported Jacob's ladder fire plume sampling net.

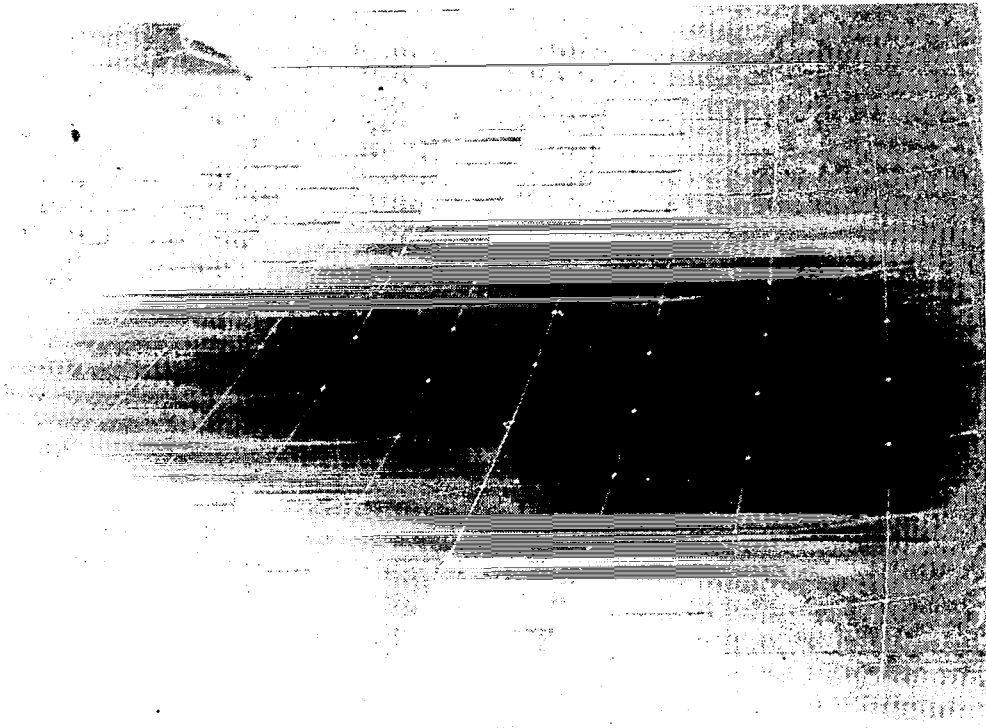

Figure 18.- Balloon-supported Jacob's ladder sampling net.

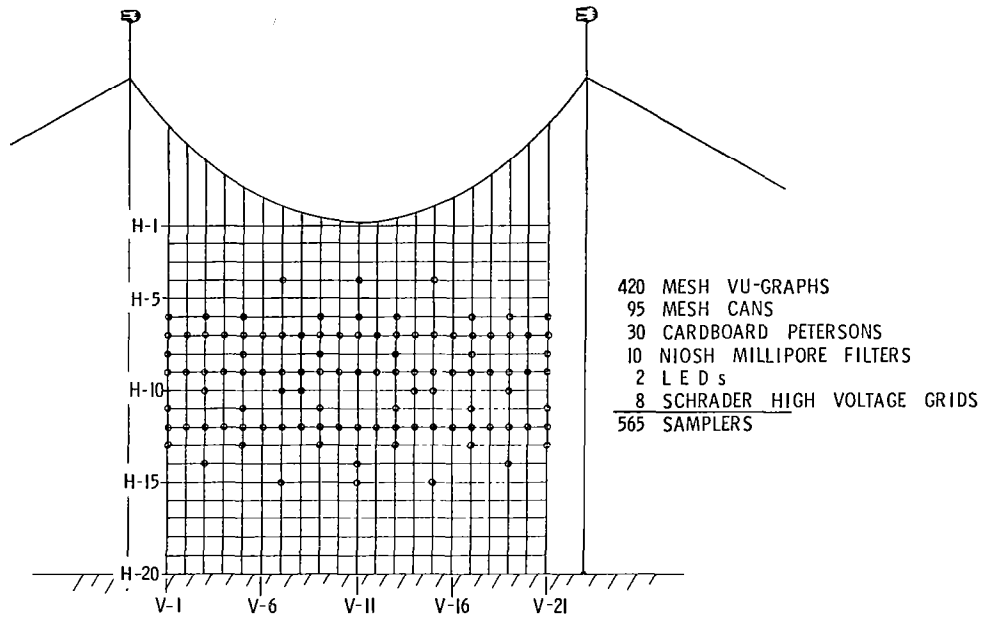

Figure 19.- Instrumentation on Jacob's ladder fire plume sampling net.

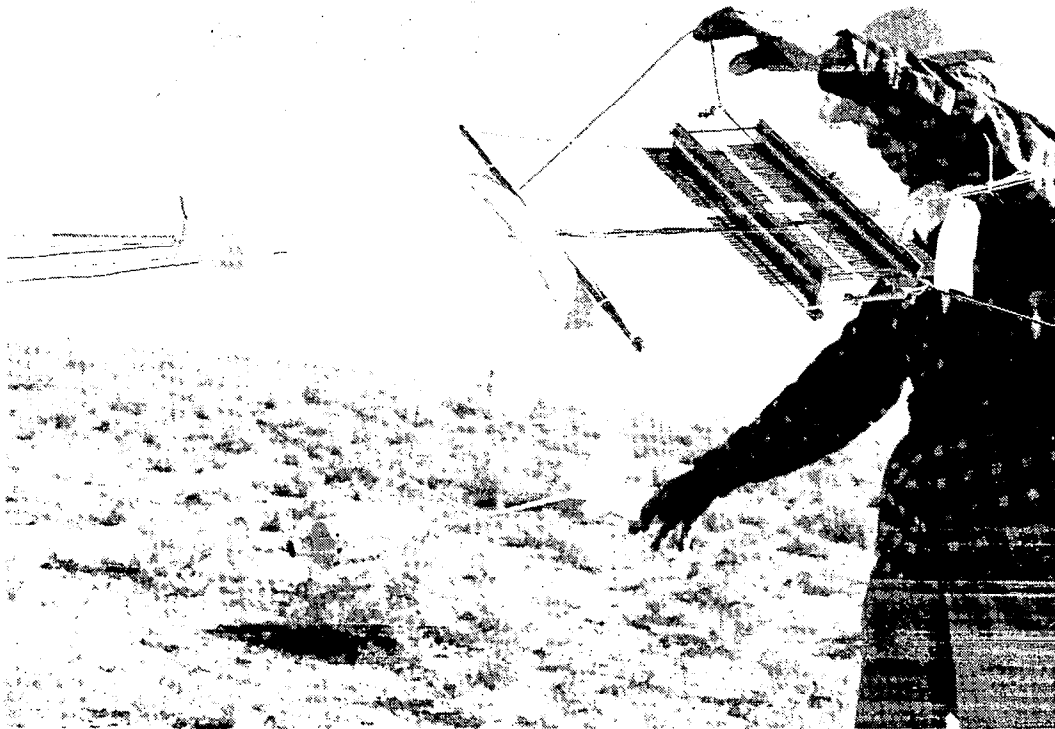

Figure 20.- Instrumentation on Jacob's ladder.

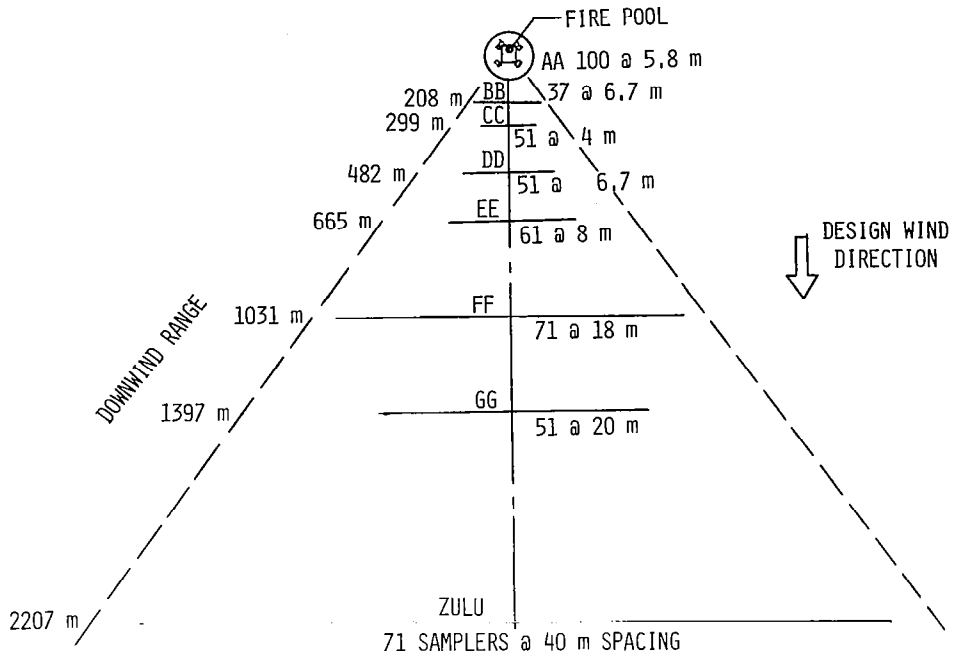

Figure 21.- Short range ground-supported fiber sampling lines at Dugway Proving Ground.

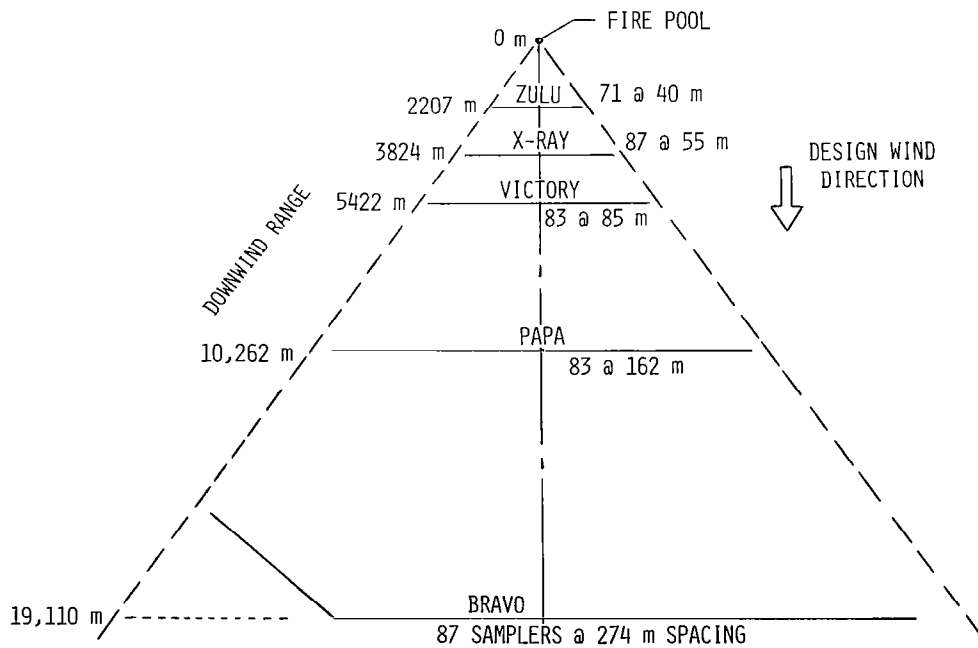

Figure 22.- Long range ground-supported fiber sampling lines at Dugway Proving Ground.



Figure 23.- Downwind, long-range sampling terrain.

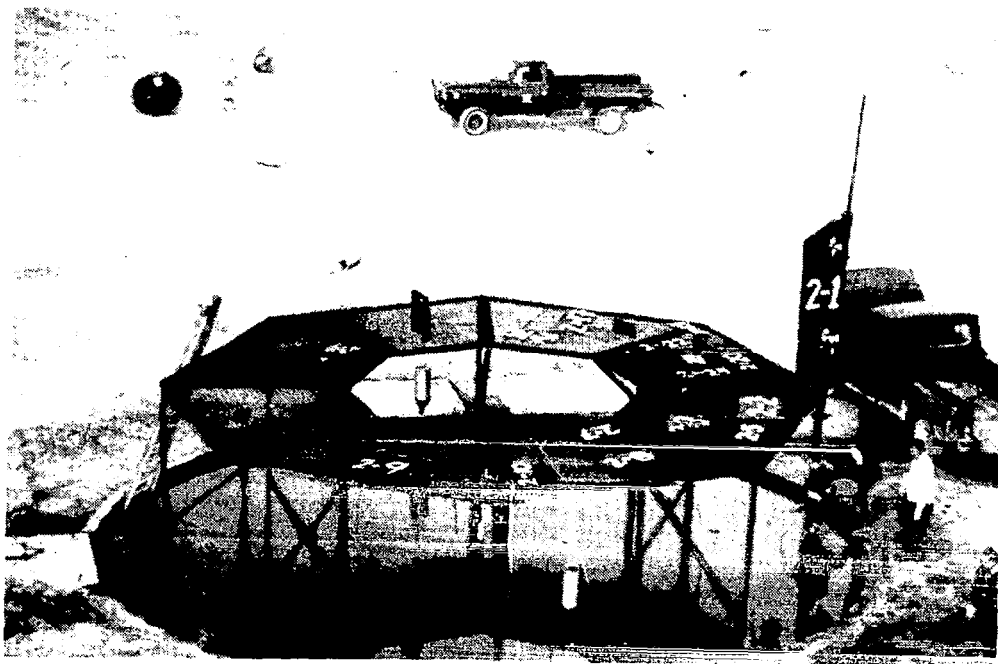

Figure 24.- Specimen support table over fire pool.

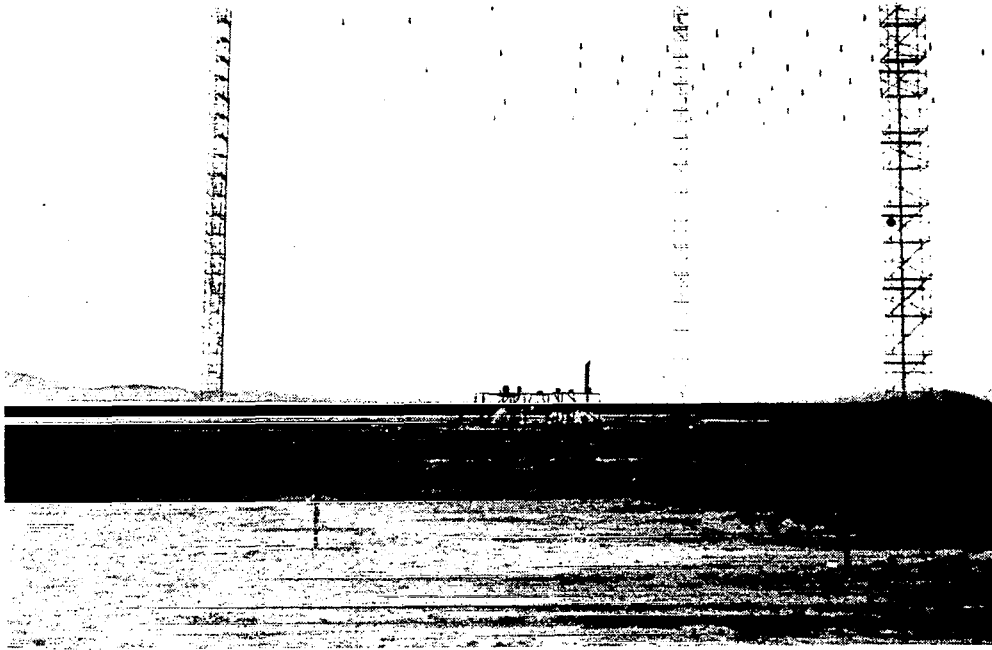

Figure 25.- Ignition of jet fuel in fire pool at start of second dissemination test.

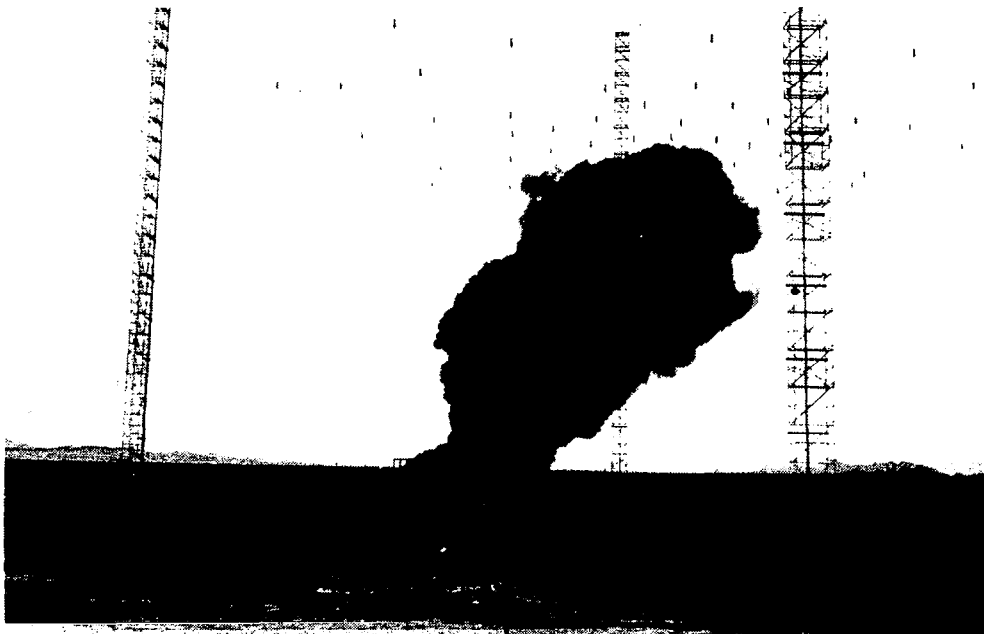

Figure 26.- Ten seconds after ignition of dissemination fire test, D-2.

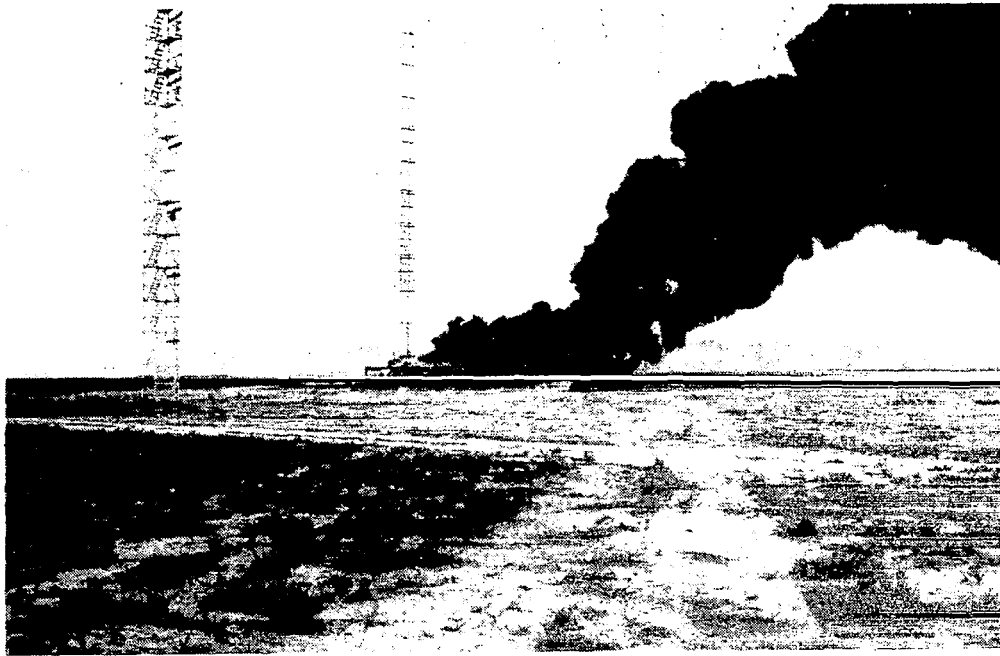

Figure 27.- Initial part of fire plume one minute after ignition, test D-2.

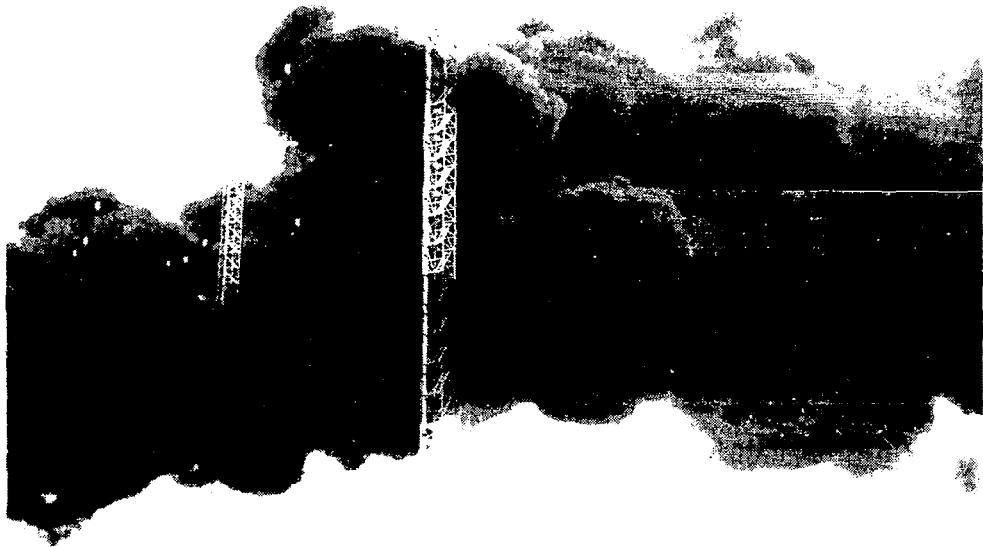

Figure 28.- Part of fire plume passing between two downwind towers, one minute after ignition, test D-2.

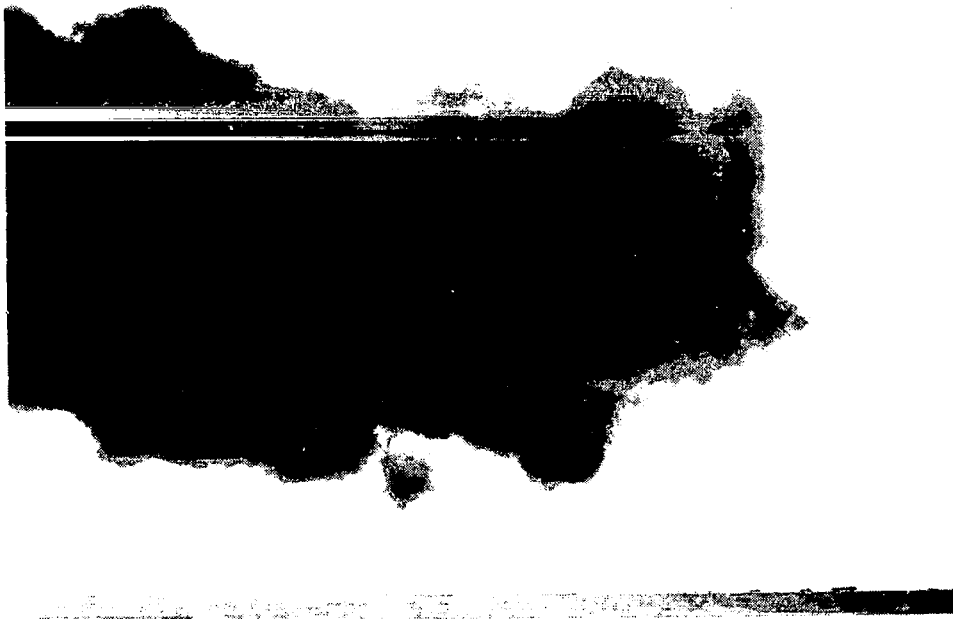

Figure 29.- End of fire plume, one minute after ignition, test D-2.



Figure 30.- Initial part of 6 km long plume, 10 minutes after ignition, test D-2.



Figure 31.- Middle part of 6 km long plume, 10 minutes after ignition, test D-2.

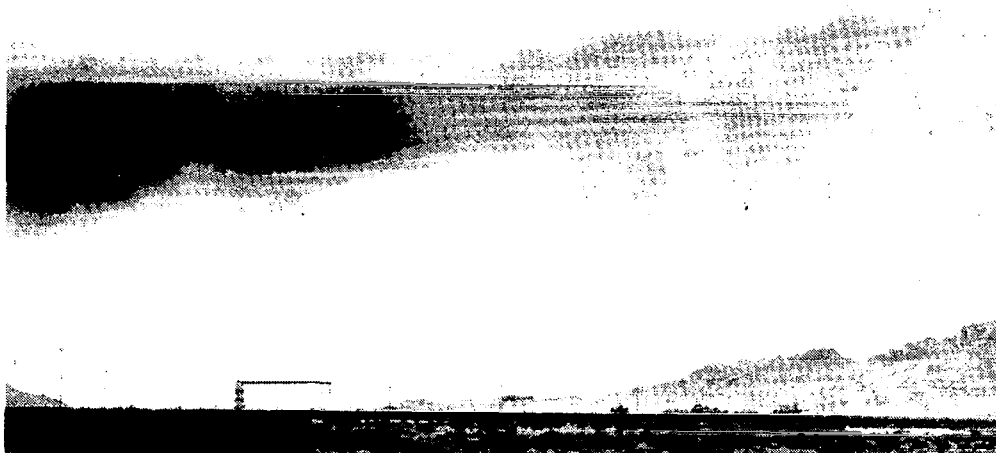

Figure 32.- Near end of 6 km long plume, 10 minutes after ignition, test D-2.

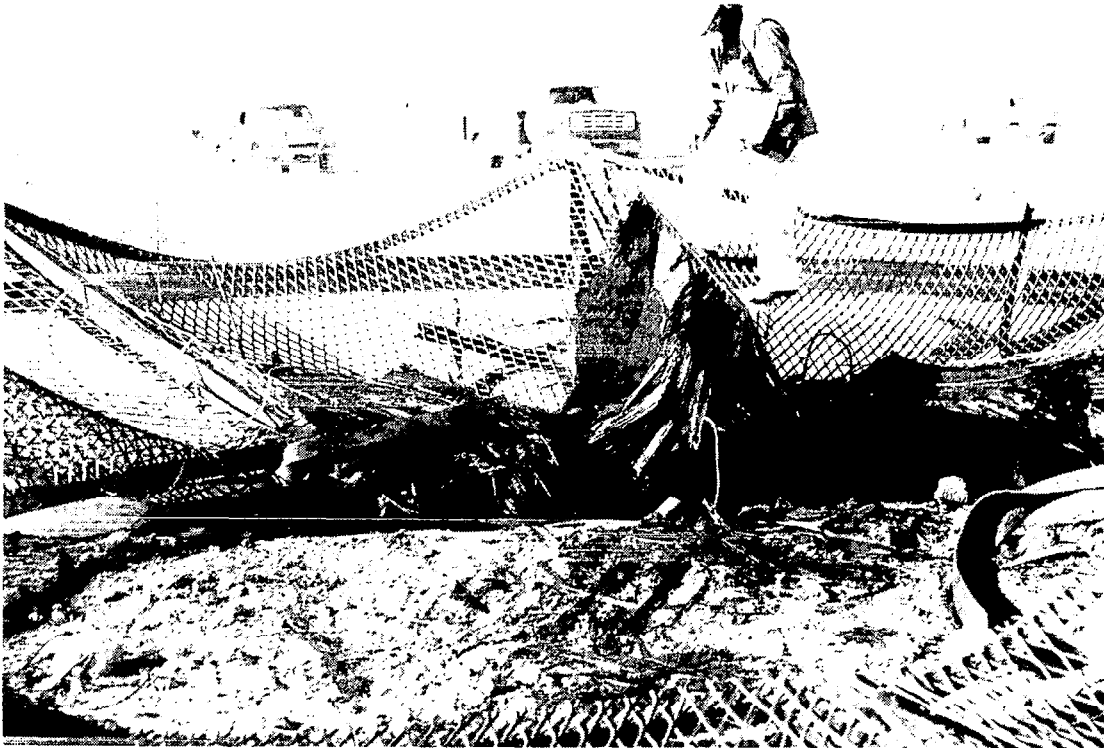

Figure 33.- Residual material after 20-minute burn of F-16 carbon fiber-epoxy tail at Dugway Proving Ground, test D-3.



Figure 34.- Composite specimens on rack over 11-meter pool fire for test S-1 - ignition.

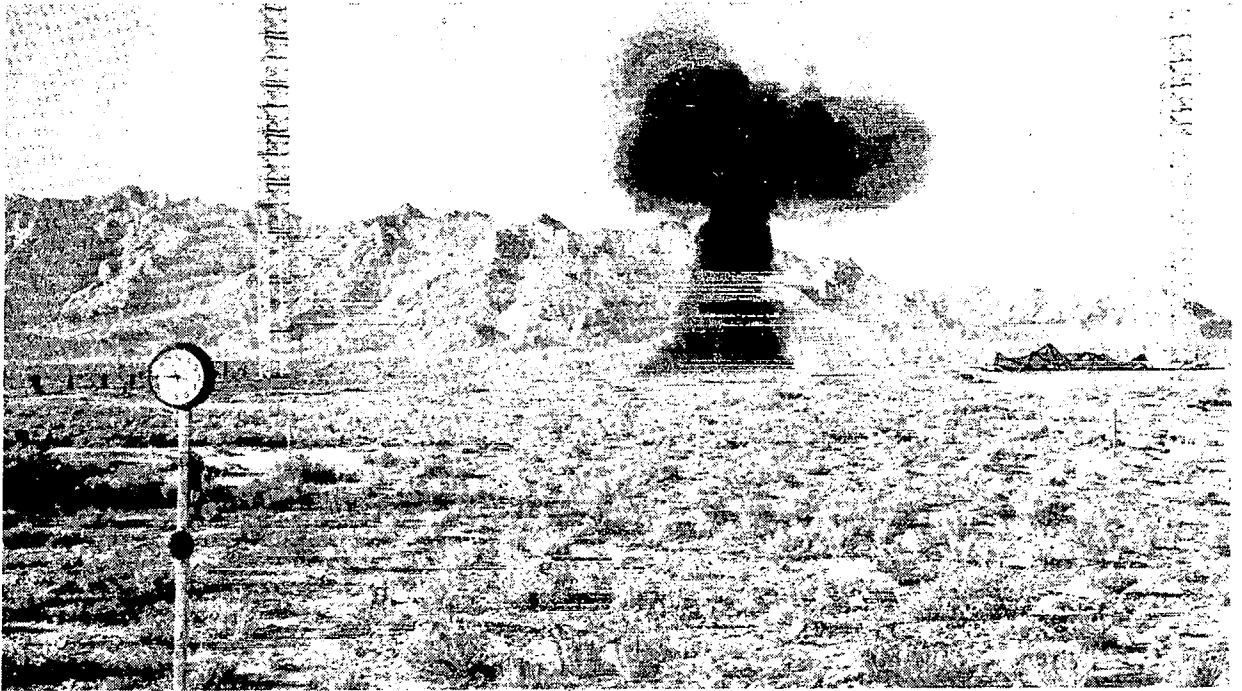

Figure 35.- 11-meter pool fire test S-1 - 6 seconds.



Figure 36.- 11-meter pool fire test S-1 - 30 seconds.

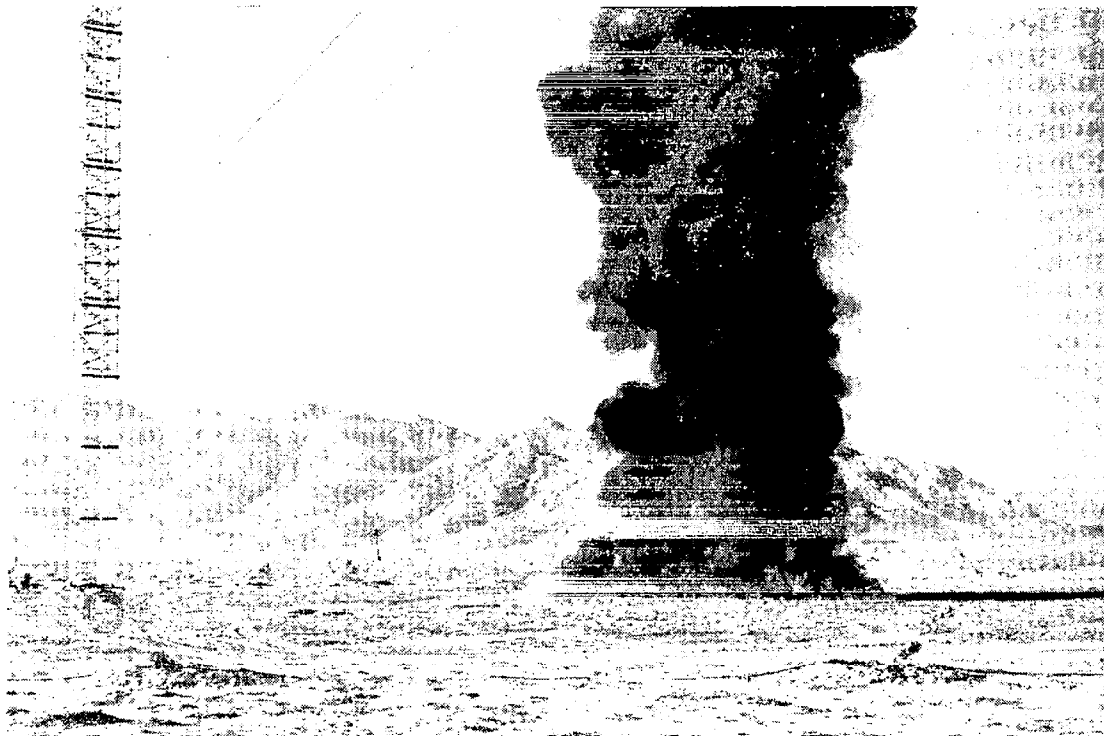

Figure 37.- 11-meter pool fire test S-1 - 1 minute.

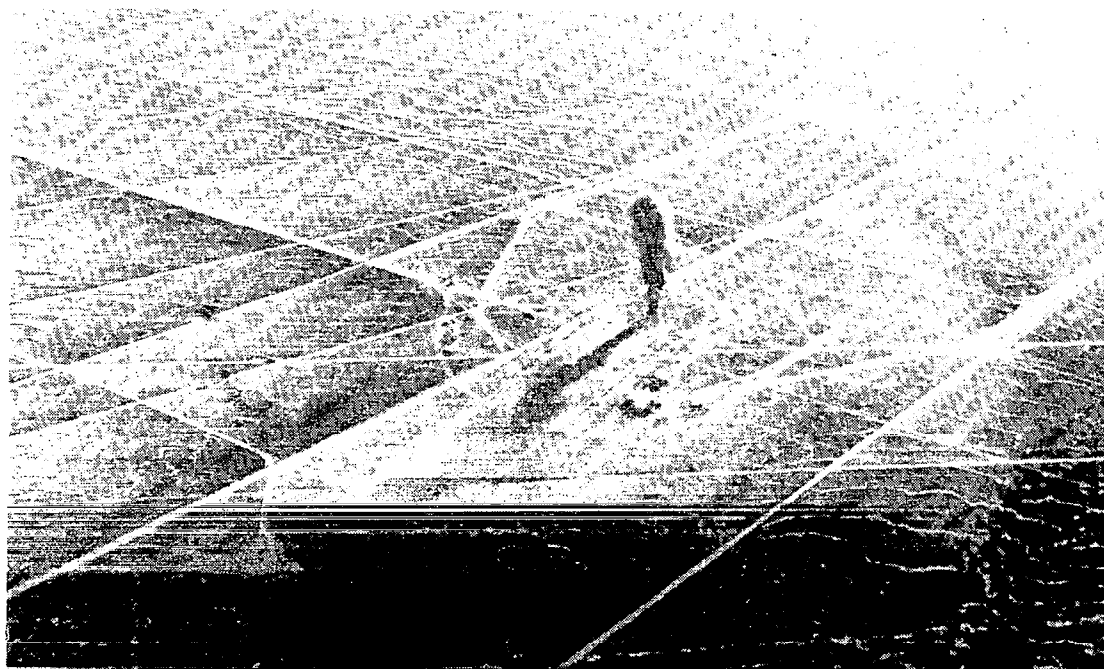

Figure 38.- 11-meter pool fire test S-1 - 20 seconds, helicopter.

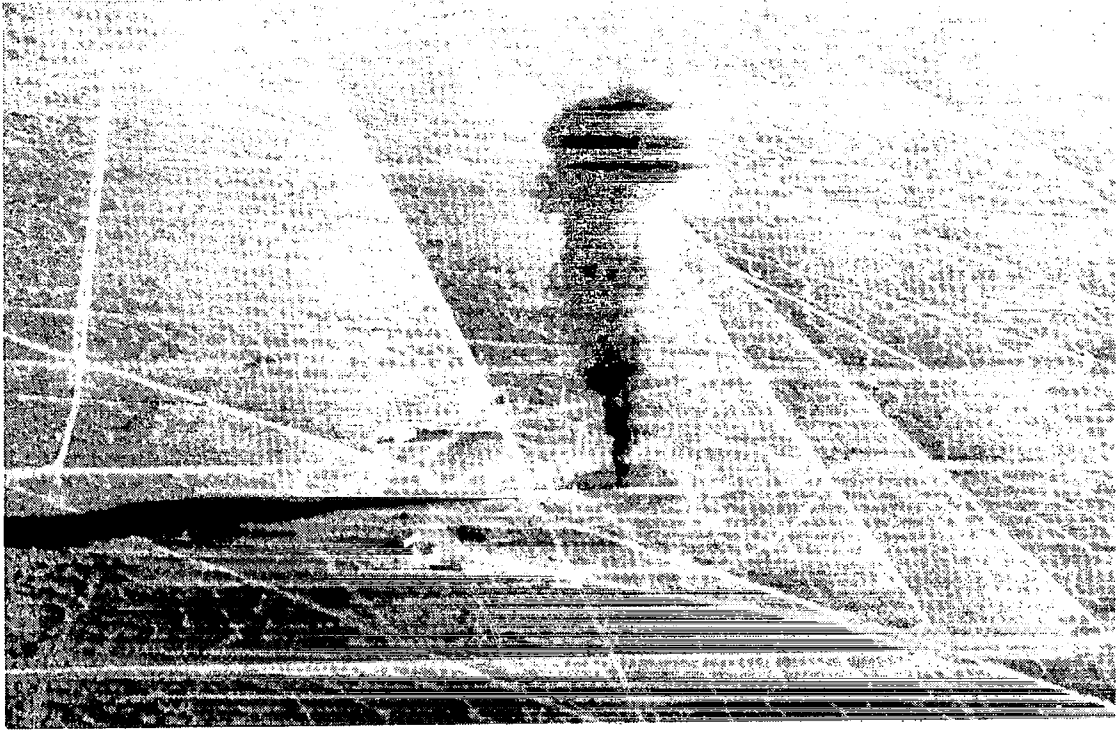

Figure 39.- 11-meter pool fire test S-1 - 50 seconds, helicopter.

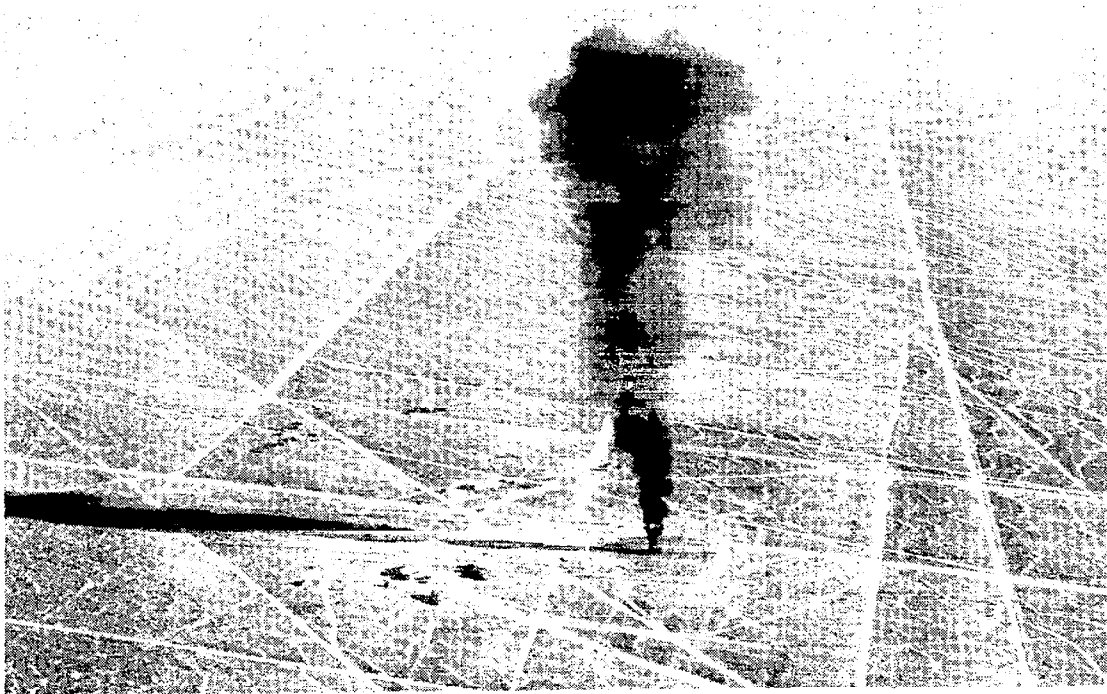

Figure 40.- 11-meter pool fire test S-1 - 80 seconds, helicopter.



Figure 41.- 11-meter pool fire test S-1 - 3 minutes
30 seconds, helicopter.



Figure 42.- 11-meter pool fire test S-1 - 4 minutes
45 seconds, helicopter.

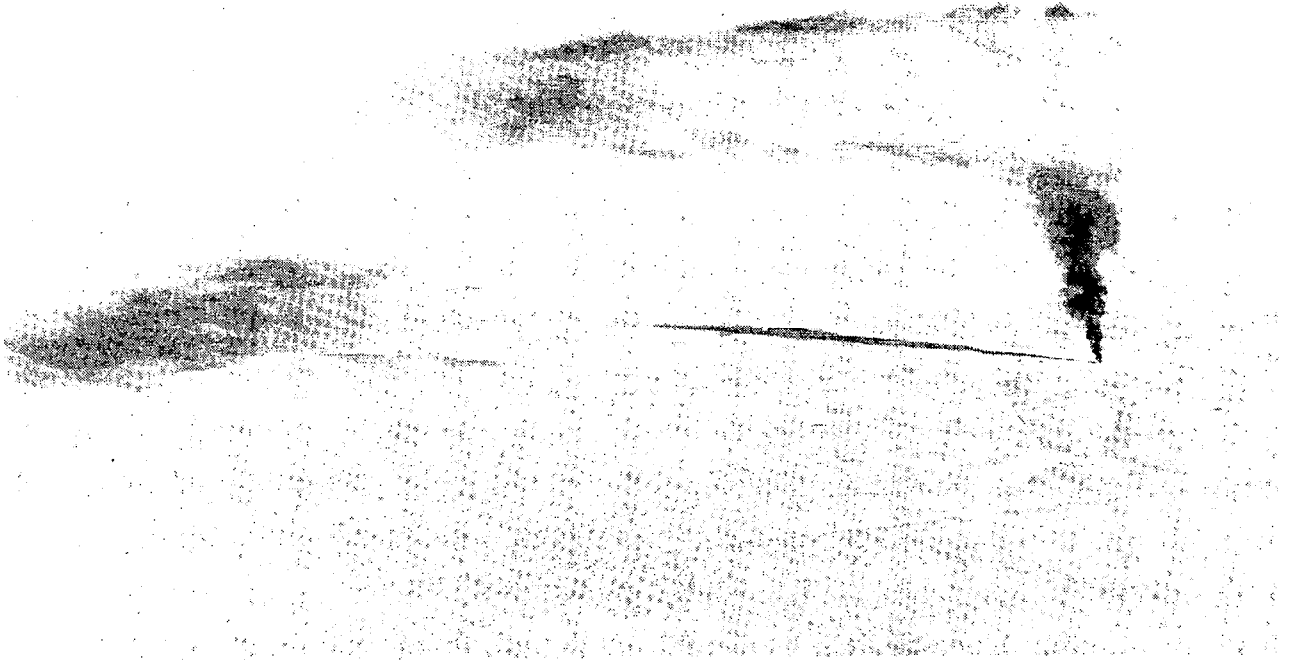

Figure 43.- 11-meter pool fire test S-1 - 14 minutes, helicopter.

TRIAL	WINDSPEED (METERS/SEC)	WIND DIRECTION (DEGREES)	STABILITY CATEGORY
D-1	6.4	360	NEUTRAL
D-2	5.8	289	NEUTRAL
D-3	5.3	326	NEUTRAL
S-1	< 1.0	VARIABLE	STABLE
S-2	< 2.0	VARIABLE	STABLE

Figure 44.- Meteorological summary - measurements made during burn time at 8 meters above ground upwind of fire location.

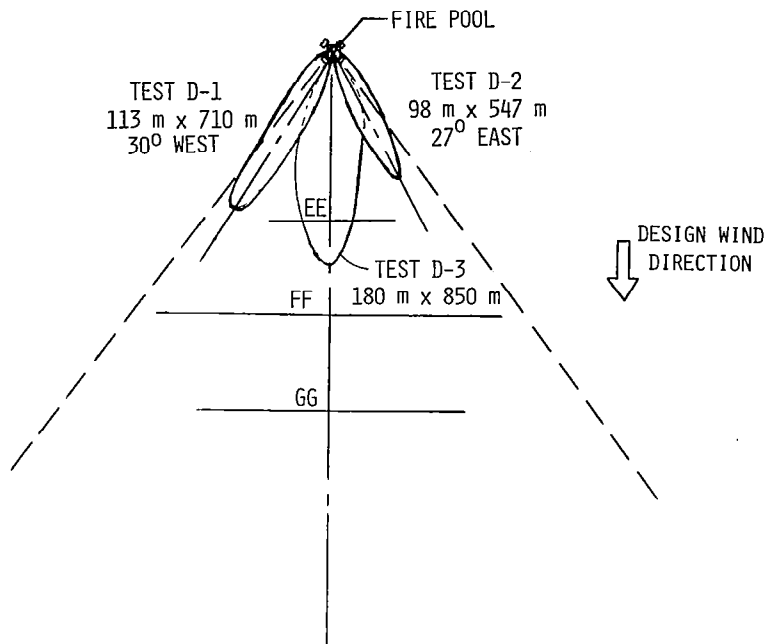

Figure 45.- Ground footprints of composite strip fallout downwind.

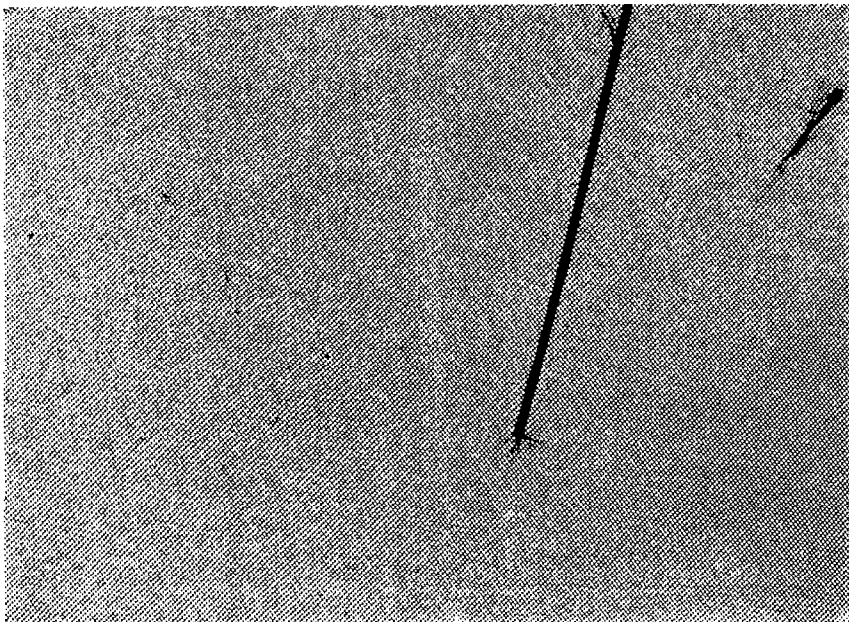

Figure 46.- Two fiber strips deposited on Jacob's ladder mesh viewgraph at Dugway outdoor fire test D-3.

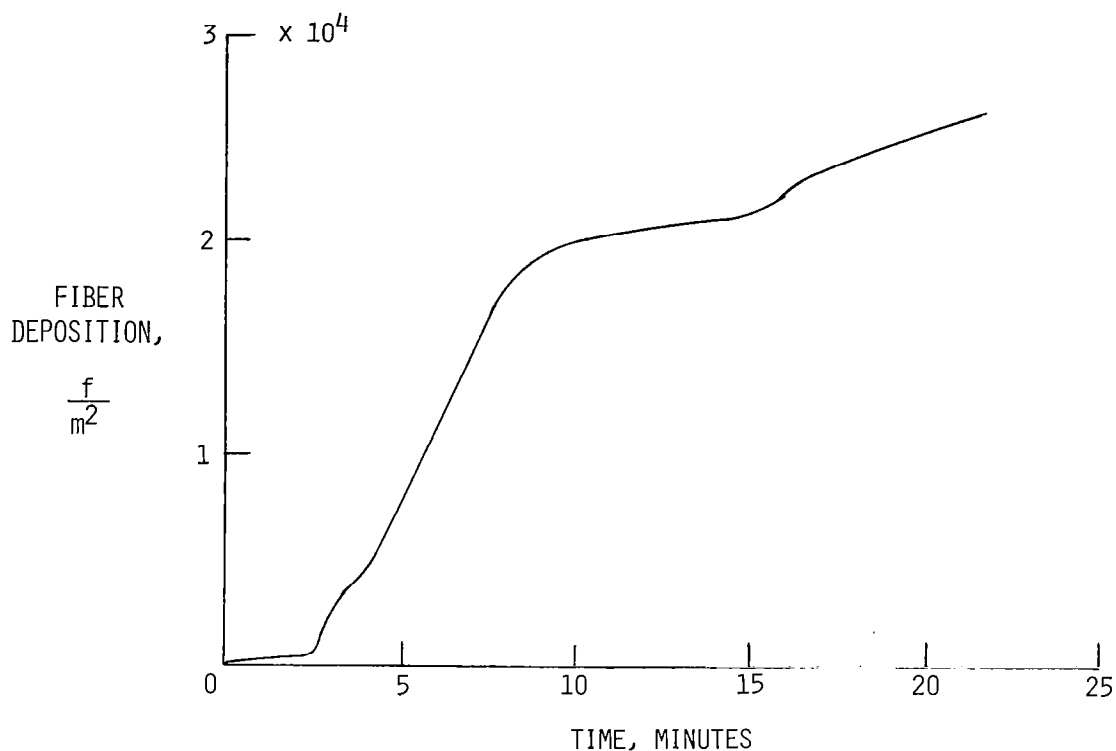

Figure 47.- Fiber counting with time from Jacob's ladder Schrader grid at Dugway outdoor fire test D-3.

TEST	CARBON FIBER MASS IN FIRE, kg	RELEASED FIBERS				SINGLE FIBERS RELEASED	
		TOTAL NUMBER	AVERAGE LENGTH mm	AVERAGE DIAMETER μm	g	%	
D-1	31.8	1.0×10^8	4.9	4.8	32	0.10	
D-2	31.8	1.4×10^8	4.3	4.5	40	0.12	
D-3	52.0	0.8×10^8	5.1	4.2	28	0.05	
S-1	34.9	2.9×10^8	2.3	4.3	45	0.13	
S-2	31.8	2.0×10^8	--	--	--	--	

Figure 48.- Preliminary estimate of single carbon fibers released at Dugway outdoor fire tests.

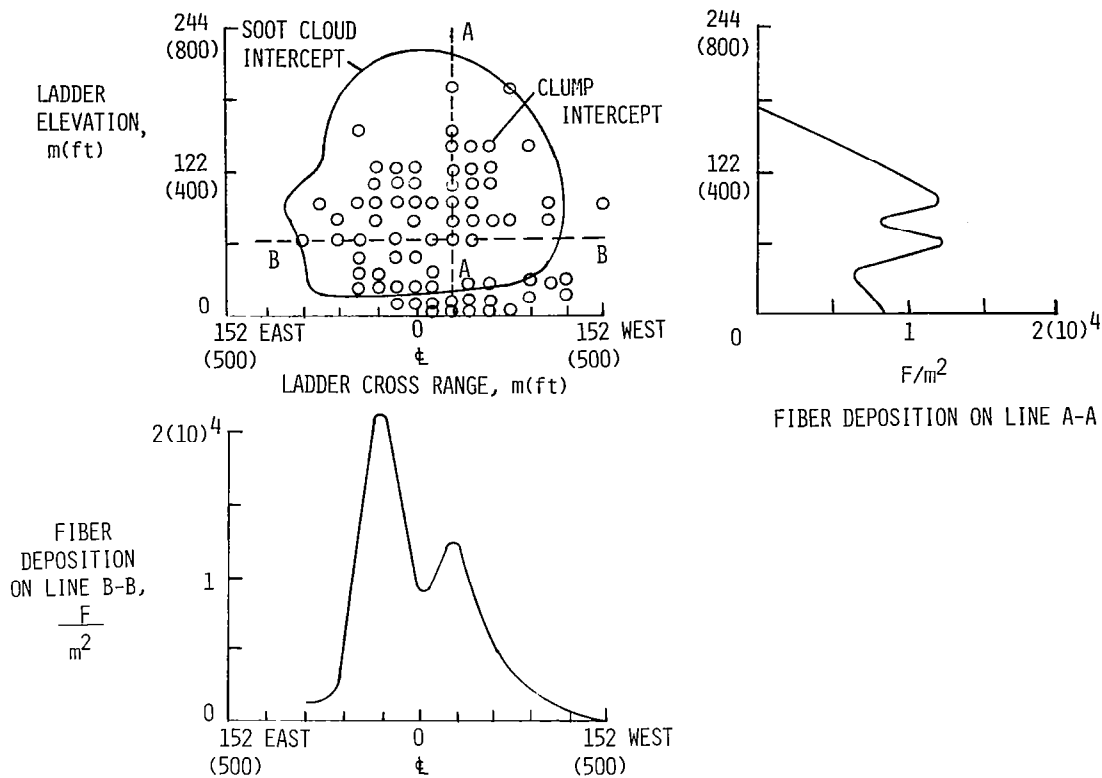

Figure 49.- Fiber counts from Jacob's ladder mesh viewgraphs at Dugway outdoor fire test D-3.

DOWN RANGE DISTANCE (METERS)	MAXIMUM EXPOSURE LEVELS (FIBER · SECS/M ³)		
	TRIAL D-1	TRIAL D-2	TRIAL D-3
200	6400	2200	3300
1000	900	1400	770
2200	180	220	550
3800	70	450	210
5500	290	490	210
10200	250	580	770
19200	290	180	130

Figure 50.- Exposure levels as a function of downwind distance.

● FIBER RELEASE

SHOCK TUBE 0.5% MAX, FORCED

OUTDOORS 0.13% MAX

∴ 1% FOR RISK CALCULATIONS IS CONSERVATIVE

● FIBER LENGTH (FIBERS GREATER THAN 1 MM AVERAGE)

SHOCK TUBE 2.0 MM AVERAGE

OUTDOORS 5.1 MM AVERAGE

∴ 3 MM USED FOR RISK CALCULATIONS IS BRACKETED

● EQUIPMENT VULNERABILITY TO FIRE-RELEASED FIBERS

- NEARLY IDENTICAL TO FIBER CHAMBER TESTS

- JUSTIFIES USE OF FIBER CHAMBER TEST DATA IN RISK CALCULATION

Figure 51.- Tentative conclusions - large scale test results.