

THERMAL ENERGY STORAGE SYSTEMS USING
FLUIDIZED BED HEAT EXCHANGERS*

V. Ramanathan, T. E. Weast, and K. P. Ananth
Midwest Research Institute - Kansas City

SUMMARY

A systems study is being conducted to determine the viability of using Fluidized Bed Heat Exchangers (FBHX) for Thermal Energy Storage (TES) in applications with potential for waste heat recovery. Of the candidate applications screened, Cement Plant Rotary Kilns and Steel Plant Electric Arc Furnaces were identified, via the chosen selection criteria, as having the best potential for successful use of FBHX/TES system. A computer model of the FBHX/TES systems has been developed and the technical feasibility of the two selected applications has been verified. Economic and trade-off evaluations are in progress for final optimization of the systems and selection of the most promising system for further concept validation.

INTRODUCTION

The development of efficient (TES) systems is necessary for many energy conservation programs to be technically and economically attractive. By utilizing the mass of a fluidized material for thermal energy storage, the energy transfer and storage functions can be integrated into a common FBHX/TES system. Systems used for recovery of sensible heat generally use either conventional tubular type exchangers or direct contact of a working fluid with a fixed storage media which require large heat transfer surface areas and may be subject to plugging of the flow by loose particles. In addition to TES, FBHX's can eliminate these potential heat transfer problems.

The objective of this project is to identify and analyze operating characteristics and economics of potential FBHX/TES systems when used for waste heat recovery and utilization. The conceptual study formulated to address this objective is divided into two major tasks. Task I defines potential FBHX concepts and identifies potential applications into which TES can be efficiently integrated. Task II evaluates the technical and economic feasibility of the two

* NASA - Lewis Research Center; Contract No. DEN 3-96.

most promising systems identified in Task I and recommends one application for additional study or demonstration.

This paper summarizes the results of Task I and the status of Task II which is still in progress. Interim conclusions and future efforts are also presented.

TASK I - FBHX CONCEPT DEFINITION, TES APPLICATION IDENTIFICATION, AND SYSTEM INTEGRATION AND SELECTION

FBHX Concept Definition

Since the TES media is the mass of the FBHX bed material, it is necessary to evaluate the numerous FBHX configurations for identification of the most effective types for TES systems. Numerous configurations of fluidized bed heat exchangers are possible. Representative FBHX configurations are depicted in Figure 1. A vertical multistage bed with countercurrent contacting is presented in Figure 1(a). In this system, solids are heated by the gas stream which is used to fluidize the bed. A fluidized bed with an internal heat exchanger is depicted in Figure 1(b). The high temperature inlet gas fluidizes the bed in this system. Crosscurrent contacting in a multistage bed is shown in Figure 1(c). Heat exchange is between the hot fluidizing gas and the bed solids. Figure 1(d) is a cross-flow system with an internal heat exchanger, in which air fluidizes the incoming hot alumina particles and heat is transferred to the cooling water circulating in the heat exchanger. Figures 1(e) and 1(f) illustrate liquid fluidized bed heat exchangers with internal heat exchangers.

The various potential fluidized bed heat exchanger/storage configurations were ranked according to such operating parameters as efficiency of heat recovery, heat transfer rate, system pressure drop, environmental problems, stability of bed operation, etc. The following conclusions were reached regarding the application of fluidized beds for energy storage:

- Fluidized beds generally require a high pressure drop and hence, their operating power requirements are high. This limits their use to rather high temperature applications where the amount of energy recovered is large relative to operating energy requirements. Therefore, liquid-fluidized beds were eliminated from further consideration for storage applications.

- When designing multistage beds, the bed stages should be kept as shallow as possible to minimize the pressure drop.

- Multistage fluidized beds, which have a larger temperature recovery effectiveness, are preferable to single stage beds; however, increasing the number of stages may also increase the total system pressure drop.

- Multistage counter flow systems have higher thermal efficiency than multistage cross flow systems with an equal number of stages. A stable flow of solids against gases can be obtained by down flow pipes or overflow weirs installed between stages. Such multistage shallow beds have successfully operated in such unit operations as continuous adsorption.

TES Application Identification

A large number of industrial processes, solar power generation, and HVAC systems were considered for potential application of FBHX for TES. Due to the large number of potential applications, they were grouped by unit process with similar waste characteristics (Table I). Thus, a selected FBHX/TES system for a unit process in one industry may also be adaptable to other industries with similar unit processes. Flow charts were obtained for the unit processes and energy balances performed in order to evaluate the potential for energy recovery.

Integration and Selection

In order to reduce the potential applications to the six most promising systems for a more detailed review, a number of criteria were selected for the processes. The criteria for this analysis were:

- Waste stream temperature $\geq 260^{\circ}\text{C}$ (500°F)
- Flow rate $\geq 283 \text{ m}^3/\text{min}$ (10,000 cfm)
- Annual energy recoverable from total industry $\geq 1.05 \times 10^{10}$ MJ/yr (10^{12} BTU/yr)
- Need for TES
- Proximity of energy source to use
- Unique benefits such as pollutant removal or reduced plugging

The six applications designated with an asterisk (*) in Table I were chosen for a more detailed review. Five additional selection criteria were then established for final screening of the six candidates. The additional criteria were:

- Adaptability to candidate process
- Growth potential of candidate process
- Relative simplicity of system when integrated with FBHX/TES

- Timeliness
- Acceptability to industry

As a result of the final screening process the cement plant rotary kiln and the steel plant electric arc furnace were chosen for detailed techno-economic evaluation.

TASK II - TECHNOECONOMIC EVALUATION

The technical aspects of the evaluation for the rotary kiln and electric arc furnace applications of FBHX/TES systems are nearly complete. Each technical evaluation included establishing a plant process flow configuration, an operational scenario, a preliminary FBHX/TES design, and parametric analysis.

The process flow configurations for each application (Figures 2 and 3) are similar in that the TES charge cycle for both designs uses hot exhaust gases to heat the bed material (sand) in a counter flow, multistage, shallow FBHX. The hot solids are then stored in an insulated structure until the energy is needed. During the TES discharge cycle the same counter flow, multistage shallow FBHX is used to heat low temperature gases for a waste heat boiler. The cooled solids are stored in another insulated structure to await the next charge cycle. The electric arc furnace application also includes a buffer FBHX/TES to smooth the short duration (2-3 hr) periodic variations in gas temperature before proceeding to the long-term FBHX/TES described above. Options to eliminate the separate buffer are presently being considered.

The initial operating scenario for the cement plant requires approximately 80% of the rotary kiln exhaust gas to be sent directly to a waste heat boiler for power generation while the remaining 20% is used to charge the TES system. During discharge, 100% of the rotary kiln gases are sent directly to the waste boiler while approximately 20% of the boiler exhaust is recycled through the FBHX/TES to recover energy and added to the kiln gases at the waste heat boiler inlet. This results in a theoretical power production swing from 80 to 120% of the nominal generating capacity without TES and allows significant if not total reduction in peak power demand.

The initial operating scenario for the steel plant requires 100% of the electric arc furnace exhaust gases to be sent to the FBHX/TES system during a charge cycle when all power is purchased at off-peak rates. When power is purchased at on-peak rates, both the TES system and the electric arc furnace gases would be available for power production and reducing peak demand.

A parametric analysis is being performed to determine the optimum FBHX/TES design. A computer model was developed to determine the effects of the number of stages, gas temperatures, gas flows, bed materials, charge discharge times, and parasitic power required for operation.

Work on the economic-analysis has been initiated. The estimated capital investment costs, annual operating costs, and unit energy costs to construct and operate each model system will be determined. Capital investment costs will represent the total investment required to construct a new system and will include direct costs, indirect costs, contractor's fees, and contingency. Annual operating costs will represent the variable, fixed, and overhead costs required to operate the systems. Unit energy costs for each model system are the annual operating cost of the system divided by the annual energy savings. All costs associated with the waste heat boiler system and the fluidized bed heat exchanger TES system will be determined separately. The total cost of the model system will equal the sum of the individual costs.

CONCLUDING REMARKS

The technical feasibility of FBHX for TES systems has been verified by analysis of two selected conceptual systems. Initial results for the cement plant rotary kiln indicate that the diversion of 20% of the kiln exhaust gases to a 5-stage FBHX/TES system during a 12-hr charge period allows power production to be increased 11% during a 12-hr discharge period. Similarly the diversion of 100% of the electric arc furnace gases during an 8-hr charge cycle of an 8-stage FBHX/TES system allows power production to be increased 34% during a 16-hr discharge period.

When the economic and trade-off analysis are concluded, we will be able to establish whether TES systems using FBHX are economically viable and if so, identify one of the systems for further study or demonstration.

TABLE 1

POTENTIAL APPLICATIONS OF FLUIDIZED BED HEAT EXCHANGERS AS A FUNCTION OF UNIT PROCESSES OR WASTE ENERGY STREAM

<u>Unit Process/Waste Energy Stream</u>	<u>Industry</u>
1. Kiln Exhaust Gases, Clinker Cooler Exhaust Gases	*Cement ** Lime Sodium Carbonate Pulp Mill Zinc Oxide Primary Aluminum Clay and Ceramic Products Phosphate Fertilizer
2. Periodic Kiln	Clay Ceramics
3. Sinter and Pellet Machine/Cooler Exhaust Gases	*Iron and Steel Primary Zinc Primary Lead
4. Electric Arc Furnace Exhaust Gases	*Iron and Steel ** Iron Foundry Steel Foundry Ferroalloy Nonferrous Foundry Secondary Nonferrous Smelting and Refining Refractories
5. Solar Brayton	*Utility
6. Reverberatory Furnace Exhaust Gases	*Primary Copper Primary Lead Nonferrous Foundry Secondary Nonferrous Smelting and Refining
7. Boilers (HVAC)	Industrial, Commercial, Residential
8. Blast Furnace Exhaust Gases	Iron Primary Lead Secondary Nonferrous Smelting and Refining
9. Dryer Exhaust Gases	Phosphate Fertilizer Clay and Ceramics Products Asphalt Paving Textile Industry Pulp and Paper Industry Food Industry (grain drying)
10a. Compressor Exhaust Air	Chemical and Allied Products Pneumatic Machinery Compressed Gas Chillers (food industry)
10b. IC Engine Exhaust Gases	Various Industries
11. Distillation Column Exhaust Streams	Chemical and Allied Products Petroleum Refining
12. Wash-down Water	Food Industry Textile Industry
13. Cupola Exhaust	Iron Foundry
14. Coke Oven	*Iron and Steel

* Six applications selected for additional study

** Two applications selected for detailed Technoeconomic Evaluation

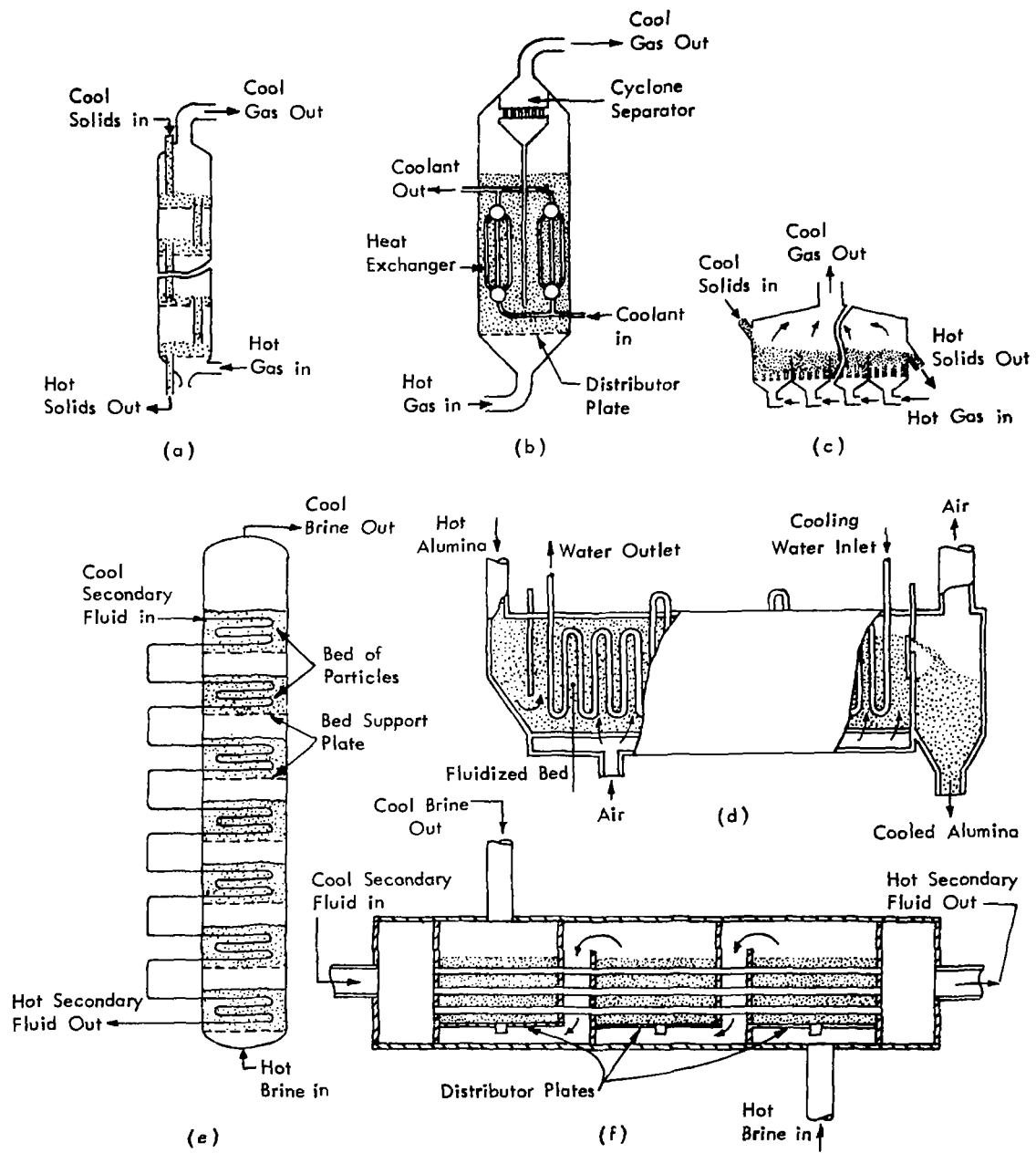

Figure 1 - Representative Configurations of Fluidized Bed Heat Exchangers

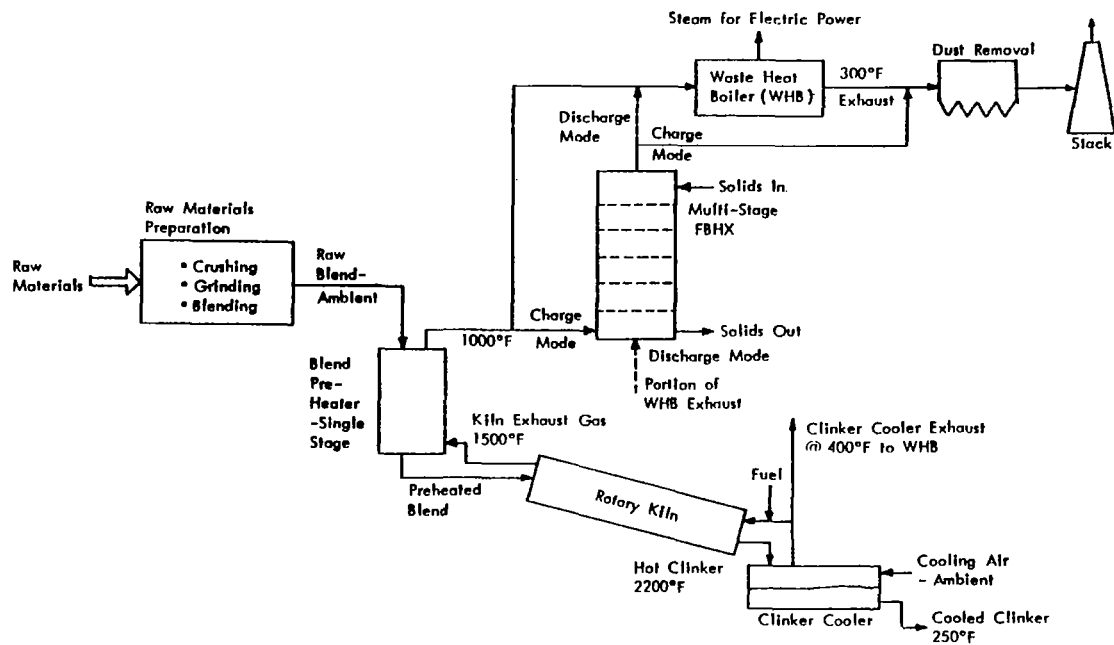

Figure 2 - Conceptual FBHX/TES System in Cement Plant Rotary Kiln

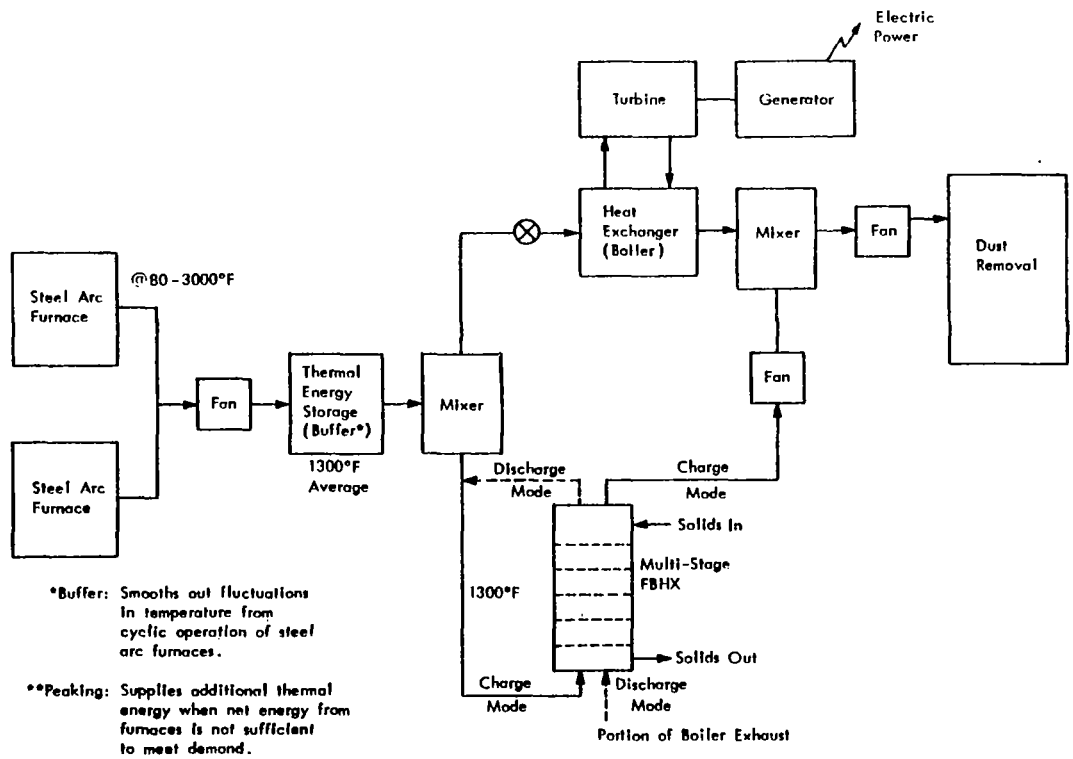

Figure 3 - Conceptual FBHX/TES System in Steel Plant Electric Arc Furnace