

NASA/FAA GENERAL AVIATION CRASH DYNAMICS PROGRAM

Robert G. Thomson, Robert J. Hayduk, and Huey D. Carden
Langley Research Center

SUMMARY

The objective of the Langley Research Center General Aviation Crash Dynamics program is to develop technology for improved crash safety and occupant survivability in general aviation aircraft. The program involves three basic areas of research: controlled full-scale crash testing, nonlinear structural analyses to predict large deflection elastoplastic response, and load attenuating concepts for use in improved seat and subfloor structure. Both analytical and experimental methods are used to develop expertise in these areas. Analyses include simplified procedures for estimating energy dissipating capabilities and comprehensive computerized procedures for predicting airframe response. These analyses are being developed to provide designers with methods for predicting accelerations, loads, and displacements on collapsing structure. Tests on typical full-scale aircraft and on full- and subscale structural components are being performed to verify the analyses and to demonstrate load attenuating concepts.

A special apparatus has been built to test Emergency Locator Transmitters (ELT's) when attached to representative aircraft structure. The apparatus is shown to provide a good simulation of the longitudinal crash pulse observed in full-scale aircraft crash tests.

INTRODUCTION

In 1972, NASA embarked on a cooperative effort with the FAA and Industry to develop technology for improved crashworthiness and occupant survivability in general aviation aircraft. The effort includes analytical and experimental work and structural concept development. The methods and concepts developed in this ongoing effort are expected to make possible future general aviation aircraft designs having enhanced survivability under specified crash conditions with little or no increase in weight and acceptable cost. The overall program is diagrammed in figure 1 with agency responsibility indicated by the legend.

Crashworthiness design technology is divided into three areas: environmental, airframe design, and component design. The environmental technology consists of acquiring and evaluating field crash data to support and validate parametric studies being conducted under controlled full-scale crash testing, the goal being to define a crash envelope within which the impact parameters allow human tolerable acceleration levels.

Airframe design has a twofold objective: to assess and apply current, on-the-shelf, analytical methods to predict structural collapse; and to develop and validate new and advanced analytical techniques. Full-scale tests are also used to verify analytical predictions, as well as to demonstrate improved load attenuating design concepts. Airframe design also includes the validation of novel load-limiting concepts for use in aircraft subfloor designs.

Component design technology consists of exploring new and innovative load-limiting concepts to improve the performance of the seat and occupant restraint systems by providing for controlled seat collapse while maintaining seat/occupant integrity. Component design also considers the design of non-lethal cabin interiors.

Langley's principal research areas in the joint FAA/NASA Crash Dynamics program are depicted pictorially in figure 2. These areas include full-scale crash testing, nonlinear crash impact analyses, and crashworthy seat and subfloor structure concept development. Subsequent sections deal with these topics, as well as Emergency Locator Transmitter (ELT) testing.

FULL-SCALE CRASH TESTING

Full-scale crash testing is performed at the Langley Impact Dynamics Research Facility (ref. 1) shown in figure 3. This facility is the former lunar landing research facility modified for free-flight crash testing of full-scale aircraft structures and structural components under controlled test conditions. The basic gantry structure is 73 m (240 ft) high and 122 m (400 ft) long supported by three sets of inclined legs spread 81 m (267 ft) apart at the ground and 20 m (67 ft) apart at the 66 m (218 ft) level. A movable bridge with a pullback winch for raising the test specimen spans the top and traverses the length of the gantry.

Test Method

The aircraft is suspended from the top of the gantry by two swing cables and is drawn back above the impact surface by a pullback cable. An umbilical cable, used for data acquisition, is also suspended from the top of the gantry and connects to the top of the aircraft. The test sequence is initiated when the aircraft is released from the pullback cable, permitting the aircraft to swing pendulum style into the impact surface. The swing cables are separated from the aircraft by pyrotechnics just prior to impact, freeing the aircraft from restraint. The umbilical cable remains attached to the aircraft for data acquisition, but it also separates by pyrotechnics before it becomes taut during skid out. The separation point is held relatively fixed near the impact surface, and the flight path angle is adjusted from 0° to 60° by changing the length of the swing cable. The height of the aircraft above the impact surface at release determines the impact velocity which can be varied from 0 to 26.8 m/s (60 mph). The movable bridge allows the pullback point to

be positioned along the gantry to insure that the pullback cables pass through the center of gravity and act at 90° to the swing cables.

To obtain flight path velocities in excess of 26.8 m/s (60 mph) a velocity augmentation method has been devised which uses wing-mounted rockets to accelerate the test specimen on its downward swing. As shown in figure 4, two Falcon rockets are mounted at each engine nacelle location and provide a total thrust of 77 850 N. The aircraft is released after rocket ignition, and the rockets continue to burn during most of the downward acceleration trajectory but are dormant at impact. The velocity augmentation method provides flight path velocities from 26.8 to 44.7 m/s (60 to 100 mph) depending on the number and burn time of rockets used.

Instrumentation

Data acquisition from full-scale crash tests is accomplished with extensive photographic coverage, both interior and exterior to the aircraft using low-, medium-, and high-speed cameras and with onboard strain gages and accelerometers. The strain gage type accelerometers (range of 250 g and 750 g at 0 to 2000 Hz) are the primary data-generating instruments, and are positioned in the fuselage to measure accelerations both in the normal and longitudinal directions to the aircraft axis. Instrumented anthropomorphic dummies (National Highway Traffic Safety Administration Hybrid II) are onboard all full-scale aircraft tests conducted at LaRC. The location and framing rate of the cameras are discussed in reference 1. The restraint system arrangement and type of restraint used vary from test to test.

Test Conducted

A chronological summary of the full-scale crash tests conducted at the Impact Dynamics Research Facility is represented in figure 5. The shaded symbols are crash tests that have been conducted, the open symbols are planned crash tests. Different symbols represent different types of aircraft under different impact conditions, for example the □ represents a twin-engine specimen impacting at 26.8 m/s (60 mph) while the ◇ represents the same twin-engine specimen, using the velocity augmentation method, impacting at 40.2 m/s (90 mph). Various types of aircraft have been successfully crash tested at LaRC from 1974 through 1978 including CH-47 helicopters, high and low wing single-engine aircraft, and aircraft fuselage sections. Data from these tests are presented in references 2 to 4. The aircraft fuselage section tests are vertical drop tests conducted to simulate full-scale aircraft cabin sink rates experienced by twin-engine aircraft tested earlier. The response of the aircraft section, two passenger seats, and two dummies are being simulated analytically (see "Nonlinear Crash Impact Analysis"). Some single-engine crash tests were conducted using a dirt impact surface while most crash tests were conducted on a concrete surface. The dirt embankment was 12.2 m (40 ft) wide, 24.4 m (80 ft) long, and 1.2 m (4 ft) in depth. The dirt was packed to the consistency of a ploughed field. The variation of full-scale crash test parameters is not complete and does not consider such secondary effects as aircraft sliding, overturning, cartwheeling, or tree and obstacle impact.

Controlled-Crash Test and Las Vegas Accident

On August 30, 1978, a twin-engine Navajo Chieftain, carrying a pilot and nine passengers crash landed in the desert shortly after taking off from the North Las Vegas Airport. All ten persons on board were killed. A comparative study of this Navajo Chieftain crash and a similar NASA controlled-crash test was made. The purposes of the study were to compare damage modes and estimate acceleration levels in the Chieftain accident with Langley tests and to assess the validity of Langley's full-scale crash simulation. The controlled-crash test chosen employed the velocity augmentation method wherein the aircraft research a flight path velocity of 41.4 m/s (92.5 mph) at impact. The pitch angle was -12° , with a 5° left roll and 1° yaw. Figure 6 shows photographs of the two aircraft. The NASA specimen is a twin-engine pressurized Navajo, which carries from six to eight passengers, and although the cabin is shorter in length, it is similar in structural configuration to the Chieftain.

Structural damage to the seats and cabin of the Navajo Chieftain and to the seats and cabin of the NASA test specimen are shown for illustrative purposes in figure 7. Much more corroborating structural damage is discussed in reference 5. The Chieftain apparently contacted the nearly level desert terrain at a location along the lower fuselage on the right side opposite the rear door. An instant later, the rest of the fuselage and the level right wing impacted. The Chieftain's attitude just prior to impact was concluded to have been the following: pitched up slightly, rolled slightly to the right and yawed to the left. The two aircraft differ in roll attitude at impact but are comparable. The structural damage to the cabin of the Chieftain was much greater than that exhibited by the NASA controlled-crash test under correspondingly similar impact attitudes. The damage pattern to the standard passenger and crew seats of the Chieftain was similar to that in the NASA tests, but generally exhibited more severe distortion. The damage patterns suggests similar basic failure modes and in the case of the seat distortion of flight impact velocity in excess of 41.4 m/s (92.5 mph) for the Chieftain. Acceleration time histories from the first passenger seat and floor of the NASA controlled-crash test are shown in figure 8 where the first passenger seat corresponds to the damaged seat shown in figure 7.

Because of the similarity in the damage, patterns exhibited by seats 6 and 8 of the Chieftain and the first passenger seat of the NASA controlled test, generalized conclusions can be drawn relative to certain seat accelerations experienced by those passengers in the Chieftain. The peak pelvic accelerations of passengers 6 and 8 in the Chieftain accident were probably in excess of 60 g's normal (to aircraft axis), 40 g's longitudinal, and 10 g's transverse.

NONLINEAR CRASH IMPACT ANALYSIS

The objective of the analytical efforts in the crash dynamics program is to develop the capability to predict nonlinear geometric and material behavior

of sheet-stringer aircraft structures subjected to large deformations and to demonstrate this capability by determining the plastic buckling and collapse response of such structures under impulsive loadings. Two specific computer programs are being developed, one focused on modeling concepts applicable to large plastic deformations of realistic aircraft structural components, and the other a versatile seat/occupant program to simulate occupant response. These two programs are discussed in the following sections.

Plastic and Large Deflection Analysis of Nonlinear Structures (PLANS)

Description

For several years LaRC has been developing a sophisticated structural analysis computer program which includes geometric and material nonlinearities (refs. 6 and 7). "PLANS" is a finite element program for the static and dynamic nonlinear analysis of aircraft structures. PLANS computer program is capable of treating problems which contain bending and membrane stresses, thick and thin axisymmetric bodies, and general three-dimensional bodies. PLANS, rather than being a single comprehensive computer program, represents a collection of special purpose computer programs or modules, each associated with a distinct class of physical problems. Using this concept, each module is an independent finite element computer program with its associated element library. All the programs in PLANS employ the "initial strain" concept within an incremental procedure to account for the effect of plasticity and include the capability for cyclic plastic analysis. The solution procedure for treating material nonlinearities (plasticity) alone reduces the nonlinear material analysis to the incremental analysis of an elastic body of identical shape and boundary conditions, but with an additional set of applied "pseudo loads." The advantage of this solution technique is that it does not require modification of the element stiffness matrix at each incremental load step. Combined material and geometric nonlinearities are included in several of the modules and are treated by using the "updated" or convected coordinate approach. The convected coordinate approach, however, requires the reformation of the stiffness matrix during the incremental solution process. After an increment of load has been applied, increments of displacement are calculated and the geometry is updated. In addition to calculating the element stresses, strains, etc., the element stiffness matrices and mechanical load vector are updated because of the geometry changes and the presence of initial stresses. A further essential ingredient of PLANS is the treatment of dynamic nonlinear behavior using the DYCAST module. DYCAST incorporates various time-integration procedures, both explicit and implicit, as well as the inertia effects of the structure.

Comparison With Experiment

PLANS is currently being evaluated by comparing calculations with experimental results on simplified structures, such as a circular cylinder, a tabular frame structure, an angular frame with joint eccentricities, and the

same angular frame covered with sheet metal. Static and dynamic analyses of these structures loaded into the large deflection plastic collapse regime have been conducted with PLANS and compared with experimental data in references 8 and 9.

An analytical simulation of a vertical drop test of an aircraft section has recently been compared with experimental full-scale crash data in reference 10. Figure 9 shows the fuselage section prior to testing and figure 10 shows the DYCAST finite element fuselage, seat, and occupant model. The vertical impact velocity of the specimen was 8.38 m/s (27.5 fps). The 50-percentile anthropomorphic dummies each weighed 74.8 kg (165 lb). The occupant pelvis vertical accelerations compared with analysis are shown in figure 11. The DYCAST and ACTION models predicted an accurate mean pelvis acceleration level. The computer program KRASH gave better results with several masses representing the lower and upper torso and predicts an oscillatory response similar to that exhibited by the test.

Modified Seat Occupant Model for Light Aircraft (MSOMLA)

Description

Considerable effort is being expended in developing a good mathematical simulation of occupant, seat, and restraint system behavior in a crash situation. MSOMLA was developed from a computer program SOMLA funded by the FAA as a tool for use in seat design (ref. 11). SOMLA is a three-dimensional seat, occupant, and restraint program with a finite element seat and an occupant modeled with twelve rigid segments joined together by rotational springs and dampers at the joints. The response of the occupant is described by Lagrange's equations of motion with 29 independent generalized coordinates. The seat model consists of beam and membrane finite elements.

SOMLA was used previously to model a standard seat and a dummy occupant in a NASA light aircraft section vertical drop test. During this simulation, problems were experienced with the seat model whenever the yield stress of an element was exceeded. Several attempts to correlate various finite element solutions of the standard seat with OPLANE-MG, DYCAST, and SOMLA using only beam and membrane elements, to experimental data from static vertical seat loading tests were only partially successful. Consequently, to expedite the analysis of the seat/occupant, the finite element seat in SOMLA was removed and replaced with a spring-damper system. Additional modifications to SOMLA added nonrigid occupant contact surfaces (nonlinear springs) and incorporated a 3-D computer graphics display. This modified SOMLA is called MSOMLA. A more complete discussion of MSOMLA, its computer input requirements, and additional comparisons of experiments and analysis can be found in reference 12.

Comparison With Experiment

A comparison of full-scale crash test data from the -30° , 26.8 m/s (60 mph) crash test and occupant simulation using MSOMLA is presented in figure 11 in two-dimensional graphics. Although three-dimensional graphics are available in MSOMLA, only two-dimensional graphics were chosen for the pictorial comparison in figure 12. Note the similarity between the response of the occupant in the simulation and the occupant as seen through the window of the aircraft during crash test. Note also that in the simulation, the dummy's head passes through the back of the seat in front of him, a fact that could explain differences in the computed and measured head accelerations as presented in figure 13. The comparisons of this figure, between measured and computed acceleration pulses are excellent, considering the seat and occupant were subjected to forward, normal, and rotational accelerations. This comparison, using full-scale crash data, demonstrates the versatility of the program's simulation capability.

CRASHWORTHY SEAT AND SUBFLOOR STRUCTURE CONCEPTS

The development of structural concepts to limit the load transmitted to the occupant is another research area in LaRC's crashworthiness program. The objective of this research is to attenuate the load transmitted by a structure either by modifying its structural assembly, changing the geometry of its elements, or adding specific load-limiting devices to help dissipate the kinetic energy. Recent efforts in this area at LaRC have concentrated on the development of crashworthy aircraft seat and subfloor systems.

The concept of available stroke is paramount in determining the load attenuating capabilities of different design concepts. Shown in figure 14 are the three load attenuating areas which exist between an occupant and the impact surface during vertical descent: the landing gear, the cabin subfloor, and the aircraft seat. Attenuation provided by the landing gear will not be included in this discussion since it is more applicable to helicopter crash attenuators. Using the upward human acceleration tolerance of 25 g as established in ref. 13, a relationship between stroke and vertical descent velocity can be established for a constant stroking device which fully strokes in less than the maximum time allowable (0.10 s) for human tolerance. This relationship is illustrated in fig. 14. Under the condition of a constant 25 g deceleration stroke the maximum velocity decrease for the stroking available is 12.2 m/s (40 fps) for the seats and 8.2 m/s (27 fps) for the subfloor (assuming 30 cm (12 in.) and 15 cm (6 in.) in general for a twin-engine light aircraft). For a combination of stroking seat and stroking subfloor the maximum velocity decrease becomes 15.2 m/s (50 fps). These vertical sink rates are comparable to the Army Design Guide recommendations (ref. 13) for crashworthy seat design.

Seat

Figure 15 shows a standard passenger and three load-limiting passenger seats that were developed by the NASA and tested at the FAA's Civil Aeromedical Institute (CAMI) on a sled test facility. The standard seat is typical of those commonly used in some general aviation airplanes and weighs approximately 11 kg (25 lbm). The ceiling-mounted load-limiting seat is similar in design to a troop seat designed for Army helicopters (ref. 14) and weighs 9 kg (20 lbm). This seat is equipped with two wire bending load limiters which are located inside the seat back and are attached to the cabin ceiling to limit both vertical and forward loads. Two additional load limiters are attached diagonally between the seat pan at the front and the floor at the rear to limit forward loads only. The seat pan in the design remains parallel to the floor while stroking. The length of the stroke is approximately 30 cm (12 inches) in the vertical direction and 18 cm (7 inches) forward (fig. 16(a)). The components of a wire bending load limiter are shown in the photograph of fig. 17. In operation, the wire bending trolley, which is attached to the top housing sleeve, translates the wire loop along the axis of the wire during seat stroking at a constant force. This type of load limiter provides a near constant force during stroking thus making it possible to absorb maximum loads at human tolerance levels over a given stroking distance.

The floor-mounted load-limiting seat weighs 10 kg (23 lbm) and employs two wire bending load limiters which are attached diagonally between the seat pan at the top of the rear strut and the bottom of the front legs. While stroking, the rear struts pivot on the floor thus forcing the load-limiter housing to slide up inside the seat back (fig. 16(b)). The third load-limiting concept tested uses a rocker swing stroke to change the attitude of the occupant from an upright seated position to a semisupine position.

In the dynamic tests conducted at CAMI, the sled or carriage is linearly accelerated along rails to the required velocity and brought to rest by wires stretched across the track in a sequence designed to provide the desired impact loading to the sled. A hybrid II, 50 percentile dummy instrumented with accelerometers loaded the seats and restraint system on impact. The restraint system for these seats consisted of a continuous, one-piece, lap belt and double shoulder harness arrangement.

Time histories of dummy pelvis accelerations recorded during two different impact loadings are presented in figure 18 with the dummy installed in a standard seat and in a ceiling-mounted load-limiting seat. The vertical impulse of figure 18(a) positioned the seats (and dummy) to impact at a pitch angle (angle between dummy spine and direction of sled travel) of -30° and roll angle of 10° . In the "longitudinal" pulse (fig. 18(b)) the seats were yawed 30° to the direction of sled travel. The sled pulses are also included in the figure and represent the axial impulse imparted to the inclined dummies. The X and Z axes of the dummy are local axes perpendicular and parallel to its spine, respectively. The figure shows that for both

impact conditions the load-limiting seat in general provide a sizeable reduction in pelvis acceleration over those recorded during similar impacts using the standard seat.

The impact condition associated with a dummy passenger in one of the full-scale NASA crash tests were quite similar to those defined by the sled test of figure 18(a), particularly in terms of velocity change, thereby permitting a gross comparison of their relative accelerations. Figure 19 shows that comparison. The dummy accelerations traced from the two tests are similar in both magnitude and shape, however some phase shift is evident. This agreement suggests that sled testing provides a good approximation of dummy/seat response in full-scale aircraft crashes.

Subfloor Structure

The subfloor structure of most medium size general aviation aircraft offers about 15-20 cm (6-8 in) of available stroking distance which suggests the capability to introduce a velocity change of approximately 8.2 m/s (27 fps) (see fig. 14). Aside from the necessary space for routing hydraulic and electrical conducts, considerable volume is available within the subfloor for energy dissipation through controlled collapse. A number of energy absorbing concepts have been advanced and figure 20 presents sketches of five prominent candidates. The first three concepts, moving from left to right, would replace existing subfloor structure and allow for (a) the metal working of floor beam webs filled with energy dissipating foam, (b) the collapsing of precorrugated floor beam webs filled with foam, or (c) the collapsing of precorrugated foam-filled webs interlaced with a notched lateral bulkhead. The remaining two concepts eliminate the floor beam entirely and replace it with a precorrugated canoe (the corrugations running circumferentially around the cross section) with energy dissipation foam exterior to the canoe, and foam-filled Kevlar cylinders supporting the floor loads. These five promising concepts have been tested both statically and dynamically to determine their load-deflection characteristics. Some examples of the static load-deflection behavior obtained from four of the five concepts are shown in figure 21.

A number of energy absorbing subfloor specimens were constructed using the results of the concept study. Each of the sections could replace existing subfloor structure and would consist of a relatively strong upper floor for maintaining seat-to-aircraft integrity and a crush zone to allow for a more uniform collapse and distribution of load. These five subfloors have been tested statically and their load-deflection characteristics are shown in figure 22 along with results for a comparable unmodified subfloor structure.

The unmodified subfloor load-deflection characteristics indicate several sudden substantial losses in load carrying capability which were the results of undesirable loss of structural integrity, that is, the seat rails broke loose, the floor webs and floor covering ripped free from the floor beams. On the other hand, the results for the five new concepts indicate that they perform well in that the the upper floor remained intact throughout the loading and did not break apart. Some concepts did, however, collapse with more desirable load-deflection characteristics than others. For example, the

result for the corrugated beams with notched corner web attachments, as shown in more detail in figure 23, indicate that the crush zone collapsed at a more desirable lower (essentially) constant load characteristic than the unmodified structure while the energy absorbed at the reduced crushing load was essentially the same as the unmodified subfloor. Dynamic vertical tests of all the load-limiting aircraft sections are currently being conducted at vertical velocities up to 7.3 m/s (24 fps) to evaluate their impact performance as compared to unmodified subfloor structure.

Emergency Locator Transmitter (ELT) Tests

General aviation airplanes are required to carry an Emergency Locator Transmitter (ELT) (normally crash activated) to expedite the location of crash aircraft by searchers. However, the ELT is plagued with many problems that severely limited the usefulness of these potentially life-saving devices. The National Transportation Safety Board recently reviewed the ELT problems and efforts to find solutions (ref. 15). The ELT has a high rate of nondistress activation and failure to activate in a crash situation. Suspected problem sources are, among others, improper mounting, the location in the aircraft, short circuits, vibration sensitivity, battery failures, and antenna location. NASA Langley is assisting the FAA and industry through Radio Technical Commission for Aeronautics (RTCA) Special Committee 136 formed to study in depth the ELT problems and to seek solutions.

NASA Langley is demonstrating ELT sensor activation problems by mounting a sampling of ELT specimens in full-scale crash test aircraft and in a special test apparatus to simulate longitudinal crash pulses. This very definitive demonstration of some specific ELT performance problems and evaluation of the test results will increase understanding and lead to solutions. Langley is also studying the antenna radiation problem by fly-over examination of the radiation patterns emanating from ELT's mounted in situ.

An apparatus has been constructed to permit laboratory tests to be conducted on ELT's in a realistic environment. The test setup, shown in figure 24, consists of a large cylindrical section with an actual airplane tail section mounted in its interior. Wedges attached to the test apparatus shape the "crash" pulse upon impact in a bed of glass beads. The cylinder can be rotated relative to the wedges to vary the vector inputs. Decelerations at the base of the airplane section, responses of the bulkheads and webs, and the response of the ELT are recorded along with activation/no activation signals.

The test apparatus permits an extension of test data on ELT's acquired during crash tests of full-size aircraft at the Impact Dynamics Facility. For example, the data in figure 25 is a comparison of the longitudinal deceleration on an ELT in a recent crash test with a simulated crash pulse in the test rig. As indicated in the figure, both the characteristic shape of the crash pulse and structural resonances are reproduced by the test apparatus. A representative sampling of in-service ELT's tests in this apparatus is discussed in reference 16.

CONCLUDING REMARKS

Langley Research Center (LaRC) has initiated a crash safety program that will lead to the development of technology to define and demonstrate new structural concepts for improved crash safety and occupant survivability in general aviation aircraft. This technology will make possible the integration of crashworthy structural design concepts into general aviation design methods and will include airframe, seat, and restraint-system concepts that will dissipate energy and properly restrain the occupants within the cabin interior. Current efforts are focused on developing load-limiting aircraft components needed for crash load attenuation in addition to considerations for modified seat and restraint systems as well as structural airframe reconfigurations. The dynamic nonlinear behavior of these components is being analytically evaluated to determine their dynamic response and to verify design modifications and structural crushing efficiency. Seats and restraint systems with incorporated deceleration devices are being studied that will limit the load transmitted to the occupant, remain firmly attached to the cabin floor, and adequately restrain the occupant from impact with the cabin interior. Full-scale mockups of structural components incorporating load-limiting devices are being used to evaluate their performance and provide corroboration to the analytical predictive techniques.

In the development of aircraft crash scenarios, a set of design crash parameters are to be determined from both FAA field data and LaRC controlled-crash test data. The controlled-crash test data will include crashes at velocities comparable with the stall velocity of most general aviation aircraft. Close cooperation with other governmental agencies is being maintained to provide inputs for human tolerance criteria concerning the magnitude and duration of deceleration levels and for realistic crash data on survivability. The analytical predictive methods developed herein for crash analyses are to be documented and released through COSMIC.

A new Emergency Locator Transmitter (ELT) test apparatus has been made operational at NASA Langley Research Center. Testing of a representative sample of in-service ELT's is underway. Results of this study will form the basis for specific recommendations by Radio Technical Commission for Aeronautics (RTCA) Special Committee 136. These recommendations to the FAA and Industry will lead to improvements in ELT reliability.

REFERENCES

1. Vaughan, Victor L; and Alfaro-Bou, Emilio: Impact Dynamics Research Facility for Full-Scale Aircraft Crash Testing. NASA TN D-8179, 1976.
2. Castle, Claude B.: Full-Scale Crash Test of a CH-47 Helicopter. NASA TM X-3412, 1976.
3. Alfaro-Bou, Emilio; and Vaughan, Victor L.: Light Airplane Crash Tests at Impact Velocities of 13 and 27 m/sec. NASA TP-1042, 1977.1977.
4. Castle, Claude B.; and Alfaro-Bou, Emilio: Light Airplane Crash Tests at Three Flight-Path Angles. NASA TP-1210, 1978.1978.
5. Hayduk, Robert J.: Comparative Analysis of PA-31-350 Chieftain (N44LV) Accident and NASA Crash Test Data. NASA TM-80102, 1979.
6. Pifko, A.; Levine, H. S.; Armen, H., Jr.: PLANS - A Finite Element Program for Nonlinear Analysis of Structures - Volume I - Theoretical Manual. NASA CR-2568, 1975. 975.
7. Pifko, A.; Armen, H., Jr.; Levy, A.; and Levine, H.: PLANS - A Finite Element Program for Nonlinear Analysis of Structures - Volume II - User's Manual. NASA CR-145244, 1977.977.
8. Thomson, R. G.; and, Goetz, R. C.: NASA/FAA General Aviation Crash Dynamics Program - A Status Report. AIAA/ASME/ASCE/AHS 20th Structures, Structural Dynamics, and Materials Conference, St. Louis, MO, April 4-6, 1979, AIAA Paper No. 79-0780.
9. Winter, Robert; Pifko, Allan B.; and Armen, Harry, Jr.: Crash Simulation of Skin-Frame Structures Using a Finite Element Code. SAE Business Aircraft Meeting, Wichita, KS, March 29-April 1, 1977, SAE paper 770484.
10. Hayduk, Robert J.; Thomson, Robert G.; Wittlin, Gil; and Kamat, Manohar P: Nonlinear Structural Crash Dynamics Analyses. SAE Business Aircraft Meeting, Wichita, KS, April 3-6, 1979, SAE Paper 790588.
11. Laananen, David H.: Development of a Scientific Basis for Analysis of Aircraft Seating Systems. FAA-RD-74-130, Jan. 1975.
12. Fasanella, Edwin L.: NASA General Aviation Crashworthiness Seat Development, SAE Business Aircraft Meeting, Wichita, KS, 1979.
13. Dynamic Science Report: Crash Survival Design Guide. USAAMRDL TR-71-22, Ft. Eustis, VA, 1971.
14. Reilly, M. J.: Crashworthy Troop Seat Investigation. USAAMRDL TR-74-93, Ft. Eustis, VA, 1974

15. Anon.: Emergency Locator Transmitters; An Overview. National Transportation Safety Board Special Study, Report NTSB-AAS-78-1, January 26, 1978.
16. Carden, Huey D.: Evaluation of Emergency-Locator-Transmitter Performance in Real and Simulated Crash Tests. 1980 Aircraft Safety and Operating Problems, NASA CP-2170, 1981.(Paper 35 of this compilation.)

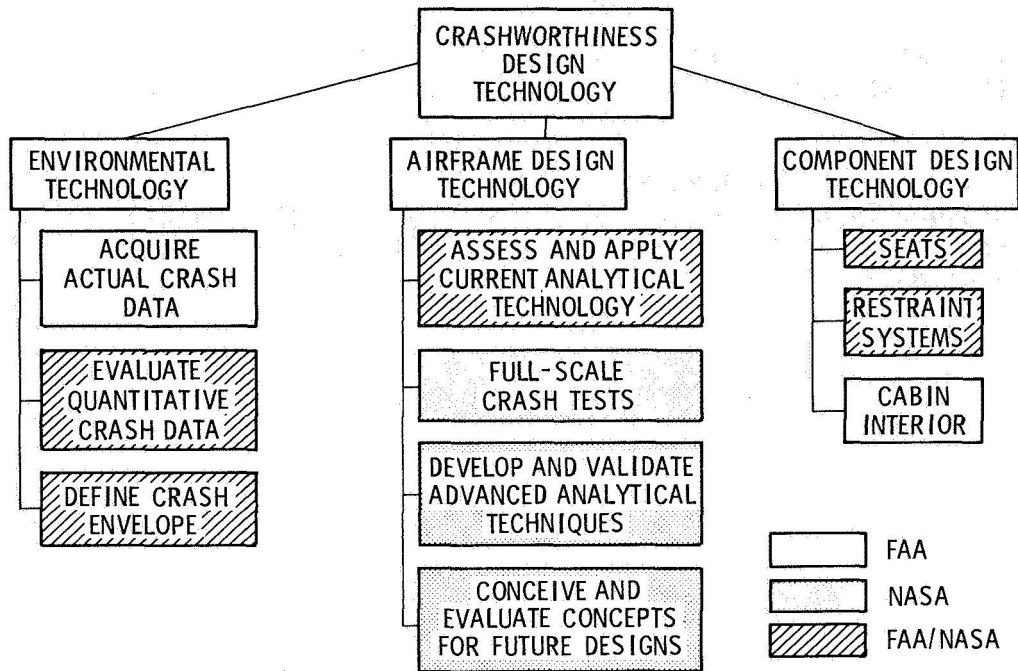

Figure 1.- Agency responsibilities in joint FAA/NASA General Aviation Crashworthiness program.

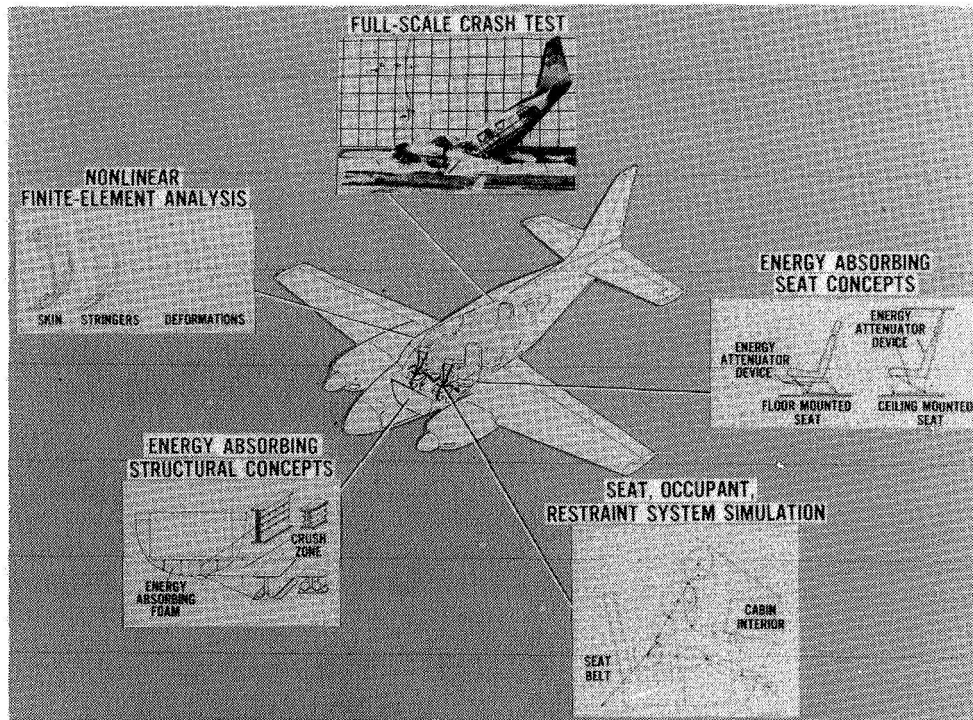

Figure 2.- Research areas in LaRC General Aviation Crash Dynamics program.

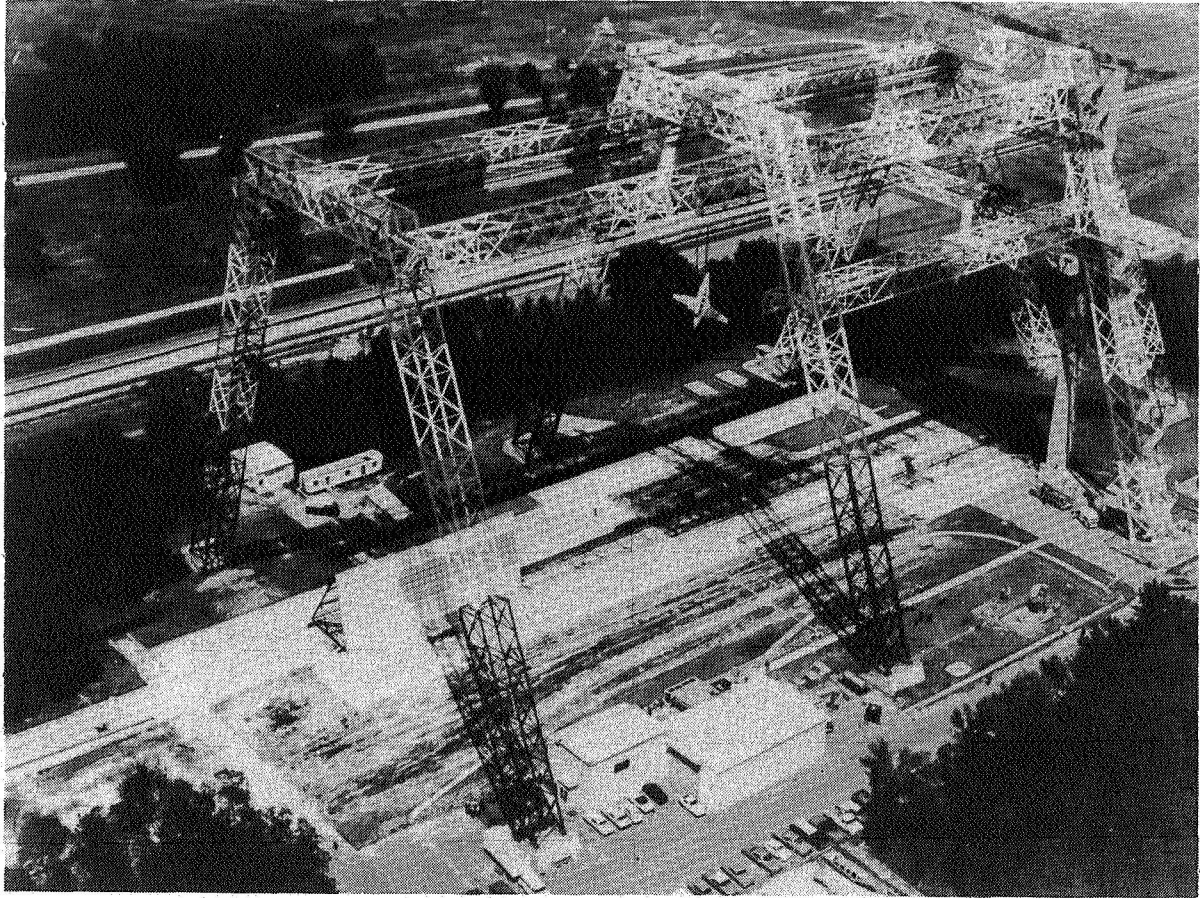
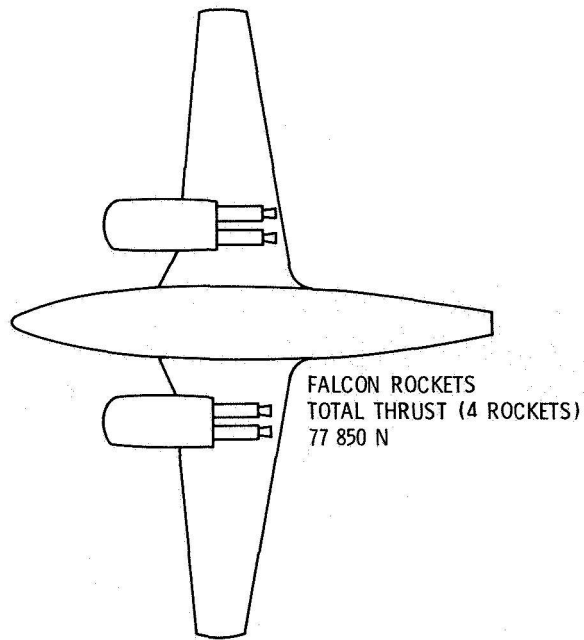

Figure 3.- Langley Impact Dynamics Research Facility.



(a) Schematic of rocket location.



(b) Photograph of rocket ignition during test.

Figure 4.- Velocity augmentation crash test method.

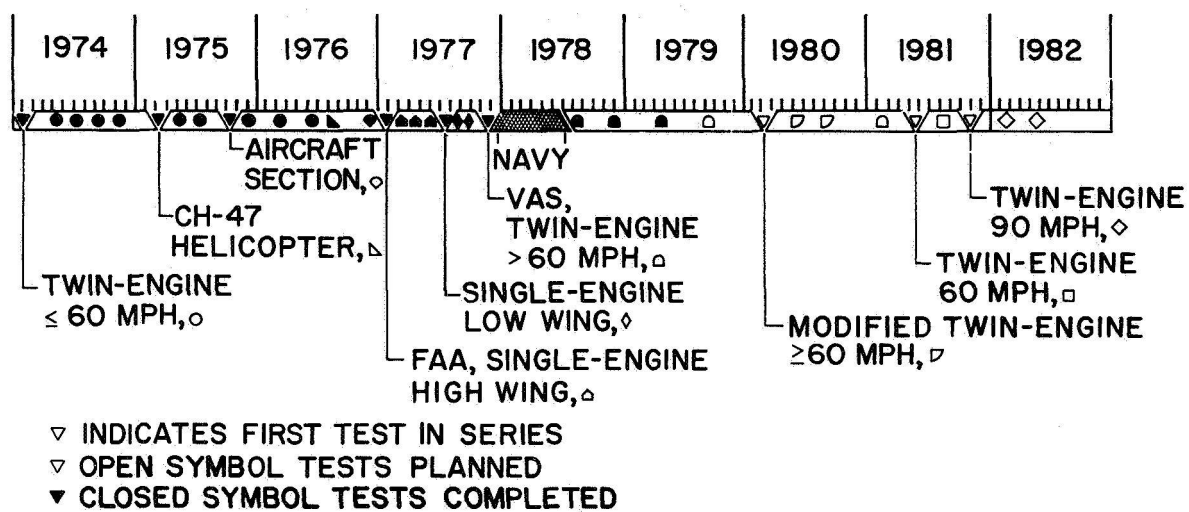

Figure 5.- General aviation crash test schedule. (1 mph = 0.45 m/s.)



(a) Controlled crash.



(b) Las Vegas accident.

Figure 6.- Controlled-crash test and Las Vegas accident.

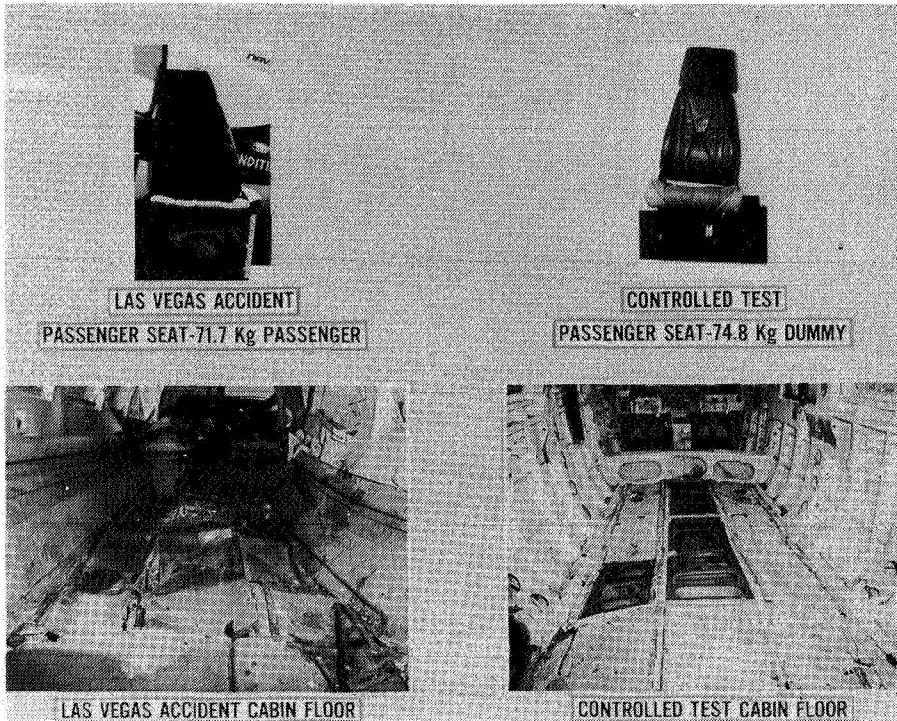

Figure 7.- Damage comparison between controlled test and Las Vegas accident.

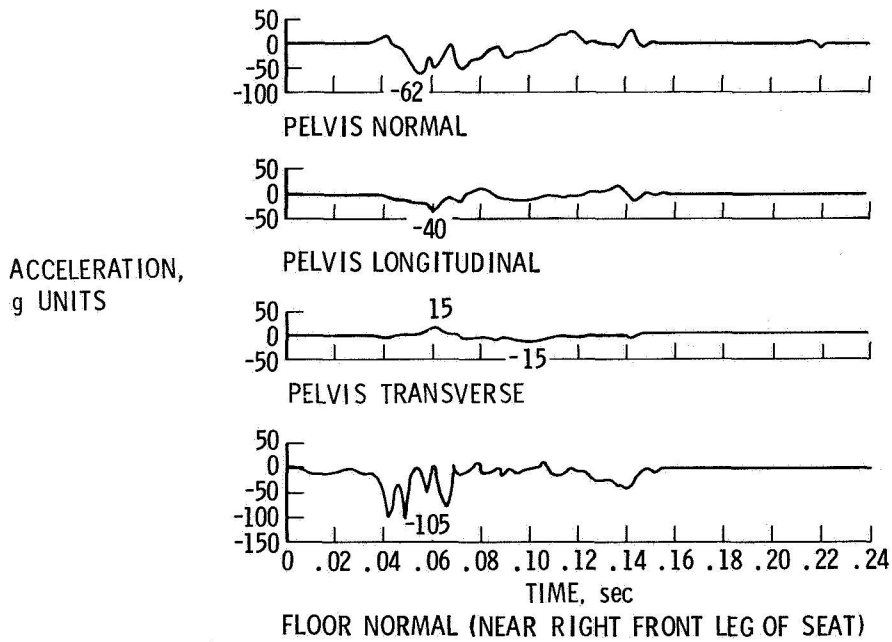

Figure 8.- Acceleration time histories from first passenger and floor of controlled-crash test (-12° pitch, 41.4 m/s flight path velocity with 5° left roll, 1° yaw).

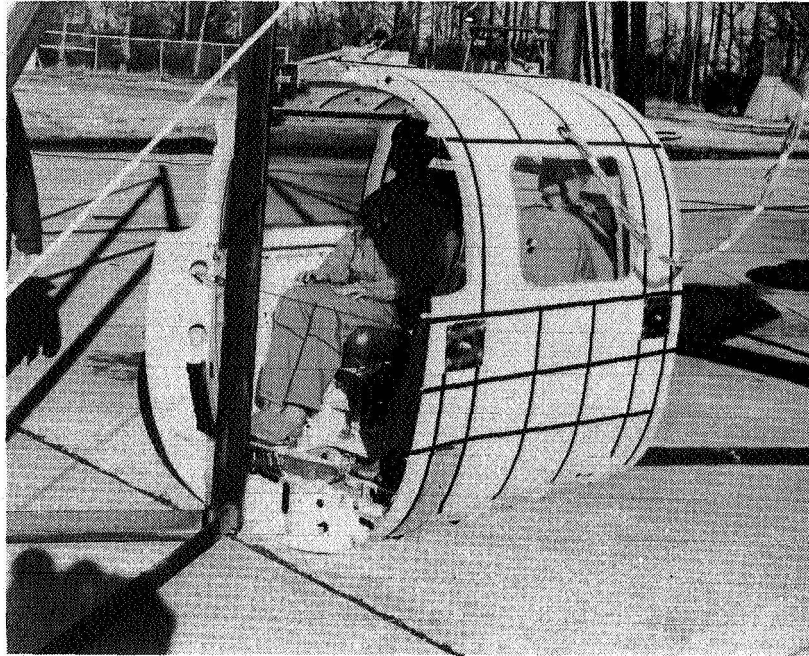

Figure 9.- Fuselage section drop-test specimen.

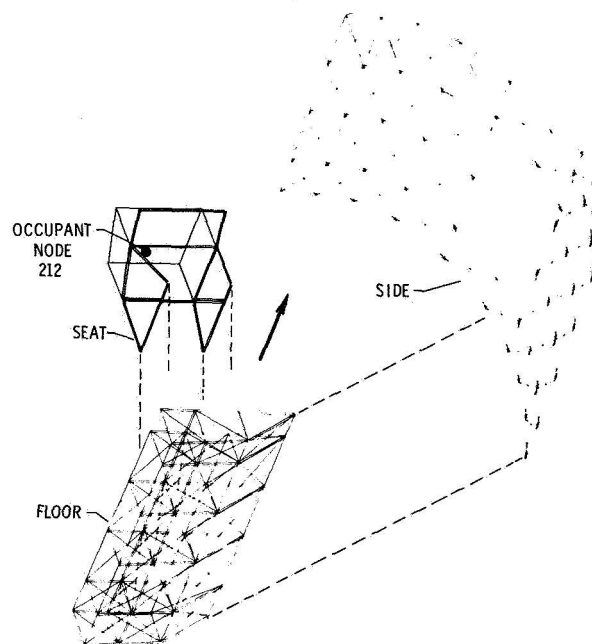

Figure 10.- DYCAST fuselage, seat, and occupant model.

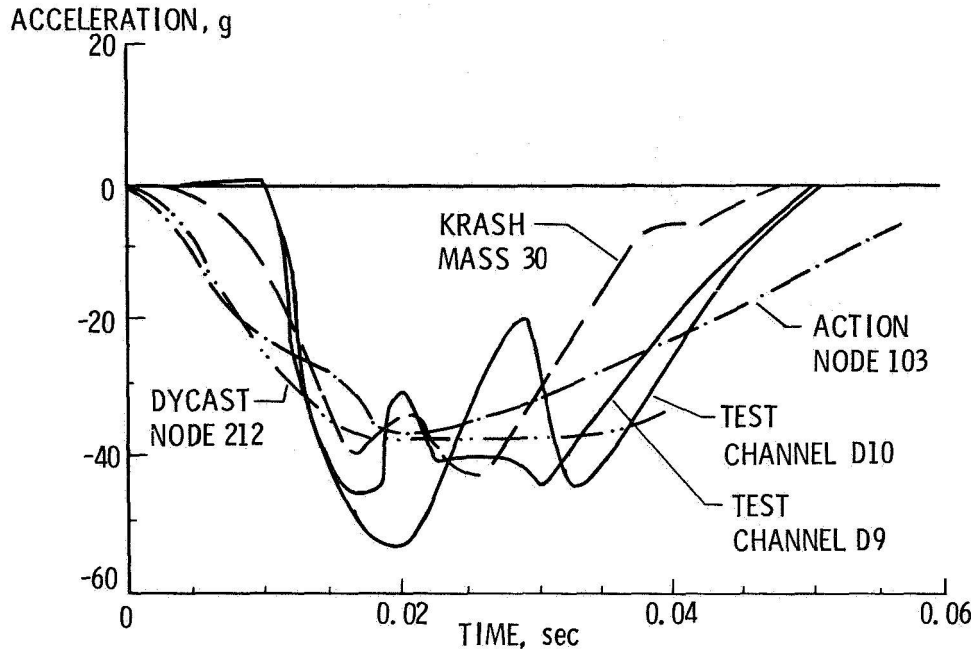

Figure 11.- Comparison of occupant pelvis vertical accelerations from test and analyses.

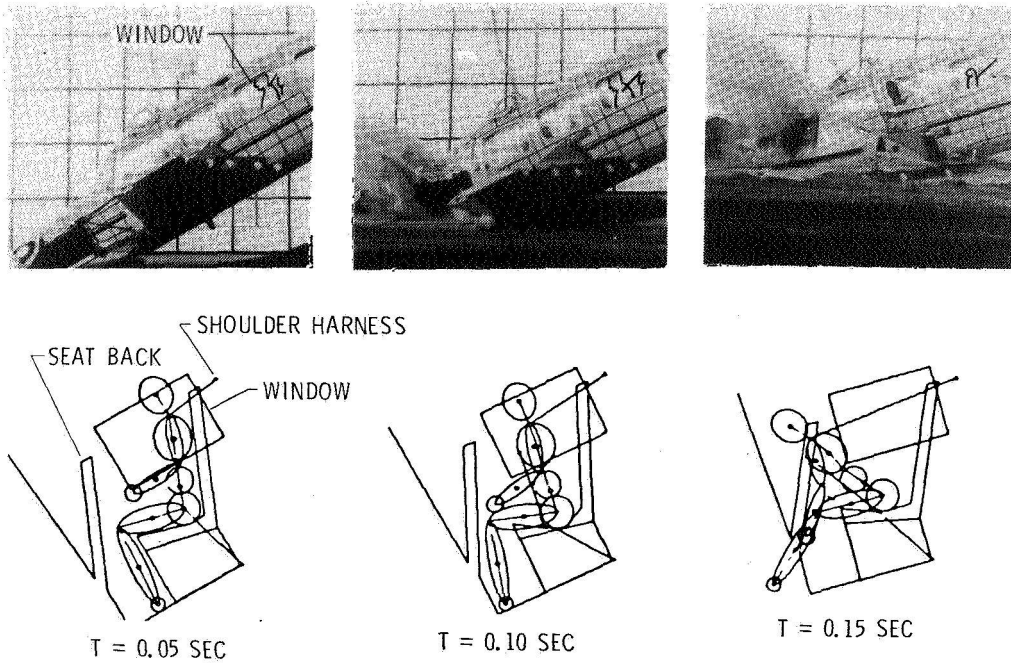

Figure 12.- Two-dimensional computer graphics display of motion of third passenger of -30° , 27 m/s full-scale crash test.

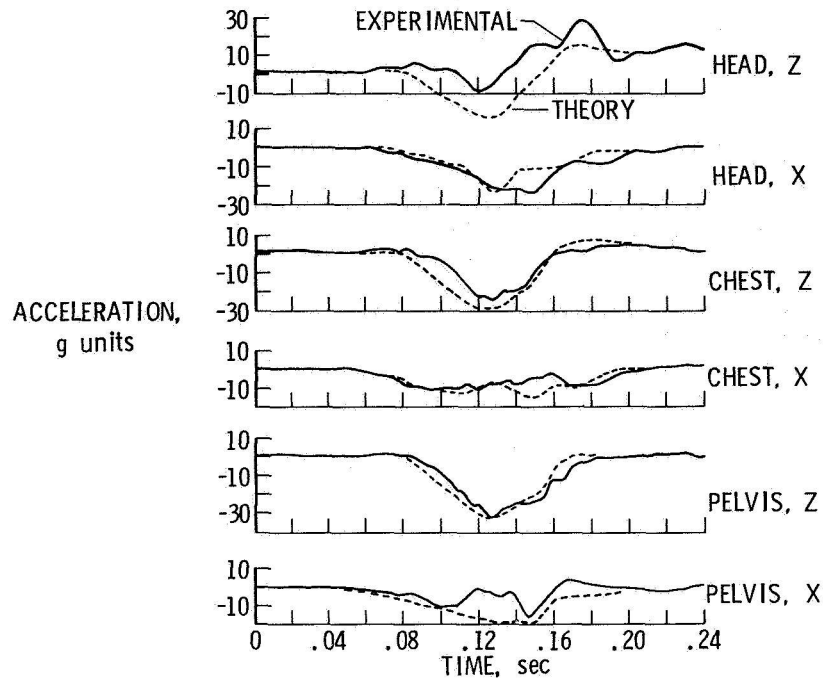

Figure 13.- Experimental and computer dummy accelerations for -30° , 27 m/s full-scale crash test.

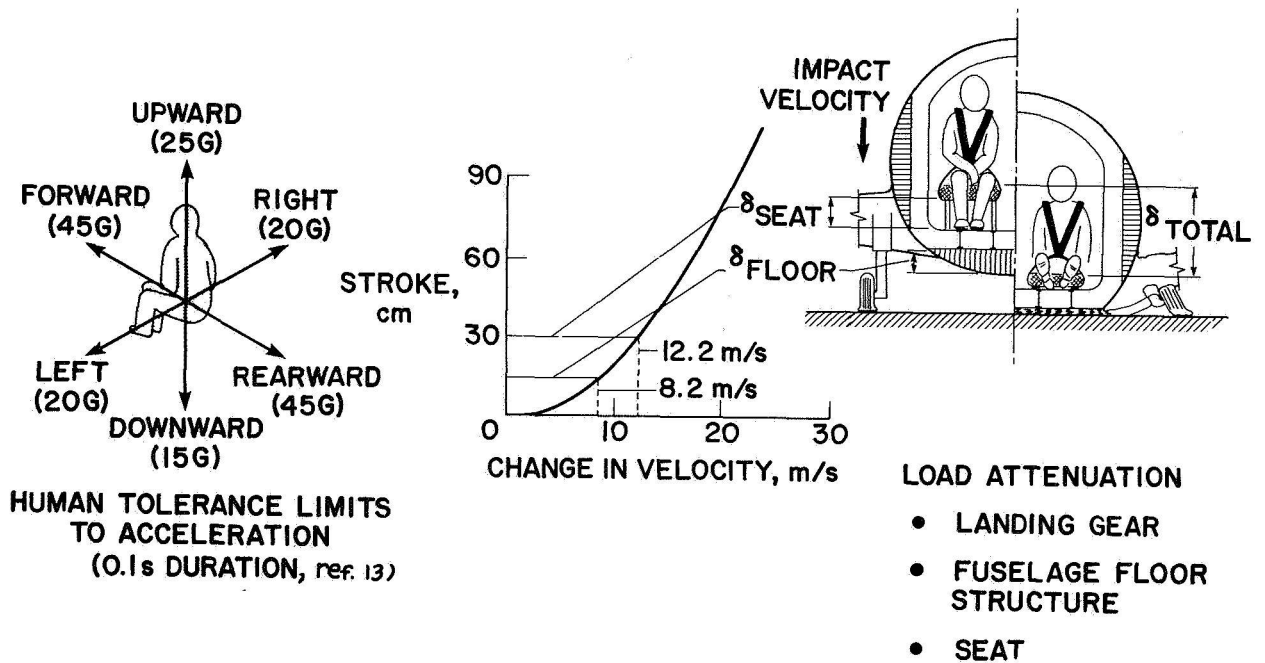
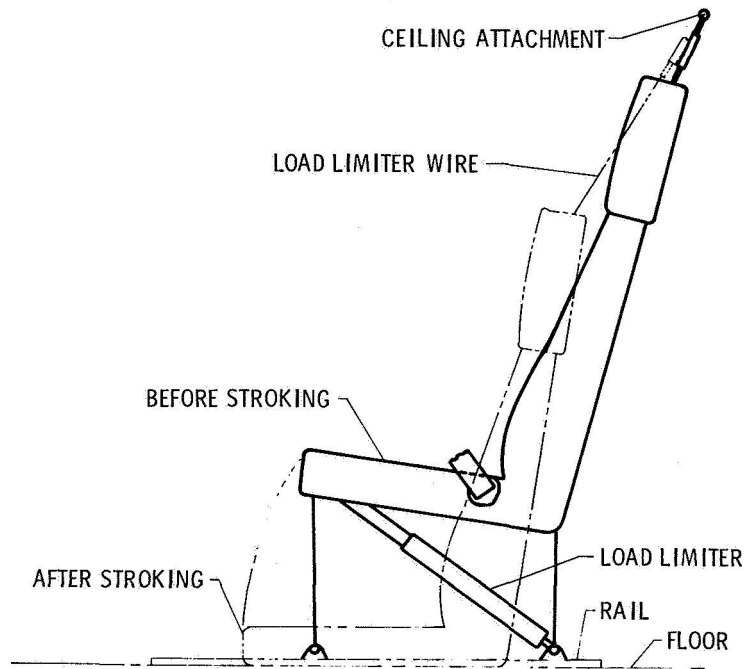

Figure 14.- Available stroke for energy dissipation in typical twin-engine general aviation aircraft.



Figure 15.- Load-limiting seat concepts.



(a) Ceiling-mounted passenger seat.

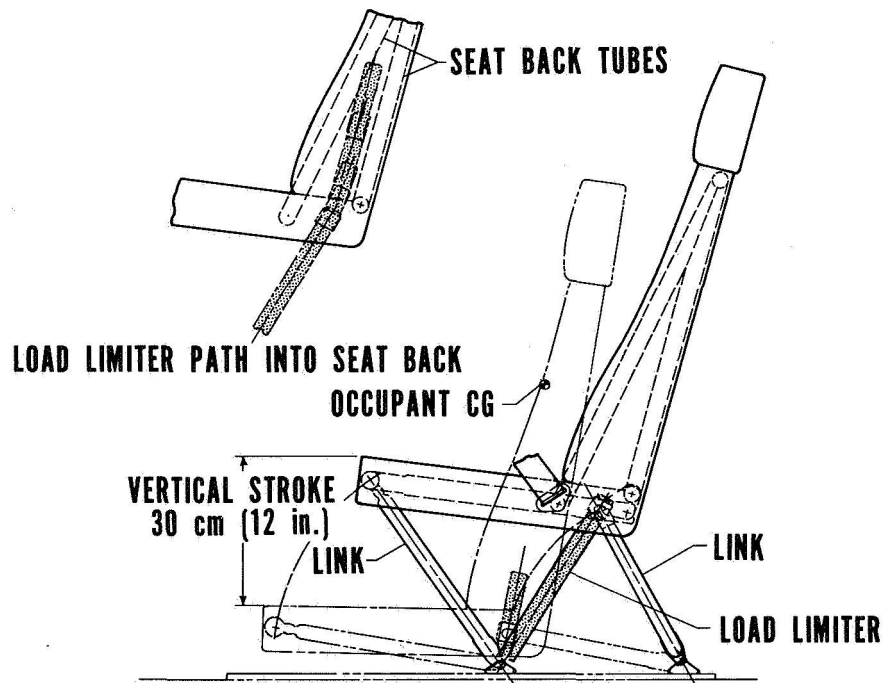

(b) Floor-mounted passenger seat.

Figure 16.- Passenger seats with wire bending load limiters.

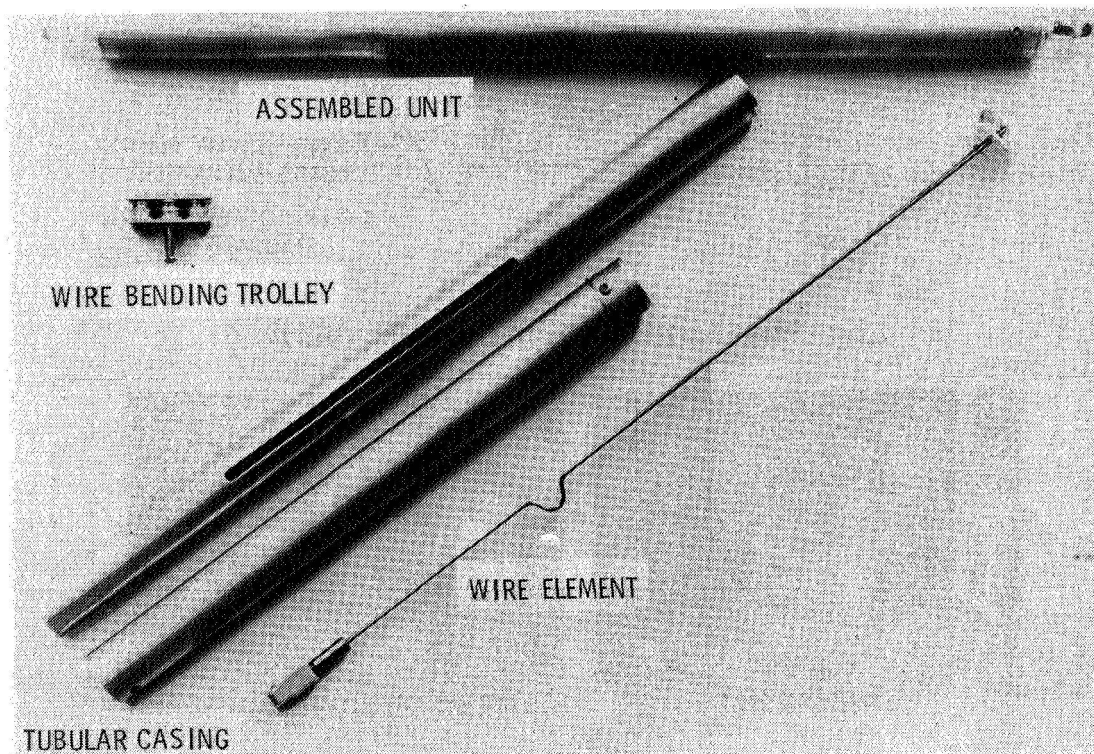
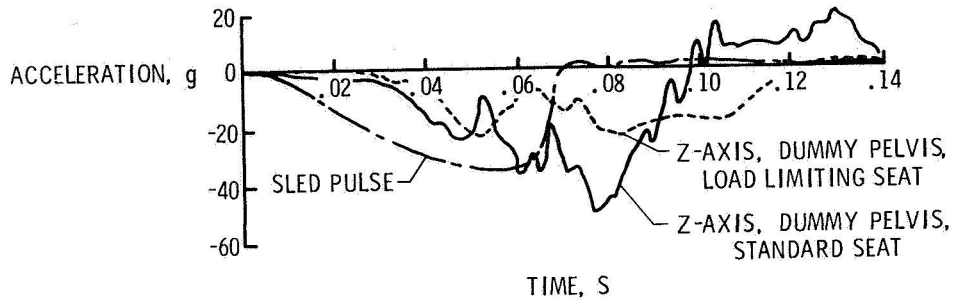
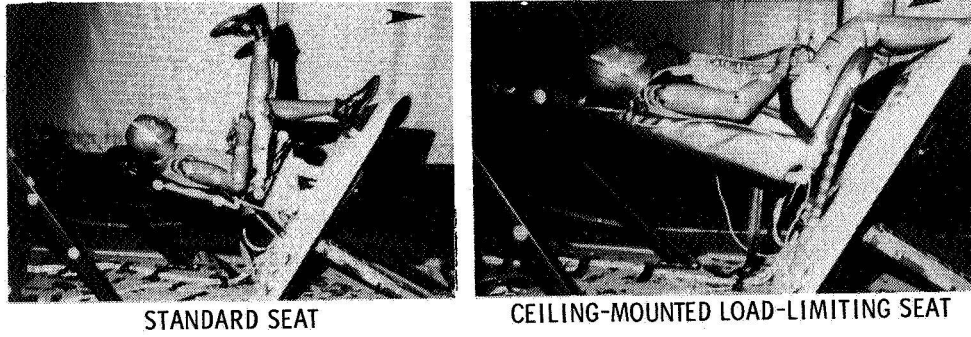
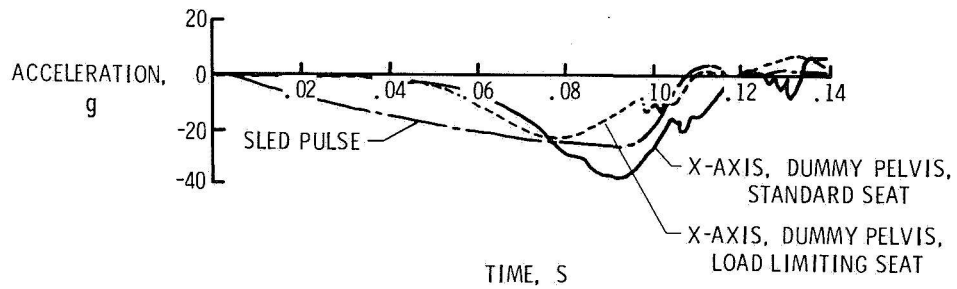
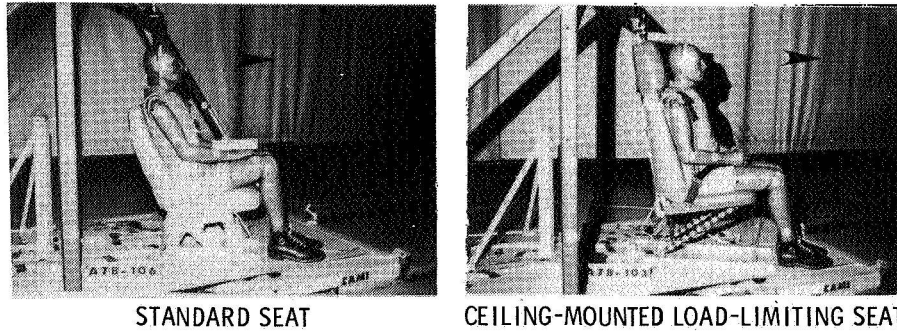

Figure 17.- Wire bending load limiter.



(a) "Vertical" (-30° pitch, 10° roll).



(b) "Longitudinal" (30° yaw).

Figure 18.- Pelvis accelerations for dummy in conventional and ceiling-mounted (load-limiting) seat subjected to "vertical" and "longitudinal" sled pulses.

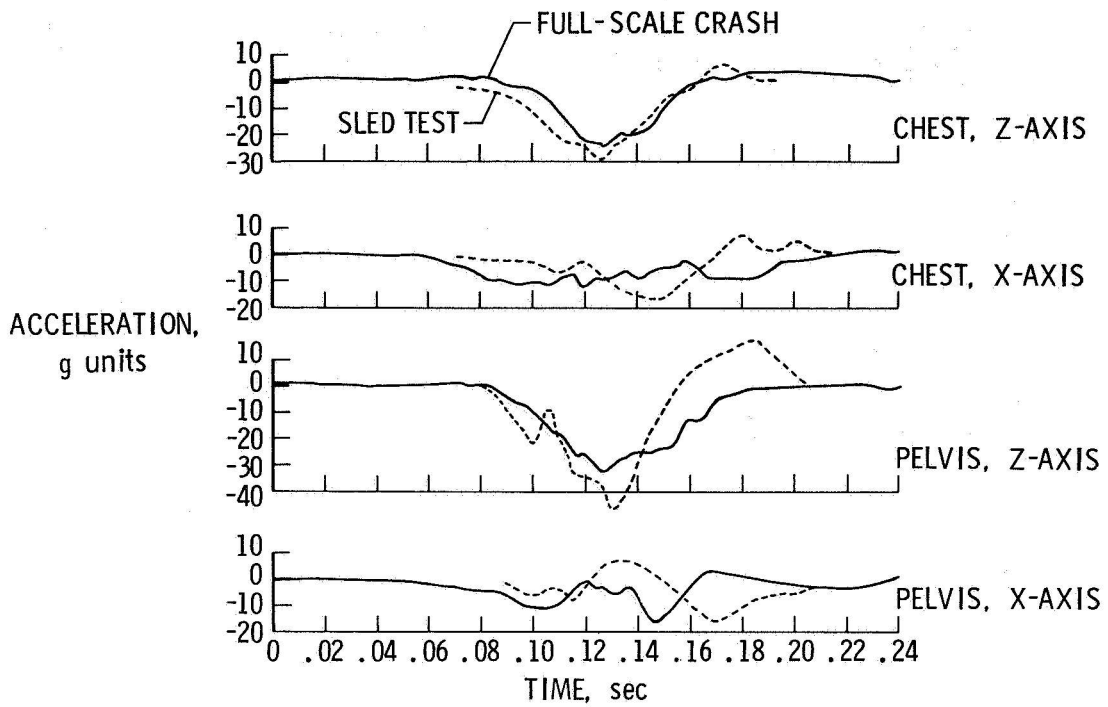

Figure 19.- Dummy accelerations from sled test and from a full-scale test under similar impact conditions.

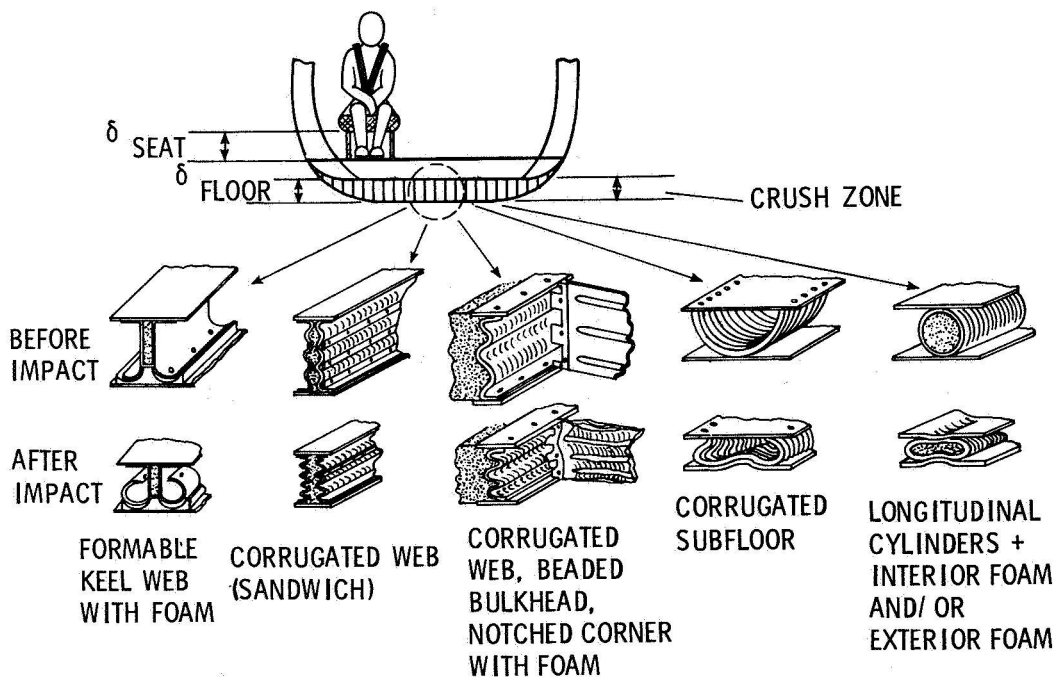

Figure 20.- Load-limiting subfloor concepts.

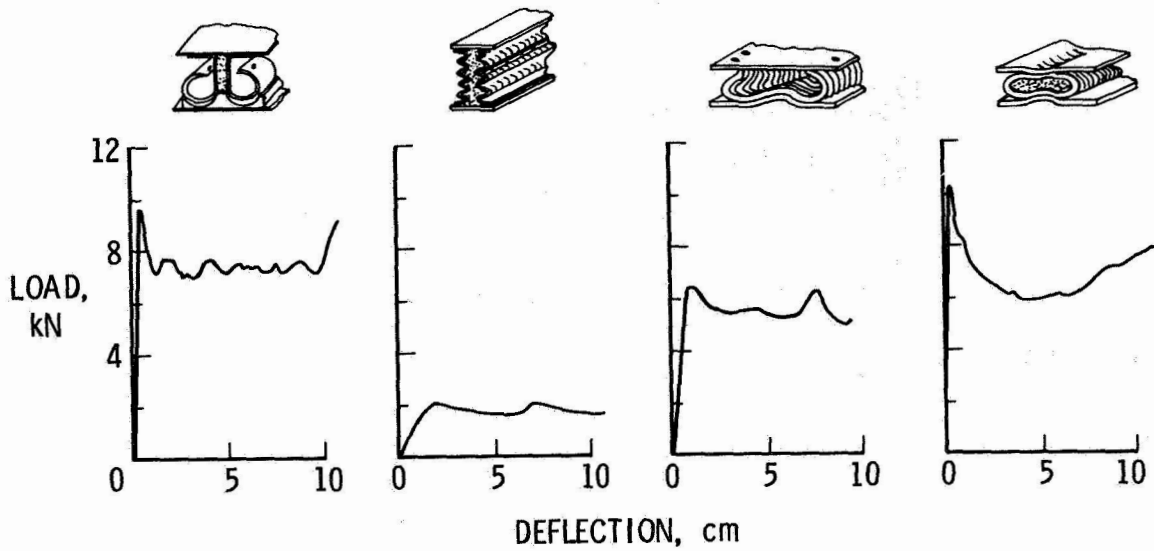

Figure 21.- Load-deflection curves for load-limiting concepts.

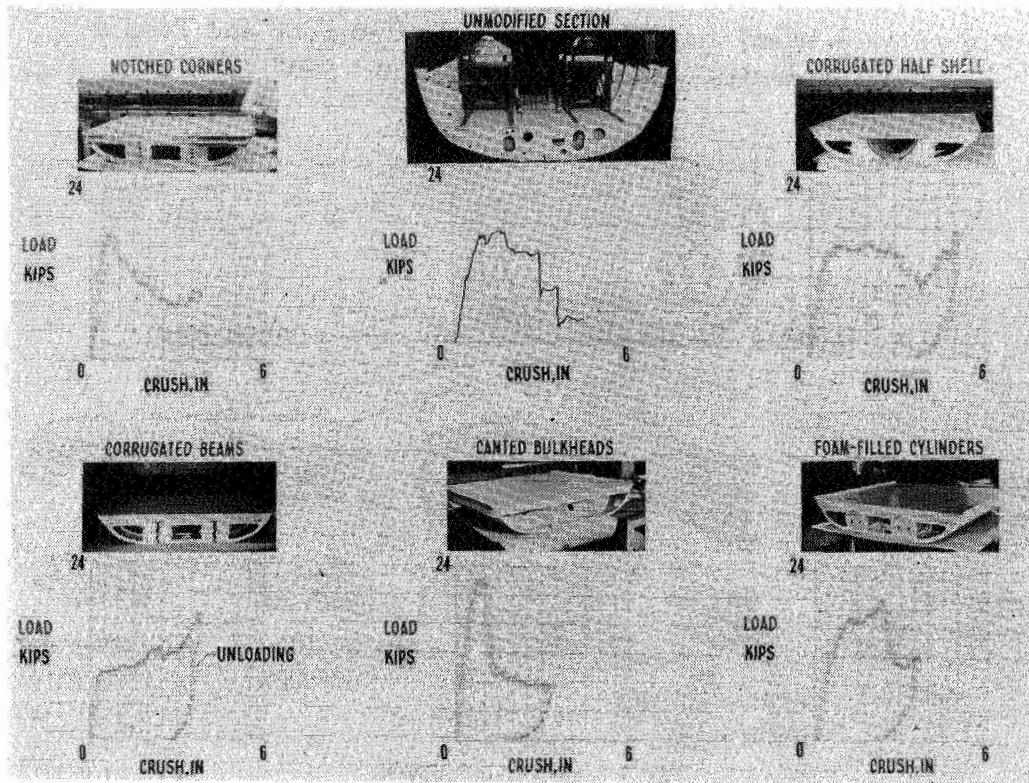

Figure 22.- Load-deflection curves for five load-limiting subfloor sections and an unmodified subfloor section.
(1 kip = 4.5 N; 1 in. = 2.54 cm.)

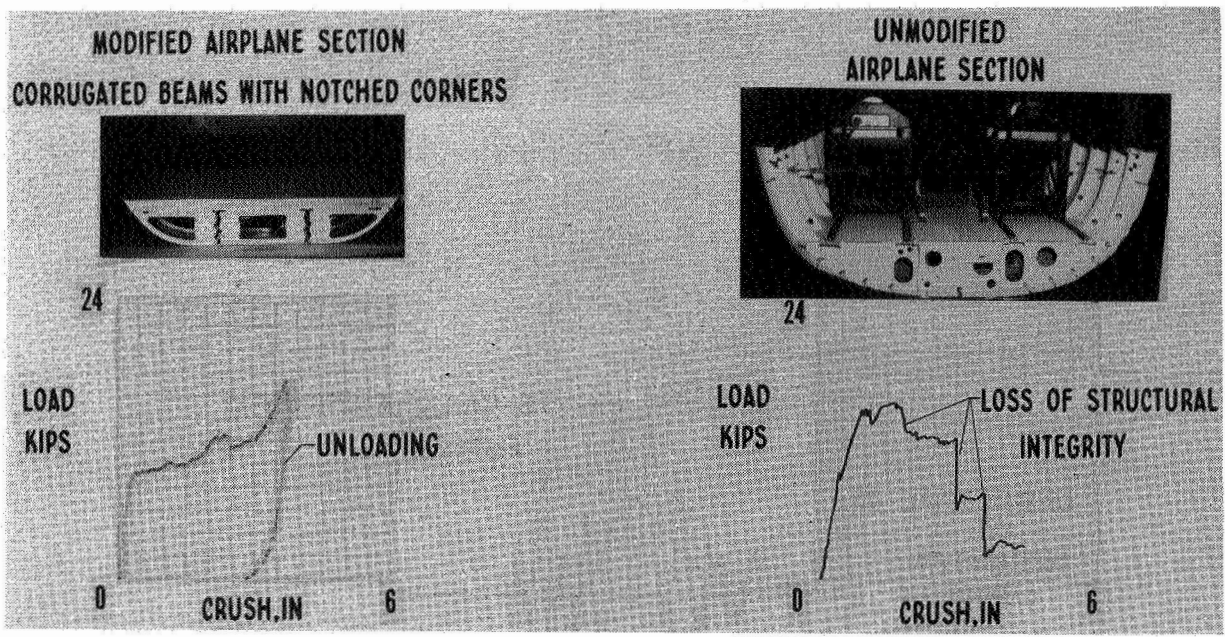

Figure 23.- Comparison of load-deflection curves for corrugated beams with notched corners with unmodified subfloor section. (1 kip = 4.5 N; 1 in. = 2.54 cm.)

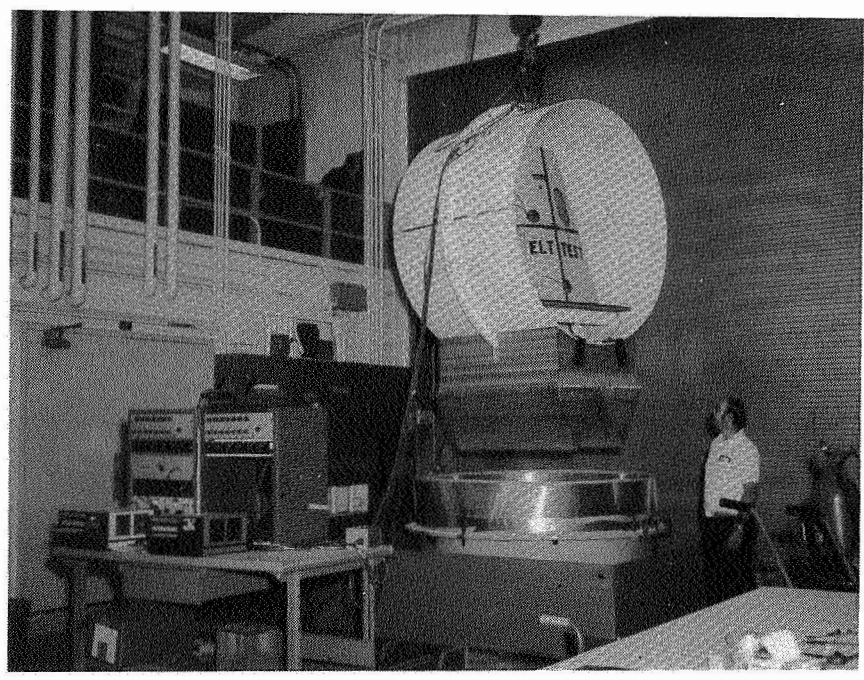

Figure 24.- Emergency Locator Transmitter (ELT) test apparatus.

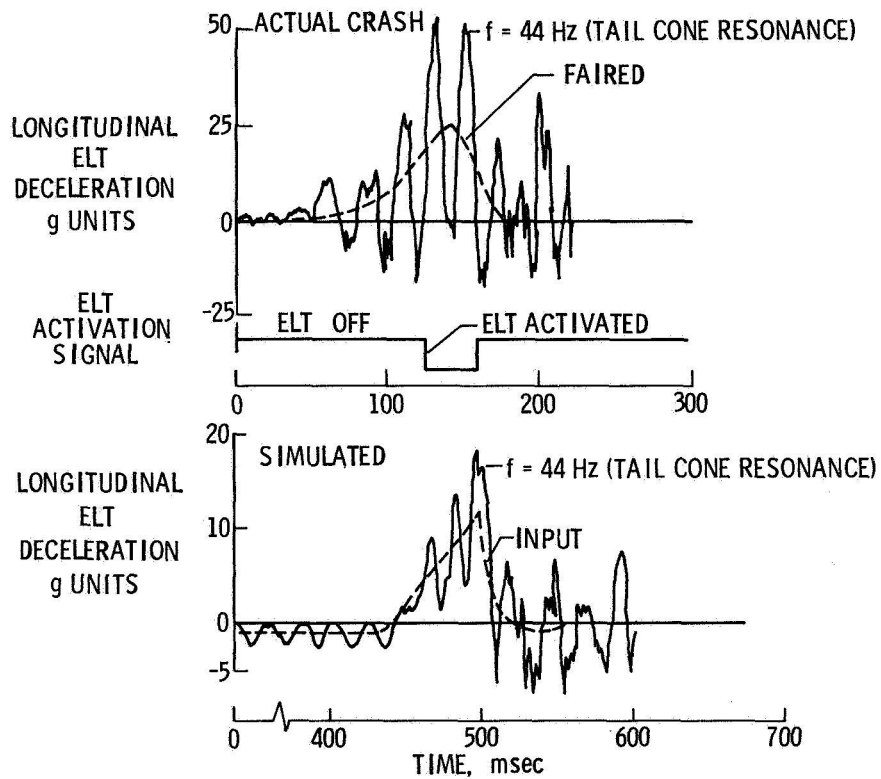

Figure 25.- Actual and simulated longitudinal crash pulses on ELT's.