

**SOLAR ENERGY WATER DESALINATION IN THE
UNITED STATES AND SAUDI ARABIA**

Werner Luft
Project Manager
U.S./Saudi Arabian Program
Solar Energy Research Institute
1617 Cole Boulevard
Golden, Colorado
(303) 231-1233

Jim Williamson
U.S. Program Director
U.S./Saudi Arabian Program
Solar Energy Research Institute
1617 Cole Boulevard
Golden, Colorado
(303) 231-1850

Five solar energy water desalination systems are being designed to deliver 6000 m³/day of desalted water from either seawater or brackish water. After the system definition study is completed in July 1981, two systems will be selected for pilot plant construction. The pilot plants will have capacities in the range of 100 to 400 m³/day.

1.0 BACKGROUND

In October 1977, Saudi Arabia and the United States signed a Project Agreement for Cooperation in the Field of Solar Energy (SOLERAS) under the auspices of the United States-Saudi Arabian Joint Commission on Economic Cooperation. The objectives of the agreement are to:

- cooperate in the field of solar energy technology for the mutual benefit of the two countries, including the development and stimulation of solar industries within the two countries;
- advance the development of solar energy technology in the two countries; and
- facilitate the transfer between the two countries of technology developed under this agreement.

The Solar Energy Research Institute (SERI), as the Operating Agent, is responsible for implementing SOLERAS in accordance with directives of the SOLERAS Executive Board who has approved a five-year technical program plan.

As part of this technical program plan, an area of Industrial Solar Applications for solar technology has been identified. A specific objective is to demonstrate the use of solar energy in desalinating water. Water desalination is needed in both Saudi Arabia and the United States. In Saudi Arabia, water is needed principally for municipal and agricultural applications. In the United States, desalination is mainly required to control river salinity and provide potable water to selected communities that have critical water quality problems or water shortages.

2.0 PROJECT PLANS

To accomplish the objective of the SOLERAS solar energy water desalination project, a 3-phase activity is planned. The phases are as follows:

~~274~~ INTENTIONALLY BLANK

- Phase 1: Preliminary System Design and Cost Analysis
- Phase 2: Detailed Pilot Plant Design and Construction
- Phase 3: Pilot Plant Operation and Training of Personnel

Phase 1: System analyses and economic analyses will be performed by several companies on a solar energy desalination system of their choice for either seawater or brackish water desalination. The systems will each be for an average daily product water capacity of 6000 m³. The main criterion for the analysis will be the product water cost. Each system will be designed for a specific site and application. The site, application, and technology will have broad applicability to general water desalination needs in either the United States or in Saudi Arabia. It is the intent of this project to encourage innovation without unduly affecting performance and reliability. Subsystems and their interfaces will be defined during Phase 1 and product-water cost projections will be made for commercial plants of a range of capacities.

Finally, a development plan for Phase 2 will be generated including detailed cost estimates for the design and construction of a pilot plant with a capacity of 100 to 400 m³/day using the technology of the baseline system.

Phase 2: Of the several systems designed in Phase 1, one system in each category (brackish and seawater desalination) will be chosen for pilot plant construction. The criteria for selection will include levelized cost per unit of product water for the commercial sized plant, design and construction cost for the pilot plant, consistency in cost between the commercial sized plant and the pilot plant, maturity of system design and projected plant reliability. Each pilot plant will have a product-water output capacity of 100 to 400 m³/day. The pilot plants will be designed in detail and constructed on specific sites.

The size of the pilot plant was selected to be within the budget limitations of the SOLERAS Program and is of a capacity that provides useful technical and economic data for planning, design, and construction of a commercially-sized plant. A pilot plant delivering 400 m³/day of desalted water would provide water to 2,000 people or could provide irrigation water for about 8,000 m² of greenhouse agriculture. If the ratio of the ultimate plant capacity to the pilot plant capacity becomes too great, less useful technical and economic information for application to the full scale plant can be extracted from the pilot plant construction and operation.

Phase 3: The pilot plants will be operated and performance measurements made to provide the information essential for designing commercial-sized desalting plants. Local personnel will be trained in the operation and maintenance of the plant so they can make performance measurements.

The schedule for Phase 1 is from October 1980 to July 1981. Phase 2 is expected to start in October 1981 with the pilot plant construction completed by July 1983. Phase 3 will start at the completion of Phase 2 and will continue until the end of 1983.

The five companies that have been awarded contracts for Phase 1 and their team members are shown in Table 1. The technologies involved in the five systems, the water type, and projected plant locations are given in Table 2. The table shows that the five contracts represent six different desalination technologies (seawater and brackish water reverse osmosis are regarded as two different processes), and five different solar energy technologies.

The two companies which utilize point focus thermal collectors are discussed in more detail in the next section.

Table 1. CONTRACTORS FOR PHASE 1

Prime Contractor	Team Members
Boeing Engineering & Construction Co.	Resource Conservation Co. International
Catalytic, Inc.	Science Applications, Inc.
Chicago Bridge & Iron Co.	Foster-Miller Associates, Inc. Arabian Chicago Bridge & Iron Co.
DHR, Inc.	Science Applications, Inc. Ionics, Inc. Al-Radwan
Exxon Research & Engineering Co.	Permutit Co., Inc. Ecodyne-Unitec Div. Martin-Marietta Badger Energy, Inc. Saudi Investment Development Center

Table 2. WATER TYPES, PLANT LOCATIONS, AND TECHNOLOGIES FOR FIVE SYSTEMS

Prime Contractor	Water Type	Plant Location	Desalination Technology	Solar Energy Technology
Boeing	Brackish water	Upton County, Texas, United States	Reverse osmosis, 2 stages in series, 2.4 and 5.9 MPa.	Heliostats and central receiver
Catalytic, Inc.	Brackish water	Brownsville, Texas, United States	Reverse osmosis, 2 stages in series, 2.9 and 5.6 MPa, and vertical tube distillation	Wind generators and line- and point-focus thermal collectors
Chicago Bridge & Iron Co.	Seawater	Al Jubayl, Arabian Gulf, Saudi Arabia	Indirect Freezing	Point-focus thermal collectors
DHR, Inc.	Seawater	Uquair, Arabian Gulf, Saudi Arabia	One stage reverse osmosis in series with electro dialysis	Line-focus thermal collectors and photovoltaics
Exxon	Seawater	Rabigh, Red Sea, Saudi Arabia	Two stages of reverse osmosis in parallel with 24-effect distillation	Heliostats and central receiver

3.0 POINT FOCUS SYSTEMS

The Catalytic solar energy collection subsystem consists of three types of solar thermal collectors, having a total area of 64,000 m². The collectors include high temperature point-focus Omnium-G thermal collectors, medium temperature line-focus Fresnel thermal collectors, and low temperature Winston thermal collectors. In addition, 12 wind generators provide a total of 2.4 MW of electric power.

Energy storage is provided using a high-temperature air thermal storage system over the range of 290°-430°C, and medium temperature and low temperature thermal storage with a range of 45°-120°C and 180°-290°C, respectively. The medium and low temperature thermal storage systems use a liquid medium. The total capacity for the thermal storage system is 60 MWh. The electric storage capacity is 725 kWh.

Energy conversion is obtained through a steam turbine with a 560 kW electric generator and through the use of a power recovery turbine. Backup power is obtained through a motor with a 207 kW electric generator.

The brackish water is pre-treated and uses 18,000 m³ storage tanks. The desalination subsystem consists of two stages of reverse osmosis units in series, operating at 2.9 MPa and 5.6 MPa and operating in series with a multiple effect vertical tube evaporator. The brine is disposed in 93,000 m² surface area evaporation ponds. The water recovery ratio is 0.98.

The Chicago Bridge and Iron system uses 37,000 m² distributed point-focus thermal collectors with two axes tracking. Energy storage is obtained through two tanks containing HITEC molten salt operating over a temperature range from 286°-565°C and having a capacity of 148 MWh.

The energy conversion subsystem uses a steam turbine with a 560 kW electric generator and a turbine driving the 1,216 kW primary refrigeration compressor. Backup power is obtained from a 7.5 MW boiler. There is no waste disposal subsystem as the brine is rejected directly into the sea.

Figures 1 and 2 are block diagrams of the point focus system and show the interaction of the subsystems.

4.0 PROJECT STATUS

Subcontracts for the projects were awarded in October 1980. The efforts to date have focused on the definition of system specifications and trade studies for alternate subsystem configurations and components. Simulation models have also been developed for the plant performance analysis.

The subcontracts for Phase 1 are all firm fixed price. Financial performance is, therefore, the total responsibility of the subcontractors.

The technical performance of the project teams is on schedule. No slippages of major milestones are identifiable at this time. The Phase 1 system studies will be completed in August 1981.

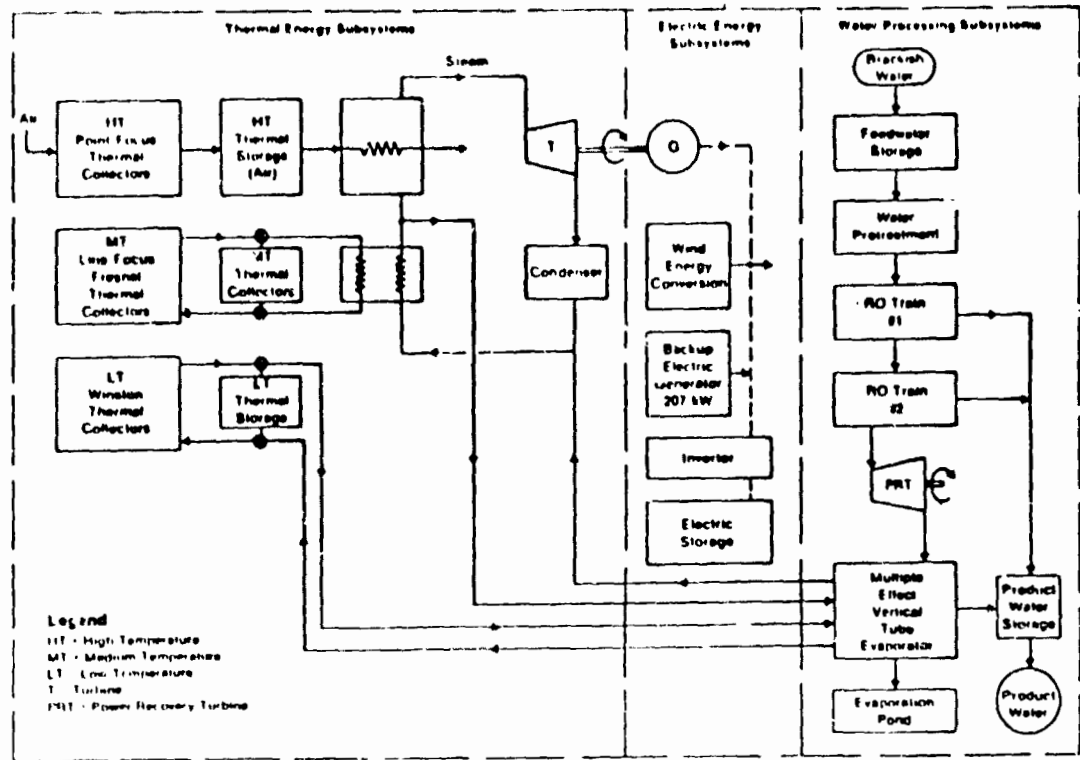

Figure 1 Block Diagram of the Catalytic System

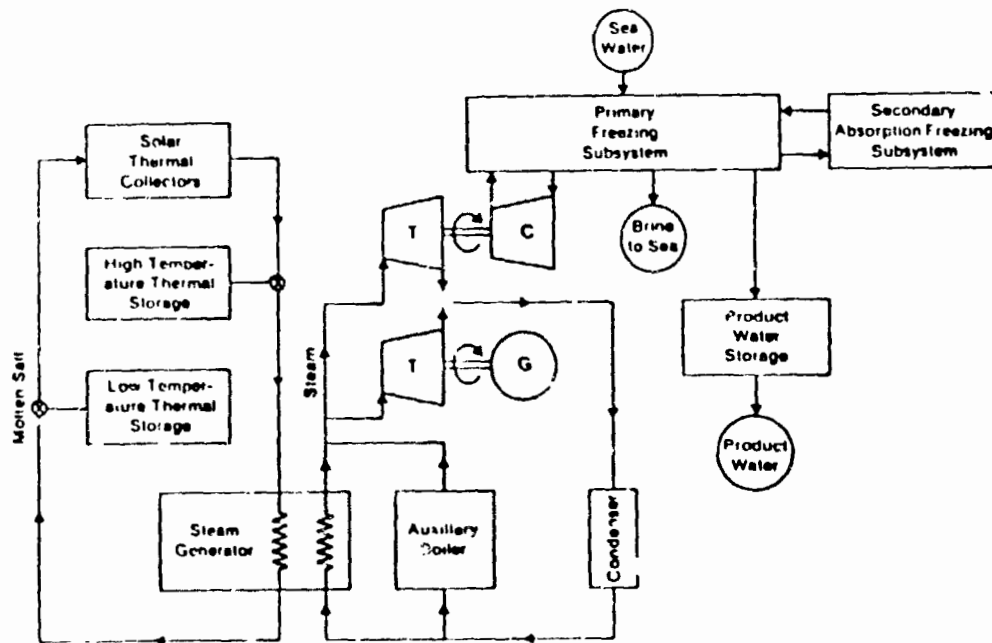
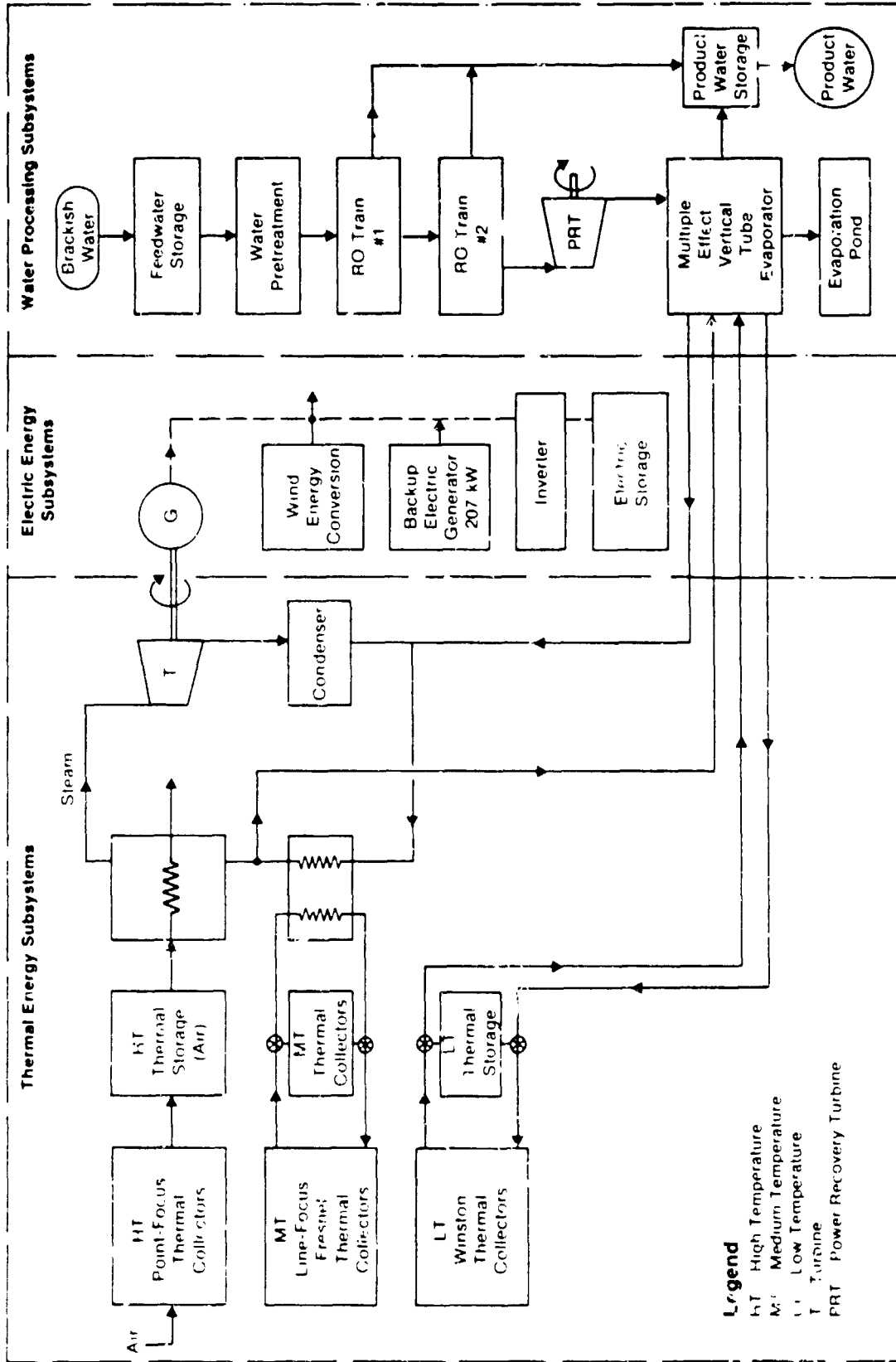
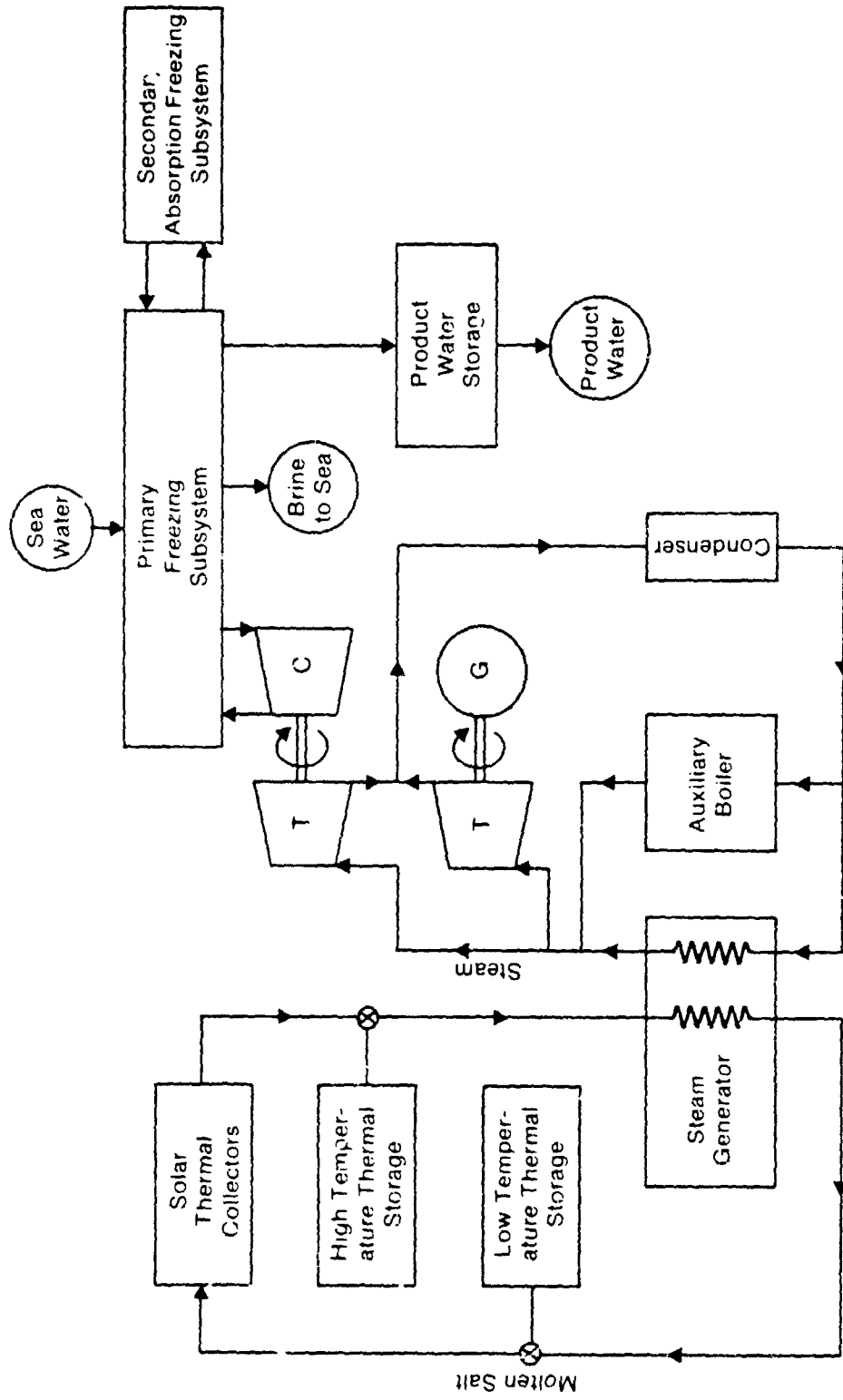

Figure 2 Block Diagram of the Chicago Bridge & Iron System



Catalytic Inc. System



Chicago Bridge & Iron Co. System

10-9