

EXPERIMENTAL RESULTS WITH A SIX-DEGREE-OF-FREEDOM
FORCE-REFLECTING HAND CONTROLLER

A.K. Bejczy and M. Handlykken*)
Jet Propulsion Laboratory
California Institute of Technology
Pasadena, CA 91109

SUMMARY

The six-degree-of-freedom force-reflecting hand controller under current investigation at JPL is an isotonic joystick. Its hand grip is able to follow all the translational and orientational motions an operator's hand can comfortably make within a 30 cm cube. Each degree-of-freedom of this joystick can be backdriven by a motor commanded by the forces and torques sensed at the base of the hand of a remote manipulator. Thus, the operator can "feel" the task he is controlling when this joystick is connected to a remote manipulator through a computer. The use of this joystick for remote manipulator control can generalize the bilateral force-reflecting control of manipulators. Generalization means that the "master arm" function can be performed by this "universal" force-reflecting hand controller which is dissimilar to the "slave arm" both kinematically and dynamically. This paper briefly summarizes and evaluates a few preliminary control experiments performed by using this hand controller connected to a six-degree-of-freedom manipulator equipped with a six-dimensional force-torque sensor at the base of the manipulator end effector. The preliminary control experiments were aimed at the investigation of the human operators' ability to command and control forces in different directions by varying (i) the information conditions and (ii) the values of the feedforward and feedback command gains in the bilateral control loop. The main conclusions are: (i) a quantified graphic display of force-torque information can considerably enhance the operator's ability to perform a quantitatively sharp force-torque control, and (ii) there seems to be a task dependent optimal combination of the feedforward and feedback command gain values which provide a dynamically smooth and stable bilateral control performance.

I. INTRODUCTION

In the current bilateral force-reflecting master-slave manipulator systems widely and successfully employed in the nuclear industry the master and slave arms are in essence identical and interchangeable (Refs. 1-5). A limiting factor for broadening the application of the force-reflecting master-slave manipulator systems is the nature of the master arm. Typically, the present master arms are large and heavy, and require a large operating volume.

A pilot development system has been implemented at JPL recently. The system utilizes a six-degree-of-freedom force-reflecting hand controller as a master arm in combination with a slave arm which is totally dissimilar to the

*) On leave of absence from the Technical University of Norway,
Trondheim, Norway.

hand controller both kinematically and dynamically. The development system is briefly described in Section II. The overall system is a kinesthetically coupled man-machine system. The input-output characteristics of the human hand play a key role in the bilateral control implementation which requires the use of a computer. In Section III control experiments are described aimed at evaluating the human operators' ability to control forces using this general purpose hand controller in a bilateral control mode under varying information and control conditions. The conclusions are summarized in Section IV.

II. EXPERIMENTAL SYSTEM

The main mechanical elements of the development system are shown in Figure 1. They are: a six-degree-of-freedom manipulator, a six-dimensional force-torque sensor mounted to the base of the end effector, and a six-degree-of freedom backdrivable hand controller. A computer which performs the coordinate transformations and closes the control loop between the hand controller and manipulator, as well as the sensor, drive and interface electronics are essential elements of the overall system.

The key mechanical element is the hand controller^{*)} which acts here as a generalized master arm. It is essentially a backdrivable six-dimensional isotonic joystick which has been designed to conform to the motion range of an operator seated at a console. Its hand grip is able to follow all the translational and orientational motions that the operator's hand can comfortably make within a 30 cm (about 1 ft) cube work space. The hand controller mechanism is self-balanced, and can be mounted horizontally (as seen in Figure 1) or vertically. The self-balanced mechanism together with low backlash, low friction and low effective inertia at the hand grip render this hand controller a "transparent" interface between the human operator and a remote manipulator. More on the hand controller mechanism can be found in Reference 6.

The hand controller performs a dual function. First, it provides position and orientation commands to the manipulator. Second, it provides force and torque feedback to the operator's hand from the manipulator. This hand controller does not have any geometric and dynamic similarity to the manipulator it controls. In that sense it is a general purpose device: it can be interfaced to any manipulator through a computer. The computer reads the joint variables measured at both the hand controller and manipulator. Based on these measurements, real time computer algorithms establish the positional and orientational control relations between the hand controller and the manipulator. Likewise, real-time computer algorithms determine the motor torques needed to backdrive the hand controller joints as a function of the forces and torques sensed at the mechanical hand in order to provide a force-torque "feeling" to the operator's hand that parallels the force-torque "feeling" of the mechanical hand. The JPL/CURV manipulator, its kinematics, geometrical equations and control system together with the force-torque sensor integrated with it are described in detail in References 6-8.

*)The mechanism of the hand controller was designed by J.K. Salisbury, Jr., Design Division, Mechanical Engineering Department, Stanford University, Stanford, CA.

Figure 2 shows a simplified linear model of the bilateral control system dynamics referenced to one/one joint of the hand controller and manipulator. For simplicity, the geometric transformations are omitted from Figure 2. The overall performance of the bilateral control system is highly dependent upon the controller's ability of handling the interacting dynamics of the hand controller and manipulator. Note in Figure 2 that these two devices dynamically interact through the operator's hand. Note also in Figure 2 that the force-torque feedback to the operator's hand consists of three parts: (i) velocity damping, (ii) position error feedback, and (iii) feedback from the force-torque sensor. More on the bilateral control system analysis and synthesis can be found in References 9-10.

The simplified linear model shown in Figure 2 is only intended to illustrate two major points: (a) the general frame of the dynamic interaction between the manipulator, hand controller and the operator's hand, and (b) the meaning of the two control parameters, K_g and K_f , which were the key variables in the control experiments described below.

III. EXPERIMENTS

The purpose of the preliminary experiments was (1) to check out the overall performance and stability of the bilateral control system and (2) to evaluate the kinesthetic ability of the operator's hand to control prescribed forces in different directions when (i) the feedforward position scaling K_g and the force feedback gain K_f were changed and (ii) with or without using graphic display of force-torque information.

Four basic control experiments were performed:

1. Push down and hold 50N (~10 lb) force.
2. Push down and glide laterally with 50N (~10 lb) force.
3. Push forward, hold 50N (~10 lb) force, and zero out the lateral and down forces.
4. Push forward and down at the same time, hold 50N (~10 lb) force in each direction and zero out the lateral force.

In experiments 1 and 2 the task was set up so that the operator's wrist was free of lateral tension. In experiments 3 and 4 the task set-up required that the operator's hand be in lateral tension during the force control test. Note that the main force control action was (i) along the line of gravity field in experiments 1 and 2, (ii) perpendicular to the field of gravity in experiment 3, and (iii) with 45 degree tilt relative to the field of gravity in experiment 4. Note also that experiments 3 and 4 required the simultaneous control of all three (F_x , F_y and F_z) force components explicitly. In experiments 1 and 2 only one force component (F_x or F_z) control was required explicitly; the control of the remaining two (F_y , F_z or F_x , F_y) force components was only required implicitly.

Figures 3 through 8 show a few representative samples of the more than 300 experimental data curves generated so far. The unit value of the force feedback gain ($K_f = 1$) was nearly equal to 5N (~1 lb). The unit value of the feedforward gain ($K_s = 1$) signifies a one to one correspondence between the hand controller and manipulator displacements; the value $K_s = 0.5$ means that a 10 cm hand controller displacement causes only a 5 cm manipulator displacement.

The labels V and G at the performance curves in Figures 3 through 8 are related to two different information conditions. For the V curves, the operators had only visual feedback from the task scene together with the manually perceivable force feedback. For the G curves, the operators could observe a real-time color graphic bar display of the F_x , F_y and F_z forces acting on the mechanical hand in addition to the manually perceivable force feedback.

The data to some extent are hardware and software dependent and influenced by training, learning and other external conditions, and the total data base is quite narrow. Therefore, a detailed data evaluation is not yet possible. However, the data obtained so far allow a few general conclusions.

IV. CONCLUSIONS

- 1) Generalization of force-reflecting bilateral control of "master-slave" manipulators is feasible in the sense that the master arm does not have to be a kinematic and dynamic replica of the slave arm.
- 2) There is a trade-off between K_s (position feedforward scaling) and K_f (force feedback gain) parameter values: higher K_s requires lower K_f , or conversely, to obtain a dynamically smooth and stable performance.
- 3) There seems to be an optimal combination of the K_s and K_f parameter values. The optimal combination may be task dependent.
- 4) The operator's body posture, including the posture of his arm and hand holding the hand controller relative to his body, has a major influence on the dynamic performance of the overall control system.
- 5) A quantified graphic display of force-torque information considerably aids the operator in performing a quantitatively sharp force-torque control through a bilateral force-reflecting control system. Under certain gain conditions and without graphic display of force-torque data the system can become unstable (Figure 8).
- 6) The speed and direction at which contact is established between the mechanical hand and object have a major influence on the stability of task performance.
- 7) It is desirable to have a stiffer control coupling between the hand controller and manipulator.
- 8) Higher force feedback capability is desirable in the hand controller.

Acknowledgement

The research described in this paper was carried out at the Jet Propulsion Laboratory, California Institute of Technology, under NASA Contract NAS7-100.

References

1. R. Goertz, Manipulator Systems Development at ANL, Proceedings of the 12th Conference on Remote Systems Technology, ANS, November, 1964, pp. 117-136.
2. L. Galbiati and C. Mancini, A Compact and Flexible Servo System for Master-Slave Electronic Manipulator, Proceedings of the 12th Conference on Remote Systems Technology, ANS, November 1969, p. 73.
3. C.R. Flatau, Compact Servo Master-Slave Manipulator with Optimized Communications, Proceedings of the 17th Conference on Remote Systems Technology, ANS, November, 1969, pp. 154-164.
4. J. Vertut, Experience and Remarks on Manipulator Evaluation, Performance Evaluation of Programmable Robots and Manipulators, NBS Special Publication No. 459, Washington D.C., October 1975, pp. 97-112.
5. D.G. Jelatis, Characteristics and Evaluation of Master-Slave Manipulators, Performance Evaluation of Programmable Robots and Manipulators, NBS Special Publication No. 459, Washington D.C., October 1975, pp. 141-145.
6. A.K. Bejczy and J.K. Salisbury, Jr., Kinesthetic Coupling Between Operator and Remote Manipulator, Proceedings of the International Computer Technology Conference ASME Century 2, Volume 1, San Francisco, CA, August, 1980, pp. 197-211.
7. A.K. Bejczy, Allocation of Control Between Man and Computer in Remote Manipulation, Second Symposium on Theory and Practice of Robots and Manipulators, Proceedings, Eds. A. Morecki and K. Kedzior, Elsevier Scientific Publishing Co., Amsterdam-Oxford-New York, 1977, pp. 417-430.
8. A.K. Bejczy, Manipulation of Large Objects, Third Symposium on Theory and Practice of Robots and Manipulators, Proceedings, Eds. A. Morecki, G. Bianchi and K. Kedzior, Elsevier Scientific Publishing Co., Amsterdam-Oxford-New York, 1980, pp. 301-322.
9. M. Handlykken and T. Turner, Control System Analysis and Synthesis for a Six-Degree-of-Freedom Universal Force-Reflecting Hand Controller, Proceedings of the 19th IEEE Conference on Decision and Control, Albuquerque, NM, December, 1980, pp. 1197-1205.
10. M. Handlykken, Dynamic Stabilization Methods for Bilateral Control of Remote Manipulation, Proceedings of the ISMM Symposium on Mini-and-Micro-Computers in Measurement and Control, San Francisco, CA, May 20-22, 1981.

ORIGINAL PAGE IS
OF POOR QUALITY

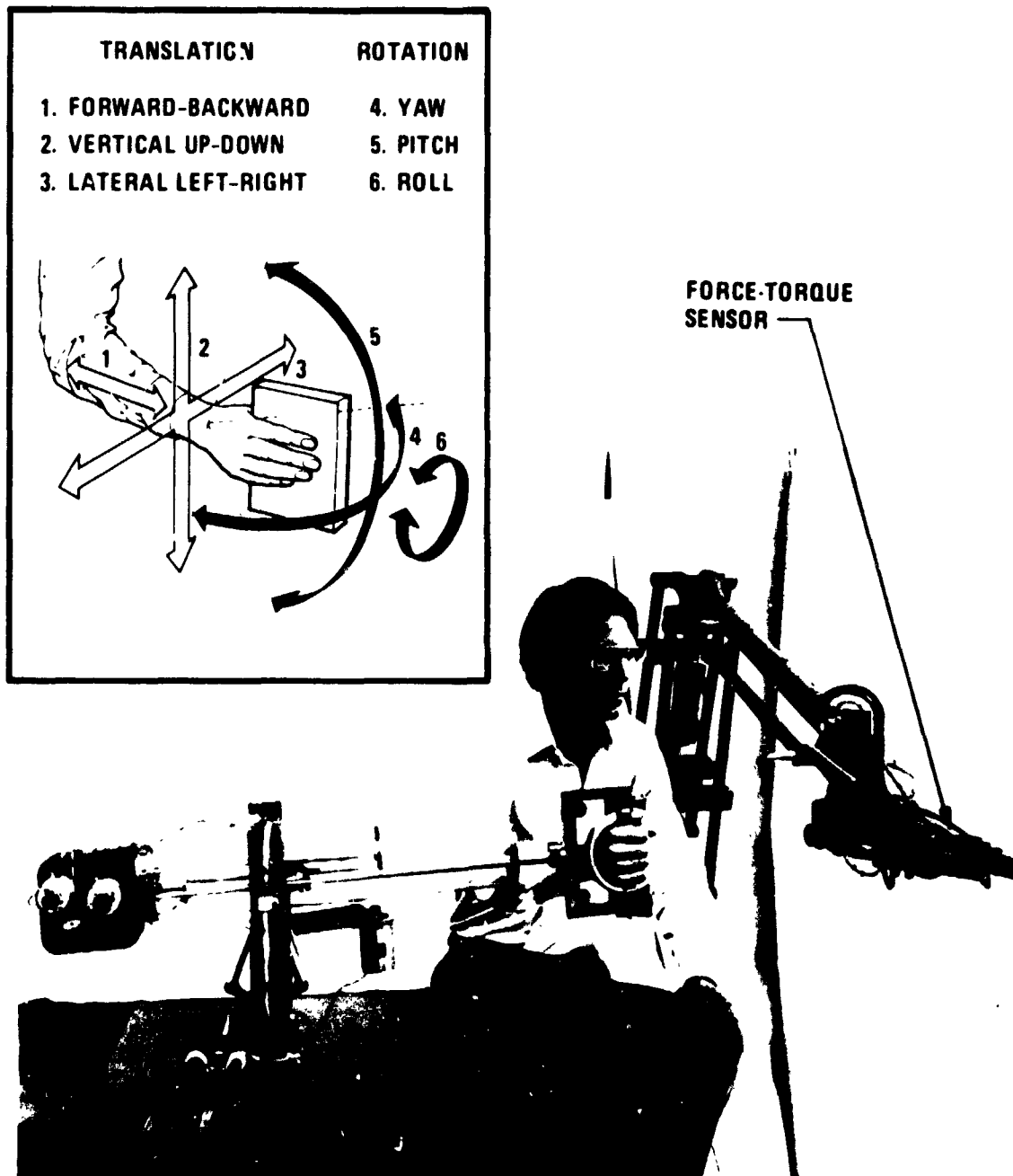
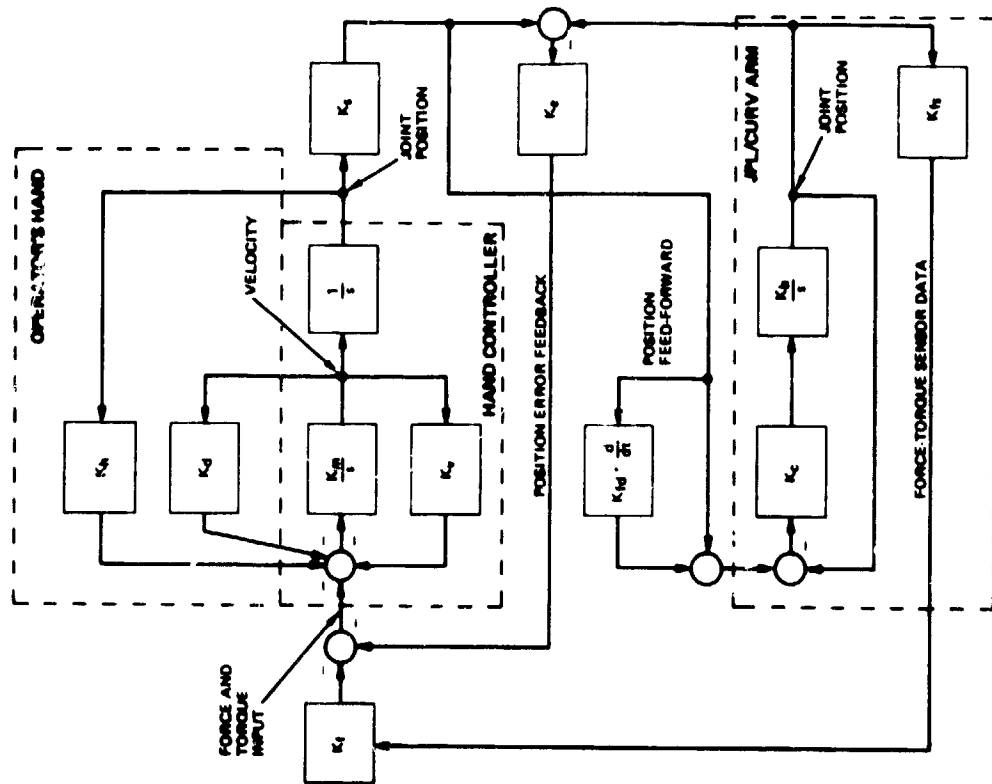
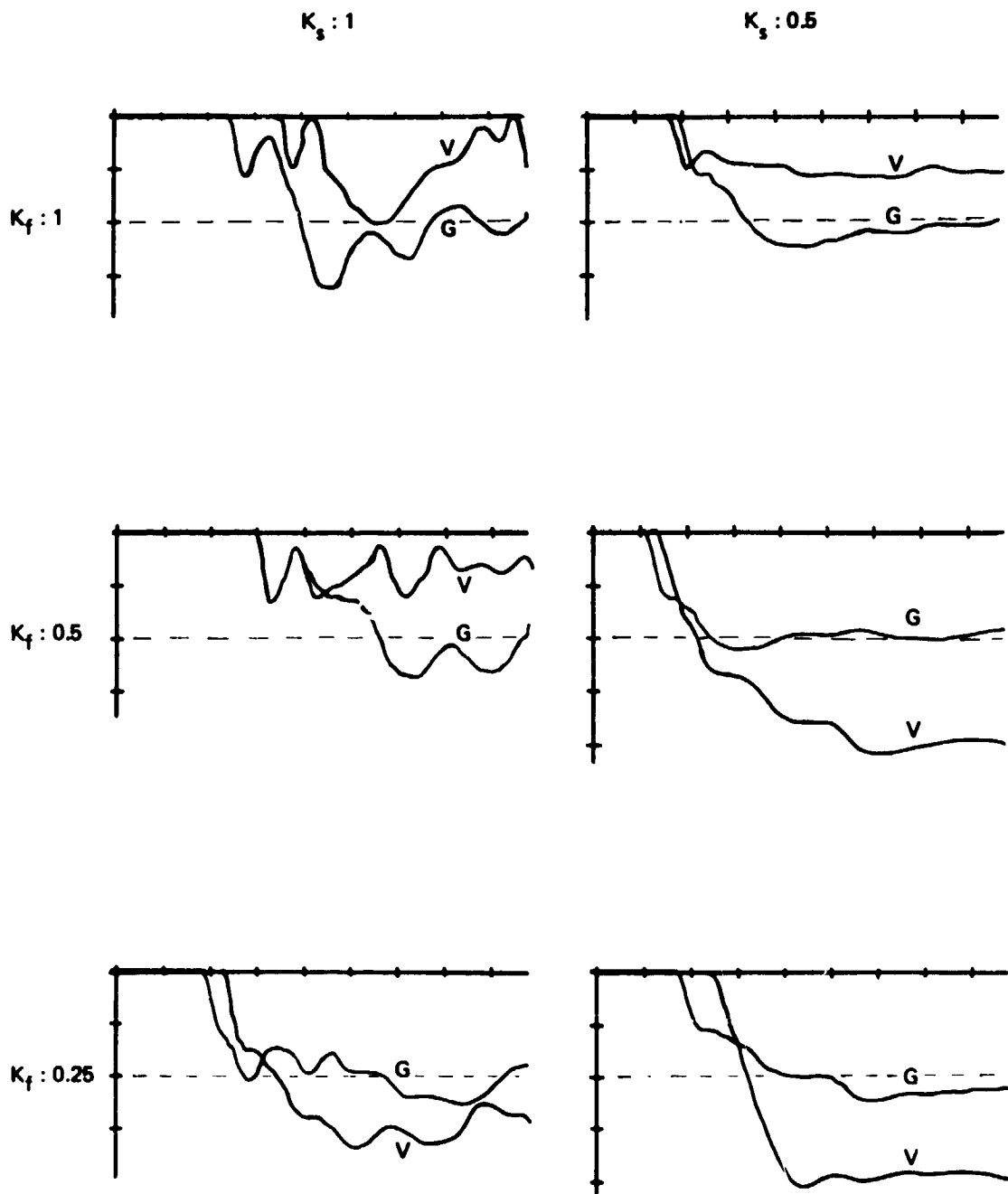

Figure 1. Overall Experimental System and Hand Controller Reference Frame



- K_h : position correction in the operator's hand
- K_d : damping in the operator's hand
- K_m : aggregated hand controller constant formed by the product $K_m = K_t \frac{1}{I_f} K_a$ where K_t is the torque current constant, I_f is the hand controller inertia, and K_a is the DAC/current constant
- K_s : position feed-forward scaling
- K_f : force feedback from force-torque sensor
- K_v : velocity damping
- K_e : position error feedback (to synchronize hand controller and manipulator motion)
- K_{fd} : position feed-forward to manipulator controller
- K_c : manipulator controller gain (hardware implemented)
- K_b : manipulator rate voltage constant (includes hydraulic system and amplifier)
- K_{fs} : position/force constant (includes elasticity of both manipulator and object being contacted by end effector); it is zero when the end effector is not "forcing" any object.

Figure 2. Simplified Bilateral Control Dynamics



VERTICAL AXES: FORCE, 25 N PER MARK.
 HORIZONTAL AXES: TIME, 1 SEC PER MARK

K_s : POSITION FORWARD GAIN

K_f : FORCE FEEDBACK GAIN

V : ONLY VISUAL SCENE OBSERVATION

G : ALSO GRAPHIC DISPLAY OF FORCE DATA

Figure 3. Push Down and Hold Experiments Data

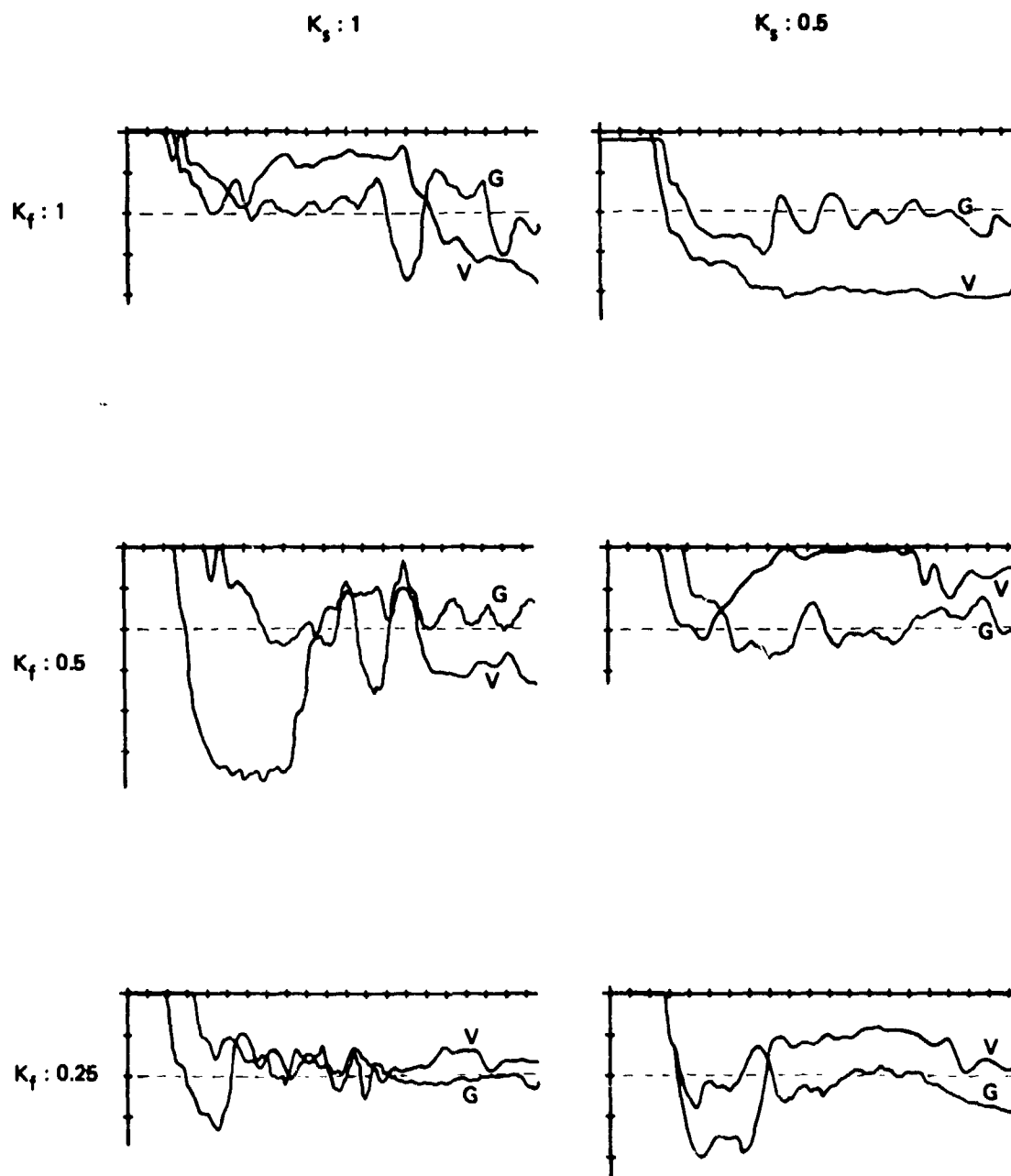

VERTICAL AXES: FORCE, 25 N PER MARK
 HORIZONTAL AXES: TIME, 1 SEC PER MARK

K_s : POSITION FORWARD GAIN
 K_f : FORCE FEEDBACK GAIN
 V : ONLY VISUAL SCENE OBSERVATION
 G : ALSO GRAPHIC DISPLAY OF FORCE DATA

Figure 4. Push Down and Lateral Glide Experiments Data

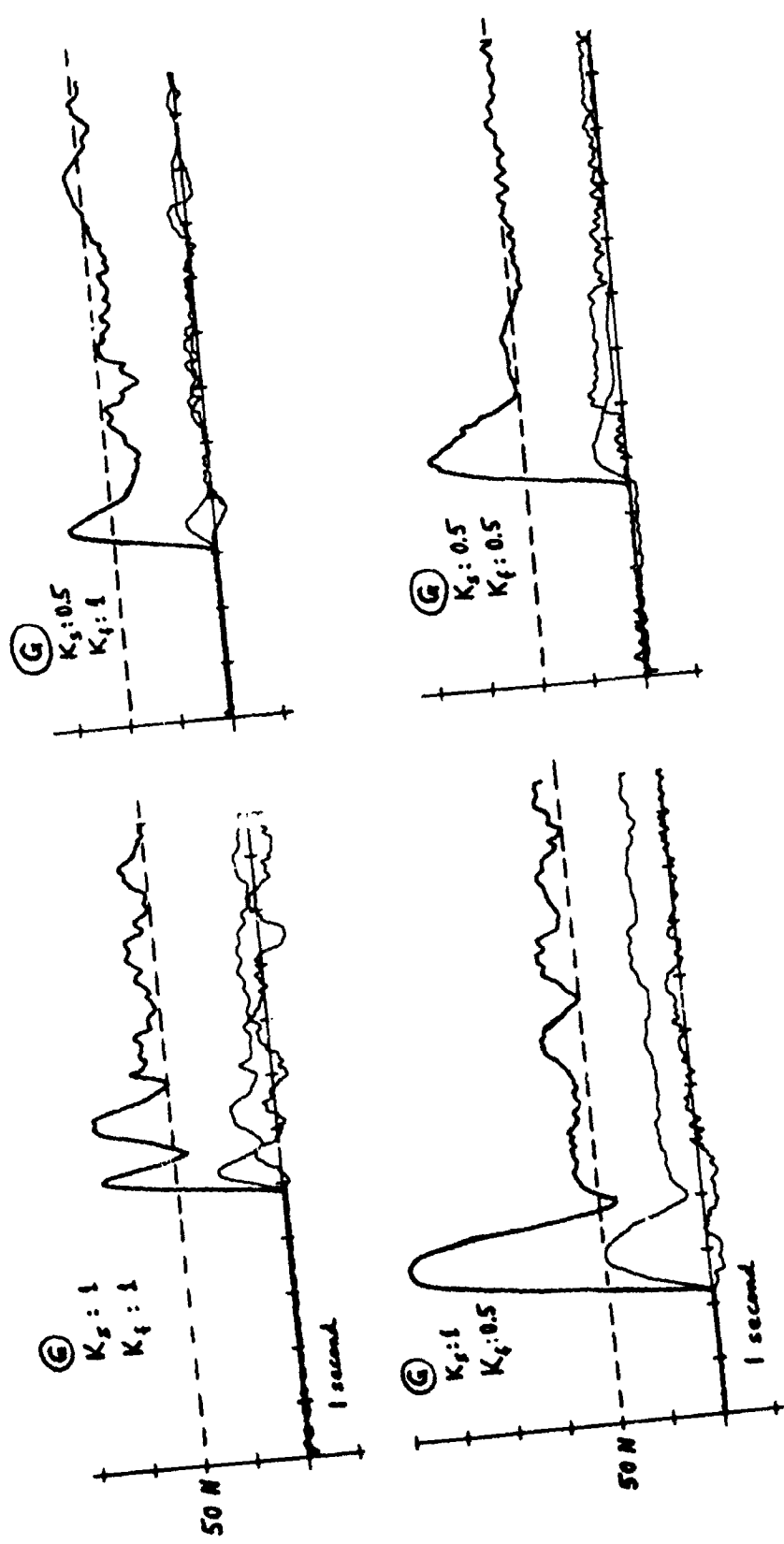

Figure 5. Push Forward, Hold Forward Force, and Zero Out Lateral and Down Forces, Using Also Graphic Display of Force Information

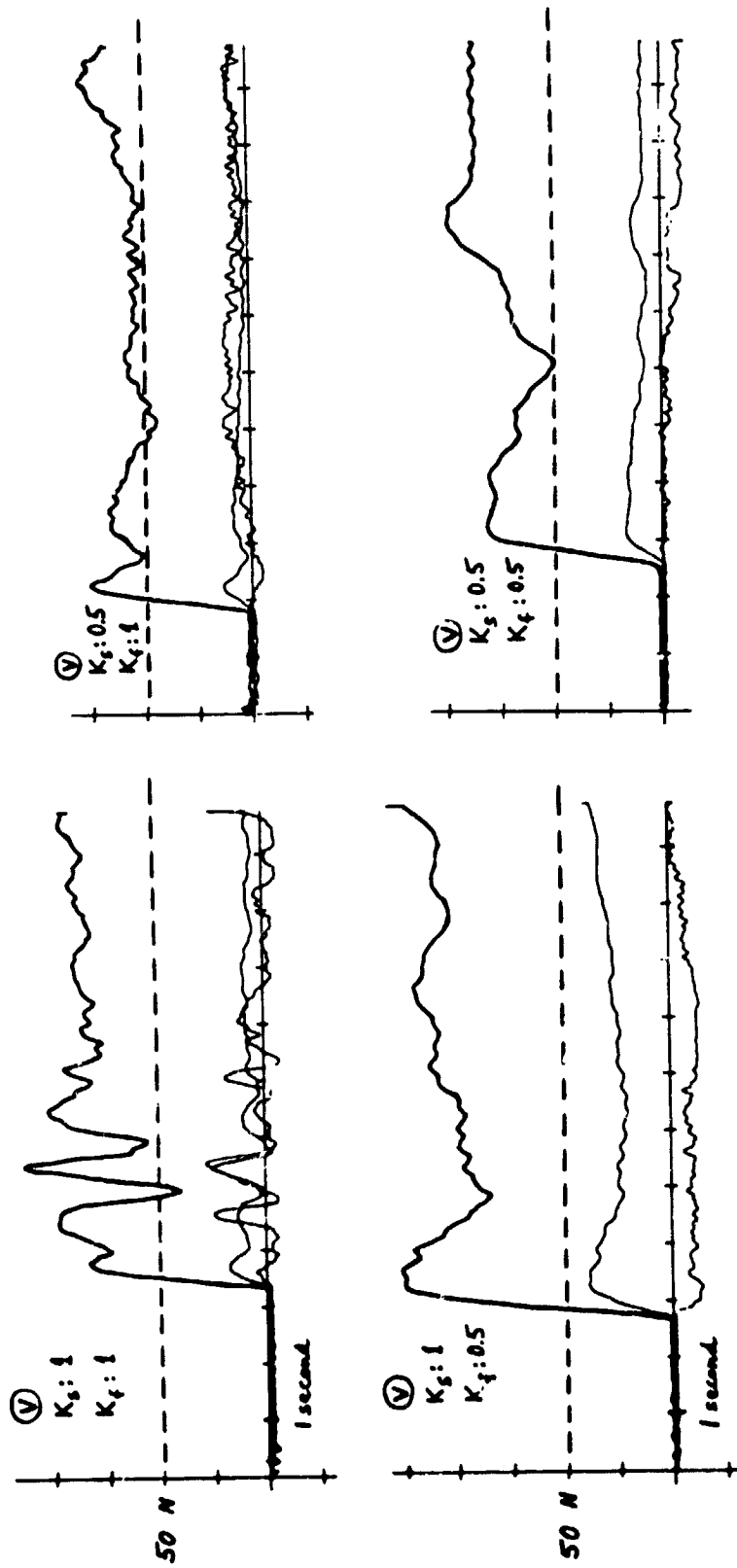

Figure 6. Push Forward, Hold Forward Force, and Zero Out Lateral and Down Forces, Without Graphic Display of Forces

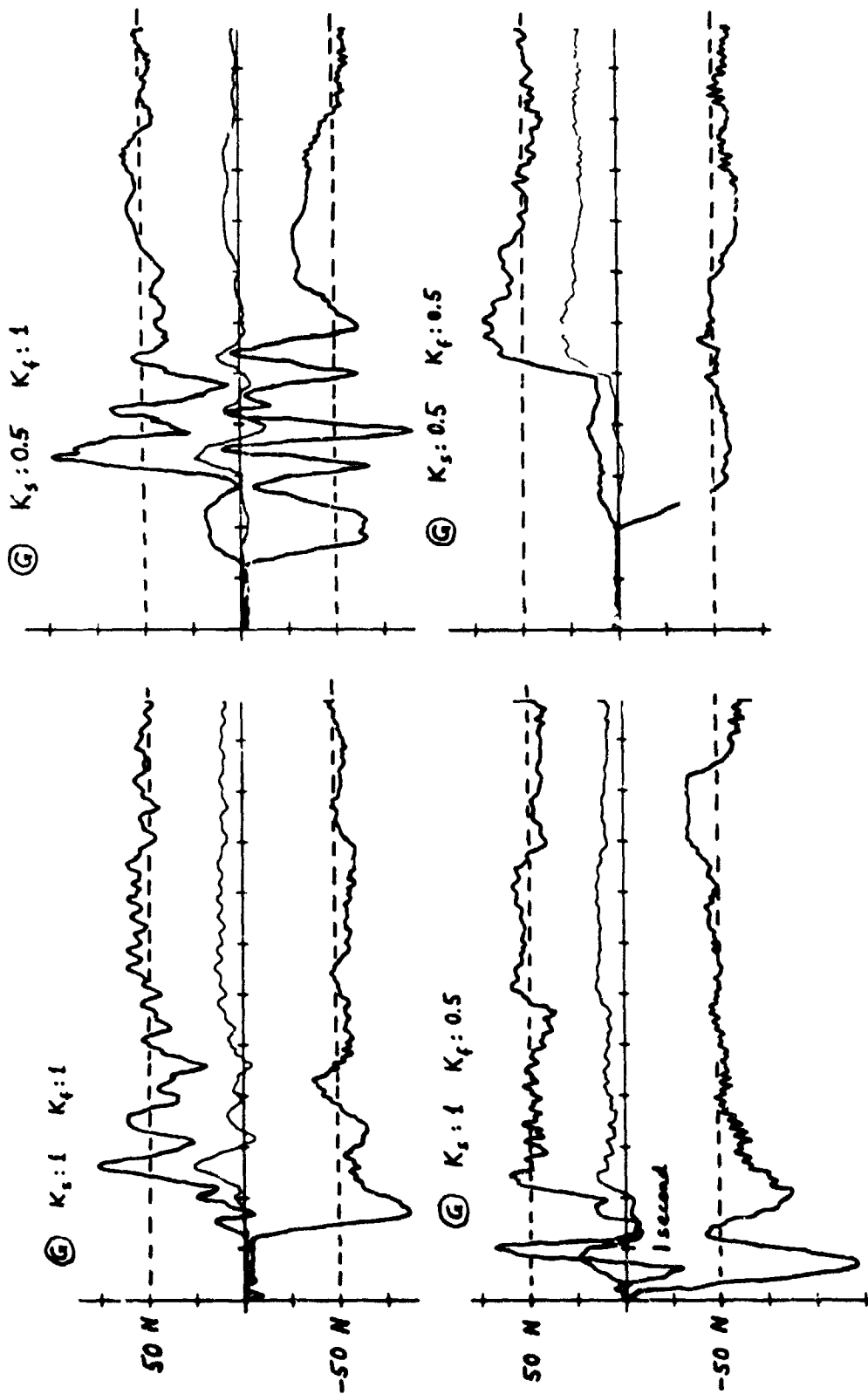

Figure 7. Push Forward and Down Simultaneously, Hold Force in Each Direction, and Zero Out Lateral Force, Using Also Graphic Display of Force Information

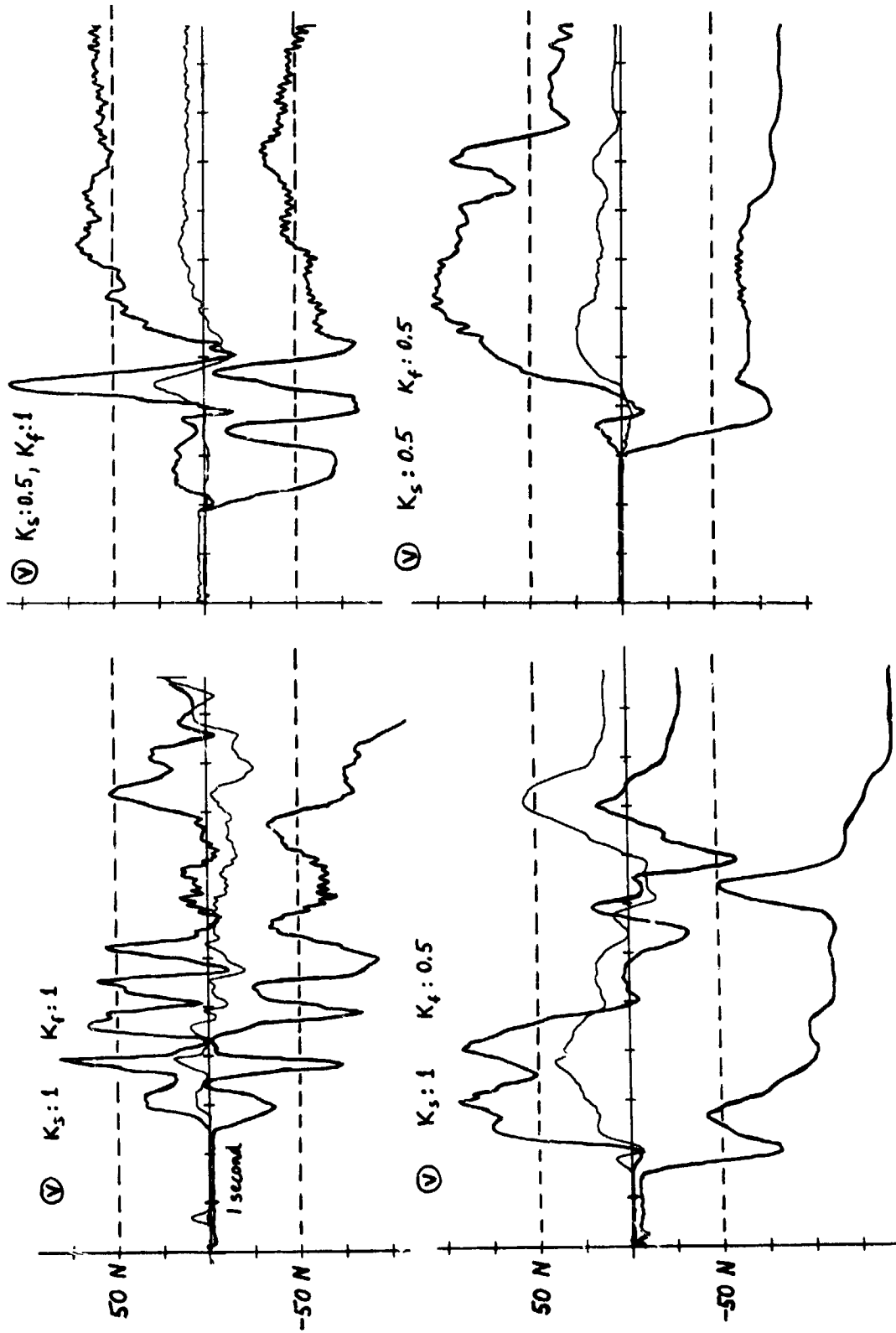

Figure 8. Push Forward and Down Simultaneously, Hold Force in Each Direction, and Zero Out Lateral Force, Without Graphic Display of Forces