

PUPILLOMETRY, A BIOENGINEERING OVERVIEW

G. Myers, J. Anchetta, B. Hannaford, P. Peng, K. Sherman, L. Stark, F. Sun, S. Usui, UCB, Berkeley, CA.

INTRODUCTION

We have chosen to study the pupillary control system for two classes of reasons: First there are reasons of convenience. The pupil is exposed to view and is relatively easily measured. Most of its inputs (light, accommodation, and vergence) are easily controlled.

The second class of advantages is essentially analytic. The inputs are relatively well understood. Light and accommodation/vergence level form the most important inputs to the system. One can study its open loop response to light using a very simple technique—Maxwellian view (Figure 1). Inputs from cortical structures, while present, are less significant in the pupil system than in other biocontrol systems. Thus the pupil functions very nearly as a true reflex. The basic functions of the pupil are to: 1. Control the amount of light on the retina, and 2. Assist the accommodative system by changing the depth of field as required. The pupil has only one degree of freedom, its size (area or diameter), thus simplifying the state equations.

The above factors mean that the pupil system may be studied without altering its structure. We believe that it is imperative to study the behaviour of a complex system in an intact state. Our studies are conducted on cooperative human subjects.

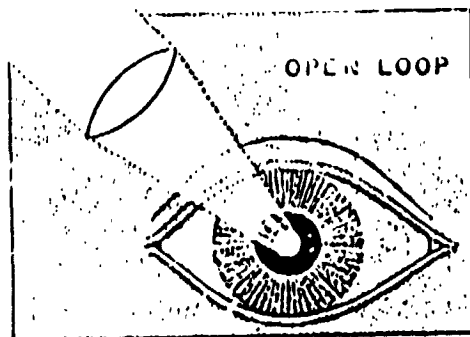

Figure 1. In Maxwellian view, light is focused at the plane of the pupil and passes through the center. Changes in pupil size do not change the amount of light on the retina, thus the pupil control system is open loop.

## INSTRUMENTATION A HISTORY OF THE PUPILLOMETER

The pupil has been studied since 1619. But in that early period the method was direct observation for clinical purposes. In 1927, Lowenstein (Ref 1) used ultra-violet movies and in 1942 used infrared movies (Fig 2). He made motion pictures of the eye and measured the size of the pupil by hand. He obtained accurate data and plotted pupil response curves. But this method required much time and a large amount of infrared film. His interest was also primarily clinical.

The first dynamic real time pupillometer (infrared photo electronic method, see Fig. 3) was built by Stark in 1957 (2). Using infrared light illuminating the eye surface, the total amount of reflected light depends upon the pupil size. The amount of light can be measured by a photocell. After amplification, the signal of pupil size was recorded immediately on a chart recorder, and a camera was used for calibration. Using this method Stark measured the transfer function of the pupillary system and set up a third order differential equation which is the first mathematical model of the pupil.

Lowenstein used infrared light passing through a rotating drum, scanning the eye surface, to obtain pupil diameter. Because mechanical scanning is slow, its bandwidth is very limited.

The TV pupillometer was first used by Stark in 1961 to measure the pupil diameter. And now a new computer TV pupillometer measuring the area of pupil has been developed in our lab.

## SYSTEM DESCRIPTION

### HARDWARE

Figure 4 is a block diagram of the Microprocessor Based Integrative Pupillometer. The eye is illuminated by an infrared source, the image of the eye is captured by a closed circuit TV camera. The video signal is DC restored, and thresholded at a level set by the operator. Generally, the pupil is the darkest object in the image, and no additional processing is required. If dark areas due to eyelashes, eyelids, limbus, etc appear in the thresholded image, they may be excluded by spatial windows, which are also controlled by the operator. The video scans the eye, refreshing the image 60 times/sec. As the video scans the pupil image, a digital counter is enabled. The counter is incremented by a free running clock (18MHz). At the end of a frame, the computer program reads the contents of the counter, and resets the

ORIGINAL PAGE IS  
OF POOR QUALITY.

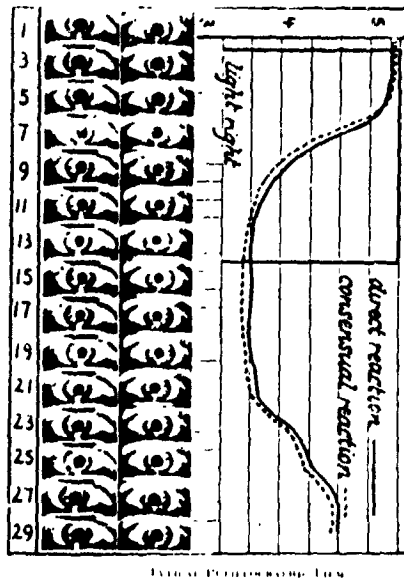
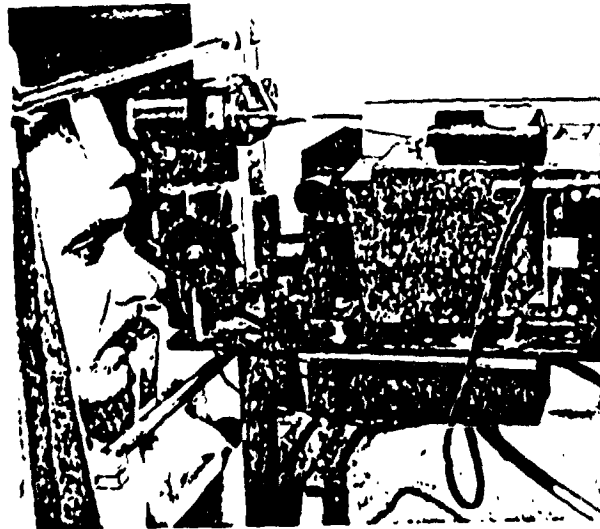

FIG. 2 PHOTOGRAPHIC FILM PUPILLOMETER (1962, O. Lowenstein)



Physical arrangement of pupillometer, subject and telescope

FIG. 3 DYNAMIC PHOTOELECTRONIC PUPILLOMETER (1957, L. Stark)

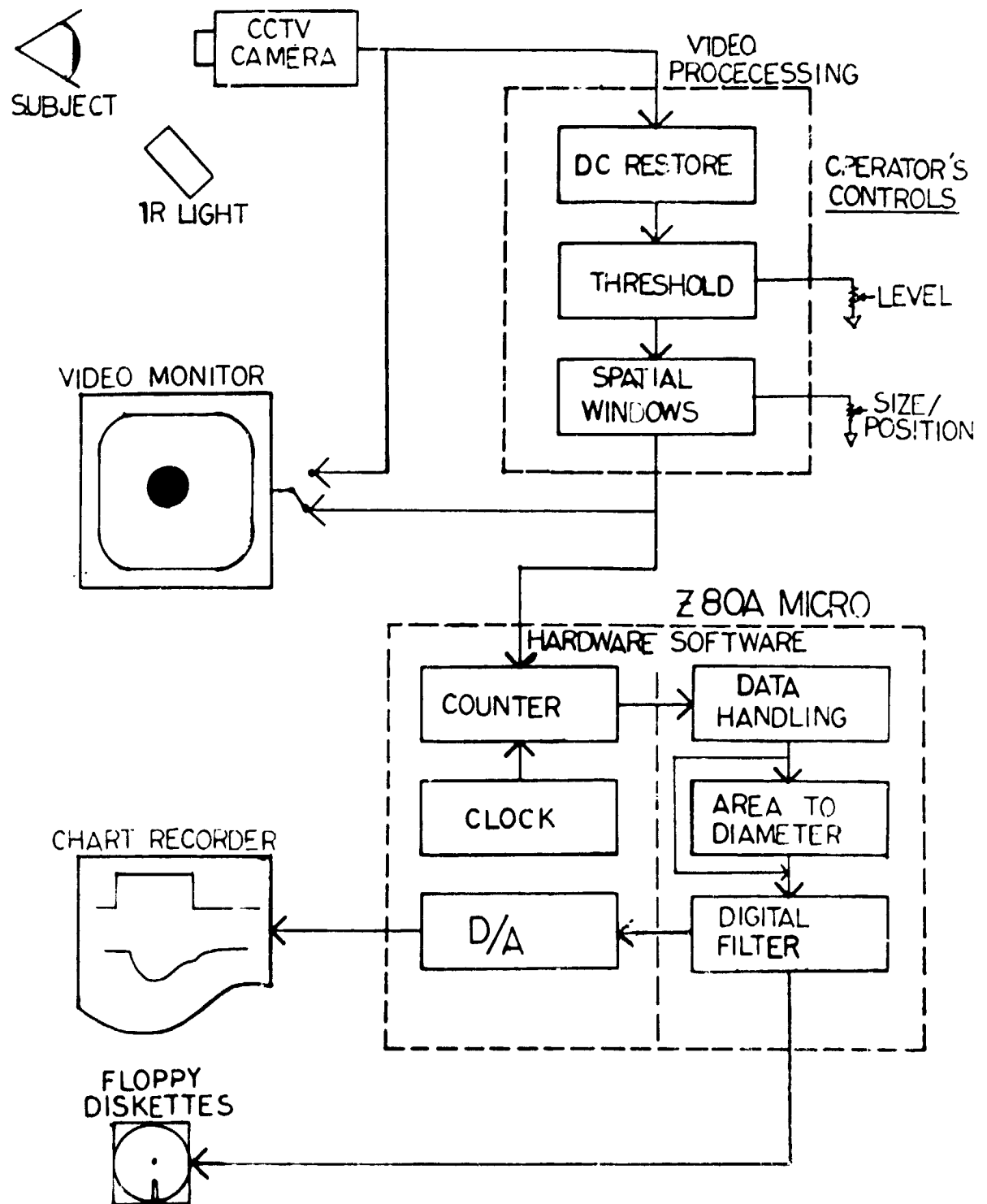

FIGURE 4 MICROPROCESSOR BASED INTEGRATIVE PUPILLOMETER (MIP)

counter to zero for the next frame.

The area may be (optionally) converted to diameter, and output to a digital to analog port. Pupil size (area or diameter) together with other input data (e.g. stimulus) is stored in buffer memory. When the buffer is full, it is automatically dumped to a floppy diskette.

#### SOFTWARE

The pupillometer was integrated into a microprocessor so as to provide the flexibility of software. Real-time software functions include: Data collection (described above), stimulus generation, area to diameter conversion (planned). Postprocessing may include correction for eye gaze, correction for optical imperfections, and filtering to remove instrument noise.

#### PERFORMANCE

The performance of the MIP is summarised in Fig. 5.

|  |              |
|--|--------------|
| SNR (MEASURED)   | 60 dB        |
| DYNAMIC RANGE  | 1-9 mm DIAM. |
| LINEARITY  | within .5%   |
| OPTICAL EFFECTS  | CORRECTABLE  |
| TEMPORAL BANDWIDTH                                       | 30 Hz.       |
| SPACIAL NOISE SENSITIVITY                                | LOW          |
| INHERENT S/N CHARACTERISTIC<br>(versus diameter methods) | 2:1          |

FIGURE 5 PERFORMANCE OF THE MIP.

ORIGINAL PAGE IS  
OF POOR QUALITY

EXPERIMENTATION

Linear Analysis

It is well known that the pupil control system is nonlinear in several respects. Nevertheless, the techniques of linear systems analysis provide valuable insight into its operation. Fig. 6 shows the system's response to a small-signal sinusoidal light stimulus, provided in Maxwellian view (open loop mode). The response is characterized by the gain and phase of the pupil area signal. Note that open loop gain is defined as:

$$G = \frac{\Delta A_p}{A_p} / \frac{\Delta L_p}{L_p}$$

where  $A_p$  is the area of the pupil  
 $L_p$  is the light incident on the pupil (and on the retina)

and hence is dimensionless.

If one plots gain and phase for a wide range of frequencies, a Bode plot (Fig. 7) results. Here we see that the pupil system has a high frequency rolloff (third order) at about 2 Hz. Terdiman and Stark (5) showed that this is due to the physiological limitations of the iris, which is a smooth muscle.

The data of Fig. 7 predict that, if the closed loop gain can be raised above 1.0 at about 1.2 Hz, where the phase delay is 120 degrees, oscillation will develop. If the stimulus light is carefully focused on the iris-pupil margin, (see Fig. 8) a change in pupil size results in a large change in the amount of light falling on the retina i.e. the gain has been greatly increased. When this is done for the subject of Fig. 7, the oscillations shown in Fig. 9 result.

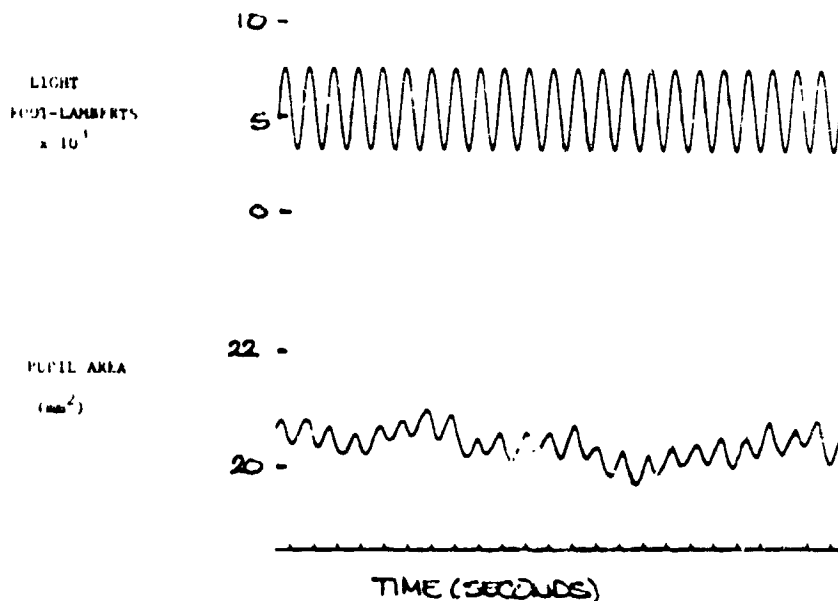
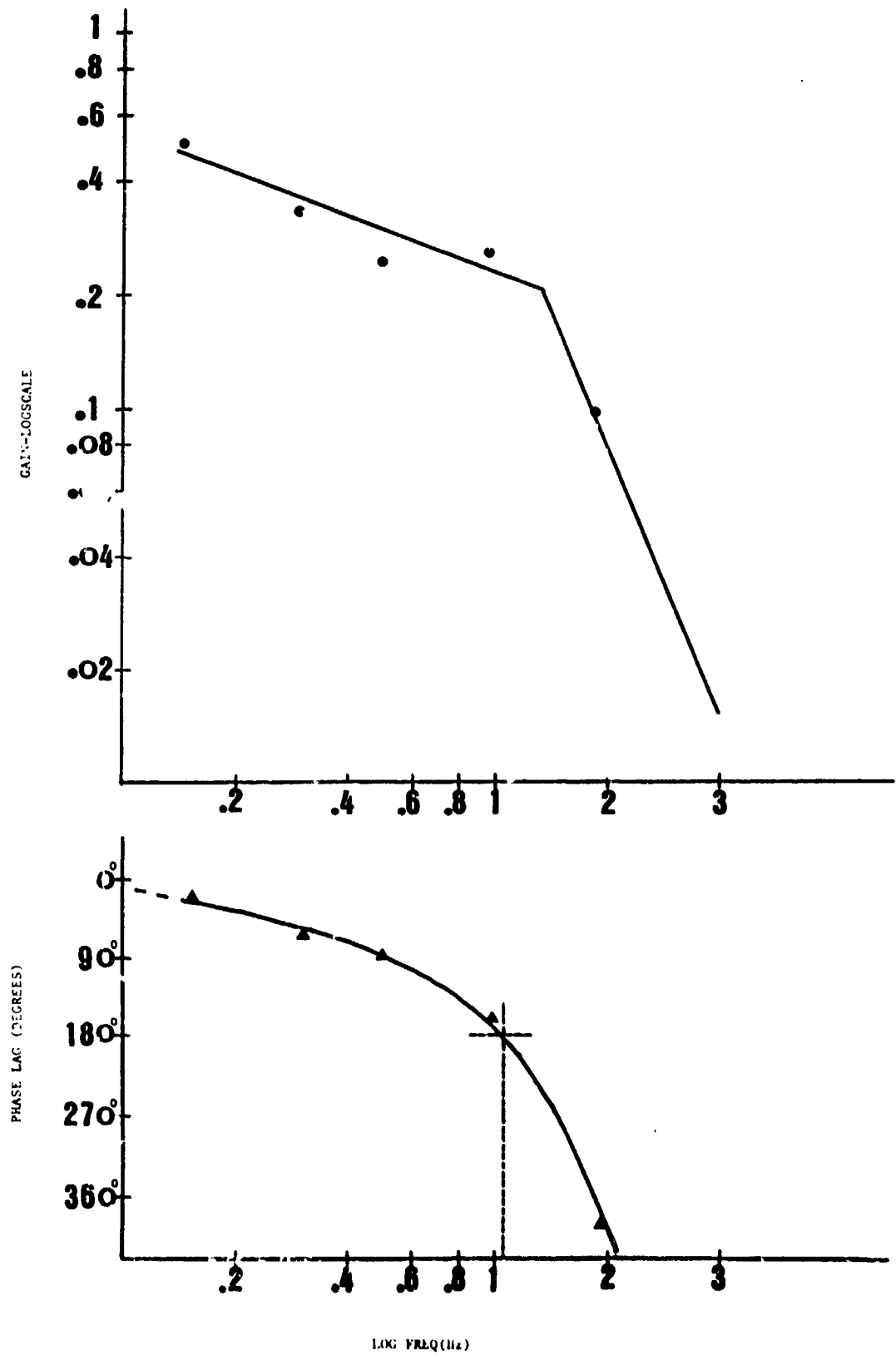

Figure 6 Quasilinear Response to Sinusoidal Light Stimulation.

frequency = 1.0 Hz. Modulation Coefficient = 0.02

FIGURE 7 BODE PLOT OF PUPIL RESPONSE FOR 1 SUBJECT  
 VERTICAL LINE REPRESENTS PREDICTED FREQUENCY  
 OF HIGH-GAIN OSCILLATION (180° PHASE LAG)



LOG FREQ(Hz)

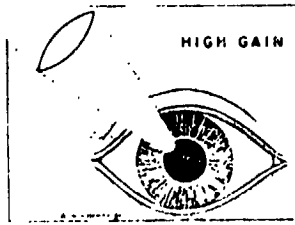

Figure 8 Technique used for stimulation. Light is here focused on border of iris and pupil. Small movements of iris result in large changes in light intensity at retina.

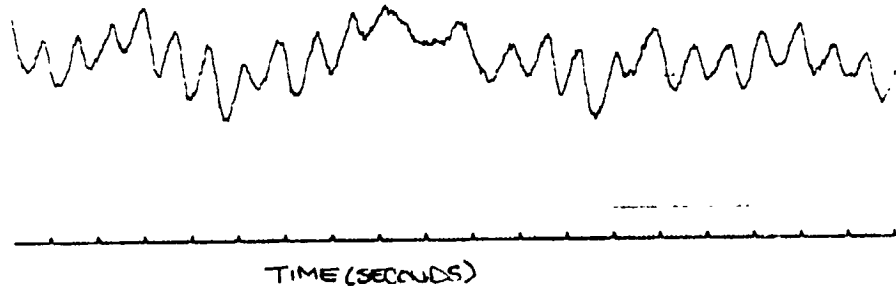

Figure 9 Spontaneous Oscillations Due to High Gain Feedback. Frequency = 1.3 Hz.

#### 10. Nonlinear Phenomena

The pupil exhibits many kinds of nonlinear phenomena. Obviously, it cannot constrict or dilate beyond physiological limits (extremal saturation), more generally, Hansmann, et al have shown that gain is a function of baseline pupil area. It is largest for a medium size pupil, and falls off at the extremes.

Harmonic and sub-harmonic responses may be seen in response to sinusoidal light stimulation. Subharmonics, illustrated in Figure 10, are most evident for large modulation coefficients, and at the system's low frequency band. In Figure 10 the harmonics resulted from a 2 Hz sine wave with 60% modulation. Harmonics are most evident during the low frequency sinusoidal excitation.



ORIGINAL PAGE IS  
OF POOR QUALITY

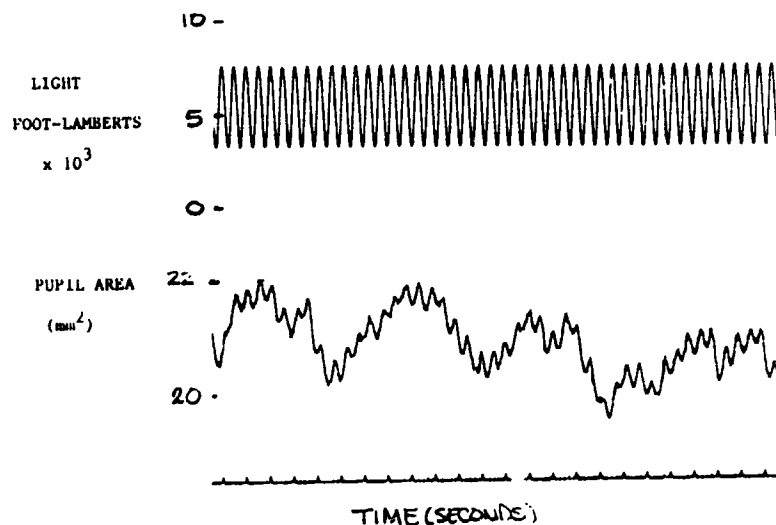

Figure 10 Subharmonic Response to Sinusoidal Light Stimulation

The response to a pulse stimulus (Figure 11) clearly shows a directional asymmetry. Regard the pulse as the sum of two step functions, a positive step followed by a negative step. The "on response" is clearly larger than the "off response". In fact, the off response is virtually absent for small pulses. Retinal adaptation allows for pupillary escape, that is for a readaptation of the pupil while the pulse of light is on. This is not a no-memory nonlinearity, and has to be modelled as a frequency dependent gain change.

#### SIMULATION

Shimizu developed a computer model of the pupil to simulate the effects illustrated in Figures 6 thru 11. A block diagram of the model is shown in Figure 13, and the corresponding results are shown in Figure 12.

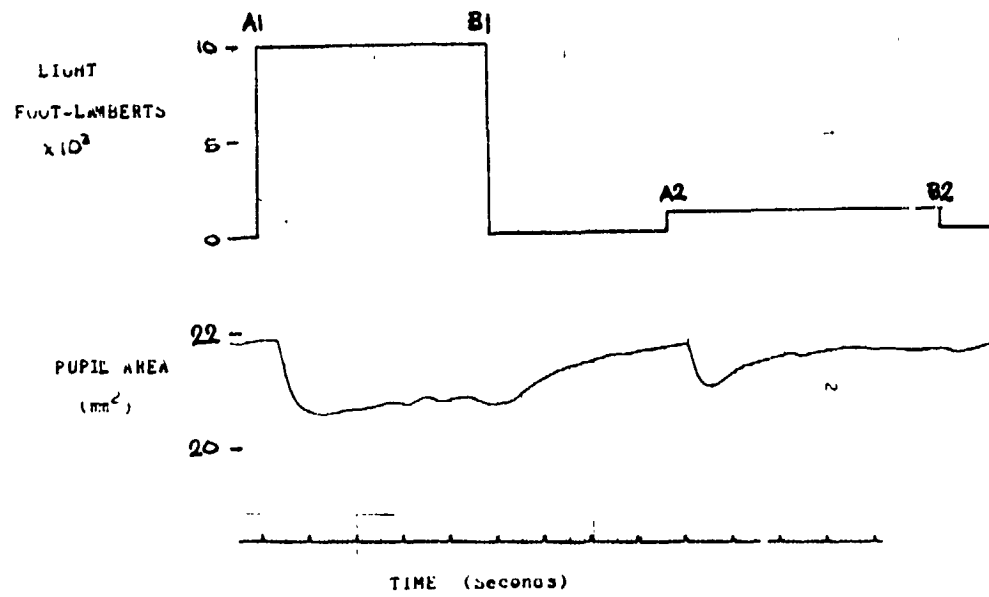

FIGURE 11. RESPONSE TO PULSES OF LIGHT SHOWING DIRECTIONAL ASYMMETRY, DIFFERENT TIME CONSTANTS OF RESPONSE, AND PUPILLARY ESCAPE

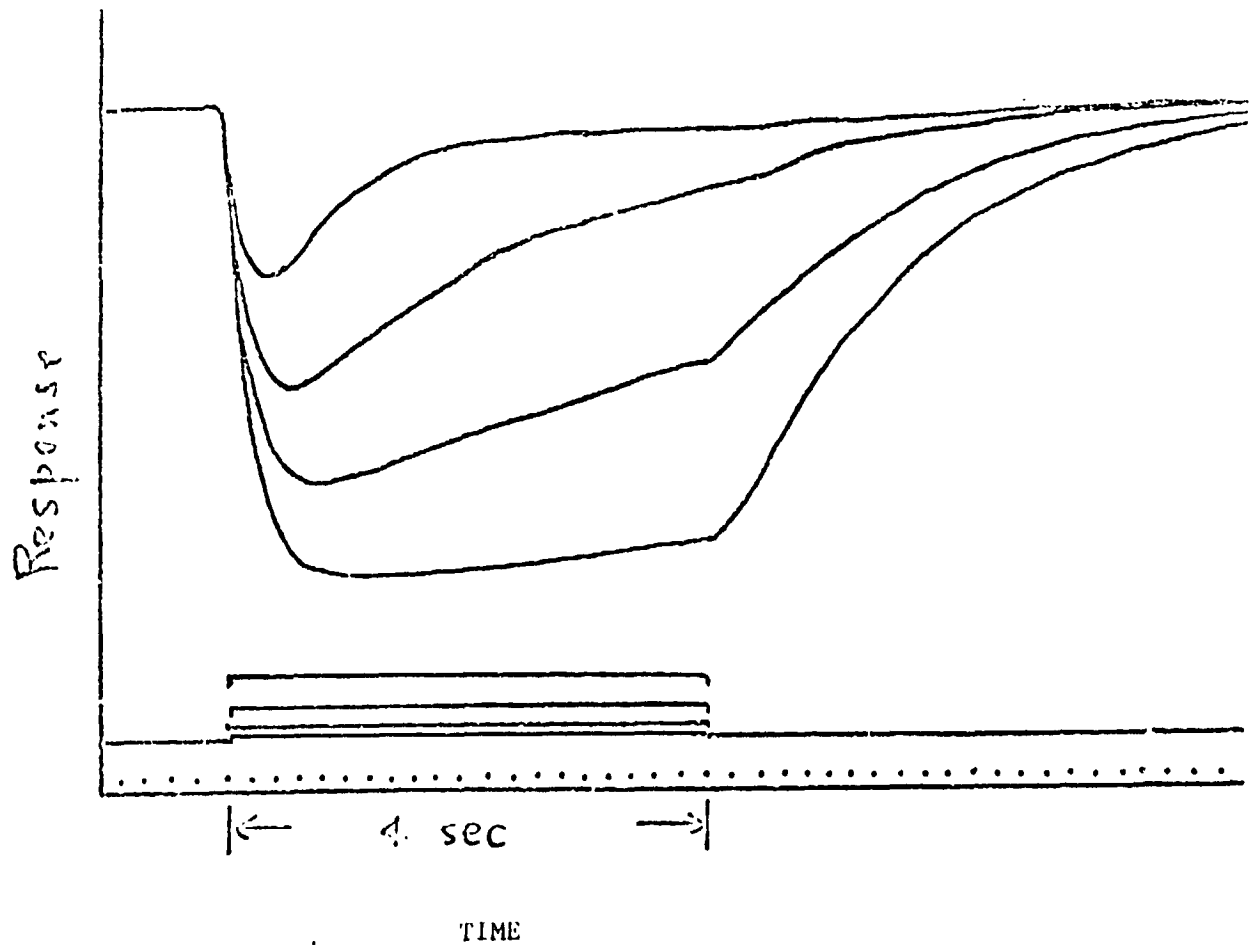

FIGURE 12 PUPILLARY ESCAPE SIMULATION RESULTS

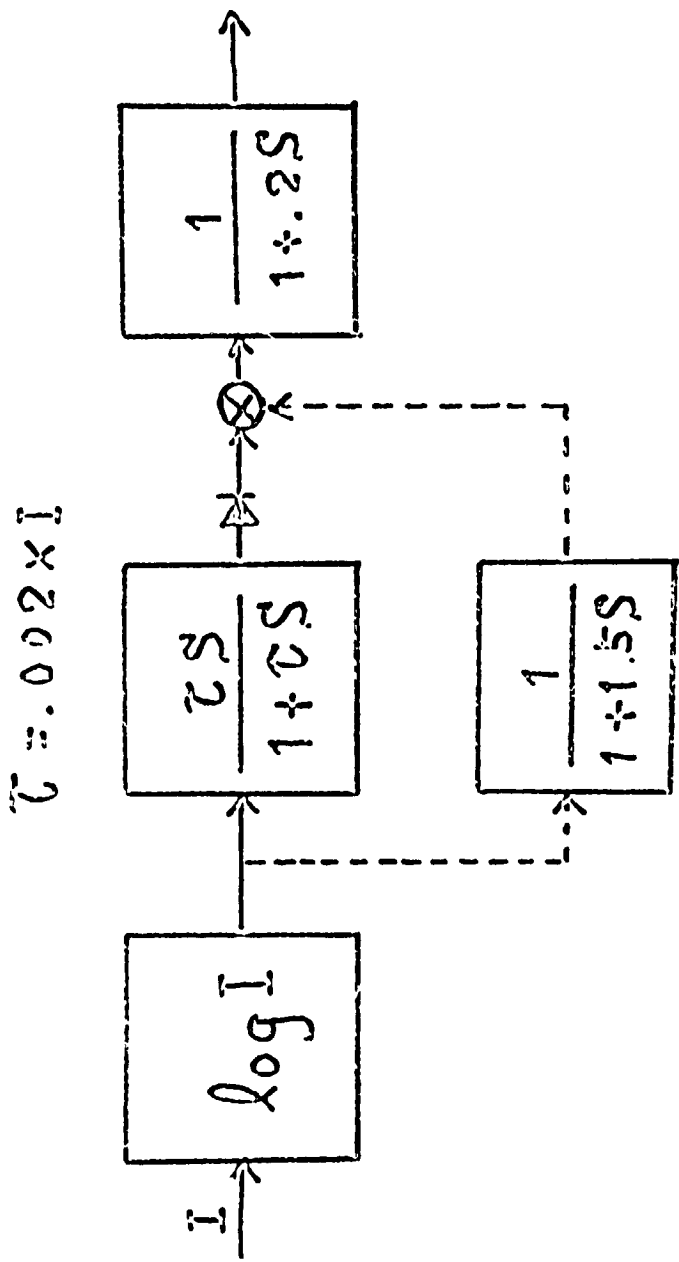

FIGURE 13. PUPILLARY ESCAPE MODEL

**ORIGINAL PAGE IS  
OF POOR QUALITY**

Acknowledgement

We are pleased to acknowledge the partial support from the NCC 2-86 Cooperative Agreement, NASA Ames Research Center, and from the NIH Systems and Integrative Biology Training Grant.

REFERENCES

1. Lowenstein, O. and Lowenthal, I.E., A.M.A. Archiv. Ophthalmol. vol. 37, no. 3, 362-363 (1950)
2. Start, L., P.I.R.E. vol 47, (1959)
3. Leddeman J., Smith J.D., and Start L. Brian Research vol 16 (1969) pp.283-297.
4. Hansman D., Semmelow J., and Start L. (1974) A Physiological Basis of Pupil Dynamics. In: Pupillary Dynamics and Behavior. (Ed. M.P. Janisse) Plenum, New York.