

TIME TRANSFER USING NAVSTAR GPS

A. J. Van Dierendonck, Q. D. Hua, J. R. McLean, A. R. Denz
Stanford Telecommunications, Inc. (STI), Sunnyvale, CA 94086

ABSTRACT

The NAVSTAR Global Positioning System (GPS) allows extremely accurate and global determination of time, as well as position and velocity. An STI Time Transfer Unit (TTU) developed for the U.S. Naval Observatory (USNO) has consistently demonstrated the transfer of time with accuracies much better than 100 nanoseconds. A new STI Time Transfer System (TTS), the TTS 502, is currently in development and will be available on the market by the end of 1981. The TTS 502 will be a relatively compact microprocessor-based system with a variety of options that will meet each individual's requirements, and will have the same performance as the USNO system. This paper summarizes the time transfer performance of that USNO system and presents the details of the new system.

INTRODUCTION AND SUMMARY

The NAVSTAR GPS is currently operating in its Concept Validation Phase (Phase I), while the operational system is under development. Rather than being repetitive on the description of the system, which has been described in numerous papers over the last 6 years, let it suffice to refer to a few of these papers in References 1 through 3. The important factor to note here, however, is that even though the system is not fully operational, it already provides the best overall time transfer capabilities in existence. Time transfer, using a Time Transfer Unit (TTU) designed and built for the U.S. Naval Observatory (USNO) by STI, has been demonstrated to be consistently better than 50 nanoseconds when done so with GPS satellites with good clocks.

Ultimately, GPS will allow continuous global determination of time when the complement of satellites in the system provides the appropriate coverage. (Only one satellite in view is required for time transfer.) At present, global determination is possible, but not continuously. Currently, the GPS program plan is to have an 18 satellite constellation⁴, which would provide global satellite visibility of 4-8 satellites above 5° elevation (7 satellites 28.7% of the time).⁵ The original planned constellation of 24 satellites would have provided visibility of 6-11 satellites above 5° elevation. A possible near-term constellation of six satellites will provide one satellite time transfer coverage ranging from approximately 16.5 to 20 hours per day, depending upon location. As it turns out, one of the worst time coverages is the

continental United States (and the Indian Ocean) because the constellation was designed to provide a clustering of satellites for testing at Yuma, Arizona.⁵ Examples of satellite coverage for those six satellites are presented in Figure 1.

The Time Transfer Systems, both old and new, operate on only the GPS L1 C/A (Clear/Acquisition) code at 1575.42 MHz. They do not operate on the L2 frequency (1227.60 MHz) because the C/A code will usually not be available on that frequency. The reasons for operating only on the C/A code are for simplicity and because, in the future, the P-code will not be available to all users. It will be obvious from later discussions that operating on the P-code would only improve the time transfer accuracy by about 30-35 nanoseconds (one sigma) when operating with large ionospheric propagation delays, to very little improvement when the delays are small. For most applications, this improved accuracy is not required, and for some users that need it, special purpose P-code time transfer systems can be developed.

The Time Transfer Systems also operate only from known surveyed (and stationary) locations. In future systems, position determination with limited motion is anticipated as an option. Position determination does degrade the time transfer accuracy because of Geometric Dilution of Precision (GDOP) and Time Dilution of Precision (TDOP) effects (see Reference 4 for definitions of GDOP and TDOP).

The USNO TTU is described in detail in References 7 and 8. This unit was delivered to the USNO late in 1979 and has been operating since mid-1980 very well.⁹ A summary of results obtained from this unit will be presented later in this paper. It has been instrumental in the determination of the long-term performance of the GPS frequency standards in orbit, as well as the performance of GPS time.

The USNO TTU, because it was the first Time Transfer System built, is a large and not so portable unit. Because of that, STI has developed a new TTS, the TTS 502, that has similar performance characteristics, but is relatively small, even to the point of being portable (a near future option). The unit is shown in Figure 2. Details of this new system are presented later in this paper.

Also presented in this paper are the techniques for accomplishing the time transfer, a time transfer error analysis, a description of various applications of the TTS and some future considerations for the use of GPS for time transfer.

TIME TRANSFER TECHNIQUE

For users with known locations, only one satellite signal is required for time transfer purposes. The time transfer technique employed is illustrated in Figure 3 which shows the timing relationships between

the system (GPS) time, satellite time, and the user's time when an epoch transmitted from the satellite (at GPS time T_T^{GPS}), arrives at the user's location (at GPS time T_A^{GPS}). Time transfer is accomplished by computing the user clock error, ΔT_A^U , with respect to system time, when an epoch is received. GPS satellites transmit continuous signals with readily identified subframe epochs every six seconds. The transmission time, T_T^{SV} , is determined by an on-board atomic standard which will, in general, differ by some amount, ΔT_T^{SV} from system time.

When the epoch arrives at the station, the transit time is measured as observed by the user. This measurement, called pseudorange (PR), is, in essence, the time difference between the user time at epoch arrival T_A^U , and the satellite time at epoch transmission, T_T^{SV} , i.e.,

$$PR = T_A^U - T_T^{SV} \quad (1)$$

In terms of system time, the pseudorange can be expressed as

$$PR = T_A^{GPS} - T_T^{GPS} - \Delta T_T^{SV} + \Delta T_A^U \quad (2)$$

The term $T_A^{GPS} - T_T^{GPS}$ is the "true" transit time (with respect to system time) representing the true time range, R , between the satellite and the station except for a propagation delay τ :

$$T_A^{GPS} - T_T^{GPS} = R + \tau \quad (3)$$

The user clock error is readily obtained from (2) and (3) as

$$\Delta T_A^U = PR + \Delta T_T^{SV} - R + \tau \quad (4)$$

The propagation delay includes the ionospheric and tropospheric propagation time delays and a receiver equipment bias.

A raw time transfer is performed every six seconds at the reception of the satellite signal epoch (subframe epoch) by the following procedure:

- o Deriving satellite (epoch) transmission time, T_T^{SV} , from the Z-count contained in the broadcast data subframe (inferred after initial synchronization).

- o Computing satellite clock error, ΔT_T^{SV} , and system transmission time, T_T^{GPS} , using clock correction parameters contained in the data frame.
- o Computing satellite position at system time T_T^{GPS} using the satellite's ephemeris contained in the data frame.
- o With the known user location, estimating the propagation delay τ using (1) ionospheric correction parameters contained in the data frame, (2) a simple tropospheric correction model, and (3) receiver equipment bias calibration data provided by the user during system initialization.
- o Computing the satellite-to-station range R , taking into account the effect of earth rotation during signal propagation.
- o Collecting a pseudorange measurement, PR , when the epoch arrives, and finally, computing the user clock time error ΔT_A^U according to equation (4).

These raw user clock time errors are then collected in a rotating buffer so that they can be smoothed to reduce the effect of the receiver noise and quantization errors. The smoothing is accomplished by applying a least squares fit on the values in the buffer. This smoothed error is then subtracted from the time of the epoch arrival to provide the GPS time of arrival

$$T_A^{GPS} = T_A^U - \overline{\Delta T_A^U} \quad (5)$$

where $\overline{\Delta T_A^U}$ is the smoothed user clock time error evaluated at user time T_A^U . However, the time transfer is accomplished by providing the user with a time pulse that is either coincident with T_A^U , along with the correction, or with a time pulse that has been corrected with the past best estimate of ΔT_A^U , and thus corrected to T_A^{GPS} or T_A^{UTC} . The corrected pulse is an option of the TTS. To correct to T_A^{UTC} , the epoch time of arrival in Universal Coordinated Time (UTC), a known difference between UTC and GPS time is applied. This known difference is presently supplied by the user. In the future it will be supplied in the GPS Navigation Message⁸.

THE TTS 502

A block diagram of the TTS 502 is shown in Figure 4. It is comprised of an STI Time Transfer Receiver Model 5026, an Omnibyte Motorola-based

MC68000 microcomputer and software, antenna, preamplifier and a display station. Also, options to the basic TTS-502 are illustrated. These options are:

- o 001 Precision internal 5 MHz crystal oscillator
- o 002 1 pps (pulse-per-second) output corrected to GPS or UTC time
- o 003 RS-232 interface for data output to external peripherals
- o 004 GPIB interface for data output to external peripherals
- o 005 Desk Top Cabinet Enclosure (not shown)

Other options will be added in the future and will be based on future user requirements. For example, for portability, an option for a portable chassis and a portable display and control terminal will be offered.

Timing Sources

The TTS's flexible relationship to external or internal frequency standards, oscillators, or digital clocks is illustrated in Figure 5, resulting in 3 time-source operating modes.

The TTS-502 can be controlled with a 3-position switch on the rear panel to operate in one of the following three modes:

Mode 1: Internal 5 MHz and Internal 1 pps Mode
(Internal 5 MHz with Option 001 only)

In this mode, an external 1 pps signal is not required. With Option 001, the TTS-502 includes a precision 5 MHz quartz crystal oscillator generating an internal 5 MHz signal from which all the required frequency references and timing pulses are generated when operating in Mode 1. The GPS time transfer is made with respect to an internally derived 1 pps signal. A TTS-502 with Option 001 can also operate in Mode 2 or Mode 3.

Mode 2: External 5 MHz and Internal 1 pps Mode

In this mode, a user-supplied external 5 MHz signal is used to derive all of the required frequencies and timing pulses. The TTS-502 uses the 5 MHz input signal to internally derive a 1 pps signal for referencing the GPS time transfer.

Mode 3: External 5 MHz and External 1 pps Mode

In this mode, a user-supplied external 5 MHz signal and a user-supplied 1 pps are input to the TTS-502. The GPS time transfer is made with respect to the externally supplied 1 pps signal.

In all of the above operating modes, the 5 MHz signal is passed through and available as an output at the rear panel. The 1 pps used to reference the GPS time transfer (internally derived in Modes 1 and 2, externally provided in Mode 3) is also available at the rear panel with the basic system. With Option 002, this pulse is time-shifted to correspond to GPS or UTC time.

Preamplifier/Antenna

The preamplifier and antenna, which are included in the TTS-502 system, are off-the-shelf items. The preamplifier is an Avantek AM1664 modified to accept power via the RF cable to the receiver and high power input protection (Avantek M1664N103). This preamplifier is tuned to the L1 frequency with a minimum of 50 dB gain, and a noise figure of 3 dB and a bandwidth of 10 MHz. This will insure a receiver system noise figure of less than 4 dB, even for installations with very long preamplifier-to-receiver cable lengths. Its size is approximately 8 inches by 3 inches by 2 inches, including connectors.

The antenna is an omni-directional antenna. It is right-hand circular polarized and has greater than -2 dBIC gain above 10° elevation angle and greater than -3 dBIC gain above 5° elevation angle with hemispherical coverage (measured on a ground plane).

Receiver/Processor

A block diagram of the Receiver/Processor subsystem of the TTS-502 is shown in Figure 6. This subsystem is the portion of the TTS that is housed in the 8-3/4-inch chassis shown in Figure 2 (which includes the Option 001 oscillator, if provided). The receiver has its baseband processing and control resident in firmware in a microprocessor. The receiver hardware consists of a downconverter, correlator, code generator, code and carrier NCO's (Number Controlled Oscillators), frequency synthesizer and timer and a 115 volts, 60 cycle, (both ±10%) power supply which also supplies DC power to the preamplifier. The receiver operates on the L1, C/A code signals only, and in conjunction with the microprocessor, acquires the satellite signals, tracks the code and carrier of the acquired signal, demodulates the navigation data, performs parity checking on the data, measures pseudorange and doppler and provides the data and measurements, upon request, to the MC68000 microprocessor. That control will occur at a maximum rate of once per second, either as an acquisition command or as a measurement request.

The receiver accepts the L1 C/A RF signal from the preamplifier. Its sensitivity is better than 132 dBm (at the preamplifier) and it has a dynamic range of greater than 20 dB, with a spurious response greater than 60 dB at 130 MHz from the carrier. Its 3 dB IF bandwidth is 25 MHz. Its pseudorange measurement resolution is 48.9 nanoseconds, which, in the time transfer algorithms, is smoothable down to a one sigma of 0.9 nanoseconds.

The MC68000 microprocessor, in addition to controlling the receiver, contains all of the time transfer software (firmware). Its basic duty cycle for computing time transfer values is once per six seconds. Some of the basic features of this processing are described below.

Time Transfer Software Processing

The TTS software package resident in the MC68000 microprocessor is written primarily in a FORTRAN language. However, the entire software system will be compiled and "burned" into Programmable Read Only Memories (PROM's) on the microprocessor card. In addition to volatile Random Access Memory (RAM) available for processing, nonvolatile RAM is used to store initialization parameters to circumvent reentering those parameters whenever power is lost or removed and then restored.

The software routines are designed to perform a variety of functions: operator input handling, receiver signal acquisition control, satellite data collection and processing, scheduling and schedule control, time transfer algorithm execution, data smoothing, data statistical analysis, data display, data output, etc.

The primary purpose of the software processing is to provide the user the flexibility of exercising various modes of operation to suit his requirements. Most important, the software processing provides an automatic mode of operation in which visible satellites are scheduled to be tracked under software control, permitting continuous time transfer operation. Once this mode is initiated, no further operator intervention is required, and the TTS is operated in a so-called "do forever" loop.

The TTS with its application software processing is designed primarily for the automatic controlling of the receiver to track a sequence of visible satellites based on a 24-hour tracking schedule, in support of continuous time transfer operation. The TTS provides two modes of control for setting up this schedule.

Under the full automatic mode of control, a 24-hour satellite tracking schedule is generated internally by the software based on a stored almanac and known user location. The criterion used for generating a schedule is such that every satellite chosen by the operator will be tracked at least once every day. This schedule is automatically

revised daily to account for the GPS satellite constellation precession. To override the full automatic schedule, the user may exercise the semi-automatic mode of control in which the user is allowed to set up a 24-hour schedule using any criterion he may choose.

In either mode, once a schedule is set up, it will be maintained by the program and, at the beginning of each tracking interval, the receiver will be automatically reset with a new satellite identification number and initial doppler estimate computed using stored almanac data. Since almanac data for all satellites are updated occasionally by the GPS Master Control Station, the stored almanac data to be used by the system are continuously and automatically refreshed once the system is in operation.

Starting with a new satellite acquisition command, the time transfer operation proceeds through three phases of operation. In the first phase, the signal acquisition phase, the receiver will acquire and track the selected satellite. During this phase, the receiver acquisition process is monitored by the program until the signal is successfully acquired and subframe synchronization is achieved. In the next phase, the initial data acquisition phase, satellite data subframes demodulated by the receiver are input and processed every six seconds until a complete set of error-free data is collected. Normally, these two phases will take much less than one to two minutes, depending upon whether time had been previously established. The final phase, time transfer solution phase, will last for the rest of the scheduled time. This phase consists of a number of time transfer cycles, each cycle occurring at 6-second subframe epochs.

At the beginning of each cycle, the processor inputs a 300-bit data subframe, receiver status information, and measured pseudorange and doppler from the receiver. Pseudorange and doppler measurements are taken every second and combined at the end of six seconds to provide a smoothed measurement for the time transfer computations. The receiver status information is used for monitoring the receiver performance, and for accessing the validity of the measured pseudorange. The purpose of the data subframe is threefold: first, to derive the satellite time of transmission from the subframe Z-count; second, to refresh satellite navigation and almanac data; and finally to check if the navigation data is being updated by the satellite. If so, a new set of satellite ephemeris data will be collected to keep the microprocessor data base current.

The time transfer algorithms are then applied to estimate user clock time error, to enter that error into the time offset smoothing process, to display data in a variety of forms, based on user's selected options, and to output data to the optional output ports. Typical displays show the station clock time error, the time of day (in GPS or UTC time),

date (in Modified Julian Date Number), age of data, receiver status, satellite identification number, and elevation and azimuth angles.

Besides the two major modes of operation described above, the TTS software processing also provides additional modes of operation which allow the user to initialize the data base, collect an initial set of almanac data, to obtain satellite constellation times of visibility, and to exercise the manual mode of control in which a particular satellite of interest can be tracked until terminated or until it is no longer in view.

TIME TRANSFER ERROR ANALYSIS

Various sources of error that could affect the accuracy of the time transfer to varying degrees are listed in Table I and are discussed below.

Satellite Group Delay and Clock Errors

Normally, satellite group delay, which is caused primarily by delays in satellite signal paths, are indistinguishable from the satellite's clock time offset. Therefore, they are included in the GPS Control Segment's estimate of that clock offset. However, that estimate is based on dual frequency (L1 and L2) measurements of pseudorange, absorbing any group delay differential between the L1 and L2 signal paths within the satellite. This differential has no effect on two-frequency users. However, since the TTS has an L1 only receiver, that differential, multiplied by a factor of 1.546, is not accounted for in the polynomial clock correction terms of the Navigation Message.¹¹ However, it is accounted for in the TGD term included in that message. The error in that term is affected, however, by the Control Segment's ability to measure it through the ionosphere at times of relatively small ionospheric delays. However, that error, along with perturbations in the absolute group delay in the satellite, is expected to be insignificant compared to the satellite's random clock drift described below. Therefore, they can be neglected.

The satellite clock errors are basically the error in the satellite's polynomial clock correction terms of the Navigation Message. That error is caused by three sources: the satellite's random clock drift, the group delay described above, and the Control Segment's inability to estimate and predict the clock drift exactly. These errors are very much related, so it makes no sense to try and differentiate them. Over a period of time, however, the random clock drift will normally dominate if the satellite's clock is reasonably stable. (In other words, a clock is one that meets specification - a nonanomalous satellite.) That assumption is made here, since that is the case for all but the first two satellites launched. In fact, the most recently launched satellites have very stable clocks.

Since these clocks do vary in stability, it makes more sense to discuss the specified stability rather than the actual stability. The numbers in Table I reflect those specifications^{12,13}. For the Phase I satellites, the clock errors were specified for only two hours after upload of the satellite, obviously to cover specific testing periods. However, since the TTS could be used anywhere, that error budget has been extended to 24 hours here, using the clock Allan variance characteristics provided in Appendix III of Reference 13 and the time drift models of Reference 14. Since there are two types of frequency standards operating in the Phase I satellite (Rubidium and Cesium), a range is given for the clock error budget of 25.5-108 nanoseconds (one sigma) for 24 hours after upload (25.5 for Cesium, 108 for Rubidium). These are based on the equations:

$$\begin{aligned} \sigma^2(t) = & 10^{-20}(t-t_{\text{UPLOAD}}) \\ & + 1.44 \times 10^{-24}(t-t_{\text{UPLOAD}})^2 \text{ seconds}^2 \end{aligned} \quad (6)$$

for the Rubidium standard, and

$$\begin{aligned} \sigma^2(t) = & 2.5 \times 10^{-21}(t-t_{\text{UPLOAD}}) \\ & + 5.76 \times 10^{-26}(t-t_{\text{UPLOAD}})^2 \text{ seconds}^2 \end{aligned} \quad (7)$$

for the Cesium standard.

Although the drift of the Rubidium standard causes the TTS error budget to exceed the 100 nanoseconds advertised, the standards that are operational have been performing much better than specified.

For the operational GPS system, the Operational Control Segment (OCS) is simply specified to upload the satellites as often as required to maintain the combined clock and ephemeris errors to within 20 nanoseconds (6 meters), one sigma.

The nature of these clock errors are basically bias-like over the smoothing interval of the TTS (240 seconds, maximum).

Satellite Ephemeris Prediction Errors

These errors are primarily the Control Segment's inability to predict the satellite's ephemeris (position versus time) exactly plus any perturbations that are unpredictable. These errors, along the line-of-sight to the user, are budgeted to be 12 nanoseconds (3.6 meters), one sigma for the Phase I system for 24 hours after upload, and are combined with the clock errors as described above for the operational system. Actually, the errors are somewhat negatively correlated with the clock errors and tend to cancel somewhat over short periods of

time after upload. Therefore, it makes more sense to combine the error budget as it is for the operational system.

As for the clock errors, the ephemeris errors are basically bias-like over the smoothing interval of the TTS.

Ionospheric/Tropospheric Delays/Multipath Errors

These errors are obviously independent of each other; however, they are worse at low elevation angle tracking and minimized at higher elevation angles. The multipath errors can be controlled with good installation practices. They can also have a relatively random component that could be lumped in with the receiver noise errors. The tropospheric delay is corrected with a simple model.

In any event, the ionospheric delay correction error will usually dominate, since the TTS has no capability of measuring pseudorange at two frequencies. It must rely on the ionospheric correction model provided in the Navigation Message.^{10,15} In fact, under normal situations, the ionospheric delay correction error will dominate the TTS performance.

Reference 15 treats this correction error in detail. In summary, the ionospheric delay error is caused by the integrated electron content along the ray path between the satellite and the user. The delay effect is dependent on both the character of the ionosphere at the zenith and the elevation angle to the satellite. The character at zenith is highly dependent on geometric latitude of the user and the time of day, and is not very predictable. Figure 7 shows typical measurements of ionospheric delay for an L-band signal (near L1) received at vertical incidence.¹⁶ The mean ionospheric delay at nighttime is on the order of ten nanoseconds. During the daytime the mean delay increases to as high as fifty nanoseconds. At low elevation angles the delay can be up to three times the values given above (30-150 nanoseconds). Although these delays are partially corrected with the Navigation Message model, that model will normally be in error by about 50 percent of the delay (one sigma).¹⁵ Therefore, as a "ballpark" estimate, it is assumed that the ionospheric delay correction error, combined with the tropospheric correction and multipath error, ranges between 5-40 nanoseconds (one sigma), depending upon many variables. This error is the most important error source of the TTS time transfer error.

Receiver Noise (and Random Multipath) Errors

Receiver noise is dominated by the thermal noise effects on the performance of the receiver's code loop (neglecting unintentional jamming, of course). Since the TTS receiver's code loop is aided by its carrier loop, and because pseudorange measurements are relatively infrequent

(once per second), its loop bandwidth is quite small, reducing the raw measurement receiver noise error to 15.5 nanoseconds, one sigma. Smoothing to one-second measurements reduces this error to 6.3 nanoseconds, one sigma. Also, this error is random in nature; therefore, since the TTS software processing smooths the raw time transfer results, this 6.3 nanoseconds can be further reduced to about 1.0 nanoseconds, one sigma (40 sample smoothing).

Pseudorange Quantization Errors

The least significant bit of the TTS pseudorange measurements is worth 48.9 nanoseconds (1/20th of a C/A code chip). This is reduced by the square root of 12 to a one sigma value of 14.1 nanoseconds, since it is a uniformly distributed error between ± 24.4 nanoseconds. (The bias is a time error that is part of the receiver's calibration correction, primarily because pseudorange, as measured, is always positive). As was the case for the receiver noise errors, these quantization errors are further reduced in the TTS software processing because they are smoothed, reducing the 14.1 nanoseconds down to about 5.8 nanoseconds, one sigma for the smoothed 6-second measurement and down to 0.9 nanoseconds, one sigma, in the time transfer smoothing (40 sample smoothing).

User Location Estimation and Receiver Bias

The TTS makes use of the user coordinate in the estimation of satellite-to-user range, and therefore must be known accurately. The error budget for this estimation depends on the surveying technique used to determine the coordinates. If a GPS Geociever is used for the survey, the GPS position can be derived quite accurately, to within about 1-2 meters^{17,18} ($\cong 5$ nanoseconds). Otherwise, the location error could be somewhat larger, and budgeted to be up to about 5 meters (15 nanoseconds), one sigma. This error is bias-like, and therefore cannot be smoothed over the TTS smoothing intervals.

The TTS receiver bias from the antenna to the input (or output) 1 pps, is calibrated prior to TTS delivery. The error and subsequent drift in that bias is well within the location error budget given above. Of course, any cable length changes require a new bias input.

Total (RSS) Time Transfer Error Budget

Table I lists the various individual error budget that makes up the total TTS time transfer error budget. The RSS totals are given as ranges, consistent with the ranges given for the individual budgets. Also, the smoothed error budget is given versus the raw error budget, assuming 40 sample smoothing (6 seconds per sample). For the Phase I GPS error budget, two totals are given - one for the Rubidium satellite frequency standards and one for the Cesium satellite frequency

standards. All budgets are well within the advertised budget of 100 nanoseconds for the TTS, except for worst case Rubidium frequency standard drifts, which to date have not been exhibited.

USNO TTU RESULTS

Acceptance Test Results

The acceptance tests of the USNO Time Transfer Unit were conducted for five days in November 1979, as part of the unit acceptance tests. The following is an excerpt from a paper by Dr. Kenneth Putkovich⁸, USNO representative at the time of the acceptance tests.

"Initial tests of the time transfer capability of the Time Transfer Unit (TTU) were carried out as part of the unit acceptance tests. A pair of portable atomic clocks was carried to the MCS (Master Control Station) at Vandenberg AFB in California. The ensemble of atomic clocks which constitute the GPS master clock were measured against the portable clocks with particular attention to the clock serving as reference for the Vandenberg Monitor Site. Pertinent system delays in the monitor receiver were also measured and verified with site personnel. The portable clocks were then transported to the STI facility in Sunnyvale, where a series of time transfers were made using the portable clocks as reference for the TTU. The clocks were then returned to Vandenberg (to establish a baseline for GPS time) and then taken back to Sunnyvale for a final series of measurements. The results of this initial series of measurements are presented in Figure 4 (Figure 8 in this paper). As can be seen from the plot, time transfers with a precision of better than ± 50 nanoseconds were achieved."

After the portable atomic clocks were shipped back to USNO, additional testing was performed, this time using a Cesium standard which was calibrated against the atomic clocks. These tests also produced similar results.

Subsequent Testing and GPS Time Performance Monitoring^{8,19}

Subsequent tests performed by the USNO involved the verification of GPS Time at the GPS Master Monitor Station via portable clocks and the acquisition and tracking of as many passes of the satellites currently in operation as possible. These tests resulted in the same level of performance as the initial acceptance testing, but revealed what appeared to be several discontinuities in GPS Time. An investigation showed the cause of these steps to be GPS master clock changes and failures in GPS Monitor Stations. Since then, due to a coordinated effort between USNO and the GPS program office, an improvement has been made as the magnitude and frequency of the discontinuities has decreased. More details of GPS Time monitoring are given in Reference 19, which covers a period of time up through about the end of 1980.

The TTU has also been used to monitor the performance of the frequency standards in the GPS satellites. Those performances are also presented in Reference 19 over the same time frame and have also been presented in terms of Allan variance numbers in Reference 20. That performance is monitored by "backing out" the satellite clock correction polynomial derived from the GPS Navigation Message¹¹, which basically "uncorrects" the satellite clock time from GPS Time to the time of the satellite's subframe epoch transmission. In a sense, the accuracy in this TTS estimate of satellite time is better than that of GPS Time because it is not corrupted by the prediction errors in the clock correction polynomial, which is evident from results presented in Reference 19. However, this estimate is of little value to the normal TTS user, unless he is primarily interested in monitoring satellite clock performance, with one exception. Since the USNO publishes the difference between their Master Clock and each satellite's clock, a user can perform a time transfer to UTC via a satellite clock instead of via GPS Time. The published difference of a good satellite clock is more accurately predictable by extrapolation than that of GPS Time to the user's time of transfer. However, if the user does not extrapolate and uses data common to the USNO after the fact, it makes no difference because the clock correction polynomial prediction errors cancel. (In fact, in a common view time transfer performed while in communication with the USNO, all common errors such as satellite clock errors, ephemeris prediction errors, and part of the ionospheric delay correction errors cancel, resulting in a more accurate time transfer. This has been suggested and demonstrated by the National Bureau of Standards.^{21,22}).

USNO GPS Time Service

Data from the GPS satellites are recovered daily by the USNO and are made available through the USNO Time Service Automated Data Service (ADS) via standard dial-up telephone line, using a modem and terminal. (See Reference 19.) This service was used to obtain more recent data than that presented in Reference 19 for a satellite that has had a Cesium beam standard operating for some time (SV#9). The data was retrieved for a period of 190 days starting on January 1, 1981. The results provided by the Time Service are plotted in Figure 9 for both the difference between GPS Time and the USNO Master Clock and the difference between SV#9's clock and the USNO Master Clock. The following polynomials (three point derived) were removed from the data before plotting:

$$\begin{aligned} \text{GPS Time: } & -35.811 \mu\text{s} - 1.3352 \times 10^{-12} \text{ s/s } \times t & (8) \\ & + (2.81436 \times 10^{-15} / 86400) \text{ s/s}^2 \times t^2 \end{aligned}$$

$$\begin{aligned} \text{SV\#9 Time: } & 346,428 \text{ ns} + 3.6651 \times 10^{-13} \text{ s/s } \times t & (9) \\ & + (6.04051 \times 10^{-16} / 86400) \text{ s/s}^2 \times t^2 \end{aligned}$$

where t is in seconds since 1 January. These coefficients are equivalent to drift values of:

$$\begin{aligned} \text{GPS Time: } \Delta f/f &= -1.3352 \times 10^{-12} \\ D &= 5.62872 \times 10^{-15}/\text{day} \end{aligned}$$

$$\begin{aligned} \text{SV\#9 Time: } \Delta f/f &= 3.6651 \times 10^{-13} \\ D &= 1.2081 \times 10^{-15}/\text{day} \end{aligned}$$

It is evident from these plots that the satellite's clock is better than the GPS clock. This should be expected since the GPS clock is much older than the satellite's clock. The fact is that both clocks are exhibiting normal "flicker" characteristics. The anomalous results that occurred around day 130 are due to transient conditions in the GPS system after a "Master" receiver failure. Time in the master GPS clock was reinitialized.²³

The results of Figure 9 are consistent with the results presented in Reference 19 for a previous period of time.

TIME TRANSFER APPLICATIONS

The Time Transfer System can be employed in a variety of applications. As a stand-alone system it can provide an absolute time reference for users within GPS. By using the data provided by USNO's Time Services, GPS Time (or any of the SV times) can be translated to UTC. More stable timing can be achieved by operating the TTS with an external Cesium or Rubidium standard to bridge periods of nonvisibility to satellites in the current GPS system. Intermittent accurate time transfer can be achieved with the optional internal crystal oscillator, with accuracies on the order of microseconds during periods of nonvisibility.

The TTS can also be used as a calibration device to provide time alignment of other standards in the user's timing network.

For a timing network in which only relative time is required, the so-called "common mode-common view" technique of time transfer can be employed to provide even better accuracy.²¹ In this mode, a highly stable TTS is used as the master clock (such as the one at USNO) and another TTS at a remote location will be simultaneously scheduled to track an identical satellite that is visible from both TTS's. When the time offsets obtained from these two TTS's are compared, better (relative) accuracy will be achieved due to the cancellation or reduction of common sources of error, e.g., satellite clock and ephemeris error, and some of the atmospheric time delay error.

As an example, Figure 10 shows the times that two TTS's located in Washington, D.C. and Paris, France may both see a particular satellite. Note that, even with the six-satellite constellation, the daily common view period can be as much as 15 hours.

This technique is similar to that employed in TV line-10 transfers, where simultaneous, common view measurements against a stable transmitter yield measurements with ten-nanosecond uncertainty. Intercontinental time transfer at ten nanoseconds should be possible with GPS TTS's.

FUTURE CONSIDERATIONS

In the near future, the TTS 502 will be available in a portable configuration. The receiver/processor chassis will be packaged as a portable unit. The preamplifier and antenna are already quite portable. Portable terminals are also available on the market or may already be available at remote sites. And the TTS does not need batteries. It can be plugged into any 115 VAC wall socket. Initialization parameters can be stored in nonvolatile memory (or PROM) at a laboratory or depot site, and the TTS can be shipped unattended to a remote site as a calibration device. The only starting parameter that is needed is an approximate time-of-day and day-of-year, which could conceivably be entered with other means besides a terminal (such as a set of thumbwheels, a start button, and an LED readout), eliminating the need for a terminal.

As the number of TTS's increase, they will become smaller than "Flying Clocks," and competitive in price. They are already lighter (no batteries), and much less expensive to maintain and transport (again, no batteries).

As GPS matures and more satellites become available, it is also conceivable that the TTS's will also replace frequency standards in the field. Over the short term they are not quite as accurate, but over the long term they will be nearly as accurate as UTC itself (± 100 nanoseconds or less). And, they will never need calibrating. As with the flying clocks, the TTS will also eventually become competitive in price with accurate frequency standards.

ACKNOWLEDGMENT

The authors wish to thank Dr. Gernot Winkler and Dr. Kenneth Putkovich and their staff at USNO for their helpful response to inquiries made to them regarding the subject matter of this paper.

REFERENCES

- 1) GPS Special Issue, Navigation: Journal of the Institute of Navigation, Summer of Navigation, Summer 1978, Vol. 25, No. 2.

- 2) "Global Positioning System," Papers published in Navigation: Journal of the Institute of Navigation, 1980.
- 3) "Principles and Operational Aspects of Precision Position Determination Systems," AGARDograph No. 245, edited by C. T. Leondes, North Atlantic Treaty Organization Advisory Group for Aerospace Research and Development, July 1979.
- 4) P. S. Jorgensen, "Navstar/Global Positioning System 18 - Satellite Constellations," Navigation: Journal of the Institute of Navigation, Summer 1980, Vol. 27, No. 2.
- 5) P. S. Jorgensen, "Navstar Global Positioning System 18-Satellite Constellations," Air Force Systems Division GPS Constellation Briefing, June 5-6, 1980.
- 6) W. F. Brady and P. S. Jorgensen, "Worldwide Coverage of the Phase II Navstar Satellite Constellation," presented at the Institute of Navigation National Aerospace Meeting, Trevese, PA, 8-10 April 1981.
- 7) Q. D. Hua and H. A. Bustamante, "A GPS Time Transfer System," presented at Second Annual AFCEA Communications Electronics Exhibit and Technical Symposium, Palo Alto, CA, 12-14 November 1980.
- 8) K. Putkovich, "Initial Test Results of USNO GPS Time Transfer Unit," presented at 34th Annual Symposium on Frequency Control, May 1980.
- 9) Private Communication with Dr. Gernot Winkler, USNO, July 1981.
- 10) Navstar GPS Space Segment/Navigation User Interface, (Draft), ICD-GPS-200, Rockwell International Interface Control Document, May 27, 1981.
- 11) A. J. Van Dierendonck, S. Russell, E. Koptizke, and M. Birnbaum, "The GPS Navigation Message," included in References 1, 2, and 3 above.
- 12) "System Specification for the Navstar Global Positioning System, Phase I," U.S. Air Force Space and Missile Systems Organization document SS-GPS-101B, 15 April 1974.
- 13) "Requirements for the Control Segment of the Navstar Global Positioning System," U.S. Air Force Space Division (AFSD) document No. YEN-78-019, Revision VI, 10 March 1980.

- 14) A. J. Van Dierendonck, "Opportunities and Limitations with Satellite-Borne Time and Frequency Navigation Systems," lecture given at National Bureau of Standards Seminar on Time and Frequency Control, August 1977.
- 15) J. A. Klobuchar, "A First-Order, Worldwide, Ionospheric Time-Delay Algorithm," U.S. Air Force Cambridge Research Laboratories Report No. AFCRL-TR-75-0502, 25 September 1975.
- 16) B. D. Elrod, "Correction for Ionospheric Propagation Delay in ASTRO-DABS - The Dual Frequency Calibration Method," Mitre Report, MTR-6896, April 1975.
- 17) Patrick Fell, "Geodetic Positioning Using a Global Positioning System of Satellites," presented at IEEE Plans 80 Position, Location, and Navigation Symposium, Atlantic City, N.J., 8-10 December 1980.
- 18) J. M. H. Bruckner, R. W. Carroll, N. B. Hemesath, W. M. Hutchinson, "Low Cost-High Accuracy GPS Survey Receiver Design," presented at 13th Annual Offshore Technology Conference, Houston, Texas, 4-7 May 1981.
- 19) K. Putkovich, "USNO GPS Program," paper presented at 12th annual PTTI Applications and Planning Meeting, NASA Goddard Space Flight Center, Greenbelt, MD, 2-4 December 1980.
- 20) M. Levine, paper presented at 35th Annual Symposium on Frequency Control, May 1981.
- 21) Allan, D. W. and Marc A. Weiss, "Accurate Time and Frequency Transfer during Common-View of GPS Satellite," Proceedings, 34th Annual Frequency Control Symposium, Fort Monmouth, NJ, May 1980.
- 22) Davis, D. D., M. Weiss, A. Clements, and D. W. Allan, "Unprecedented Syntonization and Synchronization Accuracy via Simultaneous Viewing with GPS Receivers; Construction Characteristics of an NBS/GPS Receiver," 13th Annual Precise Time and Time Interval (PTTI) Applications and Planning Meeting, Naval Research Laboratory, Washington, DC, December 1981.
- 23) Private Communication with Walt Harbour, OAO Corporation, August 1981.

TABLE I
TIME TRANSFER ERROR BUDGET

	PHASE I GPS SPECIFIED ONE SIGMA ERROR BUDGET ¹² (nanoseconds)	OCS SPECIFIED ONE SIGMA ERROR BUDGET (nanoseconds)
SV GROUP DELAY AND CLOCK	9 (for 2 hrs) 25.5-108 (for 24 hrs)	20*
SV EPHEMERIS	12 (for 24 hrs)	
IONOSPHERIC/ TROPOSPHERIC DELAY/MULTIPATH	5-40**	5-40**
RECEIVER NOISE (RAW/SMOOTHED)	6.3/1.0	6.3/1.0
PSEUDORANGE QUANTIZATION (RAW/SMOOTHED)	5.8/0.9	5.8/0.9
USER LOCATION ESTIMATION AND RECEIVER BIAS	5-15	5-15
TOTAL (RSS) (RAW/SMOOTHED)	(18-117)/(17-117)*** (18-52)/(17-51)****	(23-50)/(21-47)

* BETWEEN SUCCESSIVE UPLOADS¹³
 ** ELEVATION ANGLE, LATITUDE AND TIME OF DAY DEPENDENT
 *** RUBIDIUM FREQUENCY STANDARD IN SATELLITE
 **** CESIUM FREQUENCY STANDARD IN SATELLITE

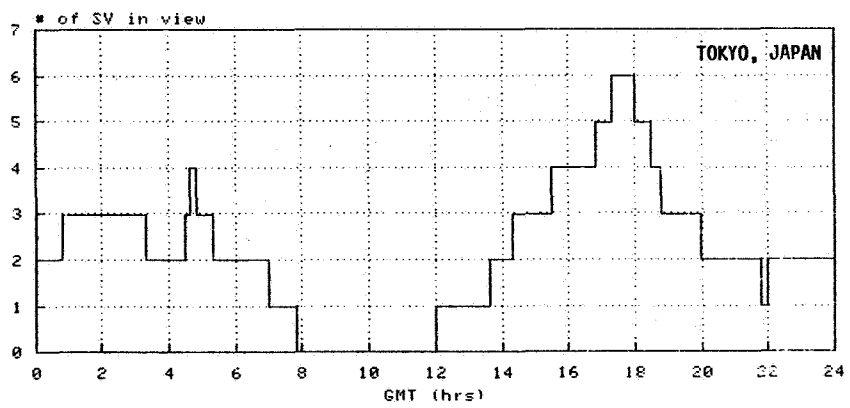
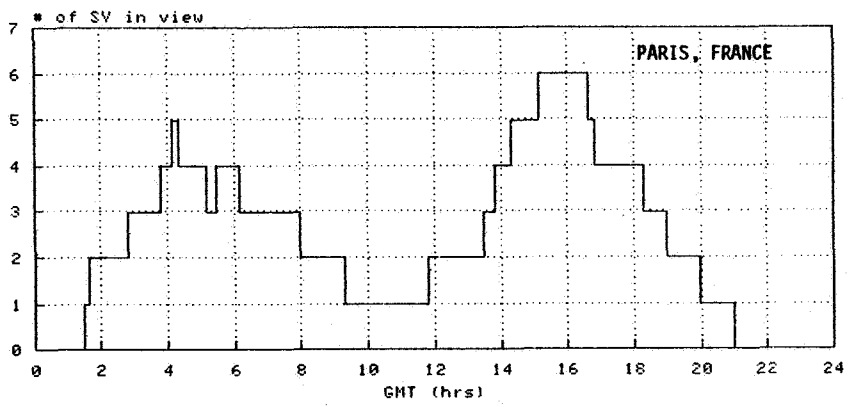
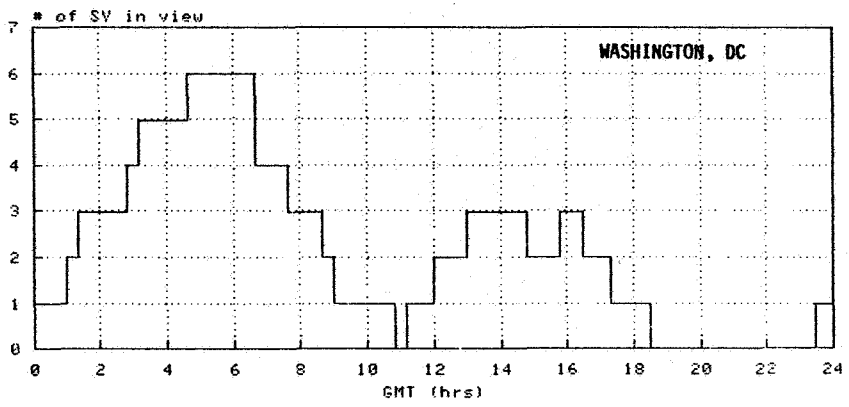

FIGURE 1 SIX SATELLITE COVERAGE

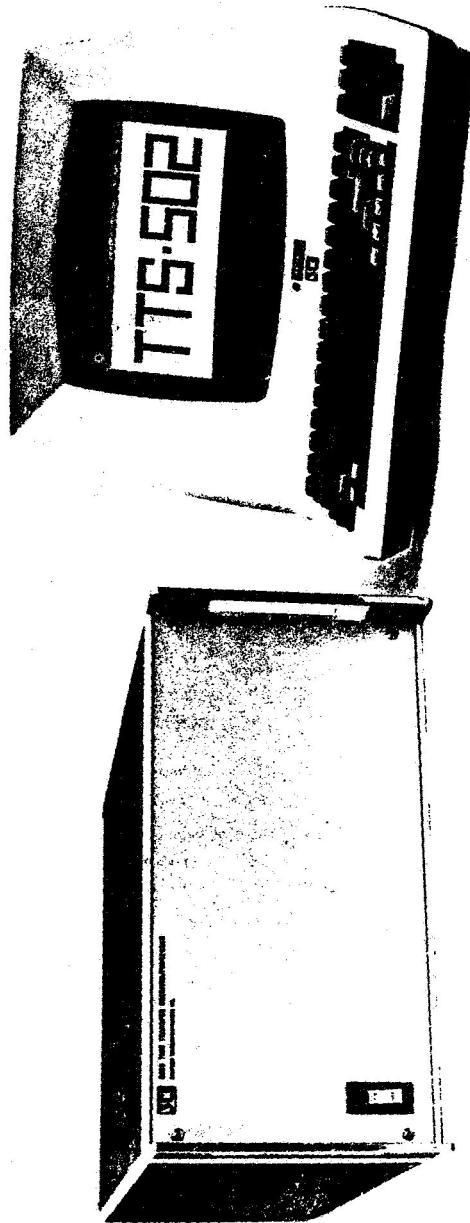
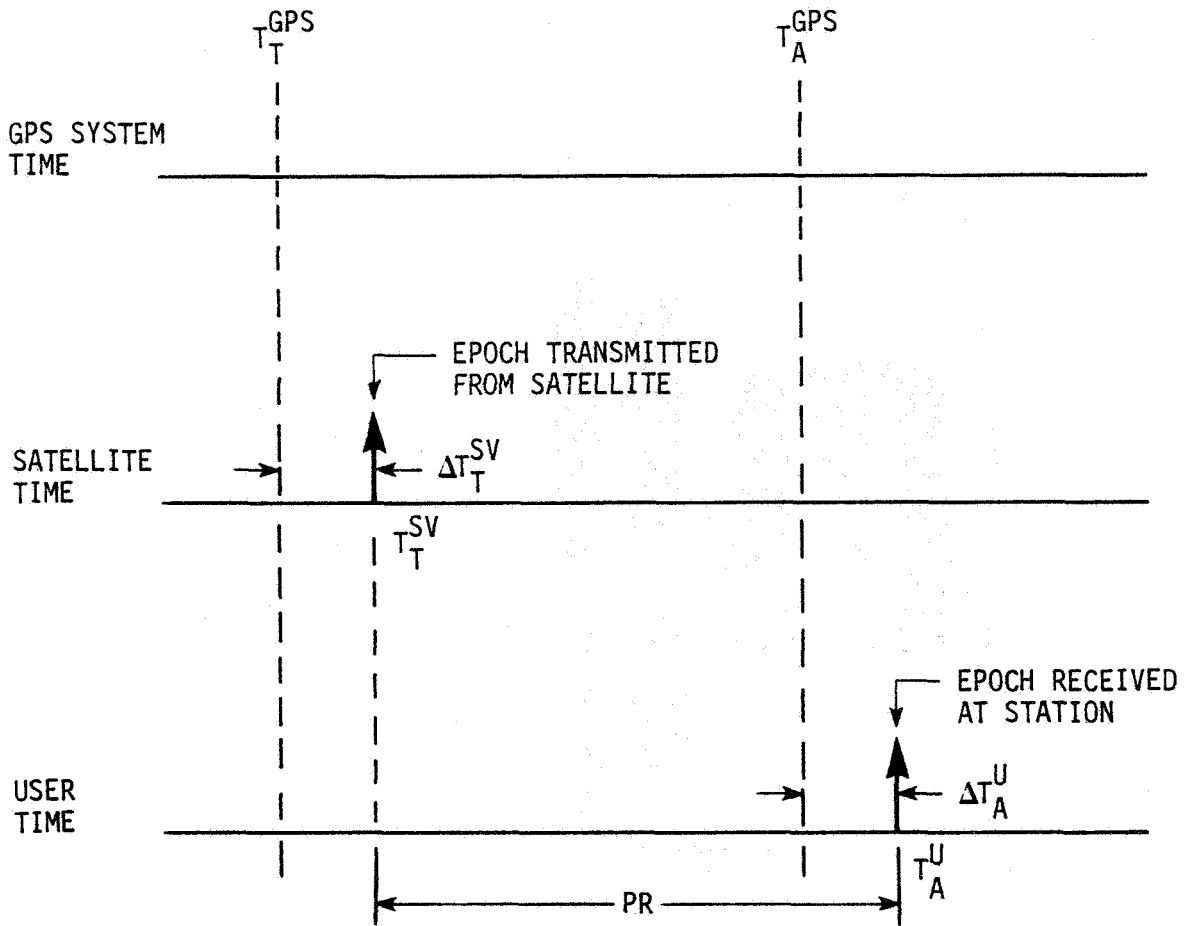

FIGURE 2 TTS-502 (ANTENNA AND PREAMPLIFIER NOT SHOWN)



- T_T^{SV} : SATELLITE TIME AT EPOCH TRANSMISSION
- T_T^{GPS} : GPS TIME AT EPOCH TRANSMISSION
- ΔT_T^{SV} : SATELLITE CLOCK ERROR AT EPOCH TRANSMISSION
- T_A^U : USER TIME AT EPOCH ARRIVAL
- T_A^{GPS} : GPS TIME AT EPOCH ARRIVAL
- ΔT_A^U : USER CLOCK ERROR AT EPOCH ARRIVAL
- PR = USER-MEASURED PSEUDORANGE
- $$= T_A^U - T_T^{SV} = T_A^{GPS} - T_T^{GPS} - \Delta T_T^{SV} + \Delta T_A^U$$

FIGURE 3 TIMING RELATIONSHIPS

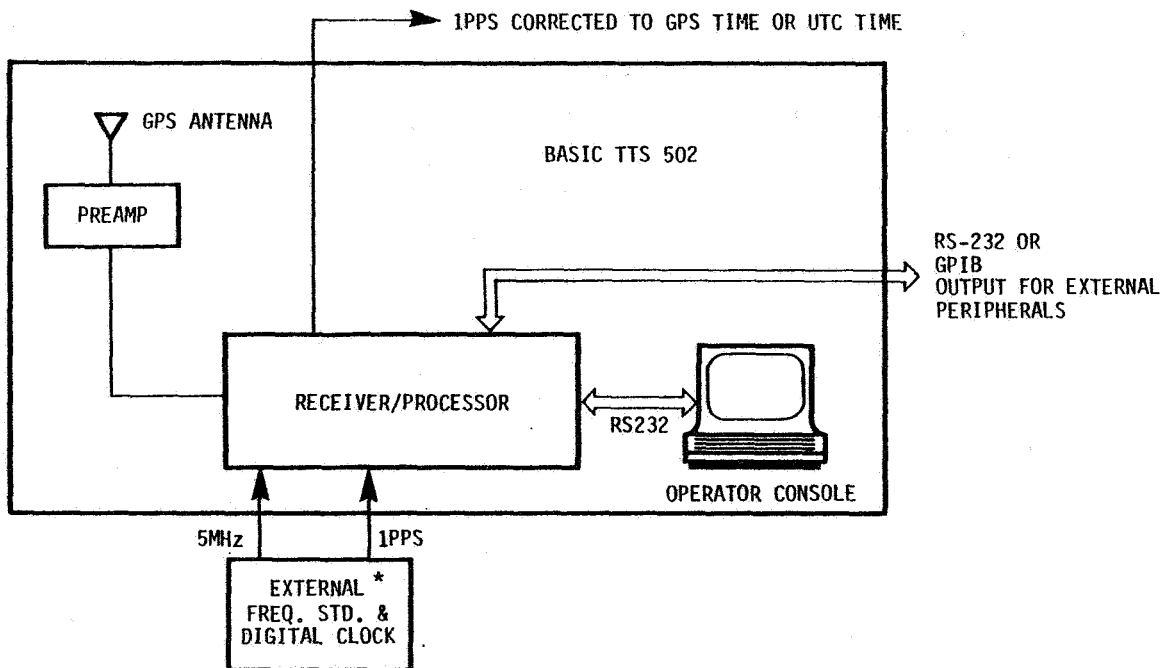

FIGURE 4 TIME TRANSFER SYSTEM 502

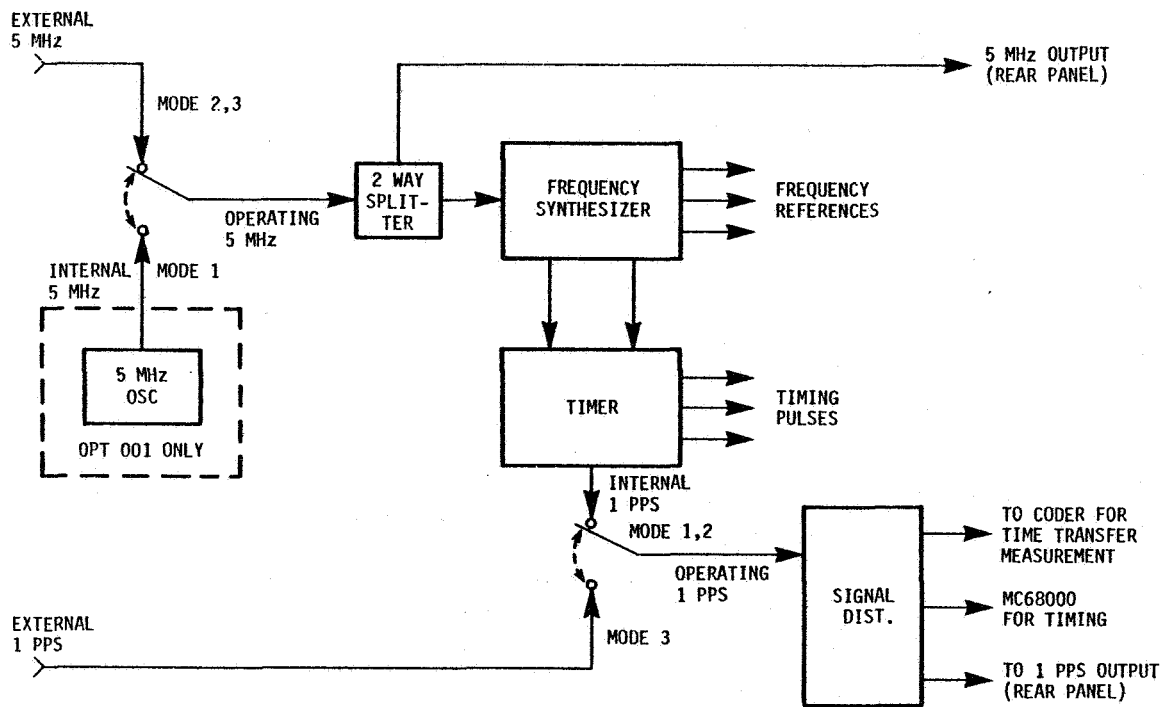

FIGURE 5 TTS-502 TIME SOURCE OPERATION MODES

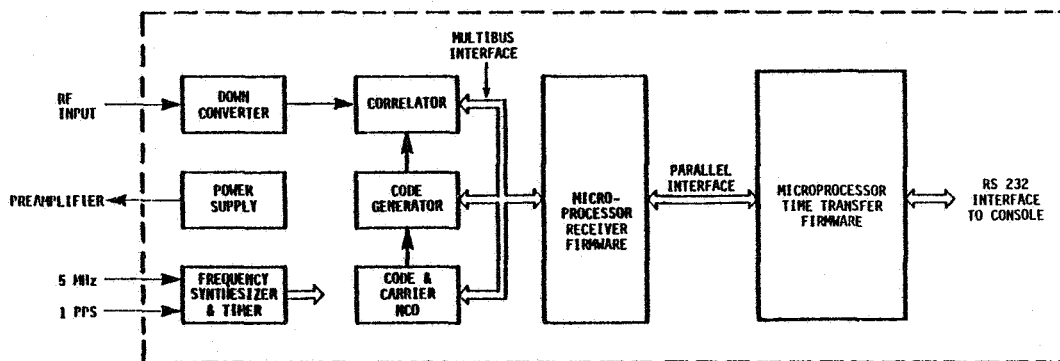

FIGURE 6 TIME TRANSFER RECEIVER/PROCESSOR MODEL 5026 BLOCK DIAGRAM

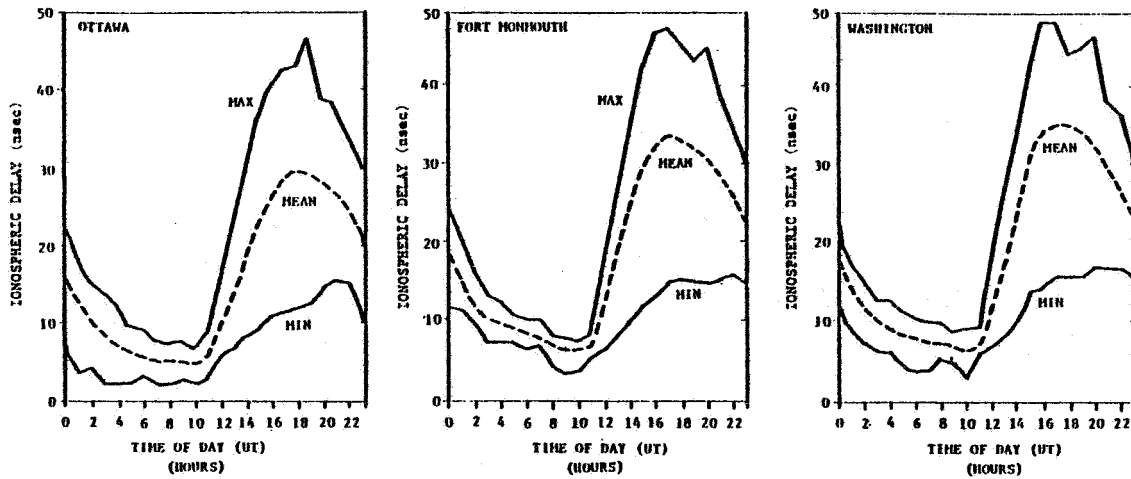

FIGURE 7 MEAN IONOSPHERIC DELAY AND ENVELOPE OF DELAY VARIATION VS. TIME OF DAY DURING -MARCH, 1958- SATELLITE AT ZENITH $f=1.6$ GHz (FROM REFERENCE 16)

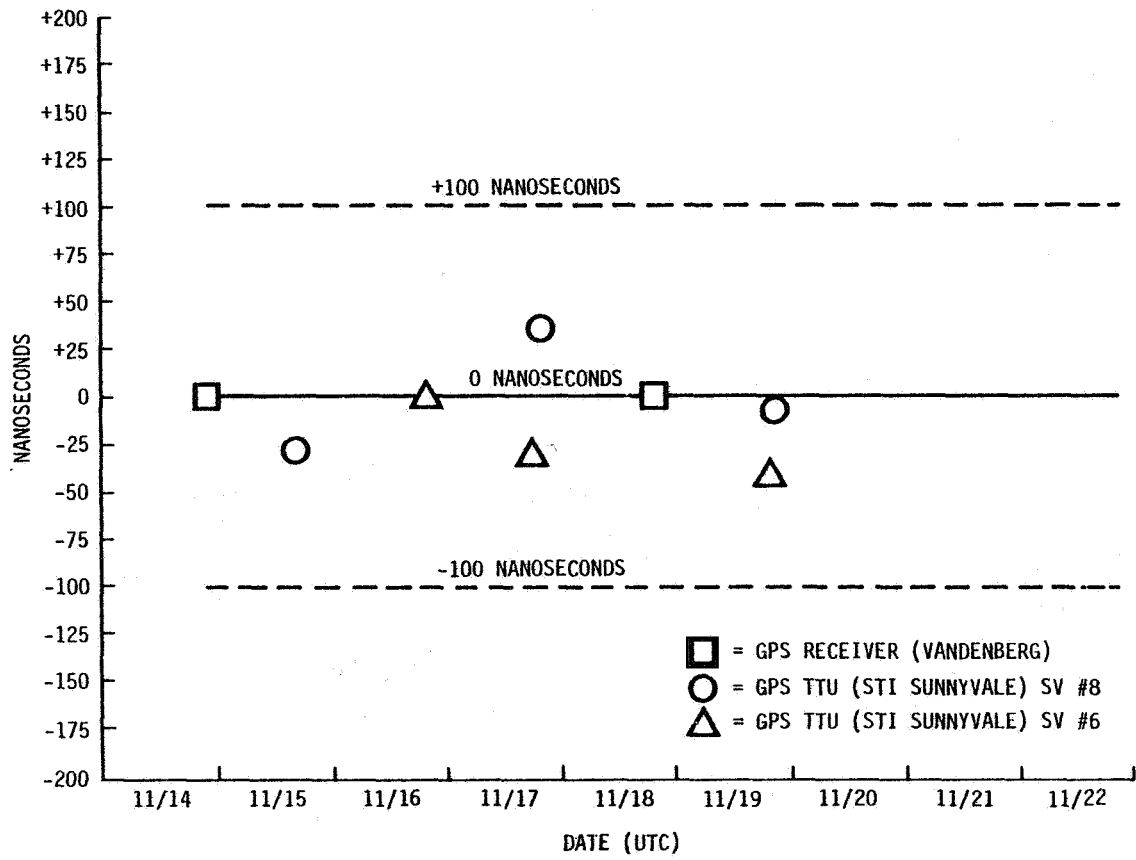

FIGURE 8 INITIAL TIME TRANSFER RESULTS

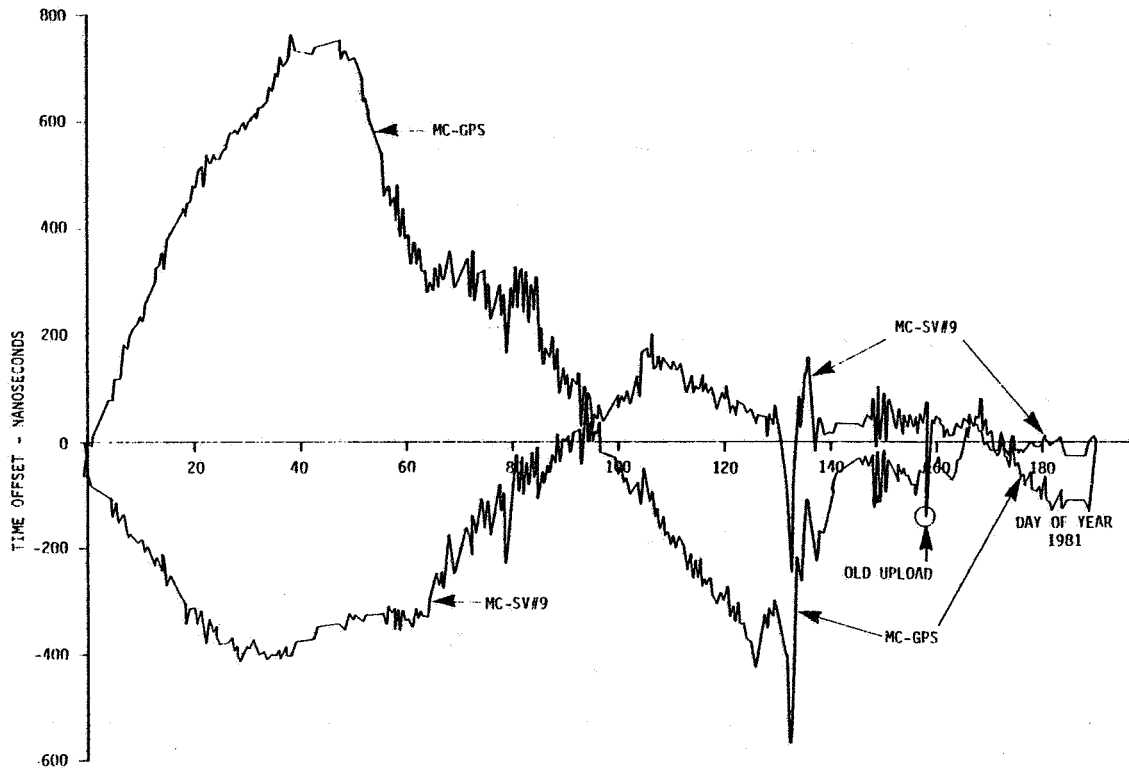

FIGURE 9 USNO TIME MONITORING RESULTS USING SV#9 FROM 1 JANUARY 1981 TO 11 JULY 1981

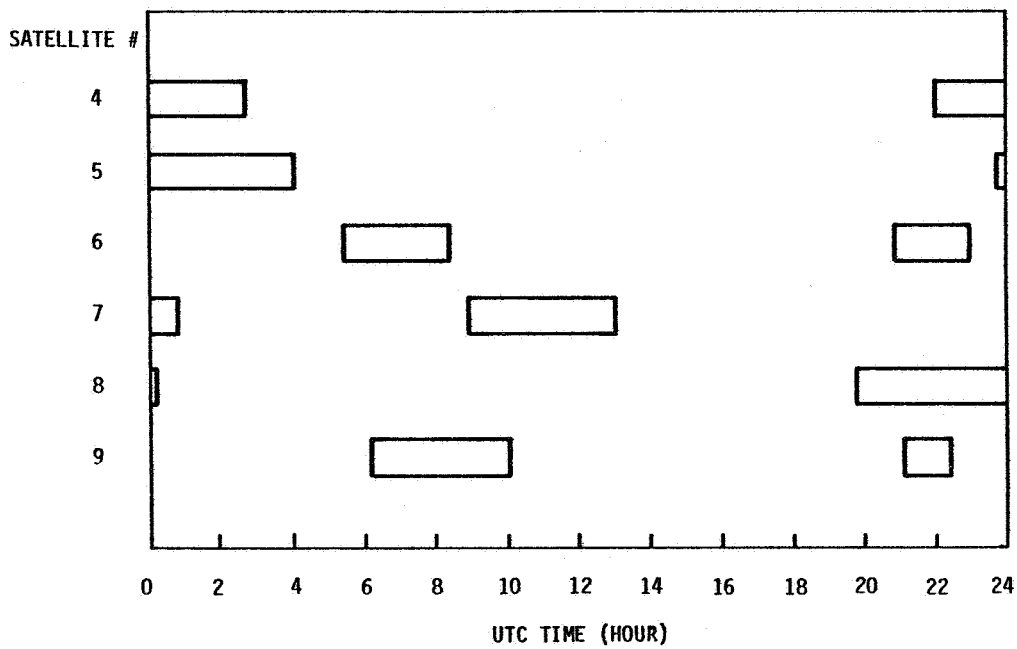

FIGURE 10 COMMON-VIEW TIME BETWEEN WASHINGTON,DC AND PARIS,FRANCE ON 2 OCT 1980