

TIME CODE DISSEMINATION EXPERIMENT VIA THE SIRIO-1
VHF TRANSPONDER⁽¹⁾

E. Detoma
Bendix Field Engineering Corporation, Columbia, Maryland

G. Gobbo
Telespazio, Roma

S. Leschiutta
Politecnico di Torino

V. Pettiti
Istituto Elettrotecnico Nazionale, Torino

ABSTRACT

The advantages of employing synchronous satellites for time dissemination are well known, both in terms of coverage and continuity of service over the covered area. Many synchronous telecommunications satellites carry onboard VHF transponders; these are mainly used as ranging transponders during the launch phases and as beacons or telemetry backup transmitters during the satellite operational life, in which the ranging capabilities of these transponders are seldom used. The aim of the experiment described in this paper was to test the possibility of using these VHF transponders, in their ranging configuration, as repeaters to disseminate time information over a wide area. The experiment, proposed by the Istituto Elettrotecnico Nazionale (Torino, Italy), was performed during the summer of 1980, with the cooperation of Telespazio S.p.A., and using the VHF transponder onboard the synchronous experimental telecommunications satellite SIRIO-1.

(1) The work was made possible by a grant from the Italian National Research Council/Italian National Space Plan.

PURPOSE OF THE EXPERIMENT

The aim of the experiment was to evaluate the possibility of disseminating a time code via the SIRIO-1 satellite, by using the onboard VHF repeater. The precision in the synchronization of remote clocks was expected to be of the order of 0.1 to 1 ms.

The main features of the proposed experiment can be briefly summarized as follows:

- 1) the RF carrier was in the VHF band, so that low cost receivers could be used and then a broader class of users could be served;
- 2) an already existing repeater, even if not designed specifically for communications could be utilized; the operation of this repeater was not intended to affect any other function of the spacecraft (both the SHF repeater and the VHF telemetry link were active during the time code dissemination via the VHF transponder).

Moreover, the rising interest about methods of time dissemination using satellites is fostered. The European Space Agency (ESA) is in the process of evaluating the possibility to insert the same time code used by the U.S. GOES satellites in the telemetry message transmitted by Meteosat. In addition, the dissemination of a narrow-band time code is possible also using an MDD (Meteorological Data Dissemination) channel of SIRIO-2. A similar implementation is planned by the Indian National Physical Laboratory; in this instance a 10 kHz channel via the INSAT satellite will be used for frequency and time dissemination.

A geostationary orbit is the optimum choice for time dissemination purposes, since the coverage of a single geostationary satellite is about one third of the Earth surface. For a user located within this area, the satellite is always visible; this way a service continuity is easily implemented.

However, small variations in the position of the satellite affect seriously the uncertainty of the time code dissemination, since the propagation delays are not constant.

Two orbital elements are primarily responsible for these variations: the inclination i of the orbital plane, that

causes a variation of $+i$ in the satellite declination over one day, and the orbit eccentricity e , on which the orbital velocity depends; this causes a periodic (period = 1 day) variation in the satellite hour angle.

In the time code dissemination the synchronous satellite acts usually as a repeater of the time signals transmitted by a ground station. Then, an onboard oscillator, a clock and related control equipment are not needed. Since almost all the equipment is on ground, the reliability of the service is very high; moreover, the ground located equipment can be easily serviced or substituted in case of failure. It is customary to refer to this mode of operation as a "one-way technique", since the signal travels from the ground station to the satellite and from the satellite to the users (fig.1).

Previous time code dissemination experiments or services are summarized in table I, along with the main specifications of each one.

THE VHF TRANSPONDER

We were particularly interested in using the onboard VHF transponder because it is seldom used during the operational lifetime of the satellite. The SIRIO-1 VHF transponder was used in the ranging mode only during the launch and the first months of operation of the satellite (August-December 1977). Afterwards, it was used only as a beacon for propagation experiments, as a backup telemetry link (the main link uses the SHF transponder) and as a commands receiver.

The repeater is basically a phase modulated (PM) transponder. In the ranging mode, several tones are transmitted to the satellite and from the satellite back to Earth.

By comparing the phase of the received tone with the transmitted signal, we get the range between the satellite and the ranging site. The baseband (video) bandwidth of the transponder in the ranging mode is about 20 kHz, that is the frequency of the highest tone employed.

The switching of the repeater in the ranging mode (normally it acts only as a telemetry transmitter and commands receiver)

is obtained by a "preset" command followed by the transmission of a 20 kHz holding-tone.

When the satellite receives this tone the onboard transponder is switched to the ranging mode, so that it acts as a "transparent" repeater. The holding tone must be received continuously to hold the transponder in the ranging mode, so that, in our experiment, the time code was simply added to the tone.

Under these conditions, since the time code and the holding tone are retransmitted by the satellite on two equally spaced ranging subcarriers (fig. 2), the telemetry transmission was not interrupted, but the telemetry carrier power is reduced.

So, in the ranging mode, it is possible to use the VHF transponder as an additional communication channel, and to obtain the time code dissemination without affecting the VHF telemetry link.

THE TIME SIGNAL

In the experiment we used the same IEN time code that is broadcasted over Italy by the National Broadcasting Company (ref. 1). This is a narrow-band time code (fig. 3), repeated every minute, starting at second 52. The duration of the code is 960 ms and it contains a complete date information, including hours, minutes, month, day of the month, day of the week and a flag indicating if the hours are referred to a daylight saving time; moreover, standard items such as start, stop and parity checking bits are added to the code.

This digital BCD code is transmitted by using an audio frequency shift keying (AFSK) modulation, whose bandwidth is compatible with the AM broadcast requirements, featuring a very narrow bandwidth; the two tones used are a 2 kHz tone to indicate a logical "0" and a 2.5 kHz tone to indicate a logical "1".

After the code, a train of six bursts of 1 kHz tone is transmitted, the duration of each burst being 100 ms, starting at seconds 54,55,56,57,58 and 00 of the following minute.

This provides an audio information easily recoverable by users that have not access to the special equipment for de-

coding the time code (ref. 2,3 and 4).

Because of the experimental nature of the tests and since the transmitting and receiving equipment was located at the same site so that the propagation delay was directly measurable, no information about the satellite position was added to the time code, the principal concern being the measure of the communication link capabilities with such a narrow-band time code.

Following tests performed in our laboratories to define the capabilities of the code alone, it has been shown (ref. 5) that a maximum precision between 1 and 10 μ s is possible in recovering the time information, with a good signal-to-noise ratio and by using the commercially available decoders.

EXPERIMENTAL SETUP AND RESULTS OF THE MEASUREMENTS

The transmitting and receiving equipment was located at the Fucino station, near Rome, which is operated by the Telespazio, the company in charge of space telecommunications in Italy.

The RF carriers are depicted in fig. 2 and in table II. Only one of the two ranging subcarriers was decoded, and since the transmitted power of the single subcarrier was very low, we had a very poor S/N. This could be improved by demodulating both subcarriers, but this operation was deferred to when the necessary equipment will become available.

The time signal TS(FUC) to be transmitted to the satellite (fig. 4) is locally generated by the time code generator AR1340 (fig. 5).

The time code TS(IEN), received via a ground microwave link from the IEN in Torino is used only as a reference to synchronize the station generator. The local 5 MHz time base is obtained by a Telespazio owned Rubidium clock. The reference 1 Hz and 0.1 Hz signals are obtained from this frequency by division.

The 20 kHz holding-tone is locally generated by synthesis from the 5 MHz standard frequency or from a separate crystal oscillator as a backup. When generated from the Rubidium fre-

quency, this holding tone can be used as a standard signal broadcasted along with the time code, allowing continuous phase or frequency comparisons and improving the resolution of the synchronization.

The code was transmitted once every ten seconds; the gating is obtained from the 0.1 Hz signal (fig. 4) generated by the local time base of the receiver RFM/C (fig. 6): this receiver/decoder is a commercially available unit.

The decoded output is a pulse every 10 seconds; such a pulse is generated when a time message is received and decoded. The decoded output pulses are fed to the start channel of the counter, while the stop channel is connected to the 1 Hz local time base.

Since the code is transmitted at 0 seconds in this local reference, it lasts 960 ms and the propagation delay is around 255-256 ms, then the start pulses are generated at about 215 ms of the minute following the transmission minute.

The counter measurements ϵ_i are then the complement to 1 second of the reception time and their value is about 785 ms on the average.

Every measurement run consisted of 60 measurements ϵ_i ; the data were then stored on magnetic tape for subsequent processing. The average value of each group of data is then computed as the arithmetic mean ϵ , with an associated standard deviation σ .

The evaluation of ϵ and σ is carried out by applying a 3-sigma width filter; that is any measured value ϵ_i is rejected if the residual $|\epsilon_i - \epsilon| > 3\sigma$; if any ϵ_i has been rejected, a new ϵ and σ are evaluated using the remaining data. This procedure is repeated until no more data are rejected.

Assuming a normal distribution of the data, the one-sided estimated error $|\delta_\epsilon|$ in the determination of ϵ is given, with the 99.5% confidence, as:

$$|\delta_\epsilon| = \frac{\sigma \cdot t_{0.995}}{\sqrt{n}}$$

where n is the number of available data and t is the Student distribution.

Some results are summarized in table III and in fig. 7; the magnitude of σ_{ϵ} , with $n \approx 60$ data, ranges usually between 0.4 and 0.6 ms.

CONCLUSIONS

After the experiment and looking at the results, we can not only recognize the difficulties but also the possibility of using the satellite VHF transponder for time code dissemination. In spite of the very difficult conditions of the radio link, we were always able to obtain the desired accuracy (less than 1 ms).

However, in order to test the code capabilities by using a better channel, we performed a series of measurements via the satellite SHF transponder; the results of these tests are summarized in appendix A.

We would like to thank all the personnel at the Telespazio ground stations for their support and Messrs. E. Angelotti, F. Cordara, V. Marchisio and L. Pietrelli who actually carried out the measurements at the sites.

APPENDIX A - SHF TESTS

The measurements were carried out in September 1980 at the Lario ground station in North Italy, by using the SHF transponder onboard the satellite, which provides a better communication channel than the VHF transponder. The uplink frequency was 17.10 GHz, the downlink frequency was 11.52 GHz. The modulation now was FM and the signal-to-noise ratio was larger than 30 dB. The measurements were carried out with the same equipment used at Fucino and shown in fig. 4. Typical results are given in fig. 8 and table IV, showing the improvement in δ_{ξ} versus the VHF data: now δ_{ξ} was down to 10-20 μ s. This has been proven to be the limit of the present decoding equipment, so the SHF channel appears to be really noise-free.

In fig. 8 is also easily noticeable the slow variation in the propagation delay due to the satellite approaching the station.

REFERENCES

- 1 - S. Leschiutta, V. Pettiti, E. Detoma - Time coded distribution via broadcasting stations, Proc. of the 11th PTTI Meeting (NASA/DoD - Washington D.C. - December 1979).
- 2 - F. Cordara - Nuovo segnale orario codificato, Elettronica e Telecomunicazioni, n. 6 (1979), pp. 241-243.
- 3 - F. Cordara, V. Pettiti - Codici orari radiodiffusi per sistemi automatici di acquisizione dati, 27° Congresso Scientifico Internazionale per l'Elettronica (Roma, marzo 1980).
- 4 - E. Angelotti, S. Leschiutta - Segnali di tempo e codici orari radiodiffusi, L'Elettrotecnica, vol. LXVII, n. 5 (maggio 1980), pp. 449-453.
- 5 - V. Pettiti - Indagine sulla fluttuazione di decodifica del codice di tempo, Rapporto Interno IEN n. RI-2/80S (marzo 1980).

Table I - Time dissemination via satellites
Experiments and services

Satellite	Country	Year	Mode of operation	Carrier frequency	Accuracy
Transit NNSS	U.S.A.	1967-1981	Onboard clock	VHF - UHF	1-10 μ s
ATS-3	U.S.A.	1973-1974	One-way	VHF	20-100 μ s
GOES	U.S.A.	1976-1981	One-way	UHF	10-20 μ s
GPS	U.S.A.	1979-1981	Onboard clock	Microwave	10-100 ns
SIRIO-1	Italy	1980	One-way	VHF SHF	1 ms 10-20 μ s

Table II - Main features of the RF link

1. - RF characteristics

- * Uplink frequency: 148.260 MHz
- * Downlink frequency (carrier): 136.140 MHz
- * Ranging subcarriers frequency: ± 775 kHz
(from the carrier)
- * Modulation: phase modulation (PM)

2. - Equipment setup

- * Diversity polarization combiner reception
- * Diversity combiner: Electrac mod. 215C
- * Phase lock demodulators: Electrac mod. 215

3. - Measurement conditions

- * Tracking bandwidth: 100 Hz
- * Demodulator output bandwidth: 1500 Hz
- * Modulation phase shift:
 - holding-tone only 0.7 rad
 - complete signal 1.5 rad_{max}
 - (holding-tone + time code)
- * Signal-to-noise ratio: $2 < S/N < 5$ dB

SIRIO-1 TIME CODE DISSEMINATION EXPERIMENT

FILTERED DATA
(3-sigma filter width)

Table III - Sample of VHF results

Elapsed time (min.)	ϵ (ms)	σ (ms)	Number of measurements	$ \sigma\epsilon $ (ms) [$t_{0.995}$]
0	787.042	1.149	59	0.432
10	786.913	1.216	59	0.458
20	787.248	1.070	60	0.403
30	787.084	1.725	60	0.649
40	787.331	1.182	59	0.445
50	786.597	1.717	60	0.646
60	787.094	1.262	60	0.475

Date: 21 Aug. 80
 Elapsed time: from 1200 GMT
 Station: Fucino
 Link: VHF

SIRIO-1 TIME CODE DISSEMINATION EXPERIMENT

FILTERED DATA
(3-sigma filter width)

Table IV - Sample of SHF results

Elapsed time (min.)	ϵ (ms)	σ (μ s)	Number of measurements	$ \delta\epsilon $ (μ s) [$t_{0.995}$]
0	784.042	30.7	60	11.7
12	784.058	28.0	60	10.6
22	784.057	29.3	60	11.1
32	784.061	29.6	60	11.2
43	784.062	29.4	60	11.2
53	784.068	28.5	60	10.8
64	784.072	28.9	60	11.0
75	784.073	29.1	60	11.1
85	784.077	29.1	60	11.1
96	784.082	32.7	60	12.4

Date: 10 Sep. 80
Elapsed time: from 1405 GMT
Station: Lario
Link: SHF

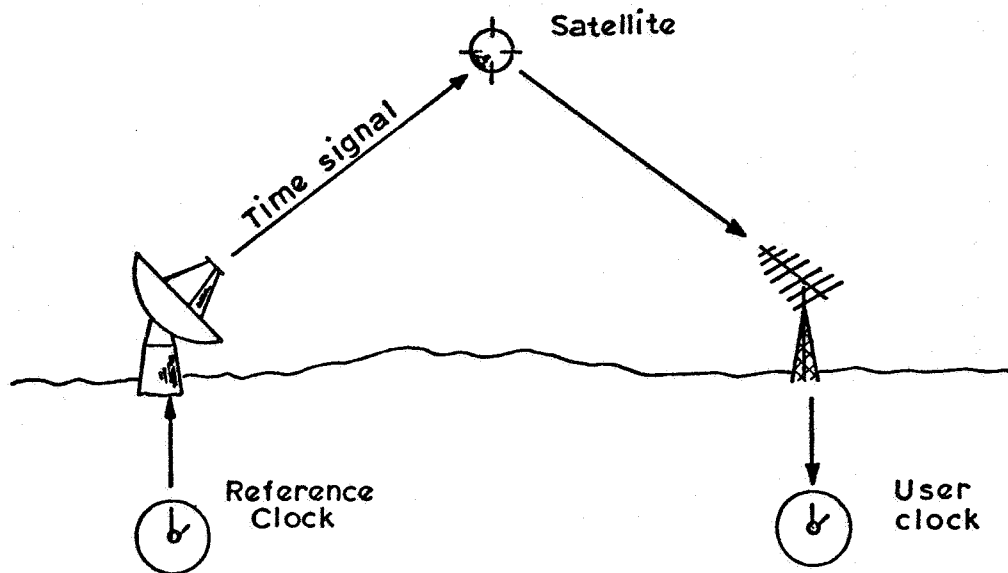
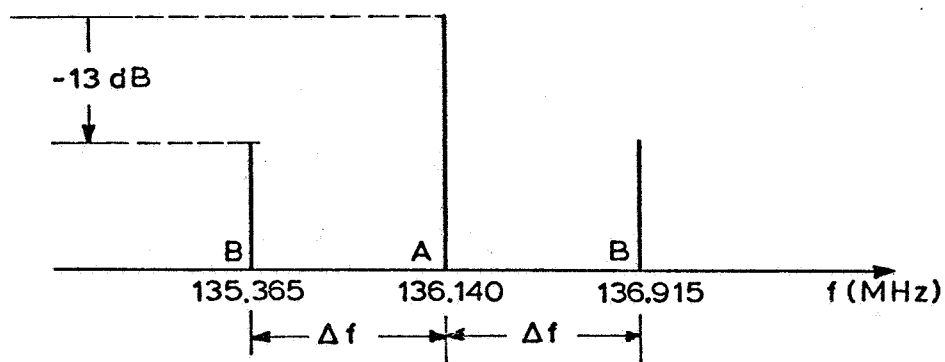
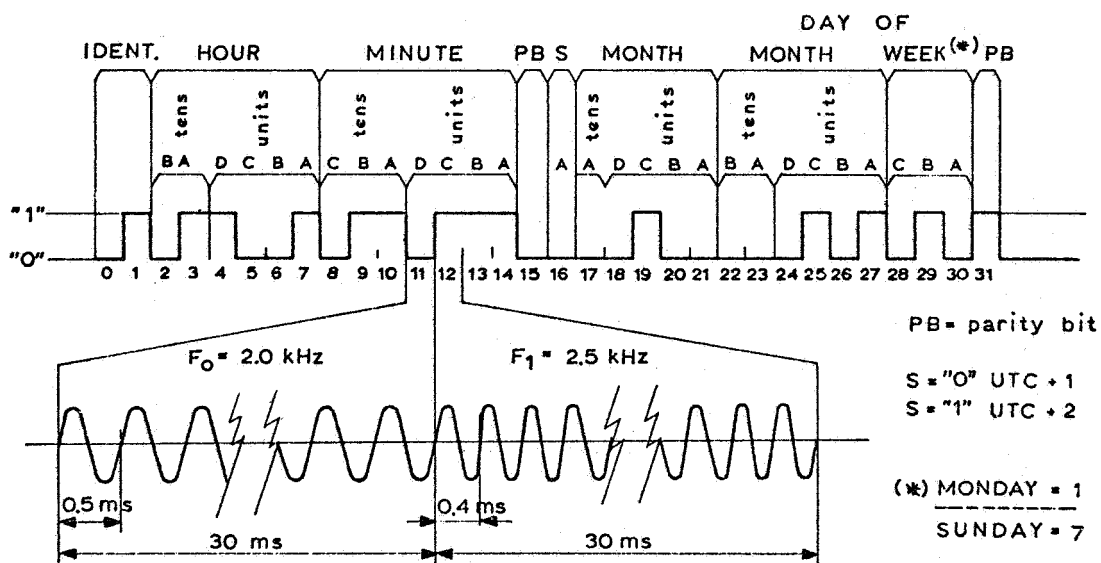
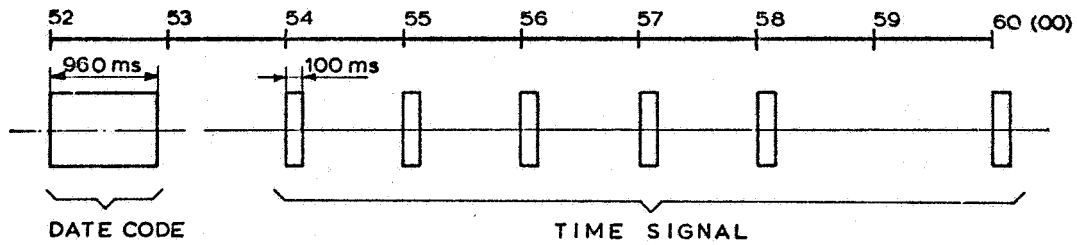

Fig.1 - One-way time dissemination via satellite



A = telemetry carrier at 136.140 MHz
 B = ranging subcarriers: $\Delta f = \pm 775$ kHz

Fig.2 - VHF spectrum transmitted by the satellite



DATE CODE AND DETAILS OF THE FSK MODULATION; THE DATE TRANSMITTED IS TUESDAY 5 APRIL, 19 HOURS 37 MINUTES, UTC+1

Fig.3 - Coded time signal broadcasted by the National Radio Company

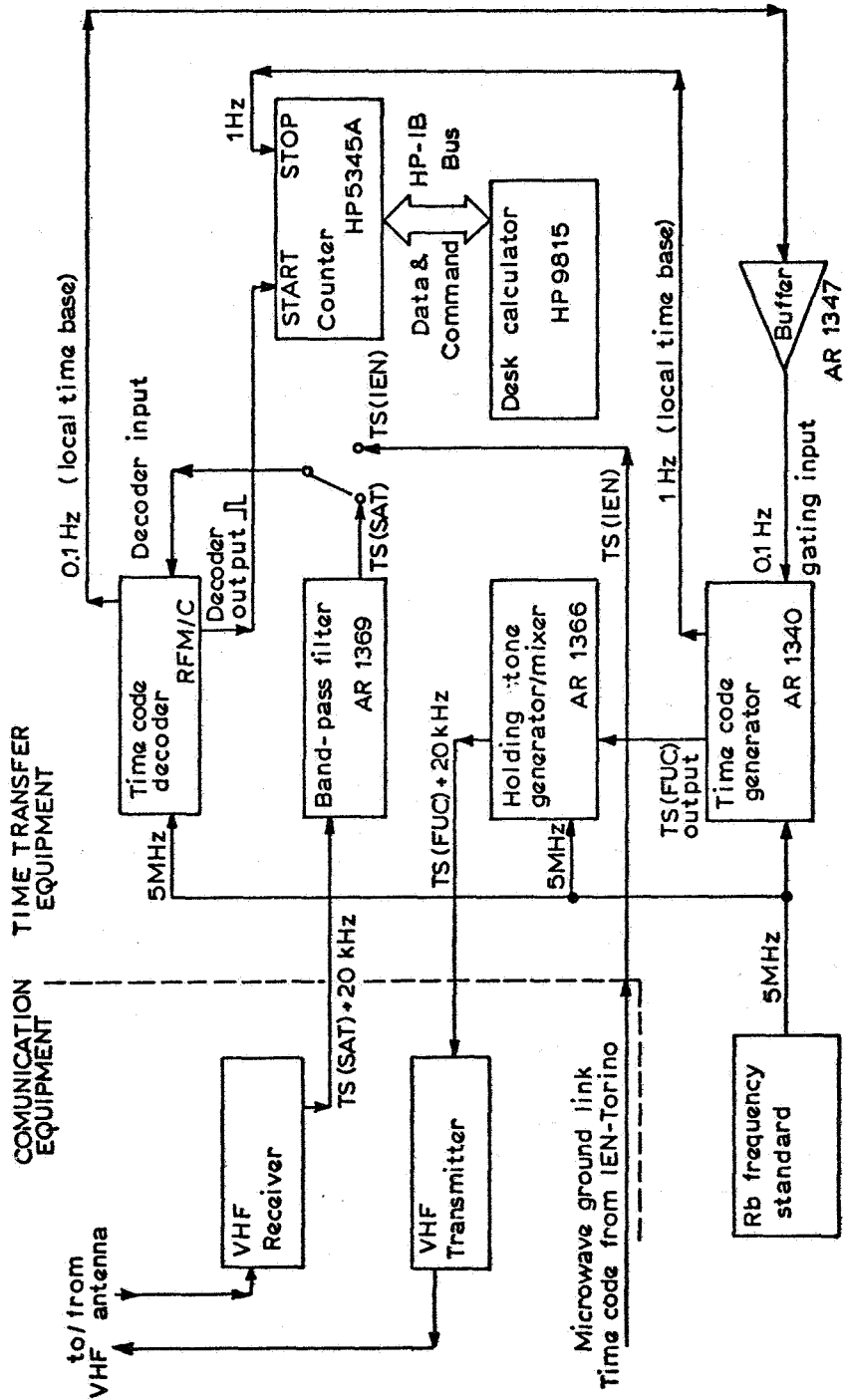

TS = Time signal

Fig.4 - Experimental set-up (Fucino ground station)

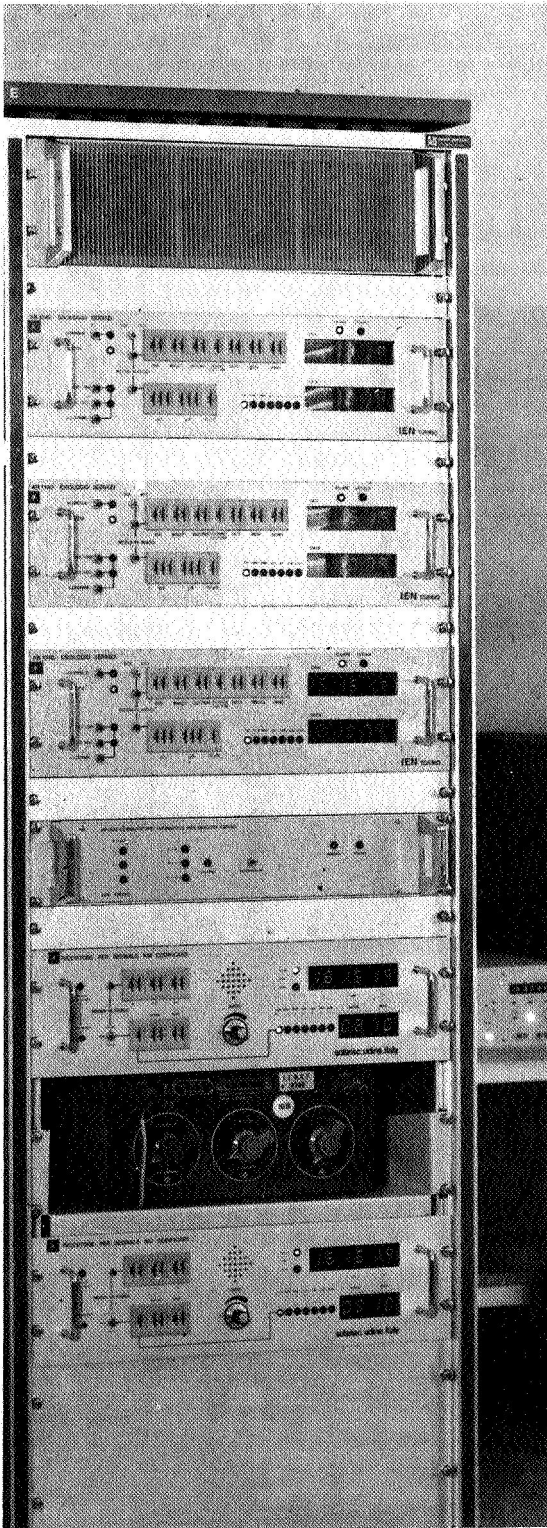

←Fig. 5 - The time code generator AR 1340

←Fig. 6 - The time signal receiver/decoder RFM/C

SIRIO-1 TIME CODE DISSEMINATION
EXPERIMENT

Fig.7 - VHF DATA SAMPLE

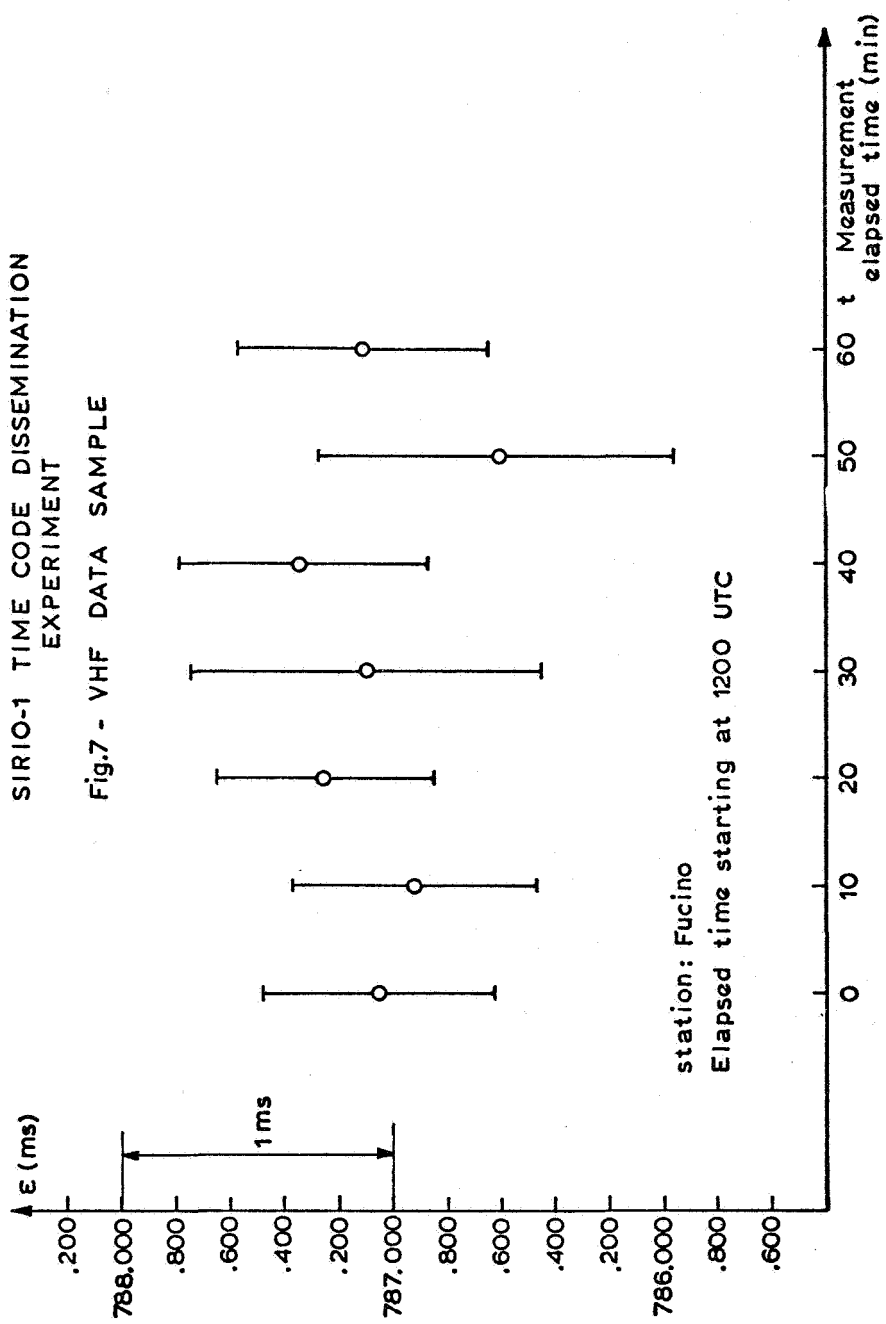

SIRIO-1 CODE DISSEMINATION EXPERIMENT
 Fig 8-SHF DATA SAMPLE

