

NASA CR-166,377

NASA CONTRACTOR REPORT 166377

NASA-CR-166377
19820022524

Studies of New Perfluoroether
Elastomeric Sealants

D. I. Basiulis
D. P. Salisbury
Hughes Aircraft Co.

NOT TO BE REPRODUCED

LIBRARY COPY

SEP 1982

CONTRACT NAS2-10334
September 1981

LANGLEY RESEARCH CENTER
LIBRARY NASA
HAMPTON, VIRGINIA

NASA



NF02635

NASA CONTRACTOR REPORT 166377

Studies of New Perfluoroether
Elastomeric Sealants

D. I. Basiulis
D. P. Salisbury

Hughes Aircraft Co.
Culver City, CA

Prepared for
Ames Research Center
under Contract NAS2-10334

NASA

National Aeronautics and
Space Administration

Ames Research Center
Moffett Field, California 94035

N82-30400#

This Page Intentionally Left Blank

PREFACE

This technical report was prepared by Hughes Aircraft Company, Culver City, California, under NASA Contract NAS 2-10334. The contract was administered under the direction of the NASA-Ames Research Center at Moffett Field, with Dr. Robert W. Rosser as Project Manager.

This report covers the second year's work performed from 1 October 1980 to 26 September 1981.

The Hughes program manager from 1 October until 27 February 1981 was ~~Mr.~~ D. Patrick Salisbury. From 27 February 1981 until 26 September 1981, the program manager was ~~Mr.~~ Danute I. Basiulis, Head of the Formulations Group in the Materials Technology Department.

Technical assistance was provided by Mr. Dwight R. Waterman in the Formulations Group. Thermal analyses were performed by Ms. Phyllis J. Rourke and Ms. Janie H. Mathis. Mechanical testing was performed by Mr. William J. Kelleghan and Mr. Robert R. Muego. Dr. Arthur B. Naselow, Dr. Abraham Landis, Mr. Robert W. Seibold and Mr. Robert E. Mazzolini served as internal consultants.

This Page Intentionally Left Blank

CONTENTS

1.0	SUMMARY AND CONCLUSIONS	1
2.0	INTRODUCTION	3
3.0	CHANNEL SEALANT	7
3.1	Polymerization	7
3.2	Formulation	10
3.3	Physical Properties	13
3.4	Mechanical Testing	16
3.4.1	Pressure Rupture Resistance	16
3.4.2	Adhesion	19
3.4.3	Low Temperature Flexibility	19
3.5	Sealing Efficiency	21
3.6	Fuel and Corrosion Resistance	23
3.6.1	Fuel Resistance	23
3.6.2	Corrosion Resistance	23
3.7	Thermal Evaluation	24
3.8	Processability	31
4.0	FILLETING SEALANT	33
4.1	Polymerization	33
4.2	Formulation	34
4.3	Physical Properties	34
4.4	Mechanical Testing	36
4.4.1	Low Temperature Flexibility	36
4.4.2	Stress Corrosion	37
4.4.3	Adhesion	38
4.4.4	Tensile Strength and Elongation	44
4.4.5	Dynamic Mechanical Behavior	46
4.4.6	Compression Set	47

CONTENTS (Continued)

4.5	Fuel Resistance	49
4.6	Thermal Evaluation	51
4.7	Other Applications	55
4.7.1	Molding of O-Rings	55
4.7.2	Foam	55
4.7.3	Rubber Toughened Polyimides	55
5.0	PRELIMINARY EVALUATION OF TRIAZINE POLYMER AS SEALANT	59
5.1	Polymerization	59
5.2	Formulation	59
5.3	Thermal Evaluation	60
6.0	RECOMMENDATIONS FOR FUTURE WORK	65
7.0	REFERENCES	67
APPENDIX		69

LIST OF ILLUSTRATIONS

Figure		Page
1	IR of EDAF Diamidoxime Prepolymer	9
2	IR of EDAF Dinitrile Cross-Linker	9
3	IR of Channel Sealant at 154°C (310°F)	10
4	Isothermal TGAs	11
5	Rubber Micromill	14
6	Dry Box for Asbestos Formulation with Two-Roll Micromill	14
7	Pressure Rupture Test Fixture	17
8	Pressure Rupture Blowout Test Specimens	18
9	Low Temperature Flexibility Test Fixture	21
10	Gap Sealing Efficiency Test Fixture	22
11	TGA of Q-A	25
12	Isothermal TGA of Q-A after 13 Hours at 177°C (350°F) . .	25
13	TGAs of Channel Sealant Polymers	26
14	Isothermal TGA of Channel Sealant Polymer QB-3	28
15	TGA of Formulation 140	28
16	Formulation 165	28
17	Formulation 170	29
18	TGA of Formulation 163	29
19	TGA of Formulation 164	30
20	Thermal Extrusion Test Fixture	31
21	Viscosity Versus Shear Rate at Various Temperatures . . .	32
22	Shear Stress - Shear Rate Relationship at Various Temperatures	32
23	Stress Corrosion Fixture	37

LIST OF ILLUSTRATIONS (Continued)

Figure		Page
24	Dynamic Mechanical Behavior of Formulation 154	47
25	TGAs for J-Series Polymers	52
26	Isothermal TGAs for Formulations Used in Thermal Evaluation	53
27	Isothermal TGA of Formulation 148	54
28	Thermomechanical Analysis of Formulation 148	54
29	TGA of Uncured Triazine Polymer, CH 327	60
30	TGA of Triazine Prepolymer CH 327	61
31	TGA of Formulation 168	62
32	TGA of Formulated Triazine Polymer CH 204.2	62
33	Isothermal TGA of Formulated Triazine Polymer CH 204.2	63
34	TGA of Formulation 171	64
35	Isothermal TGA of Formulation 171	64

LIST OF TABLES

Table		Page
1	Fillers and Additives Used During the Study	12
2	Channel Sealant Formulations	13
3	Physical Properties of Formulation 165	16
4	Resistance to Pressure Rupture Testing, Formulation 140 .	18
5	Adhesion in Peel Per MIL-S-8802D, Formulation 165 and 170	20
6	Gap Sealing Efficiency of Formulation 165	23
7	Thermal Analysis Summary of Channel Sealant Polymers . .	27
8	Thermal Analysis Summary of Channel Sealant Formulations	30
9	Filleting Sealant Formulations	35
10	Physical Properties of Filleting Sealant	36
11	Stress Corrosion Test on Titanium	38
12	Adhesion in Peel Per MIL-S-8802D of Various Formulations to Aluminum Prior to Immersion	39
13	Adhesion in Peel per MIL-S-8802D of Various Formulations to Titanium	41
14	Adhesion in Peel per MIL-S-8802D of Various Formulations After Fuel Immersion	42
15	Lap Shear Strength of Formulation 128	44
16	Tensile Strength and Elongation per MIL-S-8802D of Various Formulation After Fuel Aging	45
17	Formulation Composition for Compression Set	48
18	Compression Set of Filleting Sealant Formulations . . .	48
19	Percent Compression Set of Formula 126 in Comparison with Other Elastomer Materials as a Function of Temperature	49

LIST OF TABLES (Continued)

Table		Page
20	Solvent Resistance of Formula 103	50
21	Solvent Resistance of Viton	51
22	Fuel Resistance of Formulation 166	51
23	Triazine Polymer Formulations	63

1.0 SUMMARY AND CONCLUSIONS

Channel and filleting sealants were developed successfully from cyano- and diamidoxime-terminated perfluoroalkyleneether prepolymers that were supplied by NASA. The prepolymers were polymerized, formulated and tested. The polymers and/or formulations therefrom were evaluated as to their physical, mechanical and chemical properties (i.e., specific gravity, hardness, nonvolatile content, corrosion resistance, stress corrosion, pressure rupture resistance, low temperature flexibility, gap sealing efficiency, tensile strength and elongation, dynamic mechanical behavior, compression set, fuel resistance, thermal properties and processability). Other applications of the formulated polymers and incorporation of the basic prepolymers into other polymeric systems were investigated. A cyano-terminated perfluoroalkylene-oxide triazine was formulated and partially evaluated.

The channel sealant in its present formulation has excellent pressure rupture resistance and surpasses present MIL specifications before and after fuel and heat aging. The sealant remains soft and pliable. No hardening was evident even after long term exposure to fuel. The fuel resistance of this polymer is excellent with very little volume change and no weight change, even after exposure beyond MIL specification requirements at elevated temperatures. Gap sealing efficiency at the 5 mil requirement was very good; however leakage developed at 10 mils. Low temperature flexibility was also acceptable. Peel adhesion samples of the channel sealant, when subjected to long term fuel immersion at elevated temperatures and salt water immersion, showed variations from polymer batch to polymer batch. The behavior of the channel sealant polymer under the most severe test (3 percent salt water) indicates a need to further study the polymerization of the starting materials with regard to cross-link density and extent of cure. The specific gravity of

the channel sealant is 1.7 to 1.8. The formulation surpasses the MIL specification nonvolatiles content requirement. The channel sealant is easily processable even at very low shear rates and, therefore, application should present no problems.

X
X
X
The filleting sealant shows excellent resistance to fuel and other solvents and is much more resistant than Viton. The present formulation shows no corrosive effect on the surface of titanium in long term testing at 288°C(550°F). The sealant has good adhesion to aluminum and titanium. No deterioration of adhesive strength resulting from elevated temperature fuel aging was noted. Lap shear strength and tensile strength surpass MIL specification requirements. The tensile strength and elongation of the sealant indicate a lightly cross-linked system with a Tg of -30°C. The compression set of this formulation is similar to that of commercially available neoprene and nitrile-based materials, but is not as good as other fluoro-elastomers. The thermal stability by thermogravimetric analysis is good, but minor variations have been noted from polymer batch to polymer batch. The filleting sealant formulation was used to mold O-rings, which were of good integrity.

A triazine polymer based sealant was formulated as a filleting sealant with indication of good thermal stability and fuel resistance.

Materials and process specifications on the channel and filleting sealants were prepared.

2.0 INTRODUCTION

Satisfactory sealing of irregularly-shaped riveted, bolted and/or spot-welded wing and fuselage cavities for use as fuel tanks has been a problem since these assemblies were first proposed for aircraft use. The original elastomeric sealant materials, used as filleting and faying surface seals and later channel sealant materials, had to have as their major characteristics resistance to deterioration by fuel, good adhesion, permanent flexibility and resistance to vibration and thermal and mechanical stresses at temperatures from -54° to $+71^{\circ}\text{C}$. With the advent of higher speed and supersonic aircraft, the temperature requirements have increased from 71°C to as high as 177°C (and 315°C projected) with a corresponding increase in the stresses placed on the sealant materials.

The increased stresses to which the sealants are subjected in the faster flying, hotter aircraft are both physical and chemical in nature. For example, at the higher temperatures, the sealants expand more, thus placing higher adhesive and cohesive stresses on the sealants and the sealant-to-metal bonds. The tendency for depolymerization or, conversely, additional cross-linking (stiffening) is increased, which in either case could lead to sealant failure. The rate of chemical reaction, either with fuel, fuel additives or with absorbed water, is considerably increased. Even the vibration rates and the "g" forces are increased, leading to mechanical adhesive or cohesive failures.

Because of these new conditions, new elastomeric polymers had to be developed that have the requisite mechanical, physical and chemical characteristics to resist the new conditions. Other very desirable requirements for these new sealant materials are the ability to be used as faying or filleting seals in a cured state and as channel sealants in an uncured or semicured

state. The material should be applicable by normal methods of brushing, spatula spreading, and/or gun injection.

Because of their known high temperature and excellent chemical resistance properties, the perfluoroether polymers were proposed as the matrix material in a formulation study to develop the next generation of fuel tank sealants. In addition, it was anticipated that these polymers, with formulation and curing mechanism modifications, also might be suitable for other aerospace applications, such as O-rings, gaskets and similar cured elastomeric seals.

Prepolymers of these perfluoroether materials, developed by NASA, were evaluated under this program. These prepolymers are cyano- and diamidoxime-terminated perfluoroalkyleneethers, which polymerize to the oxadiazole system, and a more recent cyano-terminated perfluoroalkylenetriazine, which yields a cross-linked homopolymer. These materials, when fully cured, yielded the thermally and hydrolytically ^{oxidatively} stable elastomeric materials that were used as the base polymers in this study.

The purpose of the program was to fully cure the prepolymers supplied by NASA and to compound them with required fillers, stabilizers, and other additives to result in optimum formulations for production of curing type faying and filleting fuel tank sealants and possibly O-rings and gaskets. Also the investigations included development of lower molecular weight channel type sealants. The formulation efforts included characterization studies to determine the physical, mechanical and chemical properties of the final materials, so that materials and processing specifications could be produced.

During the first year of this program (Ref. 1), an investigation was conducted to determine the types and amounts of compounding ingredients that had to be combined with NASA-furnished perfluoroether polymers and curing agents to produce a processable non-curing channel sealant system and elastomeric faying and filleting sealant systems. Physical properties such as adhesion, viscosity, thixotropy, moisture resistance, corrosivity, and thermal aging were studied, and basic characterization data were generated through the use of microgram and gram quantities of the base polymeric material.

This report is a summary of the progress during the second year of effort on this program. During this phase of the program, fillers and additives were selected and formulations developed for the channel and filleting sealants.

The sealants, based on the perfluoroalkyleneetheroxadiazole system, were evaluated and characterized as to rheological behavior, curing characteristics and mechanical, physical and chemical properties. Tests were conducted in typical aircraft chemical and thermal environments. Areas of new potential applications of the polymer were investigated. A sealant based on a triazine polymer was also formulated and partially evaluated. Materials and process specifications are provided in the Appendix.

This Page Intentionally Left Blank

3.0 CHANNEL SEALANT

A channel sealant must prevent seepage of fuel through structural joints. Thus it must have elastomeric flexibility, adhere to the metal with a tacky-type adhesion, resist extraction by fuel, and retain these properties over a wide temperature range. The perfluoroalkyleneetheroxadiazole system has led to the development of such a sealant that has excellent fuel resistance and thermal stability. The polymerization, formulation and testing of the developed channel sealant are described in the following sections.

3.1 POLYMERIZATION

The channel sealant polymer was prepared from perfluoroalkyleneetherdiamidoxime (EDAF diamidoxime, I) and perfluoroalkyleneetherdinitrile (EDAF dinitrile, II).

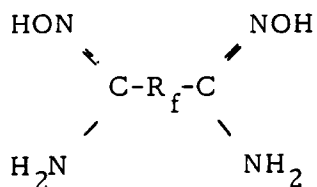

I

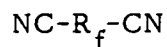

II

where:

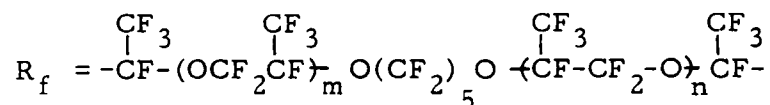

and

$$m + n = 6$$

The IR spectra of the starting materials, as well as the intermediates of the polymerization, were measured to establish baseline information and are included herein (Figure 1 through 3). The composition of the polymerization was

4 g of EDAF dinitrile
10 g of EDAF diamidoxime

The reaction was performed in a flat container in a convection oven. The polymer was cured in sections no thicker than 1/4 inch so that volatile byproducts that affect the ultimate cure of the polymer could be removed. The polymer intermediates were mixed while heating to 127°C (260°F) for six hours, then cured for 70 hours at 154°C (310°F), followed by 24 hours at 177°C (350°F). This cure schedule was determined to be appropriate for small amounts. On scaling up the polymerization, this schedule could not be adhered to strictly.

Monitoring the extent of advancement of polymerization at 177°C (350°F) by thermogravimetric analysis became essential. Handling and physical characteristics along such as snap, tackiness, and color were too qualitative to be used as methods for determining degree of polymerization and crosslinking. The extent of polymerization is the single most important factor affecting thermal stability and mechanical properties of the polymer and is indicated by the molecular weight. Observation via standard TGA of the onset of degradation temperature (which should be no less than 300°C, and weight loss at 300°C for 15 hours, which should be no greater than 5 percent for the best performing material), denotes a polymer of sufficiently high a molecular weight for compounding into a sealant.

The polymerization that resulted in polymer QB-3 was noteworthy for achieving a high of 360°C for the onset of degradation as well as no greater than 5 percent weight loss for 15 hours at 300°C. The cure schedule for that particular run was six hours at 127°C (260°F), 72 hours at 154°C (310°F), 20 hours at 177°C (350°F). Formulation of the polymer has been well defined as the following sections indicate; however, the polymerization of the two starting materials still must be investigated more carefully. A study of polymerization under vacuum with continuous stirring and gradually applied heat to establish a cure schedule is needed. Also the reproducibility of the polymerization process

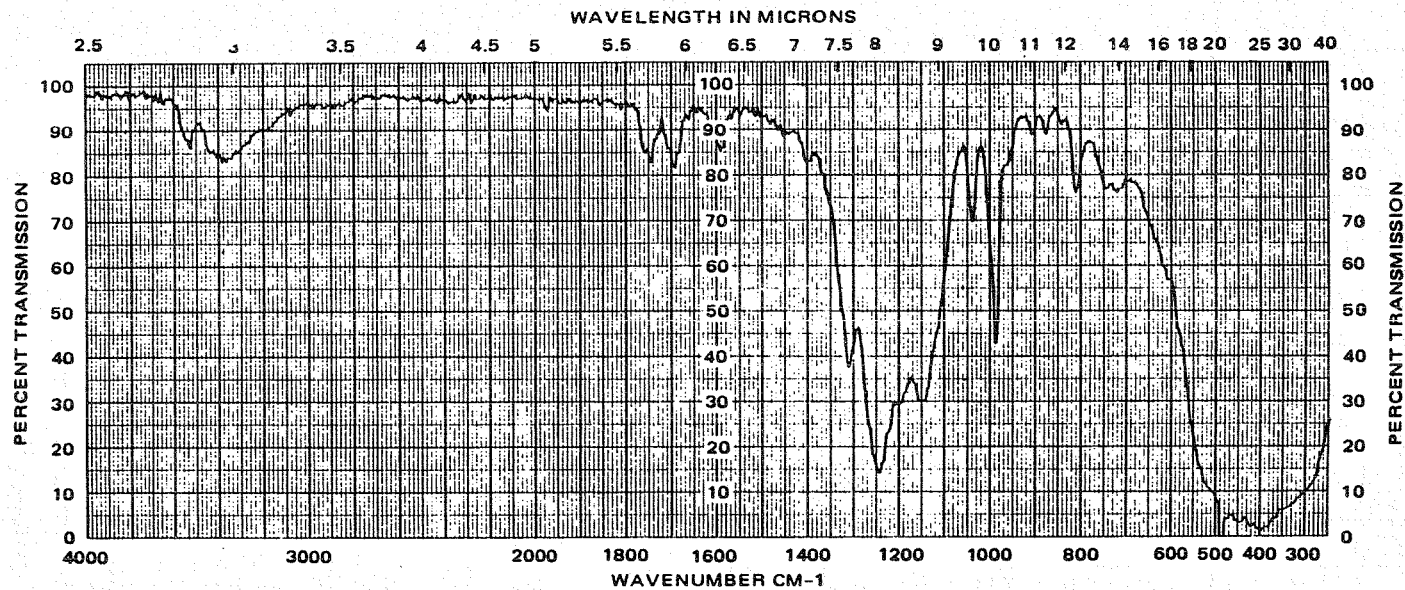

Figure 1. IR of EDAF diamidoxime prepolymer.

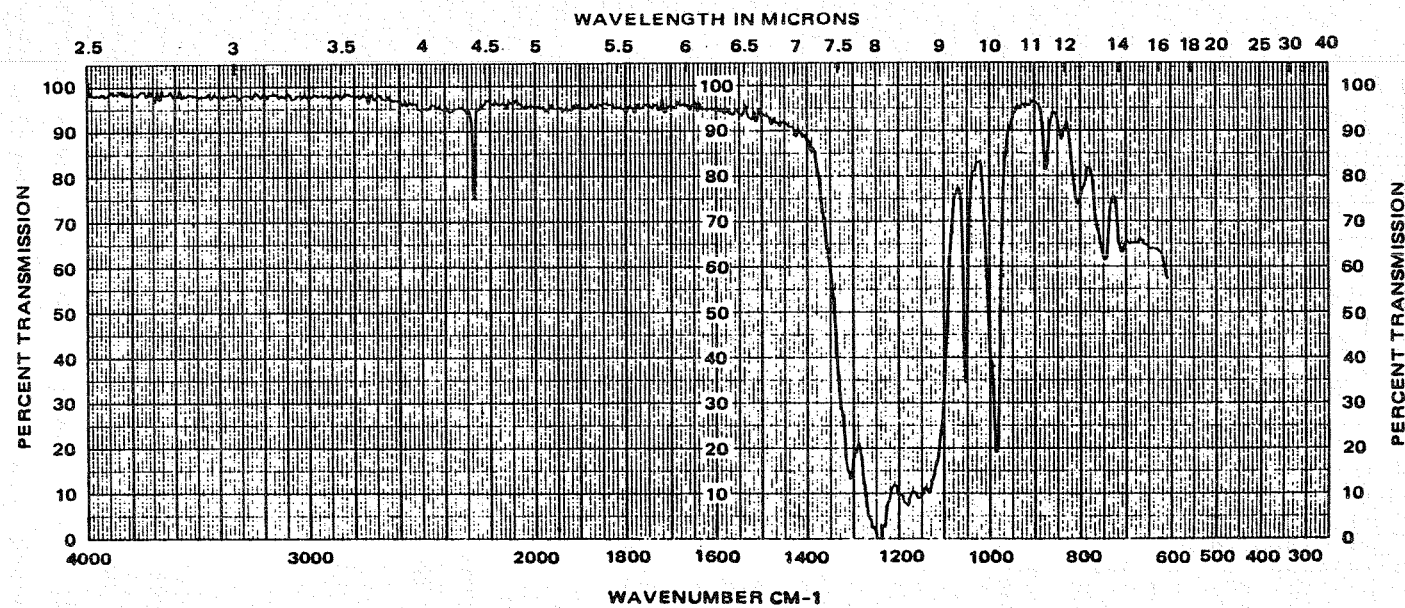
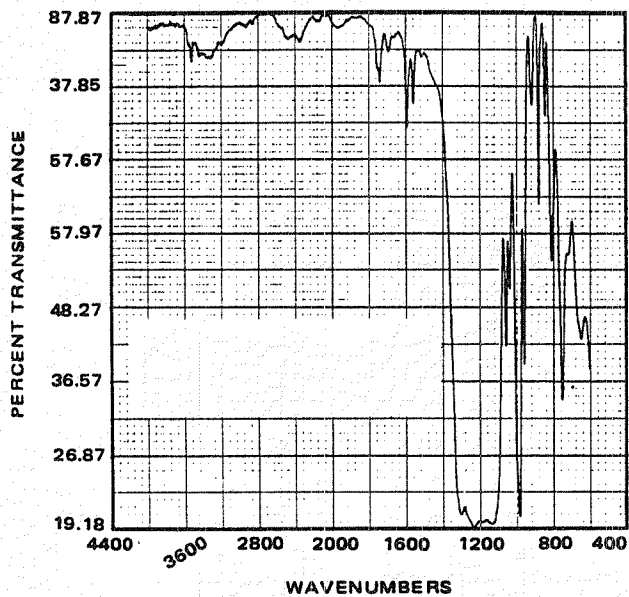
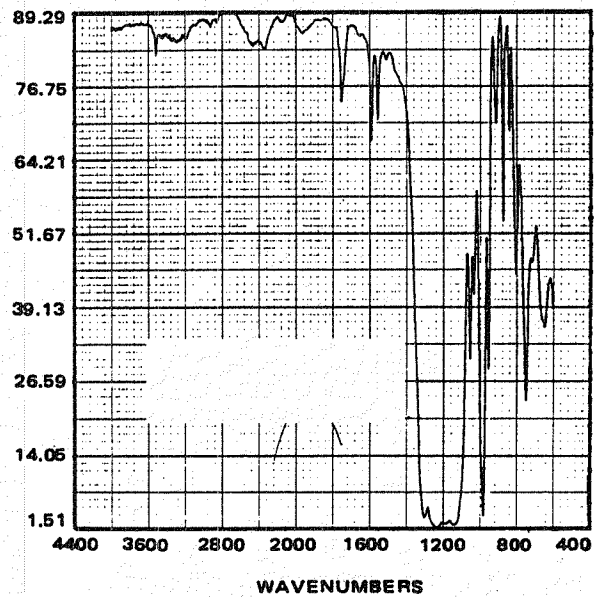

Figure 2. IR of EDAF dinitrile cross-linker



a. After 36 hours



b. After 72 hours

Figure 3. IR of channel sealant at 154°C (310°F).

needs more development to bring out the full potential of this remarkable polymer.

3.2 FORMULATION

Additives and fillers were evaluated in the first year of the program. The materials selected as the components of the final formulation contributed the requisite properties to the channel sealant. The optimum formulation established for the channel sealant was

Polymer	10.0 parts by weight
Lithafrax 2122	5.5 parts by weight
Asbestos RG-244	1.5 parts by weight
MD-1024	0.5 parts by weight

First for thixotropy and reinforcement, asbestos fibers were used. In the channel sealant formulation, the optimum loading selected was 12 to 17 percent by weight in asbestos. This filler was chosen for its unique properties as a result of work done at the beginning of the program. Other fillers used included Lithafrax 2122 (80 percent by weight) to lower the thermal expansion coefficient of the sealant and MD-1024 (5 percent) to prevent oxidative degradation by

trace amounts of metal. Work early in the program indicated that the use of this metal deactivator, MD-1024, improved the tack retention and softness of the formula on aging. The effect on thermal properties of the channel sealant by the MD-1024 was determined by preparing two identical formulations, nos. 150 and 151, except for the addition of MD-1024 to no. 150. Then the formulations were evaluated by isothermal thermogravimetric analysis (TGA).

The thermograms are shown in Figure 4. The no. 150 sample exhibits some early weight loss of some volatile products but then appears to stabilize. The benefits of the metal deactivator outweigh the early loss of volatile products.

The materials used as fillers and their sources are listed in Table 1. The various formulations of the channel sealant are listed in Table 2.

First, the asbestos was milled in to achieve proper wetting of the fibers, which took at least 30 minutes on the rubber micromill* (Figure 5). Then, the other fillers were added gradually and milled until the polymer banded correctly on the mill. The entire milling process was performed in a dry box (Figure 6) especially set up for working with asbestos.

The polymer was removed from the rollers after compounding and post-cured another hour at 154°C (310°F) before the samples were prepared. Sometimes, as with the peel adhesion samples, the cure was postponed until after

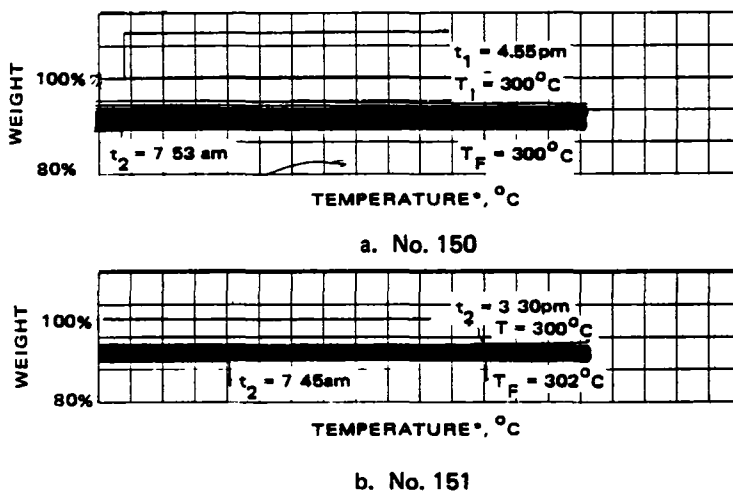

Figure 4. Isothermal TGAs.

*The rubber mill was manufactured by Coastcraft Rubber Co., Inc. It is a two roll mill; the roll diameters are 1 inch and 1.175 inches. The roll speed is 19 rpm. It has a 1/3 horsepower motor.

TABLE 1. FILLERS AND ADDITIVES USED DURING THE STUDY

Material	Source	Description	Function
Thermax	R.T. Vanderbilt	Carbon Black	Reinforcement
RG244 "Calidria"	Union Carbide	Asbestos	Thixotropy
Lithafrax 2122	Carborundum	Lithium aluminum silicate	Lower thermal expansion coefficient
A-187	Union Carbide	(γ -glycidoxypropyl) trimethoxysilane	Adhesion/reinforcement
Irganox MD-1024	Ciba-Geigy	Hindered phenolic anti-oxidant metal deactivator	Prevents oxidative degradation by trace amounts of metal
A-1100	Union Carbide	γ -aminopropyl-triethoxysilane	Adhesion/reinforcement
Epon 1001	Shell Chemical	Bisphenol A based epoxy	Adhesion
Processed mineral fiber (PMF)	Jim Walker Resources, Inc.	Calcium-alumino silicates	Reinforcement
Kevlar	DuPont	Aramid fiber	Reinforcement

TABLE 2. CHANNEL SEALANT FORMULATIONS*

Sealant	Polymer 5.0g	Lithafrax	Asbestos	MD-1024	Other
130	J-5	5.0	0.25	----	
132	N-0	2.75	0.75	0.24	
136	N-0	2.65		0.25	
140	M-0	2.75	0.70	0.20	
150	M-1	2.75	0.75	0.24	
151	M-1	2.75	0.75	----	
163	Q-A	2.75		0.25	0.25 Kevlar
164	Q-A	2.75		0.25	0.75 PMF
165	Q-B2	2.75	0.60	0.25	
170	Q-B3	2.75	0.75	0.25	

the sample was prepared to ensure better adherence of the sealant to the substrate.

Most of the tests were run on the formulation on page 10 or small variations thereof.

Because of the safety problems inherent in the use of asbestos, two alternate reinforcing fibers, processed mineral (PMF) and aramid (Kevlar), were investigated. The PMF filler at a 35 percent loading could not provide the strength necessary as evidenced by excessive flow at higher temperatures. The extensive milling that was required chopped up the fibers and reduced their strength. Kevlar fibers of 0.16 cm (0.062 inch) length were difficult to mill in, and only a 5 percent loading was achieved. Furthermore, the product was stringy and not uniform. Further investigation of alternate fillers was discontinued after these attempts because filler development was beyond the primary scope of the program.

3.3 PHYSICAL PROPERTIES

The channel sealant formulation was evaluated to determine selected properties per MIL-S-8802D and MIL-S-81323 (WP).

*In parts by weight.

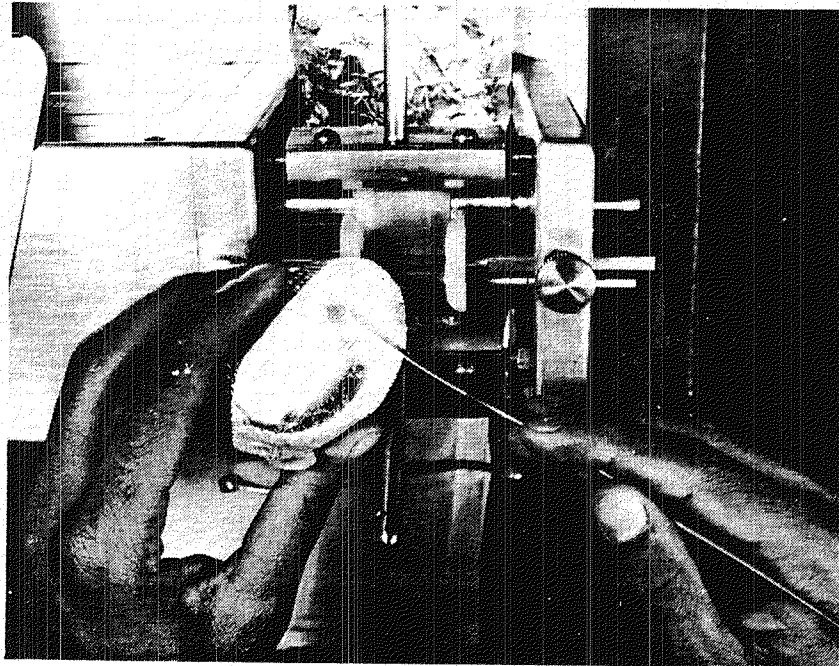

4R-48858

Figure 5. Rubber micromill

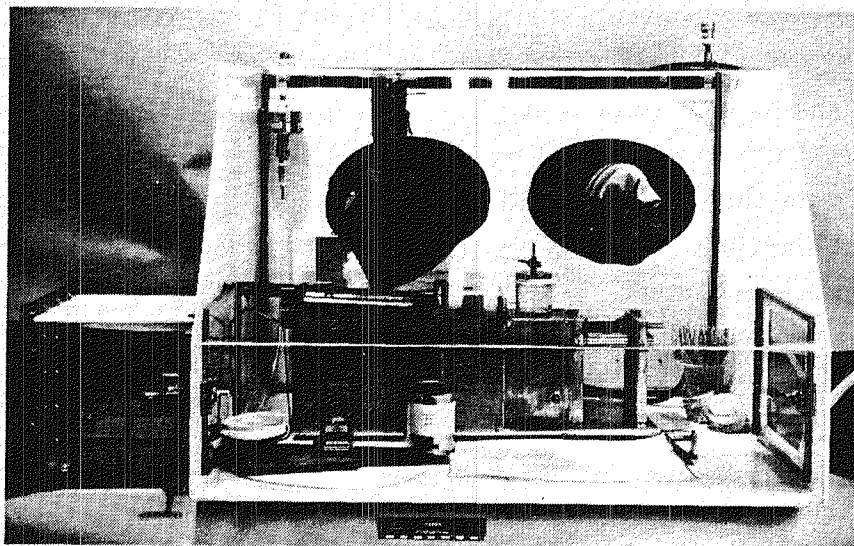

4R-59394

Figure 6. Dry box for asbestos formulation with two-roll micromill.

The specific gravity was determined on the test panels prepared for the fuel resistance test. These test panels were 0.081 by 5.08 by 5.72 cm (0.032 by 2 by 2.25 inches) of aluminum. The panels were weighed accurately before and after application of the sealing compound, in air and distilled water at room temperature. The specific gravity was determined on six samples of formulation no. 165 by the following calculations:

$$\text{Specific Gravity} = \frac{W_1 - W_3}{(W_1 + W_4) - (W_2 + W_3)}$$

W_1 = weight of panel in air

W_2 = weight of panel in water

W_3 = weight of panel and sealing compound in air

W_4 = weight of panel and sealing compound in water

The results are given in Table 3.

The nonvolatiles content was determined on two five gram samples of formulation no. 165. The specimens were placed in tared containers, reweighed and heated for seven days uncovered at 70°C (158°F). The containers were covered and cooled in a dessicator and then reweighed. The percentage of the total nonvolatile content was calculated as

$$\text{Percent nonvolatile content} = \frac{\text{final weight}}{\text{initial weight}} \times 100.$$

The results are given in Table 3.

MIL-S-81323 (WP) calls for a maximum specific gravity of 1.75 and nonvolatiles content of not less than 98 percent. In the channel sealant, the specific gravity was 1.77, and all the samples measured were within 8 percent of the average value. The 55 percent content in Lithafrax (density = 2.40), and 15 percent in asbestos (density = 2.45) accounts for the high specific gravity. The variations in the value are caused by the difficulty in obtaining a uniform dispersion of fillers within the polymer matrix.

TABLE 3. PHYSICAL PROPERTIES OF FORMULATION 165

SAMPLES	SPECIFIC GRAVITY	PERCENT NONVOLATILES	
A	1.82		
B	1.81		
C	1.74		
D	1.63	Average 1.77 ± 0.14	
E	1.75		
F	1.87		
1		99.82	Average
2		99.82	99.82

3.4 MECHANICAL TESTING

Several of the channel sealant formulations were subjected to mechanical tests. Some of the tests are representative of the conditions under which the sealant will perform, and others provide more information as to the behavior of the material for other applications. The materials were subjected to pressure rupture resistance, and peel adhesion testing after fuel immersion and heat aging. Low temperature flexibility was also evaluated.

3.4.1 Pressure Rupture Resistance

Pressure rupture resistance was evaluated per the procedure outlined in MIL-S-81323. The pressure rupture test fixture is shown in Figure 7. Pressure rupture blowout test specimens are shown in Figure 8.

The sealing compound was packed into three blowout specimens and stabilized at 25°C (77°F) for 24 hours. The specimens were cooled to below -29°C (-20°F), and the excess material trimmed from the surfaces with a razor blade. The specimens were then tested as described below. One specimen was mounted in the pressure rupture jig. One air hose bib of the apparatus was connected to a manometer, the other to a variable pressure source. The assembly was immersed in a water bath at 25°C (77°F) and stabilized for 5 minutes. Starting at atmospheric pressure, the pressure was increased uniformly at the rate of 1 inch of mercury per 15 seconds until failure occurred. A continuous

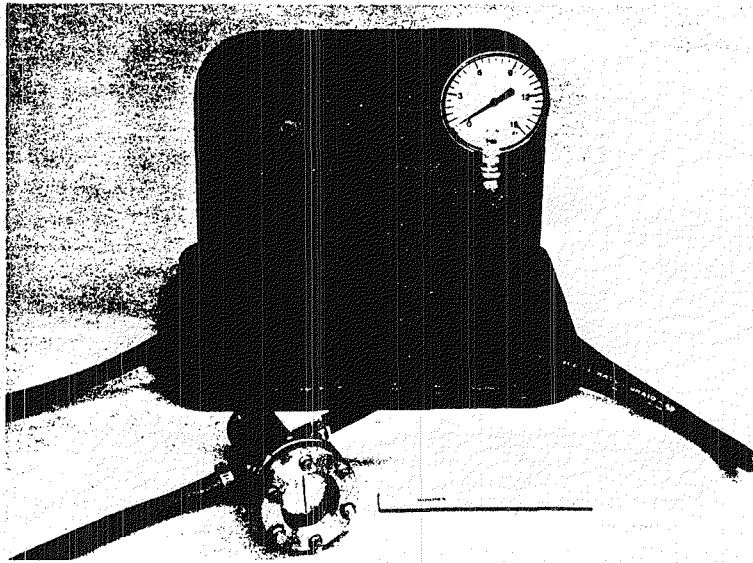

Figure 7. Pressure rupture test fixture.

stream of air bubbles coming from the specimen constituted failure. Three specimens were tested as above. Three other samples were immersed in JRF for 120 hours at 49°C (120°F) plus 60 hours at 71°C (160°F) and 6 hours at 82°C (180°F). These were then removed and tested as described above for pressure rupture resistance. Another set of three samples were tested for pressure rupture resistance at an elevated temperature by placing the pressure rupture jig assembly in an oven at 177°C (350°F) and testing after stabilization for 15 minutes. Failure was indicated by a rapid drop in pressure.

Pressure rupture testing was evaluated on formulation 140, originally rejected because of a lack of tack and adhesion. The use of a 1-hour test aging step at 177°C (350°F) after milling made the formula tacky. This formulation was evaluated for resistance to pressure rupture. The results are presented in Table 4. The results demonstrate that the material far exceeds the minimum requirements per MIL-S-81323 (WP) both before and after exposure. An additional test was performed in which the test samples were not stabilized for 24 hours before removal of excess sealant and subsequent testing as required in the specification. The lower value for this test indicates that the increase in adhesion with the channel sealant is time-related.

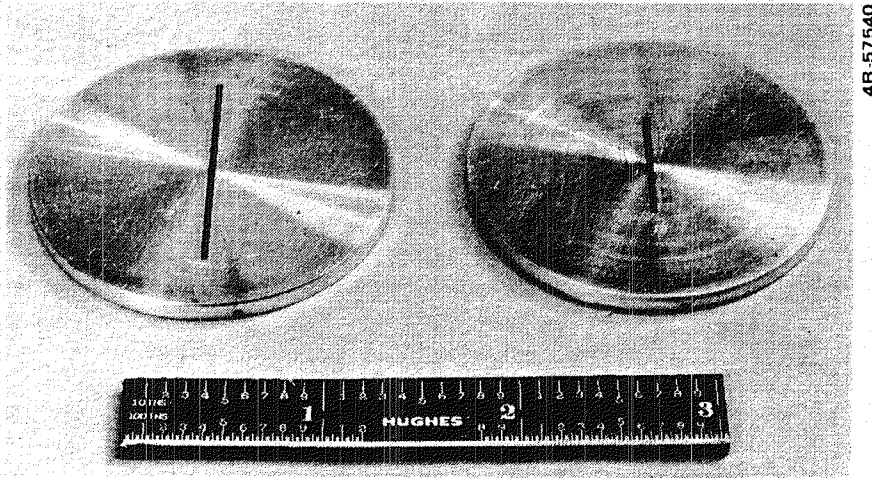

Figure 8. Pressure rupture blowout test specimens

TABLE 4. RESISTANCE TO PRESSURE RUPTURE TESTING, FORMULATION 140

Sample	Control Test Results No Aging*	Control Test Results 24-Hour Aging*	JRF Immersion Test Results	177°C (350°) Test Results
1	9	7.5	15	15
2	8	11.0	15	11
3	8	10.5	15	15
Average	8.3	9.7	15	13.7
Minimum Average Requirement	---	5.9	1.7	1.7

*The test method calls for a 24-hour stabilization before removal and testing of pressure rupture specimens.

3.4.2 Adhesion

Adhesion in peel was evaluated on formulation 165 per MIL-S-8802D. Two samples each were prepared on aluminum and titanium to be immersed in JRF for 7 days at 60°C (140°F). Two other samples each were prepared on aluminum for immersion at 60°C (140°F) into equal parts of JRF and 3 percent aqueous sodium chloride solution for seven days and for 70 days with fluid change every 14 days on the latter. Also, two samples were prepared for the 70-day test at 60°C (140°F) for immersion in JRF with fluid change every 14 days. Two samples were prepared with formulation 170 and immersed in the salt water/JRF medium for fourteen days.

The results show that immersion in JRF over the seven days was not detrimental to formulation 165, whereas immersion in salt water was. Early in the program, immersion in the 3 percent salt solution was found to be the most severe test of the polymer. Even with the presence of MD-1024, the sealant had degraded severely after exposure for two weeks with fluffy matter appearing in the solution. The polymer QB-2 from which this formulation is derived had exhibited onset of degradation at 340°C by TGA, indicating a sufficiently high degree of crosslinking.

Formulation 170, based on polymer QB-3, then was subjected to a 14-day immersion test in salt water/JRF. The results showed that the two samples of 170 had better resistance to the salt water environment. QB-3 polymer, as mentioned earlier, had achieved a higher degree of thermal stability than the polymer QB-2 (basis for 165) before formulating. The higher molecular weight necessary for thermal stability is also a primary requirement for corrosion resistance. The results are summarized in Table 5.

3.4.3 Low Temperature Flexibility

The low temperature flexibility test was performed as described below. The sealant was applied as a 10.2 x 0.64 centimeters (4 x 1/4 inch) strip on a 15.2 x 2.54 x 0.16 centimeters (6 x 1 x 0.062 inch) aluminum coupon. The test fixture consisted of a support fixture with a 10.2 cm (4 inch) span and a circular mandrel 10.2 cm (4 inches) in diameter (Figure 9). The sample and test fixture were placed into an environmental chamber mounted on an Instron

TABLE 5. ADHESION IN PEEL PER MIL-S-8802D, FORMULATION 165 AND 170

Substrate*	Post Cure Temperature	Medium Immersion 60°C (140°F)	Days in Test	Average Peel Strength pounds per inch width	Type of Failure	Sealant Appearance
Formulation 165						
Aluminum	154°C (310°F)	JRF	7	4.4	Cohesive	Putty like
Titanium	154°C (310°F)	JRF	7	6.1	Cohesive	Putty like
Aluminum	154°C (310°F)	3% aq. NaCl/JRF	7	0.4	Cohesive	Putty like
Titanium	154°C (310°F)	3% aq. NaCl/JRF	7	1.3	Cohesive	Putty like
Aluminum	154°C (310°F)	JRF	70	0.60		
Aluminum	154°C (310°F)	3% aq. NaCl/JRF	21		Complete failure	
Formulation 170						
Aluminum	154°C (310°F)	3% aq. NaCl/JRF	14	1.5	Cohesive	Putty like

* Surface Preparation: Ajax scrub, apply 1 percent solution of A-187 silane in methanol, dry at R.T. for 1 hour.

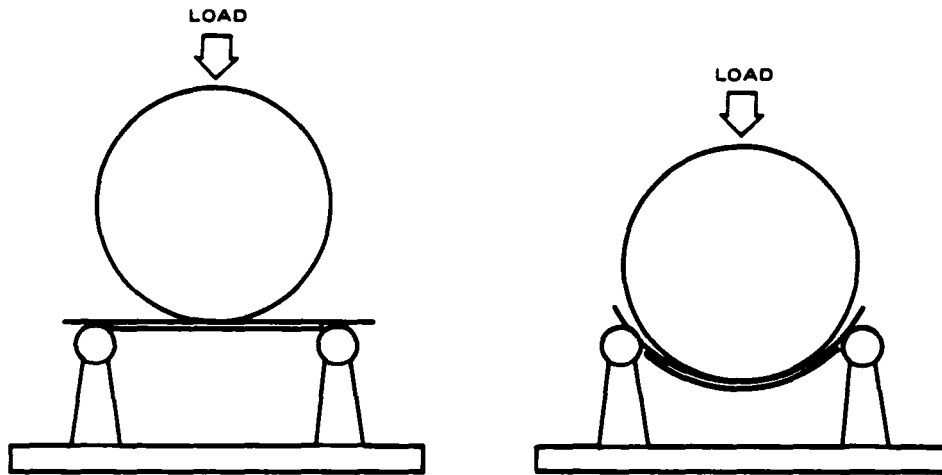

Figure 9. Low temperature flexibility test fixture

Mechanical Testing machine. The environmental chamber was then cooled to and maintained at -54°C (-65°F). After thermal equilibrium, the sample was placed on the support fixture and the mandrel placed on the sample. After another period of thermal equilibration, the mandrel was driven down 3.94 cm (1.55 inches) at a rate of 50.8 cm/min (20 inches/min), bending the sample around the mandrel. The load was removed, then the sample was examined for cracking, flaking and other failures. Formulation 165 tested in this manner developed four cracks 0.16 cm (0.062 inch) in length at the outside edges of the sample. The material did not flake and otherwise kept its integrity.

3.5 SEALING EFFICIENCY

Gap sealing efficiency testing on formulation 165 was initiated per MIL-S-81323 (WP) using 5 mil spacers. The sealant was pressed by hand into the groove of the jig (Figure 10), which was then closed up, tightened and leak tested at 10 psi. The jig, containing 3 percent aqueous sodium chloride, was then immersed in a water bath, heated to 49°C (120°F). The testing schedule for gap seal efficiency was

49°C (120°F) for 25 days, then
 71°C (160°F) for 60 hours, then
 82°C (180°F) for 6 hours.

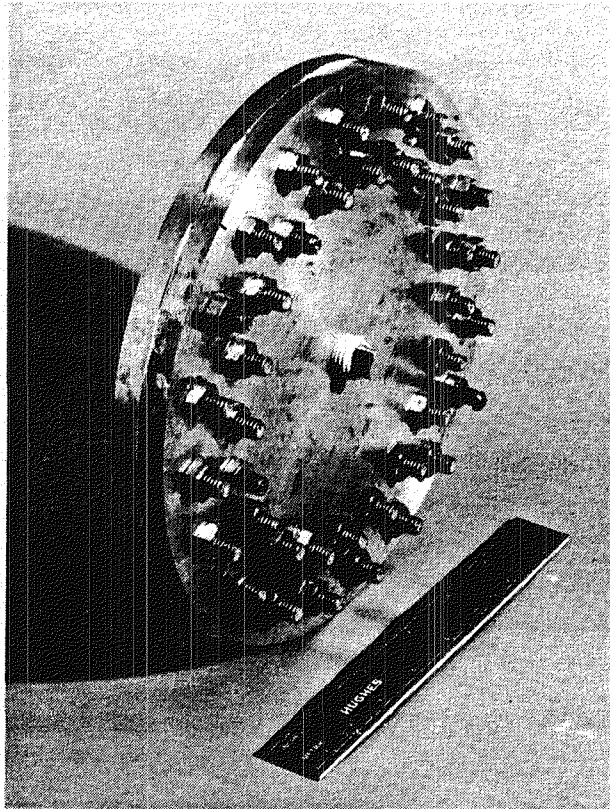

Figure 10. Gap sealing efficiency test fixture

The jig was drained, placed in an oven at 177°C (350°F), stabilized and checked for leakage at 5 psi for 2 hours. Then a pressure of 10 psi was applied for one minute, and the jig was checked for leakage. A second jig was set up similarly containing jet reference fuel (JRF) and also immersed in a 49°C (120°F) water bath.

The test schedule for the second jig was

49°C (120°F) for 100 hours, then
 71°C (160°F) for 10 hours, then
 82°C (180°F) for 1 hour.

The jig was drained and dried in an oven at 107°C (225°F) for 20 hours, 10 hours at 154°C (310°F) and 1 hour at 177°C (350°F) with 5 psi applied continuously. Then, the pressure was increased to 10 psi for 1 minute.

The gap sealing efficiency test of the material was repeated with 10 mil spacers using the test schedule of the jig filled with JRF. The results of these tests are summarized in Table 6. These results indicate that the material was able to seal 5 mil gaps well enough; however, salt water resistance

TABLE 6. GAP SEALING EFFICIENCY OF FORMULATION 165

Gap Size, Mils	Medium	Results
5	JRF	A slow leak developed with 10 psi pressure at 177°C (350°F)
5	3% aq. NaCl	A slow leak developed at 5 psi pressure at 177°C (350°F)
10	JRF	Held 5 psi pressure for 45 minutes at 177°C (350°F), then a leak developed

was a problem with formulation 165. The test with 10 mil spacers shows an increased rate of leakage; therefore, the test with 15 mil spacers was not attempted with this formulation.

3.6 FUEL AND CORROSION RESISTANCE

3.6.1 Fuel Resistance

Fuel resistance was determined per MIL-S-81323 (WP) for formulations 166 and 170. After 25 days immersion in JRF at 49°C (120°F) three samples (165) showed an average of 12.44 percent volume change (swelling). Two samples (170) were immersed in JRF for 25 days at 49°C (120°F), plus 60 hours at 71°C (160°F), plus 6 hours at 82°C (180°F). The volume change and weight change for the two samples averaged -9.93 percent and -0.24 percent, respectively. A separate sample of 165 had a volume change of -6.87 percent.

3.6.2 Corrosion Resistance

The test procedure involved the use of a 3 percent sodium chloride water solution layer topped with a layer of Jet Reference Fuel (JRF) sealed in a container with fillets of sealant exposed to the layers and JRF vapor phase. The composition of JRF is

Toluene (technical grade)	30 volumes
Cyclohexane (technical grade)	60 volumes
Iso-octane	10 volumes

Tertiary butyl disulfide (doctor sweet)	1 volume
Tertiary butyl mercaptan	0.015 ± 0.0015 weight percent of other four components

The exposure conditions were 25 days at 49 ±1°C (120 ±2°F) plus 60 hours at 71 ±1°C (160 ±2°F) and 6 hours at 82 ±1°C (180 ±2°F).

The corrosion resistance test results of formulation 140, based on M-O polymer, indicated that the formula would withstand the effects of JRF, the JRF vapor, as well as salt water. In all cases, the material adhered well both to the aluminum panel as well as to the titanium panel. The sealant was still pliable and soft and had not changed color.

3.7 THERMAL EVALUATION

The polymerization of the channel sealant was followed by thermogravimetric analysis (TGA). At various points of cure, standard TGAs were run to determine extent of cure. To establish a baseline during polymerization of Q-A, a TGA was run after 72 hours at 154°C (310°F) (Figure 11a), again after 72 hours at 154°C (310°F) plus 2 hours at 177°C (350°F) (Figure 11b), and after 13 hours at 177°C (350°F) (Figure 11c). An isothermal TGA was also run at that point (Figure 12). At this stage of cure, the onset of degradation temperature was 330°C and the weight loss after 15 hours at 350°C was 8 percent. From previous data gathered on the material, the polymer was considered sufficiently cured for formulating. Other polymerizations that were monitored by TGA and their onset of degradation temperatures are QB-1 (300°C), QB-2 (340°C), QC (320°C), QB-3 (360°C). The TGAs of these polymers are shown in Figure 13. An isothermal TGA of QB-3 (Figure 14) showed a weight loss of 2 percent. The remarkable variation in the temperatures for the onset of degradation points up the problem of reproducibility in polymerization.

The thermal analysis results for the channel sealant polymers are summarized in Table 7.

Thermal analysis on the channel sealant formulations 140 (Figure 15), 165 (Figure 16), 170 (Figure 17) also show the variations possible in the pure

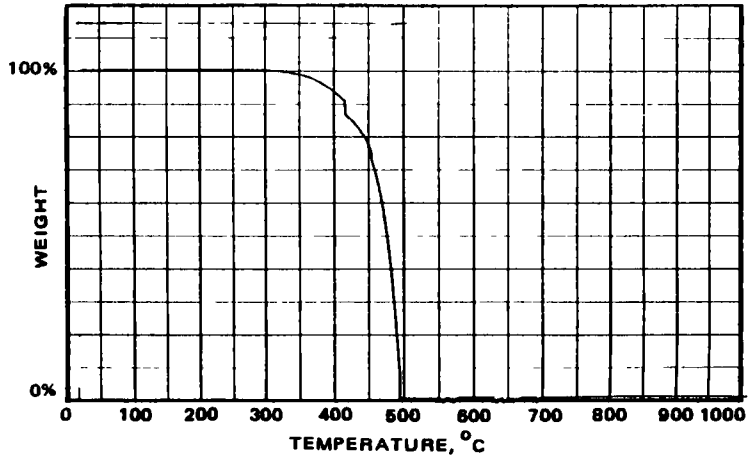

a. After 72 hours at 154°C (310°F)

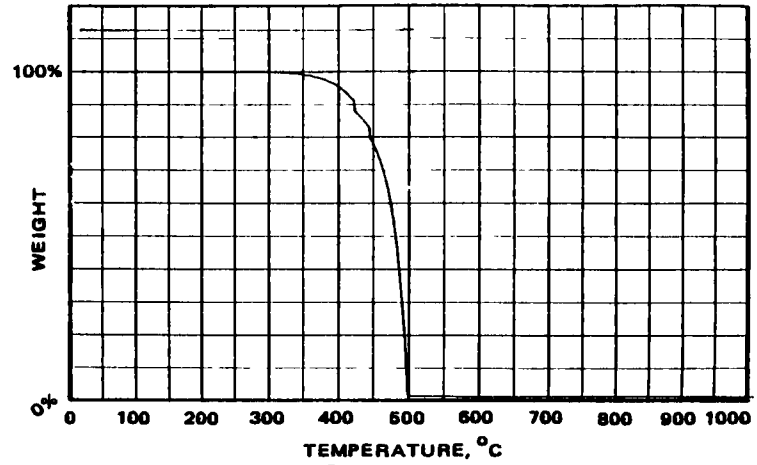

b. After 72 hours at 154°C (310°F), 2 hours at 177°C (350°F)

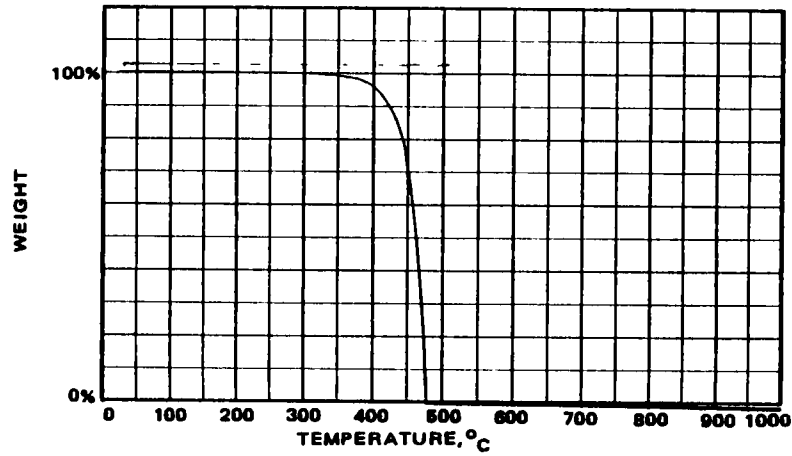

c. After 13 hours at 177°C (350°F)

Figure 11. TGA of Q-A.

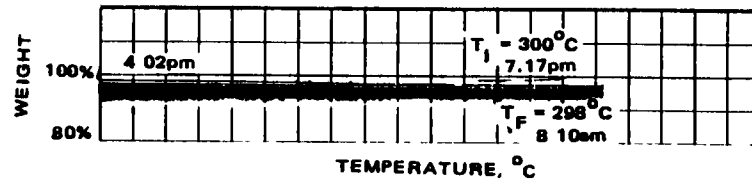
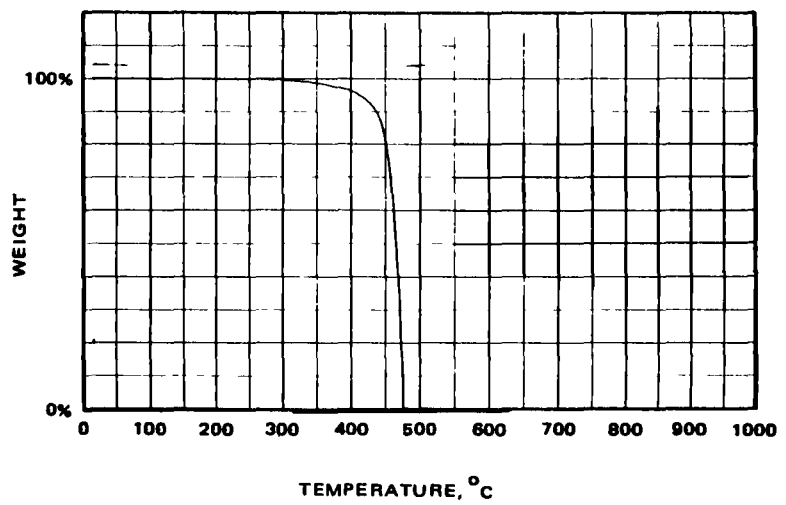
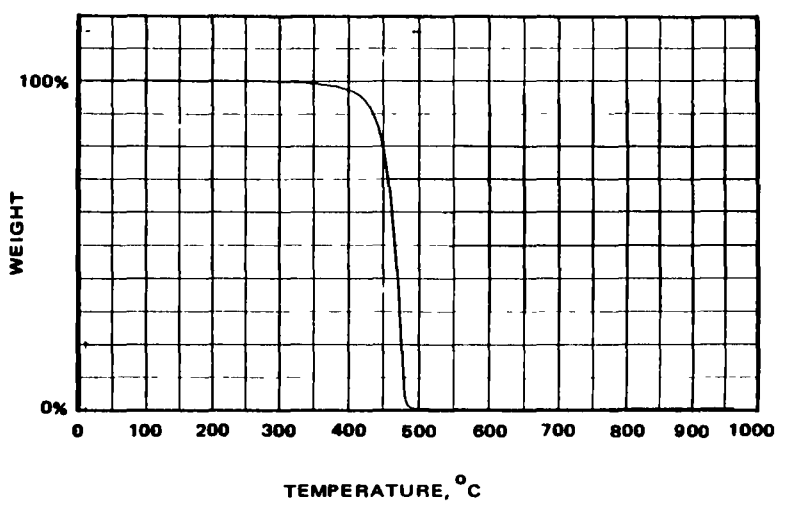

Figure 12 Isothermal TGA of Q-A after 13 hours at 177°C (350°F).



a QB-1



b QB-2

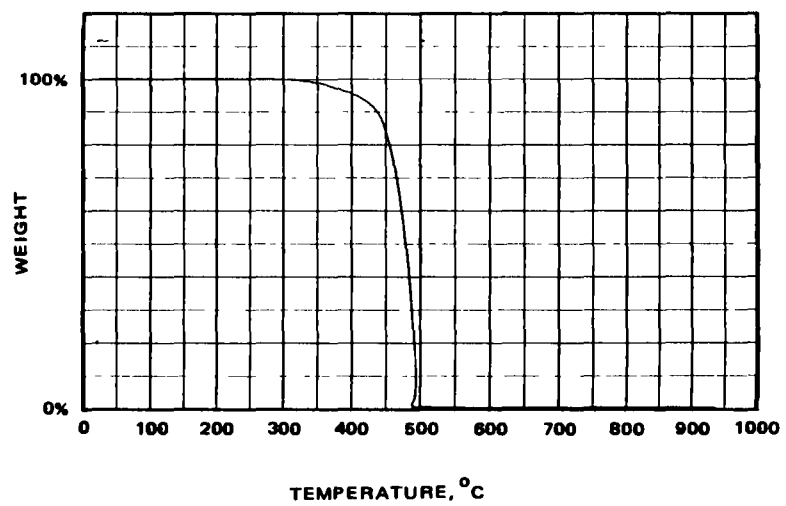

c. QC

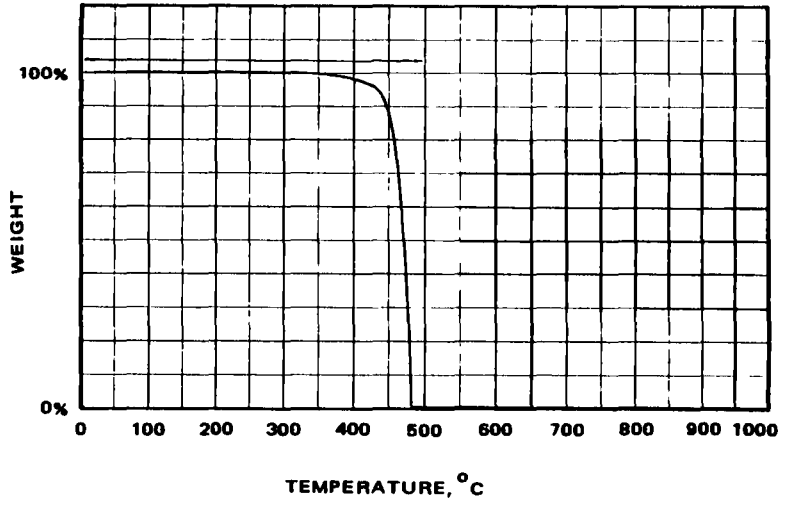

d. QB-3

Figure 13. TGAs of channel sealant polymers.

TABLE 7. THERMAL ANALYSIS SUMMARY OF CHANNEL SEALANT POLYMERS

Polymer	Cure Schedule	Onset of Degradation °C in Air at 20°C/min	Percent Weight Loss in Air 15 hours at 300°C
Q-A	72 hours/154°C	330	
Q-A	72 hours/154°C + 2 hours/177°C	340	
Q-A	72 hours/154°C + 13 hours/177°C	340	8
QB-1	Final cure 23 hours/177°C	300	
QB-2	Final cure 23 hours/177°C	340	
QC	Final cure 25 hours/177°C	320	
QB-3	Final cure 20 hours/177°C	360	5

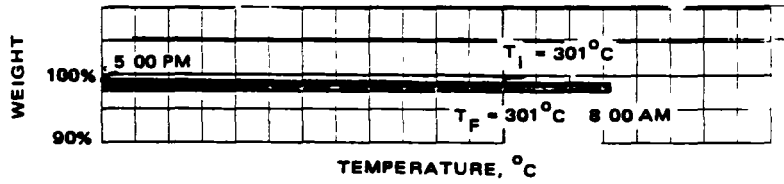

Figure 14. Isothermal TGA of channel sealant polymer QB-3

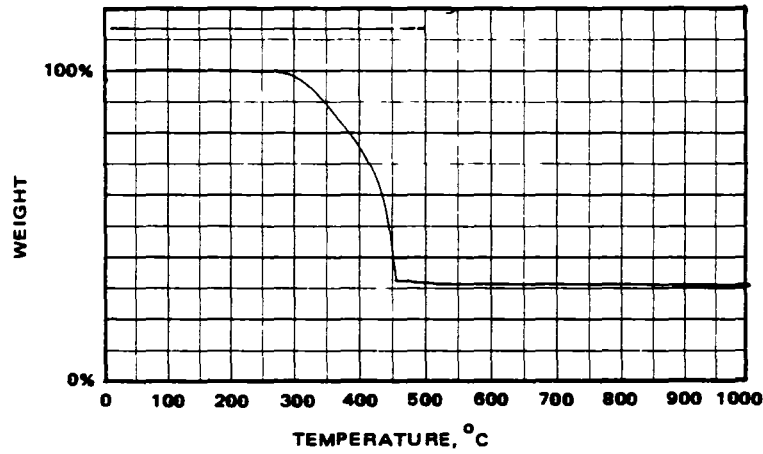
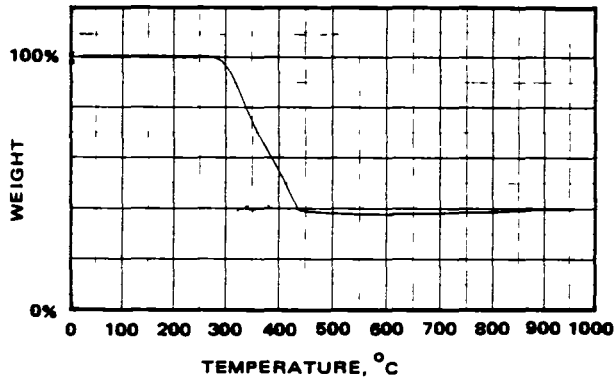
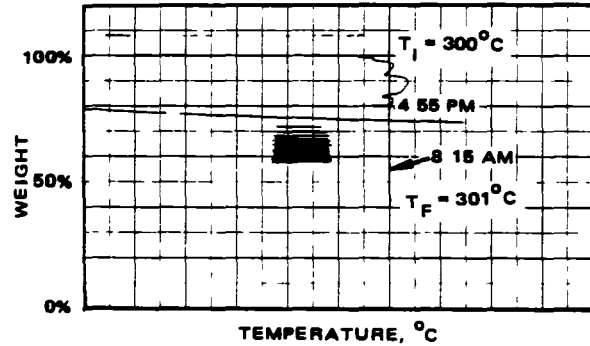

Figure 15. TGA of formulation 140



a. TGA



b. Isothermal TGA

Figure 16. Formulation 165

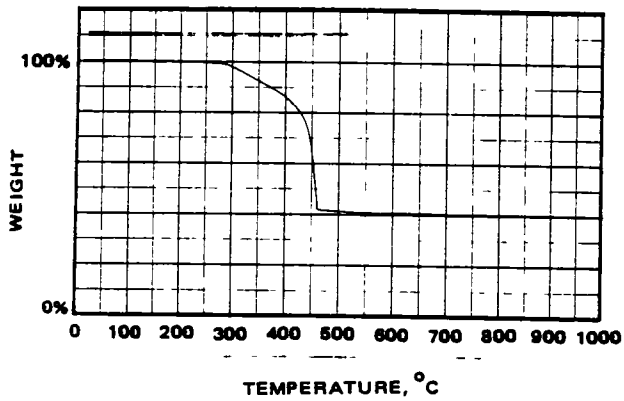

a. TGA

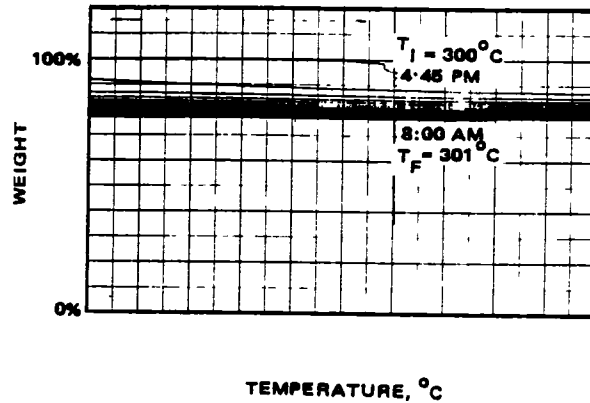

b. Isothermal TGA

Figure 17. Formulation 170

polymer which are then reflected in the thermal analysis and performance, most dramatically in the immersion in aqueous 3 percent sodium chloride.

Thermograms of formulations 163 (Figure 18) and 164 (Figure 19) which are milled with 5 percent Kevlar and 15 percent PMF, respectively, and are both based on Polymer Q-A, indicate that a certain amount of breakdown in thermal stability occurs during the milling process as observed by the onset of degradation temperature, which is 330°C for the unmilled polymer and 270°C and 280°C for formulations 163 and 164, respectively.

The thermal analysis results for the channel sealant formulations are summarized in Table 8.

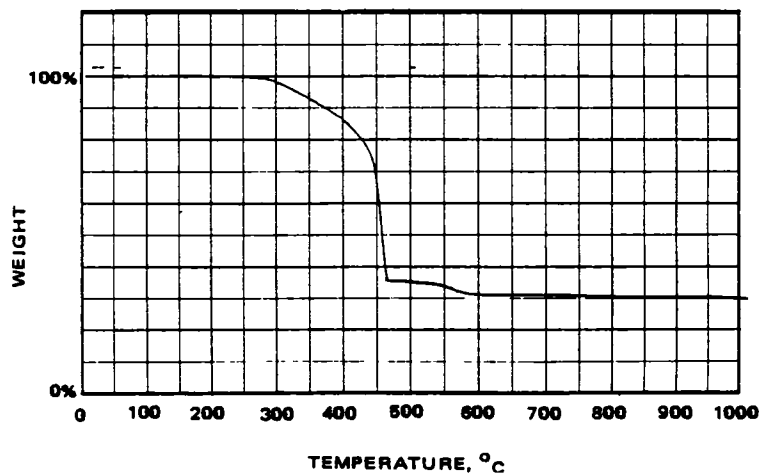

Figure 18. TGA of formulation 163

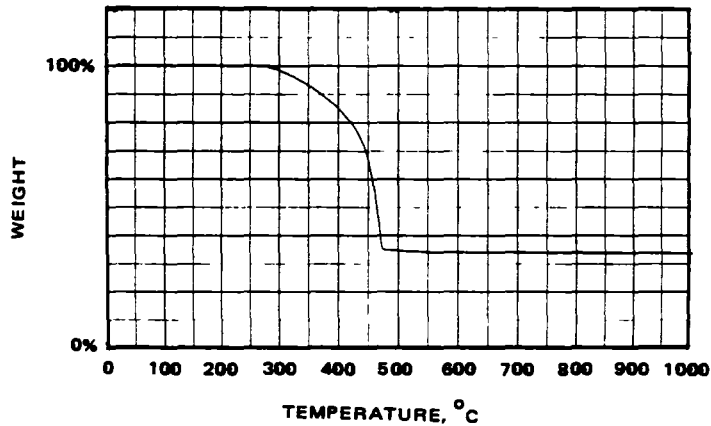

Figure 19. TGA of formulation 164

TABLE 8. THERMAL ANALYSIS SUMMARY OF CHANNEL SEALANT FORMULATIONS

Formulation	Base Polymer	Onset of Degradation °C in Air at 20°C/min	Percent Weight Loss in Air After 15 hours at 300°C
140	M-0	270	
165	QB-2	280	42
170	QB-3	260	23
163	Q-A	270	
164	Q-A	280	

The thermal extrusion test was performed per MIL-S-81323 (WP) by pushing the material into a tube with a rod and then placing it in a 177°C (350°F) oven for 30 minutes. The material extruded 1-1/2 inches on one end and 3/4 inch on the other with a 1/2 inch extrusion from the center holes.

The test fixture used for evaluating thermal extrusion of formulation 165 is shown in Figure 20.

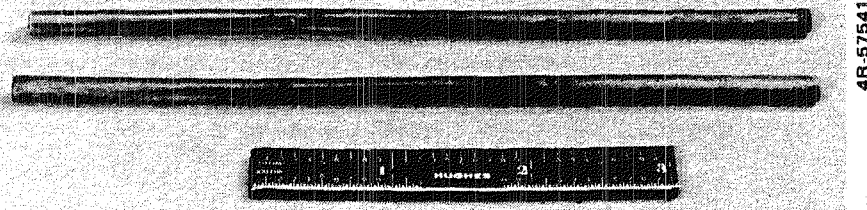

Figure 20. Thermal extrusion test fixture

3.8 PROCESSABILITY

A Monsanto processability tester was used to determine the rheological properties of formulation 165. For each set of data, parameters such as stress and die swell were measured at different shear rates. A given shear rate was obtained by setting the speed of the ram traveling through the barrel for a specified orifice size. The test was run at five different temperatures 30°C (86°F), 70°C (158°F), 100°C (212°F), 160°C (320°F), and 200°C (392°F). At 200°C (392°F), the material extruded by its own weight, and no data were measured. Also, some discoloration of the material was observed at this temperature. Data for the remaining temperatures were applied to a computer program to calculate the viscosity and shear stress at different shear rates.

A Carreau Model, one of the most commonly used equations for expressing the relationship between stress and deformation of viscoelastic materials, has been used in the viscosity computations program. Results are given in Figures 21 and 22. The calculated viscosity versus shear rate at different temperatures is shown in Figure 21. The shear stress versus shear rate at different temperatures is shown in Figure 22. These two graphs indicate the flowability of the polymers at different processing conditions.

Die swell was another rheological parameter measured by the processability tester. Die swell is the ratio of extrudate diameter to the diameter of the die and indicates the degree of recovery of elastic deformation imposed on the material in the orifice. The measured value for die swell is about 70 to 80 percent.

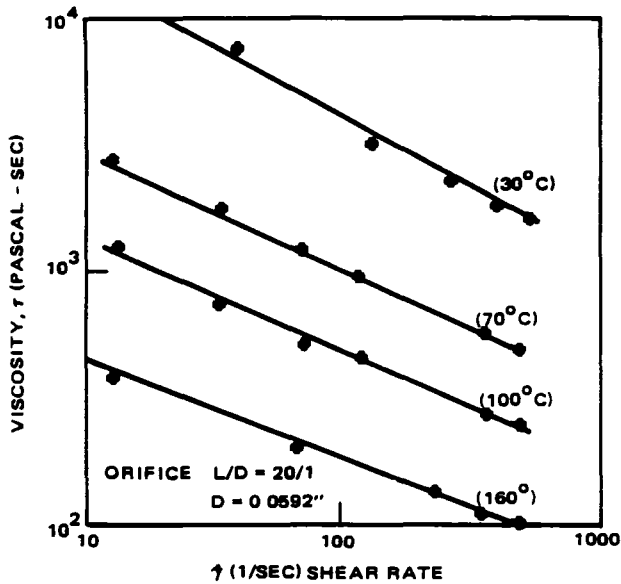

Figure 21. Viscosity versus shear rate at various temperatures

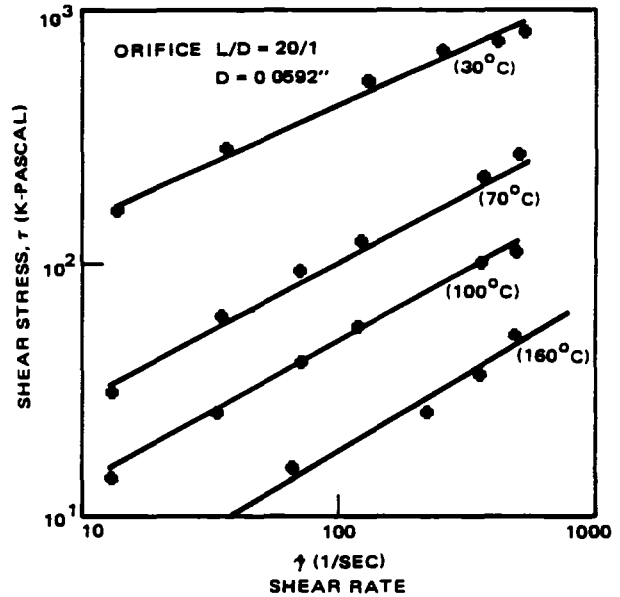

Figure 22. Shear stress - shear rate relationship at various temperatures

A previously used parameter in general used called extrusion rate could also be employed to evaluate the flowability of the material. The following equation defines the extrusion rate at the given processing condition:

$$Q = \frac{R^3 \dot{\gamma}}{4}$$

where:

Q = flow rate or extrusion rate, cm^3/sec

$\dot{\gamma}$ = shear rate, $1/\text{sec}$.

R = radius of the die, cm

The tested material has the usual behavior of viscoelastic materials. Its viscosity decreases by increasing the shear rate or temperature. Generally speaking, the test results indicate that no difficulty should occur in processing this material, even at very low shear rates.

4.0 FILLETING SEALANT

Filleting sealants in fuel tanks are applied by spatula or extruded over seams into joint corners, over fasteners and around other tank intrusions such as hydraulic lines and electrical conduits. The filleting sealant has to be a tough, rubber-like product. The crosslinked poly(perfluoroalkyleneetheroxadiazole) when formulated, makes a filleting sealant that has excellent fuel resistance and thermal stability.

4.1 POLYMERIZATION

The filleting sealant polymer was prepared from the same starting pre-polymers as the channel sealant, namely, perfluoroalkyleneetherdiamidoxime (EDA⁷ diamidoxime, I) and perfluoroalkyleneetherdinitrile (EDAF dinitrile, II). The ratio of I and II, however, was varied for increasing crosslinking in the perfluoroalkyleneether-1,2,4-oxadiazole polymer. The synthesis of the cross-linked poly(perfluoroalkyleneetheroxadiazole) elastomer follows the cure schedule outlined below:

8 g of EDAF dinitrile (II)

10 g of EDAF diamidoxime (I)

As in the channel sealant, the polymerization was performed in a flat container in a thin layer for ease of removal of volatile by-products. The intermediates were mixed while heating to 127°C (260°F) for 6 hours, then cured for 52 hours at 154°C (310°F), followed by 12 hours at 177°C (350°F). As in the channel sealant, the polymerization was monitored by thermogravimetric analysis. The time needed at 177°C (350°F) varied from one polymerization to the other with variation in the thermal stability of the product. Also the handling characteristics of the polymer had to be monitored.

Fillers cannot be added to the polymer before the 12 hours at 177°C (350°F) cure, or a product without integrity and with poor thermal properties will result. If the cure at 177°C (350°F) proceeds much longer than 12 hours, the polymer will not band correctly on the rubber mill, and the final product will have poor adhesion.

4.2 FORMULATION

The filleting sealant formulation was established after some experimentation in the first year of the program. The fillers selected were Thermax (carbon black) and asbestos. Thermax is used for reinforcement of the polymer. Modulus and tensile strength of the polymer are dependent on the degree of reinforcement. Asbestos was advantageous in two areas: (1) it increases tensile strength, and (2) it aids the removal of entrapped gases during high temperature cure, thus eliminating voids.

For better adhesion to substrates, an adhesion promoter was also investigated. Some of the additives tested were Epon 1001 in conjunction with the A-1100 amino silane primer, and A-187, an epoxy silane primer. The epoxy silane was chosen as the less corrosive primer of all those investigated.

The chemical nomenclature and the source of the above fillers and additives were given in Table 1.

The final formulation in parts by weight:

Polymer	10.0
Thermax	8.0
Asbestos RG-244	0.50
A-187 Coupling Agent	0.20

The silane level is critical. High levels of silane reduce the ultimate physical properties as very clearly shown in the tensile strength values of some of the formulations and are discussed in a later section. The filleting sealant formulations that were developed are given in Table 9.

4.3 PHYSICAL PROPERTIES

The filleting sealant formulation was evaluated to determine specific gravity, percent nonvolatiles and hardness (Shore A) per MIL-S-8802D and MIL-S-81323 (WP). The results are given in Table 10.

TABLE 9. FILLETING SEALANT FORMULATIONS

Formulation	Polymer 5.0g	Thermax	Asbestos	MD-1024	Other
126	J-3	4.0	0.25		
127	J-4	4.0	0.25		
128	J-4	4.0	0.17		
129	J-5	4.0	0.25		
131	J-5	4.0		0.20	
133	J-6	4.0	0.25		
134	J-6	4.0	0.17		
135	J-6	4.0	0.17	0.20	
137	J-3	4.0	0.25		
138	J-5	4.0	0.25		
139	J-6	4.0	0.25		
141	J-3	4.0	0.25		EPON 1001 0.5
142	J-3	4.0	0.25		EPON 1001 0.17
143	J-5	4.0	0.25		A-187 0.09
144	J-7A	4.0	0.25		
145	J-6 (aged)	4.0	0.20		
146	J-4	4.0	0.25		
147	J-5	4.0	0.25		A-1100 0.17
148	J-7B	4.0	0.20		
149	J-7B	4.0	0.25		A-1100 30% in methanol 0.18
152	J-5	4.0	0.25		A-187 30% in methanol 0.18
153	J-8	4.0	0.25		
154	J-7B	4.0	0.25		
155	J-9	4.0	0.25		
156	J-9	4.0	0.25		A-187 30% in methanol 0.18
158	J-5	4.0	0.20		A-187 30% in methanol 0.18
159	J-5	4.0	0.20		EPON 1001 0.08
160	J-8	4.0	0.25		
161	J-8	4.0	0.25		A-187 0.10
166	J-10	4.0	0.23		A-187 0.09
172	J-11	4.0	0.23		A-187 0.09
173	J-12	4.0	0.23		A-187 0.10

MIL-S-81323 (WP) calls for a maximum specific gravity of 1.75 and nonvolatiles content of not less than 98 percent. In the filleting sealant, the specific gravity of formulation 166 was 1.42, and all the samples measured were within 8 percent of the average value. The variations in the value are caused by the difficulty in getting a uniform dispersion of fillers within the polymer matrix.

TABLE 10. PHYSICAL PROPERTIES OF FILLETING SEALANT

Formulation-Sample	Hardness (Shore A)	Specific Gravity	Percent Nonvolatiles
166-1 166-2 166-3		1.38 } 1.35 } Average 1.53 } 1.42	
152-1	50	1.87	
166-1 166-B			99.77 } Average 99.75 } 99.76
133 134	40 40		

The nonvolatiles content of the filleting sealant averages to 99.76. Hardness of the three formulations evaluated ranged from 40 to 50.

4.4 MECHANICAL TESTING

The filleting sealant was subjected to low temperature flexibility, stress corrosion, peel adhesion, tensile strength and elongation, shear strength, dynamic mechanical testing and compression set evaluation.

4.4.1 Low Temperature Flexibility

The low temperature flexibility test was performed on one sample of formulation 166 as described below. The sealant was applied as a 10.2 x 0.64 cm (4 x 1/4 inch) strip on a 15.2 x 2.54 x 0.16 cm (6 x 1 x 0.062 inch) aluminum coupon. The test fixture consisted of a support fixture with a 10.2 cm (4 inch) span and a circular mandrel 10.2 cm (4 inches) in diameter (Figure 9). The sample and test fixture were placed into an environmental chamber mounted on an Instron Mechanical Testing machine. Then the environmental chamber was cooled to and maintained at -54°C (-65°F). After thermal equilibration, the sample was placed on the support fixture and the mandrel placed on the sample. After another period of thermal equilibration, the mandrel was driven down 3.94 cm (1.55 inches) at a rate of 50.8 cm (20 inches) per minute, bending the sample around the mandrel. The load was removed and the sample was examined for cracking, flaking and other failures. The results indicate that the material

kept its rubbery consistency and did not flake, although five cracks, 1/2 inch in width, developed in the sample. The sealant retained its adherence to the aluminum substrate over 90 percent of the area. The substrate was bent out of shape, indicating that the test may be too severe.

4.4.2 Stress Corrosion

The stress corrosion of titanium was evaluated at 288°C (550°F). The test used Dow 77-028 high temperature fuel resistant silicone as a control. Stress corrosion tests were run on filleting sealant formulations 128, 156, 161 and 166. Materials were placed on titanium (6 Al-4V) coupons, bowed in an aluminum fixture and subjected to 288°C (550°F). The stress corrosion fixture is shown in Figure 23. After 38 hours, no visual deterioration of formulation 128 or stress cracking of the titanium substrate to which it is bonded was noted. However, the silicone began to shrink and crack, causing it to lift from the titanium. This test was to continue for 500 hours or until complete failure of the sealant occurred.

The stress corrosion results on the filleting sealant are given in Table II. Formulation 128 lasted for about 300 hours at 288°C (550°F) before disintegrating. Formulations 156 and 161 were not as durable; however, 161 did

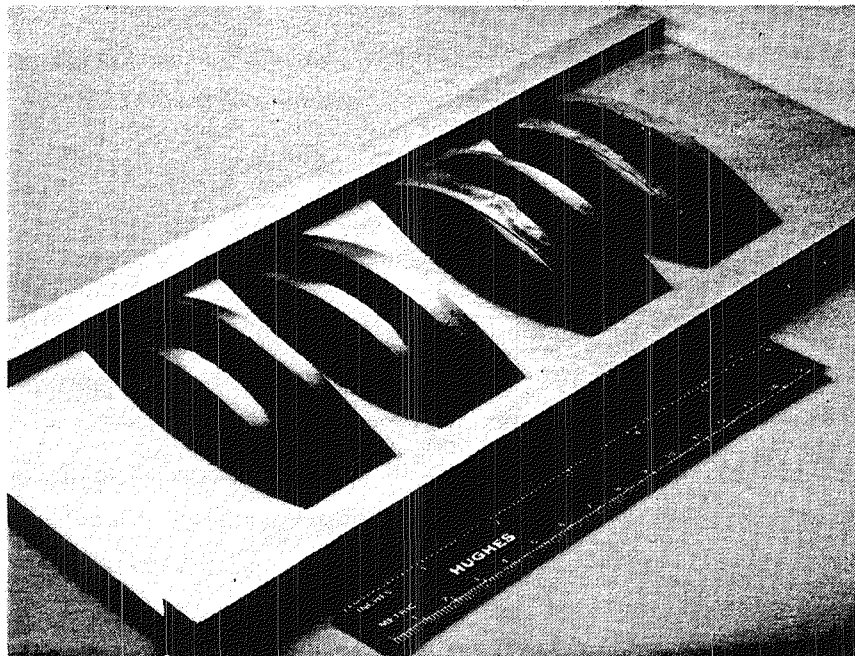

Figure 23. Stress corrosion fixture

TABLE 11. STRESS CORROSION TEST ON TITANIUM

Formulation	Number of Hours at 288°C (550°F)	Comments	Effect on Titanium (6 Al-4V)
128	300	Sealant had disintegrated	No effect
156	160	Sealant had disintegrated	No effect
161	160	Some integrity, even though cracked	No effect
166	240	Intact, crumbles easily	No effect
DOW 77-028 (control)	38	Lifts from titanium; some shrinkage	No effect
Surface Preparation: Treated for 2 hours with Pasa-Gel, primed with 1 percent solution of A-187 silane in methanol			

hold together better than 156 over the period of 160 hours. After 240 hours, the test was discontinued on formulation 166 because the sealant, even though intact, crumbled easily. Examination of the titanium substrate showed no evidence of corrosion. The titanium substrate had been treated in each test for 2 hours with Pasa Gel and primed with a 1 percent solution of A-187 silane in methanol. The surface of the titanium panel remained unaffected by all formulations.

4.4.3 Adhesion

Adhesion testing was performed per MIL-S-8802D, with one exception. The test panels had 0.64 cm (1/4 inch) wide strips of adhesive tested instead of 2.54 cm (1 inch) wide strips because of limited quantities of polymer. Initial results (before immersion in JRF) are given in Tables 12 and 13. It is important to note that the MIL-S-8802D method calls for reporting the numerical average of peak loads.

TABLE 12. ADHESION IN PEEL PER MIL-S-8802D OF VARIOUS FORMULATIONS
TO ALUMINUM PRIOR TO IMMERSION

Formulation	Average Peel Strength, pounds per inch width	Surface Preparation	Type of Failure	Sealant Visual Observations	Post Cure Temperature
127	1.8	(1)	Co	Gummy	154°C (310°F)
127	1.4	(2)	Co	Gummy	154°C (310°F)
127	3.0	(1,4)	LLCo	Soft	177°C (350°F)
127	2.3	(2,4)	LLCo	Soft	177°C (350°F)
127	1.9	(1)	Co	Gummy	166°C (330°F)
126	2.4	(1)	LLCo	Soft rubber	166°C (330°F)
126	4.8	(3)	LLCo	Soft rubber	166°C (330°F)
126	1.6	(2)	LLCo	Soft rubber	166°C (330°F)
141	4.8	(3)	Co	Very hard cheeseey	154°C (310°F)
142	0	(3)	Ad	-----	166°C (330°F)
147	0.5	(2)	Co	Hard, cheeseey	166°C (330°F)
147	0.4	(1)	Co	Hard, cheeseey	166°C (330°F)
146	2.4	(1)	Co	Hard, cheeseey	154°C (310°F)
145	8.0	(1)	40% Ad 60% Co	Rubber	154°C (310°F)
148	5.0	(1)	Co	Rubber	154°C (310°F)

(Continued next page)

(Table 12, concluded)

Formulation	Average Peel Strength, pounds per inch width	Surface Preparation	Type of Failure	Sealant Visual Observations	Post Cure Temperature
149	7.7	(1)	Co	Rubber, some foam	154°C (310°F)
152	7.7	(3)	Co	Rubber, some foam	154°C (310°F)
152*	9.5	(3)	Co	Rubber	154°C (310°F)
158	1.5	(3)	Co	Rubber, foam	154°C (310°F)
159	1.5	(3)	Co	Cheesy, some foam	154°C (310°F)

*Material was heated @ 300°F briefly and remilled prior to application to the substrate.

Co = Cohesive break in sealant

Ad = Adhesive failure between sealant and substrate

LLCo = Low Level Cohesive - Light quantity of residual sealant left on substrate surface

(1) AJAX scrub, apply 1 percent solution A-187 silane in methanol, dry at R.T. 1 hour

(2) AJAX scrub only

(3) AJAX scrub, apply 1 percent solution A-1100 silane in methanol, dry at R.T. 1 hour

(4) Apply 10 percent solution of J-3 polymer after previous treatment, dry 16 hours at 300°F

TABLE 13. ADHESION IN PEEL PER MIL-S-8802D OF VARIOUS FORMULATIONS TO TITANIUM

Formulation	Average Peel Strength, pounds per inch width	Surface Preparation	Type of Failure	Sealant Visual Observations	Post Cure Temperature
127	2.5	(2)	LLCo	Gummy	177°C (350°F)
127	1.5	(1)	LLCo	Gummy	177°C (350°F)
126	1.9	(2)	LLCo	Rubber	177°C (350°F)
126	1.9	(3)	LLCo	Rubber	177°C (350°F)
142	3.5	(2)	20% Co 80% Ad	Rubber	177°C (350°F)
142	5.1	(3)	Co	Rubber	177°C (350°F)

Co = Cohesive break in sealant
 Ad = Adhesive break in sealant
 LLCo = Low Level Cohesive - Light quantity of residual sealant left on substrate surface
 (1) AJAX scrub, apply 1 percent solution A-187 silane in methanol, dry at R.T. 1 hour
 (2) AJAX scrub only
 (3) AJAX scrub, apply 1 percent solution A-1100 silane in methanol, dry at R.T. 1 hour

TABLE 14. ADHESION IN PEEL PER MIL-S-8802D OF VARIOUS FORMULATIONS AFTER FUEL IMMERSION

Formulation	152	152	152	156	156	156	149	158	159
Average Peel Strength, pounds per inch width	7.8	5.1 6.3	6.5 6.8	9.7 6.6	2.9 4.9	4.9 5.9	6.1	1.3	6.1
Surface Preparation	(1)	(1)	(1)	(2)	(2)	(2)	(3)	(1)	(1)
Substrate	Al	Al	Al	T ₁	T ₁	T ₁	Al	Al	Al
Type of Failure	Co	Co	Co	Co	Co	Co	Co	Co	Co
Sealant Visual Observations	Rubber	Rubber	Rubber	Rubber	Rubber	Rubber	Rubber, some foam	Rubber, foam	Rubber
Post Cure Temperature	154°C (310°F)	154°C (310°F)	154°C (310°F)	154°C (310°F)	154°C (310°F)	154°C (310°F)	154°C (310°F)	154°C (310°F)	154°C (310°F)
Fuel Immersion 60°C (140°F) - 7 Days	Control	JP-4	JRF	Control	JP-4	JRF	JRF	JRF	JRF

Al = Aluminum
T₁ = Titanium
Co = Cohesive

- (1) AJAX scrub, apply 1 percent solution A-1100 silane in methanol, dry at R.T. 1 hour
- (2) Pasa Gel for 2 hours, apply 1 percent solution A-1100 silane in methanol, dry at R.T. 1 hour
- (3) AJAX scrub, apply 1 percent solution A-187 silane in methanol, dry at R.T. 1 hour

The following generalizations apply to the adhesion to aluminum and titanium.

1. An adhesion promoter of some type was required either in the form of a primer or as an additive to the formula.
2. Epon 1001 is an effective additive with titanium if it is used at a low level to prevent degradation of performance properties and in conjunction with the A-1100 amino silane primer.
3. Initial use levels of silanes as additives made the compounded material hard or cheesy on cure. Reduced levels were evaluated.

The results were influenced partially by thermal degradation that had been noticed in several formula variations and are detailed in the thermal analysis section.

The following generalizations and conclusions can be made from the data in Tables 12 and 13:

1. The formula 145 used J-6 polymer that was aged longer at 177°C (350°F) before the addition of fillers. A test sample resulted that had 40 percent adhesive failure. Therefore, the late addition of fillers reduces the ability of the sealant to wet the surface and adhere.
2. The inclusion of A-1100 silane in formula 149, as opposed to 148, increased the peel strength. Therefore, the inclusion of silane as an adhesion promoter is advantageous if the level is low enough to prevent deterioration of other physical properties.
3. The comparison of 152 and 152* shows that removal of the methanol diluent from the silane reduces foam formation and increases peel strength. Additionally, it shows that A-187 silane is an acceptable adhesion promoter. A-187 silane is more desirable because it has a reactive epoxy group instead of the reactive amine in A-1100. This reactive amine may affect polymer stability and attack titanium substrates.
4. Formulas 158 and 159 show the adverse effect of foam caused by the methanol and the foam and cheesy appearance caused by the MD-1024 metal deactivator.

These same formulations were then evaluated for adhesion to titanium and aluminum substrates after exposure to JRF immersion. Results are given in Table 14. The peel strength of these formulations on either titanium or aluminum had not deteriorated as a result of immersion in JP-4 and JRF at 60°C (140°F) for 7 days. The average peel strength of all the samples as 5.8 pounds per linear inch.

The shear strength of the filleting sealant was determined per MIL-S-8802D. The specification requires a shear strength of not less than 200 psi. The shear strength is determined by pulling aluminum test panels coated with cured sealant in shear at a speed of 2 inches per minute. The average of 3 formulation 128 samples was 240 psi.

Lap shear strength of formulation 128 is reported in Table 15.

4.4.4 Tensile Strength and Elongation

Flow-out specimens 0.125 inch thick of the cured filleting sealant were prepared by pressing between two woven Teflon sheets and post-curing for 1 hour at 177°C (350°F). Tensile test specimens were cut from the flow-outs using a microtensile die. Three to four specimens of various filleting formulations were tested as: (1) controls, (b) after immersion for 14 days in JRF at 60°C (140°F), and (c) after immersion for 14 days in JP-4 jet fuel at 60°C (140°F). The immersion specimens were cooled for 24 hours at standard conditions and tested within 5 minutes after removal from the fluid.

The tensile strength and elongation tests are summarized in Table 16. The microtensile samples prepared are very notch-sensitive. Some of the values are low for tensile strength and exhibit high scatter. For example, in the formulation 156, they range from 101.9 to 151.4 psi with an average of 130.9 psi for the control. Formulation 152 is on the high side with values from 294.7 to 501.0 psi, with an average of 362.0 for the control. After immersion in JP-4 fuel, both formulations showed an increase in tensile strength, with the

TABLE 15. LAP SHEAR STRENGTH OF FORMULATION 128

Formula 128	Lap Shear Strength, psi	Mode of Failure
1	220	60 percent Cohesive - 40 percent Low-Level Cohesive
2	220	85 percent Cohesive - 15 percent Adhesive
3	280	100 percent Cohesive
	Average 240	

TABLE 16. TENSILE STRENGTH AND ELONGATION PER MIL-S-8802D OF VARIOUS FORMULATION AFTER FUEL AGING

Formula	152	152	152	153	153	153	156	156	156	160	160	160
Tensile Strength, psi	351.5	319.	439.6	306.6	291.6	343.8	151.4	163.5	168.6	174.5	259.3	371.6
	300.9	354.5	408.6	310.6	201.0	298.3	139.5	180.9	185.2	336.7	282.0	243.4
	294.7	368.5	384.7	283.7	277.8	275.7	101.9	158.8	210.2	326.4	313.8	330.9
	501.0			309.5						362.1		
Percent Elongation	89.0	81.0	88.0	159.0	167.0	174.0	106.0	77.0	80.0	40.0	94.0	100.0
	81.0	83.0	105.0	157.0	111.0	178.0	69.0	71.0	83.0	94.0	87.0	84.0
	70.0	84.0	99.0	139.0	159.0	186.0		75.0	78.0	86.0	96.0	101.0
	104.0			155.0						94.0		
Fuel Immersion 60°C (140°F) - 14 Days	Control	JRF	JP-4	Control	JRF	JP-4	Control	JRF	JP-4	Control	JRF	JP-4

average psi of 188.0 for 156 and an average of 411.0 psi for 152. The results are to be noted for their excellent fuel resistance in each of the four formulations tested. All the formulations, except 156, surpassed the specified tensile strength of 200 psi of MIL-S-8802D. Inclusion of A-187 silane at a higher level has clearly decreased the tensile strength of 156.

The percent elongation of all the samples was also low. Again, these low values can be attributed to the configuration of the specimens. The measurements were taken on a Chatillon Model UTSM Tester, which is designed for testing small samples. Visual examination of the dogbones revealed small breaks or cuts and non-uniform thicknesses in the samples.

The tensile and elongation properties of two formulations, 133 and 134, were determined and are

	<u>133</u>	<u>134</u>
Tensile Strength, psi	290	237
Percent Elongation	262	246

These formulations differ in that 133 has 50 percent more asbestos by weight, which indicates that the exact level of asbestos is not critical to ultimate strength and can be varied to control tack and flow of the uncured but compounded polymer.

4.4.5 Dynamic Mechanical Behavior

Dynamic mechanical behavior of the filleting sealant formulation 154 was evaluated on the Rheovibron. The results are shown in Figure 24. Rheovibron measurements were taken at 11 Hz from -65 to +200°C. From the tan δ curve, the Tg of the material was determined as -30°C. Some leveling of the curve is noted at approximately 0.15. Interpretation of this behavior indicates either a lightly crosslinked system or an uncrosslinked system of a very high molecular weight. The filleting sealant is a lightly crosslinked system by nature of its cure.

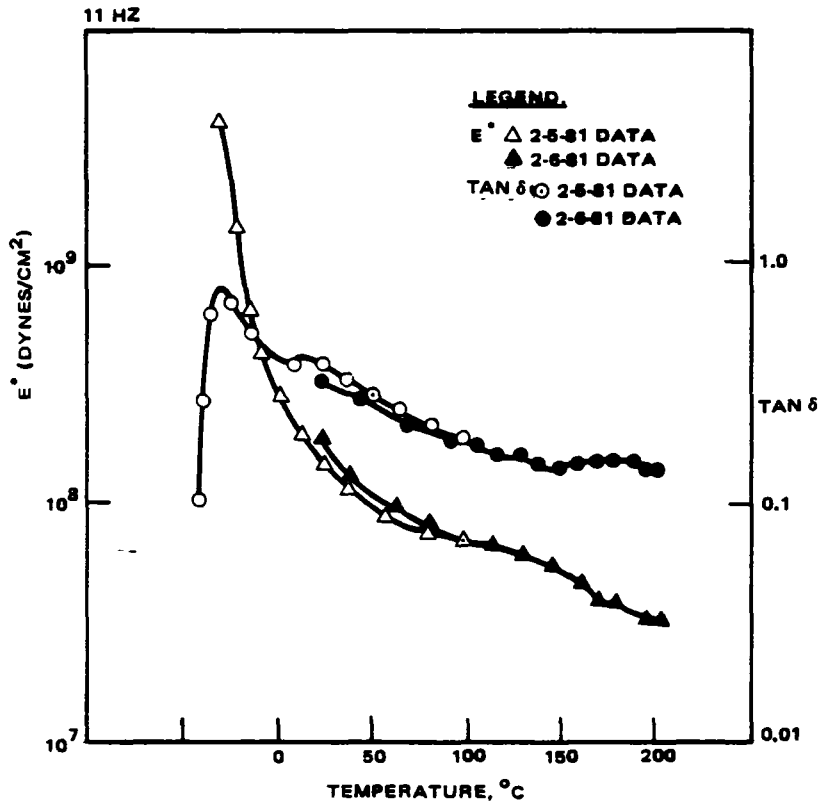

Figure 24. Dynamic mechanical behavior of formulation 154

4.4.6 Compression Set

Filleting seals in integral fuel tanks are relatively free of compressive stresses. However, knowledge of the performance of such a material under a constant deflection can aid in its formulation with respect to its elastic properties. Composition of the formulations tested for compression set is given in Table 17 in parts by weight.

Compression set results on the formulations 100,101, 104, 166, 172 and 173 are given in Table 18. The compression set data of 126 is given in Table 19 along with results of nitrile, neoprene and fluoroelastomer based materials used in O-ring applications. The results indicate that the present formula is similar to commercially available neoprene and nitrile based materials but is below the performance level of fluoroelastomer materials. Although compression set is not a critical property in a filleting sealant, an improvement in this property would be advantageous for other applications.

TABLE 17. FORMULATION COMPOSITION FOR COMPRESSION SET

Formulation	Polymer	Thermax	Asbestos	MD-1024	A-187
100	F-0 3.0	1.5			
101	F-0 3.0	1.5		0.12	
104	J-0 3.0	1.5			
126	J-3 5.0	4.0	0.24		
166	J-10 5.0	4.0	0.25		0.10
172	J-11 5.0	4.0	0.23		0.09
173	J-12 5.0	4.0	0.23		0.10

TABLE 18. COMPRESSION SET OF FILLETING SEALANT FORMULATIONS

Formulation	Test Temperature	Number of Hours	Percent Compression Set*
100	24°C (75°F)	24	0
100	82°C (180°F)	24	22
100	177°C (350°F)	24	67
101	24°C (75°F)	24	0
101	82°C (180°F)	24	0
101	177°C (350°F)	24	67
104	24°C (75°F)	24	0
104	82°C (180°F)	24	0
104	177°C (350°F)	24	100
166	24°C (75°F)	24	67
166	82°C (180°F)	5	81
172	24°C (75°F)	24	59
172	82°C (180°F)	5	90
173	24°C (75°F)	24	60
173	82°C (180°F)	5	90
*Average of three samples			

TABLE 19. PERCENT COMPRESSION SET OF FORMULA 126 IN
COMPARISON WITH OTHER ELASTOMER MATERIALS
AS A FUNCTION OF TEMPERATURE

Temperature	126	Nitrile*	Neoprene*	Fluoroelastomer*
50°C (122°F)	17	10	14	15
100°C (212°F)	29	24	25	16
150°C (302°F)	56	43	41	18
200°C (392°F)	100	100	100	22
250°C (482°F)	100	--	--	50

*The Precision O-ring Handbook (Precision Rubber Products Corporation, Lebanon, Tennessee, 1976)

4.5 FUEL RESISTANCE

In addition to the peel adhesion, tensile strength and elongation tests after immersion in JRF and JP-4, other solvent resistance data were gathered.

Resistance to swell by immersion in various organic and inorganic materials was evaluated. The selection of test solutions is based on the highly resistant fluorocarbon rubbers such as Viton. The results of formula 103 are given in Table 20; the corresponding data for Viton obtained from E. I. duPont de Nemours and Company are given in Table 21. The test solutions evaluated were some of those that most severely attack Viton. The results indicate that the perfluoroether polymer based material is much more resistant than Viton. Of the solutions tested, ammonia provided the only severe attack on formula 103. Formula 103 became soft and gummy after 2 days at room temperature, while Viton became hard and brittle. After 40 days of room temperature immersion of formula 103, the solvent resistance data did not change.

Fuel resistance was determined per MIL-S-81323 (WP) for formulation 166. The excellent resistance of this material to JRF is noted in Table 22. The samples were immersed in JRF for 25 days at 49°C (120°F) plus 60 hours at 71°C (160°F), plus 6 hours at 82°C (180°F). The volume change and weight change for three samples averaged -6.04 percent and 0.07 percent, respectively.

TABLE 20. SOLVENT RESISTANCE OF FORMULA 103

Solvent	Immersion Temperature	Percent Change in Weight				Percent Volume Increase			
		2 days	4 days	7 days	40 days	2 days	4 days	7 days	40 days
JP4	25°C (77°F)	---	---	0.7	no change	---	---	10.7	no change
	82°C (180°F)	0.9	---	---	---	2.5	---	---	---
Cyclopentanone	25°C (77°F)	1.9	1.9	---	---	0	0	---	---
	82°C (180°F)	-3.97	---	---	---	5.5	---	---	---
DC200	25°C (77°F)	---	---	0	no change	---	---	4.4	no change
	82°C (180°F)	0.15	---	---	---	1.7	---	---	---
H ₂ SO ₄ 30% Solution	25°C (77°F)	---	---	0	no change	---	---	0	no change
	82°C (180°F)	0.24	---	---	---	0	---	---	---
Ammonia	25°C (77°F)	3.8*	9.1	---	---	7.7*	7.7	---	---
	82°C (180°F)	Disintegrated		---	---	Disintegrated		---	---
JRF	25°C (77°F)	1.4	1.0	---	---	2.4	---	---	---
HAc 5%	25°C (77°F)	---	---	0	no change	---	---	3.6	no change
Benzene	25°C (77°F)	---	---	0.9	no change	---	---	0.5	no change
CCl ₄	25°C (77°F)	---	---	1.9	no change	---	---	7.7	no change
Ethyl Acetate	25°C (77°F)	2.5	2.5	---	---	0	39.6	---	---
Acetone	25°C (77°F)	1.5	1.9	---	---	0.19	0.19	---	---
Ethyl Ether	25°C (77°F)	2.2	2.0	---	---	28.0	29.7	---	---
Pyridine	25°C (77°F)	0.9	0.14	---	---	3.6	3.6	---	---

*Softened

TABLE 21. SOLVENT RESISTANCE OF VITON

Solvent	Immersion Temperature	Time, days	Percent Volume Increase
JP4	25°C (77°F)	28	1.6
DC 200	177°C (350°F)	28	-28.0
H ₂ SO ₄	boiling	28	0.5
Ammonia	25°C (77°F)	1	Fused and hardened
Acetic Acid Glacial	24°C (75°F)	7	62
Ethyl Acetate	25°C (77°F)	1	280
Acetone	25°C (77°F)	1	200
Ethyl Ether	25°C (77°F)	3	97
Pyridine	25°C (77°F)	3	120

TABLE 22. FUEL RESISTANCE OF FORMULATION 166

Sample	Percent Change in Weight	Percent Change in Volume
A	0.11	-6.39
B	0.04	-8.48
C	0.06	-3.26

4.6 THERMAL EVALUATION

The filleting sealant polymerizations were followed by thermogravimetric analysis to determine thermal stability and extent of cure. Standard TGAs of the J-series polymers (J denotes filleting sealant polymers) were run in air at 20°C/min to observe the onset of degradation temperature (Figure 25).

<u>Polymer</u>	<u>Onset of Degradation, °C</u>
J-5	300
J-10	340
J-11	310
J-12	300

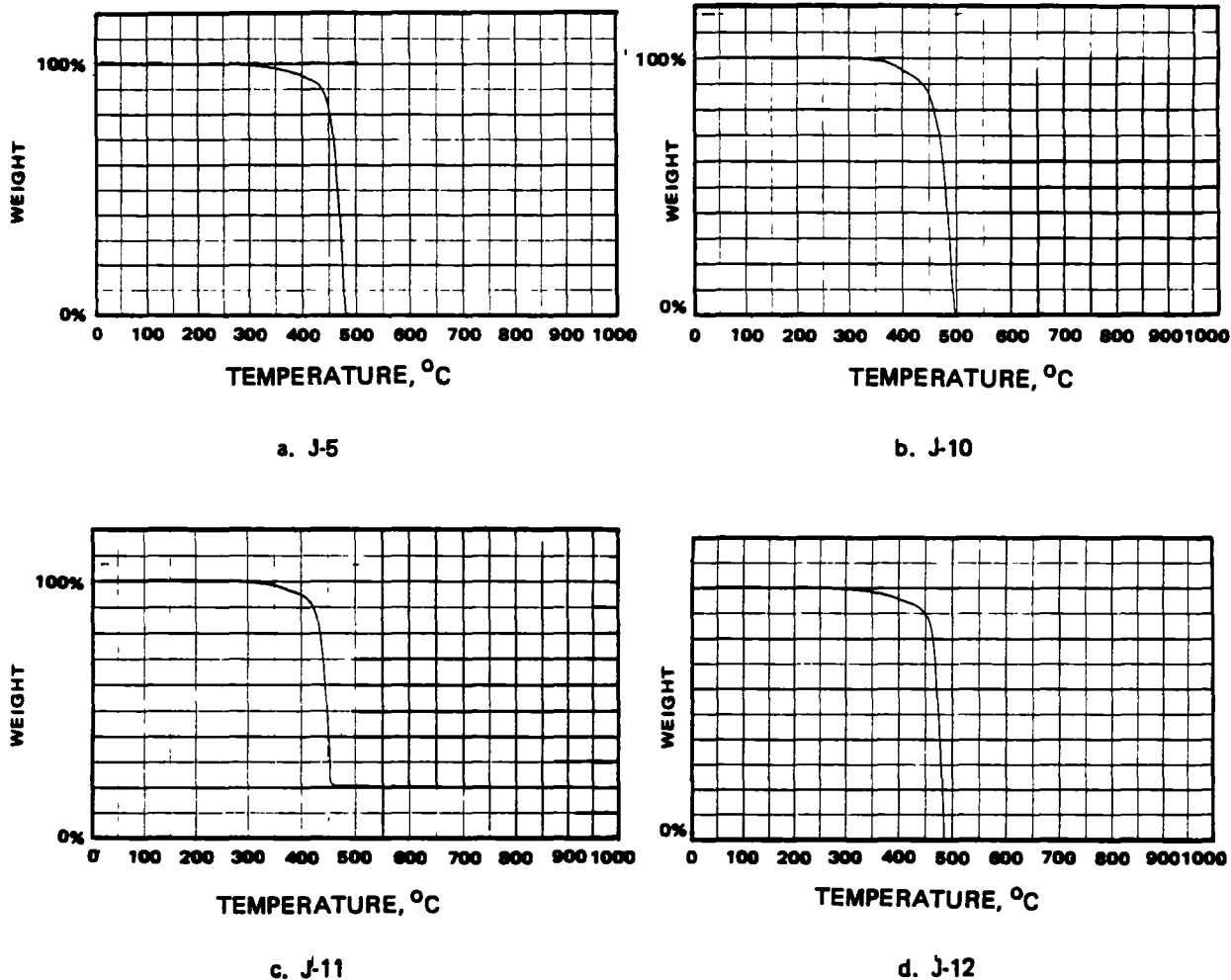
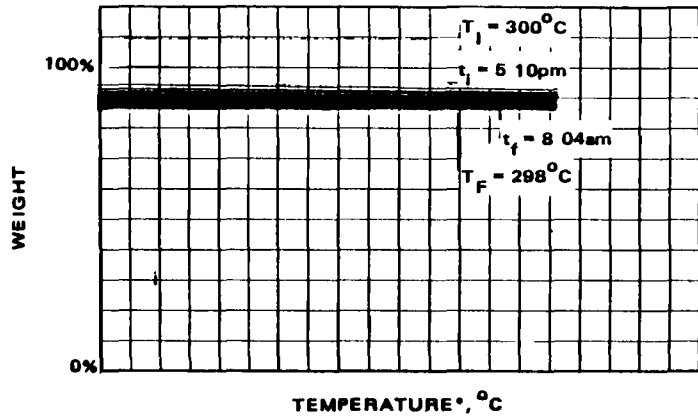

Figure 25. TGAs for J-series polymers

The TGAs of the formulations derived from some of the J-polymers were also run in air. See Figures 38, 39 and 40. The isothermal TGAs are shown in Figure 26.

<u>Formulation</u>	<u>Polymer</u>	<u>Onset of Degradation, °C</u>	<u>Percent Weight Loss 300°C, 15 hrs</u>
152	J-5	300	14
166	J-10	310	27
173	J-12	260	20

The filleting sealant polymerizations are more reproducible and consistently achieve at least 300°C thermal stability. Observation of handling characteristics must be used as a guideline since addition of fillers to the completely cured polymer is difficult. When the fillers are not totally incorporated



a Formulation 152

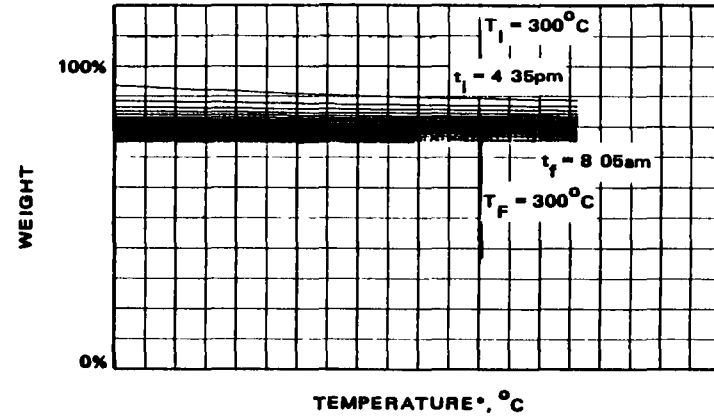

b Formulation 166

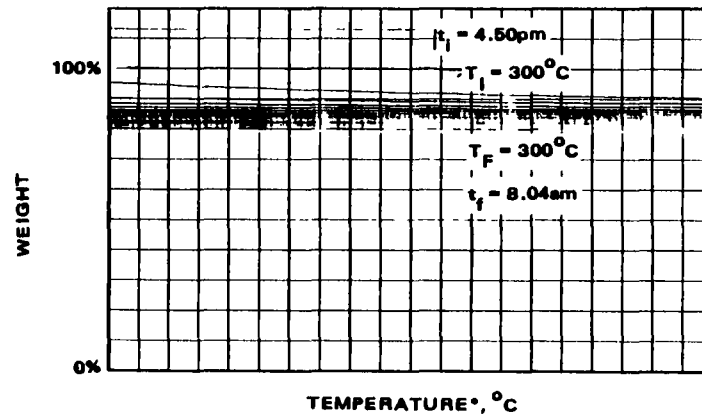

c Formulation 173

Figure 26. Isothermal TGAs for formulations used in thermal evaluation

into the polymer, as in formulation 145, greater adhesive failure occurred. A similar observation was made on formulation 148, which used J-7 polymer that was aged one additional day at 177°C (350°F) before the addition of fillers. TGA (Figure 27) analysis confirms that late addition of fillers does not affect thermal properties, but as mentioned earlier, only adhesion properties. The weight loss at 300°C after 15 hours is only 8 percent.

The glass transition temperature (T_g) of formula 148 was determined by thermomechanical analysis. The T_g was found to be -40°C (Figure 28). The T_g of formulation 154, as determined by evaluating the dynamic modulus on the Rheovibron, was from the $\tan \delta$ curve -30°C.

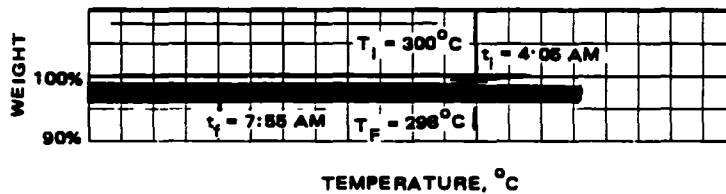

Figure 27. Isothermal TGA of formulation 148

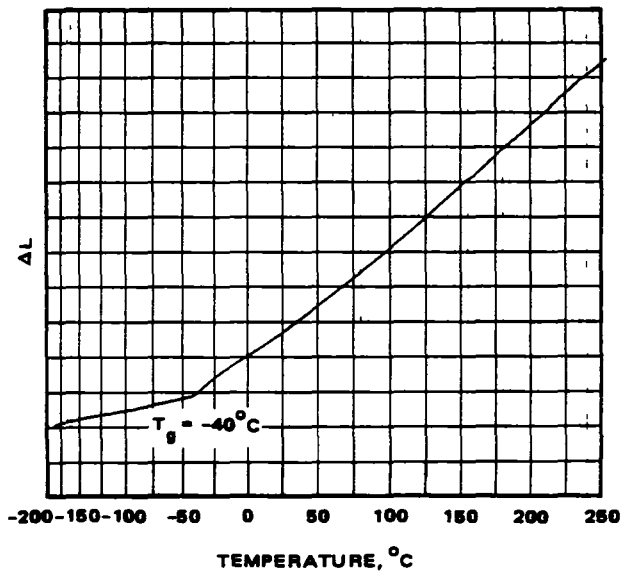

Figure 28. Thermomechanical analysis of formulation 148

4.7 OTHER APPLICATIONS

4.7.1 Molding of O-Rings

The filleting sealant polymer, which has shown excellent thermal stability and fuel resistance, can be utilized in other applications. The moldings of O-rings was therefore investigated. Formulations 166, 172 and 173 were used in the following procedure.

The mold was treated with RAM 225, a mold release, and baked at 177°C (350°F) for 1 hour. Then the mold was packed with the polymer wrapped with fiberglass for insulation and placed in a platen press preheated to 177°C (350°F). Pressure was applied very slowly so that the material could flow but not totally extrude out of the mold. Pressure of about 1/2 ton was then kept on the mold for 1 to 2 hours. The mold was cooled below 93°C (200°F) and the O-ring removed. The O-rings formed were springy and rubbery.

4.7.2 Foam

In formulating filleting sealant, it was noted that the presence of solvent as in the addition A-187 silane diluted with methanol caused foam formation. Thus, foam products might be able to be prepared in closed molds. One potential application is a fire resistant foam for aviation seat cushions.

4.7.3 Rubber Toughened Polyimides

Preliminary experiments at Hughes have shown that perfluoroalkylene-ether oligomers can be copolymerized with thermosetting polyimide prepolymers to yield polyimides containing flexible segments within the polymer backbone. Specific materials reacted to date have included Hughes/Gulf Thermid 600 polyimide and a hydrogenated polyperfluoroalkyleneoxide dinitrile, developed at the NASA-Ames Research Center. Both Thermid 600 and the polyperfluoroalkylene-ether materials have exceptional temperature capabilities (long-term use at temperatures exceeding 300°C (572°F)). Incorporation of one NASA material, the polyperfluoroalkyleneether diamidoxime prepolymer, into the polyimide is suggested as another analogous approach to flexibilize the high temperature resin.

Such chemical combination of a polyimide with the NASA polyperfluoroalkyleneoxide oligomers probably can yield a family of copolymers with the following characteristics:

1. High degree of toughness
2. Continuous performance at 300°C (572°F)
3. Complete fire retardancy
4. Improved processability as an adhesive, laminating resin, or coating
5. Tailorable strain capability, controlled by the proportion of polyimide to elastomer in the polymer backbone.

The cyano-terminated polyperfluoroalkyleneoxide is hydrogenated and then reacted directly with the anhydride precursor material to yield a polyimide with flexible segments in the polymer backbone. The flexibilizing agent is thus distributed on a molecular level and is not incorporated as a discontinuous mixture. The polyperfluoroalkyleneoxidediamine probably could be substituted for any desired proportion of the stoichiometric mixture of diamine normally used to provide tailorable degrees of toughening.

The chemistry is described below:

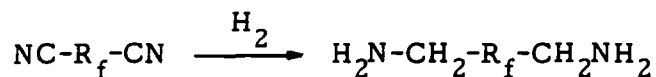

where

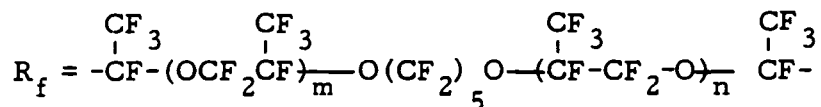

and

$$m + n = 6$$

Compound I is reacted along with standard amines and a dianhydride to form first the amic acid and then the imide

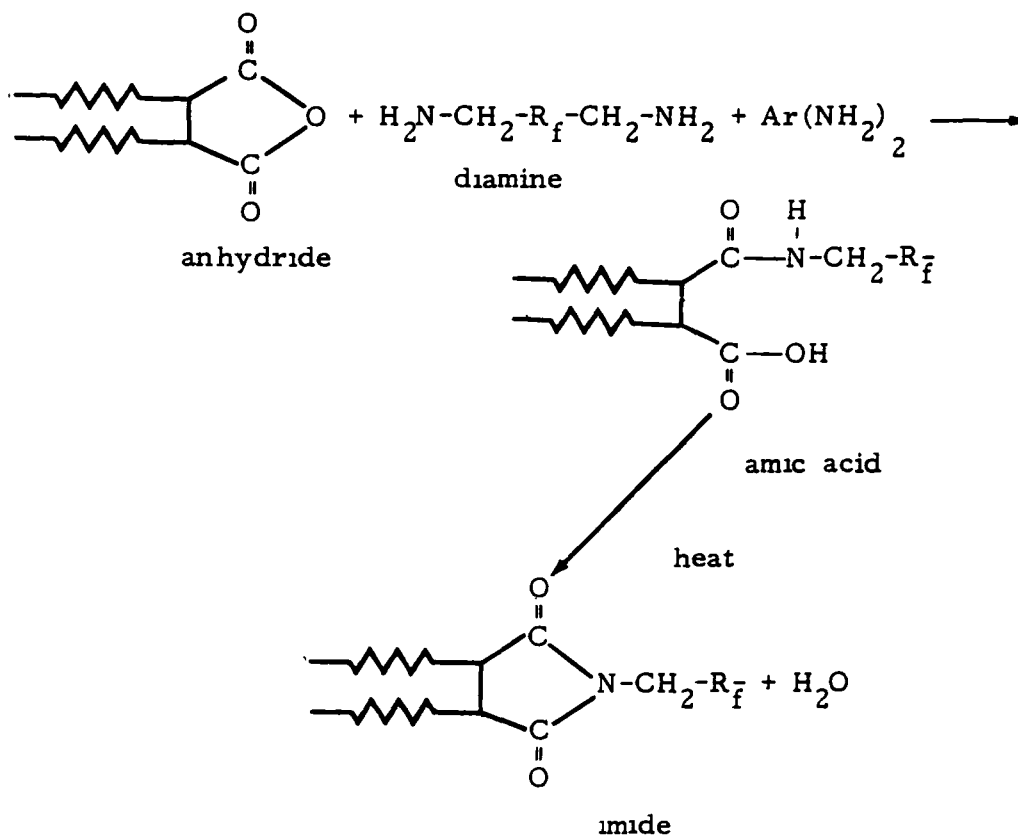

The prepolymer formed by the penultimate reaction above (before the final thermally induced cure) is in liquid form at room temperature. This key feature contributes to the belief that this system should be highly processable as an adhesive or laminating resin. The elastomeric nature of the material should also contribute to improved processability. In preliminary experiments, it was noted that the liquid prepolymer cured in the form of a tough film which adhered tenaciously to a glass plate. The peeled film when subjected to a direct flame did not burn. Additionally, a stratification phenomenon was noted in which one surface of the film was completely hydrophobic while the other side was hydrophilic. It is theorized that the fluorinated portion of the polymer is oriented in one direction and the polyimide in the other. Further work will be required to elucidate the mechanism of reaction.

Possible applications of this system include:

1. A fire retardant film
2. A high-temperature adhesive
3. A laminating resin for fiber reinforced composites
4. A high-temperature sprayable coating
5. A moisture resistant polyimide.

5.0 PRELIMINARY EVALUATION OF TRIAZINE POLYMER AS SEALANT

Previously it has been shown (Reference 2) that high molecular weight perfluoroalkylether triazine elastomer exhibits thermal and oxidative stability. Therefore, it is a potentially useful material in applications such as high temperature seals, O-rings and other uses. Some preliminary formulation was undertaken to evaluate to some extent the triazine polymer as a fuel tank sealant.

5.1 POLYMERIZATION

The perfluoroalkylethertriazine, as received, was a milky, viscous material of unknown molecular weight. A standard TGA (in air, 20°C/min) was run to determine the extent of cure of the received prepolymer (Figure 29). The prepolymer showed onset of degradation at 175°C. The cure schedule of heating for 15 hours at 154°C (310°F), then three additional hours at 154°C (310°F), and finally for a total of 30 hours at 154°C (310°F) advanced the polymer in thermal stability to 260°C for the onset of degradation temperature (Figure 30).

Another sample was then cured for 4 days at 154°C (310°F). The cure schedule as worked out at the present does not produce the same thermal stability as the literature values. Polymerization of the triazine prepolymer needs more investigation.

5.2 FORMULATION

The perfluoroalkylethertriazine was formulated as a filleting sealant. A small amount of the polymer as received was milled as follows in parts by weight:

CH 327 polymer	2.00
Thermax	1.60
Asbestos RG-244	0.10

This formulation was denoted 168.

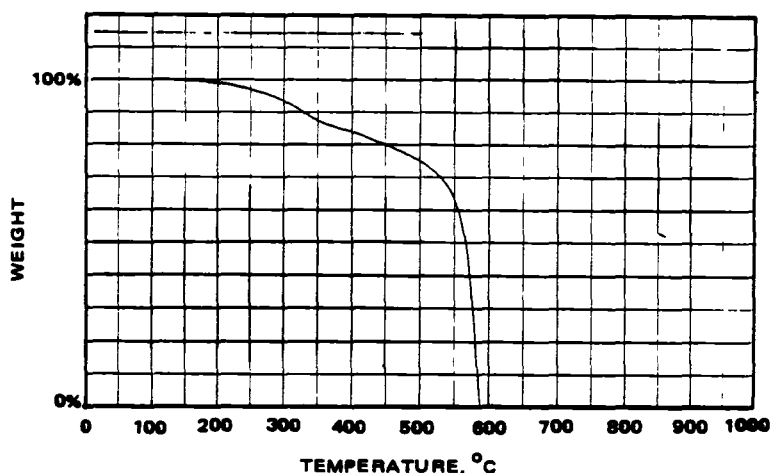

Figure 29. TGA of uncured triazine polymer, CH 327

Milling of the components resulted in a sticky, soft and pliable mass. The TGA of formulation 168 is shown in Figure 31a. After milling, the formulation was heated at 154°C (310°F) for 24 hours. The TGA of the triazine after aging is shown in Figure 31b. The degradation temperature was advanced 50 degrees to 250°C by the post-cure, indicating that crosslinking was not inhibited by the early addition of fillers.

A previously received sample of cured polymer from NASA, which had been milled with the same levels of fillers, shows a degradation temperature of 290°C (Figure 32). Formulation 171, where the CH 327 polymer was cured at 154°C (310°F) for 4 days was difficult to mill. Triazine polymer formulations are listed in Table 23.

5.3 THERMAL EVALUATION

The triazine polymer as formulated in sample 204.2 shows an excellent thermal stability when heated at 300°C in air for 15 hours. The weight loss at those conditions is no more than 5 percent (Figure 33). Formulation 168, as

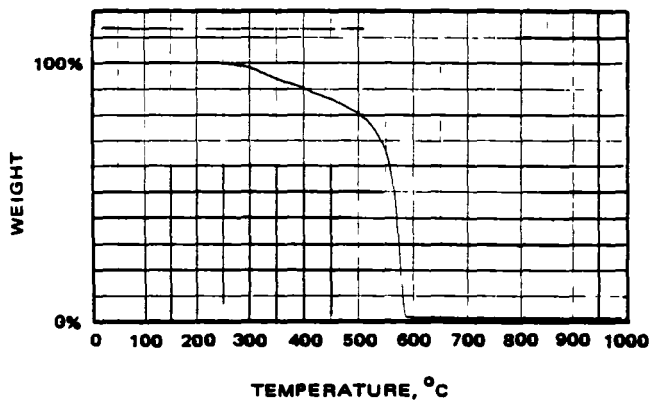

a. Cured 12 hours at 154°C (310°F)

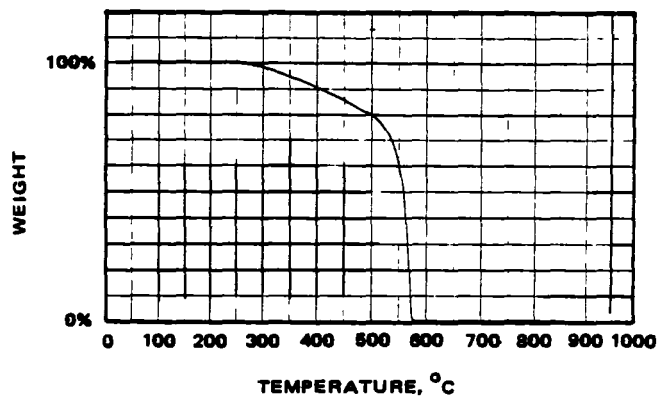

b. Cured 18 hours at 154°C (310°F)

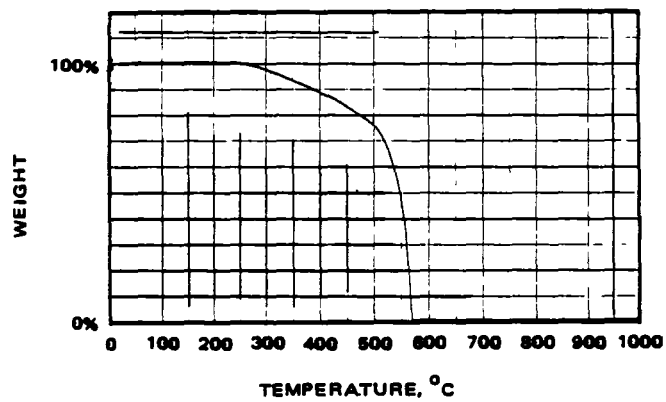

c. Cured 30 hours at 154°C (310°F)

Figure 30. TGA of triazine prepolymer CH 327

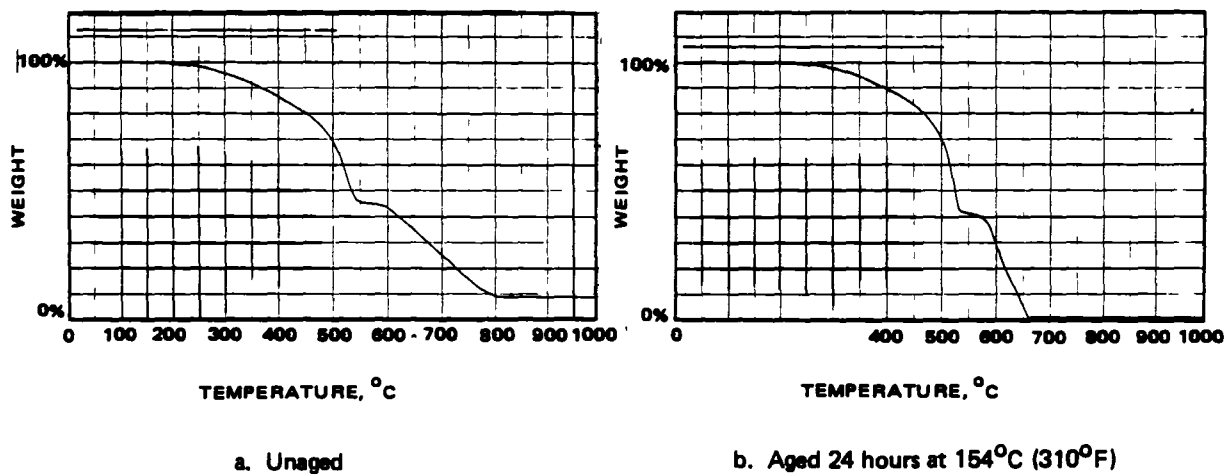

Figure 31. TGA of formulation 168

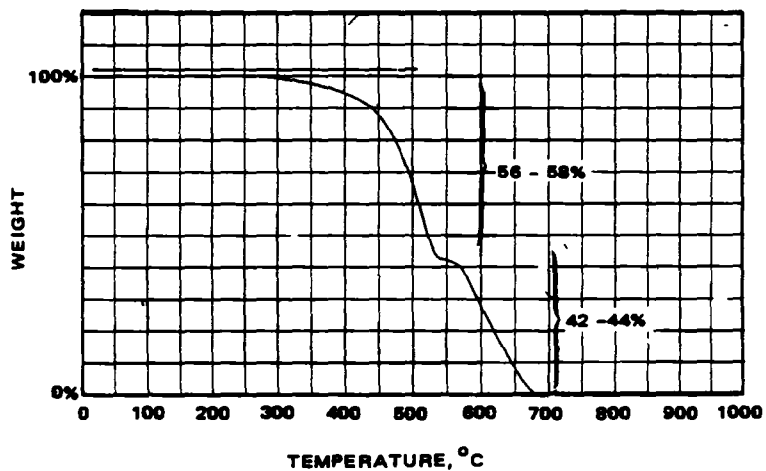

Figure 32. TGA of formulated triazine polymer CH 204.2

TABLE 23. TRIAZINE POLYMER FORMULATIONS

Formulation	Polymer	Weight	Thermax	Asbestos
204.1	CH204	1.0	0.81	0.05
204.2	CH204	1.0	0.80	0.05
168	CH327	1.0	0.80	0.05
171	CH327	1.0	0.80	0.05

previously mentioned, did not reach the same level of thermal stability. Formulation 171 with a different cure schedule from 168 shows an onset of degradation temperature of 230°C (Figure 34) and an isothermal TGA (Figure 35) shows 25 percent weight loss. The characteristic TGA (in air, 20°C/min) of the triazine sample 204.2 shows a second inflection point at 540°C after a weight loss of 56 to 58 percent, with a total weight loss occurring at 680°C. The reason for this behavior is unknown at this time; however, Thermax may be incompatible with the triazine polymer.

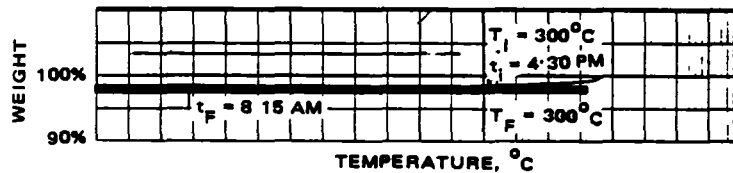

Figure 33. Isothermal TGA of formulated triazine polymer CH 204.2

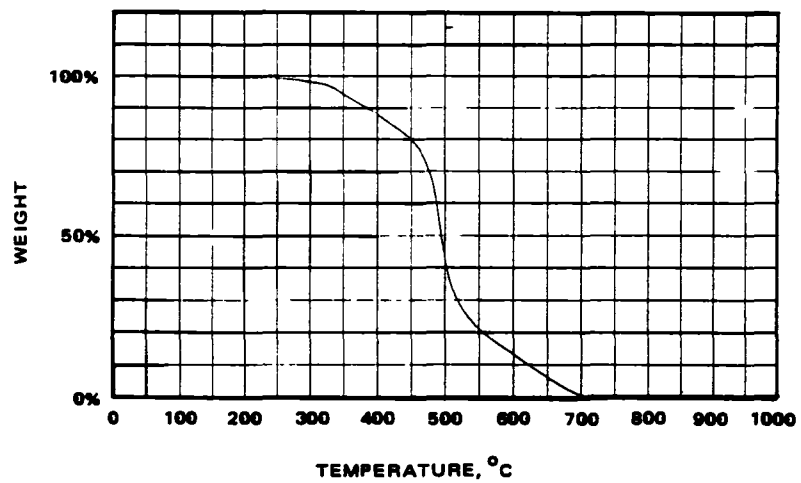

Figure 34. TGA of formulation 171

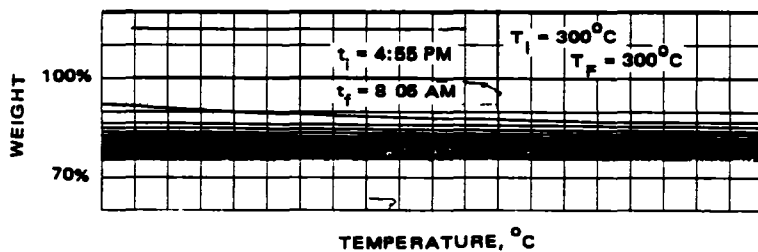

Figure 35. Isothermal TGA of formulation 171

6.0 RECOMMENDATIONS FOR FUTURE WORK

The previous sections have covered the successful development of channel and filleting sealants from cyano- and diamidoxime-terminated perfluoroalkyleneether prepolymers that were supplied by NASA. Preliminary specifications were prepared. Additional work is recommended to more fully define these materials and their processing requirements. Techniques for process scale-up need to be developed. Specifically, the following areas should be studied:

1. Further development of the polymerization cycles of the prepolymers is necessary to eliminate batch-to-batch variations that have been noted.
2. Scale-up polymerization parameters of the prepolymers need to be defined.
3. Further experimentation in choice of fillers used for the triazine sealant formulation is necessary since some indication exists of instability past 500°C.
4. For safety considerations, a substitute for asbestos as a thixotropic and reinforcement filler should be investigated.
5. Investigation of formulations for various applications such as foam formulation, O-rings and coatings should be made.

This Page Intentionally Left Blank

7.0 REFERENCES

1. D. P. Salisbury and R. H. Johnson, "Studies of New Perfluoroether Elastomeric Sealants," Summary Report, FR-80-70-1191 (Contract NAS 2-10334), October 1979-September 1980.
2. R. W. Rosser and R. A. Korus, Journal of Polymer Science: Polymer Letters Edition, Vol. 18, 135-139 (1980).

APPENDIX
SPECIFICATIONS

FILLETING SEALANT SPECIFICATION

1. Scope

1.1 Scope. This specification establishes the requirements for a high temperature resistant fuel tank filleting sealing compound for sealing integral fuel tanks and mold lines. The sealant is capable of withstanding long term exposure from -54° to 177°C (-65° to 350°F) short term exposure at 4-hour intervals or less to 288°C (550°F).

1.2 Classification. The sealing compound shall be of the following class.

Class A - Sealing material, suitable for application by spatula.

2. Applicable Documents

2.1 Government documents. The following documents form a part of this specification to the extent specified herein. In the event of conflict between the documents referenced herein and the contents of this specification, the contents of this specification shall be considered a superseding requirement.

Specifications

Federal

QQ-A-250/4	Aluminum Alloy 2024, Plate and Sheet
QQ-A-250/13, T ₆	Aluminum Alloy
TT-E-751	Ethyl Acetate, Technical (Organic Coatings Use)
TT-M-261	Methyl-Ethyl-Ketone. (For use in organic coating)
TT-S-735, Type I	Standard Test Fluids, Hydrocarbon
TT-T-548	Toluene; Technical

Military

MIL-T-9046	Titanium Alloy
MIL-F-5566	Fluid; Anti-icing (Isopropyl alcohol)

3. Requirements

3.1 Qualification. The sealing compound furnished under this specification shall be a product which has been tested, and has passed the qualification tests specified herein, and has been listed or approved for listing on the applicable Qualified Products List.

3.2 Materials. The basic ingredient used in the manufacture of the sealing compound shall be synthetic rubber of the poly(perfluoroalkyleneetheroadiazole) type. The sealing compound shall be cured, formulated and postcured prior to application. The cured compound will be black in color.

3.2.1 Preparation of Sealant

3.2.1.1 Polymerization. The filleting sealant shall be prepared from 30.0 grams of perfluoroalkyletherdiamidoxime (NASA Ames) and 24.0 grams of perfluoroalkyleneetherdinitrile (NASA Ames). The two components shall be mixed in a pyrex dish 20.3 x 20.3 x 5.1 cm (8 x 8 x 12 inches) and cured in a convection oven according to the following schedule:

- a. 6 hours at 127°C (260°F) - stir intermittently
- b. 63 hours at 154°C (310°F)
- c. 26 hours at 177°C (350°F)

The polymer prior to milling shall exhibit by thermogravimetric analysis (in air at 20°C/minute) an onset of degradation temperature of 300°C or higher and by isothermal gravimetric analysis a weight loss no greater than 5 percent at 300°C in air for 15 hours.

3.2.1.2 Milling. The milling operation shall be performed in a drybox so that asbestos contamination will not occur as per OSHA regulations. Filler level of the sealant is given in parts by weight.

Polymer (3.2.1.1)	100
Carbon black (Thermax, R.T. Vanderbilt)	8.0
Asbestos (RC-244 "Calhdria", Union Carbide)	0.50
Coupling agent (A-187, Union Carbide)	0.20

The fillers shall be milled for at least 30 minutes and until the appearance of the material indicates complete and uniform dispersion. The asbestos shall be

milled in first, followed by the carbon black and the coupling agent. Post cure the material for 1 hour at 154°C (310°F).

3.2.2 Appearance. The sealing compound shall be of a uniform blend. There shall be no separation of ingredients.

3.3 Physical Properties

3.3.1 Specific gravity. When tested in accordance with 4.6.1, the specific gravity of the cured sealing compound shall be not more than 1.90 at standard conditions.

3.3.2 Nonvolatile content. When tested in accordance with 4.6.2, the nonvolatile content of the freshly cured compound shall be not less than 98 percent.

3.3.3 Viscosity of base compound. The sealing compound shall be applicable by spatula.

3.3.4 Flow. The cured sealing compound shall exhibit no flow.

3.3.5 Application Time. There shall be no limit to application time.

3.3.6 Work Life. The sealing compound shall exhibit no limit to work life.

3.3.7 Standard curing rate. After application a postcure at 154°C (310°F) for one hour is recommended.

3.3.8 Low-temperature flexibility. When tested in accordance with 4.6.7 the sealing compound shall withstand the low temperature flexibility test at $-54 \pm 1^\circ\text{C}$ ($65 \text{ F} \pm 2^\circ\text{F}$) with very little cracking or loss of adhesion.

3.3.9 Peel strength. When tested in accordance with 4.6.8, the sealing compound shall have a minimum peel strength of 5.0 pounds. The material shall exhibit 100 percent cohesive failure, except for bubbles, knife cuts, and other causes that are obviously not the fault of the sealing compound.

3.3.10 Shear strength. The shear strength of the cured sealing compound shall be not less than 200 psi when tested as specified in 4.6.5. At least 75 percent of the area of separation produced in the shear test specimens shall be within the sealing compound.

3.3.11 Stress corrosion. When tested in accordance with 4.6.6 there shall be no corrosion under the sealing compound.

3.3.12 Resistance of fuel.

3.3.12.1 Weight loss and volume change. When tested in accordance with 4.6.3, the percentage change in weight shall be no more than ± 0.20 percent, and the percentage change in volume shall be no greater than ± 10 percent. At no time shall the sealing compound show signs of cracks, powdering, hardening or loss of adhesion.

3.3.12.2 Tensile strength and elongation. When the sealing compound is tested in accordance with 4.6.9, the ultimate tensile strength and elongation of the cured compound shall be not less than 300 psi and 180 percent.

3.4 Thermal stability. The sealing compound shall exhibit a weight loss no greater than 15 percent when tested in accordance with 4.6.10.

4. Quality Assurance Provisions.

4.1 Responsibility for inspection. Unless otherwise specified in the contract or purchase order, the supplier is responsible for the performance of all inspection requirements as specified herein. Except as otherwise specified, the supplier may utilize his own facilities or any commercial laboratory acceptable to the Government. The Government reserves the right to perform any of the inspections set forth in the specification where such inspections are deemed necessary to assure supplies and services conform to prescribed requirements.

4.2 Classification of tests. The inspection and testing of the sealing compound shall be classified as follows:

- a. Qualification tests (4.3)
- b. Quality conformance inspection (4.4)

4.3 Qualification tests. The material submitted for qualification must meet all the requirements for this specification.

4.3.1 Qualification test samples. The qualification test samples shall consist of 200 grams of the compound upon which qualification is desired.

4.4 Quality conformance inspection.

4.4.1 Lot. A lot shall consist of a batch of all the sealing compound manufactured from the same components processed at the same time.

4.4.2 Sampling for quality conformance tests. A sample, sufficient in size for test purposes, shall be selected at random from the lot and subjected to the lot acceptance tests of Table I.

4.4.3 Quality conformance tests. Quality conformance tests for acceptance of individual batches shall consist of the following tests:

TABLE I. LOT ACCEPTANCE TESTS

Test	Requirement Paragraph	Test Paragraph	Number of Determinations Required
Nonvolatile content	3.3.2	4.6.2	2
Fuel Resistance	3.3.13	4.6.3	2
Adhesion	3.3.9	4.6.8	3
Thermal Stability	3.4	4.6.10	1

4.5 Test conditions. Unless otherwise specified, tests shall be conducted at a temperature of $25 \pm 1^{\circ}\text{C}$ ($77 \pm 2^{\circ}\text{F}$) and a relative humidity of 50 ± 5 percent.

4.5.1 Tolerances on environmental conditions. Unless otherwise specified, tolerances on environmental conditions shall be as follows:

- a. Days ± 4 hours
- b. Hours ± 1 hour
- c. Minutes ± 4 minutes

4.5.2 Preparation of test panels and fixtures.

4.5.2.1 Preliminary cleaning. Gross soil, marking ink, or grease pencil, if present, shall be removed by scrubbing with cheesecloth wet with methyl-ethyl-ketone conforming to TT-M-261.

4.5.2.2 Cleaning. All surfaces to which the sealing compound will be applied shall be cleaned by scrubbing and rinsing in solvent formulated in accordance with Table II.

TABLE II. FORMULATION OF CLEANER

Ingredient	Specification	Percent by Volume
Aromatic petroleum naphtha	TT-N-97, Type I, Grade B	50
Ethyl acetate	TT-E-751	20
Methyl ethyl ketone	TT-M-261	20
Isopropyl alcohol	MIL-F-5566	10

After rinsing and while still wet, the test surface shall be wiped dry with clean cheesecloth. (The cheesecloth shall be free of lint and starch and shall contain no dye, rust, oil, or other foreign material.)

4.5.3 Primer. When specified, a primer shall be applied after the surfaces have been prepared in accordance with 4.5.2. The primer shall be applied in accordance manufacturer's instructions.

4.5.4 Recleaning. Recleaning, when required after 4.5.3, shall be in accordance with 4.5.2.2.

4.5 Test methods.

4.6.1 Specific gravity. The specific gravity shall be determined on the test panels prepared for the fuel resistance test (4.6.3.2). The panels before and after the application of the sealing compound shall be weighed accurately ± 0.001 grams, in air and distilled water at $25 \pm 1^\circ\text{C}$ ($77 \pm 2^\circ\text{F}$). The specific gravity shall be determined in triplicate and determined by the following calculations.

$$\text{Specific Gravity} = \frac{W_1 - W_3}{(W_1 + W_4) - (W_2 + W_3)}$$

W_1 = Weight of panel in air

W_2 = Weight of panel in water.

W_3 = Weight of panel and sealing compound in air.

W_4 = Weight of panel and sealing compound in water.

4.6.2 Nonvolatile content. Five to ten grams of sealing compound shall be transferred to a tared covered cup approximately three inches in diameter and 3/4 inch in depth. The specimen shall be weighed to the nearest milligram and the weight of the sealing compound calculated. The cover shall then be removed and the sealing compound heated for 7 days at 70 ±1°C (158 ±2°F). It shall then be cooled in a dessicator at standard conditions, the cover replaced, and the specimen weighed. The test shall be run in duplicate and the average of the results reported. The percentage of the total nonvolatile content shall be calculated as follows:

$$\text{Percentage nonvolatile content} = \frac{\text{First weight}}{\text{Initial weight}} \times 100$$

4.6.3 Fuel resistance.

4.6.3.1 Formulation of jet reference fluid. The jet reference fluid required for conducting the fuel resistance test and fluid immersion tests of this specification shall be formulated as follows:

Toluene (TT-T-548)	30 Volumes
Cyclohexane (Technical Grade)	60 Volumes
Iso-octane (TT-S-735, Type I)	10 Volumes
Tertiary butyl disulfide (doctor sweet)	1 Volume
Tertiary butyl mercaptan	0.015 ±0.0015 weight percent of other four components.

4.6.3.1.1 Jet reference fluid tests. The mercaptan sulfur content when tested in accordance with Method 5206 of FED-STD-791 shall be 0.0050 ±0.0005 weight percent of the jet fluid. The total sulfur content when tested in accordance with Method 5201 of FED-STD-791 shall be 0.400 ±0.005 weight percent of the jet fluid.

4.6.3.1.2 The fluid should be stored out of contact with light in containers which are inert to the fluid ingredients. (Welded aluminum, nongalvanized welded steel, or glass containers are suitable.) Fluid older than 90 days shall be retested for mercaptan and total sulfur content.

4.6.3.2 Test Procedure. Three panels, 0.081 x 5.1 x 5.7 cm (0.032 by 2 by 2.25 inches) of aluminum conforming to QQ-A-250/4, shall be tared accurately

(±0.001 gram) in air (W_1) and in water (W_2). A pad of sealing compound 0.15 by 5.1 by 5.1 cm (0.06 by 2 by 2 inches) shall be applied to each of the panels. One-quarter inch along one edge shall not be coated for handling purposes. The volume of the specimens shall be determined by weighing in air (W_3) and in water (W_4). The specimens shall be immersed in jet reference fluid for 25 days at $49 \pm 1^\circ\text{C}$ ($120 \pm 2^\circ\text{F}$), plus 60 hours at $71 \pm 1^\circ\text{C}$ ($160 \pm 2^\circ\text{F}$), plus 6 hours at $82 \pm 1^\circ\text{C}$ ($180 \pm 2^\circ\text{F}$). The volume of the specimens shall be determined immediately upon removal from the fuel by weighing in air (W_5) and in water (W_6). The percent change in volume shall be determined by the following formula and the average of the three specimens reported to the nearest percent.

$$\frac{(W_3 + W_6) - (W_4 + W_5)}{(W_1 + W_4) - (W_2 + W_3)} \times 100 = \text{percent change in volume}$$

Each specimen shall then be placed in a $93 \pm 1^\circ\text{C}$ ($200 \pm 2^\circ\text{F}$) oven for 24 hours, cooled to room temperature, and then weighed again (W_7). The percent weight change shall be determined by the following formula and the average of the three specimens reported to the nearest 0.1 percent.

$$\frac{W_3 - W_7}{W_3 - W_1} \times 100 = \text{percent weight change}$$

The specimens shall be inspected for evidence of hardening, cracking, powdering, or loss of adhesion.

4.6.5 Adhesion. Six 0.10 x 2.54 x 10.2 cm (0.040 by 1 by 4 inch) aluminum panels conforming to QQ-A-250/4 shall be cleaned and prepared as specified in Paragraph 4.5.3. Then Ajax scrub, apply 1 percent solution A-187 silane in methanol, dry at room temperature for 1 hour. Place a ball of sealing compound approximately 3/4 inch in diameter in the center of a one square inch section at the end of three panels. Place another panel directly over the lower panel and compress evenly to leave approximately 0.15 cm (0.060 inch) space separating the faying surfaces. Remove excess sealing compound and post-cure in an oven at 154°C (310°F) for one hour.

Condition the three specimens 24 hours at $25 \pm 1^\circ\text{C}$ ($77 \pm 2^\circ\text{F}$) and 50 ± 5 percent relative humidity. Peel the panels apart at a slow steady rate and examine the surfaces for conformance to 3.8. The test shall be performed in triplicate and the average of the results reported.

4.6.6 Stress corrosion. Six $0.10 \times 2.54 \times 10.2$ cm (0.040 by 1 by 4 inch) titanium (6 Al-4V) coupons shall be cleaned and prepared as specified in 4.5.3. Then the coupons shall be treated for 2 hours with Pasa-Gel and primed with a 1 percent solution of A-187 silane in methanol. These six panels then shall be placed in a stress corrosion fixture as shown in Figure 1.

The fixture with the test coupons shall be placed in an oven at 288°C (550°F) and heated for 500 hours or until the sealant disintegrates (no less than 160 hours). The titanium metal surfaces shall be inspected under the sealant for stress cracks and damage.

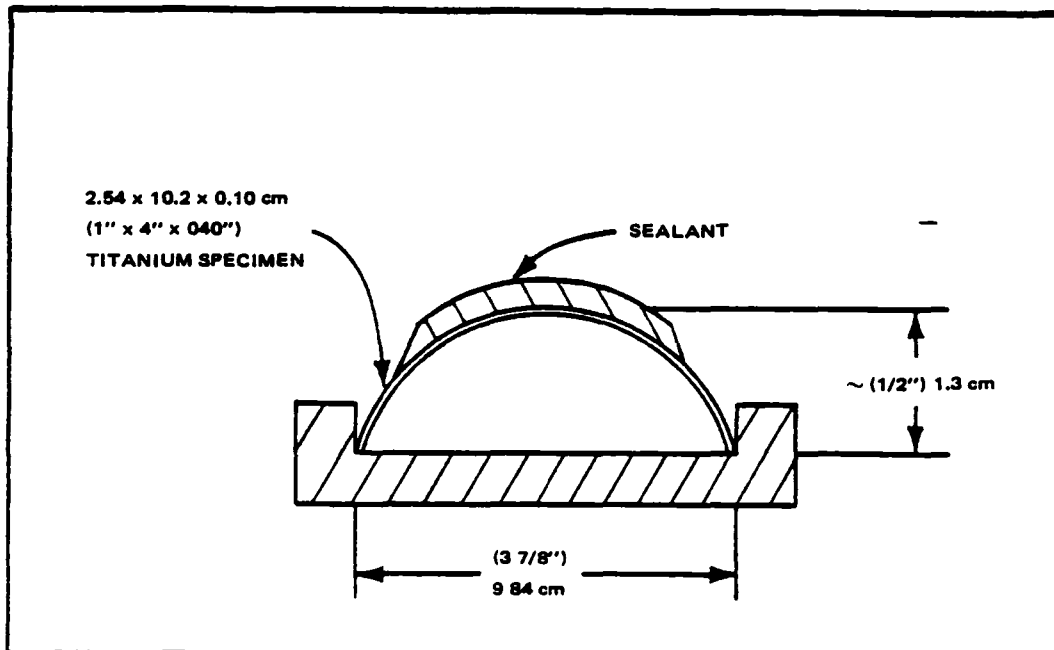
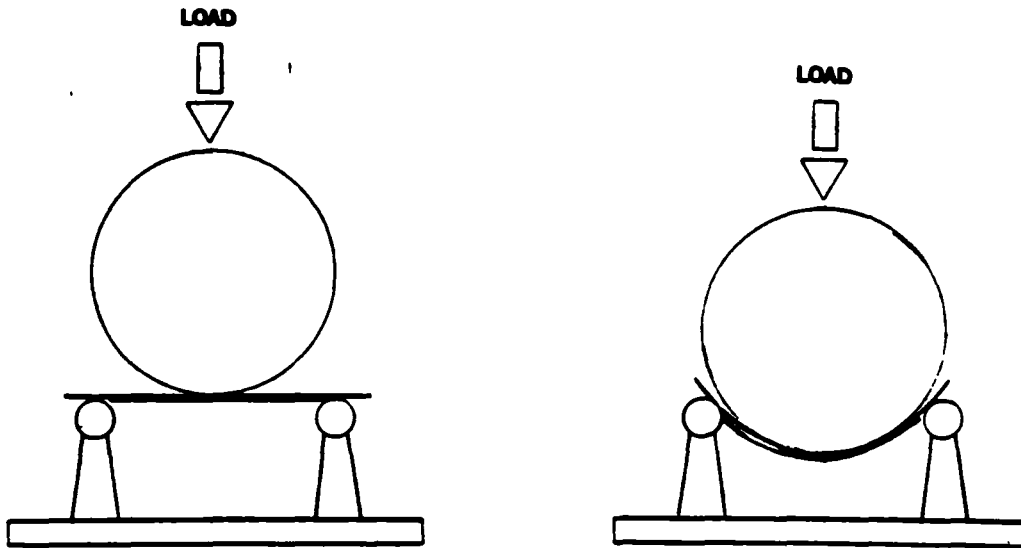

Figure 1. Stress corrosion test.

4.6.7 Low temperature flexibility. The sealing compound shall be applied in a 10.2 x 5.1 x 0.15 cm (4 x 2 x 0.060 inch) strip to one 15.2 x 2.5 x 0.16 cm (6 x 1 x 0.062 inch) aluminum coupon by pressing down with teflon plates and post-curing at 154°C (310°F) for one hour. The test fixture shall consist of a support fixture with a 10.2 cm (4 inch) span and a circular mandrel 10.2 cm (4 inch) in diameter as shown below.



The sample and test fixture shall then be placed into an environmental chamber mounted on an Instron Mechanical Testing machine. The environmental chamber shall then be cooled to and maintained at -54°C (-65°F). After thermal equilibration, the mandrel shall be driven down 3.9 cm (1.55 inch) at a rate of 50.8 cm (20 inches/min), bending the sample around the mandrel. Panel shall be removed and evaluated per Paragraph 3.3.8.

4.6.8 Peel strength. The panels listed in Table III shall be used for evaluation of peel strength. At least 12.7 cm of the panels shall be coated on one side with a 0.32 ±0.04 cm thickness of sealing compound. A 7.0 by 30.5 cm strip of wire screen (20- to 40-mesh aluminum or monel wire fabric) or wire screen conforming to Type III of CCC-C-419 shall be impregnated with sealant, so that approximately 12.7 cm at one end is completely covered on both sides. The sealant must be worked well into the fabric. The sealant-impregnated end of the fabric shall be placed on the sealant coated panel,

and smoothed down on the layer of the sealant, taking care not to trap air beneath the fabric. An additional 0.08 cm thick coating of sealing compound shall be applied over the fabric. After post-cure at 154°C (310°F) for 1 hour, the panels shall be completely immersed in covered glass vessels in the fluids and under the conditions listed in Table III. (Immersion in wide-mouth quart jars with 2 panels in each jar is suitable.) After specified exposure at 60 ±1°C (140 ±2°F), the panels shall be cooled in the fluid for 24 hours at standard conditions. The peel strength shall be measured within 10 minutes after removal from the test fluid. A 2.5 cm wide section shall be cut through the fabric and sealing compound on each panel to provide the center inch for the peel test. The specimens shall be stripped back at an angle of 180 degrees to the metal panel in a suitable tensile testing machine having a jaw separation rate of 5 cm per minute. During the peel strength testing, three cuts shall be made through the sealing compound to the panel in an attempt to promote adhesive failure. The cut shall be at approximately 2.5 cm intervals. The results shall be the numerical average of the peak loads. Failures of the sealing compound to the fabric shall not be included in the peel strength values.

TABLE III.

Quantity	Panel	Immersion Medium at 60 ±1°C (140 ±2°F)
3	0.10 by 7.0 by 15.2 cm (0.040 by 2-3/4 by 6 inches) aluminum alloy, QQ-A-250/13, T6	JRF 7 days
3	"	JP-4 7 days
3	0.06 to 0.05 by 7.0 by 15.2 cm (0.025 to 0.020 by 2-3/4 by 6 inches), titanium, Type I, Composition B, MIL-T-9046	JRF 7 days
3	"	JP-4 7 days

4.6.9 Tensile strength and elongation. Mixed sealing compound 0.32 ± 0.04 cm thick shall be prepared by pressing between 2 PTFE sheets, removing the top sheet at the end of the rated tack-free time (see Paragraph 3.3.7) and allowing the sealing compound to cure at standard conditions. Fifteen tensile test specimens shall be cut from the sheet using die C as specified in ASTM D412. Three specimens shall be exposed to each of the environmental conditions specified in Paragraph 3.3.15.2 and Table III. Where fluid immersion is specified, the 3 specimens shall be immersed in 400 cc of the fluid. Specimens that are tested immediately after the fluid immersion shall be cooled for 24 hours at standard conditions and tested within 5 minutes after removal from the fluid. Specimens that are tested immediately after oven aging shall be allowed to cool for 16 to 48 hours at standard conditions.

4.6.9.1 Test procedure. The tensile and elongation tests shall be conducted at standard conditions in accordance with ASTM D412 at a jaw separation rate of 50.8 ± 1 cm per minute.

4.6.10 Thermal stability. The weight loss of an approximately 25 mg sample of sealing compound shall be determined through an isothermal thermogravimetric analysis at 300°C over a period of 16 hours.

CHANNEL SEALANT SPECIFICATION

1. Scope

1.1 Scope. This specification covers the requirements for one type of inert permanently plastic non-curing sealing compound for sealing or resealing integral fuel tanks designed for groove-injection type sealing that may be subjected to a service temperature range of -54° to 177° (-65 to $+350^{\circ}\text{F}$).

2. Applicable Documents

2.1 The following documents form a part of this specification to the extent specified herein. In the event of conflict between the documents referenced herein and the contents of this specification, the contents of this specification shall be considered a superceding requirement.

Specifications

Federal

QQ-A-250/4	Aluminum Alloy
QQ-A-250/13, T ₆	Aluminum Alloy
TT-E-751	Ethyl Acetate, Technical, Organic Coatings, Use
TT-M-261	Methyl-Ethyl-Ketone (for use in Organic Coatings)
TT-N-97	Naptha, Aromatic
TT-S-735	Standard Test Fluids, Hydrocarbon
TT-T-548	Toluene; Technical

Military

MIL-F-5566	Fluid, Anti-Icing (Isopropyl Alcohol)
MIL-T-9046	Titanium Alloy

3. Requirements

3.1 Qualification. The sealing compound furnished under this specification shall be product which has been tested, and passed the qualification tests specified herein, and has been listed on or approved for listing on the applicable qualified products list.

3.2 Material. The sealing compound furnished under this specification shall be a permanently plastic non-curing product of high quality suitable for the purpose intended and so manufactured as to meet all the requirements specified herein. The sealing compound shall not contain solvents or curing agents of any type.

3.2.1 Preparation of Sealant.

3.2.1.1 Polymerization. The channel sealant shall be prepared from 50.0 grams of perfluoroalkyleneetherdiamidoxime (NASA Ames) and 20.0 grams of perfluoroalkyleneetherdinitride (NASA Ames). The two components shall be mixed in a pyrex dish 20.3 x 20.3 x 5.1 cm (8 x 8 x 2 inches) and cured in a convection oven according to the following schedule:

- a. 6 hours at 127°C (260°F) - intermittently
- b. 70 hours at 154°C (310°F)
- c. 24 hours at 177°C (350°F)

The polymer prior to milling shall exhibit by Thermogravimetric analysis (in air at 20°C/minute) an onset of degradation temperature of 300°C or higher and by isothermal gravimetric analysis a weight loss no greater than 5 percent at 300°C in air for 15 hours.

3.2.1.2 Milling. The milling operation shall be performed in a drybox so that asbestos contamination will not occur as per OSHA regulations. Filler level of the sealant is given in by parts by weight

Polymer (3.2.1.1) 100
Lithium aluminum silicate (Lithafrax #2122, Carborundum) 55
Asbestos (RG-244 "Calidria", Union Carbide) 15
Metal deactivator (Irganox MD-1024, Ciba-Geigy) 5

The fillers shall be milled for at least 30 minutes and until the appearance of the material indicates complete and uniform dispersion. The asbestos shall be milled in first, followed by the lithium aluminum silicate and the metal deactivator. After milling cure the material for 1 hour at 154°C (310°F).

3.3 Appearance. The sealing compound shall be free of lumps or agglomerate masses and shall exhibit no separation of components. Occluded gases shall not be permitted.

3.4 Specific Gravity. The sealing compound shall have a maximum specific gravity of 1.90 when tested as specified in Paragraph 4.6.1.

3.5 Nonvolatile Content. The nonvolatile content of the sealing compound shall be not less than 99 percent when tested as specified in Paragraph 4.6.2.

3.6 Fuel Resistance. The percentage change in volume of the sealing compound shall be no greater than ± 10 percent and the weight loss shall be less than 0.30 percent when tested as specified in Paragraph 4.6.3. At no time shall the sealing compound show signs of cracks, powdering, hardening or loss of adhesion. The material subjected for lot acceptance test shall not have swell or weight loss greater than the value obtained on qualification inspection.

3.7 Adhesion. The cohesive failure shall not be less than 95 percent when tested as specified in Paragraph 4.6.4.

3.8 Corrosion. The sealing compound shall cause no corrosion on the metal surfaces when tested as specified in Paragraph 4.6.5.

3.9 Seal Efficiency. When tested as specified in Paragraph 4.6.6, there shall be no leakage along the faying surfaces and the sealing compound shall remain reinjectable.

3.10 Thermal Extrusion. The sealing compound shall not extrude more than 3.18 cm (1.25 inches) from the ends of the tube, and not more than 1.27 cm (0.50 inch) from the drilled holes when tested as specified in Paragraph 4.6.7.

3.11 Low Temperature Flexibility. The sealing compound shall show very little cracking or loss of adhesion when tested as specified in Paragraph 4.6.8.

3.12 Resistance to Pressure Rupture. The sealing compound when tested as specified in Paragraph 4.6.9, shall have a minimum average blowout pressure of 8 pounds per square inch for the control specimen (Paragraph 4.6.9.1), for the specimen exposed to fuel (Paragraph 4.6.9.2), and for the specimen tested at $177 \pm 1^{\circ}\text{C}$ ($350 \pm 2^{\circ}\text{F}$) (Paragraph 4.6.9.3).

3.13 Workmanship. The sealing compound shall be a homogeneous product manufactured by such processes to meet the requirements of this specification.

4. Quality Assurance Provisions

4.1 Responsibility for Inspection. Unless otherwise specified in the contract or purchase order, the supplier is responsible for the performance of all inspection requirements as specified herein. Except as otherwise specified, the supplier may utilize his own facilities or any commercial laboratory acceptable to the Government. The Government reserves the right to perform any of the inspections set forth in the specification where such inspections are deemed necessary to assure supplies and services conform to prescribed requirements.

4.2 Classification of Inspection. The inspection of the sealing compound shall be classified as follows:

- a. Qualification Inspection (Paragraph 4.3)
- b. Quality Conformance Inspection (Paragraph 4.4)

4.3 Qualification Inspection. The qualification inspection performed by the qualification laboratory shall consist of a review for approval of the submitted manufacturer's report, and subjecting the qualification sample (Paragraph 4.3.1) to examination and testing for all the requirements in Section 3 of this specification.

4.3.1 Qualification Sampling Instructions. The qualification test sample shall consist of 200 grams of the compound upon which qualification is desired.

4.4 Quality Conformance Inspection. Quality conformance inspection shall consist of the lot acceptance test specified in Paragraph 4.4.2.

4.4.1 Sampling

4.4.1.1 Lot. A lot shall consist of a batch of all the sealing compound manufactured from the same components processed at the same time.

4.4.2 Lot Acceptance Tests. A sample, sufficient in size for test purposes, shall be selected at random and subjected to the lot acceptance tests of Table 1.

TABLE I - LOT ACCEPTANCE TESTS

Test	Requirement Paragraph	Test Paragraph	Number of Determinations Required
Nonvolatile Content	3.5	4.6.2	2
Fuel Resistance	3.6	4.6.3	3
Adhesion	3.7	4.6.4	3
Pressure Rupture	3.12	4.6.9	1

4.5 Test Conditions. Unless otherwise specified, tests shall be conducted at a temperature of $25 \pm 1^{\circ}\text{C}$ ($77 \pm 2^{\circ}\text{F}$) and a relative humidity of 50 ± 5 percent.

4.5.1 Tolerances on Environmental Conditions. Unless otherwise specified, tolerances on environmental conditions shall be as follows:

- a. Days ± 4 hours
- b. Hours ± 1 hour
- c. Minutes ± 5 minutes

4.5.2 Preparation of Test Panels and Fixtures

4.5.2.1 Preliminary Cleaning. Gross soil, marking ink, or grease pencil, if present, shall be removed by scrubbing with a cheesecloth wet with methyl-ethylketone conforming to TT-M-261.

4.5.2.2 Cleaning. All surfaces to which the sealing compound will be applied shall be cleaned by scrubbing and rinsing in solvent formulated in accordance with Table II.

After rinsing and while still wet, the test surface shall be wiped dry with clean cheesecloth. (The cheesecloth shall be free of lint and starch and shall contain no dye, rust, oil, or other foreign material.)

TABLE II - FORMULATION OF CLEANER

Ingredient	Specification	Percent by Volume
Aromatic petroleum naphta	TT-N-97, Type I, Grade B	50
Ethyl acetate	TT-E7-751	20
Methylethylketone	TT-M-261	20
Isopropyl alcohol	MIL-F-5566	10

4.5.3 Primer. When specified, a primer shall be applied after the surfaces have been prepared in accordance with Paragraph 4.5.2. The primer shall be applied in accordance with manufacturer's instructions.

4.5.4 Recleaning. Recleaning, when required after Paragraph 4.5.2 or 4.5.3, shall be in accordance with Paragraph 4.5.2.2.

4.6 Test Methods

4.6.1 Specific Gravity. The specific gravity shall be determined on the test panels prepared for the fuel resistance test (Paragraph 4.6.3.2). The panels before and after the application of the sealing compound shall be weighed accurately ± 0.001 grams, in air and distilled water at $25 \pm 1^\circ$ ($77 \pm 2^\circ\text{F}$). The specific gravity shall be determined in triplicate and determined by the following calculations:

$$\text{Specific Gravity} = \frac{W_1 - W_3}{(W_1 + W_4) - (W_2 + W_3)}$$

W_1 = weight of panel in air

W_2 = weight of panel in water

W_3 = weight of panel and sealing compound in air

W_4 = weight of panel and sealing compound in water

4.6.2 Nonvolatile Content. Five to ten grams of sealing compound shall be transferred to a tared covered cup approximately three inches in diameter and 3/4 inch in depth. The specimen shall be weighed to the nearest milligram

and the weight of the sealing compound calculated. The cover shall then be removed and the sealing compound heated for 7 days at $70 \pm 1^\circ\text{C}$ ($158 \pm 2^\circ\text{F}$). It shall then be cooled in a dessicator at standard conditions, the cover replaced, and the specimen reweighed. The test shall be run in duplicate and the average of the results reported. The percentage of the total nonvolatile content shall be calculated as follows:

$$\text{Percent nonvolatile content} = \frac{\text{final weight}}{\text{initial weight}} \times 100$$

4.6.3 Fuel Resistance

4.6.3.1 Formulation of Jet Reference Fluid. The jet reference fluid required for conducting the fuel resistance test and fluid immersion tests of this specification shall be formulated as follows:

Toluene (TT-T-548)	30 volumes
Cyclohexane (technical grade)	60 volumes
Iso-octane (TT-S-735, Type 1)	10 volumes
Tertiary butyl disulfide (doctor sweet)	1 volume
Tertiary butyl mercaptan	0.015 ± 0.0015 weight percent of other four components

4.6.3.1.1 Jet Reference Fluid Tests. The mercaptan sulfur content when tested in accordance with Method 5206 of FED-STD-791 shall be 0.0050 ± 0.0005 weight percent of the jet fluid. The total sulfur content when tested in accordance with Method 5201 of FED-STD-791 shall be 0.400 ± 0.005 weight percent of the jet fluid.

4.6.3.1.2 The fluid should be stored out of contact with light in containers which are inert to the fluid ingredients. (Welded aluminum, nongalvanized welded steel or glass containers are suitable). Fluid older than 90 days shall be retested for mercaptan and total sulfur content.

4.6.3.2 Test Procedure. Three panels, 0.081 by 5.1 by 5.7 cm (0.032 by 2 by 2.25 inches) of aluminum conforming to QQ-A-250/4 shall be tared accurately (± 0.001 gram) in air (W_1) and in water (W_2). A pad of sealing compound 0.15 x 5.1 by 5.1 cm (0.06 by 2 by 2 inches) shall be applied to each of the

panels. One-quarter inch along one edge shall not be coated for handling purposes. The volume of the specimens shall be determined by weighing in air (W_3) and in water (W_4). The specimens shall be immersed in jet reference fluid for 25 days at $49 \pm 1^\circ\text{C}$ ($120 \pm 2^\circ\text{F}$), plus 60 hours at $71 \pm 1^\circ$ ($160 \pm 2^\circ\text{F}$), plus 6 hours at $82 \pm 1^\circ\text{C}$ ($180 \pm 2^\circ\text{F}$). The volume of the specimens shall be determined immediately upon removal from the fuel by weighing in air (W_5) and in water (W_6). The percent change in volume shall be determined by the following formula and the average of the three specimens reported to the nearest percent.

$$\frac{(W_3 + W_6) - (W_4 + W_5)}{(W_1 + W_4) - (W_2 + W_3)} \times 100 = \text{percent change in volume}$$

Each specimen shall then be placed in a $93 \pm 1^\circ\text{C}$ ($200 \pm 2^\circ\text{F}$) oven for 24 hours, cooled to room temperature, and then weighed again (W_7). The percent weight change shall be determined by the following formula and the average of the three specimens reported to the nearest 0.1 percent.

$$\frac{W_3 - W_7}{W_3 - W_1} \times 100 = \text{percent weight change}$$

The specimens shall be inspected for evidence of hardening, cracking, powdering, or loss of adhesion.

4.6.4 Peel Strength. The panels listed in Table III shall be used for evaluation of peel strength. The panels shall be cleaned and prepared as specified in Paragraph 4.5.2. The panels shall then be scrubbed with Ajax and a 1 percent solution of A-187 silane in methanol shall be applied and dried at room temperature for one hour. At least 12.7 cm of the panels shall be coated on one side with a 0.32 ± 0.04 centimeters of sealing compound. A 7.0 by 30.5 cm strip of wire screen (20- to 40-mesh aluminum or monel wire fabric) or wire screen conforming to Type III of CCC-C-419 shall be impregnated with sealant, so that approximately 12.7 cm at one end is completely covered on both sides. The sealant must be worked well into the fabric. The sealant-impregnated end of the fabric shall be placed on the sealant coated panel, and smoothed down on the layer of the sealant, taking

care not to trap air beneath the fabric. An additional 0.08 cm thick coating of sealing compound shall be applied over the fabric. After a post-cure at 154°C (310°F) for one hour, the panels shall be completely immersed in covered glass vessels in the fluids and under the conditions listed in Table III. (Immersion in wide-mouth quart jars with 2 panels in each jar is suitable.) After specified exposure at 60 ±1°C (140 ±2°F), the panels shall be cooled in the fluid for 24 hours at standard conditions. The peel strength shall be measured within 10 minutes after removal from the test fluid. A 2.5 cm wide section shall be cut through the fabric and sealing compound on each panel to provide the center inch for the peel test. The specimens shall be stripped back at an angle of 180 degrees to the metal panel in a suitable tensile testing machine having a jaw separation rate of 5 cm per minute. During the peel strength testing, three cuts shall be made through the sealing compound to the panel in an attempt to promote adhesive failure. The cuts shall be at approximately 2.5 cm intervals. The results shall be the numerical average of the peak loads. Failures of the sealing compound to the fabric shall not be included in the peel strength values.

TABLE III.

Quantity	Days in Test	Panel	Immersion Conditions at 60 ±1°C (140 ±2°F)
3	7	0.10 by 7.0 by 15.2 cm (0.040 by 2-3/4 by 6 inches) aluminum alloy, QQ-A-250/13, T ₆	JRF
3	70	"	JRF with change of fluid every 14 days
3	7	"	3% aq. NaCl/JRF
3	14	"	3% aq. NaCl/JRF
3	7	0.06 to 0.05 by 7.0 by 15.2 cm (0.025 to 0.020 by 2-3/4 by 6 inches), titanium, Type I, Composition B, MIL-T-9046	JRF
3	7	"	3% aq. NaCl/JRF

4.6.5 Corrosion resistance. Three panels, 0.10 by 7.0 by 15.2 cm (0.040 by 2-3/4 by 6 inches) of aluminum alloy conforming to QQ-A-250/13, T₆, and three panels of 0.06 to 0.05 by 7.0 by 15.2 cm (0.025 to 0.020 by 2-3/4 by 6 inches), titanium, Type I, composition B, MIL-T-9046, shall be cleaned and prepared as specified in Paragraph 4.5.3. The aluminum panels shall be Ajax scrubbed and primed with a 1 percent solution of A-187 silane in methanol and dried at room temperature for 1 hour. The titanium panels shall be treated for 2 hours with Pasa Gel and primed with a 1 percent solution of A-187 silane in methanol, then dried for one hour at room temperature. The sealant compound shall be applied to the test panels in 1/2 inch diameter globs at three positions; 2.5 cm from the bottom of each panel, 7.6 centimeters from the bottom and 12.7 centimeters from the bottom. The panels shall be immersed vertically in a covered glass vessel with a layer of a 3 percent aqueous sodium chloride solution to a 5 centimeter depth topped with a 5 centimeter depth layer of JRF. The fillets of sealant shall be exposed in the container to salt solution, JRF liquid, and vapor phases. The sealed container shall be heated in a water bath for 25 days at 49 ±1°C (120 ±2°F), then 60 hours at 71 ±1°C (160 ±2°F) and 6 hours at 82 ±1°C (180 ±2°F). After completion of test cycle, the test panels shall be removed from the immersion medium and the sealant examined for evidence of deterioration. The sealant shall be removed from the test panel and the surface of the metal shall be examined for evidence of corrosion.

4.6.6 Seal efficiency. Two groove injection pressure test jigs conforming to Figure 1 shall be packed with about 20 grams of sealant in the grooves. The two jigs shall be assembled with 1/4 inch bolts. Install 5 mil washers (0.26 ID, 0.50 OD) on each bolt between the plates on assembly. Observe the extrusion of sealant through the three injection holes positioned around the jig at 120° intervals. Injection holes shall be blocked with plug screws during all of the following environmental exposures. Air test for leakage at 10 psi.

4.6.6.1 Fill one jig with 3 percent aqueous sodium chloride and expose at 49 ±1°C (120 ±2°F) for 25 days followed by 60 hours at 71 ±1°C (160 ±2°F)

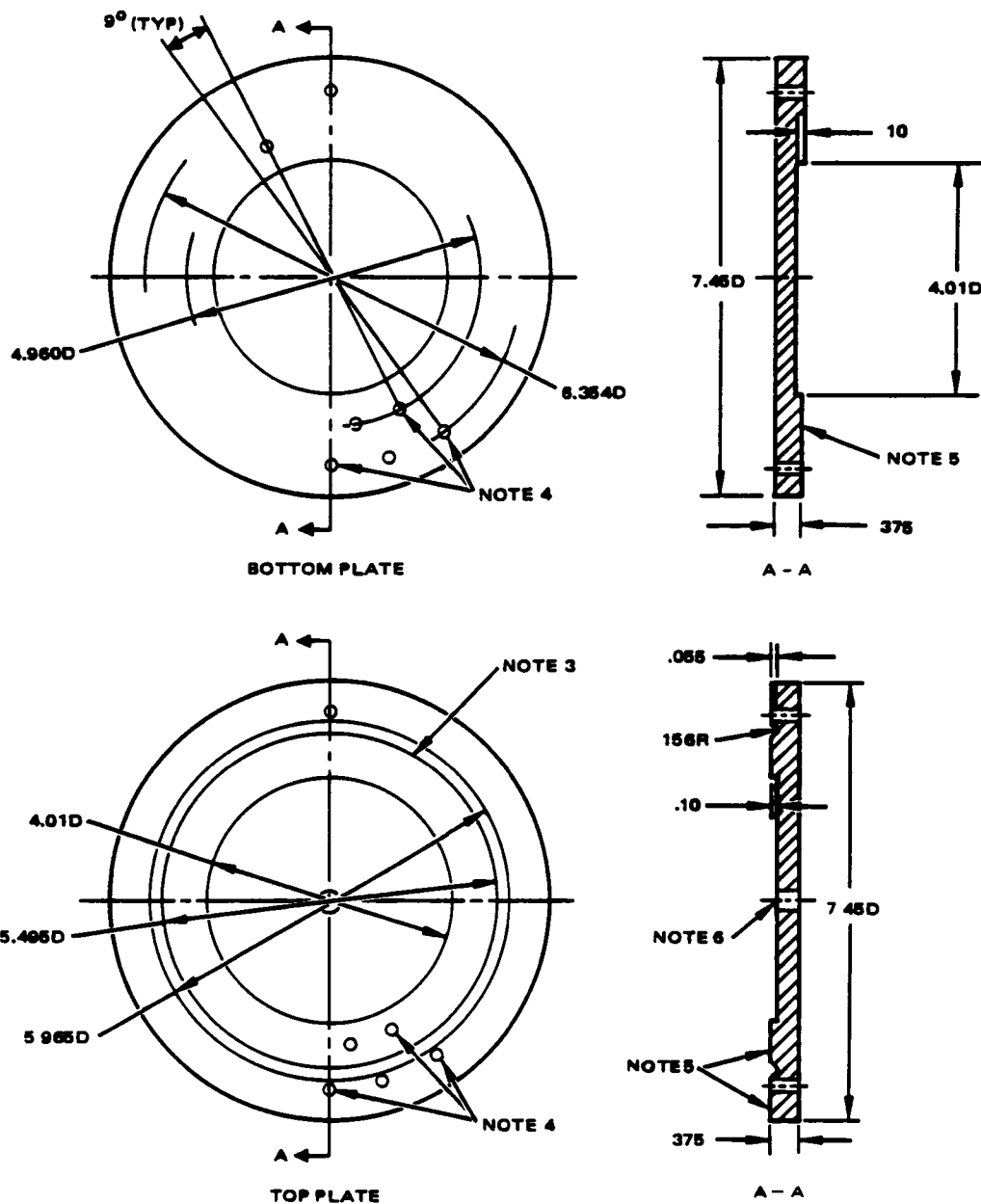

NOTES

- 1 MATERIAL - 375 ALUMINUM PLATE, 2024-T851 PER QQ-A-250/A.
- 2 TOLERANCES XX ± 010, .XXX ± 005, HOLE DIAM. ± .002, ANGLES ± 0° 15'
3. HOLE CENTERED ON GROOVE 3 PLACES THRU TOP PLATE AT 120° INTERVALS (CSINK 100° X .164 DIAM. ON SIDE OPPOSITE GROOVE. TAP 8-32 UNC-3B THRU PER MIL-S-7742. INSTALL MAS 1081-08A2N SCREW.)
4. 25 DIAM. HOLE (40 PLACES THRU EACH PLATE TO MATCH)
- 5 SURFACE INDICATED SHALL BE FLAT WITHIN .001 MAX
6. DRILL AND TAP FOR 1/4 NPT
- 7 DIMENSIONS ARE IN INCHES.

Figure 1. Groove injection pressure test jig.

and 6 hours at $82 \pm 1^\circ\text{C}$ ($180 \pm 2^\circ\text{F}$). Drain the μg and place in an oven at $177 \pm 2^\circ\text{C}$ ($350 \pm 5^\circ\text{F}$). When the temperature has stabilized, apply pressure to the μg to 5 psi and check for leakage as follows:

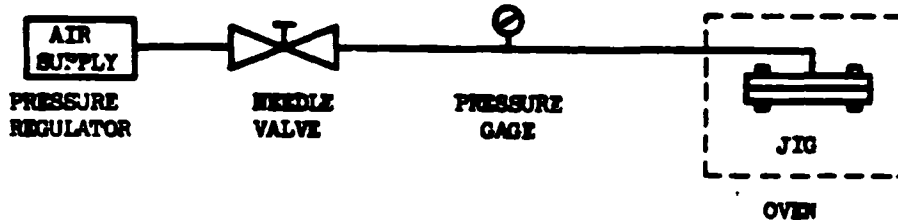

1. Pressurize jig.
2. Close needle valve.
3. Watch for pressure drop. (Pressurized system must be leak free from needle valve to test jig prior to start of test.)

Maintain the 5 psi pressure for 2 hours. At the end of two hours, increase the pressure to 10 psi for one minute and again check for leakage.

4.6.6.2 The second jig shall be filled with jet reference fluid, and pressurized to 5 psi. The μg shall then be subjected to $49 \pm 1^\circ\text{C}$ ($120 \pm 2^\circ\text{F}$) for 100 hours followed by 10 hours at $71 \pm 1^\circ\text{C}$ ($160 \pm 2^\circ\text{F}$) and one hour at $82 \pm 1^\circ\text{C}$ ($180 \pm 2^\circ\text{F}$). The μg shall then be drained and exposed in a dry oven for 20 hours at $107 \pm 1^\circ\text{C}$ ($225 \pm 2^\circ\text{F}$) followed by 10 hours at $154 \pm 2^\circ\text{C}$ ($310 \pm 5^\circ\text{F}$) and one hour at $177 \pm 2^\circ\text{C}$ ($350 \pm 5^\circ\text{F}$) with 5 psi pressure applied continuously. At the end of the $177 \pm 2^\circ\text{C}$ ($350 \pm 5^\circ\text{F}$) exposure, increase the pressure to 10 psi for one minute. Test the jig for leakage as specified in 4.6.6.1 immediately after the fuel exposure and at the end of the one hour exposure at $177 \pm 2^\circ\text{C}$ ($350 \pm 5^\circ\text{F}$) while the pressure is at 10 psi. The above aging shall constitute one cycle.

4.6.7 Thermal extrusion. Two holes 0.16 cm in diameter shall be drilled (5 centimeters apart and 5 centimeters from each end) through one wall of an aluminum tube (0.32 cm ID by 0.48 cm OD by 15.2 cm long). The tube after being cleaned and dried shall be injected with sealing compound until full. Excess sealing compound shall be removed flush with the holes and ends of the tubes. The tube shall be placed in a $177 \pm 2^\circ\text{C}$ ($350 \pm 5^\circ\text{F}$) oven for 30 minutes, cooled to room temperature, and the length of extrusions measured.

4.6.8 Low temperature flexibility. The sealing compound shall be applied in a $10.2 \times 0.64 \times 0.15$ cm (4 by 0.25 by 0.060 inch) strip to one $15.2 \times 2.5 \times$

0.16 cm (6 by 1 by 0.062 inch) aluminum coupon by pressing down with teflon spacers and post-curing at 154°C (310°F) for one hour. The test fixture shall consist of a support fixture with 10.2 cm span and a circular mandrel 10.2 cm in diameter as shown in Figure 2. The sample and test fixture shall be placed into an environmental chamber mounted on an Instron Mechanical Testing machine. The environmental chamber shall then be cooled to and maintained at -54°C (-65°F). After thermal equilibration, the mandrel shall be driven down 3.94 cm (1.55 inches) at a rate of 50.8 cm (20 inches) per minute bending the sample around the mandrel. Panel shall be removed and evaluated per Paragraph 3.11.

4.6.9 Pressure rupture. Pack the sealing compound into nine blowout specimens (see Figure 3), taking care to eliminate air bubbles, and stabilize the specimens at 25 ±1°C (77 ±2°F) for a minimum period of 24 hours. The specimens shall be cooled to below -29°C (-20 ±2°F) and the excess material trimmed from the surfaces with a razor blade. The specimens shall then be tested as described below.

4.6.9.1 One of the specimens shall be mounted in the pressure rupture jig (Figure 3). One air hose bib of the apparatus shall be connected to a manometer, the other to a variable pressure source. The assembly shall be immersed in a water bath at 25 ±1°C (77 ±2°F) and stabilized for five minutes.

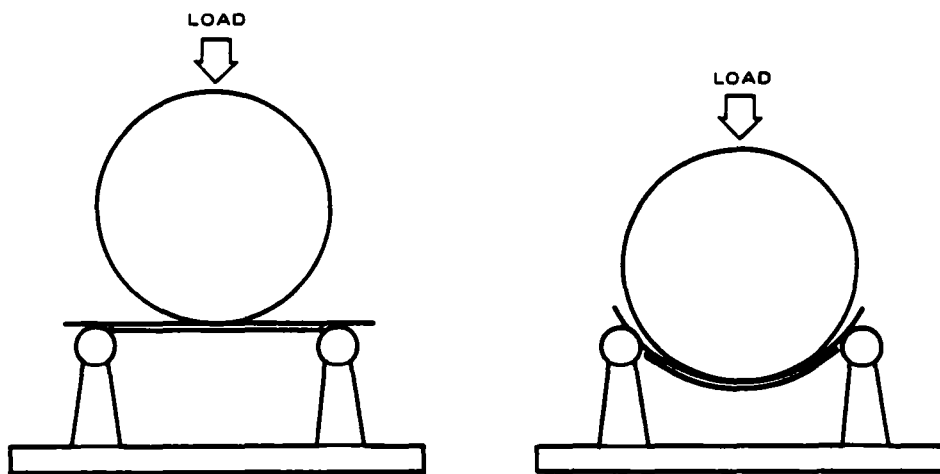
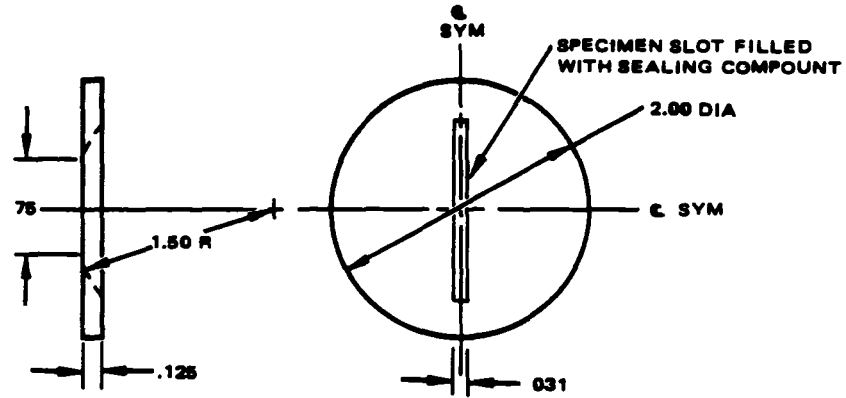
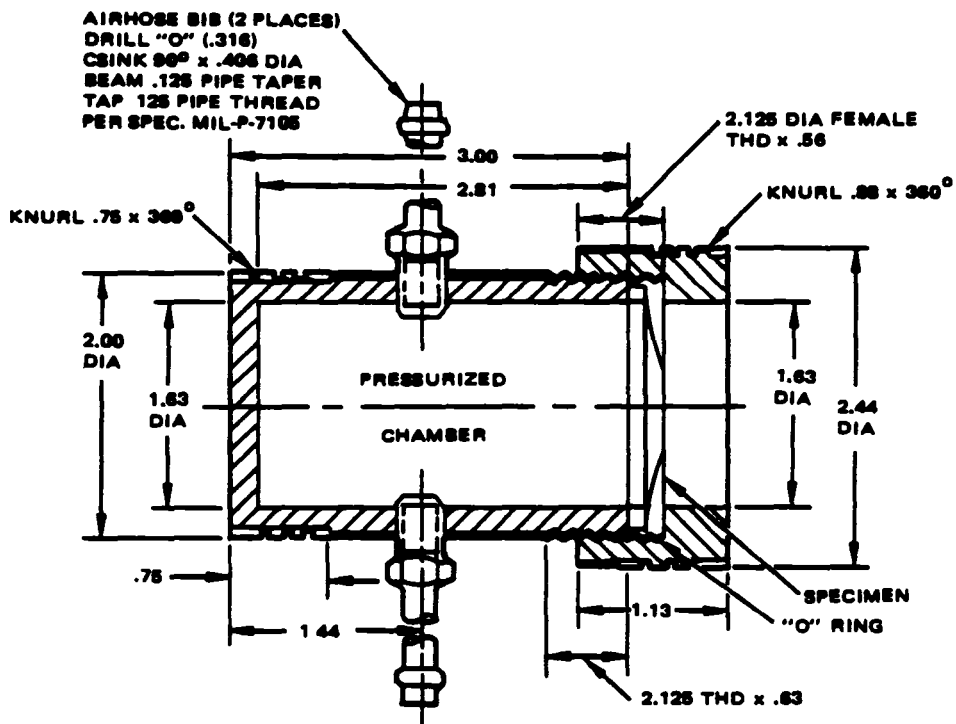

Figure 2. Low temperature flexibility test fixture.



SPECIMEN



1. DIMENSIONS ARE IN INCHES.

Figure 3. Pressure rupture jig.

Starting at atmospheric pressure, the pressure on the apparatus shall be uniformly increased at the rate of one inch of mercury per 15 seconds until failure occurs. A continuous stream of air bubbles observed to come from the specimen shall constitute a failure. The pressure applied at the time of failure shall be recorded. Test two additional specimens in the same manner. The average failure pressure of the three specimens shall be reported to the nearest 0.5 inch of mercury.

4.6.9.2 Three of the blowout specimens shall be immersed in jet reference fluid for 120 hours at $49 \pm 1^{\circ}\text{C}$ ($120 \pm 2^{\circ}\text{F}$) plus 60 hours at $71 \pm 1^{\circ}\text{C}$ ($160 \pm 2^{\circ}\text{F}$) and 6 hours at $82 \pm 1^{\circ}\text{C}$ ($180 \pm 2^{\circ}\text{F}$). The specimens shall then be removed from the test fuel one at a time and tested as described in Paragraph 4.6.9.1.

4.6.9.3 The remaining three blowout specimens shall be tested as described in Paragraph 4.6.9.1 with the following exception: the pressure rupture jig assembly shall be placed in an oven at $177 \pm 2^{\circ}\text{C}$ ($350 \pm 5^{\circ}\text{F}$) and allowed to stabilize for 15 minutes after the specimen reaches temperature. Failure shall be indicated by a rapid drop in pressure.

1 Report No NASA CR-166377		2 Government Accession No		3 Recipient's Catalog No	
4 Title and Subtitle Studies of New Perfluoroether Elastomeric Sealants				5 Report Date September 1981	
				6 Performing Organization Code	
7 Author(s) D. I. Basiulis and D. P. Salisbury				8 Performing Organization Report No FR-81 76-966	
9 Performing Organization Name and Address Hughes Aircraft Co. Culver City, CA				10 Work Unit No T5454	
				11 Contract or Grant No NAS2-10334	
				13 Type of Report and Period Covered Final Contractor Report	
12 Sponsoring Agency Name and Address National Aeronautics and Space Administration Washington, DC 20546				14 Sponsoring Agency Code 533-01-11	
15 Supplementary Notes Technical Monitor: Dr. Robert W. Rosser, M/S 233-6, NASA Ames Research Center, Moffett Field, CA 94035 (415) 965-5244, FTS 448-5244					
16 Abstract Channel and filleting sealants were developed successfully from cyano- and diamidoxime-terminated perfluoroalkyleneether prepolymers that were made by NASA. The prepolymers were polymerized, formulated and tested. The polymers and/or formulations therefrom were evaluated as to their physical, mechanical and chemical properties (i.e., specific gravity, hardness, nonvolatile content, corrosion resistance, stress corrosion, pressure rupture resistance, low temperature flexibility, gap sealing efficiency, tensile strength and elongation, dynamic mechanical behavior, compression set, fuel resistance, thermal properties and processability). The channel sealant in its present formulation has excellent pressure rupture resistance and surpasses present MIL specifications before and after fuel and heat aging. The sealant remains soft and pliable. No hardening was evident even after long term exposure to fuel. The fuel resistance of this polymer is excellent with very little volume change and no weight change, even after exposure beyond MIL specifications requirements at elevated temperatures. Gap sealing efficiency at the 5 mil requirement was very good. The channel sealant is easily processable even at very low shear rates and, therefore, application should present no problems. The filleting sealant shows excellent resistance to fuel and other solvents and is much more resistant than Viton. The present formulation shows no corrosive effect on the surface of titanium in long term testing at 288°C (550°F). The sealant has good adhesion to aluminum and titanium.					
17 Key Words (Suggested by Author(s)) Sealants, Fluoroelastomer			18 Distribution Statement Unclassified - Unlimited STAR Category - 45		
19 Security Classif (of this report) Unclassified		20 Security Classif (of this page) Unclassified		21 No of Pages 95	22 Price*

End of Document