

FLOW VISUALIZATION OF SHOCK-  
BOUNDARY LAYER INTERACTION

Warren R. Hingst and Mark Jurkovich  
NASA Lewis Research Center  
Cleveland, Ohio

## Figure 1. Experimental Program

An experimental program is underway in the Lewis 1 X 1 foot supersonic wind tunnel to obtain two and three-dimensional shock-boundary layer interaction data. These interactions are studied both with and without boundary layer bleed. The data are to be of sufficient detail for verification of computational fluid dynamic codes. In addition to the quantitative measurements such as surface static pressure, pitot pressure, flow angularity, and bleed rates, qualitative studies of the flow are made using flow visualization techniques. Surface oil flow using fluorescent dye and laser sheet using water droplets as the scattering material are being used for flow visualization.

### SUPERSONIC FLOW VERIFICATION EXPERIMENTS

GLANCING SIDEWALL SHOCK - B. L.

2-D SHOCK - B. L.

3-D SEPARATED FLOW

EFFECTS OF B. L. BLEED

### QUANTITATIVE MEASUREMENTS

PRESSURES

FLOW ANGULARITY

BLEED RATES

### FLOW VISUALIZATION

SURFACE OIL FLOW

LASER SHEET

Figure 2. Schematic of Experimental Configuration

The experimental configuration consists of a shock generator that spans the tunnel. The shock generated produces a sidewall glancing interaction on the tunnel wall and a ramp interaction on the tunnel floor. The boundary layers in the interactions are those naturally occurring on the tunnel surfaces.

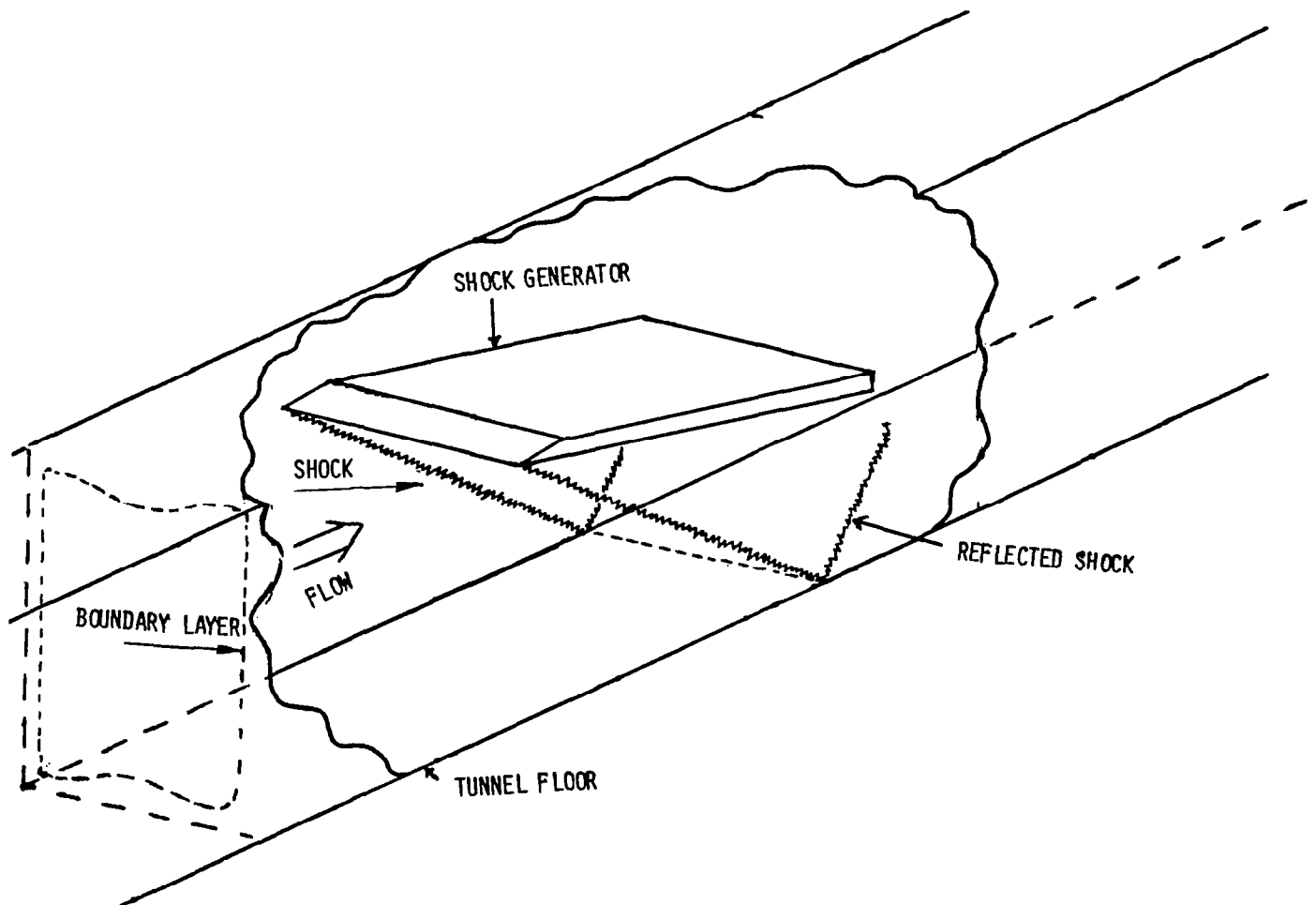

Figure 3. Surface Oil Flow Visualization of Glancing Sidewall Shock-Boundary Layer Interaction

This photograph shows the results of surface oil flow visualization using a fluorescent dye to suppress background reflections. The view is from upstream and across the tunnel. The shock generator can be seen on the upper part of the photograph. The turning of the oil flow shows the upstream influence of the shock propagating through the boundary layer. The results are for a Mach number of 2.5 and a shock generator angle of  $8^{\circ}$ .

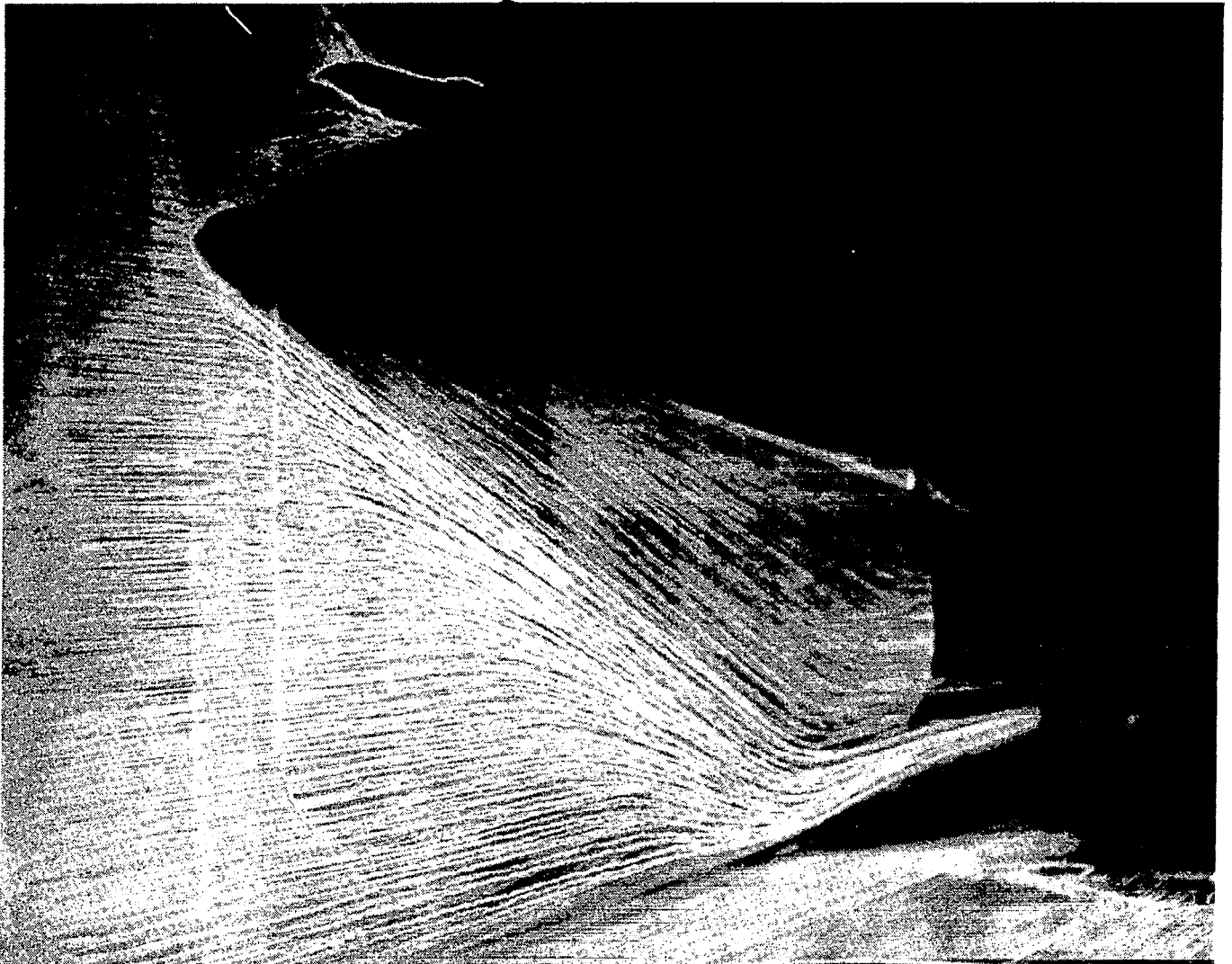

Figure 4. Surface Oil Flow of 3-D Separation on Tunnel Floor

This view of the surface oil flow visualization shows the shock-boundary layer interaction on the tunnel floor. The view is directly from the side. A large three-dimensional flow separation is shown. The flow conditions are the same as described for figure 3.



Figure 5. Schematic of Laser Sheet Configuration

This schematic shows the optical configuration used for the laser sheet flow visualization. The experimental configuration is that shown in figure 2. The laser beam enters the tunnel downstream of the test section. The beam enters an optics package that spreads the beam in one direction with a cylindrical lens and projects it upstream. This optics package is actuated to move the resulting laser sheet up and down or across the tunnel depending on the orientation of the sheet. The scattered light is recorded with a still or T.V. camera located to the side of the shock generator.

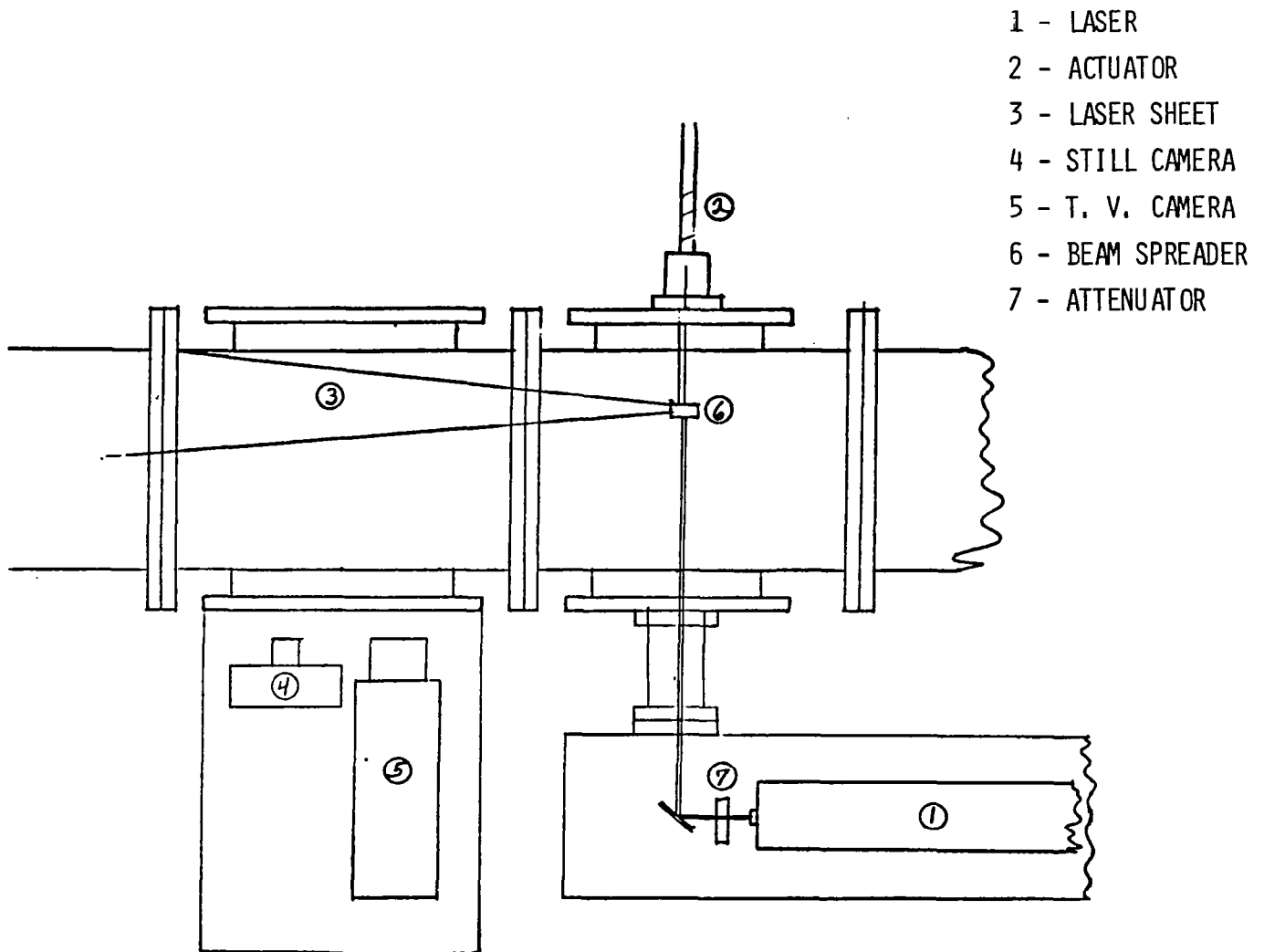

Figure 6. Laser Sheet Flow Visualization on Tunnel Centerline

This photograph shows the laser sheet along the tunnel centerline perpendicular to the tunnel floor. This would correspond to a plane through the center of the separated region on the floor shown in figure 4. The incident shock from the shock generator along with a shock induced by the separation are visible. The separated region is seen as the dark region near the floor. The flow conditions are the same as described for figure 3.

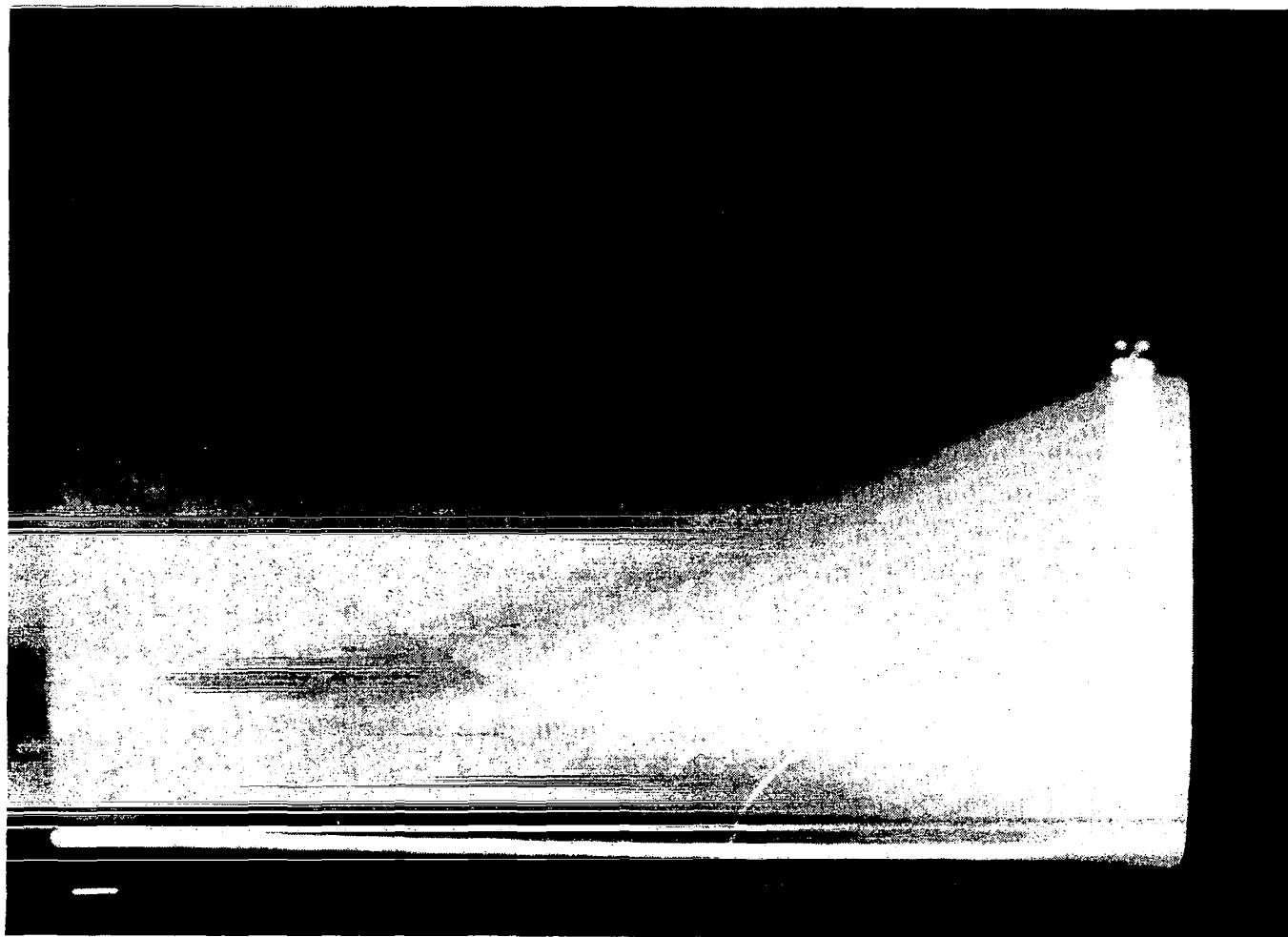
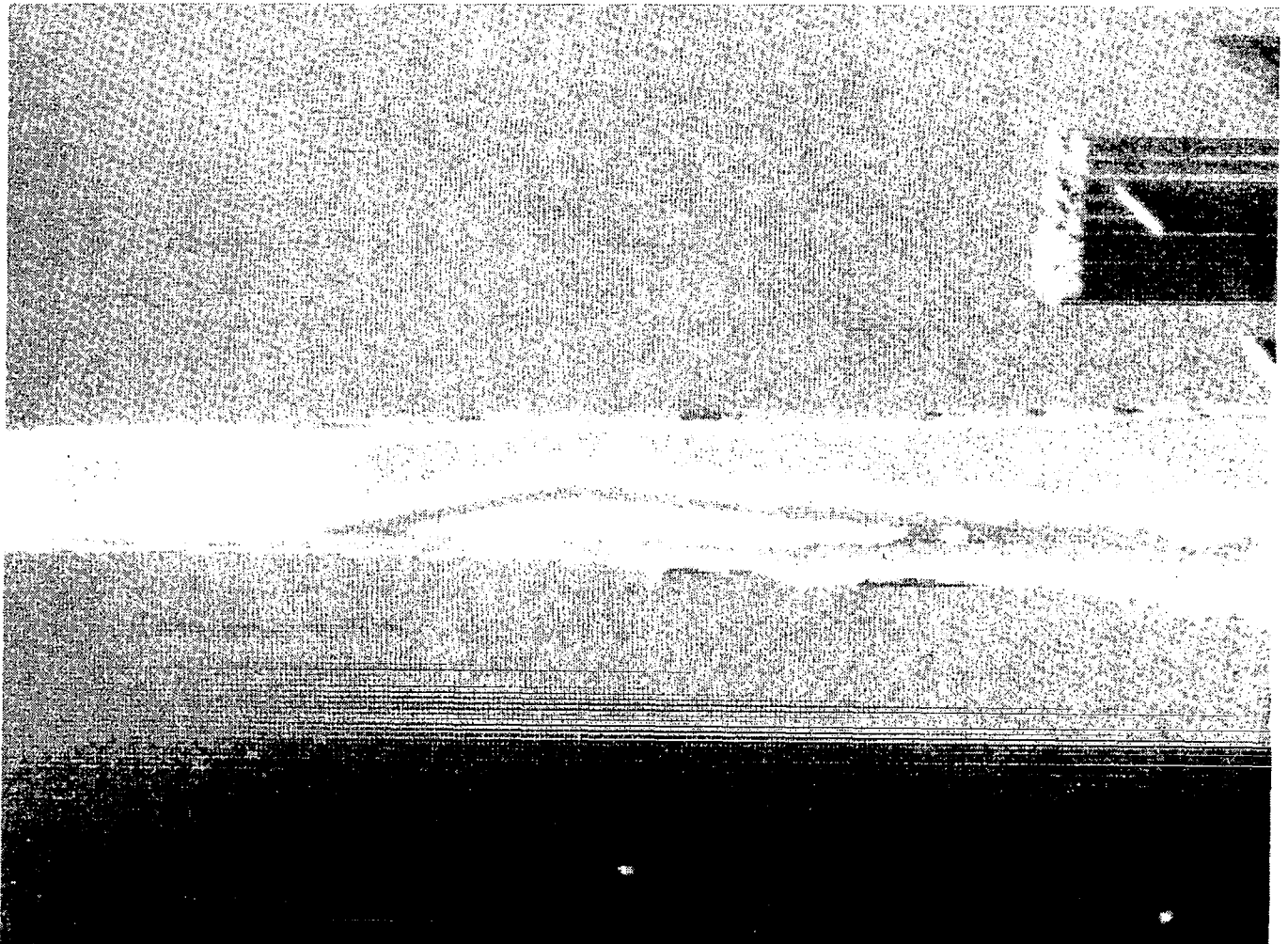

Figure 7. Laser Sheet Flow Visualization of Three-Dimensional Separation

This figure shows the laser sheet localized through the centerline of the three-dimensional flow separation shown by the surface oil flow in figure 4. Here the original laser sheet photograph has been enhanced by an image processor to bring out the density gradients in the scattered light. The various density gradients are represented by a false color image. By taking a series of these cuts through the separated region a three-dimensional representation of the separated flow can be obtained. The tunnel conditions are the same as described for figure 3.



L-82-5678