

MEASUREMENT POTENTIAL
OF
LASER SPECKLE VELOCIMETRY

Ronald J. Adrian
University of Illinois at Urbana-Champaign
Department of Theoretical and Applied Mechanics

Laser speckle velocimetry, hereafter called "LSV", refers to the measurement of fluid velocity by measuring the translation of speckle patterns, or in the simplest case, individual particles that are moving with the fluid. The measurement is accomplished by illuminating the fluid with consecutive pulses of laser light and recording the images of the particles or the speckles on a double exposed photographic plate, Figs. 1 and 2. The plate contains flow information throughout the image plane so that a single double exposure may provide data at hundreds or thousands of points in the illuminated region of the fluid, as illustrated in Fig. 3 (P.G. Simpkins and T.D. Dudderar, 1978, J. Fluid Mech., 89, 665-71). Conventional interrogation of the specklegram involves illuminating the plate to form Young's fringes, whose spacing is inversely proportional to the speckle separation. Subsequently the fringes are digitized and analyzed in a computer, possibly by 2-D FFT, to determine their frequency and orientation, yielding the velocity magnitude and orientation. The time consumed by this process is one of the major drawbacks of LSV at present. For example, current "fast" processing at the rate of 10 s per point would require more than 3 hours to process 10^3 velocities on a single specklegram.

The Young's fringe technique is equivalent to performing a 2-D spatial correlation of the double exposed specklegram intensity pattern, and this observation suggests that correlation should be considered as an alternative processing method. The principle of the correlation technique is that the correlation of the transmission will have a secondary maximum at separations corresponding to the mean displacement of the fluid within the interrogated spot, Figs. 4 and 5. Two methods have been devised which produce an output proportional to the correlation by superposing the spatially translated image of the interrogated spot back onto the specklegram with unity magnification.

The first one, Fig. 6, uses an oscillating mirror with $1\text{ms}/\text{scan}$, whereas the second uses a dual Bragg cell with about $1\mu\text{s}/\text{scan}$. Figure 7 shows a heterodyne technique employing a 2-D Bragg cell.

Simply scanning and recording the correlogram requires enormous data storage when high velocity resolution is required: 128 K words are needed to store 256 line scans with 512 words each, Fig. 8. Clearly, simplified techniques are essential; one possibility is to scan the entire $s_1 - s_3$ plane but only store the (s_1, s_3) addresses of those points which yield correlation values greater than a threshold value. Those points, presumably fewer than a thousand in number if the threshold is properly set, could then be readdressed to obtain their amplitude values. Other possibilities are to use coarse interval scanning followed by scanning with high resolution the limited region containing the correlation peak, or to scan coarsely until a peak is found, followed immediately by high resolution scanning, Fig.9. The velocity is found by calculating the centroid of the correlator peak, and the width of the peak σ_1 should be of the order of a spot diameter, or a particle image diameter.

Some estimates of the performance parameters of an LSV applied to a high speed wind tunnel measurement are shown in Fig. 10. Spatial resolution is poor because the field of view, $1\text{m} \times 0.75\text{m}$, is large and because a modest $F/10$ lens has been assumed. An $F15$ lens combined with a $200\text{mm} \times 150\text{mm}$ field of view would yield 1mm spatial resolution.

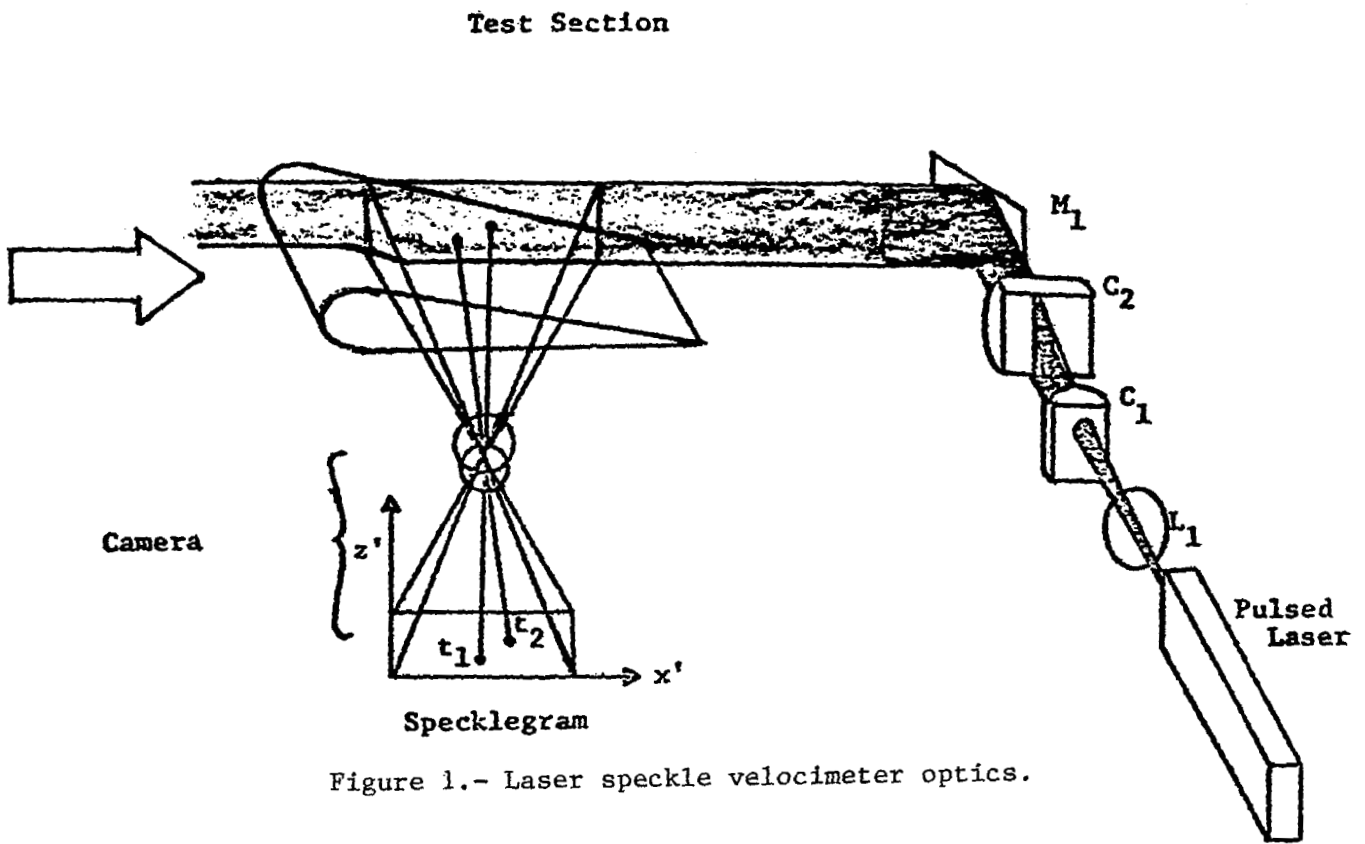

Figure 1.- Laser speckle velocimeter optics.

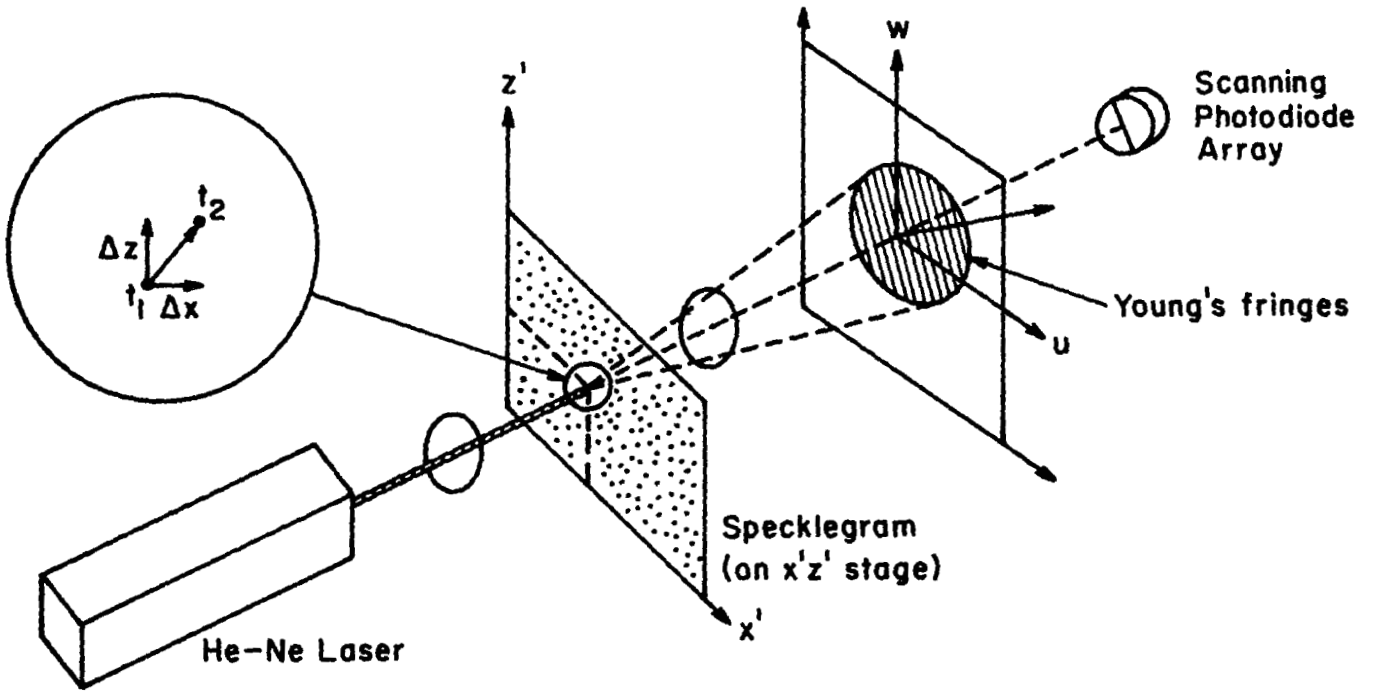

Figure 2.- Specklegram analysis.

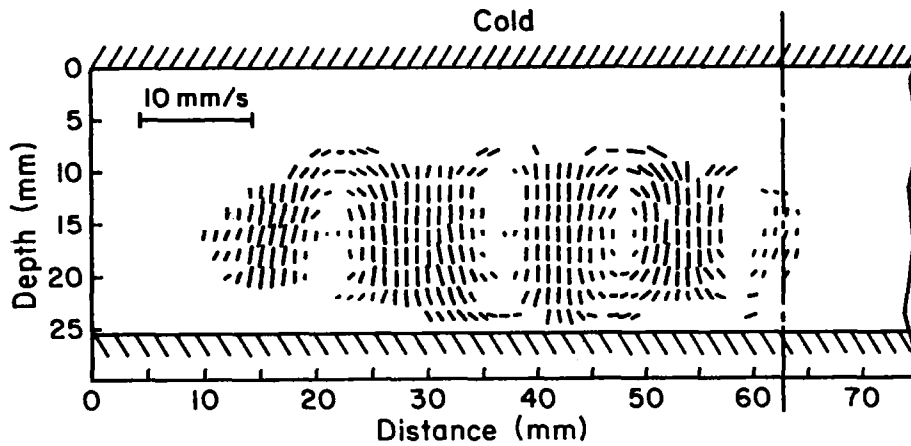
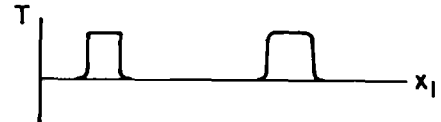
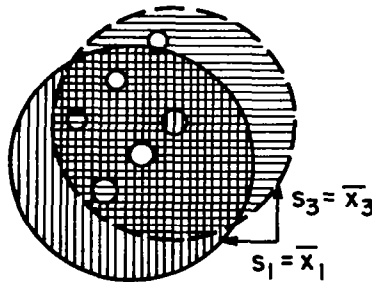

Figure 3.- Two-dimensional velocity field obtained in the unsteady Bénard convection experiment by Simpkins and Dudderar. (From P.G. Simpkins and T.D. Dudderar, Laser Speckle Measurements of Transient Bénard Convection, Journal of Fluid Mechanics, volume 89, part 4, by permission of Cambridge University Press.)

● Transmissivity of Specklegram = $T(x_1, x_3)$



● Correlation Concept



● $J(s_1, s_3) = \int I_0(x_1, x_3) T(x_1, x_3) T(x_1 + s_1, x_3 + s_3) dx_1 dx_3$
 = maximum when $(s_1, s_3) = (u_1 \Delta t, u_2 \Delta t)$

Figure 4.- Interrogation by 2-D correlation.

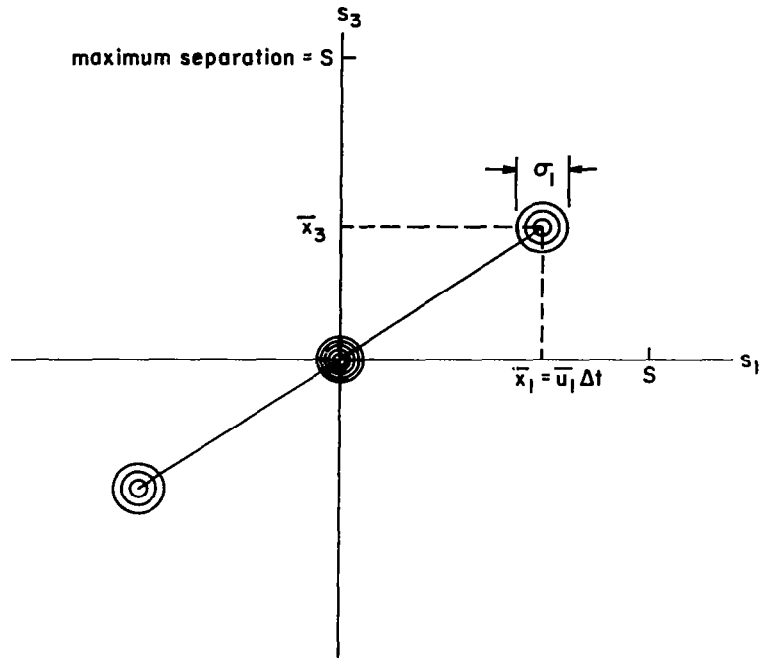

Velocity Resolution $\propto \sigma_1 / \bar{x}_1 > \sigma_1 / S$

Spatial Resolution $\propto S$

Figure 5.- Correlation plane.

- Mirror Deflection (1 ms/scan)
Polarization Splitter

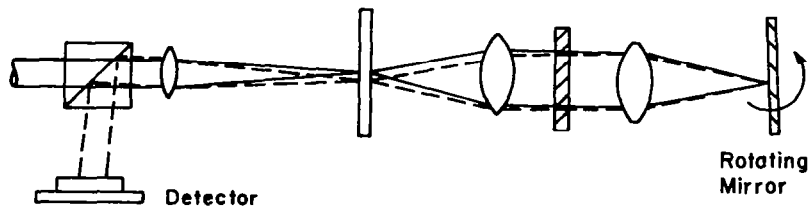

- Bragg Cell Deflection (1 μs/scan)

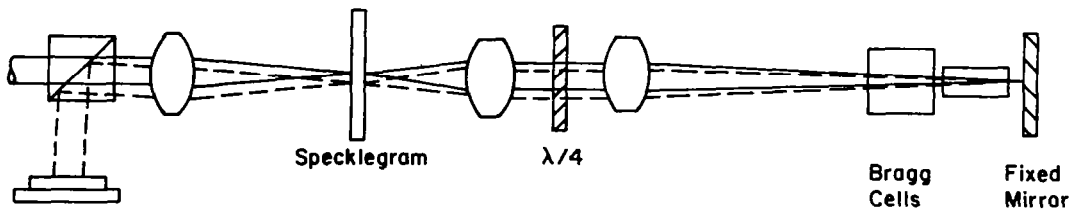
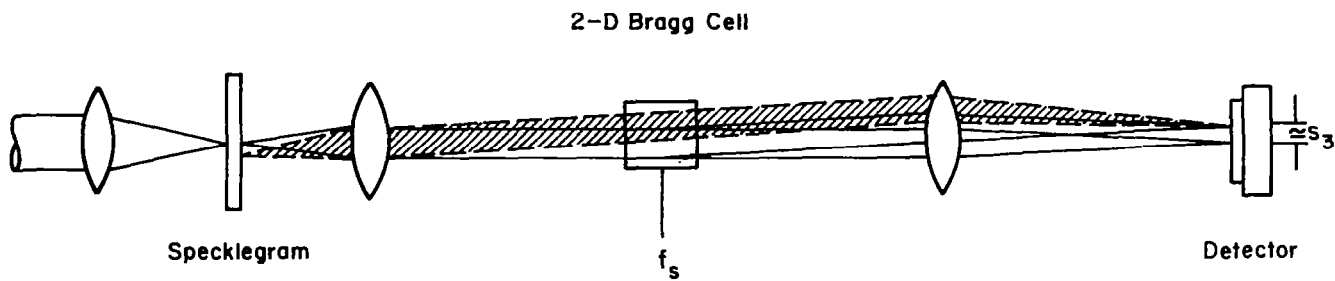

Figure 6.- Fast 2-D transmission correlation.



Maximum Heterodyne Signal Strength When $s_3 = \bar{x}_3$

Figure 7.- Fast 2-D heterodyne correlation.

0.2% full scale requires 512 x 256 points on the specklegram correlation if done blindly, e.g., 256 scans across s_1 with 512 points stored per scan.

Total time at 1 ms/scan = 0.25 s

Total data storage = 128 k words

Smart scanning - store (s_1, s_3) if J exceeds threshold.

Total data storage \cong 1 k words

Total time at 1 ms/scan \cong 0.25 s

Figure 8.- Correlation speed.

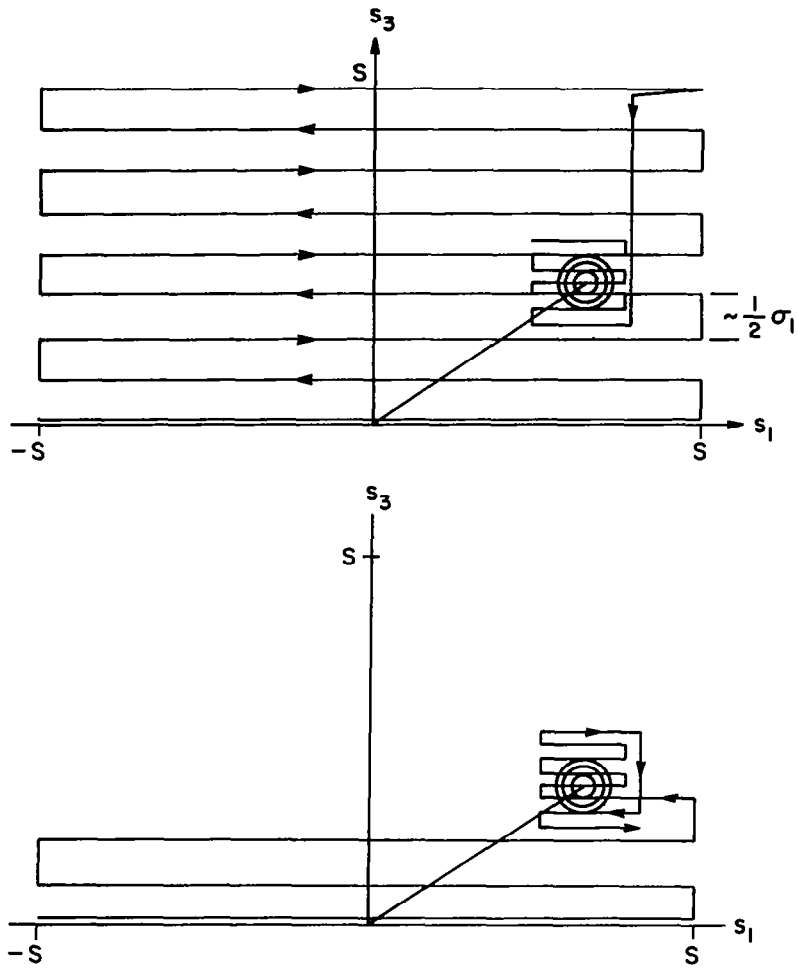
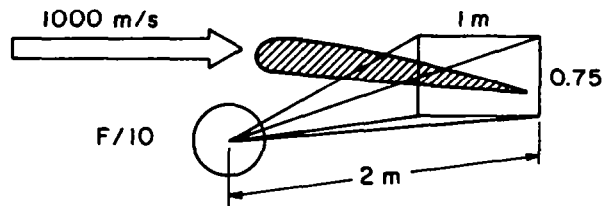

Figure 9.- Search methods.



Spatial Resolution: 10 mm

Temporal Resolution: $1 \mu\text{s} \pm 3 \text{ ns}$

Velocity Resolution: $\pm 0.6\%$ of full scale

Particle Resolution: $1.5 \mu\text{m}$

Figure 10.- Performance.