

**U.S. Department of Commerce
National Technical Information Service**



N83-11175

**SATELLITE SERVICES WORKSHOP VOLUME 1
FINAL REPORT**

**LYNDON B. JOHNSON SPACE CENTER
HOUSTON, TEXAS**

JUNE 82



National Aeronautics and
Space Administration

Lyndon B. Johnson Space Center
Houston, Texas 77058

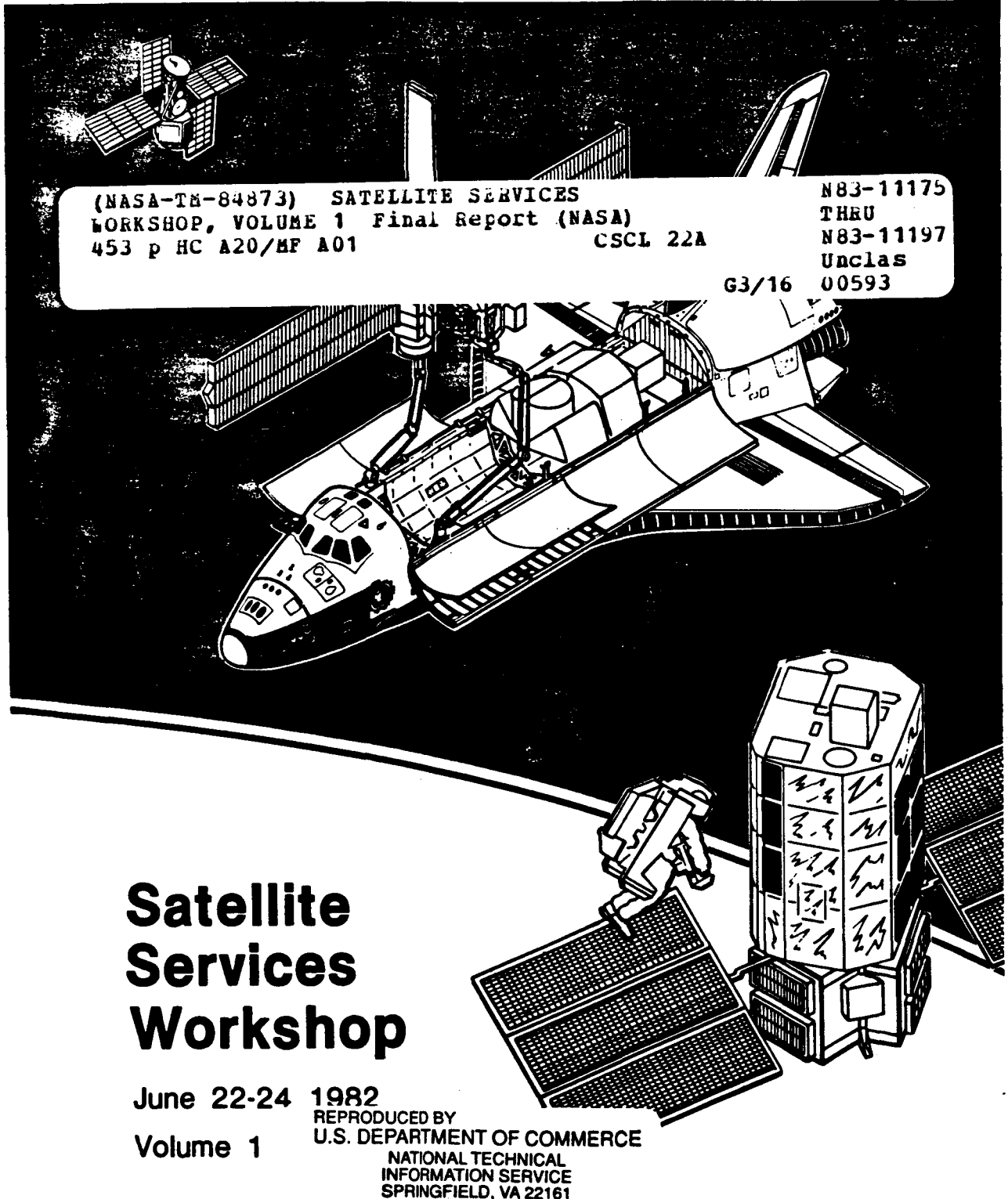

(NASA-TM-84873) SATELLITE SERVICES
WORKSHOP, VOLUME 1 Final Report (NASA)
453 p HC A20/MF A01 CACL 22A
N83-11175
THRU
N83-11197
Unclas
G3/16 00593

Satellite Services Workshop

June 22-24

1982

Volume 1

REPRODUCED BY
U.S. DEPARTMENT OF COMMERCE
NATIONAL TECHNICAL
INFORMATION SERVICE
SPRINGFIELD, VA 22161

SATELLITE SERVICES WORKSHOP

June 22, 23 & 24, 1982

Sponsored and Conducted

by

**NASA Lyndon B. Johnson Space Center
Engineering and Development Directorate**

**JSC Director : Christopher C. Kraft, Jr.
E&D Director : Robert O. Piland
Workshop Chairman : Clarke Covington
Workshop Organizer : Gordon Rysavy
Workshop Secretary : Joy L. Robertson**

This document consists of the presentations submitted at the Satellite Services Workshop. Its purpose is to provide a forum for the exchange of information and the identification of key issues associated with on-orbit servicing of satellites. Responsibility for content and technical accuracy lies with each respective author. Prior to formal publication elsewhere, the data presented herein may not be used without the author's permission.

**National Aeronautics and Space Administration
Lyndon B. Johnson Space Center
Houston, Texas 77058**

CONTENTS - VOLUME I

	<u>Page/Vol.</u>
Satellite Services System Overview by Gordon Rysavy (JSC)	Pg. 1
Servicing Equipment Session Chairman: John Mockovciak, Jr. Grumman Aerospace Corp.	
Advanced Service Equipment by J. Mockovciak, Jr. (GAC)	Vol. 2
Concept Definition for Proximity Operations Module by R. J. Adornato (GAC)	Vol. 2
Spacecraft Automatic Umbilical System. by G. C. Rudy (LMSC)	Vol. 2
Maneuverable Television. by R. H. Gerlach (JSC)	Vol. 2
The Role of the Shuttle Remote Manipulator in Satellite Servicing by B. R. Fuller (SPAR)	Pg. 10
Manned Maneuvering Unit. by F. Bergonz (MMC)	Pg. 32
Extravehicular Mobility Unit by K. R. King (Ham. Std.) M. N. Rouen (JSC)	Pg. 44
Teleoperator Maneuvering System. by J. R. Turner (MSFC)	Pg. 73
Space Operations Center Application of Satellite Service Equipment by R. W. McCaffrey (GAC)	Vol. 2
Remote Orbital Servicing System Concept. by A. J. Meintel (LaRC) R. T. Schappell (MMC)	Vol. 2

Servicing Operations Session
Chairman: Bruce McCandless, II.
Johnson Space Center

- On-Orbit EVA Operations Vol. 2
by J. McBride (JSC)
- Automated Rendezvous and Proximity Operations Pg. 110
by R. W. Becker (JSC)
R. L. Anderson (LinCom)
- Solar Maximum Observatory Repair Mission. Pg. 137
by G. P. Kenney (JSC)
- Co-Orbiting Mechanics Pg. 166
by L. E. Livingston (JSC)
- Payload Processing and Integration at KSC Pg. 182
by D. C. Moja (KSC)
- Advanced Extravehicular Mobility Unit Study Pg. 197
by W. Elkins (LSSI)
- Payload IVA Training and Simulation Pg. 215
by J. H. Monsees (LMSC)
- Open Cherry Picker Simulation Results Vol. 2
by C. A. Nathan (GAC)
- EVA Applications and Implementation Vol. 2
by J. R. Jaax (JSC)

Servicing Economics Session
Chairman: Jack Wohl
Lockheed Missiles & Space Co.

- Spacecraft Redundancy and Environmental Tests - A Historical
Evaluation Pg. 229
by V. S. Bollman (LMSC)
R. A. Blockinger (LMSC)
- Analysis of Satellite Servicing Cost Benefits Pg. 247
by H. O. Bulteman (LMSC)
- Representative Service Missions and Service Costs Vol. 2
by J. Mockovciak, Jr. (GAC)
- Servicing Economics for LANDSAT Vol. 2
by F. Cepollina (GSFC)

W

Satellite Design Session

Chairmen: J. L. Hieatt
TRW
Frank Cepollina
Goddard Space Flight Center

Design of the Materials Experiment Carrier for On-Orbit
Servicing Pg. 261
by D. M. Waltz (TRW)
H. F. Meissinger (TRW)

Design Considerations for On-Orbit Servicing Pg. 290
by H. T. Fisher (LMSC)

Multi-Mission Modular Spacecraft Vol. 2
by R. E. Davis (GSFC)

Electrophoresis Operations in Space. Pg. 307
by D. W. Richman (MDAC)

Space Platform Pg. 320
by E. E. Beam (MSFC)

Berthing/Docking Session
Chairman: W. K. Creasy
Johnson Space Center

Characteristics of the Handling and Positioning Aid. Vol. 2
by C. J. Goodwin (GAC)

Payload Retention System Vol. 2
by J. H. Hardee (RI)

Payload Installation and Deployment Aid. Pg. 335
by T. O. Ross (JSC)

Laser Docking Sensor Pg. 350
by H. O. Erwin (JSC)

Fluid Transfer Session
Chairman: W. E. Simon
Johnson Space Center

Fluids Management Technology Pg. 381
by J. M. McGee (JSC)

Orbiter OMS and RCS Technology Pg. 406
by R. A. Boudreaux (RI)

Cryogenic Fluid Transfer - Orbital Transfer Vehicle. Pg. 431
by L. J. Hastings (MSFC)

SATELLITE SERVICES SYSTEM OVERVIEW

GORDON RYSAVY
NASA JOHNSON SPACE CENTER
JUNE 22, 1982

FN 83 11176

21

NASA

Near Orbiter Satellite Services Elements

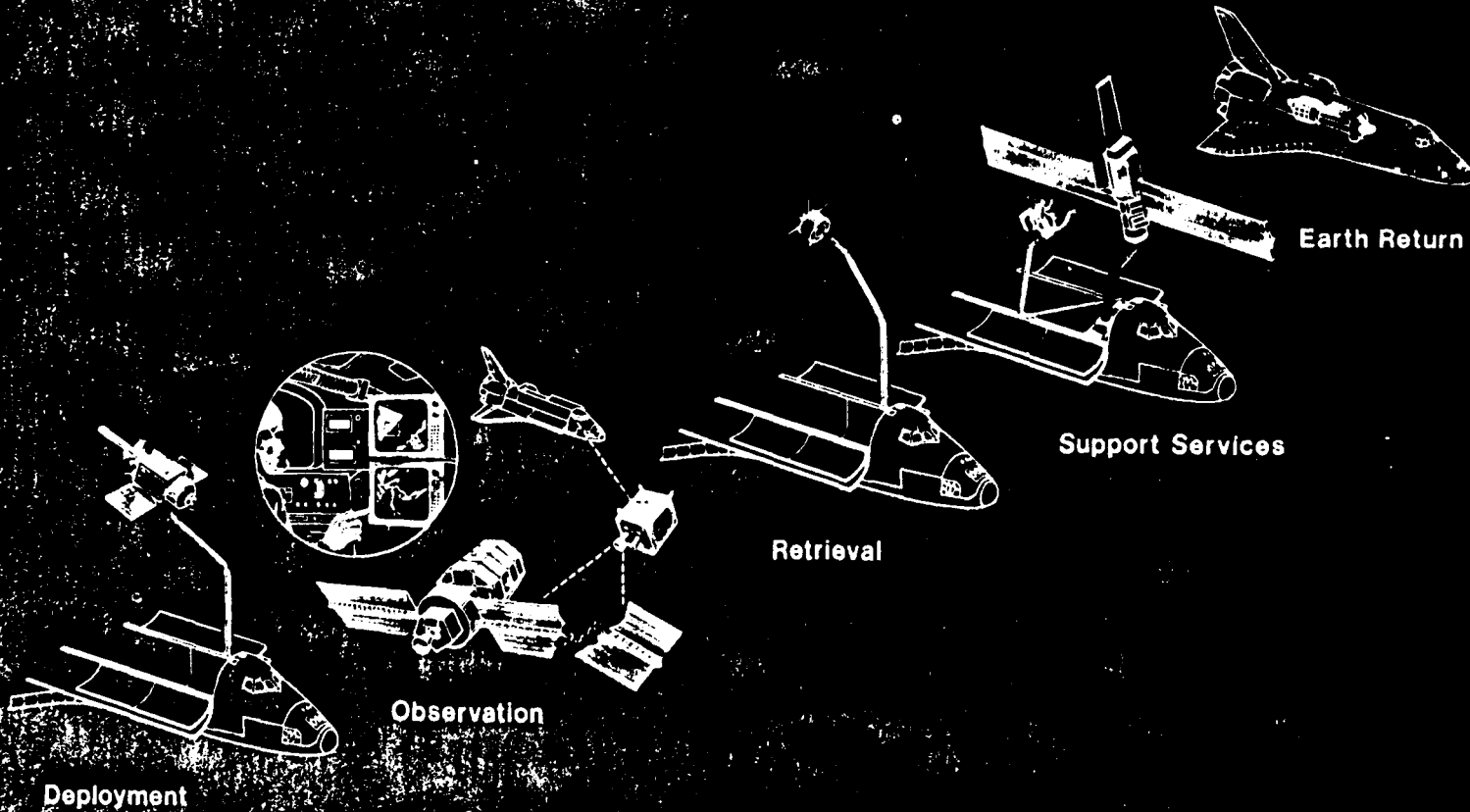

2

OFFICE 604
ORIGINAL PAGE
BLACK AND WHITE PHOTOGRAPH

NASA

Satellite
Services

an extension of the
Space Transportation
System

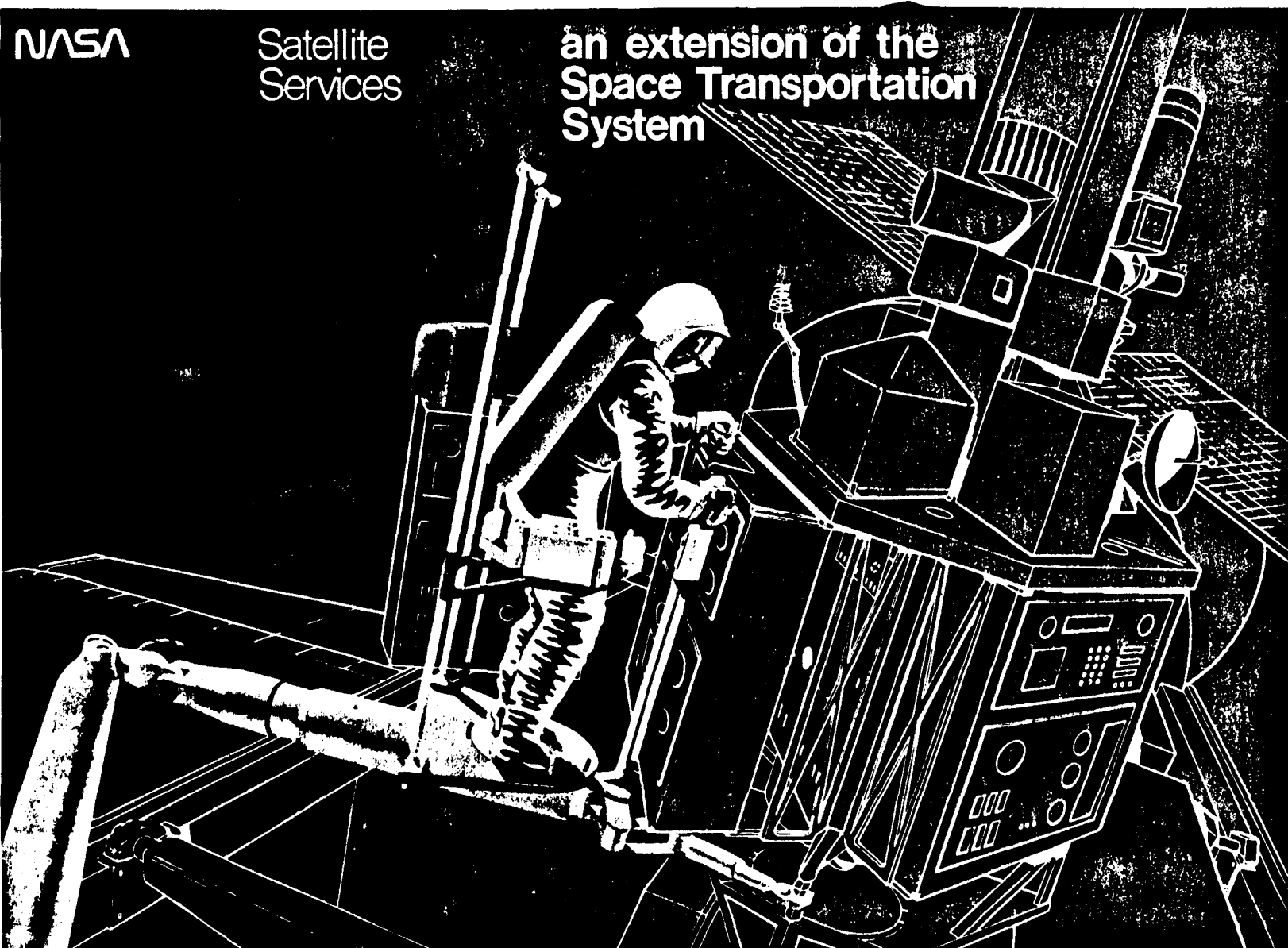

3

ORIGINAL PAGE
BLACK AND WHITE PHOTOGRAPH

SATELLITE SERVICES SYSTEM OVERVIEW

PROGRAM DEVELOPMENT OFFICE

G. RYSAVY

SOME ADVANTAGES/BENEFITS OF A SATELLITE SERVICES SYSTEM

- WILL EXTEND AND ENHANCE STS OPERATIONAL ON-ORBIT CAPABILITY
- WILL PROVIDE STANDARDIZATION OF EQUIPMENT
- WILL DEVELOP USER RECOGNITION FOR PLANNED SERVICING
- WILL PROVIDE SOME CAPABILITY FOR DEBRIS REMOVAL
- WILL PROVIDE POTENTIAL CONTINGENCY ACTIVITIES USAGE

BASIC IDENTIFIED NEEDS FOR STS TO HAVE IMPROVED SATELLITE SERVICE CAPABILITY

- ABILITY TO HAVE A STABLE WORK PLATFORM FOR MANNED EVA ANYWHERE WITHIN THE PAYLOAD BAY.
- ABILITY, WITH THE USE OF THE MANNED MANEUVERING UNIT (MMU), TO ATTACH TO SATELLITES/STRUCTURES AND HAVE A STABLE WORK PLATFORM.
- ABILITY TO OBSERVE WITH TV REMOTE FROM ORBITER.
- ABILITY TO TEMPORARILY HOLD AND POSITION SATELLITES/STRUCTURES.
- ABILITY TO TRANSFER FLUIDS TO SATELLITES.
- ABILITY TO INCREASE MANNED EVA PRODUCTIVITY THROUGH USE OF POWER TOOLS.

ORIGINAL PAGE IS
IF POOR QUALITY



INHERENT EQUIPMENT (EQUIPMENT INHERENT WITH STS SYSTEM)	PROGRAM DEVELOPMENT OFFICE	
	G. RYSAVY	

INHERENT SERVICING EQUIPMENT	SATELLITE SERVICE FUNCTION	STATUS
PAYLOAD RETENTION SYSTEM - PRS	<ul style="list-style-type: none"> ● PROVIDES ORBITER RETENTION (AND RELEASE) OF PAYLOADS. 	AVAILABLE
REMOTE MANIPULATOR SYSTEM - RMS	<ul style="list-style-type: none"> ● PRIMARILY FOR DEPLOYMENT AND RETRIEVAL OF SATELLITES; ALSO FOR OBSERVATION VIA CCTV AND SUPPORT SERVICES. 	AVAILABLE
EXTRAVEHICULAR MOBILITY UNIT (EMU)	<ul style="list-style-type: none"> ● PROVIDES MANNED EVA CAPABILITY. 	AVAILABLE
MANNED MANEUVERING UNIT - MMU	<ul style="list-style-type: none"> ● PROVIDES MANNED PROPULSIVE EVA CAPABILITY. 	AVAILABLE
ORBITER MANEUVERING SYSTEM KIT - OMS KIT	<ul style="list-style-type: none"> ● INCREASES ORBITER DELTA-V CAPABILITY. 	ON-HOLD
AFT FLIGHT DECK - CONTROLS AND DISPLAYS	<ul style="list-style-type: none"> ● PROVIDES CONTROL OF RMS, PRS AND OTHER REMOTE MECHANISMS FROM THE ORBITER AFT FLIGHT DECK. 	AVAILABLE
EXTRAVEHICULAR MOBILITY UNIT TV	<ul style="list-style-type: none"> ● PROVIDES CCTV DURING EVA. 	AVAILABLE
CLOSED-CIRCUIT TELEVISION - CCTV	<ul style="list-style-type: none"> ● PROVIDES CCTV VIEWING OF CARGO BAY. 	AVAILABLE
ORBITER EXTERIOR LIGHTING	<ul style="list-style-type: none"> ● PROVIDES LIGHTING OF CARGO BAY. 	AVAILABLE
EQUIPMENT STOWAGE	<ul style="list-style-type: none"> ● PROVIDES FOR THE STOWAGE OF EQUIPMENT, SPARE PARTS, TOOLS AND DEBRIS. 	PARTIALLY AVAILABLE

ORIGINAL PAGE IS OF POOR QUALITY

5

GENERIC EQUIPMENT (EQUIPMENT WHICH INTEGRATES WITH THE INHERENT EQUIPMENT AND HAS GROWTH POTENTIAL)

PROGRAM DEVELOPMENT OFFICE

G. RYSAVY

GENERIC SERVICING EQUIPMENT

SATELLITE SERVICE FUNCTION

STATUS

MANIPULATOR FOOT RESTRAINT - MFR

- PROVIDES A STABLE PLATFORM FOR MANNED ACTIVITY WITHIN OPERATING RANGE OF RMS.

DEVELOPMENT COMPLETED. FUNDING FOR FLIGHT HARDWARE PENDING.

WORK RESTRAINT UNIT - WRU

- PROVIDES A METHOD OF SATELLITE ATTACHMENT AND A STABLE WORK RESTRAINT DURING MMU ACTIVITY.

DEVELOPMENT PARTIALLY COMPLETE.

MANEUVERABLE TELEVISION - MTV

- PROVIDES REMOTE SATELLITE (AND ORBITER) OBSERVATION CAPABILITY.

LIMITED DEVELOPMENT ACTIVITY UNDERWAY.

HOLDING AND POSITIONING AID - HPA

- PROVIDES TEMPORARY HOLDING AND POSITIONING OF A SATELLITE WHILE BEING SERVICED

FABRICATION OF TEST MODEL FOR 1-G TESTING UNDERWAY.

FLUID TRANSFER EQUIPMENT/TECHNIQUES

- PROVIDES CAPABILITY TO TRANSFER FLUIDS BETWEEN THE ORBITER AND SATELLITES.

CONCEPT ONLY

POWER AND HAND TOOLS

- ENHANCES MANNED ACTIVITY DURING EVA.

PARTIALLY AVAILABLE

9

ORIGINAL PAGE IS
OF POOR QUALITY

UNIQUE EQUIPMENT (EQUIPMENT UNIQUE TO SPECIAL MISSION REQUIREMENT)		PROGRAM DEVELOPMENT OFFICE
		G. RYSAVY
UNIQUE SERVICING EQUIPMENT	SATELLITE SERVICE FUNCTION	STATUS
PAYLOAD INSTALLATION AND DEPLOYMENT AID	<ul style="list-style-type: none"> ● ALLOWS CONTROLLED DEPLOYMENT AND STOWAGE OF MAXIMUM SIZED PAYLOADS WITH MINIMAL RISK OF DAMAGE TO THE ORBITER AND PAYLOAD. 	1-G TEST MODEL EVALUATED.
PAYLOAD HANDLING DEVICES	<ul style="list-style-type: none"> ● PROVIDES CAPABILITY TO GRAPPLE AND HANDLE UNATTACHED PAYLOADS. 	STUDY UNDERWAY FOR SOLAR MAX REPAIR MISSION.
RMS SPECIAL PURPOSE END EFFECTORS	<ul style="list-style-type: none"> ● ENHANCES THE CAPABILITY OF THE RMS. 	CONCEPT ONLY
TILT TABLE	<ul style="list-style-type: none"> ● PROVIDES THE PROPER ORIENTATION OF PAYLOADS FOR DEPLOYMENT, BERTHING AND/OR SERVICING. 	CONCEPT ONLY
SPIN TABLE	<ul style="list-style-type: none"> ● PROVIDES THE CAPABILITY TO "SPIN-UP" SATELLITE PRIOR TO DEPLOYMENT. 	CONCEPT ONLY

ORIGINAL PAGE IS
OF POOR QUALITY

7

ADVANCED EQUIPMENT (EQUIPMENT POTENTIALLY NEEDED TO FULFILL FUTURE MISSION MODEL REQUIREMENTS)		PROGRAM DEVELOPMENT OFFICE	
		G. RYSAVY	
ADVANCED SERVICING EQUIPMENT	SATELLITE SERVICE FUNCTION	STATUS	
TELEOPERATOR MANEUVERING SYSTEM	<ul style="list-style-type: none"> ● PROVIDES FOR PAYLOAD DELIVERY/RETRIEVAL TO/FROM SATELLITE OPERATIONAL ORBIT WHEN DIFFERENT FROM ORBITER ORBIT. 	STUDIES UNDERWAY	
NON-CONTAMINATING ATTITUDE CONTROL SYSTEM	<ul style="list-style-type: none"> ● ALLOWS SERVICING OF CONTAMINATION SENSITIVE SATELLITES. 	CONCEPT ONLY	
SUN SHIELD	<ul style="list-style-type: none"> ● PROVIDES PROTECTION TO SUN SENSITIVE PAYLOAD. 	CONCEPT ONLY	
ORBITAL STORAGE	<ul style="list-style-type: none"> ● PROVIDES ENVIRONMENTAL PROTECTION FOR ON-ORBIT QUIESCIENT "STORAGE" OF SATELLITES. 	CONCEPT ONLY	
OPTICAL ATTITUDE TRANSFER SYSTEM	<ul style="list-style-type: none"> ● MEASURES PAYLOAD BAY DISTORTION RELATIVE TO THE INERTIAL MEASUREMENT UNIT (IUM) PLATFORM, HENCE TRANSFERRING ATTITUDE REFERENCE TO SATELLITES MORE ACCURATELY. 	CONCEPT ONLY	
LIGHTING ENHANCEMENT	<ul style="list-style-type: none"> ● ENHANCES LIGHTING CAPABILITY. 	CONCEPT ONLY	
DEXTEROUS MANIPULATOR	<ul style="list-style-type: none"> ● ENHANCES REMOTE "TELEOPERATOR" SERVICE CAPABILITY. 	LIMITED STUDY UNDERWAY	
DE-ORBIT PROPULSION PACKAGE	<ul style="list-style-type: none"> ● PROVIDES THE CAPABILITY TO DE-ORBIT AND PROPEL EXPENDABLE SATELLIES TO EARTH. 	CONCEPT ONLY	

③

ORIGINAL PAGE IS
OF POOR QUALITY

SATELLITE SERVICES SYSTEM OVERVIEW
EVOLUTIONARY GROWTH POTENTIAL

PROGRAM DEVELOPMENT OFFICE

GORDON RYSAVY

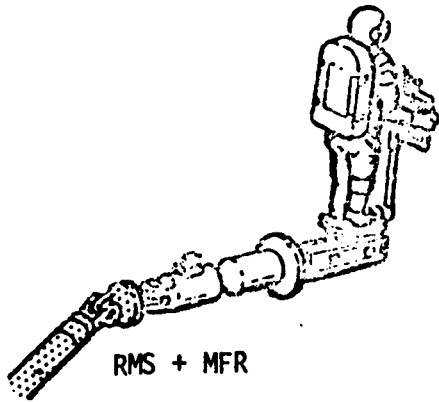

RMS + MFR

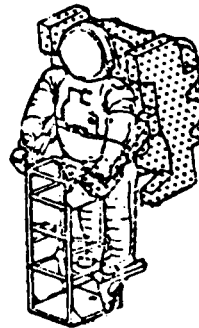

MMU + WRU

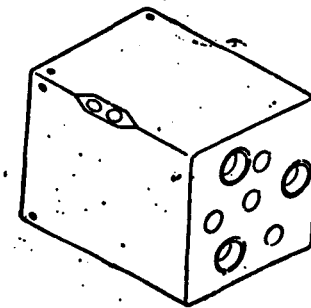

CCTV + MTV

ORIGINAL PAGE IS
OF POOR QUALITY

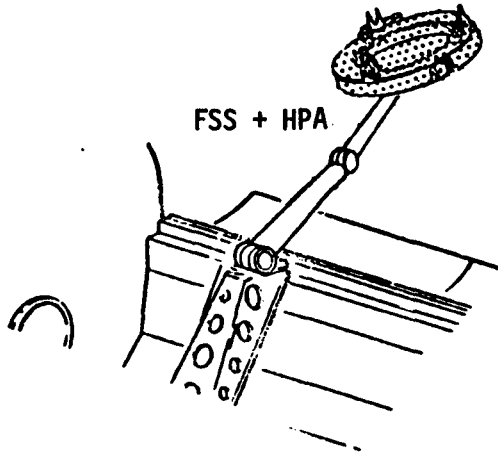

FSS + HPA

LIMITED EXPENDABLES
+ FLUID TRANSFER

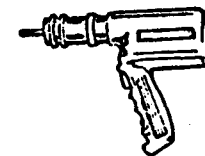
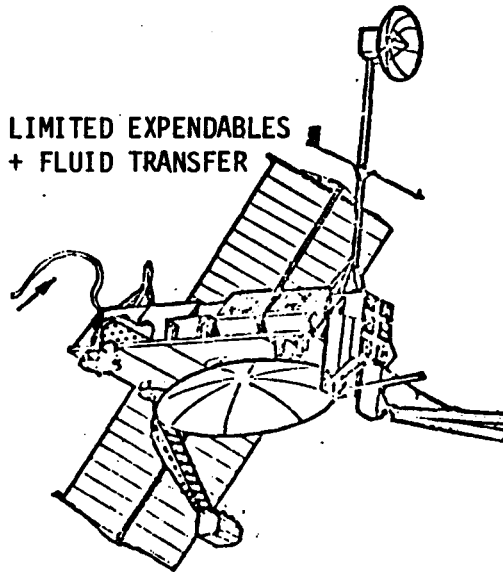

HAND TOOLS +
POWER TOOLS

**THE ROLE OF THE
SHUTTLE REMOTE
MANIPULATOR SYSTEM
IN
SATELLITE SERVICING**



A PRESENTATION BY SPAR AEROSPACE

JUNE, 1982

025
N83
11177

ORIGINAL PAGE IS
OF POOR QUALITY

Spar Aerospace Limited
Remote Manipulator Systems Division
1700 Ormont Drive, Weston, Ontario, Canada M9L 2W7



**Space &
Electronics Group**

TEL (416) 745-9680

TELEX 065-27360 SPARORM TOR

TWX 610-491-1503

CABLE-SPARORM TOR

10

1



SRMS BASIC DESCRIPTION

SRMS SERVICING ROLE

SRMS POTENTIAL GROWTH

UNIVERSAL SERVICE TOOL CONCEPT

ORIGINAL PAGE IS
OF POOR QUALITY

//



SHUTTLE RMS

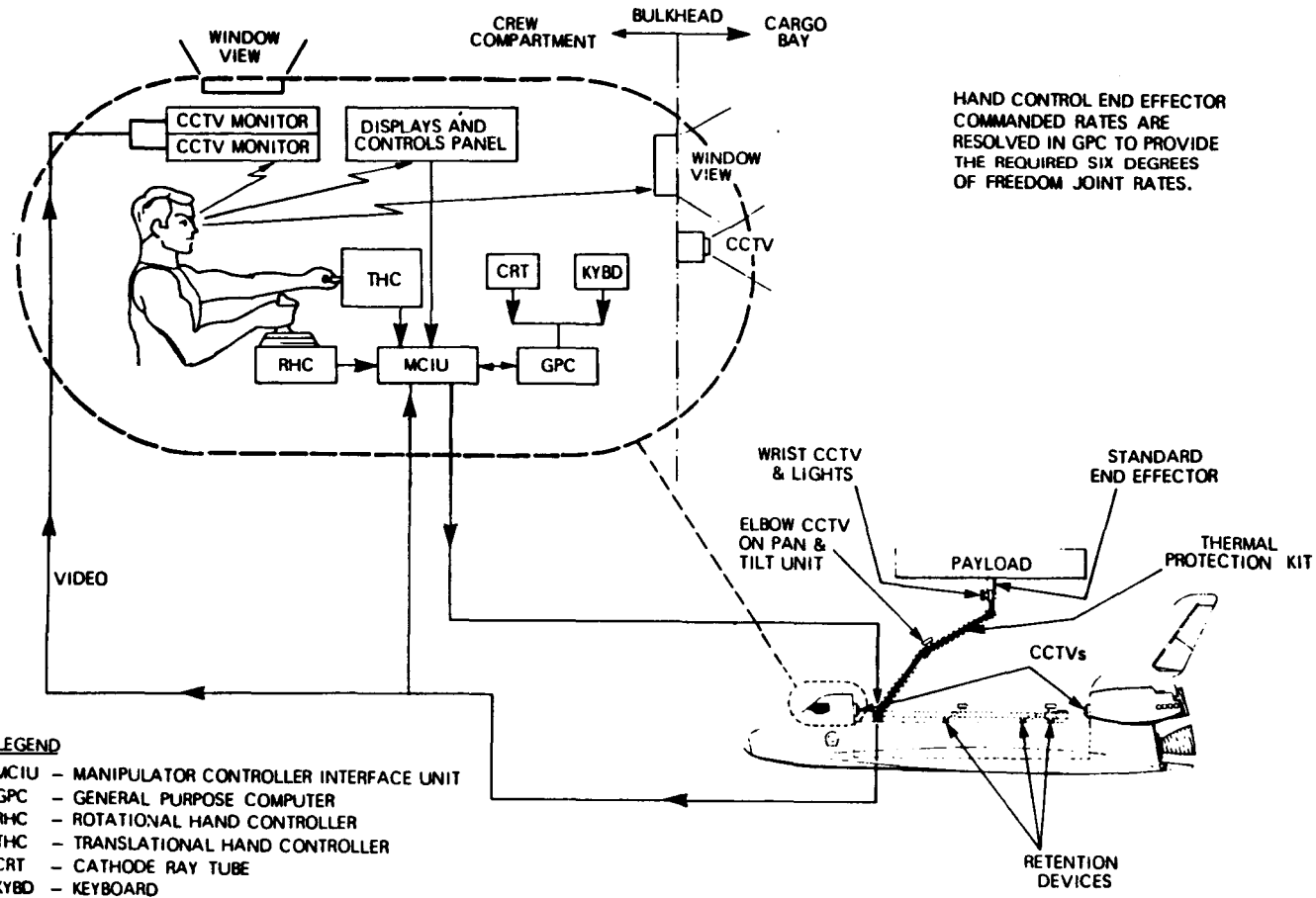

12

ORIGINAL PAGE IS
OF POOR QUALITY



THE ROLE OF SRMS IN SATELLITE SERVICING



SRMS SYSTEM

THE SHUTTLE REMOTE MANIPULATOR SYSTEM (SRMS) COMPRISES:

STANDARD CONFIGURATION:

- MANIPULATOR ARM INSTALLED ON PORT LONGERON
- WRIST CCTV CAMERA AND LIGHT
- STANDARD END EFFECTOR (SEE) WITH ELECTRICAL CONNECTOR & EVA HAND HOLD

OPTIONS

- SECOND ARM INSTALLED ON STARBOARD LONGERON
- ELBOW CCTV CAMERA WITH PAN & TILT UNIT
- SPECIAL PURPOSE END EFFECTORS
- SPECIAL PURPOSE GRAPPLE FIXTURES



SRMS BASIC DESCRIPTION

SRMS SERVICING ROLE

SRMS POTENTIAL GROWTH

UNIVERSAL SERVICING TOOL CONCEPT

14



THE ROLE OF SRMS IN SATELLITE SERVICING

SPAR

SRMS TASKS

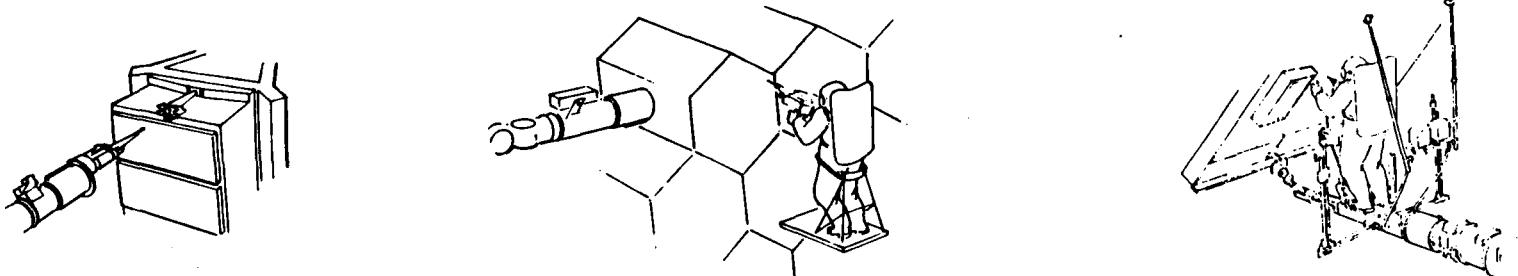
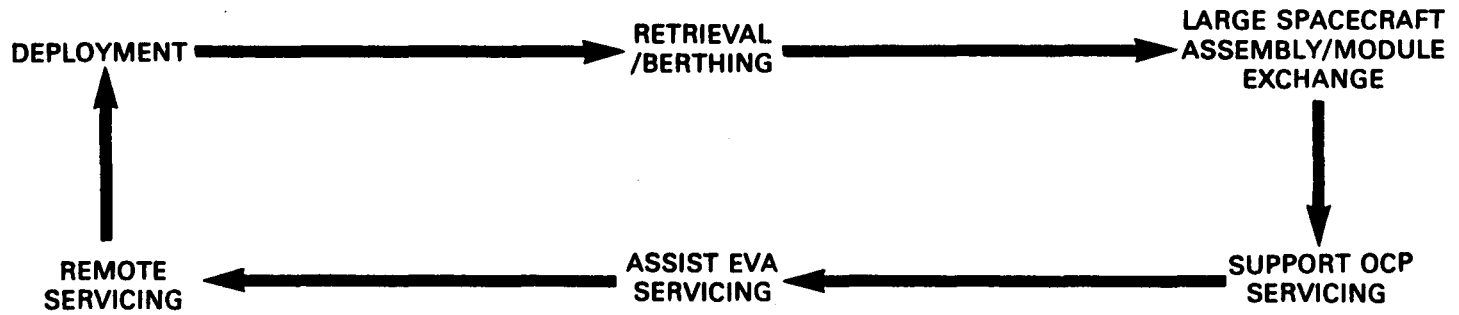
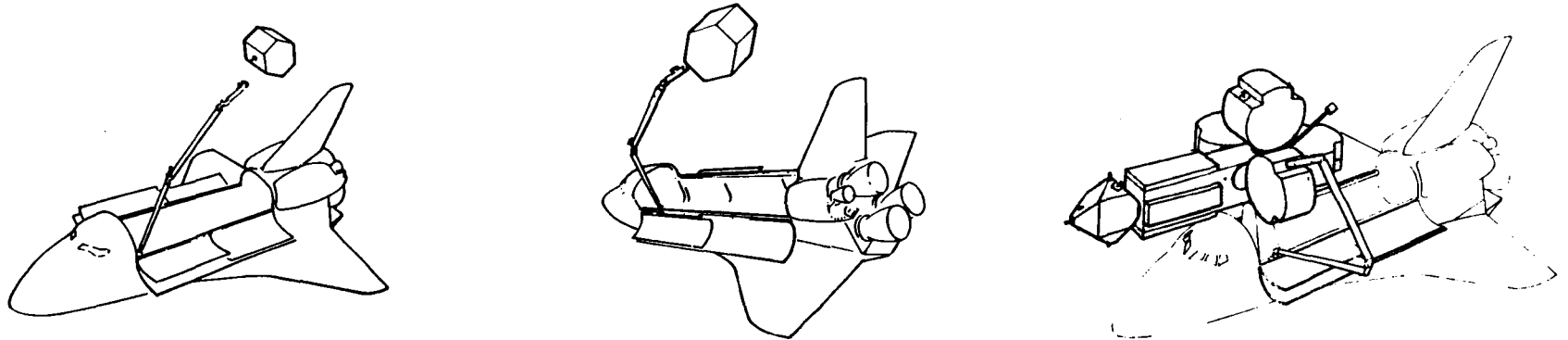

15

ORIGINAL PAGE IS
OF POOR QUALITY



SRMS TASKS

- DEPLOYMENT – 65,000 LB. PAYLOAD BASELINE

- RETRIEVAL – 32,000 LB. PAYLOAD BASELINE
– 65,000 LB. CONTINGENCY CAPABILITY

- SPACECRAFT ASSEMBLY/MODULE EXCHANGE
(Under Evaluation for 25 kW Power System/Power Utilization Package and
Space Operations Center)

- SUPPORT ASTRONAUT SERVICING (Baseline for OCP)

- REMOTE SERVICING – USING SRMS SUPPORTED TOOLING



THE ROLE OF SRMS IN SATELLITE SERVICING

SPAR

DEPLOYMENT

- THE SRMS IS DESIGNED TO DEPLOY AND RELEASE PAYLOADS WITH AN ATTITUDE ACCURACY OF $\pm 5^\circ$ AND A TIP-OFF RATE $< 0.015^\circ/\text{SEC.}$ WRT ORBITER.
- A CAPABILITY TO DEPLOY SPINNING PAYLOADS E.G. UNIVERSITY OF IOWA PDP.
- A CAPABILITY TO DEPLOY SATELLITES WITH AN INITIAL VELOCITY UP TO 1 FT/SEC. THIS REQUIRES FURTHER EVALUATION. PRESENT OPERATING CONSTRAINTS NECESSARY TO ENSURE A 2 FT. MAXIMUM STOPPING DISTANCE WOULD ALLOW RELEASE AT TYPICALLY 0.1 FT/SEC. FOR A 32,000 LB. PAYLOAD.

17



TYPICAL ARM CONFIGURATION FOR PAYLOAD RELEASE WITH A ΔV

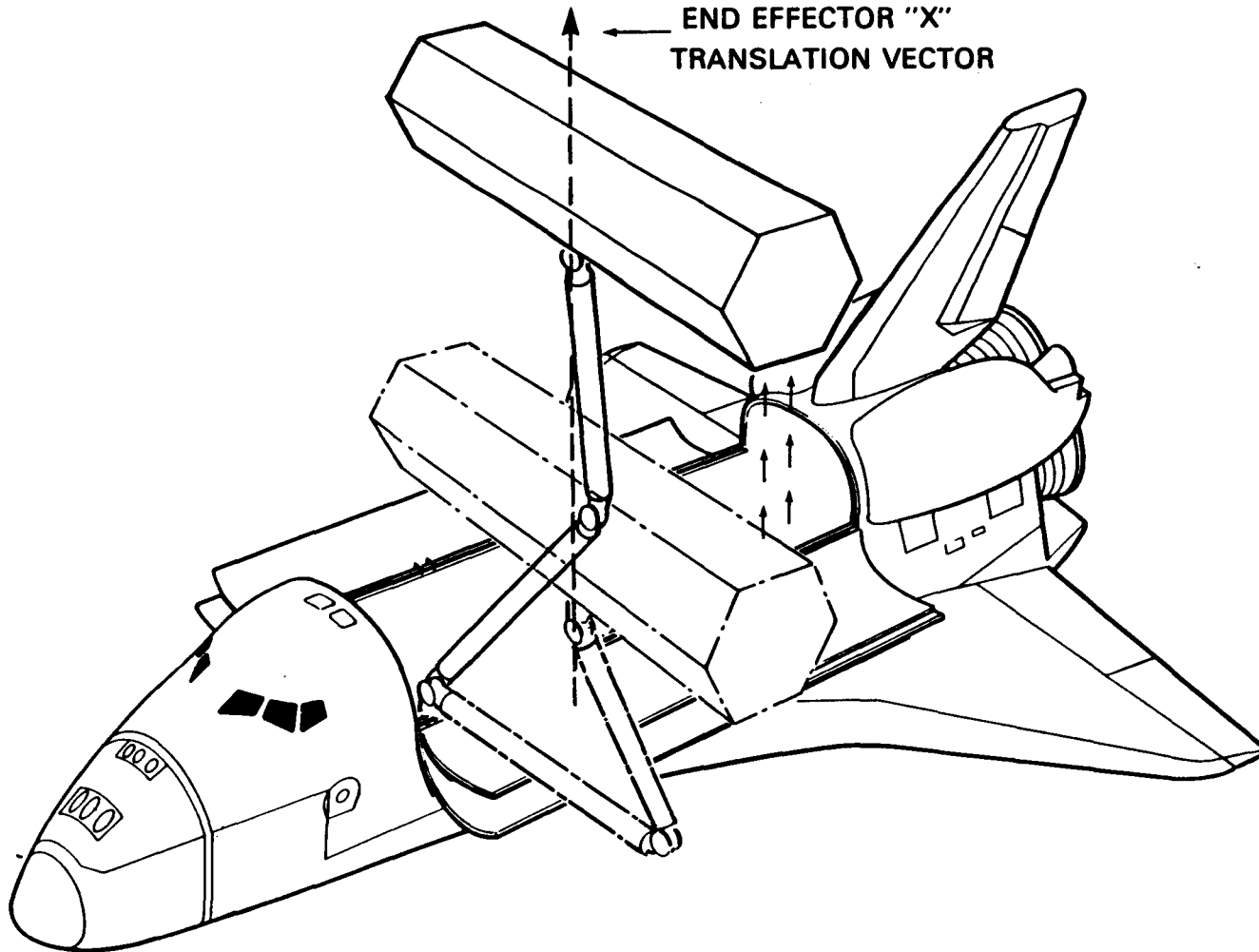

ORIGINAL PAGE IS
OF POOR QUALITY

18



RETRIEVAL/BERTHING

SRMS WITH THE STANDARD END EFFECTOR CAN INTERFACE MECHANICALLY WITH ANY NON-SPINNING SATELLITE WHICH HAS A COMPATIBLE GRAPPLE FIXTURE. PRESENT CAPTURE CONSTRAINTS FOR RELATIVE TRANSLATIONAL AND ROTATIONAL VELOCITY BETWEEN ORBITER AND SATELLITE ARE 0.1 FT/SEC. AND $\pm 1^\circ/\text{SEC}$. IN ANY AXIS.

- PRESENT GRAPPLE FIXTURES AVAILABLE ARE:
 - STANDARD GRAPPLE FIXTURE – SUITABLE FOR CAPTURE OF A PAYLOAD UP TO 65,000 LB.
 - ELECTRICAL GRAPPLE FIXTURE – CAPABLE OF HANDLING SMALL PAYLOADS.
- GRAPPLE FIXTURES OPTIMIZED FOR SPECIFIC PAYLOADS CAN BE SUPPLIED BY SPAR.
- A SPINNING END EFFECTOR CAPABLE OF DEPLOYING RETRIEVING AND DESPINNING SATELLITES UP TO 16,000 LBS. MASS IS IN THE FEASIBILITY STUDY STAGE AT SPAR.
- BERTHING IS ASSISTED WITH PAYLOAD MARKINGS AND TRUNNION GUIDE MARKINGS. USING GOOD VISUAL CUES ± 1 INCH $\pm 1^\circ$ POSITIONING ACCURACIES CAN BE ACHIEVED.

61



STANDARD GRAPPLE FIXTURE

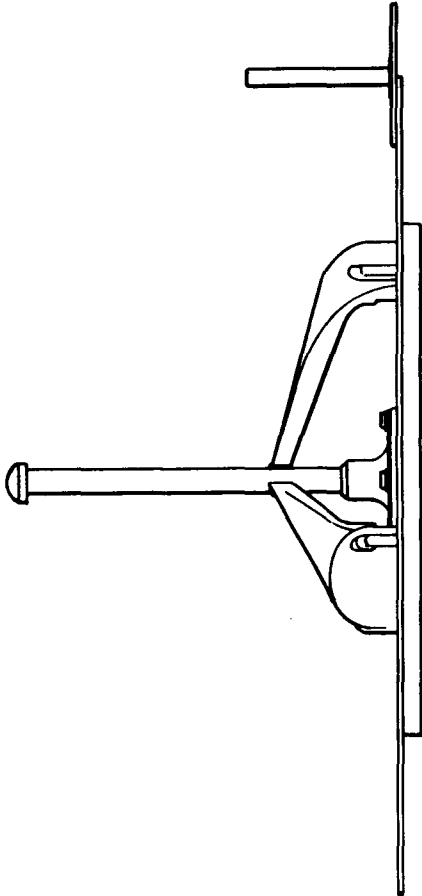

20

ELECTRICAL GRAPPLE FIXTURE

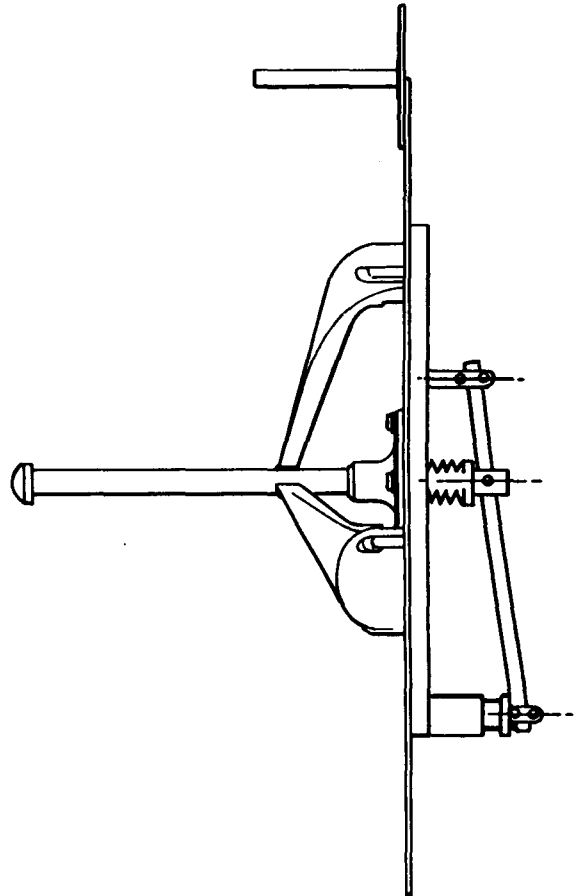

ORIGINAL PAGE IS
OF POOR QUALITY



THE ROLE OF SRMS IN SATELLITE SERVICING

SPAR

SUPPORT ASTRONAUT SERVICING

- INSPECTION TO ASSESS EVA REQUIREMENTS (TOOLS & EQUIPMENT).
- DEPLOY, MANOEUVRE AND POSITION A WORK STATION
- DEPLOY, MANOEUVRE AND POSITION MODULES FOR FURTHER SERVICING TASKS BY THE ASTRONAUT

21



REMOTE SERVICING

- **INSPECTION.**
- **REPLACEMENT OF EXPENDED AND FAULTY MODULES.**
- **REMOVAL AND ATTACHMENT TO REPLENISHMENT EQUIPMENT.**
- **THE SRMS CAN HANDLE MODULES UNSUITABLE FOR ASTRONAUT HANDLING (SIZE, INERTIA, RADIOACTIVE, ETC.)**
- **FACILITATED BY SPECIAL END EFFECTOR – PICKED UP BY STANDARD END EFFECTOR ON ORBIT
– ATTACHED TO SRMS PRIOR TO LAUNCH**

22



THE ROLE OF SRMS IN SATELLITE SERVICING

SPAR

SRMS BASIC DESCRIPTION

SRMS SERVICING ROLE

SRMS POTENTIAL GROWTH

UNIVERSAL SERVICE TOOL CONCEPT



SRMS POTENTIAL GROWTH - INCREASE IN UTILIZATION

- | | |
|--|--|
| DUAL ARM OPERATION
(SRMS is designed to operate 2 arms
in series) | - MAXIMIZE UTILIZATION OF EXISTING HARDWARE |
| REMOTE MOUNTED SRMS | - SPACE OPERATIONS CENTRE APPLICATIONS |
| ΔV PAYLOAD DEPLOYMENT | - MEET VOL XIV SATELLITE DEPLOYMENT
REQUIREMENTS WITHOUT USING SPACECRAFT
OR ORBITER CONSUMABLES |
| SPIN/DESPIN RETRIEVAL/DEPLOYMENT
(Currently under study at SPAR) | - PROVIDE STANDARD END EFFECTOR WITH A
"SPIN" JOINT OR A SPECIAL PURPOSE END
EFFECTOR |
| UNIVERSAL SERVICE TOOL | - PROVIDE A BASIC REMOTE SERVICING
CAPABILITY |

24



POTENTIAL SRMS GROWTH – PERFORMANCE IMPROVEMENTS

**IMPROVED POSITIONING
ACCURACY**

- INCORPORATE SOFTWARE FOR INTER-
FACE WITH PHOTOGRAMMETRY HARD-
WARE WHICH USES WRIST OR ORBITER
CAMERAS TO PROVIDE OPERATOR WITH
RELATIVE POSITION AND RATE DATA.

**IMPROVE SRMS/PAYLOAD
ELECTRICAL INTERFACE**

- MODIFY STANDARD END EFFECTOR
WITH AN "ACTIVE" ELECTRICAL
CONNECTOR TO INCREASE NUMBER
OF SIGNALS ACCOMMODATED ON
PAYLOAD/SRMS ELECTRICAL
INTERFACE.

**ADDITION OF AN UPPER ARM
ROLL JOINT**

- ELIMINATE PRESENT SINGULARITIES
IMPROVE OBSTACLE CLEARANCE
CAPABILITY INCREASE/IMPROVE
REACH.

**END POINT FORCE SENSING/
FEEDBACK (Currently under
investigation at SPAR)**

- IMPROVE HANDLING PRECISION

25



SPECIAL PURPOSE END EFFECTOR APPLICATIONS

- **DEPLOYMENT AND RETRIEVAL**
 - STABLE NON-SPINNERS
 - STABLE SPINNERS
 - UNSTABLE/UNCO-OPERATIVE
 - DEBRIS COLLECTORS

- **SPECIAL HANDLING**
 - SPECIFIC SHAPES OR STRUCTURE
 - IRREGULAR, HOLLOW, CONVEX, CONCAVE

- **PAYLOAD SERVICING**
 - LATCHING/DELATCHING
 - TORQUING (WRENCH, SCREW DRIVER)
 - ROTARY/POWER TOOLS (CUTTER, DRILL)
 - REPLENISHMENT OPERATIONS

26



THE ROLE OF SRMS IN SATELLITE SERVICING

SPAR

SRMS BASIC DESCRIPTION

SRMS SERVICING ROLE

SRMS POTENTIAL GROWTH

UNIVERSAL SERVICE TOOL CONCEPT

27



UNIVERSAL SERVICE TOOL SYSTEM (USTS) FOR ON-ORBIT SPACE SYSTEM SERVICING

- A VERSATILE SERVICE TOOL SYSTEM:
 - MODULAR DESIGN ACCOMMODATING SIMPLE CHANGE-OUT TOOLS,
MANIPULATOR AND OPERATOR INTERFACES
 - VARIABLE TORQUE CAPABILITY
- A MODE OF OPERATION FOR SRMS REMOTE SERVICING (USING SPEE CONNECTOR FOR ELECTRICAL POWER AND CONTROL INTERFACING).
- A MODE OF OPERATION FOR ASTRONAUT EVA (MANUAL OPERATION OF TOOL AND LATCH DRIVES AND TOOL INTERCHANGE).
- MINIMUM PAYLOAD INTERFACE ENVELOPE
- WEIGHT EFFECTIVE DESIGN.

29



THE ROLE OF SRMS IN SATELLITE SERVICING



UNIVERSAL SERVICE TOOL SYSTEM

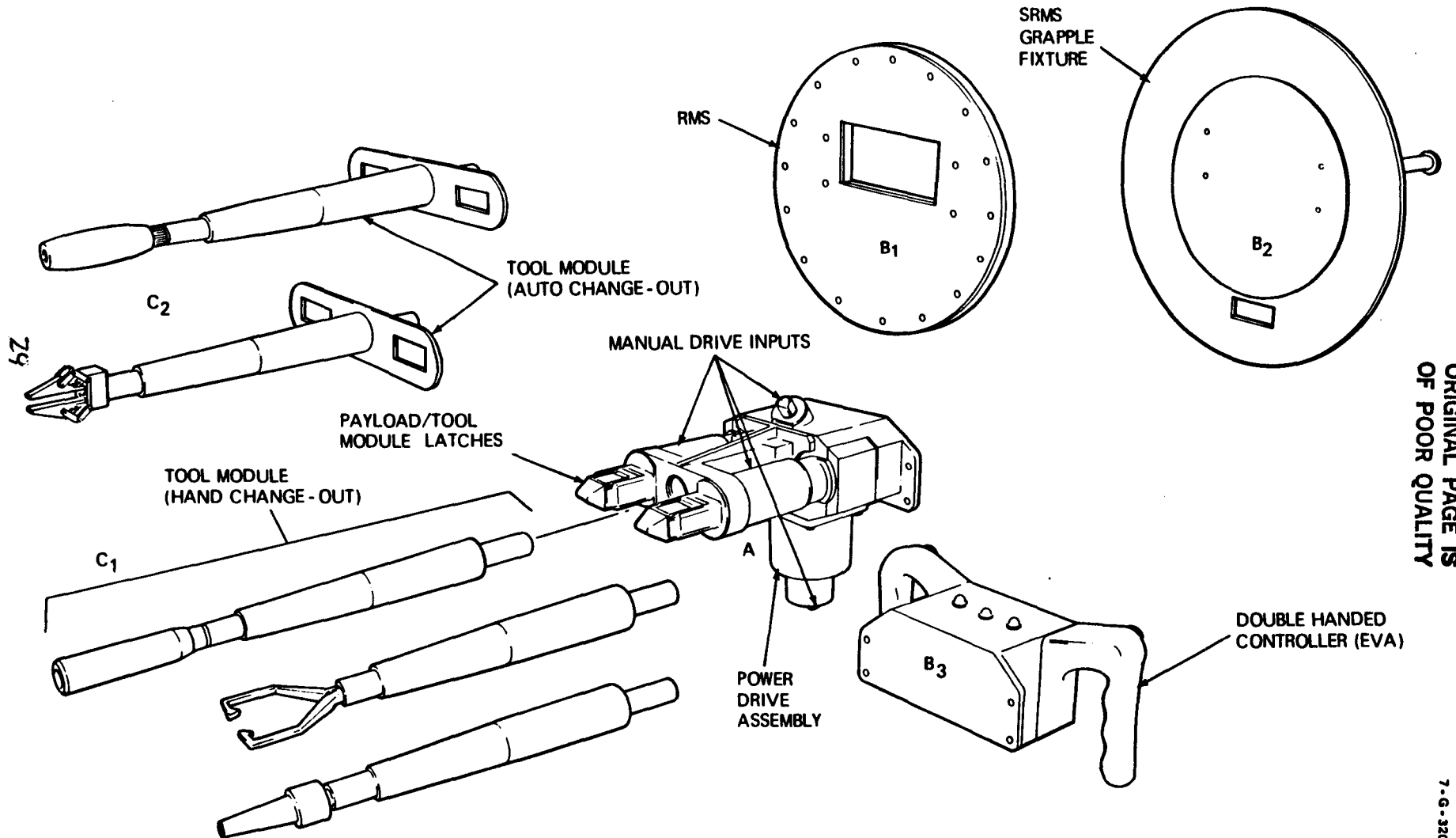

ORIGINAL PAGE IS
OF POOR QUALITY



UNIVERSAL SERVICE TOOL SYSTEM (USTS) CONCEPT

30

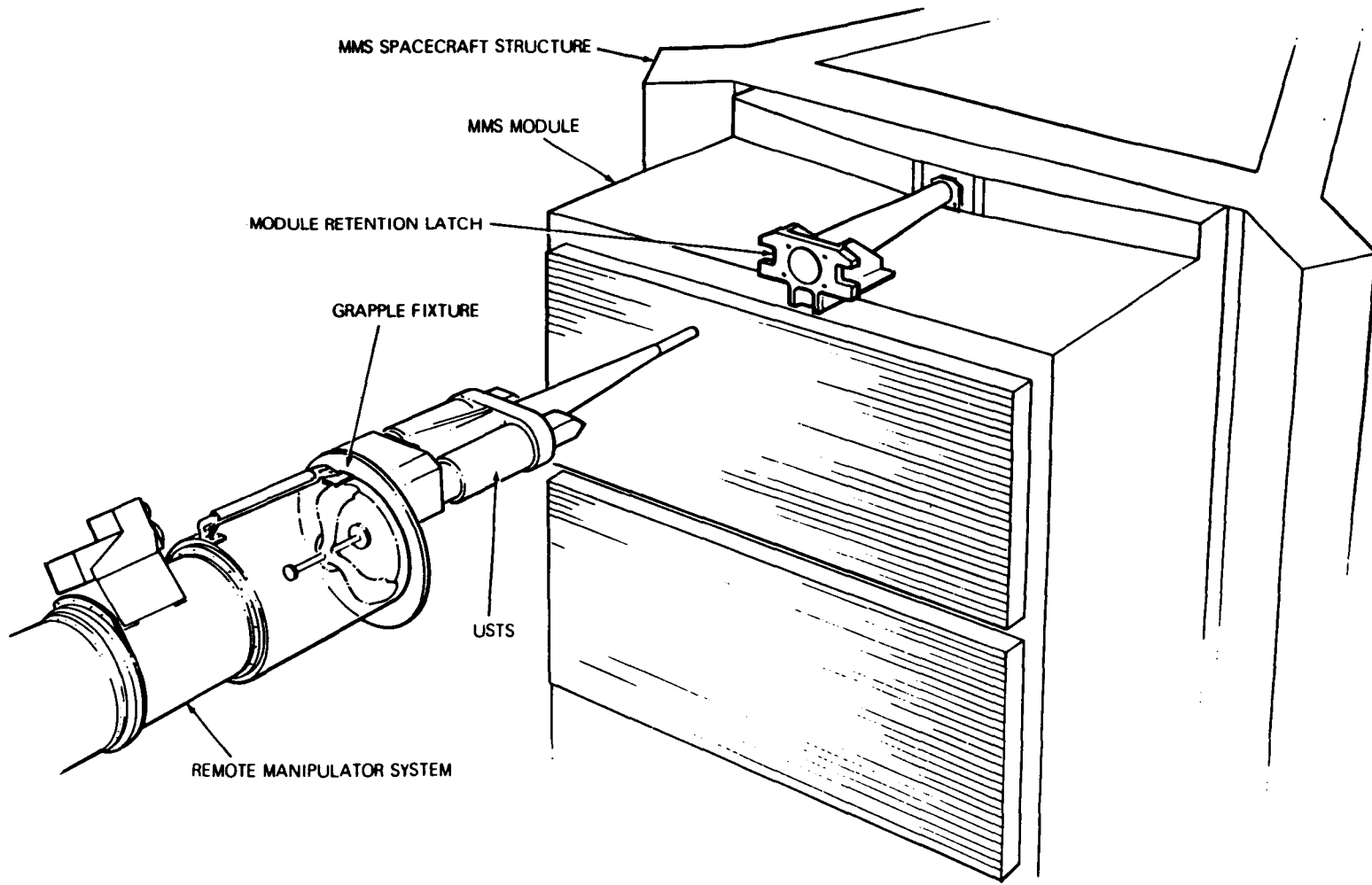

ORIGINAL PAGE IS
OF POOR QUALITY

7-G-320



THE ROLE OF SRMS IN SATELLITE SERVICING



CONCLUDING REMARKS

- SRMS IS THE BASELINE ORBITER PAYLOAD DEPLOYMENT AND RETRIEVAL SYSTEM.
- SRMS HAS A GROWTH POTENTIAL TO SUPPORT SERVICING TASKS AS REQUIREMENTS EVOLVE.
- SRMS GROWTH FOR SATELLITE SERVICING IS GENERALLY BY ADD-ON KIT (E.G. SPECIAL END EFFECTORS).

31

ORIGINAL PAGE IS
OF POOR QUALITY

32 1183 11178

MANNED MANEUVERING UNIT

32

Fran Bergonz
Martin Marietta

ORIGINAL PAGE
BLACK AND WHITE PHOTOGRAPH

MMU CAPABILITIES

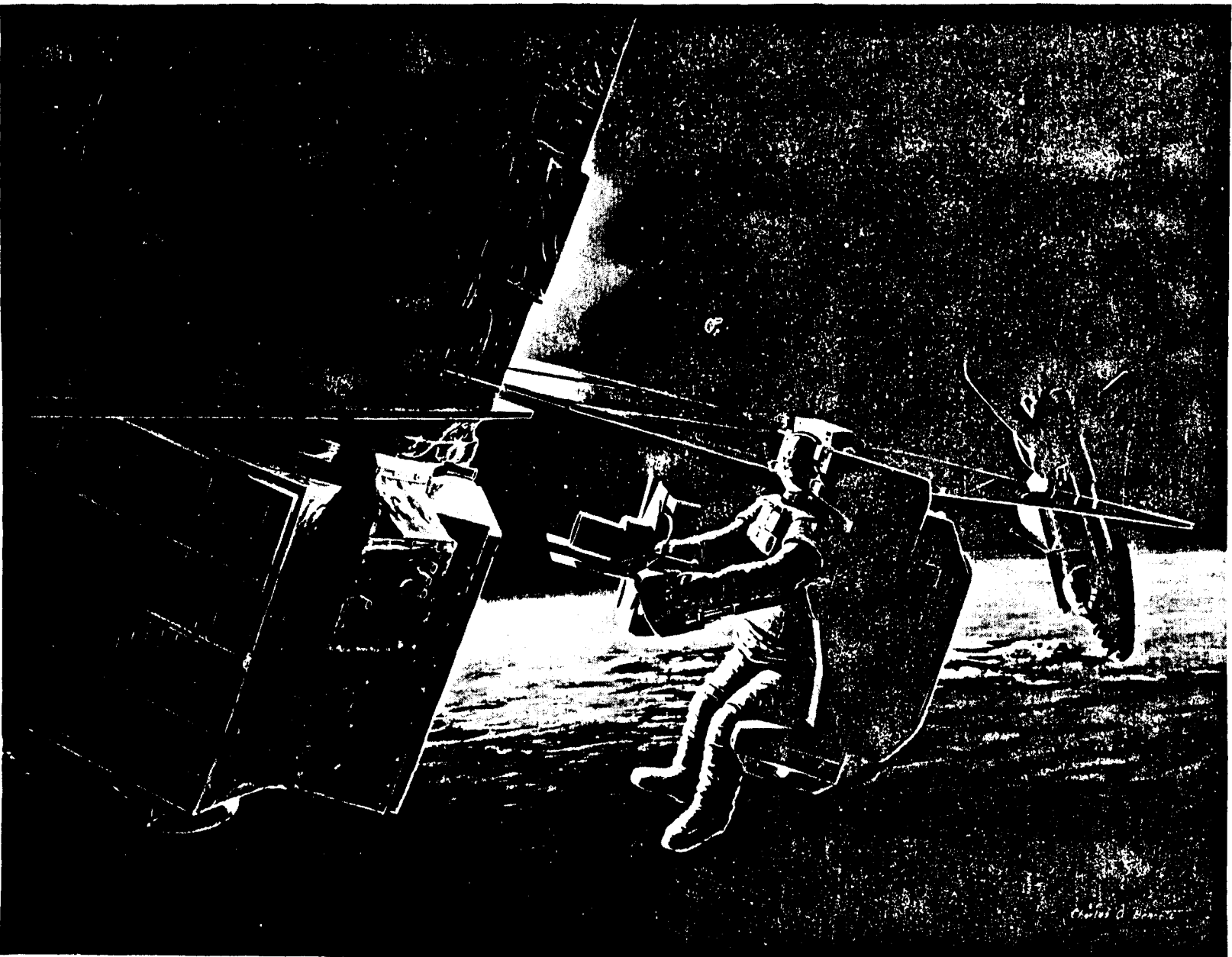

ORIGINAL PAGE IS
OF POOR QUALITY

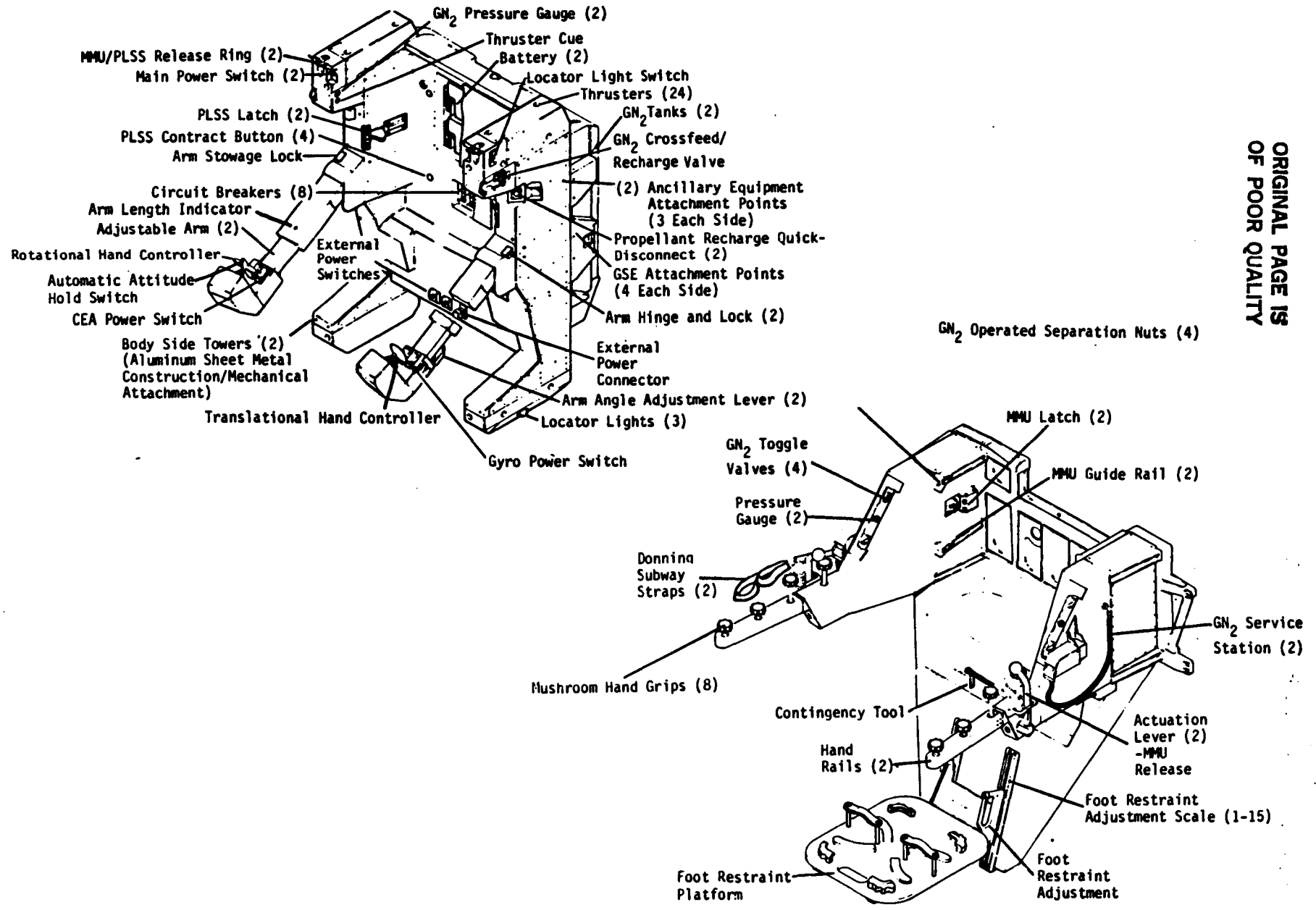

34

MMU/FSS INSTALLATION LOCATION

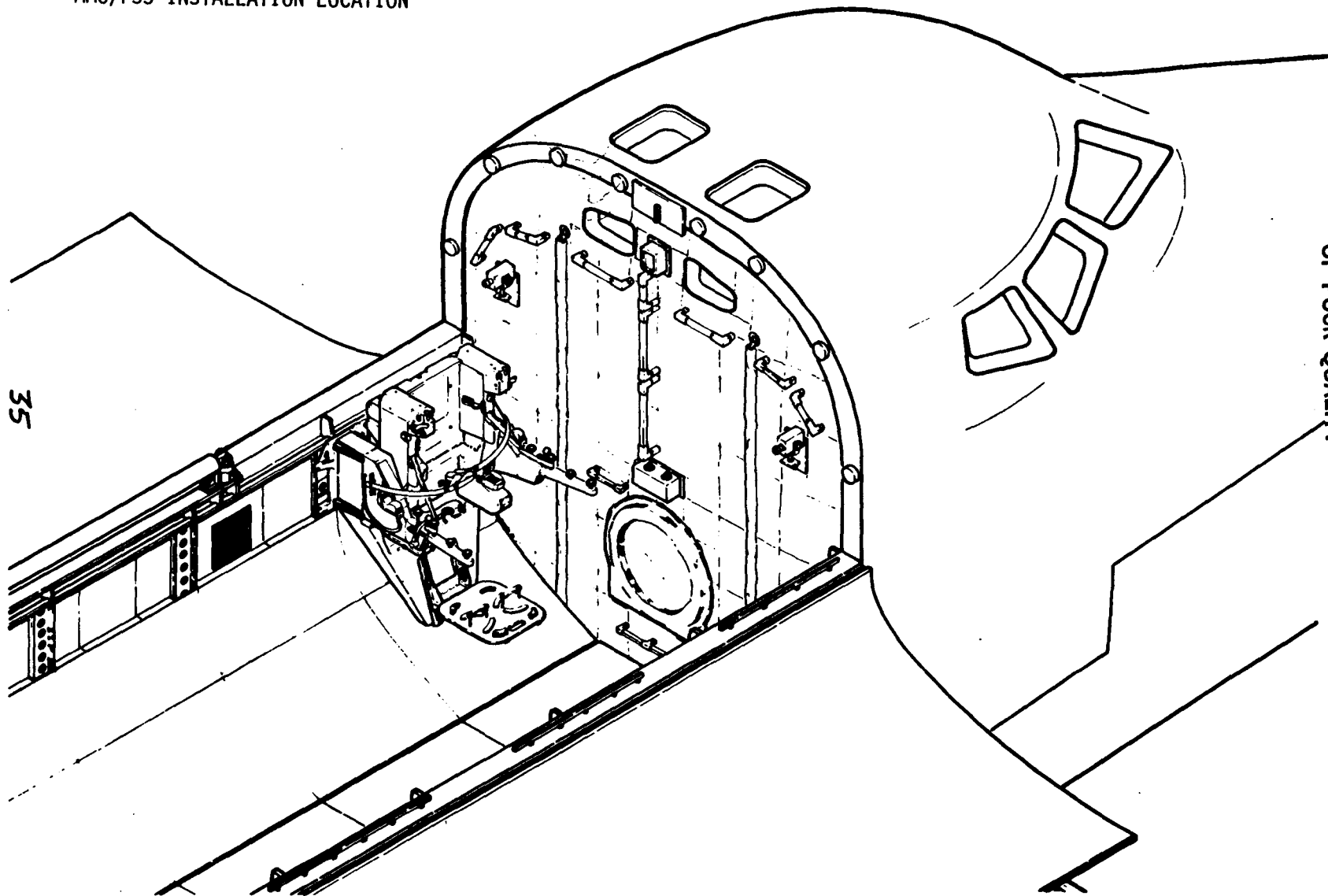

35

ORIGINAL PAGE IS
OF POOR QUALITY

MMU PROPELLANT USAGE

- TANKS CHARGED WITH 26.2 POUNDS GN₂ FOR LAUNCH.
- AVAILABLE IMPULSE = 1593 LB-SEC.
- V = 66 FPS AT SYSTEM WEIGHT OF 755 LBS.
- AN ON-ORBIT RECHARGE PROVIDES UP TO 22.4 LBS GN₂.
- 1593 LB-SEC IMPULSE = 234 SEC OF TRANSLATIONAL COMMANDS
(4 THRUSTERS FIRING)
OR 468 SEC OF ROTATIONAL COMMANDS
(2 THRUSTERS FIRING)
- ASSUMING 75% TRANSLATION, 25% ROTATION, A SINGLE CHARGE PROVIDES
267 SECONDS OF THRUST.
- FOR 300 MILLISECOND COMMANDS (SOS FLIGHT SIMULATIONS AVERAGE)
THERE ARE 890 SEPARATE COMMANDS PER CHARGE.

36

ORIGINAL PAGE IS
OF POOR QUALITY

MARTIN MARIETTA

NUMBER OF ROUNDTrips VERSUS VELOCITY AND DISTANCE

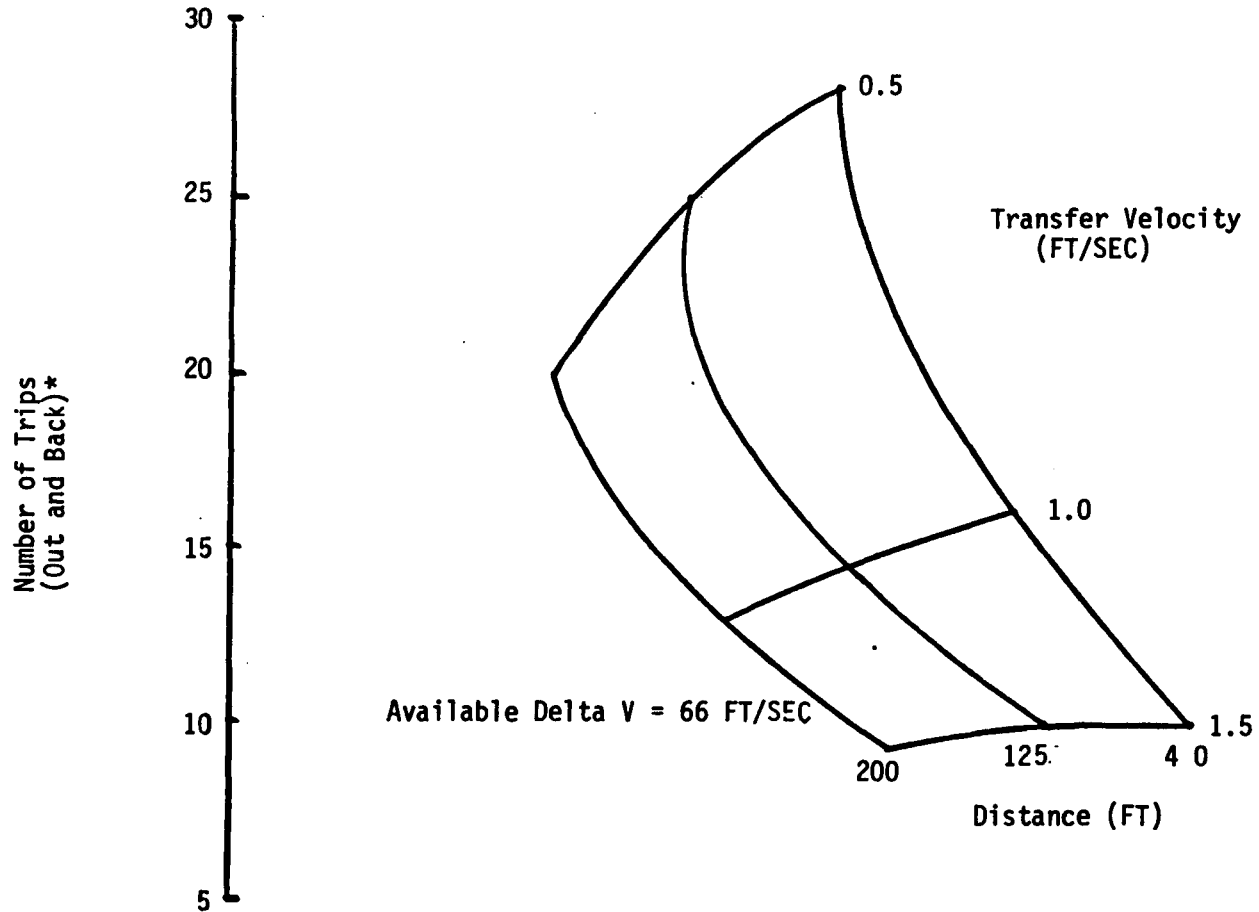

37

ORIGINAL PAGE IS
OF POOR QUALITY

* Assumes EVA crewmember does not depart from straightline path connecting the two endpoints by more than 3 feet.

MARTIN MARIETTA

MMU DELTA V CAPABILITIES WITH LARGE CARGOES

38

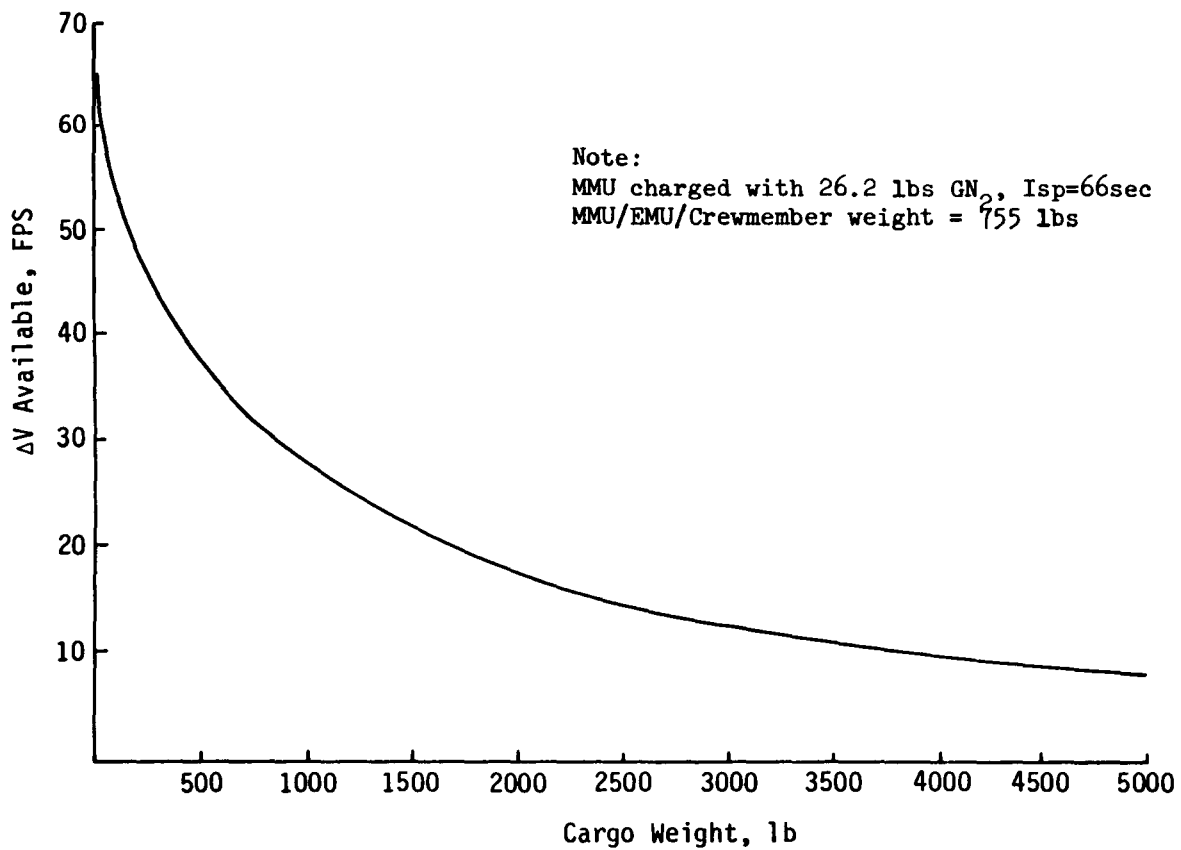

ORIGINAL PAGE IS
OF POOR QUALITY

MARTIN MARIETTA

ROTATIONAL MANEUVERS WITH LARGE CARGOES

RATE (DEG/S)	INERTIA (SLUG FT ²)	MOVEMENT ARM (FT)	REQUIRED IMPULSE (LB-SEC)	PERCENT FUEL USED
5	1,000	5	17.4	1.1
5	5,000	5	87.2	5.5
5	10,000	5	174.4	10.9
5	1,000	10	8.7	0.5
5	5,000	10	43.6	2.7
5	10,000	10	87.2	5.5
5	1,000	20	4.4	0.3
5	5,000	20	21.8	1.4
5	10,000	20	43.5	2.7
1	1,000	5	3.5	0.2
1	5,000	5	17.5	1.1
1	10,000	5	35.1	2.2
1	1,000	10	1.8	0.1
1	5,000	10	8.8	0.5
1	10,000	10	17.5	1.1
1	1,000	20	0.9	0.06
1	5,000	20	4.5	0.3
1	10,000	20	9.0	0.6

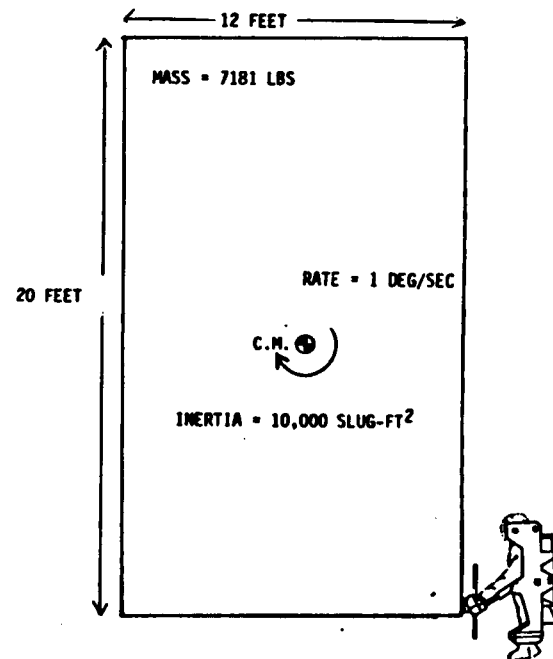

ORIGINAL PAGE IS
OF POOR QUALITY

39

$$\text{IMPULSE} = \frac{\text{RATE (RAD/S)} \times \text{INERTIA}}{\text{MOMENT ARM}}$$

A 7181 POUND CYLINDRICAL SATELLITE, DIAMETER 12 FEET, HEIGHT 20 FEET, ATTACHED TO THE MMU AS SHOWN WOULD RESULT IN A SYSTEM INERTIA OF 10,000 SLUG FT² IN THE MMU PITCH AXIS. THE IMPULSE REQUIRED TO INITIATE A 1 DEG/SEC ROTATION RATE IS 17.5 LB-SEC OR 1.1% OF THE USABLE PROPELLANT LOAD.

MARTIN MARIETTA

ANCILLARY EQUIPMENT ATTACHMENT INTERFACE

- BALL FITTINGS ON INSIDE END OF CONTROL ARMS.
- MATING PART IS "TRAILER HITCH" TYPE LATCH.
- ATTACHMENT MADE BY PULLING LATCH ASSEMBLIES OVER BALL FITTINGS.
- DISENGAGED BY SIMPLE HAND LEVERS, EACH SIDE.

SATELLITE ATTACHMENT DEVICE

- ATTACHES TO MMU AT CONTROL ARM BALL FITTINGS.
- HARD CONTACT WITH SPACECRAFT TRUNNION FITTING CAUSES SPRING LOADED PADS TO GRASP EXTERIOR OF FITTING WHILE SIMULTANEOUSLY SENDING THREADED INSERT INTO INTERIOR OF FITTING.
- CREWMEMBER TURNS RATCHET HANDLE TO EXPAND INSERT TO FIT SNUGLY AGAINST INSIDE OF FITTING.
- AFTER SPACECRAFT RATES HAVE BEEN NULLED, MMU IS DISENGAGED FROM TRUNNION, LEAVING RMS GRAPPLE FIXTURE.
- SHUTTLE RMS ATTACHES TO GRAPPLE FIXTURE FOR SPACECRAFT BERTHING IN THE CARGO BAY.

4)

MARTIN MARIETTA

SMALL PAYLOAD MANEUVERING SYSTEM (SPMS)

- o SMALL FREE FLIER BERTHED IN PAYLOAD BAY, CONTROLLED FROM AFT CREW STATION.
- o SUPPORTS SHUTTLE PROXIMITY PAYLOAD SERVICE OPERATIONS.
- o CAN BE LAUNCHED WITH PAYLOADS UP TO 800 POUNDS.
- o SYSTEM CHARACTERISTICS.
 - TV/TELEMETRY - MTV BASELINE
 - COLD GAS (GN2) PROPELLANT
 - ΔV - WITHOUT PAYLOAD, 340 FT/SEC
 - WITH 800 LB PAYLOAD, 140 FT/SEC
 - OPERATING RANGE - 10 MILES
 - CAN PROVIDE COMMAND, DATA, POWER, AND/OR PROPELLANT INTERFACES TO PAYLOAD
 - PROVIDES QUICK REACTION CAPABILITY FOR SMALL PAYLOADS

ORIGINAL PAGE IS
OF POOR QUALITY

42

MARTIN MARIETTA

SPMS APPLICATIONS

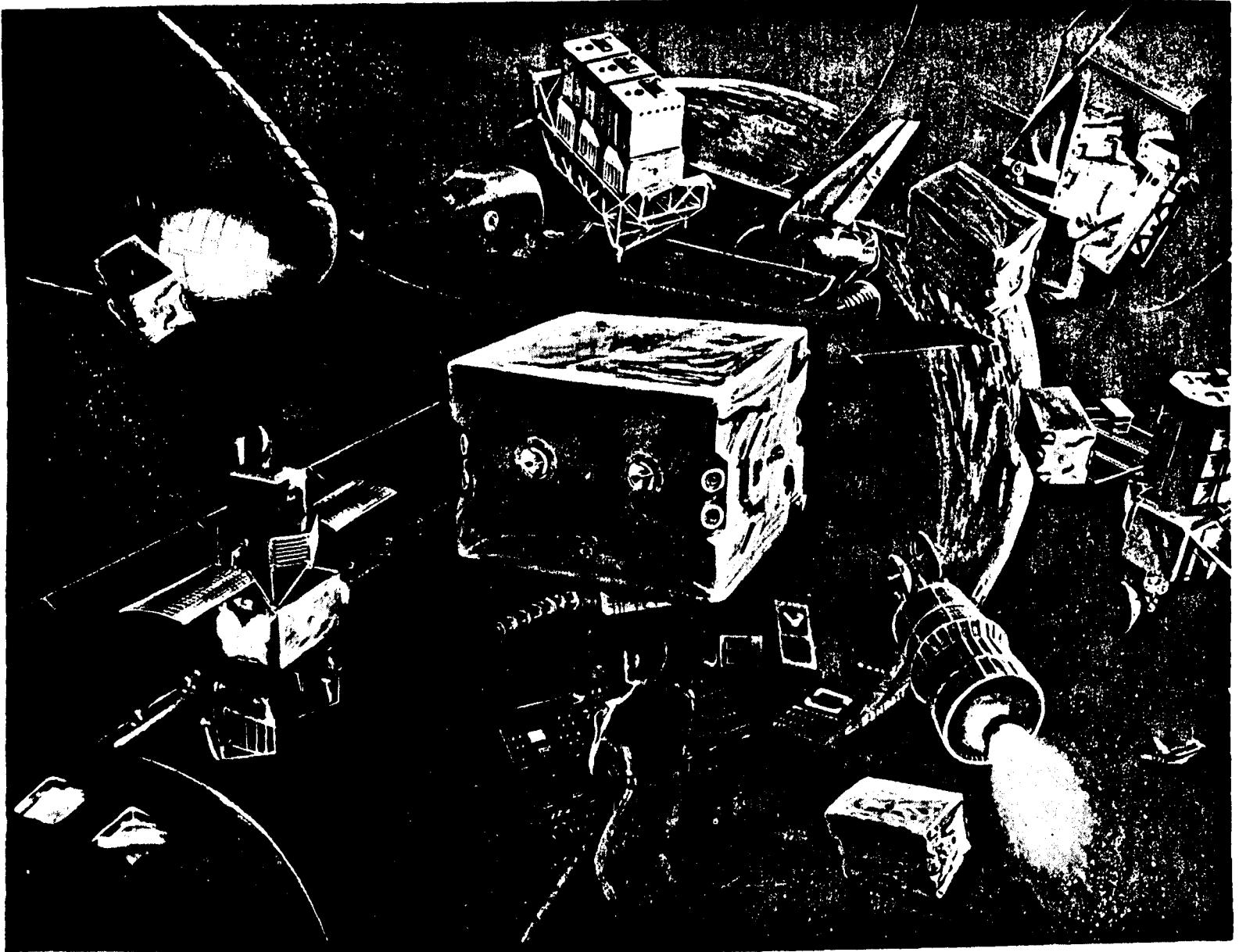

ORIGINAL PAGE
BLACK AND WHITE PHOTOGRAPH

111

N83 111 0

THE SHUTTLE EXTRAVEHICULAR MOBILITY UNIT (EMU)

PROVEN HARDWARE FOR SATELLITE SERVICING

Michael N. Rouen
NASA - Johnson Space Center

Kenneth R. King
Hamilton Standard

Presented To:

Satellite Services Workshop
NASA - Johnson Space Center
Houston, Texas

22 - 24 June 1982

Extravehicular Mobility Unit

ABSTRACT

A general technical description of the Extravehicular Mobility Unit (EMU) is given. The description provides a basis for understanding EMU mobility capabilities and the environments a payload is exposed to in the vicinity of an EMU.

Introduction

The Crew Systems Division (CSD) of NASA/JSC has responsibility for the Space Transportation System life support efforts. One such system, the Extravehicular Mobility Unit, is planned to play a major role in servicing satellites and other payloads. By correlating data from CSD on EMU capabilities, environmental interfaces and new programs with Flight Operations Directorate (FOD) data on timelines and crew training and also with Spacecraft Design Division (EW) data on equipment and payload structural interfaces, the NASA plans to establish a methodology for efficiently scheduling, and planning a satellite servicing mission.

The Extravehicular Mobility Unit (EMU) is the device which permits the Shuttle astronaut to use the most versatile tools known to man - the human hand and eyes - in the conduct of a wide range of Shuttle space operations - both planned and unanticipated.

To work in space, the crewperson must be mobile and be able to live comfortably in the vacuum environment. Environmental protection and mobility are provided by the Space Suit Assembly (SSA). Life support functions are provided by the Life Support Subsystem (LSS). These are the two main subsystems of the EMU. The purpose of this paper is to provide a technical description of the EMU and demonstrate that the EMU may be used as a safe, efficient EVA tool.

A description of the SSA hardware and resultant mobility will demonstrate extravehicular/intravehicular capabilities of the suited crewperson. These capabilities are described in detail in the paper titled "Crewman Suited IVA/EVA Capabilities" authored by Mr. Jim Jaxx and contained in the Servicing Operations Section of the Workshop Papers. A knowledge of the internal workings of the LSS will help in understanding the EMU mission profile and environments which a payload is exposed to when approached by an EVA crewperson. One purpose of this EMU description is to answer the "How does it work?" questions that are important to payload designers. It is expected that the information contained in this document will assist the Shuttle user community in planning for the use of EVA to effectively support payload and other Shuttle operations.

Space Suit Assembly

The primary function of the Space Suit Assembly (SSA) is to maintain the pressure required for safe operation in a vacuum environment while providing a high degree of mobility to accomplish a wide range of tasks. Other functions include:

- Protection from the extremes of temperature encountered in space
- Protection from radiation and micrometeoroid environments

These functions are provided by the SSA which is composed of some nine separable components which are connected together by quick disconnects. Following is a description of components and functions required of the SSA.

Pressure Retention

The pressure vessel is made up of the Helmet/Extravehicular Visor Assembly, (Helmet/EVVA), the Hard Upper Torso (HUT), the Lower Torso Assembly (LTA), and the Arms and Gloves (see Figure 1). These assemblies and components are all connected together by pressure sealing quick disconnects which allow the crew-person to don the LTA, then the HUT (which already has the arms attached) and then the Gloves and Helmet/EVVA.

The suit pressure is maintained with oxygen at 4.3 psia pressure. This pressure level is a compromise between several competing demands. An increased suit pressure has the benefits of reducing or eliminating the prebreathe time required to denitrogenate the body to preclude the bends and of giving ample margin between operating pressure and minimum emergency pressure. A decreased suit pressure has the benefits of reducing space suit operating forces, pressure loads, and structural bulk. For a given space suit design, lower pressure results in increased mobility.

The Helmet/EVVA (Figure 2) provides pressure retention by means of a bubble-shaped, one-piece polycarbonate shell which is attached to the metallic quick disconnect. The HUT (Figure 2) is a conformed fiberglass structure which provides not only pressure retention but the mounting base on which the LSS components are mounted. The LTA, Arms, and Gloves (Figure 2) are softgoods which provide pressure sealing by means of a heat sealed polyurethane coated nylon bladder. The bladder material is not designed to carry the structural loads. The longitudinal structural loads are generated in two ways: (1) pressure area loads and (2) man-induced loads. These longitudinal structural loads range from a low of 150 lbf at the outside of the boot to a high of 1400 lbf at the waist and are carried by a primary restraint which is made of sewn webbing for the LTA (Figure 3), arms, and gloves. To provide high reliability, a secondary restraint system is also provided which remains unloaded unless the primary restraint lines fail. The circumferential loads are carried by a layer of polyester cloth. This material completely encloses the bladder material and provides the structural support required. The restraint materials are selected to minimize stretch since they also determine the shape and size of the SSA under pressure.

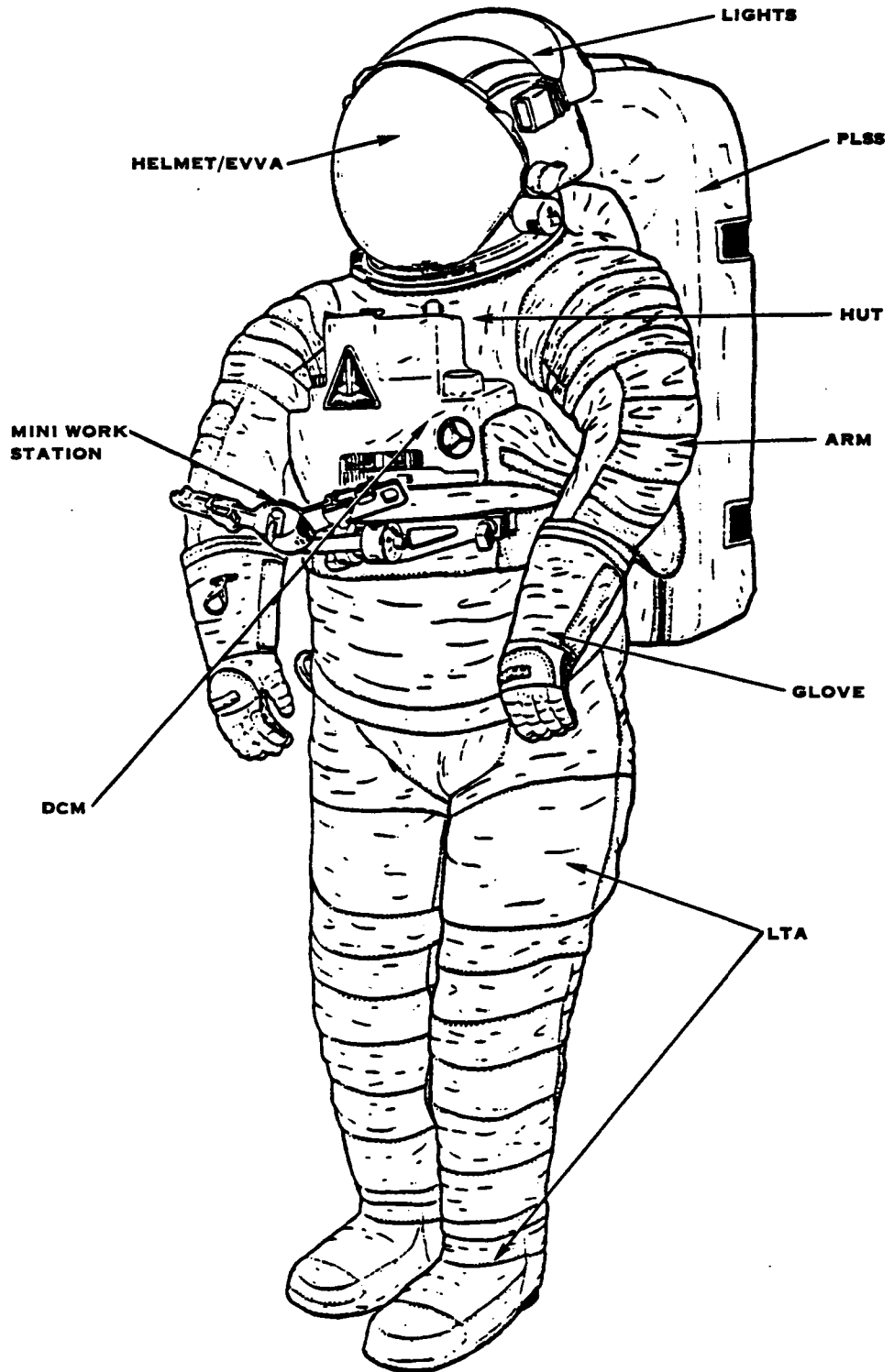

FIGURE 1.

Mobility

The essential challenge of SSA design is to maintain pressure integrity as described above while providing mobility. A feel for the magnitude of this challenge can be obtained by looking at what forces would be required to operate a SSA which contained no mobility elements at the body joints (see Table 1). The current Shuttle SSA specifications are also shown in the table for comparison of mobility joint performance. The torques and forces required to bend a suit element are generated because bending the joint causes an internal volume change. For example, the volume change associated with bending the knee joint 90° if it does not have a mobility element is 242 in³. The allowed volume change to stay within the 12 in lbf specification is 2.8 in³. From this it can be seen that the ideal joint mobility characteristic is one in which the volume stays constant as the joint is articulated, and ideally approaches capabilities by existing SSA joint designs.

Mobility elements are located at the shoulder, elbow, wrist, and fingers in the upper torso area (Figure 2). The lower torso includes mobility elements at the waist, hip, knee, and ankle (Figure 3). Except at the shoulder, where a rolling convolute is used and at the wrist and fingers where tucked fabric joints are used, the mobility elements of the Shuttle suit are flat pattern designs which are tailored to give a stable joint with minimum torque.

Another aspect of mobility is rotation. To allow rotation of the shoulder, arm, and hand, there are pressure sealing ball bearings (Figure 2). There is also a waist bearing (Figure 3) which allows upper torso twisting motions which are very effective in increasing the available reach envelope of the suited crewperson.

The best mobility elements and bearings are of little help, though, unless the bending or twisting axis corresponds with the respective axis of the crewperson's body. To assure this correspondence, the SSA must fit the crewperson well. The Apollo and Skylab programs used spacesuits which were custom procured for the crewman; this is not feasible for the Shuttle Program because of the expense associated to accommodate the larger number of astronauts and 15 year program lifetime. Consequently, the Shuttle SSA incorporates provisions for modular sizing. Table 2 lists the quantity of sizes of the various components. Vernier sizing of the arms and legs (Figure 3) is incorporated with a sizing insert system which assures that the elbow and knee mobility element bending axis corresponds with the bending axis of the crewperson's joints.

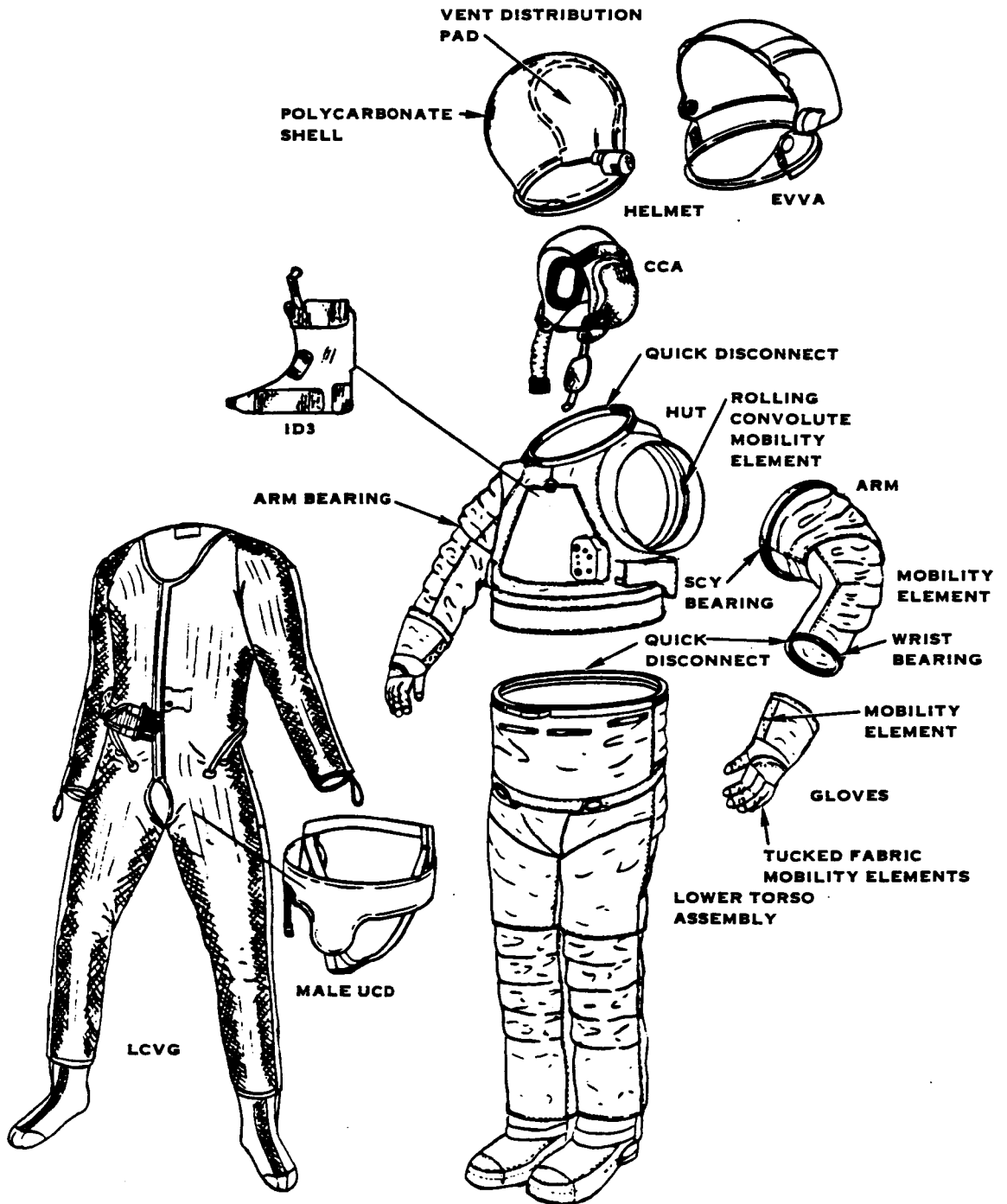

FIGURE 2.

TABLE 1
TORQUES & FORCES REQUIRED TO BEND A
4.3 PSID PRESSURIZED CYLINDER THROUGH 90°
(NO JOINT)

Cylinder Diameter		Joint Represented	Torque Required		Force Needed At End Of Cylinder		Shuttle SSA Torque Spec.	
cm	(Inches)		cm-dyne·10 ⁶	(in-lbf)	dynes·10 ⁸	(lbf)	cm-dyne·10 ⁶	(in-lbf)
2.54	(1)	Finger	9.04	(8)	.0134	(3)	---	---
10.16	(4)	Elbow	599	(530)	.201	(45)	13.6	(12)
12.70	(5)	Knee	1,180	(1,040)	.267	(60)	13.6	(12)
40.64	(16)	Waist	38,400	(34,000)	4.23	(950)	54.2	(48)

$$T = \frac{Pad^3}{46}$$

T = Torque, in-lbf
P = Suit pressure, psid
a = deflection angle, degrees
d = cylinder diameter, inches

TABLE 2
QUANTITY OF SIZES

COMPONENT	NUMBER OF SIZES
Hard Upper Torso	5
Waist	3
Lower Torso	4
Boots	2 (1)
Gloves	15
Liquid Cooling & Ventilation Garment	5
Communications Carrier Assembly	6
Arm	6

(1) Slipper-like inserts are provided to accomodate a wide range of foot sizes.

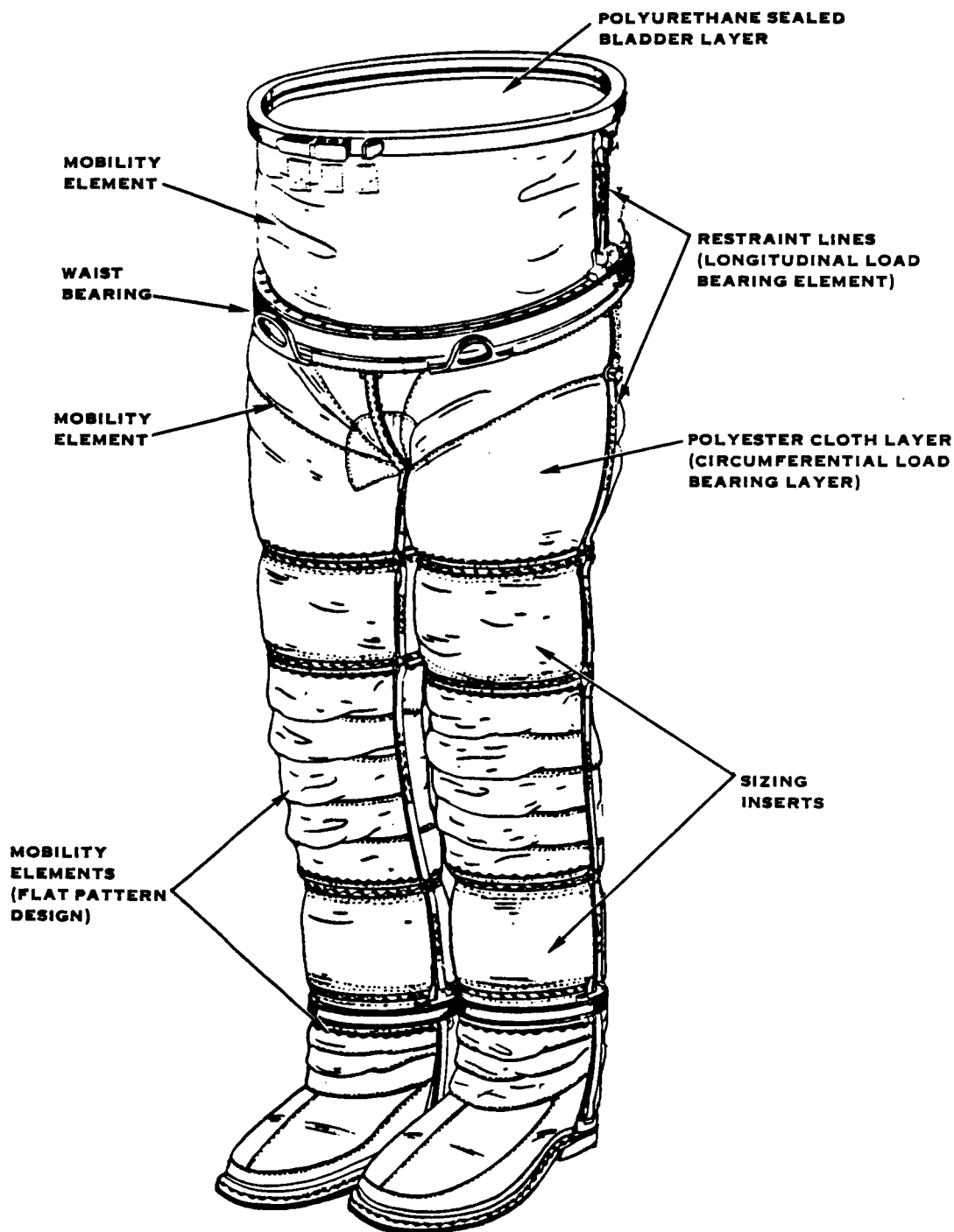

FIGURE 3.

Thermal & Micrometeoroid Protection

All elements of the EMU are covered with a thermal/micrometeoroid garment (TMG) which consists of 5 layers of reinforced aluminized mylar (Figure 4). This type of insulation is a function of operating environment. This insulation limits the EMU heat leaks into or out of the EMU to 330 Btu/hr, whether in full sun or deep space shadow. The outer layer is ortho fabric (expanded teflon yarn surface weave with a nomex/kevlar weave sublayer) and acts as an abrasion resistant layer. These layers provide effective solar radiation protection for the crewperson except for face and eyes. The Extravehicular Visor Assembly (EVVA) provides movable shades to allow eye and face protection from solar glare (Figure 2).

Ventilation Gas Distribution

To assure adequate removal of exhaled gases from the crewpersons oral/nasal area, the LSS provides a minimum rate of 6 ft³/min of ventilation flow. This fresh incoming gas is directed over and around the crewpersons head by the helmet vent pad (Figure 2). The flow around the crewperson's head directs exhaled gasses to the neck area, where the flow goes between the suit inner layer and the crewperson providing the additional benefit of some cooling and removal of sweat. The flow goes to the hands and feet where it is picked up by a ventilation duct, which is part of the liquid cooling/vent garment (LCVG) (Figure 5). The flow is gathered together in a manifold and returned to the Life Support System.

Metabolic Heat Removal

Although this gas flow distribution does provide the crewperson with some cooling - the majority of the cooling is provided by a liquid transport loop which is also part of the LCVG. This loop consists of four parallel paths of small plastic tubing sewn into a full body garment which gently presses the tubes next to the crewpersons skin. As cool water flows through the tubes, it is warmed by the crewperson's metabolic heat. This warmed water is returned to the LSS where it is cooled and returned to repeat the process.

Communications Interface

To allow a redundant communications interface, the crewperson wears a cap (Figure 2) which contains two microphones and two earphones. This unit is called the Communications Carrier Assembly (CCA) and it connects electrically via the HUT to the radio located in the Primary Life Support Subsystem (PLSS) by way of an electrical cable.

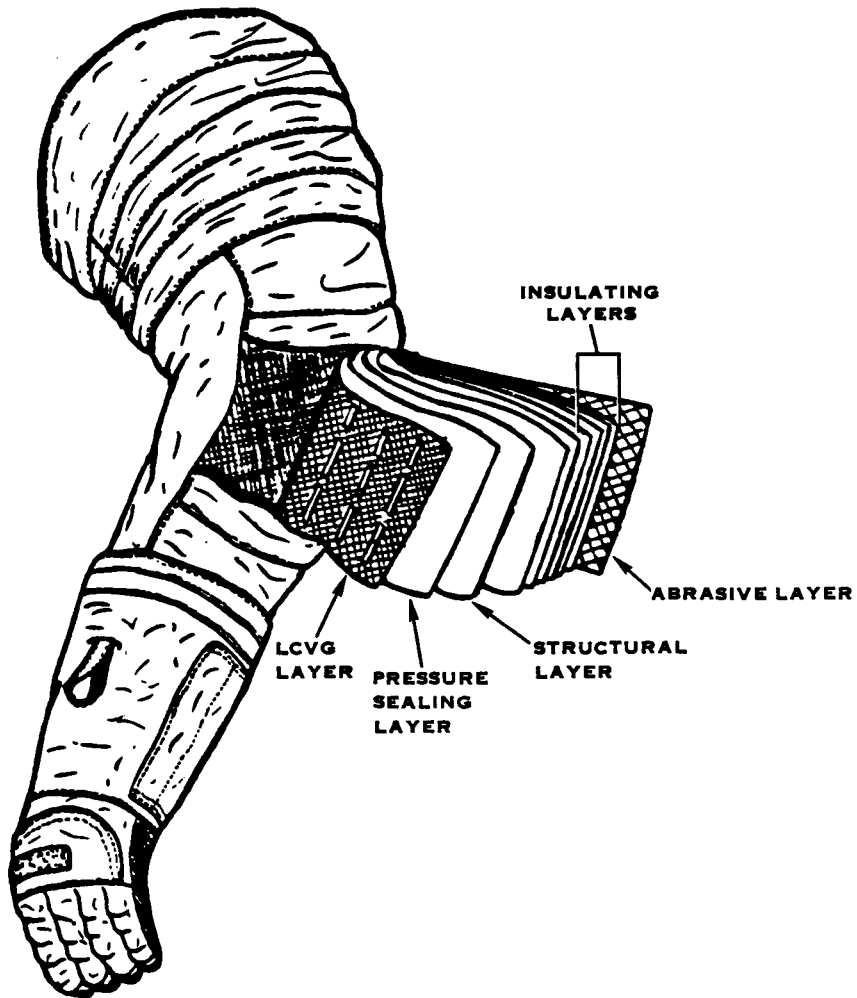

FIGURE 4.

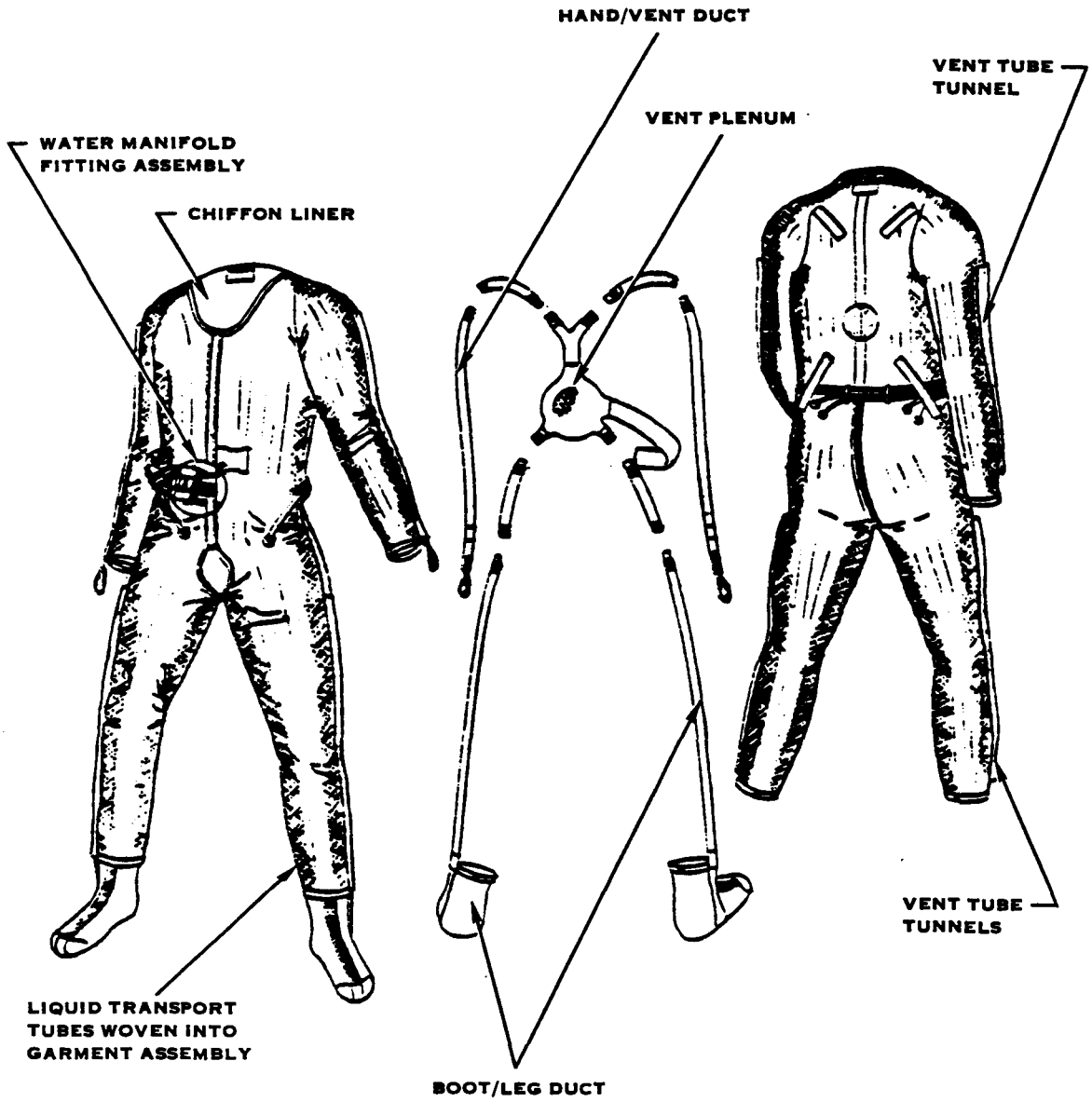

FIGURE 5. LIQUID COOLING VENT GARMENT (LCVG)

Food & Drink

The crewperson may take a drink from the Insuit Drink Bag which is a urethane film bag RF heat sealed together in the shape of the volume available in the front of the HUT (Figure 6). The bag contains a valve which is activated by a sucking motion so the crewperson obtains a drink as if he were using a straw. The valve precludes spillage caused by pressing on the bag. The bag is attached by velcro into the front of the HUT so the drink tube is easily available. Additionally, a food stick is located between the IDB and the HUT. The food stick is in a paper sheath which allows the crewperson to grip it with his teeth and pull it up and take a bite.

Waste Control

Liquid waste is collected in a urethane coated nylon bag which is worn by the crewman under the LCVG (Figure 2). Females wear a disposable containment device which collects liquid waste in a super absorbent material.

Hopefully this gives you an idea of what it means to get dressed to go to work in space. To maintain life in the vacuum environment of space is the job of the LSS which will be described next.

LIFE SUPPORT SUBSYSTEM

The Life Support Subsystem (LSS) supplies a pressurized flow of breathable ventilation gas to the helmet inlet and removes the metabolic heat from the liquid cooling loop of the LCVG. Functionally, the LSS is very simple. It consists of two separate closed flow loops which are interconnected in order to maintain fluid phase separation. The two main loops are the ventilation loop and the liquid cooling loop. Both loops have make up supplies in order to maintain their operating pressures at the prescribed levels (Figure 7).

Ventilation Loop

The ventilation loop receives warm, moist oxygen and exhalation products (mostly CO_2) from the SSA and directs it to the Contaminant Control Cartridge (CCC) (Figure 8). This gas is filtered by a layer of nomex felt and directed into a bed of Lithium Hydroxide. The carbon dioxide reacts with the Lithium Hydroxide (LiOH) to form Lithium carbonate. This process also adds heat and moisture to the flowing gas stream. Activated charcoal follows the LiOH bed and removes trace contaminants and odors. Finally, the gas passes through an exit nomex felt filter which precludes the migration of LiOH particles.

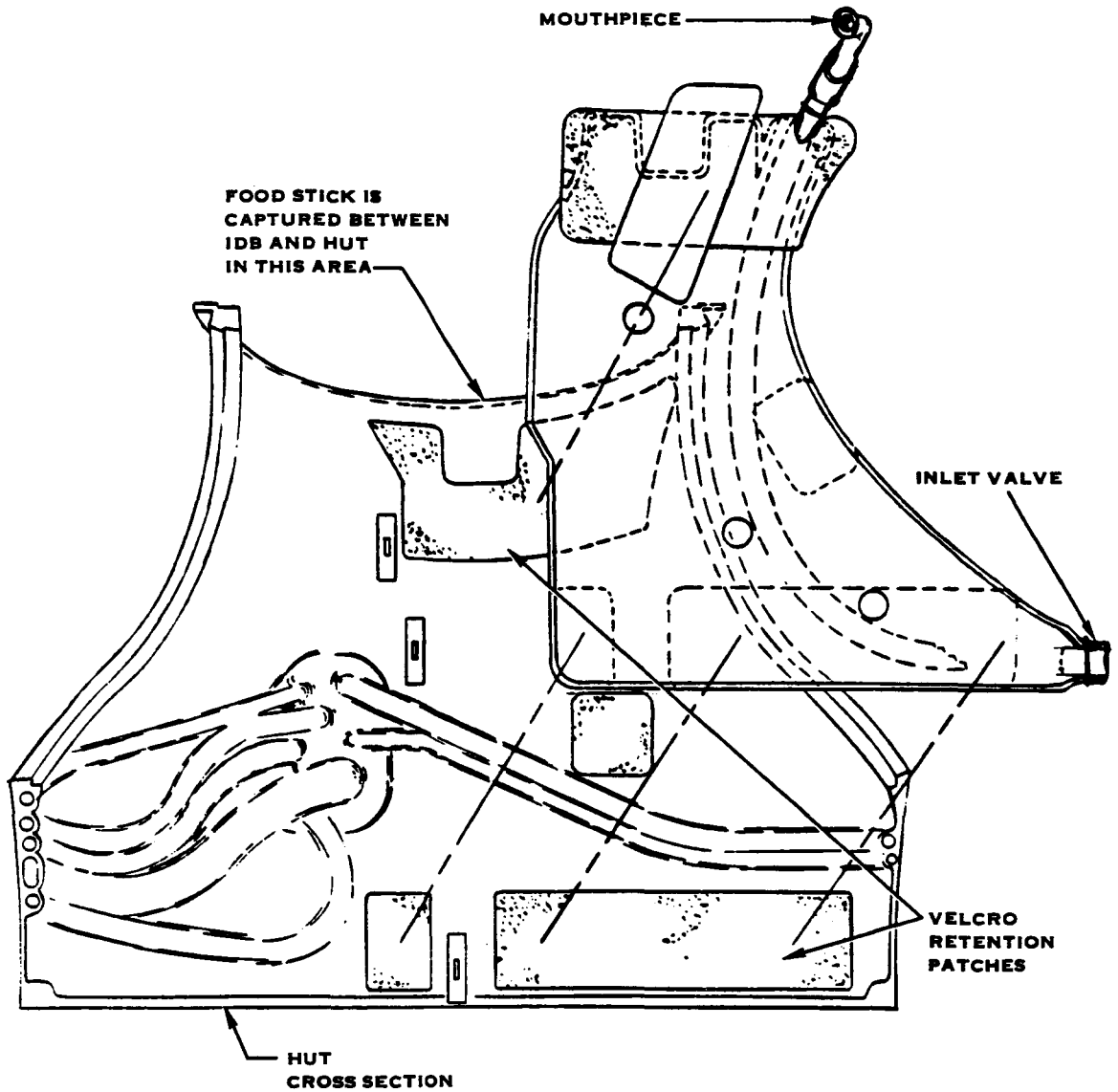

FIGURE 6. INSUIT DRINK BAG



UNITED
TECHNOLOGIES
HAMILTON
STANDARD

ORIGINAL PAGE IS
OF POOR QUALITY

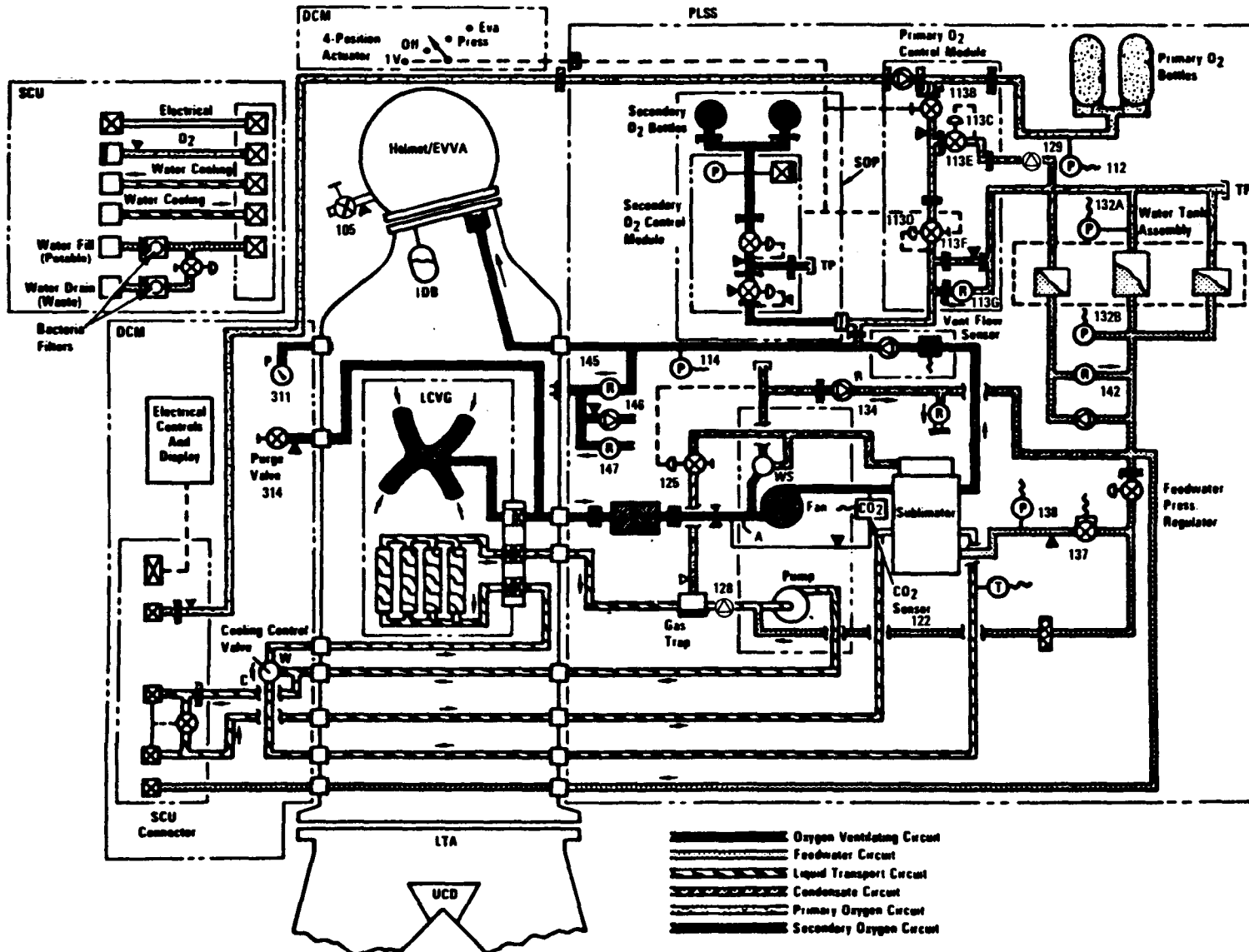

FIGURE 7 SPACE SHUTTLE EXTRAVEHICULAR MOBILITY UNIT SCHEMATIC

58

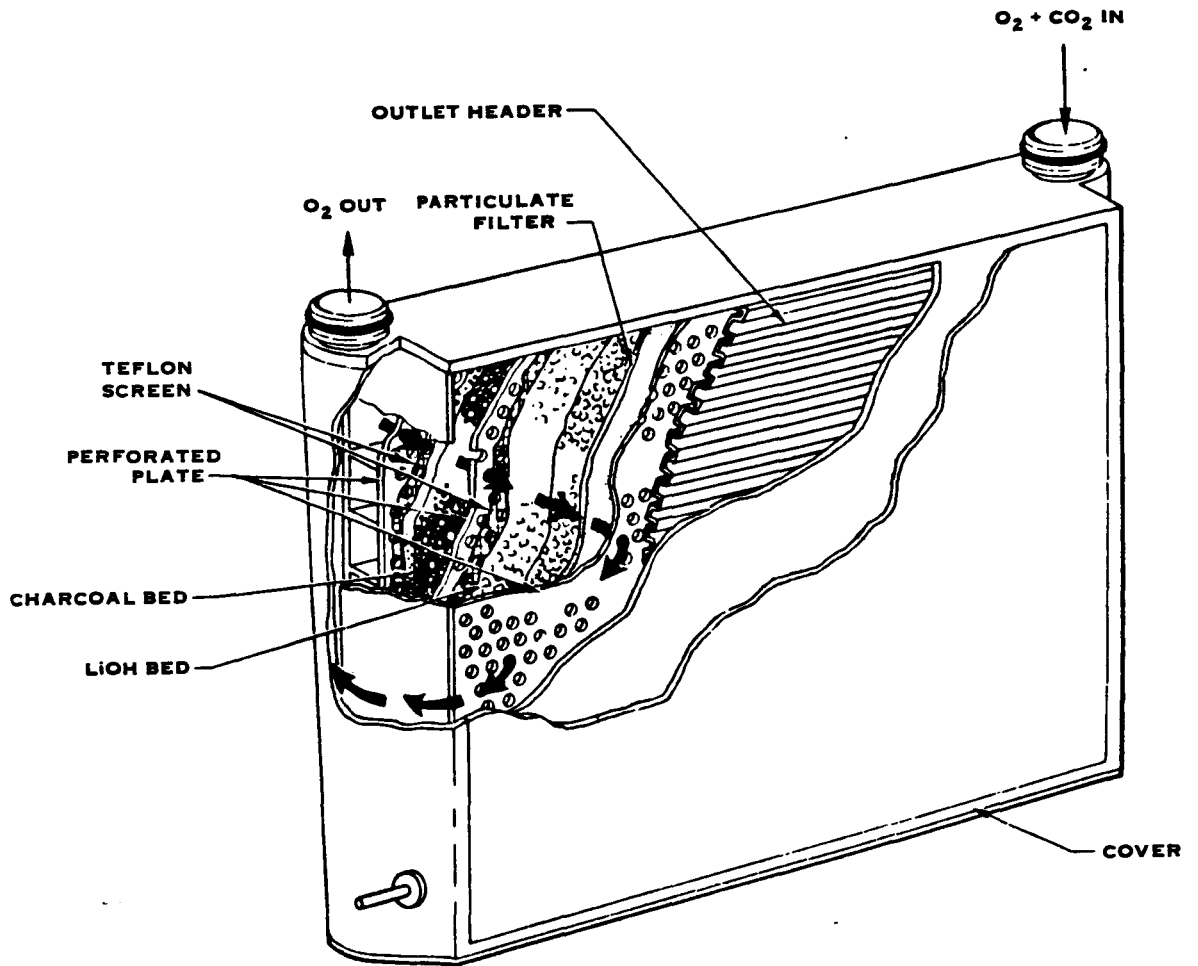

FIGURE 8. CONTAMINANT CONTROL CARTRIDGE

The ventilation gas then flows from the CCC into the fan (Figure 9) which maintains the flow velocity. The fan provides a minimum of 3 in of H₂O pressure rise. The fan is driven by a Hall sensor commutated DC motor at 19,000 rpm. The motor draws 2.3 amps at 16.3 volts. The fan directs the flow into the sublimator. The sublimator is the heat sink for the entire EMU. In the sublimator, the ventilation gas is cooled and the moisture it contains is condensed. The outlet dry bulb and dewpoint of the gas leaving the sublimator is about 55°F.

The condensed moisture is removed from the sublimator ventilation passages through a series of holes located at the end of the cooling fins. This is called a slurper (Figure 10). The driving potential for this flow is the delta pressure across the fan because the slurper header is connected to the fan inlet. This allows a small percentage of the gas flow to be used to carry the condensed moisture to the water separator (Figure 8). At the water separator, the mixture of gas and water is forced to impinge on a rotating drum. The drum is mounted to the fan shaft and receives its driving power from the same motor as the fan. The drum is shaped so that the rotation causes the water to flow into a trough where it (by now rotating at the same speed as the drum) impinges on a stationary pitot tube. This arrangement pumps the water pressure up to the 15 psi required to flow past the back flow check valve (item 134, Figure 7) and into the water reservoir. Thus the condensate removal process is a two-stage phase separation process which begins in the sublimator and is completed at the water separator, where the water is pumped to the storage tank and the gas used to carry the water from the sublimator is returned to the ventilation loop.

After the ventilation flow leaves the sublimator it goes through a ventilation flow sensor (which also acts as a backflow check valve), and past the makeup supply inlet. A differential pressure sensor (Item 114, Figure 7) and a CO₂ sensor (Item 122, Figure 7) measure suit to ambient differential pressure and the partial pressure of CO₂ just prior to the ventilation flow reentering the SSA at the helmet inlet. A mechanical gage backup to the pressure transducer (Item 311, Figure 7) is placed on the display panel in front of the crewperson.

The makeup supply of the ventilation loop comes from the primary O₂ bottles which hold 1.2 lbm usable oxygen at 850 psi for the 7-hour EVA mission. This oxygen flows from the bottles into the primary oxygen control module which contains a flow limiting orifice (Item 113B, Figure 7), a shutoff valve (Item 113C, Figure 7) and a single stage demand regulator (Item 113D, Figure 7). This regulator maintains the ventilation loop (including the SSA) at a pressure of 4.3 psi above ambient pressure. A pressure transducer, (Item 112, Figure 7) is used to keep track of remaining oxygen.

**ORIGINAL PAGE IS
OF POOR QUALITY**

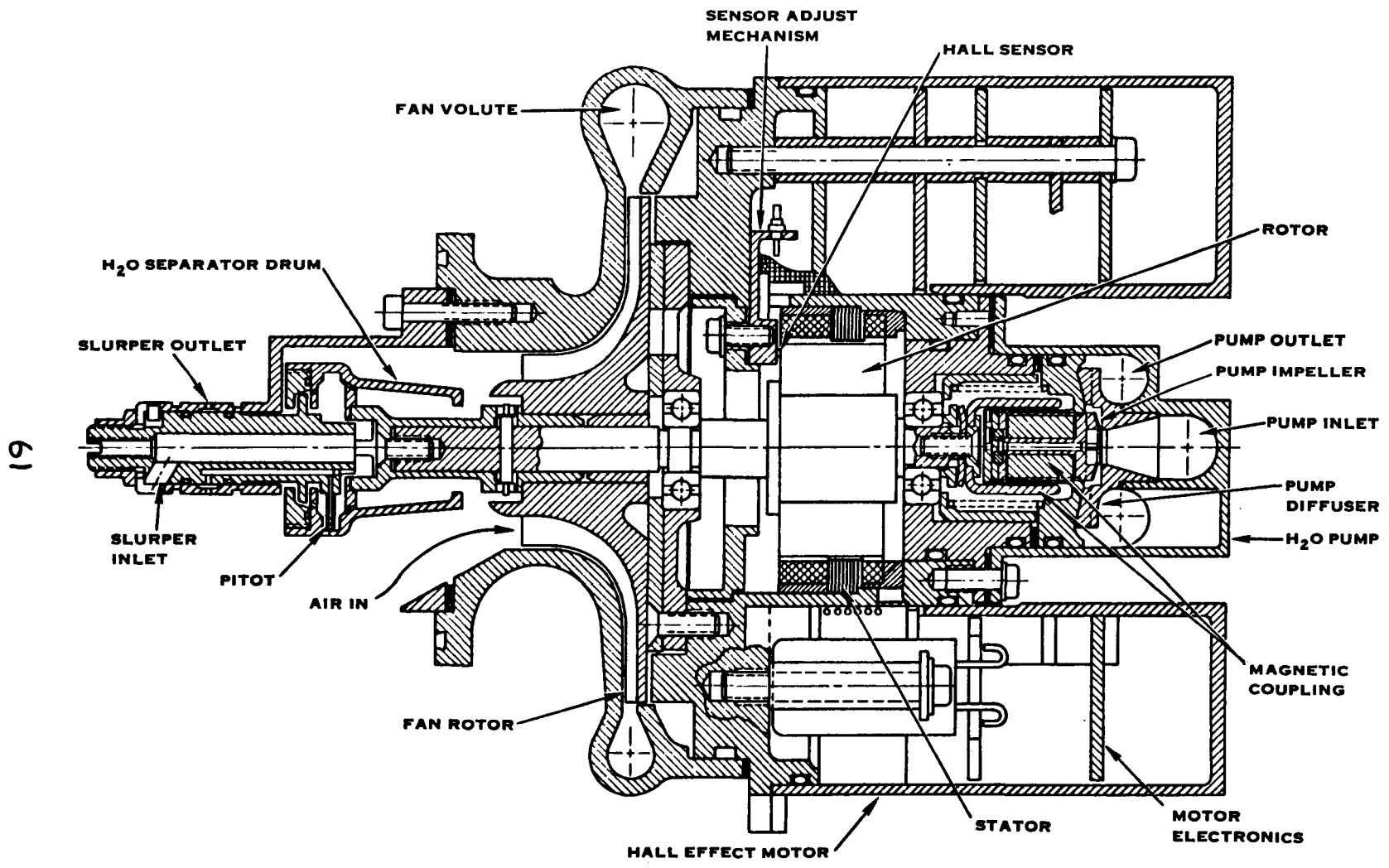

FIGURE 9. FAN, MOTOR, WATER SEPARATOR AND PUMP ASSEMBLY

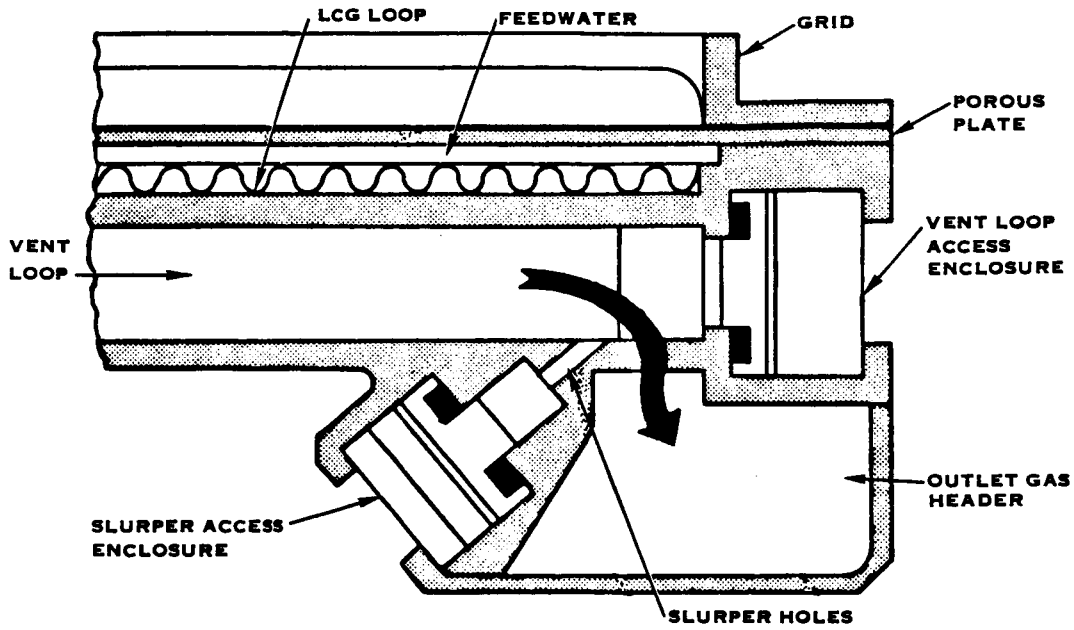

FIGURE 10. SLURPER CONFIGURATION

Liquid Cooling Loop

The liquid cooling loop receives warm water from the LCVG and directs it into a gas trap to remove any gas bubbles. The gas trap separates gas from the liquid cooling loop by means of a hydrophilic (water loving) screen. The screen is a fine mesh and since it is hydrophilic requires more pressure than is available for gas bubbles to go pass but very little pressure drop for water to go through it. The collected gas is continuously bled off through an orifice which controls the flow rate of water to be carried out of the gas trap when no gas is present. The mixture of gas and water then goes past an isolation valve Item 125, Figure 7 which is used to isolate the liquid cooling loop from the ventilation loop when the water separator is not open and flows into the water separator for the final stage of phase separation.

Returning from this subloop to the main liquid cooling loop, the water flow goes from the gas trap through a back flow check valve (Item 128, Figure 7), past the makeup inlet and into the pump (Figure 9). The pump is a centrifugal type (Barske to be specific) which is connected to the fan motor shaft by a magnetic coupling. The pump operates at fan speed (19,000 rpm) and flows 240 lbm/hr of water at a pressure rise of 4.8 psi. From the pump, the flow goes toward the cooling control valve. Along the way, the flow is split into two parallel paths. Part of the flow goes to the sublimator to be cooled and the remainder continues on to the cooling control valve. The continuing flow has been warmed by the crewman and so constitutes a warm water input to the cooling control valve. The part that has gone to the sublimator constitutes a cold water input. These two inputs are mixed in the cooling control valve to obtain a comfortable temperature and returned to the LCVG to remove the crewpersons metabolic heat. The cooling control valve is manually operated by the crewperson.

The makeup water which is used to maintain liquid cooling loop pressure comes from the water tank assembly. The water tank assembly consists of three tanks, two of which are connected together. The third tank is connected to the others through a relief valve (Item 142, Figure 7) which assures the third tank is the last one to be used. To drive the water out of the tanks, a soft neoprene rubber bladder is pressurized with oxygen from the primary oxygen bottles through a 15 psid demand regulator (Item 113F, Figure 7). This pressurant gas is supplied through a back flow check valve (Item 129, Figure 7) to the tanks. But, since the flow rate of pressurant needed is very small, the regulator would tend to cycle from closed to open and back again causing unwanted pressure variations. To keep this from happening, a constant demand is placed on the regulator through an orifice (Item 113F, Figure 7). To preclude water tank overpressurization in the event of a failed open regulator, a relief valve (Item 113G) has been included. There is also a pressure transducer (Item 132A, Figure 7) to monitor pressurant gas pressure. A similar transducer (Item 132B, Figure 7) is used to monitor the pressure of the water in the tanks. When these pressures are different by the 4 psid setting of the water tank isolation relief valve (Item 142, Figure 7) the crewperson is given a warning that there is only 1/2 hour of water supply left.

The makeup water supply comes to the liquid cooling loop from the water tanks and is also pressurized to 15 psid. Water leaves the liquid cooling loop at the gas trap to carry gas to the water separator. But after the water separator has completed the phase separation process, it returns the water to the water tanks. So, on an average basis, the liquid cooling loop is not a consumer of water and the water tanks acts only as an accumulator to maintain the pressure in the liquid cooling loop at a constant value. This completes the description of the Liquid Cooling Loop along with its makeup water supply. The interconnection between the ventilation loop and the liquid cooling loop has been described in order to define the fluid interfaces. Left undescribed in this section is the water consuming device, the water sublimator, and its associated hardware.

Feedwater Loop

The sublimator is supplied from the water tanks through a regulator which regulates the pressure to 2.9 psid. The flow then goes past a shutoff valve (Item 137, Figure 7) and a pressure transducer (Item 138, Figure 7) to the sublimator (Figure 11). The sublimator is a stack up of heat exchangers where the ventilation loop is cooled by the liquid cooling loop and the liquid cooling loop is cooled by the sublimation process which works as follows. Water enters from the feedwater supply and flows down the feedwater distribution channel. From there it spreads out under the porous plate and turns to go through the plate out to the vacuum which is on the outlet of the plate. But as the water pressure drops below the triple point pressure the water freezes to an ice layer in the plate. Heat is added to this ice from the flow loops and it sublimates away (i.e. goes from the solid to gas phase without again becoming liquid) into the vacuum, carrying with it the heat. If the ice layer is sublimated away completely, the feedwater again starts up toward the vacuum and is frozen forming a new ice layer. In this manner, the sublimator is a self-regulating, demand heat rejection device with a near constant heat sink temperature of about 32°F. The flow rate of steam to the vacuum is dependant on metabolic rate, equipment heat load, and heat leak into the suit. For the Shuttle LSS with a 330 Btu/hr heat leak (maximum) the steam output rate is

$$W = (M/1027) + 0.75$$

where W = water use rate lbm/hr
M = metabolic rate Btu/hr
(300 - 2,000 Btu/hr range with
1,000 Btu/hr average over 7 hours)

This completes the functional description of the Life Support System for normal operations.

The rest of the items seen on the schematic (Figure 7) are associated with the caution and warning system or are there to handle either emergency situations or to accomplish recharge between EVA's. For recharge, the service and cooling umbilical (SCU) connects the EMU to the vehicle from which water and oxygen are received to refill the respective tanks. Power is also received to recharge the silver-zinc battery. The CCC is removed and replaced with a fresh cartridge.

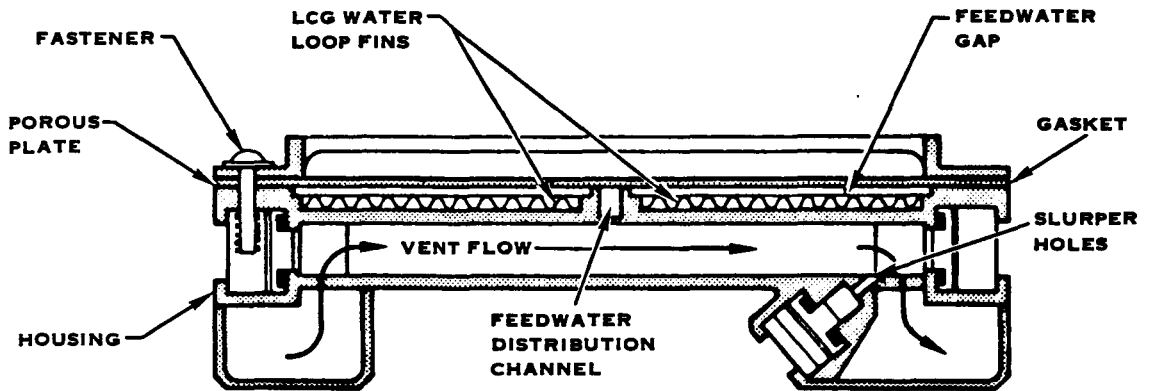

SECTION A-A

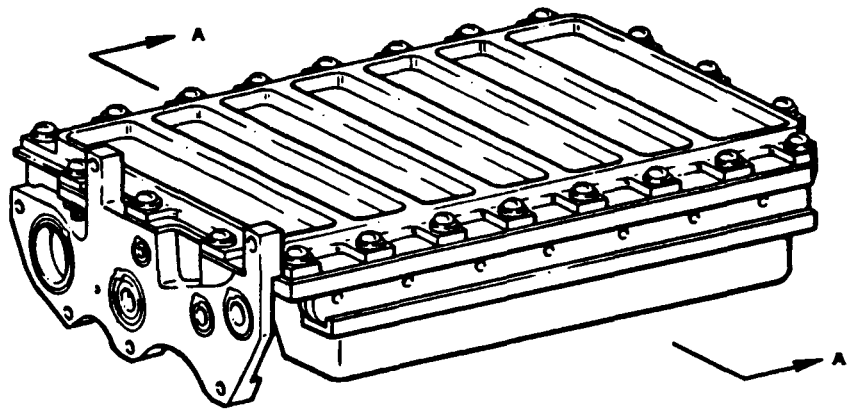

FIGURE 11. SUBLIMATOR

The warning system takes inputs from all of the instrumentation shown and provides the crewperson warnings when an expendable is within 1/2 hour of being expended and also indicates any malfunction. Displays are located on the Display and Control Module (DCM). The DCM also contains all of the controls necessary to operate the LSS. Included are relief valves (Items 134, 145, 146 and 147) to preclude any overpressure situations from damaging any of the LSS hardware as well.

In the event of primary life support subsystem (PLSS) malfunction the secondary oxygen pack (SOP) provides a 1/2 hr supply of oxygen which can be directed over the crewpersons face and exhausted to space through either the DCM located purge valve (Item 314, Figure 7) or the redundant helmet located purge valve (Item 105, Figure 7). This flow provides some cooling and carbon dioxide washout as well as suit pressurization, thereby allowing the crewperson to make an emergency return to the airlock.

Payload Interface⁽¹⁾

Now that the reader is well on his way to being an EMU engineer, its time to turn our attention to alterations of the free space environment generated by the EMU. These alterations fall into two categories: (1) the nominal alterations and (2) those associated with EMU contingency operations. The latter are normally limited to 1/2 hour duration and the larger frustration associated with that situation will probably be loss of EVA capability.

The sources of environment altering products for EMU are:

- 1) Water vapor from the heat rejection system
- 2) EMU leakage which includes water vapor, gases (i.e., O₂, CO₂) and trace organics.
- 3) Particles from EMU surfaces. (0.5 to 500 micron dust, lint, and metal)

The first of these was discussed earlier and for a nominal metabolic rate of 1000 Btu/hr which results in a steam production rate of 1.68 lbm/hr. Water vapor from leakage is estimated to be 5.4×10^{-4} lbm/hr. The rates for gases and organics are estimated to be 0.016 lbm/hr and 9.5×10^{-6} lbm/hr respectively.

Particles

The amount of particle disposition is unknown but the EMU particle generation surface area is 1/500 of the Shuttle so the EMU will not alter the environment when near the Shuttle vehicle.

(1) The authors are indebted to Mr. S. Martin NASA/JSC for use of the payload interface material.

TABLE III
LOCAL CONTAMINATION BY PARTICLES

<u>Particle Size</u>	<u>Altitude</u>	<u>Estimated Time To Clear 40 ft Area</u>
5 micron	100 nm	1.8 sec.
100 micron	100 nm	7.8 sec.
5 micron	300 nm	50 sec.
100 micron	300 nm	181 sec.

TABLE IV
 SCATTERING, ABSORPTION AND EMISSION
 BY PARTICLES WITHIN ORBITER WAKE

<u>Particle Size</u>	<u>Altitude</u>	<u>Estimated Time To Sweep over Horizon</u>
5 micron	100 nm	15 min.
100 micron	100 nm	66 min.
5 micron	300 nm	9.4 hrs.
100 micron	300 nm	34.4 hrs.

Water Vapor

Water vapor freezing on cold surfaces obscures sensors. This type of contamination is dependent on sensor surface temperature, distance from water source to sensor, and water flow rate. Water contamination can occur on a surface which is below 150°K and occurs within fractions of a second. Therefore, any payload with optical systems colder than 150°K must be shielded or suffer the effects of permanent water contamination (again the majority from the Orbiter as well as EMU unless Orbiter H₂O dumps are specifically controlled).

For average metabolic rate (1000 Btu/hr), history and analysis indicate that the EMU steam cloud dissipates within 3 feet of the PLSS. This is an upper limit with envelope size being a function of heat rejection rate.

The only guaranteed method of insuring near zero steam contamination is in removing the water sublimator loop and providing thermal control via either an umbilical or heat transfer device. The umbilical, while apparently a simple solution, proves unattractive due to the management problem associated in zero gravity. Considering that in many instances the EVA crewmember will be required to transverse a distance of many meters, the umbilical becomes impractical in length due to the possibility of snag and eventual puncture. In addition, for distances greater than a few meters the umbilical becomes cumbersome and difficult to manage.

EMU Leakage

Since the bulk of the gases have low condensation temperatures (CO₂ 167°K, N₂ 90°K, and O₂ 77°K) they present no problem on uncooled sensors. For cooled sensors the primary problem is water condensation.

EVA Crewmember Safety

Payload users have expressed concern for crewmember safety in areas of microwave radiation and ionizing radiation. Microwave radiation originates from the orbiter antennas, which produce a radiation beam. During flight the following antennas are active:

<u>S-Band (1.7 - 2.2 ghz)</u>	<u>Locations</u>	<u>Aperture</u>	<u>Power</u>
Payload Bay (PLR)	Cabin Top	-	1 watt
Hemi	Cabin Top	1 - 3 in. rectangular cavity	10 watts
Hemi	Cabin Bottoms	1 - 3 in. rectangular cavity	10 watts
Quads - Phase Array Steerable	Cabin Sides	7 - 3 in. rectangular	50 watts & 5db within 5° of beam C/L
<u>Ku-Band (15 ghz)</u>			
Tracking & Data Relay Satellite (TDRS)	Forward PLB Bulkhead	36 in. dish	30 watts & 38 db within 1.5° of beam C/L

Human safety limits are: unlimited exposure to power densities below 10 mw/cm², and exposure to less than 25 mw/cm² for up to 25 minutes. Thus, there is a minimum distance from the antennas which guarantees exposure to less than the safety limits. The minimum long term safe distances from the S-Rand hemis, quads and Ku-Rand and TDRS antennas are 4 in., 55 in., and 324 ft respectively considering near and far field effects.

A mission rule is in place that requires turning off nearby antennas during EVA. Discussion of microwave radiation safety procedures is planned to be addressed in the "Ionizing Radiation Evaluation Study". Payload designers may wish to contact Mr. M. Rodriguez of CSD for this information.

Ionizing Radiation

Planned or backup EVA in equatorial orbit will be timed to minimize exposure to the South Atlantic Anomaly (SSA), even though it may miss the highest energy portion of the SAA for approximately 18 out of every 24 hours. Timing in polar orbits is less practical because the orbiter will pass through the polar horns approximately every 15 to 30 minutes.

Other EMU Factors

The EMU is designed and has been tested to meet a requirement to operate in the presence of an RF field intensity of 1 volt/meter over the frequency range of 10 KHz to 10 GHz. The EMU does not present any EMI anomalies and is not foreseen to affect any payload electronics.

Payload Interfaces Summary

EMU environments can only be a problem to an uncovered sensor system and of such systems only cooled systems have a known definite problem. The significance of EVA contaminants compared to the Shuttle Orbiter is as follows:

- Particulate generation surface area of EVA equipment 1/500 Shuttle
- Water vapor from EVA equipment 1/30 Shuttle
- EMU leakage gas 1/25 Shuttle cabin leakage

This shows any EMU contamination is negligible when compared to the contaminant envelope produced by the Shuttle Orbiter. Payload designers who are planning payloads sensitive to currently defined contamination levels should contact Mr. James Jaax of NASA/JSC Crew Systems Division for evaluation of requirements.

Supplemental EMU Capabilities

Analysis and tests have demonstrated that the present EMU is capable of performing the standard satellite servicing tasks (e.g. module replacement, appendage retraction, override of latches and release mechanisms). However, satellite servicing tasks need not be constrained by current capabilities, since the EMU is flexible enough to adjust to a myriad of satellite servicing operating conditions. R&D programs currently exist to demonstrate concepts for prebreathe elimination and water vapor venting elimination. The following paragraphs describe conditions and program status of each.

"No-Prebreathe" EMU

Early EVA planning for supporting STS flights and satellite servicing calls for conducting EVA at 4.0 psia from a 14.7 psia Shuttle Orbiter cabin. To preclude "the bends", a painful and potentially dangerous physiological condition, STS crewmembers prebreathe pure O₂ for 3 to 4 hours to purge body tissues of dissolved N₂, the prime constituent of bends bubbles. However, prebreathing has several drawbacks: the crew considers the Portable Oxygen System (POS) restrictive to intravehicular activity (IVA), and denitrogenation effectiveness can be significantly reduced during EMU donning by inadvertently taking just one or two breaths of air, increasing likelihood of bends considerably unless specific (and cumbersome) procedures are followed rigorously.

Planning for OFT side-steps prebreathing by requiring reduction of cabin pressure to 9 psia for approximately 12 hours prior to EVA, which promotes sufficient washout of dissolved gases from tissues to minimize likelihood of bends. This is not a permanent solution, because it does not address many Orbiter, payload, operational, and EVA issues relevant to both operational STS flights and satellite servicing.

The present Shuttle EVA baseline combines use of a 10.4 psia cabin pressure with a 4.3 psia EMU to eliminate the POS and prebreathe. This status will not harm payloads or orbiter electronics, yet still requires that the cabin remain at 10.4 psia for 6 hours prior to EVA.

However, raising the EMU pressure to 8.0 psia will permit use of 14.7 psia cabin pressure even during EVA support. This would lift current constraints and resolve conflicts in assigning pressure sensitive payloads to flight with planned or backup EVA. An 8.0 psia EMU will provide mission flexibility as EVA events increase.

Additionally, an 8 psia EMU will provide "quick reaction" EVA and additional crewmember safety. NASA has been directing 8 psia soft goods assembly CR&D programs to provide alternates and evaluate technologies for the necessary SSA mobility for 8 psia.

Non-Venting Thermal Control Subsystems

The only significant alteration of the free space environment caused by the EMU is due to the venting of the steam used for cooling. Specifics concerning water contamination have already been described in the payload interface section. NASA has conducted many programs to develop non-venting thermal control subsystems, with the most recent being an on-going program to provide a 4-hour non-venting thermal control subsystem. This regenerative system will have the dual benefit of eliminating potential payload EMU H₂O contamination and reduce the expendable mass required by the EMU system.

Enhanced Glove Development

NASA is also developing technology which will significantly improve the mobility of the EMU glove. This effort comes from the realization that hand mobility is the key to effective EVA work.

Summary

The EMU will serve as an important tool for both planned and contingency EVA. The EMU is capable of performing the standard satellite servicing tasks (e.g., module replacement, appendage retraction, override of latches and release mechanisms). However, satellite servicing tasks need not be constrained by current capabilities, since the EMU is flexible enough to adjust to a myriad of satellite servicing operating conditions.

The technology used in the EMU system is by no means static. The technical solutions to manned utilization of space are dependent on the vehicle services available, the understanding of the needs, and the resources available. Payload designers in planning for satellite servicing should not presuppose EMU operating conditions and capabilities, but be advised to contact appropriate NASA personnel before solidifying payload design concepts. None of the technology elements of the EMU are static and continued refinement of EMU technology shall proceed in concurrence with satellite servicing demands.

73

TELEOPERATOR MANEUVERING SYSTEM

JAMES R. TURNER
MARSHALL SPACE FLIGHT CENTER
Phone: (205) 453-2817
(FTS) 872-2817

11 6 11 11 11

50

TELEOPERATOR MANEUVERING SYSTEM

The Teleoperator Maneuvering System (TMS) will perform a variety of missions as a mini-tug/upper stage. Operating out of the Orbiter, it may be controlled either from the AFD (Aft Flight Deck) or from the ground.

Typical missions are: Payload Placement, Retrieval, Servicing (module exchange or refueling) Viewing and large space systems assembly support.

3073

TELEOPERATOR MANEUVERING SYSTEM (TMS) PROGRAM

OBJECTIVES

- PROVIDE A REMOTELY CONTROLLED, FREE-FLYING, MINI-TUG ORBITAL SERVICE VEHICLE CAPABLE OF PERFORMING A WIDE RANGE OF REMOTE SATELLITE SERVICES MISSIONS.
- ENHANCE THE ORBITER'S CAPABILITY AND EFFICIENCY IN THE DELIVERY OR RETRIEVAL OF PAYLOADS TO HIGH ALTITUDE ORBITS.

TMS MISSION APPLICATIONS

- HIGH ALTITUDE PAYLOAD DELIVERY/
RETRIEVAL
- PAYLOAD PLANE CHANGES
- SATELLITE MODULE REPLACEMENT/
SERVICING
- SATELLITE REFUELING
- SPACE DEBRIS CAPTURE/DISPOSAL
- REMOTE PAYLOAD VIEWING (TV)
- LARGE STRUCTURES ASSEMBLY
SUPPORT
- MULTI-PURPOSE PROPULSION
MODULE UTILITY

TMS PROJECT SCHEDULE

The major activities and phasing of the ongoing TMS project are reflected by the facing schedule.

Phase "A" activities are currently in process which are intended to drive out the system requirements and to define systems concepts in sufficient depth as to initiate the formal RFP for Phase "B".

Authority to proceed is being sought for FY-1985 for the primary system capability (i.e. delivery and subsatellite support) which would have first beneficial use in 1987. Subsequent authority in FY-1986 for the retrieval kit would enable spacecraft retrievals to begin in 1988. Authority to design and construct the Servicer Kit in the same general time period would enable the TMS to repair disabled spacecraft on-orbit and to reboost them to their operational orbit for an extension of life by 1988.

TELEOPERATOR MANEUVERING SYSTEM (TMS)

807-82

J. TURNER PS04
FEB. 28, 1982

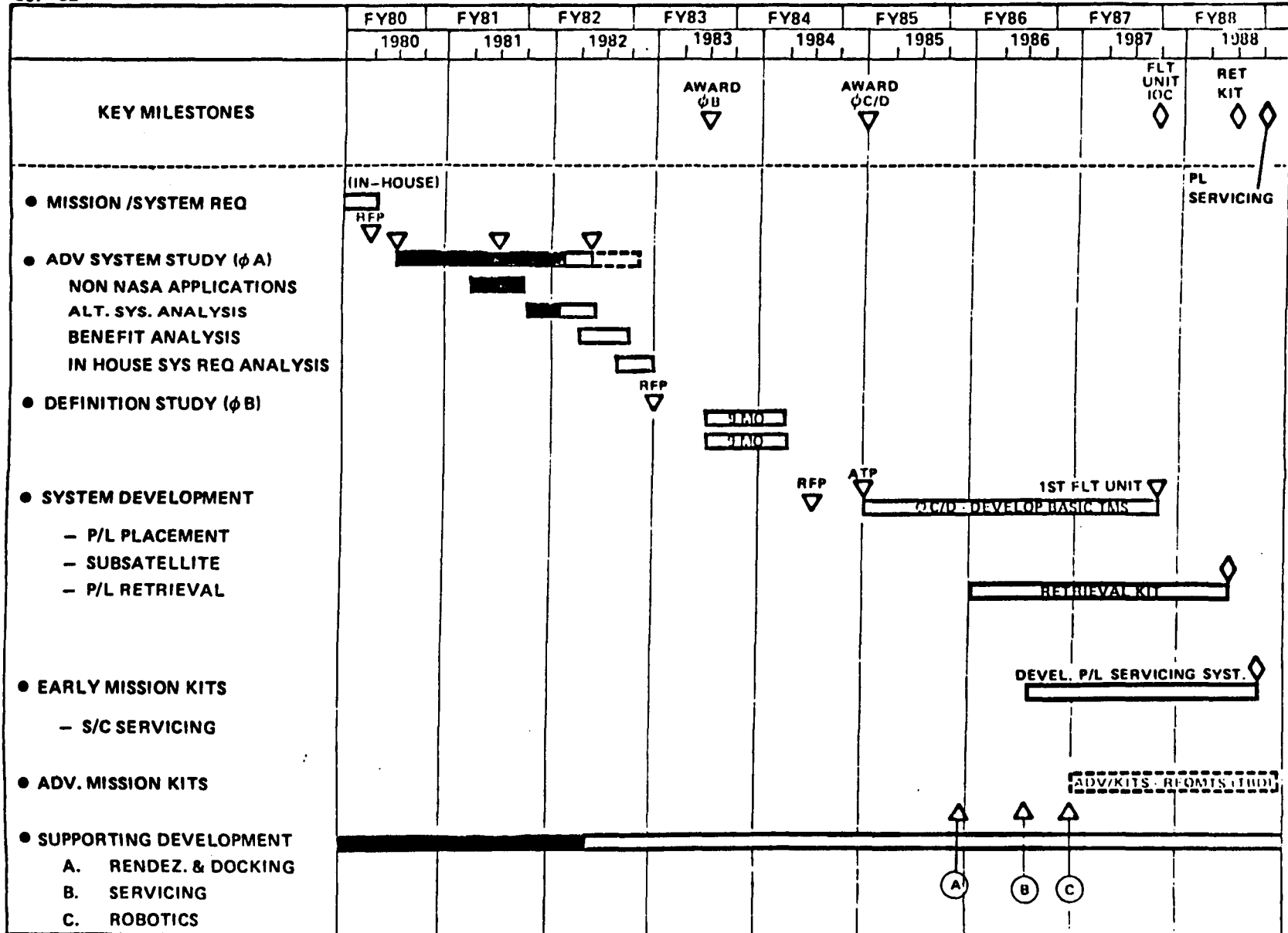

77

ORIGINAL PAGE IS
OF POOR QUALITY

PROJECT PHASING

The design phasing is reflected by this chart which shows three distinct phases of capability.

ERA-1 capability will consist of payload placement, retrieval and sub-satellite support.

ERA-2 capability will be obtained by the addition of advanced mission kits. These specialized kits will enable the TMS to support large space systems and spacecraft servicing by direct module exchange as a logistic vehicle or the transfer of fluids and modules via remote manipulators.

ERA 3 capability will extend TMS operations to geosynchronous orbits when delivered by an OTV. This era will require longer system duration times, orbital storage, and higher degrees of autonomy.

TELEOPERATOR MANEUVERING SYSTEM (TMS)

- TMS:**
- **SMALL, REMOTE-CONTROL PROPULSION & SERVICE UNIT TO EXTEND SHUTTLE CAPABILITIES**
 - **TMS CAPABILITIES TO BE INTRODUCED IN INCREMENTAL FASHION**

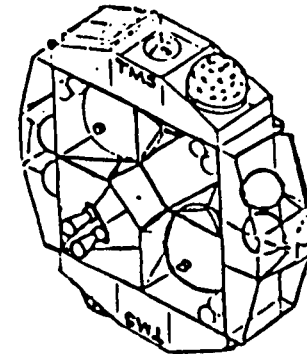

ORIGINAL PAGE IS
OF POOR QUALITY

79

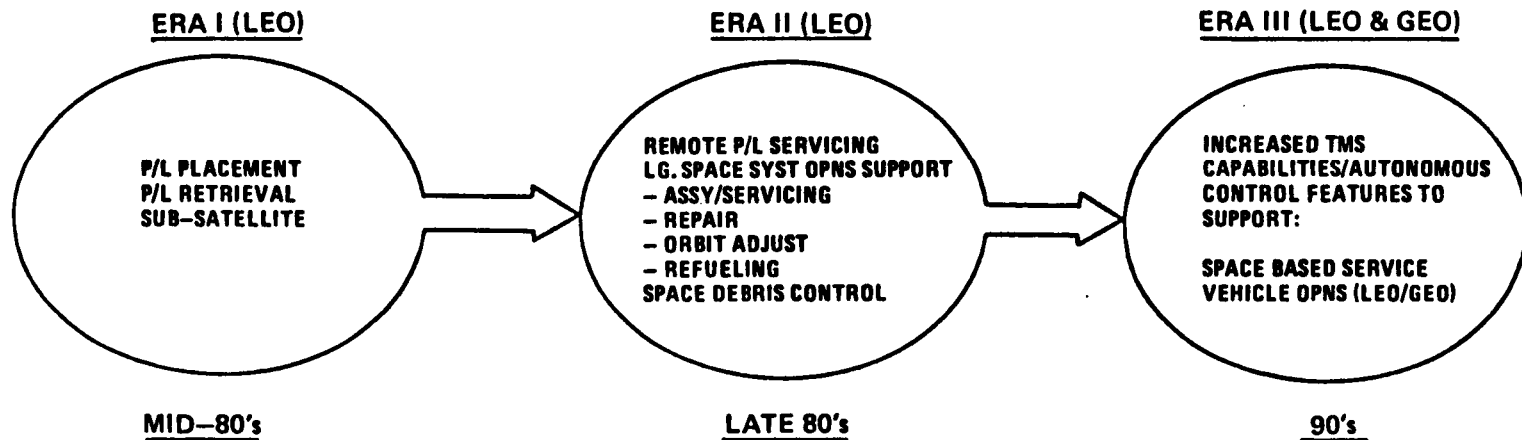

DESIGN PHILOSOPHY

A building block philosophy/methodology is planned; thus permitting the evolution of capability as it is needed and delaying cost as much as possible.

The system is being designed with a wide range of applications in mind to maximize its application and to minimize the transportation cost.

Other factors being considered are: standardized interfaces, safety, contamination, and system reusability.

TMS Design Philosophy

- | | |
|--------------------------------------|--|
| • A Building-Block Approach | A basic core vehicle with propulsive communication, and servicing kit add-on to evolve with mission needs |
| • Minimize Early-Year Costs | 1985-1986 missions with core vehicle |
| • Multipurpose | Enhance/augment STS by providing flexibility in payload delivery altitudes inclinations, manifesting, and support operations |
| • Reduce User Charges | Minimize weight and length in configuration trade studies |
| • Control Flexibility | Mix of autonomous and man-loop control in orbiter and appropriate ground stations for periodic or real-time control of TMS |
| • Standardize Interfaces | Minimize complexity of interfaces between payloads, the orbiter and launch facilities. |
| • Safe and Contamination-Free | TMS designed to the safety aspects of the man-rated Shuttle and to avoid STS and payload contamination |
| • Cost-Effective | Reuseable with goal for 10-year life with limited refurbishment and maximum use of developed hardware |

81

ORIGINAL PAGE IS
OF POOR QUALITY

TELEOPERATOR MANEUVERING SYSTEM

The TMS consists of three segments: the vehicle, the Shuttle Orbiter payload bay cradle with Airborne Support Equipment (ASE), and the Aft Flight Deck (AFD) control station.

- O The 13 foot diameter, 37 inch thick vehicle is a reusable remotely controlled free flying vehicle capable of satellite servicing, placement and retrieval. The TMS flies preprogrammed trajectories as well as being controlled or reprogrammed from the AFD or the ground. Approximately 1 million lb-sec of energy are available from the hydrazine propellant with an option to upgrade to 1.6 million lb-sec of N_2O_4/MMH bipropellant.
- O The lightweight ASE cradle may be conveniently positioned along the payload bay length where it is attached using the standard sill and keel fittings. The cradle supports the TMS during the launch and reentry phases and houses the antennas, communication, video and other avionics ASE necessary for vehicle man-in-loop (MIL) control from the Orbiter's AFD.
- O The equipment on the AFD is located at console L-11. It consists of a set of hand controllers for TMS proximity operation maneuvering and two cathode ray tube (CRT) screens and keyboards. Data is displayed for vehicle checkout and health status and video display is provided for docking and servicing. All of the data are reconstructed and processed by the cradle ASE prior to receipt at the AFD. The AFD installation is mission dedicated; however, the entire TMS operation is autonomous to the Orbiter systems except for in-bay power and guidance initialization through the Orbiter multiplex bus. Recorded data will also be stored by the Orbiter.

Teleoperator Maneuvering System

83

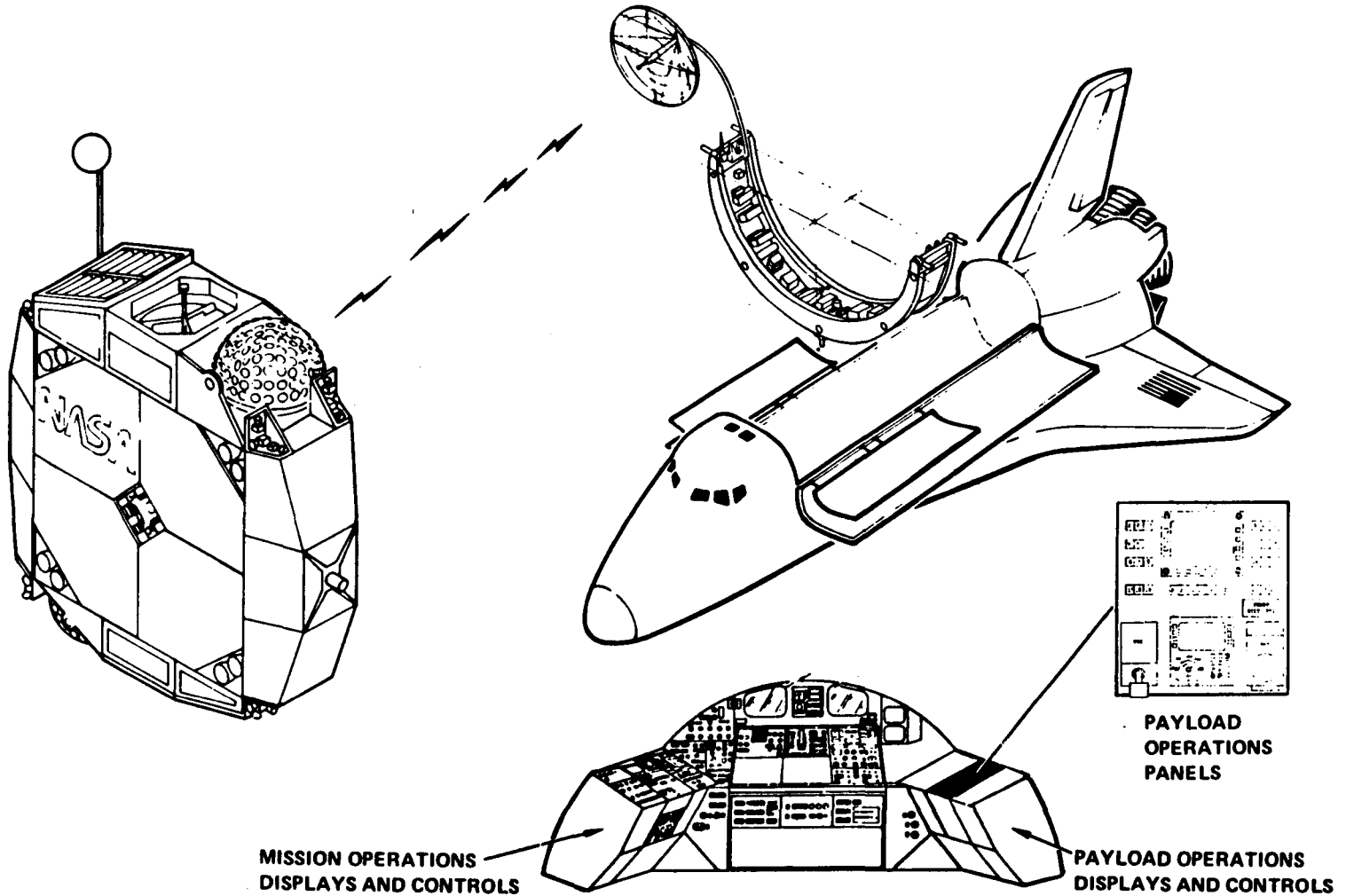

ORIGINAL PAGE IS
OF POOR QUALITY

TMS - AFT FACE

This is a perspective view looking at the aft face of the TMS with the subsystem components and other items identified. Vehicle dimensions and weights are listed. The Remote Manipulator System (RMS) grapple fixture is the standard interface for the RMS. The TMS is deployed from and replaced in the payload bay by the RMS. Two (2) 30 inch diameter Electronically Steerable Spherical Array (ESSA) antennas operating on S-Band are located diametrically opposite on the TMS to provide 4 steradian coverage. Twenty-four 15 pound thrusters comprise the RCS which provides roll attitude control during main burn and rotational and translational control during rendezvous and man-in-the-loop operations. Helium gas is used to pressurize the propellant tanks. The spherical pressurant tanks are located on each side of the vehicle. A multi-use compartment is also located in this area as contingency volume. Three trunnion fittings are present (one on each side and one on the bottom) on the TMS for attachment to the ASE cradle. Avionics compartments are on the upper and lower segments of the TMS. Thermal control louvers are used to dissipate heat from the electronic equipment. The aft end of the docking port is shown. A device such as an RMS end effector extends forward when docking with a spacecraft. The eight (8) throttleable thrusters are located in a square pattern. Four or eight thrusters can be operated between the 25 and 125 lbf level with the total thrust range varying from 100 lbf minimum to 1000 lbf maximum.

Teleoperator Maneuvering System

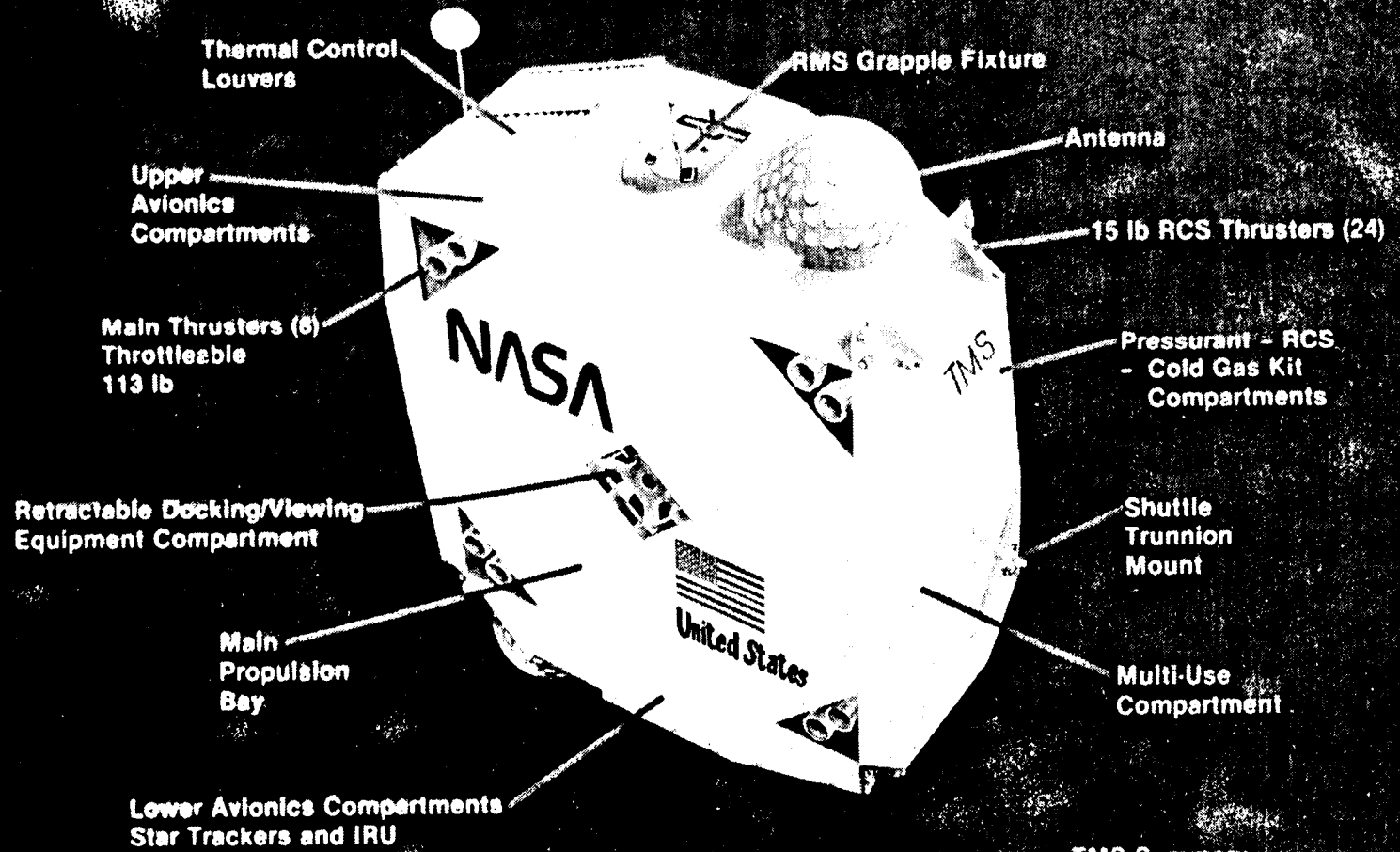

TMS Summary

Length	37 in.
Diameter	156 in.
Weight	7,500 lb
Propellant Only	5,000 N ₂ H ₄

85

ORIGINAL PAGE
BLACK AND WHITE PHOTOGRAPH

TMS - FORWARD FACE

This is a perspective view of the forward face of the TMS. The docking adapter can be seen in its fully extended position, 24 inches. The end effector is identical to the Shuttle Orbiter RMS end effector although other types may be incorporated. The video and lighting system are located as shown and are used for docking, viewing, and servicing. Also required in the docking kit is the range/range rate radar which has a 9 inch diameter antenna shown deployed outward from the TMS body. Star tracker field of view ports are shown in the lower avionics bay. The lower keel fitting has been offset to not obstruct their field of view. A multi-layer insulation blanket will cover the TMS to maintain thermal balance.

98 The monochrome TV camera provides a redundant video imaging system capable of viewing a target during rendezvous and final docking operations. One of the cameras is mounted on a pan/tilt base to aid in acquisition and provide additional viewing flexibility.

Flood lights are provided for dimly lit or night scenes illumination.

Teleoperator Maneuvering System

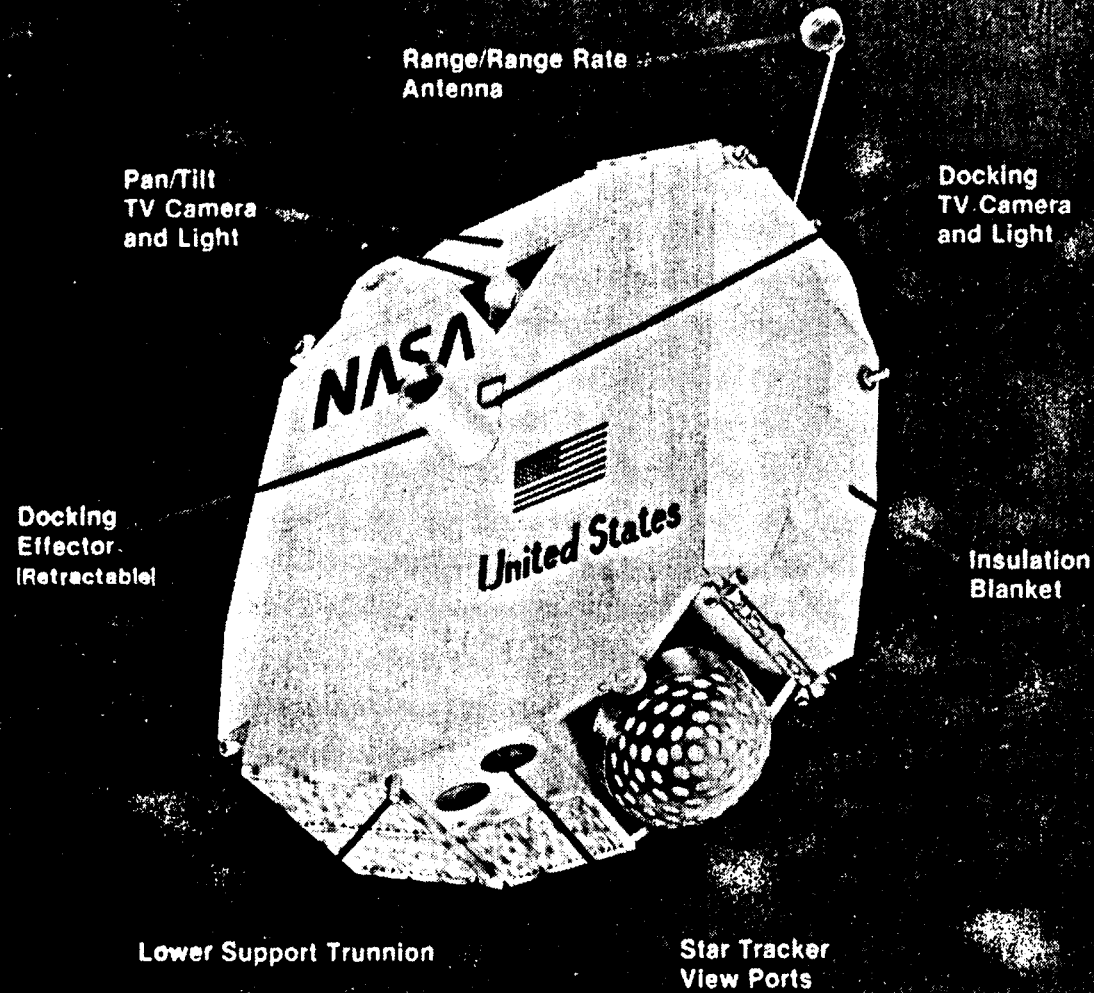

87

ORIGINAL PAGE
BLACK AND WHITE PHOTOGRAPH

TELEOPERATOR MANEUVERING SYSTEM EVOLUTION

88

The design philosophy of a building-block approach is reflected in the lower half of this chart and the commonality matrix at the upper right. The standard or baseline TMS is denoted as number 4. Modular compartments of this baseline may be used up-front to build various sized propulsion modules with hydrazine propellant quantities of 875 pounds, 2500 pounds or 5000 pounds as required. Incorporation of the avionics brings the vehicle to its full capability, and even that can be done progressively. For example, docking kit equipment such as range/range rate radar and TV system with video bandwidth compression may be added to the placement capability at a later date when needed. If cold gas RCS is needed because of contamination considerations, it can also be added in kit form. Examples of subsatellite operations and satellite servicing are shown to the right where subsatellite solar arrays and servicing kits are added to the basic vehicle.

The baseline uses monopropellant hydrazine. Comparing monoprop and biprop results in a "toss up" between the two propellants. Monoprop was selected because of acceptable performance in the required energy regime, lower development costs and risk and user familiarity. However, in order to be responsive to changing requirements, the monoprop vehicle has been designed to easily switch to a biprop system as shown in the upper half of the chart. The propellant tanks would remain unchanged except to substitute surface tension devices for bladders and the required plumbing changes. The vehicle would hold 5700 pounds of biprop. The RCS would remain monoprop or cold gas. These concepts are shown in configurations numbered 6 through 8.

Teleoperator Maneuvering System Evolution

BI PROPELLANT N₂O₄/MMH

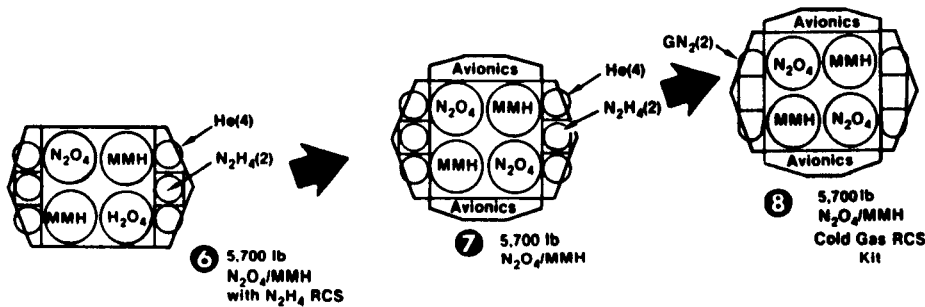

MONOPROPELLANT N₂H₄

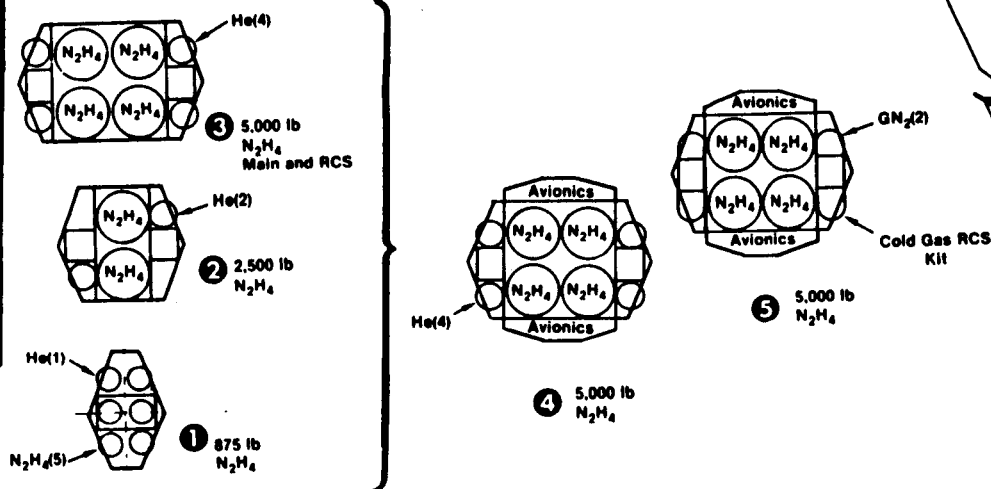

PROPULSION MODULES

- Placement, Reboost, Controlled Reentry
- Subsatellite (Short Range Free Flyer)

P1-1854-1

COMMONALITY

Configuration Number	Main Structure	RCS Module Structure	Avionics Modules	Main N ₂ H ₄ Tanks	N ₂ O ₄ /MMH Tanks	GN ₂ Cylinders	He Spheres	N ₂ H ₄ Spheres	N ₂ H ₄ RCS Thrusters	N ₂ H ₄ Main Thrusters	N ₂ O ₄ /MMH Thrusters
1		X					X	X			
2		X		X			X				
3	X	X		X			X		X	X	
4	X	X	X	X			X		X	X	
5	X	X	X	X		X			X	X	
6	X	X			X		X	X	X	X	X
7	X	X	X				X	X	X	X	X
8	X	X	X		X	X			X	X	X

*Optional

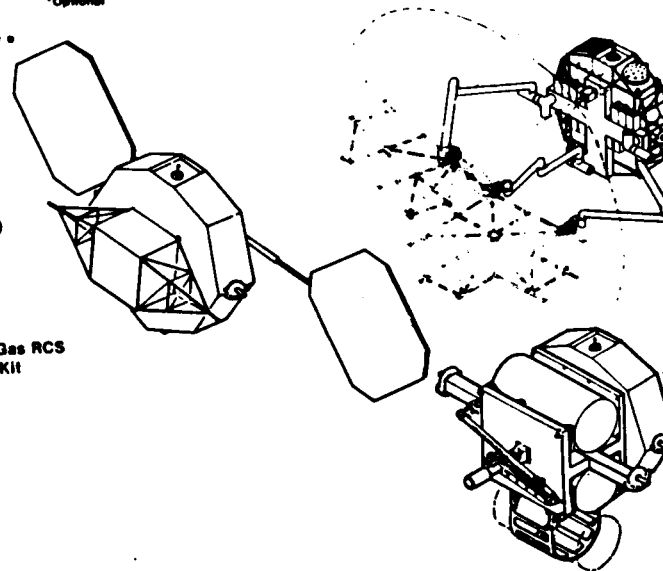

REMOTE SATELLITE SERVICES

- Retrieval (Satellite or Payload/Experiment)
- Long Range Subsatellite Operations
- Maintenance, Servicing and Repair
- Structure Assembly

ORIGINAL PAGE IS OF POOR QUALITY

TMS APPLICATIONS

A wide range of TMS applications are shown and implied on the facing page.

Basic Shuttle payload delivery flexibility is greatly enhanced. Multiple payload delivery to various orbital altitudes may be readily accommodated.

Launch window make-up is possible as well as considerable plane change. Some representative combinations of plane change and delivery capability are shown - also, representative retrievals which make servicing and debris removal possible.

The capability matrix is further enhanced by viewing and logistic support.

TELEOPERATOR MANEUVERING SYSTEM (TMS) APPLICATIONS

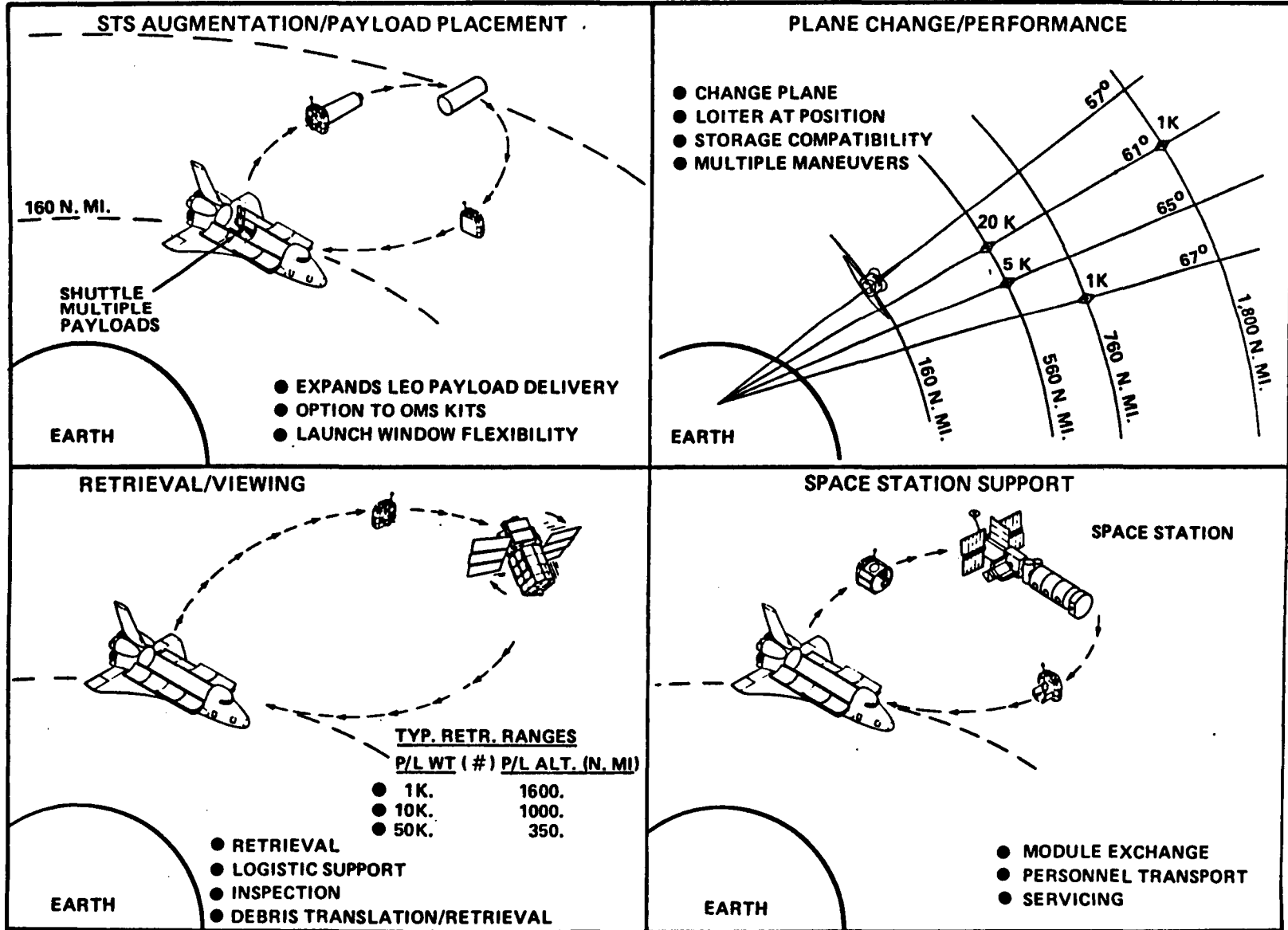

16

ORIGINAL PAGE IS OF POOR QUALITY

TYPICAL TMS PERFORMANCE ENHANCEMENT OF STS

The chart presents performance as cargo weight which can be transported to circular orbit altitude. The dashed curves represent Shuttle capability with integral OMS, and with 1, 2 or 3 OMS kits. The solid curve is TMS performance staged from the Shuttle at 160 nautical miles. TMS performance is shown for the baseline 4-Tank vehicle. The curve represents net payload weight which can be transferred from 160 nautical miles to higher circular orbits. The beginning of the TMS curve to the left represents zero TMS fuel. Fuel is added along the straight portion of the curve until full fuel is reached where the curve breaks downward. At this point payload is reduced to achieve higher altitude.

The chart demonstrates the efficiency of staging a TMS/Payload from the Orbiter at 160 nautical miles versus direct ascent to altitude by the Orbiter. The example point (within the diamond) shows the Orbiter requires two OMS kits to take 20,000 pounds to 425 nautical miles. In contrast, an off-loaded 4-tank TMS can take 20,000 pounds to 425 nautical miles, and on the same flight to 160 nautical miles the Orbiter can bring up an additional payload in excess of 31,500 pounds.

TYPICAL TMS PERFORMANCE ENHANCEMENT OF STS

- FULL PERFORMANCE ORBITER
- 4-TANK MONOPROPELLANT TMS
- TMS STAGED FROM 160 nm ALTITUDE
- STS FROM ETR TO 28.5° INCLINATION

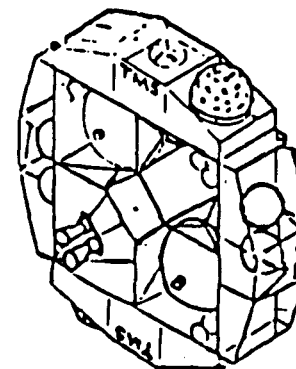

ORIGINAL FACE TO OF POOR QUALITY

93

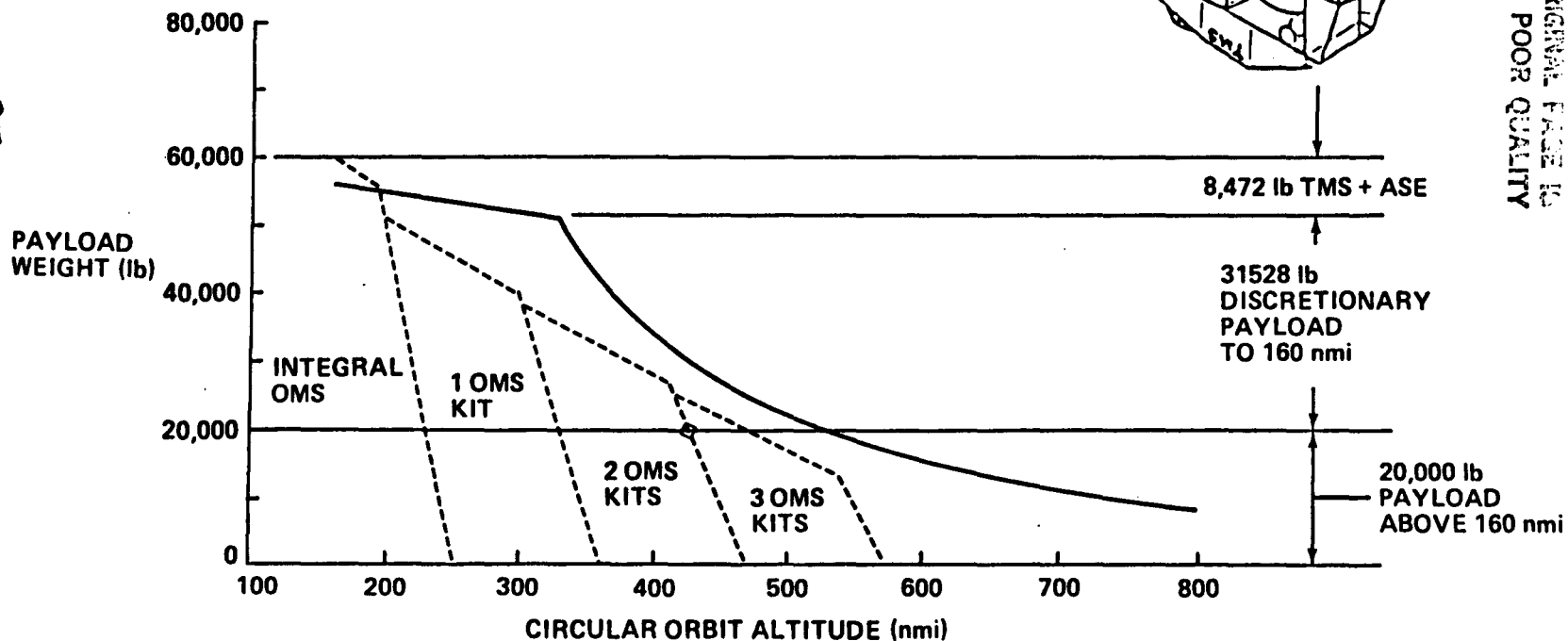

TMS PERFORMANCE ENHANCEMENT OF STS

(BIPROP TMS)

The facing page shows the Orbiter delivery capability increase which is possible utilizing a stretched version of the TMS capable of carrying 6,713 lb. of bipropellant (N_2O_4/MMH).

Some interest has been expressed in a vehicle in this size class. This system is approximately four inches longer than the baseline system.

Also shown is the performance capability of a configuration consisting of a TMS plus a second set of tanks (13,426 lb. propellant).

TYPICAL TMS PERFORMANCE ENHANCEMENT OF STS

- NEAR-TERM PERFORMANCE ORBITER
- 6713 LB BIPROP/10,401 LB IGNITION WEIGHT TMS
- TMS STAGED FROM 160 NM
- STS FROM ETR TO 28.5° INCLINATION WITH STD MECO (ET IN INDIAN OCEAN)

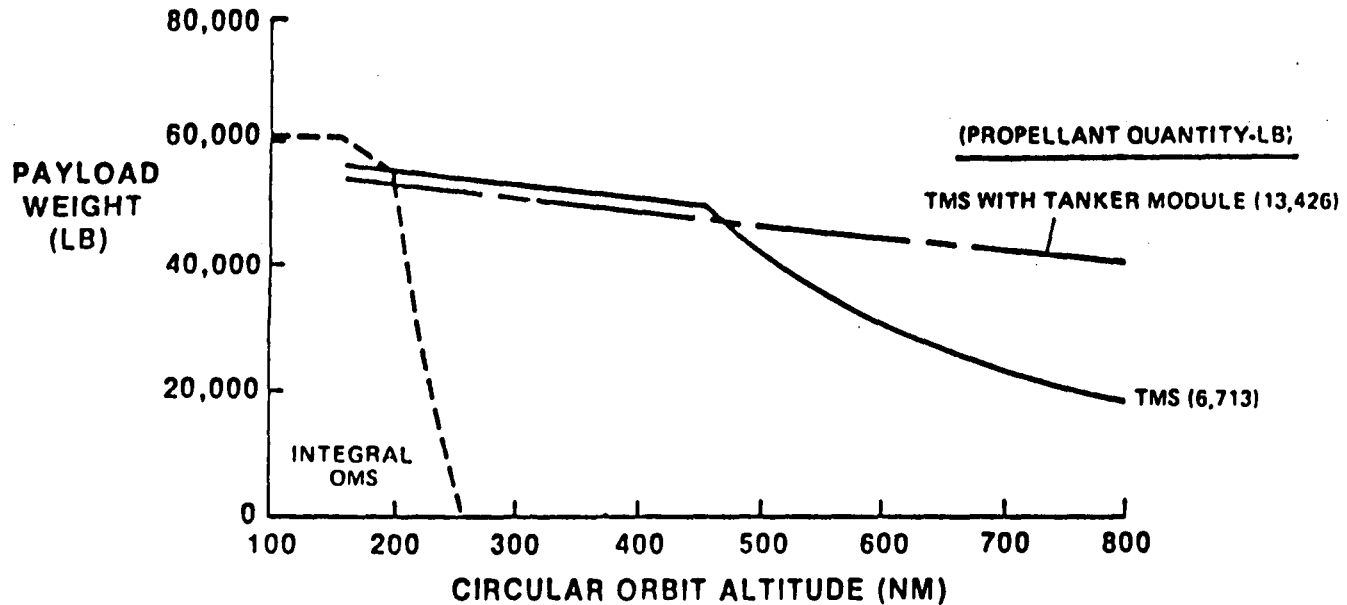

ORIGINAL PAGE IS
OF POOR QUALITY

95

RATIONALE FOR A TELEOPERATOR MANEUVERING SYSTEM

The chart presents a rationale for adding a Teleoperator Maneuvering System (TMS) to the STS. The Orbiter carries its largest payload to low earth orbit (LEO) in the range of 150 to 220 NM. Ascent to higher altitudes with integral OMS fuel or with OMS kits decreases the total payload delivered to orbit. Additional cost is also involved when using OMS kits. Since a majority of payloads (71%) require placement above 220 NM, the most efficient means for this placement will minimize user cost. Staging a payload from low altitude with a TMS maximizes payload brought to orbit (maximum sharing) and avoids the cost of OMS kits to reach the higher altitudes desired by a large number of payloads.

RATIONALE FOR A TELEOPERATOR MANEUVERING SYSTEM

ORBITER TRANSPORTS LARGE MASS TO LOW EARTH ORBIT

- LOW ALTITUDE (150-220 N.M.) MAXIMIZES PAYLOAD
- HIGHER ALTITUDE DECREASES PAYLOAD
- OMS KITS ARE INEFFICIENT AND INCREASE USER COST IN 220-680 N.M. ALTITUDE RANGE

FEW PAYLOADS AT LOW ALTITUDE IN 1985-1995 ERA

150 - 220 N.M.	5%
220 - 1500 N.M.	71%
1500 - GEOSYNCHRONOUS	24%

- CONCLUSIONS:
- MEDIUM ALTITUDE IS INEFFICIENT USER COST DOMAIN FOR ORBITER, OR BEYOND ITS CAPABILITY
 - TMS REDUCES USER COST BY ALLOWING MORE PAYLOAD SHARING AND EXPANDS CAPABILITY OF STS BEYOND SHUTTLE/OMS KITS

TMS MANEUVER CAPABILITY AT GEO

The facing performance chart reflects the TMS geosynchronous maneuver capability when delivered by an OTV vehicle.

Current study efforts are focusing on the feasibility of long term geosynchronous TMS storage.

In such role the TMS could become a valuable aid to servicing and assembly support to major orbiting systems and as a logistic/refueling system to fleets of GEO spacecraft.

TMS MANEUVER CAPABILITY AT GEOSTATIONARY ORBIT

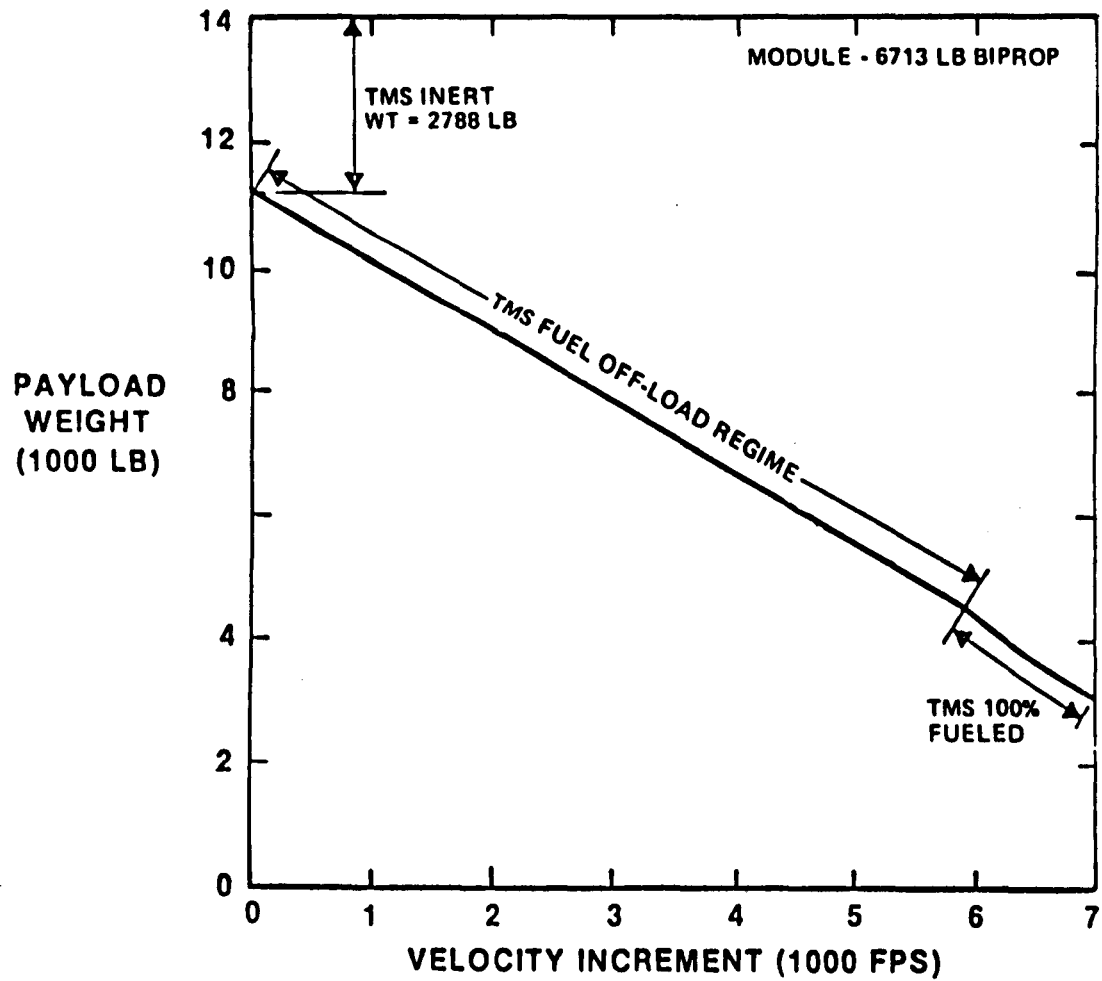

66

ORIGINAL PAGE IS
OF POOR QUALITY

ASSEMBLY SUPPORT

An important role of the TMS is the assembly support of a space platform or space station. The TMS is shown bringing a structural module to the platform for installation by an onboard space crane or RMS. In this scenario the module was delivered by the Orbiter to a lower altitude, deployed, and subsystems verified before the TMS transports it to the platform. After handoff to the platform RMS, the TMS is available to aid the assembly and to observe and inspect overall operations.

The TMS is also shown in a servicing role by delivering electrophoresis resupply units and Materials Experiment Carrier modules. These units are transported between the platform and the Orbiter.

The TMS can be space-based at the platform as depicted at the berthing station. TMS is shown berthed in a cradle similar to the Orbiter ASE cradle, which provides dedicated communications and checkout equipment. At this location the TMS can be refueled and have the batteries charged for continuing operations. Docking at the port would be accomplished with the platform RMS. Space-basing provides a quick-response capability for exploratory inspection, debris control, and rescue contingencies.

Platform Assembly Support and Servicing

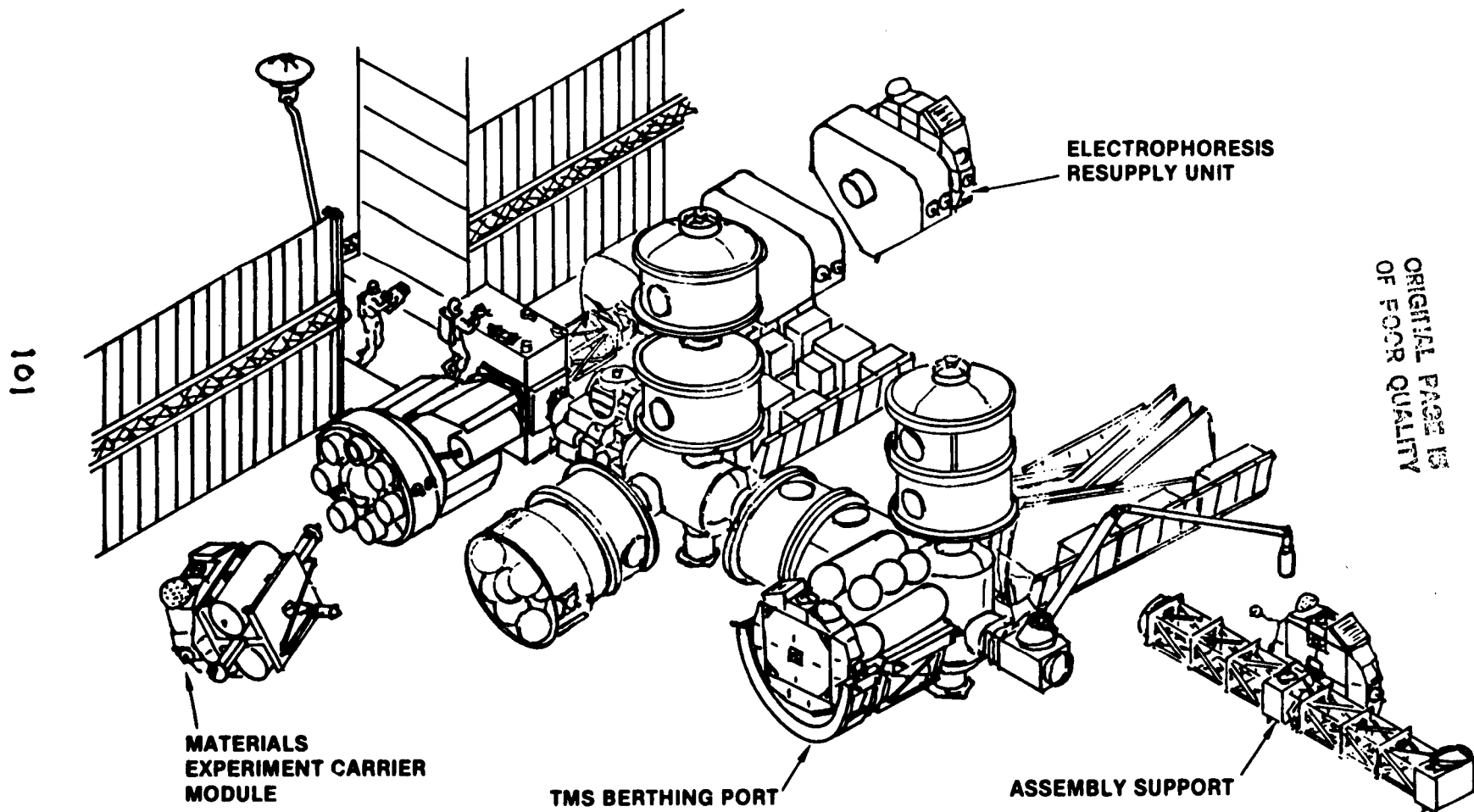

TMS DEBRIS CAPTURE

The control of space debris is becoming extremely important because the debris population is growing rapidly and personnel/equipment hazards are increasing due to expanding space operations and activity in the debris zones. The TMS offers an opportunity to control large debris through its capture and removal from space. Controlled re-entry will help ease the debris hazard by removal of spacecraft at the end of the mission.

This view shows a stabilized spacecraft captured by the TMS. The capture device, which is readily attached to the TMS as a kit, may also be used in uncooperative retrieval where the spacecraft may have uncontrolled motion. The inflatable pads would allow retrieval of the spacecraft with a minimum of structural damage. Compartmentation of the rings enhances their compliance and localizes loss of pressurization in case any compartment is punctured, as shown. This device may also be used in a rescue application.

TMS DEBRIS CAPTURE

ORIGINAL PAGE IS
OF POOR QUALITY

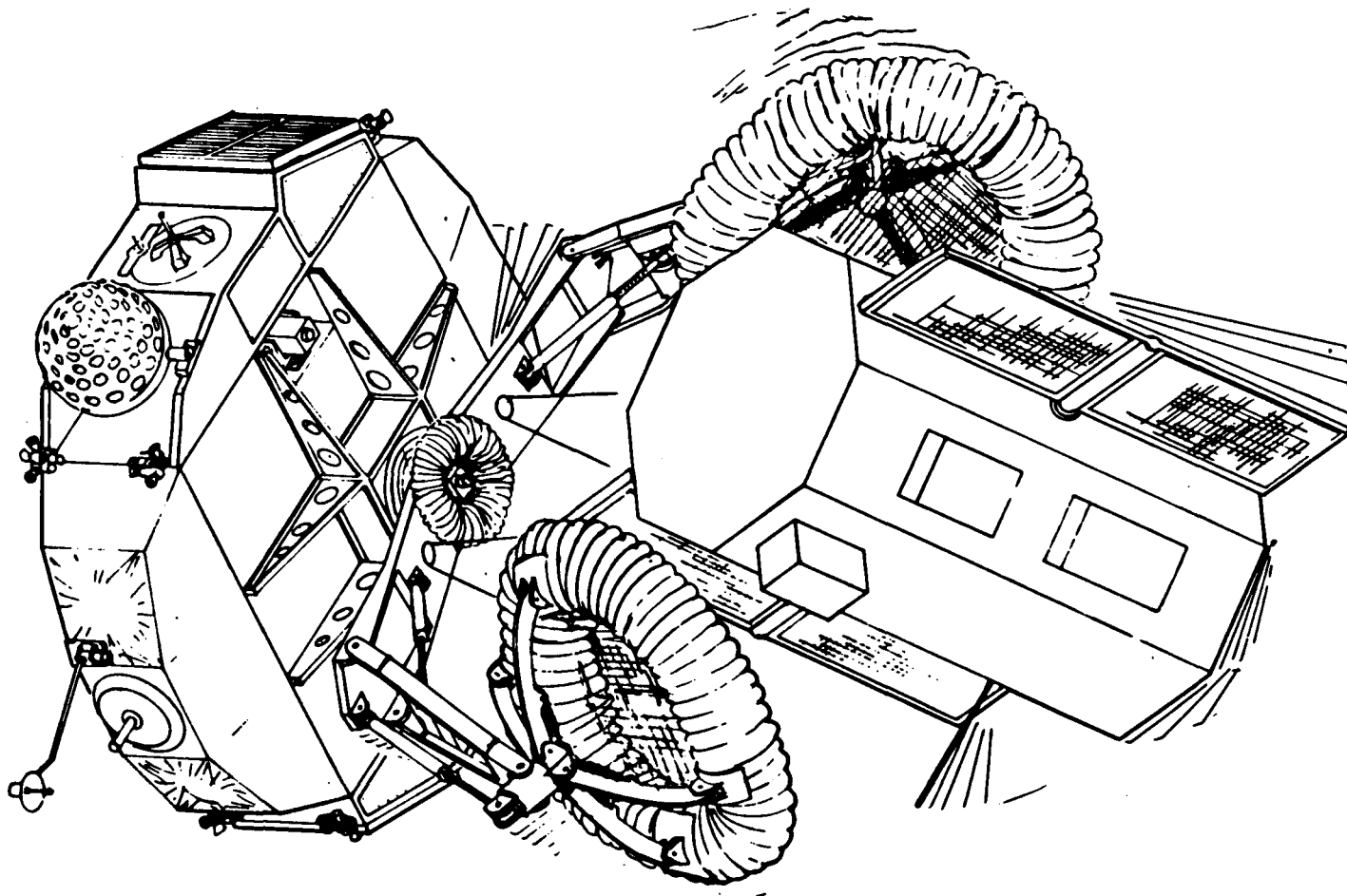

103

SPACECRAFT SERVICING

An engineering test unit of the Integrated Orbital Servicing System (IOSS) which is currently being tested and evaluated at MSFC is shown on the facing page.

This system is capable of removing and replacing major system modules by remote computer control. The system consists of a docking probe, spare module rack and a six degree of freedom manipulator system. In addition, a subtle part of the system is the system of spacecraft interface mechanisms which support the modules structurally and which make and break the electrical and fluid connectors of the spacecraft/module interface when powered by the servicer end effector.

This system is planned as the first major kit to the TMS. With the addition of this kit (and the assumed compatible spacecraft designs) the TMS will be capable of performing maintenance in a free-flying mode remote from the Orbiter.

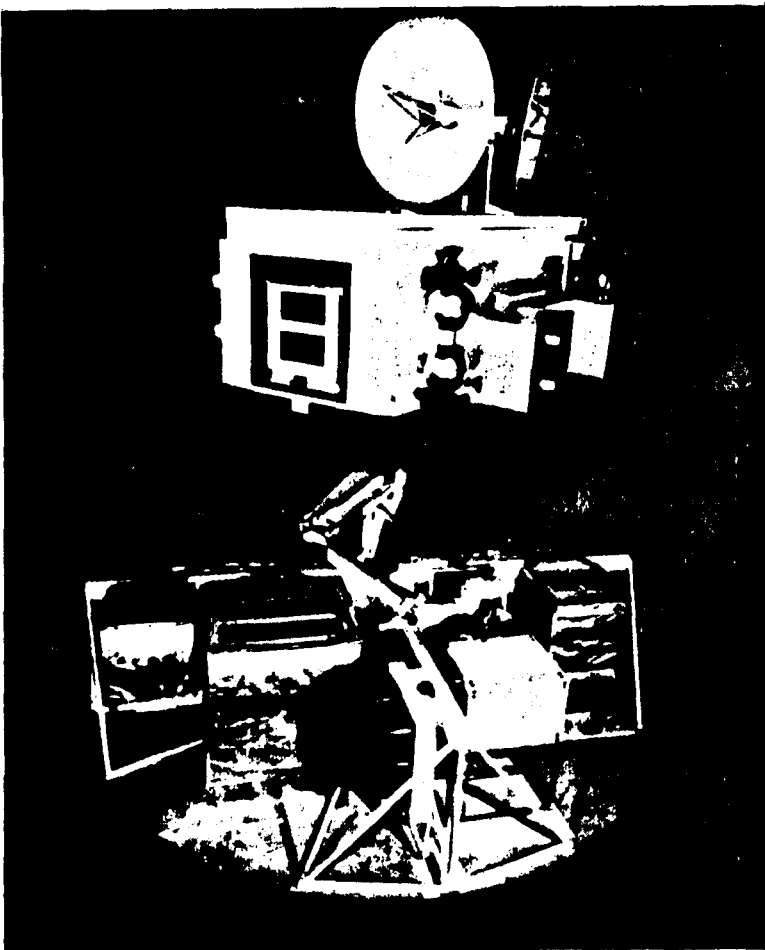

SPACECRAFT SERVICER AND STORAGE RACK

ORIGINAL PAGE IS
OF POOR QUALITY

AXAF SERVICING

The Advanced X-Ray Astrophysics Facility (AXAF) is shown here configured for servicing. In order to achieve the primary goal for continuity of observations over a 10 year period, the capability for exchange of instruments on an "on-condition" maintenance basis is "designed in". Although presently planned for return to the Orbiter cargo bay for maintenance operations most of the instrument exchange functions could be performed by TMS.

This chart shows TMS, docked to the aft end of AXAF, equipped with an instrument storage rack and the Integrated Orbital Servicing System (IOSS). The access doors of the AXAF instrumentation compartment have been opened and IOSS has removed one of the instrumentation modules from the carousel for placement in the instrument storage rack. In this illustration the instrument modules have been altered to include a centrally operated system of latches.

It is also considered feasible for TMS to exchange support systems modules mounted between the ring frames near the forward end of the spacecraft, but this would require additional docking provisions.

A specially configured storage rack would be required to accommodate the four support system modules, each approximately 40 x 40 x 20 inches. Provisions for re-stowage of the solar arrays would also be necessary.

AXAF Servicing

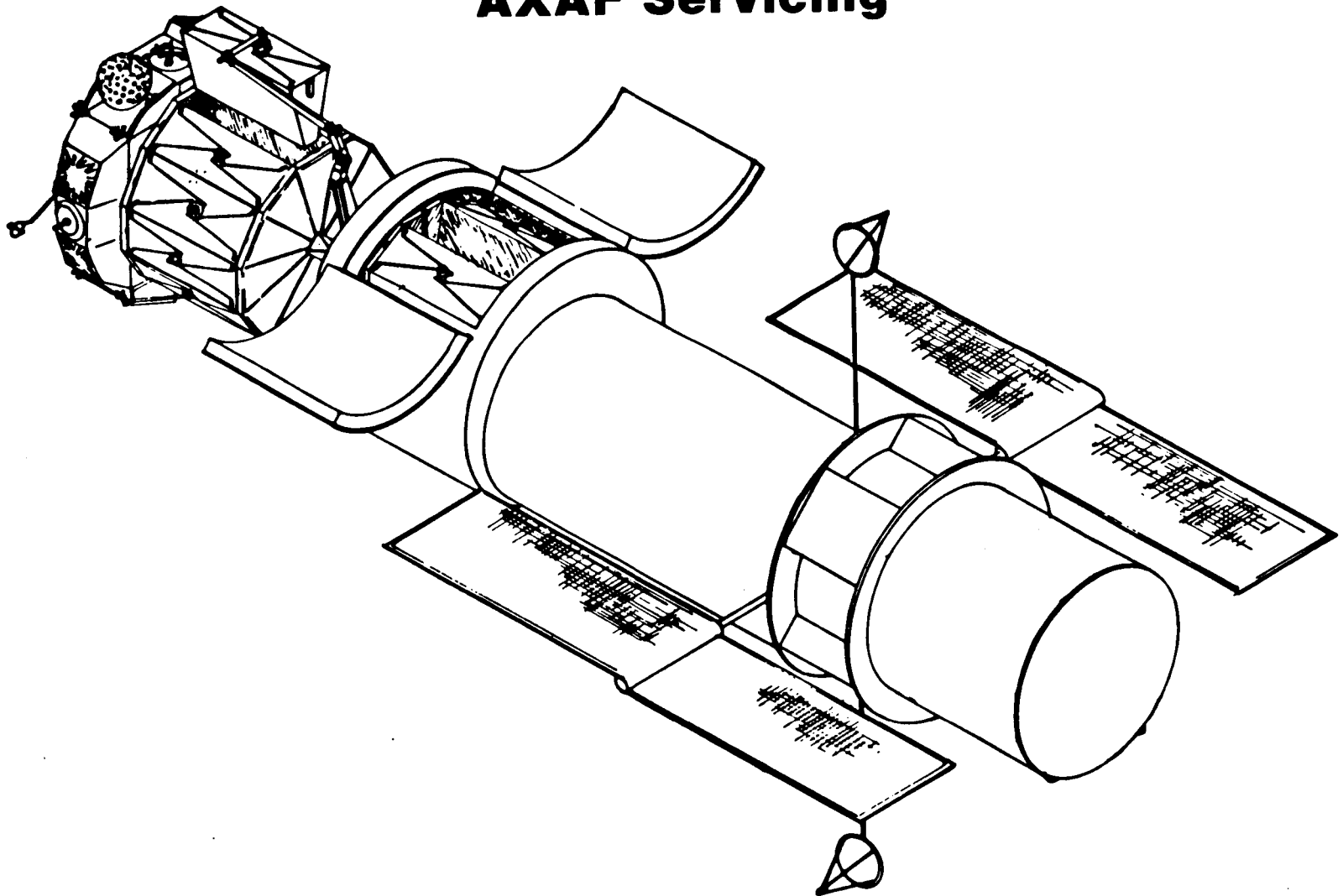

ORIGINAL PAGE IS
OF POOR QUALITY

107

SUMMARY TMS BENEFITS

The facing chart briefly lists some rather compelling statements for the near term development of a TMS system.

In summary the TMS has the promise of vastly increasing the flexibility of the Shuttle Transportation System.

Summary of TMS Benefits

- **Payload placement by TMS vastly expands shuttle capability-flexibility-utility**
- **Opportunities for 1985-1995 estimated at 305**
- **Modular TMS will evolve to broad range of mission applicability**
- **TMS modularity provides opportunity for near-term reboost controlled reentry kits**
- **Staging TMS from orbiter permits significant discretionary payload increases to 160 nmi orbits**
- **TMS permits economical consideration of retrieval with STS**
- **TMS favorably influences escalating STS user charges**
- **Development/recurring costs for TMS could be 1/3 cost of alternatives**
- **TMS payoff resides in flexibility, servicing and reusability**

109

04 LN83 11181

AUTOMATED RENDEZVOUS AND PROXIMITY OPERATIONS
TECHNIQUES FOR RENDEZVOUS AND CLOSE-IN OPERATION
AND FOR SATELLITE SERVICING

ROBERT W. BECKER
JOHNSON SPACE CENTER

AND

ROBERT L. ANDERSON
LINCOM CORPORATION
18100 UPPER BAY ROAD
HOUSTON, TX 77058

INTRODUCTION

- o BACKGROUND
- o TEN YEAR TRAFFIC MODEL
- o REFERENCE TARGET VEHICLES REQUIREMENTS
- o ACTIVE VEHICLES
- o SOFT DOCKING SYSTEM
- o NAVIGATION SENSORS
- o G C SENSORS
- o AUTOMATED CONTROL TECHNIQUES
- o AUTOMATED SCENARIOS AND SOFTWARE OPS MODES
- o AUTOMATED PROXIMITY OPERATIONS TIMELINE EXAMPLE

BACKGROUND

"DEVELOPMENT OF AUTOMATED RENDEZVOUS AND PROXIMITY
OPERATIONS TECHNIQUES FOR RENDEZVOUS AND CLOSE-IN
OPERATIONS AND SATELLITE SERVICING"

TYPE: RTOP

OBJECTIVES: TO DEVELOP FREEFLYER AND ORBITER FLIGHT PROFILES
AND RECOMMEND HARDWARE/SOFTWARE REQUIREMENTS
THAT WILL PROVIDE AN AUTOMATED RENDEZVOUS,
STATION KEEPING, AND DOCKING CAPABILITY

TEN YEAR TRAFFIC MODEL

- A SURVEY OF THE MOST LIKELY RENDEZVOUS TARGETS WAS CONDUCTED USING GRUMMAN'S "SATELLITE AND SERVICES USER MODEL."
- INPUT DATA FOR DEVELOPING THE SATELLITE USER MODEL INCLUDED:
 - NASA 5 YEAR PLAN (1981 - 1985)
 - STS FLIGHT ASSIGNMENT BASELINE
 - BATTELLE LOW ENERGY MISSION MODEL
 - FUTURE PLANNING DOCUMENTS (LSTA, OSS, ETC)
 - OAST SPACE SYSTEMS TECHNOLOGY MODEL
 - DOD MISSION CATALOG
 - NORAD SPACECRAFT IDENTIFICATION LISTING
- ALTHOUGH THE MODEL CONTAINS 4 CLASSES OF SATELLITES, ONLY 2 CLASSES WERE USED IN LINCOM'S SURVEY:
 - 1) APPROVED AND FUNDED VEHICLES (A)
 - 2) VEHICLES PLANNED FOR START IN NEXT 5 YEARS (P)

RENDEZVOUS CALENDAR
(FUNDED AND APPROVED SATELLITES)
(DOD SATELLITES NOT INCLUDED)

1983	1984	1985	1986	1987
SPAS P-114	*(CHEM REL MOD)	SPAS LDEF ST	*LANDSAT D* *(CHEM REL MOD) *(ERBS) *(NOAA) ST	(SPAS) *EUVE *(COBE) ST (LDEF) *(NOSS)
1988	1989	1990	1991	1992
LDEF *(NOSS) ST *(NOSS)	(SPAS) ST *(NOSS) *(ERBS)	(LDEF) *(NOSS)	(SPAS) *(ERBS) (ST) (LDEF) *(NOSS)	LDEF. *(NOSS) (ST)

SCHEDULED EVENTS FROM 1983 THROUGH 1992
FUNDED AND APPROVED MISSIONS

	DEPLOY MISSIONS		SERVICE MISSIONS		RETRIEVAL MISSIONS	
	USER IDENTIFIED	ASSUMED	USER IDENTIFIED	ASSUMED	USER IDENTIFIED	ASSUMED
ORBITER ALONE	2	3	--	--	2	3
ORBITER + OMS KIT(S)	4	1	4	5	4	--
ORBITER + LEO PROP PACKAGE	8	6	--	5	2	9

OF ALL THE "APPROVED" USER IDENTIFIED RENDEZVOUS' (SERVICE OR RETRIEVAL EVENTS) SCHEDULED FOR THE NEXT TEN YEARS:

- 2 (17%) CAN BE PERFORMED BY AN ORBITER WITH INTEGRAL OMS PERFORMANCE
- 8 (67%) CAN BE PERFORMED BY AN ORBITER WITH OMS KITS
- 2 (17%) MUST BE PERFORMED VIA LEO PROPULSION PACKAGES

115

ORIGINAL PAGE IS
OF POOR QUALITY

RENDEZVOUS CALENDAR

(SATELLITES PLANNED BY PROGRAM OFFICE FOR START IN NEXT 5 YEARS)

(DOD SATELLITES NOT INCLUDED)

1983	1984	1985	1986	1987
*SOLAR MAX			*LANDSAT D" SUBSAT FAC	SUBSAT FAC *(MAGSAT) SASP PWR MOD *LANDSAT D" *(XRAY TIME) *(ICE/CLIM EXP)
1988	1989	1990	1991	1992
SASP PWR MOD AXRA GRAV PROB (COASTAL SAT) *(NOAA) *(H2O DUAL) *UPPER ATMOS *(HI ENGY) *(LANDOPS) SUBSAT FAC *LANDSAT D" *XRAY TIME *(ICE/CLIM EXP)	SASP PWR MOD (MAG FIELD SURV) AXRA GRAV PROB (COASTAL SAT) *(NOAA) *UPPER ATMOS *(LANDOPS) *(AWMW) *(EARTH SURV) SUBSAT FAC *LANDSAT D" *(LANDOPS)	SASP PWR MOD (MAG FIELD SURV) (COASTAL SAT) *UARS *(XRAY TIME) *(ICE/CLIM EXP) *(LANDOPS) *(PER) *(ADV THERM) SUBSAT FAC AXRA GRAV PROB *(NOAA) *(H2O DUAL) *(HI ENGY) *(LANDOPS) *(TOPOG EXP)	SASP PWR MOD (COASTAL SAT) *UARS *(ICE/CLIM EXP) *(EARTH SURV) *(OP MET) PWR MOD (MAG FIELD SURV) SUBSAT FAC *(NOAA) *(XRAY TIME) *(LANDOPS) *(AWMW)	SASP PWR MOD AXRA *UARS *(LANDOPS) *(ADV THERM) (COASTAL SAT) *(ICE/CLIM EXP) *(PER)

116

ORIGINAL PAGE IS
OF POOR QUALITY

LinCom

SCHEDULED EVENTS FOR 1983 THROUGH 1992
(SATELLITES DESIGNATED BY PROGRAM OFFICE FOR START IN NEXT 5 YEARS)

	DEPLOY MISSIONS		SERVICE MISSIONS		RETRIEVAL MISSIONS	
	USER IDENTIFIED	ASSUMED	USER IDENTIFIED	ASSUMED	USER IDENTIFIED	ASSUMED
ORBITER ALONE	16	6	9	3	6	2
ORBITER + OMS KIT(S)	2	1	14	4	3	--
ORBITER + LEO DROP PACKAGE	26	10	9	22	3	14

OF ALL THE "PLANNED" USER IDENTIFIED RENDEZVOUS' (SERVICE OR RETRIEVAL EVENTS) SCHEDULED FOR THE NEXT TEN YEARS:

- 15 (34%) CAN BE PERFORMED BY AN ORBITER WITH INTEGRAL OMS PERFORMANCE
- 17 (39%) CAN BE PERFORMED BY AN ORBITER WITH OMS KITS
- 12 (27%) MUST BE PERFORMED VIA LEO PROPULSION PACKAGES

LinCom

117

ORIGINAL PAGE IS
OF POOR QUALITY

RENDEZVOUS TRAFFIC
SUMMARY TABLE

YEAR	FUNDED OR APPROVED	PLANNED	TOTAL	LEO PROPULSION
1983	1	1	2	1
1984	1	1	2	2
1985	3	-	3	-
1986	5	2	7	5
1987	6	7	13	7
1988	4	14	18	10
1989	4	14	18	9
1990	2	19	21	13
1991	5	15	20	11
1992	3	10	13	7
TOTAL	34	83	117	65

TARGET VEHICLE REQUIREMENTS

- REPRESENTS A LARGE CLASS OF SIMILAR TARGET VEHICLES
- ACTIVE ATTITUDE CONTROL SYSTEM
- PASSIVELY COOPERATIVE
 - REQUIRED RETRIEVAL COMPONENTS IMPLEMENTED PRIOR TO LAUNCH
 - RETRIEVAL COMPONENTS ARE EXTERNAL TO SATELLITE SYSTEMS
 - RETRIEVAL COMPONENTS REQUIRE ONLY A PHYSICAL ATTACH POINT
- FIRM RENDEZVOUS REQUIREMENT

TARGET VEHICLES SELECTED

- LEO - LANDSAT/MMS
- HEO - GPS (NO RENDEZVOUS REQUIREMENT)
- GEO - TDRSS (NO RENDEZVOUS REQUIREMENT)

ACTIVE VEHICLES

- TELEOPERATOR MANEUVERING SYSTEM (TMS)/VOUGHT
- ORBITAL TRANSFER VEHICLE (OTV)/BOEING/GENERAL DYNAMICS
- MANNED ORBITAL TRANSFER VEHICLE (MOTV)/GRUMMAN
- MANEUVERABLE TELEVISION SYSTEM (MTV)/JSC/LOCKHEED
- SPACE PLANE/USAF/SRI

ORIGINAL PAGE IS
OF POOR QUALITY

SOFT DOCKING SYSTEM

- A "SOFT DOCKING" SYSTEM IS REQUIRED FOR DOCKING OPERATIONS
- A "SOFT DOCKING" SYSTEM REQUIRES ZERO VELOCITY TO EFFECT CAPTURE
- THE RMS SNARE TYPE END EFFECTOR IS AN EXAMPLE OF A LIGHT WEIGHT SOFT DOCKING SYSTEM
- THE SOFT DOCKING SYSTEM WILL "DRIVE" THE DOCKING SENSOR REQUIREMENTS
- A PRELIMINARY SET OF SOFT DOCKING SYSTEM REQUIREMENTS WERE GENERATED BY JIM JONES/JSC/EW4 AND EARL CRUM/JSC/EW4 IN SUPPORT OF THIS STUDY

ONBOARD GN&C SENSOR REQUIREMENTS

<div style="text-align: center;">SENSOR PARAMETER</div> <div style="text-align: left;">PHASE</div>	INERTIAL ATT	LVLH ATT	REL ATT	RELATIVE POSITION
Rendezvous	X	X		
Long-range Stationkeeping		X		X
\bar{V} Approach to 300'		X		X
\bar{V} Sk, at 300		X		X
Inertial Sk at 300'	X			X
Flyaround	X	X		X
Inspection			X	X
Docking			X	X

122

ORIGINAL PAGE IS
OF POOR QUALITY

ORIGINAL PAGE IS
OF POOR QUALITY

G&C SENSORS

• ACCELEROMETERS

• GYROS

- WHEELS

- LASERS - A LASER IRU THEORETICALLY OFFERS
SEVERAL ADVANTAGES OVER A STANDARD
STRAP-DOWN OR GIMBALED PLATFORM IRU:

1) SUPERIOR RELIABILITY

2) NO MOVING PARTS

3) LOWER UNIT COST

4) LEAST OPERATIONALLY COMPLEX

AUTOMATED CLOSE-IN CONTROL TECHNIQUE

ROTATION - ROTATION DAP - RCS

TRANSLATION - TRANSLATION DAP - RCS

ROTATION ALWAYS LEADS TRANSLATION

EXAMPLES

- ∇ STATIONKEEPING
- FLYAROUND
- FINAL APPROACH

▽ STATIONKEEPING

AV ATTITUDE CONTROL SYSTEM IS TRACKING LVLH FRAME SUCH THAT XBODY IS POINTED ALONG \bar{V}_{AV} AND YBODY IS POINTED ALONG \bar{H}_{AV} .

AV TRANSLATION CONTROL SYSTEM IS MAINTAINING ELEVATION, AZIMUTH ERROR ANGLES AND RANGE TO TARGET VEHICLE CORNER REFLECTOR WITHIN SPECIFIED LIMITS.

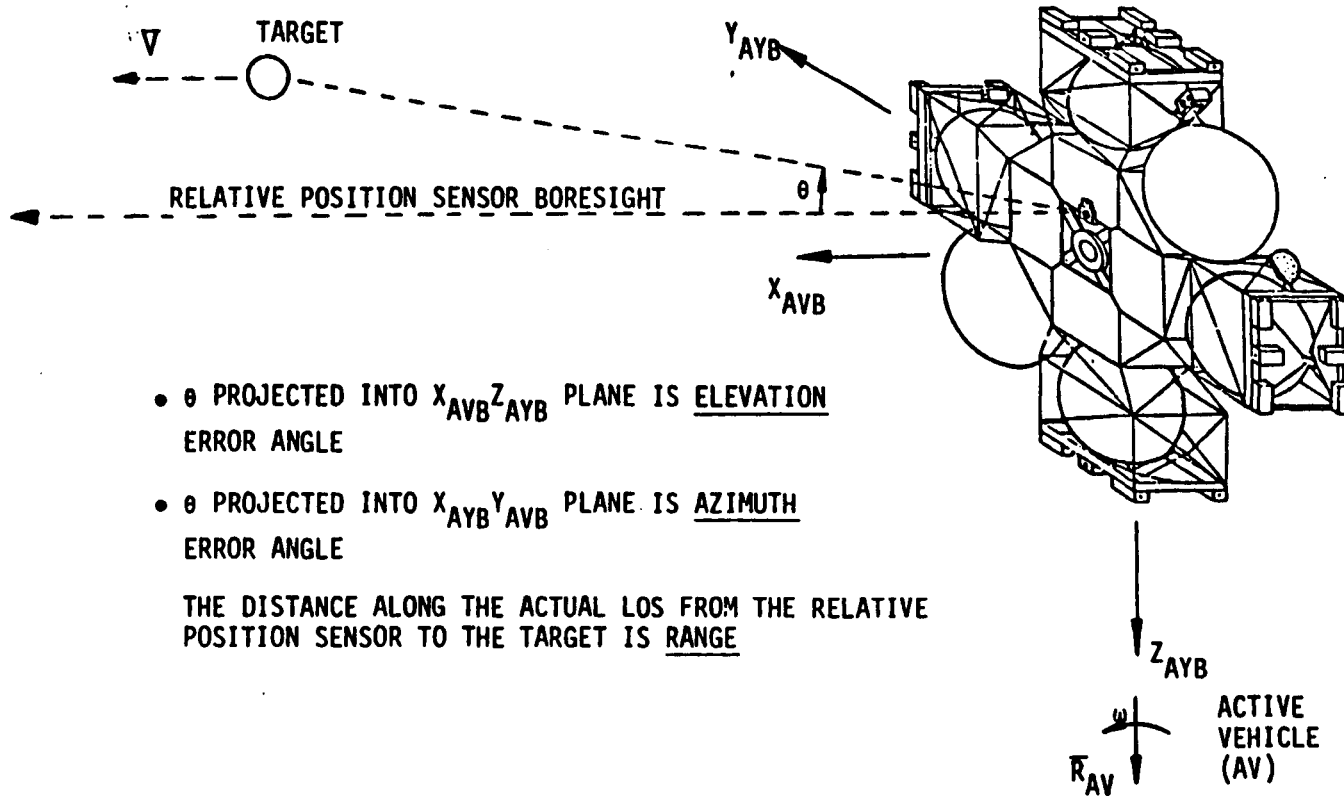

ORIGINAL PAGE IS
OF POOR QUALITY

- θ PROJECTED INTO $X_{AVB}Z_{AYB}$ PLANE IS ELEVATION ERROR ANGLE
- θ PROJECTED INTO $X_{AYB}Y_{AVB}$ PLANE IS AZIMUTH ERROR ANGLE

THE DISTANCE ALONG THE ACTUAL LOS FROM THE RELATIVE POSITION SENSOR TO THE TARGET IS RANGE

125

AUTOMATED SCENARIOS

- REFERENCE MISSIONS

- DELIVERY
- RETRIEVAL
- SERVICING
- REMOVAL
- TRANSFER

- COMMON OPERATIONS - COMMON OPERATIONS CAN BE USED TO CONSTRUCT THE TOTAL SET OF RENDEZVOUS OPERATIONS AND CAN BE THOUGHT OF AS OPERATIONAL SEQUENCES. EACH OPERATIONAL SEQUENCE CONTAINS THE NECESSARY SET OF MAJOR MODES AND FUNCTIONS TO ACCOMPLISH THE REQUIRED OPERATION.

- RNDZ MANEUVER TARGETING
- MANEUVER EXECUTE
- COAST
- BRAKING
- STATION KEEPING
- FLYAROUND
- FINAL APPROACH
- DOCKING
- SEPARATION

ORIGINAL PAGE IS
OF POOR QUALITY

SOFTWARE OPS MODES

- COMMON OPERATIONS ORIGINALLY CONCEIVED IN THE DEVELOPMENT OF AUTOMATED RENDEZVOUS SCENARIOS HAVE BEEN ORGANIZED INTO "OPS MODES" AND FURTHER SUBDIVIDED INTO MAJOR MODES."

OPS MODE	1XXX	SEQUENCER ACTIVE
OPS MODE	0XXX	TERMINATE SEQUENCER BUT CONTINUE WITH CURRENT MM (MAY BE USED WITH OPS MODES 400, 700, OR, 900)
OPS MODE	200	RENDEZVOUS (RUNS CONCURRENTLY WITH OPS MODES 400 OR 800)
	MM 201	ORBIT TARGET (LAMBERT OR CW)
	MM 202	MNVR EXEC (LAMBERT OR EXTERNAL ΔV)
OPS MODE	300	BRAKING
	MM 301	TO STANDOFF - DRIVES $\dot{e}, \dot{a}, \dot{r}$, TO ZERO AT $e = 0$
	MM 302	INERTIAL LOS TO TARGET - (ALWAYS ALONG FIXED LOS)
	MM 303	LVLH LOS TO TARGET - (ALWAYS ALONG FIXED LOS)
OPS MODE	400	STATIONKEEPING
	MM 401	INERTIAL
	MM 402	LVLH
	MM 403	LVLH/REL NAV
	MM 404	RELATIVE
	MM 405	SUB ORBIT
	MM 406	SUB ORBIT/REL NAV
OPS MODE	500	FINAL APPROACH/SEPARATION
	MM 501	FINAL APPROACH/SEPARATION
OPS MODE	600	FLYAROUND
	MM 601	INERTIAL
	MM 602	LVLH
	MM 603	CONSTANT RATE
OPS MODE	700	DOCKING
	MM 701	APPROACH
	MM 702	SEPARATION
OPS MODE	800	COAST
	MM 801	INERTIAL ATTITUDE HOLD
	MM 802	LVLH ATTITUDE HOLD
	MM 803	INERTIAL MANEUVER
	MM 804	LVLH MANEUVER
	MM 805	TARGET TRACK
	MM 806	TARGET TRACK/REL NAV
	MM 807	ROTATION
	MM 808	FREE DRIFT

ORIGINAL PAGE IS
OF POOR QUALITY

A "SEQUENCER" IS REQUIRED TO:

- 1) PERFORM PREPLANNED SEQUENCE OF MAJOR MODE TRANSITIONS
- 2) ENSURE PROPER DATA TRANSFER AND INITIALIZATION BETWEEN MAJOR MODE TRANSITIONS
- 3) ASSEMBLE NECESSARY HARDWARE/SOFTWARE SYSTEMS
- 4) PROVIDE FOR THE MAN/MACHINE INTERFACE

SOME SOFTWARE NOTES . . .

- ANY GIVEN MISSION WOULD CONSIST OF A SUBSET OF THE ABOVE MAJOR MODES
- ALL CURRENT AND CONCEIVED RENDEZVOUS/PROX OPS MISSIONS CAN BE PERFORMED WITH THE PROPER SEQUENCE OF THE LISTED MAJOR MODES.
- A LARGE PORTION OF THE SOFTWARE REQUIREMENTS FOR THE LISTED MAJOR MODES ALREADY EXIST IN THE LEVEL C GN&C ON-ORBIT GUIDANCE FSSR.
- SYSTEM DIAGRAMS FOR EACH MAJOR MODE HAVE BEEN GENERATED. THE SYSTEM DIAGRAMS SHOW THE REQUIRED SYSTEM COMPONENTS, THE BASIC SYSTEM REQUIREMENTS, AND THE DATA FLOW BETWEEN COMPONENTS.
- FOLLOWING IS A SELECTED SYSTEM DIAGRAM AS AN EXAMPLE.

MM1402 GNC SYSTEM LAYOUT

MM1402
LVLH
STATIONKEEPING

AUTONOMOUS RENDEZVOUS, PROXIMITY OPERATIONS, DOCKING

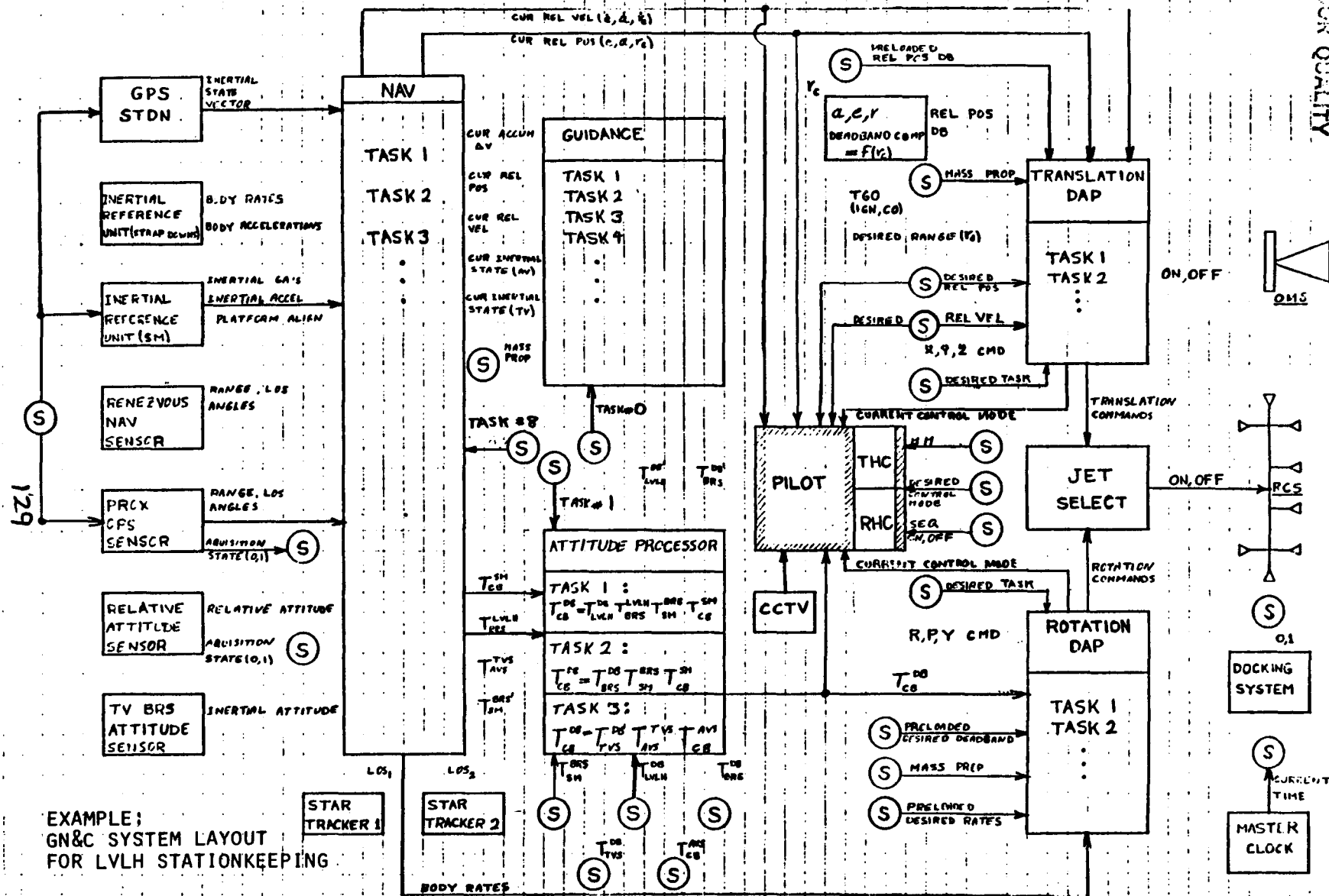

ORIGINAL PAGE IS
OF POOR QUALITY

EXAMPLE;
GN&C SYSTEM LAYOUT
FOR LVLH STATIONKEEPING

- RESULTS OF MAJOR MODES CONCEPT . . .
 - EASILY IDENTIFIES THE SPECIFIC ITEMS THAT NEED TO BE WORKED, BOTH HARDWARE AND SOTWARE, AS A FUNCTION OF MISSION PHASE.
 - PROVIDES OVERALL SYSTEM DEFINITION
 - SERVES AS A FRAMEWORK FOR ORGANIZING DETAILED SYSTEM REQUIREMENTS

TIMELINE EXAMPLE
AUTOMATED PROXIMITY OPERATIONS

LinCom

RELATIVE MOTION PLOT
FINAL APPROACH, FLYAROUND, DOCKING
LVLH TARGET VEHICLE

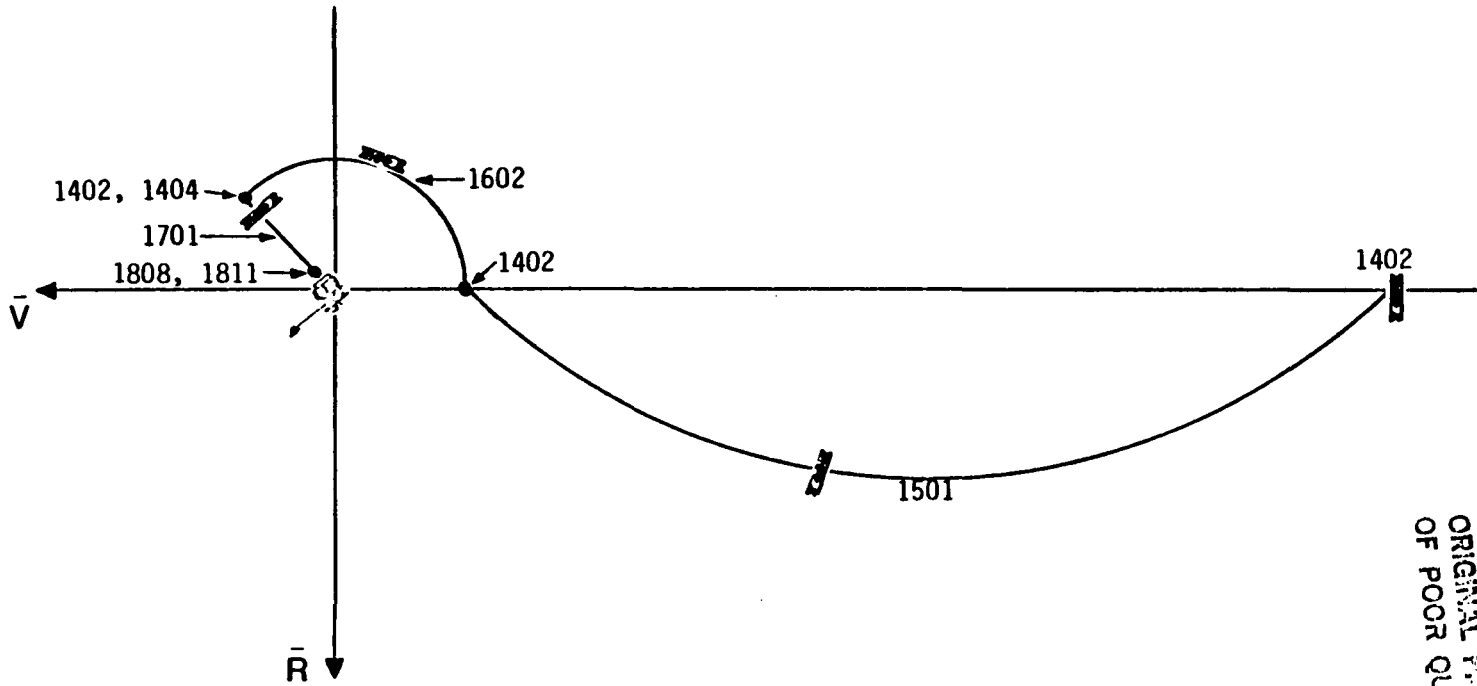

ORIGINAL PAGE IS
OF POOR QUALITY

LinCom

132

TIMELINE
AUTOMATED PROXIMITY OPERATIONS

AUTOMATED OPERATIONS					GROUND OPERATION
TIME	EVENT	MM	DESCRIPTION	CONDITION	
01:30	LVL H SK	1402	LVLH STATIONKEEPING (V)	COMPLETION OF TPF MANEUVER	
01:40	FINAL APP	1501	FINAL APPROACH INITIATION	MM1402 + 10 MIN.	
01:50					
02:00	LVLH SK	1402		LOCAL HORIZONTAL ELEVATION ANGLE GOES THROUGH 0°	

ORIGINAL PAGE IS
OF POOR QUALITY

TIMELINE
AUTOMATED PROXIMITY OPERATIONS

AUTOMATED OPERATIONS					GROUND OPERATION
TIME	EVENT	MM	DESCRIPTION	CONDITION	
02:00					
02:10	FLY ARND	1602	FLYAROUND TO DESIRED LVLH ATTITUDE	MM1402 + 10 MIN.	
	DOCKING SENSOR ACQ				
02:20	LVLH SK	1402	LVLH STATIONKEEPING	LVLH DOCKING ATTITUDE ACHIEVED	
	REL SK	1404		DOCKING SENSOR ACQ + (MM1402 + 2 MIN	
02:30	DOCKING	1701	DOCKING APPROACH	MM1404 + 5 MIN.	

134

ORIGINAL PAGE IS
OF POOR QUALITY

TIMELINE
AUTOMATED PROXIMITY OPERATIONS

AUTOMATED OPERATIONS					GROUND OPERATION
TIME	EVENT	MM	DESCRIPTION	CONDITION	
02:30	SOFT DOCK	1808	COAST (UNDOCKED FREE DRIFT)		
02:40	HARD DOCK	1811	COAST (DOCKED INERTIAL HOLD)		
02:50					ORIGINAL PAGE IS OF POOR QUALITY
03:00					

135

ORIGINAL PAGE IS
OF POOR QUALITY

CONCLUSIONS

- ALTHOUGH THE U.S. HAS NEVER PERFORMED AN AUTOMATED RENDEZVOUS AND DOCKING, MOST OF THE "PIECES" REQUIRED TO BUILD AN AUTOMATED SYSTEM CURRENTLY EXIST.

MAJOR EXCEPTIONS ARE:

- CLOSE IN REL ATT SENSOR SYSTEM
 - CLOSE IN REL POS SENSOR SYSTEM
 - TRANSLATION DAP SOFTWARE
 - SEQUENCER SOFTWARE
 - SOFT DOCKING SYSTEM
- AUTOMATED RENDEZVOUS TECHNIQUES AND OPERATIONS ARE GENERIC IN NATURE AND APPLICABLE TO MANNED AS WELL AS UNMANNED SYSTEMS

137

SOLAR MAXIMUM OBSERVATORY REPAIR MISSION

G. P. KENNEY
JOHNSON SPACE CENTER
JUNE 22, 1982

FN83 11182 27

SOLAR MAXIMUM OBSERVATORY REPAIR MISSION

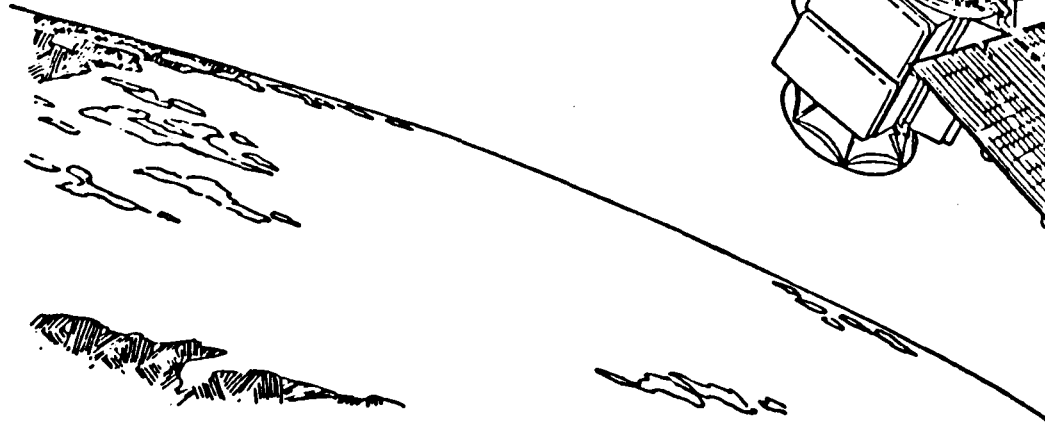
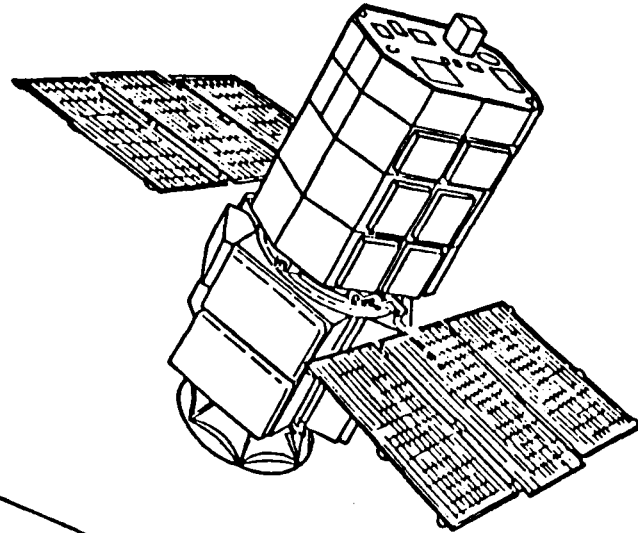
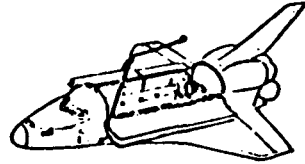

138

ORIGINAL PAGE IS
OF POOR QUALITY

SOLAR MAXIMUM REPAIR MISSION

RATIONALE

- THE SOLAR MAXIMUM SPACECRAFT IS THIS NATION'S ONLY ORBITING SOLAR OBSERVATORY.
 - SPACECRAFT PARTIALLY DISABLED -- 3 OF 7 SCIENTIFIC INSTRUMENTS CURRENTLY OPERATING.
 - IMPORTANT NEW SOLAR SCIENCE CAN BE DONE WITH SPACECRAFT REPAIR.
 - SHUTTLE MANIFESTING OPPORTUNITIES OCCUR IN LATE 1983 TO EARLY 1984.
 - SPACECRAFT AND SCIENCE REPAIR KITS CAN BE MADE AVAILABLE BY LATE 1983.
- ON-ORBIT SERVICING/RETRIEVAL IS A PLANNED AND IMPORTANT CAPABILITY UNIQUE TO THE SHUTTLE.
- SEVERAL IMPORTANT NASA PROGRAMS INCLUDE THIS CAPABILITY:
(E.G., LANDSAT, LONG DURATION EXPOSURE FACILITY, SPACE TELESCOPE, SOLAR MAXIMUM MISSION).
- TIMELY DEMONSTRATION IS NEEDED TO ENCOURAGE OTHER USERS TO INCORPORATE FUTURE SPACE REPAIR/RETRIEVAL COMPATIBILITY IN THEIR DESIGN SPECIFICATIONS.
- WOULD DRAMATICALLY DEMONSTRATE TO THE INTERNATIONAL COMMUNITY THE BENEFITS OF SHUTTLE OVER COMPETING LAUNCH SYSTEMS.
- MISSION HAS HIGH PUBLIC AND INDUSTRY APPEAL
 - NECESSARY FOR EFFECTIVE SPACE INDUSTRIALIZATION AND FUTURE MISSION PLANNING.

SOLAR MAXIMUM OBSERVATORY

DESCRIPTION

- THREE-AXIS STABILIZED SOLAR-POINTING OBSERVATORY
NO PROPULSION
- SEVEN SCIENTIFIC INSTRUMENTS TO INVESTIGATE SOLAR
FLARES AND ENERGY OUTPUT
- SPACECRAFT DESIGNED TO BE CAPTURED AND SERVICED IN
ORBIT OR RETRIEVED BY THE SHUTTLE

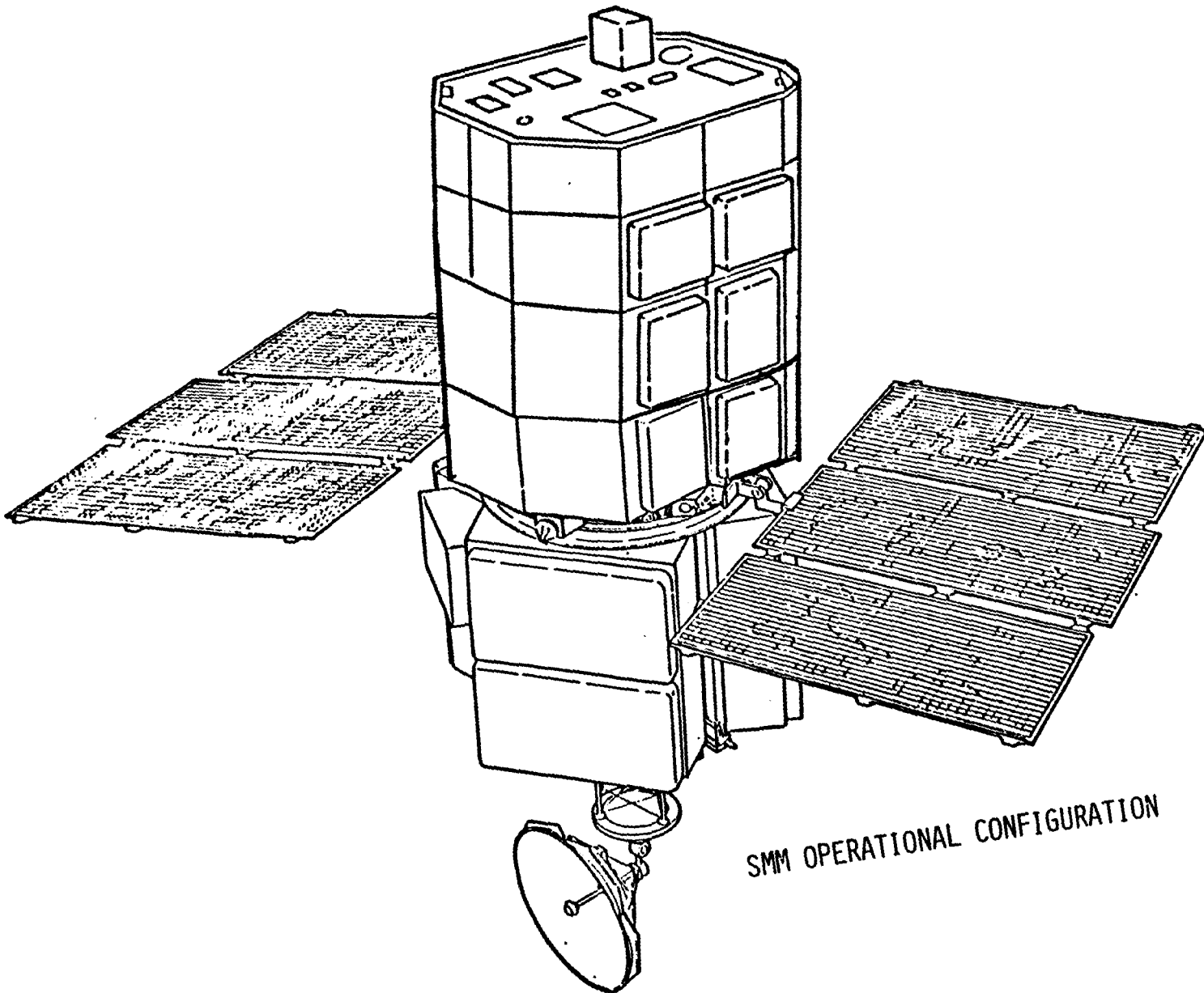

ORIGINAL PAGE IS
OF POOR QUALITY

SMM OPERATIONAL CONFIGURATION

141

ORIGINAL PAGE IS
OF POOR QUALITY

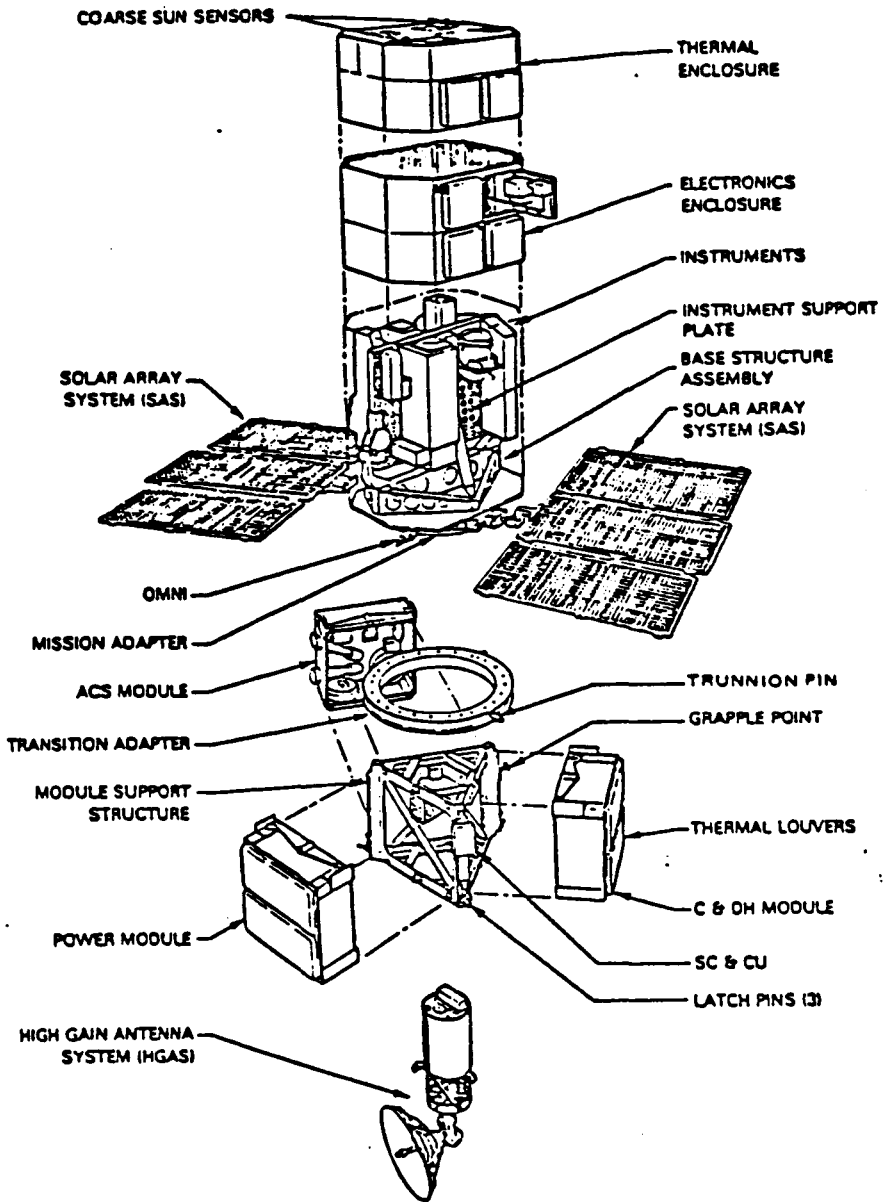

SMM OBSERVATORY EXPLODED VIEW

SOLAR MAXIMUM MISSION

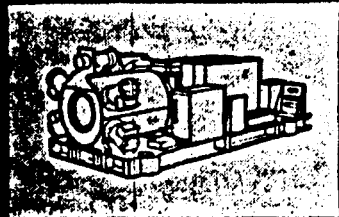

SOLAR CONSTANT SPECTROMETER

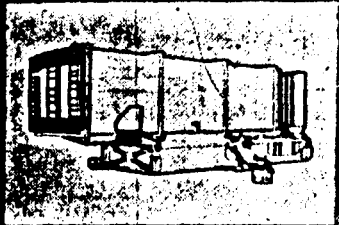

SOLAR CONSTANT SPECTROMETER

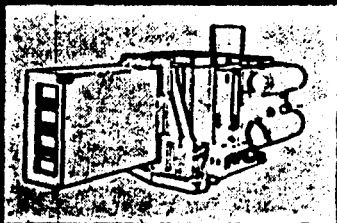

SOLAR CONSTANT SPECTROMETER

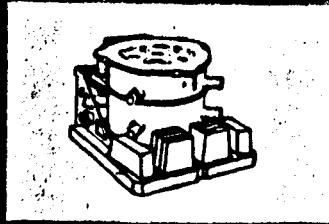

GAMMA RAY SPECTROMETER

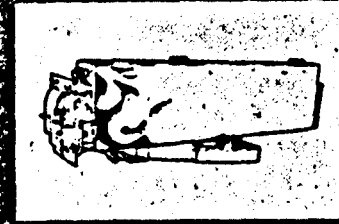
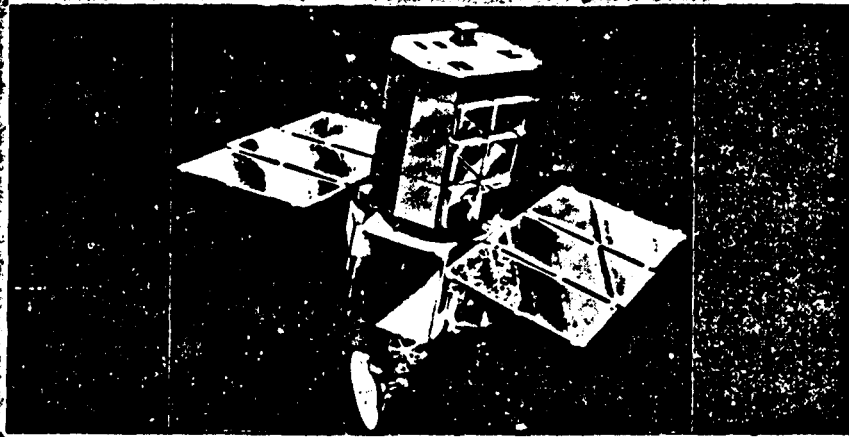

UV SPECTROMETER POLARIMETER

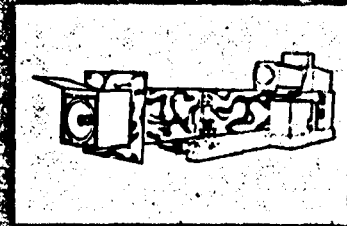

CORONAGRAPH POLARIMETER

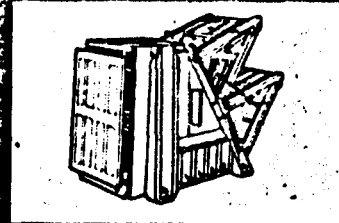

X-RAY POLYCHROMATOR BENT CRYSTAL SPECTROMETER

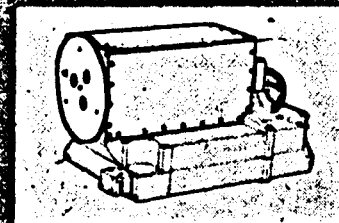

ACTIVE CAVITY RADIOMETER IRRADIANCE MONITOR

ORIGINAL PAGE IS OF POOR QUALITY

MAJOR SMM RESULTS TO DATE

- FIRST IMAGES EVER MADE OF HARD X-RAYS FROM A SOLAR FLARE
- DISCOVERY OF SOURCE OF HIGH-ENERGY EMISSIONS FROM FLARES
- DETECTION OF SHORT-TERM AND LONG-TERM VARIATIONS IN TOTAL SOLAR ENERGY OUTPUT
- DISCOVERY OF RAPID ACCELERATION OF PROTONS IN FLARES
- DISCOVERY OF MANY NEW NUCLEAR REACTIONS IN FLARES, SHOWING UNUSUAL ELEMENT ABUNDANCES
- DETECTION OF VIOLENT MOTIONS IN HIGH-TEMPERATURE FLARE PLASMA
- FIRST DETECTION OF NEUTRONS FROM A FLARE

WHAT SCIENCE CAN BE DONE WITH A REPAIRED
SOLAR MAXIMUM MISSION

MAJOR SCIENCE OBJECTIVES

1. SOLAR FLARE STUDIES WITH SIX COORDINATED INSTRUMENTS
2. MEASUREMENTS OF CHANGES IN TOTAL SOLAR ENERGY OUTPUT
3. STUDIES OF OSCILLATIONS OF THE SUN
4. EVOLUTION OF THE SOLAR CORONA
5. STUDIES OF THE QUIET SUN AND EARTH

SOLAR MAXIMUM OBSERVATORY

STATUS

- FUSE FAILURES IN ATTITUDE CONTROL SYSTEM MODULE WHEEL DRIVE CIRCUITS NEGATED THE OBSERVATORY'S FINE POINTING CAPABILITY (ARC SEC) DECEMBER, 1980
- SPACECRAFT UNDER COARSE-POINTING CONTROL MODE IS GATHERING SCIENTIFIC DATA (THREE OF SEVEN INSTRUMENTS). FOUR INSTRUMENTS REQUIRE FINE POINTING.
- SPACECRAFT REMAINS UNDER CONTROL THROUGH USE OF MAGNETIC TORQUER BARS AND SLOW ROLL: ROTATION IS ABOUT THE ROLL AXIS AT APPROXIMATELY $0.9^{\circ}/\text{SEC}$.
- ORBIT ALTITUDE AS OF 4/14/82 IS 285.0 N. MI. PREDICTED (8/30/81) TO BE 285 N. MI.
- ATTITUDE CONTROL SYSTEM MODULE AND SCIENTIFIC INSTRUMENTS REPAIRABLE VIA MANNED EVA.
- MINOR OPERATIONAL ANOMALIES ON TWO SCIENTIFIC INSTRUMENTS. ANOTHER INSTRUMENT HAS MALFUNCTION OF ITS ELECTRONICS MODULE.
- ALL OTHER SPACECRAFT SYSTEMS OPERATING SUCCESSFULLY AND WITH FULL REDUNDANCY.

146

ORIGINAL PAGE IS
OF POOR QUALITY

147

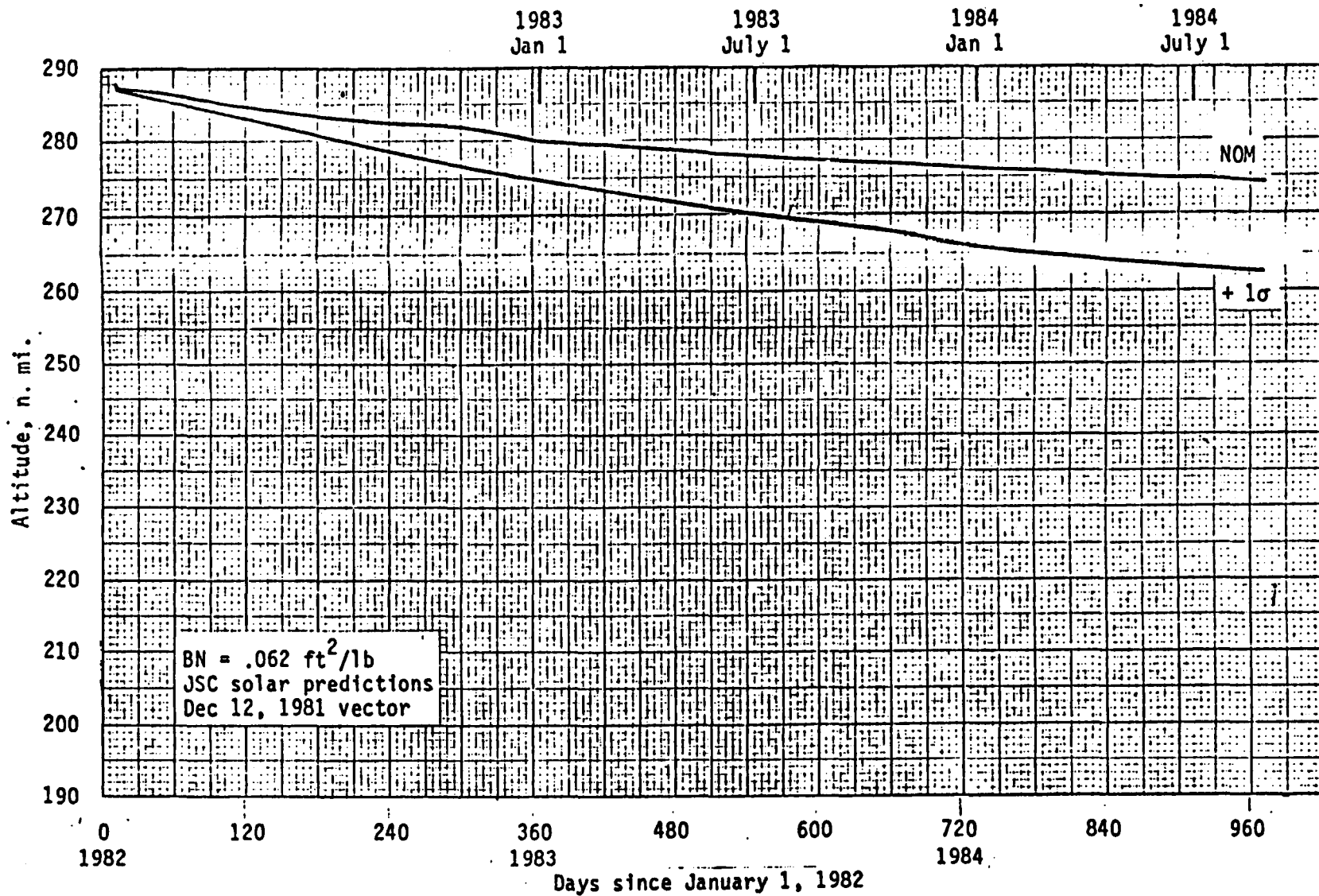

ORIGINAL PAGE IS
OF POOR QUALITY

SMM DECAY PREDICTIONS

HARDWARE ELEMENTS

SYSTEM CONFIGURATION

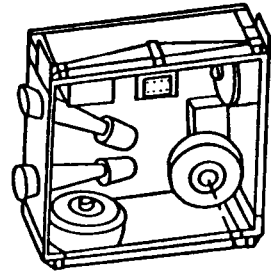

ATTITUDE CONTROL
MODULE

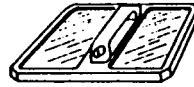

HXIS THERMAL
CLOSURE

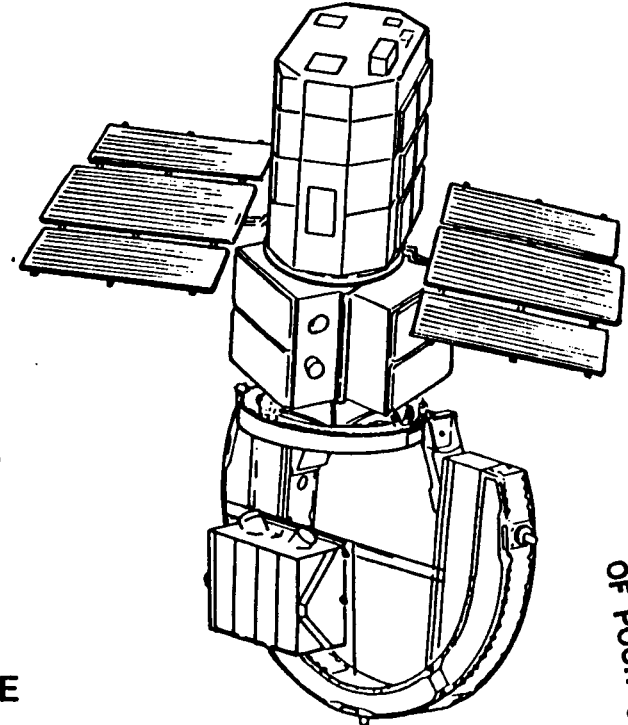

ORIGINAL PAGE IS
OF POOR QUALITY

148

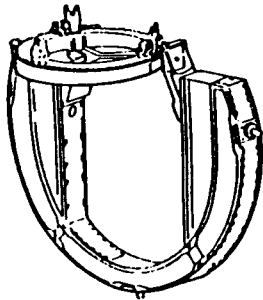

FSS CRADLE A'



XRP
BAFFLE

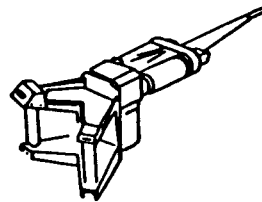

MODULE SERVICE
TOOL



C/P ELECTRONICS

SOLAR MAXIMUM MISSION

SOLAR MAXIMUM OBSERVATORY REPAIR MISSION CHARACTERISTICS

- SHUTTLE LAUNCH - 3/84
- SHUTTLE CONFIGURATION INCLUDES:
 - REMOTE MANIPULATOR SYSTEM (RMS)
 - FLIGHT SUPPORT SYSTEM (FSS)
 - MANNED MANEUVERING UNIT (MMU)
- SPACECRAFT REPAIR KIT - SPARE LANDSAT ACS MODULE
- SCIENTIFIC INSTRUMENT REPAIR KITS - CORONAGRAPH ELECTRONICS, X-RAY POLYCHROMATOR BAFFLE AND HARD X-RAY IMAGING SPECTROMETER THERMAL CLOSURE
- REPAIR ACCOMPLISHED BY:
 - CAPTURE AND CONTROL OF OBSERVATORY IN FREE-FLIGHT BY ASTRONAUT IN THE MANNED MANEUVERING UNIT
 - OBSERVATORY BERTHED TO THE ORBITER WITH THE SHUTTLE REMOTE MANIPULATOR SYSTEM
 - THE SMM SPACECRAFT ATTITUDE CONTROL SYSTEM IS REPLACED USING EVA
 - THE SCIENTIFIC INSTRUMENTS ARE REPAIRED USING EVA
- REPAIR MISSION WILL RESTORE FINE POINTING AND ALL SCIENTIFIC INSTRUMENTS TO FULL PERFORMANCE.

ORIGINAL PAGE IS
OF POOR QUALITY

150

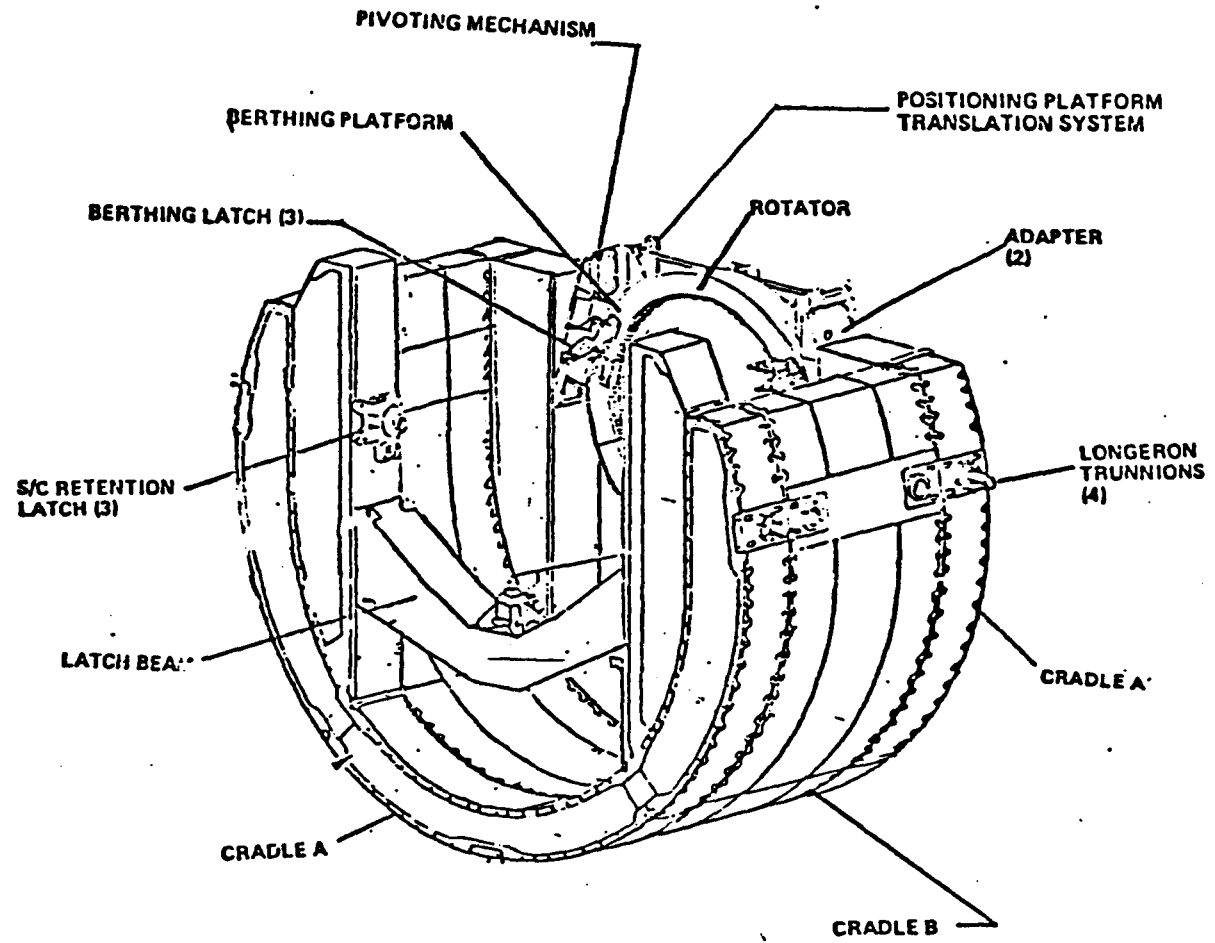

FSS STOWED CONFIGURATION FOR SMM RETRIEVAL

ORIGINAL PAGE IS
OF POOR QUALITY

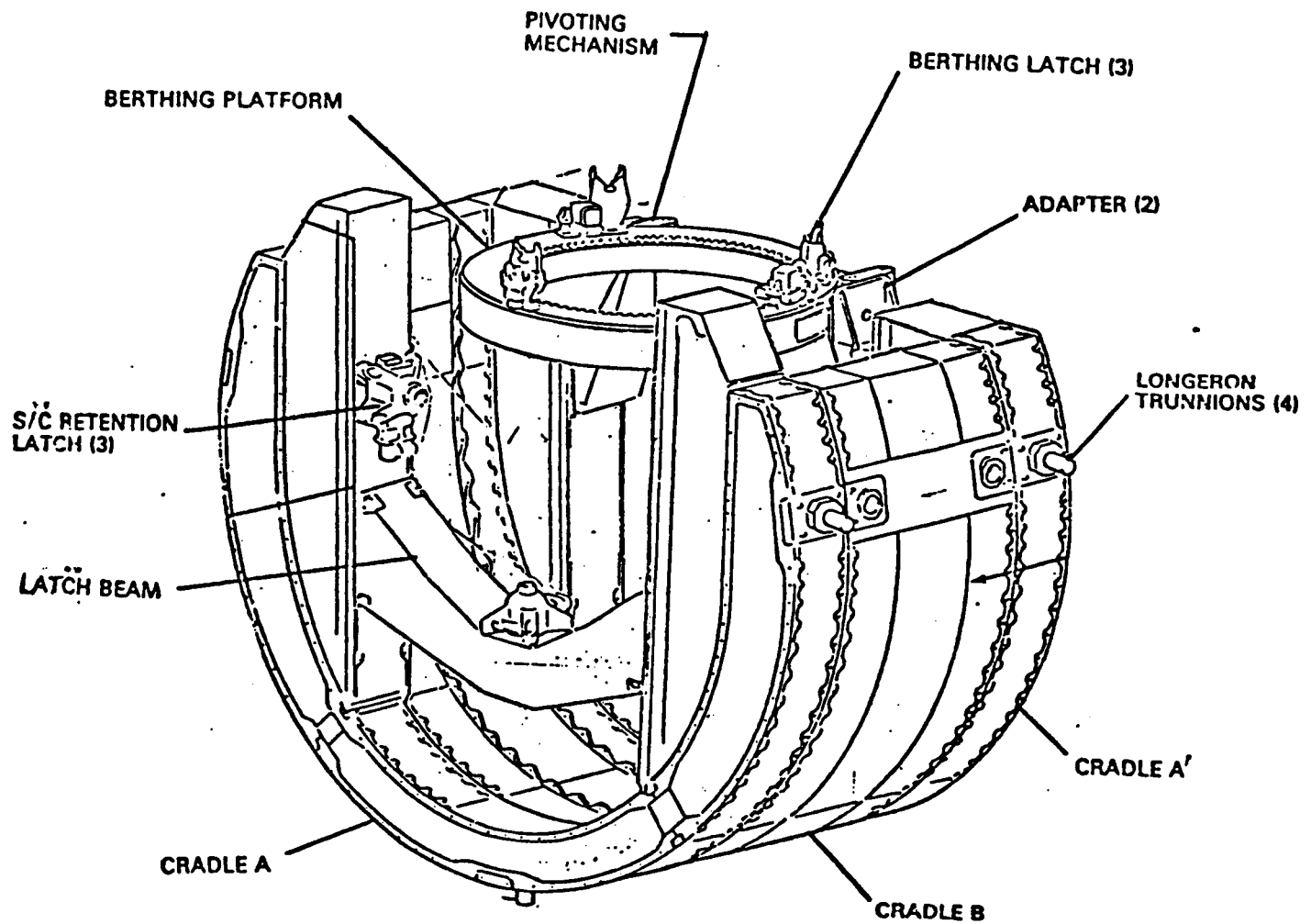

151

ORIGINAL PAGE IS
OF POOR QUALITY

FSS OPERATIONAL CONFIGURATION FOR SMM RETRIEVAL

SMM SPACECRAFT TUMBLE RATES

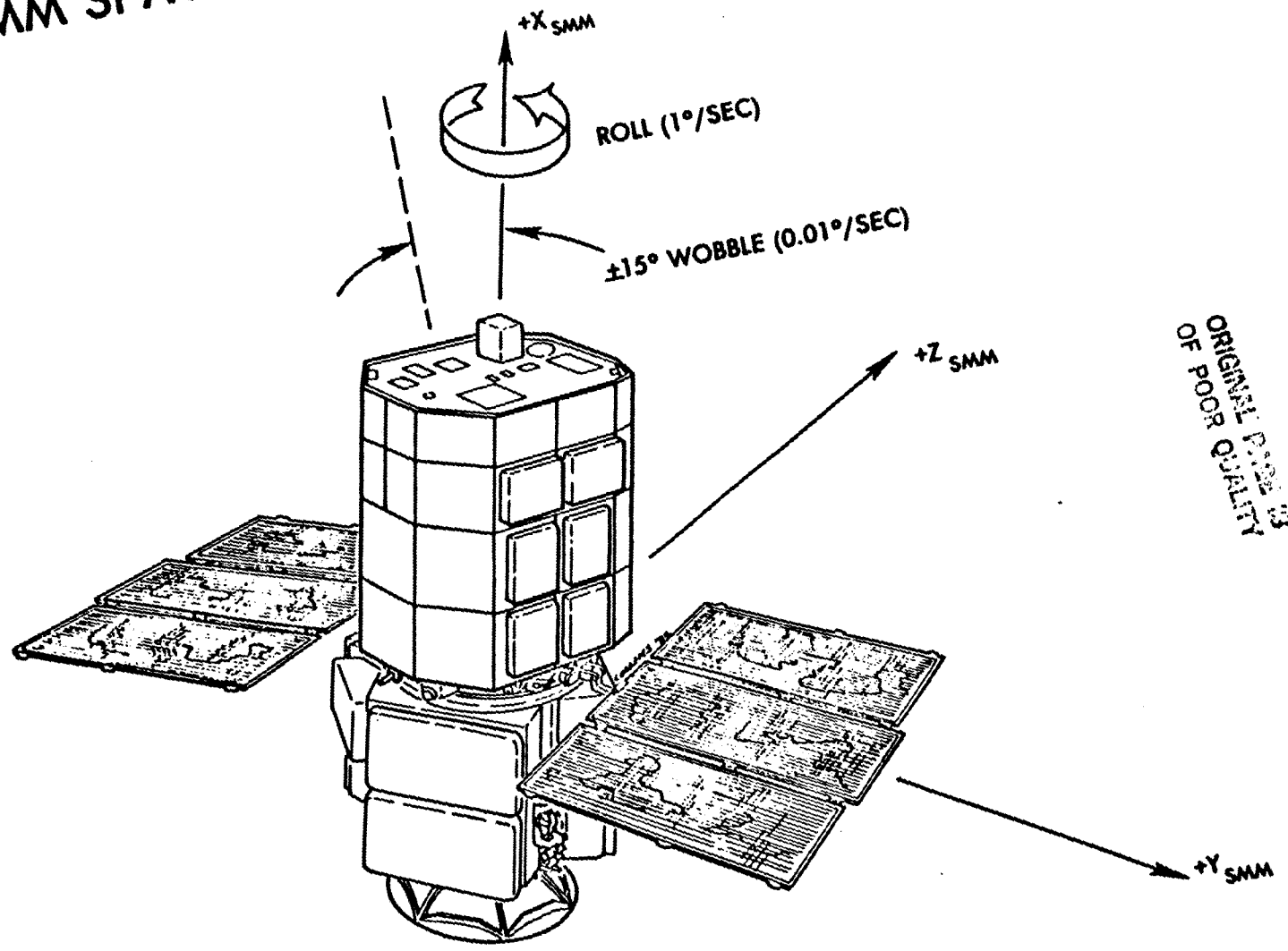

ORIGINAL PICTURE
OF POOR QUALITY

152

ORIGINAL PAGE 13
OF POOR QUALITY

MANNED MANEUVERING UNIT WITH TRUNNION PIN ATTACHMENT DEVICE

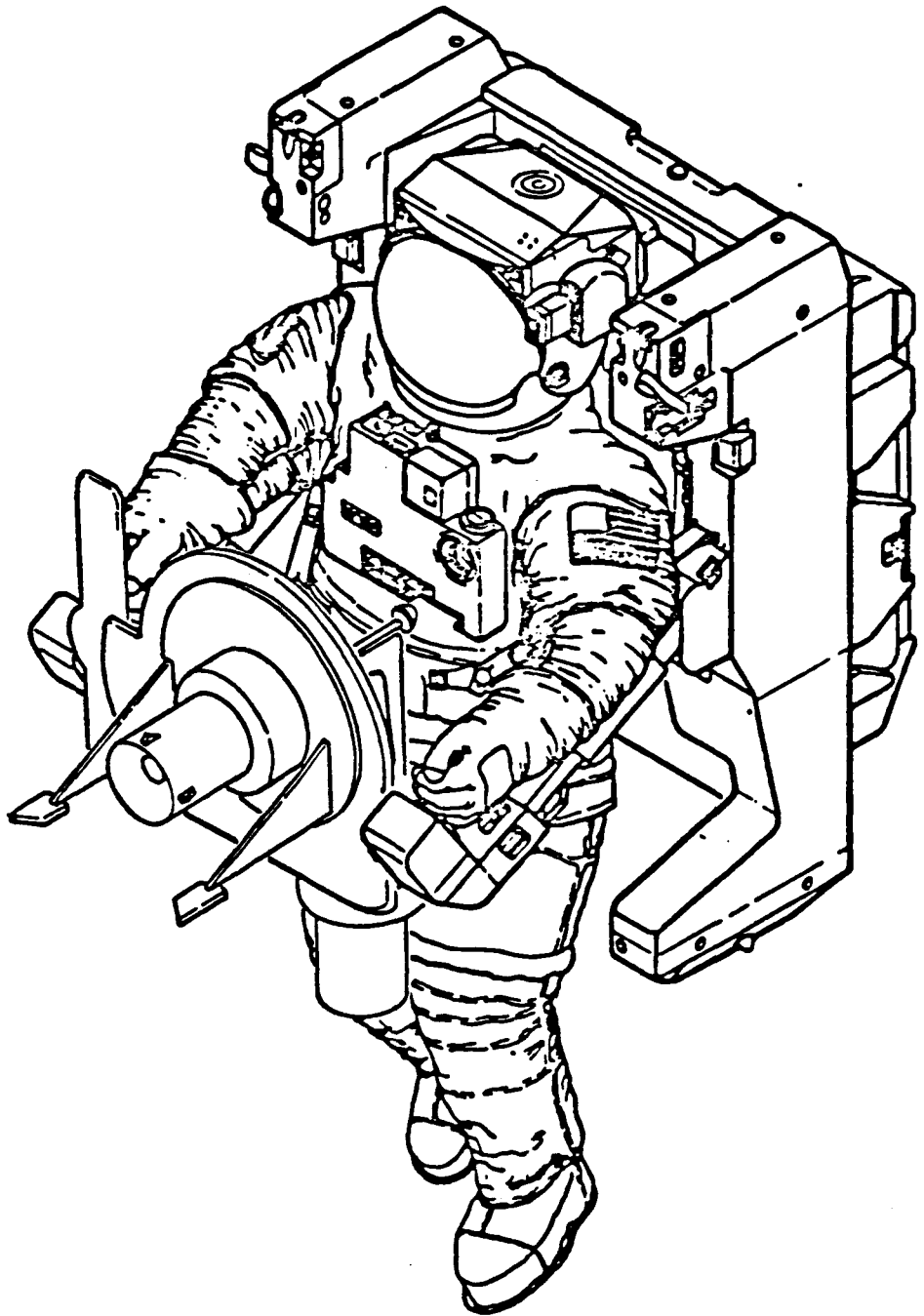

MMU CAPTURE OF SMM

- SHUTTLE STATIONKEEPS AT APPROXIMATELY 200 FEET
- EVA CREWMEMBER FLIES MMU OVER TO SMM SPACECRAFT CARRYING SECOND RMS GRAPPLE FIXTURE

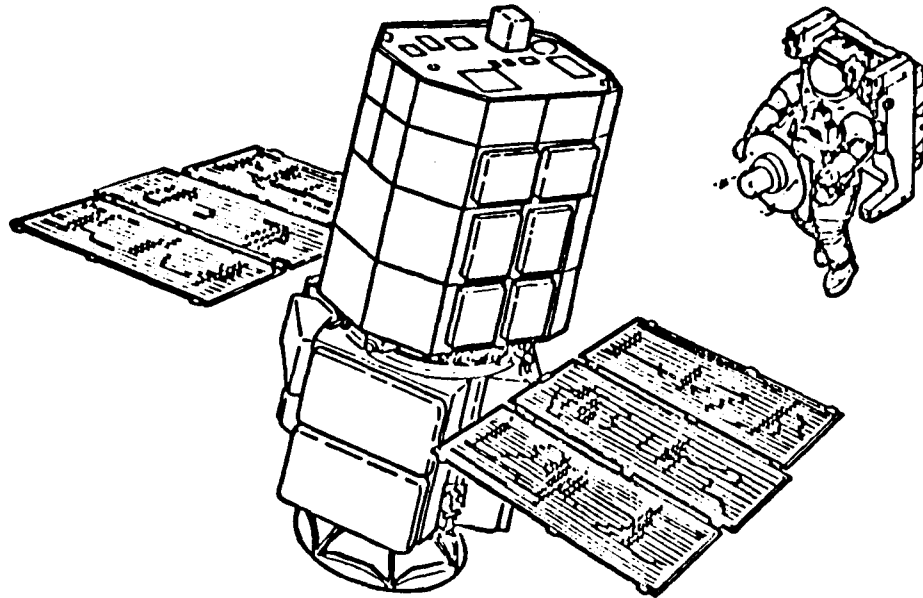
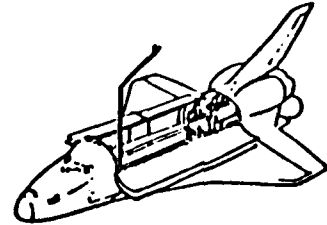

154

ORIGINAL PRICE IS
OF POOR QUALITY

MMU ATTACHING SECOND RMS GRAPPLE FIXTURE
AND STABILIZING SMM

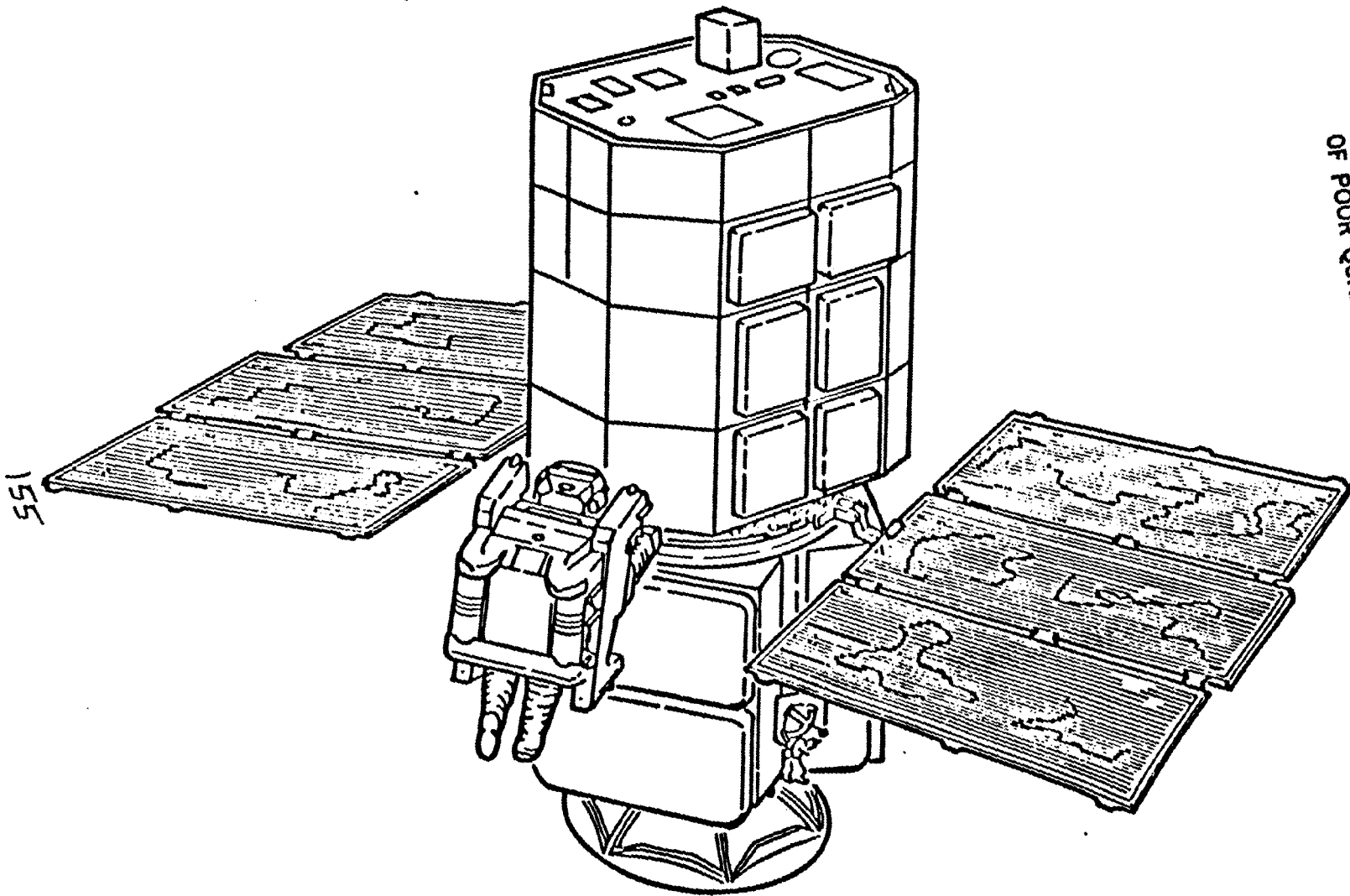

ORIGINAL PAGE IS
OF POOR QUALITY

MMU CAPTURE OF SMM (CONT'D)

- **EVA CREWMEMBER WITH MMU:**

- UNDOCKS FROM SMM LEAVING SECOND RMS GRAPPLE FIXTURE ON SMM TRUNNION PIN
- FLIES TO BACKSIDE OF SMM AND DOCKS TO OPPOSITE SMM TRUNNION PIN
- USES MMU THRUSTERS TO MAINTAIN SMM ATTITUDE DURING SHUTTLE APPROACH AND RMS GRAPPLING

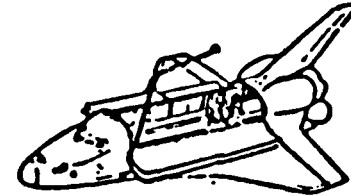
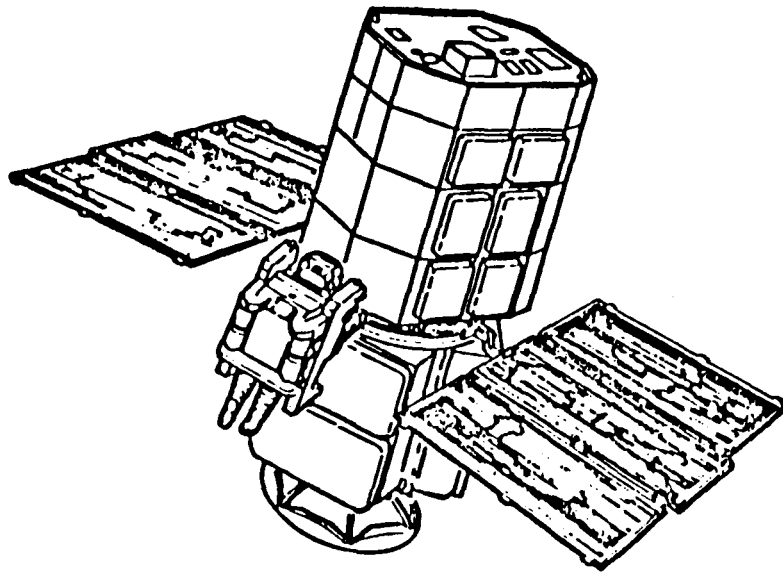

156

ORIGINAL PAGE IS
OF POOR QUALITY

SOLAR MAXIMUM MISSION SPACECRAFT
READY FOR RMS GRAPPLING

157

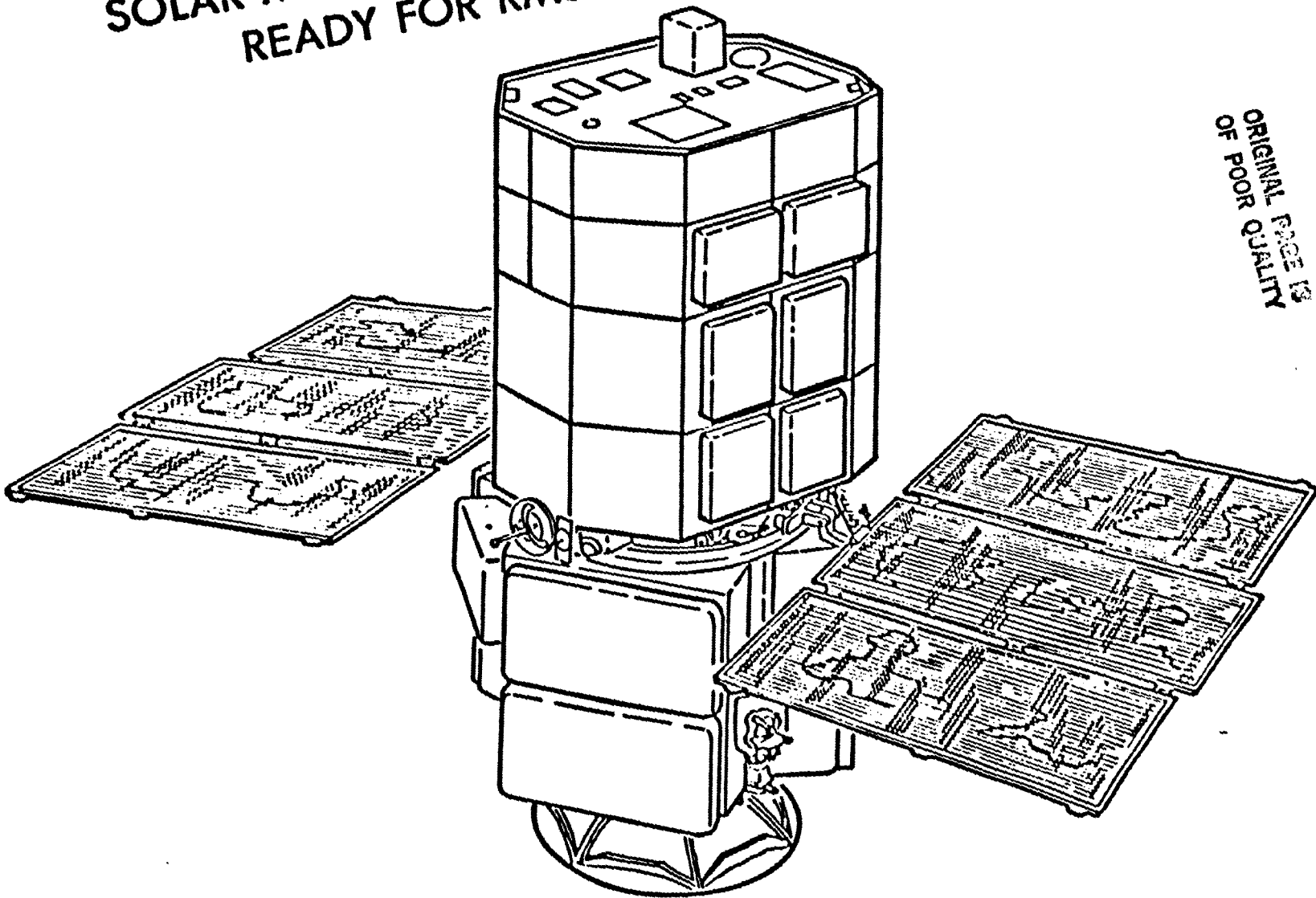

ORIGINAL PAGE IS
OF POOR QUALITY

MANNED MANEUVERING UNIT WITH
SMM ATTACHMENT DEVICE

ORIGINAL PAGE IS
OF POOR QUALITY

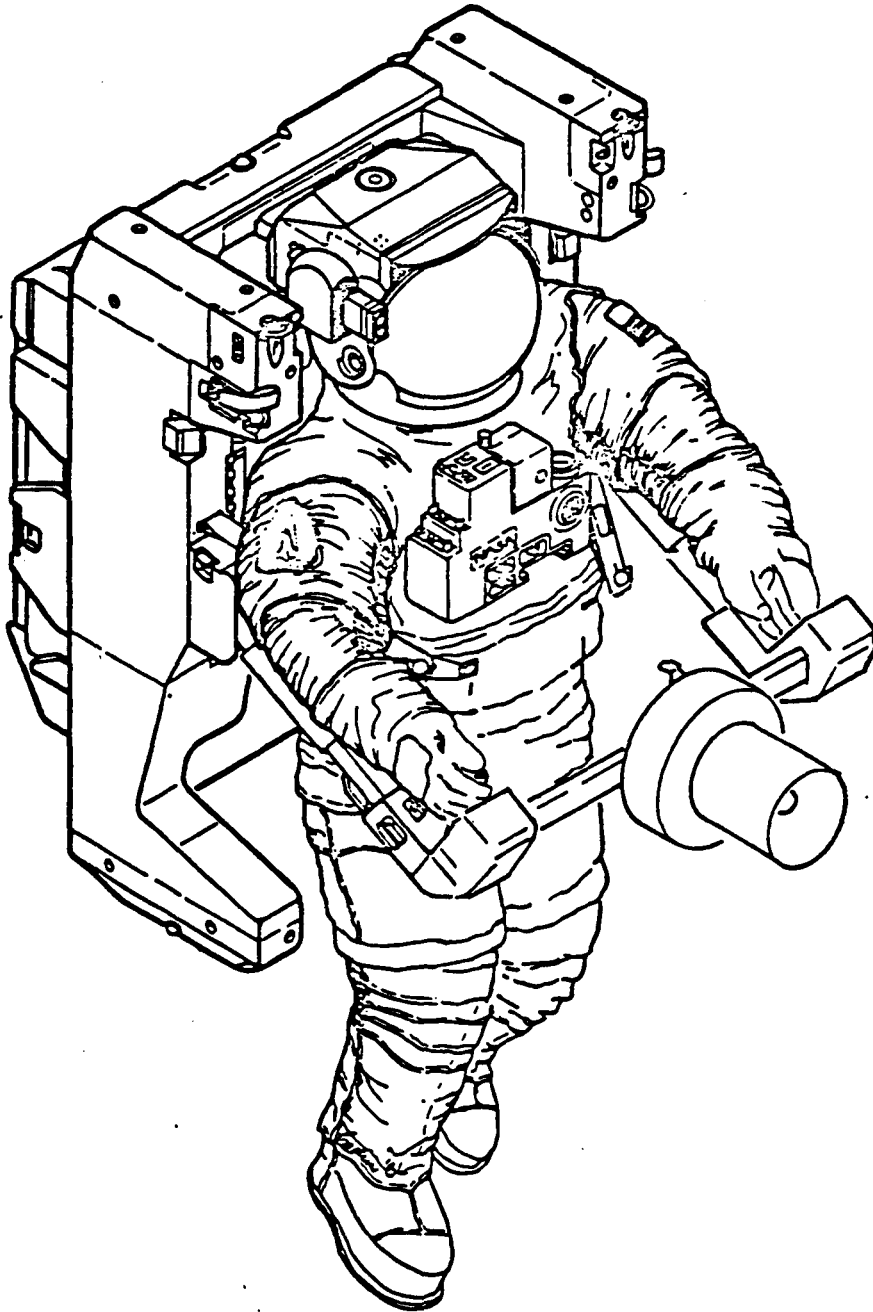

MMU CAPTURE OF SMM (CONT'D)

- RMS GRAPPLES SMM
- EVA CREWMEMBER WITH MMU:
 - UNDOCKS FROM SMM
 - COLLECTS CONTAMINATION SAMPLES
 - PHOTOGRAPHS SMM AND BERTHING OPERATIONS
 - RETURNS TO PAYLOAD BAY AND DOFFS MMU
- RMS BERTHS SMM TO CRADLE

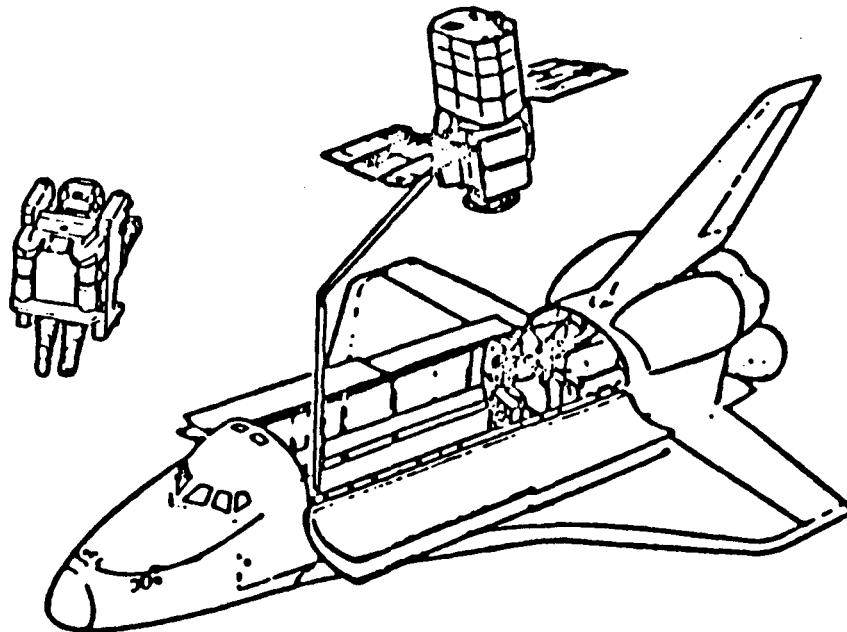

ORIGINAL PAGE IS
OF POOR QUALITY

MMU CAPTURE OF SMM (CONT'D)

- EVA CREWMEMBERS CHANGE OUT SMM ATTITUDE CONTROL MODULE AND REPAIR MAIN ELECTRONICS BOX
- RMS DEPLOYS SMM
- CONTINGENCY MMU SUPPORT:
 - INSTALL THERMAL BARRIER OVER HARD X-RAY SPECTROMETER WINDOW
 - INSTALL PLASMA SHIELD OVER X-RAY POLYCHROMETER VENT
 - RESTABILIZE SMM AFTER DEPLOYMENT

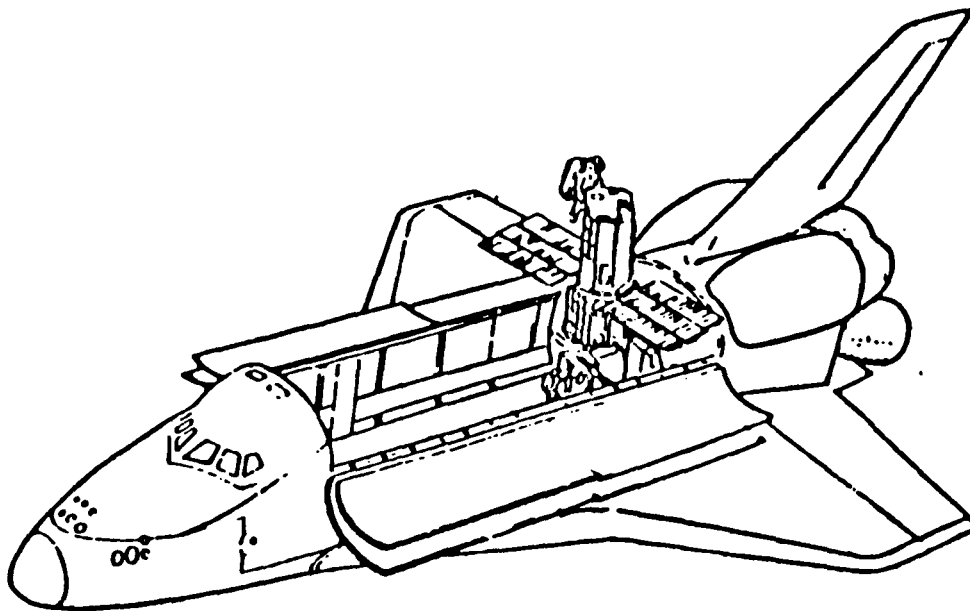

160

ORIGINAL PAGE IS
OF POOR QUALITY

Solar Maximum Repair Mission

Module Replacement
Using Manipulator
Foot Restraint

NASA

161

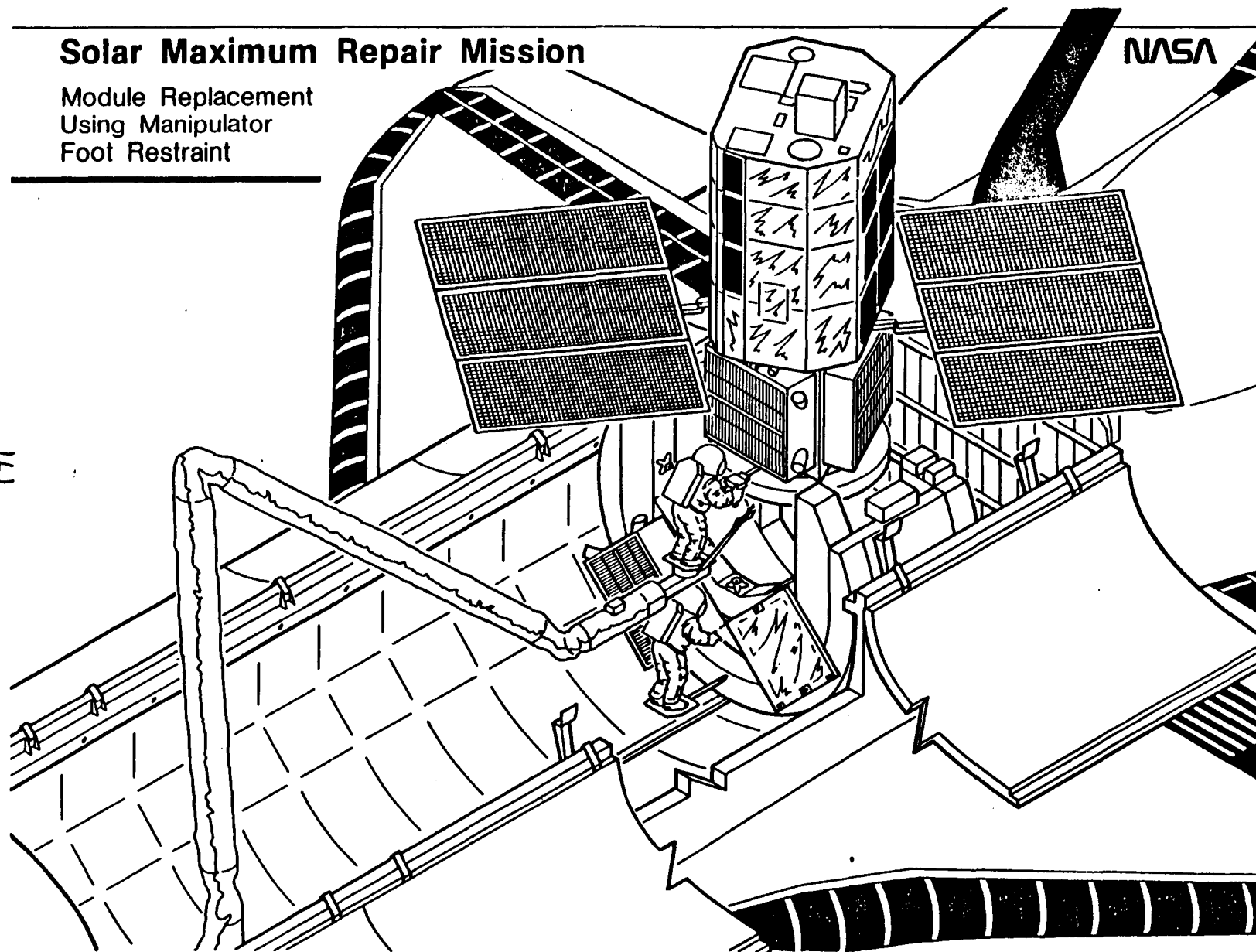

ORIGINAL PAGE IS
OF POOR QUALITY

Solar Maximum Repair Mission

Module Replacement
Using Portable
Foot Restraints

NASA
S-82-00988

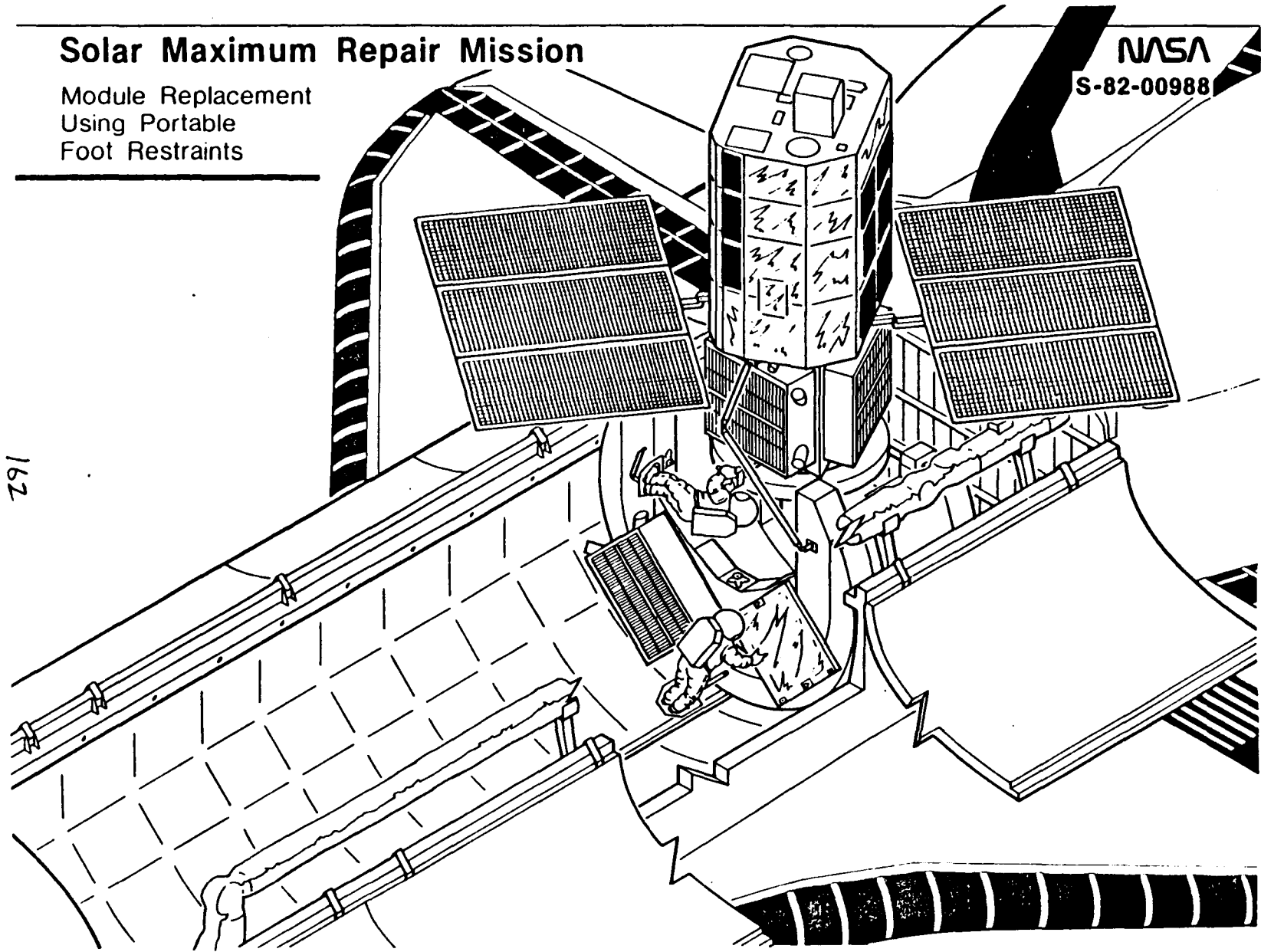

162

ORIGINAL PAGE IS
OF POOR QUALITY

SOLAR MAXIMUM REPAIR MISSION

BENEFITS TO THE STS

- VALIDATES THE OPERATION OF:
 - ON-BOARD RENDEZVOUS RADAR; FLIGHT AND GROUND BASED RENDEZVOUS SOFTWARE.
 - SHUTTLE-SPACECRAFT PROXIMITY OPERATIONS.
 - GRAPPLE AND BERTHING OF PARTIALLY DISABLED SPACECRAFT WITH THE RMS.
 - ASTRONAUT RESTRAINT SYSTEMS AS WORK STATIONS DURING EVA.

- ESTABLISHES FOR FUTURE USE:
 - MANNED MANEUVERING UNIT (MMU) FOR ASTRONAUT MOBILITY.
 - MMU AS A SURROGATE STABILIZATION CONTROL SYSTEM FOR GYRATING SPACECRAFT.
 - "DIRECT INSERTION" SHUTTLE LAUNCH TECHNIQUES FOR HIGH ALTITUDE MISSIONS.
 - FLIGHT QUALIFIED FLIGHT SUPPORT SYSTEM (FSS) TO SUPPORT SUBSEQUENT MISSIONS.

- PROVIDES OPPORTUNITIES FOR:
 - OBSERVING EXTERNAL TANK ENTRY, BREAKUP AND IMPACT DYNAMICS (HAWAII TRACKING).
 - ASSESSING THE EFFECTS OF PROLONGED SPACE EXPOSURE ON SPACECRAFT MATERIALS.
 - EVALUATING TECHNIQUES TO BE USED ON SPACE TELESCOPE AND OTHER OBSERVATORY-CLASS PAYLOADS.
 - EXPANDING THE SCOPE OF ACTIVITIES DURING EVA OPERATIONS APPLICABLE TO FUTURE MISSIONS.

163

ORIGINAL PAGE IS
OF POOR QUALITY

REPAIR MISSION COST

vs.

INITIAL INVESTMENT

EXPRESSED IN CURRENT YEAR DOLLARS, THE SOLAR MAXIMUM MISSION SPACECRAFT & INSTRUMENTS COST APPROXIMATELY \$ 200 MILLION TO DESIGN AND DEVELOP

THE ESTIMATE FOR THE REPAIR MISSION IS \$ 45-55 MILLION FOR MISSION DIRECT COSTS, MISSION OPERATIONS CAPABILITY COSTS, AND RELATED COSTS. ON THE MANIFESTED MISSION WITH THE LDEF, LAUNCH COSTS ASSIGNABLE TO THE PROVISIONS FOR THE REPAIR MISSION ARE ESTIMATED AT APPROXIMATELY \$ 10 MILLION.

THE ADDITIONAL INVESTMENT YIELDS ANOTHER TWO-TO-THREE YEARS OF SOLAR OBSERVATIONS AT A COST WHICH IS ABOUT A FOURTH OF THE CURRENT VALUE OF THE INITIAL INVESTMENT.

164

ORIGINAL PAGE IS
OF POOR QUALITY

SOLAR MAXIMUM MISSION

SUMMARY

A REPAIRED SMM CAN BE USED TO CARRY OUT A RENEWED SCIENTIFIC PROGRAM OF IMPORTANT SOLAR STUDIES FOR TWO-THREE ADDITIONAL YEARS.

ORIGINAL PAGE IS
OF POOR QUALITY

166

CO-ORBITING MECHANICS

L. E. LIVINGSTON
JOHNSON SPACE CENTER
JUNE 22, 1982

183 11183

MOTION OF CO-ORBITING SATELLITES

L. E. LIVINGSTON

6/22-23/82

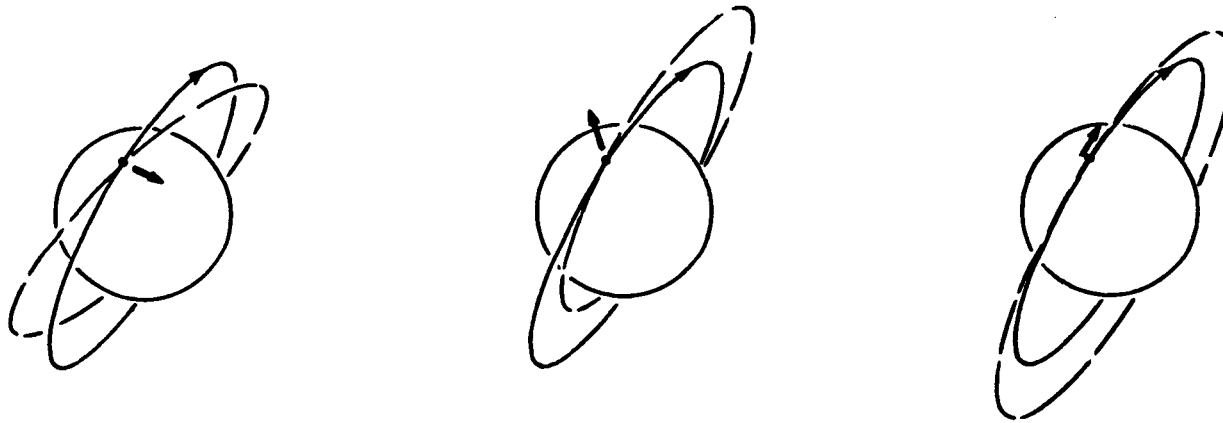

RELATIVE TO EARTH

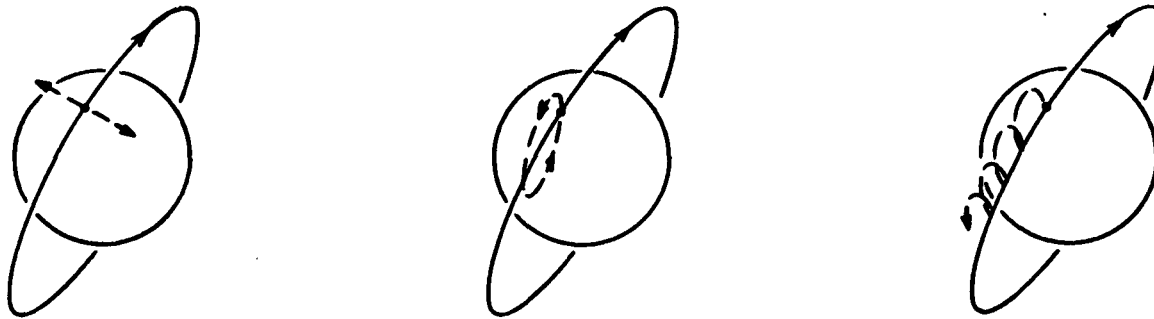

RELATIVE TO SERVICING BASE

167

ORIGINAL PAGE IS
OF POOR QUALITY

DIFFERENTIAL ORBIT DECAY

L. E. LIVINGSTON

6/22-23/82

- SOME FREE-FLYING SATELLITES (E.G., MATERIALS PROCESSING OR LARGE TELESCOPES) REQUIRE:
 - EXTENDED PERIODS WITHOUT PROPULSIVE MANEUVERS OR OTHER DISTURBANCES.
 - PERIODIC SERVICING.
- ORBITING IN THE VICINITY OF A PERMANENT BASE FACILITY COULD PERMIT SERVICING AS REQUIRED WITHOUT DEDICATED SHUTTLE FLIGHTS.
- EVEN MODERATE ORBIT DECAY REDUCES PERIOD OF FREE-FLYER ENOUGH TO CAUSE RAPID SEPARATION FROM BASE.
- IF BASE ORBIT IS NOT MAINTAINED, IT WILL GENERALLY DECAY AT DIFFERENT RATE, REDUCING BUT NOT ELIMINATING THE DIFFERENTIAL.

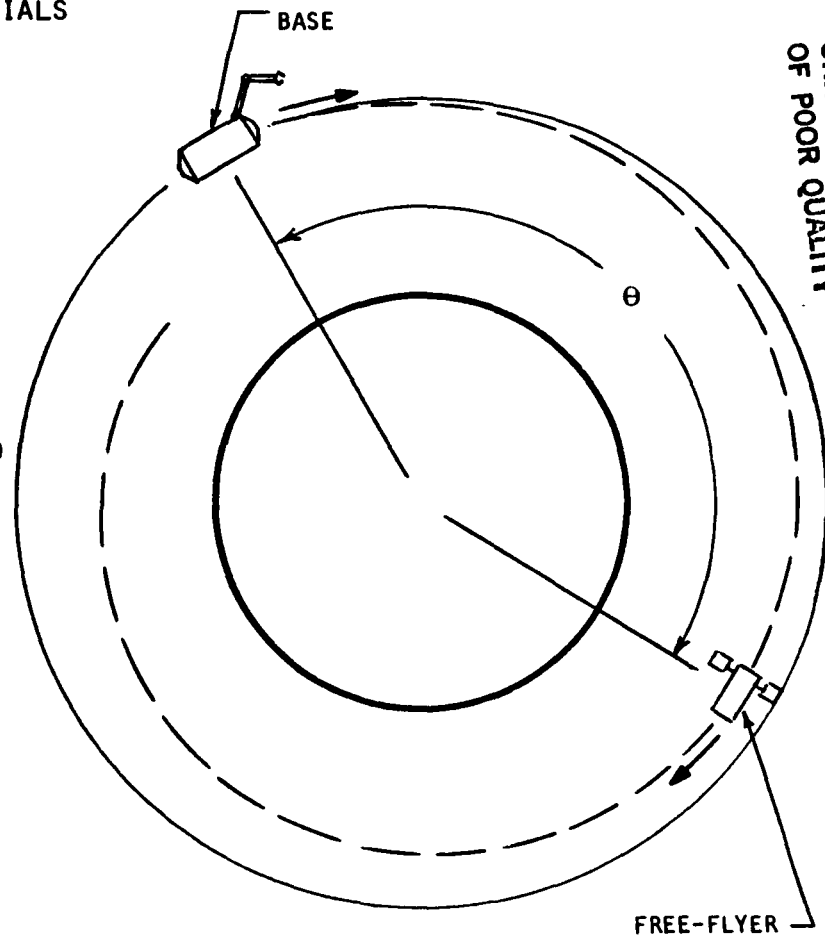

ORIGINAL PAGE IS
OF POOR QUALITY

168

ATMOSPHERIC MODELS

L. E. LIVINGSTON

6/22-23/82

169

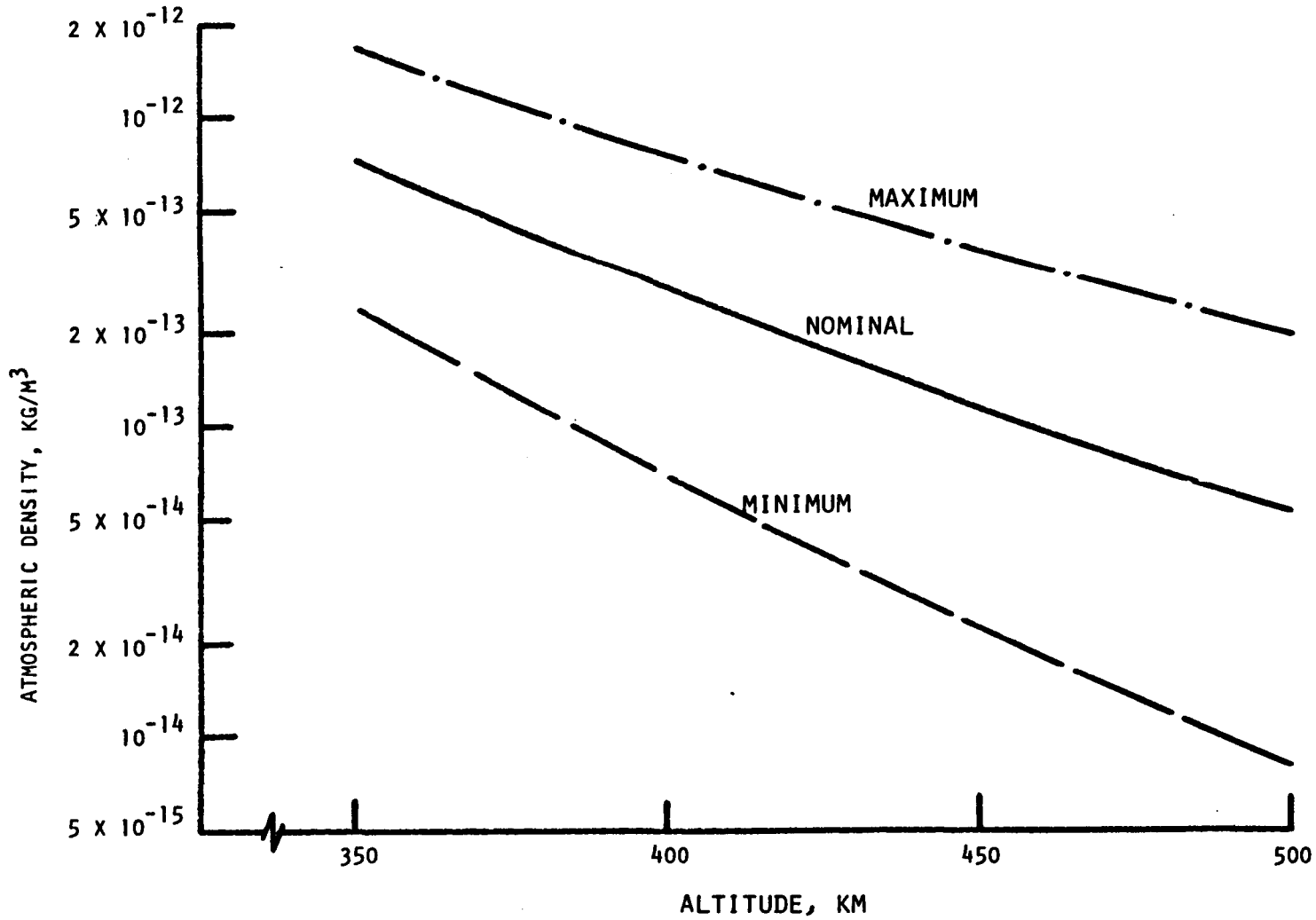

ORIGINAL PAGE IS
OF POOR QUALITY

FREE-FLYER DISTANCE FROM BASE

L. E. LIVINGSTON

6/22-23/82

170

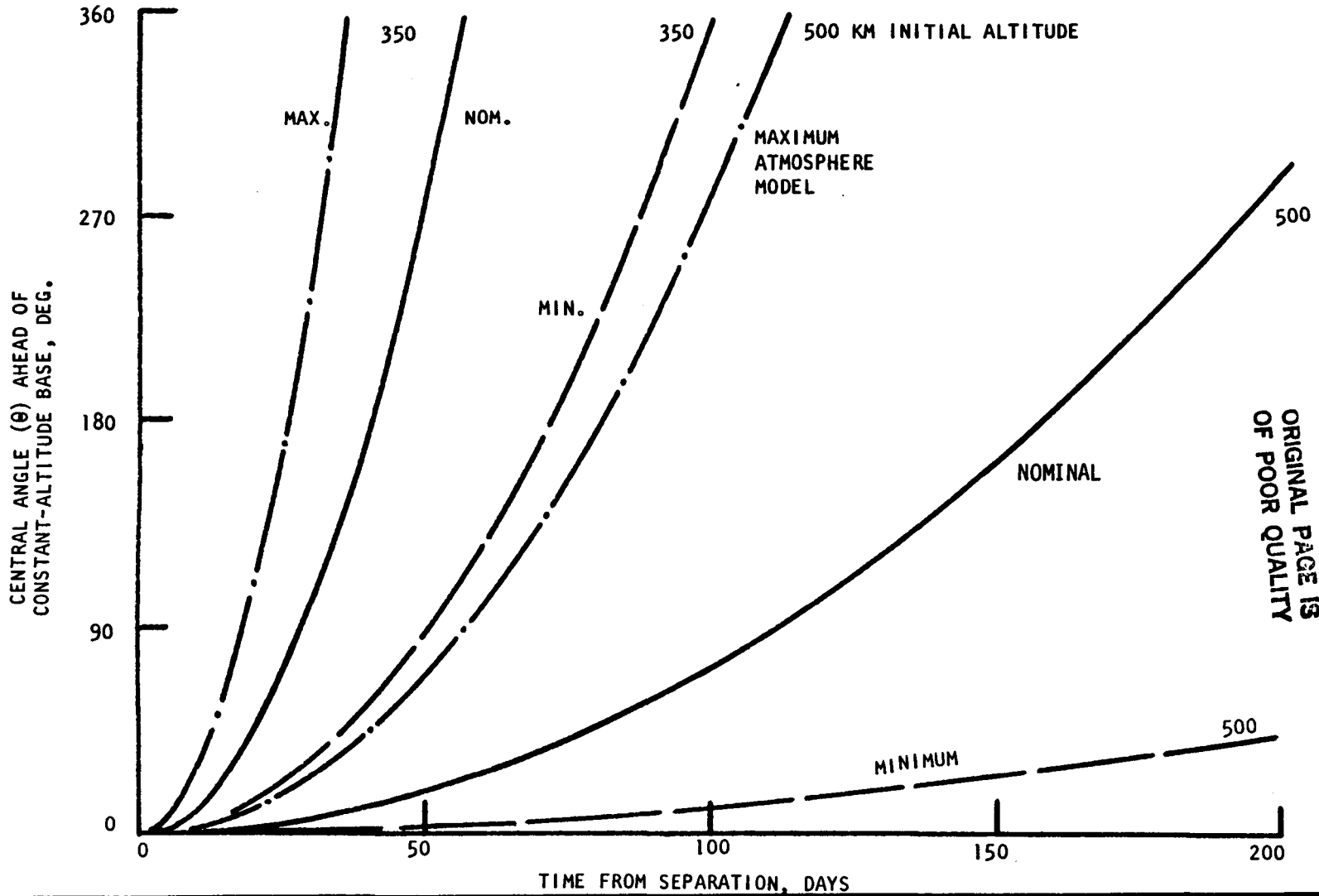

TIME FOR ONE REVOLUTION RELATIVE TO BASE

L. E. LIVINGSTON

6/22-23/82

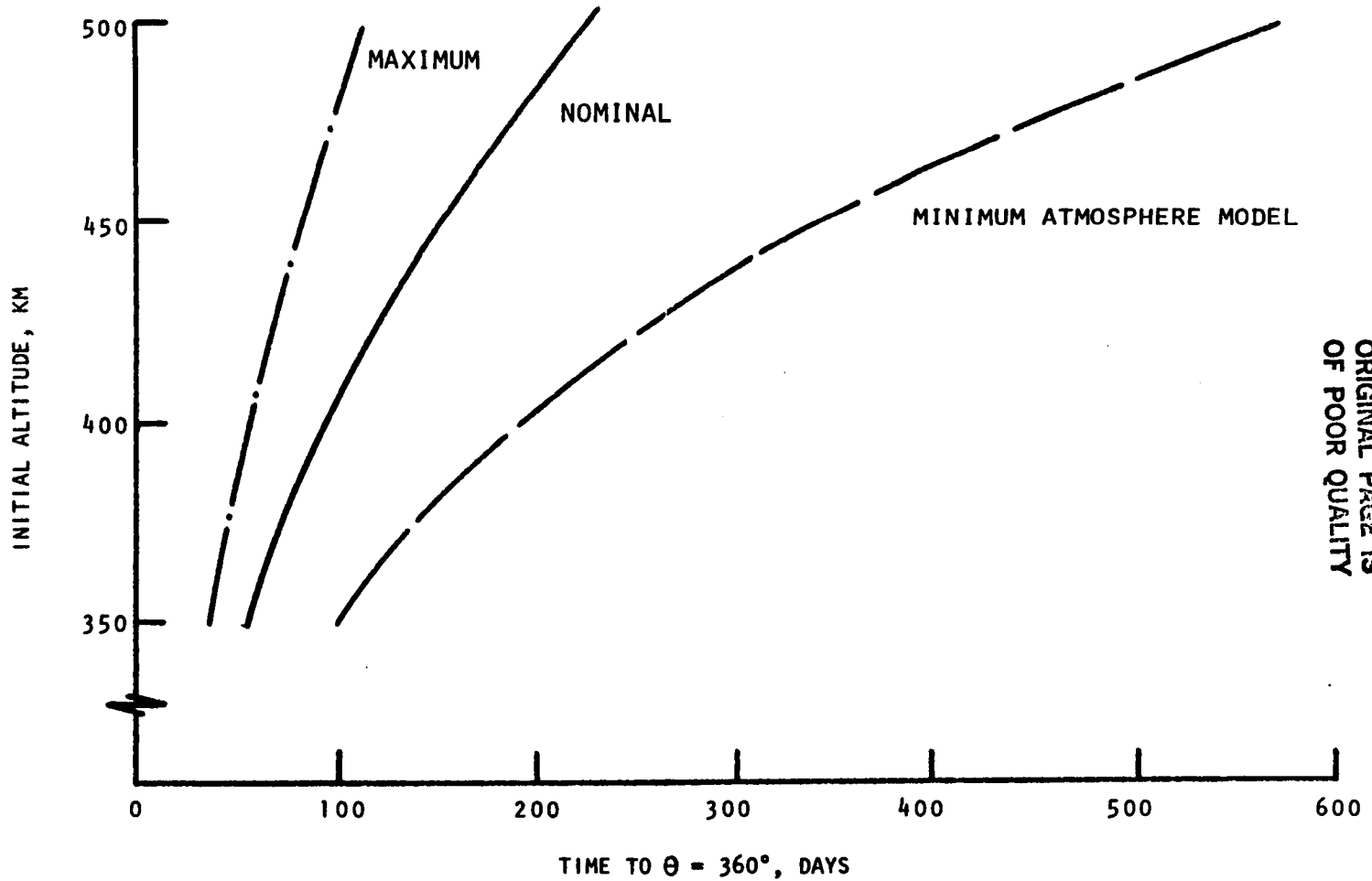

171

ORIGINAL PAGE IS
OF POOR QUALITY

ALTITUDE DIFFERENTIAL

L. E. LIVINGSTON

6/22-23/82

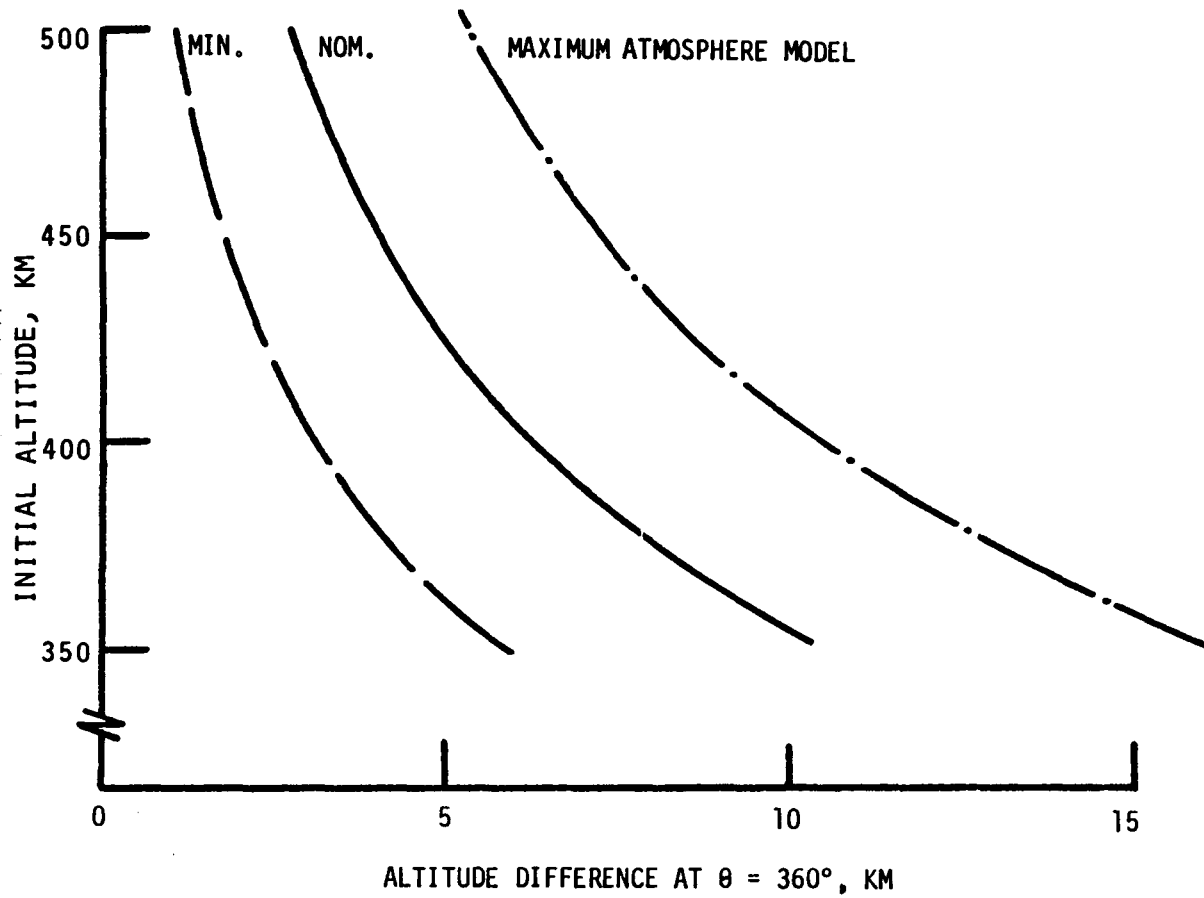

172

ORIGINAL PAGE IS
OF POOR QUALITY

RETURN AT ARBITRARY TIME

L. E. LIVINGSTON

6/22-23/82

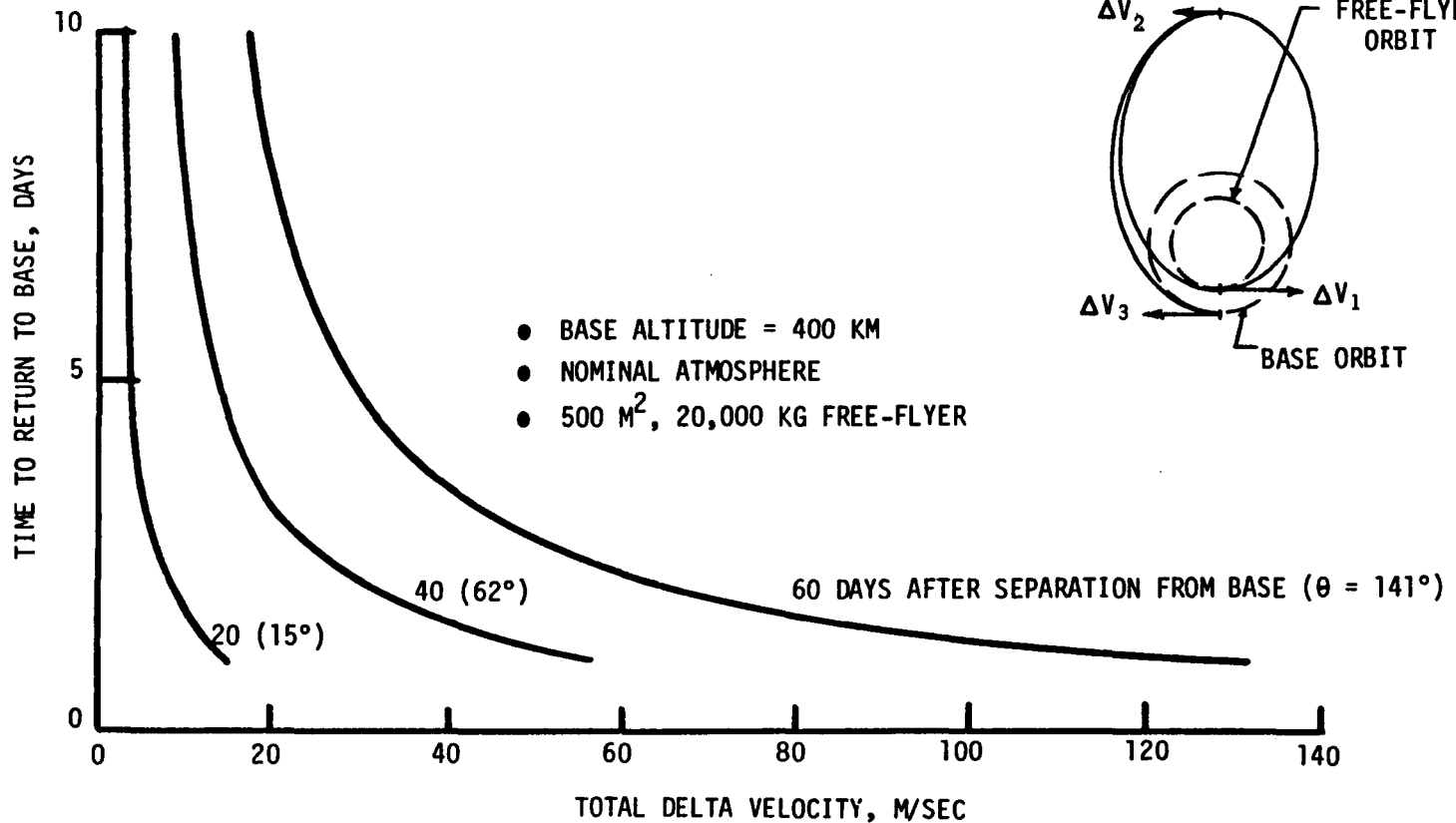

173

ORIGINAL PAGE IS
 OF POOR QUALITY

DIFFERENTIAL NODAL REGRESSION

L. E. LIVINGSTON

6/22-23/82

- EARTH'S OBLATENESS CAUSE NODE TO MOVE ALONG EQUATOR.
- RATE DEPENDS ON ALTITUDE AND INCLINATION.
- FREE-FLYER REGRESSES AT DIFFERENT RATE FROM BASE.
- PLANE CHANGE GREATLY INCREASES PROPELLANT REQUIRED FOR TRANSFER.

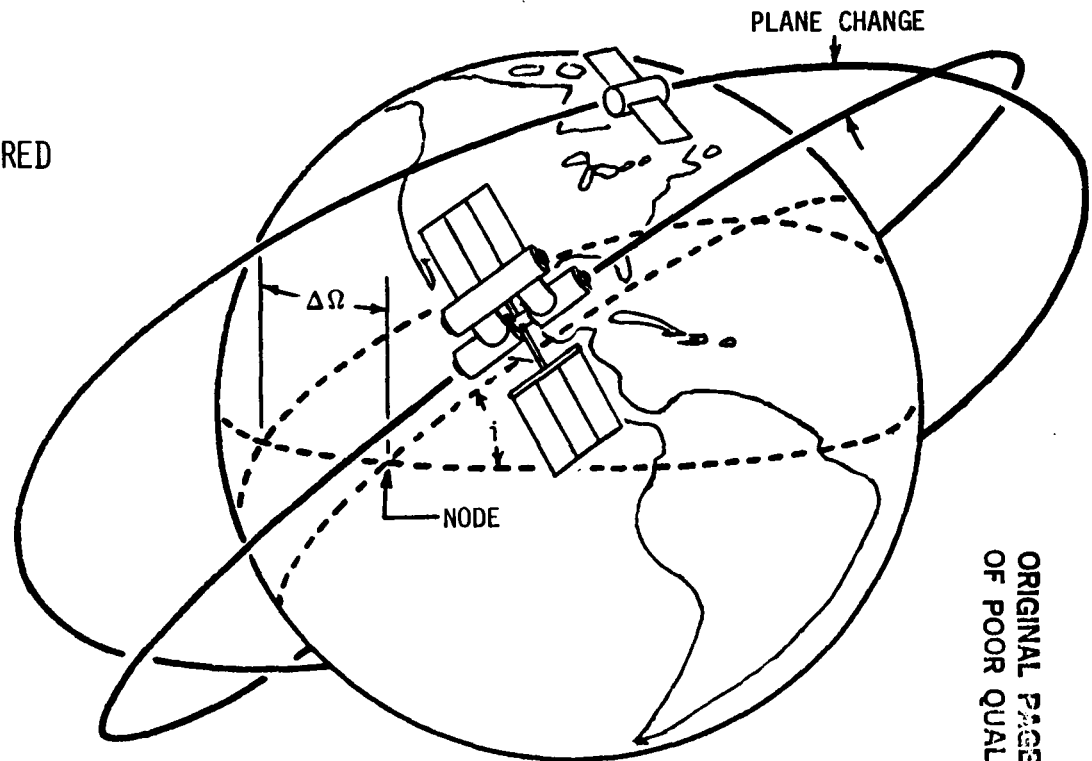

ORIGINAL PAGE IS
OF POOR QUALITY

174

ORIGINAL PAGE IS
OF POOR QUALITY

DIFFERENTIAL NODAL REGRESSION

L. E. LIVINGSTON

6/22-23/82

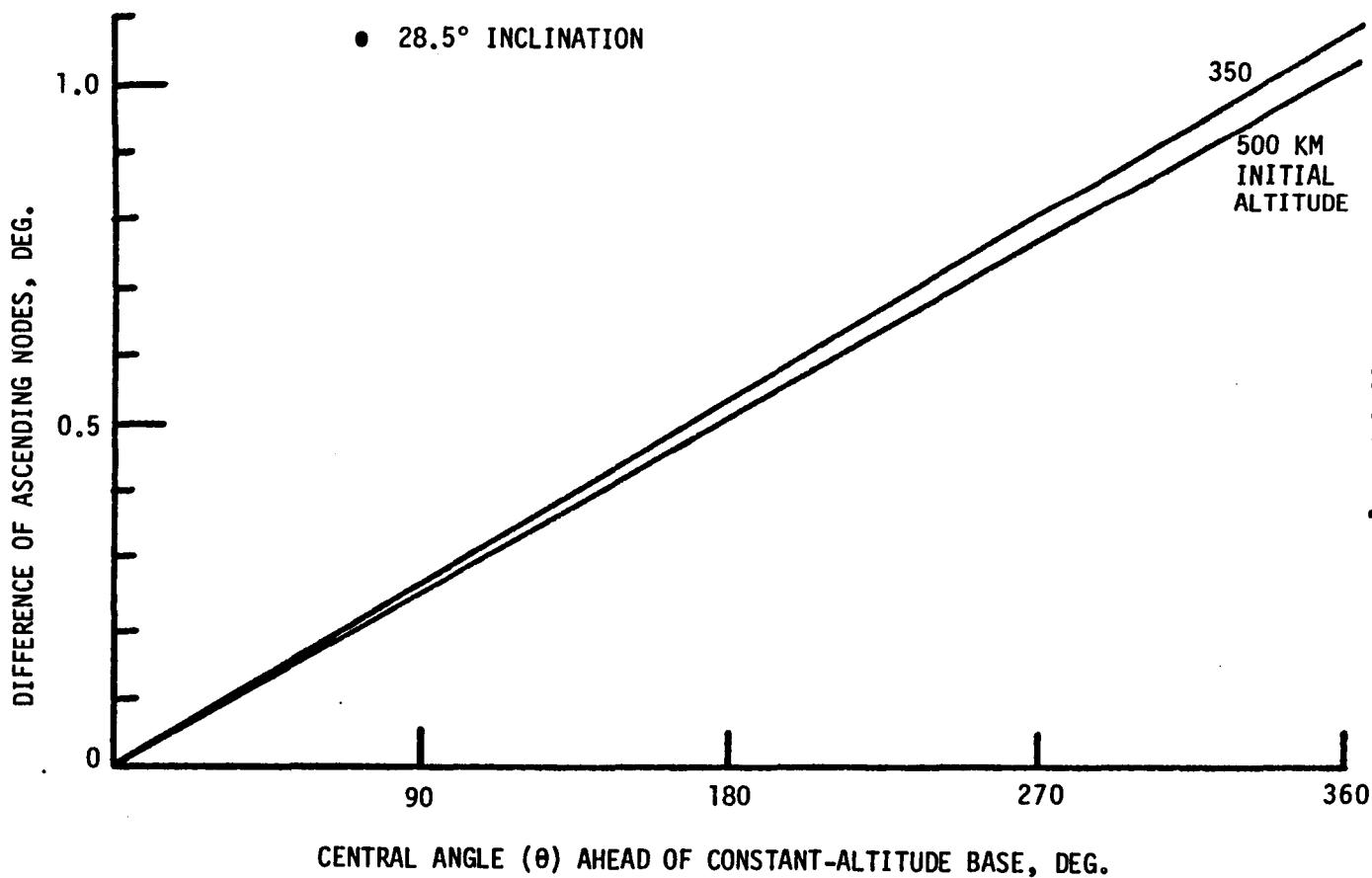

175

ORIGINAL PAGE IS
OF POOR QUALITY

DIFFERENTIAL NODAL REGRESSION

L. E. LIVINGSTON

6/22-23/82

176

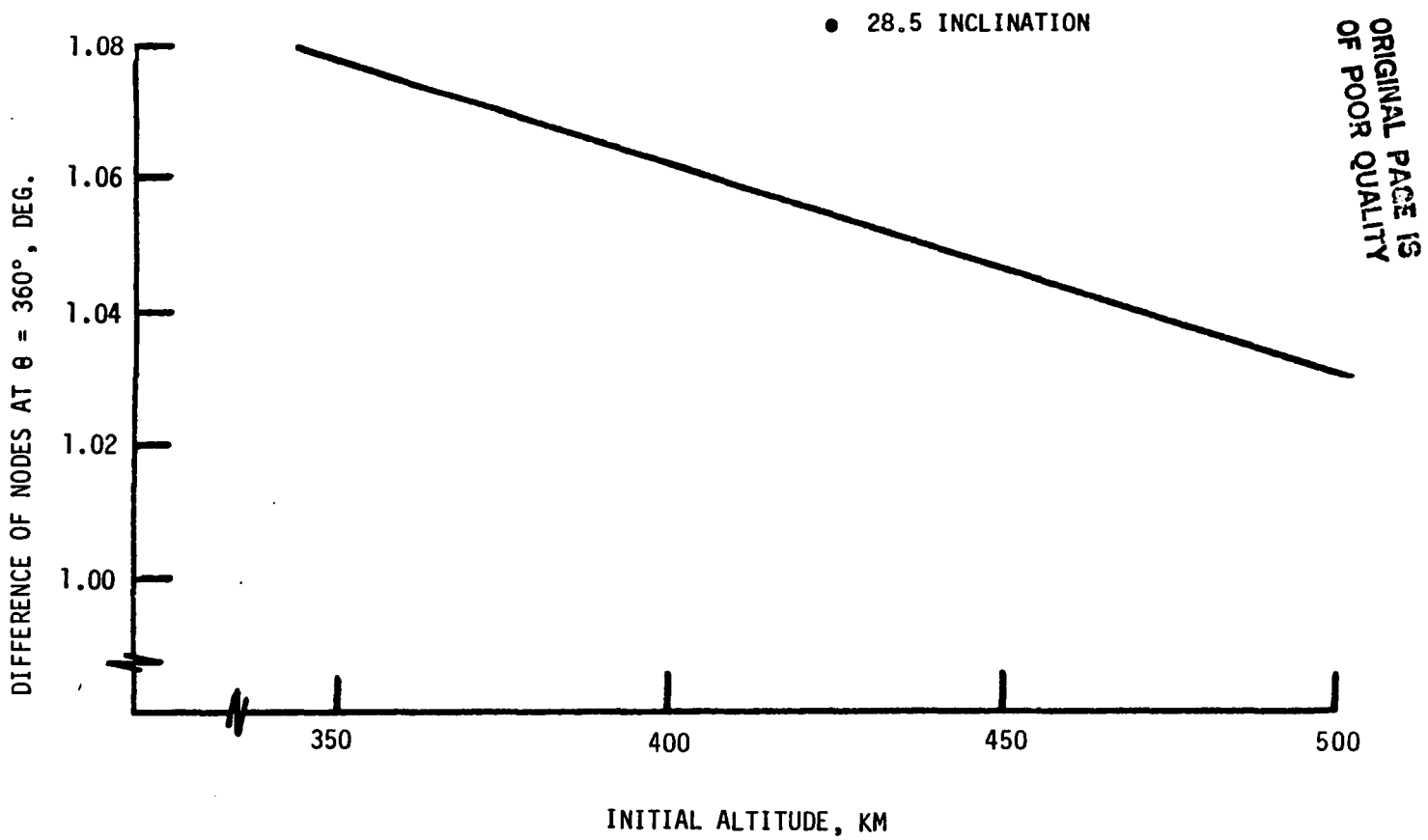

RETURN AFTER ONE REVOLUTION RELATIVE TO BASE

L. E. LIVINGSTON

6/22-23/82

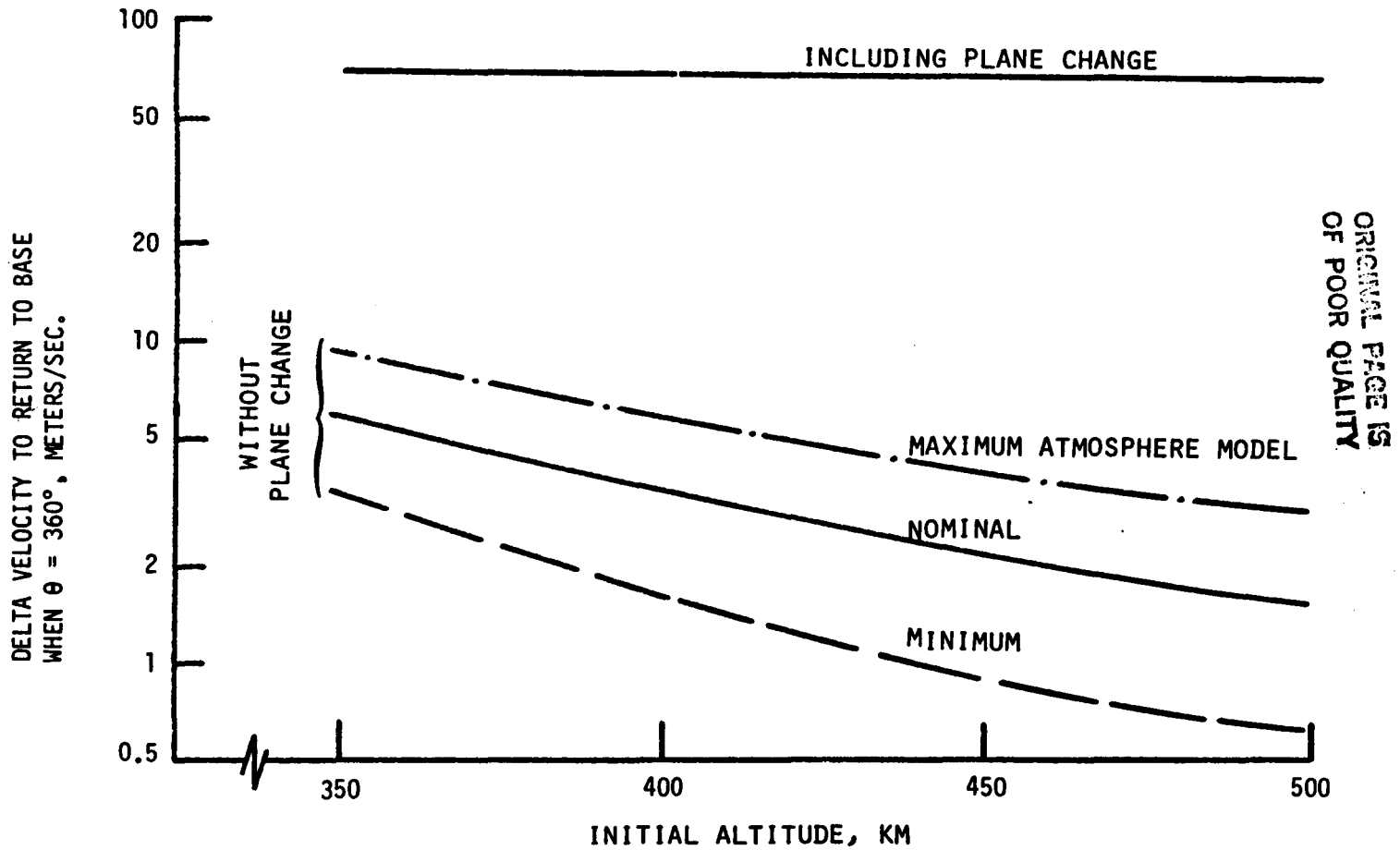

177

"BOOMERANG" CONCEPT

L. E. LIVINGSTON

6/22-23/82

- BASE MAINTAINS CONSTANT 370 KM ALTITUDE
- FREE-FLYERS PERFORM NO ORBIT MAINTENANCE
- HIGH-DRAG FREE-FLYER - 10,000 KG, 100 M² (———)
- LOW-DRAG FREE-FLYER - 25,000 KG, 35M² (---)

ORIGINAL PAGE IS OF POOR QUALITY

178

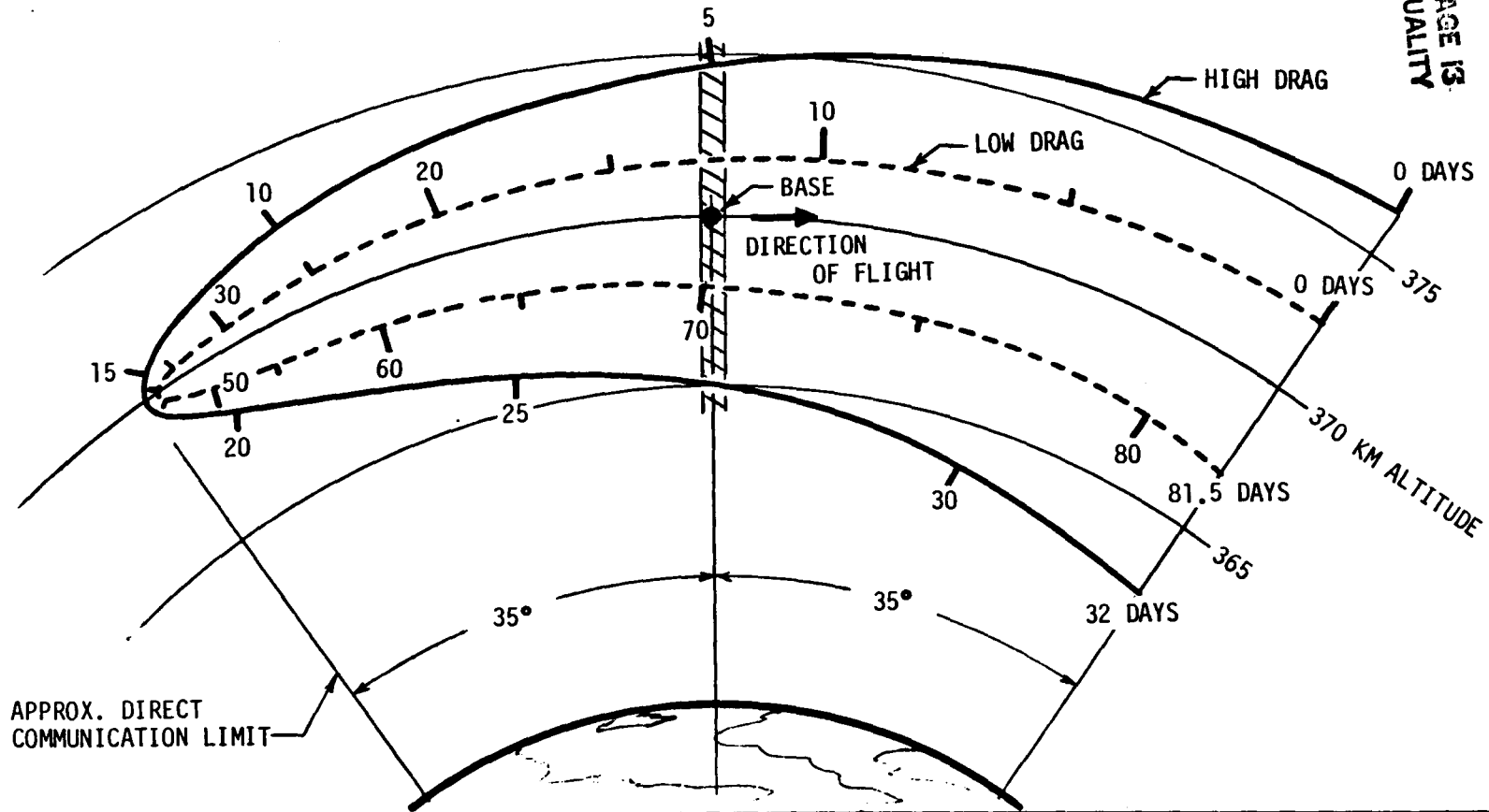

"BOOMERANG" CONCEPT

L. E. LIVINGSTON

6/22-23/82

- SEPARATION OF NODES FROM DIFFERENTIAL REGRESSION IS PROPORTIONAL TO ANGULAR SEPARATION FROM BASE, AND RETURNS TO ZERO WHEN FREE-FLYER IS BENEATH INITIAL POSITION RELATIVE TO BASE.

- LOW ΔV REQUIRED FOR REBOOST (EXAMPLES FROM PRECEDING CHART)
 - LOW DRAG: 2.2 M/SEC AT BASE
3.1 M/SEC AT COMMUNICATIONS LIMIT

 - HIGH DRAG: 5.6 M/SEC AT BASE
8.0 M/SEC AT COMMUNICATIONS LIMIT

- EASY ACCESS FROM BASE AT FREQUENT INTERVALS.

ORIGINAL PAGE IS
OF POOR QUALITY

PERIODIC CO-PLANARITY

I. E. LIVINGSTON

6/22-23/82

081

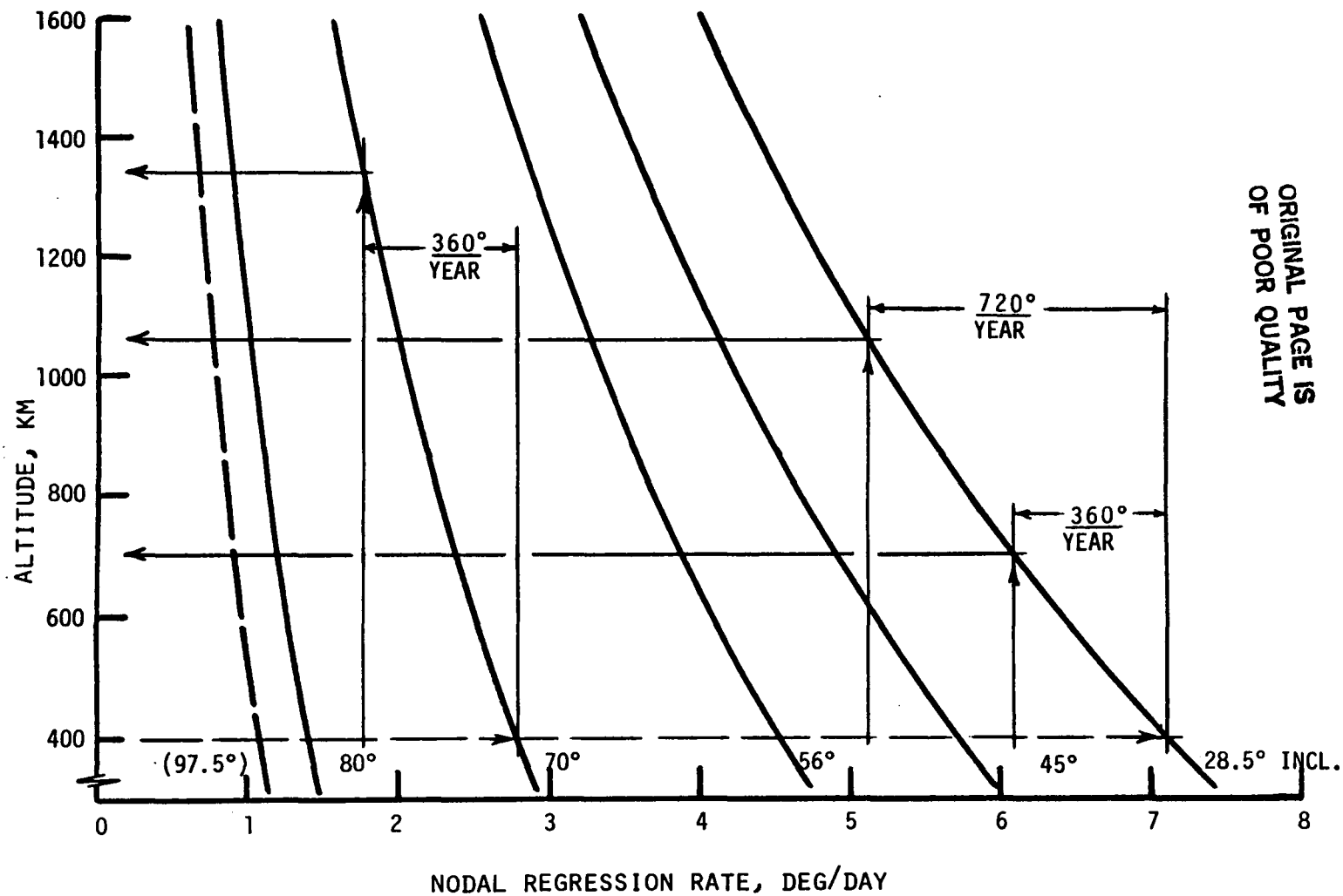

ORIGINAL PAGE IS
OF POOR QUALITY

PERIODIC CO-PLANARITY

L. E. LIVINGSTON

6/22-23/82

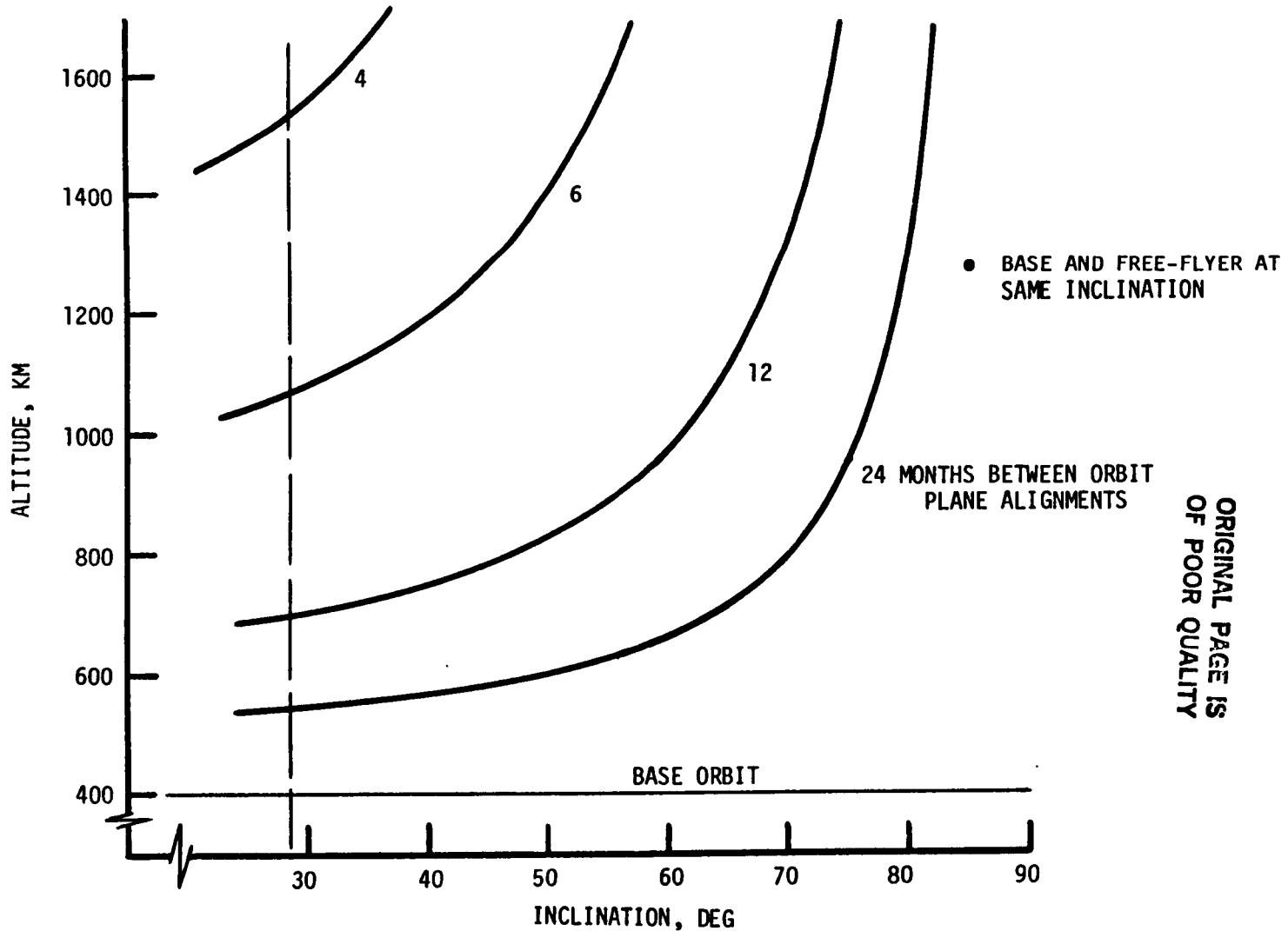

(8)

ORIGINAL PAGE IS
OF POOR QUALITY

DA 183 II 1

PAYLOAD PROCESSING
AND INTEGRATION AT KSC

JSC
SATELLITE SERVICES WORKSHOP
JUNE 22-24

ORIGINAL PAGE IS
OF POOR QUALITY

SHUTTLE/AUTOMATED PAYLOAD PROCESSING FACILITIES

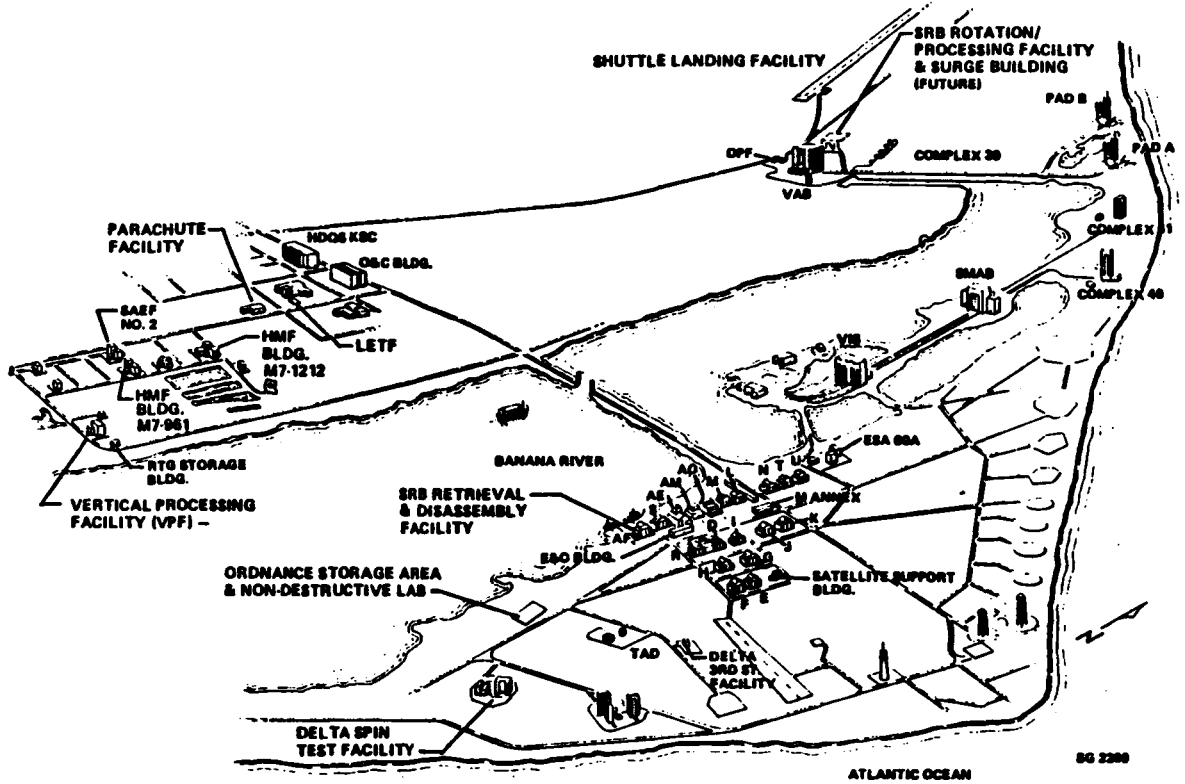

FACILITIES LAYOUT AT KSC

- 0 PAYLOAD ARRIVAL, CHECKOUT, HAZARDOUS SERVICING
- 0 MATE TO UPPER STAGE
- 0 INTEGRATE WITH OTHER PAYLOADS
- 0 INTEGRATE INTO ORBITER
- 0 INTERFACE VERIFICATION CHECKS
- 0 LAUNCH

ORIGINAL PAGE IS
OF POOR QUALITY



PAYLOAD PROCESSING FACILITIES

- 0 PAYLOADS MAY ARRIVE BY LAND, SEA, AIR
(USUALLY SPACECRAFT REQUIRING UPPER STAGES)
- 0 PAYLOAD PROCESSING FACILITY ASSIGNED FOR SPACECRAFT
OPERATIONS
 - FINAL ASSEMBLY OR BUILDUP
 - INSPECTIONS, CLEANING
 - FUNCTIONAL TESTING
- 0 "CLEAN ROOM" CONDITIONS, CRANES, SERVICES, OFFICES,
ETC. AVAILABLE

ORIGINAL PAGE IS
OF POOR QUALITY



DELTA SPIN TEST FACILITY

- 0 ESA-60 AND DELTA SPIN TEST FACILITY (DSTF) BOTH USED FOR HAZARDOUS SPACECRAFT OPERATIONS (LOADING HYDRAZINE, CRYOGENS, ORDNANCE, ETC.)
- 0 DSTF ALSO USED AS PAM-D BUILDUP AND TEST FACILITY
- 0 ALL PAM-D PAYLOADS MATED TO UPPER STAGE AT DSTF
- 0 ALL OTHER UPPER STAGES ARE MOUNTED TO SPACECRAFT IN VERTICAL PROCESSING FACILITY

ORIGINAL PAGE
BLACK AND WHITE PHOTOGRAPH



KSC INDUSTRIAL AREA

- 0 "VERTICAL" PROCESSING FACILITY
- 0 "HORIZONTAL" PROCESSING FACILITY
(O & C BUILDING)
- 0 SAEF-2

ORIGINAL PAGE
BLACK AND WHITE PHOTOGRAPH

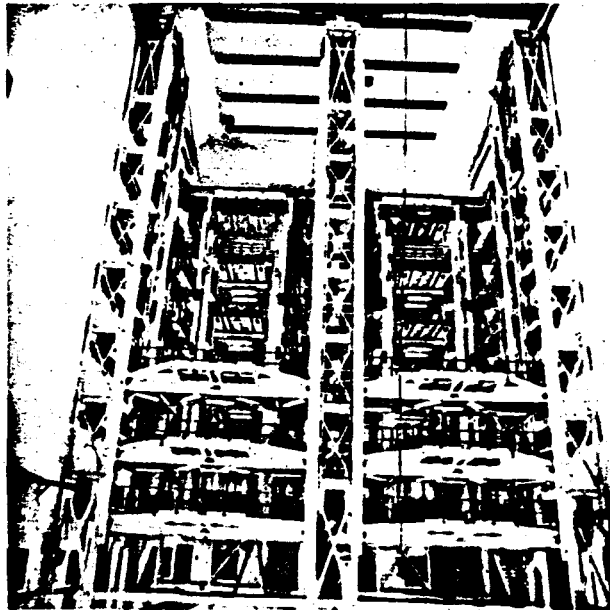

INTERIOR OF VERTICAL PROCESSING FACILITY

- 0 TWO WORKSTANDS, EACH CAPABLE OF STACKING A FULL MANIFEST
- 0 PAM-D AND SPACECRAFT PREVIOUSLY MATED
- 0 PAM-A AND IUS TRANSPORTED TO VPF, THEN SPACECRAFT MATED
- 0 ELECTRICAL, MECHANICAL, AND CITE TESTING
- 0 INSTALL FULL MANIFEST INTO CANNISTER FOR TRIP TO LAUNCH PAD

ORIGINAL PAGE
BLACK AND WHITE PHOTOGRAPH



PAYLOAD CANISTER

- 0 TRANSPORTED VERTICALLY FROM VPF
- 0 TRANSPORTED HORIZONTALLY FROM O & C
- 0 CARRIES FULL PAYLOAD MANIFEST
- 0 ENVIRONMENTALLY CONTROLLED, POWER, INSTRUMENTATION,
PURGE, ETC.
- 0 MOVED BY 48 WHEEL OMNI-DIRECTIONAL TRANSPORTER

ORIGINAL PAGE
BLACK AND WHITE PHOTOGRAPH

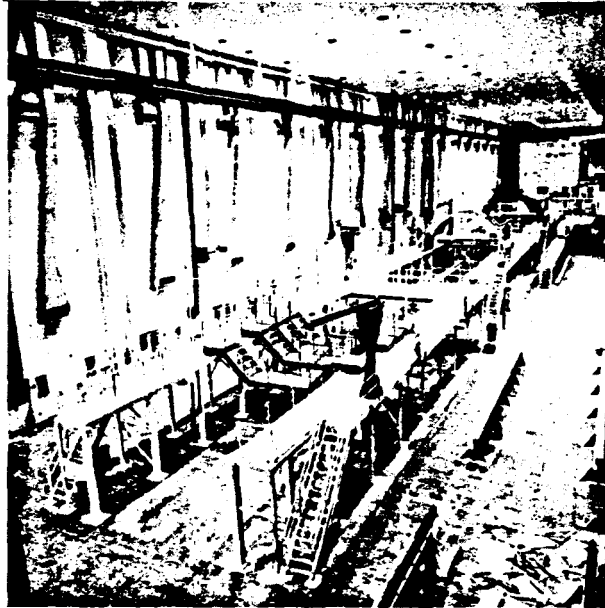

INTERIOR OF O & C BUILDING

- 0 PAYLOAD MAY ARRIVE BY LAND, SEA, OR AIR AND IS TRANSPORTED TO O & C BUILDING
- 0 CONDUCT FINAL BUILDUP, TEST SYSTEMS, VERIFY INTERFACES, CITE TESTING
- 0 NO ORDNANCE OR PROPULSIVE STAGES
- 0 LOAD INTO CANISTER HORIZONTALLY

ORIGINAL PAGE
BLACK AND WHITE PHOTOGRAPH

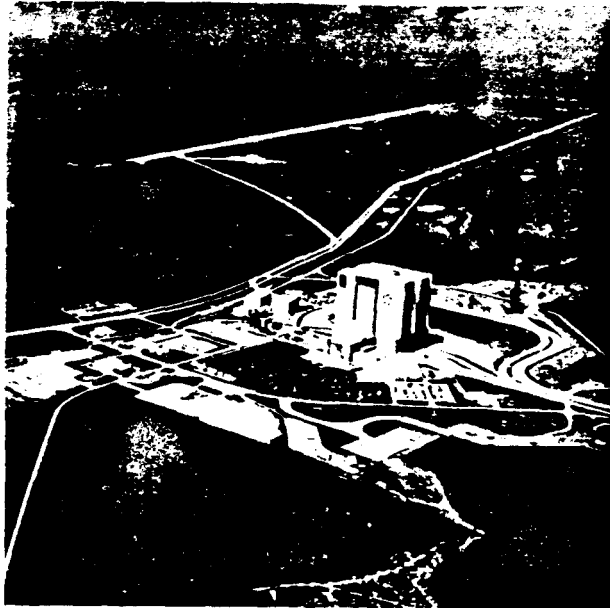

LC-39 LANDING, PROCESSING & STACKING AREA

- 0 ORBITER LANDS ON RUNWAY, TOWED TO OPF
- 0 ORBITER PROCESSED IN OPF, SRB'S AND ET STACKED SIMULTANEOUSLY IN VAB
- 0 ORBITER TOWED TO VAB AND STACKED WITH SRB'S/ET
- 0 SHUTTLE INTERFACE TEST TO VERIFY ALL CONNECTIONS/ SYSTEMS
- 0 STACKED STS VEHICLE MOVED TO PAD ON MOBILE LAUNCHER

ORIGINAL PAGE
BLACK AND WHITE PHOTOGRAPH

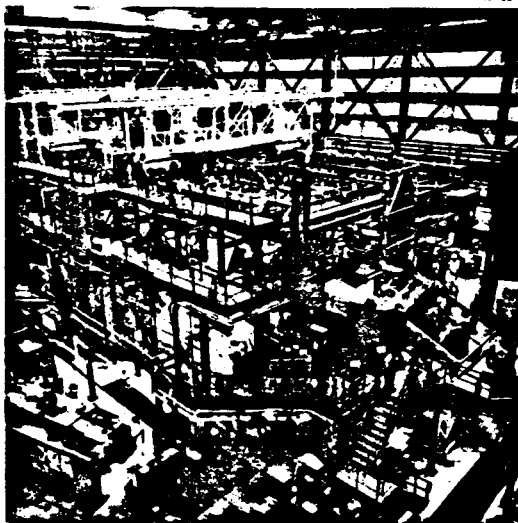

"HORIZONTAL" PAYLOAD INTEGRATION TO ORBITER

- 0 TRANSPORTED FROM O & C TO OPF VIA CANISTER/TRANSPORTER
- 0 REMOVAL/INSTALLATION OF FLIGHT KITS AND/OR SATELLITE SERVICING EQUIPMENT
- 0 PAYLOAD HOISTED FROM CANISTER, LOWERED INTO ORBITER BAY AND SECURED
- 0 SHUTTLE/PAYLOAD INTERFACES CONNECTED
- 0 ORBITER INTEGRATED TEST CONDUCTED TO VERIFY INTERFACES
- 0 PAYLOAD BAY CLOSED OUT AND DOORS CLOSED

ORIGINAL PAGE
BLACK AND WHITE PHOTOGRAPH

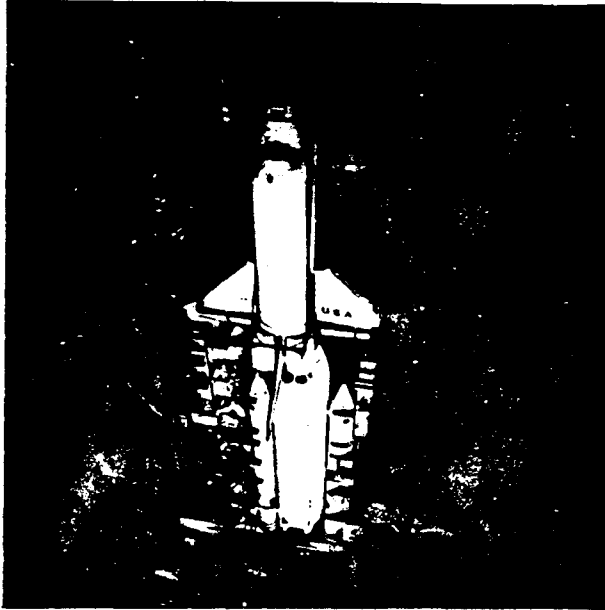

VEHICLE ASSEMBLY BUILDING OPERATIONS

0 "HORIZONTAL" PAYLOADS:

- ORBITER MATED TO ET/SRB'S
- DOORS REMAIN CLOSED
- NO PAYLOAD ENVIRONMENTAL CONTROL UNTIL MATED WITH ET
- ENVIRONMENTAL CONTROL ON WAY TO LAUNCH PAD

0 "VERTICAL" PAYLOADS:

- ORBITER MATED TO ET/SRB'S
- DOORS REMAIN CLOSED
- PAYLOAD BAY EMPTY, PAYLOADS AND CRADLES TO BE LOADED AT PAD

ORIGINAL PAGE
BLACK AND WHITE PHOTOGRAPH

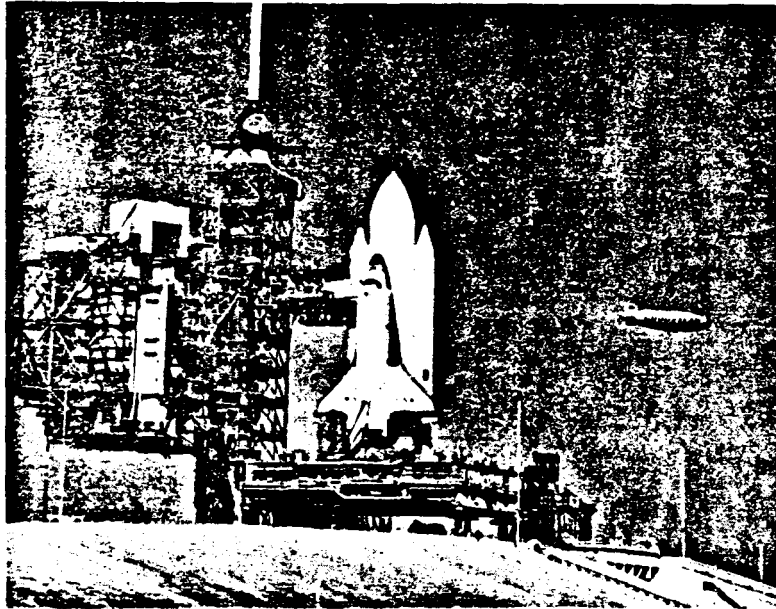

PAD OPERATIONS
(RSS ROLLED BACK)

- 0 MLP HARD DOWN, CONNECT SERVICES
- 0 "HORIZONTAL" PAYLOADS ARE IN THE ORBITER BAY.
NORMALLY NO ACCESS, BUT DOORS CAN BE OPENED IF
NECESSARY
- 0 "VERTICAL" PAYLOADS ARE TRANSPORTED TO PAD IN
CANISTER AND OFFLOADED INTO ROTATING SERVICE
STRUCTURE (RSS). SOME PAYLOAD TASKS/TESTS
PERFORMED

ORIGINAL PAGE
BLACK AND WHITE PHOTOGRAPH



PAD OPERATIONS
(RSS IN POSITION)

- 0 RSS PROVIDES ACCESS, PROTECTION
- 0 "VERTICAL" PAYLOADS INSERTED INTO ORBITER, INTERFACES
CONNECTED AND TESTED
- 0 SERVICING OPERATIONS (FUEL CELLS, RCS, OMS, ETC.)
- 0 FINAL COUNTDOWN

ORIGINAL PAGE
BLACK AND WHITE PHOTOGRAPH

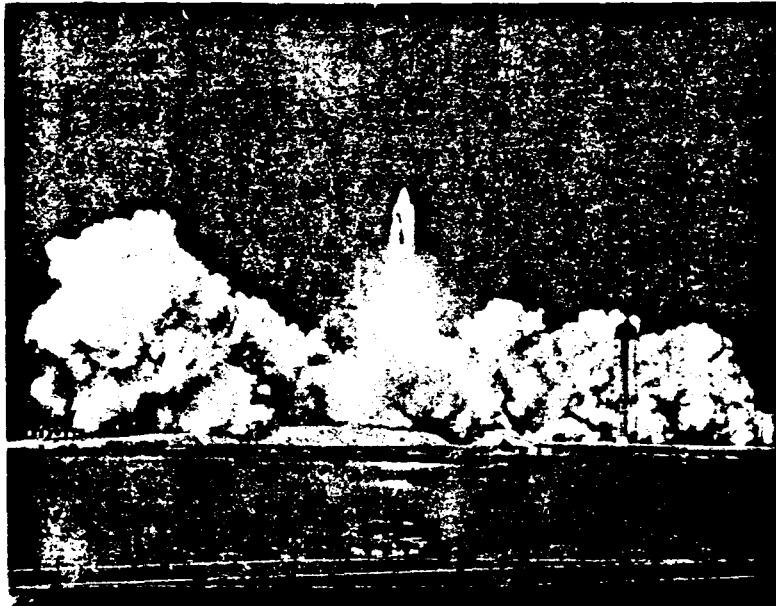

LAUNCH

0 NO PAYLOAD ACCESS DURING FINAL 20 HOURS

ORIGINAL PAGE
BLACK AND WHITE PHOTOGRAPH

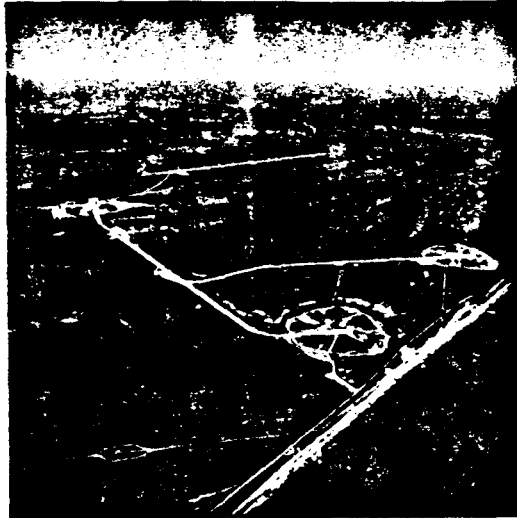

SHUTTLE LANDING FACILITY

- 0 RUNWAY 15000 FT X 300 FT
- 0 AFTER LANDING, TOW ORBITER TO OPF FOR PAYLOAD
(OR CRADLE) REMOVAL, ORBITER SERVICING
- 0 CRADLES RETURNED TO OWNERS AT OPF. SPACELAB
TAKEN TO O & C. ABORTED PROPULSIVE STAGES
RETURNED TO VPF

ORIGINAL PAGE IS
OF POOR QUALITY

2789 11185

ADVANCED EXTRAVEHICULAR MOBILITY UNIT STUDY

- REQUIREMENTS

- DESIGN CONSIDERATIONS
 - RADIATION PROTECTION
 - EVA OPERATIONAL PRESSURE
 - MOBILITY EFFECTS
 - TOOL/GLOVE/EFFECTOR
 - ANTHROPOMETRIC DEFINITION
 - EVA LIGHTING
 - EQUIPMENT TURNAROUND



197

The features of the advanced EMU which make it an effective EVA system are:

1. Quick reaction--no pre-breathing is required to transfer from sea level habitat pressures to EVA operations. This requires an EMU operational pressure of approximately 8 psi.
2. Full mobility--the advanced EMU implements a complete mobility system which closely simulates the full nude mobility range of its user. The mobility techniques are passively stable and exhibit extremely low torques to minimize the energy expenditures and assure productive and extended EVA work cycles.
3. Long life components--the construction of large space stations will require extensive numbers of EVA workers who will be on the work site for months at a time. This will require highly reliable and long life components (greater than one million cycles).
4. Extended modularity sizing and maintenance systems--by designing the improved EMU as a series of standard components which are "length" sized to fit individual workers by quick connect components, "shift" assembly of EMU components to fit workers on alternate 8-hour shifts will significantly reduce the in-orbit inventory of suit components and the attendant volume required for storage. The improved EMU will make EVA so efficient that the most effective way to handle many in-orbit satellite launches and recoveries will be through the use of EVA rather than fully automated systems.

196

196
1111
184



GUIDELINES

"THE OPTIMIZED EVA SYSTEM IS CONSIDERED FOR THE YEAR 2000 OPERATIONAL REQUIREMENTS."

"LOGICAL TRANSITION FROM THE CURRENT EMU TO THE OPTIMUM (CIRCA 2000) SYSTEM WILL BE DEFINED."

RESULTS

THE OPTIMUM EVA SYSTEM WILL MEET THE FOLLOWING REQUIREMENTS:

- 0 NO PRE-BREATH AND MIXED O₂/N₂ EMU ENVIRONMENT
- 0 FULL MOBILITY
- 0 IN-ORBIT MINIMUM SERVICING
- 0 EXTENDED MODULARITY TO ENHANCE SERVICING AND LOGISTICS
- 0 USEFUL IN-ORBIT LIFE PER OPERATIONAL CYCLE IS ; 1M
- 0 RADIATION PROTECTION (UP TO 300 NM @ 60° INCLINATION)

199

ORIGINAL PAGE IS
OF POOR QUALITY





ADVANCED EMU REQUIREMENTS

NASA

LOCKHEED

GENERAL

TASKS--EVA CONSTRUCTION, DEPLOYMENT, STOWAGE, OPERATION, MAINTNEANCE, AND REPAIR

PERSONNEL--EVA-TRAINED ONLY

SORTIE--WORK CYCLE 6 HOURS CONTINUOUS EVA; SINGLE OR MULTIPLE SHIFT

--NO PRE-BREATHING

RESTRAINT--FOOT AND/OR TORSO

--TETHERED EQUIPMENT

EVA TRANSLATION--HAND RAILS, HAND HOLDS, CRANE, PERSONAL PROPULSION SYSTEM, FOOT RAILS

STOWAGE--IN HABITAT

LIGHTING--AREA AND EMU INTEGRAL

ORIGINAL PAGE IS
OF POOR QUALITY



200



ADVANCED EMU RADIATION PROTECTION

NASA

LOCKHEED

o VAN ALLEN BELT RADIATION USED FOR ANALYSIS

- SOLAR FLARES AND EXOATMOSPHERIC NUCLEAR BLASTS NOT CONSIDERED
- COSMIC RAY INSIGNIFICANT

o CONCLUSION:

- NORMAL EVA SYSTEM DENSITIES SUFFICIENT FOR LEO RADIATION PROTECTION
- NOT TRUE FOR GEO

201

ORIGINAL PAGE IS
OF POOR QUALITY





ADVANCED EMU RADIATION PROTECTION (CONT'D)

NASA

LOCKHEED

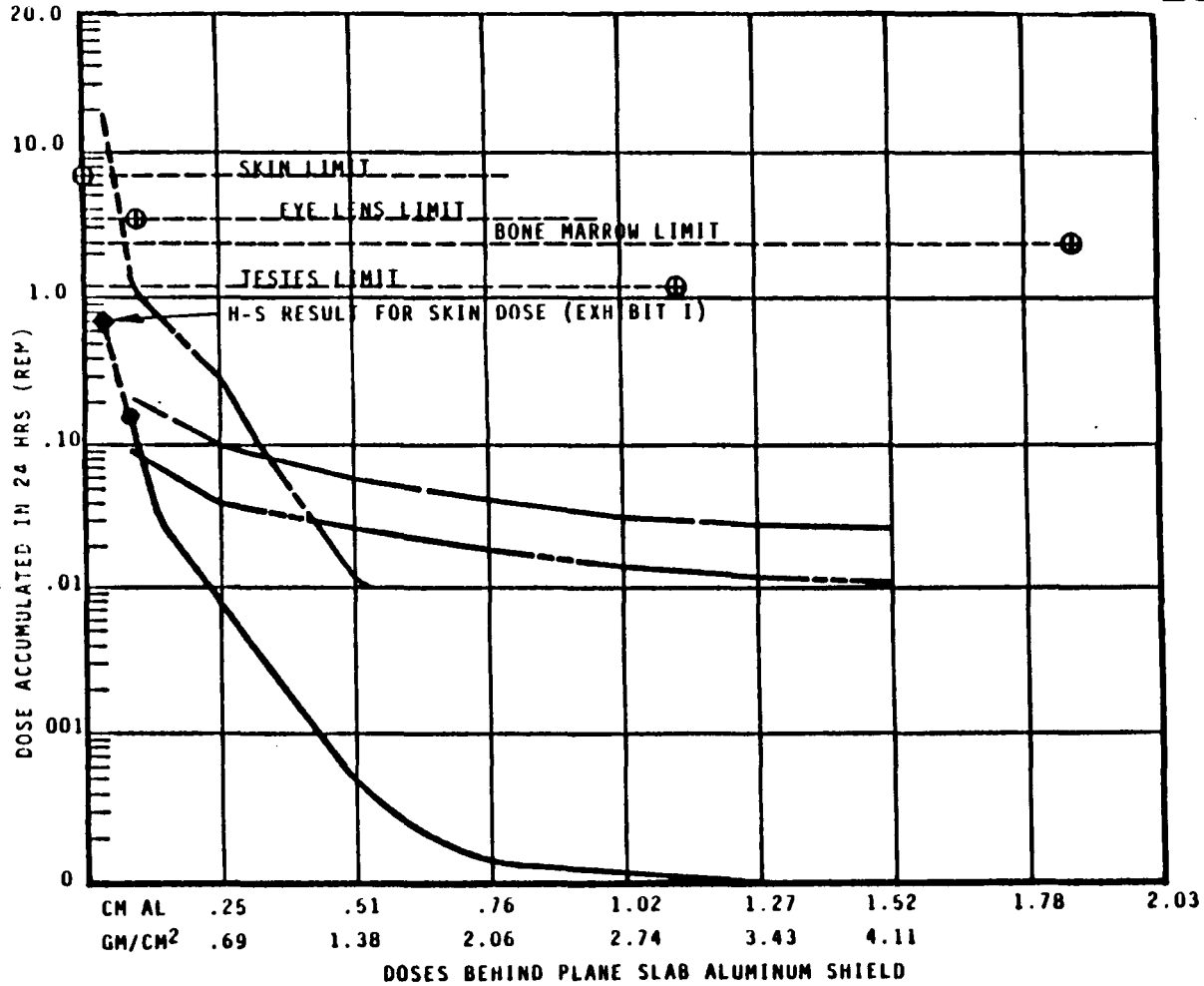

-----	PROTON	} 220 ² X NMI X 28 ⁵ °	-----	PROTON	} 300 ² X NMI X 60°
-----	ELECTRON		-----	ELECTRON	

202

ORIGINAL PAGE IS OF POOR QUALITY



ADVANCED EMU OPERATIONAL PRESSURE

NASA

LOCKHEED

- 0 RECOMMEND--SEA LEVEL PRESSURE IN HABITAT (14.7 PSIA)
 - 8 PSIA SUIT PRESSURE WITH 50% N₂ - 50% O₂ MIX
- 0 NO PRE-BREATHE OF O₂ REQUIRED
- 0 LONG-TERM EXPOSURE TO HIGH O₂ CONCENTRATIONS UNDESIRABLE
- 0 HABITAT PRESSURE AFFECTS
 - COOLING POWER REQUIREMENTS
 - AVIONICS RELIABILITY
 - FLAMMABILITY HAZARDS
 - O₂ TOXICITY
 - BIOLOGICAL/PHYSIOLOGICAL AND MATERIAL PROCESS EXPERIMENTS

203

ORIGINAL PAGE IS
OF POOR QUALITY





ADVANCED EMU OPERATIONAL PRESSURE (CONT'D)

NASA

LOCKHEED

- 0 8 PSI TECHNOLOGY IS AVAILABLE
- 0 ON-GOING PROGRAM TO DEMONSTRATE ADVANCED EMU FEASIBILITY
- 0 POTENTIAL FOR NEAR-TERM IMPLEMENTATION

204

ORIGINAL PAGE IS
OF POOR QUALITY





ADVANCED EMU MOBILITY EFFECTS

NASA

LOCKHEED

0 THE ADVANCED EMU WILL IMPLEMENT NON-PROGRAMMED FLEXIBLE JOINTS AS FOLLOWS:

- SHOULDER 3-AXIS
- ELBOW SINGLE-AXIS
- WRIST 3-AXIS
- WAIST 2-AXIS
- HIP 3-AXIS
- KNEE SINGLE-AXIS
- ANKLE 2-AXIS

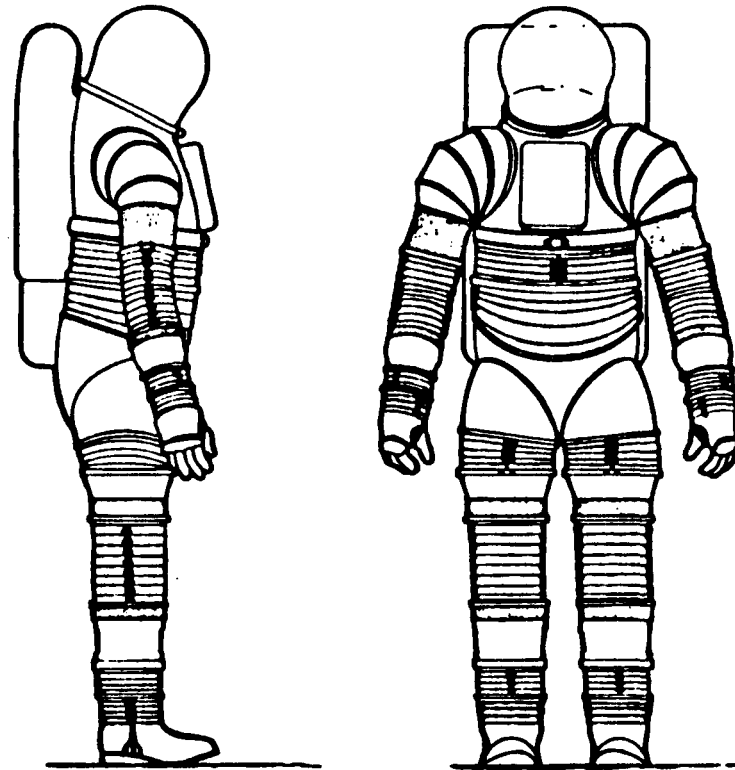

0 FULL MOBILITY FAVORABLE AFFECTS

- TRAINING TIME
- EVA AID COMPLEXITY
- TASK TIME LINES

205

ORIGINAL PAGE IS
OF POOR QUALITY





206

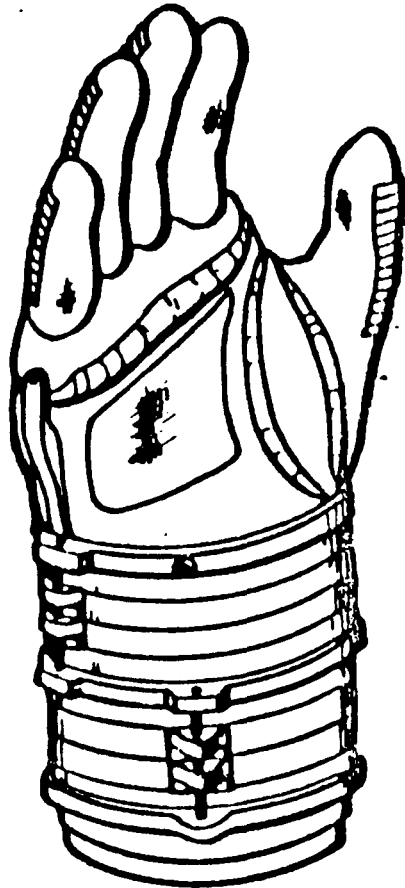

- o FOR ORBITS CONSIDERED, RADIATION IS NOT A SERIOUS PROBLEM
 - GLOVE USED FOR LEO
 - FUTURE GEO WILL REQUIRE INCREASED HAND PROTECTION/EFFECTOR SYSTEM

- o GLOVE REQUIRES
 - 1ST METACARPAL JOINT IMPLEMENTATION
 - GOOD TOOL "GRIP INTERFACE"
 - THUMB-FINGER OPPOSITION
 - IN-ORBIT REPLACEMENT OF GLOVE ELEMENT TO WRIST

ORIGINAL PAGE IS
OF POOR QUALITY





- 0 NEED FOR MULTI-PURPOSE POWER ELEMENT FOR
 - VARIABLE TORQUE MULTI-ROTATION
 - RECIPROCAL MOVEMENT
- 0 INTERFACE TO GLOVE OR TO RADIATION PROTECTIVE "CAN"

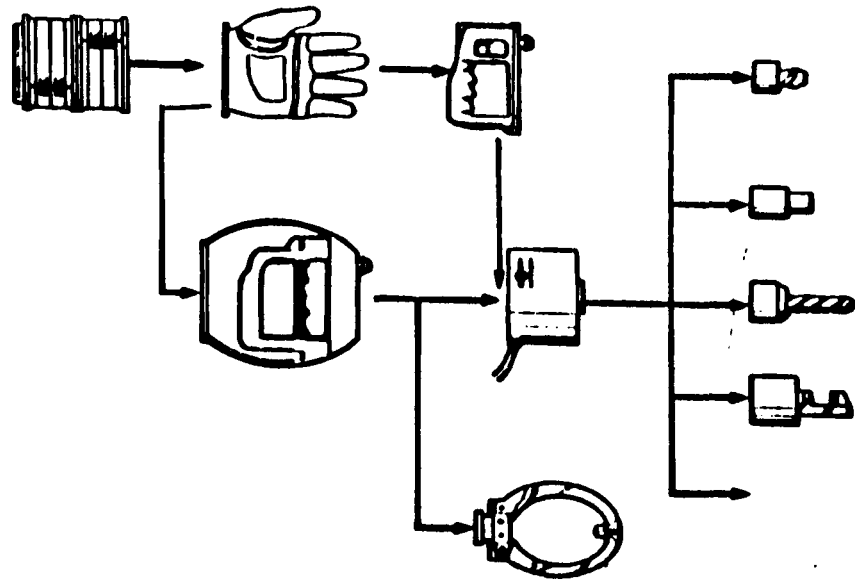

207

ORIGINAL PAGE IS OF POOR QUALITY



EVA SYSTEM ANTHROPOMETRICS

Early space suits were designed as derivations of emergency pressure flight suits. Such suits were never intended for use while pressurized except under emergency conditions for short periods of time. The demand for mobility while pressurized grew with the advent of Extravehicular Activity (EVA) and lunar exploration.

A group of developmental space suits which began with the JSC-Litton hard space suits approached the problem of pressurized mobility from a new direction. Those suits were conceived and designed as articulated anthropomorphic structures instead of as specialized articles of clothing. Such an articulated structure is constructed of an assembly of specially formed elements connected to flexible joint elements.

It was apparent that the only way such an assembly could be sized to a range of subject sizes was to provide different sized elements that could be assembled in combination to fit an individual.

This sizing approach was explored in the JSC-Litton RX-3 program and in the JSC-AiResearch AES program. In both cases, the concept was to provide suit element cross sections that would accommodate the largest individual and vary the length of the element for fit.

The sizing matrix presented here offers a fit to a wider range of subject sizes by varying both cross sections and lengths of selected elements.

Anthropometric data from several sources has been utilized to define the sizes for each pressure garment element. The 5th to 95th percentile range of each group was selected as the range that should be covered by the modular sizing matrix.

SIZING CONSIDERATIONS

Definition of a rational modular sizing system is based on selected anthropometric measurement for each modular element. Data from several sources has been extracted to define the ranges needed in each sized element. It should be noted that because of inconsistencies in the types of measurements taken in different surveys, not all measurements required for this sizing study were available. In most cases, the missing data has been projected by simple regression equations based on stature.

ORIGINAL PAGE IS
OF POOR QUALITY

208



- o BI-MODAL DISTRIBUTION OF MALE AND FEMALE POPLATION COMPLICATES MODULAR SIZING SYSTEM
 - FEASIBLE MODULAR SIZING SYSTEM PROPOSED
 - TWO RANGES OF CIRCUMFERENTIAL SIZING COMPONENTS
 - INTERMEDIATE LENGTH INSERTS

o MORE STRINGENT SELECTION OF ASTRONAUT COULD SIGNIFICANTLY AFFECT SYSTEM COSTS

SIZING CRITERION: BIACROMIAL BREADTH

209

1977 FEMALE ASTRONAUT
 1979 FEMALE ASTRONAUT
 1985 FEMALE
 1977 MALE ASTRONAUT
 1979 MALE ASTRONAUT
 1985 MALE
 HUT SIZING

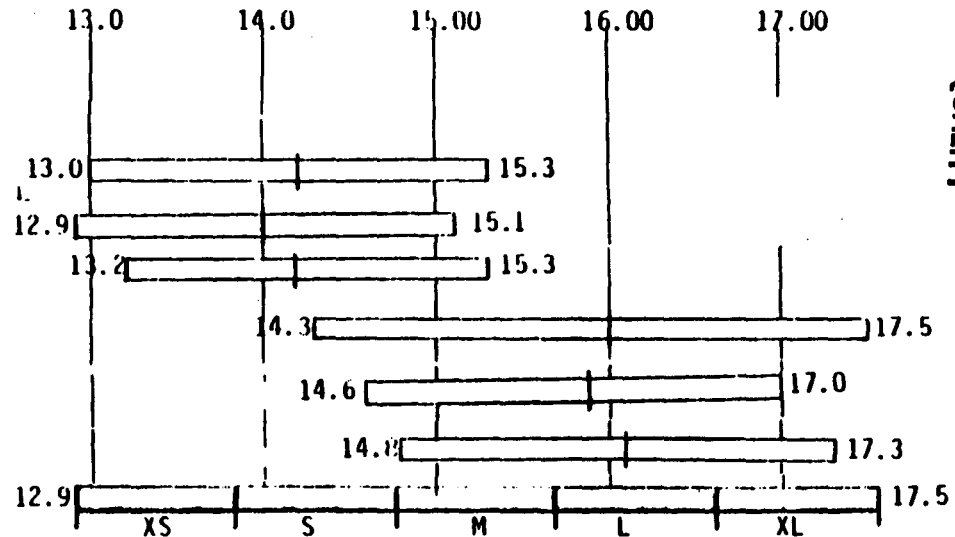

ORIGINAL PAGE IS OF POOR QUALITY

SIZING CONSIDERATIONS (cont'd)

NASA Reference Publication 1024 provides projections for measurements of 1985 males based on population growth curves. Similar data is provided as 1985 female measurements. However, due to lack of data on growth curves of the female Air Force population, the information provided is an estimate based on the officer sub-series from Anthropometry of Air Force Women by Clauser, et. al.

Since it seems reasonable to assume that the female population will undergo the same rate of growth as the male, we have prepared projections for the 1985 female based on the 1968 Air Force data and assuming the same growth rate in weight and stature as that projected for men. Other measurements for 1985 females were then derived by multiple regression equations.

Data derived from male Air Force flight personnel are skewed by preselection due to screening during earlier selections. The data on Air Force women while also skewed by preselection is probably less so since it does not represent flight personnel only.

As the selection of workers for long term construction and maintenance tasks in orbit takes place, it is possible that both male and female candidates will cover a wider range of measurements than the current data allows. The sizing matrix can be enlarged or shifted for certain measurements, but there will be limits to the sizes of subjects that it is possible to fit. Once the sizing matrix is established it may be necessary to select EVA worker candidates who fit within the measurements defined. The production and inventory costs of fitting a nonconforming subject would be extremely high.



NASA

ADVANCED EMU ANTHROPOMETRICS

LOCKHEED

ELEMENT: UPPER ARM
 FOREARM
 TORSO LENGTH
 UPPER LEG
 LOWER LEG
 FOOT LENGTH

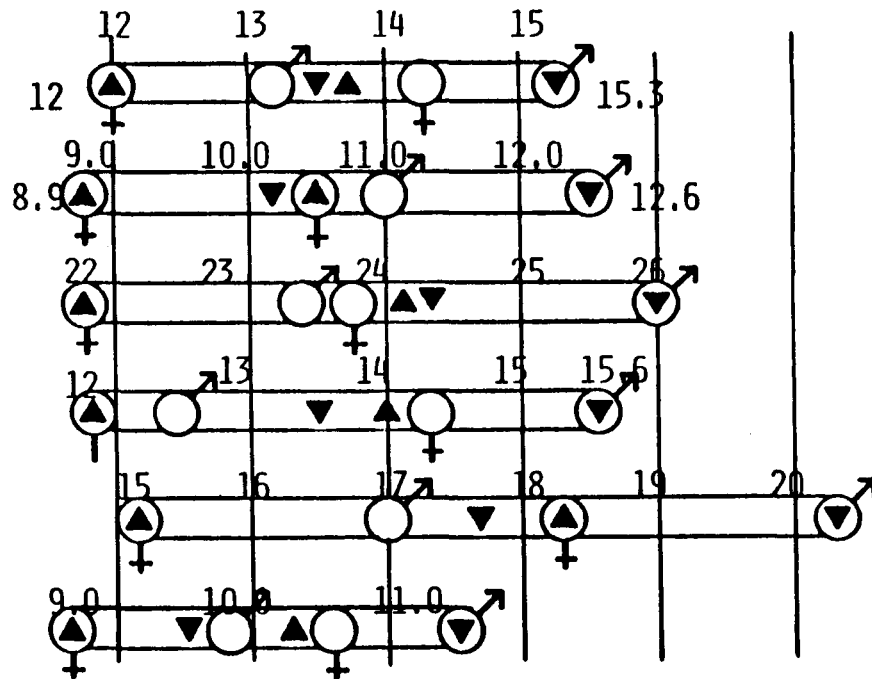

LEGEND

- FEMALE LIMITS
- MALE LIMITS
- SMALL MODULE RANGE
- LARGE MODULE RANGE

ORIGINAL PAGE IS
OF POOR QUALITY

211



NEW TECHNOLOGY ENVISIONED SORTIE

EVA tasks, both planned and contingent, would be greatly enhanced by the suggested EMU. Modular yet reliable, and having a design goal of ten operational cycles, this unit would provide a means of mobile protection for several crewmembers on rotating shifts.

Two of the proposed EMUs would service four crewmembers working sequential six-hour shifts. Upon completion of their six-hour sortie, the first team would return to the ship, go through any required decontamination procedures, and doff the unit. The EMU would quickly and easily break down for cleaning and/or resizing. Each element of the EMU would have an identifier so that a computer log could be kept on component use rather than total suit life. The total sortie time and task would be logged in for the unit being worn. The computer would then automatically record wear values for each element of the total EMU. This would allow extended life items to be used to their fullest capacity. Additional front and back identification would be provided for those segments of the suit that are constructed in a toroidal joint configuration. After each sortie, these joints would be rotated 180° so that the front would then become the back and vice versa, thus maximizing their useful life. Using the computer log system, any wear trends which might develop would be quickly discovered and brought to the attention of the design department for corrective action. It is envisioned that a complete resizing, donning, and donned check-out could be performed within a period of forty minutes. With man-induced loads associated with occupancy of the EMU, a pressure slightly higher than normal test pressure should be used prior to EVA.

The high reliability built into the EMU limits the amount of required in-orbit maintenance. Outside of normal freshening of the garment, maintenance tasks consist of lubricating bearings and sealing gaskets, visual inspection, and some limited testing.

More extensive testing performed on a periodic (six-month) basis would be handled by maintenance crews stationed on earth. Bearings and bearing races would be torn down, cleaned, soft goods replaced, reassembled, and evaluated. X-ray examination of hardware and rigid structures would be one means of determining their relative repair status. Upon evaluation, the element would either be returned to service in orbit, or retained on earth for training purposes. All elements not meeting the evaluation criteria would be scrapped.



ADVANCED EMU EQUIPMENT TURNAROUND

NASA

LOCKHEED

- o EXTENDED MODULARITY LONG LIFE COMPONENTS YIELD
 - MINIMUM NUMBER OF EMU COMPONENTS IN ORBIT
 - EASE OF COMPONENT INSPECTION/REPLACEMENT
- o COMPUTER AIDED IN-ORBIT COMPONENT MAINTENANCE AND EMU ASSIGNMENT
 - EARTH MAINTENANCE AND ASSIGNMENT OF COMPONENTS
 - FAILURE/TROUBLE STATISTICS AND FLAGGING OF MARGINAL ELEMENTS

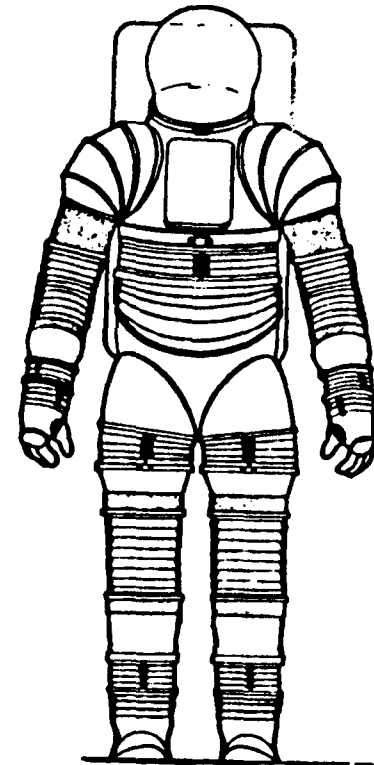

ORIGINAL PAGE IS
OF POOR QUALITY

213





- 0 ADVANCED EMU UTILIZES AVAILABLE TECHNOLOGY
 - RADIATION--MINIMUM IMPACT ON DESIGN FOR LEO
 - GEO NOT ADDRESSED
 - OPERATIONAL PRESSURE--~~28~~ PSI MIXED GAS
 - MOBILITY EFFECTS--FULL MOBILITY, LOW TORQUE
 - TOOL/GLOVE/EFFECTOR--MODULAR GLOVE FOR LEO
 - EFFECTOR PRESSURE VESSEL FOR GEO
 - MODULAR POWER TOOL INTERFACE
 - ANTHROPOMETRICS--BI-MODAL EXTENDED MODULARITY SYSTEM
 - EVA LIGHTING--SERVOED INTENSITY AND ARTICULATION FOR FILL-IN LIGHTING
 - EQUIPMENT TURNAROUND--MODULAR COMPONENT BUILD UP IN ORBIT
 - COMPUTER AIDED TRACKING AND TROUBLE IDENTIFICATION

214

ORIGINAL PAGE IS
OF POOR QUALITY



11186

PAYLOAD IVA TRAINING AND SIMULATION

James H. Monsees

Crew Systems (62-91)
Space Systems Division
LMSC

215

LOCKHEED MISSILES & SPACE COMPANY. INC.

PAYLOAD IVA TRAINING AND SIMULATION

James H. Monsees, Orgn 62-91
LMSC, Sunnyvale, California

ABSTRACT

Training activities for the payload are the only Space Shuttle flight courses which are not the responsibility of NASA*. Payload training is conducted by the payload developer. Lockheed, in this role, has implemented a training development methodology, in support of its payloads, which is economical to the program while fulfilling the contractual requirements. The major points of this paper describe Lockheed's training and simulation development approach and contrast them with both the NASA and the Instructional Systems Development approaches, to illustrate how economics are achieved.

* Excluding those NASA payloads developed 'in-house'.

Challenges of Payload Training Development

Payload IVA training programs present some unique challenges to the contractor. These tend to make the development of payload training relatively expensive proposition. The four primary "unique" characteristics and the methods Lockheed is using to meet the challenges they present are discussed below. They include (1) compliance with established training standards, (2) meeting varied needs, (3) maintaining security, and (4) accommodating changes.

Compliance With Established Standards

An initial consideration is that as the contractor, Lockheed, is developing training for a clientele with very regimented procedures, operations languages, and document

formats. Payload training development teams must be familiar with NASA documentation and the customer's preference (Military specifications, Military standards, etc.) to insure development of acceptable training programs. The key to cost reduction is for the contractor to be close to 'on target' with the early iterations of the training plan and the first package of training materials.

Meeting Varied Needs

The Payload training programs are designed to familiarize all of the responsible crew members with Space Shuttle payloads. All of the personnel who must become familiar with the payload's characteristics, payload operations, and the materials equipment and aides associated with those operations will be taught by the contractor. While the training is intended for the Payload Specialist, since he is the primary operator, the courses must be given also to Payload Operations Control Center (POCC) ground crews, NASA ground crews, and the NASA flight crew, to meet their specific needs. Typically, while the Payload Specialist operates the payloads from the aft flight deck, the Mission Specialist is his IVA back-up, the pilot provides EVA support, the commander and pilot position the Orbiter and use the RMS to support payload operations and the ground crews execute commands and monitor crew activities and payload status. The instruction associated with payloads, then must be packaged in several ways to meet the varied needs. The challenge to the contractor, attempting to compete in the payloads market place, is to develop the fewest programs possible for meeting everyone's needs.

Maintaining Security

Another unique characteristic of payloads is that some of them must be built, tested and operated in secrecy. Classified payload training imposes many constraints on the contractor as the training developer, and on all of the personnel who are to be

trained. Payload courses which are classified must handle and control classified materials, provide secure training facilities and secure simulation interfaces. Obviously, classified training is a cost driver, but costs can be controlled through a mature security program. The primary planning factor which is impacted by classified training courses is response time. Because of the requirements for all program participants, written materials and training aids to be controlled, there is a slow-down effect on requirements analysis, course development, and course implementation and revision.

Accommodating Change

A second characteristic of payload training programs, in contrast to the NASA Space Shuttle flight programs, is that the hardware and the operations tend to be uniquely different for each payload. There is very little "generic" training in the payload curriculum. A second challenge, then, is to continue to develop totally new programs, while maintaining quality in the curriculum.

LMSC Approach to Payload Training Challenges

The training development responsibility for each Lockheed payload falls on each specific program office. The Program Training Manager staffs his training group as efficiently as possible. The manager usually calls upon LMSC's Space System Division's Crew Systems organization for providing an experienced Space Shuttle interface team.

The Crew Systems group employs a variety of disciplines, which interface with program engineers at various stages of program development. Figure 1 gives a breakdown of the LMSC Crew Systems group and highlights the relationship to training and simulation for each program. This approach of manning the program

with a Shuttle oriented group, assures that a body of experience will be available to each new program.

The Program Training Manager uses the Crew Systems personnel (who have usually been involved in program proposals) to interpret both NASA and military standards and specifications, to review standard NASA and Ground Crew operating procedures and to assist in or lead the development of specific modules of the training program. The availability of a body of personnel who are experienced in Shuttle Payload development is invaluable in the efficient production of new training programs.

A vital element of new payload training program development is interface planning. Lockheed has established three levels of working groups to insure this interface. The working groups, as shown in Figure 2 consist of the Crew Training Committee (CTC), the Crew Activities Working Group (CAWG) and the Payload Operations Working Group (POWG). The CTC is an in-program group consisting of writers and instructors, which regularly integrates training and simulation development activities. The CAWG is an LMSC wide group which interfaces the Program Training Manager with course writers, editors, artists, and security personnel. This group meets to coordinate the production, evaluate and distribute course materials.

The POWG is an interface group in which the developers and all of the users have opportunity to review objectives and status of the payload training program throughout their stages of development. The employment of planned interfaces with all personnel involved significantly reduces the amount of time lost in pursuing invalid requirements.

ORIGINAL PAGE IS
OF POOR QUALITY.

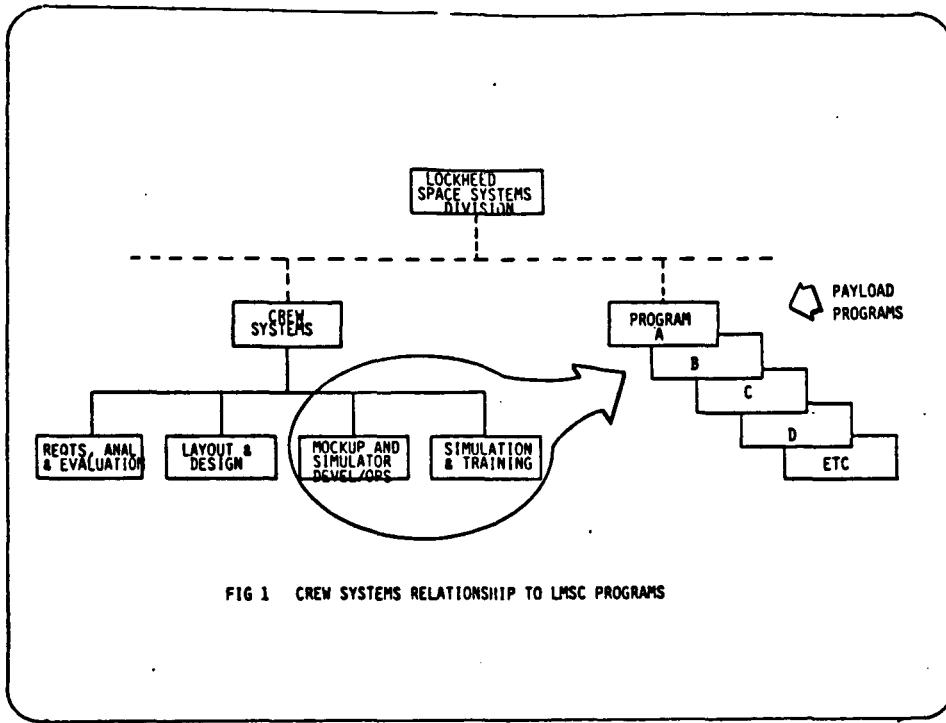

FIG 1 CREW SYSTEMS RELATIONSHIP TO LMSC PROGRAMS

FIG 2 WORKING GROUPS ESTABLISH VITAL INTERFACES

CREW TRAINING COMMITTEE (CTC)	CREW ACTIVITIES WORKING GROUP (CAWG)	PAYLOAD OPERATIONS WORKING GROUP (POWG)
JPO (Status review)	JPO (Status review)	JPO (Status review)
P/L TRNG MANAGER	P/L TRNG MANAGER	NASA
COURSE WRITERS	COURSE WRITERS	EXPERIMENTERS
INSTRUCTORS	INSTRUCTOR	P/L TRNG MANAGER
	EDITOR	
	ARTIST	
	PUBLISHER	
	SECURITY	

Meeting Varied Needs

Several actions are taken to make training programs meet the needs of all the personnel involved, while keeping costs to a minimum. The tasks of all payload operations personnel are analyzed; a program which meets the most stringent needs (those of the Payload Specialist) is developed, and a simple tailoring strategy (for other personnel's training) is devised and implemented.

The multi-level task analysis of all ground or flight positions is essential. It provides scope for the training developers. The data for most of the analyses are found in the program proposal, the training plan and PIP annexes.

The analysis can be multi-level, in contrast to ISD methodology which insists upon rigorous task analysis for all tasks. Tasks which are understood and for which training is straight-forward receives no more than a simple inventory. On the contrary, critical tasks which are new, such as for example, IVA-EVA coordination of a manual-override operation, undergo task-timelining in detail.

Training is developed using a moderately complicated Payload Specialist scenario, which exercises all payload interfaces in the aft flight deck. The development assures that the Payload Specialist understands his mission, all of his interfaces, his equipment and the payload dedicated hardware. He experiences three stages of training: information, part-task (hands-on), and rehearsals.

Training for other personnel is usually based extensively on the Payload Specialists program. The cost effectiveness concern emphasizes the need for very minimal changing of the core training program. In a recent payload training program, hands-on training was deleted from the ground crew courses and instructors modified their

FIG 3 COURSE DEVELOPMENT (EXAMPLE)

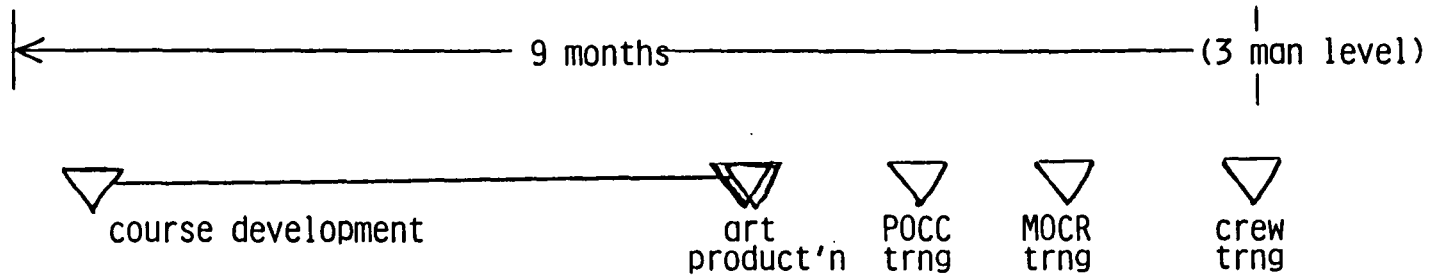

- Overview
- P/L-Experiment Description
- Mission Planning and Timelines
- Aft Flight Panel--P/L Interface
- Payload Flight Data File
- Crew Equipment
- Course Review, Q&A

222
7

ORIGINAL PAGE IS
OF POOR QUALITY

presentations to provide details or overviews, based on what the different groups required. Figure 3 summarizes the recent payload course development approach.

As a final step in keeping costs down, Lockheed has innovatively developed an approach to reduce dedicated, hard training materials. That is, no texts, no films, videotapes nor workbooks are developed specifically for payload training. The only dedicated training products for the most recently developed course were a training plan and viewfoils. The comprehensive training plan contains the course and lesson objectives providing consistent direction for the course development. The training viewfoils were used to guide the instructors and were used as handouts.

Maintaining Security

Security is a crucial concern for payload training developers. Security, which is required for program training personnel, documentation, facilities and communications interfaces increases the cost of payload training programs.

Lockheed classified programs use, in addition to internal personnel, personnel from the editing staff who maintain program clearances. This editing staff interfaces with the course production support functions such as artists, publishers, and photographers. These editors are the primary interface between the draft course materials input by the course writers and secure production support facilities. They, as well as the program course developers (writers) are familiar with the security constraints on the materials developed. LMSC has learned that it is essential to use checklists to insure that security provisions are included on the materials, that is that they are appropriately stamped, given document numbers and are controlled. Also, forms are used to pass course materials on its support functions for completion and to return

them to the course writers. Close tracking of security details is essential to prevent a time loss due to misplaced pages or improperly marked course materials.

Secure facilities are provided at LMSC for classroom training and for hands-on operation. Economy is achieved through the multi-purpose and multi-program use of common facilities. In a later paragraph, the Advanced Vehicle System SATLAB is described. It is one example of a secure training facility.

For future program requirements, there is a need to employ secure communications for integrated training and simulation. These resources are in existence at Lockheed but are not currently used for Space Shuttle payload training.

Accommodating Changes

Since payloads for each program tend to be significantly different from one another, the training courses themselves require unique efforts. The most effective way to control training development costs has been to use experienced personnel, who maintain source documents and lessons learned documentation and are familiar with using reconfigurable simulation capabilities. Using this approach, the need to reinvent is minimized.

Source documents for course development are maintained in data banks and readily accessible to program course development personnel. Where experienced personnel can short-cut analysis and training development time by using documentation from previous efforts, this documentation is normally used as a starting point. Source documents and lessons learned are a particularly valuable resource.

Payload systems are rather complex and tend to be somewhat unstable until the final stages of payload development. Lockheed has found that engineers who have skill in presenting briefings are readily convertible into instructors and are well informed on their subjects, due to their continuous involvement with the payload. A cost reduction is achieved by eliminating the time required to train an instructor to be totally conversant with spacecraft systems.

Reconfigurable Simulation

Lockheed uses the AVS SATLAB, mentioned earlier, as a hands-on Payload Specialist procedures trainer, Figure 4. The SATLAB, therefore, is a vital element in Payload Specialist training. The SATLAB layout is shown in Figure 5. A secure training facility, the SATLAB supports many aft flight deck requirements, including Payload Specialist training. Payload Specialist requirements involve using interactive monitoring/command panels. Use of the panel is normally moderated through training scenarios: and it is operated only as directed by the payload flight data file Orbit Operations Checklist. Since visual feedback of the payload is required, video monitors are positioned at the aft flight deck windows.

To assure a cost-effective, low risk implementation of the SATLAB, LMSC is using an incremental development approach. The increments were planned in four stages, each determined by payload program requirements and program funding.

The first stage uses actual flight Payload Specialist panels, and connects the panels to the payload through hardwire cables. Also closed circuit TV is used to show payload status visually.

The second stage implements a computer simulation of the payload. The simulation provides Payload Specialist panel malfunction indications; a capability which is generally not available using the actual payload.

The third stage incorporates computer Image Generation of outside visual scenes incorporating a low-cost four window system. At this stage the orbiter attitude ephemeris and trajectory are modifiable.

The final stage of development involves including the RMS, if and when that becomes an associated Payload Specialist responsibility.

Figure 6 shows the development stages of the SATLAB and some of the support programs which are driving the phased development.

Conclusion

STS payload training at LMSC is still in its nascent stages. However, the continuing growth of the Space Shuttle payload manifest, the growing involvement of man-in-the-loop and Lockheed management's commitment to support payload IVA training indicate that Lockheed's training development programs will grow in parallel with the shuttle payload program.

Through the aforementioned training approach techniques, Lockheed has been able to reduce the overall 'classic' training program cost some 2 to 4 times from what was experienced previously. Thus, this realized saving can be passed on to the customer as a substantial cost reduction - so important in the overall responsibility of the contractor in support of STS payload development.

FIG 6 AFT FLIGHT DECK ENHANCEMENT STAGES

CAPABILITIES STAGE NO. TYPE P/L SUPPORT	CONTROL/ COMMAND PANELS	MISSION VIDEO	INSTRUCTOR OPERATOR STATION	SSV DYNAMIC CONTROL (AFD)	POTENTIAL PAYLOADS	EXISTING LMSC SIMUL S/W
STAGE 1 • control and monitor of normal ops	• actual panel driven by p/l in proximity	• cctv of payload in proximity	• communication • ref. time	none	• P-380	N/A
STAGE 2 • response to p/l malfunc'ts • no schedule limitations • experiments with panel configurations	• generic AFD panel • generic p/l simulation	• SAME	• SAME • simulation control • mal. insert	none	• LMSC R&D • engin'rg analysis	• SIMSCRIPT • GASP IV E
STAGE 3 • control orb attitude (no motion base) • scene gen.	• SAME	• scene generation	• Integrated IOS, AFD to STC & DSM	• AFD attitude control	• ESS II	• SAMSON • SHUTLE • DRAW P/L
STAGE 4 • deploy and berth • acquis'tn and tracking	• rapid re-configuration of p/l, panel • acq. and trk.	• deployables • intercept spacecraft	• performance measurement	• RMS control • capture • berth	• sp telesc • pgm B • pgm C • pgm D • non-LMSC payloads	• DOCK • PDRS • MULTI-BODY

228
13

ORIGINAL PAGE IS
OF POOR QUALITY

ORIGINAL PAGE IS
OF POOR QUALITY

1188 11187

SPACECRAFT
REDUNDANCY AND
ENVIRONMENTAL TESTS
AN HISTORIC EVALUATION

BY
V. S. BOLLMAN
AND
R. A. BLOCKINGER

APRIL 30, 1982

LOCKHEED MISSILES & SPACE CO., INC.

PRESENTATION AT THE SATELLITE SERVICES WORKSHOP
JUNE 22, 23, 24, 1982
NASA JOHNSON SPACE CENTER

229

8811 3841

PREWORD

This study originated because concern was expressed by government space system planners that the potential capabilities of the space shuttle may not be fully exploited in future space systems.

These space shuttle capabilities are expected to provide the following:

1. On-orbit mating of components, subassemblies and assemblies.
2. Satellite retrieval and return to earth.
3. On-orbit satellite check-out, repair, refueling and testing.

Because the shuttle has these capabilities it was postulated that reliability and test requirements might be reduced for the entire acquisition cycle for spacecraft.

The original paper was given at the Sixth Aerospace Testing Seminar at Los Angeles on March 11 - 13, 1981, and covered spacecraft designed built and tested by LMSC and flown using expendable launch vehicles over a ten-year period through 1978. Today's paper is an update and an abbreviated summary of that earlier paper. It covers additional history through 1981.

PURPOSE

The purpose of the study is to answer the following questions:

1. In the shuttle era, is it necessary and cost effective to provide highly redundant spacecraft since they can be retrieved from orbit?
2. Are extremely extensive environmental tests still necessary at the system level?

The experience of LMSC's many spacecraft over a 12-year historical period can be extremely useful in providing data to help assess the value of redundancy and systems test programs.

BASIS OF STUDY

The study analyzed the history of 67 spacecraft over a 12-year period. Each of these were looked at in two different ways. For each spacecraft the following assumptions were made:

1. Redundancies but no environmental system acceptance testing. The study estimated what the duration of spaceflight operating time would have been without environmental system testing but with the redundancies of the actual spacecraft.
2. Environmental systems acceptance testing but no redundancies. The study estimated the duration of spaceflight operating days with the systems environmental test performed but with the assumption that all redundancies had been removed.

TESTING PROGRAM

Each of the spacecraft reviewed were subjected to comprehensive system environmental acceptance tests in accordance with MIL-STD-1540 as amended by contractual documents. A typical sequence is as follows:

1. Serial System Test (verify component capability)
2. Baseline integration
3. EMC
4. Functional
5. Acoustic
6. Functional
7. Pyro shock
8. Functional
9. Mechanical Release Systems check
10. Functional
11. Pressure leak
12. Functional
13. Booster compatibility
14. Functional
15. Weight and CG
16. Alignment
17. Functional
18. Thermal Vacuum Cycling
 - 2 temperature cycles minimum at +10⁰F to +100⁰F in a vacuum, 10⁻⁵ Torr.
 - First 4 days, thermal balance
 - (a) Verify equipment thermal design
 - (b) Verify analytical thermal models
 - (c) Verify heating and cooling system performance margins for hot and cold extremes for both primary and back-up circuits.

19. Functional
20. Antenna deployment
21. Final functional
22. Mechanical preparations
23. Confidence tests
24. Shipping preparations
25. Ship

NOTE: During thermal vacuum testing redundant equipment is exercised separately (an together if applicable), and, components are not allowed to exceed acceptance test temperature levels.

In addition to the system tests, each component received an acceptance test prior to being installed in the spacecraft. A typical test sequence is as follows:

1. Functional
2. Random vibration (3 axes)
3. Functional
4. Thermal vacuum cycling (5 cycles, 75 hours) at -10°F to $+140^{\circ}\text{F}$
5. Functional
6. Leak
7. Functional
8. Burn-in thermal cycling (30 cycles, 330 hours) at -10°F to $+140^{\circ}\text{F}$
9. Final functional

Ground Rules of Study (See typical methodology chart)

Case 1. Redundancy but no environmental testing. Each spacecraft history was reviewed to determine the number of days in system environmental acceptance testing until a critical equipment repetitive failure occurred. (Ambient system test operating time was not counted because we assumed it would be done even if no environmental testing were performed). If no second failure occurred in system test the spaceflight operating time was counted up to the second failure.

Case 2. Environmental testing but no redundancies. Each spacecraft operating history was reviewed to determine the point at which the first mission critical failure occurred on a redundant pair. The number of successful spacecraft operating days would have ended at this time if no redundancy was aboard.

CONCLUSIONS

Significant reductions in the number of achieved days would have occurred without system testing or redundancies. The following is tabular summary:

67 SPACECRAFT	CUMULATIVE TOTALS
ACHIEVED DAYS	29,270 ACTUAL
REDUNDANCY ONLY (NO ENVIRONMENTAL TESTING)	5,584 EST.
ENVIRONMENTAL TESTING ONLY (NO REDUNDANCY)	8,812 EST.
TOTAL SYSTEM FAILURES	357
TOTAL FLIGHT FAILURES	119

From the above it can be concluded that--

1. Spacecraft with the same redundancies as used in the past, but eliminating systems environmental acceptance testing would have to be delivered at 19% of the current cost to provide the same effective on-orbit days.
2. Spacecraft without redundancies, but subjected to the current systems environmental acceptance testing would have to be delivered at 30% of the current cost to provide the same effective on-orbit days.
3. Environmental testing appears to be more effective than redundancy in increasing on-orbit mission days.
4. The present practices of providing redundancy of critical components and environmentally testing the spacecraft are cost effective and should be continued into the shuttle era.
5. 357 potential on-orbit failures which could have been mission critical were detected during systems environmental acceptance testing.
6. In the shuttle era, these spacecraft would need to be retrieved for repair 3 to 5 times more often if they did not have redundancy or system environmental testing. This would be a significant economic impact in addition to the potential mission time value loss that cannot be estimated in dollars.

The final result of this study is that LMSC is convinced of the significant value of redundancy in spacecraft and systems environmental testing and such techniques should be carried forward into the shuttle era.

ORIGINAL PAGE IS
OF POOR QUALITY

234

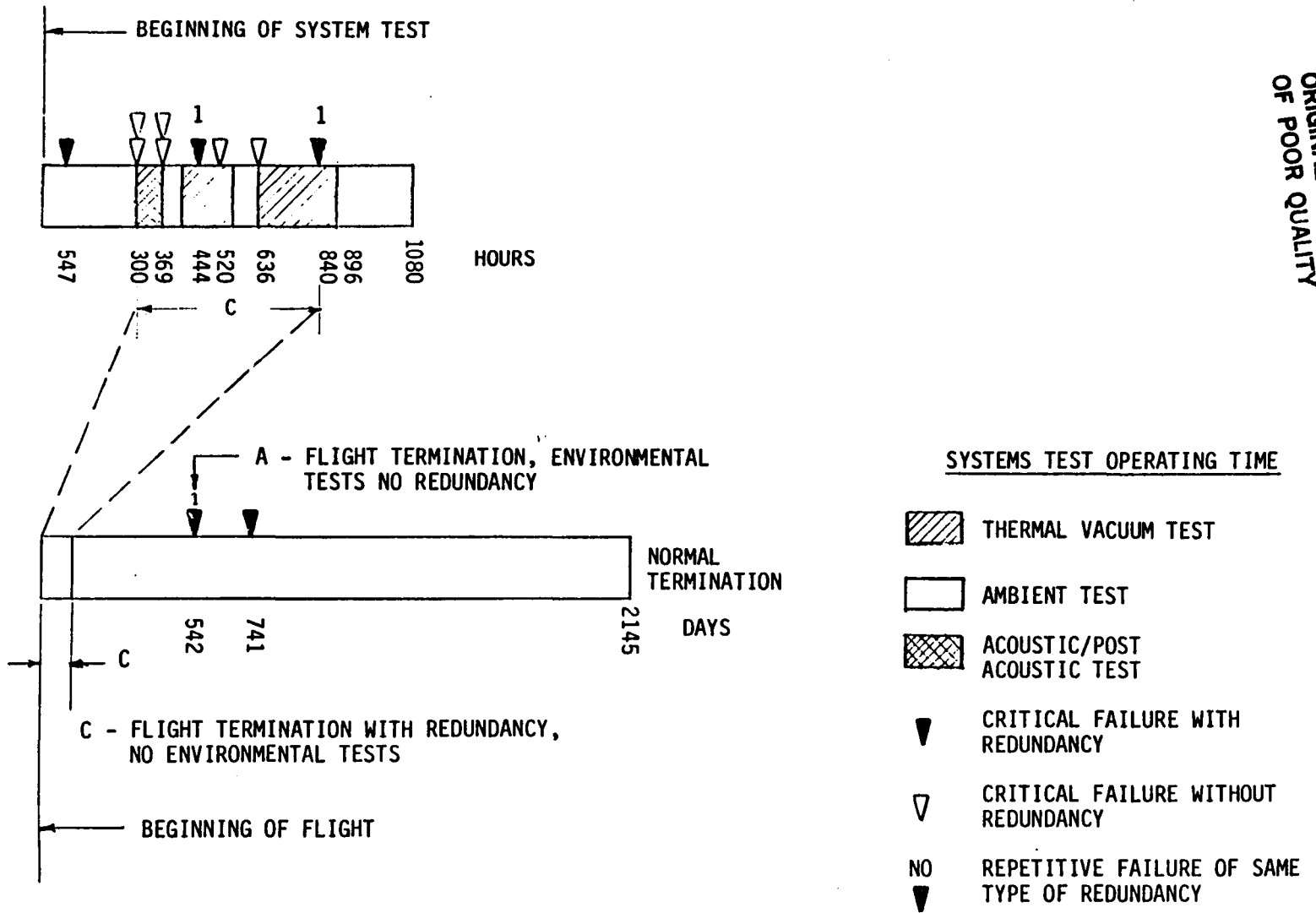

REDUNDANCY
AND
ENVIRONMENTAL TESTS
AN HISTORIC EVALUATION

235

ORIGINAL PAGE IS
OF POOR QUALITY

BY V. S. BOLLMAN
AND R. A. BLOCKINGER

DATA BASE

- ANALYZED SYSTEMS TEST AND FLIGHT DATA FOR SIX PROGRAMS TOTALING 67 SPACECRAFT OVER A 12 YEAR PERIOD
- ANALYZED SYSTEM TEST FAILURE DATA AND DETERMINED SYSTEMS TEST OPERATING HOURS
- ACCUMULATED A TOTAL OF 29,270 FLIGHT OPERATING DAYS (80 SPACECRAFT YEARS)

REFERENCE: PROCEEDINGS - INSTITUTE OF ENVIRONMENTAL SCIENCES, SIXTH AEROSPACE TESTING SEMINAR, 11-13 MARCH, 1981

PURPOSE OF STUDY

- EVALUATE VALUE OF REDUNDANCY

- EVALUATE NECESSITY FOR SYSTEM ENVIRONMENTAL TESTS

- DETERMINE: IS ELIMINATION OF REDUNDANCY OR SYSTEM ENVIRONMENTAL TESTING A SOUND, COST-EFFECTIVE MEASURE ?

237

ORIGINAL PAGE IS
OF POOR QUALITY

ACCEPTANCE TEST REQS

PARTS

- ACTIVE: JANTXV AND CLASS B SCREENING OR BETTER
- PASSIVE: E-REL SCREENING

BOXES (LATER BOXES RECEIVED MORE TEMP CYCLES & BURN-IN)

- VIBRATION: RANDOM, 3 AXIS
- THERMAL VACUUM: 1 TO 15 CYCLES
- BURN-IN: HI TEMP, 100 TO 500 HRS,
LAST 100 HRS FAILURE FREE

ALL ITEMS PREVIOUSLY QUALIFIED AT HIGHER ENVIRONMENTAL LEVELS

ORIGINAL PAGE IS
OF POOR QUALITY

SYSTEM TEST

<u>PROGRAM</u>	<u>ACOUSTIC</u>	<u>PYRO DEPLOY</u>	<u>HI PRESS.</u>	<u>T/V (MINIMUM)</u>
A	1M		X	32H 2~
B	1M	X	X	X
C	X	X	X	200H 6~
D	2M		X	20D 8~
E	1M	X	X	7D
F	1.5M	X	X	14D

D = DAYS
M = MINUTES
H = HOURS
~ = CYCLES

ORIGINAL PAGE IS
OF POOR QUALITY

239

SYSTEM TEST DATA GUIDELINES

FUNCTIONAL FAILURES ONLY ELIMINATED FROM DATA BASE:

- TEST FAILURES TRACED TO TEST EQUIPMENT
- TEST FAILURES TRACED TO PROCEDURES
- TEST FAILURES TRACED TO HUMAN ERROR
- NON-CRITICAL EQUIPMENT FAILURES
- UNVERIFIED FAILURES
- DEGRADING/NON-CATASTROPHIC FAILURES
- HYDRAULIC/PNEUMATIC LEAKS

ACCOUNTABLE FAILURES:

- ALL OTHERS

246

ORIGINAL PAGE
OF POOR QUALITY

BASIS FOR REDUNDANCY/TEST RATIONALE

CASE 1: REDUNDANCY BUT NO ENVIRONMENTAL TESTING

- A. THE NUMBER OF DAYS IN SYSTEM TEST UNTIL A CRITICAL EQUIPMENT REPETITIVE FAILURE OCCURRED
- B. IF NO REPETITIVE FAILURES OCCURRED DURING SYSTEM TEST, CONTINUED THE SEARCH INTO THE FLIGHT PERIOD

CASE 2: ENVIRONMENTAL TESTS BUT NO REDUNDANCY

THE NUMBER OF SPACE FLIGHT DAYS BEFORE THE FIRST REDUNDANT EQUIPMENT FAILURE OCCURRED.

NOTE: SINGLE REDUNDANCY (ONE BACKUP BOX) ONLY WAS EVALUATED. IN ACTUAL PRACTICE, SOME EQUIPMENTS HAVE MULTIPLE BACKUPS.

24)

ORIGINAL PAGE IS
OF POOR QUALITY

242

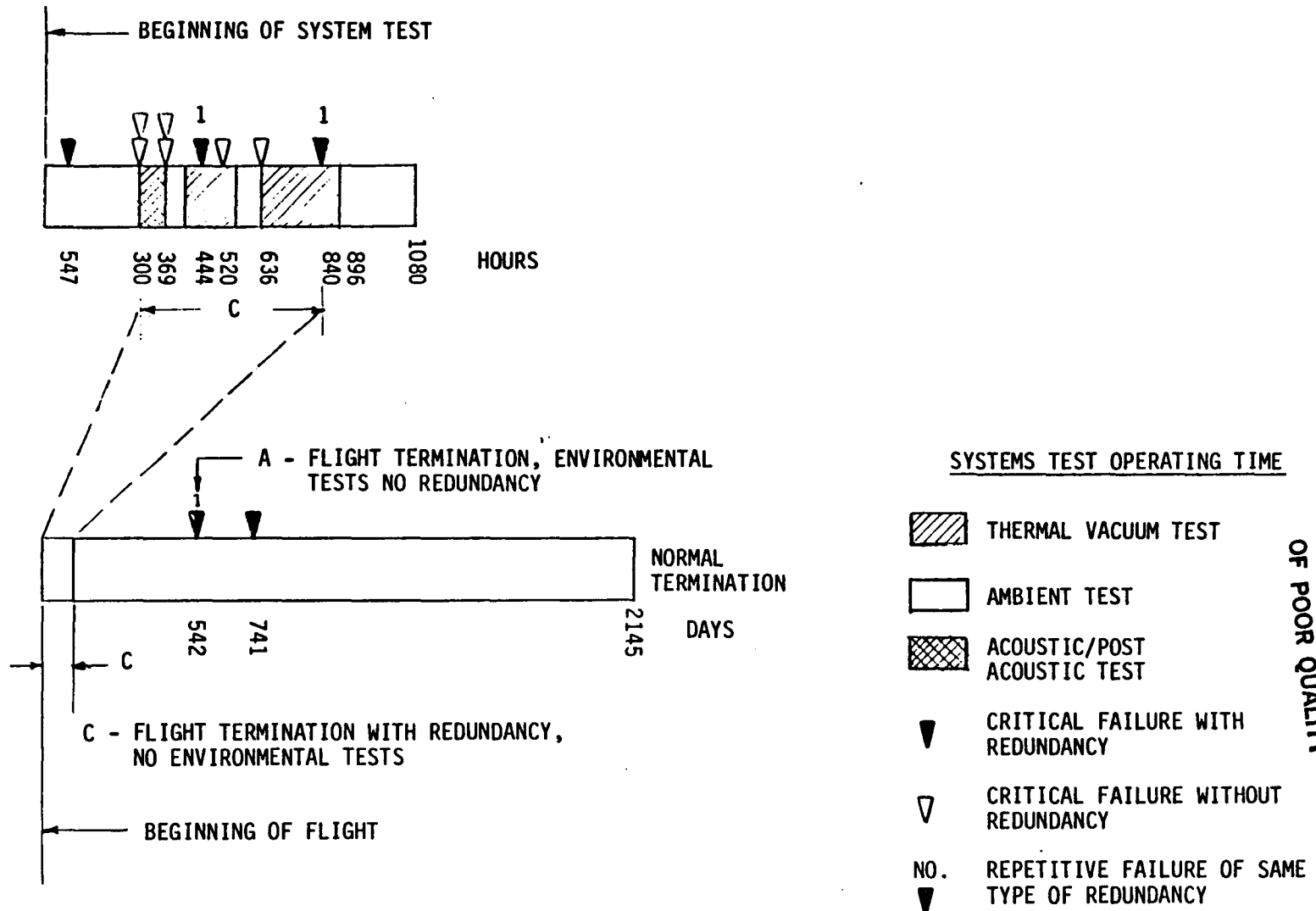

ORIGINAL PAGE 19
OF POOR QUALITY

SUMMARY OF STUDY RESULTS

S/C OPERATING DAYS THAT WOULD HAVE BEEN
ACHIEVED UNDER THE ASSUMED CONDITIONS

	<u>DAYS</u>
ASSUMPTION	
◦ REDUNDANCY BUT NO SYSTEM ENVIRONMENTAL TESTS	5,584
◦ ENVIRONMENTAL TESTING BUT NO REDUNDANCY	8,812
ACTUAL LENGTH OF S/C OPERATING TIME	29,270
TOTAL NUMBER OF SYSTEM TEST FAILURES	357
TOTAL NUMBER OF FLIGHT FAILURES	119

243

ORIGINAL PAGE IS
OF POOR QUALITY

ON-ORBIT TIME RATIOS

$$\text{REDUNDANCY, NO ENVIRONMENTAL TEST} = \frac{5584}{29,270} = 19\%$$

$$\text{ENVIRONMENTAL TEST, NO REDUNDANCY} = \frac{8,812}{29,270} = 30\%$$

244

ORIGINAL PAGE IS
OF POOR QUALITY

EFFECTIVENESS

$$\text{ENVIRONMENTAL TEST} = \frac{29,270}{5,584} = 5.24$$

$$\text{REDUNDANCY} = \frac{29,270}{8,812} = 3.32$$

$$\text{SYSTEM TEST EFFECTIVENESS} = \frac{357}{119 + 357} = 75\%$$

245

ORIGINAL PAGE IS
OF POOR QUALITY

CONCLUSIONS

THIS HISTORICAL EVALUATION HAS CONVINCED
LMSC OF THE SIGNIFICANT VALUE OF REDUNDANCY
IN S/C AND THE NEED FOR A RIGOROUS ENVIRON-
MENTAL SYSTEMS TEST.

IN THE SHUTTLE ERA, REDUNDANCY & SYSTEM
TESTING WILL EXTEND THE TIME BETWEEN
RETRIEVALS BY FACTORS OF 3 TO 5.

ORIGINAL PAGE IS
OF POOR QUALITY

246

L N 8 8 1 1 1 8 8

**ANALYSIS OF SATELLITE SERVICING
COST BENEFITS**

**HERBERT O. BUILTEMAN
ADVANCED SYSTEMS STAFF ENGINEER SENIOR
LOCKHEED MISSILES & SPACE COMPANY, INC**

JUNE 1982

ANALYSIS OF SATELLITE SERVICING COST BENEFITS

I INTRODUCTION

Projection of future costs depends very strongly on a series of assumptions, which must be carefully stated so that the conclusions are not endowed with more meaning than is justified. When the assumptions are clear the reader will be able to alter those that are inapplicable to his special set of circumstances and observe the results as tailored.

For the purposes of this paper, cost avoided in selecting one course of action over another is defined as "Cost Benefit." This paper addresses the methodology for preparing a cost benefit analysis pertinent to establishing the relative values of performing satellite servicing in various ways. It further applies the methodology to the benefits that could be realized by the user community in the timeframe of 1983 through 2005.

II SUMMARY AND CONCLUSIONS

Under the auspices of NASA/JSC a methodology was developed to estimate the value of satellite servicing to the user community. Time and funding precluded the development of an exhaustive computer model; instead, the concept of Design Reference Missions was involved. In this approach, three space programs were analyzed for various levels of servicing. The programs selected fall into broad categories which include 80 to 90% of the missions planned between now and the end of the century. Of necessity, the extrapolation of the three program analyses to the user community as a whole depends on an average mission model and equivalency projections.

The value of the estimated cost benefits based on this approach depends largely on how well the equivalency assumptions and the mission model match the real world. A careful definition of all assumptions permits the analysis to be extended to conditions beyond the scope of this study.

Currently "reasonable" assumptions reveal that on-orbit servicing of a space

resource, compared to the expendable spacecraft approach provides a positive cost avoidance. Of the various servicing modes, on-orbit refurbishment of a satellite is superior to returning it to earth for refurbishment and relaunch. It is also found that making use of a space station as a service base, where applicable, provides the greatest potential cost avoidance.

The study estimate indicates that on-orbit servicing can provide the user community with a potential cost avoidance of close to \$1.5 billion in 1982 dollars or \$13 billion in inflated current dollars in the period of 1983 through 2005.

III METHODOLOGY

The development of a logical progression of tasks is second in importance to the clear enunciation of consistent groundrules and assumptions. Figure 1 illustrates the steps established to guide the analysis of cost benefits pertaining to satellite servicing. The objective of the study was to estimate the total cost avoidance accruing to the space-user community through implementing on-orbit servicing of satellites. The first step in accomplishing this end was to define that user community. The Mission Model developed to provide such a definition was derived from two basic sources:

1. NASA STS Mission Model, JSC-13829, Oct 1977
2. STS Flight Assignment Baseline, JSC-13000-6, Mar 1980

The first of these is the most extensive, with a cutoff date of 1993 (after allowing for the STS schedule slip). Therefore, it was necessary to extend the model for cost analysis through extrapolation. Conservative annual traffic growths of 10 and 15% were used depending on the most recent published manifests.

In compiling the Mission Model the planned space programs were classified into four groups: 1. Low earth orbit (LEO); 2. sun synchronous orbits; 3. geosynchronous orbit (GEO); and 4. all others. The final classification was too diverse to be used in estimating the cost benefits. It is unrealistic to develop individual costs for each identified space mission. The approach used is to define a mission representative of each class and apply any cost benefit realized in analyzing that mission to the entire class. Thus, the second step

is to select the representatives or design reference missions (DRM's). The Space Telescope is a well known example of a LEO mission, though it is probably much more complex than the average LEO satellite in the Mission Model. This factor is taken into account by the normalization procedure explained below. It is also apparent that the detail planning of the actual program does not lend itself to generic comparative costing. For this reason certain liberties were taken with the Space Telescope in defining the LEO design reference mission. Figure 2 shows the parameters used.

For the Sun Synchronous class a hypothetical program representative of earth resources and certain DoD space programs was defined. Figure 3 presents the parameters for this design reference mission.

The GEO class is represented by a communications platform that is in the formative stages of planning. Figure 4 shows its parameters.

The third step in the analysis, as shown in Figure 1, is the definition of mission scenarios. These permit the costing of the service operations as well as the hardware involved. Four service scenarios are considered:

1. Expendable satellite, i.e., no service
2. Return to earth, refurbishment, and relaunch
3. On-orbit service performed from the STS Orbiter
4. On-orbit service performed from a manned space platform.

This completes the framework and the cost analysis proceeds for each of the design reference missions and for each of the applicable service scenarios. For all classes of missions the expendable case is considered the baseline against which cost avoidance will be judged. Once the gross program costs are determined, the option providing the maximum cost differential is selected as the optimum scenario for performing the mission. The avoided cost resulting from selecting a servicing option in preference to the expendable baseline is then "normalized" by computing a "Cost Avoidance Factor" which is simply the cost avoided per unit spacecraft mass per year of mission operation.

To apply these results to the user community as a whole, an average spacecraft mass and an average mission duration is selected. The kilogram years product is then multiplied by:

1. The population for the mission class in a given year
2. The fraction of the total population designed for service
3. The applicable Cost Avoidance Factor.

The output is a time-phased cost benefit.

To this point, constant year dollars have been used to express the cost benefits. The final step is to include projected inflation and present the results in "Then Year" dollars.

IV GROUND RULES, ASSUMPTIONS, AND MODELS

The need to reduce the analysis to a tractable level leads to some hard decisions on the assumptions to be accepted. Figure 5 enumerates those pertinent to this study. The term "sunk costs" refers to the expectation that the charges for the use of future NASA-developed space vehicles will be treated in the same way as are those of the STS. That is, the user will not be charged for the development of the vehicle but only for the recurring costs associated with its utilization.

A cost differential between expendable spacecraft and those designed for service is necessary to account for the man interface and mechanisms required to allow equipment changeout in orbit. The assumptions that the serviceable spacecraft development is 25% more and that production is 10% more than the cost of the expendable satellite are based on somewhat larger values for the Space Telescope program, adjusted for the expectation that as the state-of-the-art matures the cost differential will decrease.

The RCA "Price H" model was used to estimate parametrically the space vehicle costs. "Price L" was used to estimate the on-orbit maintenance tasks. EVA and other STS charges are derived from the NASA Space Transportation Cost Reimbursement Guide, 1980.

Figure 6 tabulates the cost elements evaluated for the various mission classes and the sources used in preparing the estimates. Other cost models are available and may be preferable for specific cases.

The RCA cost model "Price H" assesses the cost to develop and product space hardware against required schedules. It uses a weight-based set of cost-estimating relationships (CER's) and complexity of design factors as its infrastructure. It also includes a computation of integration cost.

The Price L" computes the cost of operations and maintenance support from the "Price H" files. It is capable of detailing the maintenance and spares policy based on input MTBF values.

The Richardson model computes the cost of facilities and site preparation based on a dollar-per-square-foot construction data base.

The fraction of the space-mission population that will be designed for service and, therefore, have planned service as part of the mission requiring costing is estimated in Figure 7. The minimum fraction is taken to be 10% and the growth is expected to be greatest for the low earth orbit missions reaching nearly 100% by the year 2000. The growth in the case of the sun synchronous missions is expected to be lower but approaching 70% by 2000. The added advantage of space-platform based servicing is expected to result in a higher growth rate for GEO satellites, but with their later start, 35% of the population is estimated to be serviceable at the end of the century.

The complete definition of the missions to be costed must include an accurate scenario. Figure 8 shows the events that make up the various options costed for the LEO missions. Figures 9 and 10 define the Sun Synch and GEO missions.

V ANALYSIS RESULTS

The total cost estimates for the three Design Reference Missions and their service scenarios are presented in Figure 11. In each case the cost avoided is the difference between the cost of the expendable spacecraft mission and the service option.

The cost-avoidance factors computed from the individual avoided costs are shown in Figure 12. This figure also defines the specific classes and scenarios analyzed in this study. Figure 13 plots the potential cost avoided for each type of mission vs time. The cumulative results for the three mission types are also plotted. This figure gives the results in constant 1982 dollars. The benefits returned by the GEO mission are seen to accrue starting in 1997, because the projected initial operating capability for both the OTV and the SOC is 1992 (and the first benefits accrue 5 years later).

The potential cost benefit to the user community in inflated dollars is shown in Figure 14.

VI EFFECT OF PARAMETER VARIATION

Since the cost model computes the cost benefits as a population multiplied by the Cost Avoidance Factor (CAF), a change in either can dramatically affect the results. A larger population leads to greater cost benefits and vice versa. The CAF is the unit cost avoidance multiplied by an average spacecraft mass and the average mission life. If the 2500 kg and 5 years estimated were actually 5000 and 10 respectively, the cost benefit would quadruple.

GLOSSARY OF TERMS

CAF	COST AVOIDANCE FACTOR
EVA	EXTRAVEHICULAR ACTIVITY
GFO	GEOSYNCHRONOUS ORBIT
LEO	LOW EARTH ORBIT
LMSC	LOCKHEED MISSILES & SPACE COMPANY, INC.
MTBF	MEAN TIME BEFORE FAILURE
S&R	SERVICE & REFURBISH
STS	SPACE TRANSPORTATION SYSTEM

ORIGINAL PAGE IS
OF POOR QUALITY.

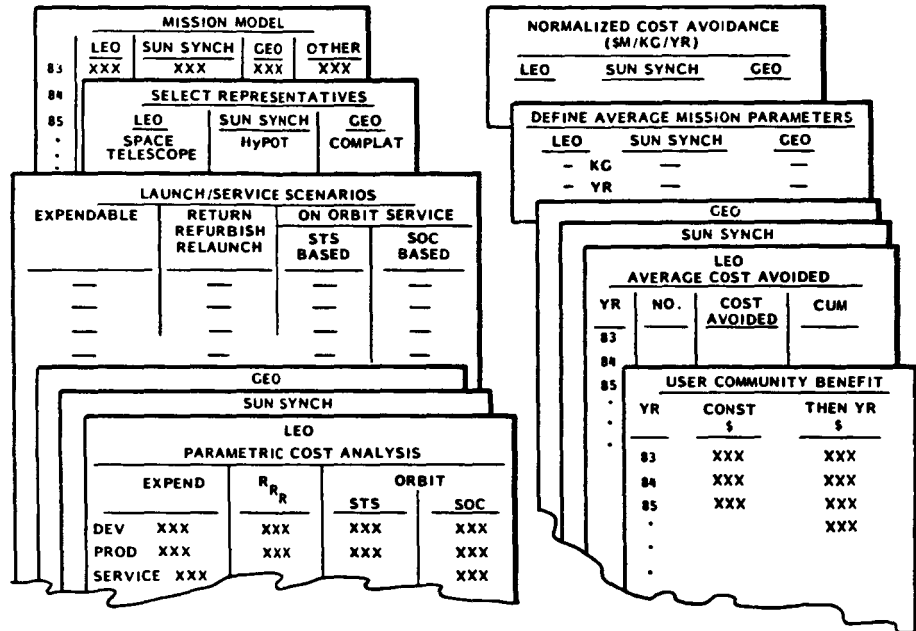

Fig. 1 Satellite Service Cost Benefit Methodology

- USER - NASA
 - QUANTITY - 1
 - ON-ORBIT MASS 10,554 kg (23,268 LB)
 - PLANNED REVISIT CYCLE - 5 YEARS*
 - PLANNED RETURN TO EARTH/REFURBISH CYCLE - 15 YEARS*
 - ORBIT
 - 28.5° INCLINATION
 - 593 km (320 nmi) CIRCULAR ALTITUDE
- *SELECTED FOR COST COMPARATIVE PURPOSES
- USER - U.S. GOVERNMENT
 - CONSTELLATION
 - 9 TOTAL (3 EACH IN 3 PLANES)
 - 98.5 DEGREE INCLINATION
 - ORBIT ALTITUDE 833 km (450 nmi) CIRCULAR
 - MASS ON-ORBIT 3400 kg (7500LB)
 - MISSION DURATION - 15 YEARS
 - PLANNED REVISIT CYCLE - 5 YEARS
 - OPERATIONAL ORBIT ATTAINMENT FROM LEO
 - SELF CONTAINED TWO-WAY CAPABILITY

Fig. 2 Space Telescope Reference Definition

Fig. 3 HyPOT Mission Definition

- USER - COMMERCIAL
- CONSTELLATION
 - 3 (SEPARATE LONGITUDES)
 - 0° INCLINATION
 - SYNCHRONOUS ALTITUDE
- MISSION DURATION: 15 YEARS
- PLANNED REVISIT CYCLE: 5 YEARS
- MASS ON-ORBIT 4,540 kg (10,000 LB)
- SERVICE
 - DEPLOYMENT/CHECKOUT
 - REMOTE REFUELING
 - ORU CHANGEOUT

Fig. 4 Communications Platform Mission Definition

- THE TIME FRAME OF INTEREST TO THIS ANALYSIS IS 1983 - 2000
 - AVERAGE MISSION DURATION FOR THE USER MISSION MODEL IS 5 YEARS
 - AVERAGE SPACECRAFT MASS IS 2500 kg (5500 LB)
 - COST BENEFITS ARE REALIZED ONLY AT THE END OF THE PLANNED LIFE, I.E., 5 YEARS AFTER LAUNCH
- ALL COSTS ARE COMPUTED IN CONSTANT 1982 DOLLARS
- ALL OPERATIONS COST ARE BASED ON PLANNED OPERATIONS (NO EMERGENCY SERVICE)
- OBSOLESCENCE IS NOT EVALUATED
- NASA SUPPORT SYSTEM DEVELOPMENT COSTS ARE SUNK
 - STS - OTV - SOC
- BOTH SATELLITE ON-ORBIT SERVICE AND GROUND REFURBISHMENT RETURN THE SPACECRAFT TO ITS INITIAL OPERATING CONDITION WITH ITS ORIGINAL LIFE EXPECTANCY
- STS IS USED TO LAUNCH BOTH EXPENDABLE AND SERVICEABLE SPACECRAFT
- SERVICEABLE SATELLITE DEVELOPMENT COSTS ARE 20 PERCENT GREATER THAN THOSE FOR EXPENDABLE ON THE AVERAGE
- AVERAGE PRODUCTION COST OF THE SERVICEABLE SATELLITE IS 10 PERCENT GREATER THAN FOR THE EXPENDABLE
- ON THE AVERAGE THE COST OF A SHARED STS FLIGHT, E.G., SATELLITE ON-ORBIT SERVICE OR EARTH RETURN IS 1/2 THE DEDICATED COST
- GROUND REFURBISHMENT OF SATELLITES AND ORUs ARE 1/3 THE UNIT PRODUCTION COST
- COST ESTIMATING RELATIONSHIPS ARE BASED ON THE USAF UNMANNED SPACECRAFT COST MODEL V, SEPT 1981
- ESCALATION INDICES USED ARE FROM THE RCA "PRICE" MODEL (NASA CONTROLLER INDICES END AT 1988)

Fig. 5 Ground Rules and Assumptions

ORIGINAL PAGE IS
OF POOR QUALITY

	<u>SOURCE OF COST ESTIMATE</u>
● HARDWARE	
- SATELLITE	RCA "PRICE H"
- ORBIT REPLACEABLE UNITS (ORU)	RCA "PRICE H"
- SERVICE KITS (ASE)	RCA "PRICE H"
- AGE	RCA "PRICE H"
- FACILITIES	RICHARDSON COST MODEL
● SUPPORT	
- GROUND REFURBISHMENT - SATS, ORU, ASE	"PRICE H"
- TRANSPORT - SATS, ORU, ASE, SPECIALIST	COST REIMBURSEMENT GUIDE
- GROUND OPERATIONS	COST REIMBURSEMENT GUIDE
● LOAD/UNLOAD	COST REIMBURSEMENT GUIDE
● SIMULATION AND TRAINING	LMSC
● POCC	COST REIMBURSEMENT GUIDE
● SATELLITE DOWN TIME	'PRICE L'
- SPACE OPERATIONS	
● EVA	COST REIMBURSEMENT GUIDE
● MMU	COST REIMBURSEMENT GUIDE
● SUPPORT VEHICLES	LMSC
● SOC	"PRICE H" + "PRICE L" (JSC)
● STAY TIME	COST REIMBURSEMENT GUIDE

Fig. 6 Elements of Cost and Sources

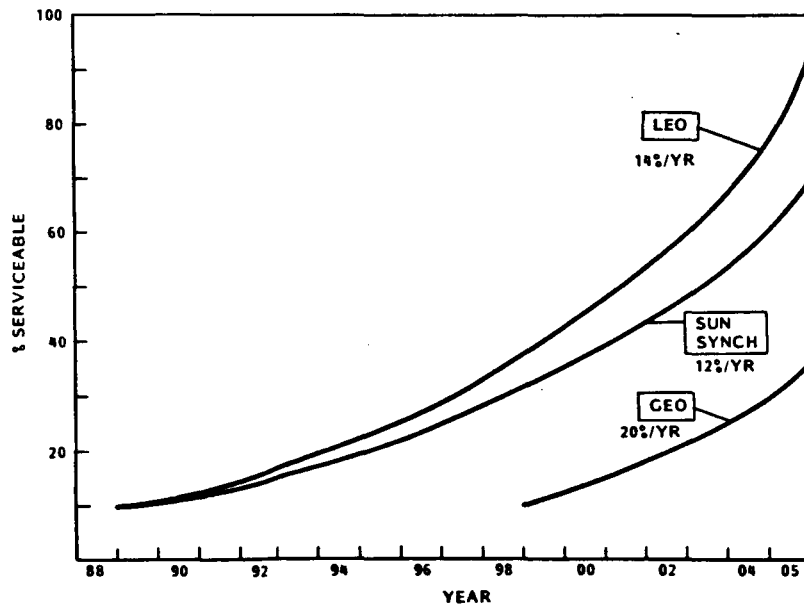

Fig. 7 Serviceability Growth Model

CASE I - EXPENDABLE

- LAUNCH ST WITH STS
- ST EXPENDED IN 5 YEARS
- REPLACE ST AT 5 YEARS
- REPLACE ST AT 10 YEARS

CASE II - EARTH RETURN, REFURBISH, RELAUNCH

- LAUNCH ST WITH STS
- RETURN ST TO EARTH WITH STS AT 5 YEARS
- RELAUNCH REFURBISHED ST WITH STS
- RETURN ST TO EARTH WITH STS AT 10 YEARS
- RELAUNCH REFURBISHED ST WITH STS
- ST EXPENDED AT 15 YEARS

CASE III - ON-ORBIT SERVICE + RETURN

- LAUNCH ST WITH SPACE TRANS SYSTEM (STS)
- SERVICE ST IN ORBIT WITH STS AT 5 YEARS
- SERVICE ST IN ORBIT WITH STS AT 10 YEARS
- RETURN ST TO EARTH AT 15 YEARS

CASE IIIA - ON-ORBIT SERVICE

- LAUNCH ST WITH STS
- SERVICE ST WITH STS AT 5 YEARS
- SERVICE ST WITH STS AT 10 YEARS
- ST EXPENDED AT 15 YEARS

Fig. 8 LEO Scenarios

CASE I - EXPENDABLE

- LAUNCH THREE HyPOTs FOR EACH OF THREE STS FLIGHTS
- HyPOTs HAVE FIVE YEAR LIFE
- LAUNCH NINE MORE HyPOTs AT 5 YEARS
- LAUNCH NINE MORE HyPOTs AT 10 YEARS
- HyPOTs EXPENDED AFTER 5 YEARS

CASE II - EARTH RETURN, REFURBISH, RELAUNCH

- LAUNCH THREE HyPOTs ON EACH OF THREE STS FLIGHTS
- REPLACE NINE HyPOTs AT 5 YEARS USING THREE STS FLIGHTS
 - 1ST REPLACES 3 WITH 3 NEW
 - 2ND REPLACES 3 WITH 3 REFURBISHED FROM FLIGHT NO. 1
 - 3RD REPLACES 3 WITH 3 REFURBISHED FROM FLIGHT NO. 2
- REPEAT REPLACEMENT AT 10 YEARS
- HyPOTs EXPENDED AT 15 YEARS

CASE III

- LAUNCH THREE HyPOTs WITH EACH OF THREE STS FLIGHTS
- SERVICE EACH HyPOT FROM STS AT 5 YEARS
- SERVICE EACH HyPOT FROM STS AT 10 YEARS
- HyPOTs EXPENDED AFTER 15 YEARS

Fig. 9 Sun Synch Scenarios

CASE I - EXPENDABLE

- LAUNCH COMPLAT WITH OTV USING STS
- LAUNCH THREE MORE AT 5 YEARS
- LAUNCH THREE MORE AT 10 YEARS
- OTV EXPENDED AT 10 YEARS
- COMPLAT EXPENDED AT 15 YEARS

CASE III - STS BASED ON-ORBIT SERVICE

- LAUNCH COMPLAT AND OTV USING STS
- OTV PLACES COMPLAT INTO SYNC EQ ORBIT
- OTV RETURNS TO STS
- STS RETURNS OTV TO EARTH
- OTV IS REFURBISHED
- OTV IS REUSED TO LAUNCH COMPLATS NO. 2 AND 3
- SINGLE OTV SERVICES THREE COMPLATS AT 5 AND 10 YEARS
- OTV RETURNS TO STS
- STS RETURNS OTV TO EARTH FOR REFURBISH, REUSE
- COMPLATS EXPENDED AT 15 YEARS

CASE IV - SOC BASED ON-ORBIT SERVICE

- LAUNCH THREE COMPLATS WITH STS
- SOC HAS OTV AVAILABLE
- OTVs PLACE THREE COMPLATS INTO SYNC EQ ORBIT
- OTV RETURNS TO SOC AFTER EACH USE
- OTV REFURBISHED AT SOC
- SINGLE OTV SERVICES THREE COMPLATS AT 5 AND 10 YEARS
- COMPLAT EXPENDED AT 15 YEARS

Fig. 10 GEO Scenarios

ORIGINAL PAGE IS
OF POOR QUALITY

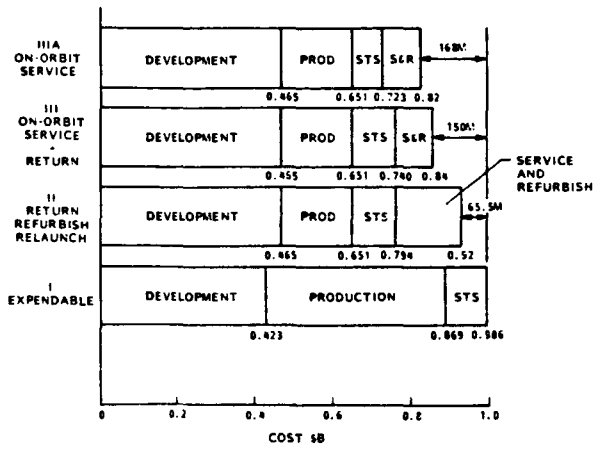

Fig. 11A LEO Cost Estimate

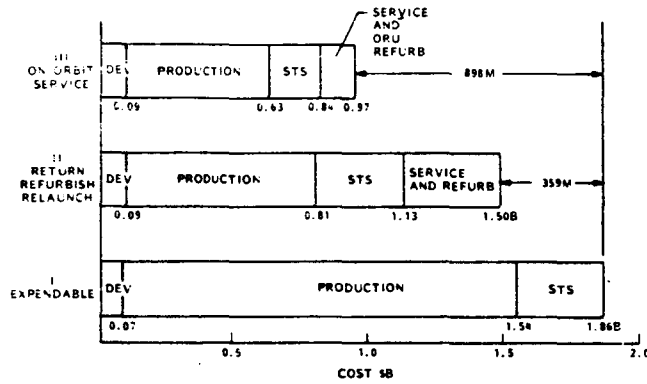

Fig. 11B Sun Synch Options Cost Estimate

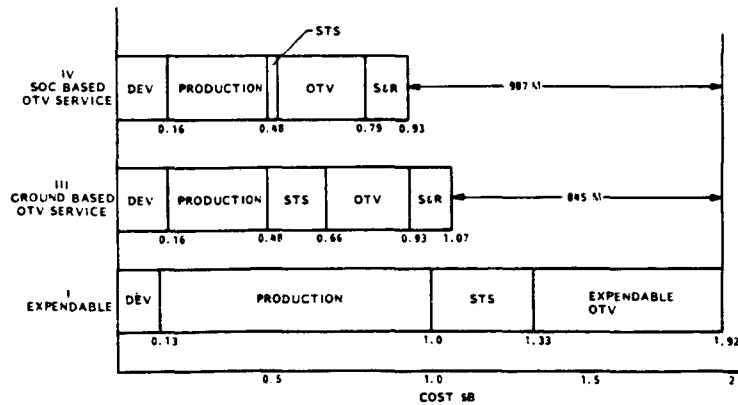

Fig. 11C GEO Cost Estimate

COST AVOIDANCE FACTOR (CAF) IS:
THE COST AVOIDED RELATIVE TO THE EXPENDABLE SPACECRAFT
PER TONNE SPACECRAFT MASS
PER YEAR OF SPACECRAFT OPERATION

BASIS	RETURN, REFURBISH RELAUNCH	ON-ORBIT SERVICE	
		STS BASED	SOC BASED
LEO			
GROSS (\$M)	65.5	168	-
CAF (\$M.t/YR)	0.42	1.06	-
SYN SYNCH			
GROSS (\$M)	359	898	-
CAF (\$M.t.HR)	0.77	1.96	-
GEO			
GROSS (\$M)	-	845	987
CAF (\$M.t.YR)	-	4.14	4.83

Fig. 12 Cost Avoidance Factors

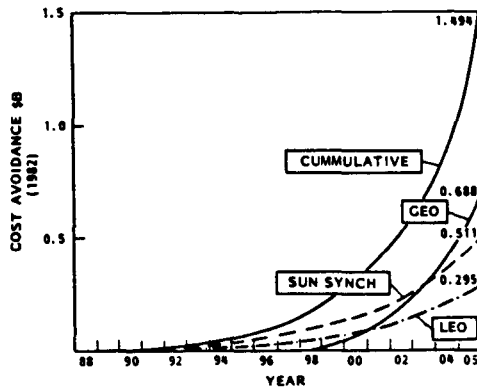

Fig. 13 Potential Cost Avoided by the User Community

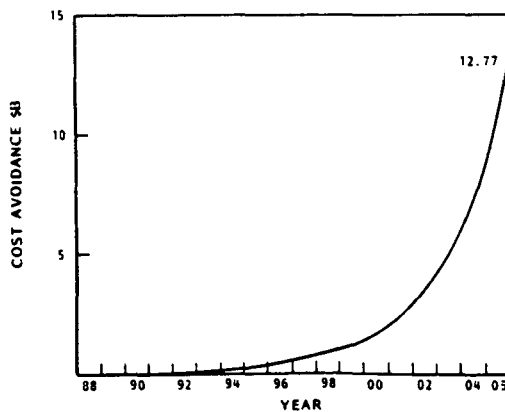

Fig. 14 Potential Cost Avoidance in Then Year Dollars

1088 11188

SATELLITE SERVICES WORKSHOP
NASA/JSC, 22 - 24 JUNE 1982
SATELLITE DESIGN SESSION

DESIGN OF THE MATERIALS EXPERIMENT CARRIER
FOR ON-ORBIT SERVICING

BY

DONALD M. WALTZ AND HANS F. MEISSINGER
TRW
REDONDO BEACH, CALIFORNIA

Contents

	<u>Page</u>
1. Introduction	1
2. Role of MEC	2
3. On-Orbit Servicing Definition	3
4. MEC System Requirements	3
5. MEC Configurations	6
6. MEC Design for On-Orbit Servicing	7
7. On-Orbit Servicing	14
8. Mission Characteristics	19
9. Servicing Modes	25
10. Servicing Cost Model	25
11. Conclusions	27

DESIGN OF THE
MATERIALS EXPERIMENT CARRIER
FOR
ON-ORBIT SERVICING

Waltz
Field Operations Division
and Technology Group
each, California

Hans F. Meissinger
Mission and Systems Engineering
TRW Space and Technology Group
Redondo Beach, California

1. INTRODUCTION

Materials Experiment Carrier (MEC) is needed to advance materials engineering in space toward a fuller, more effective and economical utilization space environment, starting with a broadened research flight program Shuttle/Spacelab and thrusting to full scale commercial applications on the Platform.

A major facet of the orderly transition from crew tended Shuttle/Spacelab to fully automated operations on MEC/Space Platform missions can be aided by planned, periodic on-orbit servicing events that are part of the mission scenario. This will create the opportunity for timely replacement of materials processing payload units or payload samples. Design of MEC for on-orbit servicing is feasible; the economics of on-orbit servicing looks promising.

On-orbit servicing, like other MEC mission phases requiring repeated Shuttle/Space Platform rendezvous and docking, will involve intricate, crew supported, delicate operations that will gradually evolve into routine activities. This aspect of the MEC mission does not require novel technology, per se, but does involve a build up of experience by Shuttle flight crews. Principal concerns regarding MEC design and mission planning for on-orbit servicing are: (1) an awareness of the inherent complexity of the orbital operations, (2) a practical design approach that emphasizes simplicity and reliability, and (3) implementation of interface design solutions that eliminates safety risks involved in payload manipulation by Shuttle crewmen.

This paper discusses the MEC system and its mission from the viewpoint of on-orbit servicing. Information is provided on MEC system requirements, design features for on-orbit servicing, on-orbit servicing operations and rationale and relative servicing costs.

All of the information presented herein is taken from a study TRW performed for the NASA/Marshall Space Flight Center. This study Materials Experiment Carrier Concepts Definition Study was performed from October 1979 through December 1981. (Contract No. NAS8-33688). Mr. Kenneth R. Taylor of Program Development at MSFC was the NASA COR for this study.

2. ROLE OF MEC

The U.S. National Aeronautics and Space Administration is currently sponsoring a Materials Processing in Space (MPS) program that involves both ground and space-based research and will require frequent and cost-effective access to the space environment to accomplish its goals. Initially research-oriented, the program will be aimed eventually at space utilization for commercial ventures.

Several first-generation research and commercial payloads are under design and development. They will be carried by the space Shuttle/Spacelab on earth orbital flights starting in the mid 1980's. These missions will focus on acquisition of materials behavior research data, the potential enhancement of earth-based technology, and initial processing experimentation for specialized high-value materials.

The early short-duration and power-limited Shuttle/Spacelab missions will accomplish important MPS research and development. Projected MPS needs in terms of numbers of samples, processing time, and power required to support sustained, systematic space processing activities however, will soon exceed Shuttle capabilities.

The Materials Experiment Carrier (MEC) will provide these augmented capabilities to materials processing in space in the post 1986 era. The MEC vehicle, carrying multiple, advanced MPS payloads will fly attached to the Space Platform. It will be launched and later retrieved by the Shuttle Orbiter, and it will be reflown repeatedly after refurbishment on the ground. Revisits of MEC by the Shuttle for servicing on orbit are also envisioned to enhance mission effectiveness and reduce operational costs.

Compared with MPS/Slacelab, MEC offers:

- Greatly extended mission durations (90 days and longer) for processing a significant number of material samples at affordable costs
- Greater processing power (10 kW and higher)
- A sustained undisturbed micro-gravity environment (with a goal of $10^{-6}g$ and better)
- An evolutionary step to the goal of commercial space processing

3. ON-ORBIT SERVICING DEFINITION

In the MEC study, on-orbit servicing was defined as the:

- (1) Replacement of a materials processing payload or
- (2) Changeout of only the sample magazine or storage compartment within payloads or
- (3) Replacement of a malfunctioning major subsystem or component or
- (4) Some combination of the above

That is, on-orbit servicing operations pertain to exchange of entire payloads, processed samples, or subsystems. Servicing, in this study, did not consider orbital troubleshooting, repair, routine maintenance or calibration of instrumentation or processing equipment.

4. MEC SYSTEM REQUIREMENTS

MEC is a payload of the Space Platform. It always flies attached to the platform. MEC system requirements are given in Figure 1. The principal requirements are keyed to:

1. The projected growth of the Space Platform (SP) from an initial moderately sized vehicle providing up to 12.5 kW power to payloads into a later, full capacity version which will delivery nominally up to 25 kW.
2. An anticipated SP initial operational capability (IOC) in 1987 or 1988.
3. The projected schedule of two Space Platform revisits per year by the Shuttle Orbiter for purposes of SP payload changeout.

DESIGN

1. MEC WILL EVOLVE FROM INITIAL CAPABILITY (9 TO 11 KW NOMINAL, 18 KW PEAK) TO FULL ("ALL-UP") CAPABILITY (25 KW NOMINAL, 40 KW PEAK) PACED BY SP GROWTH AND MPS PAYLOADS EVOLUTION
2. PAYLOADS FOR INITIAL MEC MISSIONS WILL INCLUDE
 - ADVANCED SOLIDIFICATION EXPERIMENT SYSTEM (SES) 3-5 KW
 - UP TO 7 PAYLOAD FACILITIES, ADAPTED FROM ADVANCED MEA⁽¹⁾ 3-5 KW EACH
 - ELECTROPHORESIS OPERATIONS IN SPACE (EOS) 3-5 KW
3. LIMITED SP POWER CAPACITY AND ACCOMMODATION OF OTHER USERS REQUIRES TIME-SHARED MEC PAYLOAD OPERATION
4. PAYLOADS WILL OPERATE AUTONOMOUSLY, MONITORED AND CONTROLLED BY MEC CENTRAL CDMS
5. ACCESS TO PAYLOADS FOR ON-ORBIT SERVICING (P/L OR SAMPLE CHANGEOUT) WILL BE REQUIRED ONLY ON ALL-UP MEC
6. MEC DESIGN AND OPERATION CONSTRAINED BY STS AND ASTRONAUT SAFETY REQUIREMENTS

MISSION

1. MEC/SP MISSIONS CHARACTERIZED BY
 - LONG STAY TIME IN ORBIT (180 DAYS AND LONGER)
 - HIGH POWER LEVEL TO PAYLOADS (UP TO 25 KW NOMINAL)
 - SUSTAINED, UNDISTURBED MICRO-ENVIRONMENT ($\leq 10^{-5}g$)(2)
2. SIX MONTH BASELINE MISSION DURATION CONFORMS WITH PROJECTED TWICE-A-YEAR SP REVISITS BY SHUTTLE
3. MEC IS UNCONSTRAINED AS TO ORBIT ALTITUDE AND INCLINATION, ORIENTATION AND BERTHING PORT ASSIGNMENT
4. ONLY CRITICAL MEC PROCESSES AND PROCESS PHASES REQUIRE INTERACTIVE CONTROL BY POCC, IN NEAR-REAL-TIME, VIA TDRSS/SP FORWARD AND RETURN RELAY LINKS.
5. TELEOPERATOR MANEUVERING SYSTEM (TMS) MAY BE USED IN MEC DEPLOYMENT, RETRIEVAL AND SERVICING TO REDUCE ORBITER MANEUVER REQUIREMENTS
6. MEC IS A REUSABLE, VERSATILE CARRIER OF MPS PAYLOADS

(1) MEA-MATERIALS EXPERIMENT ASSEMBLY, WILL FLY ORIGINALLY ON SPACE SHUTTLE AS AN ORBITER BAY PAYLOAD

(2) OCCASSIONAL MICRO- g DISTURBANCES OF ABOUT $10^{-3}g$ ACCEPTABLE TO SOME PAYLOADS

Figure 1. MEC System Requirements

4. A set of: (1) early MEC materials processing payloads, to include up to seven advanced MEA type facilities, a solidification experiment system (SES), and a commercial processing facility, known as Electrophoresis Operations in Space (EOS), and (b) full capability MEC payloads to include the above early payloads plus some mixture of the following candidate MPS facilities:

(1) Advanced Solidification Experiment System

- A. Isothermal
- B. Directional Solidification

(2) High Gradient Directional Solidification

(3) Float Zone

(4) Acoustic Containerless

(5) Electromagnetic Containerless

(6) Electrostatic Containerless

(7) Solution Crystal Growth

(8) Vapor Crystal Growth

(9) Bioprocessing

(10) Commercial Payloads

Accordingly, the MEC concept addressed the following:

- (a) The MEC design will evolve from an initial, limited capacity version, designed for use with the initial 12/5 kW SP into a full capacity "all-up" configuration that can fully utilize the resources of the later, full capacity (25 kW) Space Platform.
- (b) The estimated time frame for missions of the initial MEC is in the late 1980's, those of the all-up MEC is 1990 and beyond.
- (c) MEC mission durations, even initially, will be 180 days, as dictated by the projected SP revisits by the Shuttle. Missions of the all-up MEC may be extended to last for several revisit cycles i.e., 12 months or 18 months if necessary to meet program objectives, depending on MPS payloads and their orbital stay time requirements.
- (d) MEC on-orbit servicing for payload or sample exchange is not contemplated for the initial, 180-day missions as there will be no Shuttle revisits at shorter time intervals. However, servicing may be required in support of all-up MEC operations if missions extend to 12 months or longer durations.

- (e) In the projected MEC evolution from an initial to an all-up mission, design commonality and possible use of applicable existing hardware should be emphasized.

Thus, the Advanced Materials Experiment Assembly, MEA-C, currently being designed by NASA/MSFC for Shuttle-based missions preceding MEC or the standard Spacelab Pallet, are leading candidates for providing the support structure or support subsystems to be used in the initial MEC design concept. They might possibly also be used as building blocks in the evolution of the all-up MEC.

Payloads carried in all-up MEC missions shall have design and performance characteristics that are consistent with, and facilitate on-orbit servicing operations. Servicing operations will include exchange either of entire payload or only of sample magazines within payloads, and possibly the replacement of malfunctioning payload subsystems.

Servicing operations will require payload and component handling by the Shuttle Remote Manipulator System (RMS) or manually, by a crew. In addition, convenient and safe access to internal equipment shall be provided via access hatches of sufficiently large size.

5. MEC CONFIGURATIONS

The role of the SP in the evolving MPS program is shown in Figure 1. The Shuttle can accommodate low power, short duration MPS R&D, large specimen size, sample size, and higher melting points pose the need for as well as MPS carrier systems that are compatible with both the Shuttle and flight modes.

Currently, the MPS program is developing automated payloads for Shuttle cargo bay and manned payloads to fly both in the Shuttle and in the Spacelab module. This automated work is expected to lead to the development of a customized MPS payload carrier for automated MPS payloads. Materials Experiment Carrier. Concepts for this carrier have been developed that will minimize Shuttle user charges, which is most important to Shuttle users. Figure 2 depicts the selected MEC concept which can begin as a carrier and grow in modular steps to accommodate MPS payloads or can be used as a carrier and grow in modular steps to accommodate MPS payloads or has seven compartments so that several different processes can be carried out in parallel, or several different products produced in parallel. This would optimize the facility utility and the time on orbit.

ORIGINAL PAGE IS
OF POOR QUALITY

- Minimize cost on commercial Shuttle sorties

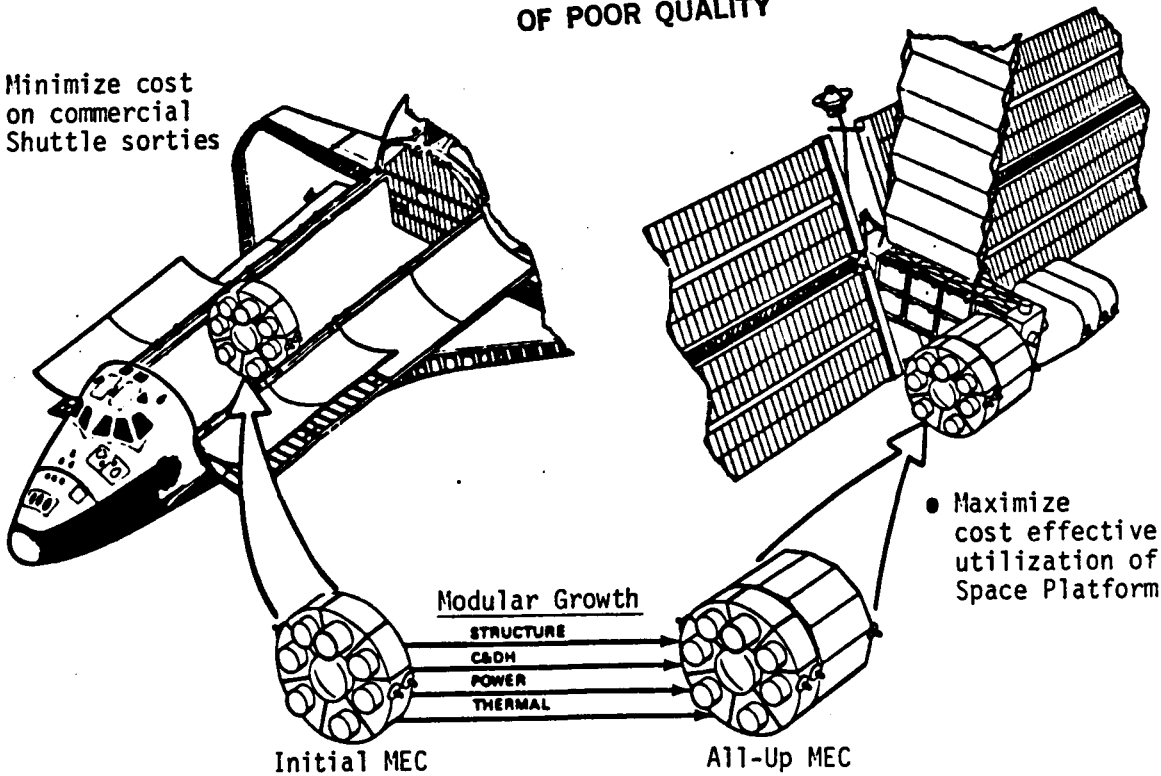

Figure 2. MEC Growth and Utility*

6. MEC DESIGN FOR ON-ORBIT SERVICING

The selected initial MEC concept is based on adaptation of the Advanced MEA spoked disc support structure and subsystem design. The payloads are attached axially through access doors or openings in one bulkhead. This permits larger payload units to be accommodated than by radial insertion.

An alternative design is based on adaptation of the standard Spacelab pallet.

Growth to the all-up MEC configuration is achieved through addition of a four-compartment, side-loaded, drum-shaped add-on module that is attached to the disc-shaped MEC core module. Subsystems located in the core module are retained with extension of capability, as required to support the added payloads.

*Figure 2 is from a paper titled A Focus for Space Industrialization by W.R. Marshall, W.T. Carey, and K.R. Taylor of NASA/MSFC. It was presented at the 19th Space Congress, Cocoa Beach, Florida, 29 April 1982

In the case of the pallet based MEC design, growth to the all-up version could be achieved by addition of a second pallet in tandem with the first.

INITIAL MEC

Figure 3 shows the initial MEC configuration with EOS attached. Figure 4 shows an exploded view of MEC and EOS in the alignment used for berthing to the Space Platform aft payload port (+x port). This illustration also shows two other payload ports (+z and -y ports) to which the MEC/EOS might be attached, assuming that four such ports are available on the Space Platform. Six MEA-C type cylindrical payloads of equal size are shown protruding from the peripheral compartments of the MEC disc structure, while SES occupies the center compartment. One peripheral compartment, i.e., that located adjacent to the EOS berthing adapter, is used to house the MEC subsystems.

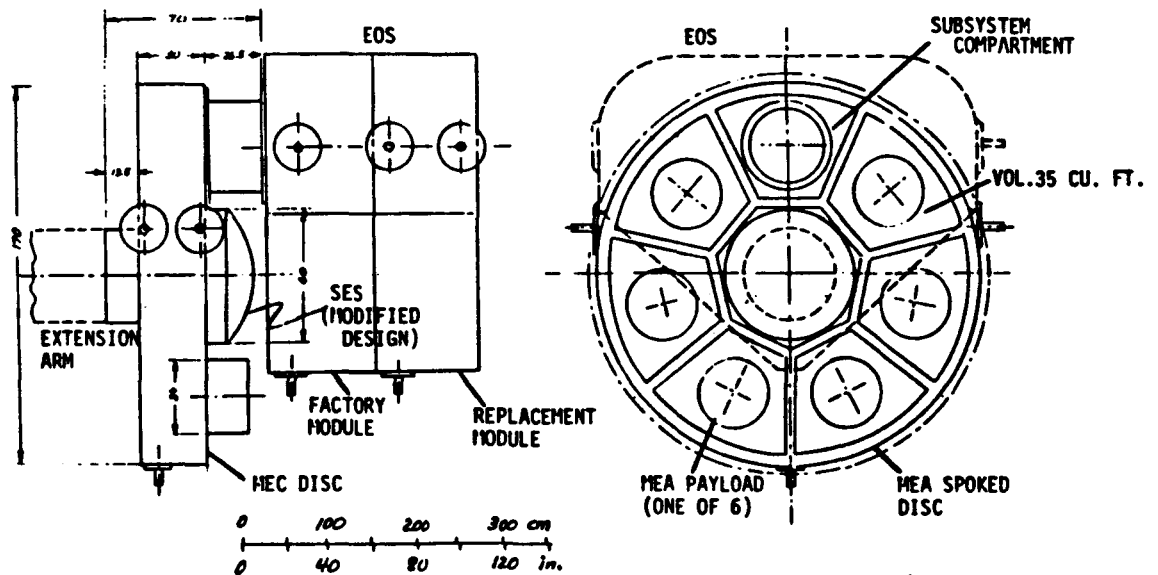

Figure 3. Initial MEC Configuration, Including EOS

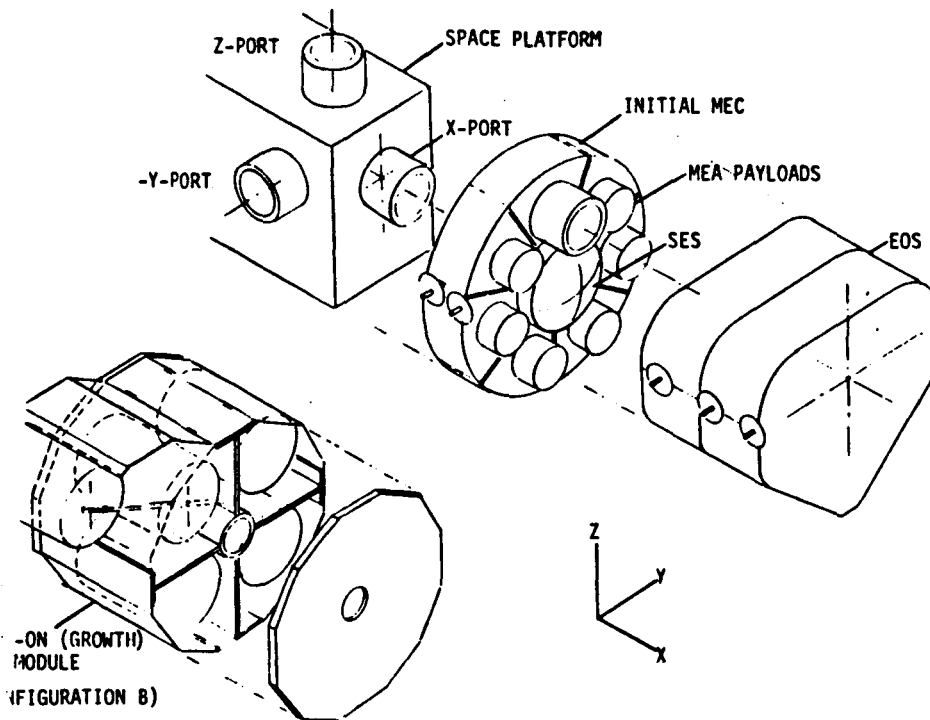

Figure 4. Initial MEC (Spoked Disc) Configuration and Add-On Growth Module

EVOLUTION OF INITIAL TO ALL-UP MEC

Evolution to all-up MEC will require primarily an increase in payload accommodation capacity. The preferred approach is to add a growth module to initial MEC which, by preserving its basic subsystems and payload accommodation capability, then becomes the "core" module of the all-up MEC.

Secondly, the development of payloads servicing capability from the initial MEC (which does not have to provide this capability) will be required. The impact of this requirement on the design and arrangement of the core and growth modules can be summarized as follows:

1. By utilizing the initial MEC as core module a part of the payloads accommodated in the all-up MEC will be of limited size, comparable to MEA facilities. Such payloads will probably be of exploratory design, requiring only short mission durations.

2. MEC missions durations will initially be 6 months, but will ultimately evolve to 12 months or more. At least the exploratory type of payloads may have to be exchanged at 6-month intervals. Consequently, the core module will require conversion to serviceability.
3. Core module conversion will be feasible if the initial design makes appropriate provisions for payload attachment/removal on orbit.
4. Axial payload attachment was previously shown to be advantageous on the initial MEC. With this design feature retained in the core module, it will be necessary to arrange the core module at the aft end of the all-up MEC. The growth module, placed between the SP berthing port and the core module, will therefore require side access to its payload compartments.
5. With this arrangement and the MEC subsystems still housed in the core module, it will be necessary to carry power and signal cables and coolant lines through the growth module into the core module resulting in a small weight penalty.

ALL-UP MEC CONFIGURATION

Retention of the initial MEC as core module for the all-up MEC reflects in subsystem placement and in access provisions for the core module payloads for on-orbit servicing. On-orbit serviceability of payloads in the all-up MEC permits long mission durations for some of the payloads, e.g., those carried by the add-on module, without requiring the same orbital stay time for others.

As shown in the configuration drawing, Figure 5, the four-payload growth module is attached at the forward bulkhead of the six-payload core module. As in the initial MEC configuration, EOS is again attached to an off-center berthing adapter placed adjacent to the trapezoidal compartment of the core model that houses the MEC subsystems. With the growth of subsystem capacity and size required to support the all-up MEC system, a second trapezoidal compartment will be dedicated to housing subsystems and other support equipment, e.g., a waste retention tank. Hence, the reduction of core module payload capacity by one unit.

A utility tunnel, shown in the center of growth module cross section, on the right, is used to connect power and signal conduits and coolant lines from the SP berthing adapter to the MEC subsystem compartments, and vice versa.

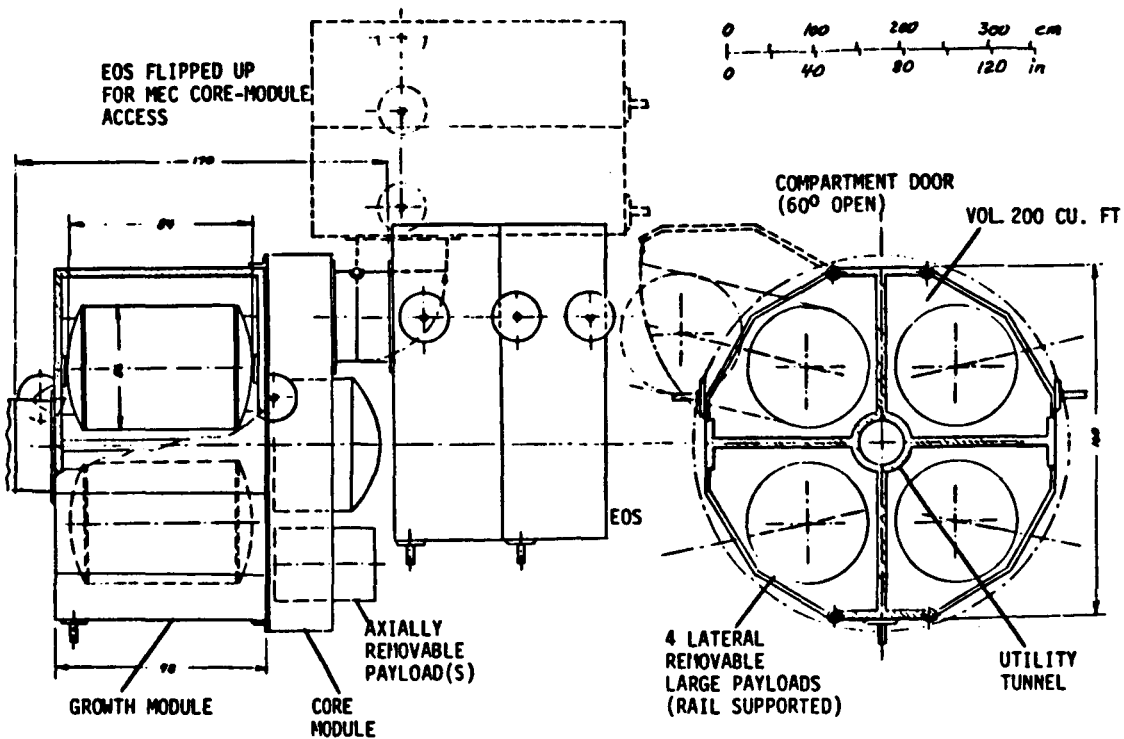

Figure 5. All-Up MEC Configuration, Including EOS

Some extra length of power cable (7 ft), signal cables and fluidlines (14 ft) is unavoidable with the selected design approach, which caters to the servicing access objective for payloads carried by the core module

Another design feature keyed to this objective is the provision for moving the EOS assembly out of the way to allow access to core module payloads. As shown in the MEC side view drawing, this is accomplished by a hinge in the EOS berthing adapter. Design details of this feature still require further definition. The preliminary concept shown here assumes that the retention mechanism in the active half of the adapter carried by MEC will be released prior to flip-up, with flexible cables and fluid lines having enough slack to permit the desired hinge rotation. This would avoid having to disengage the electrical and fluid connectors at the MEC/EOS interface. Several alternative designs have been investigated that similarly do not require modification of the passive adapter half carried by EOS, i.e., the extra cost of

interface modification needed to provide core module servicing access would be absorbed by the MEC design rather than by EOS. A simpler, though operationally less attractive, option would involve EOS removal to a temporary parking location by the Shuttle remote manipulator whenever MEC core module access is required.

Note that the EOS swing-out concept illustrated here is made feasible by the off-center location of the berthing adapter.

Figure 6 shows an isometric view of the all-up MEC with a full payload complement. The drum-shaped, twelve-sided growth module is shown with one of the four payload compartment doors opened. Lateral access to the payloads is illustrated, with one payload canister extended on guide rails for servicing or removal. Payload changeout will require handling by the RMS with EVA crew assistance. RMS grapple fixtures required for MEC deployment or stowage and for payload changeout will be inserted manually by the crewman into receptacles provided for this purpose.

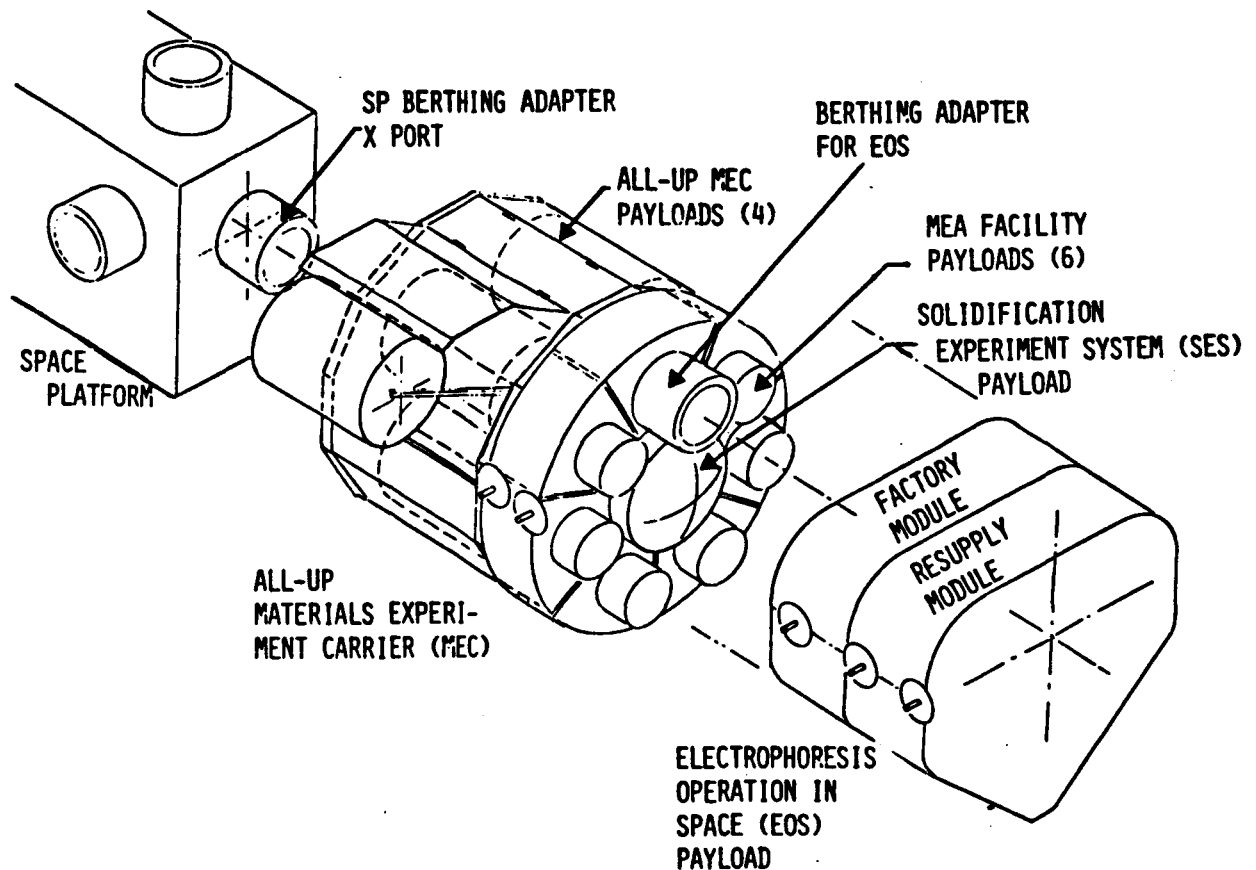

Figure 6. All-Up MEC Configuration With Payloads

SELECTED MEC CONCEPT SUMMARY

Principal features, dimensions and weight estimates of the selected design concepts for the initial and all-up MEC are summarized in Figure 7. The spread of estimated weights ranges from 8000 to 10,100 lb for the initial MEC and from 14,970 to 26,310 for the all-up MEC, including 20% for weight contingencies. The large weight variation in the latter case is due to the 1,000 to 3,000 lb weight range for each of the four major payload units carried in the growth module, based on results of the payload survey conducted in the MEC study.

ITEM	INITIAL MEC	ALL-UP MEC
HOST VEHICLE	INITIAL SPACE PLATFORM (12.5 KW)	GROWTH SPACE PLATFORM (25 KW)
CONFIGURATION	MEA SPOKED DISC, MODIFIED 14 FT DIAMETER, 30 IN. NET LENGTH (70 IN. GROSS LENGTH, INCL. ADAPTERS) ⁽¹⁾	INITIAL MEC (CORE MODULE) IN TANDEM WITH GROWTH MODULE (MEC B) 14 FT DIAMETER 130 IN. NET LENGTH (170 IN. GROSS LENGTH, INCL. ADAPTERS) (1)
PAYLOADS	SES, 6 ADVANCED MEA FACILI- TIES, EOS (ATTACHED IN TANDEM)	SES, 5 TO 6 SMALL PAYLOADS (IN CORE MODULE), 4 LARGE PAYLOADS (GROWTH MODULE), EOS (ATTACHED IN TANDEM)
SUBSYSTEMS	POWER DISTRIBUTION AND CONTROL, THERMAL CONTROL, ⁽²⁾ CDMS, CONTAMINANT CONTROL/RELEASE, STRUCTURE AND MECHANISMS	
EST. WEIGHT (LB)		
STRUCTURE	1330 ⁽³⁾	2850 ⁽³⁾
SUBSYSTEMS	800	960
PAYLOADS ⁽⁴⁾	4,480 MIN 6,290 MAX	8,840 MIN 18,300 MAX
CONTINGENCY (20%)	<u>1,390</u> <u>1,680</u>	<u>2,320</u> <u>4,200</u>
TOTAL	8,000 MIN 10,100 MAX	14,970 MIN 26,310 MAX

- (1) ADD 40 IN. FOR SP AND EOS ADAPTERS (DOES NOT INCLUDE 44-IN. EXTENSION ARM)
- (2) ALL-UP MEC MAY INCLUDE AUXILIARY RADIATOR
- (3) INCL. 160 LB FOR 2 ADAPTERS
- (4) NOT INCLUDING 10,000 LB FOR EOS

Figure 7. Selected MEC Concept Summary

7. ON-ORBIT SERVICING

On-orbit servicing will be required in all-up MEC missions to increase mission cost effectiveness, by

- Extending mission duration and thus increasing mission output, i.e., the number of samples processed per mission,
- Reducing the number of MEC launches and retrievals required per year, thereby greatly reducing transportation costs,
- Achieving improved payload/mission matching, and more effective Space Platform utilization by MEC, e.g., through replacement of payload units that complete their mission objectives ahead of others

Servicing is not projected on initial MEC missions (a) to simplify the design and thus save initial MEC development cost, and (b) because Shuttle revisits to the Space Platform are projected to occur only twice per year. An orbital stay time of 180 days, conforming with this schedule, is considered sufficiently long for any initial MEC mission so that on-orbit servicing would not even be useful. Most of the considerations discussed in this section therefore will apply to the all-up MEC only.

MEC payloads will have design interface characteristics that are consistent with, and facilitate on-orbit servicing. Servicing operations will include exchange either of entire payload units or only of sample magazines within payloads. Figure 8 compares objectives and design implications of payload changeout vs. sample changeout.

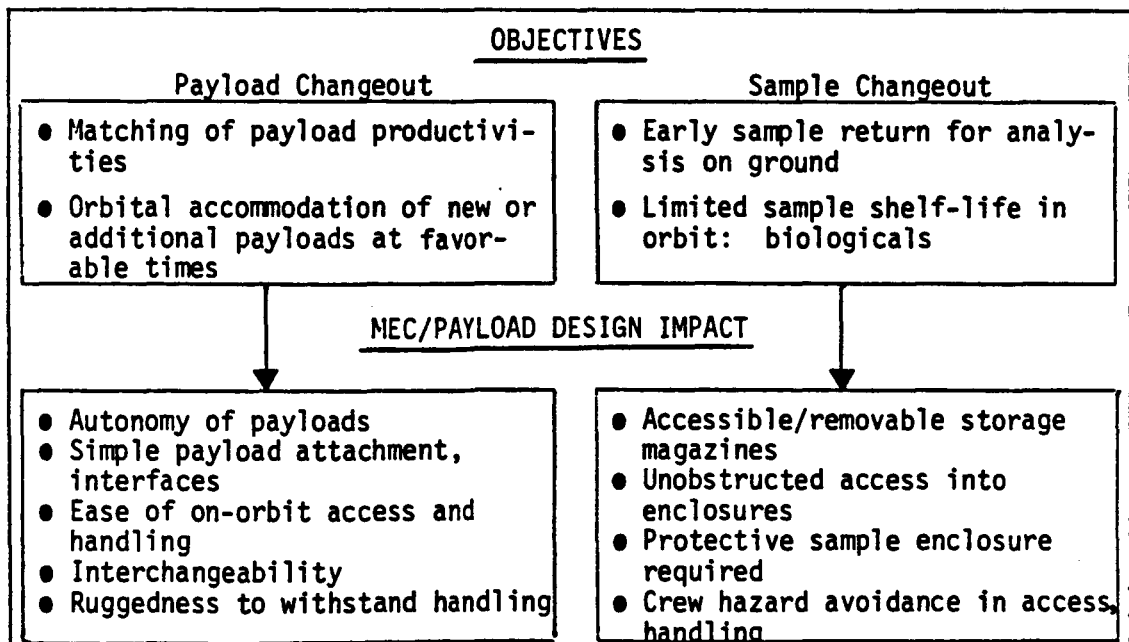

Figure 8. Objectives and Design Implications of Payload and Sample Changeout On-Orbit

MISSION SCENARIOS WITH AND WITHOUT SERVICING

Four principal scenarios are illustrated in Figure 9. The first, third and fourth of these do not permit or require on-orbit servicing, the second envisions servicing to aid in extending on-orbit operation beyond the projected six-month interval between successive Orbiter visits of the Space Platform. A different mission concept without on-orbit servicing, illustrated in scenario four, foresees alternate launches of two MEC vehicles. One vehicle is refurbished on the ground while the other is in orbit.

1. INITIAL MEC

- NO SERVICING
- RETRIEVE AFTER 6 MONTHS

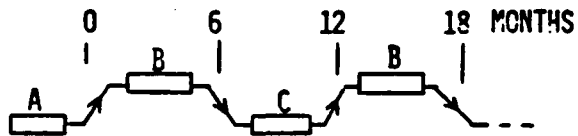

2. ALL-UP MEC (1 UNIT)

- SERVICE AFTER 6 MONTHS

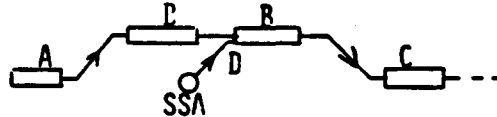

3. ALL-UP MEC (1 UNIT)

- NO SERVICING
- RETRIEVE AFTER 6 OR 12 MONTHS

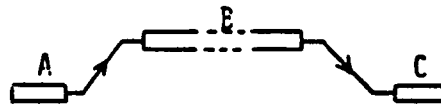

4. INITIAL OR ALL-UP MEC (2 UNITS)
IN INVENTORY

- NO SERVICING
- ALTERNATE LAUNCHES EVERY 6 MONTHS

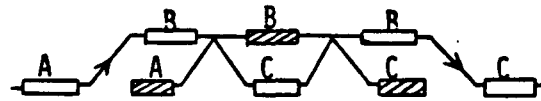

LEGEND:

- A - P/L INTEGRATION
- B - ON-ORBIT OPERATIONS
- C - REFURB. ON GROUND
- D - RENDEZVOUS AND P/L EXCHANGE

NOTE: PROJECTED 6 - MONTH STS LAUNCH INTERVAL IS REFLECTED IN EACH OF THESE SCENARIOS. SCENARIO 1 AND 4 KEYED TO 6 MONTH REFURBISHMENT/TURN AROUND TIME ON GROUND. INCREASE TO 8 MONTHS WOULD REDUCE REFLIGHT FREQUENCY.

Figure 9. Mission Scenarios With and Without Servicing

Results of an analysis performed to determine the comparative advantages of missions with or without servicing capability are listed in Figure 10.

**ORIGINAL PAGE IS
OF POOR QUALITY**

	ADVANTAGES	DISADVANTAGES
(A) NO SERVICE-SINGLE MEC	<ul style="list-style-type: none"> ● SIMPLER DESIGN ● SIMPLER DEPLOYMENT TASK ● NO SERVICE SUPPORT ASSEMBLY ● LESS ASTRONAUT TRAINING 	<ul style="list-style-type: none"> ● LESS MISSION AND PAYLOAD DEPLOYMENT FLEXIBILITY THAN (B) AND (C) ● MISSION DURATION GENERALLY CONSTRAINED TO 6 MONTHS, IMPACTS PRODUCTIVITY
(B) NO SERVICE-TWO MEC'S*	<ul style="list-style-type: none"> ● SAME AS ABOVE, PLUS ● OBTAIN MORE PAYLOAD ORBIT TIME THAN IN (A), I.E., MORE FLIGHT OPPORTUNITIES (CONSISTENT WITH RAPID INCREASE IN NUMBER OF P/L CANDIDATES) 	<ul style="list-style-type: none"> ● NEED ADDITIONAL MEC UNIT ● HIGH NUMBER OF LAUNCHES DRIVES UP COST ● NOT AS COST EFFECTIVE UNLESS LARGE P/L FLIGHT DEMAND BACKLOG
(C) SERVICING-SINGLE MEC	<ul style="list-style-type: none"> ● OBTAIN MORE P/L ORBIT TIME THAN (A) WITHOUT FREQUENT MEC RELAUNCH AS IN (B) ● GREATER FLEXIBILITY <ul style="list-style-type: none"> - P/L MIX - MISSION DURATION - P/L DEPLOYMENT STATUS ● REDUCE COST PER KW-HR 	<ul style="list-style-type: none"> ● COST OF SERVICE SUPPORT ASSEMBLY ● EXTRA COST OF CREW TRAINING, EXTENDED SORTIE DURATION ● EXTRA COST OF SERVICEABILITY ● EXTRA COST OF SSA ● EXTRA COST OF GROUND SIMULATOR

*This scenario adversely affected if ground refurbishment/turn around time would be 8 rather than 6 months, resulting in one-year reflight intervals due to projected SP revisit schedule by Shuttle

Figure 10. Servicing Vs. No Servicing (All-Up MEC Only)

RATIONALE FOR ON-ORBIT SERVICING

On-orbit servicing of the all-up MEC permits extension of the mission duration which will be desirable or essential for certain types, e.g., float zone processors, while other payloads that require less time in orbit can be replaced.

Principal factors favoring on-orbit servicing are the need for fewer launches of the large all-up MEC vehicle, saving transportation and ground refurbishment costs, and greater mission flexibility. There are, however, several other factors which tend to limit the potential cost savings, such as: the extra cost of providing MEC with serviceability features; more complex operations during SP/MEC revisits; and the procurement and repeated launch of a separate payload carrier (Service Support Assembly).

Preliminary assessment has shown that the advantages of the on-orbit servicing option outweigh its disadvantages and support the decision to provide MEC with the design features required for serviceability. Further assessment

tors and their impact on system design, mission profile definition cost is discussed below.

comparison was performed of two principal mission options, either one MEC with servicing on orbit (scenario 2 in Figure 9) or two alternate launch opportunities every 6 or possibly 8 months (scenario 3). The normalized cost per year in orbit for scenario 4 will be only slightly higher than that for scenario 2, i.e., about 10 percent. This is due largely to the cost of developing and flying a Service Support Assembly in scenario 2 versus scenario 4. This cost difference alone is not sufficiently large to be a basis for adopting the servicing mode, scenario 3. The impact of a more than 6 month ground turn around time on the scenario also should be taken into account. Secondly, an important qualitative difference, not reflected in the cost figures, is the fact that scenario 4 is limited in orbital stay time by the mission which may not be satisfactory for certain payloads.

To give a further explanation of this issue, consider the three MEC user populations characterized in Figure 11 by their probability distribution vs. desired orbital stay time. In population ① a majority of the users require short stay times around three months. This peak shifts in distribution ② and ③ to four months, respectively. This trend may be assessed as follows:

Payload requirements analyses indicate that distribution ② is representative of potential MEC user population (All-Up MEC).

Orbit stay time = (processing time) x (desired sample number).

Increase in sample number to reduce cost/sample drives stay time up.

Emphasis on commercial users also drives stay time up (e.g., EOS).

MEC planning should address items 3 and 5, therefore reflect distributions ② or ③ rather than ①.

Given these factors and a projected six month revisit interval, MEC stay time in orbit beyond the six-month interval length with changeout of some payloads often can be advantageous. In this manner one can satisfy users with less than six-months and those with more than six-months desired stay time equally well.

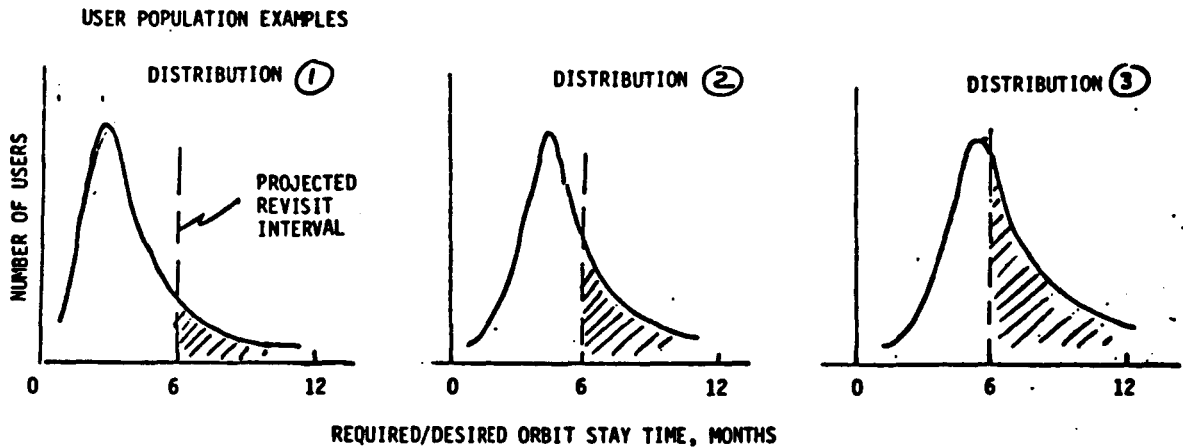

Figure 11. Orbital Stay Time Criteria (All-Up MEC)

IMPACT OF ON-ORBIT SERVICING REQUIREMENT ON CONFIGURATION AND MISSION OPERATIONS

Figure 12 lists design features required for making MEC payloads or sample magazines replaceable on-orbit. These features include not only special provisions for payload access, mounting and demounting, and for mating or demating of electrical and fluid line connectors but also the overall configuration layout. Serviceability also reflects in the arrangement of the EOS payload relative to the MEC core and growth modules, so as to permit unobstructed access to MEC payload compartments. Note that these serviceability design features do not include provisions for on-orbit repair or replacement of failed units, which would further complicate the design.

1. Axial payload attachment in core module (retained in all-up MEC) requires location at growth module aft end.
2. Also requires EOS attachment via hinged adapter.
3. Extra cable and coolant line length from SP to MEC subsystems because of aft end mounting of core module (which contains subsystems).
4. Lateral payload access in growth module dictated by location between SP and core module.
5. Growth module payloads rail-mounted to facilitate on-orbit changeout. (Sample changeout access requires further study).
6. Use of MMS-type/SP-type electrical connectors, quick-disconnects for coolant, guide pins and lead screws for mating/demating of payloads.
7. Provisions in initial MEC payload interfaces to permit conversion to on orbit mating/demating capability (item 6).

Figure 12. Impact of On-Orbit Servicing Requirement on Configuration*

*In all-up MEC only

Servicing operations require payload and component handling either by the Shuttle Remote Manipulator System (RMS) or manually, by a crewman in the EVA mode. The payload units must provide grapple fixtures and/or ahdnles for manipulation by the RMS or crewman. In addition, convenient and safe access to internal equipment must be provided via access hatches of sufficiently large size. Crew servicing also will require access support provisions on payload units and on the MEC proper, such as handholds, handrails and foot rests.

Utilization of the Teleoperator (TMS) to perform remote MEC servicing functions by transferring payloads between the Orbiter and the SP/MEC will be an alternative to Orbiter-based servicing. A principal advantage of this mode is the avoidance of SP/MEC proximity operations and berthing and consequently, any interference this may cause with Orbiter mission objectives other than MEC servicing. Also there would be no need for carrying a SP berthing adapter.

8. MISSION CHARACTERISTICS

MEC will be carried to orbit, attached to the Space Platform and deployed into the free-flying mission phase by the Shuttle Orbiter. At the end of the mission the MEC will be retrieved by the Orbiter and returned to the ground.

During extended missions the Orbiter will revisit the MEC at least once, to perform essential services such as payload exchange, processed sample exchange, or replacement of defective support systems.

MEC mission durations will be up to 180 days and longer. As many as two MEC launches per year may be performed, provided the mission durations and turn-around times between missions are short enough. A total of at least six missions shall be flown by one MEC vehicle.

The projected initial flight date will be 1986, conforming with the IOC of the Space Platform.

Dates for MEC launch, servicing and retrieval must be planned to make use of Shuttle ride sharing opportunities since MEC or the equipment used for MEC servicing will utilize only part of the Shuttle cargo capacity.

MEC-related launch dates and daily launch windows are constrained by the Space Platform rendezvous requirements. Depending on SP orbit inclination there will be one or two daily launch windows.

MEC will not restrict SP orbital characteristics in terms of altitude or inclination except for requiring operating altitudes above the level where the maximum atmospheric drag deceleration would exceed the limit of $10^{-5}g$, i.e., typically 160 n.m. (Note: SP will avoid altitudes in this region, in any case, because of large drag makeup maneuver requirements).

SP orbital characteristics preferred by MEC are those that provide (a) maximum average power and (b) convenient access by the Shuttle for deployment, servicing and retrieval. In order to get the best Shuttle cargo weight performance and to minimize transportation cost for MEC launch, retrieval and servicing, low altitude, low inclination SP orbits will be preferred. Also, since MEC depends on ride-sharing with other Shuttle payloads a greater number of launch opportunities would be available under these conditions.

Mission analysis and trades led to the definition of preferred mission characteristics. Figure 13 summarizes results of this analysis, showing a logic flow which indicates the alternatives considered and the rationale applied at each step of the selection process.

The same MEC vehicle is to be used repeatedly. After retrieval for orbit it must be refurbished on the ground and/or refitted with a new payload complement and prepared for relaunch. The estimated turn-around time between missions will be 6 to 8 months.

Generally, the mission shall include on-orbit servicing which involves a changeout of MEC payloads or samples.

Composition of the MEC payloads, required mission duration and available Shuttle launch opportunities that are compatible with targeting constraints of SP/MEC rendezvous will dictate the timing of revisits for servicing. Mission profiles with or without servicing are shown schematically in Figure 14. Mission phases and sequences are illustrated in Figure 15.

The sequence of on-orbit operations required to deploy the MEC during a Shuttle/Space Platform rendezvous mission is illustrated in Figure 16. After rendezvous, retrieval and berthing of the Space Platform on a structure provided for this purpose in the Orbiter cargo bay, the MEC will be removed from its stowed position and attached to one of the Space Platform payload berthing ports. When attached, the SP/MEC will be checked out as a functioning system before release by the Orbiter to start free-flying operations.

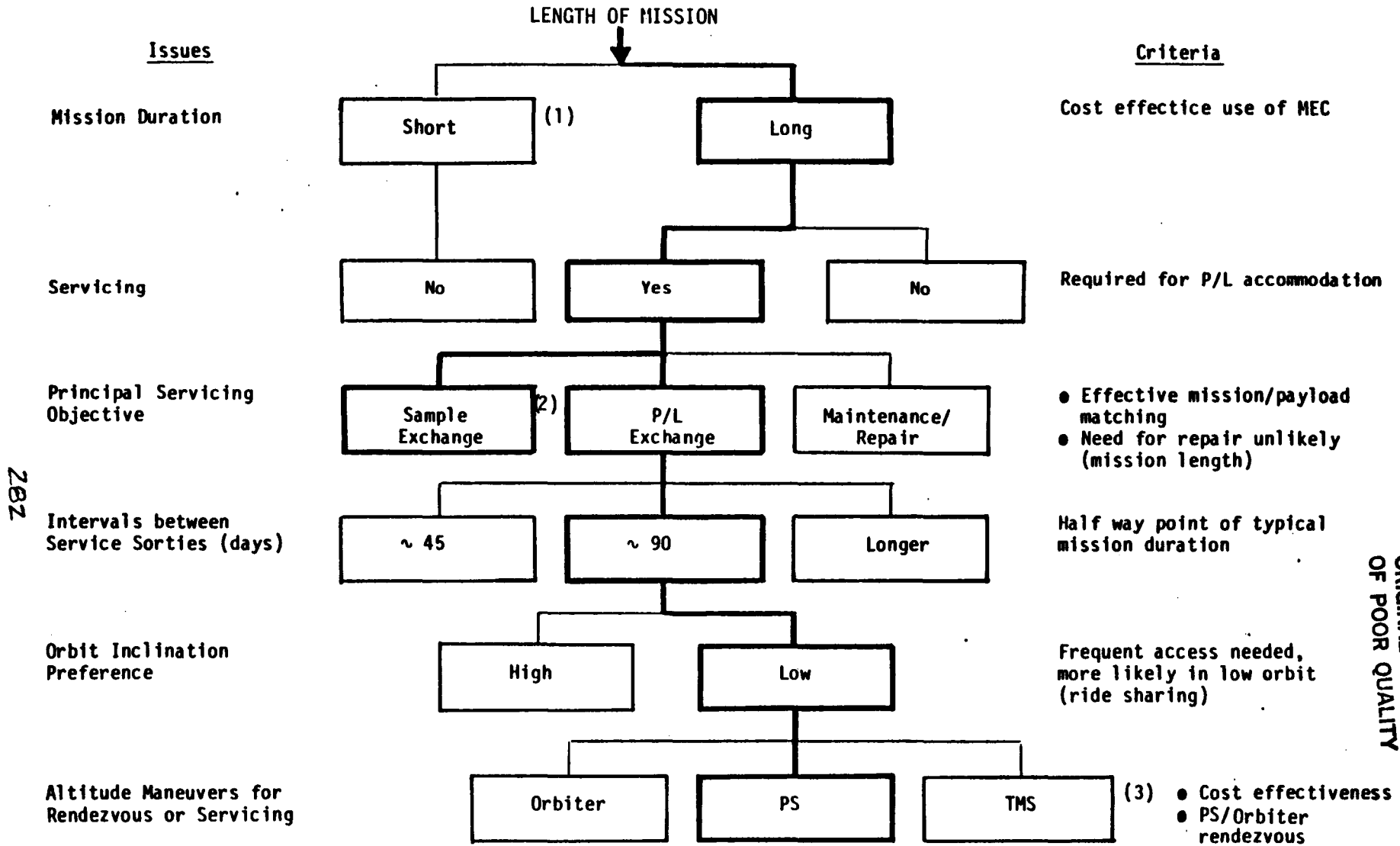

Figure 13. Mission Profile Selection Logic

282

ORIGINAL PAGE IS OF POOR QUALITY

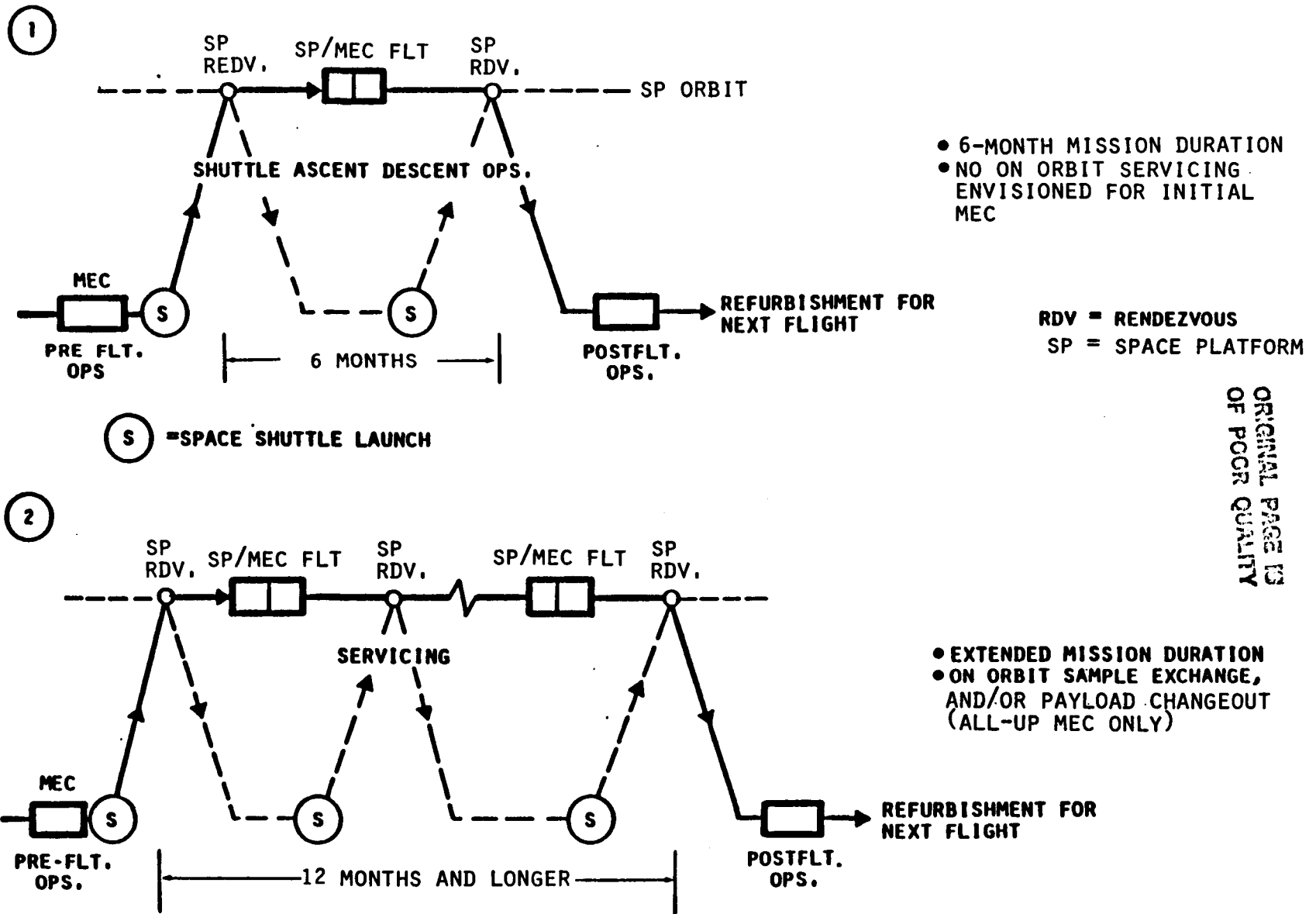
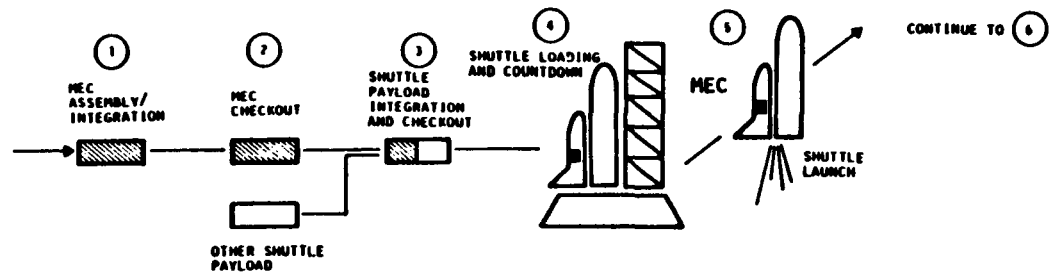
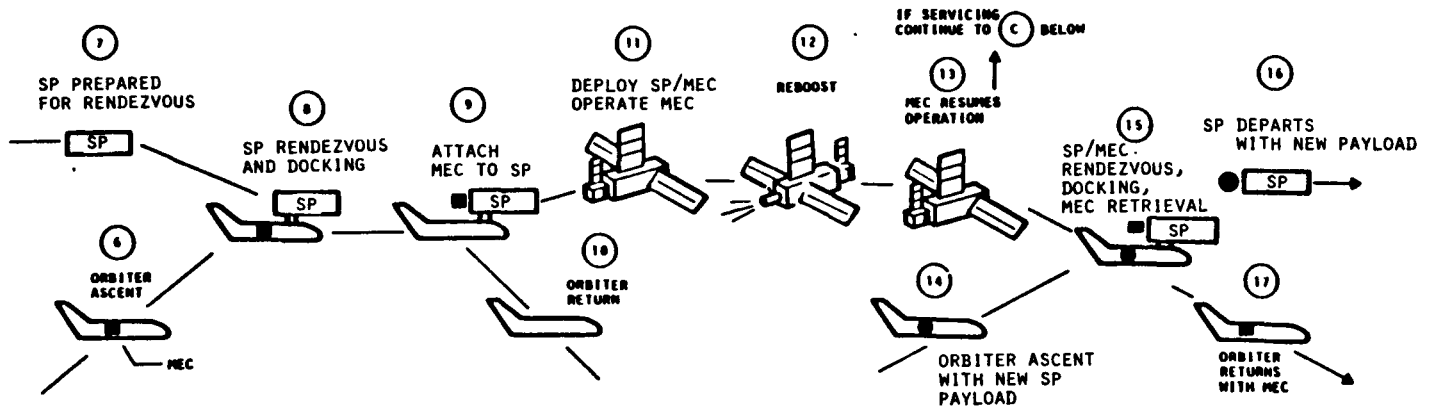

Figure 14. MEC Mission Profiles Without and With On-Orbit Servicing

PRELAUNCH/LAUNCH OPERATIONS



ORBITAL OPERATIONS - MEC BASELINE REFERENCE MISSION (INITIAL OR ALL-UP MEC)



MEC BASELINE REFERENCE MISSION WITH ON-ORBIT SERVICING (APPLIES TO ALL-UP MEC ONLY)

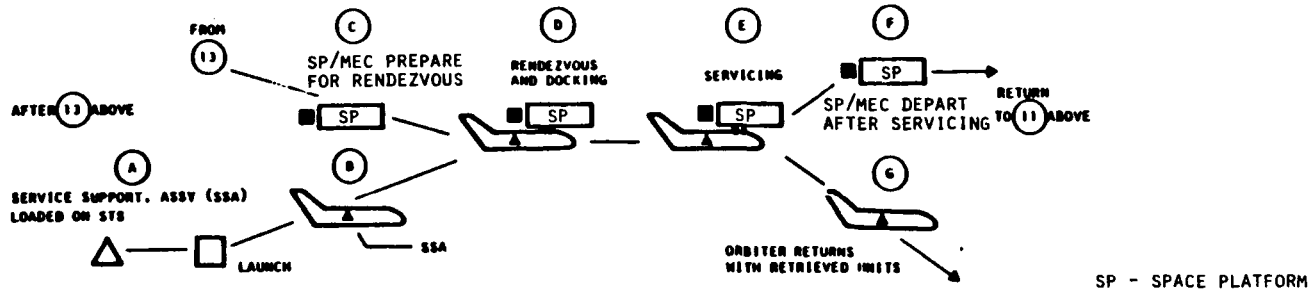

Figure 15. MEC Mission Sequence of Events

ORIGINAL PAGE IS
OF POOR QUALITY

284

ORIGINAL PAGE IS
OF POOR QUALITY

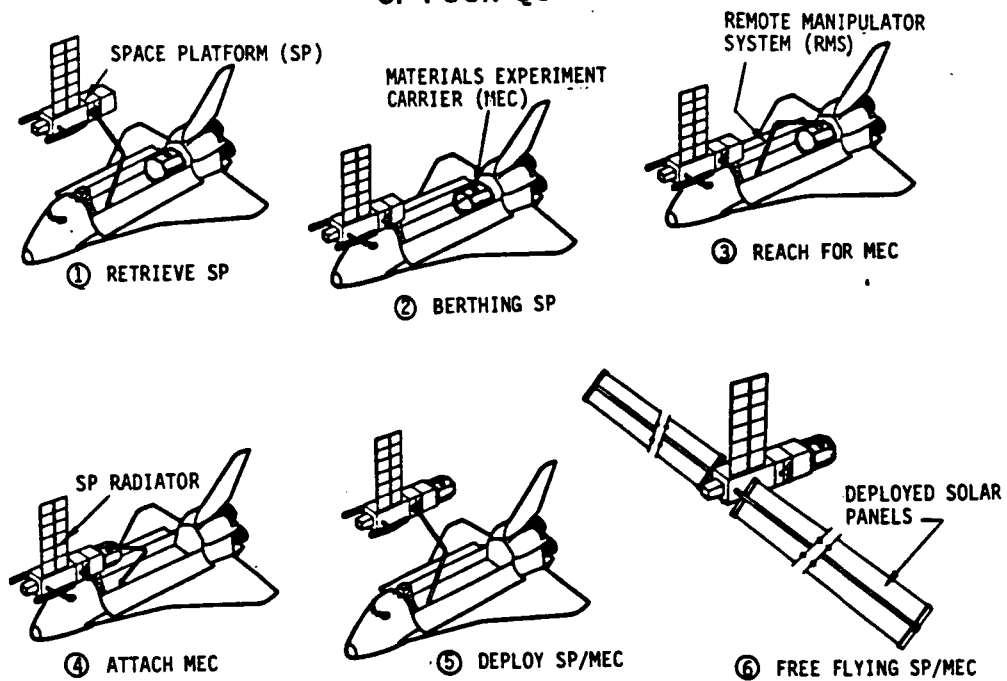

Figure 16. MEC Deployment Sequence

The Shuttle Remote Manipulator (RMS) arm will be the primary support hardware used to capture and berth the SP and to accomplish MEC unstowing, transfer and SP berthing port attachment.

Assistance by crew member extra-vehicular activity may be required as a backup in supporting the remotely controlled RMS operations. Stringent safety requirements must be observed to avoid potential hazards to the Orbiter and crew that are inherent in all phases of this activity.

Sequences similar to those shown in Figure 16 will be employed in MEC retrieval from orbit and on-orbit servicing activities.

Alternative MEC deployment, retrieval and servicing sequences may be supported by the Teleoperator Maneuvering System (TMS). Thus, the TMS may be utilized to aid in achieving Orbiter rendezvous with the SP and in redeployment of the SP or to carry MEC to or from the SP if direct rendezvous/docking of the Orbiter with the SP is to be avoided; or to carry MEC payload units from the Orbiter to the SP/MEC and back to the Orbiter in remote payload changeout (servicing) operations.

9. SERVICING MODES

Figure 17 schematically shows the three servicing modes and summarizes objectives and design impacts. Remote servicing by the TMS reduces SP/Orbiter proximity operations and berthing events, Orbiter or SP maneuvering requirements and interference with, or disruption of Orbiter and SP normal activities.

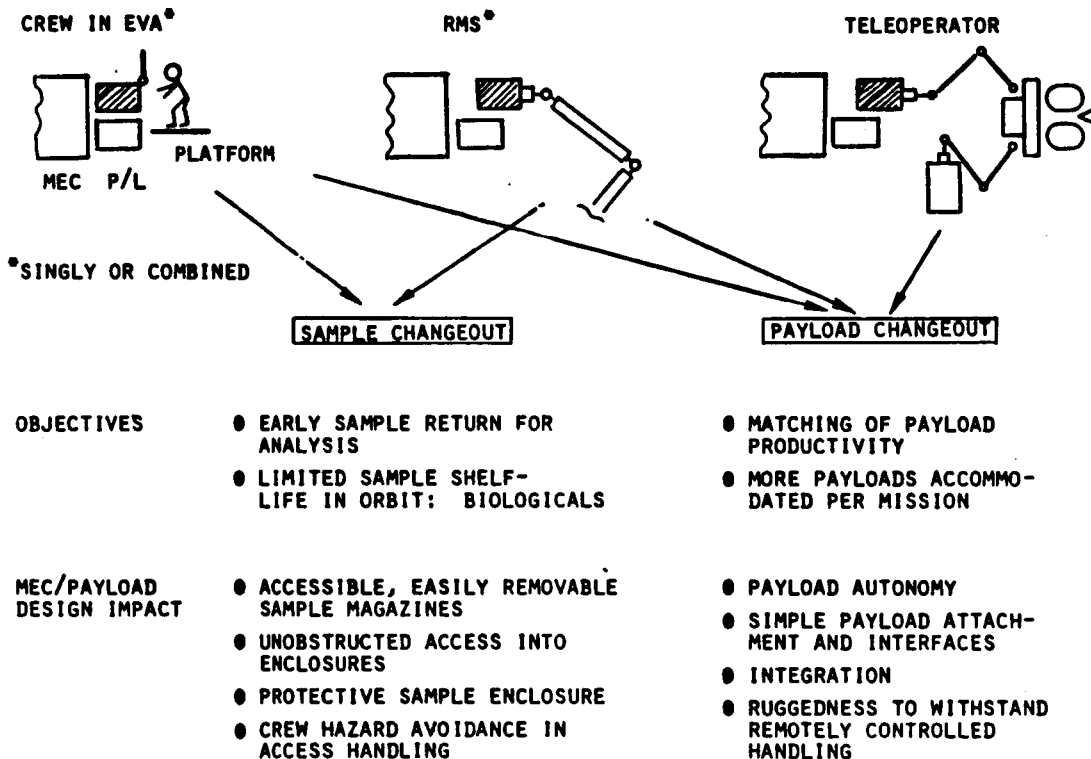

Figure 17. Alternate On-Orbit Servicing Modes

10. SERVICING COST MODEL

A simplified cost model was used to assess the potential savings achievable through servicing. It is assumed that each servicing sortie extends the orbit stay time by the length of the original mission and thus increases the total product obtained in the same ratio, at a fraction of the reference mission cost.

Figure 18 shows the reduction in "cost per total mission product" vs. the number n of service sorties flown. The cost index of the reference mission is used as normalizing parameter, that is, in the bar graphs shown its value is indicated as 100 percent at $n=0$. Key parameters in the cost model are the relative cost C of a servicing mission and the relative mission operations cost A per unit time. Servicing is more cost-effective if both of these cost fractions are low.

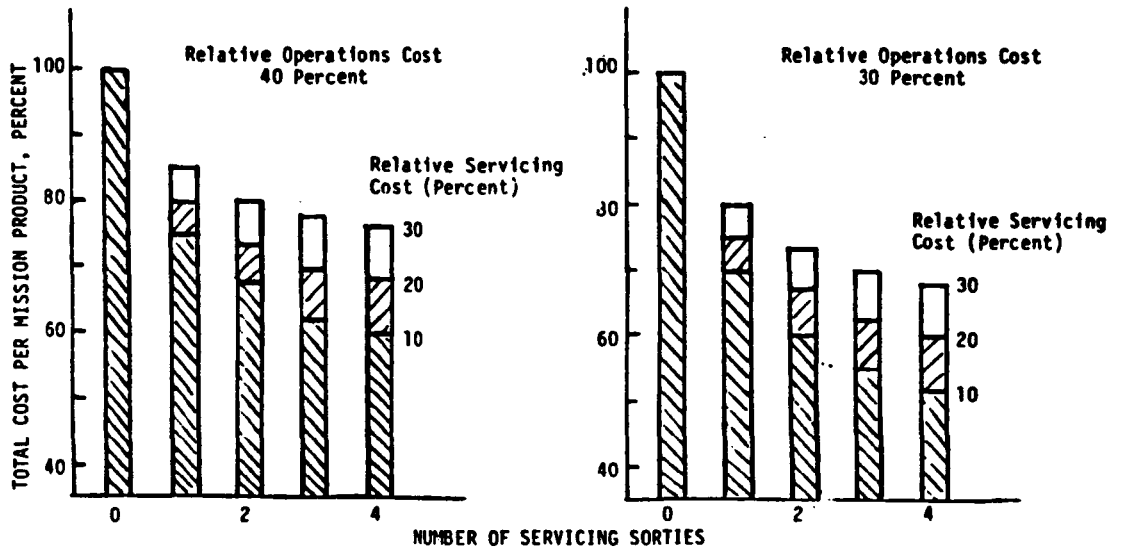

Figure 18. Examples of Cost Reduction Through On-Orbit Servicing

The bar graphs in Figure 18 represent mission operation costs of 30 and 40 percent at a reference mission duration of 100 days. Relative servicing costs of 10, 20 and 30 percent are assumed. For example, for $A=30$ and $C=20$ percent and two service sorties the cost index is reduced by 33 percent. Cost reductions of up to 50 percent are projected for $n=4$ with the largest step resulting from the first service sortie.

11. CONCLUSIONS

On-orbit servicing is a complex subject. Safety, design, mission operational factors, user needs and cost are all involved in the decision in incorporating on-orbit servicing into a space system. This presentation highlighted the issues that were subjected to study during the MSFC sponsored MEC study. Conclusions reached, during the study, are listed below:

1. On-orbit servicing will be required in all-up MEC missions to increase mission cost effectiveness, by
 - Extending mission duration and thus increasing mission output, i.e., the number of samples processed per mission,
 - Reducing the number of MEC launches and retrievals required per year, thereby greatly reducing transportation costs,
 - Achieving improved payload/mission matching, and more effective Space Platform utilization by MEC, e.g., through replacement of payload units that complete their mission objectives ahead of others
2. On-orbit servicing, like other MEC mission phases requiring repeated Shuttle/Space Platform rendezvous and docking, will involve intricate, crew supported, Shuttle operations that will gradually evolve into routine activities. This aspect of the MEC mission does not require novel technology, per se, but does involve a buildup of experience by Shuttle flight crews.
3. Payloads carried in all-up MEC missions shall have design and interface characteristics that are consistent with, and facilitate on-orbit servicing. Servicing operations will include exchange either of entire payload units or only of sample magazines within payloads.
4. Principal factors favoring on-orbit servicing are the need for fewer launches of the large all-up MEC vehicle, saving transportation and ground refurbishment costs, and greater mission flexibility. There are, however, several other factors which tend to limit the potential cost savings, such as: the extra cost of providing MEC with serviceability features; more complex operations during SP/MEC revisits; and the procurement and repeated launch of a separate payload carrier (Service Support Assembly).
5. Composition of the MEC payloads, required mission duration and available launch opportunities that are compatible with targeting constraints of SP/MEC rendezvous will dictate the timing of revisits for servicing.
6. The Shuttle Remote Manipulator (RMS) arm will be the primary support hardware used to capture and berth the SP and to accomplish MEC unstowing, transfer and SP berthing port attachment.

7. Alternative MEC deployment, retrieval and servicing sequences may be supported by the Teleoperator Maneuvering System (TMS). Remote servicing by the TMS reduces SP/Orbiter proximity operations and berthing events, Orbiter or SP maneuvering requirements and interference with, or disruption of Orbiter and SP normal activities.
8. A simplified cost model was used to assess the potential savings achievable through servicing. It is assumed that each servicing sortie extends the orbit stay time by the length of the original mission and thus increases the total product obtained in the same ratio, at a fraction of the reference mission cost.
9. Preliminary assessment has shown that the advantages of the on-orbit servicing option outweigh its disadvantages and support the decision to provide MEC with the design features required for serviceability.

1188 11190

3/6

DESIGN CONSIDERATIONS FOR ON-ORBIT SERVICING

H. T. Fisher
Space Systems Division
Lockheed Missiles & Space Co

DESIGN CONSIDERATIONS FOR ON-ORBIT SERVICING

H. T. Fisher
Supervisor, Crew Systems
Space Systems Division
Lockheed Missiles & Space Company

1.0 INTRODUCTION

The advantages of on-orbit servicing and cost benefits thereof have been well presented in the previous papers of this Workshop. Accordingly, this paper will be focused on an overview of the general design of space vehicles serviced in orbit. The basic space vehicle systems, subsystems, modules, components, and associated appendages will comprise the elements to be considered. Primary emphasis will be given to the multi-disciplinary considerations in the development of requirements, and in particular, design of the space vehicle to facilitate orbital service by the extra-vehicular crew person(s). (See Figure 1 for flight crew allocation logic). Only minimal consideration will be given to airborne support equipment as that also has been generously covered elsewhere in this workshop.

2.0 REQUIREMENTS/DEFINITIONS

For purposes of this paper, it will be assumed that the 'Customer' has established and justified the need for on-orbit servicing of the space vehicle. Thus, through the application of standard 'system engineering processes', it can be further assumed that mission, system, launch vehicle (e.g., Space Shuttle), subsystem (including crew), and interface requirements/constraints (Figures 2 through 5) have been and will be in the development and refinement stages. Obviously, heavy participation by the conceptual engineering design team will play an important role in this process, thereby assuring basic design, integration, and performance feasibility.

Requirements for servicing generally fall into two categories: (1) Planned; and (2) Unscheduled. Planned servicing includes any on-orbit functions conducted to permit continued orbital operation of the space vehicle through planned maintenance implemented by changing out equipment, reconfiguring, replenishing depleted resources, or repair on known and identifiable (pre-launch) problems. These functions are known well in advance of the flight date and the crew has been familiarized, trained, and has conducted necessary simulation for these events prior to launch. Similarly, the necessary crew aids/devices/tools and support equipment (ASE) is carried aboard the Orbiter to support the planned (scheduled) servicing.

Unscheduled servicing is associated with those functions conducted to restore the space vehicle to an acceptable level of operational status for subsequent deployment/release to space, or for recovery and insertion into the Orbiter cargo bay for earth return. This servicing could also include crew activities associated with de-orbit of a space vehicle or explicit payload. Unscheduled servicing implies that the potential for a non-nominal situation had been anticipated, thus, the flight crew had been prepared (familiarization, training,

simulation, etc.) and sufficient crew aids/devices/tools and support equipment (ASE) carried aboard the Orbiter for conduct of the task(s). These events are not planned for nominal servicing activities, but could be accommodated in the flight plan, as required.

Servicing is herein defined as being composed of five major categories:

- Deployment
- Retrieval
 - Stow
 - Berth/Dock
- Observe
- Support
 - Changeout
 - Reconfiguration
 - Resupply/Replenish
 - Repair
- Earth Return
 - De-orbit
 - Debris Collection
 - Orbiter Return

Servicing can also be categorized into the nature of the servicing function, e.g., critical, override, and nominal. Critical servicing is associated with sustaining the space vehicle and/or mission and occurs when a prime equipment item has failed or degraded and the redundant unit is on-line or also has failed, or where a principal consumable is near depletion or has been depleted. Override (Figure 6) is associated with the need to conduct a task, e.g., appendage extension, to enable space vehicle function or mission attainment. Nominal servicing is generally associated with non-sustaining space vehicle/mission functions. In this situation, servicing is frequently conducted on changeout of experiment items which have failed, degraded, or are planned to be updated (replaced with advanced state-of-the-art units or units with different functions). Preventative maintenance could also fall in this category.

3.0 APPROACH

The key to design of the space vehicle (composed of the spacecraft and payload) is to identify very early in the systems development phase of the program which items are planned to be serviced. Frequently, designers tend to 'bury' equipment, incorporate 15 to 30 connectors per box, provide special tooling for removal/replacement of components, etc., etc., etc. This is not implied to be a slap at designers, but rather they are not accustomed to designing for crew access, tool utilization, and component removal/replacement swept volumes. Thus, the next important and key element is education, and the dissemination of succinct, easily understood, and well illustrated design guidelines to assist the total systems and design team in the development and evolution of an easily serviceable system.

Figure 7 illustrates a very simplified flow diagram of a generalized methodology for the early phase of a development program. Note should be made of the early incorporation of mockups and simulation (e.g., 1-G shirtsleeve and occasional suited subjects) to aid in the design and integration of the servicing approach at the outset of the program. This is absolutely critical to assure that mid- and down-stream modifications, changes, etc., do not beset the program, resulting in major cost impacts/overruns and subsequent reduction of the degree of planned servicing.

In general, there are two classes of 'cargo' launched to orbit in the Space Shuttle which are of concern to this paper: these two classes are: (1) Sortie Payloads and (2) Free Fliers. Not included is the assembly/construction class. Sortie Payloads are generally considered those payloads which are

launched in and stay with the Orbiter throughout the total mission phase to be subsequently returned to earth still mounted in the cargo bay. Free Fliers are those spacecraft or payloads which are launched in the Orbiter and subsequently deployed to orbit after which they may stay in a low earth orbit, be transferred to higher orbits, or launched out of the earth's gravitation field. Certain of the free fliers are recoverable by the Orbiter and thus, can be serviced or returned to earth for subsequent refurbishment. Figure 8 presents a generalized portrayal of the on-orbit disposition of space vehicles/payloads and potential earth return.

When only a single space vehicle is being procured and subsequently developed, extreme care must be given to the manufacturing aspects of the program. In particular, if spares (items to replace equipment already in orbit) are to be developed after the launch of the space vehicle, and there is no 'duplicate full-scale hard critically dimensioned mockup', then master tooling becomes a critical issue. Furthermore, this tooling must be identified during the proposal phases and developed prior to space vehicle launch. Almost never are there sufficient funds to develop the spares on the initial contract; thus, relegating their purchase to the 'operational phase' when additional out-year funding becomes 'available' dictates the need for master tooling during the initial contract.

A second major issue is the use of 'off-the-shelf equipment'. As the number and variety of space vehicles increases, so, too, will the number of subsystem equipment items. Thus, off-shelf equipment potential applicability across the programs becomes greater and the need to accommodate them grows ever more steadily. Accordingly, design for on-orbit servicing of these 'off-shelf' items very frequently requires early recognition and more often than not, the incorporation of supplemental hardware to permit their changeout on orbit, or override, depending on the item.

Many other key and lesser key issues will be presented in the following paragraphs relative to program and system/design concerns and considerations in design for on-orbit servicing.

4.0 BERTHING

An extremely important consideration in the design of the space vehicle for on-orbit servicing is the basic accessibility of same relative to conduct of the servicing function(s). This implies that the airborne support equipment (ASE) need be carefully considered in developing the servicing approach, and can provide a viable base for servicing functions, together with the crew equipment/aids/tools. It is recognized that the servicing on-orbit will grow from Orbiter based activities, thence to 'near orbiter', obviously then to the SOC/SAMSP concept, and finally to high earth orbit (HEO).

Since this paper is primarily addressing Orbiter support for servicing, the use of berthing systems to augment the EVA tasks is crucial to the practicality, timelines, and safety of the servicing operation. To that end, a number of devices have been proposed (as evidenced in this Workshop), such as the MMS program's Flight Support System (FSS), Holding and Positioning Aid, and the Deployment and Maintenance Platform (DMP). Figure 9 illustrates an example of one of these devices.

The use of such a device significantly drives the methods for changeout of items, and therefore, the design of the basic space vehicle as well as the items to be replaced on orbit, e.g., line replaceable units (LRU's) or Orbital Replacement Units (ORU's). Furthermore, selection of the berthing device also affects the servicing approach/scenario, spares (LRU's or ORU's) containment, other ASE as required, and associated crew equipment/tools/aids.

Additionally, the berthing device significantly impacts the design of the space vehicle relative to: (1) Berthing 'pins', (2) Load paths, (3) Structural support, (4) Dynamics, (5) Targets, (6) Tooling, and (7) Interfaces. The interfaces are not insignificant and include such considerations as power, signal, fluid/gas transfer, and mechanical. Also, the interface to and with the Orbiter can be equally significant and includes such considerations as mounting to the sill and keel fittings, power/signal interfaces and connections, swept volumes and cargo bay envelope, thermal blockage (items overhanging the radiators), weight and CG factors, etc.

Thus, methods of 'holding and articulating' the space vehicle become very important as they relate to the overall system integration and interface issues. The consideration, therefore, of providing a 'berthing interface' on either the front or aft end of the space vehicle must be examined early in the conceptual phases to determine potential impacts and to ascertain the significance of the interfaces as they transcend the total servicing approach.

5.0 SPACE VEHICLE DESIGN FOR SERVICING

5.1 General

Design for on-orbit servicing in and of itself is not a new concept. Studies such as those conducted in the mid-1960's (MORL, LORL, MOL, AAP (Skylab), BIOLABS, Orbital Station, etc.) did not deal with the zeal and impact of the more recent programs, i.e., the Multimission Modular Spacecraft (MMS) and the Space Telescope (ST). The former program was designed for changeout of a discrete number of modules, while the ST provided the potential for changeout of over 100 ORU's via the EVA mode. The key in both of these example programs was the early determination of the need for and commitment to the on-orbit servicing approach and the incorporation of design methods to achieve this objective.

5.2 Space Vehicle

The initial conceptual design approach begins with the identification of those LRU's or ORU's which are to be considered for changeout on-orbit. Therefore, the examination of the basic space vehicle subsystems is necessary (Figure 10), and a rational decision made as to what need be changed out as a function of several factors including: (1) Reliability and MTBF factors, (2) Items highly suspect to malfunction but with limited flight reliability data, (3) Preventative maintenance considerations, (4) Wear-out lifetimes, (5) Degradation lifetimes, (6) Items which may receive inadvertent collateral damage, (7) Items subject to EMI or other 'signal' spectra damage, (8) Induced damage, e.g., loss of thermal control and subsequent change of temperature past survivability level, (9) Micro-meteorite penetration/damage, (10) Cascading failures or power surges, (11) Equipment/experiment item update/replacement, (12) New payload replacement, and (13) Complete subsystem replacement, etc.

Once the items to be changed out on-orbit have been initially identified, the next step is to identify a set of 'core' design features (Figures 11 and 12) to apply in the layout and design of both the space vehicle structure itself as well as the basic subsystems (Figure 13), including the LRU's or ORU's, and the associated interfaces, mounting provisions, cables, thermal protection, etc. Thus, the consideration of the application of design features (Figure 14) must be identified for the entire range of development activities and appropriately incorporated (and costed) for both on-orbit servicing and ground element implementation as well. Allocation of design features is an important early function since more than just the space vehicle is involved in an interface and integration sense. This becomes critical, relative to the need for close liaison between space vehicle development activity, subsystems and related on-going functions concerned with ASE development, crew support aids/equipment definition, and the critical interface with the Orbiter, both physically and functionally (including procedural interactions).

As expected, documentation plays a pivotal role in completion of the design features. All contractors have an existing and very formal set of hardware development documentation; a tried and proven set of approaches/methods very carefully employed, followed, checked/verified and documented. Similarly, the customer (NASA/DoD) also have sets of documentation (including program specific) which must be rigorously followed. Early examination and correlation of these two sources of documentation is very critical, both from an implementation (cost) and practicality standpoint. These documentation sources (Figure 15) which frequently differ (occasionally significantly), must be examined at the outset of the program, particularly as they relate to the space vehicle design service features. Often, these design features include approaches (e.g., dimensions which are not standard manufacturing practices), and therefore require early resolution to minimize cost and schedule impact.

A prime example of a dimensioning concern is the NASA required corner and edge radius for all equipment and structures with which the EVA crew person may come in contact during the servicing function. Obviously, these dimensions are not standard manufacturing practices and, by necessity, must be negotiated, identified, and cost increments specifically delineated.

It must be stated that the design process is an iterative one and as the maturity of the design progresses, continued review, revision, amalgamation, and standardization of the design features evolves. Inherent in the process is the necessary education of not only the designers, but also the systems team members, basic subsystem designers, etc., and as importantly (if not more so), the Program Office and Management Team. This latter cadre of personnel generally are not always fully responsive to the added effort, liaison, and the necessary interface meetings required to proceed with the design of items for on-orbit servicing. And often, certain of the customer program personnel are not fully acquainted with the necessary elements for design of the space vehicle and equipment for on-orbit servicing, thus, necessitating in certain instances the need to assist them in understanding the nature and significance of the objectives and design approaches. Herein, the enlistment of the NASA Astronauts and Air Force Manned Spacecraft Engineers (MSE's) can be of tremendous value in bringing the necessary high level attention to the particular problem or concern.

5.3 Mockups and Simulation

Very early in the program, preferably in the conceptual phases, introduction of models and mockups to aid in portrayal of the systems and engineering effort, ideas, approaches, and interfaces is most necessary. The early mockups can be of simple construction employing Fomcor as the basic material and, accordingly, a material that the engineers can work with without concern for a 'union grievance' - a most important consideration! Initial mockups can be table top items subsequently progressing throughout the following general steps (although not necessarily in this order):

- Models (1/50th to 1/20th scale)
- Small scale wood, plastic, and/or Fomcor representations
- Full scale wood, metal, and/or Fomcor mockups of selected areas/items
- Full scale hard mockups of partial space vehicle segments or equipment constructed of wood, metal, and Fomcor
- Full scale hard mockups of items wherein certain features are functional to a specifically limited degree; various materials are herein used
- Full scale hard mockups of space vehicle elements, e.g., payload, spacecraft (housekeeping) section, and major appendages; various materials
- Full scale hard mockups of space vehicle elements used for engineering test bed; various materials
- Full scale soft and hard mockups (part task trainers) used for crew systems activities and verification/training
- Full scale hard mockup replica of space vehicle ranging from non-functional to fully functional; various materials
- Full scale hard mockups for water immersion, KC-135 flights, etc.

The development of mockups is, without doubt, one of the key elements in the implementation of the servicing approach and, obviously, attendant design of the space vehicle and associated items for changeout in addition to the ASE, interfaces to/with the Orbiter (or Space Station), and the functional/procedural aspects. The prudent and early use of mockups can and does result in significant overall program savings measured in terms of engineering time, smoothed integration, more simplified definition of interfaces and requirements, earlier 'verification', greater and earlier crew acceptance, less re-direction and re-design, and increased awareness of manufacturing to the explicit development needs and tooling.

Simulation also plays a vital role and begins with the earliest development of the full-scale mockups. General simulation activity categories are as follows:

- 1-g shirt sleeve
- 1-g suited
- KC-135
- Water immersion

Suited simulation is, obviously, more costly than shirt sleeve activities. This is of course due to the increased support team and necessary safety aspects. Water immersion (neutral buoyancy) simulation is more costly yet, however, for certain crew interface, functional task accomplishment, and fidelity requirements, water immersion simulation is nearly mandatory. Experience shows that for crew tasks associated with space vehicle servicing which are conducted

'in situ' or in a specific location wherein crew translation from point to point is not needed, 1-G suited simulation is nearly always acceptable. Additionally, 1-G simulation is considerably less costly, thereby making it a highly useful and cost effective method to conduct: (1) More frequently, (2) Earlier on in the program, and (3) Involving the astronaut community earlier. For tasks requiring manual manipulation of large items (not fully restrained or coupled to a 'rail system'), or when significant translation from point to point is required, there is generally no substitute for water immersion suited simulation.

The key to use of mockups and simulation is the effective participation of the systems, integration, and design team members as parties to the simulation which has been set up with specific objectives to be met relative to the design or integration factor under consideration. The simulation should not always be crew systems specific, but rather carefully tailored to meet the multi-disciplinary needs of the total program team. For example, typical engineering uses of the mockup during simulation runs include examination, assessment, and evaluation of the following:

- Black box/component layout and arrangement features and interfaces
- Power/signal cable layout, bend radii, potential interferences and paths
- General connector access
- Handling methods for demated connector/cables
- Grounding strap runs/paths and handling techniques
- Basic mounting technique access, arrangement, grounding & thermal interfaces
- ASE interface examination, access, and mounting
- Fluid transfer line layouts, vulnerability, connector interfaces
- Door/cover hinge locations, mounting, open/close features and 'tie-down'
- Protrusions, sharp corners/edges potential, and snag features
- Areas wherein crew loads are imposed - purposely and inadvertently
- Multi-layer insulation (MLI) layup, tie down, and crew impact vulnerability
- Removal/replacement swept volume envelopes & collateral damage assessment
- Basic safety features and provisions
- Potential hazard identifications
- Mounting location identifications and feasibility determinations
- Critical module/component mounting and alignment

Thus, as evidenced in the aforementioned mockup and simulation uses, a total program team utilization approach is vital. And lastly, it can't be emphasized too greatly that the earlier the total team begins to participate in mockup use and even simplified crew simulation exercises (shirt sleeve), the greater the payoff to the program.

5.4 Specific Design/Integration Considerations

It is not the intent of this paper to be presumptuous and pretend to tell designers how to design. Rather, it is intended to inform the designers of many of the multitude of factors which must be 'emphasized' and/or included during the design and layout of the space vehicle to be serviced on-orbit. These factors must also flow from system inception through fabrication and ultimate test and verification. The following paragraphs shall attempt to identify some of the more important factors as they relate to overall design and integration.

5.4.1 General Accessibility

This set of considerations includes concern not only for the on-orbiting servicing requirements but should give reasonable attention to manufacturing, assembly, test, verification, and integration. Primary emphasis is given, however, to those considerations most pertinent to design for on-orbit flight crew EVA servicing.

- A. Design for 5th percentile female to 95th percentile male
- B. Suited crew motion, reach, and visual anthropometrics (Figure 15)
- C. Tool swept volume utilization
- D. Removal and replacement access and swept volume envelopes
- E. Tool insert and engagement access
- F. Visual access with and without head/body movement
- G. Illumination path(s) to work site
- H. ASE installation/integration access
- I. Protective devices (e.g., cover) access, stowage, and remove/replace swept volumes
- J. Demated connector/cable management and positioning 'out-of-the-way' temporary restraint and handling
- K. Motion of appendages (swing/rotation, etc.) and crew locations/access
- L. Large item transfer/translation/transport and crew access/safety
- M. Access around or through structure and adjacent items
- N. Visual access to guides, rails, alignment aids, etc.
- O. Access to fasteners, hold-down/release devices, clamps, etc.
- P. Access to umbilicals, e.g., overrides, demate/remate features

5.4.2 Equipment Mounting

This area includes a host of potential design features which can be significantly influenced by design for on-orbit servicing. Further, the range of impact can include such major considerations as determining overall space vehicle diameters, basic 'internal compartment' vs external equipment mounting, load carry doors vs structure, etc. Of necessity, this element must be considered at the beginning of the concept layout stage, and the candidates carefully traded off as the requirements and definition become more firm. Herewith, are a series of typical items to consider in equipment mounting:

- A. Large item (LRU or ORU) location in relation to design for changeout:
 - Mounting orientation
 - Volume - size
 - Removal/installation swept volume
 - Cable routing
 - 'System interface'
 - Loads
 - Isolation
 - Environ. Protection
 - Alignment
 - Hold-down techniques
- B. Basic LRU or ORU installation and crew interaction
- C. Loads to or on structure (basic) or doors
- D. Grounding as it may affect changeout techniques
- E. Thermal interfaces as they relate to mounting techniques for on-orbit changeout
- F. Proximity to associated equipment(s)
- G. Shock or vibration and associated attenuation techniques
- H. Alignment features-coarse and fine for items to be changed out on-orbit
- I. Center of gravity and mass arrangements as they relate to changeout potential

- J. Installation and removal features for both ground and on-orbit
- K. 'Plumbing' routing and interfaces particularly for on-orbit ORU's
- L. Mounting footprint vs removal devices and access potential
- M. Collateral damage potential during changeout on-orbit
- N. Positive registry/guides for placing/positioning/remove/replace tasks
- O. Features for 'quick' removal associated with items to be jettisoned
- P. Elimination of sharp edges/corners/protrusions to eliminate suit damage

5.4.3 Cables/Harnesses and Layout

Design for cables and harnesses takes on a new perspective when designing for on-orbit changeout or replacement. These elements can no longer be routed, 'nailed-down', hidden, bundled in massive runs, etc., leading to inaccessibility or non-flexibility of bending in the case of door (hinged) mounted LRU's or ORU's. Furthermore, certain LRU/ORU items may be externally mounted thereby exposing the cable or harness assembly to environmental impact heretofore not encountered as they previously may have been routed underneath structure or external features. The following items are typical of those which must be considered in design for on-orbit servicing:

- A. Cable/harness motion due to location on hinged elements (Figure 18)
 - Flexing
 - Strain and relief
 - Damage exposure
 - Length
 - Connector access
 - Size/diameter vs flexing
- B. Methods for the crew person to reposition the cable/harness and temporarily stow during LRU/ORU changeout
- C. Coding of cables/harnesses and associated connectors
- D. Connector design to permit gloved mate/demate
- E. Reliability associated with cable/harness flexing
- F. Protective features relative to ground/flight crew inadvertent contact
- G. Protection (as required) against environmental impact
- H. Captive screws and fasteners (used to secure cables/harnesses) which do not create snag, tear, rip potential for the suit
- I. Connector 'protection' when not interconnected, e.g., during changeout

5.4.4 Removal and Replacement

A host of considerations are involved in design for the changeout of an item on-orbit. Often these changeout features are somewhat peculiar to the item and the location within or on the space vehicle. Also, the item to be changed out may have certain unique features which substantially impact the method for changeout. And finally, the actual ASE to be used in the changeout process may also interact with and drive the changeout methodology. Following are a composite of typical factors to consider:

- A. Removal swept volume envelope
- B. Guides and/or rails to aid in removal or insertion
- C. Tool access to fastening device
- D. Handholds/handrails for EVA crew person grasping, holding, positioning
- E. Tether attach points (e.g., 'D-rings')
- F. Protection of sensitive 'areas' to damage potential
- G. Guide or rail interface engagement and design feature(s) on the LRU/ORU
- H. Unique ASE attachment or engagement features
- I. Elimination of sharp edges/corners/protrusions of both LRU/ORU and basic space vehicle and ASE

- J. Unencumbered removal and replacement transfer path/volume
- K. Door or cover access envelope for 'pass-through' of item
- L. Method of handling during the transfer process as it relates to both the LRU/ORU and ASE (Figures 19 and 20)
- M. Illumination to facilitate crew vision during the changeout task
- N. C-G of the item and its basic mass distribution to be taken into account during the changeout task
- O. Basic size of the item to be changed out:
 - Crew handling - 'See-around'
 - Crew transfer - Shape vs mass/CG distribution
 - Handling aids - Handling aid locations
- P. Connector and grounding strap mate/demate - remove/replace
- Q. Captive vs 'loose' fasteners

5.4.5 Safety and Crew Considerations

Safety is a key design factor when, and in particular, considering the on-orbit flight crew. Safety encompasses not only the space vehicle but the ASE, the basic Orbiter, and the integration of the aggregate of hardware into the operational system which also includes procedures, software, and 'firmware'. Crew considerations transcend the entire orbiting element including the Orbiter itself. Two major design guidelines are available for major crew system design and integration considerations, and are:

- SHUTTLE EVA DESCRIPTION AND DESIGN CRITERIA, May 1976 (Under Revision), JSC-10615, NASA-JSC
- MAN/SYSTEM REQUIREMENTS FOR WEIGHTLESS ENVIRONMENTS, Dec. 1976, MSFC-STD-512A, NASA-MSFC

Since both of these documents cover 'crew considerations' fairly well, it is proposed to leave this area to the reader through reference to both of these two documents (guidelines). Safety is also called out in both documents, as well.

Design for safety includes a range of responsibilities and subject areas. Accordingly, a synopsis overview of the subject areas is included which will then necessitate that the systems, integration, design, test/verification, and simulation team member further expand this list as required.

- A. General safety considerations (Figure 21)
- B. Operations safety
- C. Crew induced loads and potential collateral damage
- D. Equipment design safety factors
- E. Structural design safety factors
- F. Airborne support equipment safety factors
- G. Electrical design considerations
- H. Explosive, nuclear, pyrotechnic, jettison considerations
- I. Shrouds, coverings, insulation, thermal blanket considerations
- J. Protrusions, edges, contours, corners, surfaces considerations
- K. Equipment transfer/transport/handling considerations
- L. Life support considerations
- M. Procedural and interface safety factors
- N. Fluids/gasses transfer safety
- O. Crew tethering
- P. Mass handling and constraint

A general top-level safety document relative to the STS has been re-issued by the NASA. This document is SAFETY POLICY AND REQUIREMENTS FOR PAYLOADS USING THE SPACE TRANSPORTATION SYSTEM, dated 9 Dec. 1980, NHB 1700.7A, Rev. A, NASA-HDQ. Although developed as a general safety policy document sufficient data exists therein to provide tangible substance to developing more detailed safety design guidelines and requirements.

5.4.6 Reliability and Spares

Although reliability is beyond the scope of this paper, something must be stated on this subject due to the major interplay between reliability and selected items for changeout/replacement on orbit. A general breakdown of the reliability tasks as they relate to providing the necessary information for LRU/ORU identification is as follows:

- A. Establish desired on-orbit lifetime design goal
- B. Identify critical and non-critical items
- C. Establish subsystem/equipment/component reliability lifetimes
- D. Determine MTBF's for candidate equipment and components
- E. Identify candidate LRU or ORU items
- F. Aid in identifying spares approach based on A-E above
- G. Assist in specifying service timelines and candidate mixes of spares

Obviously, the aforementioned reliability tasks are not fully representative of the reliability program, but rather tend to indicate the integral participation of this discipline with the design for servicing effort previously discussed.

Identification of spares becomes critical to the program based on overall sizing and cost factors. Additionally, depending on the overall configuration of the LRU or ORU, and the constituent elements thereof, spares (or replacement units) can become a major program driver, particularly relative to cost. A suggested and greatly simplified approach to this effort which is in absolute unison with the design and reliability efforts is presented as follows:

- A. Aid in the identification effort of candidate LRU or ORU items
- B. Assist in determining single vs multiple components for the LRU/ORU
- C. Provide cost estimates for the various single/multiple LRU/ORU mixes
- D. Examine impact of developing spares to match LRU/ORU mix
 - Sizing/weight
 - Handling
 - Hardware availability
 - Longevity of manufacturer
 - Storage and downstream availability
 - Quantity of items and mixes
 - Cost paths
 - Redundancy potential

Needless to say, the spares development approach is not as simple as briefly identified; nonetheless, it is an important element in the overall design process.

5.4.7 Integration

This area, perhaps of all, is the most fluid and elusive to pin point discrete tasks. However, it is critically important to the general design effort as it relates to many connected and oft-times seemingly unconnected elements. The integration effort should be part of the systems and design team and be represented at all appropriate contractor, subcontractor, and customer meetings. Frequently, these meetings are referred to as Interface Working Groups (IFWG's) and generally drive out basic issues, concerns, constraints, and problems. Thus, the IFWG team members share in exposure of these factors and directed assignments and completion dates can be made to resolve same.

Orbiter integration should become more 'standardized' once the OFT series is complete and the main line vehicles become operational. However, there still may be significant differences between vehicles and, as such, integration will continue to play an ever-important role.

Integration of the payload and spacecraft into the overall space vehicle also provides a major effort. Subsumed within this task is equipment/sensor, experiment, consumable, etc. integration along with the standard interface features. Crew 'integration features' must also be considered as must be the ASE interfaces complimented by the Orbiter interfaces (mounting, power/signal, fluid/gas, etc.).

Procedural, operational, software and firmware interfaces and integration are also pertinent to the integration process as is the ground cycle. The ground elements include mission control, ground integration at KSC or VAFB, and any integration associated with hardware/systems, etc. which meet or integrate outside of the prime contractor(s) facility such as at the launch site. Each of these phases has some measure of involvement with on-orbit servicing and obviously include spares and subsequent installation of ASE for the servicing flights.

6.0 SUMMARY

The intent of this paper has been to discuss design for on-orbit servicing. It is hoped that, by now, the reader will have some comprehension of the overall top-level consideration involved and the absolute need for a total team approach to this systems, design, integration, and verification process.

Spares definition, reliability and integration are elemental to the design process and should be incorporated from the conceptual stage onward. And finally, safety must be considered each step of the way.

A methodical and well-developed program plan for an orbit servicing design should be prepared and detailed milestones developed to ensure adherence to the plan. Liberal use should be made of the many excellent documents in this area; however, it should be noted that many should be used as guidelines only, thereby allowing the systems, design, and integration team the necessary latitude for interpretation and flexibility needed to develop a viable and cost-effective serviceable space vehicle.

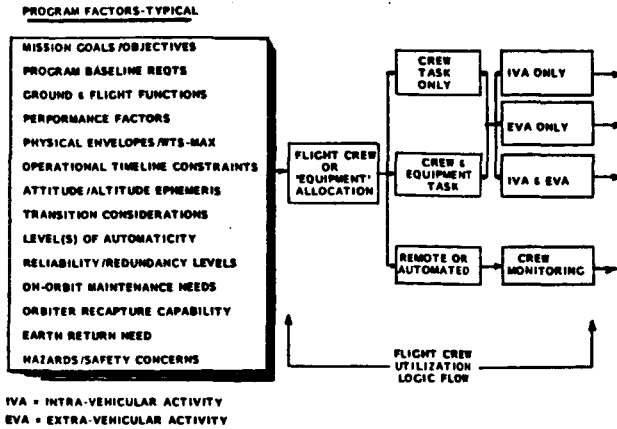

FIG. 1 FLIGHT CREW UTILIZATION (ALLOCATION) LOGIC

PHYSICAL

- SUIT ENCUMBRANCES
- STRENGTH
- PHYSICAL OUTPUT DURATIONS
- BTU OUTPUT MAXIMUMS
- ANTHROPOMETRICS
- DEXTERITY/MANIPULATION
- CONTAMINATION OUTPUT
- VISUAL ACCESS LIMITS
- MASS HANDLING LIMITS
- PRODUCTIVITY RANGES
- POSSIBLE INCAPACITATION

PROCEDURAL OPS

- PROCEDURAL DIFFICULTY/COMPLEXITY
- EXTENSIVENESS OF PROCEDURE
- TIMELINE AVAILABLE - EVA
- NO. OF EVA CREWPERSONS
- SAFETY/HAZARDS
- COMMUNICATIONS AVAILABILITY
- TRAINING LEVELS ACHIEVED
- WORK/REST CYCLES
- CREW ACTIVITY PLANNING COMPLEXITY
- PROCEDURAL COORDINATION/INTERFACE

FIG. 4 CREW IVA/EVA CONSTRAINTS - TYPICAL

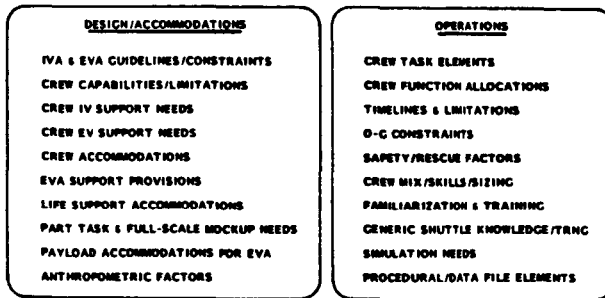

FIG. 2 CREW REQTS DERIVED FROM DESIGN/OPS ELEMENTS

- EXTERNAL SURFACE CHARACTERISTICS - GLARE
- EVA MANUAL OVERRIDES - AVAILABILITY
- EVA CREW TRANSLATION/STABILITY AIDS - AVAIL.
- STRUCTURAL ADAPTABILITY TO EVA INDUCED LOADS
- EVA COLLATERAL DAMAGE POTENTIAL
- APPENDAGE JETTISON CAPABILITIES/FEATURES
- CONTAMINATION SENSITIVITY TO EVA EFFLUENTS
- EVA & VISUAL ACCESS TO CRITICAL MECHANISMS
- BERTHING/DOCKING/GRAPPLE FEATURE AVAILABILITY
- EVA SAFETY HAZARDS

ORBITER	FLIGHT FACTORS
A. IN/NEAR BAY ILLUMINATION AVAILABILITY	A. DAY/NIGHT ILLUMINATION CYCLES
B. SURFACE REFLECTIVE CHARACTERISTICS - GLARE	B. ORBIT ALTITUDE/INCLINATION VS RADIATION
C. CCTV & WINDOW VIEWING LIMITS	C. PROPULSION USE - PLUME EFFECTS
D. COMMUNICATIONS INTERFERENCE	D. ATTY. CONTROL SYS. USE - MOTION/LOADS INDUCED
E. THERMAL RESTRICTIONS	E. STATION KEEPING LIMITS VS EVA CREW DISTANCE
F. CONTAMINATION/EFFLUENTS	F. PROXIMITY OPERATIONS EFFECTS
G. CARGO BAY ENVELOPE VS S/C (IN-BAY) RESTRICTIONS	G. ORBITER MOTION VS COUPLING TO SERVO CONTROL PLTFRS
H. S/C, EQUIPMT. & CREW AID INSTALLATION LOCATIONS	H. FLIGHT CREW 'HOUSEKEEPING' MANDATORY TIMELINES
I. AIRLOCK REPRESURIZATION LIMITATIONS (QUAN.)	I. HEAT REJECTION VS S/C PROXIMITY
J. ORBITER PROVIDED SUPPORT/CONSUMABLES LIMITS	J. ON-ORBIT MISSION DURATION

FIG. 3 ORBITER AND FLIGHT CONSTRAINTS - REPRESENTATIVE

- REPAIR FEASIBILITY/ACCESS
- ALIGNMENT FEATURES - EVA COMPATIBLE
- EVA ALIGNMENT FEATURE 'OVERRIDE'
- ALIGNMENT TOLERANCES - EVA ATTAINABLE
- ADJUST. ALIGNMT. FEATURES - EVA WORKABLE
- LARGE ITEM REPLACEMENT PRACTICALITY
- POWER ISOLATION FOR EVA
- SUSCEPTIBILITY TO EVA MOTION DURING ALIGNMT.
- SIGNAL/PWR CABLE MGMT. - EVA UTILITARIAN
- TRANSLATION (EVA) PATH SAFETY ROUTES
- SIZED TO PERMIT 5TH TO 95TH STILE EVA CREW ACCESS

FIG. 5 S/C EVA CREW DESIGN CONSTRAINTS - TYPICAL

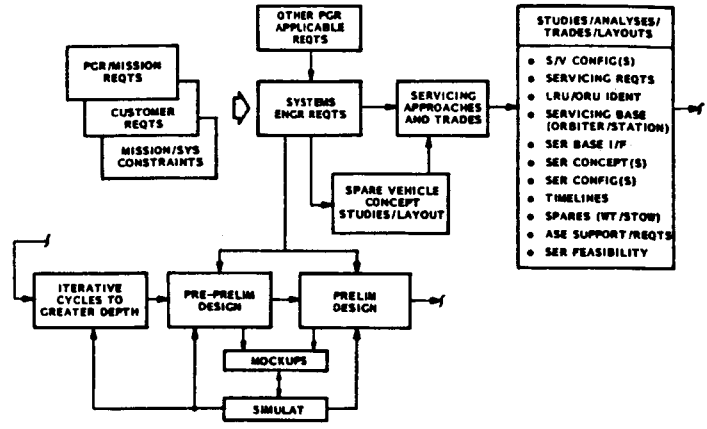

FIG. 6 DESIGN STUDY
FLOW & I/F DIAGRAM -
TYPICAL

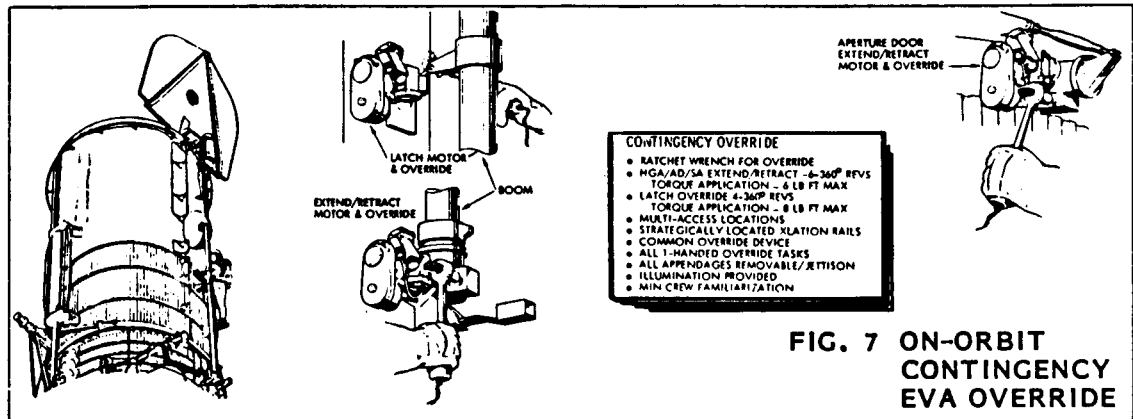

FIG. 7 ON-ORBIT
CONTINGENCY
EVA OVERRIDE

FIG. 8 SERVICE
ELEMENT
INTERACTION

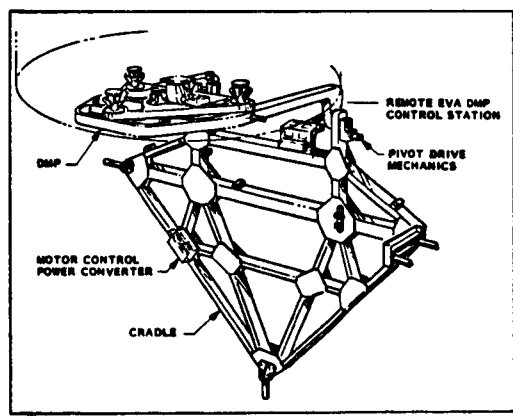
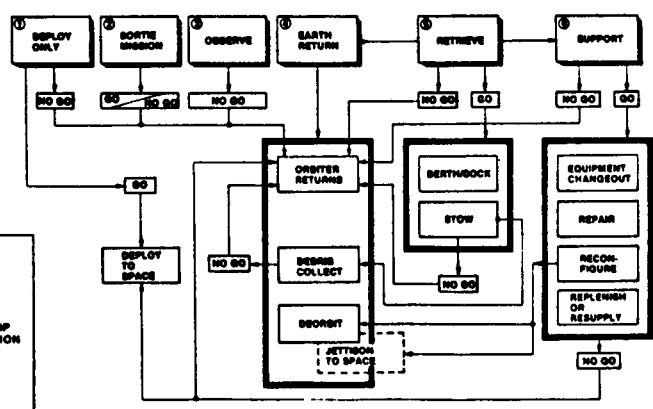

FIG. 9 DEPLOYMENT MAINTENANCE
PLATFORM (DMP)

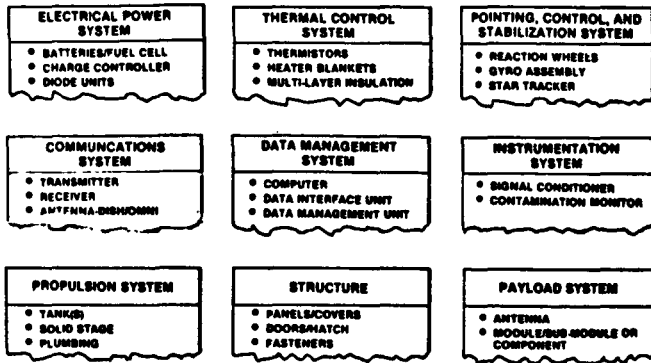

FIG. 10 SATELLITE SUBSYSTEM ELEMENTS - TYPICAL

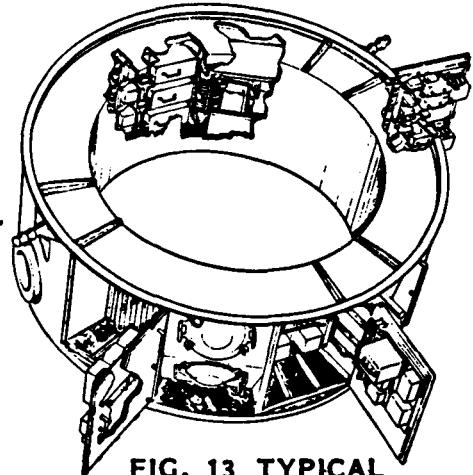

FIG. 13 TYPICAL P/L EQUIPMT SECTION

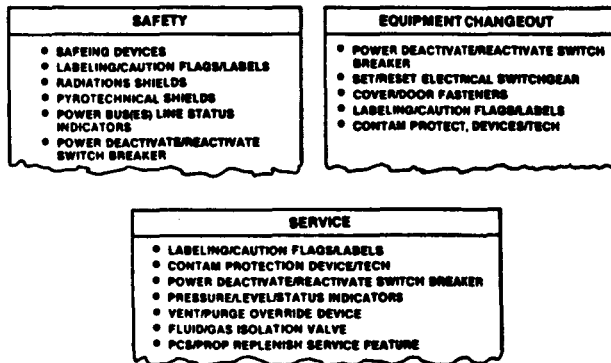

FIG. 11 CORE DESIGN FEATURES

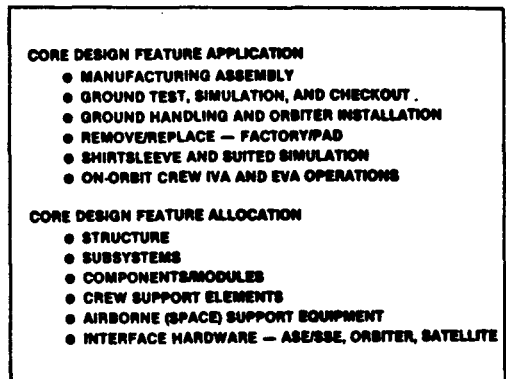

FIG. 14 CORE DESIGN FEATURES APPLICATION/ALLOCATION

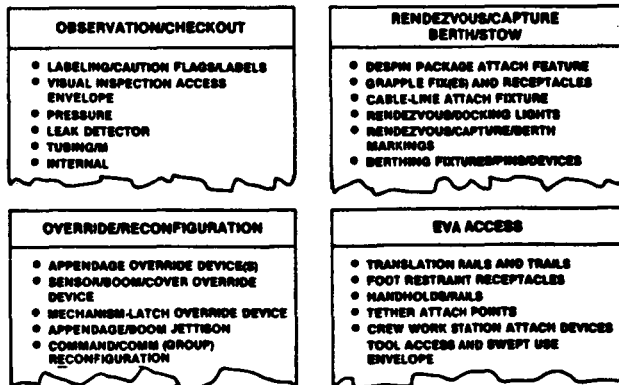

FIG. 12 CORE DESIGN FEATURES - CONTINUED

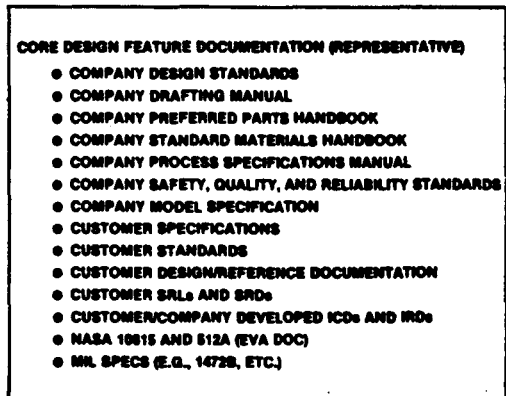

FIG. 15 CORE DESIGN FEATURE DOCUMENTATION - TYPICAL

1. NEARLY ALL TASKS CONDUCTED ABOVE WAISTLINE
2. SPECIFIC REACH ZONES ARE:
 - A. DESIGNED WITHIN A VERTICAL 30 IN. ENVELOPE
 - B. SOME TASKS REQUIRE REACH UP TO 1/2' ABOVE HORIZONTAL
 - TASKS INCLUDE CONNECTOR MATE/DEMATE AND ORU POSITIONING
 - EYE/HAND COORDINATION REQUIRED
 - CREWPERSON IS VOLUMETRICALLY BOUNDED BY STRUCTURE
 - C. INTERNAL CAVITY (E.G., EQUIP. BAY) ACCESS
 - FULL REACH DEPTH REQUIRED
 - CHEST PAK AND 'TOOL CADIE' RESTRICT REACH DEPTH
3. SUIT MOTION
 - A. CERTAIN TASKS RESULTED IN:
 - 'LEANING' SIDE TO SIDE WHILE REACHING UP TO 1/2' ABOVE HORIZONTAL
 - 'LEARNING' FULL BACKWARD WHILE CLOSING EQUIP. SECTION DOOR
 - REMOVING 1 FOOT FROM FOOT RESTRAINT AND LEANING (SIDEWAYS) TOWARD WORK SITE
 - B. BODY FATIGUE
 - SHOULDER AND UPPER ARM FATIGUE NOTED IN SUBJECTS CONDUCTING REACH (EXTENDED) HELMET LEVEL (OR HIGHER) TASKS

FIG. 16 SUIT MOBILITY/UTILIZATION RANGES - TYPICAL

FIG. 17 REMOVE/
REPLACE &
ALIGNMENT
TECHNIQUES
(PARTIAL
LISTING)

TECHNIQUE	RANGE TOLERANCE (GENERAL)	COMMENTS
1. HOLE PATTERN <ol style="list-style-type: none"> A. FASTENERS (SCREW/BOLT) 2 OR MORE B. PINS IN HOLES C. FASTENERS WITH ADJACENT PINS <ul style="list-style-type: none"> • ALONG ONE EDGE • ON OPPOSITE EDGES 	0.000 TO 0.0002 0.013 TO 0.0003	<ul style="list-style-type: none"> • IN BASE PLANCE OF SUBSTRATE • PIN TANGENT TO PART ALIGNMENT EDGE
2. GUIDES <ol style="list-style-type: none"> A. CORNER BRACKETS <ul style="list-style-type: none"> • COARSE USING PINS FOR FINAL ALIGNMENT • FINITE WITH INTEGRAL PINS B. INCLINATION (DRAFT) 	0.1 TO 0.06	<ul style="list-style-type: none"> • COARSE ALIGNMENT ONLY • PROVIDES ANGULAR HOMING ONLY • CONCENTRICITY TOLERANCE QUESTION
3. EXPANDING BOLTS - FILLS HOLE	0.0005 TO 0.0002	
4. THREADED PART <ol style="list-style-type: none"> A. TURNBUCKLE B. THREADED SCREW 	0.05 TO 0.01	<ul style="list-style-type: none"> • REQUIRES SUPPLEMENTAL MEASMT. • COARSE ALIGNMENT - VERT/ROLL
5. SLIP <ol style="list-style-type: none"> A. SLOT/KEY 	0.04 TO 0.02	<ul style="list-style-type: none"> • ACCEPTABLE FOR PLAYS MTD. ON SUBSTRATE

FIG. 18 CABLING
CONSIDERATIONS

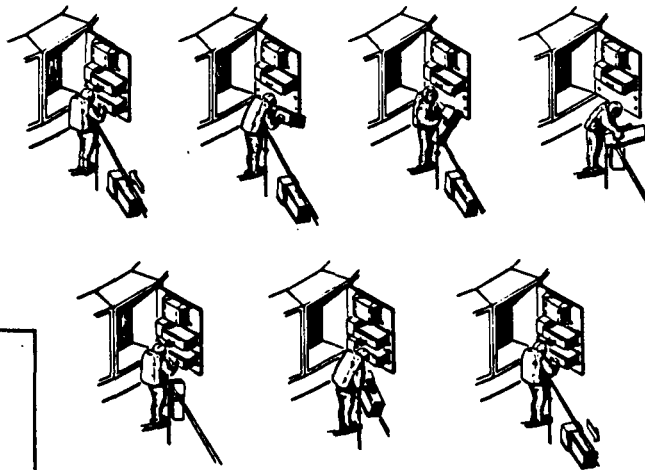
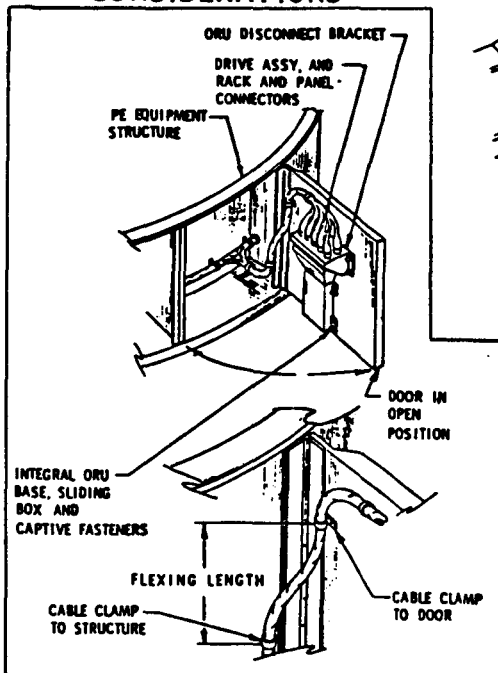

FIG. 19 ON-ORBIT EQUIPMENT XFER - EV CREW AIDED

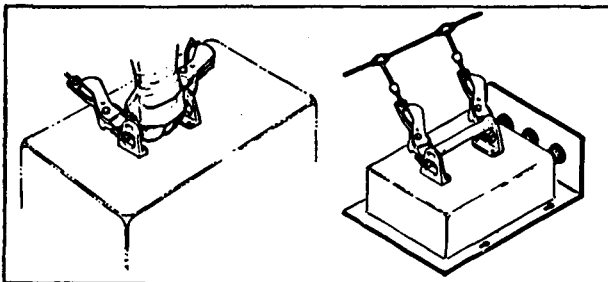

FIG. 20 EQUIPMENT TRANSFER & HANDLING

1. CAPTIVE SCREW/BOLT DOME NUTS
2. RECESSED SCREWS
3. MACHINE RADIUS CORNERS/EDGES
4. SUPPLEMENTAL CORNER/EDGE PROTECTIVE MATERIAL
5. SMOOTHED SURFACE FINISHES
6. PROTECTIVE COVER
7. ELIMINATION OF STORED ENERGY DESIGN APPROACHES
8. RECESSED EQUIPMENT
9. ELIMINATION OF EXPOSED 'ELECTRICALLY-HOT' CONNECTOR PINS
10. MINIMUM HEIGHT (THREAD EXPOSURE) CAPTIVE BOLTS
11. ELIMINATION OF BURRS THROUGH MANUFACTURING PROCESSES
12. SELECTION OF MATERIALS WHICH DON'T SPLINTER, GALL, SHREAD, ETC.

FIG. 21 TYPICAL SAFETY PROVISIONS & PROCESS

ORIGINAL PAGE IS
OF POOR QUALITY

2 N83 11191
D/16



**ELECTROPHORESIS
OPERATIONS IN
SPACE**

307

DAVID W. RICHMAN
SATELLITE SERVICES WORKSHOP
22-24 JUNE 1982

o NATURAL PRODUCTS

- NATURAL MATERIALS CONTAIN MANY POTENTIAL PRODUCTS
- PRODUCTS LIMITED BY SEPARATION CAPABILITY
- AHF FROM BLOOD PLASMA LESS THAN 1% PURE

o ELECTROPHORESIS SEPARATION

- STATIC ELECTROPHORESIS RECOGNIZED DIAGNOSTIC TECHNIQUE
- STATIC ELECTROPHORESIS LABORATORY SCALE BATCH PROCESS

o PRACTICAL PRODUCTION REQUIRES CONTINUOUS PROCESS

- CONTINUOUS FLOW ELECTROPHORESIS POTENTIAL COMMERCIAL PROCESS

308

10011 001

ORIGINAL PAGE IS
OF POOR QUALITY



ORIGINAL PAGE
BLACK AND WHITE PHOTOGRAPH

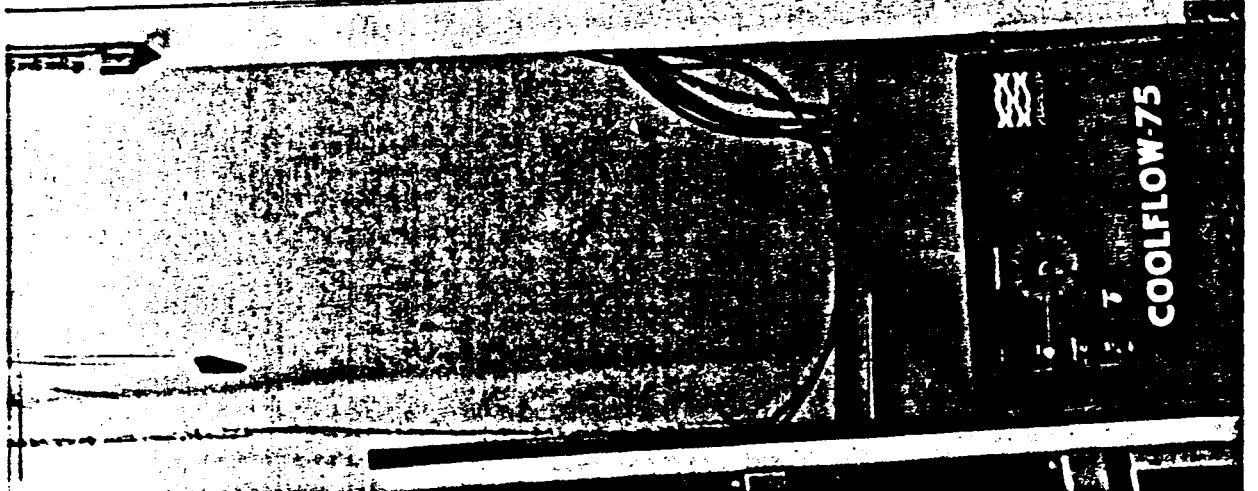
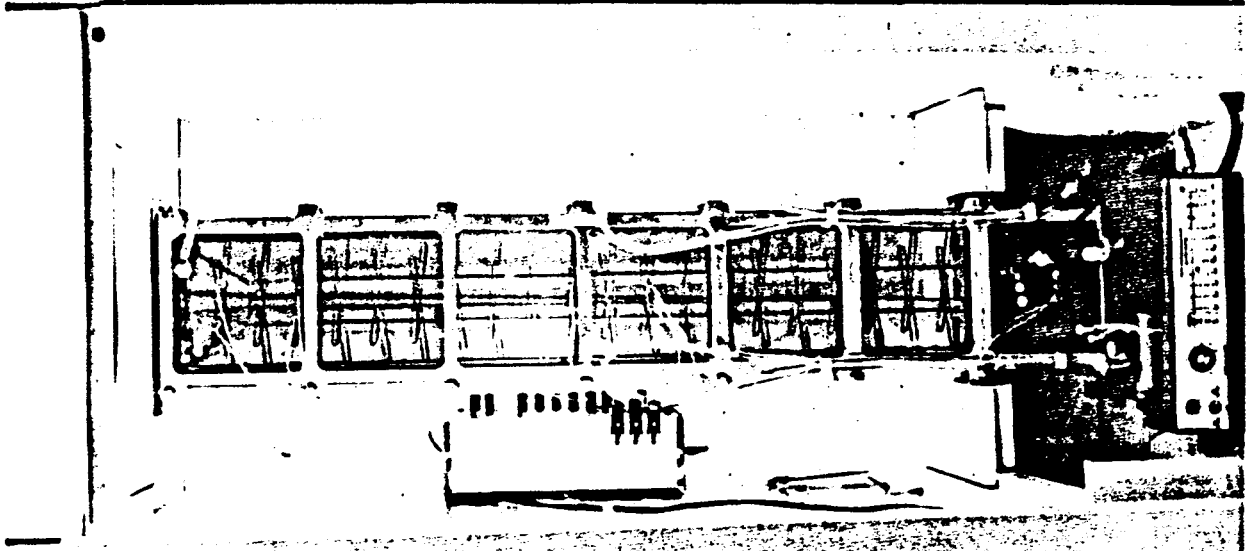
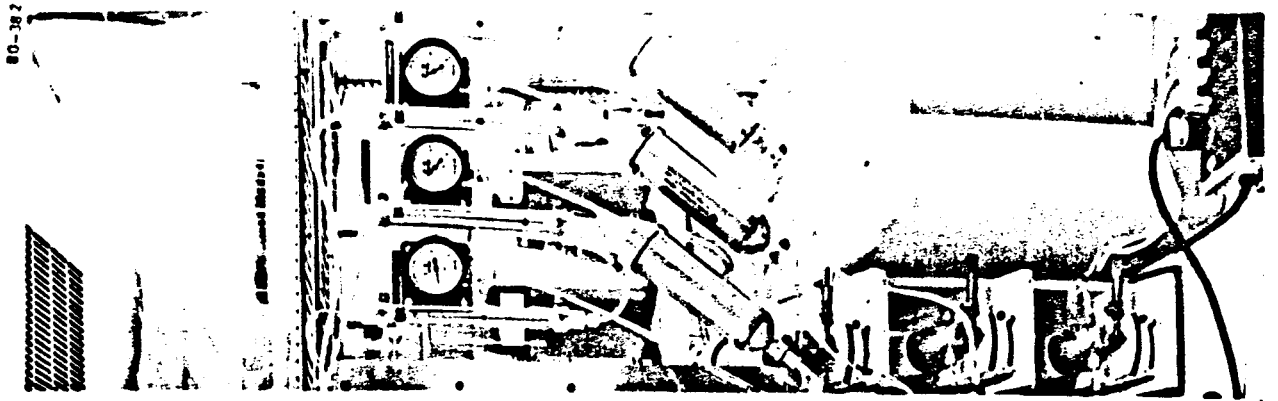

PROCESS DESCRIPTION
CONTINUOUS FLOW ELECTROPHORESIS

01-037

310

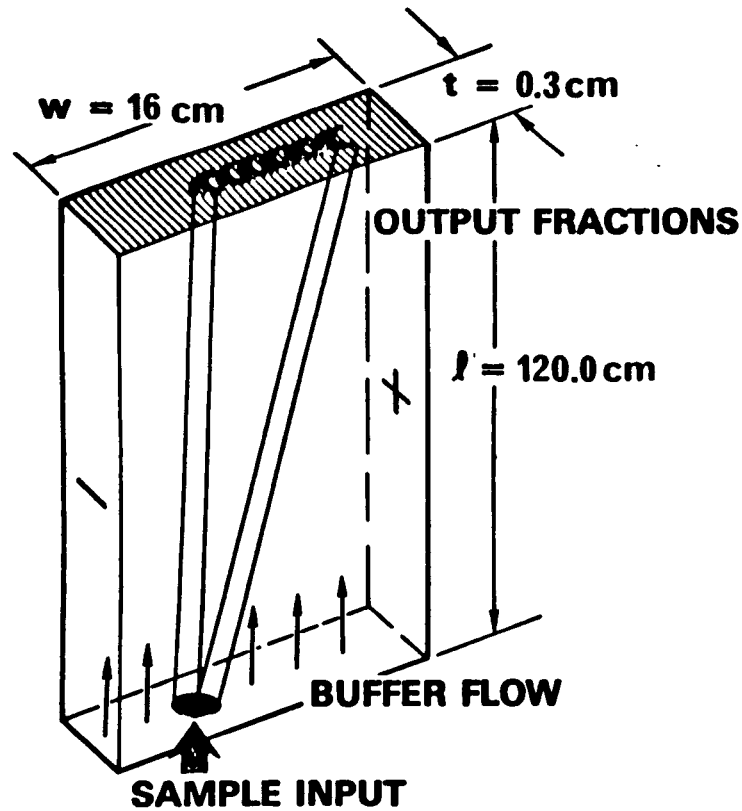

- o SAMPLE INPUT INTO LAMINAR BUFFER FLOW
- o LATERAL FORCE ON PARTICLES PROPORTIONAL TO CHARGE AND ELECTRICAL FIELD
- o LATERAL VELOCITY DEPENDENT ON VISCOUS DRAG
- o PARTICLE MOBILITY IS LATERAL VELOCITY/FIELD STRENGTH

ORIGINAL PAGE IS
OF POOR QUALITY

SAMPLE GRAVITY EFFECTS

80-269 A

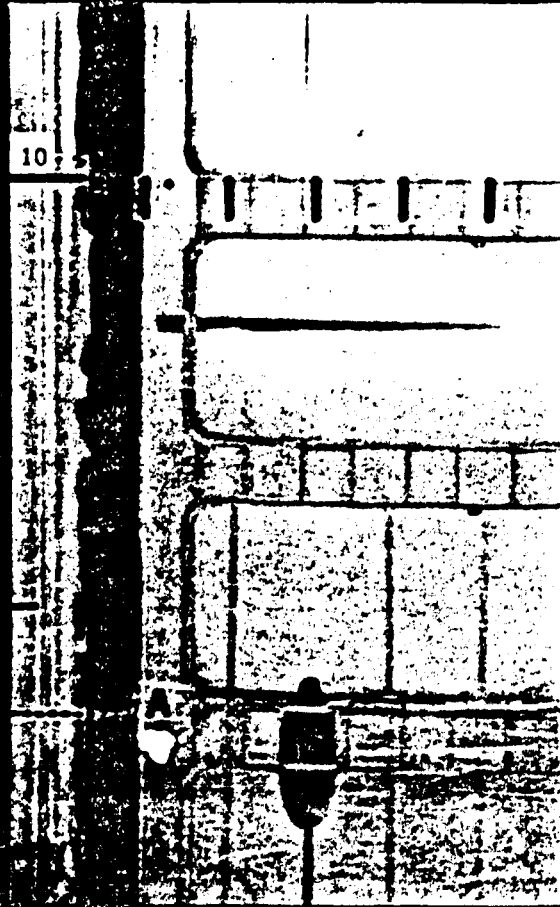

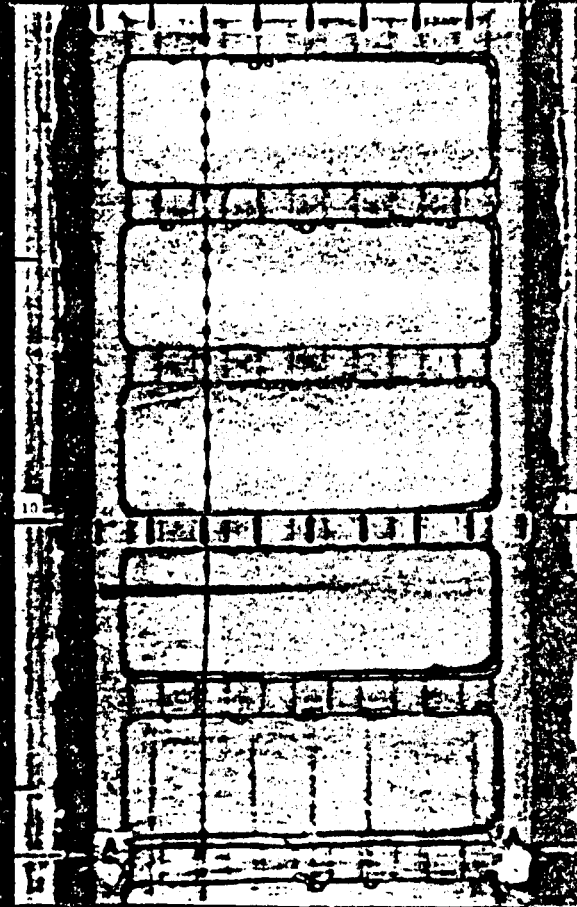

**SAMPLE
HEAVIER THAN CARRIER**



**SAMPLE
LIGHTER THAN CARRIER**

311
ORIGINAL PAGE
BLACK AND WHITE PHOTOGRAPH

**BASIS FOR INCREASED PERFORMANCE IN SPACE
DEMONSTRATION TEST SCHEDULED ON STS-4, JULY 1982**

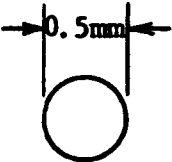
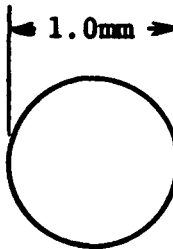
	<u>GROUND</u>	<u>SPACE</u>	<u>ADVANTAGE</u>
o CONCENTRATION	 0.25%	 25.0%	100X
o SAMPLE SIZE			4X
o SPACE ADVANTAGE			<hr style="width: 20px; margin: 0 auto;"/> 400X

312

ORIGINAL PAGE IS
OF POOR QUALITY



17-792A

MIDDECK CONTINUOUS FLOW ELECTROPHORESIS SYSTEM GALLEY LOCATION

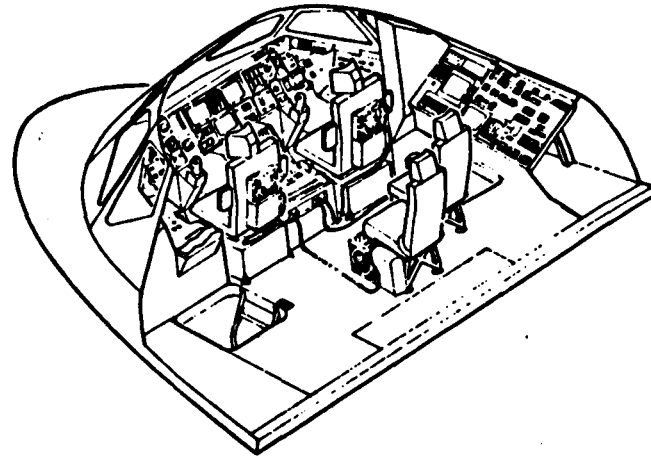
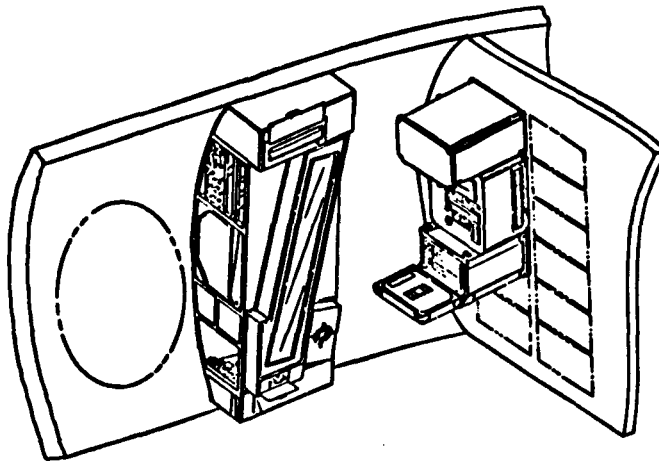

ORIGINAL PAGE IS
OF POOR QUALITY

- MIDDECK UNIT: 6 FT HIGH MODULE, 580 LBS
- SINGLE CHAMBER, SEMI-AUTOMATIC SYSTEM, SUPPORTED BY ASTRONAUT
- DEVELOP AND VERIFY PROCESS AND HANDLING PROCEDURES FOR PRODUCTS OF INTEREST
- SIX FLIGHTS PLANNED 1982 THROUGH 1984

313

7 COMMERCIAL PRODUCTION
(MDAC & ORTHO)

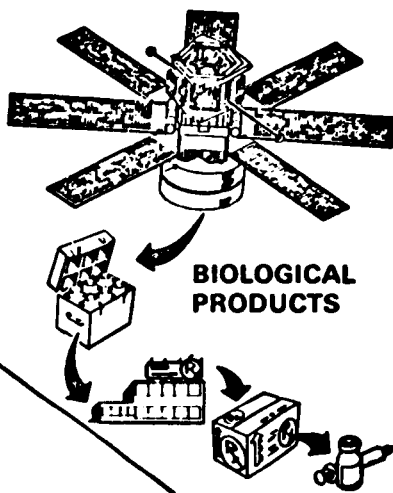

1 PROCESS DEVELOPMENT
(MDAC)

17-772A

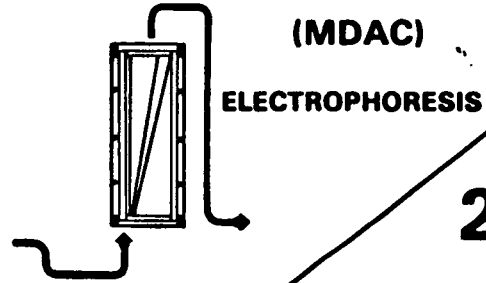

2 PRODUCT DEFINITION & MARKET ASSESSMENT
(ORTHO)

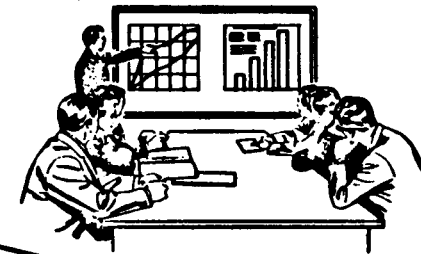

6 FDA APPROVAL
(ORTHO)



ELECTROPHORESIS OPERATIONS IN SPACE

ORIGINAL PAGE IS OF POOR QUALITY

319

SPACE VERIFICATION OF PROCESS IMPROVEMENTS

5 GOVERNMENT SUPPORT
(MDAC)

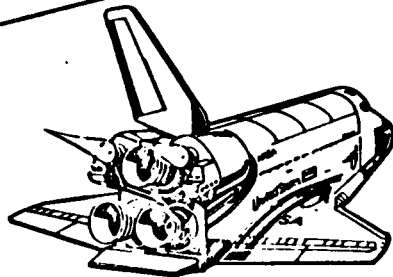

4 PRODUCT DEVELOPMENT
(ORTHO)

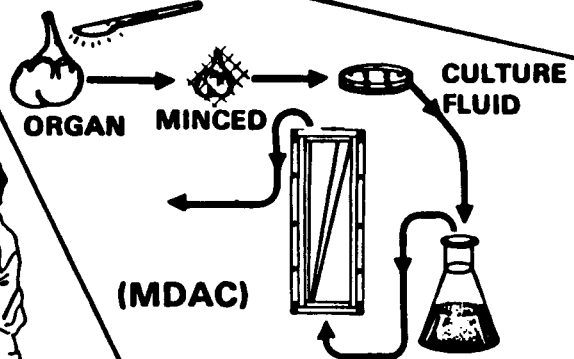

3 PRODUCT ISOLATION & PROCESSING

MCDONNELL DOUGLAS CORPORATION





PRODUCTION PROTOTYPE IN SHUTTLE PAYLOAD BAY

17-793A

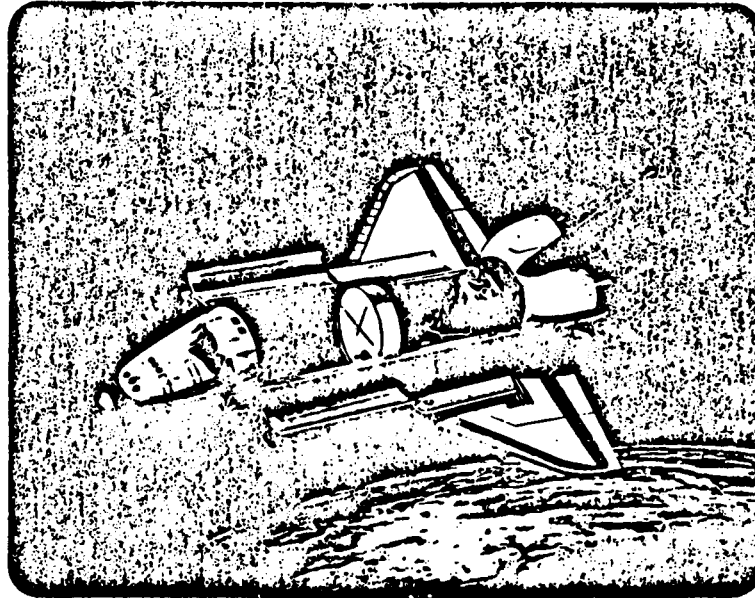

ORIGINAL PAGE IS
OF POOR QUALITY

- PRODUCTION PROTOTYPE UNIT: 4 FT X 14 FT-DIAM., 5,000 LBS
- 24 CHAMBER, AUTOMATED SYSTEM
- CHECK OUT CONTINUOUS OPERATION FOR FIVE DAYS DURING SEVEN DAY SORTIE
- PRODUCE DOSES FOR PHASE III CLINICAL TESTS
- SCHEDULED AS JEA FLIGHT 77 IN 1985

315

PRODUCTION PROTOTYPE

WITH NASA POWER SYSTEM

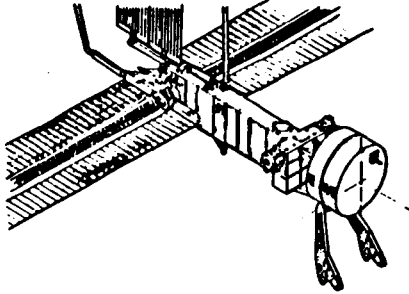

WITH MULTIMISSION MODULAR SPACECRAFT

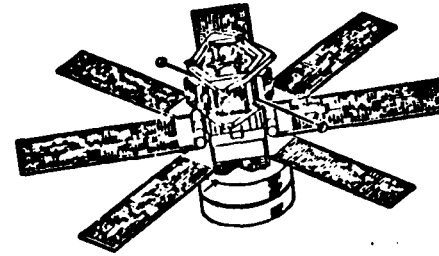

316

- PRODUCTION PROTOTYPE UNIT: 8 FT X 14 FT-DIAM., 10,000 LBS
- COMPLETE TECHNOLOGY VERIFICATION OF COMMERCIAL FEASIBILITY AS JEA FLIGHT #8 IN 1986
- PRODUCTION RATE OF 72 GMS/HR WILL BE USED TO FINISH CLINICAL TRIALS
- START COMMERCIAL OPERATION FOLLOWING FDA APPROVAL IN EARLY 1987
- WILL BE REVISITED EVERY SIX MONTHS

ORIGINAL PAGE IS
OF POOR QUALITY



17-841

EOS SHUTTLE UTILIZATION

	86	87	88	89	90	91	92	93	94	95
JEA →										
SPACECRAFT LAUNCHES AT 11K LB			2	2	2	2	2	4	3	2
FACTORY MODULE LAUNCHES AT 5K LB			2	2	2	2	2	4	3	2
RESUPPLY MODULE LAUNCHES AT 5K LB		2	5	9	13	15	19	23	26	26
FLIGHT SUPPORT SYSTEM LAUNCHES AT 3K LB		2	2	2	2	3	4	4	4	4
TOTAL MASS UP – K LB	16	63	83	103	116	139	191	190	174	
SPACECRAFT RETRIEVALS AT 6K LB						1		2	2	2
FACTORY MODULE RETRIEVALS AT 5K LB						1		2	2	2
RESUPPLY MODULE RETRIEVALS AT 5K LB		2	3	7	11	14	17	21	25	26
FLIGHT SUPPORT SYSTEM RETURN AT 3K LB		2	2	2	2	3	4	4	4	4
TOTAL MASS DOWN – K LB	16	21	41	61	90	97	119	159	164	

NOTE: ASSUMES 5 YEAR LIFE FOR SPACECRAFT AND FACTORY MODULE

ORIGINAL PAGE IS
OF POOR QUALITY

317





STEPS FOR NEW BIOLOGICAL PRODUCT DEVELOPMENT

	UNMANNED FREE FLYER MODE			MANNED SPACE STATION MODE
	MIDDECK OR SPACELAB	PAYLOAD BAY	UNMANNED FREE FLYER	
CHARACTERIZATION	✓			✓
CLINICAL TRAILS MATERIALS		✓		✓
INITIAL COMMERCIAL PRODUCTION		✓ (INTERIM)	✓	✓
EXPANDED PRODUCTION			✓	✓

318

ORIGINAL PAGE IS
OF POOR QUALITY





17-833

CONCLUSIONS

- **POTENTIAL FOR MANUFACTURING NEW AND IMPROVED PRODUCTS IN SPACE IS REAL**
- **WITHOUT LONG DURATION CAPABILITY MARKET PENETRATION FOR ANY ONE PRODUCT IS LIMITED**
- **UNMANNED FREE FLIGHT SUPPORT WILL ALLOW MARKET DEVELOPMENT FOR ONE OR MORE PRODUCTS WITHIN THE LIMITATIONS OF THE SPACE TRANSPORTATION SYSTEM**
- **MANNED LONG DURATION FACILITY CAN PROVIDE THE BASIS FOR INDUSTRY GROWTH WITH IMPROVED ECONOMICS**

ORIGINAL PAGE IS
OF POOR QUALITY

319

014 M33 111

SATELLITE SERVICES WORKSHOP

JUNE 22-24, 1982

NASA JOHNSON SPACE CENTER

SATELLITE DESIGN SESSION

SPACE PLATFORM

BY

GENE BEAM
SPACE PLATFORM PROJECT
MARSHALL SPACE FLIGHT CENTER

ORIGINAL PAGE IS
OF POOR QUALITY

320

1990-81

SPACE PLATFORM PROGRAM

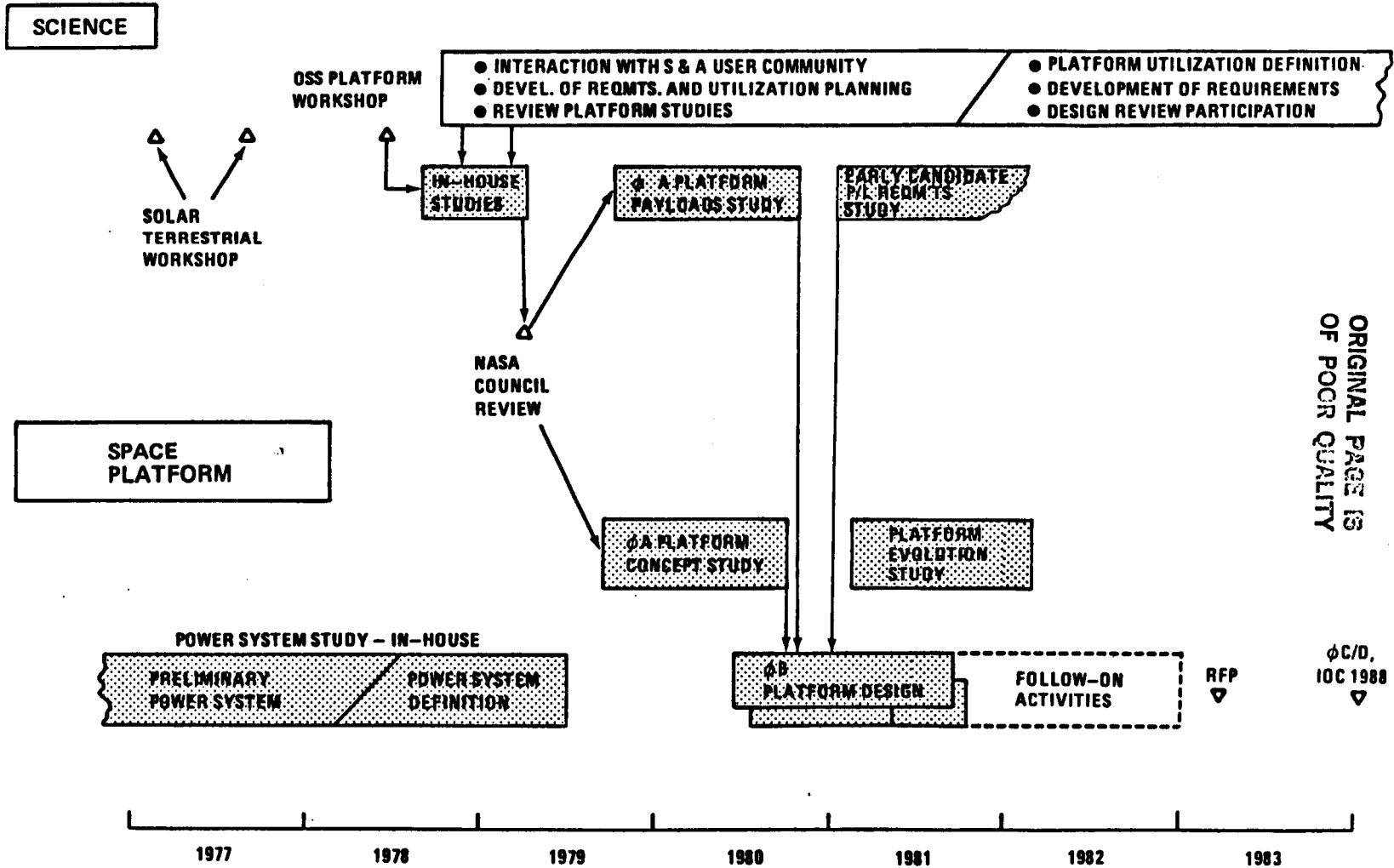

ORIGINAL PAGE IS OF POOR QUALITY

321

SPACE PLATFORM
DESIGN REQUIREMENTS

ORBIT BASED WITH MINIMUM OF FIVE-YEAR LIFE WITH MAINTENANCE

COMPATIBLE WITH STS FOR DELIVERY, MAINTENANCE AND RETRIEVAL

COMPATIBLE WITH DELIVERY AND OPERATION IN ANY STS ACCESSABLE ORBIT

PROVIDE RESOURCES FOR FREE FLYER MISSIONS

PROVIDE ELECTRICAL POWER CONTINUOUSLY TO THE USER AT 28VDC OR 120 VDC

PROVIDE HEAT REJECTION FOR PAYLOADS

PROVIDE ORBIT ALTITUDE MAINTENANCE WITHOUT ORBITER REVISIT FOR A
MINIMUM OF ONE YEAR

PROVIDE HIGH DATA RATE COMMUNICATIONS TO THE GROUND VIA TDRSS

MINIMIZE COST AND RISK THROUGH USE OF EXISTING DESIGNS

322

SPACE PLATFORM SUBSYSTEM DESIGN CHARACTERISTICS

ELECTRICAL POWER (APPROXIMATELY 12 kW)

- O DUAL WING FLEXIBLE FLATFOLD SOLAR ARRAY (APPROX. 31 kW CAPACITY)
- O MODULAR DESIGN WITH MULTIPLE POWER PROCESSING GROUPS
 - 50 AH NiCd BATTERIES
 - P³ CHARGERS AND REGULATORS
- O UTILIZATION OF EXISTING HARDWARE/DESIGNS (SEPS, MMS, ETC.)

THERMAL CONTROL (APPROXIMATELY 12 kW)

- O PUMPED FLUID SYSTEM
 - DEPLOYABLE FLUID RADIATOR
 - COLD PLATES FOR SUBSYSTEM COOLING
 - DUAL LOOP SYSTEM
 - HEAT EXCHANGER PAYLOAD COOLING INTERFACE
- O UTILIZATION OF EXISTING HARDWARE/DESIGNS (SHUTTLE, SPACELAB)

ORIGINAL PAGE IS
OF POOR QUALITY

323

SPACE PLATFORM SUBSYSTEM DESIGN CHARACTERISTICS (CONT'D)

ATTITUDE CONTROL (3 AXIS POINTING & STAB. WITH SUB ARC MIN. ACCURACY)

- CONTROL MOMENT GYROS (CMG) AND RATE GYROS FOR POINTING AND STABILIZATION CONTROL
- MAGNETIC TORQUERS FOR MOMENTUM MANAGEMENT
- EARTH, SUN AND STAR SENSORS FOR ATTITUDE DETERMINATION.
- UTILIZATION OF EXISTING HARDWARE/DESIGNS (SKYLAB, SPACE TELESCOPE, ETC.)

COMMUNICATIONS (50 KBPS - 200 + MBPS)

- REDUNDANT LOW DATA RATE S-BAND AND HIGH DATA RATE KU-BAND THRU TDRSS
- UTILIZATION OF EXISTING HARDWARE/DESIGNS (LANDSAT, FLT SAT COM, MMS, ETC.)

DATA HANDLING (RATES COMPATIBLE WITH COMM. SUBSYSTEM)

- REDUNDANT CENTRAL COMPUTER AND DATA BUS
- LOW DATA RATE RECORDERS
- HIGH DATA RATE MULTIPLEXERS AND RECORDERS
- UTILIZATION OF EXISTING HARDWARE/DESIGNS (SHUTTLE, SPACELAB, MMS, ETC.)

SPACE PLATFORM SUBSYSTEM DESIGN CHARACTERISTICS (CONT'D)

PROPULSION

- BLOWDOWN HYDRAZINE SYSTEM
- REDUNDANT THRUSTERS FOR REBOOST AND ATTITUDE CONTROL BACKUP
- UTILIZATION OF EXISTING HARDWARE/DESIGNS (TDRSS, HEAO, IUS, ETC.)

STRUCTURE

- STANDARD AEROSPACE CONSTRUCTION USING ALUMINUM FRAMES AND SHEAR PANELS

SPACE PLATFORM EVOLUTION SCENARIOS

ORIGINAL PAGE
BLACK AND WHITE PHOTOGRAPH

326

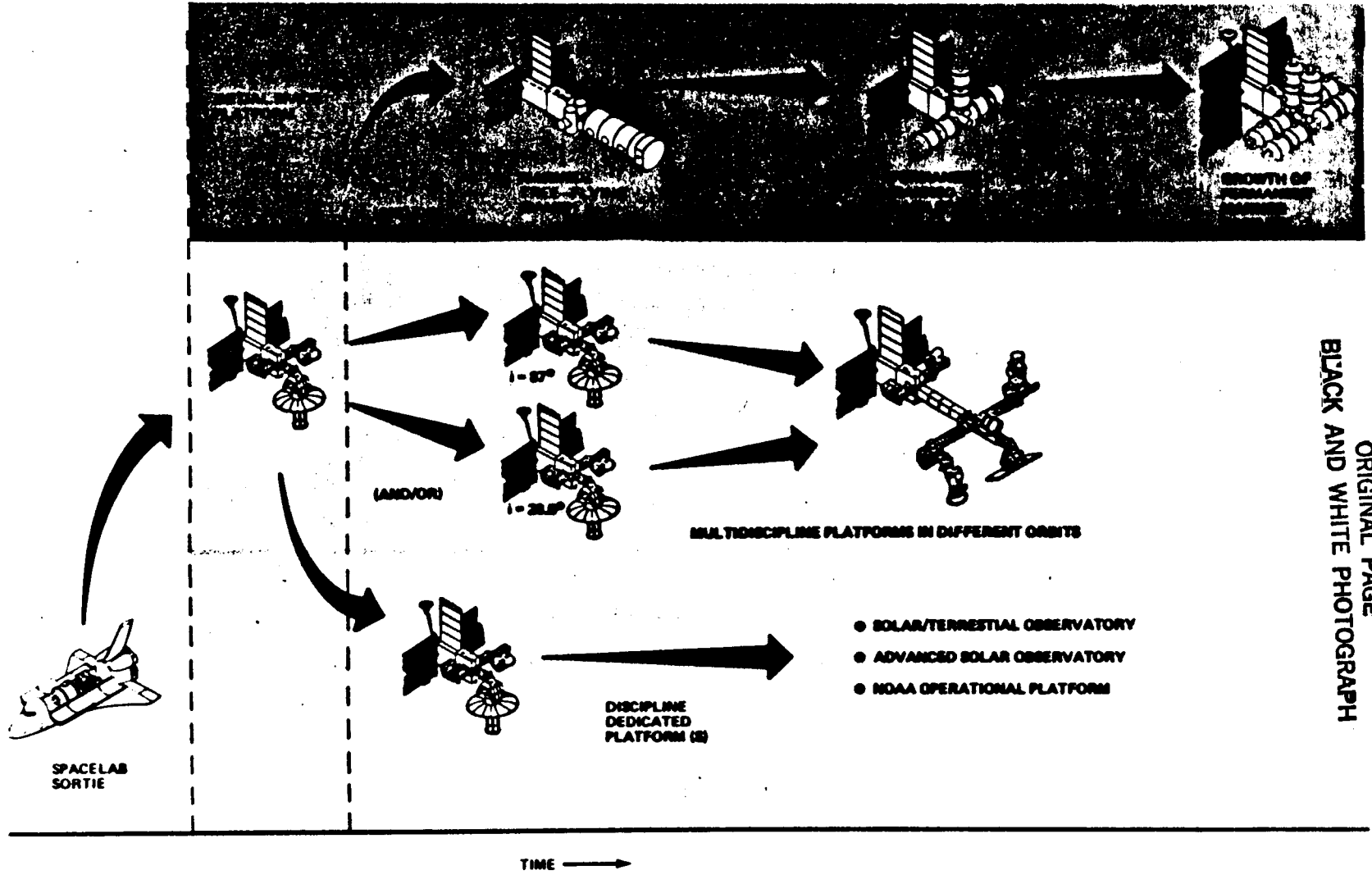

25kW POWER SYSTEM RENDEZVOUS & BERTHING

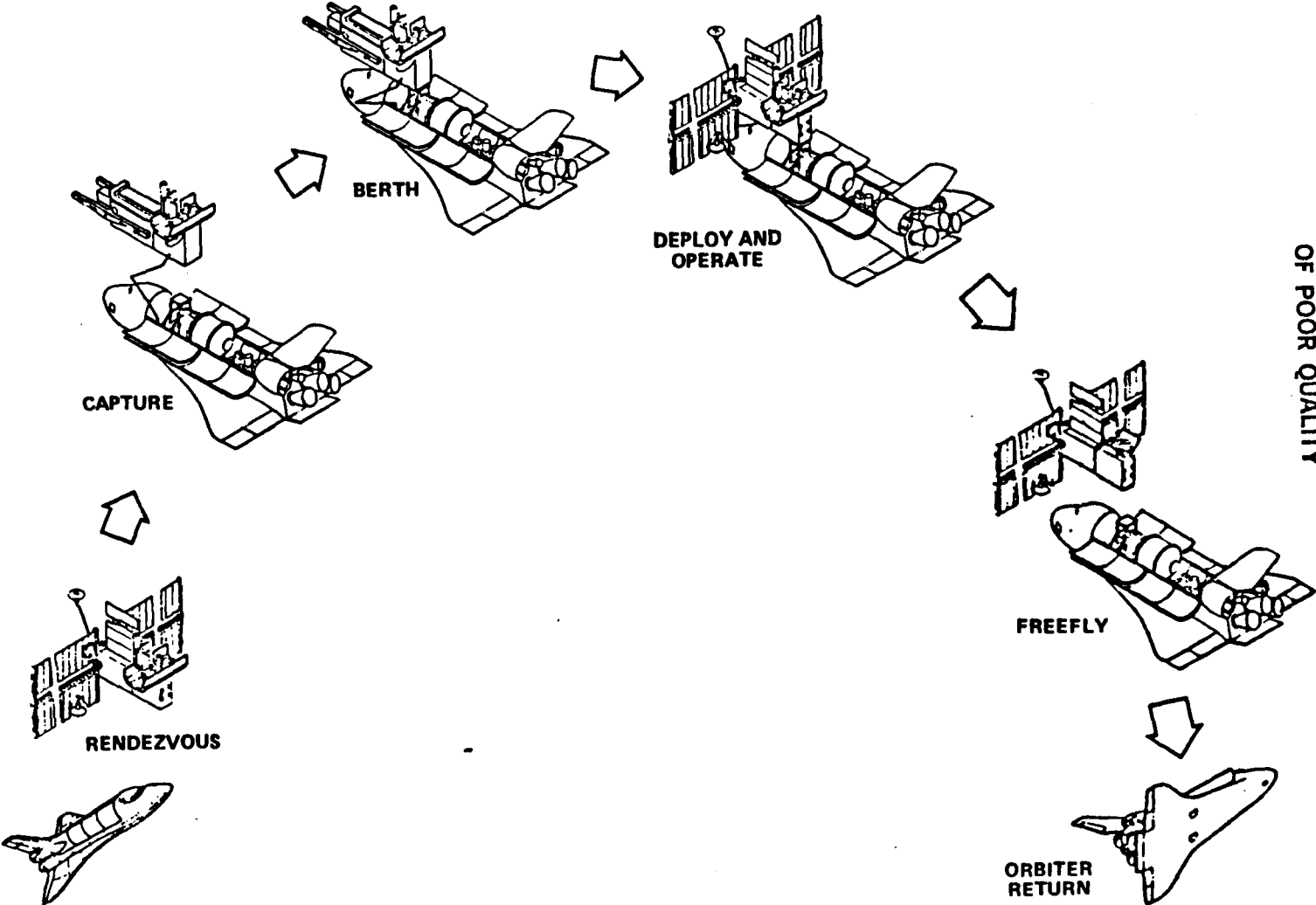

ORIGINAL PAGE IS
OF POOR QUALITY

327

SPACE PLATFORM
ON-ORBIT SERVICING AND MAINTENANCE

- o AN ORBITAL REPLACEABLE UNIT (ORU) IS THE HARDWARE TO BE REPLACED AS A UNIT DURING ON-ORBIT MAINTENANCE

- o FOR ON-ORBIT SERVICING AND MAINTENANCE THE SPACE PLATFORM MUST:
 - MEET THE STS/ORBITER RETRIEVAL REQUIREMENTS (NHB 1700.,7A)
 - BE COMPATIBLE WITH THE RMS FOR CAPTURE, BERTHING AND MAINTENANCE OPERATIONS
 - BE IN A BERTHED MODE FOR CREW MAINTENANCE OPERATIONS

328

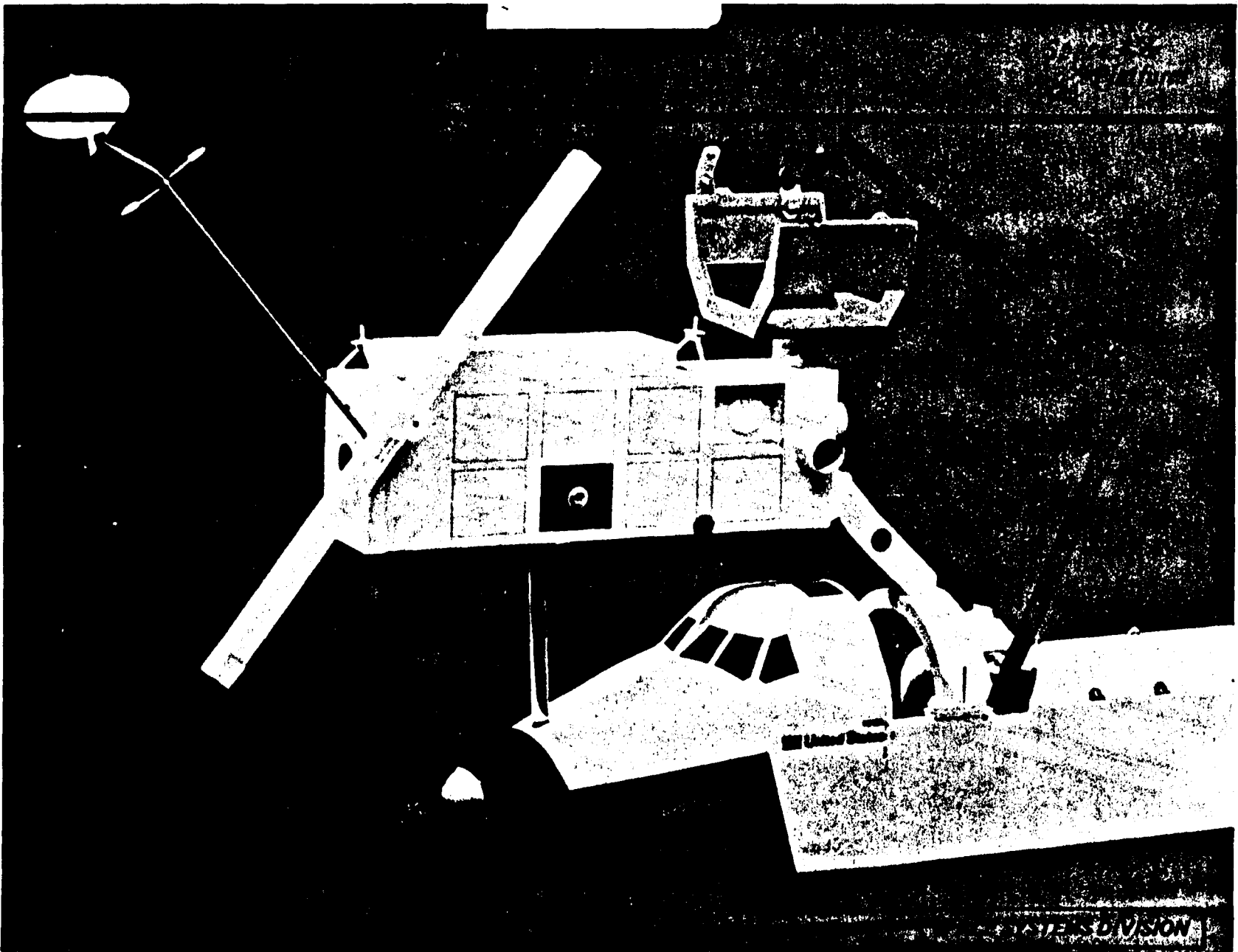

329

ORIGINAL PAGE
BLACK AND WHITE PHOTOGRAPH

PAVERS DIVISION

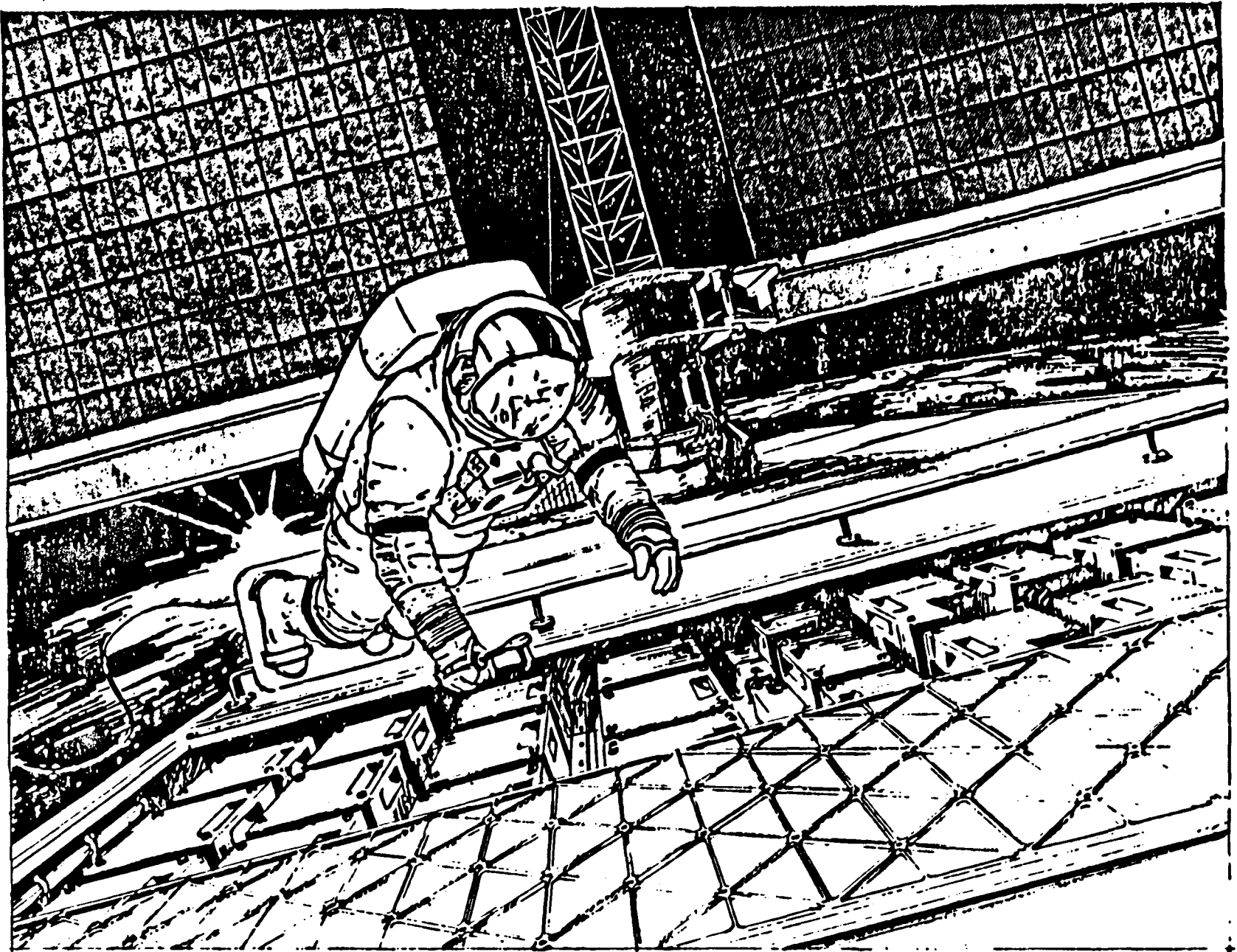

330

ORIGINAL PAGE
BLACK AND WHITE PHOTOGRAPH

SPACE PLATFORM
ON-ORBIT MAINTENANCE

SYSTEMS REQUIREMENTS

- o DESIGN ALL ACTIVE SYSTEMS FOR ON-ORBIT MAINTENANCE
- o ON-ORBIT MAINTENANCE SHALL NOT COMPROMISE THE INTEGRITY OF THE FLIGHT SYSTEM
- o THE DESIGN FOR MAINTENANCE SHALL BE VERIFIED
- o ORU'S SHALL BE EASILY ACCESSIBLE TO THE EVA CREWMEN IN THE BERTHED MODE WITHOUT
REMOVAL OF OTHER ORU'S

331

ORIGINAL PAGE IS
OF POOR QUALITY

SPACE PLATFORM
ON-ORBIT MAINTENANCE

DESIGN REQUIREMENTS

- SYSTEM DESIGNED FOR EVA ACCESS
 - HAND RAILS - TRANSLATION AIDS
 - HAND HOLDS - FOOT RESTRAINTS
 - TEATHER ATTACHMENTS - CREW AND EQUIPMENT
 - CREW/SUIT SAFETY
 - SHARP EDGES
 - ELECRIC SHOCK
 - FLUIDS/GAS EXPOSURE

- ORU'S DESIGNED FOR EVA REPLACEMENT
 - CREW/SUIT SAFETY
 - CREW HANDLING AIDS
 - EVA SUIT/GLOVE COMPATIBILITY - ACCESS AND TASK
 - ALIGNMENT GUIDES
 - QUICK DISCONNECTS
 - COMPATIBLE WITH STANDARD EVA TOOL KIT
 - MEET MAN/SYSTEMS REQUIREMENTS - MSFC - STD - 512A AND JSC 10615

- SYSTEM DESIGNED FOR ON-ORBIT MAINTENANCE OPERATIONS
 - FAULT DETECTION TO THE ORU LEVEL WITH FLIGHT AND GROUND SYSTEMS
 - SYSTEM CONFIGURATION/STATUS TO A SAFE AND OPERATIONAL CONDITION
 - SYSTEM SAFE FOR REMOVAL/REPLACEMENT
 - MAINTAIN REQUIRED OPERATIONAL LEVEL

332

ORIGINAL PAGE IS
OF POOR QUALITY

SPACE PLATFORM
ON-ORBIT MAINTENANCE

CONSIDERATIONS FOR SELECTION OF ORU LEVEL

- o ORU'S MAY BE AT VARIOUS LEVELS FOR A SINGLE SPACECRAFT
 - COMPONENT
 - EQUIPMENT GROUP
 - ASSEMBLY OR FUNCTIONAL GROUP
- o SYSTEM DESIGN IMPACT
 - FAULT DETECTION LEVEL REQUIRED
 - SYSTEM CONTROL TO PROVIDE MAINTENANCE STATUS
- o DESIGN COMPLEXITY AND COST TO MEET ORU CAPABILITY
- o THE REQUIREMENTS FOR AND COST OF LOGISTICS SUPPORT AND SPARES

333

SPACE PLATFORM
ON-ORBIT MAINTENANCE

OBSERVATIONS FOR NEW PROJECTS

- ON-ORBIT MAINTENANCE MUST BE PROJECT LEVEL REQUIREMENT
 - PROJECT REQUIREMENT
 - CONTRACT REQUIREMENT
 - PROJECT CONTROLLED

- ON-ORBIT MAINTENANCE MUST BE IMPLEMENTED EARLY
 - CONCEPT DEFINITION MUST IMPLEMENT
 - BY ALL DESIGN ORGANIZATIONS STARTING WITH PRELIMINARY DESIGN

- MUST BE A SYSTEMS APPROACH
 - ACCESS
 - FAULT DETECTION
 - SYSTEM CONFIGURATION FOR REPLACEMENT
 - LOGISTICS

334

ORIGINAL PAGE IS
OF POOR QUALITY

**PAYLOAD INSTALLATION AND DEPLOYMENT AID
FOR SPACE SHUTTLE ORBITER SPACECRAFT REMOTE MANIPULATOR SYSTEM**

Thomas O. Ross

**Lyndon B. Johnson Space Center
Houston, Texas**

ABSTRACT

Early developmental testing of the Remote Manipulator System (RMS) revealed that on-orbit handling of various payloads on the Space Shuttle Orbiter Spacecraft may prove to be beyond the capability of the system without the assistance of a handling aid.

An aid concept known as the PIDA (Payload Installation and Deployment Aid) is presented as a way to assist the RMS by relaxing the accuracy required during payload handling in the payload bay. The aid concept was designed and developed to move payloads through a prescribed path between the confined quarters of the payload bay and a position outside the critical maneuvering area of the Orbiter.

An androgynous docking mechanism is used at the payload/PIDA interfaces for normal docking functions that also serves as the structural connection between the payload and the Orbiter, that is capable of being loosened to prevent transfer of loads between a stowed payload and the PIDA structure. A gearmotor driven drum/cable system is used in the docking mechanism in a unique manner to center the attenuator assembly, align the ring and guide assembly (docking interface) in roll, pitch, and yaw, and rigidize the mechanism at a nominal position. A description of the design requirements and the modes of operation of the various functions of the deployment and the docking mechanisms are covered.

INTRODUCTION

The conceptual design study and operational simulations of the Remote Manipulator System (RMS) in the JSC Manipulator Development Facility (MDF) identified a need for an aid in the handling of large payloads into and out of the cargo bay by the manipulator.

In response to this need, a payload handling aid concept was designed and developed for use with the RMS.

The initial design concept was turned into prototype hardware for test and evaluation and this developed into a second set of prototype hardware that helped to define the concept as it is presently known and described in the following sections.

The initial concept of the deployment mechanism contained one rotating arm assembly to be used in conjunction with the RMS/operator for payload handling.

After building and testing prototype hardware of the Aid with a prototype of the manipulator, it was discovered that the RMS operator was unable to follow the arc path required to keep the payload aligned. It was concluded that the handling aid should be capable of moving the payload between the stowed and deployed positions automatically without the assistance of the RMS in the control loop but that the RMS would be in complete control of the payload during docking or undocking with the payload/orbiter interfaces on the handling aid mechanism.

The resulting aid concept, depicted in Figure 1, known as the PIDA (Payload Installation and Deployment Aid), is presently being fabricated as flight-like hardware for engineering development test and evaluation in the JSC Manipulator Development Facility. This effort is intended to develop the aid concept to a state of readiness for a minimum lead time for flight hardware and at the same time developing the electromechanical actuator and the docking mechanism for potential use in other applications.

REQUIREMENTS

The basic requirements that were imposed on the Payload Installation and Deployment Aid concept are:

- o Provide line of sight docking points outside of critical maneuvering area.
- o Utilize single point capture steps as opposed to multi-points requiring simultaneous capture.
- o Use mechanism to move the payload from deployed to stowed position without exceeding a 75mm (3.0 inch) payload clearance envelope.
- o Accommodate payloads ranging up to 4.57 meters (15 ft) dia by 18.3 meters (60 ft) long and 289 kN (65,000 lbs) weight.
- o Accommodate payload contact velocities up to 30mm/sec (.10 ft/sec) and .011 rad/sec with a lateral mismatch of 150mm (6.0 inches) maximum and angular mismatches of $\pm 15^\circ$ in pitch and yaw and $\pm 10^\circ$ in roll.
- o Design to stow in a confined space under the closed doors with a large payload in the cargo bay.
- o Utilize existing longeron bridge fitting attachments for structural connection.

PIDA ASSY DESCRIPTION

The PIDA assembly shown in Figure 6 is made up of a deploy/stow mechanism, an interface mechanism, an electromechanical rotary actuator with its respective electronic controls, and a base, with a jettison interface, that connects the assembly to the Orbiter longeron bridge fitting on installation.

The operation of the assembly between the stowed and deployed positions, shown in Figure 7, is done remotely from the RMS operator's station. The operator can select the degree of deployment desired and monitor its position from a display of the optical encoder data that is used to control the drive motors and keep them synchronized to within one-tenth of a degree. Preprogramming for a specific payload provides the control of the master drive to accelerate and then decelerate the payload to stop at the desired point without overrun or excessive structural loads on the PIDA structure or the Orbiter longeron attach points. The accuracy provided by the control system offers precise pointing of payloads and opens the possibility of limited tracking using the PIDA drive system with added tracking sensors.

DEPLOY/STOW MECHANISM

The basic purpose of the deploy/stow mechanism is to control the movement of the payload positively and accurately between the stowed and deployed positions and to locate the payload in a deploy position that is away from the Orbiter, outside of the critical maneuvering area but with the docking interfaces in the line of sight of the RMS operator. Design guidelines required that the movement between the stowed and deployed positions be provided without exceeding a 75mm (3.0 inches) payload clearance envelope and that the deployed position be located for a minimum clearance of 50cm (19.5 inches) between the payload and the Orbiter. The configuration had to permit the mechanism to be stowed in a confined space under the closed door and radiator with a large payload 4.57 meters (15 feet) diameter by 18.3 meters (60 feet) long in the payload bay.

The original version of the present deployment mechanism employed a two-stage actuation as shown in Figure 3. The first stage used a pivot point close to the tangency of the payload on one side for an upward z-z axis path of withdrawal and the second stage utilized a pivot point at the docking mechanism interface to swing the payload outboard to a noncritical maneuvering area for payload/PIDA docking. The two stages were driven from a single actuator on each arm assembly that required a clutching operation for the change over from one stage to the other.

Due to the complexity of the two-stage actuation, a single actuator drive mechanism, shown in Figure 4, with a continuous integrated motion was conceived to replace it while at the same time closely approximating the motion desired. A trial and error graphical approach was used to define the mechanism necessary to provide the desired motion. At the onset, the graphical layout was intended to identify the constraints for an analytical approach but it was concluded that the graphical approach would be quicker to complete the geometry definition.

The four bar mechanism shown in Figure 5 has a tubular drive arm member that is connected at one end to the base and the other end to the crank arm on the interface mechanism. A drag link that serves as a tension/compression tie between the base and the end of the crank arm provides the linkage to turn the crank arm as the main arm is driven from one position to another by an Electro-mechanical Rotary Actuator. As the main arm rotates through an angle of 56° , the crank arm rotates the interface mechanism $102^\circ 37'$ for an angular displacement ratio of 1.83:1. The total rotation of the payload axis relative to the Orbiter axis is the sum of these two angles or $158^\circ 37'$.

Note in Figure 4 how the initial part of the C.G. path approximates an upward (z-z axis) linear withdrawal by a low amplitude sinusoidal movement. The movement of the longeron trunnion next to the mechanism, shown in detail "Z", provided an upward and outboard movement that although unplanned was found to be acceptable in the mating envelope of the retention fitting halves.

INTERFACE MECHANISM

The payload/PIDA interface mechanism, shown in Figures 8 and 9, includes a docking mechanism for the RMS operator to connect or disconnect the payload from the deploy/stow mechanism and a structural connection to positively hold the payload during deploy or stow actuation to aid accurate positioning of the payload in the payload bay. After the payload has been placed in the fully stowed position, the structural connection through the PIDA is loosened to provide compliance in order to force the retention fittings to be the primary load paths. The mechanism provides the basic functional modes of docking, such as, compliance, capture, energy absorption, alignment and rigidization in addition to the stowed position compliance.

. Docking Compliance

The purpose of docking compliance is to allow the two mating sides of the interface to align in order that the capture latches can operate. The mechanism on the active side of the docking interface moves as required for alignment except for lateral compliance.

The lateral compliance and attenuation is not an active part of the mechanism, but is accommodated by the dynamics of the Orbiter and payload interreactions.

The axial compliance and attenuation, both compression and extension, is furnished by a hydraulic-type attenuator that has internal spring action to return it to a nominal position that is preloaded in both directions.

The roll alignment movement is permitted by the outer part of the ring and guide assembly being free to rotate relative to the center part of the assembly. The two parts are connected through two ball bearings and are spring loaded to a nominal position by the spring preload.

The pitch and yaw compliance is provided by a "U" joint located between the center of the interface ring and the attenuator assembly.

Docking Capture

The guides on the interface ring are sized for 152mm (6.0 inches) lateral misalignment (which includes the mismatch due to $\pm 15^\circ$ pitch or yaw) in combination with a roll misalignment of $\pm 10^\circ$. The guide configuration provides lateral forces to act on the Orbiter and payload for dynamic lateral compliance to permit the capture latches to engage. The capture latches are designed such that, if insufficient latches are engaged to react capture loads, none will remain engaged. Any two latches are able to react the capture loads. If only

one latch is engaged, the force vectors act in a direction upon the latch during a separation motion such that the toggle linkage of the latch will collapse to allow the two docking surfaces to separate freely. The capture latches serve a dual role in as much as they are also used as the structural latches to secure the payload to the Orbiter after the docking phase is complete.

Energy Absorption

A payload with kinetic energy relative to the Orbiter, contacts the docking interface causing the attenuator assembly to be compressed. During this compression stroke, hydraulic fluid is metered from the head end to the rod end of the attenuator. Part of the kinetic energy is dissipated by the fluid metering and the remainder is stored in the attenuator spring as potential energy. At the end of the compression stroke, the spring forces the attenuator to extend toward the nominal position transferring the potential energy back into the payload as kinetic energy. During this extension stroke, the fluid is metered from the rod end to the head end of the attenuator, further dissipating energy. As the attenuator reaches its nominal position the attenuator spring reverses its force direction to once again store the undissipated energy as potential energy. The residual energy is dissipated by the subsequent extension and compression strokes with rapidly decaying amplitude so that ultimately all motion is arrested and the interface returned to the nominal position.

Alignment and Rigidization

Roll, pitch and yaw alignment across the interface is provided by the ring and guide assembly on each side mating with the one on the other side of the interface. This allows a payload to be positioned accurately even in installations employing only one PIDA assembly.

Realignment of the ring and guide assembly on the active half of the docking interface, with its mechanism is accomplished by the use of three pusher rods and a cable drive system. The action of taking up cable slack in three cable assemblies forces the three pusher rods to extend to a nominal position and retracts the active ring and guide assembly in contact with the ends of these pusher rods for alignment and rigidization. The ends of these rods are hemispherical and contact a conical seat on the surface of the other part of the interface ring to provide the camming action necessary to realign the ring in roll, pitch, and yaw. Actuation is provided by an electromechanical actuator driving a cable drum through a gear train. The electric motor has a brake that is energized to hold the mechanism rigid after the drive motor has stalled out, to preload the cable assemblies, and is then turned off.

The holding requirement of the mechanism is based on an interface moment of 678 N-m (500 lb-ft) as determined from dynamic analysis of the payload/Orbiter system using math modeling.

The inside of the cable drum has two cam surfaces located symmetrically opposite each other to actuate two cam followers, one on each side of the attenuator, to force it to a centered position or free it to allow the attenuator to pivot during the stowed position compliance movement. In the upper

half of Figure 9 the attenuator is held centered and the lower half of the view shows the cam surface away from the cam follower to allow the attenuator to pivot.

STOWED POSITION COMPLIANCE

The payload retention system requires that the payload be permitted to have a three axis movement to accommodate thermal deflections. This necessitated that the PIDA have the same freedom if it is not to act as a primary structural connection for a stowed payload. The x-x axis freedom is provided by floating one of the passive docking interfaces on the payload with it being spring loaded to a center or nominal contact position. The y-y axis and z-z axis movement is provided by retracting the three pusher rods to allow the attenuator to stroke and backing off the two cam followers to permit the attenuator to pivot in the y-z plane.

ELECTROMECHANICAL ROTARY ACTUATOR

The electromechanical rotary actuator designed and fabricated to drive the deploy/stow mechanism was sized to provide a maximum torque of 1356 N-m (1000 lb-ft) at a rate of one degree per second. This is accomplished through the use of a gear box with two high ratio planetary drives, a 24/1 input stage and a 32/1 output stage, resulting in an overall ratio of 768/1 for the actuator in conjunction with a 5.4 N-m (4.0 lb-ft) 28 volt direct current electric motor.

CONCLUSIONS

The Orbiter baseline configuration does not include the PIDA handling aid concept. Further test and evaluation both on-earth and on-orbit will be required to resolve the need for a handling aid to assist the Remote Manipulator System (RMS) on the Orbiter.

Tests results on prototype hardware indicate that the PIDA payload handling aid concept can be of significant help to the RMS operator by relaxing the control requirements and promises to enhance payload bay packaging density and payload maintenance access.

Initiation of the development of the PIDA concept has been effective in reducing the long-lead time required for flight hardware. A continuation of this development will provide hardware that with minimal changes could be flown as an on-orbit experiment with a RMS and a test payload to evaluate the overall payload handling capability of the Orbiter.

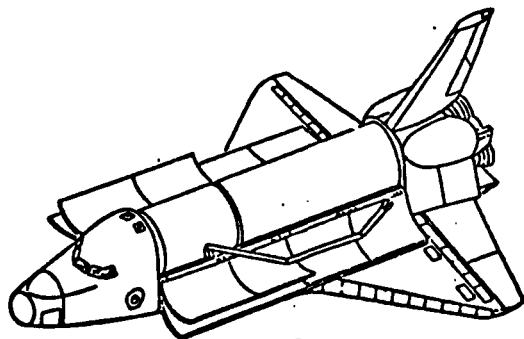

1

RETENTION FITTINGS UNLOCKED TO
RELEASE PAYLOAD & PAYLOAD/PIDA
INTERFACES RIGIDIZED (MANIPULATOR
MOVED CLEAR OF PAYLOAD)

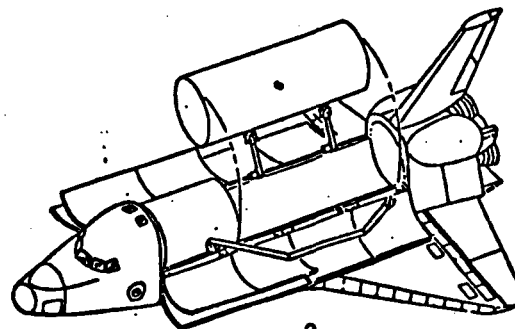

2

SYNCHRONIZED DRIVE ARMS ROLL
PAYLOAD OUT OF BAY TO FULLY
DEPLOYED POSITION

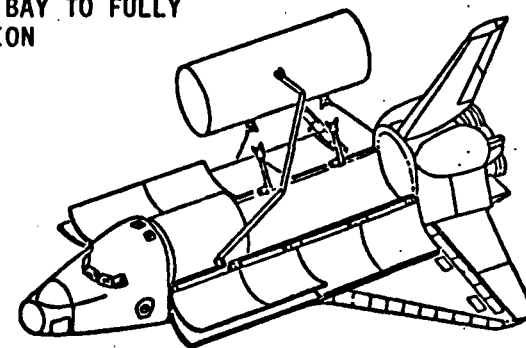

3

PAYLOAD GRAPPLLED BY MANIPULATOR,
PAYLOAD/PIDA INTERFACES UNDOCKED &
PAYLOAD POSITIONED FOR RELEASE

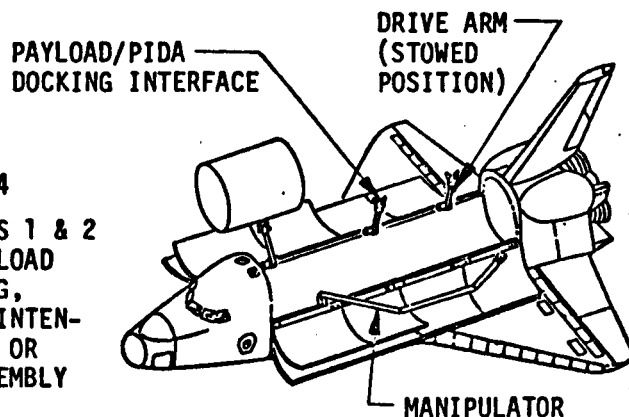

4

REPEAT STEPS 1 & 2
TO HOLD PAYLOAD
FOR POINTING,
INFLIGHT MAINTEN-
ANCE ACCESS OR
ORBITAL ASSEMBLY

FIGURE 1
DEPLOYMENT SEQUENCE

341

342

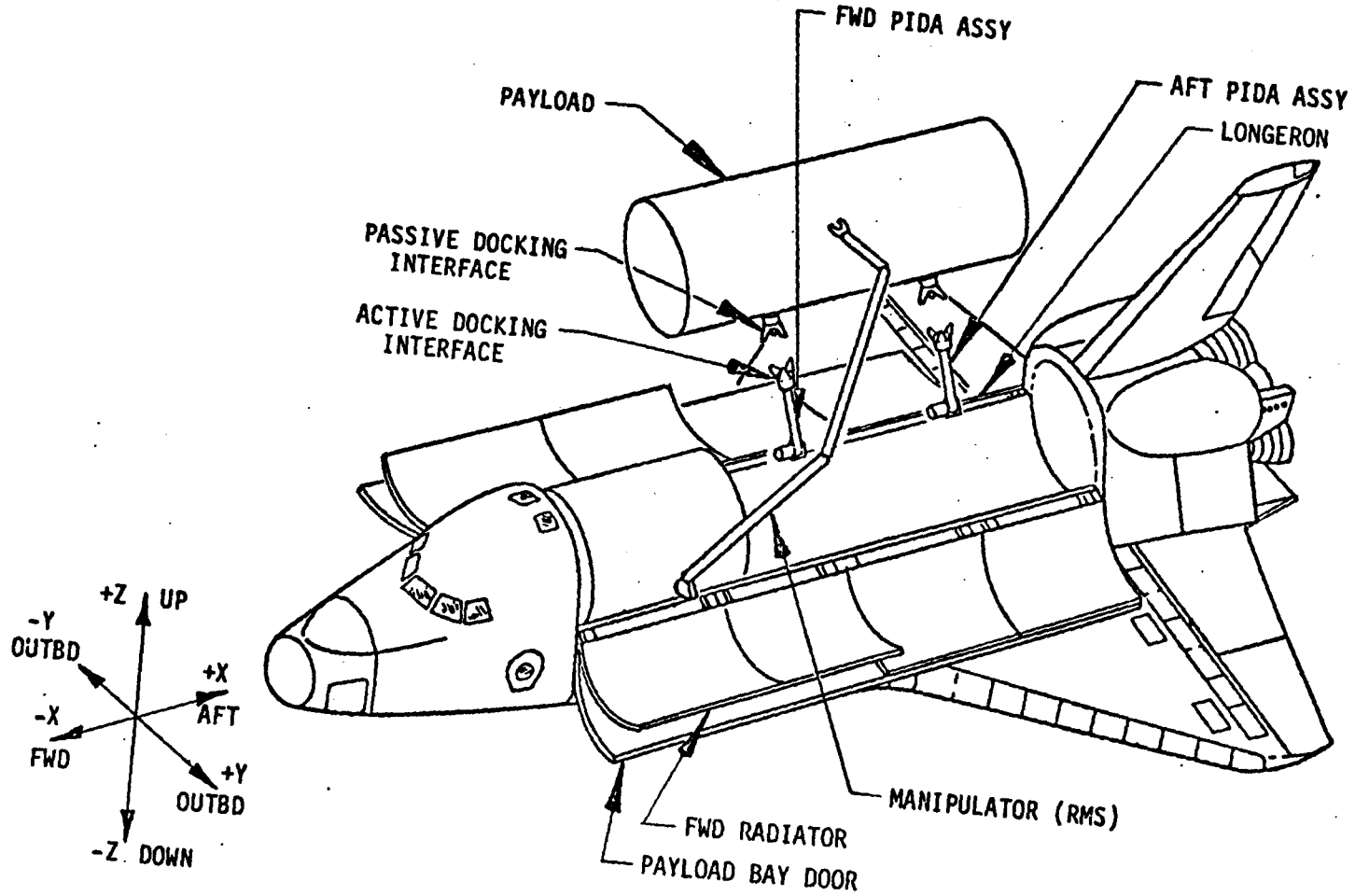
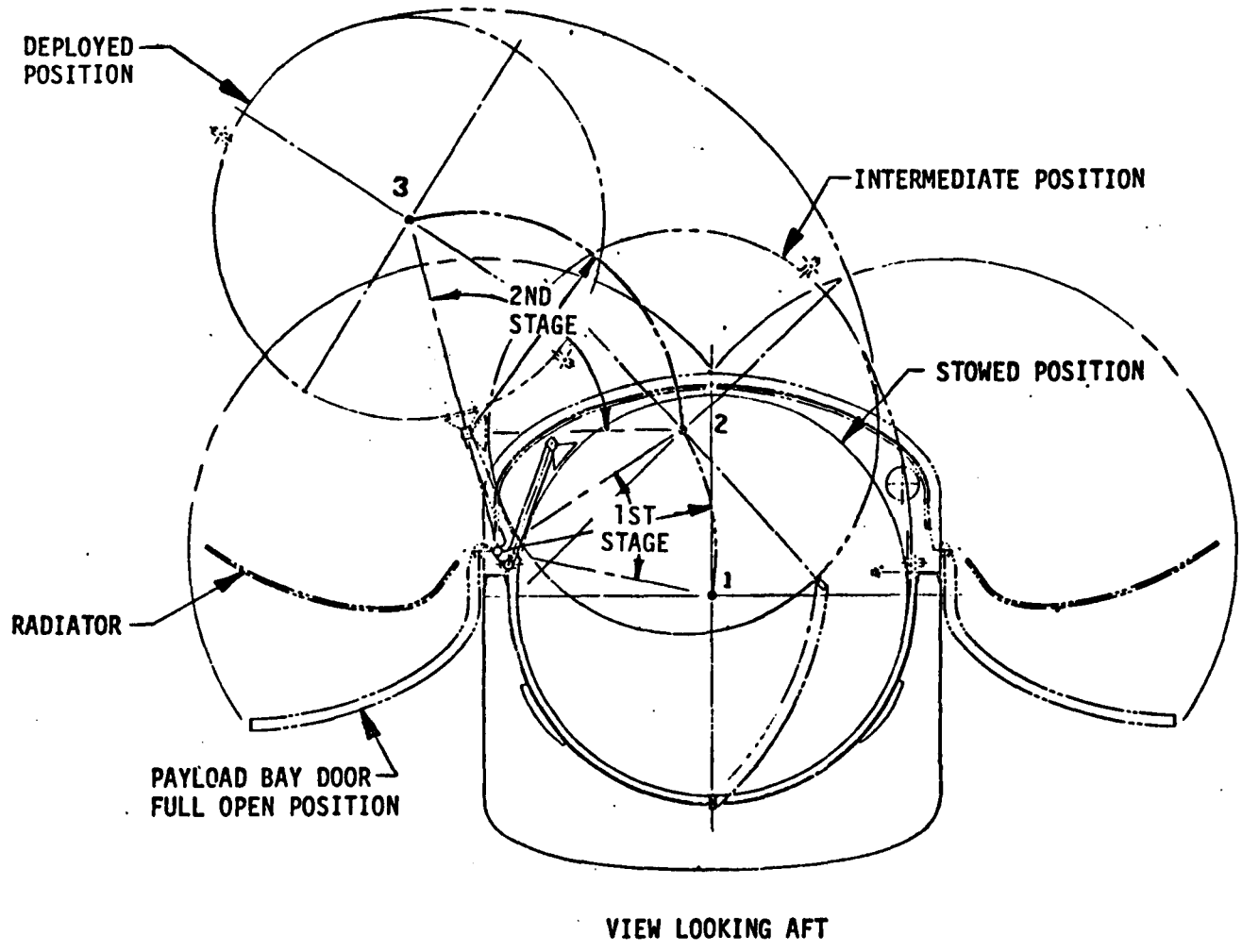

FIGURE 2
NOMENCLATURE

ORIGINAL PAGE IS
OF POOR QUALITY

343



ORIGINAL PAGE IS
OF POOR QUALITY

VIEW LOOKING AFT
FIGURE 3
2 STAGE DEPLOY/STOW ACTUATION

344

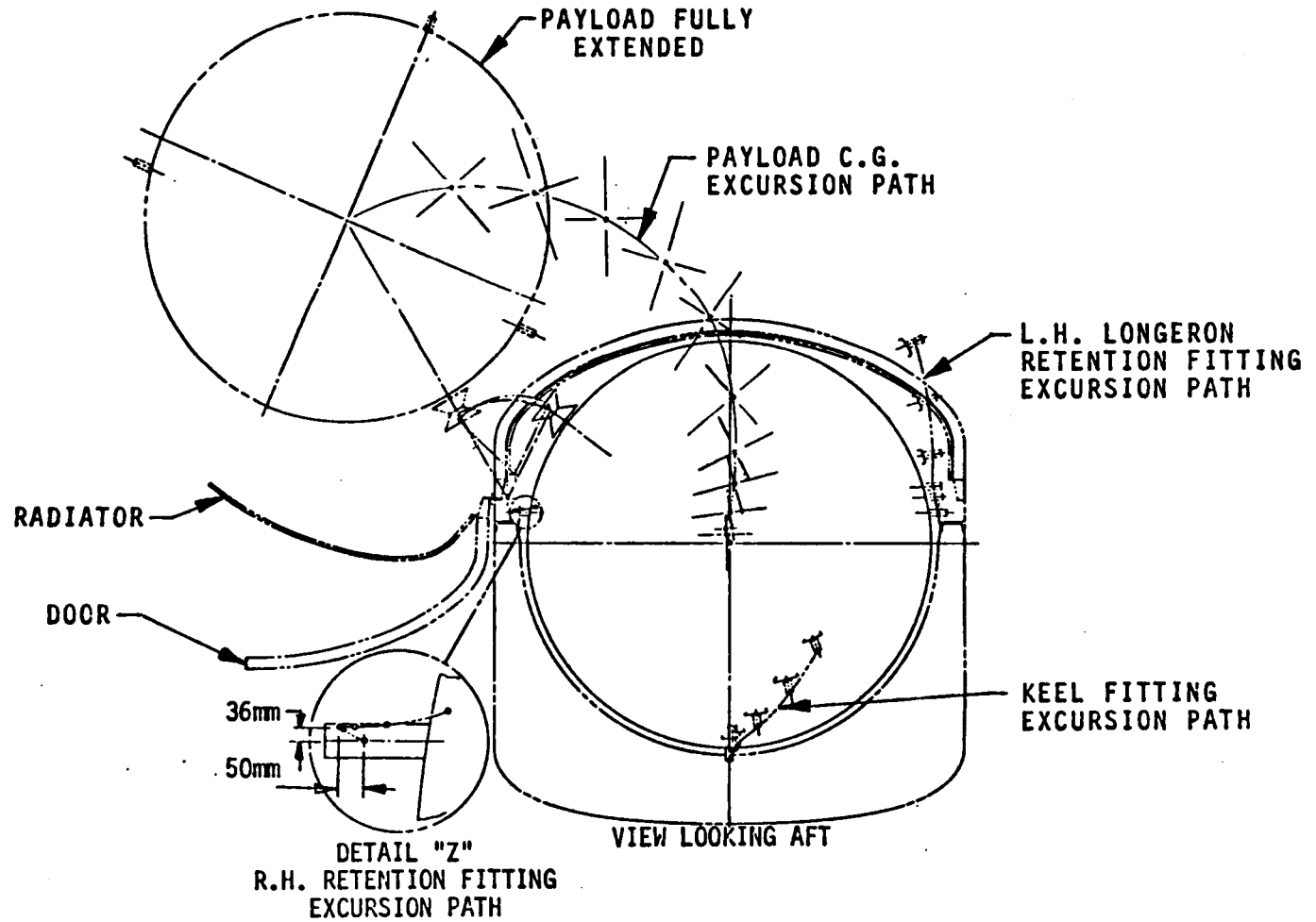

ORIGINAL PAGE IS
OF POOR QUALITY

FIGURE 4
SINGLE STAGE DEPLOY/STOW ACTUATION

ORIGINAL PAGE IS
OF POOR QUALITY

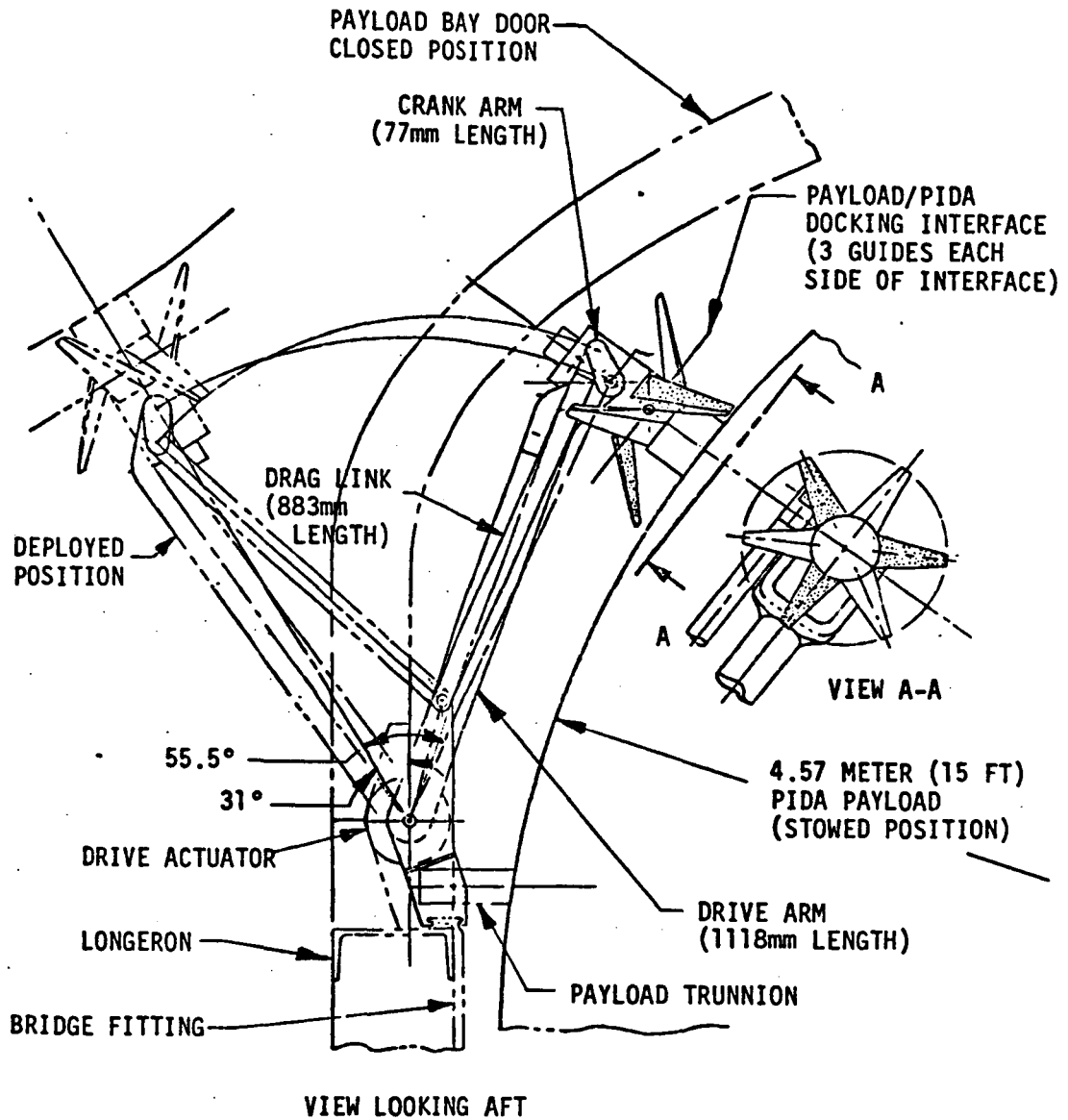

FIGURE 5
DEPLOY/STOW MECHANISM

ORIGINAL PAGE IS
OF POOR QUALITY

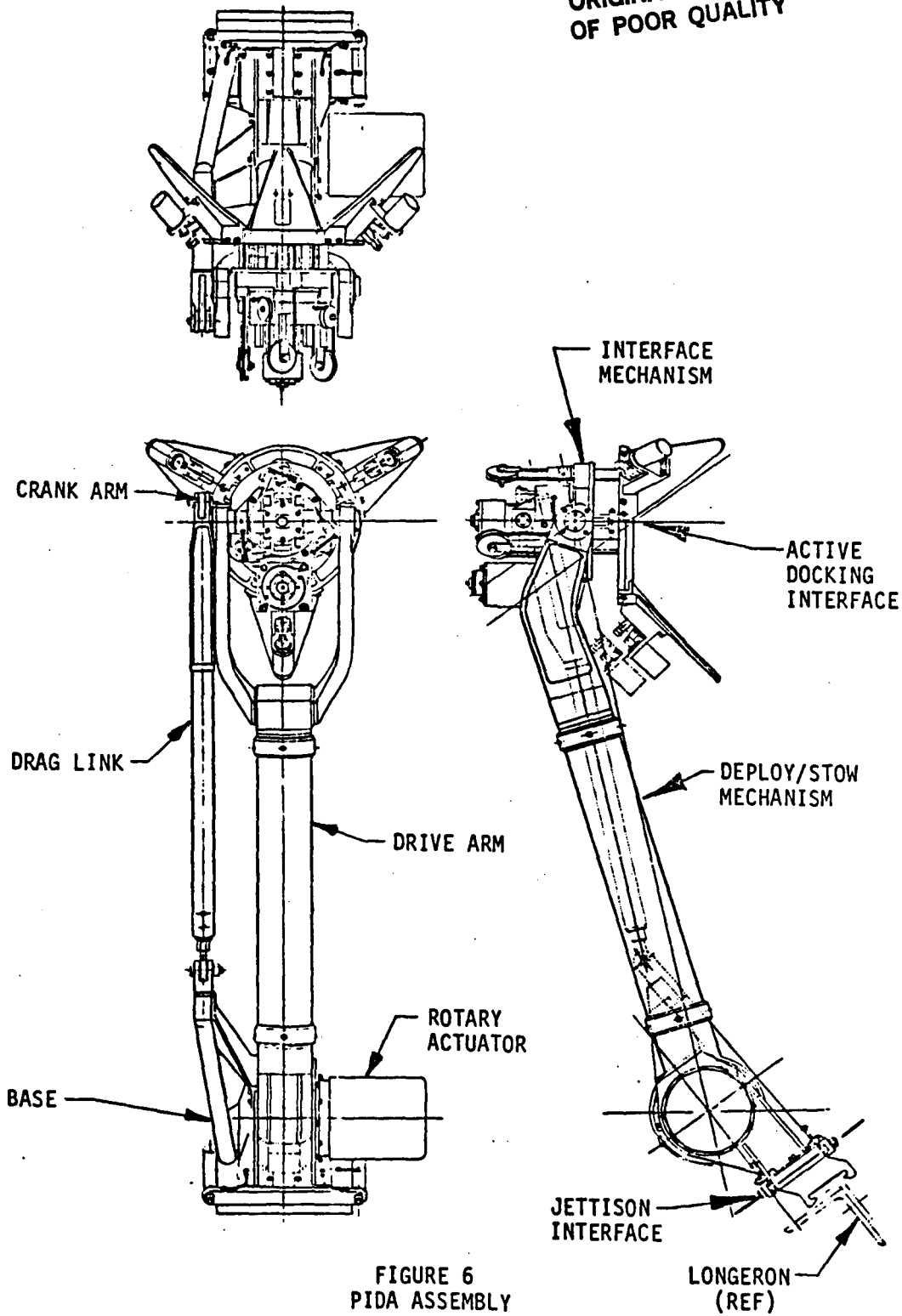

FIGURE 6
PIDA ASSEMBLY

ORIGINAL PAGE IS
OF POOR QUALITY

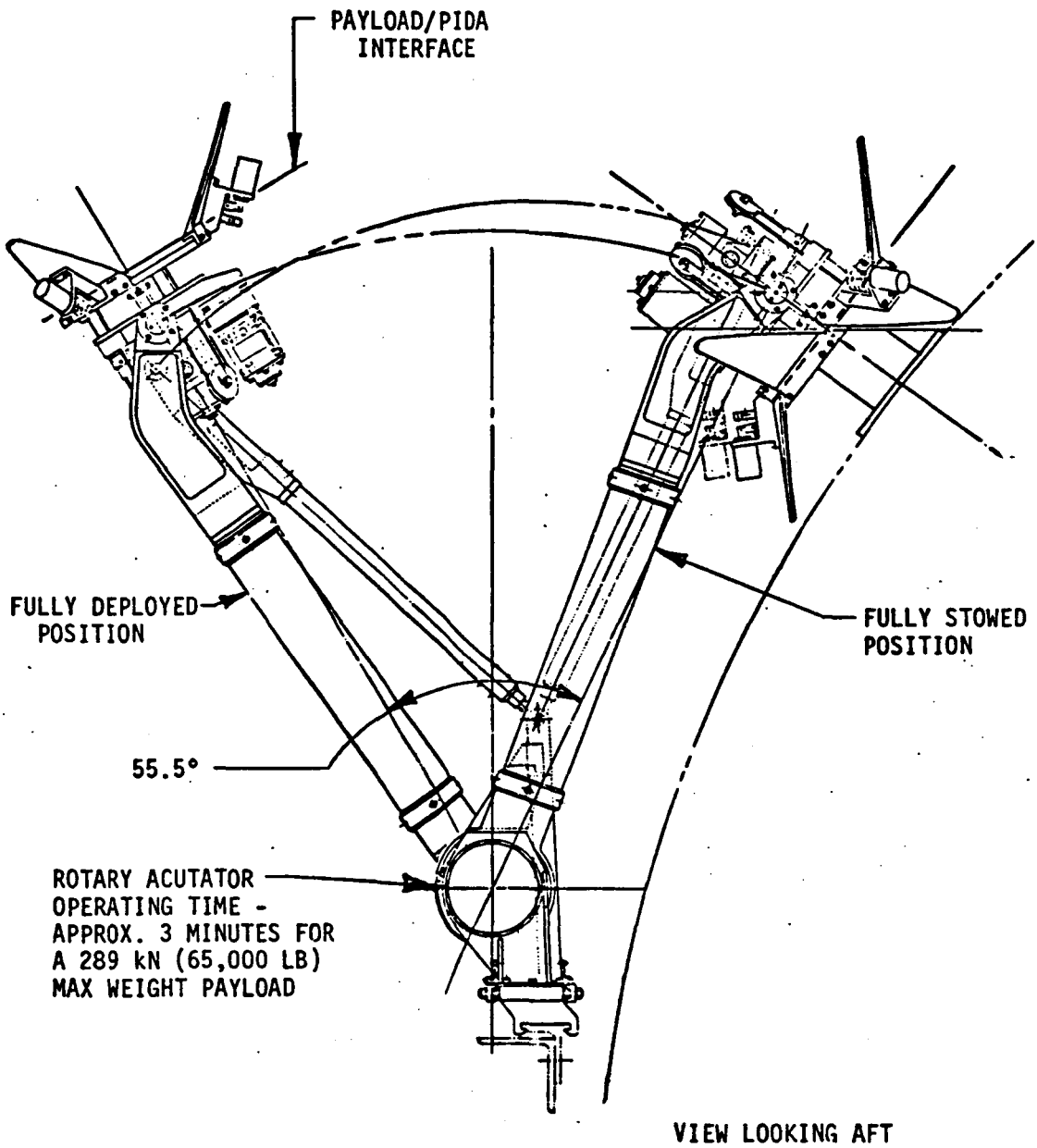

FIGURE 7
PIDA ASSY
OPERATING POSITIONS

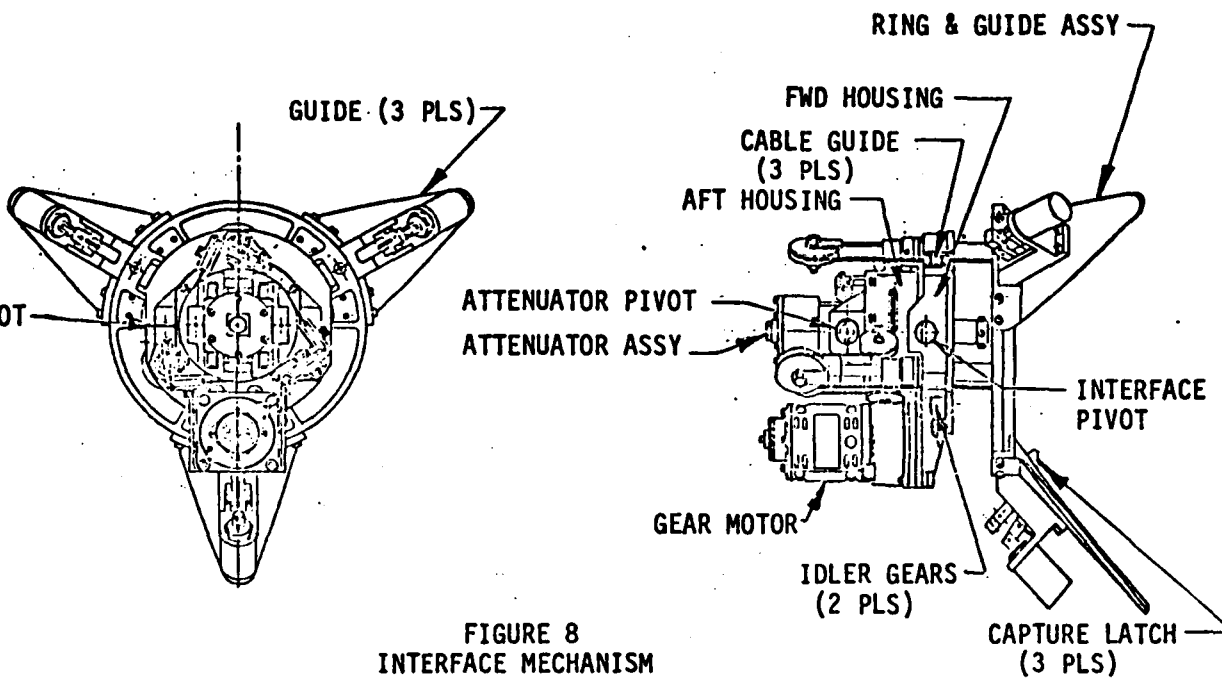
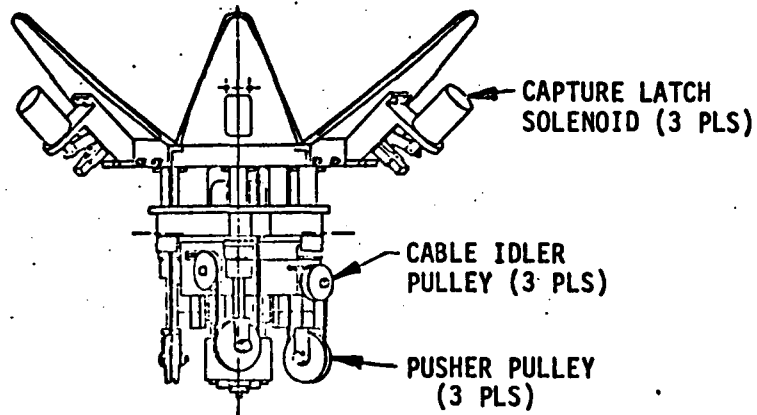
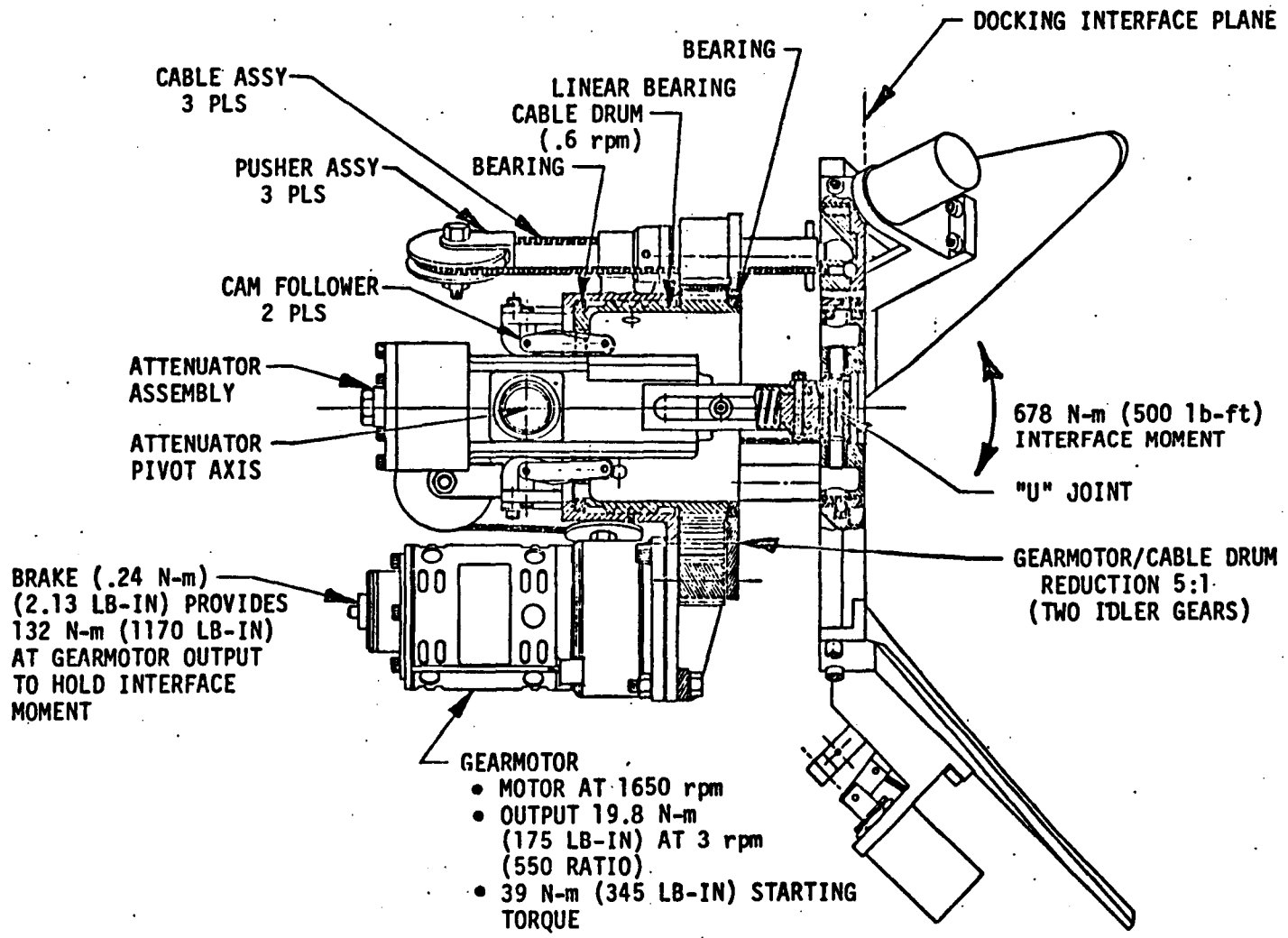

FIGURE 8
INTERFACE MECHANISM

ORIGINAL PAGE 19
OF POOR QUALITY

348



ORIGINAL PAGE IS
OF POOR QUALITY

FIGURE 9
INTERFACE MECHANISM

349

DA LNSB 11194

SATELLITE SERVICES

WORKSHOP

BERTHING/DOCKING

L A S E R D O C K I N G S E N S O R

HARRY ERWIN
TRACKING & COMMUNICATIONS
DEVELOPMENT DIVISION
JOHNSON SPACE CENTER

350

INTRODUCTION

Rendezvous and docking sensors are needed to support the future Earth-orbital operations of vehicles such as the Shuttle, the Teleoperator Maneuvering System (TMS), the Orbital Transfer Vehicle (OTV) and the maneuverable television system (MTV). We investigated the form such sensors should take and whether a single, possibly modular, sensor could satisfy the needs of all vehicles.

The sensor must enable an interceptor vehicle to determine both the relative position and the relative attitude of a target vehicle. Relative-position determination is fairly straightforward and places few constraints on the sensor. Relative-attitude determination, however, is more difficult. The method we have selected is to calculate the attitude based on relative position measurements of several reflectors placed in a known arrangement on the target vehicle.

The constraints imposed on the sensor by the attitude-determination method are severe. Narrow beamwidth, wide field of view (fov), high range accuracy, and fast random-scan capability are all required to determine attitude by this method. A consideration of these constraints as well as others imposed by expected operating conditions and the available technology has led us to conclude that the sensor should be a cw optical radar employing a semiconductor-laser transmitter and an image-dissector receiver.

The performance obtainable from a representative sensor was compared to specifications generated during the study and the conclusion was that this type of sensor can meet the needs of future Earth-orbital operations.

PURPOSE OF DOCKING SENSOR

Future space operations will require soft docking and/or maintenance of a fixed relative attitude while station-keeping. In either case, a versatile, lightweight sensor system will be needed to augment or replace visual tracking of the target vehicle. Massive or flexible spacecraft will require greater sensor system accuracy to minimize contact forces and moments, docking mechanism mass and complexity, vehicle dispersions, and fuel expenditures. In addition, a docking/station keeping sensor will enable long term station-keeping to be performed in an automatic mode to relieve the crew of the workload and tedium of monitoring relative positions and applying corrective maneuvers. Eventually, this sensor capability will enable automatic rendezvous and docking.

Well in advance of operational station-keeping and docking, a standard configuration for payload-mounted passive tracking aids needs to be established. This will enable payloads which are launched in the near future to be configured before launch for later retrieval. Therefore, it is important to start now to determine a viable station-keeping and docking tracking technique. This project establishes a workable docking sensor system and a standard target aid configuration.

DEVELOPMENT OF REQUIREMENTS

Three studies ^{1,2,3} have been completed establishing sensor performance, technology status, and conceptual design requirements for rendezvous, station-keeping, and docking. Inputs from numerous organizations and disciplines were incorporated in the studies, including spacecraft and docking mechanism designers; mission planners and analysts; guidance, navigation, and control specialists; and microwave/laser systems engineers. These studies concluded that development of a docking sensor capability is a critical need.

The Shuttle Ku-band Radar and Communication System will not suffice for close range station-keeping and docking for a number of reasons: (1) it does not measure attitude, (2) it cannot function effectively at ranges less than 100 feet, (3) it cannot perform its radar and communications functions simultaneously; therefore, payload and TV data cannot be transmitted while station-keeping and docking, and (4) it is too large and heavy to be used on other smaller vehicles, such as free flyers and teleoperator maneuvering systems, which will also require station-keeping and docking capabilities. A new system must, therefore, be developed to fulfill the close-range station-keeping and docking tracking requirements.

The studies also showed that: (1) because of the attitude measuring accuracies required for docking, a system operating at optical frequencies is required, and (2) a tracking system which is capable of supporting docking is also capable of supporting close range station-keeping.

Studies:

1. Advanced Rendezvous Sensor Study by RCA, NAS 9-16252, 1981 (906-75-23-01), Sponsored by JSC Tracking & Communications Development Division.
2. Development of Automated Rendezvous and Proximity Operations Techniques for Rendezvous and Close-in Operations and Satellite Servicing by LinCom Corp., NAS 9-16310, 1981 (906- - -), Sponsored by JSC Mission Planning and Analysis Division.
3. Final Report of the Space Vehicle Control and Guidance Working Group JSC/ K. Cox, Chairman, January 1982, Sponsored by OAST Space Systems Office.

FUTURE SPACE VEHICLES

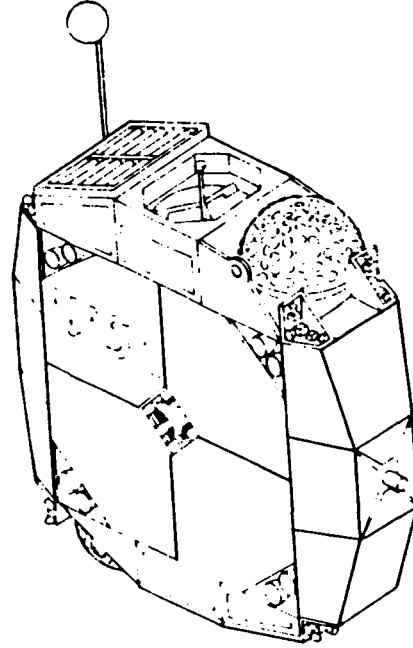

TMS

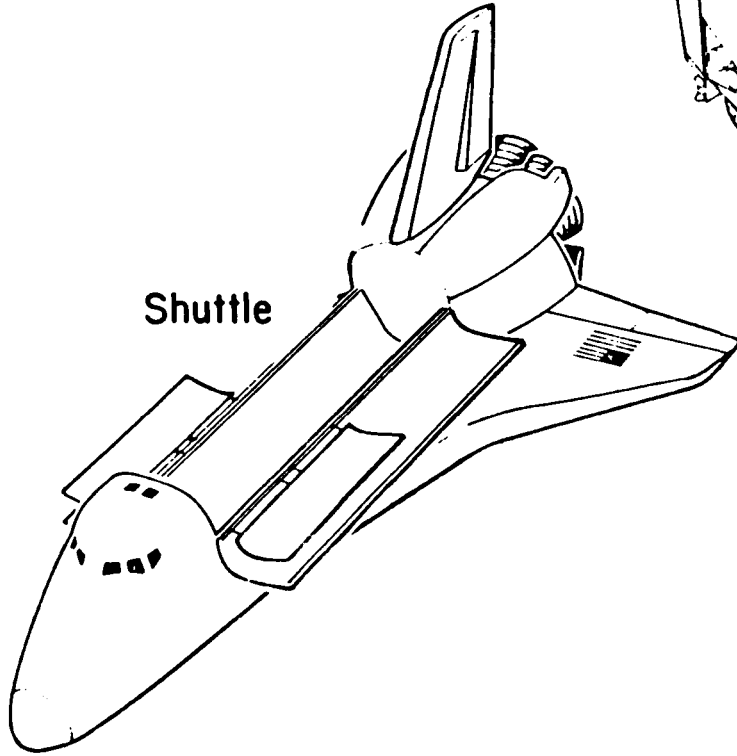

Shuttle

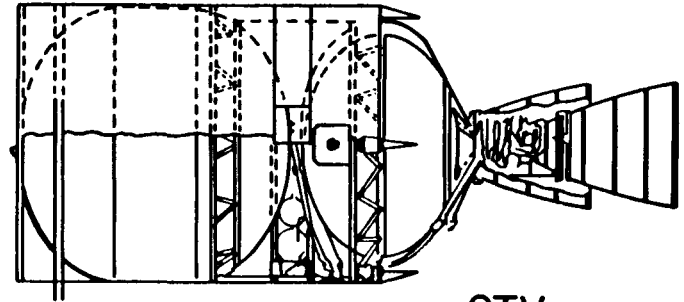

OTV

354

ORIGINAL PAGE IS
OF POOR QUALITY

RENDEZVOUS, STATIONKEEPING AND DOCKING

- INTERCEPTOR - PERFORMS ACTIVE MANEUVERS.
- TARGET - MAINTAINS PRESENT STATE.

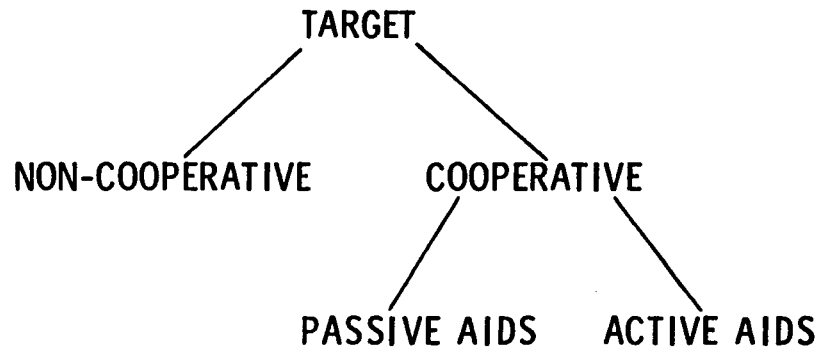

ORIGINAL PAGE IS
OF POOR QUALITY

355

TARGET STATUS ASSUMPTIONS

- CARRIES PASSIVE AIDS (SUCH AS REFLECTORS).
- MAINTAINS STABLE ATTITUDE.

358

DOCKING

- PHYSICAL CONTACT BETWEEN INTERCEPTOR AND TARGET.
- DOCKING MECHANISMS: HARD (IMPACT) AND SOFT (NON-IMPACT).
- HARD DOCKING MECHANISMS ARE NOT SUITABLE FOR THE DOCKING OF TWO LARGE VEHICLES.
- SENSOR REQUIREMENTS ARE MORE STRINGENT FOR DOCKING BY SOFT DOCKING MECHANISMS.
- CONCLUSION: SENSOR MUST SUPPORT SOFT DOCKING.

GENERAL CONDITIONS OF USE

- PASSIVE AIDS ON TARGET. (1 m DIAMETER SPACING CIRCLE)
- FUNCTION PROPERLY WHEN VIEWING OBJECTS AGAINST THE EARTH.
- TOLERATE VIEWING OF SUN WITHOUT DAMAGE.
- PROVIDE OWN SOURCE OF ILLUMINATION (SELF-CONTAINED).
- SMALL (.1 m³), LOW POWER (50 W), LONG LIFE (10⁴ HOURS).

359

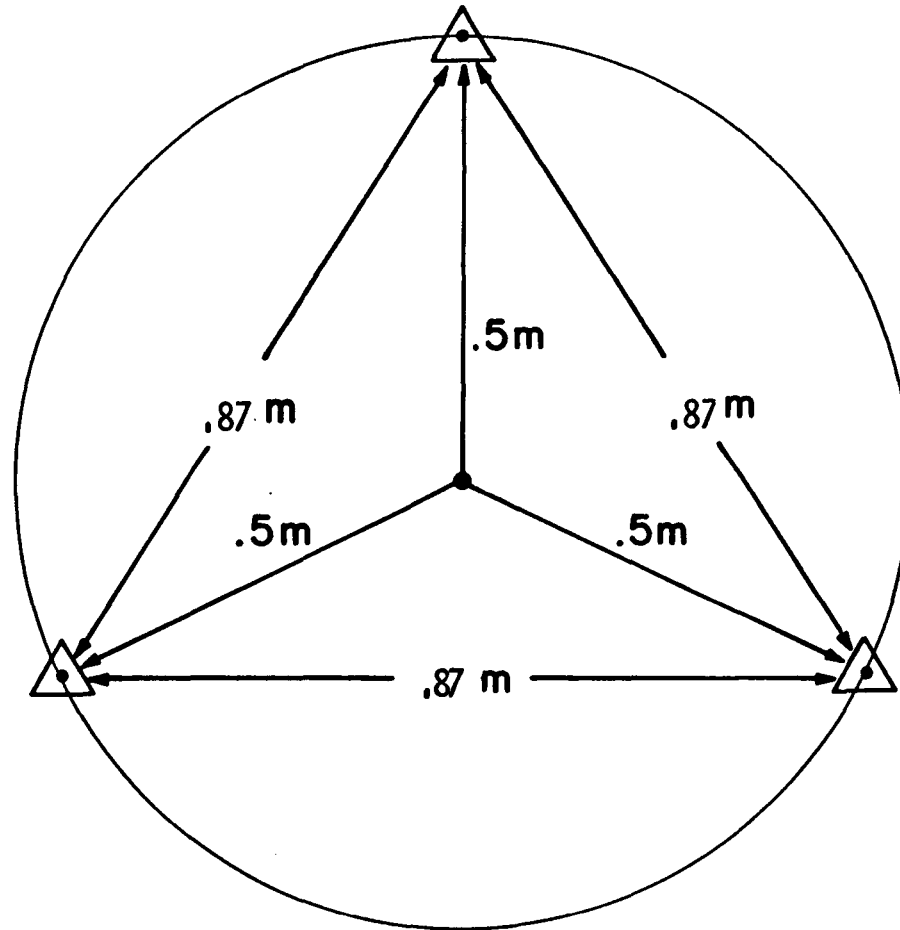

ORIGINAL PAGE IS
OF POOR QUALITY

SPACING OF DOCKING AIDS (REFLECTORS)

KEY COMPONENTS

- SEMICONDUCTOR LASERS
- BEAMSTEERERS
- REFLECTORS
- TELESCOPES
- OPTICAL FILTERS
- IMAGE DISSECTORS
- PHASE LOCK LOOPS
- CONTROLLERS

TRANSMITTER SOURCE

- SEMICONDUCTOR LASER
 - 800-900 nm WAVELENGTH
 - 10% EFFICIENCY
 - 10^5 HOURS LIFETIME
 - DIRECT DETECTION WITH UNCOOLED DETECTORS.

- Nd:YAG LASER
 - 1060 nm WAVELENGTH (530 nm FREQUENCY DOUBLED)
 - <1% EFFICIENCY (COOLING PROBLEMS)
 - 10^4 HOURS LIFETIME (PUMPING LAMPS HAVE LIMITED LIFETIME)
 - DIRECT DETECTION WITH UNCOOLED DETECTORS.

- CO₂ LASER
 - 10.6 μ m WAVELENGTH
 - 20% EFFICIENCY
 - 10^4 HOURS LIFETIME
 - REQUIRES HETERODYNE DETECTION WITH COOLED DETECTORS.

TRANSMITTER SOURCE (CONTINUED)

- CHOICE: SEMICONDUCTOR LASER
 - CO₂ LASERS HAVE MARGINAL RESOLUTION, REQUIRE COMPLEX DETECTION APPARATUS, AND HAVE A SHORT LIFE.
 - Nd:YAG LASERS HAVE LOW EFFICIENCY, COOLING PROBLEMS, AND A SHORT LIFE.

REFLECTORS: CUBE CORNER

- IDEALLY RETURNS ALL BEAMS IN DIRECTION THEY ORIGINATED FROM.
- REVERSES POLARIZATION.
- EFFECTIVE APERTURE VARIES WITH ANGLE.
- ACTUAL BEAMWIDTH IS:

$$\theta_{CC} = \theta_{in} + \theta_{Return} + \theta_{Divergence}$$

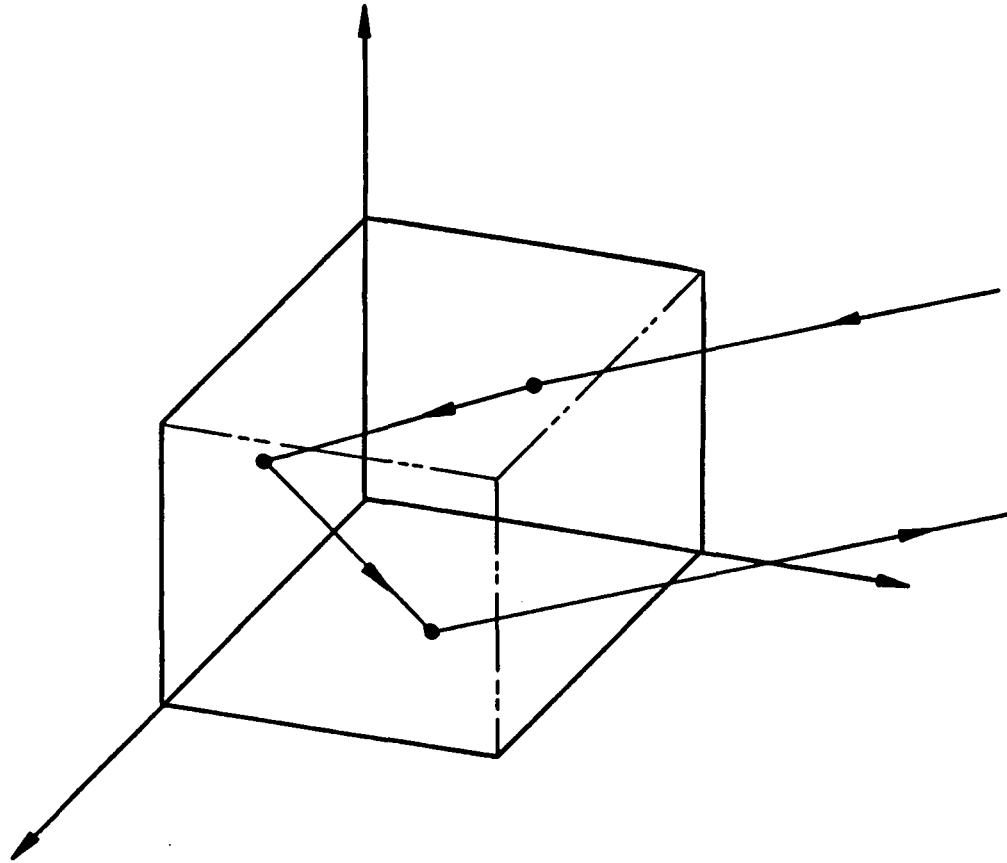

CORNER REFLECTOR

IMAGE DISSECTOR

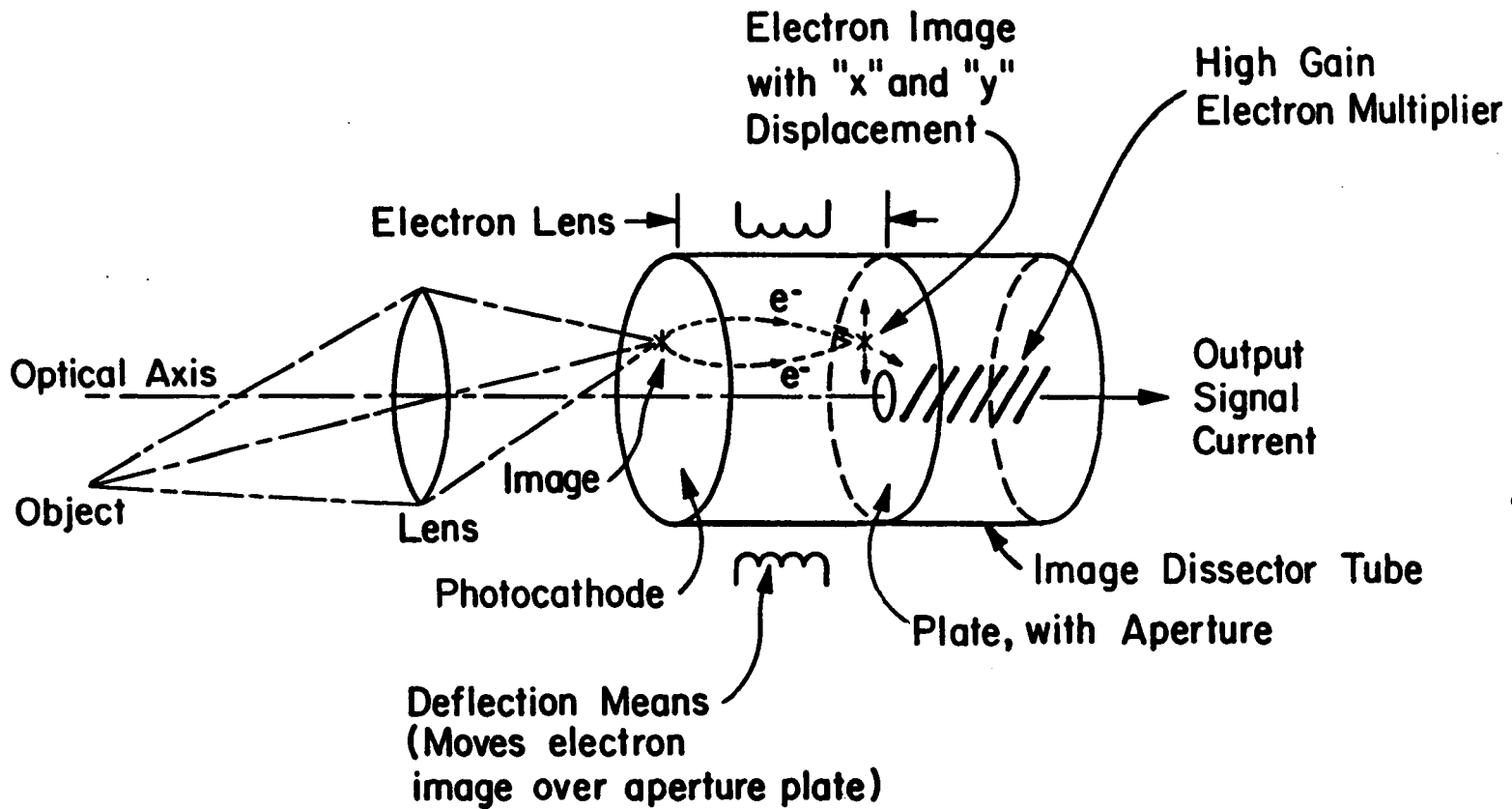

ORIGINAL PAGE IS
OF POOR QUALITY

365

STANDARD PHOTOCATHODE RESPONSE

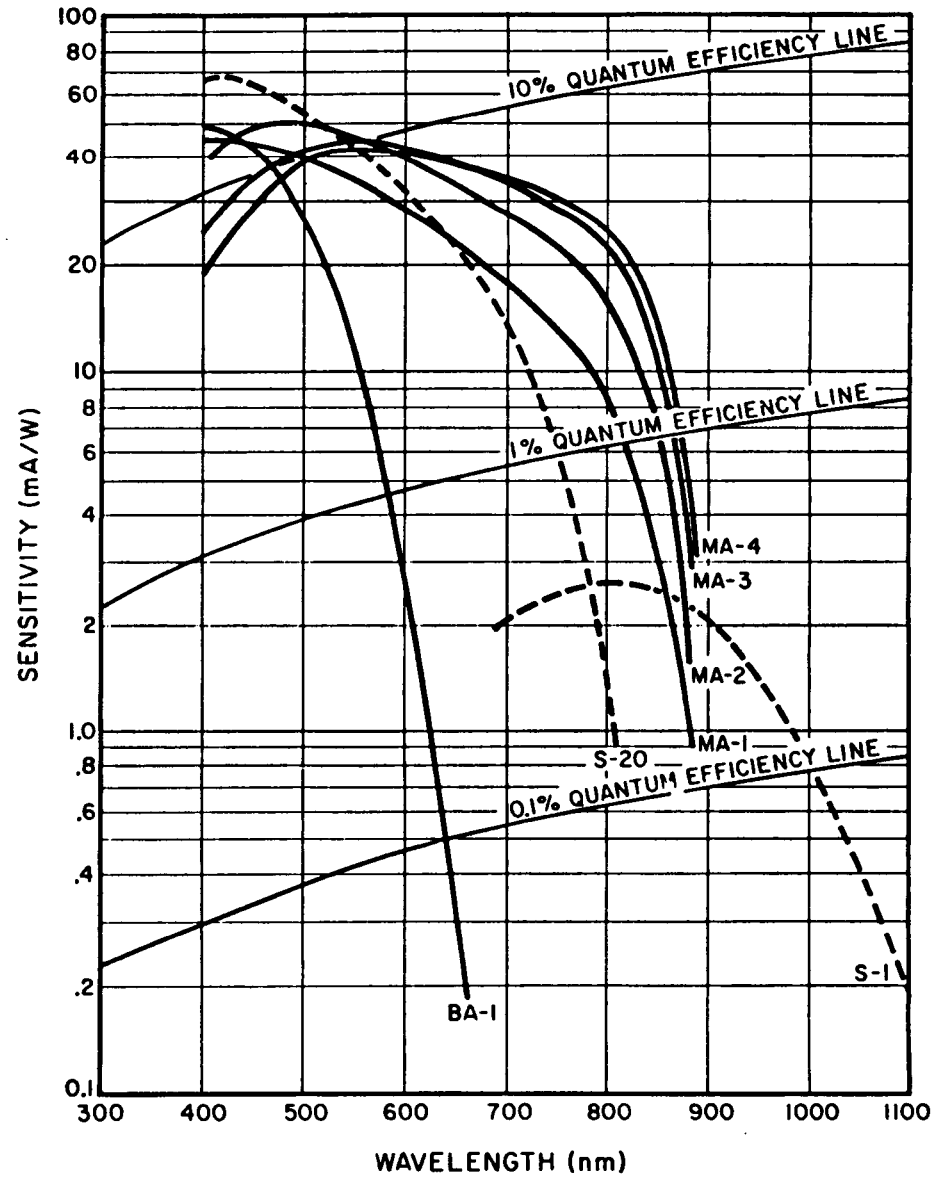

366

ORIGINAL PAGE IS
OF POOR QUALITY

367

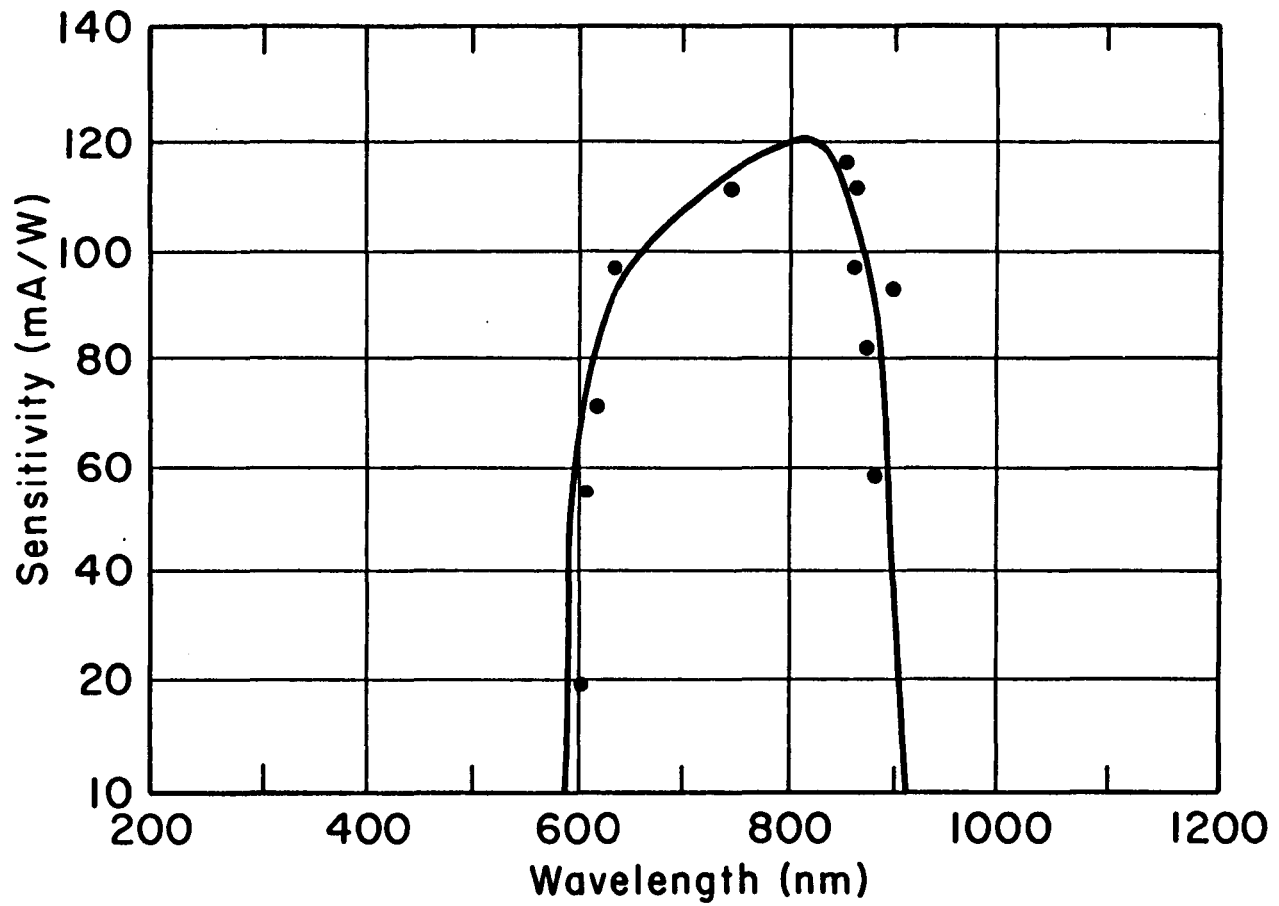

GaAs PHOTOCATHODE RESPONSE

ORIGINAL PAGE IS
OF POOR QUALITY

MODULATION TECHNIQUES

- ASSUMPTIONS:
 - SEMICONDUCTOR LASER SOURCE
 - DIRECT MODULATION (VIA CURRENT CONTROL)
 - DIRECT DETECTION

- TYPES:
 - PULSE
 - IM-CW (AM-CW, PM-CW, FM-CW NOT POSSIBLE)
 - SUBCARRIER (MODULATED SUBCARRIER) (PULSE, PM-CW, FM-CW) - INTENSITY MODULATES OPTICAL CARRIER.

- CHOICE: IM-CW
 - PULSE MODULATION CANNOT ACHIEVE DESIRED ACCURACIES.
 - SUBCARRIER MODULATION WASTES POWER IN RESIDUAL CARRIER. (MIGHT BE USEFUL FOR DUAL PURPOSE SENSOR (TRACKING AND COMMUNICATIONS)).

368

ORIGINAL PAGE IS
OF POOR QUALITY

TONE RANGING: CONSTRAINTS

- IT IS PREFERABLE TO RANGE WITH ONE TONE RATHER THAN MULTIPLE TONES SINCE ALL POWER CONTRIBUTES TO ACCURACY.

- IF ONE TONE IS USED, ITS FREQUENCY MUST BE LESS THAN

$$f_{\max} = C/2 \cdot R_{\max}$$

TO AVOID AMBIGUITIES DUE TO MULTIPLE WAVELENGTH RANGES.

- IF ONE TONE IS USED, ITS FREQUENCY MUST BE GREATER THAN

$$f_{\min} = \frac{C}{K \cdot \Delta R}$$

WHERE: K = # OF CLOCK CYCLES IN ONE CYCLE OF MEASURED TONE.

ΔR = DESIRED RANGE RESOLUTION.

ORIGINAL PAGE IS
OF POOR QUALITY

Sensor Field of View: .5 rad (28.6°)

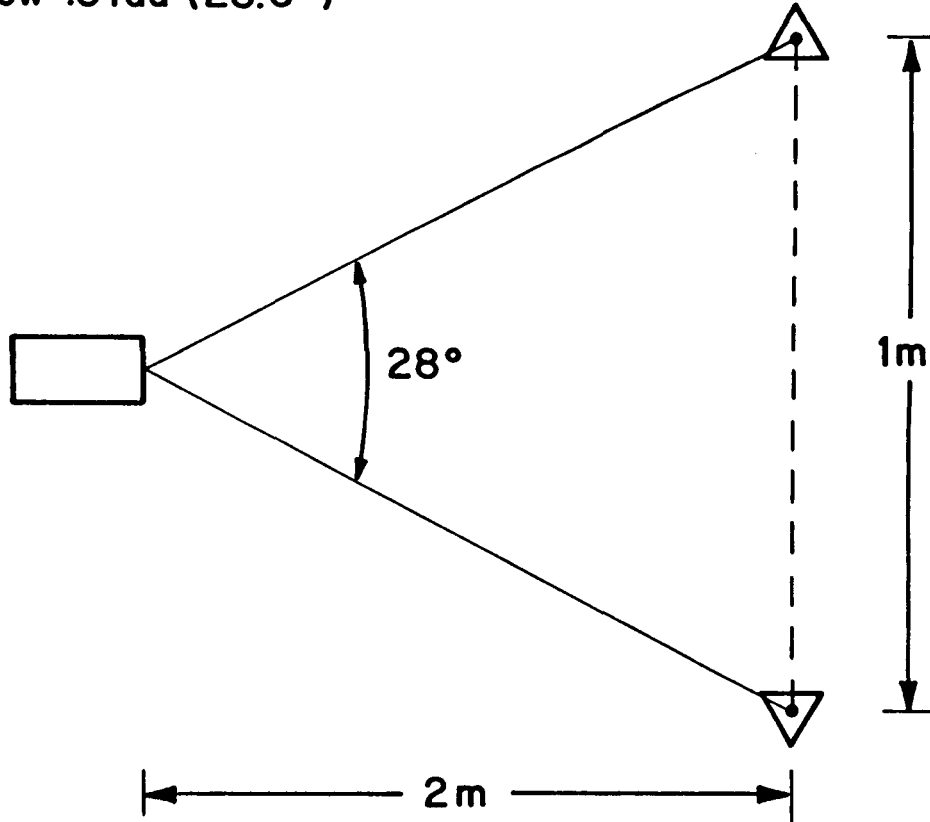

FIELD OF VIEW

370

ORIGINAL PAGE IS
OF POOR QUALITY

Sensor Beamwidth: 2 mrad

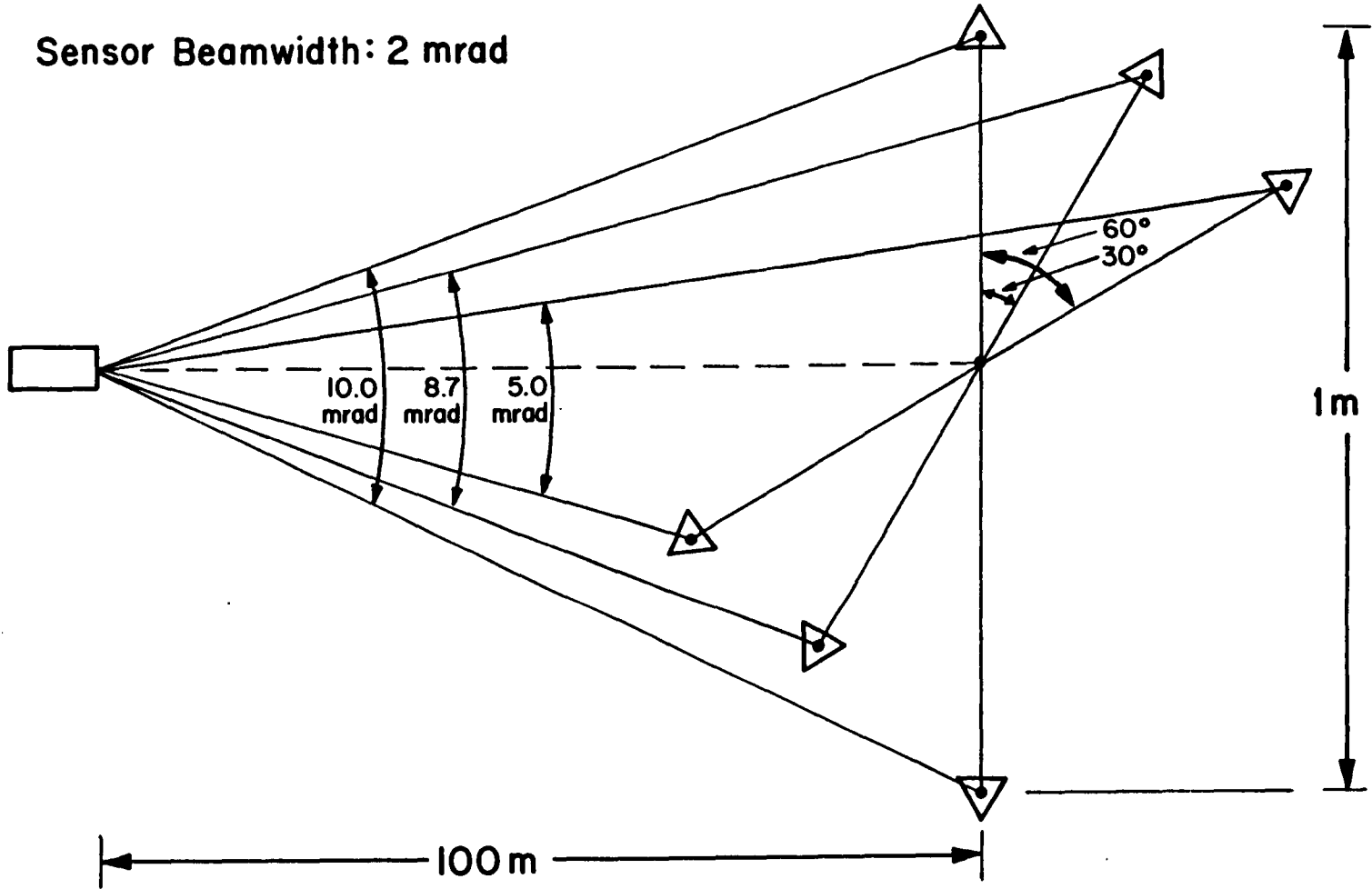

371

BEAMWIDTH
(TRANSMITTER & RECEIVER)

ORIGINAL PAGE IS
OF POOR QUALITY

FREQUENCY

- MINIMUM ALLOWABLE CARRIER FREQUENCY IS DETERMINED BY BEAMWIDTH AND APERTURE SIZE.
- THE MINIMUM POSSIBLE (DIFFRACTION-LIMITED) BEAMWIDTH ACHIEVABLE WITH A CIRCULAR APERTURE IS OBTAINED WHEN THE ILLUMINATION IS UNIFORM AND IS GIVEN BY

$$\theta = \frac{1.02 \cdot \lambda}{D}$$

WHERE: λ = WAVELENGTH = c/f

D = APERTURE DIAMETER

θ = BEAMWIDTH (RADIAN)

TRANSMISSION CHARACTERISTICS OF A CIRCULAR APERTURE

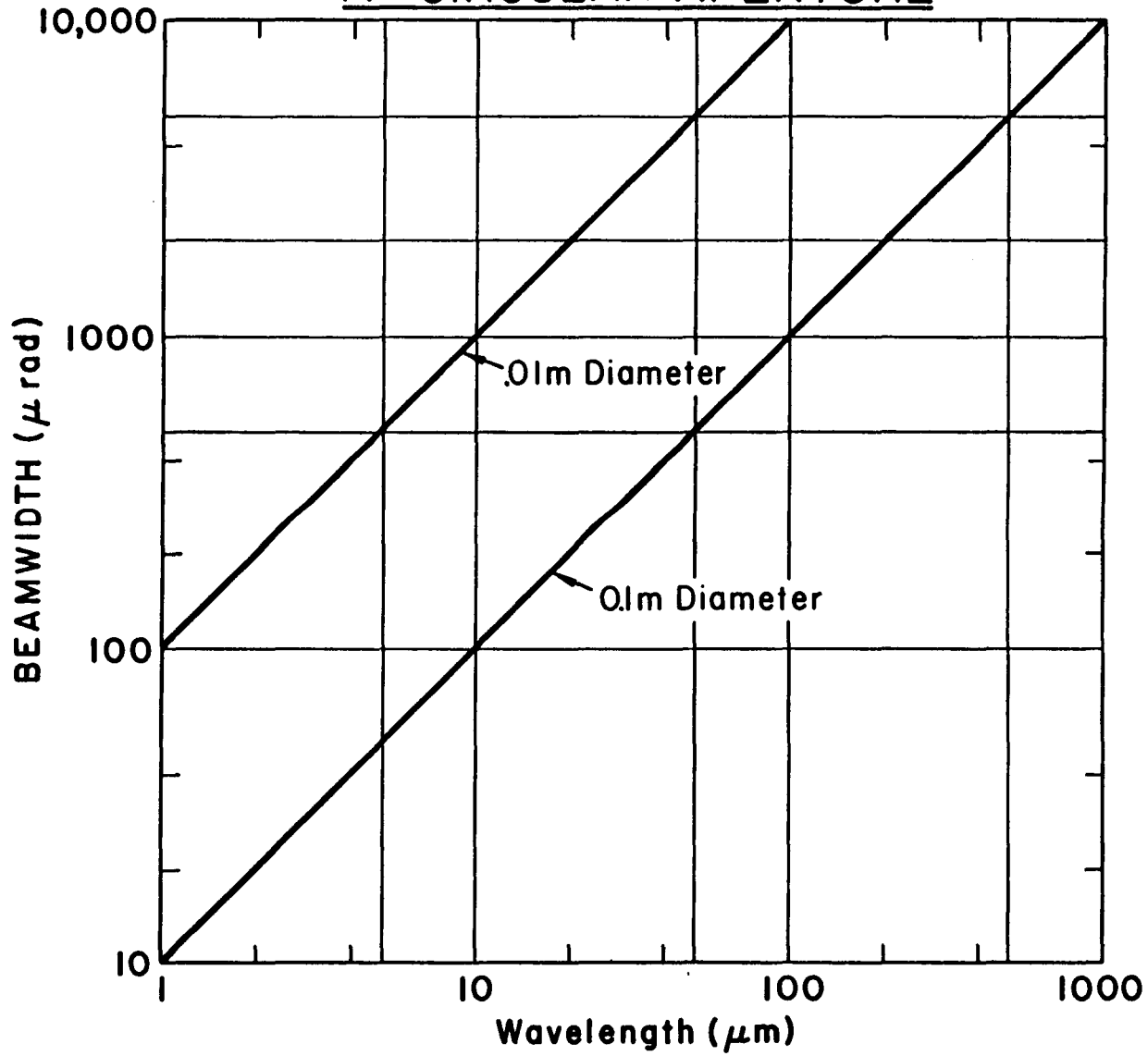

ORIGINAL PAGE IS
OF POOR QUALITY

FREQUENCY (CONTINUED)

- ASSUME:
 - CIRCULAR APERTURE LESS THAN .1 m.
 - ACTUAL BEAMWIDTH TWICE DIFFRACTION LIMIT.

- CONCLUSION (FROM PREVIOUS GRAPH):
 - OPERATING WAVELENGTH MUST BE LESS THAN 10 μm .

374

ORIGINAL PAGE IS
OF POOR QUALITY

SEARCH PATTERNS

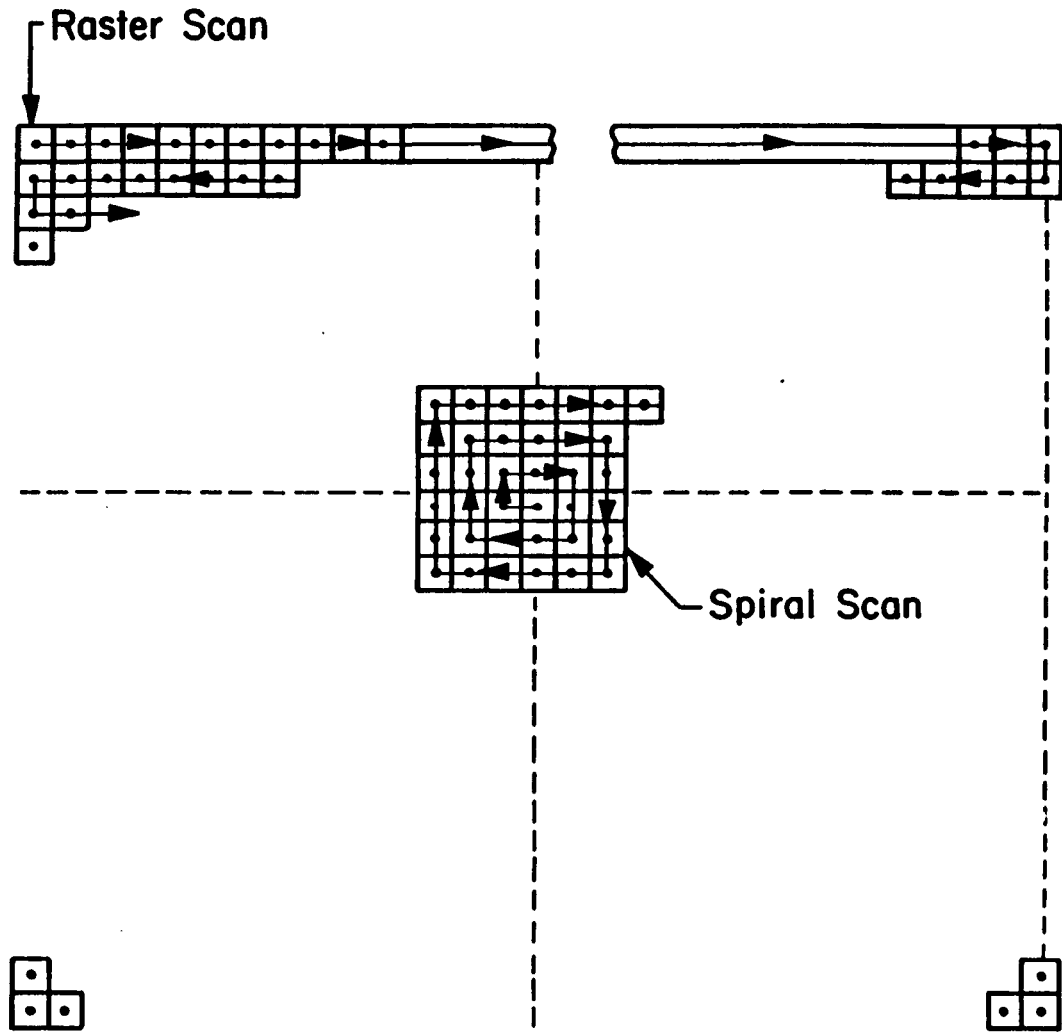

ORIGINAL PAGE IS
OF POOR QUALITY

375

TRACKING PATTERN (Sequential Lobing)

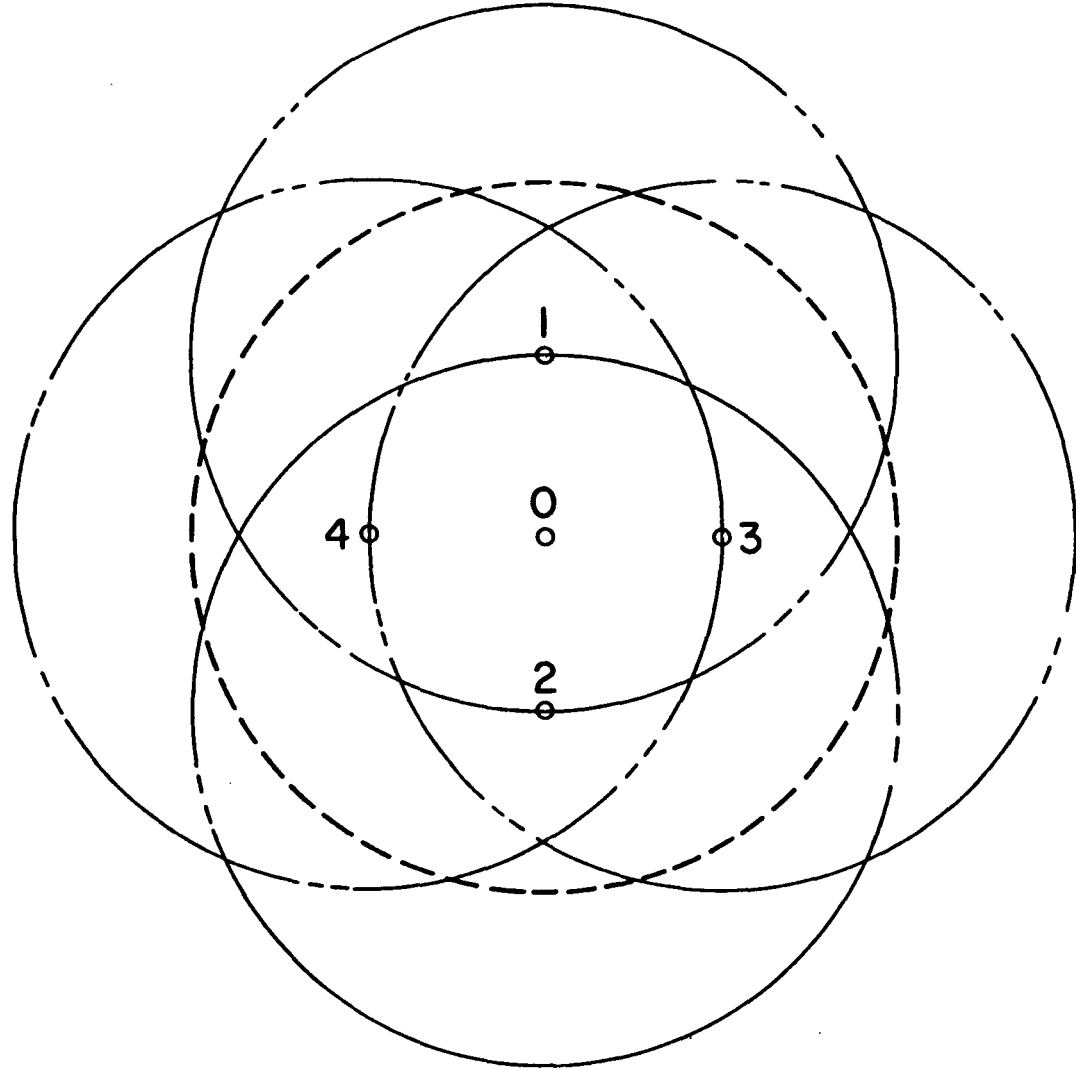

376

ORIGINAL PAGE IS
OF POOR QUALITY

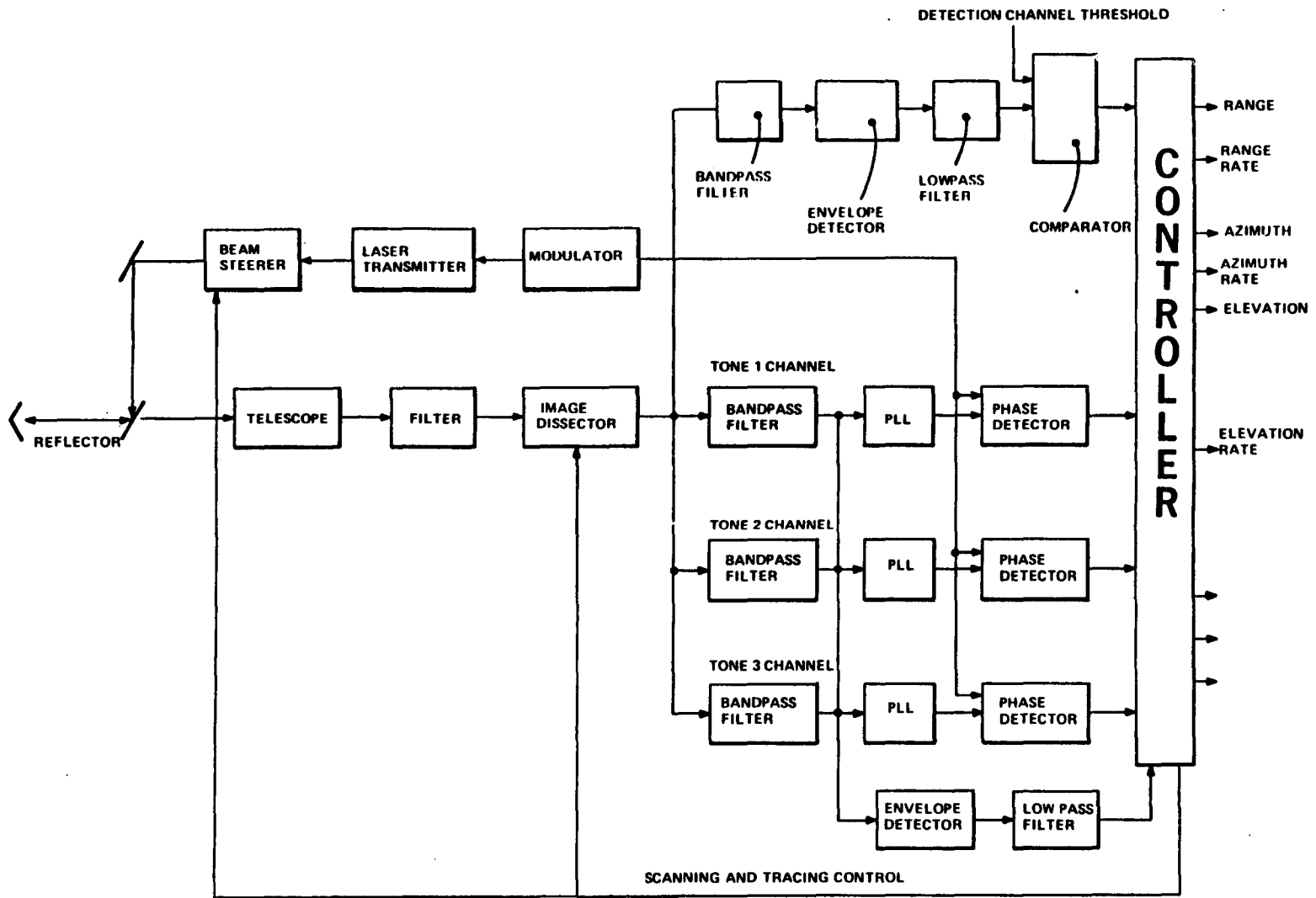

RENDEZVOUS AND DOCKING SENSOR

377

ORIGINAL PAGE IS
OF POOR QUALITY

LASER DOCKING SYSTEM FLIGHT DEMONSTRATION

TRACKING & COMMUNICATIONS DEV. DIV.

H. O. ERWIN

● PURPOSE

- TO FLIGHT DEMONSTRATE A LASER SYSTEM CAPABLE OF MEASURING POSITION AND ATTITUDE BETWEEN TWO STATION-KEEPING OR DOCKING VEHICLES.

● METHOD

- UPGRADE RTOP-DEVELOPED DOCKING SENSOR TO FLIGHT DEMONSTRATION QUALITY.
- ATTACH THE LASER SENSOR TO THE ORBITER EITHER IN THE PAYLOAD BAY OR ON THE MANIPULATOR ARM.
- PLACE SMALL PASSIVE REFLECTORS ON TARGETS TO BE RETRIEVED (E.G. LDEF).
- TRACK REFLECTORS ANGLES AND RANGES.
- CALCULATE COMPLETE POSITION AND ATTITUDE INFORMATION NEEDED TO PERFORM AUTOMATIC DOCKING OR STATION-KEEPING.

378

ORIGINAL PAGE IS
OF POOR QUALITY

LASER DOCKING SYSTEM FLIGHT DEMONSTRATION (CONT'D)

TRACKING & COMMUNICATIONS DEV. DIV.

H. O. ERWIN

● JUSTIFICATION

- AUTOMATIC STATION-KEEPING AND DOCKING CAPABILITY WILL SAVE FUEL AND CREW TIME AND WILL IMPROVE THE SAFETY OF THESE MANEUVERS.
- THE PRECISION OF MEASUREMENTS REQUIRED FOR AUTOMATIC DOCKINGS IS POSSIBLE ONLY WITH A LASER TYPE SYSTEM.
- USING THIS SYSTEM FOR STATION-KEEPING FREES THE KU-BAND SYSTEM FOR DATA TRANSMISSION. IF KU-BAND IS TRACKING FOR STATION-KEEPING, COMMUNICATIONS THROUGH TDRS ARE LIMITED TO 32 KBPS.
- THE SMALL SIZE AND WEIGHT OF THE LASER SENSOR WILL ALLOW IT TO BE USED ON SMALLER VEHICLES SUCH AS MTV, TMS, IUS, ...ETC.
- A STANDARD REFLECTOR CONFIGURATION FOR ALL FUTURE RETRIEVABLE OBJECTS NEEDS TO BE DEFINED NOW. THIS DEMONSTRATION WILL HELP MAKE THIS HAPPEN.

379

ORIGINAL PAGE IS
OF POOR QUALITY

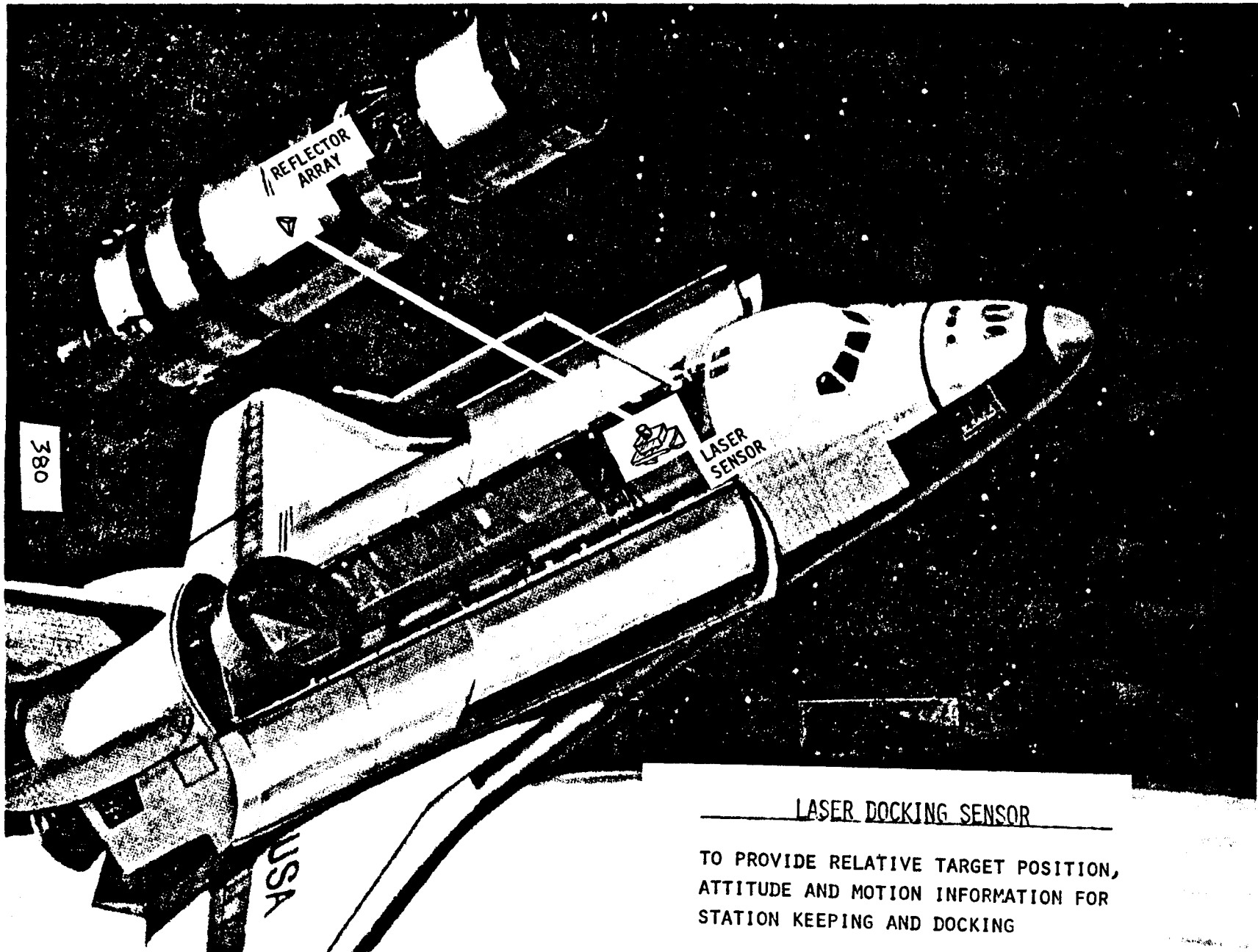

380

REFLECTOR
ARRAY

LASER
SENSOR

USA

LASER DOCKING SENSOR

TO PROVIDE RELATIVE TARGET POSITION,
ATTITUDE AND MOTION INFORMATION FOR
STATION KEEPING AND DOCKING

ORIGINAL PAGE IS
OF POOR QUALITY

381

FLUIDS MANAGEMENT TECHNOLOGY

ORIGINAL PAGE IS
OF POOR QUALITY.

John M. McGee
NASA Johnson Space Center
June 23, 1982

11195

FLUIDS MANAGEMENT TECHNOLOGY

PROPULSION AND POWER DIVISION

JOHN M. MCGEE

6/23/82

TECHNOLOGY BACKGROUND

- APOLLO
 - ELECTRIC POWER-CRYOGENIC HYDROGEN, OXYGEN-SUPERCRITICAL (SINGLE PHASE)
 - RCS (REACTION CONTROL SYSTEM) HYPERGOLIC PROPELLANTS, DIAPHRAGM EXPULSION
 - OMS (ORBITER MANEUVERING SYSTEM) - HYPERGOLIC PROPELLANTS, SETTling BY RCS
 - S IV B UPPER STAGE - TRANSLUNAR IGNITION, RCS SETTling OF SUBCRITICAL CRYOGENICS

- VIKING
 - PROPULSION - HYPERGOLIC, OPENVANE CAPILLARY ACQUISITION

- CENTAUR
 - PROPULSION - RCS SETTling OF SUBCRITICAL CRYOGENICS

382

30111 88M

ORIGINAL PAGE IS
OF POOR QUALITY

FLUIDS MANAGEMENT TECHNOLOGY

PROPULSION AND POWER DIVISION

JOHN M. MCGEE

6/23/82

VIKING ORBITER TANK AND PROPELLANT MANAGEMENT DEVICE

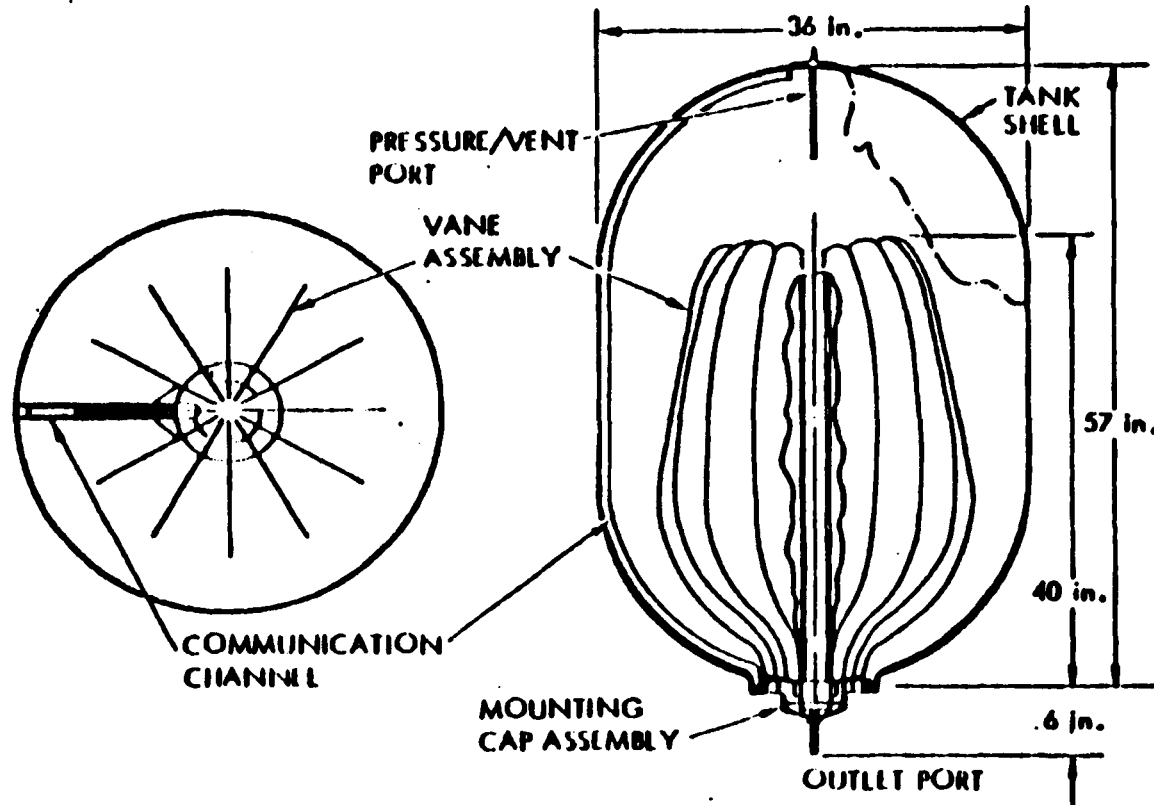

383

ORIGINAL PAGE IS
OF POOR QUALITY

FLUIDS MANAGEMENT TECHNOLOGY

PROPULSION AND POWER DIVISION

JOHN M. MCGEE

6/23/82

CURRENT TECHNOLOGY (SHUTTLE)

- ELECTRIC POWER - SUPERCRITICAL CRYOGENICS

- RCS - HYPERGOLICS, CAPILLARY SCREEN ACQUISITION

- OMS - HYPERGOLICS, CAPILLARY SCREEN ACQUISITION

- AUXILLIARY POWER UNIT - HYPERGOLIC, DIAPHRAGM EXPULSION

384

ORIGINAL PAGE IS
OF POOR QUALITY

FLUIDS MANAGEMENT TECHNOLOGY

PROPULSION AND POWER DIVISION

JOHN M. MCGEE

6/23/82

ORBITER PRSA LH₂ TANK

ORIGINAL PAGE IS
OF POOR QUALITY

TANK CHARACTERISTICS

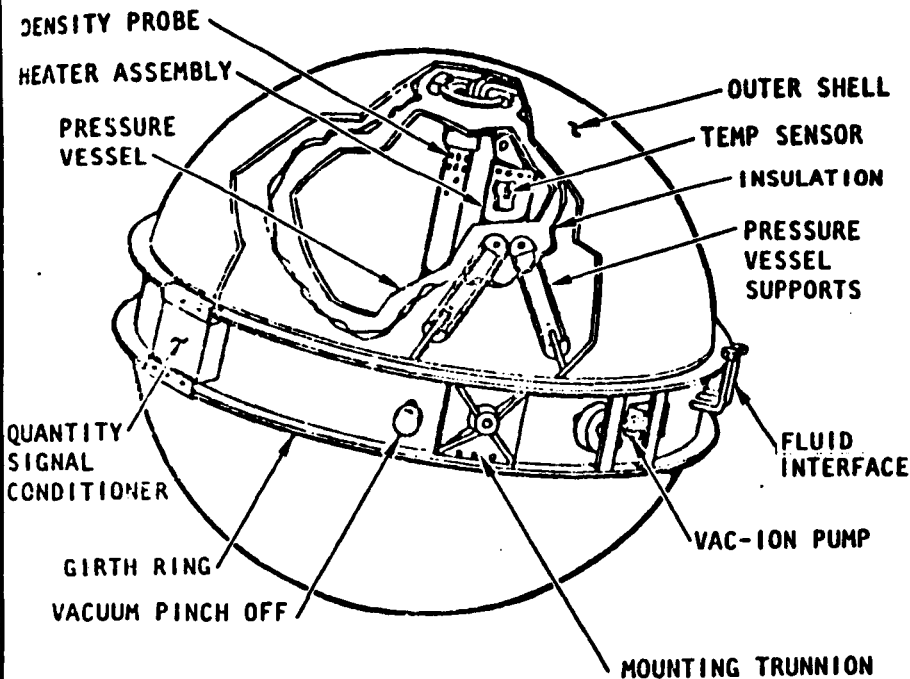

- **PRESSURE VESSEL**
 - MAX OPER PRESS. 315 PSIA
 - MATERIAL 2219 AL
 - ID 41.5 IN.
 - VOL 21.4 CU FT
 - WALL THICKNESS 0.112 IN.
 - SUPPORT TENSION SUSPENSION STRAFS
- **INSULATION** DOUBLE SILVERIZED MLI/NYLON NET SPACERS
- **VAPOR COOLED SHIELD** —
- **TANK MOUNTING** 3-POINT TRUNNION SUPPORTS THROUGH GIRTH RING

HEAT LEAKAGE RATE-BTU/HR (QUAL DATA)

	<u>GROUND</u>	<u>SPACE</u>
● NON-VENTED	26.5	13.5
● VENTED	16.5	5.0

385

FLUIDS MANAGEMENT TECHNOLOGY	PROPULSION AND POWER DIVISION	
	JOHN M. MCGEE	6/23/82

FUTURE MISSIONS

- SHUTTLE/EXPENDABLE ORBITAL TRANSFER VEHICLE (OTV)
- SHUTTLE/REUSABLE (SPACE BASED) OTV RESUPPLY OF PROPELLANTS & CONSUMABLES
- SHUTTLE/SPACE STATION RESUPPLY OF CONSUMABLES & PROPELLANT FOR OTV
- SHUTTLE/UNMANNED SATELLITE RESUPPLY OF CONSUMABLES
- SPACE STATION/UNMANNED SATELLITE RESUPPLY OF CONSUMABLES
- SPACE STATION/OTV RESUPPLY OF CONSUMABLES AND PROPELLANT
- OTV/GEO STATION RESUPPLY OF CONSUMABLES

386

ORIGINAL PAGE IS
OF POOR QUALITY

FLUIDS MANAGEMENT TECHNOLOGY

PROPULSION AND POWER DIVISION

JOHN M. MCGEE

6/23/82

ORBITER TO OTV RESUPPLY

TECHNICAL CONSIDERATIONS

- **PROPELLANT TRANSFER EFFICIENCY**
 - ▲ SUPPLY TANK WEIGHTS
 - ▲ SUPPLY TANK RESIDUALS
 - ▲ OTV FILL LOSSES
 - ▲ ORBIT STAY-TIME LOSSES

- **OPERATIONS**
 - ▲ INSULATION
 - ▲ PROPELLANT TRANSFER
 - ▲ PROPELLANT ACQUISITION

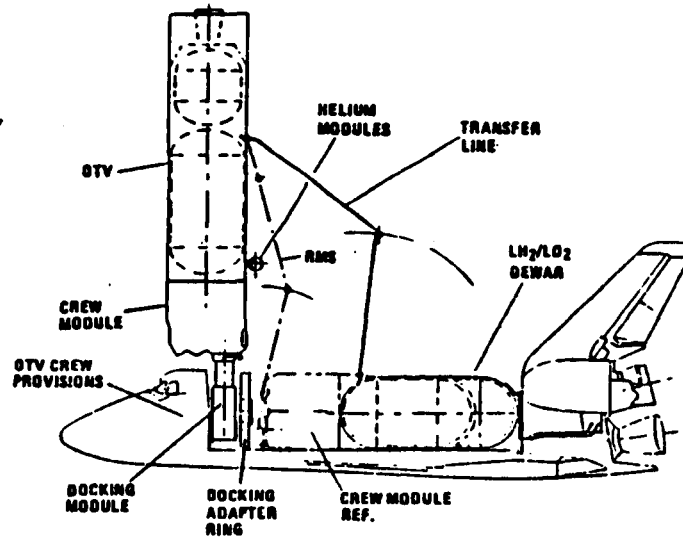

ORIGINAL PAGE IS
OF POOR QUALITY

387

FLUIDS MANAGEMENT TECHNOLOGY

PROPULSION AND POWER DIVISION

JOHN M. MCGEE

6/23/82

ROCKWELL SOC REFUELING SCHEMATIC

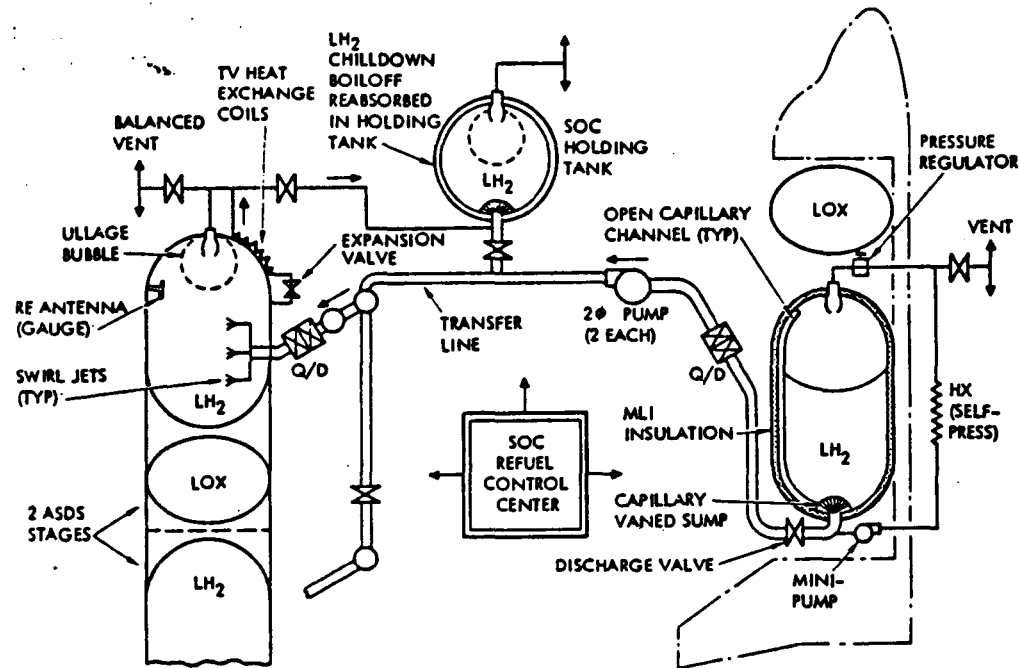

ORIGINAL PAGE IS
OF POOR QUALITY

388

FLUIDS MANAGEMENT TECHNOLOGY

PROPULSION AND POWER DIVISION

JOHN M. MCGEE

6/23/82

SPACE PROCESSING FACILITY ORBITER SERVICING

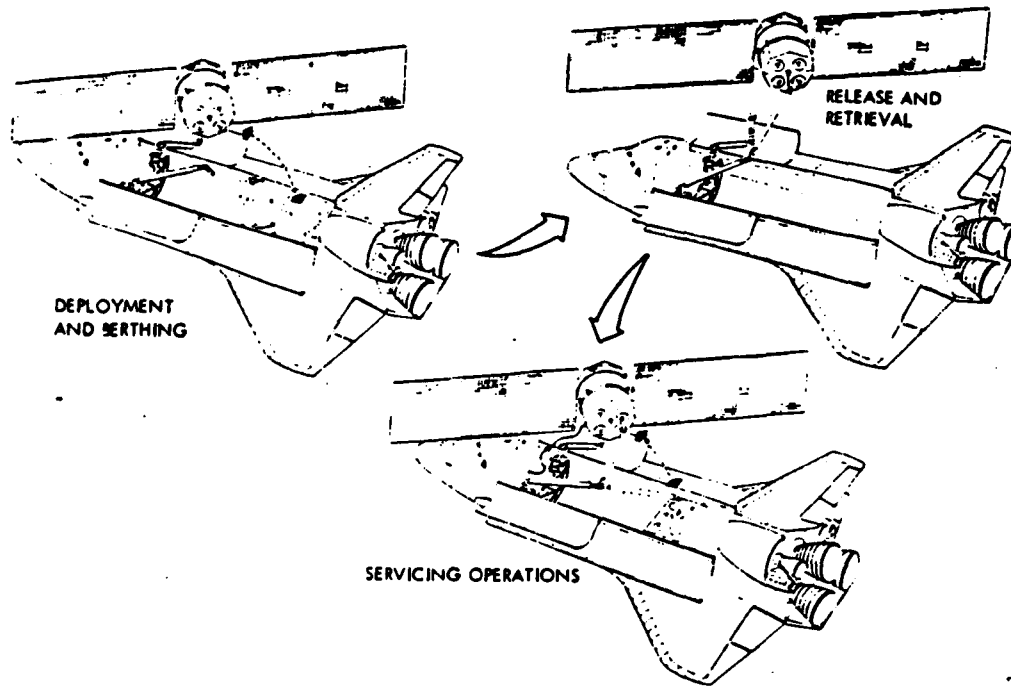

389

ORIGINAL PAGE IS
OF POOR QUALITY

FLUIDS MANAGEMENT TECHNOLOGY

PROPULSION AND POWER DIVISION

JOHN M. MCGEE

6/23/82

COMMSAT/OTV MATING & DEPLOYMENT SCENARIO

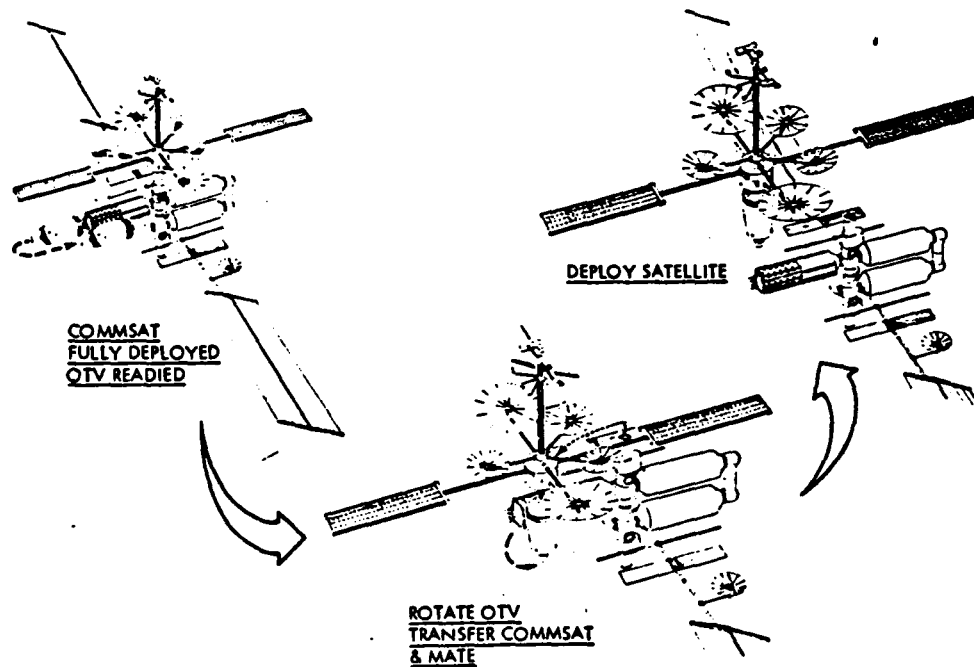

ORIGINAL PAGE IS
OF POOR QUALITY

390

FLUIDS MANAGEMENT TECHNOLOGY

PROPULSION AND POWER DIVISION

JOHN M. MCGEE

6/23/82

ORBIT TRANSFER VEHICLE (OTV)

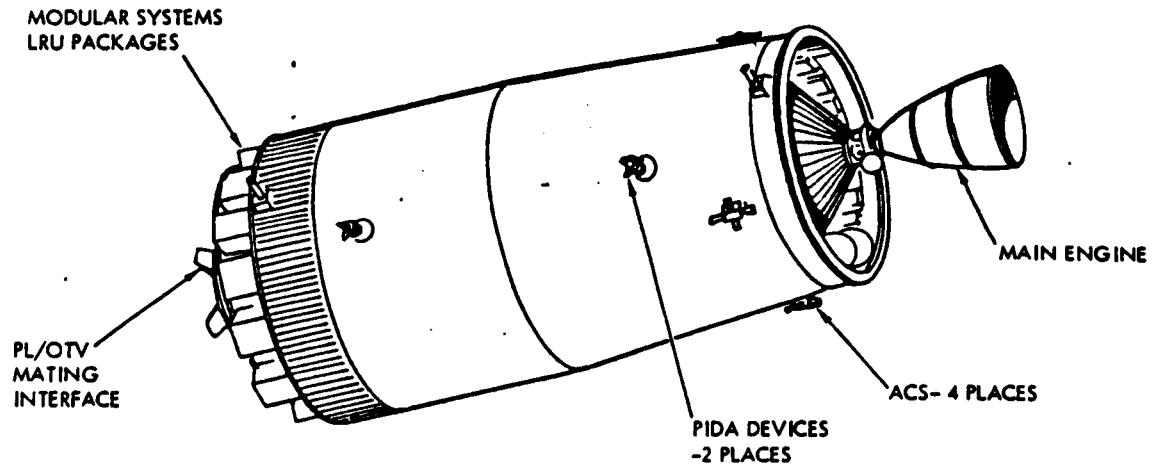

ORIGINAL PAGE IS
OF POOR QUALITY

- REFUELING OF A SPECTRUM OF PROPELLANTS- LO_2/LH_2 ; HYDRAZINE; He & GN_2
- EXTENSIVE SERVICING & MODULE EXCHANGE OPERATIONS ARE REQUIRED
- FREQUENT VISITS TO SOC

391

FLUIDS MANAGEMENT TECHNOLOGY	PROPULSION AND POWER DIVISION	
	JOHN M. MCGEE	6/23/82

FLUID MANAGEMENT REQUIREMENTS FOR
NEW TECHNOLOGY

- SHUTTLE EXTERNAL TANK (ET) PROPELLANT SCAVENGING (A PRIMARY SOURCE OF SUBCRITICAL CRYOGENICS)
- ON-ORBIT TRANSFER OF SUBCRITICAL CRYOGENICS AND HYPERGOLICS
- LIQUID PHASE ACQUISITION FOR PROPULSION (CRYOGENIC)
- SUBCRITICAL CRYOGENIC GAS DELIVERY
- LONG TERM STORAGE
- QUANTITY, QUALITY, AND FLOW RATE MEASUREMENT

ORIGINAL PAGE IS
OF POOR QUALITY

392

FLUIDS MANAGEMENT TECHNOLOGY

PROPULSION AND POWER DIVISION

JOHN M. MCGEE

6/23/82

FIGURE 3.1 ET RESIDUALS RECOVERY CONCEPT

AVAILABLE RESIDUALS - lb	
FPR	5550
LH ₂	1100
ET TRAPPED	800
MPS PLUMBING	1928
TOTAL	9348 (± FPR)

NOTE:
UP TO 61,000 lb ADDITIONAL
RESIDUALS IF ORBITER
UNDERLOADED

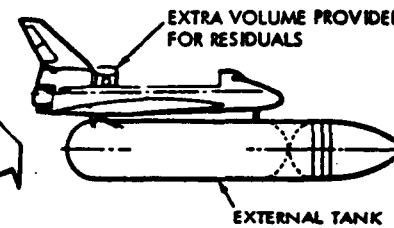

EXTRA COAST PERIOD
TO TRANSFER RESIDUALS TO
CARGO BAY TANKS

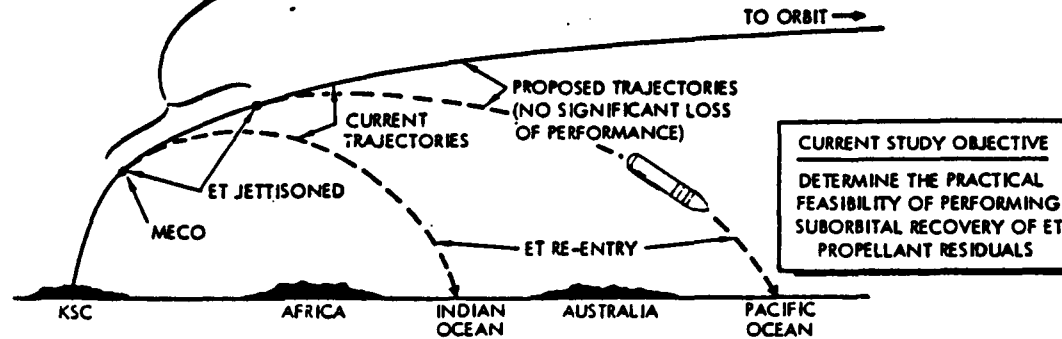

CURRENT STUDY OBJECTIVE
DETERMINE THE PRACTICAL
FEASIBILITY OF PERFORMING
SUBORBITAL RECOVERY OF ET
PROPELLANT RESIDUALS

395

ORIGINAL PAGE IS
OF POOR QUALITY

FLUIDS MANAGEMENT TECHNOLOGY

PROPULSION AND POWER DIVISION

JOHN M. MCGEE

6/23/82

FLUIDS MANAGEMENT METHODS/TECHNIQUES

- BULK FLUID TRANSFERS FOR SUBSEQUENT USE IN CONSUMING SYSTEMS
 - ET SCAVENGING - RCS OR OMS SETTLING (10^{-3} TO $10^{-2}G$)
 - ON-ORBIT TRANSFERS/LEO - (10^{-5} TO $10^{-4}G$)
 - FULL VESSEL/EMPTY VESSEL EXCHANGE
 - VESSELS ONLY
 - AS PART OF WHOLE STAGES OR MODULES
 - VESSEL TO VESSEL FLOW
 - DYNAMIC TECHNIQUES
 - VEHICLE MANEUVER
 - INTERNAL DEVICE
 - PASSIVE TECHNIQUE
 - DIAPHRAGM/BELLOWS
 - CAPILLARY CHANNELS OR VANES
 - CAPILLARY SCREENS

ORIGINAL PAGE IS
OF POOR QUALITY

394

FLUIDS MANAGEMENT TECHNOLOGY

PROPULSION AND POWER DIVISION

JOHN M. MCGEE

6/23/82

MECHANICALLY INDUCED SETTLING TECHNOLOGY
(MIST)

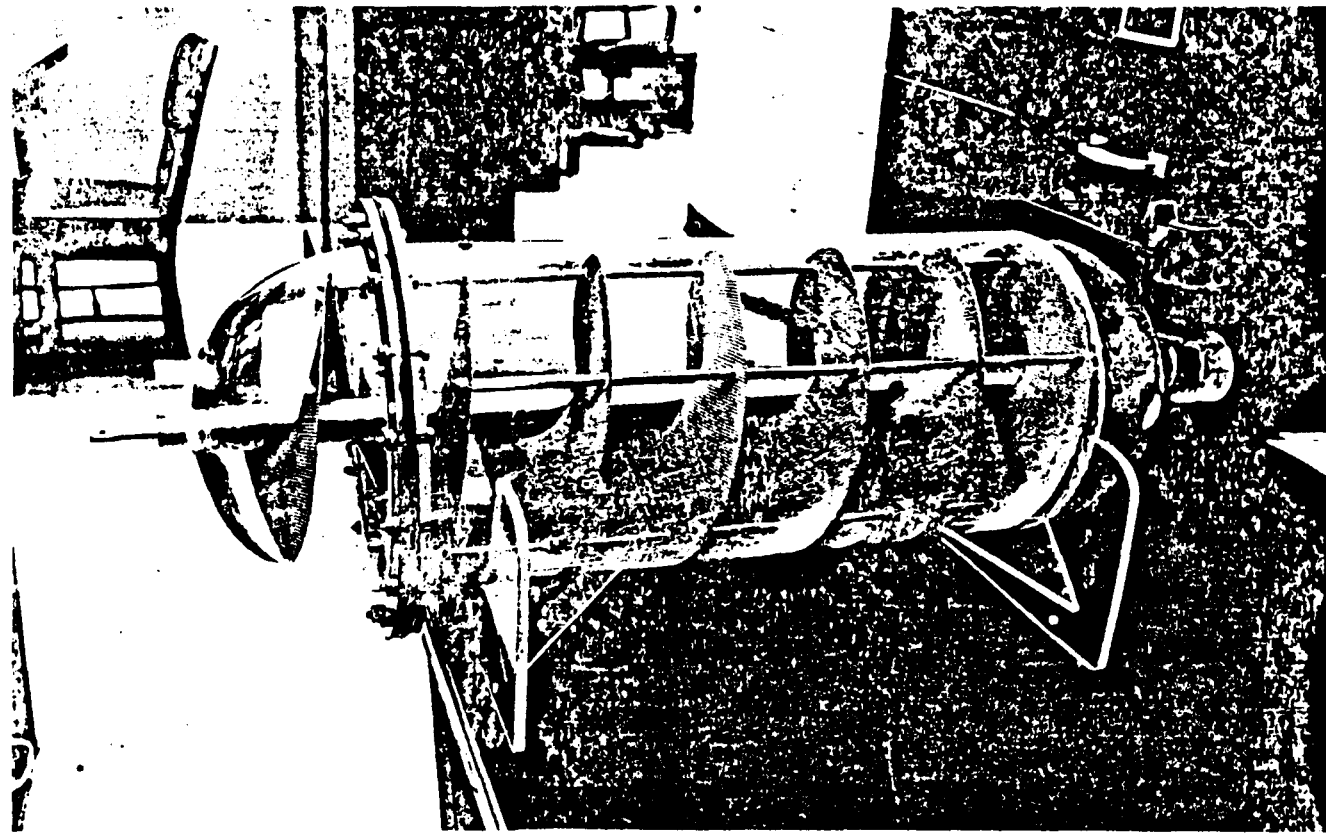

395

ORIGINAL PAGE IS
OF POOR QUALITY

FLUIDS MANAGEMENT TECHNOLOGY

PROPULSION AND POWER DIVISION

JOHN M. MCGEE

6/23/82

LH₂ START BASKET

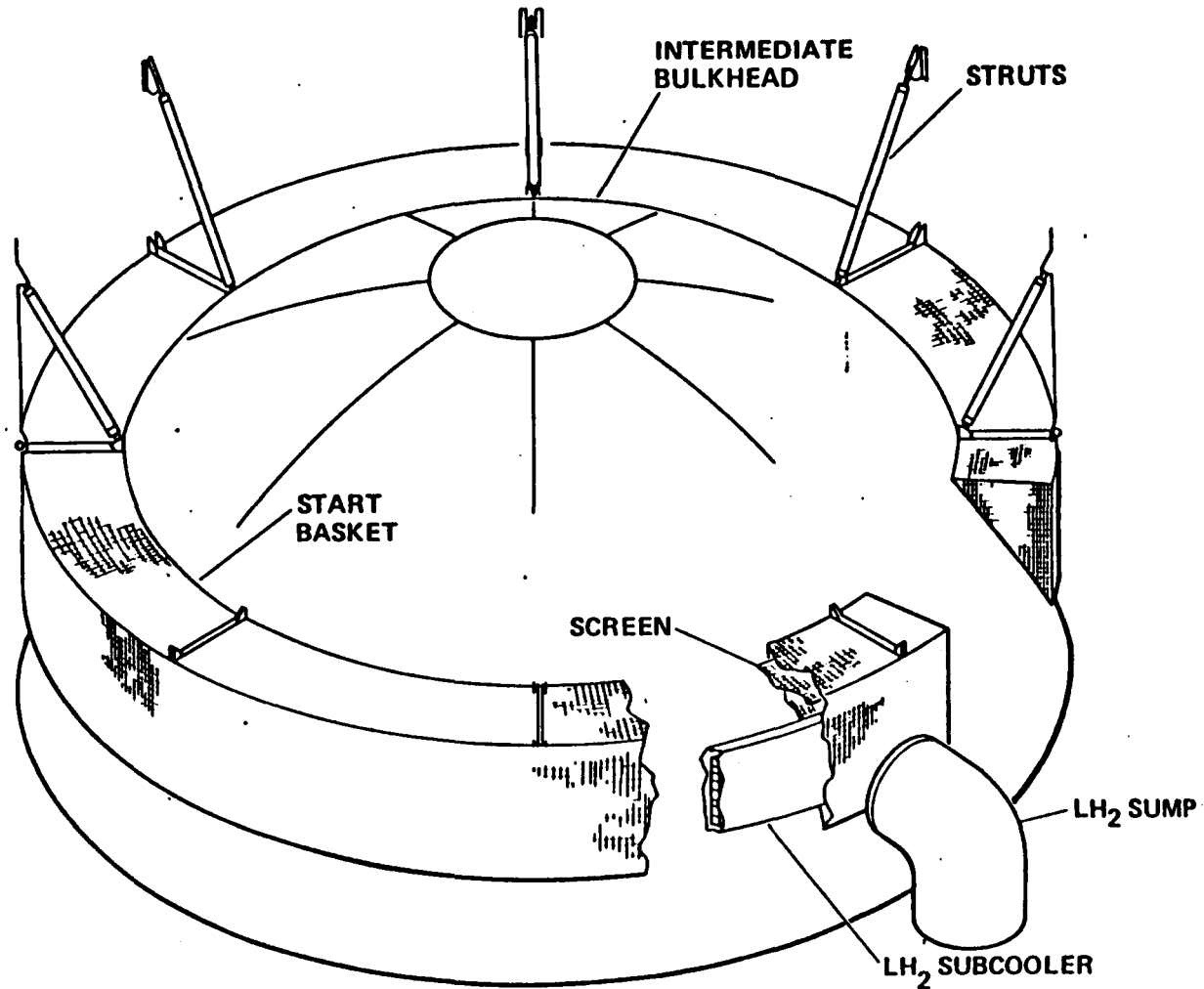

ORIGINAL PAGE IS
OF POOR QUALITY

396



FLUIDS MANAGEMENT TECHNOLOGY

PROPULSION AND POWER DIVISION

JOHN M. MCGEE

6/23/82

FLUIDS MANAGEMENT METHODS/TECHNIQUES (CONT'D)

- VESSEL OUTFLOW TO CONSUMING SYSTEMS
 - SUPERCRITICAL CRYOGENICS
 - LIQUID DELIVERY FROM TWO PHASE FLUID
 - DYNAMIC TECHNIQUES
INTERNAL DEVICES
 - PASSIVE TECHNIQUES
DIAPHRAGMS/BELLOWS
CAPILLARY CHANNELS OR VANES
CAPILLARY SCREENS
 - GAS DELIVERY FROM SUBCRITICAL CRYOGENIC FLUIDS
 - JOULE-THOMPSON, VAPOR COOLED SHIELD

ORIGINAL PAGE IS
OF POOR QUALITY

397

FLUIDS MANAGEMENT TECHNOLOGY

PROPULSION AND POWER DIVISION

JOHN M. MCGEE

6/23/82

ROCKWELL TVS CONCEPT

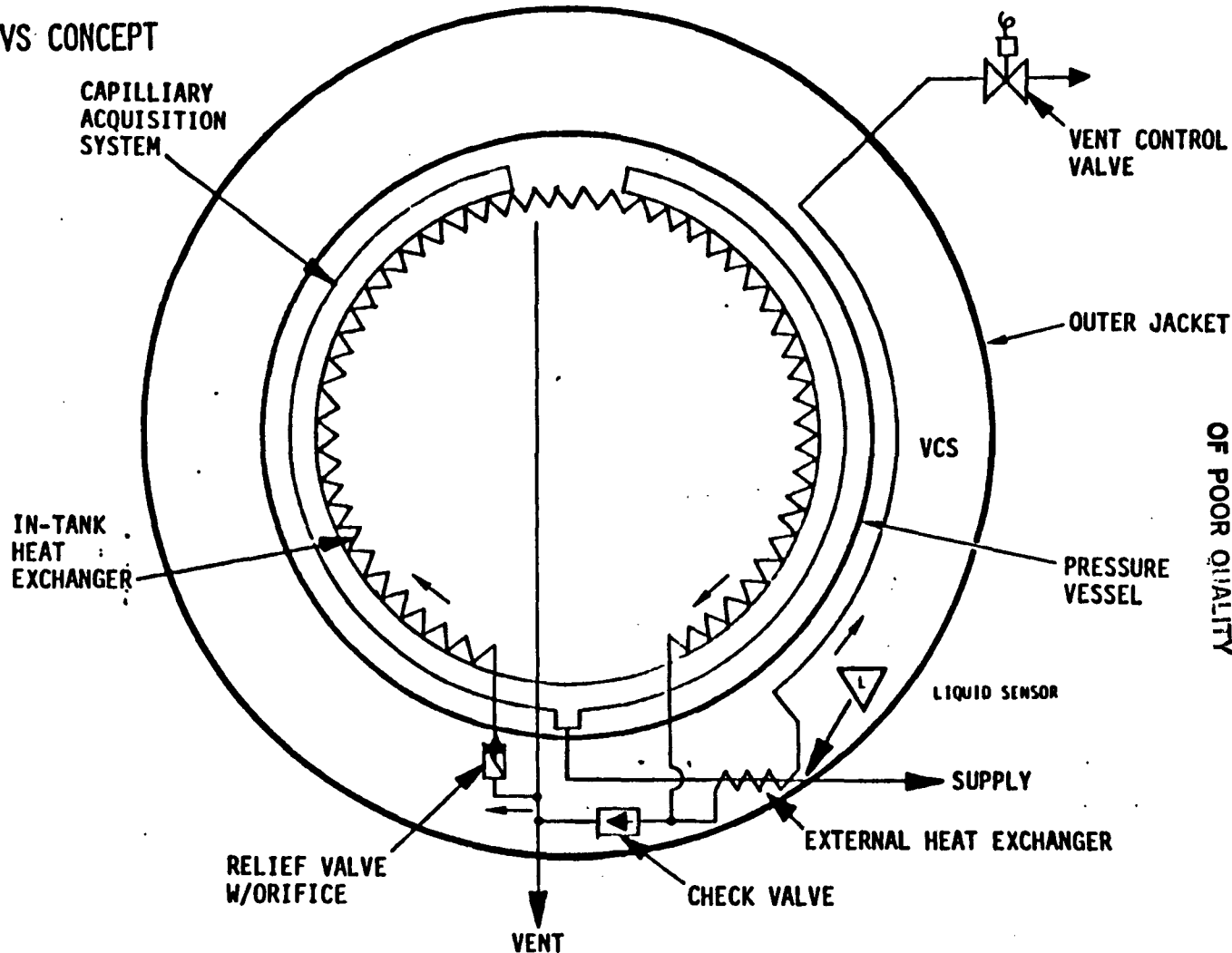

398

ORIGINAL PAGE IS
OF POOR QUALITY

FLUIDS MANAGEMENT TECHNOLOGY

PROPULSION AND POWER DIVISION

JOHN M. MCGEE

6/23/82

FLUIDS MANAGEMENT METHODS/TECHNIQUES (CONT'D)

- LONG TERM STORAGE OF CRYOGENICS
 - SINGLE WALL, ISOLATION MOUNTS, MULTILAYER INSULATION, VAPOR COOLED SHIELDS
 - DEWARS
 - ACTIVE REFRIGERATION
 - BOILOFF PREVENTION
 - TRANSFER BOILOFF RECOVERY
 - SUBCOOLING OF PROPELLANTS
- QUANTITY MEASUREMENT
 - RADIO FREQUENCY
 - NUCLEONIC
 - ACOUSTIC CAVITY/ULTRASONIC
 - MECHANICAL SETTLING/LEVEL SENSORS
 - ACCUMULATIVE FLOW
 - PRESSURE, VOLUME, TEMPERATURE

ORIGINAL PAGE IS
OF POOR QUALITY

399

FLUIDS MANAGEMENT TECHNOLOGY

PROPULSION AND POWER DIVISION

JOHN M. MCGEE

6/23/82

BASELINE CRYO PROPELLANT LOSS MODEL (MOTV/SOC/ORBITER)

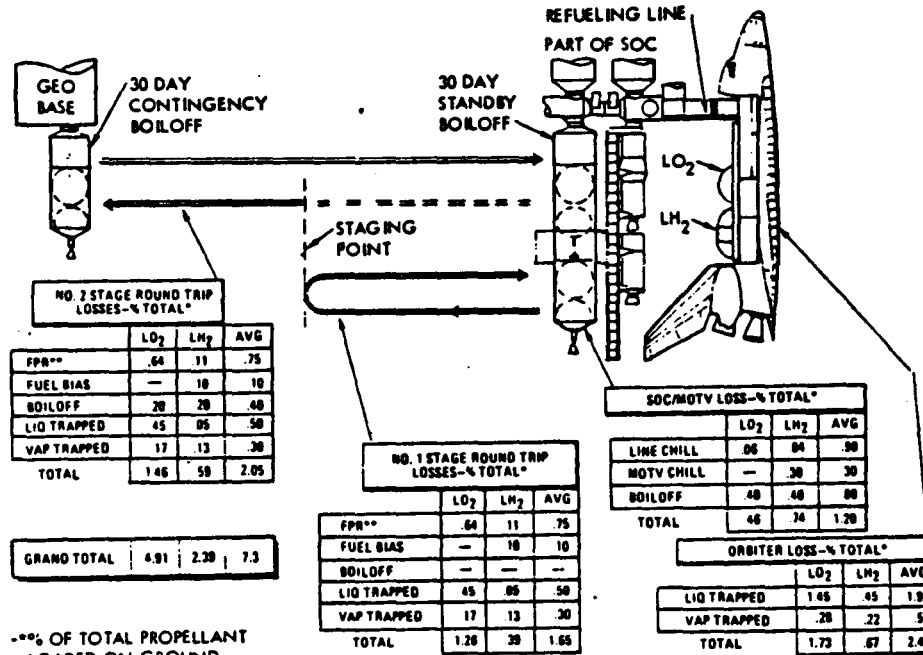

NO. 2 STAGE ROUND TRIP LOSSES-% TOTAL*

	LO ₂	LH ₂	AVG
FPR**	.64	.11	.75
FUEL BIAS	—	10	10
BOILOFF	20	20	40
LIQ TRAPPED	45	05	50
VAP TRAPPED	17	13	30
TOTAL	1.46	.58	2.05

GRAND TOTAL

	LO ₂	LH ₂	AVG
	4.91	2.39	7.3

NO. 1 STAGE ROUND TRIP LOSSES-% TOTAL*

	LO ₂	LH ₂	AVG
FPR**	.64	.11	.75
FUEL BIAS	—	10	10
BOILOFF	—	—	—
LIQ TRAPPED	45	05	50
VAP TRAPPED	17	13	30
TOTAL	1.26	.39	1.65

SOC/MOTV LOSS-% TOTAL*

	LO ₂	LH ₂	AVG
LINE CHILL	06	04	30
MOTV CHILL	—	30	30
BOILOFF	48	40	80
TOTAL	46	74	1.20

ORBITER LOSS-% TOTAL*

	LO ₂	LH ₂	AVG
LIQ TRAPPED	1.46	.45	1.9
VAP TRAPPED	.28	.22	.5
TOTAL	1.73	.67	2.4

*-% OF TOTAL PROPELLANT LOADED ON GROUND
 **FLIGHT PERFORMANCE RESERVE

ORIGINAL PAGE IS
OF POOR QUALITY

400

FLUIDS MANAGEMENT TECHNOLOGY

PROPULSION AND POWER DIVISION

JOHN M. MCGEE

6/23/82

CRYOGENIC FLUID STORAGE ACTIVE THERMAL CONTROL CONCEPTS

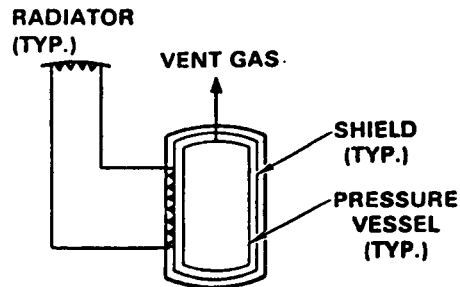

COOLED SHIELD

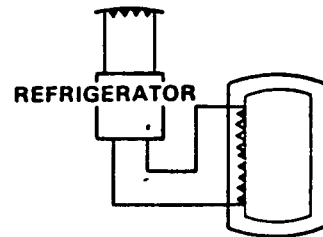
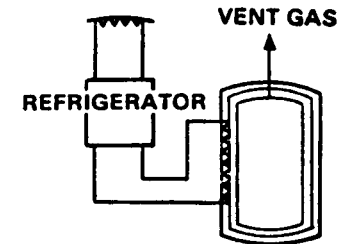

COOLED PRESSURE VESSEL

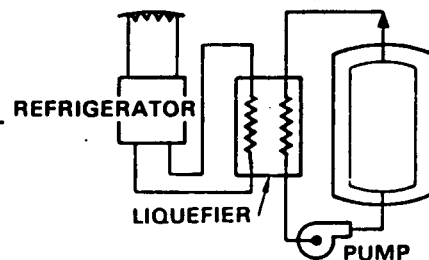
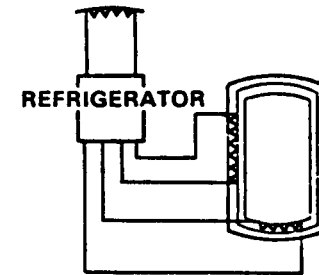

RELIQUEFACTION

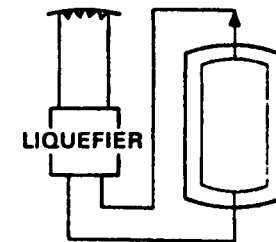

ORIGINAL PAGE IS
OF POOR QUALITY

401

FLUIDS MANAGEMENT TECHNOLOGY	PROPULSION AND POWER DIVISION	
	JOHN M. MCGEE	6/23/82

FLUIDS MANAGEMENT METHODS/TECHNIQUES (CONT'D)

- QUALITY MEASUREMENT
 - LIQUID SENSORS - VAPORS DETECTION ONLY
 - MASS FLOW METER
- FLOW MEASUREMENT
 - MASS FLOW METER
 - STANDARD TECHNIQUES

ORIGINAL PAGE IS
OF POOR QUALITY

402

FLUIDS MANAGEMENT TECHNOLOGY	PROPULSION AND POWER DIVISION	
	JOHN M. MCGEE	6/23/82

NASA FUNDED PROGRAMS

- CRYOGENIC FLUID MANAGEMENT FACILITY - ORBITER PAYLOAD BAY EXPERIMENT (LeRC)
 - LIQUID HYDROGEN ON-ORBIT TRANSFER
 - SUPPLY DEWAR
 - SINGLE WALL RECEIVER (OTV SUBSCALE)
 - QUANTITY, QUALITY, FLOW METER TESTBED
- QUANTITY METER DEVELOPMENT (JSC)
- OTV TANKAGE DEVELOPMENT (MSFC)
- MECHANICALLY INDUCED SETTLING TECHNOLOGY (MIST-JSC)

FUTURE PROGRAMS

- ET SCAVENGING TECHNOLOGY
- MASS FLOW METER DEVELOPMENT

ORIGINAL PAGE IS
OF POOR QUALITY

403

FLUIDS MANAGEMENT TECHNOLOGY

PROPULSION AND POWER DIVISION

JOHN M. MCGEE

6/23/82

OHTE PAYLOAD INSTALLATION

OHTE WT (W/LH₂) = 2460 LB

ORIGINAL PAGE IS
OF POOR QUALITY

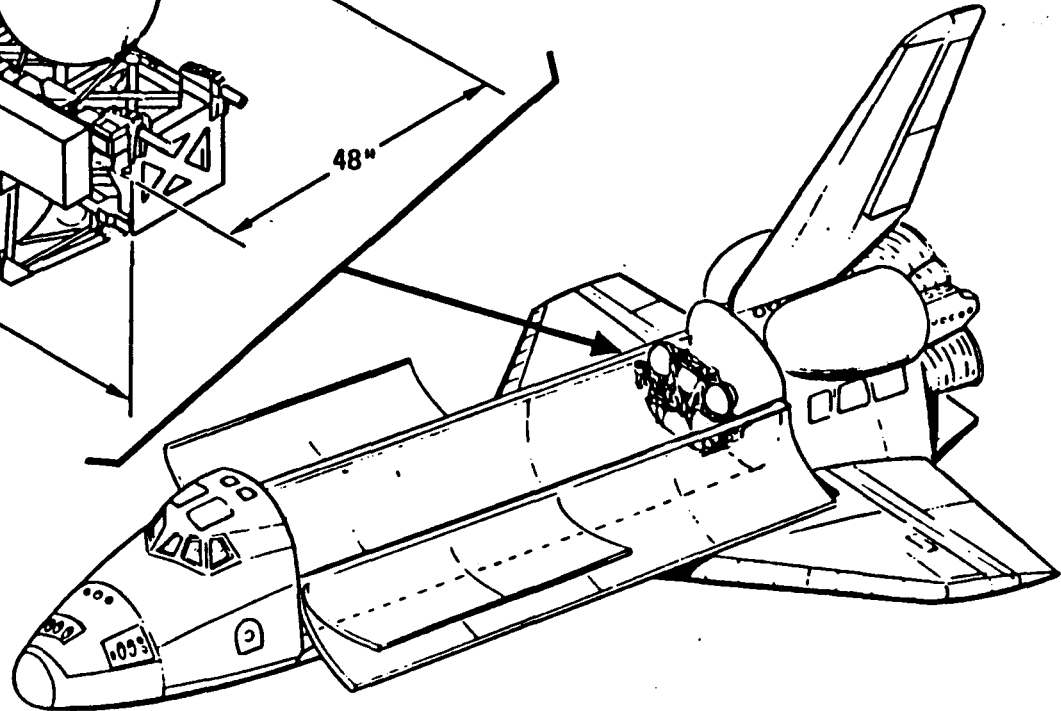
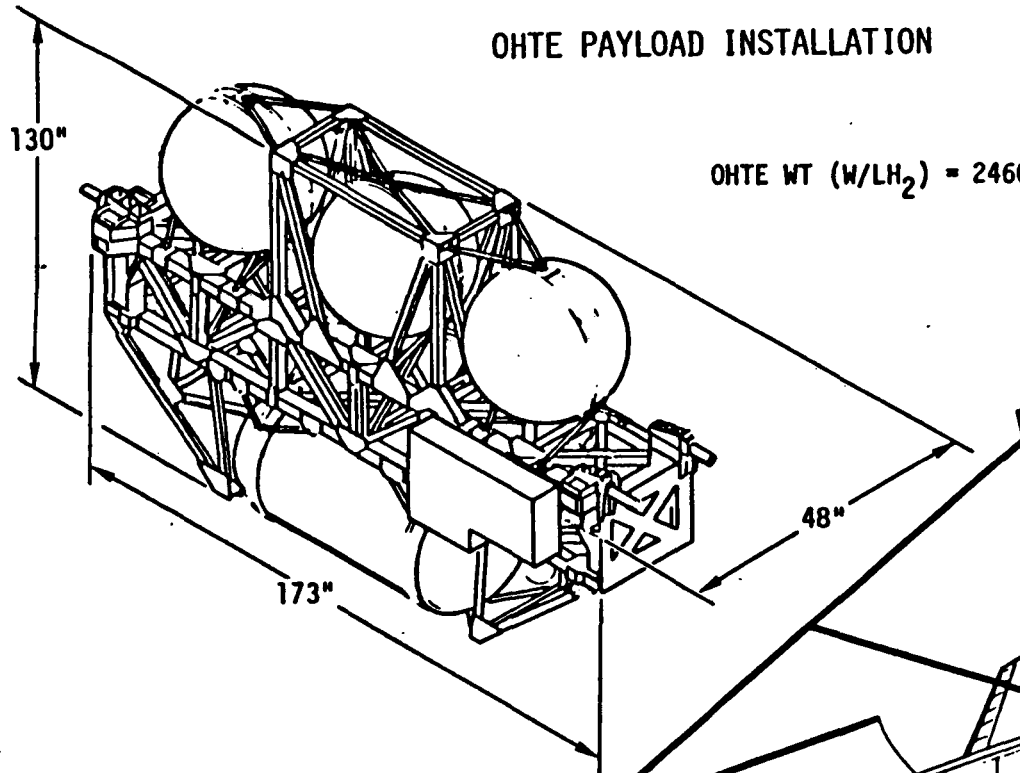

404

FLUIDS MANAGEMENT TECHNOLOGY

PROPULSION AND POWER DIVISION

JOHN M. MCGEE

6/23/82

CFMF PHASE II PALLET

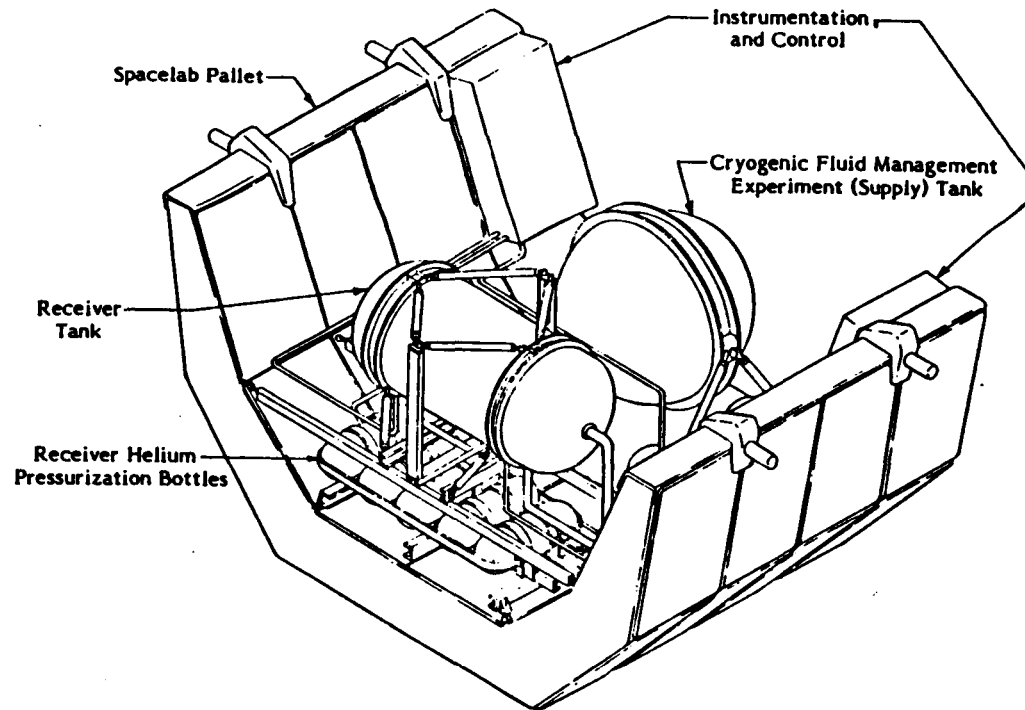

405

ORIGINAL PAGE IS
OF POOR QUALITY

6/23/82

11196
1183

ORIGINAL PAGE IS
OF POOR QUALITY

ORBITER OMS AND RCS TECHNOLOGY

R. A. BOUDREAU
ROCKWELL INTERNATIONAL

466



ORBITAL MANEUVER SUBSYSTEM

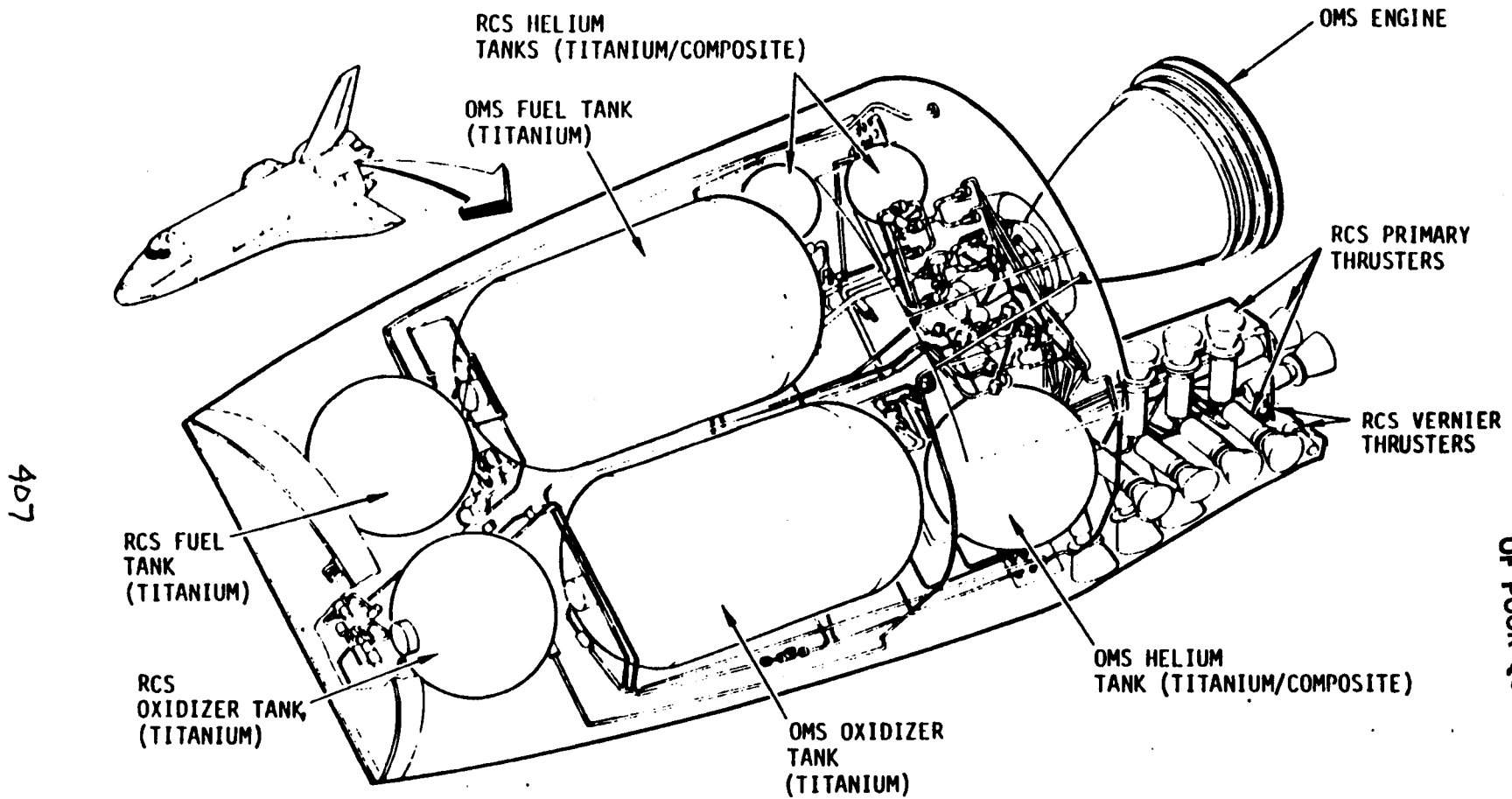

ORIGINAL PAGE IS
OF POOR QUALITY

ORBITER OMS AND RCS TECHNOLOGY

INTRODUCTION

- ORBITER OMS AND RCS TANKAGE HAS BEEN HIGHLY SUCCESSFUL IN SHUTTLE FLIGHTS AS OF THIS WRITING (STS-1, 2, AND 3)

- OMS AND RCS TECHNOLOGY HAS PROVIDED A SUBSTANTIAL BASIS FOR FUTURE USES OF STORABLE PROPELLANTS
 - UNDERSTANDING OF FLUID MECHANICS AND SCREEN FUNCTION
 - SYNTHESIS OF LIGHT WEIGHT SUPPORT AND SCREEN STRUCTURES
 - TANK QUALIFICATION IN HOSTILE ENVIRONMENTS
 - SUCCESSFUL FLIGHT DEMONSTRATION OF FUNDAMENTAL MODES OF OPERATION -- TRANSLATION MANEUVERS AND REACTION CONTROL

- REMAINING TECHNOLOGY UNEXPLORED BY OMS AND RCS APPLICATIONS IS CENTERED ON ON-ORBIT PROPELLANT TRANSFER

408

ORIGINAL PAGE IS
OF POOR QUALITY



OMS PROPELLANT TANKS

409

ORIGINAL PAGE IS
OF POOR QUALITY



OMS PROPELLANT ACQUISITION SYSTEM

PURPOSE

- TO MAINTAIN PROPELLANT AT TANK OUTLET UNDER ZERO G CONDITIONS AND THEREBY ALLOW INITIAL FLOW TO START THE ENGINE; ALLOW PROPELLANT USAGE BY RCS UNDER LOW G

CHARACTERISTICS

- PROVIDE PROPELLANTS, FREE OF UNDISSOLVED PRESSURANT GAS/PROPELLANT VAPOR, TO THE OMS/RCS ENGINES
- PROVIDE CAPABILITY OF 10 OMS STARTS WITHOUT PROPELLANT SETTLING
- PROVIDE 454 KG (1000 LBS) OF PROPELLANT TO THE RCS PER TANK SET
- MAXIMUM STARTUP FLOW RATES KG/SEC (LBS/SEC)

410

	<u>NTO</u>	<u>MMH</u>
● OMS POD (1 ENGINE/FEED)	5.41 KG/SEC (11.93 LBS/SEC)	3.28 KG/SEC (7.23 LBS/SEC)
● RCS POD (7 THRUSTER/FEED)	5.87 KG/SEC (12.95 LBS/SEC)	3.68 KG/SEC (8.12 LBS/SEC)
● MINIMUM PROPELLANT (START WITHOUT RCS ULLAGE BURN)	377 KG (831 LBS)	289 KG (504 LBS)
● WEIGHT:	17.7 KG (38.9 LBS)	
● TOTAL PER VEHICLE:	4	

ORIGINAL PAGE IS
OF POOR QUALITY

LAUNCH MINUS 2 DAY REVIEW
OMS PROPELLANT TANK CONFIGURATION

SUPPLIER: MCDONNELL ASTRONAUTICS COMPANY, EAST (TANK ASSEMBLY)
AEROJET MANUFACTURING COMPANY (PRESSURE VESSEL)

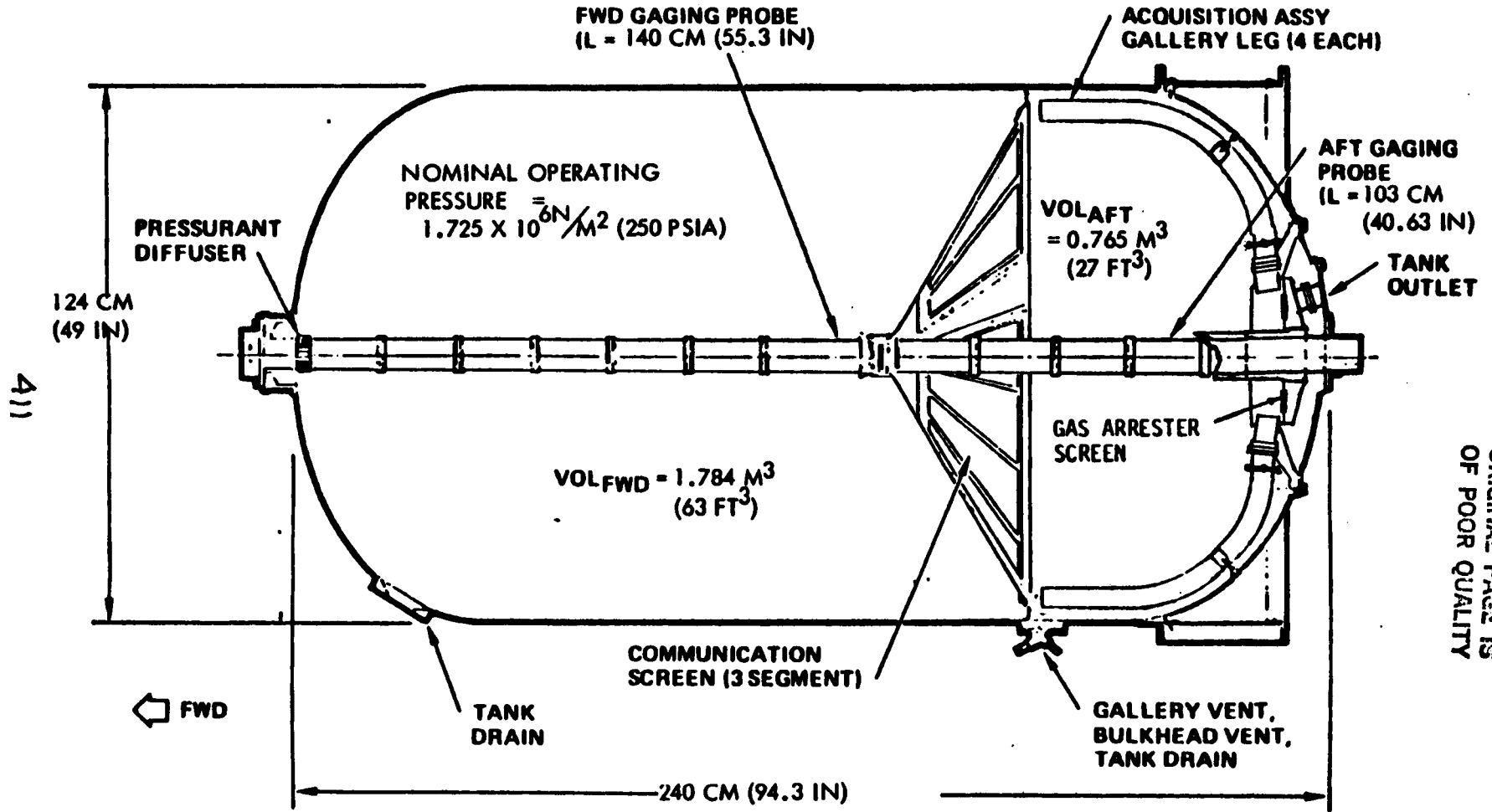

ORIGINAL PAGE IS
OF POOR QUALITY

PROPELLANT ACQUISITION SYSTEM

COMMUNICATION SCREEN: 200 X 1400
TWILLED DOUBLE DUTCH WEAVE (TDDW)

SCREEN PORE SIZE = 15μ

BUBBLE POINT = 2089 N/M^2 (.303 PSI) N_2O_4
= 3054 N/M^2 (.443 PSI) MMH

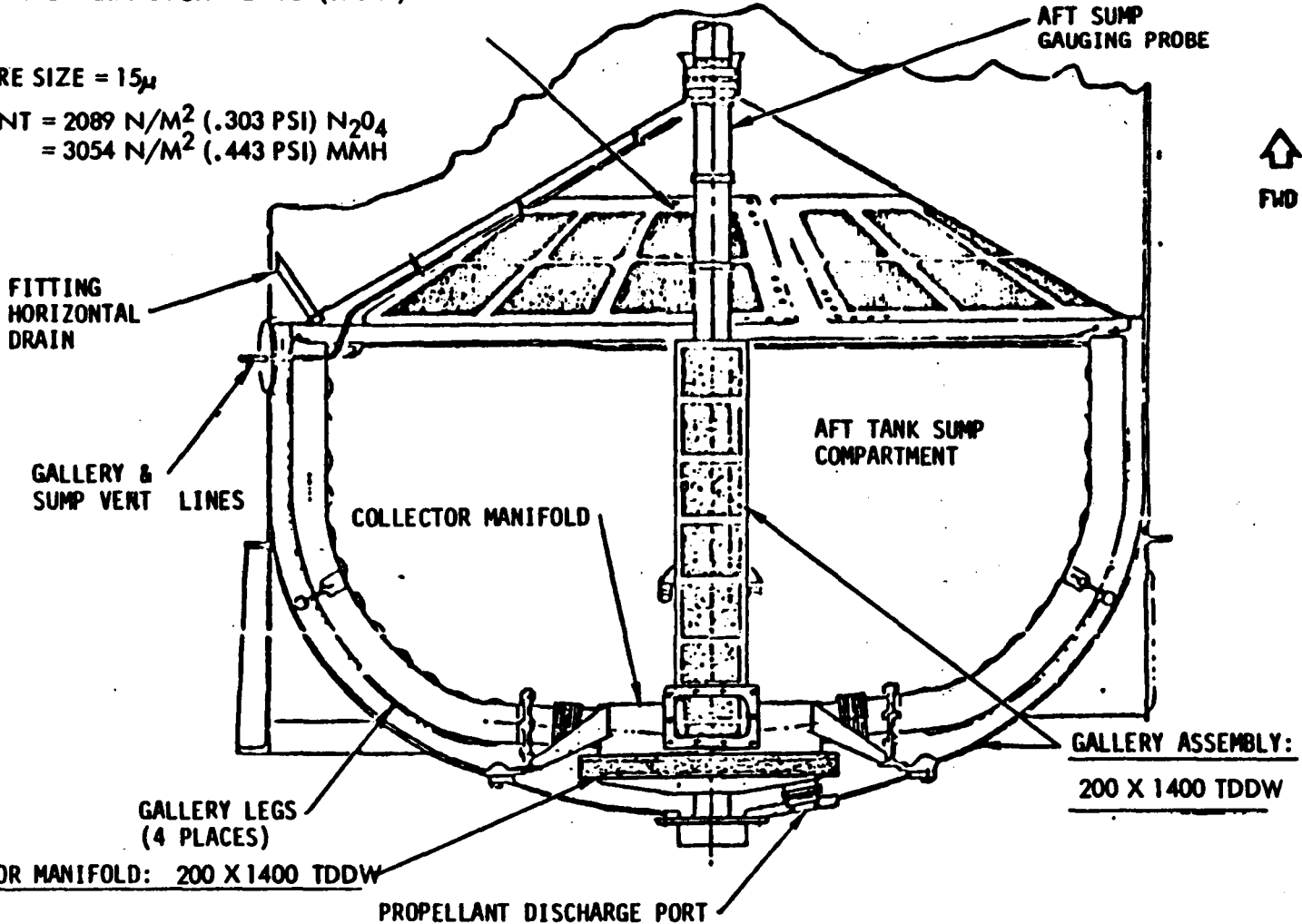

412

ORIGINAL PAGE IS
OF POOR QUALITY

COLLECTOR MANIFOLD: 200 X 1400 TDDW

GALLERY ASSEMBLY:
200 X 1400 TDDW



OMS PROPELLANT ACQUISITION SYSTEM
OPERATING MODES

BOOST

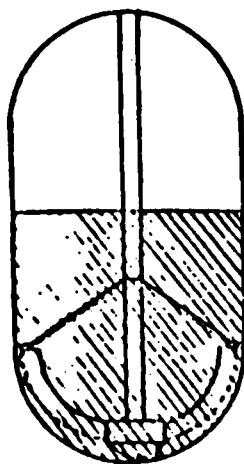

RCS FEED

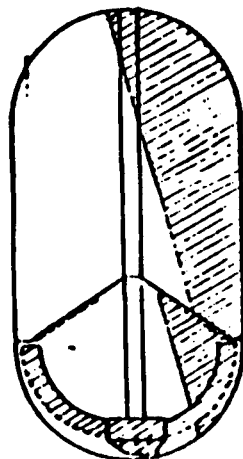

OMS START

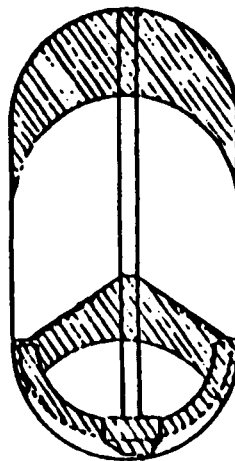

OMS BURN

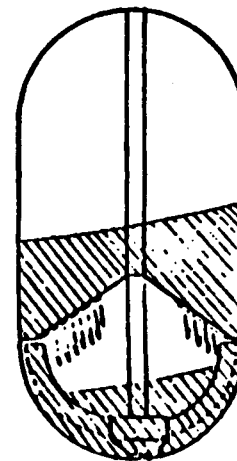

ORIGINAL PAGE IS
OF POOR QUALITY

413



**OMS PROPELLANT TANKS
ACQUISITION SYSTEM DEVELOPMENT**

- **KEY PROBLEMS ENCOUNTERED**
 - **FAILURE OF PLAIN DUTCH SQUARE WEAVE SCREEN DURING VIBRATION TESTING**
 - **COINING AT EDGE OF SCREEN PANEL REDUCED WIRE CROSS-SECTION AND THEREFORE FATIGUE LIFE**
 - **EXCESSIVE NUMBER OF IN PROCESS REPAIRS**
 - **STRESS RELIEF OF TI WELDS OVER-STRESSED SCREENS**
- **SOLUTIONS**
 - **ELIMINATED COINING AND EMPLOYED STRONGER TDDW**
 - **REVISED FABRICATION PROCESS TO ELIMINATE STRESS RELIEF AFTER SCREEN PANEL INSTALLATION**

414

ORIGINAL PAGE IS
OF POOR QUALITY



**EFFECT OF BULKHEAD SCREEN FAILURE
TRANSLATION MANEUVERS**

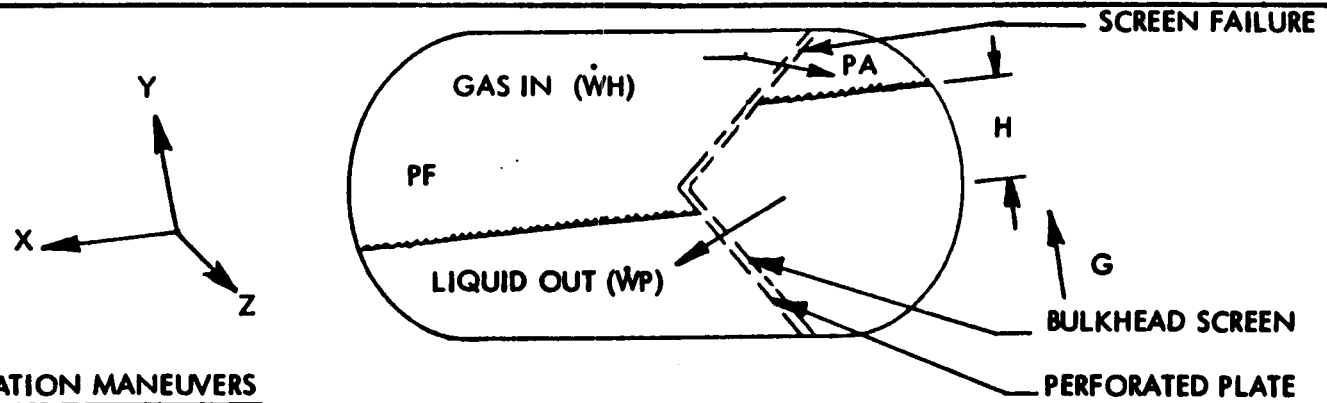

● Y, Z TRANSLATION MANEUVERS

- A HEAD DIFFERENCE (H) IS ESTABLISHED BETWEEN THE FORWARD AND AFT TANK COMPARTMENTS DEPENDING ON THE RELATIVE QUANTITIES
- LIQUID CAN FLOW OUT OF THE AFT COMPARTMENT ONLY AS FAST AS ITS VOLUME IS REPLACED BY IN FLOW OF HELIUM
- HELIUM IN FLOW IS A FUNCTION OF THE EFFECTIVE FLOW AREA AND PRESSURE DIFFERENTIAL
- MAXIMUM ΔP IS 2068 N/M² (0.3 PSI) AND DECREASES AS THE PROPELLANT IS TRANSFERRED. THEREFORE, PROPELLANT IS TRANSFERRED AT A RELATIVELY SLOW RATE, EVEN WITH SIGNIFICANT SCREEN FAILURES

● -X TRANSLATION MANEUVERS

- HEAD EFFECTS EVEN LESS SEVERE

● RESULTING EFFECTS

- CREDIBLE SCREEN FAILURES WILL RESULT IN LITTLE PROPELLANT TRANSFER
- ENGINE RESTARTS NOT AFFECTED

415

ORIGINAL PAGE IS
OF POOR QUALITY

EFFECT OF BAND SCREEN FAILURE

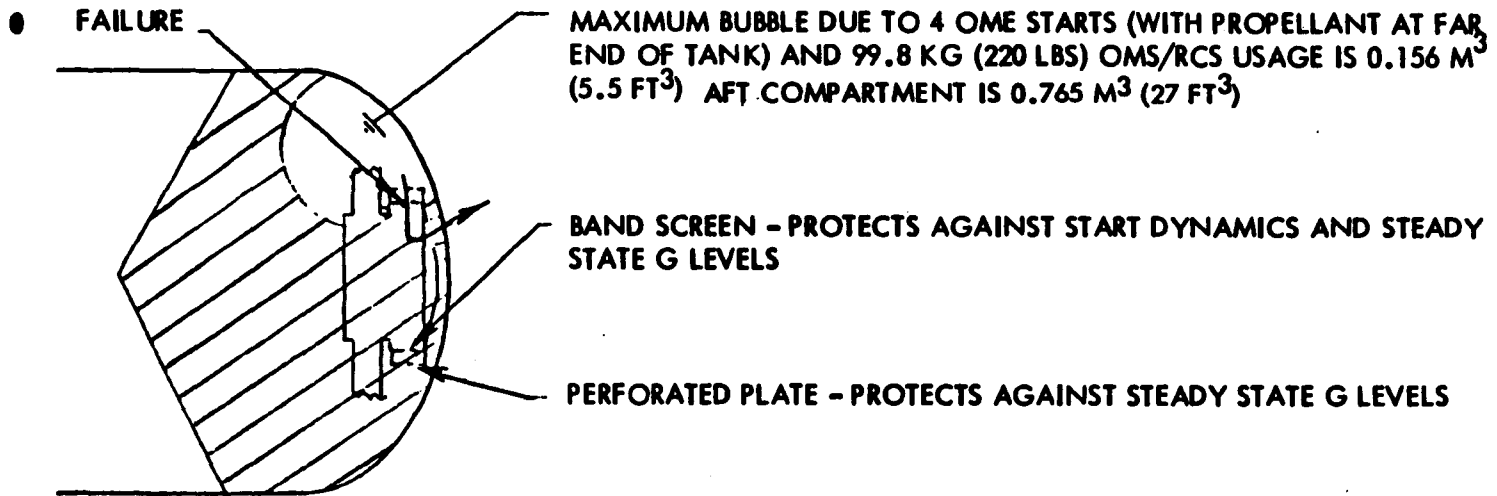

416

- EFFECT OF FAILURE - MINOR
 - IF BUBBLE IS ADJACENT TO FAILED AREA DURING PROPELLANT SLOSH, SOME BUBBLES WILL BE PULLED IN TO FEED SYSTEM DURING INITIAL START TRANSIENTS
 - MAY RESULT IN A SHORT PERIOD (≈ 0.5 SEC) OF 2 PHASE FLOW ACCEPTABLE TO OMS ENGINE

ORIGINAL PAGE IS
OF POOR QUALITY

EFFECT OF GAS ARRESTOR SCREEN FAILURE

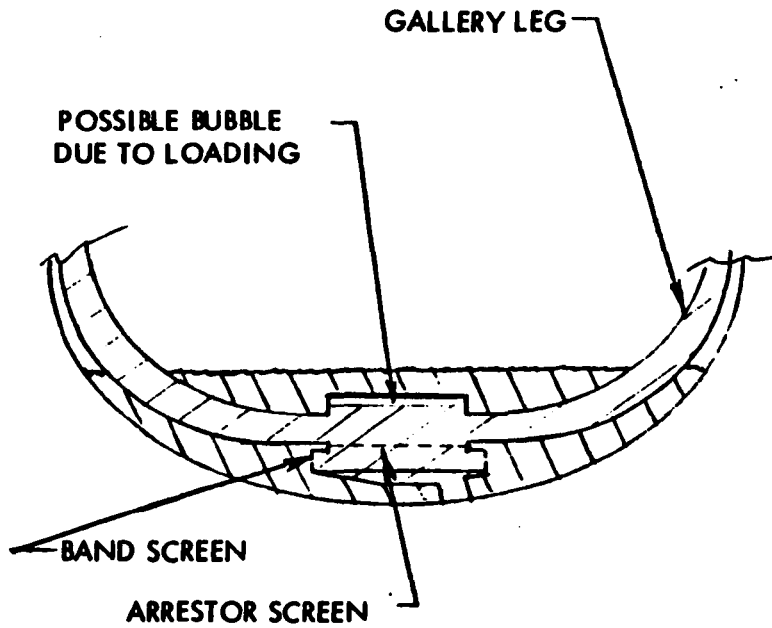

- **FUNCTION**
 - **KEEPS BUBBLE IN GALLERY LEG SECTION**
 - **GALLERY SCREENS BREAK DOWN AS TANK EMPTIES**
 - **ARRESTOR SCREEN PREVENTS GAS FROM ENTERING SYSTEM UNTIL BAND SCREEN UNCOVERED**

- **EFFECT OF FAILURE - MINOR**
 - **SYSTEM HAS BEEN QUALIFIED FOR BUBBLE SIZES LARGER THAN THOSE EXPECTED FROM LOADING**
 - **EXPULSION EFFICIENCY DEGRADED BY 1%**

417

ORIGINAL PAGE IS
OF POOR QUALITY

OMS ACQUISITION SYSTEM
VERIFICATION HISTORY

SCREEN PANEL TESTS

BUBBLE PT., WICKING/DEWICKING, FLOW Δ P, COMPATIBILITY
STAINLESS STEEL SCREEN/TI FOIL WELD, REDUCED B.P. WITH N₂O₄
SCREEN REPAIR TECHNIQUE

4/74 - 7/76

ACQUISITION ASSEMBLY, REDUCED SCALE

SETTLING DYN., FLUID CONTAINMENT W/OUTFLOW

8/75 - 4/76

ACQUISITION ASSEMBLY, FULL SCALE, SIM TANK

SYSTEM PERFORMANCE, SCREEN CONTAINMENT WITH VIB.

FLOW TRANSIENT GAS INGESTION

KC-135 LOW-G TESTS

10/75 - 4/77 (GRD)

4/77 - 8/77 (FLT)

ONE-HALF SCALE TANK, KC-135 LOW-G TESTS

3/76 - 7/76

TANK QUAL (TANK #2)

ACCEL, SHOCK, TRANSIENT, RANDOM VIB.

4/78 - 7/79

6 MISSION SHOCK/VIB TANK TESTS

7/79 - 10/79

100 MISSION SHOCK/VIB TANK TESTS

10/79 - 5/80

AFA 26 ACOUSTIC FATIGUE TESTS

4/80 - 7/81

418

ORIGINAL PAGE IS
OF POOR QUALITY.



FLIGHT USAGE OF OMS PROPELLANT

	PROPELLANT QUANTITY (OX + FU)											
	STS-1				STS-2				STS-3			
	L POD		R POD		L POD		R POD		L POD		R POD	
	KG	LB	KG	LB	KG	LB	KG	LB	KG	LB	KG	LB
PROPELLANT LOADED (IN TANKS)	3876	8546	4258	9388	3911	8622	4201	9263	4018	8858	3999	8818
PROPELLANT USED BY OMS												
OMS-1 BURN	759	1674	751	1655	681	1501	680	1499	742	1635	745	1643
OMS-2 BURN	660	1455	649	1431	611	1346	611	1346	767	1692	771	1700
OMS-3 BURN	240	530	-	-	-	-	-	-	-	-	-	-
OMS-3A BURN	-	-	-	-	108	238	-	-	} 135	} 298	-	-
OMS-3B BURN	-	-	-	-	216	476	-	-			-	-
OMS-4 BURN	-	-	281	619	186	410	152	335	-	-	-	-
DEORBIT	1362	3002	1338	2950	1507	3322	1508	3326	1280	2822	1287	2838
OMS PROPELLANT USED BY RCS	328	723	231	510	19	42	79	174	539	1188	507	1117
TOTAL USED	3349	7384	3250	7165	3328	7335	3030	6690	3463	7635	3310	7298
RESIDUAL	527	1162	1008	2223	583	1287	1171	2573	555	1223	689	1520

419

ORIGINAL PRICE IS
OF POOR QUALITY

TOTAL PROPELLANT USED FROM
LEFT POD TANKS
RIGHT POD TANKS

10,140 Kg (22,354 LB)
9,595 Kg (21,153 LB)

OMS PROPELLANT TANK
CERTIFICATION STATUS

- DEVELOPMENT AND QUALIFICATION PROGRAMS HAVE BEEN SUCCESSFULLY COMPLETED

- CERTIFICATION COMPLETED FOR PERFORMANCE, STRUCTURAL INTEGRITY, LIFE, AND SERVICABILITY FOR ACQUISITION SYSTEM AND PRESSURE VESSEL

- FURTHER ANALYSIS REQUIRED FOR TANK SKIRT FATIGUE LIFE PENDING DEFINITION OF LOAD SPECTRUM

420

ORIGINAL PAGE IS
OF POOR QUALITY



RCS PROPELLANT TANKS

42)



RCS TANK FUNCTION AND OPERATIONAL REQUIREMENTS

SERVICING

- FILL TANKS WHILE INSTALLED IN ORBITER ON LAUNCH PAD
 - PROVIDE GAS ULLAGE FOR THERMAL EXCURSIONS
- PROVIDE CAPABILITY TO LAUNCH OFF LOADED
 - FRCS TO 59% OF CAPACITY
 - ARCS TO 65% OF CAPACITY

BOOST REQUIREMENT

- WITHSTAND 100 MISSIONS OF BOOST RANDOM VIBRATION AND LIFTOFF TWANG
- ARCS TANK PROPELLANT BURN-OFF TO 65% DURING POWERED BOOST PHASE

RCS CONTROL OPERATION

- PROVIDE GAS FREE PROPELLANT DURING ANY COMBINATION OF THRUSTER STEADY STATE OR PULSE OPERATION DURING EXPOSURE TO OMNIDIRECTIONAL ACCELERATION FIELDS
- MATED COAST/EXTERNAL TANK SEPARATION
 - NORMAL MISSION 2.8 L/SEC (45 GPM)
 - RETURN TO LAUNCH SITE - 3.4 L/SEC (54 GPM) FRCS AND 4.0 L/SEC (63 GPM) ARCS
- ON-ORBIT
 - FRCS - 2.8 L/SEC (45 GPM) - 92% EXPULSION EFFICIENCY
 - ARCS - 4.0 L/SEC (63 GPM) - 68% EXPULSION EFFICIENCY
- ENTRY - ARCS ONLY
 - LOW G - 2.8 L/SEC (45 GPM) TO 72% EXPULSION
 - LOW G - 2.3 L/SEC (36 GPM) TO 76% EXPULSION
 - HIGH G - 2.3 L/SEC (36 GPM) TO 98% EXPULSION EFFICIENCY

422

ORIGINAL PAGE IS
OF POOR QUALITY

FORWARD REACTION CONTROL SYSTEM PROPELLANT TANK

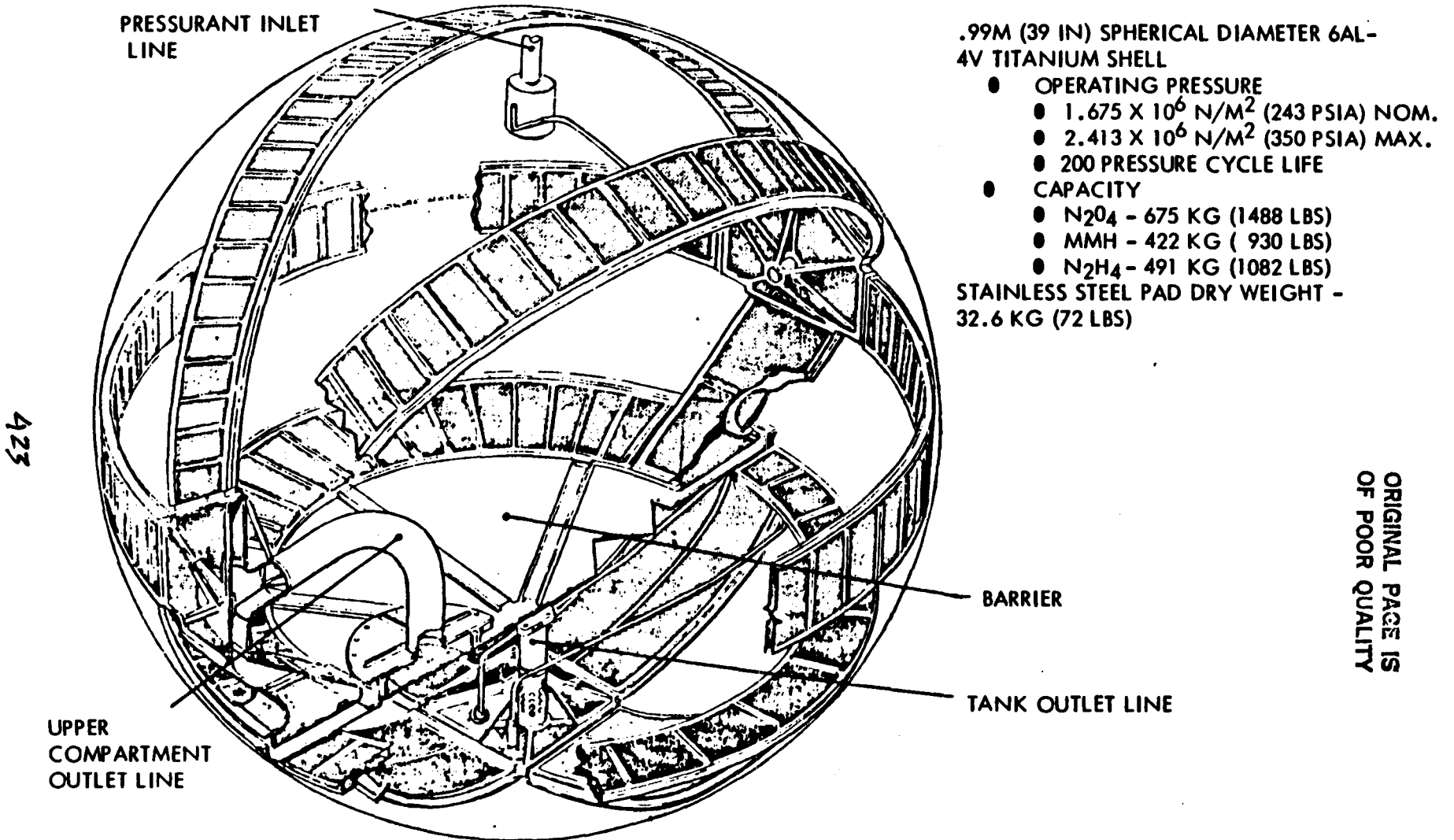

AFT REACTION CONTROL SYSTEM PROPELLANT TANK

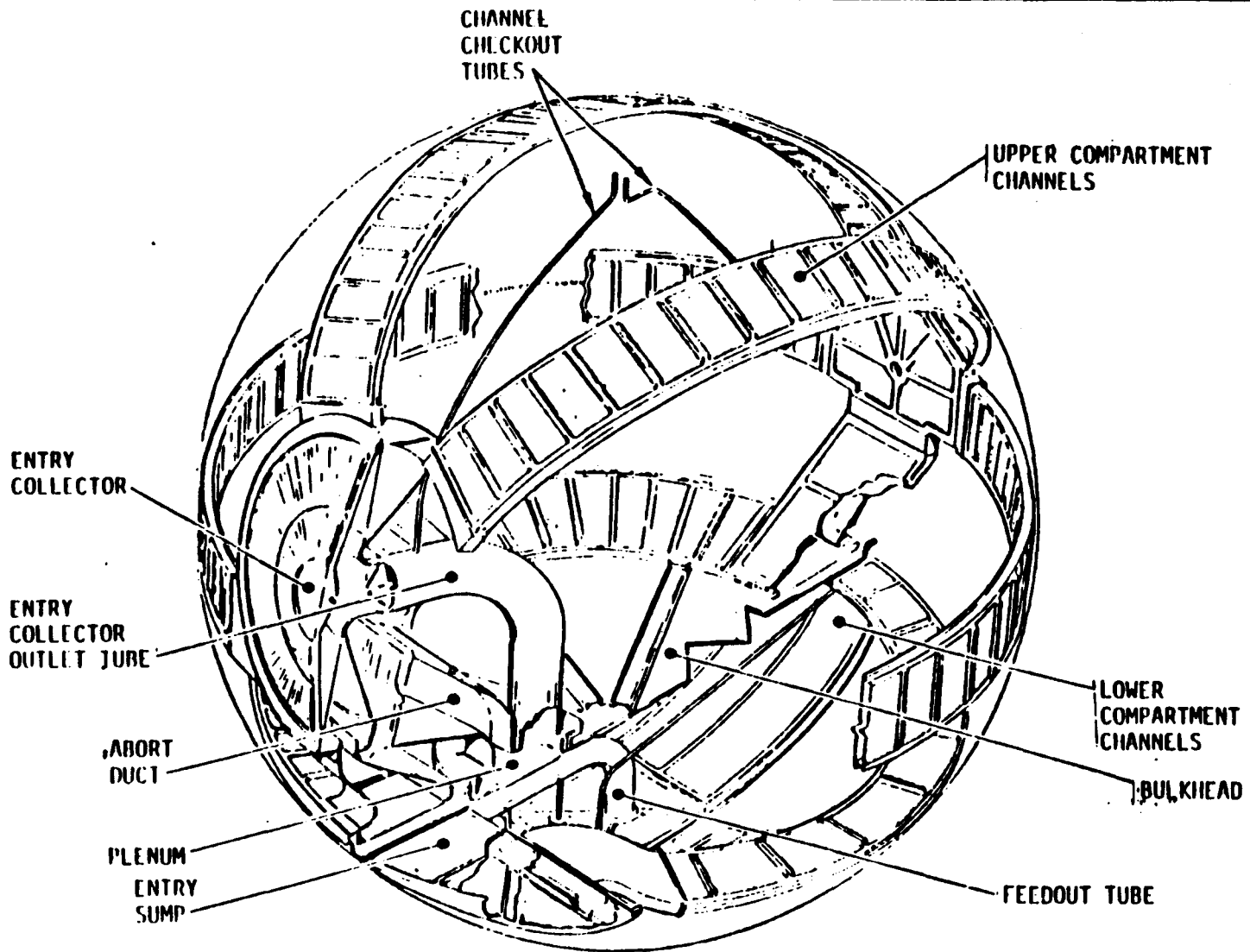

ORIGINAL PAGE IS
OF POOR QUALITY

424



AFT RCS TANK
PROPELLANT ORIENTATIONS

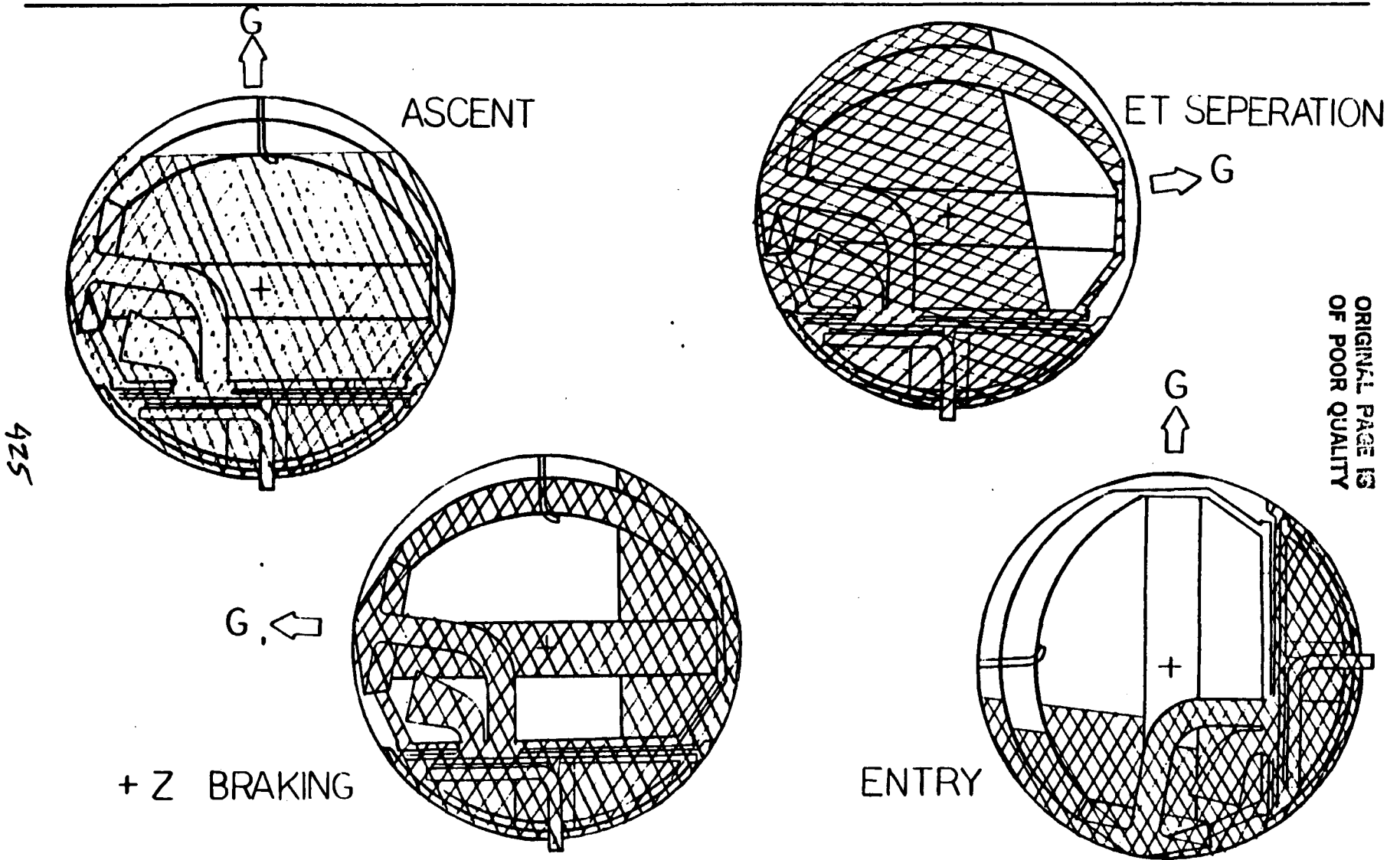

RCS PROPELLANT TANK
KEY DEVELOPMENT PROBLEMS ENCOUNTERED

LOW G PERFORMANCE CERTIFICATION BY ANALYSIS

- DIRECT TEST NOT FEASIBLE WITHOUT ZERO G PROPELLANT LABORATORY
- GAS FREE EXPULSION ASSURED WHEN $B.P. \geq (\Delta P_{START} + \Delta P_{S.S.}) \times SF$
 - $\Delta P_{START} f$ (NUMBER OF THRUSTERS STARTING)
 - $\Delta P_{S.S.} = \Delta P_E + \Delta P_V + \Delta P_H + \Delta P_{VIS}$
- LIMITED OPERATION WITH GAS INGESTION PERMITTED WHEN $\Delta P_{REHEAL} > (\Delta P_{S.S.}) \times SF$
- INITIAL PERFORMANCE CERTIFIED TO STEADY STATE REQUIREMENTS WITH 1.15 SF
 - MATH MODELS VALIDATED BY 1-G ELEMENT AND SUB ASSEMBLY TESTS
 - LOW-G EXPULSIONS SIMULATED BY 1-G MASKED SCREEN TESTS
- UNEXPECTED EFFECTS OF START TRANSIENT ON TANK OPERATION CAUSED CAUTION
 - SF RAISED TO 1.5
 - TOTAL GAS INGESTION LIMITED TO 164 CC (10 IN³) PER MISSION
- MISSION REQUIREMENTS REDUCED TO ACCOMMODATE START TRANSIENT CAPABILITIES
 - LIMITED FRCS THRUSTER USAGE TO 3 (WAS) 5
 - LIMITED ARCS THRUSTER USAGE TO 5 (WAS) 7
 - REQUIRES OVERFILL OF ARCS TANKS TO KEEP GAS OUT OF LOWER COMPARTMENT

ON-ORBIT SCREEN DRYOUT

- CAUSED BY CONVECTIVE MASS TRANSFER (PRESSURANT FLOW OVER SCREENS)
- RESOLVED BY SWIRL DIFFUSER

426

ORIGINAL PAGE 13
OF POOR QUALITY

RCS PROPELLANT TANK
KEY DEVELOPMENT PROBLEMS (CONTINUED)

DEVELOPMENT OF PAD BUBBLE POINT VERIFICATION TECHNIQUE INHIBITED BY N₂O₄ SCREEN DRYOUT

- SPECIAL CONTROLS AND TECHNIQUES DEVELOPED

SCREEN REPAIR TECHNIQUES REQUIRED TO SEAL PORE OPENINGS CREATED DURING MANUFACTURING

- SILVER/TIN SOLDER USED
- MMH CONTAMINATED WITH FREON CORRODES SILVER SOLDER
- PRESENCE OF FREON CONTAMINATION QUALITATIVELY SCREENED WITH SOLDER REPAIR DOTS

PAD SENSITIVITY TO SHOCK AND VIBRATION ENVIRONMENT UNKNOWN

- UNCERTAIN DURING HANDLING, TRANSPORTATION, AND BOOST ENVIRONMENTS
- PAD STRAIN GAGED AND SUBJECTED TO QUALIFICATION TEST ENVIRONMENTS
- STRESS AND FATIGUE ANALYTICAL MODELS UPDATED BASED ON RESPONSE DATA DURING ENVIRONMENTAL TESTS

TANK GIRTH WELD AND REPAIR

- SPECIAL TESTS WERE CONDUCTED TO VERIFY WELD STRESS/STRAIN CHARACTERISTICS OF MISMATCHED WELD LANDS
- TECHNIQUES WERE DEVELOPED TO REPAIR OR REPLACE INTERNAL PAD BY CUTTING TANK APART AND REPLACEMENT OF UPPER HEMISPHERE

427

ORIGINAL PAGE IS
OF POOR QUALITY



FLIGHT USAGE OF RCS PROPELLANT

PROPELLANT QUANTITY (OX + FU)

		STS-1			STS-2			STS-3		
		F	L	R	F	L	R	F	L	R
LOADED	KG	.888	999	999	892	1001	1001	881	1000	999
	LB	(1957)	(2203)	(2203)	(1967)	(2208)	(2208)	(1943)	(2205)	(2202)
ASCENT	KG	68	68.5	40	47	65	68	58	85	83
	LB	(150)	(151)	(89)	(103)	(143)	(151)	(128)	(188)	(183)
ON-ORBIT	KG	186	102	128	202	236	209	771	333	359
	LB	(410)	(225)	(283)	(446)	(522)	(460)	(1700)	(735)	(791)
DE-ORBIT	KG	16	5.5	1.5	-	40	38	-	39	37
	LB	(36)	(12)	(3)	-	(88)	(84)	-	(85)	(81)
FRCS DUMP	KG	-	-	-	517	-	-	78	-	-
	LB	-	-	-	(1141)	-	-	(172)	-	-
ENTRY	KG	-	243	228.5	-	413	418	-	261	260
	LB	-	(535)	(503)	-	(910)	(922)	-	(575)	(574)
TOTAL	KG	270	419	398	766	754	733	907	718	739
	LB	(596)	(923)	(878)	(1690)	(1663)	(1617)	(2000)	(1583)	(1629)
BUDGETED	KG	218	312	316	445	516	561	779	958	950
	LB	(480)	(689)	(697)	(982)	(1137)	(1237)	(1718)	(2112)	(2095)

428

ORIGINAL PAGE IS
OF POOR QUALITY



RCS PROPELLANT TANK
CERTIFICATION STATUS

STRUCTURAL QUALIFICATION

- TANK SHELLS QUALIFIED FOR 100 MISSION LIFE
- OV-102 PAD QUALIFIED FOR 17 MISSION LIFE
- OV-099 AND SUBS PAD BEING QUALIFIED TO 100 MISSION LIFE
 - ARCS - JULY 1982
 - FRCS - JULY 1983

PERFORMANCE CERTIFICATION

- OV-102 TANKS CERTIFIED FOR LIMITED THRUSTER USAGE
 - FRCS 2SS + 3P
 - ARCS 1SS + 3P
 - CAN BE RECERTIFIED TO 2SS + 4P
- OV-099 AND SUBS TO BE CERTIFIED
 - FRCS - SAME AS OV-102
 - ARCS - 1SS + 5P
 - WSTF TEST - NOVEMBER 1982
 - CERTIFICATION ANALYSES - MARCH 1983

ORIGINAL PAGE IS
OF POOR QUALITY

429



ORBITER OMS AND RCS TECHNOLOGY

CONCLUSIONS

- SUCCESSFUL FLIGHTS OF ORBITER HAVE PROVEN THE VIABILITY OF SURFACE TENSION DEVICES FOR SHUTTLE APPLICATION

- EXTRAPOLATION TO OTHER APPLICATIONS INVOLVING STORABLE PROPELLANTS SHOULD BE A SUBSTANTIALLY EASIER TASK BECAUSE OF OMS AND RCS TECHNOLOGY

430

ORIGINAL PAGE IS
OF POOR QUALITY



EP6598

ORGANIZATION: STRUCTURES & PROPULSION LABORATORY EP43	MARSHALL SPACE FLIGHT CENTER CRYOGENIC FLUID TRANSFER ORBITAL TRANSFER VEHICLE	NAME: LEON J. HASTINGS
CHART NO.:		DATE: JUNE 1982

PRESENTATION OUTLINE

✓ **REQUIREMENT OVERVIEW**

- OTV CONFIGURATIONS
 - SIZE RANGE
 - INTERNAL HARDWARE
- GENERAL REFUELING CONCEPT

DESIGN/TECHNOLOGY CONSIDERATIONS

- TANK CHILLDOWN
 - INITIAL TANK CONDITIONS
 - CHILLDOWN THERMODYNAMICS
- TANK FILL
 - FILL THERMODYNAMICS
 - SUPPLY TANK EFFECTS
- SPECIAL ISSUES
 - RESIDUALS
 - START BASKET OR TANK PRESENCE

CONCLUSIONS

ORIGINAL PAGE IS
OF POOR QUALITY

2011 0011

432

OTV CONFIGURATION OVERVIEW

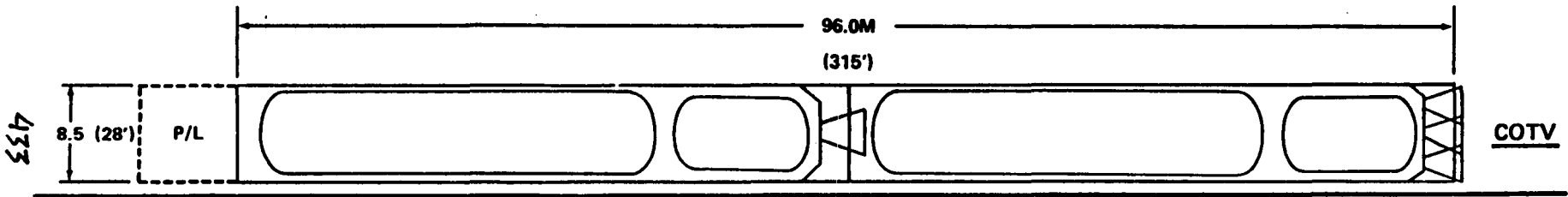
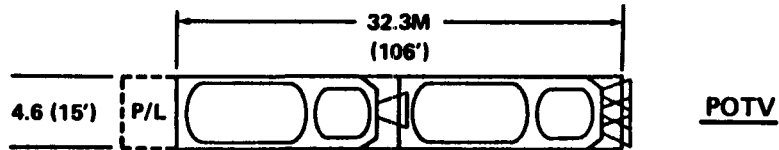
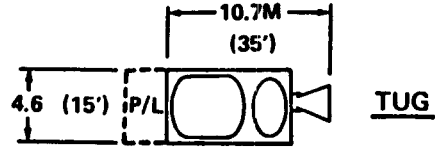

ORIGINAL PAGE IS
OF POOR QUALITY

VEHICLE	PROPELLANT	TANK VOLUME M ³ (FT ³)	PROPELLANT LOAD KG (LB)	OPERATING PRESS kN/M ² (PSI)	MISSION
POTV	LO ₂	41 (1450)	44,550 (99,000)	172 (25)	4 MEN FROM LEO TO GEO AND RETURN OR
	LH ₂	116 (4100)	7,875 (17,500)	172 (25)	100K TO GEO AND 60K RETURN WITH GEO REFUELING
COTV	LO ₂	183 (6460)	197,400 (438,600)	172 (25)	500K FROM LEO TO GEO
	LH ₂	549 (19,400)	37,260 (82,800)	172 (25)	

433

OTV CRYOGEN MANAGEMENT CONSIDERATIONS

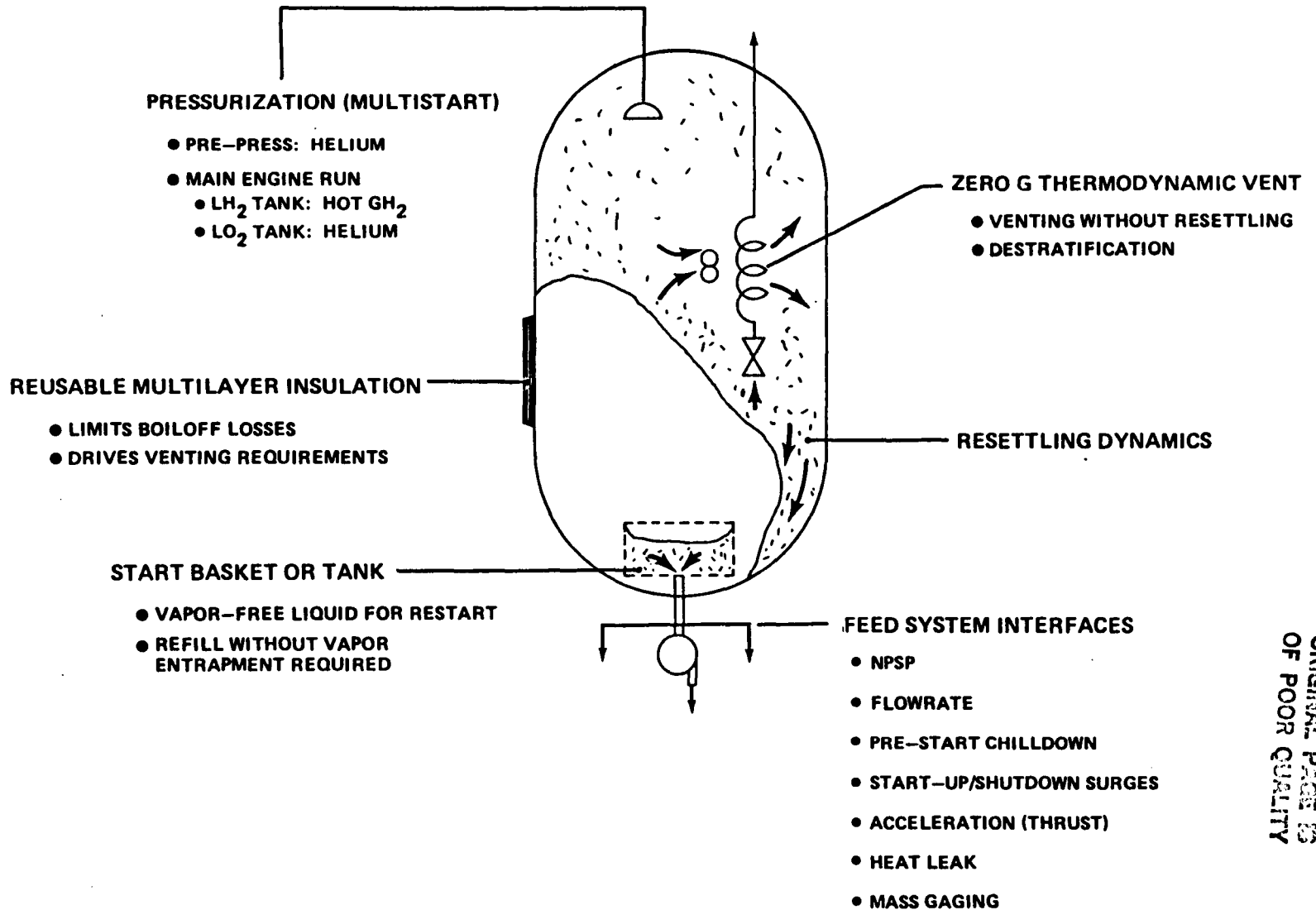

434

ORIGINAL PAGE IS
OF POOR QUALITY

ORBITAL CRYOGEN TRANSFER CONSIDERATIONS

SUPPLY TANK

- STORAGE/VENTING
- ACQUISITION/EXPULSION
 - LIQUID ORIENTATION
 - BOILING/SCREEN DRYING
 - PRESSURIZATION
 - OUTFLOW RATE
 - RESIDUALS

RECEIVER (OTV)

- PRECHILL
 - INLET FLOWRATE/DISTRIBUTION
 - WALL CHILLDOWN
- NO VENT FILL
 - NON-EQUILIBRIUM THERMODYNAMICS
 - HELIUM PRESENCE
- START BASKET REFILL
- MASS GAUGING

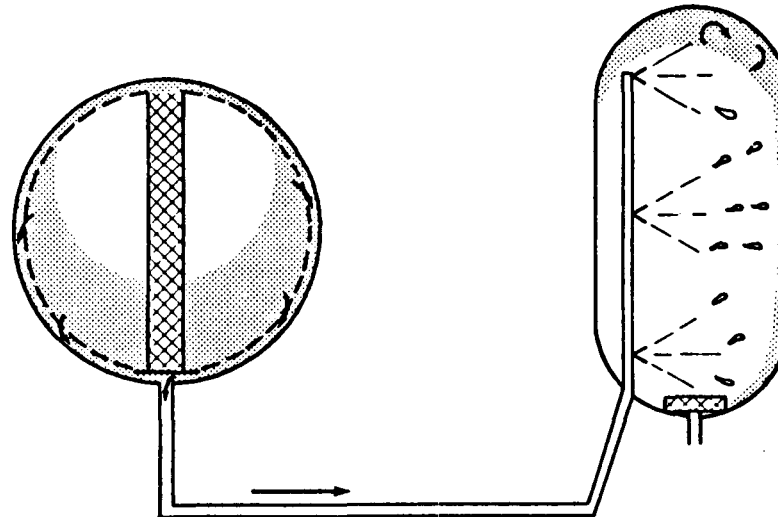

TRANSFER LINE

- CHILLDOWN – PRESSURE SURGES
- FLUID LOADS
 - TRANSIENT
 - STEADY-STATE

435

ORIGINAL PAGE IS
OF POOR QUALITY

EP6599

ORGANIZATION: STRUCTURES & PROPULSION LABORATORY EP43	MARSHALL SPACE FLIGHT CENTER CRYOGENIC FLUID TRANSFER ORBITAL TRANSFER VEHICLE	NAME: LEON J. HASTINGS
CHART NO.:		DATE: JUNE 1982

PRESENTATION OUTLINE

REQUIREMENT OVERVIEW

- OTV CONFIGURATIONS
 - SIZE RANGE
 - INTERNAL HARDWARE
- GENERAL REFUELING CONCEPT

✓ **DESIGN/TECHNOLOGY CONSIDERATIONS**

- TANK CHILLDOWN
 - INITIAL TANK CONDITIONS
 - CHILLDOWN THERMODYNAMICS
- TANK FILL
 - FILL THERMODYNAMICS
 - SUPPLY TANK EFFECTS
- SPECIAL ISSUES
 - RESIDUALS
 - START BASKET OR TANK PRESENCE

CONCLUSIONS

ORIGINAL PAGE IS
OF POOR QUALITY

436

INITIAL WALL TEMPERATURE EFFECTS ON POTV
LH₂ TANK PRESSURES AFTER FILL

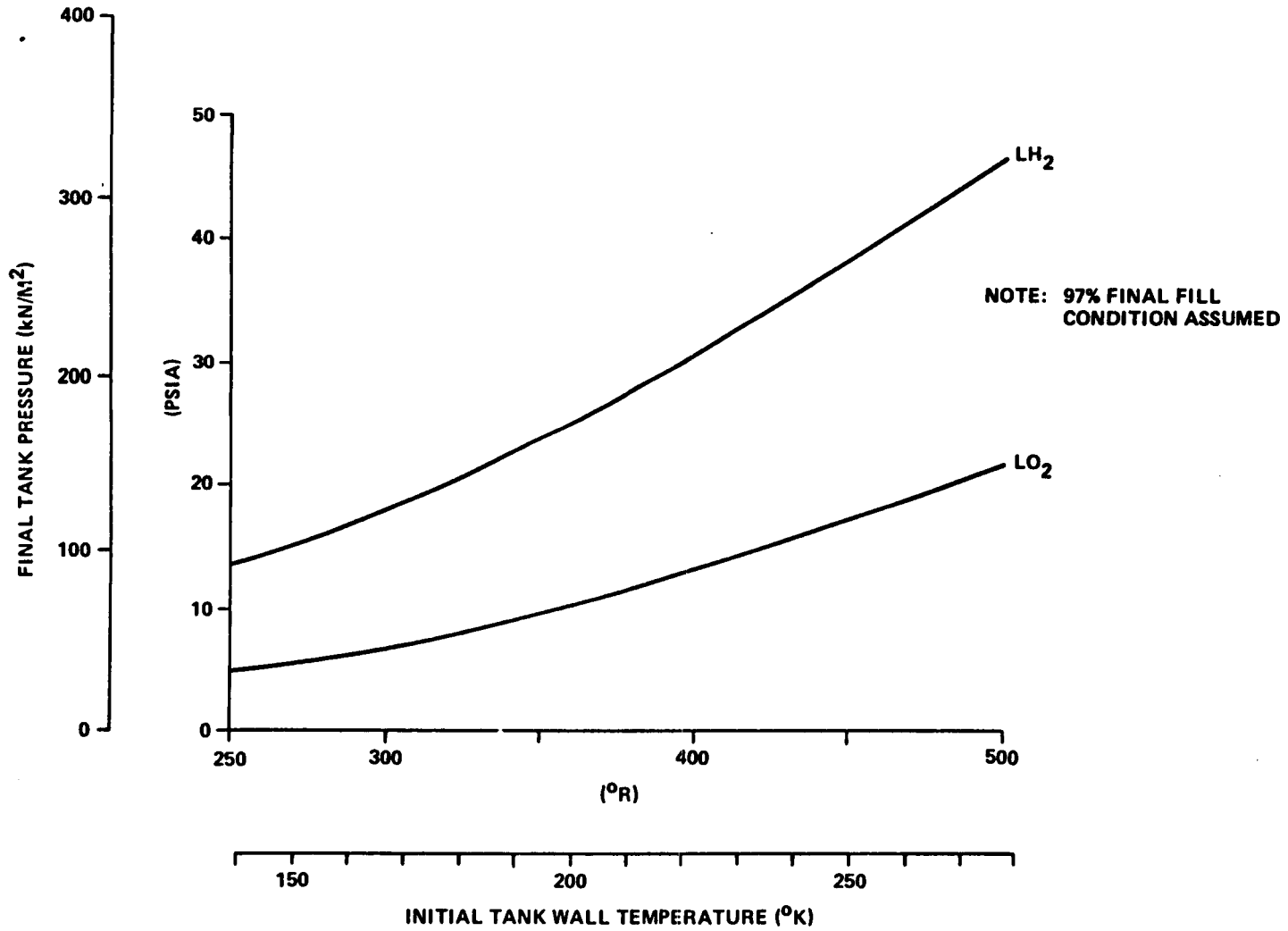

437

ORIGINAL PAGE IS
OF POOR QUALITY

POTV LH₂ TANK THERMODYNAMICS DURING CHILLDOWN

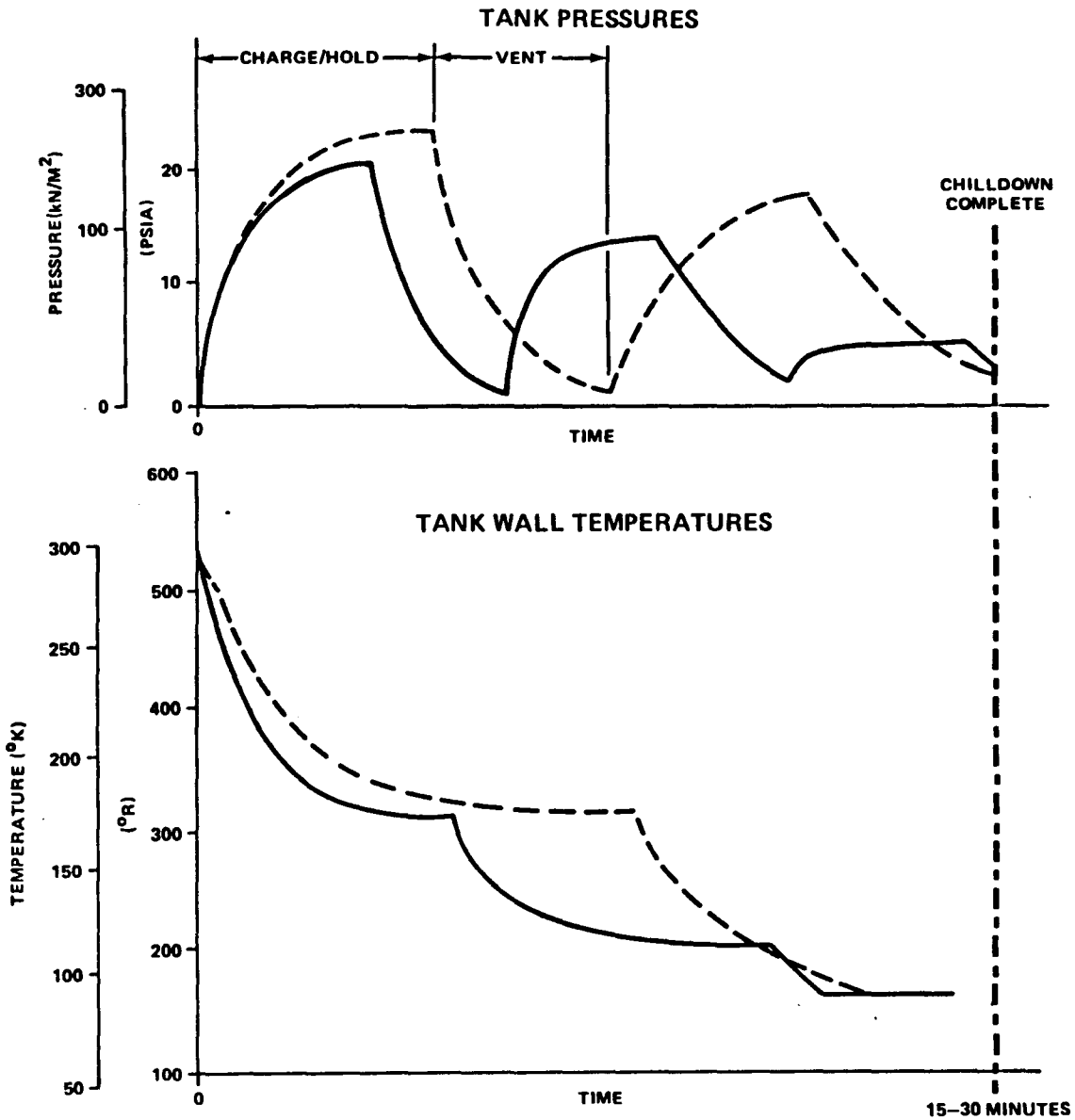

438

ORIGINAL PAGE IS
OF POOR QUALITY

POTV LH₂ TANK PRESSURES DURING ORBITAL FILL

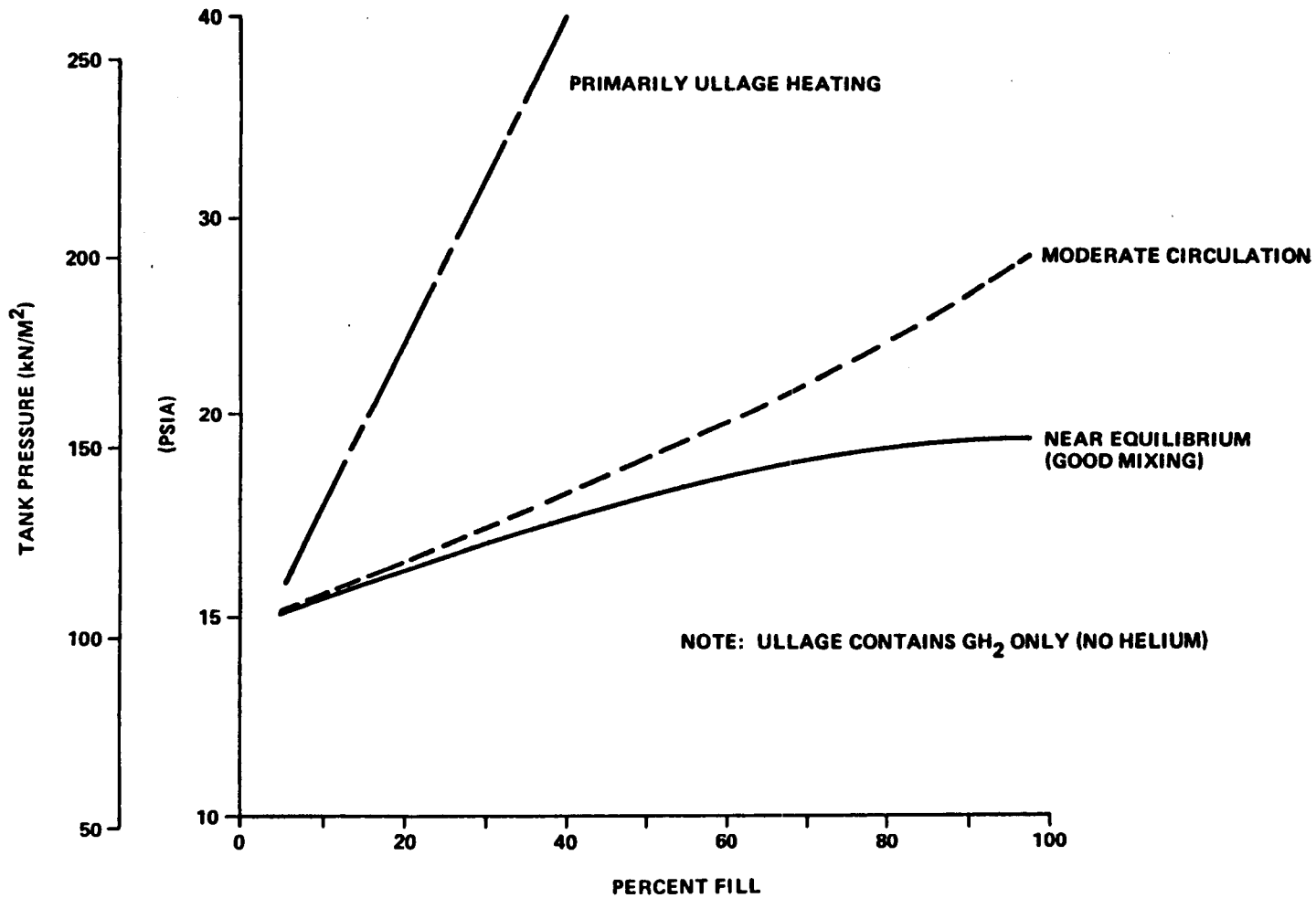

439

ORIGINAL PAGE IS
OF POOR QUALITY

ENTERING LH₂ VAPOR PRESSURE EFFECTS ON POTV
TANK PRESSURE AT FILL COMPLETION

440

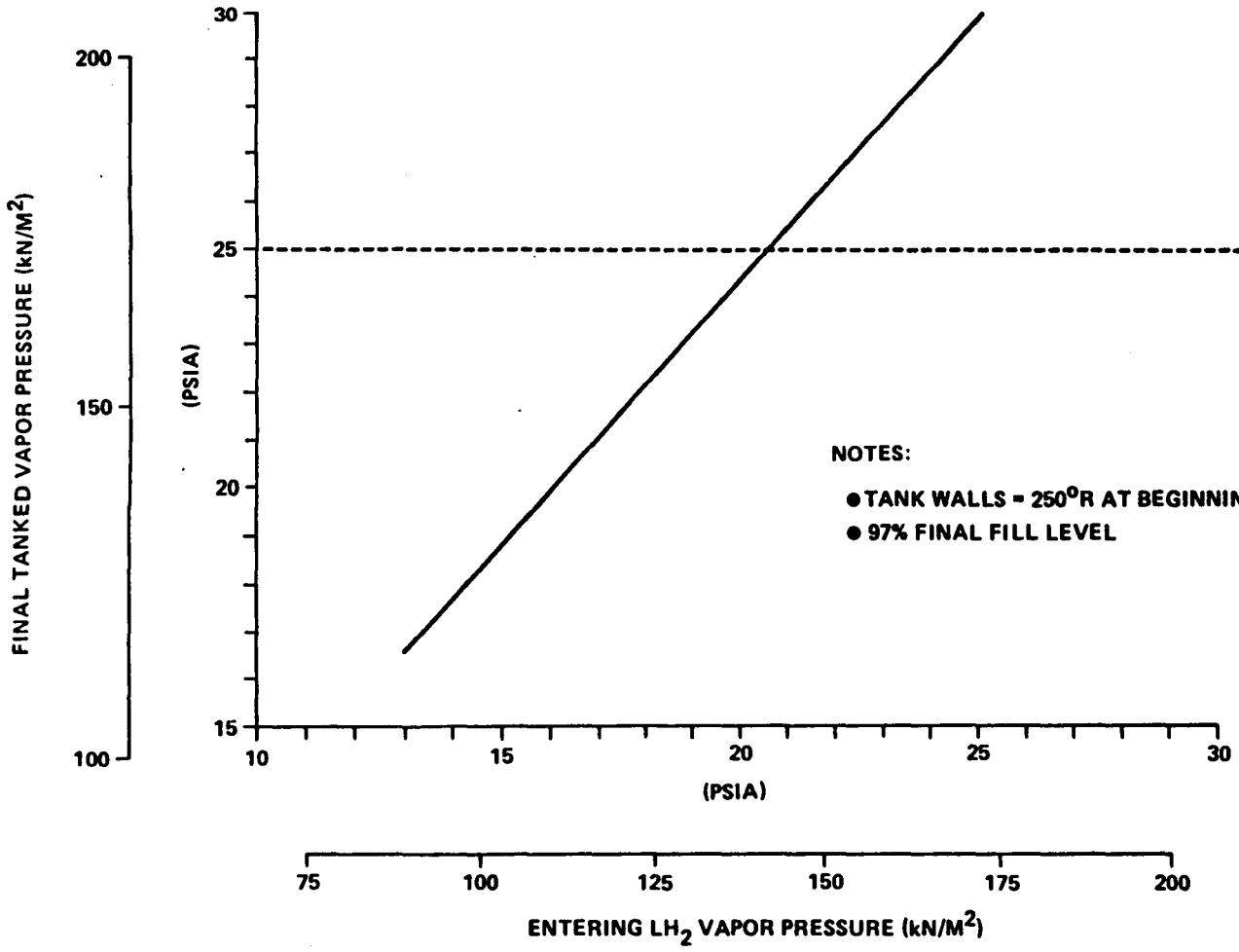

ORIGINAL PAGE IS
OF POOR QUALITY

LH₂ SUPPLY TANK THERMODYNAMIC CONDITIONS

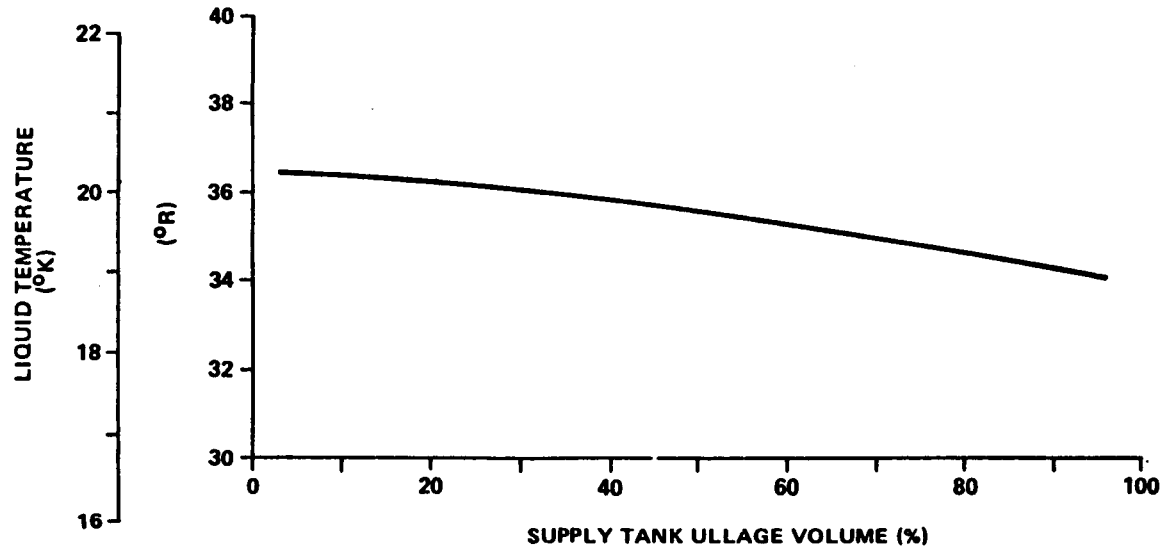

NOTE:

SUPPLY TANK
VOLUME = 85M³ (3000 FT³)

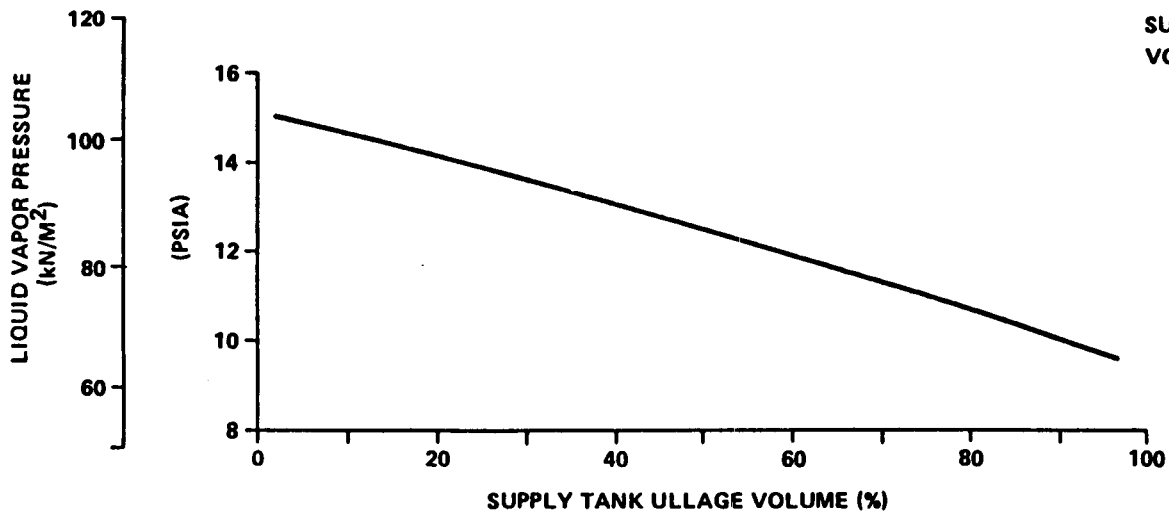

ORIGINAL DRAWING
OF POOR QUALITY

44)

RESIDUAL HELIUM PARTIAL PRESSURES
AT 97% FILL LEVEL

ORIGINAL PAGE IS
OF POOR QUALITY

442

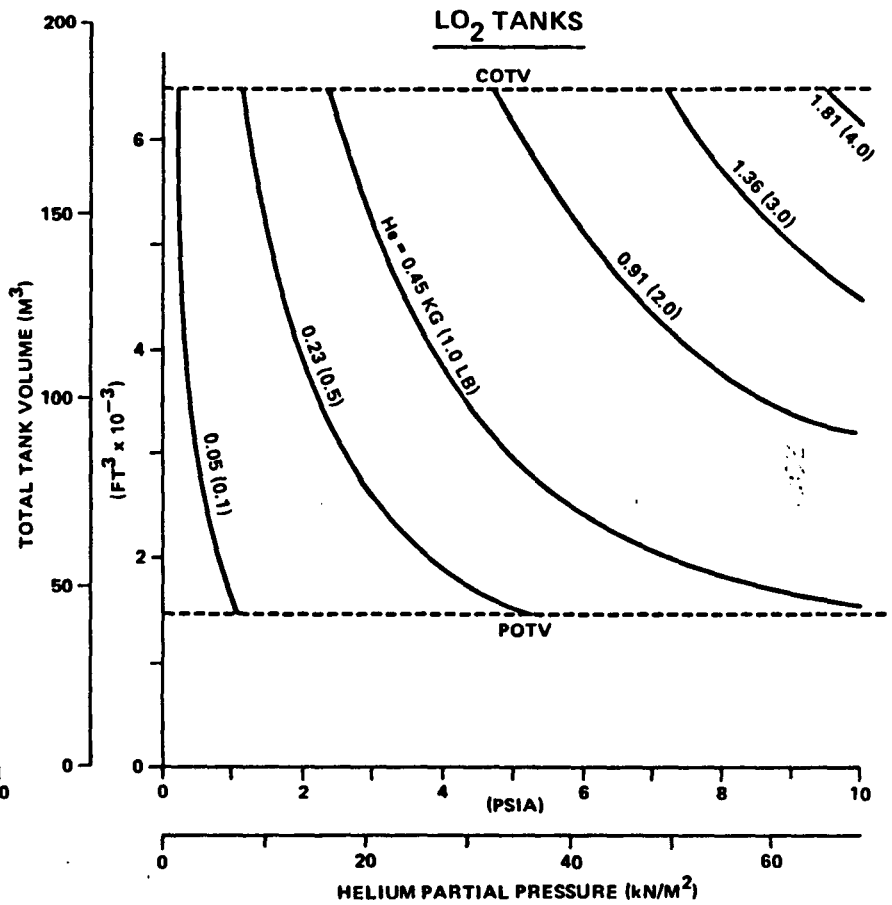
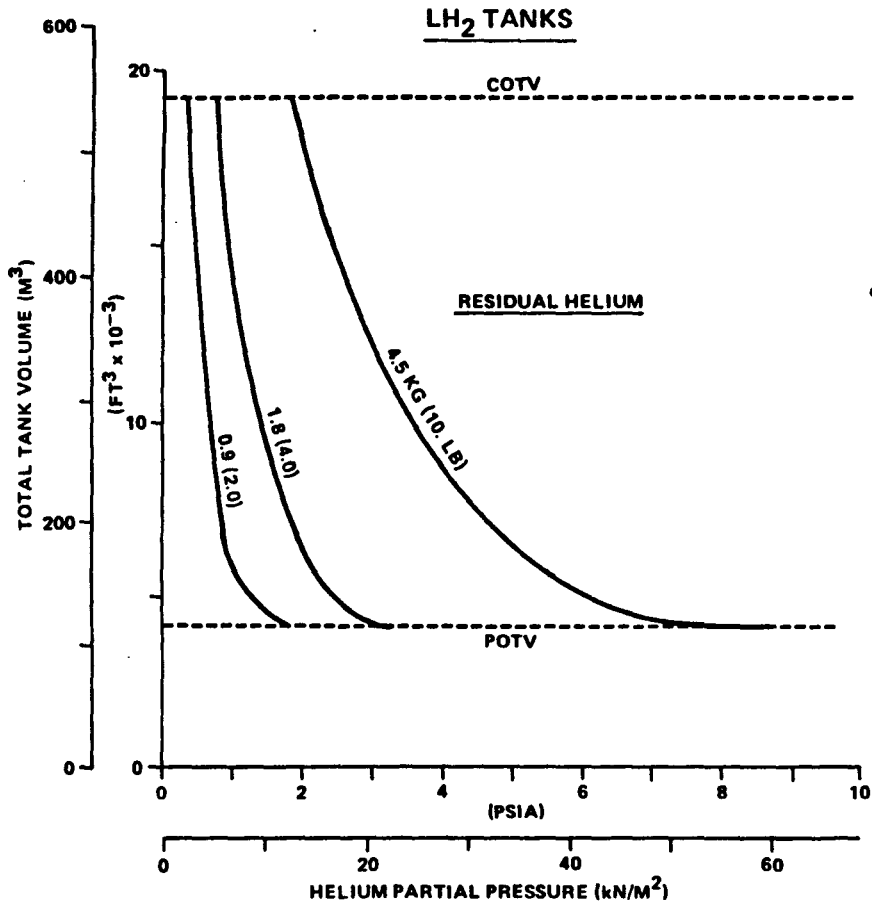

PROPELLANT BUBBLE COLLAPSE
BY INCREASING ULLAGE PRESSURE

ORIGINAL PAGE IS
OF POOR QUALITY

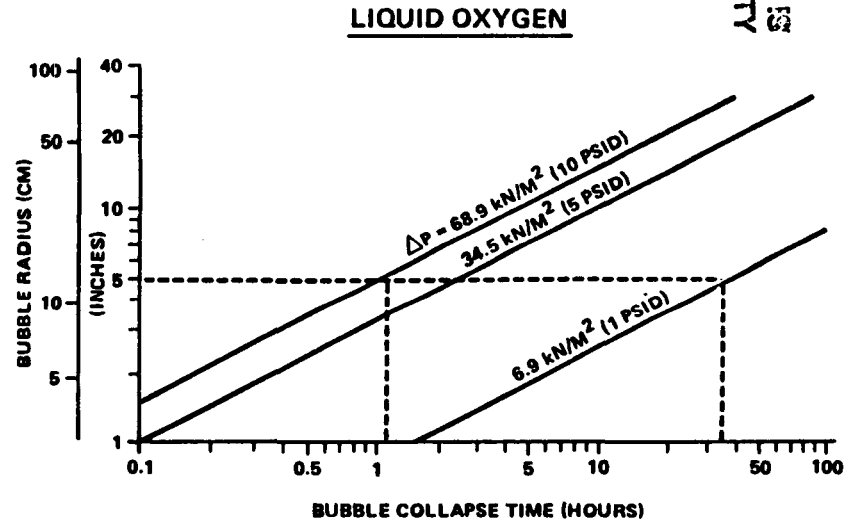
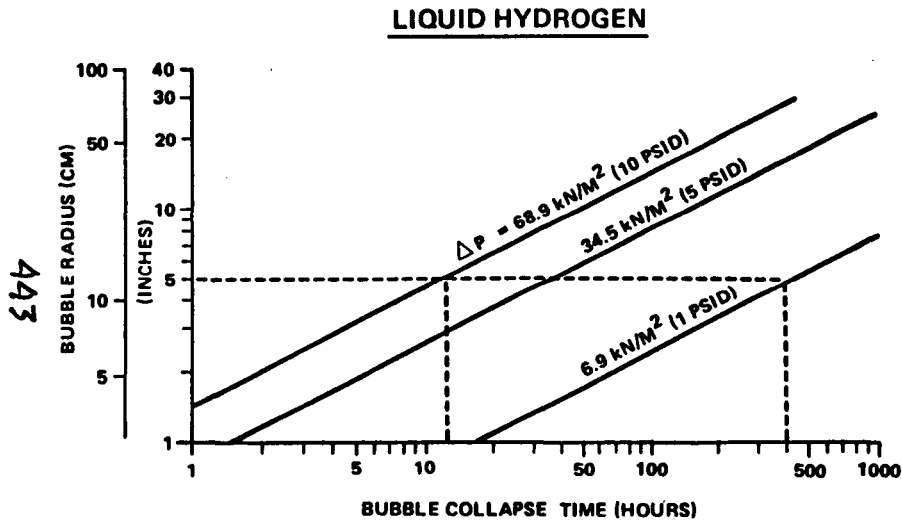

443

NOTE: ΔP = ULLAGE PRESSURE – SATURATION PRESSURE

CONCLUSION: COLLAPSE OF BUBBLES IN START BASKETS
COULD REQUIRE ACTIVE CIRCULATION

EP6600

ORGANIZATION: STRUCTURES & PROPULSION LABORATORY EP43	MARSHALL SPACE FLIGHT CENTER CRYOGENIC FLUID TRANSFER ORBITAL TRANSFER VEHICLE	NAME: LEON J. HASTINGS
CHART NO.:		DATE: JUNE 1982

PRESENTATION OUTLINE

REQUIREMENT OVERVIEW

- OTV CONFIGURATIONS
 - SIZE RANGE
 - INTERNAL HARDWARE
- GENERAL REFUELING CONCEPT

DESIGN/TECHNOLOGY CONSIDERATIONS

- TANK CHILLDOWN
 - INITIAL TANK CONDITIONS
 - CHILLDOWN THERMODYNAMICS
- TANK FILL
 - FILL THERMODYNAMICS
 - SUPPLY TANK EFFECTS
- SPECIAL ISSUES
 - RESIDUALS
 - START BASKET OR TANK PRESENCE

✓ CONCLUSIONS

ORIGINAL PAGE IS
OF POOR QUALITY

449

POTV PROPELLANT TRANSFER TIMELINE

445

- EVENT
- LH₂ TRANSFER
 - 1) INITIAL LH₂ TANK VENT
 - INJECT LH₂ AND HOLD
 - VENT TANK
 - 2) PRECHILL
 - INJECT LH₂ AND HOLD
 - VENT TANK
 - INJECT LH₂ AND HOLD
 - VENT TANK
 - 3) FILL
 - LH₂ TRANSFER
 - TOPPING FLOW RATE

 - LO₂ TRANSFER
 - 1) INITIAL LO₂ TANK VENT*
 - 2) FILL
 - LO₂ TRANSFER
 - TOPPING FLOW RATE

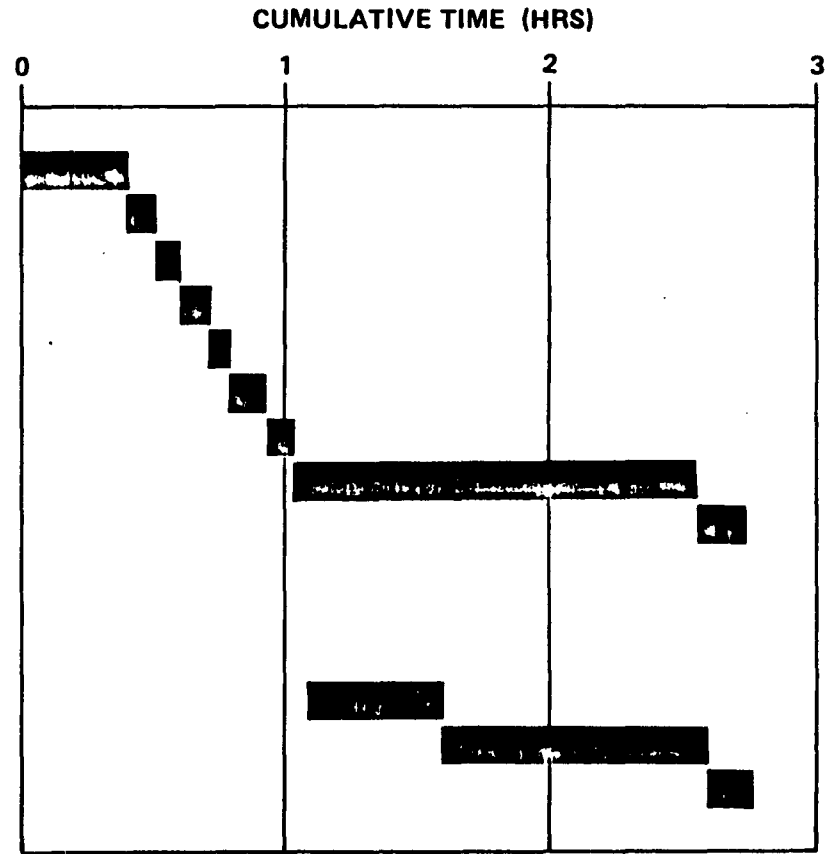

ORIGINAL PAGE IS OF POOR QUALITY

NOTES:

- TWO OR MORE ADDITIONAL VENT CYCLES REQUIRED IF HELIUM PRESENT
- TIMELINE IS FOR REFUELING TO 50% LEVEL

EP6595

ORGANIZATION: STRUCTURES & PROPULSION LABORATORY EP43	MARSHALL SPACE FLIGHT CENTER CRYOGENIC FLUID TRANSFER ORBITAL TRANSFER VEHICLE	NAME: LEON J. HASTINGS
CHART NO.:		DATE: JUNE 1982

CONCLUSIONS

PRE-CHILL PREPARATIONS

- DILUTION OF HELIUM RESIDUALS PRIOR TO REFUELING REQUIRED TO PREVENT:
 - EXCESSIVE PRESSURES AT END OF FILL
 - INACCURATE KNOWLEDGE OF PROPELLANT VAPOR PRESSURES
 - START BASKET HELIUM ENTRAPMENT
 - INACCURATE THERMODYNAMIC MASS GAUGING
- APPROXIMATE DILUTION LEVELS REQUIRED (POTV)
 - LH₂ < .9 KG (2 LBS)
 - LO₂ < .09 KG (.2 LBS)

} FURTHER DILUTION REQUIRED IF
THERMODYNAMIC MASS GAUGING
UTILIZED
- PROCEDURAL/TECHNOLOGY CONCERNS
 - DURATION OF VENT/HOLD CYCLES
 - KNOWLEDGE OF HELIUM RESIDUAL MAGNITUDE

ORIGINAL PAGE IS
OF POOR QUALITY

446

ORGANIZATION: STRUCTURES & PROPULSION LABORATORY EP43	MARSHALL SPACE FLIGHT CENTER CRYOGENIC FLUID TRANSFER ORBITAL TRANSFER VEHICLE	NAME: LEON J. HASTINGS
CHART NO.:		DATE: JUNE 1982

CONCLUSIONS

TRANSFER LINE/TANK CHILLDOWN:

- REQUIREMENT: REDUCE TRANSFER LINE/TANK WALL TEMPERATURES SUFFICIENTLY TO PREVENT EXCESSIVE LINE PRESSURE/FLOW SURGES AND TO ENABLE A NON-VENTED TANK FILL
- PROCEDURAL/TECHNOLOGY CONCERNS:
 - TANK CHARGE/HOLD/VENT CYCLE DEFINITION
 - SEMI-EMPIRICAL MODELING LACKS EXPERIMENTAL DATA
 - LACK OF HARDWARE EXPERIENCE
 - WALL CHILLDOWN CRITERION: CURRENT RANGE = 95°K TO 200°K (170°R TO 360°R)
 - CHARGE MASS/FLOWRATE SELECTION: CURRENT LH₂ RANGE = 20 TO 70 KG (40 TO 155 LB) @ .5 TO 1.5 KG/SEC (1 TO 3 LB/SEC)
 - LACK OF TRANSFER LINE CHILLDOWN EXPERIENCE – PREVENTION OF EXCESSIVE SURGES AND LINE LOADS
 - INSTRUMENTATION TO MONITOR CHILLDOWN PROCESS

ORIGINAL PAGE IS
OF POOR QUALITY

ORGANIZATION: STRUCTURES & PROPULSION LABORATORY EP43	MARSHALL SPACE FLIGHT CENTER CRYOGENIC FLUID TRANSFER ORBITAL TRANSFER VEHICLE	NAME: LEON J. HASTINGS
CHART NO.:		DATE: JUNE 1982

CONCLUSIONS

TANK FILL

- REQUIREMENT: LH₂ & LO₂ TANK FILL WITHOUT VENTING
- PROCEDURAL/TECHNOLOGY CONCERNS:
 - ASSURANCE OF ADEQUATE CIRCULATION TO MAINTAIN NEAR-THERMAL EQUILIBRIUM, i.e., LOW PRESSURES
 - GOOD MIXING/HEAT EXCHANGE BETWEEN ULLAGE/LIQUID REQUIRED
 - EXISTING SEMI-EMPIRICAL MODELS LACK EXPERIMENTAL DATA
 - LACK OF IN-FLIGHT HARDWARE EXPERIENCE
 - MECHANICAL MIXER PROBABLY REQUIRED
 - LACK OF ZERO-G MASS GAUGING DEVICE
 - SPECIAL FILL PROVISIONS FOR START BASKET
 - BLEED LINE FOR DIRECT FILL OF BASKET
 - ACTIVE CIRCULATION TO ASSURE ENTRAPPED VAPOR COLLAPSE
 - SUPPLY TANK VAPOR PRESSURE $\leq 2.2 \text{ kN/M}^2$ (15 PSIA), NO HELIUM PASSAGE ALLOWABLE
 - PREVENTION OF EXCESSIVE TRANSFER LINE LOADS AT $\dot{m} = 1-1.5 \text{ KG/SEC}$ (2-3 LB/SEC)

ORIGINAL PAGE IS
OF POOR QUALITY

448