

1982

NASA/ASEE SUMMER FACULTY RESEARCH FELLOWSHIP PROGRAM
MARSHALL SPACE FLIGHT CENTER
THE UNIVERSITY OF ALABAMA

THERMAL RADIATION VIEW FACTOR
Methods, Accuracy and Computer-Aided Procedures

Prepared By:	Prasanna V. Kadaba, Ph.D.
Academic Rank:	Associate Professor
University and School:	Georgia Institute of Technology School of Mechanical Engineering
NASA/MSFC	
(Laboratory)	Structures and Propulsion
(Division)	Engineering and Analysis
(Branch)	Life Support and Environmental Branch
MSFC Counterpart:	J. D. Moss/L. D. Turner
Date:	August 1982
Contract No.	NGT-01-002-099 (University of Alabama)

THERMAL RADIATION VIEWFACTOR
METHODS, ACCURACY AND COMPUTER-AIDED PROCEDURES

BY

PRASANNA V. KADABA, PH.D
ASSOCIATE PROFESSOR OF MECHANICAL ENGINEERING
GEORGIA INSTITUTE OF TECHNOLOGY
ATLANTA, GEORGIA 30332

ABSTRACT

Exposed orbiting equipment is subjected to temperature variations caused by impinging solar radiation, the reflected energy from the earth, the internal heat sources and sinks and the mutual radiation among themselves. The satisfactory operation of these packages depends on maintaining them within the predetermined acceptable temperature range. The computer-aided thermal analysis programs can predict these results prior to stationing of these orbiting equipment in various attitudes with respect to the sun and the earth.

Principle mechanism of heat transfer in space is by thermal radiation and for thermally diffuse surfaces the heat transfer rates depends on the radiation viewfactors. Complexity of the surface geometries suggests the use of numerical schemes for the determination of these viewfactors.

Basic definitions and standard methods which form the basis for various digital computer methods have been presented followed by a brief discussion of various numerical methods. The physical model and the mathematical methods on which a number of available programs are built have been summarized. The strength and the weaknesses of the methods employed, the accuracy of the calculations and the time required for computations are evaluated and discussed. Based on this study, the situations where accuracies are important for energy calculations have been identified. Methods to save computational times are proposed. Guide to best use of the available programs at several centers and the future choices for efficient use of digital computers are included in the recommendations.

Acknowledgments:

The author of this report wishes to gratefully acknowledge the technical support given in selecting the research topic and presenting the clear perception of the problem by Messrs. J. D. Moss and L. D. Turner as well as Dr. W. R. (Randy) Humphries, Chief, Life Support and Environmental Branch. The arduous task of selecting NASA/ASEE Fellows and matching them with timely topics of interests by the personnel at the University of Alabama (represented by Dr. B. F. Barfield) and at MSFC (represented by Mr. Marion I. Kent) and the immeasurable success they have achieved with limited financial support is noted. It is the sincere wish of this author that such programs be continued with greater vigor and larger numbers in order to expose the academic faculty to the forefront of technologies and carry the message of this mission to the budding generation of students they educate.

The author wishes to acknowledge the careful typing of this manuscript as well as the detailed version by Ms. Loretta Hereford. Without her cheerful and dedicated efforts the successful completion of this project in so short a time would not have been possible. The support of visual aids department in preparing the graphics and tables is worthy of praise. The cordial association of the other members of the team in the Life Support and Environmental Branch, MSFC, is greatly appreciated.

TABLE OF CONTENTS

	<u>Page No.</u>
Abstract	XXII - i
Acknowledgments	XXII - ii
List of Figures	XXII - iv
List of Tables	XXII - iv
 Introduction	 XXII - 1
Basic Concepts	XXII - 2
Radiosity Method	
Hottel's Method	
Gebhart's Method	
Oppenheim's Electric Network	
Analog Method	
 Radiation View Factor	 XXII - 8
Nusselt Method	
Ray Tracing Technique	
Double Integration - Double Summation	
Method	
Hottel's Stretch Film Method	
Contour Integration Method	
Monte-Carlo Method	
 Numerical Procedures	 XXII - 19
Iterative Procedure	
Finite Difference Procedure	
Finite Element Procedure	
Approximate Analytical Solution	
Monte-Carlo Procedure	
 Accuracy and Computational Time	 XXII - 25
 Computer Programs	 XXII - 34
 Conclusions and Recommendations	 XXII - 45
 References	 XXII - 48
 Appendix	 XXII - A1
View Factor Calculations Using	
TRASYS	

LIST OF FIGURES

<u>Figure No.</u>	<u>Title</u>	<u>Page No.</u>
1	Representation of View Factor	XXII - 3
2	Radiosity and Radiative Exchange Between Surfaces	XXII - 5
3	Geometry of Unit-Sphere Method for Obtaining Configuration (View) Factors	XXII - 9
4	Crossed-String Representations for Two-Dimensional View Factors	XXII - 13

LIST OF TABLES

<u>Table No.</u>	<u>Title</u>	<u>Page No.</u>
1	Percentage Error in the Numerical Calculation of the View Factor Between Two Surfaces of Equal Breadth ($L = H$)	XXII - 27
2	Computer Programs Having Heat Transfer Analysis Capabilities Selected for Survey	XXII - 35
3	Survey of Computer Programs Capabilities used in Heat Transfer Analysis	XXII - 39

Thermal Radiation Viewfactor
Methods, Accuracy and Computer-Aided Procedures

Introduction

The orbital Space Laboratory with its door open while in the earth's orbit is exposed to the solar radiation, the earth's albedo and the mutual radiation from the parts of the spacecraft itself. Some of the experimental packages are passive and, hence, they experience a wide range of temperatures due to net radiative heat balance. This range of temperatures need to be predicted for various attitudes the space station will be held during its orbit¹. If the upper and low limits of temperatures are beyond the safe limit for satisfactory operation, these packages need to be protected from undesirable radiative heat transfer. Other experimental packages are mounted on coldplates with its ability to heat sink either heat generated from the equipment itself or the extraneous radiative heat transfer. The nature of their arrangements suggests that these components need to be held in a narrow range of temperature limits for their satisfactory operation and control by the crew members. A successful space laboratory mission requires optimization of thermal performance of all the components of the system consistent with the critical weight/cost considerations. It is to be expected that the predicted temperature variations of components of the space laboratory obtained from analytical methods will be verified by selective monitoring of the temperature sensors.

The expected temperature variations of the surfaces of the space laboratory experiments require nodal heat balance among the heat absorption, the heat generation, the heat conduction and the heat lost to outer space. Successful tracking of these parameters leads to unsteady state heat transfer problem since all the suggested parameters are time varying functions, often in asynchronous manner. It is natural to expect coincident spikes and valleys giving rise to the expected range in the temperature excursions of the space laboratory components. Here, the heat flow mechanism is radiative mode to and from the surfaces. Its evaluation is influenced by mutual radiation view factors² among the surfaces of the space laboratory as well as the views to the sun, the earth, and the celestial space. This report will discuss the methods available for their computations, the need for accuracy of these computations and the efficient use of the available computer programs to achieve these goals.

1

In the recently concluded space shuttle -4 mission (June-July), the shuttle was flown for 10 hours with its belly showing to sun in order to drive out possible moisture under the heat shield tiles by taking advantage of the temperature rise due to net radiative heat transfer to the surface.

2

Some of the other names are form factor, shape factor, configuration factor, geometric factor, etc.

Author's Note:

This report has been hurriedly put together due to lack of time at the tail end of the ten week-Fellowship program. The reader will come across open spots in a line. It should not be viewed as missing information. At other places there are evidences of overcrowding. It is hoped that the concerned readers will overlook these shortcomings and lack of professionalism in preparing this report. Thank you very much for your understanding.

Basic Concepts:

Basic definitions of geometric view factors for Lambertian surfaces³ are illustrated in Figure 1. The differential view factor between elemental areas dA_i and dA_j as illustrated in Figure 1-(a) is given by

$$F_{dA_i-dA_j} = \frac{1}{\pi} (\cos \beta_i d\omega_j) = \frac{\cos \beta_i \cos \beta_j dA_j}{\pi r^2} \quad (1)$$

where $d\omega_j$ is the solid angle made by dA_j at the centroid of the area dA_i , $\cos \beta_j dA_j$ is the projection of dA_j normal to the radius vector r . Eq. 1 represents the fraction of hemispherical radiation leaving surface dA_i that is intercepted by the surface dA_j shown in Figure 1-(a). For a selected value of dA_j , the solid angle $d\omega_j$ subtended at the centroid of dA_i reduces as the square of the distance represented by the radius vector. This is of importance in the computer representation of this equation. By considering several such dA_j 's in the area A_j as shown in Figure 1-(b) the geometric viewfactor between the differential area dA_i and the finite area A_j is given by

$$F_{dA_i-A_j} = \int_{A_j} \frac{\cos \beta_i \cos \beta_j dA_j}{\pi r^2} \quad (2)$$

In computer programs the integration represented in Eq. 2 is replaced by the summation and the accuracy of the result depends on the individual size of dA_j 's and r the length of the radius vector. Similarly, by considering several dA_i 's as shown in Figure 1-(c), the total radiation view factor is given by

$$F_{ij} = F_{A_i-A_j} = \frac{1}{A_i} \int_{A_i} \int_{A_j} \frac{\cos \beta_i \cos \beta_j}{\pi r^2} dA_i dA_j \quad (3)$$

Again, it is possible to replace the double integration by the double summation in the computer programs, the accuracy of which depends on maintaining a typical small value of $d\omega_i$ defined in Eq. 1. This statement suggests that the choice of the sizes of dA_i and dA_j should be small when the distance between them is small, opposite being true when the distance is large in order to speed up computational time consistent with required accuracy. By multiplying Eq. 1 by dA_i the right hand side is rendered symmetric suggesting the reciprocity relation

$$dA_i F_{dA_i-dA_j} = dA_j F_{dA_j-dA_i} \quad (4)$$

Similarly from Eq. 2

$$dA_i F_{dA_i-A_j} = A_j F_{A_j-dA_i} \quad (5)$$

and from Eq. 3

$$A_i F_{ij} = A_j F_{ji} \quad (6)$$

³

Emission and reflection from such surfaces are perfectly diffuse obeying Lambert's Cosine Law

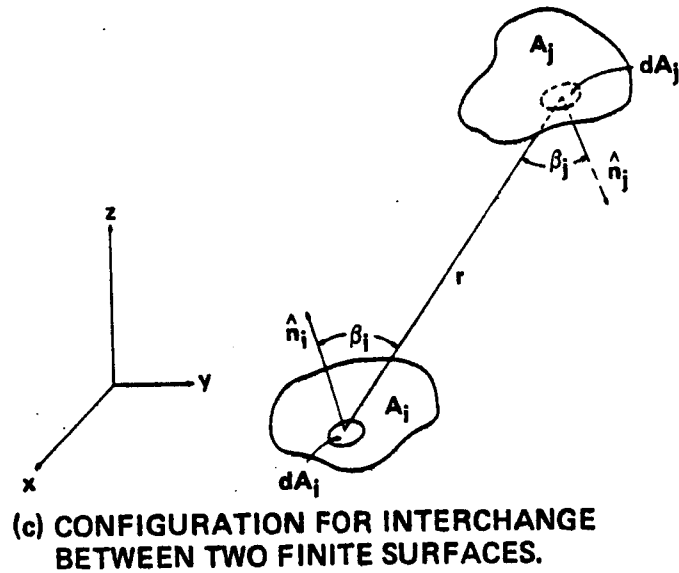
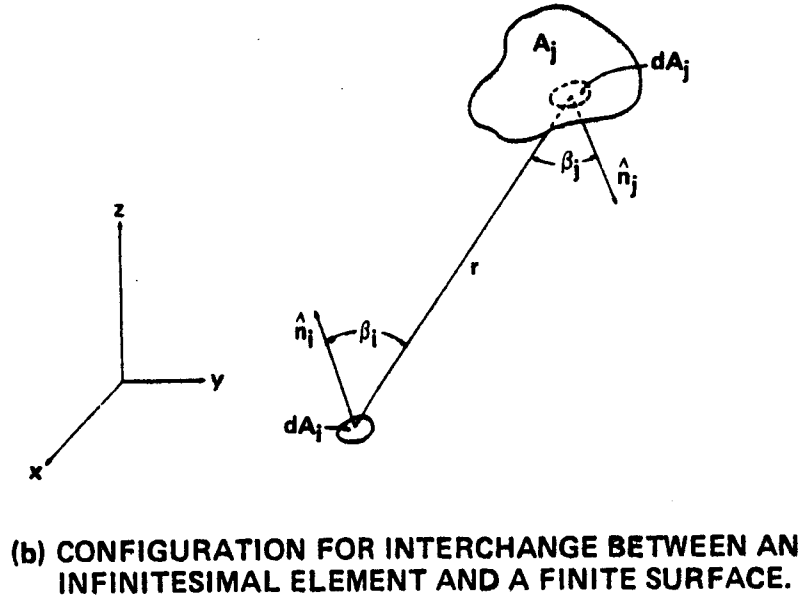
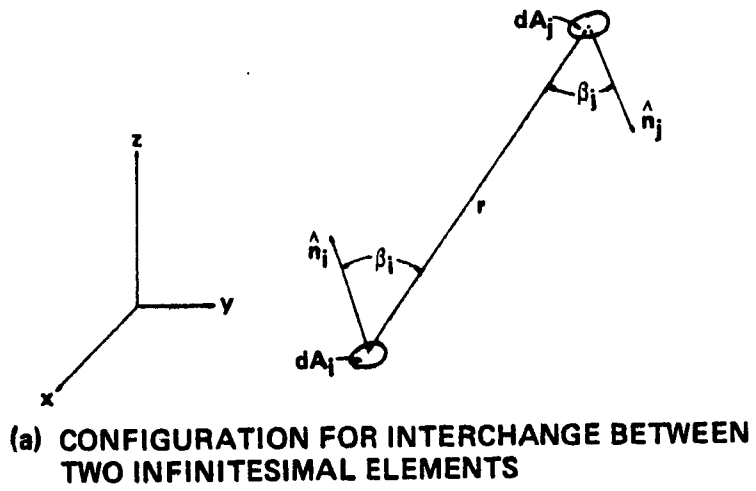

FIGURE 1 REPRESENTATION OF VIEW FACTOR

Equations 4, 5, and 6 represent useful reciprocity relations which can be utilized advantageously in computer program in order to reduce the time of computations. Equations 1, 2, and 3 and the associated reciprocity relationships are satisfactory for black bodies and gray surfaces. In the case of gray surfaces, the net energy transfer between two surfaces differential or finite is proportional to the radiation view factors. Here, the net energy transfer refers to the concept of radiosity⁴, that is the sum of diffusively emitted energy from the gray surface having an emissivity of ϵ and the fraction of diffusively reflected portion of incident energy from the same surface having a reflectivity of ρ . Here $\epsilon + \rho = 1.0$. However, the radiative heat fluxes need to be related to the characteristic temperatures of these diffuse surfaces.

Consider Fig. 2-(a). The radiosity $J_i = \epsilon_i W_{bi} + \rho_i H_i$ the sum of emitted energy from the diffuse gray surface (i) and reflected portion of the incident energy (H_i) from all the surfaces in view. Note $\epsilon_i + \rho_i = 1.0$. Similarly, $J_j = \epsilon_j W_{bj} + \rho_j H_j$. The net radiant flux leaving surface i is given by

$$q_{net,i}'' = J_i - H_i = \frac{\epsilon_i}{\rho_i} (W_{bi} - J_i) \quad (7)$$

Recognizing that the incident energy (H_i) is from the gray enclosure

$$H_i = \sum_{j=1}^N J_j F_{ij} \quad (8)$$

and

$$J_i = \epsilon_i W_{bi} + \rho_i \sum_{j=1}^N J_j F_{ij} \quad (9)$$

Equation 7 can be multiplied by A_i in order to obtain the total heat. Again, A_i can be replaced by dA_i , the sum by integration and F_{ij} by Eq. 1. This leads to integral equation of radiative exchange at the surface. For the case of two surface problems, that is, body and its enclosure (see Figure 2-(c), $F_{11} = 0$, $F_{12} = 1.0$)

$$q_{net,12}'' = \frac{W_{b1} - W_{b2}}{\frac{\rho_1}{\epsilon_1 A_1} + \frac{1}{A_1 F_{12}} + \frac{\rho_2}{\epsilon_2 A_2}} \quad (10)$$

which illustrates the electric resistance analog leading to network analysis. Recognizing $\epsilon_1 + \rho_1 = 1.0 = \epsilon_2 + \rho_2$, the radiant heat flux leaving surface 1 is

$$q_{net,12}'' = \frac{W_{b1} - W_{b2}}{\frac{1}{\epsilon_1} + \frac{A_1}{A_2} \left(\frac{1}{\epsilon_2} - 1 \right)} \quad (11)$$

Equation 10 can be generalized to represent the energy leaving gray surface A_i streaming towards another gray surface A_j

$$q_{net,ij}'' = \frac{W_{bi} - W_{bj}}{\frac{\rho_i}{\epsilon_i A_i} + \frac{1}{A_i F_{ij}} + \frac{\rho_j}{\epsilon_j A_j}} \quad (12)$$

$$q_{net,ij}'' = A_i F_{ij} (W_{bi} - W_{bj}) = A_i B_{ij} (W_{bi} - W_{bj}) \quad (13)$$

⁴
Hottel calls this term as "Leaving Flux Density" and suggests the word "Radiosity" as an undesirable word.

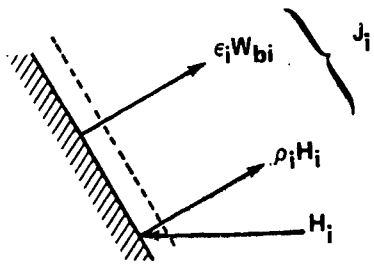

(a) NET RADIATIVE ENERGY TRANSFER AT THE SURFACE

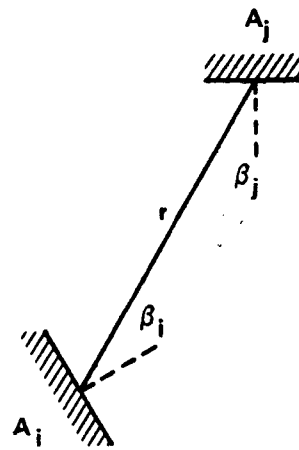

(b) RELATIONSHIP BETWEEN SURFACES

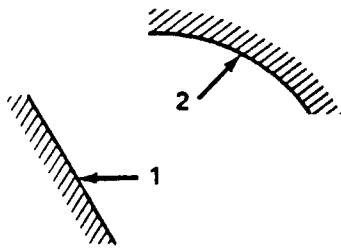

HERE $F_{12} < 1.0$

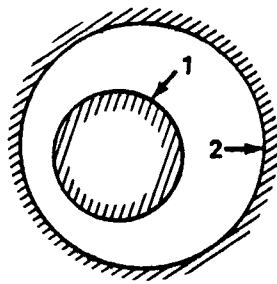

HERE $F_{12} = 1.0$

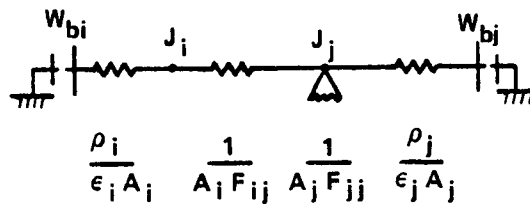

GENERAL CASE BETWEEN SURFACES A_i AND A_j

(c) TWO SURFACE PROBLEM – BODY AND ENCLOSURE OR SURFACES THAT CAN SEE EACH OTHER AND THE EQUIVALENT RESISTANCE ANALOGY

FIGURE 2. RADIOSITY AND RADIATIVE EXCHANGE BETWEEN SURFACES

Here, B_{ij} (F_{ij} often used in the textbooks) is the gray surface radiation view factor. For blackbodies $\epsilon_i = \epsilon_j = 1.0$ resulting in $B_{ij} = F_{ij}$, which is purely a geometric factor or configuration factor. A more general definition of patterned after Eq 3 is given by

$$B_{ij} = \frac{\int_{A_i} \int_{A_j} \frac{J_i}{\pi r^2} \cos \beta_i \cos \beta_j dA_i dA_j}{\int_{A_i} J_i dA_i} \quad (14)$$

and for the case of the radiosity being constant over the surface it will reduce to Eq. 3.

The concepts expressed in these equations are important. Various methods that are available to establish the geometric view factors and the associated gray surface will be reviewed in order to appreciate the speed and the accuracy of calculations in a complex enclosure such as the Space Laboratory. The concept of gray surface introduced here and its use instead of real surfaces need to be explained. They are as follows:

1. Each surface considered is isothermal. Here, it means that planar thermal conductivities are high. If a large surface cannot be treated as isothermal it is possible to subdivide the surface to smaller regions each assuring local isothermal conditions.

2. Each surface considered is gray. Here, it means that the emissivity and reflectivity are independent of the temperature, the wave length and they have no directional preferences in the hemispherical enclosure. It is possible to represent strong variation of property with respect to each of the quantities as step function with radiant energy transferred in each of this range. Real surfaces with selective coatings can be approximated in this manner provided the radiative properties are known to a reasonable accuracy and the increase in computational time can be justified. Specularly reflective surfaces can also be handled by the methods reviewed here. Chalk white surfaces have reasonably good diffuse reflectivity, although the tests have shown some specular character. It should be noted that the representation of variation in directional emissivity in the polar and azimuthal direction other than gray surface behavior will add considerable complexity increasing the computational time.

3. The radiosity of each surface is constant along the surface. This assumption makes the computed view factors independent of the magnitude and surface distribution of the radiant heat flux. It is clear that in order to validate this assumption the local isothermal condition of the surfaces should be assured and the incident radiant heat flux be the same at every point on the surface. Again, it is possible to subdivide the main surface in order to improve the accuracy and, hence, the complexity of computational procedure.

Further significances of these assumptions will be discussed later when the power of Monte Carlo method is compared to other numerical methods.

The basic concepts expressed in Figure 2 and Eq. 7 through 14 form the core for various numerical methods that are currently available. Here, the basis for the program development will be discussed.

Radiosity method, proposed by Eckert and Drake. The basic definition is set forth in Fig. 2-(a). From Fig. 2-(c), the heat flow is given by

$$q_i = (W_{bi} - J_i) / \left(\frac{\rho_i}{\epsilon_i A_i} \right) \quad (15)$$

Here q_i represents the heat flow leaving diffuse gray surface towards all parts of enclosure seen by it. This value of q_i need to be broken into n linear equations, solution of which depends on the emissive power of these surfaces which in turn related to the absolute temperatures via Stefan Boltzmann's Law, $W_b = \sigma T^4$.

Hottel's method. Here, the emphasis is placed on evaluation of net heat transfer q_{ij} between the two surfaces. As can be seen in Fig. 2-(c) it is the heat flow in the resistive element between J_i and J_j which is given by

$$q_i = A_i F_{ij} (J_i - J_j) \quad \text{and} \quad q_i = \sum_{j=1,0}^n q_{ij} \quad \text{Although the point of departure is different the calculations involved is same as the radiosity method.}$$

Gebhart's method. Here, the emphasis is on the net heat transfer from surface i to all the n surfaces of the enclosure each characterized by temperature

T_j 's. Adiabatic surfaces (re-radiating surfaces) are treated by substituting $\rho = 1.0, \epsilon = 0$ at these surfaces. The net heat transfer is expressed as difference between the emitted energy from surface A_i and that absorbed at n surfaces forming the enclosure which is given by

$$q_i = \epsilon_i A_i W_{bi} - \sum_{j=1,0}^n B_{ji} \epsilon_j A_j W_{bj} \quad (16)$$

Again $W_b = \sigma T^4$ and B_{ji} is the fraction of the energy emitted by surface j which is absorbed by the i th surface. Evaluation of the absorption factor B_{ji} involve the use of view factor, F_{ji} , the energy emitted and that reflected from the adjoining surfaces which requires all the other view factors of the enclosure. It is given by

$$B_{ji} = \epsilon_i F_{ji} + \sum_{k=1,0}^n \rho_k F_{jk} B_{ki} \quad (17)$$

Differences among the above three methods is in the viewing of the enclosure and the associated radiant exchange. As before, the calculations involved is the same as the previous two methods.

Oppenheim's Electric Network Analog method (1956)⁵. Figure 2-(c) represents such an analog between two gray surfaces.

Such a network can be constructed for an enclosure containing n surfaces. As before the adiabatic surfaces are treated by letting $\rho = 1$ and $\epsilon = 0$. Concave surface which can see itself will have a view factor as shown in Figure 2 -(C), but the net radiation is zero since the equivalent resistance $1/A_j F_{jj}$ is shorted out of the electric network. Radiation to outer space can be represented by treating it as black enclosure ($\rho = 0$) maintained at absolute zero which assures no returning of energy from that surface. The heat flow at any node i is represented by

$$q_i = \sum_{j=1,0}^n A_i F_{ij} (J_i - J_j) \quad (18)$$

and Eq. 7 relates q_i to the

⁵

See alphabetical listing of authors in references at the end of this report.

temperature of the i th surface. The unsteady state mode at one or more nodes can be represented by writing the applicable accumulation term. Such a representation permits use of widely understood Kirchoff rules of linear electric circuits. Because of the potentials of this body of knowledge, preference may be given to this method over the remaining three methods. The calculation procedures will not be much different and the results should be identical.

Greater details of the above four methods can be obtained from a paper by Sparrow (1963). All of these methods require radiation viewfactors, and solution to solving linear algebraic equations. The accuracy of the results depends on the extent to which gray surface approximations are valid. Only the overall heat transfer to and from the surfaces can be established. The uniformity of the heat flux depends on the extent to which local isothermal conditions over each surface is established. It is expected that in all but the simplest systems, the leaving radiant flux would likely to be nonuniformly distributed over a surface even if the surface is isothermal and exhibits the character of Lambertian surface. As stated earlier, each of the surfaces can be subdivided, the properties can be represented as step functions increasing the number of algebraic equations and complexity of the problem, and utilize the digital computers for their solutions. The success in reproducing actual result depends on the radiative property of the surfaces as a function of temperature and wave length and their directional character. Sparrow (1978) suggests monochromatic analysis for property dependence on wave length and integrating the results over the entire applicable range of wave lengths. This thought is same as step representation and the number of steps per surface should justify the concurrence between the predicted result and that of experience.

Radiation View Factor:

Nusselt Method.

Basic definition of the radiation view factor has been set forth in Figure 1 and Equations 1, 2 and 3. Such a representation is purely geometric in nature. Figure 3 further illustrates the definitions of view factors between the two differential areas dA_i and dA_j . Here, the total view from the center of dA_i is the "hemispherical space" above it in the viewing plane, which is termed as unity. An area A_j in Figure 3 projects a surface A_s on the hemisphere as viewed from dA_i . This surface is projected on to the base which is shown as A_b in Figure 3. The radius of the hemisphere being unity, the ratio of $A_b / \pi(1)^2$ is the geometric view factor $F_{dA_i-A_j}$ illustrated in the figure which is defined by Equation 2.

$$F_{dA_i-A_j} = \int_{A_j} \frac{\cos \beta_i \cos \beta_j}{\pi r^2} dA_j \quad (2)$$

This illustration forms a basis for explaining, experimentally determining, evaluating by digital computers and developing analytical solutions to the geometric view factor. It is the fraction of the total view. This type of

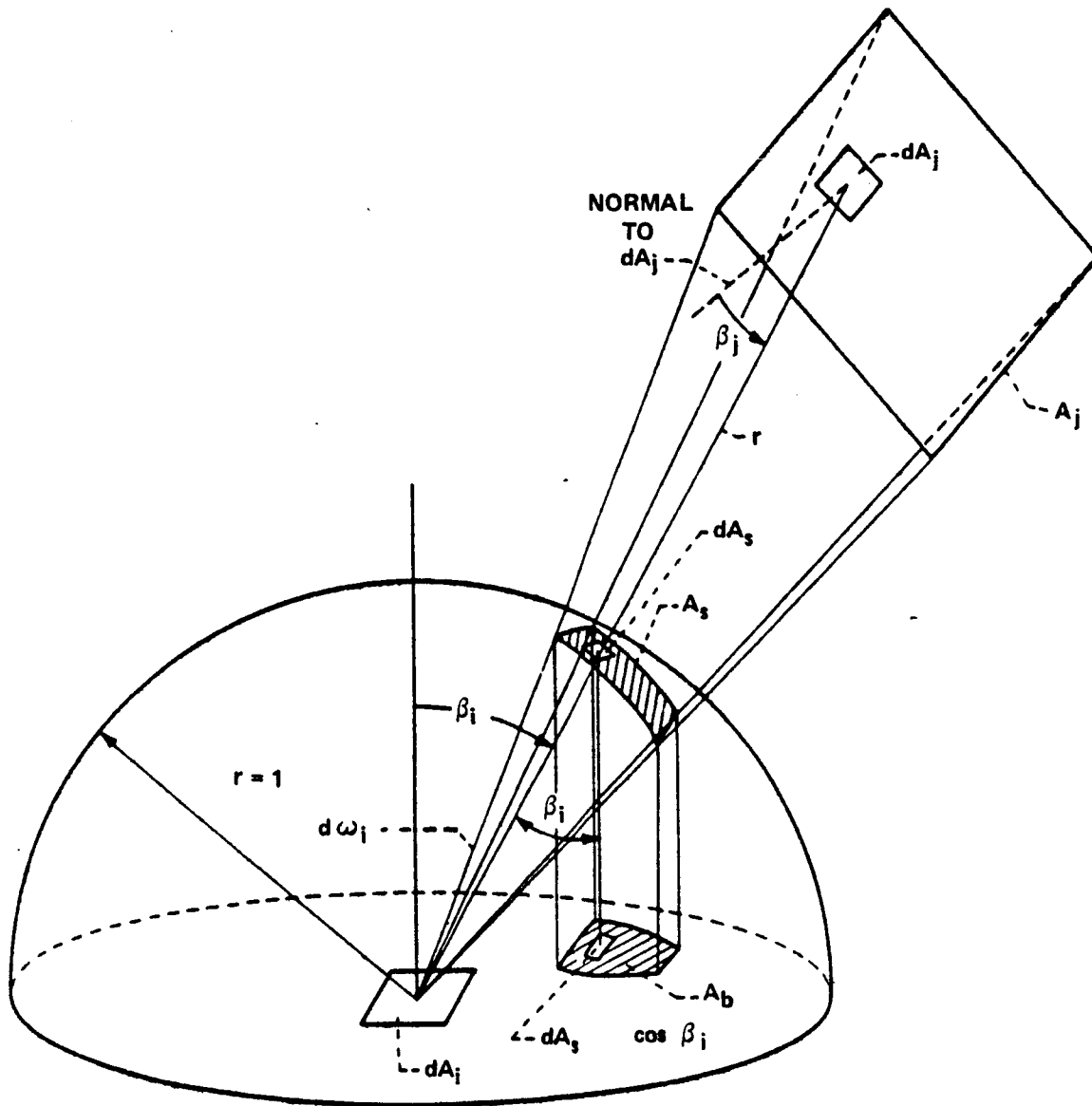

FIGURE 3 GEOMETRY OF UNIT-SPHERE METHOD FOR OBTAINING CONFIGURATION FACTORS.

representation is known as the "unit sphere method" first proposed by Herman (1900), and suggested again by Nusselt (1928). According to Jakob (1957) at almost the same time Seibert (1928) published a similar method. It is popularly known as Nusselt Unit Sphere Method. It is interesting to note why it was not called unit hemisphere method since the view range of the plane face dA_i is only the hemispherical space above it.

The view factor from the differential plane area dA_i should not be confused with the view experienced by a differential sphere of area dA_i to the enclosure. In this report, the space laboratory experiments in the payload bay are made up of plane, convex and concave surfaces for the determination of the view factors. In the case of the differential sphere having convex surface area dA_i the total view is the spherical space around it. Jakob (1957) shows that as a limiting case view factor of infinite plane with respect to this differential sphere is 1/2 while the view factor of the same infinite plane with respect to differential plane dA_i is unity. This result is easy to visualize. It requires two infinite planes to form a total enclosure around the differential sphere whose view factor will be unity. Same result will be obtained if both sides of the differential area dA_i are active viewing areas. In the determination of view factor only one side of plane or curved surfaces dA_i or ΔA_i is considered. It is important to note this subtlety since the determination of view factors from convex surfaces involve portions of differential areas not being able to see all of the viewing areas A_j , the receiving surface.

The illustration shown in Figure 3 has been the basis for experimental determination of the shape factor by mechanical integrators as developed by Hottel (1931), Hamilton and Morgan (1952) photographic technique proposed by Eckert (1935) Hickman (1961), photo electric method of England and Craft (1942), Jakob and Hawkins (1942) and electric analog developed by Paschke (1936).

Ray Tracing Technique.

The determination of the view factor as described here recognizes the fact that an infinite number of rays emigrate from a point in a plane in the hemispherical space above it. They are intercepted by adjoining surfaces forming a view (solid angle) with respect to the differential area at the source. Only those portions which can be seen are considered. If all the adjoining surfaces of the experiments in the payload bay, the sun, the earth and the planets as seen by the point do not cover the entire hemisphere the view factor of the remaining area is considered as view to the outer space. Farther is the area with respect to the viewing point smaller is its view factor. Such a ray tracing technique is the basis for determination of all view factor calculations whether it is closed form integration or numerical methods including Monte Carlo based model or experimental methods. In the numerical methods the viewing surface that is under consideration is divided into number of small areas ΔA_i . The view factor to each of the A_j forming the total hemispherical enclosure is estimated. These values of view factors for all ΔA_i forming the area A_i are weighted in order to assure the total view from A_i to all the surfaces A_j will not exceed unity. The accuracy of such numerical methods depend entirely on the sizes of ΔA_i and ΔA_j and the average distance between them as set forth in the definition given by Equation 1 and illustrated in Figure 1 -(a). The choice of the size of ΔA_j

depends on the distance r from ΔA_i and it should be selected in a manner that the typical value of $F_{\Delta A_i - \Delta A_j}$ is about the same small value during the entire field of calculations. This thought suggests that the sizes of ΔA 's should be progressively smaller if their average distances get smaller assuring the same level of accuracy. If the surfaces A_j and A_i have common boundary, the ΔA 's in their vicinity will be the regions for sources of error in the determination of view factors. If the determination of view factor to the space from a surface A_i is obtained by subtracting the sum of all the other view factors from unity, $1 - \sum_{j \neq i} F_{ij}$, it is only natural to expect sources of errors to propagate in the energy calculations and incorrect prediction of maximum and minimum temperatures of the surfaces forming the space laboratory experiments in the payload bay.

Double Integration - Double Summation Method.

The view factor between the surfaces A_i and A_j is given by solution to Equation 3. Here, the differential view factor given by Equation 1 is integrated once over the area A_i and next over the area A_j suggesting double area integration. Closed form solutions to a number of simple surfaces are available in the literature. Here, only two references will be mentioned, namely, NASA TN-2836 by Hamilton and Morgan (1952) and a recent textbook by Siegel and Howell (1981). In all these cases each area is defined by two parameters thus reducing the two area integrals to four line integrals.

For complex surfaces such as in the Space Laboratory mission the luxury of closed form solution is often unavailable resulting in replacing Equation 3 by double summation. Here, the area A_i and A_j are divided into small areas ΔA_i and ΔA_j and the differential view factors as expressed in Equation 1 is computed. First, the view factors over all of ΔA_j 's are summed, representing solution to Equation 2 and its weighted summation over all of ΔA_i 's represents solution to Equation 3. The areas A_i and A_j can be divided into small area in any convenient manner for digital computers and their centroid need to be located for determining the distance r between ΔA_i and ΔA_j as well as the associated differential view factor and weighting factor. The converging of the numerical value of F_{ij} as calculated by such a double summation method to a corresponding exact value that may be obtained from the closed form solution depends on the size of ΔA . Generally, as stated earlier, if the magnitude of the differential view factor is kept about the same small value by considering smaller ΔA as r decreases, there should be satisfactory convergence. It should be possible to compare the view factors F_{ij} 's as generated by the computer programs for the geometries for which closed form solutions are available and develop a level of intelligence for admitting variable sizes of ΔA thus reducing computational time consistent with accuracy.

Hottel's Stretch Film Method.

The surfaces and enclosures that exchange heat by thermal radiation such as in the payload bay of the Space Laboratory are plane, convex or concave surfaces. While any part of the plane or convex surface cannot see itself directly, the concave surface can see itself. In all cases, during the evaluation of view factors, if there are other surfaces partially obstructing the view all parts of surface 1 will not see all parts of surface 2 in order to determine the view factor F_{12} . Care should be exercised in evaluating such view factors

and avoid the possibility of over and/or under estimation of the energy exchange associated with them. Hottel (1954) provides solution to two dimensional cases and the methods is referred to as "crossed - string method". A variation of the same idea expressed by Hottel can be referred to as "stretch-film method".

In Figure 4 - (a1) the enclosure is made up of a complex surface A_1 , a plane surface A_2 and a convex surface A_3 , indicating that the real surfaces can be combination of such contours. The stretched string across A_1 will result in plano - convex surface A'_1 , ($A'_1 < A_1$), replacing the actual surface A_1 . In a three dimensional case the stretched string will be replaced by stretched film generating a cover everywhere there is concave contour very much like cellophane wrap. The shape factor relationship between the body (A_1) and the enclosure (A_2) is given by

$$A_1 F_{12} = A_1 (1 - F_{11}) = A'_1 \quad (19)$$

since $F_{11} + F_{12} = 1.0$ and $F_{1'2} = 1.0$.

Here, $F_{11} > 0$ since part of the surface can see itself. However, the view of the concave enclosure can only be through the stretched film covered over it. Utilizing the view factor algebra for the three surface problem the final expression is given by Hottel (1954) as

$$A_1 F_{12} = (A_1 + A_2 - A_3) / 2 \quad (20)$$

Figure 4 - (a2) represents a more complex enclosure containing areas A_1 and A_2 and bounded by other surfaces. The crossed - string BHGF and EJKL along with stretched - string BCDE and FGHJKL breaks the surfaces into problem represented by Figure 4 - (a1). It is also possible to represent the surfaces A_1, A_2 under consideration into A'_1 and A'_2 by stretched - string concept. By using Equation 20 Hottel has shown

$$A_1 F_{12} = (EJKL + BHGF) - (BCDE + FGHJKL) \quad (21)$$

from which F_{12} can be calculated. The right hand side of Equation 21 represents the length of the two crossed - string minus the length of the the two stretched - string between the two surfaces that are considered for the view factor. It should be possible to extend the method of Hottel for the two dimensional geometry to the three dimensional cases. In exploiting such a potential to its fullest extent it should be possible to generate stretched - film surfaces utilizing the geometry of the real surfaces and to break complex enclosure into simpler enclosure by introducing intermediate surfaces, resulting in the utilization of view factor algebra for further reduction in computational time without sacrificing the accuracy. Even if such a convenience cannot be exploited⁶ with the existing programs, the concept expressed in Equation 19, that is the energy crossing across A_1 , consisting of plano convex surface created by the stretched film is the same as that received by A_1 real surface consisting of plano - convexo - concave surfaces.

⁶

Reader is alerted to CAD programs with associated graphical displays which is capable of drawing various views very accurately which is mind boggling even for the best of living draftsman.

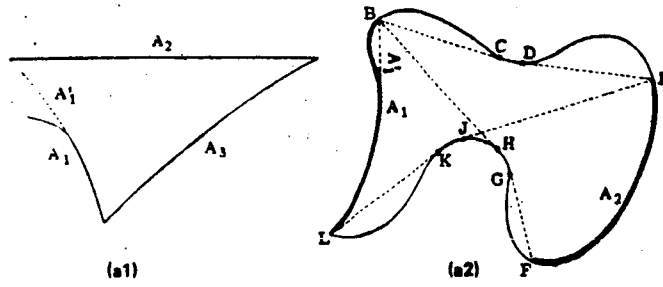

(a) TWO-DIMENSIONAL ENCLOSURES: (a1) THREE-SURFACE SYSTEM; (a2) ARBITRARY CONFIGURATION.

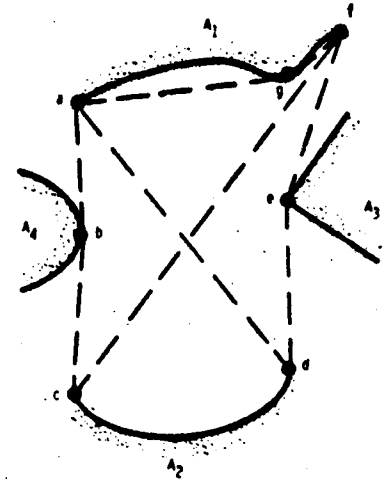

(b) VIEW BETWEEN ARBITRARY SURFACES WITH OPENINGS TO SPACE

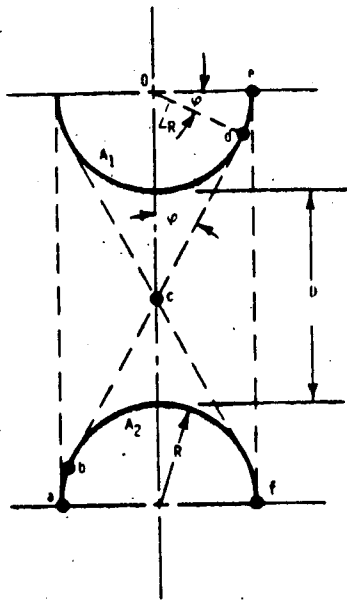

(c) VIEW BETWEEN TWO EQUAL AND PARALLEL CYLINDERS

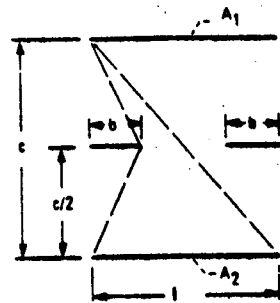

(d) PARTIALLY BLOCKED VIEW BETWEEN PARALLEL STRIPS

FIGURE 4 CROSSED STRING REPRESENTATIONS FOR TWO-DIMENSIONAL VIEW FACTORS

Figure 4 - (b) represents four real surfaces with spaces between any adjacent pair can be outer space or remote objects forming the enclosure. It is easy to visualize the payload bay of the Space Laboratory to contain such configurations. The shape factor relationship between A_1 and A_2 can be written as indicated in Equation 21 and by constructing a pair of crossed string and another pair of stretched string which in this case

$$A_1 F_{12} = \frac{(A_{cf} + A_{ad}) - (A_{abc} + A_{fed})}{2} \quad (22)$$

which is same as Equation 21.

Figure 4 - c represents two cylinders of equal radius having their axes parallel to each other and a minimum separation of D . It is desired to express the mutual view factor. Note that the halves of the cylinders not seen by each other are not shown in the figure. The pair of crossed string $abcde$ and the pair of the stretched string fe are also shown. Defining $X = [1 + (D/2R)]$ and utilizing Equation 21.

$$F_{12} = \frac{2}{\pi} \left[(X^2 - 1)^{1/2} + \frac{\pi}{2} - \cos^{-1}(1/X) - X \right] \quad (23)$$

An extension of Equation 23 for the case of cylinders of unequal radii, R_1 , R_2 ($R_1 > R_2$) and their axes separated by a distance C is given by

$$F_{12} = \frac{1}{\pi R_1} \left\{ R_1 \phi_1 + R_2 \phi_2 + [C^2 - (R_1 + R_2)^2]^{1/2} - [C^2 - (R_1 - R_2)^2]^{1/2} \right\} \quad (24)$$

Where $\phi_1 = \alpha - \beta$, $\phi_2 = \alpha + \beta$, $\alpha = \sin^{-1}(\frac{R_1 + R_2}{C})$, $\beta = \sin^{-1}(\frac{R_1 - R_2}{C})$

For the case $R_1 = R_2$

$$F_{12} = \frac{2}{\pi} \left[(X^2 - 1)^{1/2} + \sin^{-1}(1/X) - X \right]$$

which is same as Equation 23 since $\pi/2 - \cos^{-1}(1/X) = \sin^{-1}(1/X)$ (23)

Figure 4 - (d) represents the view factor between infinite strips A_1 and A_2 in the presence of two other infinite strips forming a slit. The Hottel's crossed-string method yields (see Siegel and Howell (1981)).

$$F_{12} = \frac{1}{\ell} \left\{ [l^2 + c^2]^{1/2} - 2 [b^2 + (c/2)^2]^{1/2} \right\} \quad (25)$$

The results of Equations 23, 24 and 25 can be checked with TRASYS program for speed and accuracy of the computations resulting in required shape factors.

Contour Integration Method

Determination of the view factor $F_{dA_i - A_j}$ using Equation 2, involves two line integrals while F_{ij} using Equation 3, involves four line integrals. In the contour integration method they can be reduced to one and two line integrals respectively. Here, the line corresponds to the boundary of the areas A_j and A_i thus acquiring the name contour integral. Such a transformation is due to Theorem of Stokes. The method is applicable for a piecewise smooth oriented

surface in space and its boundary be a piecewise simple closed curve. The integration around the closed curve is taken in a manner such that the interior space is to the left of a person walking on the edge of the contour with his head pointing in the same direction as the unit normal. According to Stokes Theorem⁷

$$\oint_C P dx + Q dy + R dz = \int_A \left[l \left(\frac{\partial R}{\partial y} - \frac{\partial Q}{\partial z} \right) + m \left(\frac{\partial P}{\partial z} - \frac{\partial R}{\partial x} \right) + n \left(\frac{\partial Q}{\partial x} - \frac{\partial P}{\partial y} \right) \right] dA \quad (26)$$

where P, Q and R are each functions of x, y and z and they are twice differentiable function and l, m and n are direction cosines of the area dA .

Details of contour integration method can be found in the book of Sparrow and Cess (1978). Here, some pertinent details will be given. In Figure 1 - (b)

$$r^2 = (x_i - x_j)^2 + (y_i - y_j)^2 + (z_i - z_j)^2$$

$$\cos \beta_i = \frac{1}{r} [l_i (x_j - x_i) + m_i (y_j - y_i) + n_i (z_j - z_i)]$$

$$\cos \beta_j = \frac{1}{r} [l_j (x_i - x_j) + m_j (y_i - y_j) + n_j (z_i - z_j)]$$

and using in Equation 2

$$F_{dA_i - A_j} = \int_{A_j} \left\{ l_j [(x_i - x_j)f] + m_j [(y_i - y_j)f] + n_j [(z_i - z_j)F] \right\} dA_j \quad (27)$$

$$\text{and } f = \frac{1}{\pi r^2} [l_i (x_j - x_i) + m_i (y_j - y_i) + n_i (z_j - z_i)]$$

Equation 27 represents the right hand side of Equation 26 setting the stage for the application of Stokes Theorem. Now

$$F_{dA_i - A_j} = l_i \oint_{C_j} \frac{(z_j - z_i) dy_j - (y_j - y_i) dz_j}{2 \pi r^2} + m_i \oint_{C_j} \frac{(x_j - x_i) dz_j - (z_j - z_i) dx_j}{2 \pi r^2} + n_i \oint_{C_j} \frac{(y_j - y_i) dx_j - (x_j - x_i) dy_j}{2 \pi r^2} \quad (28)$$

In practice, in order to simplify the integration where possible select coordinate axes such that one of them is in the same direction as the unit normal of dA_i . Such a choice permits evaluation of only one of the three parts in Equation 28, the other two being zero since the direction cosines are zero. If one or two coordinates of C_j are constant additional simplification of Equation 28 will result. For a complex geometry such a simplification may not be available.

In Equation 28 each of the contour integral can be evaluated independently. The results represents view factor of the surface A_j with respect to three mutually perpendicular dA_i at location i whose normals are coincident with respect to l_i, m_i and n_i . In particular, the absolute value of first part of Equation 28 is for the case $l_i = \pm 1, m_i = n_i = 0$. Both signs of l_i are applicable, they depend on normal to the element along $+x$ or $-x$ axis as it views A_j . Moreover, it is possible that $l_i = +1, m_i = n_i = 0$ may see a portion of A_j and $l_i = -1, m_i = n_i = 0$ may see the remaining portion of A_j such as in the wrap around case. In such cases the contour integral is sum of the two view factors, thus

$$\left| \oint_{C_j} \frac{(z_j - z_i) dy_j - (y_j - y_i) dz_j}{2 \pi r} \right| = F_{dA_i - A_j} (\pm 1, 0, 0) \quad (29)$$

Theorem of Gauss converts volume integral to area integral, area being the bounding surface of the volume itself.

Similarly other two parts of Equation 28 can be computed and identified as

$$F_{dA_i - A_j}(0, \pm 1, 0) \quad \text{and} \quad F_{dA_i - A_j}(0, 0, \pm 1)$$

Finally, the required view factor from dA_i having direction cosines, (ℓ_i, m_i, n_i) is

$$F_{dA_i - A_j} = |\ell_i| F_{dA_i - A_j}(\pm 1, 0, 0) + |m_i| F_{dA_i - A_j}(0, \pm 1, 0) + |n_i| F_{dA_i - A_j}(0, 0, \pm 1) \quad (30)$$

Equation 30 suggests principle of superposition of the view factor. It can be utilized to convert view factor evaluated along the principle axes to any orientation by rotation (vector sum). Such considerations may avoid repetitive calculations besides the advantage of single integration replacing double integration.

Sparrow and Cess (1978) shows that the Stokes Theorem can be applied twice in order to evaluate F_{ij} . The final form of the expression is

$$F_{ij} = \frac{1}{2\pi A_i} \oint_{C_i} \oint_{C_j} (\ell_n r dx_i dx_j + m_n r dy_i dy_j + n_n r dz_i dz_j) \quad (31)$$

where

$$r^2 = (x_i - x_j)^2 + (y_i - y_j)^2 + (z_i - z_j)^2$$

Equation 28 or Equation 31 can be used. Here, four line integrals traversing entire surface A_i, A_j have been replaced by two line integrals traversing around the contour of A_i, A_j . The closed form integration of Equation 31 is possible for simple shapes. For complex surfaces the integration is replaced by summation and it is more advantageous for computers.

Monte Carlo Method.

Radiative exchange rates at a location is a function of local temperature and energy fluxes that are coming in or going out. This energy can be represented by discrete amounts (bundles) say N , typically of the order of 10,000 emitted from a point in all directions. Accuracy of the method increases with increasing values of N . By assigning energy level to each bundle the total heat flux at the point is satisfied. The Monte Carlo method derives its name from the fact that the laws of probability (chance) are employed in determining the direction of travel of energy bundles and in deciding if a bundle is absorbed, reflected or escapes into space. Some of the other names are "Random Walk" and Markov Chain. The probability of energy bundle leaving a location in a given direction expressed in spherical angles (polar and azimuth) arriving at another location is estimated. This bundle path history is computed by Monte Carlo method. The energy reflected back from the receiving location to the source and then back to receiver is neglected. The accuracy of the method depends on perfect randomness of the process.

Directional distribution of emittance as well as the spectral variations can also be considered. The distribution functions are normalized to give values from 0 to 1. The probability functions for diffusively emitting surfaces are $R_\theta = \sin^2 \theta$ ($0 \leq \theta \leq \pi/2$), $R_\phi = \phi/2\pi$ ($0 \leq \phi \leq 2\pi$) and equal energy is assigned to each bundle. Similar probability functions R_θ, R_ϕ for surfaces having different radiation properties need to be established if the surfaces are not gray. A pair of random numbers R_θ, R_ϕ specifies the direction of departure θ, ϕ of the

energy bundle having a certain magnitude towards the configuration of the enclosure. Its point of impingement on the receiving surface is determined. If the receiving surface has absorptivity α (or $\alpha_{\lambda, \phi}$) a random number R_{α} ($0 \leq R_{\alpha} \leq 1$) is drawn. If the range of α is $0 \leq R_{\alpha} \leq \alpha$ the incident bundle is assumed to be absorbed and it is recorded. The process is repeated for all bundles. If all surfaces are gray the same probability functions can be repeatedly used. In this case, the result of Monte Carlo method is geometric view factor as expressed in Equation 2 since the process is completed for a point on the emitter ΔA_i , to the receiver A_j . The process is repeated for every location of the emitter A_i represented by ΔA_i in order to determine the view factor F_{ij} .

The method described here suggests that the bundle originating from a point not intercepted by any of the surfaces forming the surfaces of payload bay, the sun, the earth can also be recorded. Hence, it should be possible to directly evaluate the view factor of a surface to the sprawling space. The accuracy of estimation of all view factors are upgraded by considering larger values for N suggesting the use of high speed digital computers with large storage capacity. More recent developments of the use of Monte Carlo method for radiation exchange incorporate the time saving schemes by selectively using scaling functions for the probability functions and completing the calculation only when the random numbers R_{θ} and R_{ϕ} impinges on the required surface. As stated earlier, the variation of the radiative properties can easily be accommodated when such information is made available without disturbing the methodology of Monte Carlo procedure.

In the calculation of the view factor, each selected point views the hemispherical space above it (in the direction of unit normal). Since the pair of random numbers R_{θ} and R_{ϕ} selected for each bundle has to intersect either any of the surfaces of interest or not intersect at all (lost to outer space) it should be possible to record all the information and evaluate simultaneously all the radiation view factors from the differential area selected. For a pictorial view of the above statement Figure 3 may be considered. Each of the A_j will create an island A_s on the unit hemisphere with A_b being projection on its base. The sprawling space around the groups of islands obviously represents the shape factor F_{dA_i} space when this area is projected on to the base of the hemisphere. Potential of this procedure should be exploited.

Comparison of Other Methods with Monte Carlo Method

Formulation of equations for radiant exchange by methods other than Monte Carlo method results in integral equation. Correspondingly, the accurate determination of the view factor results in double area integration. Closed form solution can only be obtained for single viewing surfaces. Nusselt Unit Sphere Method is suitable for view factor from a differential (small) area to a finite (large) area. Contour integration reduces the difficulty of double area integration to an extent. The difficulty of all these methods when applied to complex surface is a consequence of 'macroscopic' view point when deriving either the radiant exchange of the view factor to a receiving surface. On the other

hand the use of probabilistic model and Monte Carlo sampling techniques reduces the problem to "semi macroscopic or semi microscopic" depending on the size of N and avoids many of the difficulties inherent in the averaging process of the integral equation formulations. Monte Carlo provides a basis to examine the small parts of the total energy on an individual basis and accumulate the results instead of making an attempt to solve simultaneously the entire behavior of all the energy involved.

The complexity involved in Monte Carlo method is roughly proportional to the complexity of the problem. In all other cases amenable to numerical methods the complexity grows rather rapidly. The closed form solutions for view factors are available only for simple shapes. The complexity of formulation by Monte Carlo method for simple shapes and associated computational time to obtain the numerical result via digital computers makes the procedures undesirable. However, these examples can be used to check on the applicability of the method and its speed and accuracy. As the complexity increases it may be the only method for speed and accuracy of determination of the view factors or energy exchange between real surfaces. The availability of radiative property information is best utilized in Monte Carlo method. The choice of the use of the Monte Carlo method over any one of the other methods and their relative accuracies should be established by running test cases in the available high speed computers. Potential of improvisation to the existing Monte Carlo methods and hybrid situation should not be overlooked.

The determination of view factors and their use in radiative energy exchange involve assumptions such as the surfaces are diffuse - gray emitters and reflectors, they are locally isothermal and the total flux arriving at the surface is evenly distributed across the entire area. In real problems such as in payload bay of the Space Laboratory, the validity of any of these assumptions may be poor. In such cases, the calculation of view factor becomes difficult and their use in energy calculation will not give accurate results. In such cases, and when the geometry of surfaces are nonplanar, Monte Carlo technique may be invaluable. Parametric studies may resolve the issues that are raised here. Potential of the use of Monte Carlo technique to compute radiative heat - transfer directly as against using Monte Carlo technique for the evaluation of view factor and then using auxiliary program for the radiative heat transfer should be explored. Use of Monte Carlo method provides direct answer to the radiative heat fluxes between two surfaces of interest with no restrictions to the variation of surface property characteristics thus bypassing the calculation of radiative view factors. Inability to describe the surface properties will reduce the problem to simpler cases without any loss of generality that will be available for later use when data is made available. Additional details of the method can be obtained by reviewing the references by Howell (1968), Siegel and Howell (1981), Edwards (1981), Sparrow and Cess (1978).

Turner, Humphries, and Littles (1981) have compared results obtained by Monte Carlo method with specialized ray tracing technique and the TRASYS II program when applied to specularly reflecting surface of orbiter door of the payload bay in its open position to the incoming beam of solar radiation. The curved surface have been represented by small planar segments in order to utilize the composite limitations of the programs selected.

One hundred percent specularly reflecting surfaces for the interior of the orbiter door has been considered for comparison. Monte Carlo method accommodates multiple bounce while the specialized ray tracing technique is restricted to single bounce. The pattern of local heat flux variations on the surface of the payload bay compares favorably between the two methods. The total heat flux rate evaluated from the local heating rates compared very well with that obtained by TRASYS II program which allow consideration of specular surfaces. The discontinuities caused by replacing continuous surface by planar segments can be considered by offsetting planar nodes over small increments and changing its orientation accordingly and study the pattern of absorbed heat rate on receiving surface after the reflection from the interior of orbiter door. They can also be compared to smaller segment results. In reality, the existence of planar conduction of the receiving surfaces will naturally smooth out the variations in the heating rates obtained in this paper comparing more favorably with the total heat flux rate.

Numerical Procedures:

The temperature and the radiant heat flux at a point on the surface of any part of the Space Laboratory depends on the conduction heat transfer influenced by internal heat development and/or internal cooling, the diffuse/specular radiative properties at the surface, the radiant fluxes imposed by external sources, the heat exchange among the viewing surfaces and the heat loss to the outer space. Such a consideration for a differential area around the point results in integral equation. The formulation of problem utilizes radiosity concepts which in turn, requires the unknown temperature distribution. The interplay of the radiant energy requires differential view factors. The conduction part related to the first power of temperature and the radiation part related to the fourth power of temperature renders the equations to be nonlinear. It is important to note that the variation of temperature and radiosity over the surface necessitates area integral ruling out the use of contour integral in order to seek the required solution. Thus, the computational efforts are increased enormously if the heat balance of the Space Laboratory equipment in the presence of conductive/radiative environment need to be considered accurately. Replacing real surfaces with gray surface and recognizing large areas of the enclosure to be isothermal reduces computational time greatly. They permit evaluation of radiation view factors, their use in the radiative heat exchange and in the thermal analysis problem providing a means to decouple the problem. Even with this simplification, the computational time for the evaluation of view factors and the associated thermal analysis is considered excessive in the Space Laboratory configuration. The accuracy of the results also need to be established.

Iterative Procedure.

Initial distribution of radiosity is assigned using the radiation exchange formulation between a selected location x_0 and a general location x , a new value of radiosity at x_0 is calculated. Such a numerical procedure is repeated using the updated values of radiosities where available and old values at other locations. The process is repeated until the required convergence at all locations are satisfied. For problems where the nodal radiation is uncoupled with the nodal conduction, the iteration procedure will generally converge without problems of instability. Here, the radiant exchange will be

a linear function of radiosity permitting resistance network analogy leading to algebraic system of equations. With nodal conduction, the nonlinear coupling may display oscillating behavior for successive iterations or even exhibit diverging characteristics. In such cases the consideration may be given to replace the newly computed radiosity with the weighted average of the old and the new values at the same location.

Finite Difference Procedure.

The radiative exchange between any two points represented by integral equation is replaced by a finite sum of terms by dividing the areas to smaller areas, the points located at the centroid of these areas and the radiosity assumed constant over this elemental surface, itself being assumed to be isothermal. The accuracy of the finite difference scheme is comparable to numerical integration by trapezoidal rule, which can be improved by considering smaller element sizes. For the case when radiation is uncoupled with conduction, a number of powerful assortment of techniques are available for the resulting linear algebraic equations. These are standard techniques in the high speed digital computers. It should be expected that the solution to the radiative exchange using finite - difference technique could be carried out over a shorter time when compared to iterative method. In this finite - difference method care should be taken to minimize the loss of accuracy of the final results by insuring against the loss of significant figures associated with solution to the system of linear algebraic equations. Inclusion of nodal conduction to the volume bounded by the elemental area results in nonlinear algebraic equations. Techniques are available for such problems, but they may not be in the form of readily available standard subroutines to the computer programs.

Finite Element Procedure.

The thermal analysis of the complex structures used in the space platform is to predict temperature excursion under varying thermal environment experienced during orbit under various orientations. It will cause thermal stresses which may need to be incorporated at the design stage of these structures. A fast and compatible solution is to break the structures into such elements which can be used in both the thermal and the stress analyses, of which thermal stress is but one part. Finite element method is most popular in the field of stress analysis. Historically, it has replaced the previous finite difference method which is cumbersome because of the odd shapes and contours of the structures. It is natural to expect that the corresponding thermal problem use the same finite element technique in order to make the solution interactive at all stages. Since the finite element structure required for the solution follow the contour of the surface itself, the irregular geometry can be easily accommodated. In the finite difference method these areas are represented by irregular nodes. Emery and Mortazavi (1981) make an excellent comparison of finite difference and finite element methods for the heat transfer calculations. Other useful references for basic aspects of these two methods are the books by Myers (1971) and Chung (1978).

Solution by finite element method requires three new concepts, namely, minimization of a function having one or more variables, calculus of variation laying foundation to this method and the approximation of integrals, besides the representation of derivatives with a finite difference as used in the older finite difference method. Here, the nodal points are ends of the triangular element in contrast to the centroid of the rectangular element in the finite difference scheme. Rest of the computational steps are the same for both the methods. In the finite element method the compatibility of the temperatures at the node of the two elements is assured but not the continuity of the heat flux at these nodes. In finite difference method the continuity of heat flux at the node is also assured. Such a lack of continuity of heat flux in the finite element method causes oscillatory character at the nodes with overshoot at one node compensated by undershoot at an adjoining node. In current computer programs, the automatic mesh generators are available for the finite element method. For a more detailed comparison of the two methods, the reference is made to the paper by Emery and Mortazavi (1981) which also contain relative execution time for same problems. Some of the other points covered by them are assemblage of the global matrix, boundary conditions and irregular meshes and graphical display of results. The comparative examples considered by them are distributed and concentrated heat sources, transient temperatures in one and two dimensions, problems containing singular points, thermal radiation problems and transient phase changes.

The finite difference method is best suited when the boundary conditions are to be treated with high order accurate schemes, for highly nonlinear problems for which iterative solutions are efficient, for problems in which the continuity of the heat flux is important and multi-dimensional problems involving change of phase. The finite element method is best suited for irregular regions for which the automatic mesh generation and highly accurate modeling exists resulting in good temperature profiles, for mildly nonlinear problems requiring a very few iterations, for problems requiring graphical display, for problems involving singular temperature points and concentrated heat sources, for problems in which different approximations are used in different regions and they need to be joined together and problems in which temperature profiles are desired.

Approximate Analytical Solution.

The net radiant interchange from a point in the enclosure results in integral equation since the reflected portion of the energy is a function of incoming radiosity from all points in the enclosure to the point under consideration. If one were to include the conduction into or out of the differential surface area of the body at the point, the resulting representation is integro-differential equation. In general, the close form solution of such an accurate representation of the equation is difficult even though it is desirable. Under certain conditions when the kernel of the integral equation can be approximated by another manageable function it is possible to obtain approximate analytical solution. The choice of this new function should represent the kernel as closely as possible, it should be a differentiable function and some order of its derivative be proportional to the function itself. With such requirements satisfied, it is possible to

reduce the integral equation into a differential equation increasing the possibility of closed form solution. When the kernel can be represented by simple elementary function exact solution is possible. Methods of calculus of variations to represent the kernel results in appropriate solutions which can be made highly accurate. The complexity of the Space Laboratory configuration prevents one to pursue this method. However, when such situation exists the closed form solutions is the simplest and most accurate without any computational time involved.

Monte Carlo Procedure:

It has been stated earlier that Monte Carlo method is best suited for radiation problems in which directional variations, polarization, specular and diffuse characteristics of surfaces and other complicating factors need to be considered. While such relaxation of assumptions permits the solution to be carried out with only slight additional complexity and increased computational time the other procedures fail to generate the required solution. Such an advantage can be compared to potential flow solutions which is governed by Laplace differential equation. The closed form analytical solutions for potential flow can be generated for simple geometries. However, having demonstrated that the potential and flow lines should always intersect everywhere at right angles as represented by Cauchy-Riemann relationships, it is a simple matter to draw such lines for a complex geometry and obtain the heat flow characteristics (conduction shape factors) using the method of curvilinear squares (rectangles). Here too, a method is available to solve practical problem approximately when analytical methods fail and finite difference/finite element methods add degree of complexity for the irregularly shaped bodies. As in this case and in using Monte Carlo method for radiative heat transfer characteristics, the solutions for known cases by the more exact procedures can be compared to the newer techniques for accuracies. The confidence gained in the execution of the procedures and the comparison of the results will aid in the efficient development of procedures for complex situations mentioned here as well as reducing the computational time.

The Monte Carlo procedure utilizes simplified, computerized statistical approach to ray tracing. The radiative properties at the surface suggests the fractions of energy absorbed, emitted, reflected and perhaps transmitted. when the incident energy strikes the surface. The Monte Carlo algorithm compares a random number within the range of probabilities to the theoretical fractions and assigns the whole incident flux to the reflected or absorbed or transmitted wave. Another random number compares with the reflected or emitted flux leaving a point selected randomly in the known surface has arrived at the required surface and assigns this flux. A large number of such samples are considered in order to make the statistical fraction between 0 to 1.0 converge to the expected answers. The Monte Carlo algorithm avoids branching during a ray tracing procedure. Here, the energy is not both reflected and transmitted, instead, it is either reflected or transmitted and one result is traced further till extinction. Similarly, the energy leaving a point either strikes the surface or not arrive at all. One of the two results is counted. The procedure suggests that the surface properties can be recognized by selecting energy level, the surfaces can be combination of plano - convexo - concave orientations, the surfaces can be specular or reflective and the absorptivity/emissivity ratio can be as desired.

The method is ideally suited for directly computing the radiative exchange in real situations, the gray body view factors for diffuse surfaces or in the degenerated case of blackbodies the view factor between surfaces. Modest and Poon (1977), and Modest (1978) have applied Monte Carlo procedure for the determination of radiative exchange heat flux at the deep v-shaped cavity of the opened payload bay doors of the Space Shuttle which was suspected to have potential hot spot. This problem reflects all the complexities stated here and the potential of this procedure is equally applicable for future exposed orbiting equipment such as in Orbiting Space Station. Because of the immediate application of their work to the current problem, it should be illuminating to read their remarks and comparison of the procedure with the experimental result.

Consider a complex enclosure made out of n surfaces and opening to outer space. For the sake of simplicity consider each surface to be isothermal and they exhibit diffuse radiative properties. The view of the Sun and Earth through this sprawling opening can also be treated as surfaces. Thus, there are $n + 3$ surface forming the total enclosure. The net heat balance among the i th surface, the remaining enclosure with n surfaces, the Sun, the Earth and the outer space may be written as

$$q_i = \epsilon_i A_i W_{bi} - \sum_{j=1}^n \epsilon_j A_j W_{bj} - q_s'' A_{os} B_{si} - q_E'' A_{oE} B_{Ei} \quad (32)$$

where A_{os} , A_{oE} are the areas at the sprawling opening covered by the Sun and the Earth as viewed by the surface A_i respectively, and q_s'' , q_E'' are corresponding heat fluxes penetrating towards the surface A_i and the remaining term representing the emitted energy at each of the n surfaces as represented in Equation 16. Here, that portion of emitted energy from the surface A_i lost through the opening not covered by the Sun and the Earth ($n + 3$ rd surface) is lost to the outer space. Each of the terms on the right hand side of Equation 32 can be replaced by heat flow from real surfaces which can be directly calculated by Monte Carlo method. Thus, there is no loss of generality. Here, each of the quantities is proportional to the diffuse radiation view factor B_{ij} or B_{ji} or B_{si} or B_{Ei} . In the Monte Carlo procedure, the statistical sample of energy bundles N_i emitted from the surface A_i is considered. The probabilistic history of N_{ij} bundles being absorbed by the surface A_j either after direct travel or after any number of reflections (for the case $\alpha < 1.0$) is accounted by this procedure. For the case of gray surfaces the final result is

$$B_{ij} = \lim_{N_i \rightarrow \infty} (N_{ij}/N_i) \approx (N_{ij}/N_i) \quad N_i \gg 1.0 \quad (33)$$

For the more general case the right hand side of Equation 33 is modified to directly give the net energy leaving the i th surface and received at the j th surface. The accuracy of the results obtained by this procedure depends on the large numbers of energy bundles selected, its directional and spectral characteristics properly represented and the path traced in arriving at the energy absorbed at the surface (general case), the diffuse radiation view factor (gray surface) and the geometric view factor (blackbodies) being special cases.

The Monte Carlo procedure indicated here suggests that the accuracy of the results depends on the large number of samples considered. The convergence to the true values may be oscillatory. It requires the aid of high speed digital computers with large memory space. Smaller the value of the view factor larger will be the number of energy bundles required to achieve the same level of accuracy. This number increases with each additional parameter required to describe the characteristic of the energy bundle but it will always produce the result to sufficient level of accuracy while the other methods fail to converge on the required answer.

Hybrid program using Monte Carlo procedure to obtain directly the energy absorption/emission characteristics of the exposed orbiting equipment should be preferred to the Monte Carlo program which generates partial information (say view factor) required as an input by another energy analysis program. Here, it is not recommended to use Monte Carlo program to replace TRASYS program only followed by SINDA program, although such an option can be exercised by the developers, and the users of the computer programs.

The Monte Carlo procedure indicated here suggests the possibility of calculating the energy interchanges among $n + 3$ surfaces simultaneously. In the space applications such as in the exposed orbiting equipment, all the information is needed. The time required for this total information is not much more than that required to calculate the energy exchange between the i th and j th surfaces. The reason for this thought is as follows. Having randomly selected the level and characteristic of each energy bundle leaving a point on a surface in a direction, it has to arrive at some point on one of the $n + 3$ surfaces whose absorbing reflecting characteristics are known. The history of the energy level of this originating bundle is traced till its near total extinction takes place as it strikes different points of $n + 3$ surfaces and this information can be stored. This procedure is repeated for all the bundles selected. The stored values for each of the surfaces is the required answer. Again the accuracy depends on the number of the bundles. Selected for each location whose total value represents the energy level. The computational time required for this approach by Monte Carlo procedure is considerably shorter than selecting the surfaces i and j and accumulate the hits or misses of the moving energy bundle in the total enclosure one at a time. According to Edwards (1981) the basic elements of Monte Carlo procedures are randomly choosing a location of emission, choosing a direction of emission, tracing a ray to a wall and determining its node number, deciding whether the ray is absorbed or reflected (or transmitted), choosing the direction of reflection (or transportation) and scoring increments of transfer factor. The number of strikes (arrived at the j th surface) compared to the number of starts (departure from the i th surface) is the expected result, that is, view factor, F_{ij} diffuse radiation factor, B_{ij} or the energy absorbed.

A modification to the Monte Carlo method is called 'The Exodus Method' has been suggested by Emery and Carson (1968). This modification reduces computational time and improves accuracy. It is not dependent on the random number generator and may be applied to any problem which admits nodal network. This modification is the limiting case of the improvement first proposed by Klahr (1960). In this limiting method, the Exodus method, a large number of bundles (usually million) is dispatched simultaneously in directions controlled by the probabilities of going from one node to its neighbors. As these bundles arrive at the new nodal points, they are continually moved according to the probabilities until a set number have reached the boundaries (say 99.99 percent). According to the authors in this procedure, the Monte Carlo method smoothly approaches Exodus method. The use of the Exodus method in a computer program is slightly more difficult since two maps of nodal points are required - one just prior to the movement of the bundles and another after the movement has taken place. However, this complexity is more than compensated by the reduction in computational time and the accuracy. The nodal network representation of the physical systems sets the probabilities P_i a priori. Rectangular and triangular elements are acceptable. Even the transient problem can be solved by the Exodus method.

Modest (1978) suggests number of time saver techniques to speed up the Monte Carlo procedure. In problems where the spectral and directional dependences of the emissivity are separable, one random number can represent different wave lengths. Two more random numbers will establish direction of emission which is same for all temperatures. Further simplification is possible if the surfaces are purely specular reflectors which exhibit direction of reflection independent of wave length. Since the incoming solar energy exhibit such a specular characteristics in the narrow wave length band it can be considered in this manner. The computational time can be saved if the overall enclosure can be broken up into small numbers of basic surfaces dictated by the geometry and each surface can be further broken up into smaller isothermal subsurfaces. If these surfaces are parts of plane or convex surfaces, the leaving bundle will not make direct hit on the same surface. The bundle that is directed towards outer space through the sprawling openings including that towards the Sun and the Earth will never return. All these situations should be exploited since the trends of the results are known apriori and the information can be easily assessed. Probability theory can also be used to define the minimum number of bundles that should be considered consistent with the accuracy.

Accuracy and Computational Time:

Evaluation of view factor as depicted in Equation 2 and 3 by numerical methods involve summation instead of integration. In order to approach exact value it is necessary to subdivide the basic areas under considerations into smaller elements such that dA/r^2 is kept as small as possible. This approach is satisfactory only at the expense of increased computational time. When the two areas share a common boundary it is difficult to assure small value of dA/r^2 for the area elements in its vicinity. Hence, the results of numerical methods will be inaccurate unless special care is taken to subdivide the area elements in this zone in order to assure the same overall accuracy. The added complexity and additional computations will increase the time of execution. These radiation view factors are converted to radiative conductors in energy exchange calculations. It is possible that the two adjoining surfaces may have similar temperatures or the radiant heat flux exchanged by them be small. In such instances, the accuracy in the computation of view factors will hardly affect the end result. If the user has apriori knowledge of these facts it can be used advantageously. However, if the view factors from the basic surfaces to the space are computed by subtracting the sum of all the other view factors from unity, the user is left with no choice but to improve the accuracies in the computation of view factors to a considerable degree at the expense of increased time of execution. It is only appropriate to consider possible alternate methods of computing the view factors from the bodies to the sprawling space directly, instead of running the risk of increasing computational time in order to approach exact value which is at best asymptotically reached.

Consider a value of the view factor between two surfaces of 0.005. This value of view factor is for a rectangle 0.1 by 0.16 units seen from a point located one unit from one of its corners, the viewing planes being parallel to and seen by each other. This value of view factor is also obtained by a rectangle 0.1 by 0.66 units seen from the same point located one unit from one of its corner, but in this case, the viewing planes being perpendicular to and seen by each other. These examples serve to illustrate that the elemental areas in the numerical calculations must be much smaller in order to assure the indicated accuracy of 0.005 in the overall computational scheme.

Feingold (1966), considered the closed form solution of two rectangles having common edge first treated by Hamilton and Morgan (1952). He points out that in order to assure the accuracy of the results of the view factor equation to eight (8) digits the individual terms of this equation need to be evaluated to sixteen (16) digits. This situation is classical when the numbers of the same order are being subtracted. The discrepancy in the computed values by the original authors were discovered by using reciprocity relationships resulting in the need to generate higher level of accurate results. Even in the present case, similar higher level of accuracy need to be assured in order to evaluate the view factor from the body to the space by using all other component view factors. This illustration points out that for complex surfaces where such closed form solutions are unavailable and double area integrals are replaced by double summation even greater concern should be exercised. Again, Feingold considers the evaluation of the view factor of the regular hexagonal faces of a honeycomb structure by using the view factor values of the six adjoining faces of the enclosure with respect to the face. Recognizing, $F_{FF} = 1 - 6 F_{FS}$, an error of 0.0002 in evaluating view factor F_{SF} for a side/height ratio of 0.1 and using the reciprocity theorem as well as the suggested equation resulted in 57 percent error in F_{FF} , a value that can be directly calculated. Here was a case of Lambertian surface with closed form solution (extension of Hamilton and Morgan's solution) which resulted in enormous error. In complex geometries with directional and spectral variation of properties, it is tempting to blame the built in accumulated computational errors on the existence of non-Lambertian surface instead of having the luxury of evaluating the configuration view factors rather accurately and use them in energy calculations. These examples highlight the problems involved in working with geometrics having common edge and situations where dA/r^2 have not been kept below a certain low value when using double summation method. Even with the provision of idealized Lambertian surfaces for exposed orbiting equipment, the predicted results for the temperature variations can be erroneous since the energy loss to space may have been misrepresented.

It has been pointed out that the evaluation of view factor by contour integration instead of double area integration saves two line integration resulting in considerable simplicity. For the case of diffusively gray surfaces of complex geometries these line integrals can be represented by summation. Emery, Mortazavi and Kippenhan (1981), considered two rectangles of length = height $L = H$ having common edge and placed at right angles. The spacings S/L between the two rectangles of 0.0 (common edge) and 0.1 have been considered. Their results showing the percentage error generated by the numerical solutions using the above two methods when compared to the exact solutions (available for this problem) have been reproduced here as Table 1. Numerical method for the contour integration is very accurate. The double area integral solution obtained by double summation method is highly inaccurate. The reason for this error is again the proximity problem with dA/r^2 being too large for the elements close to the common edge.

Table 1. Percentage Error in the Numerical Calculation of the View Factor between two Surfaces of Equal Breadth (L=H)

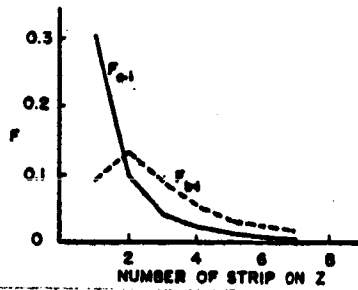
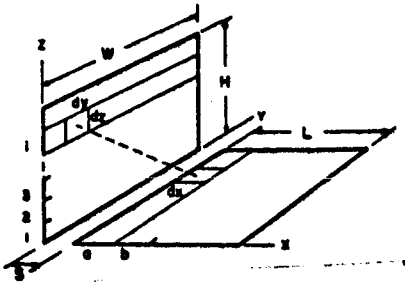

View factors between surfaces at right angles to each other and separated by the distance S.

Error based on exact solution to this problem $dA = dx.dz$ or $dy.dz$

Infinite Strip		Contour Integration Finite Area	Double Area Integral			
d/L	S=0.0%	S=0.0	S=0.0	S=0.1 L	S=0.0	S=0.1 L
1.0	0.2%	<u>3.7</u>	20.7	21.5	59.1	57.6
0.5	0.	0.8	12.9	11.2	32.0	24.1
0.3		0.4	9.1	6.6	21.8	12.1
0.2		0.1	5.7	2.8	13.2	4.9
0.1		0.	2.9	0.7	6.7	1.2
			1.5	0.2	<u>3.4</u>	0.3

$d = dx=dy=dz$ for the Double Area Integration
edge segment length for the Contour Integration

S = Separation distance along the x coordinate

S = 0.0, common edge problem

For example, using the numerical method for contour integration and treating the finite rectangles having common edge as single strips, the error when compared to exact solution is 3.7 percent. Contrary to this result, in the case of numerical summation for double integration using 400 elements per rectangle, the error is still 3.4 percent. It is amazing! Needless to state that the ratio of the computational time will be enormous! In the case of double summation method, for the same case with a spacing equal to 10 percent of the sides, the error has dropped to 0.3 percent. This differential from 3.4 percent is entirely due to proximity of the area at the common edge.

This above example illustrates convincingly that even for Lambertian surfaces having common edge or proximity to each other, it is necessary to further subdivide the area in its vicinity reducing the value of dA/r^2 to a small value consistent with overall accuracy. This comparison also suggests that in order to compute view factors between surfaces the subdivision of areas be done so as to preserve same value of dA/r^2 , thus assuring local accuracy of $F_{dA_i-dA_j}$ is about the same order of the required global accuracy F_{ij} between areas A_i and A_j as defined in Equation 1 and 3. It is this type of sensible use of computer codes which will cut down computational time while preserving both local and global accuracies as required by the user in the prediction of the true temperature excursions, even with the assumption of diffusively gray surfaces.

It has been pointed out that contour integration cannot be used for non-Lambertian surfaces and it takes considerable longer time when double summation is considered since it becomes necessary to consider the differential energy exchanges. This thought suggest the possibility of using Monte Carlo method.

Improvements in the accuracy of the basic view factor calculations can be achieved by specifying a small value, C , for the differential view factor $F_{dA_i-dA_j}$ as stated in Equation 1. In using numerical method, it is indeed $F_{\Delta A_i-\Delta A_j}$. If this calculated value is much smaller than the specified value (say 0.001 it points out that the initial subdivision of areas for double summation method (as used in TRASYS) is too small. On the otherhand, whenever the above differential view factor is above the specified value C that particular element need to be subdivided till the local differential value falls below the specified limit. Such a "do - loop" is standard in all computer programs. It should be noted that in the evaluation F_{ij} between surfaces A_i and A_j , the initial subdivision of areas may be such that the range of differential view factors contributing to F_{ij} may lie on either side of C , the specified limit. They indicate that the value dA/r^2 is either too small or too large. In order to add intelligence to the existing programs it is suggested that the initial subdivision of areas A_i and A_j be coarse and let the program do - loop containing the specified limit C divide them into sub areas so as to generate the same order of values for the differential view factors. This procedure will not only increase the global accuracies of individual view factor between two finite surfaces, but also saves considerable time. In adopting such a procedure care should be taken in situations where two surfaces sharing common boundary or near proximity to each other, since the value of dA/r^2 has been used as a guide to subdivide the areas. It may indeed cause unnecessary expenditure of computational time to assure accuracy which may be inconsequential in energy analysis. The test cases for such improvisations should indeed be the known problems having common edge for which the closed form analytical solutions do exist. As stated earlier, if the mutual surfaces have similar temperatures resulting in minimum exchange of heat the guideline for C , the specified limit can be relaxed.

The geometric view factors between two surfaces always satisfies the basic reciprocity relationships, i.e., $A_i F_{ij} = A_j F_{ji}$. The program should be instructed to evaluate the larger of the two values F_{ij} or F_{ji} which can easily be recognized since the information about A_i and A_j is available in the computer. Such an instruction will also aid in improving the accuracy and reducing the time. It is recognized that A_i and A_j are that portions of surfaces seen by each other, although each of ΔA_i need not see all of ΔA_j . The literature on radiative heat transfer mentions modified reciprocity theorems. The complexities of the surface arrangements in exposed orbiting equipment may not lend itself to take advantage of these theorems.

The evaluation of view factor from the surface A_i to space S can be calculated directly. However, some programs do evaluate this value by subtracting sum of all the other view factors by unity and listing only the positive values. The possibilities of negative results have been used to check the calculations that led to impossible results provided they are beyond the expected overall accuracy. This procedure does not exclude the error involved in computing this important view factor to the space even when positive values are indicated. If the indirect method to evaluate the geometric view factor to the space is the only method, instead of using

$$F_{i-S} = 1 - \sum_{j=1}^N F_{ij} \quad (34)$$

where the total enclosure contain outer space and N surfaces, it is suggested to use

$$F_{\Delta A_i - S} = 1 - \sum_{j=1}^N F_{\Delta A_i - A_j} \quad (35)$$

and

$$F_{A_i - S} = \frac{1}{M} \sum_{i=1}^M F_{\Delta A_i - S} \quad (36)$$

where M is the number of equal area elements the surface A_i is divided in the evaluation of Equation 35. If the surface A_i is divided into unequal areas it is possible to modify Equation 36 to reflect weighted area in the evaluation $F_{A_i - S}$ the important view factor to the space. Such a modification may be viewed as semi-indirect method of evaluation of the view factor to the space. The work of Sawyer (1978) considers view factors between enclosing surfaces in the presence of occluded cylinders (surfaces). The basic concepts of this study can be extended to the current problem of exposed orbiting equipment in space. The work of Sawyer is a part of VIEWFAC program which also contains formula for octal memory required in the computer for typical problems.

The accuracy of view factor as determined by finite element method is comparable to finite difference method, using double summation. Chung and Kim (1982) compares the results obtained by analytic solution with that of contour integration and finite element method. For the case of opposite faces of a cube, the finite element method require 3x3 elements to generate the view factor comparable to analytic solution and contour integration method. In order to obtain similar comparative results for adjacent faces it requires 40x40 elements. For the adjacent faces with angle less than 90° (say 60° and 30°) the values for 40x40 elements did not converge to the analytic values (2.73 and 10.9 percent error). The contour integration method provided the values for the view factors in close agreement with the analytic solution (0.36 and 0.9 percent error). The error indicated for the 40x40 mesh finite element method is unacceptable pointing again to the effect of dA/r^2 in the numerical evaluation. Wu, Ferguson and Altgilbers (1980) considered the application of finite element method to the interaction of conduction and radiation in an absorbing, scattering and emitting medium. They point out that for a 200-node problem it requires 40,000 (40K) words of storage to define the radiosity equation. The use of peripheral mass storage and "out of core" matrix inversion algorithms permit enlarging the number of nodal elements, limited only by the computer economics at the upper end.

Vogt (1981) in a paper on recent developments in Thermal Radiation Analysis System (TRASYS) recommends evaluation of view factor to space directly in order to improve the accuracy. The accuracy depends on the method employed but certainly avoids built in accumulated error when it is obtained by subtracting all the other view factors of the adjoining surfaces from unity. The new Form Factor Calculation (FFCAL) link, described by Vogt, automatically chooses between the double summation and the unit sphere methods in order to improve the accuracy of the nodes that are close to each other. The reduction in computational time with such a frequent switch over has been expected to be 40 percent. Another interesting paper in this area is by Farrell (1976) which discusses the determination of view factors of irregular shapes such as the sprawling space as seen by a point. It is based on the unit sphere concept introduced by Herman (1900). The paper describes the development of the scintiloscope which uses the perspective projection concept aptly describing the geometric view factor as stated by Equation 2, between a point to an object in space (here, sprawling space surrounded by the objects of exposed orbiting

equipment). The idea of Farrell can be computerized in order to evaluate all the required geometric view factors directly. The accuracy of these geometric view factors to important surfaces which exchanges significant energy can also be increased very much like subdividing the interval in numerical integration in order to increase the convergence.

The accuracy of view factors obtained by Monte Carlo method depends on the size of the bundles and randomness of the path selected. Early effort to use this procedure has been branded as one requiring large memory space and inefficient use of computer time. However, the concepts of the procedure is ideally suited to produce accurate results for real surfaces having directional and spectral property variations and integrated approach (for example, coupling of TRASYS and SINDA) is used in energy calculations. Modest and Poon (1977) comment about the accuracy and convergence of the Monte Carlo method when applied to the determination of the geometric view factor between square parallel plates separated by a distance equal to fourth of their sides. They point out that the sets of random number for the Monte Carlo procedure had to be generated on the computer using analytical schemes which can never be truly random. They can at best be called as "quasi-random" which depends on the initial starting value. They indicate that this starting value had considerable influence on the convergence of the view factor to the analytic value, suggesting optimization to select this starting value. For the illustration they considered with a starting value of "unity" even after 5000 bundles the convergence is poor. However, when optimized starting value of "12,345" is selected, initial convergence at 1000 bundles is indicated. They use random number generator contained in NASA - Houston software package for their UNIVAC 1110 in obtaining these values. For larger size bundles the result oscillated around expected value and damping indicated only after using 4000 bundles.

The work of Modest and Poon under NASA/JSC Grant No. NAS9-15109 was to determine the three dimensional radiative exchange factors for the Space Shuttle by using Monte Carlo method. In particular, their study has been directed to radiation exchange between the curved Shuttle door, and radiating panels forming cavity in the open configuration, both being exposed to solar radiation at various angles of incidences. The surfaces were specularly reflective and the problem was directed to predict rather accurately the energy concentration near the hinge between the door and the panel. For black surfaces the Monte Carlo procedure with the optimized starting value of 12,345 showed good convergence with expected values of view factors obtained by Hottel crossed-string method using only 1000 to 2000 bundles.

Modest and Poon (1977) have compared the results obtained by TRASYS and Monte Carlo with the experimental data obtained by Scheps and H. R. Howell (1976) of Vought Corporation under contract with NASA/JSC. The test facility simulated the cavity formed by the Shuttle door and radiator panel, with a baseline deployment angle between them being 38 degrees. In the simulator, Xenon lamps represented the beam radiation from the Sun. The panels were about 3x5 meters. The doors and panels had a coating of silver/teflon material. A white blanket made out of beta cloth bonded to thin aluminum sheet was used to cover the door and assess the effect of diffuse surface coating on the

net radiation trapped in the cavity. The back of the door contained 10 to 20 layers of aluminized mylar in order to minimize the heat leaks. For purposes of evaluating the local view factors to space using measured local heat fluxes, the door and the panel have been divided into strips and each strip into zones. The comparison of experimental results of Scheps and Howell with the Monte Carlo method on a zone-by-zone basis has been made by Modest and Poon. Except for the zones near the hinge (indicating the effect of proximity of two surfaces), the Monte Carlo method using the absorptivity of silver-teflon material (at room temperature) as 0.78 predicted about the same values of gray surface radiation view factors (B_{ij}) on a zone-by-zone basis. In this comparison, each strip has been divided into three zones. The end zone cavity view factor to space as predicted by Monte Carlo method is not symmetric (about one percent or less difference). This is due to inherent oscillation around the expected value associated with the statistical nature of the method itself, and use of limited bundles in increments of hundreds. It should be noted that the asymmetry is much larger with the experimental result (about 3 percent), which is to be expected. The results of view factors from the flat strips (three zones) of the cavity to space, obtained by TRASYS (1973) using diffusively gray emitting surfaces having absorptivity of 0.78, is consistently higher than the experimental values which agrees closely with Monte Carlo predictions. The paper of Modest and Poon contain more detailed comparison of view factors between strips and each strip to space as determined by experiments and Monte Carlo method. It also contains comparison of view factors between the front opening and the strips on the radiator panel facing the door due to solar irradiation. Here, the solar absorptivity of 0.06 for 46 degree angle opening gave a reasonable good agreement between the Monte Carlo method and the experiment. With increasing angle of opening the solar absorptivity had to be artificially increased in order to obtain better agreement between the two methods. It should be noted that at an opening of 77 degrees both the concave door and the back of the radiator panel are fully sunlit. The comparison is also made with TRASYS results using a diffuse solar absorptivity of 0.15. The agreement is inferior when compared to Monte Carlo method. The availability of more complete radiative properties of the surfaces will no doubt improve the comparison between the theory and the experiment.

Sowell and O'Brien (1972) describes F - matrix method in order to efficiently compute view factors within the enclosure. The method is based upon the fact that one view factor in each row of the F - matrix must be determined by conservation equation of that row, that is algebraic sum of the view factor be equal to unity. The reduction of the method to evaluate all the required view factors utilizes reciprocity relationships. They utilize CONFAC II program by Toups (1965) for basis view factors which forms the elements of F - matrix. A Fortran computer procedure is presented. Details of the procedure can be found in the Ph.D dissertation of Sowell (1972). A method to evaluate view factors between surfaces that are partially occluded by other surfaces has been presented by Wiebelt (1972). The computational time required for this program is about twice that of CONFAC II. However, this program uses coarser grid and the expected accuracy is within 2 percent when the occluding surface is close to the viewing plane.

Vogt (1981) points out that in the evaluation of view factors in a complex enclosure such as exposed orbiting equipment, 90 percent of CPU time in the TRASYS program is used up in shadow routines. A significant reduction in time can be achieved if the shadow tables for the specific attitude and orbital position are used. These tables need to be generated and stored prior to computations of view factors. The expected reduction in time is about 50 percent. The newly available FFCAL link for TRASYS II (1977) utilizes the unit sphere method and double summation method interchangeably in order to save computational time by about 40 percent. The FFCAL link utilizes the accuracy specified by the user and Equation 1 in determining the grid sizes. (See Appendix B, TRASYS II, 1977). This method will automatically subdivide the nodes in the region where the surfaces are close to each other. Number of other improvements, time saving steps as well as improved accuracy which are part of TRASYS II indicated by Vogt are; explicit form factor to space (GBCAL link), identical form factor request matrix, restart tape form factors update, trajectory tape input, extended orbit generator capabilities and possible shadower.

Emery, Mortazavi and Kippenhan (1981) point out that the key to reducing computation time is the early detection of obstructions between the elements ΔA_i and ΔA_j . They have not found effective method for such an early detection. They recommend fixed pattern of checking and repeating the same at every location of ΔA_i . The thought expressed by them suggest development of shadow pattern on the surface A_j as viewed from A_i in the presence of occluded surfaces. They emphasize that double area integration for surfaces having common edge leads to inaccurate results, but it is the only method to establish the obstructed view. Hence, such situations should be avoided by properly defining the surfaces. They point to the development of hardware having the capability of generating perspective view with hidden portion of surfaces identified which is as yet unavailable. Utilizing the fixed pattern of checking for obstructions they have shown that the reduction in computational time of 50 to 75 percent in the two isolated examples they considered.

Vogt (1981) emphasizes that the evaluation of geometric view factors of complex structures can be achieved at a greater speed if a fast interactive program with good graphic capability can be developed. For the present, a combination of contour integration and double summation in concert with ray intersection calculations provides the fastest method of calculations. The use of rays may be regarded as highly adaptive Monte Carlo method.

Monte Carlo methods for radiative heat exchange calculations are considered extremely slow and the accuracies are subjected to the choices of random number generators and sizes of bundles used. They require fast computers with large memory space in order to converge on required answers at reasonable values of CPU time. Emery and Carson (1968) compares the computation times of the Exodus method with Monte Carlo and finite difference methods. In the examples considered by them the Exodus method with million bundles took about 10 percent of time taken by Monte Carlo with about 2000 bundles. The computational time for finite difference method is comparable to Exodus method. While the Monte Carlo method shows oscillatory characteristics in converging to final value, the Exodus method exhibits steady convergence to final value. In passing, it may be noted that the application of Exodus method to matrix inversion is much more efficient than Monte Carlo and it is comparable to algorithms for exact method. Modest (1978) has proposed a number of time saver schemes for Monte Carlo method.

In the future, it should be of interest to apply the improvised porcedures to the problems of current interest and compare the same with Exodus method. Modest in applying the Monte Carlo method with time saver schemes to the problem of cavity formed between Space Shuttle payload bay door and radiative heat rejector panel, has shown the superiority of this method over TRASYS for accuracy since it considers specular properties. The execution time on the UNIVAC 1110 using 10,000 - 20,000 energy bundles to assure an accuracy of ± 0.005 was about 60 sec for each incidence angle of the sun shining into the cavity.

Computer Programs:

There are a number of general purpose heat transfer analysis programs that are available largely due to significant advances made in numerical discretization techniques and the rapid developments achieved in computer hardware and software packages. Noor (1981) claims that there are anywhere up to seventy such programs many of which are being used by government and industries to develop analyses for practical problems. He presents a comprehensive review of 38 such programs by categorizing their features under various classifications of heat transfer problems itself, methods available, computer facilities that can be used and the methods of representation of the solutions. Here sixteen of these programs⁸ have been selected which have capabilities for radiation, convection and internal conduction required for solving problems of exposed orbiting space equipment with its convective loops to hold the temperatures of the individual units at the required temperature. Table 2 gives the list of the programs selected, the addresses of program developers, the computer language used and the contact person, where available, for further information. The programs ASAS HEAT, BERSAFE (FLHE) and TAU are from England and SAMCEF (THERNL) is from Belgium. The remaining twelve programs are from the United States out of which six of them coming from California based agencies.

Here, in this laboratory, SINDA (Systems Improved Differencing Analyzer) program (1971) is utilized. It employs finite difference scheme with lumped parameter representation of physical problems governed by diffusion mode. It features resistor capacitor (R-C) network representation. It is backed up by TRASYS (Thermal Radiation Analysis System), a digital computer software, having capability to solve radiation related aspects of thermal analysis problems such as view factors. In combination with SINDA the heat transfer mechanism in space is represented as radiation conductor, suitable for thermal network analysis. TRASYS utilizes view (form) factor accuracy (FFACC) specified by the user in conjunction with Equation 1 representing differential view factor between surfaces ΔA_i and ΔA_j . Having specified FFACC, the smallest ΔA_i is given by

$$\Delta A_i = \frac{FFACC (\gamma_{ij})^2}{\cos \beta_i \cos \beta_j}$$

When the two surfaces A_i and A_j are close to each other the average distance \bar{r} or \bar{r}_{ij} is smaller and Equation 37 suggests consideration of smaller area elements for the evaluation of view factor F_{ij} needed for radiation heat transfer analysis. It should be noted that even with the use of Equation 37 to define minimum size of ΔA_i , the regions of A_i and A_j where the local values of r is smaller than the average value of \bar{r} , the errors in view factor calculations should be expected. The seriousness of this problem is aggravated when areas having common boundary is encountered. The consequences have been discussed in the previous section titled, "Accuracy and Computational Time."

Letters of communication to our William C. Patterson by Mr. J. D. Gaski suggest that Mr. Gaski is the originator of SINDA (1971), his contributions being detailed discussions of the thermal network error correction package and the sensitivity temperature error program. Mr. Gaski is in the process of completing

⁸

At the time of writing this report a separate effort of the author to secure technical backgrounds (theoretical manuals) of these programs in order to independently evaluate the potentials was unsuccessful. The time limitation of the Fellowship program itself was also a factor.

TABLE 2: Computer programs having Heat Transfer Analysis capabilities selected for survey (taken from Ahmed K. Noor, NASA/CP 2216 (1981).

1. AGTAP

Advanced General Thermal Analyzer Program. Grumman Aerospace Corporation, Bethpage, New York, 11714. FORTRAN IV.1000 thermal nodes with 2000 each conductive and radiation connectivities. Contact: Dr. John G. Roukis, mail stop B22/35.

2. ANSYS

Swanson Analysis Systems Inc., P. O. Box 65, Johnson Road, Houston, PA 15342
ANSI FORTRAN.

3. ASASHEAT

Linear/Nonlinear Thermal Analyzer of the ASAS Range of Finite Elem.Program. Atkins Research and Development, Parkside House, Woodcote Grove, Ashley Road, Ebsom, Surrey, England. Portable ANSI FORTRAN 66.

4. BERSAFE (FLHE)

Flow of Heat by Finite Elements. Central Electricity Generating Board, Berkeley Nuclear Laboratories, Berkeley, Gloucestershire, GL13 9PB, England. FORTRAN IV developed by Dr. T. K. Hellen and colleagues. Contact: Mr. G. Marshall.

5. MARC

MARC Analysis Research Corporation, 260 Sheridan Avenue. Suite 200, Palo Alto, CA 94306. FORTRAN IV.

6. MITAS II

Martin Marietta Interactive Thermal Analysis System, Version 2.0. Martin Marietta Corporation P. O. Box 179, Denver, Colorado, 80201. CDC FORTRAN 2.4. Developed by R. E. Kannady, Jr. R. J. Connor and C. E. Shirley. Contact: Roy E. Kannady, Jr., (303) 977-3075 .

7. MSC/NASTRAN

The MacNeal - Schwendler Corporation - NASA Structural Analysis. The MacNeal - Schwendler Corporation, 7442 North Figueroa Street, Los Angeles, CA 90041. FORTRAN IV, contact: MSC Regional Office at Los Angeles (213) 254-3456.

8. NNTB

Nodal Network Thermal Balance Program. NASA-Goddard Space Flight Center, Code 732, Betsville, Maryland, 20771. 300 Nodes Capability. FORTRAN IV. Contact: COSMIC, Suite 112, Barrow Hall, The University of Georgia, Athens, GA 30602.

TABLE 2: (Continued)

9. SAHARA

Sandia National Laboratories, Livermore, CA 94550. CRAY-CFT and CDC-FTN FORTRAN. Developed by V. K. Gabrielson, Organization 8331. Contact: V. K. Gabrielson.

10. SAMCEF(THERNL)

Systeme d'Analyse des Mileax Continus Par Elemets Finis (Thermique Non Lineaire). L.T.A.S., Aerospace Laboratory, University of Liege, Rue Ernest Solvay 21, B-400 Liege, Belgium, FORTRAN IV. Contact: L.T.A.S., Aerospace Laboratory.

11. SINDA

Systems Improved Numerical Differencing Analyzer. Program Developers: Chrysler Corporation, Space Division, New Orleans, LA; TRW Systems, Redondo Beach, CA ; TRW Systems, Houston, TX; LTV Aerospace Corporation, Dallas, TX; Lockheed, Houston TX. FORTRAN>Contact: COSMIC, Suite 112, Barrow Hall, University of Georgia, Athens, GA 30602.

12. SPAR

Engineering Information Systems, Inc. 5120 West Cambell Avenue, Suite 240, San Jose, CA 95130. FORTRAN V Contact: James C. Robinson, Loads and Aeroelasticity Division, Mail Stop 243, NASA Langley Research Center, Hampton, VA 23665.

13. TACO

Sandia National Laboratories, Livermore, CA., 94550. ANSI FORTRAN Contact: W. E . Mason, Applied Mechanics Department.

14. TAC3D

Thermal Analysis Code - Three Dimensional. General Atomic Company, P. O. Box 81608, San Diego, CA 92138. FORTRAN V.

15. TAU

Thermal Analysis of Uncle. U. K. Atomic Energy Authority (UKAEA), Risley Nuclear Power Development Establishment, Warrington, Cheshire WA3 6AT, England. FORTRAN IV.Developed by J. A. Enderby.

16. TEMP (NTEMP)

Temperature Analyzer (New Temperature Analyzer). Dr. A.F. Emery, Dept. of Mechanical Engineering, University of Washington, Seattle, Washington 98195. FORTRAN Extended, Cost \$250.00.

"New SINDA" program. He claims that the existing versions of the SINDA program and their many modifications created by various users have deficiencies, inaccuracies, incompleteness, errors and insufficient global documentations. According to Mr. Gaski the new SINDA will have the following features:

- Substantially reduced core size requirements as well as reduced computational time for processing and solution phases.
- Increased problem size capability with several mnemonic data options.
- Operational on CDC and UNIVAC computers with possibility of CRAY and IBM computers.
- Use of CAD color graphics packages such as PATRAN coupled with translators or emulators which allow the user to automate the input to large analysis code such as new SINDA, NASTRAN (NASA Structural Analysis), NEVADA (Net Energy Verification and Determination Analyzer) etc., which offer order of magnitude reductions in overall problem execution times.
- Improvement in Interanalysis Communication and Coupling.
- Estimated 90 percent reduction in preprocessor time and close to a 50 percent reduction in execution time.
- Total rewrite of preprocessor with an entirely different structural base and internal operation instead of patch up jobs that have occurred in 10 years.
- Anticipated submodel definition which will allow several models to serve as input with overlapping number systems. This feature will slow down the overall preprocessor speed, but should not effect execution timing.

Current status of New SINDA, according to the telephone conversation on August 5, 1982 with Mr. J. D. Gaski, (SINDA Industries Inc., P. O. Box 8007 Fountain Valley, CA 92708, Telephone (714) 557-2080). The New SINDA is 80 percent coded and 50 to 60 percent has been checked out. Old SINDA (Revised 82) is available at Aerospace Corporation. The 83 version of Old SINDA with pressure node is in the making for them. The NOPACK version that is available utilizes larger core space, but it runs faster. In SINDA (1971), source data block had lots of errors which have been removed. New SINDA will have Monte Carlo version which directly calculates the gray surface radiation view factor B_{ij} in a single pass instead of TRASYS II which does the same in two passes, first, computing the geometric view factor F_{ij} and then B_{ij} . New SINDA will accept both TRASYS II and NEVADA (Monte Carlo). It is expected that for 1000 nodes or larger NEVADA Monte Carlo method is faster which agrees with other independent claims. moreover, the Monte Carlo method is more versatile. At present, Mr. Gaski is working with Aerospace Corporation on Space Shuttle thermal models for the U. S. Force. NASA, Houston is expected to review these results and based on the satisfactory outcome of comparisons between the two SINDA programs they will authorize the use of New SINDA at the various NASA centers.

Table 3 presents a detailed summary of the capabilities of the sixteen programs depicted in Table 2 for comparison. The information for this table is entirely due to Noor (1981). The tabular survey will be useful in the initial selection of a program or two for heat transfer analysis. The final selection of the suitable program has to be based on a detailed examination of the documentation as outlined in theoretical, programmer's and user's manuals. Since the computer softwares continuously change, often at a rapid rate, most up-to-date information should be sought in order to make final selection. Noor, in a panel discussion with Mr. Sidney Dixon (1981) as moderator, points out that many of the recent advances in computational structural and fluid mechanics have not been used in heat transfer analysis. Such an integration is essential and should be forthcoming. At present finite element methods are lagging behind finite difference method for heat transfer analysis, but their superior advantages in terms of mesh design, formulative aspects coupled with integrated design features and capabilities for transient analysis will be the tool of the future. The availability of a number of large general purpose software, the ushering in of super computers, array processors and microprocessors will also play important role in advancing computational methods including heat transfer models.

Some general comments about Table 3 are as follows:

- All of the programs except four have been updated during 1981. One of these programs is SINDA (1975) which is being updated and it is being reviewed at NASA/JSC for future use at all NASA centers.
- Ten out of sixteen programs utilizes finite element method of analysis. SINDA uses finite difference method. If the anticipated revision (NEW SINDA) utilizes current state of the art of finite difference methods such as curvilinear grids and higher order finite difference techniques, it should be comparable to finite element methods.
- All the programs have temperature as fundamental unknown. Four of these programs considers heat flux as also fundamental unknown. SINDA is not one of them.
- All the programs considers temperature dependent thermo-physical properties.
- All the programs except two considers interelement convection and radiation.
- Only MSC/NASTRAN and TACO have enclosure radiation with view factor calculations internal to the program. Others require supporting programs.
- All of the programs have restart capabilities.

Based on detailed review of the theoretical manuals of these programs, it should be possible to select two or three programs for further scrutiny. Here it is recognized that standard problems which exploits capabilities of these final selection of programs should be used to compare the accuracy, the consistency and the efficiency of computations.

TABLE 3. SURVEY OF COMPUTER PROGRAMS CAPABILITIES USED IN HEAT TRANSFER ANALYSIS

SCOPE AND CAPABILITIES OF THE PROGRAMS	AGAP	ANSYS	ASAS HEAT	QERSAFE (FLHE)	MARC	MITAS II	MSC/NASTRAN	NNTB	SAHARA	SAMCEF (THERNL)	SINDA	S2AR	TACO	TAC3D	TAU	TEMP (NTEMP)	
	80 81 81 81 81 81 81 81 81 81 81 81 81 81 81 81 81	80 81 81 81 81 81 81 81 81 81 81 81 81 81 81 81 81	80 81 81 81 81 81 81 81 81 81 81 81 81 81 81 81 81	80 81 81 81 81 81 81 81 81 81 81 81 81 81 81 81 81	80 81 81 81 81 81 81 81 81 81 81 81 81 81 81 81 81	80 81 81 81 81 81 81 81 81 81 81 81 81 81 81 81 81	80 81 81 81 81 81 81 81 81 81 81 81 81 81 81 81 81	80 81 81 81 81 81 81 81 81 81 81 81 81 81 81 81 81	80 81 81 81 81 81 81 81 81 81 81 81 81 81 81 81 81	80 81 81 81 81 81 81 81 81 81 81 81 81 81 81 81 81	80 81 81 81 81 81 81 81 81 81 81 81 81 81 81 81 81	80 81 81 81 81 81 81 81 81 81 81 81 81 81 81 81 81	80 81 81 81 81 81 81 81 81 81 81 81 81 81 81 81 81	80 81 81 81 81 81 81 81 81 81 81 81 81 81 81 81 81	80 81 81 81 81 81 81 81 81 81 81 81 81 81 81 81 81	80 81 81 81 81 81 81 81 81 81 81 81 81 81 81 81 81	
MOST RECENT UPDATE/FIRST RELEASE	G	G	G	B	B	B	B	G	G	B	B	G	G	B	B	B	G
GOAL OF PROGRAM SYSTEM: B - GENERAL PURPOSE B - ALSO RESEARCH CAPABILITIES	G	G	B	B	B	B	B	G	G	B	B	G	G	B	B	B	G
METHOD OF ANALYSIS: E - FINITE ELEMENT D - FINITE DIFFERENCE	D	E	E	E	E	D	E	D	D	E	D	E	E	D	E	E	E
FORMULATION - FUNDAMENTAL UNKNOWN: T - TEMPERATURE, B - ALSO HEAT FLUX - CAPACITANCE REPRESENTATION: C - CONSISTENT, L - LUMPED, B - BOTH - CONVECTION REPRESENTATION: N - NATURAL (FREE), F - FORCED, B - BOTH - INTERELEMENT CONVECTION AND RADIATION: Y - YES, N - NO	T	T	T	T	T	B	T	B	T	B	T	B	T	B	T	T	T
	L	B	C	C	B	L	B	L	L	B	L	B	B	L	C	B	B
	F	B	N	B	B	B	B	-	B	F	B	B	B	-	B	B	B
	N	Y	Y	Y	N	Y	Y	Y	Y	Y	Y	Y	Y	N	Y	Y	Y
TEMPERATURE DEPENDENT PROPERTIES: CONDUCTIVITY SPECIFIC HEAT DENSITY ABSORPTIVITY/EMISSIVITY CONVECTION COEFFICIENTS	Y	Y	Y	Y	Y	Y	Y	N	Y	Y	Y	Y	Y	Y	Y	Y	Y
	Y	Y	Y	Y	N	N	N	N	N	N	N	N	N	N	N	N	N
	Y	Y	Y	Y	N	N	N	N	N	N	N	N	N	N	N	N	N
	N	Y	Y	Y	Y	Y	Y	N	Y	Y	Y	Y	Y	Y	Y	Y	Y
INITIAL CONDITIONS N - HOMOGENEOUS, U - USER SUPPLIED V - VARYING THROUGHOUT THE REGION A - ALL THREE ENTRIES	U	H	A	A	A	U	A	H	H	A	A	A	H	U	A	H	V
								V	V	V	V	V	V	V	V	V	V

* REVIEW THE NUMBER OF FOOTNOTES DESCRIBING CHARACTERISTICS GENERALLY COMMON TO ALL SIXTEEN PROGRAMS WHICH ENABLED TO CAST THIS TABLE INTO MORE COMPACT FORM. INFORMATION TAKEN FROM AHMED K. NOOR, NASA/CP2216 (1981)

CONTINUED

SCOPE AND CAPABILITIES OF THE PROGRAMS	AG TAP	ANSYS	AS AS HEAT	BERSAFE (FLHE)	MARC	MITAS II	MSC/NASTRAN	NNTB	SAHARA	SAMCEF (THERNL)	SINDA	SPAR	TACO	TAC3D	TAU	TEMP (NTEMP)	
BOUNDARY CONDITIONS AND THERMAL LOADS: -- RADIATION AND CONVECTION FROM SURROUNDINGS TO SURFACE AND VICEVERSA S -- STEADY STATE, T -- TIME DEPENDENT, B -- BOTH -- RADIATION BETWEEN NARROW GAPS Y -- YES, N -- NO -- RADIATION BETWEEN 'n' SURFACES WITH U -- USER SUPPLIED VIEW FACTORS, I -- INTERNALLY CALCULATED VIEW FACTORS, B -- BOTH SEE ALSO FOOTNOTES, 'BOUNDARY CONDITIONS'	T	B	B	B	B	B	B	S	B	B	B	B	B	T	B	B	
	N	Y	Y	Y	Y	Y	Y	N	N	Y	Y	M	Y	Y	Y	N	
	U	U	-	U	-	U	B	U	U	U	U	U	B	I	I	U	
SOLUTION TECHNIQUES AND OTHER CAPABILITIES: -- LINEAR STEADY STATE: D -- DIRECT, I -- ITERATIVE, O -- OTHERS -- NONLINEAR STEADY STATE: I -- ITERATIVE, N -- INCREMENTAL, O -- OTHERS -- TRANSIENT DIRECT INTEGRATION: E -- EXPLICIT, U -- IMPLICIT WITH USER SPECIFIED STEP, A -- IMPLICIT WITH AUTOMATIC TIME STEP SELECTION, C -- COMBINED EXPLICIT/IMPLICIT -- THERMAL STRESS ANALYSIS WITH FINITE ELEMENT METHOD: C -- COUPLED U -- UNCOUPLED -- ENCLOSURE RADIATION WITH VIEW FACTOR CALCULATION Y -- YES, N -- NO -- HEAT INPUT/OUTPUT AT CONSTRAINED BOUNDARIES: Y -- YES, N -- NO -- RESTART CAPABILITY: Y -- YES N -- NO	-	D	D	D	D	I	D	D	I	D	I	D	I	D	I	D	
	-	I	I	I	I	I	I	O	I	I	I	I	I	I	I	I	
	E	U	U	U	U	E	U	A	U	E	E	E	U	U	U	U	
	-	C	U	U	U	-	C	-	-	U	-	U	-	-	U	-	
	N	N	N	N	N	M	Y	N	N	N	N	N	M	Y	N	Y	N
	N	Y	Y	Y	Y	Y	Y	Y	Y	N	Y	N	Y	N	N	Y	Y

CONTINUED

SCOPE AND CAPABILITIES OF THE PROGRAMS	AG TAP	ANSYS	ASAS HEAT	BERSAFE (FLHE)	MARC	MITAS II	MSC/NASTRAN	NMTB	SAHARA	SAMCEF(THERNL)	SINDA	SPAR	TACO	TAC 3D	TAU	TEMP (NTEMP)
PROGRAM OPERATIONAL USING: - C - CDC, I - IBM, U - UNIVAC A - ALL THREE M - MIMICOMPUTERS, S - SUPER COMPUTERS, B - BOTH	I	A	I	I	A	C	A	I	C	A	A	C	C	U	I	C
DOCUMENTATION: P - PROGRAMERS MANUAL T - THEORETICAL MANUAL, U - USERS' MANUAL, A - ALL THREE E - EXAMPLE PROBLEM MANUAL, V - VERIFICATION/VALIDATION MANUAL, P - PRE- AND POST-PROCESSORS' MANUAL A - ALL THREE, N - NONE	A	T	A	A	A	U	A	T	U	T	P	T	T	P	U	P
INPUT FORM: F - FIXED FORMAT, L - LIST DIRECTED (FREE) FORMAT P - PROBLEM ORIENTED LANGUAGE, A - ALL THREE	F	L	L	A	F	L	A	F	F	F	P	L	F	F	L	L
INPUT SEQUENCE: U - USER DIRECTED, S - SYSTEM DIRECTED P - PART OF USER SUPPLIED SUBROUTINE, A - ALL THREE	U	U	S	S	U	S	S	S	U	U	S	A	U	S	U	S
MODEL GENERATION AND CHECKING: AUTOMATIC OR SEMI-AUTOMATIC GENERATOR FOR: N - NODAL POINT COORDINATES, E - ELEMENT CONNECTIVITIES, C - SYMMETRY AND BOUNDARY CONDITIONS CONSTRAINTS, A - ALL THREE S - SUBSTRUCTURE CONNECTIVITY, R - REPETITION OF IDENTICAL SEGMENT, O - OTHERS ELEMENTS: - O - ONE DIMENSIONAL T - TRIANGULAR, Q - QUADRILATERAL, A - ALL THREE ELEMENTS: - B - BODY OR SHELL OF REVOLUTION, 3 - THREE DIMENSIONAL SOLID, 2 - TWO DIMENSIONAL SHELL, A - ALL THREE	C	A	A	A	A	A	A	A	N	A	A	N	A	N	A	N
	R	R	S	R	R	S	R	R	-	R	-	O	-	-	R	R
	-	A	A	A	A	A	A	A	Q	A	A	A	Q	-	T	A
	-	A	A	A	B	3	2	3	B	A	3	B	3	B	B	B

FOOTNOTES TO TABLE 3 DEPICTING GENERALLY COMMON CHARACTERISTICS
APPLICABLE TO SIXTEEN PROGRAMS OF THIS SURVEY

- All have three dimensional space capabilities except TACO.
- All have linear/nonlinear steady-state and transient response capabilities except AGTAP which has only nonlinear capability and TAC3D which has only linear capability.
- All have models for internal conduction represented by elemental matrices.
- All have models for radiation except AGTAP and TAC3D.
- Multilayered capabilities only for MITAS II, TAU, and TEMP.
- All accommodate time dependent thermal properties except ANSYS, MSC/NSTRAN, and NNTB.

Boundary Conditions

- All accommodate steady-state prescribed temperatures and steady-state thermal flux input except AGTAP and TAC3D.
- All accommodate time dependent prescribed temperatures.
- All accommodate temperature dependent thermal flux input except AGTAP, ANSYS, NNTB, SAHARA, and TAC3D.
- All accommodate time varying thermal flux input except AGTAP and TAC3D.
- All accommodate forced convection except ASAS HEAT, NNTB, SAHARA, and TEMP.
- All accommodate prescribed fluid flow except ASAS HEAT, MARC, NNTB, and TACO.
- Those that accommodate boundary layer convection are; ASAS HEAT, MARC, MSC/NASTRAN, SAHARA, and SPAR.
- All accommodate gap thermal resistance except AGTAP, ASAS HEAT, NNTB, and TEMP.
- All accommodate boundary conditions/loads added or removed during analysis except NNTB and TACO.

Solution Techniques

- All programs using finite element methods of analyses have the feature to transmit temperature field data directly from heat transfer modules to thermal stress modules except TEMP.
- Cyclic symmetry capability is available only for MSC/NASTRAN and TAU.
- Repeated use of identical substructures capability is available only for ANSYS, MSC/NASTRAN, and SAMCEF (THERNL).
- Mixing linear and nonlinear substructures capability is available only for ASAS HEAT, MSC/NASTRAN, and SAMCEF (THERNL).
- All programs have suitable file output for user post-processing and plotting except NNTB, TAC3D, and TEMP.

Conclusions and Recommendations:

This report is based on the literature reviews related to the thermal radiation view factor as it applies to computations of temperature variations in the exposed orbiting equipment. The thermal balance of such an equipment depends on impinging solar radiation, the reflected energy from the earth, the energy lost to sprawling space, the mutual radiative heat transfer among the surfaces, the internal heat generation and the heat transfer from the convective loops. This report provides a broad brush approach discussing the various methods available for calculating thermal radiation view factors, the accuracy of procedures when computer-aided procedures are used and the computational time required to achieve satisfactory results.

The current procedure at the MSFC Laboratory requires two pass approaches, that is, calculation of radiation view factors (TRASYS) and convert them to space conductors (SINDA) in order to perform thermal balance. Besides discussing the basic concepts involved in determining the geometric view factor, in developing the radiation thermal resistance analogy and the assumption involved, this report contains interpretation of the basic methods available for radiation geometric view factor calculations such as Nusselt projection (Unit-Sphere) method, the ray tracing technique for the same, the double integration/summation method, the Hottel's stretch film (Crossed-String) method the contour integration method and the Monte Carlo method. The last method is suitable for directly calculating energy transfer between surfaces having known radiation properties (one pass approach) essentially for Lambertian gray surfaces. This report also contains discussion and status of the available numerical procedures such as iterative procedure, finite difference and finite element procedures and Monte Carlo procedure. More efficient ways available in the literature that are applicable for these basic procedures are also discussed.

In order to aid in the future search for a more efficient, more accurate and less time consuming computational procedure capable of predicting the temperature excursions under time varying conditions, a summary of current state-of-the-art of sixteen programs have been presented. The tabular summary will aid in the preliminary review and selection process. More meaningful comparison is difficult. It can be accomplished by detailed examination of code and by comparing the output of the problems having same identical input. Accuracy and computational times can also be compared. Pertinent comments related to the new SINDA which may be the tool of the future at NASA Laboratories is also presented.

The view factor to space and its importance in dissipating the energy in a thermal balance model of exposed orbiting equipment is important. Currently, this important view factor is being calculated by subtracting all the other view factors from a surface to the objects in the enclosure. This approach imposes tremendous burden on the computer-aided procedures used in calculating all the individual view factor very accurately. Such an accuracy is tied up with the value of dA/r^2 (FFACC - form factor accuracy) factor selected in the double summation method of the view factor calculations. Besides the Monte Carlo method this method is the only other procedure currently available for complex enclosures. When there is a common edge the FFACC criterion cannot be locally met causing global inaccuracies. References have been made to such situations. New and

novel approaches should be sought in order to improve global accuracies without undue expenditure of computational times.

In a complex enclosure such as exposed orbiting space equipment, the calculation of view factors is complicated by the presence of occluded surfaces. At present, considerable amount of time is being spent (about 50%) in identifying such situations. However, the layout of such objects in a mission is fixed. This thought suggests the possibility of developing shadow table and making use of the information in rapidly evaluating the geometric view factors. Reference has been made suggesting significant reduction in computational time. At present, Monte Carlo method is considered too slow and time consuming. It may be competitive when there are 1000 or more modal points. However, there are several time saving techniques and modification to basic procedure itself that are available. In the future there is the potential to successfully use this method for fast and accurate computations in a complex enclosure having non-Lambertian surfaces. In this report a comparison between Monte Carlo method and TRASYS has been made. Similarly comparative advantages of finite element and finite difference methods are indicated.

Schemes to improve the accuracy while making every effort to reduce the computational time should be the future goal. They go hand-in-hand in space research because of the expected one-to-one correspondence between the predicted results and experimental observation. In order to achieve this realistic but elusive goal several ideas are worth considering.

In the evaluation of radiation view factors since the reciprocity relationships are satisfied, every effort should be made to calculate the larger of the two view factors between the two surfaces. Computer programs should have such an intelligence.

It should be possible to recognize those surfaces and surfaces to planets or space which exchange significant energy and calculate these view factors rather accurately. Surfaces having common edge should be avoided or integrated, particularly if their thermal conditions are similar.

Where possible less time consuming contour integration, Hottel's stretch film method should replace slow double summation method. Here it may be possible to reduce the complex enclosure to a number of simple enclosures containing real plano-convex surfaces and artificially introduced plane surfaces covering the concave enclosures. The radiation streaming across these artificially created surfaces can be used as subsidiary surfaces whose thermal balances with respect to enclosed cavity can be completed. The potential of such an implosion or inward travel leading to real surfaces will improve the global accuracy of the results.

The view factors related to the earth's albedo, the sprawling space and the sun are important in the energy circulations. A method to directly calculate these view factors should be explored. Recognize that the view factor from the elemental space to the hemispherical enclosure is unity. Depending on the accuracy of the form (view) factor, it should be possible to construct a number of rays emitting from the centroid of the element towards the hemispherical space above it. Each ray can be traced in order and a record of the surface (including sprawling space, the earth's albedo and the sun) it touches can be kept. Such an accumulation of information will simultaneously evaluate all the differential

view factors (See Eq. 2) $F_{dA_i-A_j}$ satisfying their sum to be unity. This is identical to Herman - Nusselt projection (unit sphere) method which is the basis for number of experimental devices determining such a differential view factor. Here, this procedure can be computerized. The differential view factors from each element of a surface can be weighted according to the area of the elements themselves in order to evaluate F_{ij} , the finite view factors. The availability of computer graphics and the abilities of computers to project surfaces will greatly aid in the success of this procedure.

At a future date Monte Carlo procedure may be integrated with the above mentioned ray tracing method which will not only preserve the rather accurate view factor evaluation but also integrate the rather accurate energy balance consideration required in problems of space exploration. In this connection the potentials of the improved Monte Carlo method (Emery's Exodus method and the time saver techniques of Modest) should be thoroughly explored.

A subset of available computer program for heat transfer analysis based on Noor's work, presented here, and the information contained therein will aid in preliminary selection of a program or two for detailed study. The architect of SINDA (Mr. J. D. Gaski, SINDA Industries, Inc.) after almost ten years of obscurity, is in the process of completing New SINDA. It is scheduled to be reviewed by NASA/JSC and based on their judgment, it will be made available to all NASA centers. It should be of interest to closely scrutinize the improvisation contained in the theoretical manual of New SINDA against the number of recommendations suggested here. Such a scrutiny with our active participation will pave the way to hybrid all the available techniques in order to arrive at efficient and accurate techniques for thermal analyses simultaneously reducing the computational and turn-around times currently being posted.

REFERENCES

1. Chung, T. J., "Finite Element Analysis in Fluid Dynamics," McGraw Hill Book Company (1978)
2. Chung, T. J., "Radiation View Factors by Finite Elements," to appear in Journal of Heat Transfer ASME (1982)
3. Dixon, Sidney, (Moderator), "Panel Discussion - Concerns, Issues, and Future Directions (In Computational Aspects of Heat Transfer Structures)," Proceedings of a Symposium held at NASA Langley Research Center, Hampton, VA, NASA CP 2216, pp.453-486, Nov. 3-5, 1981
4. Eckert, E., "Bestimmung des Winkelverhältnisses beim 'Strahlungsaustausch durch das Lichtbild" Z. Ver. deut. Ing. Vol. 79, pp. 1495-6, (1935)
5. Eckert, E. R. G. and R. M. Drake, Jr., "Heat and Mass Transfer," McGraw Hill Book Company (1959)
6. Edwards, D. K., "Radiation Heat Transfer Notes," Hemisphere Publishing Corporation, (1981)
7. Emery, A. F. and W. W. Carson, "A Modification to the Monte Carlo Method - The Exodus Method," Transaction of ASME, Journal of Heat Transfer, Vol. 90, No. 3, pp. 328-332, August 1968
8. Emery, A. F., H. R. Mortazavi, "A Comparison of the Finite Difference and Finite Element Methods for Heat Transfer Calculations," Proceedings of a Symposium on Computational Aspects of Heat Transfer in Structures, Held at NASA Langley Research Center, Hampton, VA., NASA CP2216, pp. 51-82, Nov. 3-5, 1981
9. Emery, A. F., H. R. Mortazavi, and C. J. Kippenhan, "Interactive Computation of Radiation View Factors," Proceedings of a Symposium on Computational Aspects of Heat Transfer in Structures, ibid, pp. 221-241, Nov. 3-5, 1981
10. England, F. and H. O. Croft, "Radiation Configuration Factors Using Light in Furnace Models," Transactions of ASME, Vol. 64, pp. 691-702 (1942)
11. Farrell, R., "Determination of Configuration Factors of Irregular Shape," Journal of Heat Transfer, Trans C., ASME, Vol. 96, pp. 311-313, May 1976
12. Feingold, A., "Radiation - Interchange Configuration Factors Between Various Selected Plane Surfaces," Proc. Royal Society of London, Series A Vol. 292, No. 1428, pp. 51-60 (1966)
13. Gebhart, B., "Heat Transfer," McGraw Hill Book Company (1961)
14. Hamilton, D. C., and W. R. Morgan, "Radian Interchange Configuration Factors," NACA TN 2836 (1952)
15. Herman, R. A., "Treatise of Geometric Optics," Cambridge University Press, (1900)

16. Hickman, R. S., "Determination of Radiation Configuration Factors," Jet Propulsion Laboratory Technical Report No. 32-154, December 1961
17. Hottel, H. C., "Radiation Heat Transmission Between Surfaces Separated by Non-Absorbing Media," Transactions of ASME, Vol. 53, pp. 265-273 (1931)
18. Hottel, H. C., "Radiant Heat Transmission" in William H. McAdams (ed.), "Heat Transmission" 3rd Ed., Ch. 4, McGraw Hill Book Company (1954)
19. Hottel, H. C. and A. F. Sarofim, "Radiative Transfer," McGraw Hill Book Company (1967)
20. Howell, J. R., "Application of Monte Carlo to Heat Transfer Problems," Advances in Heat Transfer, Vol 5, Edited by T. F. Igvine, Jr. and J. P. Hartnett Academic Press, pp. 1-54 (1968)
21. Jakob, Max, "Heat Transfer," Vol. II, John Wiley and Sons (1957)
22. Jakob, Max and G. A. Hawkins, "A Model of Photographic and Photometric Determination of Heat Radiation Between Surfaces and Through Absorbing Gases," Journal of Applied Physics, Vol. 13, pp. 246-254 (1942)
23. Klahr, C. N., "A Monte Carlo Method for the Solution of Elliptic Partial Differential Equations," in Mathematical Methods for Digital Computers," Eds. Ralston A. and H. Wilf, John Wiley and Sons (1960)
24. Modest, M. F., "Three-Dimensional Radiative Exchange Factors for Nongray Nondiffuse Surfaces," Numerical Heat Transfer, Vol. 1, pp. 403-416 (1978)
25. Modest, M. F. and S. C. Poon, "Determination of Three-Dimensional Radiative Exchange Factors for the Space Shuttle by Monte Carlo," ASME Paper 77-HT-49, (1977)
26. Myers, Glen E., "Analytical Methods in Conduction Heat Transfer," McGraw Hill Book Company (1971)
27. Noor, Ahmed K., "Survey of Computer Programs for Heat Transfer Analysis," Proceeding of a Symposium on Computational Aspects of Heat Transfer in Structures, Held at NASA Langley Research Center, Hampton, VA, NASA CP2216 pp. 487-561, Nov. 3-5, 1981
28. Nusselt, Wilhelm, "Graphische Bestimmung des Winkelverhältnisses bei der Wamstrahlung," VDI Z., Vol. 72, p. 673 (1928)
29. Oppenheim, A. K., "Radiation Analysis by the Network Method," Transactions of ASME, Vol. 78, pp. 725-735 (1956)
30. Paschkis, V., Electrotech and Maschinenbau, Vol. 54, p. 617 (1936)
31. Patterson, W. C., Letters of Communications about NEW SINDA - by J. D. Gaski, SINDA Industries, Inc., P. O. Box 8007, Fountain Valley, CA, 92708 (1982)

32. Sawyer, Patricia, L., "Numerical Procedure to Determine Geometric View Factors for Surfaces Occluded by Cylinders," NASA TM-78740, Langley Research Center, Hampton, VA (1978)
33. Scheps, P. R. and H. R. Howell, "The Effect of Radiation Trapping within the Sepcular Cavity Formed by the Shuttle Forward Radiator and Payload Bay Door," ASME Paper 76-ENAS-55 (1976)
34. Seibert, O., Archiv fuer Waermewirtschaft, Vol. 9, p. 180 (1928)
35. SINDA, "Systems Improved Numerical Differencing Analyzer," User's Manual, Prepared by James P. Smith of TRW for NASA Manned Spacecraft Center, Under Contract NAS 9-10435, April 1971
36. Sowell, E. F., "Environmental Radiation from Fluorescent Ceiling Systems," PhD Dissertation, University of California, Los Angeles, CA, March 1972
37. Sowell, E. F. and P. F. O'Brien, "Efficient Computation of Radiant - Interchange Configuration Factors within the Enclosure," Journal of Heat Transfer, Series C, Trans. of ASME, Vol. 94, pp. 326-328, August 1972
38. Sparrow, E. M., "On the Calculation of Radiant Interchange Between Surfaces," Modern Developments in Heat Transfer, Edited by Warren Ibele, Academic Press, (1963)
39. Sparrow, E. M. and R. D. Cess, "Radiation Heat Transfer," Hemisphere Publishing Corp./McGraw Hill Book Company (1978)
40. Toups, K. A., "A General Computer Program for the Determination of Radiant - Interchange Configuration and Form Factors - CONFAC II," North American Aviation Inc., Space and Information Systems Division, SID Report 65-1043-2, (1965)
41. TRASYS, "Thermal Radiation Analysis System," Developed by Martin Marietta under Contract NAS9-13033, (1973)
42. TRASYS II, "Thermal Radiation Analysis System," Users Manual developed under Contract NAS9-14318 by Martin Marietta, MCR-730105 (Revision 1) August 1977
43. Turner, L. D., W. R. Humphries, and J. W. Littles, "Effect of Specular Orbiter Forward Radiation on Typical Spacelab Payload Thermal Environment," AIAA-81-1074, AIAA 10th Thermophysics Conference, Palo Alto, CA, June 23-25, 1981
44. Vogt, Robert A., "Recent Developments in Thermal Radiation System Analyzer (TRASYS)," Proceedings of a Symposium on Computational Aspects of Heat Transfer in Structures, Held at NASA Langley Research Center, Hampton, VA, NASA CP2216, pp. 243-251, Nov. 3-5, 1981
45. Wiebelt, J. A., "Configuration Factors for Radiation Heat Transfer Analysis when Surfaces Partially Occlude Other Surfaces," AIAA Paper No. 72-304, AIAA 7th Thermophysics Conference, San Antonio, TX, April 10-12, 1972
46. Wu, S. T., R. E. Ferguson, and L. L. Altgilbers, "Application of Finite - Element Techniques to the Interaction of Conduction and Radiation in an Absorbing, Scattering and Emitting Medium," AIAA-80-1486, 15th Thermophysics Conference, AIAA, Snowmass, Colorado, July 14-16, 1980. Also see MSFC/NASA Report done under Contract NAS8-28097.

APPENDIX

View Factor Calculations Using TRASYS*:

The computer program TRASYS used in the determination of form (view) factor utilizes form factor accuracy (FFACC) along with the double summation method. In order to compare the accuracy of the calculations as well as the computational time, two standard problems have been selected. One of them is view factor between a pair of infinite strips having a common edge with included angles of 60° or 90° . The solution to this problem is provided by Hamilton and Morgan (1952) and the revised calculated values by Feingold (1966). The other problem is view factor between a pair of infinitely long parallel cylinders. In order to accommodate these problems in the TRASYS program the length of common edge or the length of the axes had to be finite. Hence, these length dimensions were made sufficiently large in order to assure two-dimensional character of the problem.

Table A-1 compares the results of TRASYS run for the two rectangular strips having a common edge with that of results of Feingold. The form factor accuracy, $FFACC = 0.03$ has been used for the first six cases. The dimensions of the strips as well as the angle between them are also shown in the table. The numerical results of Feingold is available only for the first two cases. The TRASYS values are higher than Feingold's results. They should have been a shade less than Feingold's results because of the end effects on view factors. The differences are 4.2 and 13.6 percent higher than actual values. Considering that on an average there is more influence of common edge effect in case 2 compared to case 1, the trend of departure in the error is to be expected. Table A-1 contains CPU seconds used in each of these calculations. As the angle between the strips decreases it is expected that CPU seconds will increase and the departure from true values will also increase. The cases selected did not provide a direct comparison to demonstrate the above conclusion.

The results of the test cases 3-1 through 6-1 shown in Table A-1 are for $FFACC = 0.05$. As to be expected the view factor calculation with $FFACC = 0.05$ will consider larger minimum element size than that with $FFACC = 0.03$. The trend in the larger view factor seems to be expected recognizing greater error associated with higher value of $FFACC$. There has been considerable reduction in CPU time with larger $FFACC$ which is to be expected.

Examination of view factors for the test cases 3 through 6 indicates that they are too high and the test case 4 posting a view factor greater than unity. This is impossible. The choice of parameters for these cases did not permit direct comparison with Feingold's results. It is expected that these view factors to be less than 0.67. Hence this comparative study is inconclusive.

* The supporting computational work was provided by Ms. Kathy Upshaw, Life Support and Environmental Branch, Engineering Analysis Division, Structures and Propulsion Laboratory, Marshall Space Flight Center, NASA.

*TABLE A-1: View Factors Between Two Rectangular Strips having a Common Edge.

Test Case	Area A_1	Area A_2	Angle of Contact Deg.	Form Factor	CPU Secs	Feingold Results Form Factor	Difference Percent
1	6 x 300	60 x 300	90	0.4858	2.026	0.4662	4.2
2	6 x 300	15 x 300	90	0.4534	2.151	0.3991	13.6
3	3 x 300	6 x 300	60	0.8155	11.0	-	-
4	1.2 x 120	6 x 120	60	1.1947	1.9	-	-
5	0.3 x 300	6 x 300	60	0.9492	4.54	-	-
6	0.3 x 120	6 x 120	60	0.9449	1.46	-	-
3A				0.8647	4.93		
4A				1.206	1.74		
5A				0.9493	4.54		
6A				0.9453	0.935		

* FFACC = 0.03 for Test Cases 1 through 6 and
 FFACC = 0.05 for Test Cases 3A through 6A.

Table A-2 compares the results of TRASYS run for the two cylinders having parallel axes with that of the values evaluated using the equation based on Hottel's crossed-string method. In this report, the solutions are represented by Eq. 23 for the case of cylinders of equal radii and Eq. 24 is for the cylinders having unequal radii. In Eq. 24

$$\phi_1 = \alpha - \beta, \quad \phi_2 = \alpha + \beta, \quad \alpha = \sin^{-1} \left(\frac{R_1 + R_2}{C} \right)$$

and $\beta = \sin^{-1} \frac{R_1 - R_2}{C}$ and $R_1 > R_2$ and C is the distance between the two centers.

Agreement between the TRASYS and Hottel's methods for the case of parallel cylinders is not at all satisfactory. For the same value of FFACC as the cylinder moved apart the TRASYS program is supposed to permit use of coarser grid and consequently smaller values of CPU seconds. That trend seems to be true for unequal cylinders but not for equal cylinders. Another group of comparative cases that can be considered are semi-cylinders with the curved portions facing each other. Here the view factor between the curved portion of the smaller semi-cylinder to the curved portion of the larger semi-cylinder should be slightly smaller than the corresponding full cylinders. It should be possible to evaluate the view factors when the two cylinders share a common line contact.

Hottel's crossed-string method permits easy derivation of equations for the exact values of view factors for a number of two dimensional cases. Each one of them could be test cases for TRASYS program. These examples could cover occluded surfaces for which the derivations are possible. Hence, it is possible to construct a number of test cases for TRASYS program and study systematically the effect FFACC and CPU time used in converging on correct answers as provided by the closed form solutions. Such a study will enhance the efficient use of TRASYS program and through understanding of the future modifications that are in the wings.

*TABLE A-2: View Factors Between Two Cylinders having their Axes Parallel

Test Case	Radii		Center Distance C	TRASYS		Hottel's Crossed String Method Form Factor
	R ₁	R ₂		Form Factor	CPU Secs	
1	1	1	4	0.3192	9.263	0.16275
2	1	1	6	0.2108	12.683	0.10712
3	2	1	8	0.155	9.094	0.04033
4	2	1	12	0.103	7.390	0.02668
5	5	1	30	0.1854	3.184	0.01304

* FFACC = 0.05 in all these Cases.