

NASA
CR
3295
c.1

NASA Contractor Report 3295

LOAN COPY
AFW/T/TECHNI
KIRTLAND AF



Selected Advanced Aerodynamics and Active Controls Technology Concepts Development on a Derivative B-747 Aircraft Summary Report

Staff of Boeing Commercial Airplane Company

CONTRACT NAS1-14741
JUNE 1980

FOR EARLY DOMESTIC DISSEMINATION

Because of its significant early commercial potential, this information, which has been developed under a U.S. Government program, is being disseminated within the United States in advance of general publication. This information may be duplicated and used by the recipient with the express limitation that it not be published. Release of this information to other domestic parties by the recipient shall be made subject to these limitations.

Foreign release may be made only with prior NASA approval and appropriate export licenses. This legend shall be marked on any reproduction of this information in whole or in part.



Date for general release June 1982



NASA Contractor Report 3295

Selected Advanced Aerodynamics
and Active Controls Technology
Concepts Development on a
Derivative B-747 Aircraft

Summary Report

Staff of Boeing Commercial Airplane Company
The Boeing Commercial Airplane Company
Seattle, Washington

Prepared for
Langley Research Center
under Contract NAS1-14741



National Aeronautics
and Space Administration

**Scientific and Technical
Information Office**

1980

FOREWORD

This document constitutes the summary report of work conducted under NASA Contract NAS1-14741 during the period May 1977 through May 1979. The contract was managed by the NASA Energy Efficient Transport Office (EETPO) headed by Mr. W. J. Alford - a part of the AirCRAFT Energy Efficiency (ACEE) Program organization at the Langley Research Center. Mr. D. B. Middleton of the EETPO was the Technical Monitor for the contract. The work was performed within the Product Development organization of the Boeing Commercial Airplane Company, 747 Division. Key Contractor management personnel responsible for the contract work were:

G. W. Hanks	Program Manager
R. L. Allison	Project Manager
M. A. Booth	747 Technology
R. H. Weiland	747 Design
A. H. Eldridge	Aerodynamics Technology
D. E. Chichester	Flight Controls Technology
J. R. Fuller	Structures Technology
B. R. Perkin	Structures Technology
D. W. Abrams	Weights Technology

Principal measurements and calculations used during these studies were in customary units.

CONTENTS

	<u>Page</u>
SUMMARY	1
PROGRAM OBJECTIVE	4
PROGRAM SCOPE	6
WING TIP EXTENSIONS	8
WING TIP WINGLETS	12
WING LOAD ALLEVIATION	20
WING STRUCTURE MODIFICATIONS	28
WEIGHT IMPACT	32
FINAL EVALUATION	34
REFERENCE	46

SUMMARY

Under the NASA EET Program Phase I contract, wing tip extensions, wing tip winglets, and the use of active outboard ailerons for wing load alleviation were studied as possible ways to improve fuel efficiency for the Boeing 747. The general approach was to improve the cruise lift to drag ratio (L/D) by means of wing tip modifications while using a wing load alleviation system to minimize the associated structural weight increase. Details of the work conducted under the contract are contained in NASA CR-3164 (ref. 1).

Wing Tip Modifications--Two wing tip extension designs, 1.83m (6 ft) and 3.66m (12 ft), were evaluated. Previous testing has shown the wing with either tip extension to be flutter free. Aerodynamic design and high speed wind tunnel testing were accomplished for five winglet configurations. One of the winglet designs showed 96% of the potential drag improvement predicted by subsonic flow theory. A 3.2% increase in full-scale, maximum trimmed L/D was estimated. Flutter testing of the winglet disclosed a symmetric flutter mode and a wing tip flutter mode, due primarily to aerodynamic rather than mass effects. A significant flutter weight penalty resulted. Winglets achieve slightly more L/D improvement than a tip extension having the same panel, but result in less increase in wing semispan (gate clearance) and lower bending moments on the inboard portions of the wing.

Wing Load Alleviation--Effectiveness of the outboard low-speed ailerons as wing load alleviation surfaces was determined by means of high-speed wind tunnel model (0.03 scale) testing and aeroelastic analyses. These ailerons introduce wing torsion loads but are effective in reducing wing bending moments. A balance tab on the aileron was evaluated as a means of reducing wing torsion, but the present untabbed aileron proved to be the best overall approach and was selected. A net airplane operating empty weight (OEW) reduction equivalent to 2% of the wing structural box weight could be achieved by resizing the wing structure to take advantage of maneuver load alleviation capability. A further 0.5% reduction could be achieved through gust load alleviation. The improvement in fuel efficiency attributable to maneuver load alleviation, was estimated to be 0.2%. Wing acceleration was the only feedback parameter retained in the final control law and which provided elastic mode suppression of the first wing bending mode. A fail-operational mechanization concept was selected that included redundancy to yield estimated reliability approaching that of a dual yaw damper system. Structural safety margins, though reduced, are adequate with the system failed.

Wing Tip Modifications Combined With Wing Load Alleviation--A 1.83m (6-ft) wing tip extension and the best winglet were analyzed in combination with symmetrically deflected outboard ailerons. With aeroelastic effects included, maneuver load alleviation capability was greater for the winglet than for the tip extension. However, requirements for increased flutter material were found to offset the apparent advantage in ultimate load sizing. A flutter mode control system (of no benefit with tip extensions) would be beneficial with winglets, but would require an extensive development and test program.

Fuel Savings--Block fuel savings data were computed as a function of range with fixed payload. The fuel savings attributable to the individual concepts (fig. 1) indicate the winglet is the most attractive from the standpoint of fuel use reduction. Further reduction due to addition of wing load alleviation is considerably less than that for the tip modifications.

Economic Comparisons--Tip extension or winglet retrofit appears impractical with or without wing load alleviation. With amortization of development and engineering flight test program costs excluded, winglet production costs are about three times that of a 1.83-m (6-ft) tip extension due to the larger size and increased complexity. Wing load alleviation system cost, if installed in combination with a tip modification, is about one-third that of a 1.83-m (6-ft) tip extension.

Return on investment comparisons, as a function of market base for a typical 1978 fuel price, are shown in Figure 2. Escalation of fuel prices relative to the general inflation rate did not alter the selection of the best configuration. The most economically attractive study configuration was a 1.83-m (6-ft) tip extension, without a wing load alleviation system. The return for the wing load alleviation system could be more favorable for other specific 747 applications, or for airplanes designed for outboard aileron actuation at high speeds.

Conclusions and Phase II Recommendations--The winglet has excellent potential for fuel savings, particularly in combination with a wing load alleviation and flutter mode control system, but it appears doubtful that recurring production costs for the winglet could be reduced sufficiently to become economically competitive with a simple wing tip extension for the Model 747. Although the 1.83m (6-ft) tip extension offered only approximately 60% of the fuel reduction potential shown by the winglet, the tip extension was the only candidate concept offering operating economics that would provide an acceptable return to the airlines. The tip extension continued to show this advantage at relatively high fuel prices, and was judged a viable candidate for incorporation during normal growth of the Model 747.

Flight testing of maneuver and gust load alleviation concepts has been accomplished on the 747 as part of a separate Boeing-funded IR&D program and, in combination with a tip extension, on the L-1011 as part of the NASA EET program. No further NASA-funded research appears necessary for tip extensions. Near-term commercial application of winglets to the B-747 appears unlikely. As a result, no NASA/Boeing EET Phase II work is recommended in these technical areas for the 747.

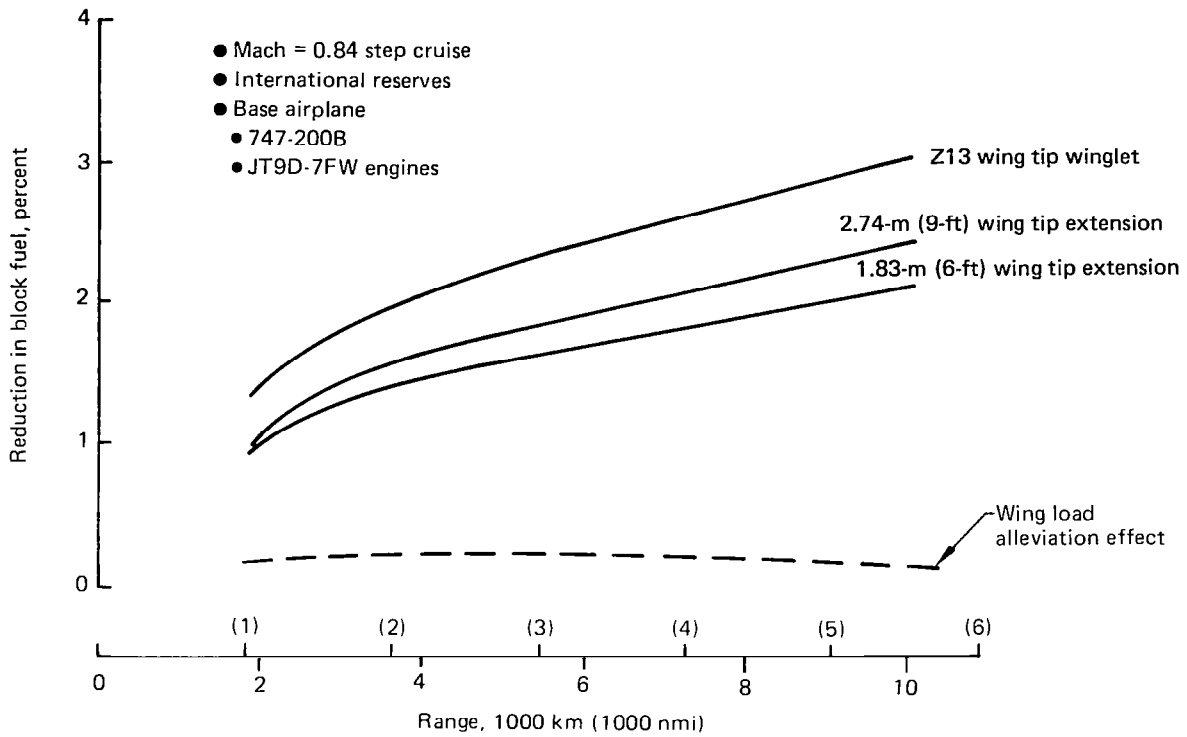

Figure 1. Block Fuel Savings

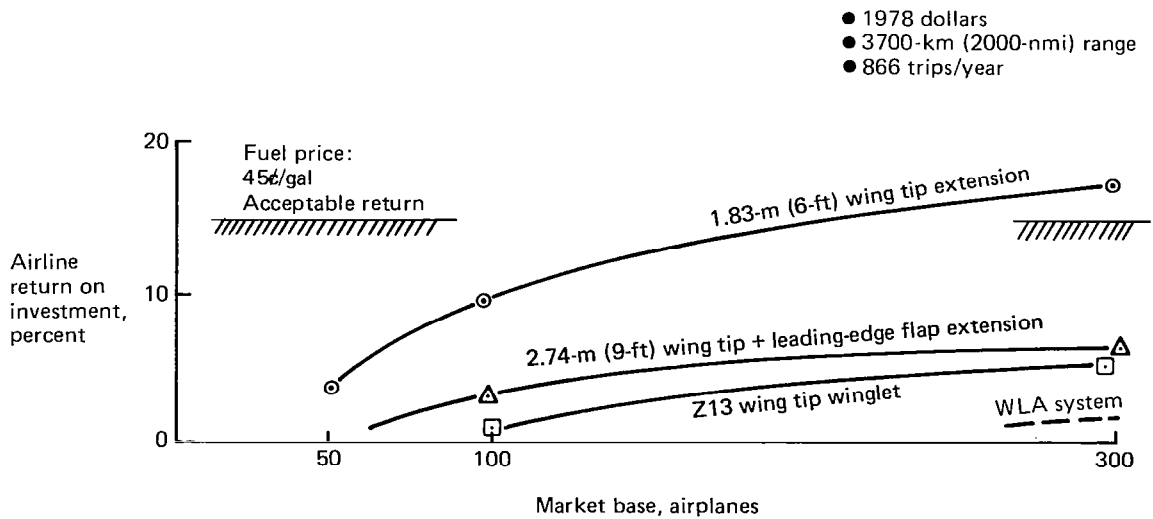

Figure 2. After Tax Return on Modification Investment

PROGRAM OBJECTIVE

This study was conducted as part of the NASA-LRC Energy Efficient Transport (EET) element of the Aircraft Energy Efficiency (ACEE) program. The overall objective of the ACEE program is to improve the fuel efficiency of air transportation to conserve petroleum fuel. The 747 EET program was planned for accomplishment in two phases. The first phase, a 2-year study program, was completed as summarized in this report. Details are contained in Reference 1. Concepts identified as having potential for near-term commercial fleet implementation were to be identified in the Phase I study. Although continuation of the 747 EET program into Phase II has not been recommended, a valuable data base has been generated that can continue to be used for reference.

OBJECTIVE

Specific objectives of the 747 Phase I study, reported herein, were to 1) examine feasibility, benefits, and costs of wing tip extensions (WTE), wing tip winglets (WTW), and a wing load alleviation (WLA) system employing active outboard ailerons, and 2) make a recommendation regarding continuation of the program into Phase II. The study concepts, illustrated in Figure 3, were to be analyzed individually and in combination to the following ground rules:

Baseline Airplane--A representative passenger model 747-200B configuration was defined as the baseline airplane. At operating weights, the baseline wing has positive structural margins of safety at design load conditions.

Basic Wing Geometry--To minimize changes to production tooling, no changes in wing planform, airfoil section, or jig twist were allowed inboard of the tip modification. The requirement to retain jig twist is an important distinction between studies of tip extensions and new wings with increased span, since jig twist could be revised to optimize cruise twist for a new wing.

Flight Envelope--No changes to the speed/altitude/maneuver envelope were allowed.

Performance Comparisons--Fuel efficiency was expressed in terms of block fuel savings for a given range with a fixed payload. The maximum taxi weight was unchanged although the operating empty weight was modified to reflect the structural/system weight changes for the various concepts.

WLA Control Surface--Consideration was restricted to the outboard aileron as the primary wing load control surface. The elevators were used to compensate pitching moments introduced by the ailerons; their application to add pitch damping for GLA also was considered.

747-200B baseline

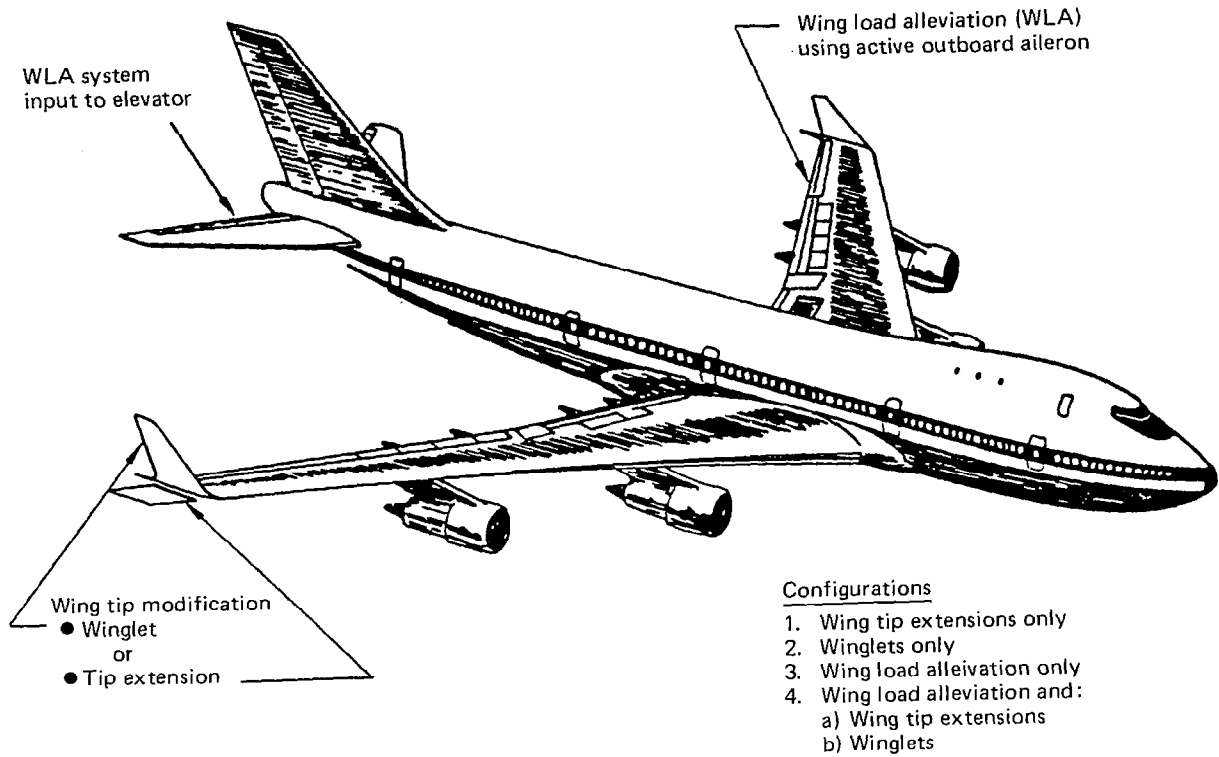

Figure 3. Study Configurations

PROGRAM SCOPE

Figure 4 illustrates the scope of the Phase I program. The 2-year study program consisted of analyses and wind tunnel tests. No flight testing was conducted and, apart from wind tunnel model parts, no hardware was developed. Emphasis was on those factors that would affect the economic trades (e.g., lift to drag ratio (L/D), structural weight, system reliability, and general design complexity), rather than on detailed structural design or control system development, which were to be planned for Phase II.

The two high-speed wind tunnel tests were accomplished in the Boeing Transonic Wind Tunnel (BTWT) to obtain force and pressure data for winglets and for symmetrically deflected outboard ailerons. Low-speed configuration (flaps down) testing was deferred to Phase II. Flutter testing of winglets was accomplished in the University of Washington Aeronautical Laboratory (UWAL) and the Convair Aeronautical Laboratory (CVAL) using a low-speed flutter model dynamically scaled to represent high-speed conditions.

Engineering analyses were conducted to determine loads, structural sizing (including flutter stiffness requirements), weights, L/D performance, and stability and control effects for the various concepts. Preliminary engineering design studies were accomplished to the extent necessary to develop conceptual layouts and work statements for pricing and to support the analytical effort.

Production costs were estimated. Price curves based on these costs were used in addition to performance estimates to determine airline return on investment. Technical and economics data were considered in making the Phase II recommendations.

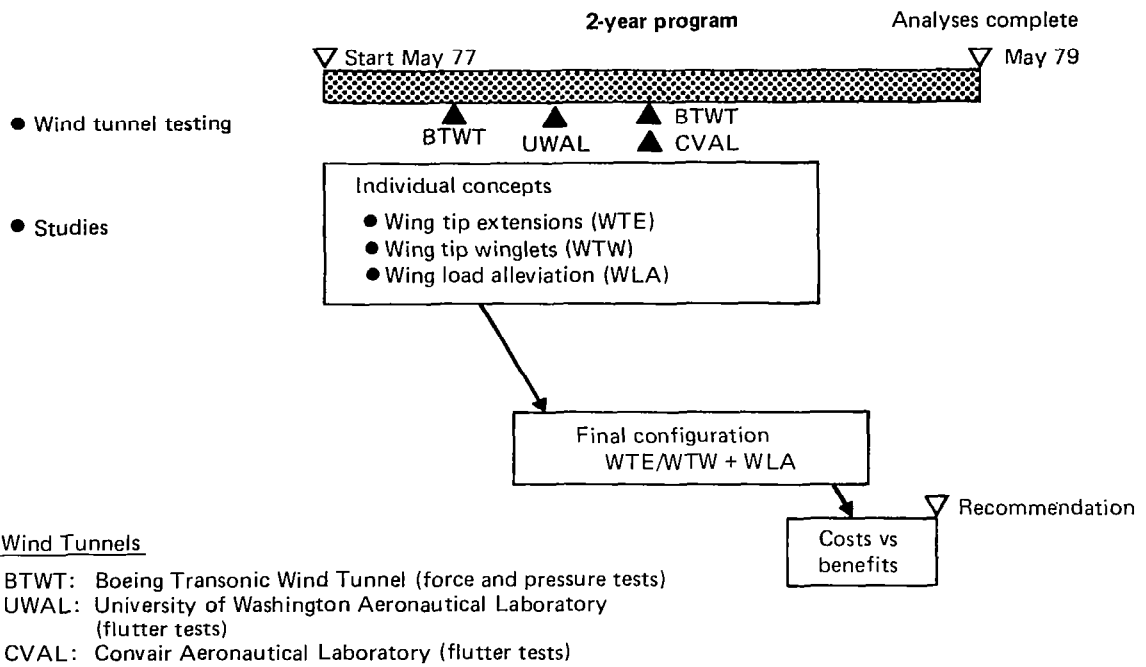

Figure 4. Program Outline

WING TIP EXTENSIONS

CANDIDATE DESIGNS

Two wing tip extensions (WTE) were analyzed in detail. One was a 1.83-m (6-ft) WTE previously tested in a Boeing High-Speed Wind Tunnel test. The second was a 3.66-m (12-ft) WTE selected for analysis on the basis of preliminary (quick-look) trend studies that considered flutter and the effects of increased aeroelastic washout on lift to drag ratio (L/D). Although L/D continues to increase for semispan increases to 3.66 m (12 ft,) the maximum studied, the detailed analyses showed net fuel efficiency to be little better for the 3.66-m (12-ft) WTE than for the 1.83-m (6-ft) WTE when structural weight effects also were included.

Based on results of the trend studies and subsequent detailed analyses, a 2.74-m (9-ft) WTE was selected as the optimum semispan increase for a WTE without wing load alleviation (WLA). A longer tip extension could be optimum with WLA, depending upon the extent to which the WLA system negates the added weight penalty. However, concerns regarding flutter, the need for leading-edge flaps, and gate/maintenance hangar access increase with the length of the WTE.

PRELIMINARY TREND STUDIES

The study plan called for detailed analyses of a 1.83-m (6-ft) WTE and an alternate WTE to determine net fuel efficiency improvement considering both L/D and weight effects. The purpose of the preliminary trend studies was to provide guidance in selecting the alternate configuration.

Prior studies had shown that aeroelastic washout negated much of the potential L/D benefit of a WTE. Hence, elastic wing twist was computed for 1.83-m (6-ft) and 3.66-m (12-ft) extensions. Baseline wing stiffness was assumed; i.e., no structural resizing for the twist calculation nor for the preliminary flutter trend analyses.

The configurations analyzed for the trend study are shown on Figures 5 and 6. The 1.83-m (6-ft) tip extension has a constant chord, thickness, and jig twist that are the same as the existing 747 wing section at wing buttock line (WBL) 1169. The 3.66-m (12-ft) tip extension has a constant thickness/chord ratio and jig twist that are the same as the existing wing section at WBL 1169, but has a tapered chord. Aerodynamically, differences due to a tapered planform versus constant chord planform were found to be negligible for the 1.83-m (6-ft) tip.

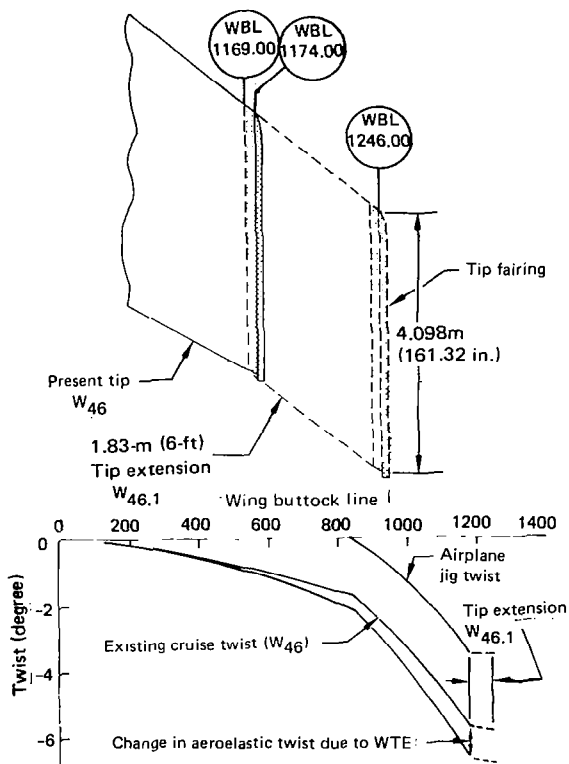

Figure 5. 1.83-m (6-ft) Wing Tip Extension Geometry

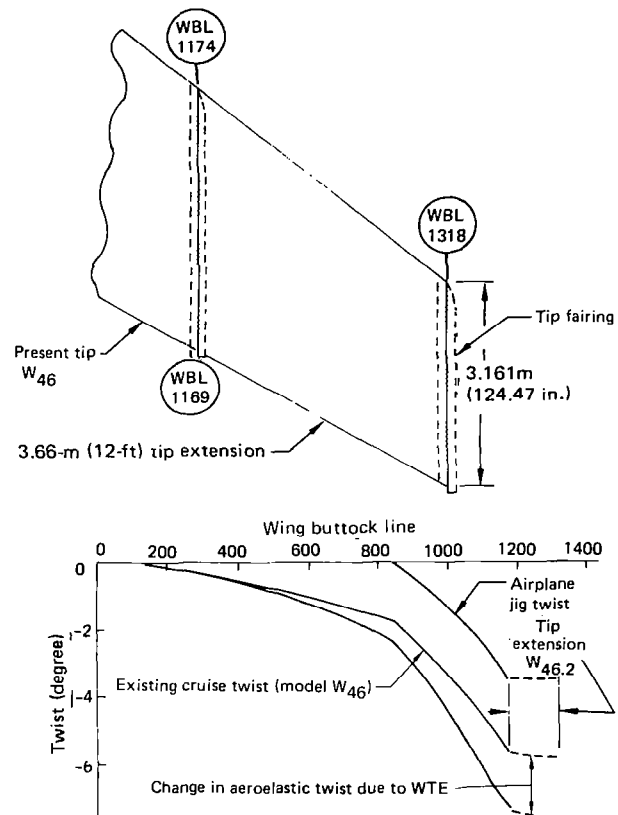

Figure 6. 3.66-m (12-ft) Wing Tip Extension Geometry

WING TIP EXTENSIONS

WEIGHT AND PERFORMANCE TRENDS

In general, detailed analyses to determine fuel savings offered by addition of wing tip extensions consisted of loads definition and ultimate and fatigue sizing, based upon comprehensive sets of design loads, flutter stability checks, cruise twist, and weights estimates for the resized wing. The lift to drag (L/D) computation accounted for twist effects. The structural loads and sizing cycle was abbreviated for the 3.66-m (12-ft) WTE since it offered only slightly more fuel savings than the 1.83-m (6-ft) WTE. The effects of tip extensions on stability and control and on the flight control system were determined only for the 1.83-m (6-ft) WTE. Preliminary design studies concerned with the tip attachment concept and equipment relocation, which formed a basis for cost estimation, also concentrated on the 1.83-m (6-ft) WTE. In these areas, considerable background information and drawings were available from prior studies. Additional wing stiffness would not be required for the 1.83-m (6-ft) WTE.

WEIGHTS

Table 1 compares weight increments of the 1.83- and 3.66-m (6- and 12-ft) WTE for two design approaches with the existing margins of safety (MS) absorbed, and with the margins maintained. Wing tip extension panel and attachment weights were estimated from layout drawings. The weight build-up of the 1.83-m (6-ft) extension is as follows:

	<u>Mass (Weight)/Airplane</u>	
	<u>kg</u>	<u>lb</u>
Extension of wing box	243	(535)
Extension of leading edge (no leading-edge device)	82	(180)
Extension of trailing edge	38	(84)
Additional access doors	7	(16)
Deletions from baseline	-54	(-120)
Miscellany and round off	<u>2</u>	<u>(5)</u>
Total 1.83 (6-ft) WTE =	318	(700)

PERFORMANCE TRENDS

Figure 7 shows percent increase in $(L/D)_{\max}$ as a function of length of the tip extension. The L/D equivalent of the increased operating empty weight (OEW) is based on trade factors valid for nontakeoff gross weight limited missions (e.g., 5556 km (3000 nmi)). Net $(L/D)_{\max}$ indicates that a 2.74-m (9-ft) tip extension is near optimum.

Table 1. Wing Tip Extension (WTE) Weight Summary

	Increment per airplane, mass (weight), kg (lb)			
	1.83-m (6-ft) WTE		3.66-m (12-ft) WTE	
	Absorb existing margin of safety	Maintain existing margin of safety	Absorb existing margin of safety	Maintain existing margin of safety
Wing tip installation	317 (700)	317 (700)	635 (1400)	635 (1400)
Wing box reinforcement for:				
● Static loads	190 (420)	1360 (3000)	1168 (2575)	2710 (5975)
● Fatigue	45 (100)	0 (0)	230 (500)	0 (0)
● Flutter	0	0	0	0
Total delta increase/airplane	553 (1220)	1678 (3700)	2030 (4475)	3345 (7375)

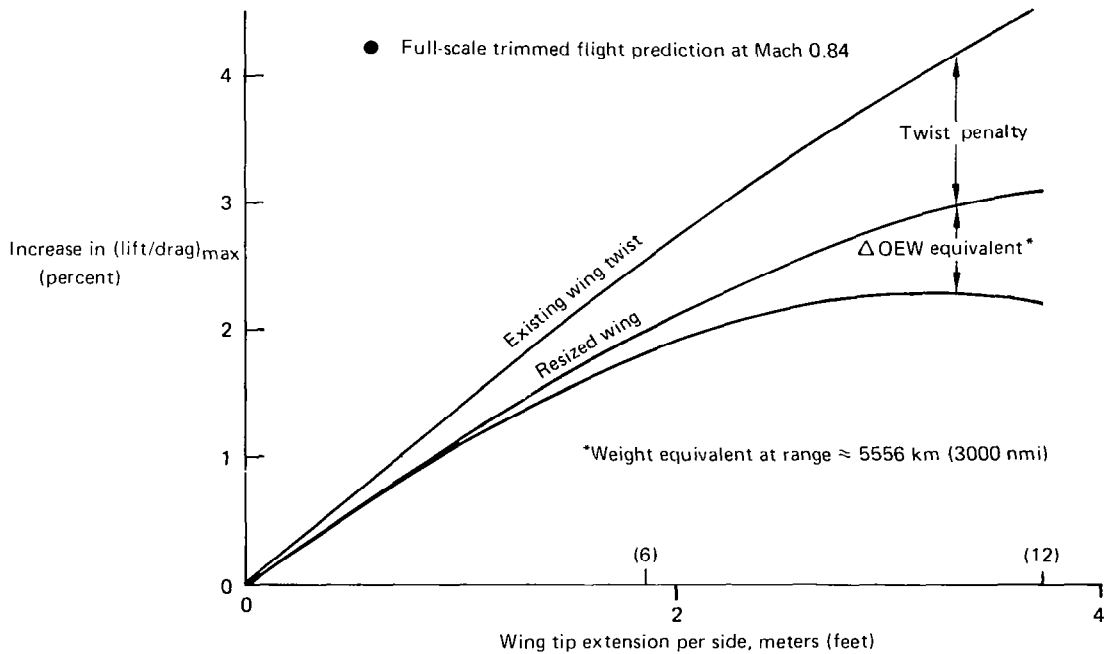

Figure 7. Performance Trends for Wing Tip Extensions (WTE)

WING TIP WINGLETS

CANDIDATE DESIGNS

Winglet studies similar to those for tip extensions were conducted. Four winglet designs, identified as Z9, Z11, Z12, and Z13, were investigated. Characteristics of the Z11, Z12, and Z13 designs are shown in Figure 8. The Z9 winglet was identical in planform to the Z13, but differed in cant angle, airfoil sections, and aerodynamic philosophy. The Z11 and Z12 designs differed only in cant angle, as shown, and were of shorter chord than the Z9 and Z13 designs. Detailed analysis was pursued to determine potential fuel savings for two configurations, Z9 and Z13, however, winglet studies required a much larger effort than the tip extension studies. It was necessary to design and test several winglets to achieve satisfactory performance. Flutter model testing was necessary and analytical tools had to be modified in the areas of aerodynamic design, loads, and flutter.

The winglet identified as Z9, did not perform satisfactorily during initial tests. Structural analyses for this configuration were, therefore, abbreviated. The winglet Z13 gave the best performance of the three configurations (Z11, Z12, and Z13) tested in the second test series, achieving 96% of its theoretical potential. Figure 8 shows the geometric characteristics and wind tunnel test versus predictions for the three configurations. Both Z11 and Z12 test performance fell well below predictions. The Z13 performed near predictions at cruise ($C_L = 0.45$, $M = 0.84$). A full-scale increase in maximum trimmed cruise L/D of 3.2% was estimated for the Z13 configuration.

Resource constraints required flutter model testing to be limited to the first winglet design (Z9) rather than the final (Z13). However, a range of cant angles was tested, which allowed adequate correlation of the final Z13 design. Flutter testing showed that the winglets caused a symmetric flutter mode and a wing tip flutter mode to appear that are not present for the baseline wing. Further testing showed the modes resulted from aerodynamic rather than mass effects. Flutter speeds with these modes were greatly reduced relative to that for the antisymmetric flutter mode of the baseline wing. These modes and the attendant reduction in flutter speed were not predicted by the conventional flutter analysis methods used prior to the winglet test. When the problem appeared, the flutter study plan was expanded to improve the winglet flutter analysis. The improved analysis gave a reasonable degree of correlation with the test results and was then used as part of the final structure sizing cycle for the Z13 winglet. Flutter sizing required addition of a significant amount of stiffness material. The added flutter weight, when translated in terms of equivalent L/D reduced the L/D benefits of the Z13 WTW by about 0.5%.

An initial design installation that used three steel fittings to attach the wing spars to the winglet spars was judged to be unsatisfactory for stress and manufacturing aspects. A later concept employing multiple spars in the wing/winglet juncture region was adopted for the final winglet (Z13) attachment design. Having a full-chord planform and a reasonable thickness to chord ratio, the Z13 was best with respect to wing/winglet attachment design.

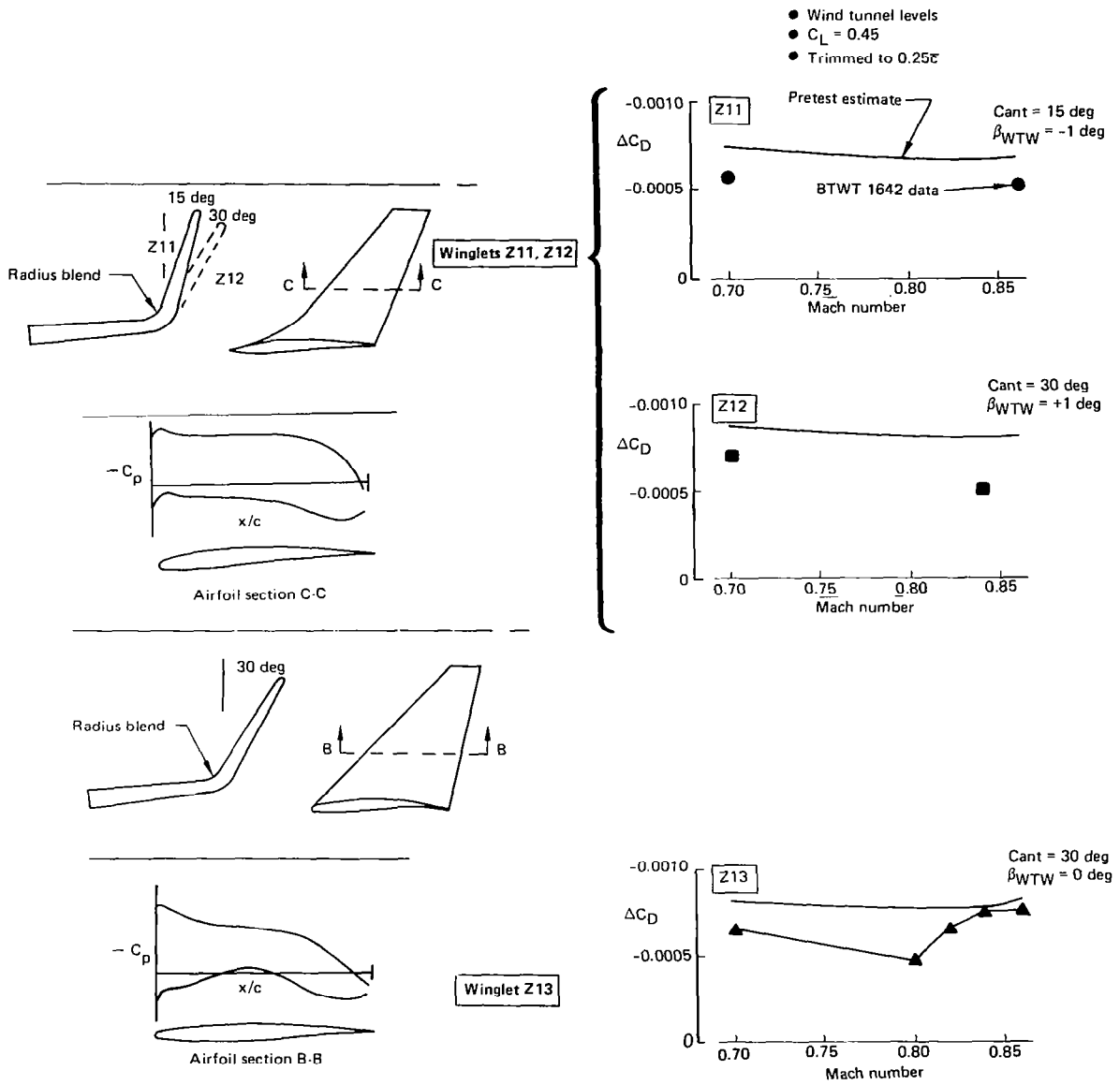

Figure 8. Candidate Winglets—Geometry and Test Results

WINGLET INSTALLATION

STRUCTURAL LOADS

Critical maneuver and fatigue conditions were analyzed for the wing with the Z13 winglet. The Z9 winglet was analyzed for design maneuver conditions only. The load results were processed to determine required stiffness increases and the analysis was cycled to determine the final load results. The aerodynamic forces used for the analysis were based on wind tunnel test data. Wing and winglet wind tunnel test pressures were measured for the Z9 winglet configuration and wing pressures only were measured for the Z13 winglet. The Z13 winglet forces were derived using the Z9 data.

Figure 9 shows the effect of the winglets on wing design bending moment. Figure 10 shows wing twist data for a typical cruise condition. The effect of the winglets is to increase wing bending moment over the outboard wing with a small reduction near the root and also to increase wing washout. The Z13 winglet, which had the larger cant angle, gave the highest wing loads and the most wing washout. The effect of increased stiffness for strength design was small since advantage was taken of existing excess wing structural margins, which were absorbed when the winglet was added.

A flutter analysis of the Z13 winglet configuration showed that a stiffness increase was required to prevent wing flutter. Final load and twist results for this stiffness are shown in Figures 9 and 10 for the Z13 winglet configuration. The bending moment reduction near the wing root does not occur when the wing is assumed rigid. Load reduction present at the root due to wing flexibility, is caused by a combination of aeroelastic effects. It was found that if existing wing structural margins were maintained rather than absorbed, a significantly higher load would result.

Local winglet loads were derived for design of the winglet to wing attachment fittings based on a limited survey of symmetric maneuver, lateral gust, and lateral maneuver conditions. The critical condition was a rudder maneuver II condition, as defined by FAR25.35(a)(3), which produced an ultimate design winglet pressure of 22 kN/m^2 (3.2 psi).

LIFT TO DRAG RATIO

Figure 10 also shows the percent increase in L/D at $C_L = 0.45$ for the Z9 and Z13 winglets prior to detailed flutter analysis. The L/D equivalent of the increased OEW (no flutter penalty) was obtained using trade factors which are valid for nontakeoff gross weight limited missions (e.g., 3000 nmi.) The superior performance of the Z13 winglet when compared to the Z9 winglet is evident. The Z13 winglet achieved most of its theoretical potential (without twist or weight penalties).

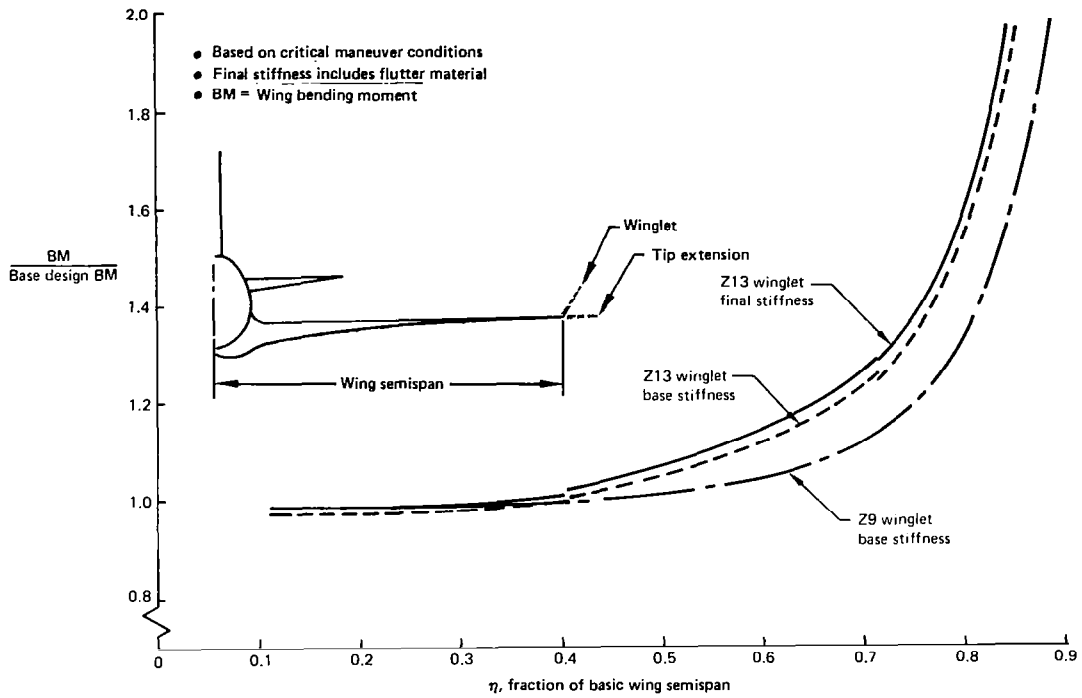

Figure 9. Effect of Winglets on Basic Wing Design Bending Moment

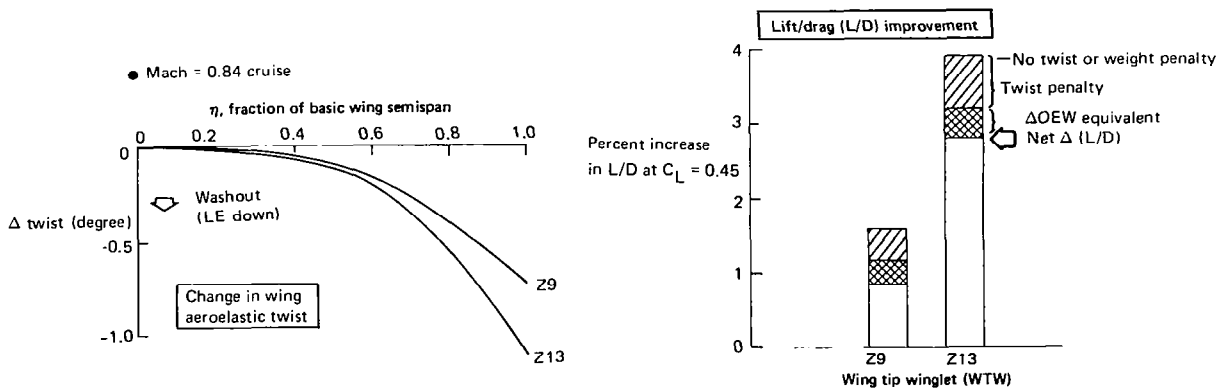

Figure 10. Wing Twist and L/D Comparison, WTW Z9 and Z13

SELECTED WINGLET (Z13) STRUCTURE AND INSTALLATION

The Z13 winglet structure (Figure 11) consists of a main box section with conventional aluminum skin stiffener and spar construction. The leading edge is fabricated from formed aluminum sheet and the trailing edge from fiberglass honeycomb panels. The front and rear spars are spliced to the wing spars with the other multiple spars terminating at an existing wing rib. Aluminum spars extend up to the winglet transition rib.

The winglet is attached to mating fittings in the wing tip by large diameter bolts. All fittings are of fail-safe design, ensuring that, in the event of one fitting failure, the remaining pair together with the adjacent structure is capable of redistributing and reacting the design load.

Modifications to wing structure and systems are required to accept the winglet. Outboard of WS 1548, the honeycomb panels must be replaced by sheet-stiffener construction, with the exception of the panel attached to the fuel tank vent scoop. An auxiliary spar is required to back up the middle attachment fitting. In addition to reinforcing the front and rear spars (for increased winglet root loads), the inboard structural box must also be revised. The basic plate and extrusion blanks are capable of accommodating the increased thicknesses. The all-aluminum construction permitted the location of the magnetic compass sensor to remain unchanged.

Changes to the control system were relatively minor, being similar to those for the wing tip extension.

It was determined design and manufacture would be considerably more complex for the winglet as compared to conventional wing tips, particularly with regard to working out the loft lines, details, and tooling in the wing/winglet junction region. Extensive engineering development and engineering flight test would be required, but FAA certification should be routine. The feasibility of retrofit would be very doubtful due to extensive changes required to the basic wing.

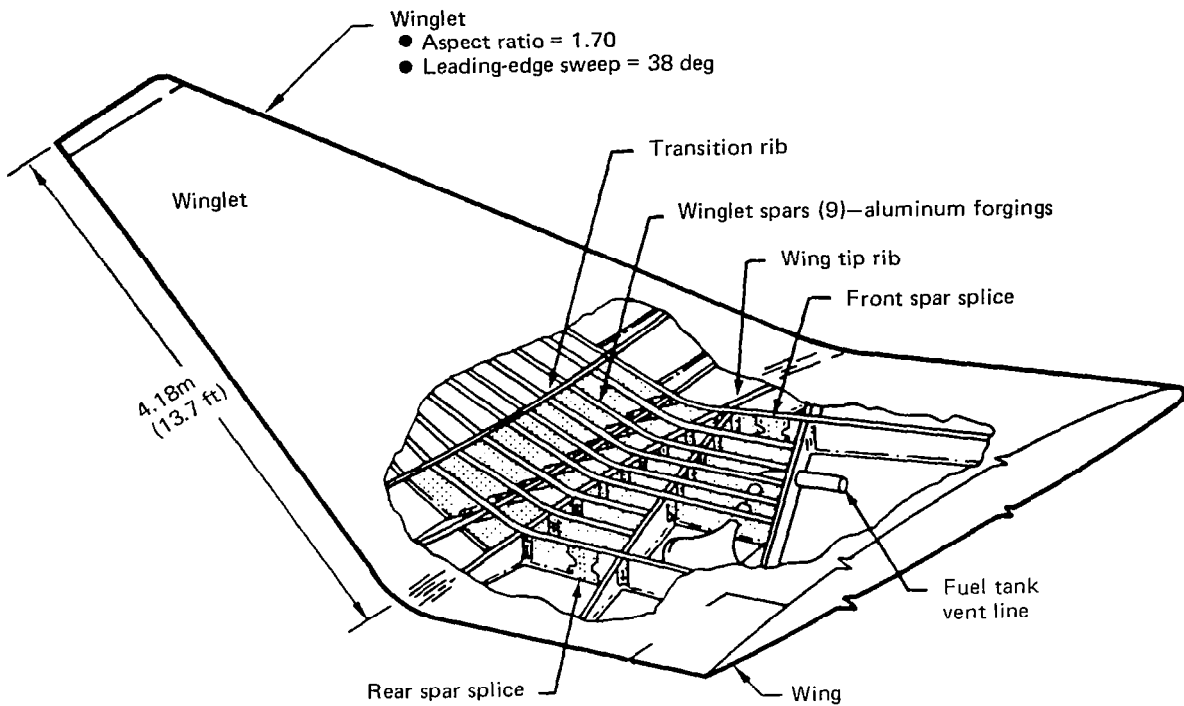

Figure 11. Attachment Concept for Z13 Winglet (Final)

WINGLETS

FLUTTER TESTING

The 747 flutter model used to define the experimental flutter characteristics with winglets is shown on Figure 12 with a rod-mounted installation in the Convair Aeronautical Laboratory low-speed wind tunnel. An existing 0.046-length scale dynamic model of the 747-200B was modified to accept a rigid set of Z9 wing tip winglets. Capability for geometric variations of cant angle and incidence angle was provided. The flow-through nacelle cowls scale inlet mass flow ratio, and spring mounts allow nacelle strut frequency variations in side bending and vertical bending. The rod mount allows freedom in pitch, yaw, and vertical translation, with low-frequency restraint in roll, side translation, and longitudinal translation.

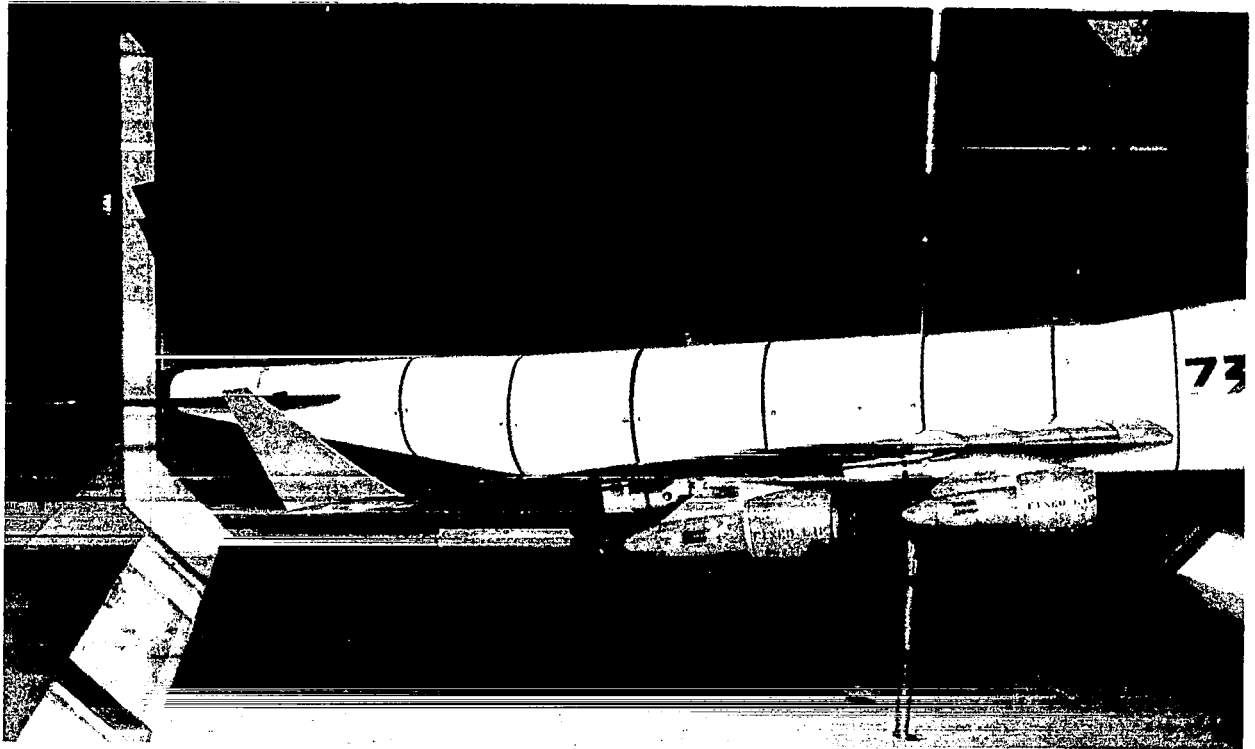

Figure 12. Model Scale–Winglet Flutter Test Setup

WING LOAD ALLEVIATION

CONCEPT

Development of the wing load alleviation (WLA) system configuration encompassed evaluation of the potential weight benefits of maneuver load control (MLC) and gust load alleviation (GLA) for the basic wing, as well as with wing tip extensions (WTE) or wing tip winglets (WTW). The WLA studies for the basic wing were restricted to consideration of the MLC and GLA functions using the outboard aileron as the primary WLA control surface. WLA functions are as follows:

- **MLC**--Reduction of the maneuver loads imposed on structure. Active outboard ailerons used to reduce maneuver loads are illustrated in Figure 13. Actuation of the ailerons shifts the lift distribution inboard which reduces wing bending moments. The resulting nose up pitching moment reduces the balancing tail load, which further reduces the wing design loads.
- **GLA**--Reduction of the gust loads imposed on structure. The final WLA control law employs wing acceleration feedback to the ailerons. Though MLC was the primary objective in the control law design, alleviation of gust-induced bending moments is provided at lower gust frequencies directly from the aileron effect on quasi-steady state lift distribution. Additional GLA is provided through elastic mode suppression (EMS) of the first wing bending mode.

Weight benefits of the MLC and GLA functions were computed independent of the control law development. Benefits of the MLC and GLA functions were isolated by first sizing the structure to accommodate maneuver loads computed with MLC active, and then resizing with baseline gust loads.

WING RESIZING

Flutter investigations were conducted to determine the stability impact due to stiffness variations resulting from an MLC designed wing without tip extensions or winglets. No added flutter material was required.

The MLC system gives reduced wing bending moments and increased wing torsions, which combine to give smaller panel skin-stringer areas. To determine the benefits of MLC, the wing box was resized to have panel margins of safety of zero and compared to a baseline wing box similarly resized.

With maneuver loads reduced by the MLC system, additional structure becomes critical for gust loads, as shown in Figure 14. The incremental sizing above maneuver loads is not large. The majority of the fatigue damage comes from the ground-air-ground cycle which is the stress excursion from maximum compression to maximum tension occurring once per flight.

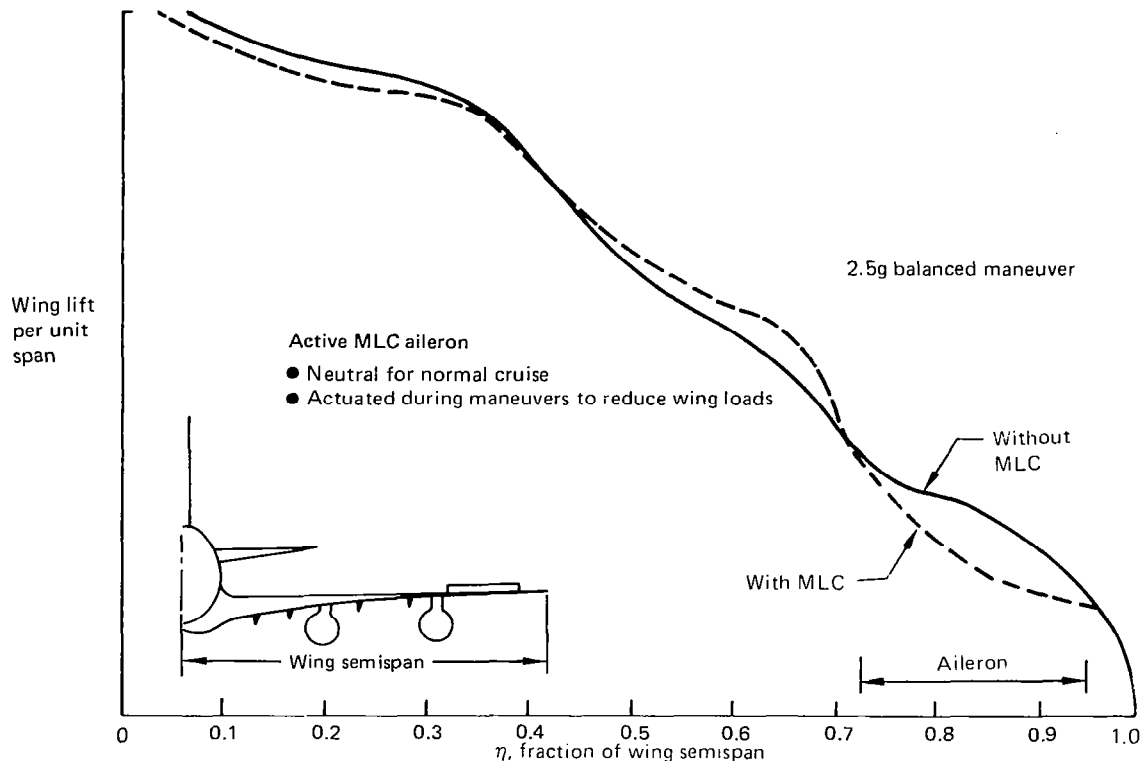

Figure 13. Maneuver Load Control Concept

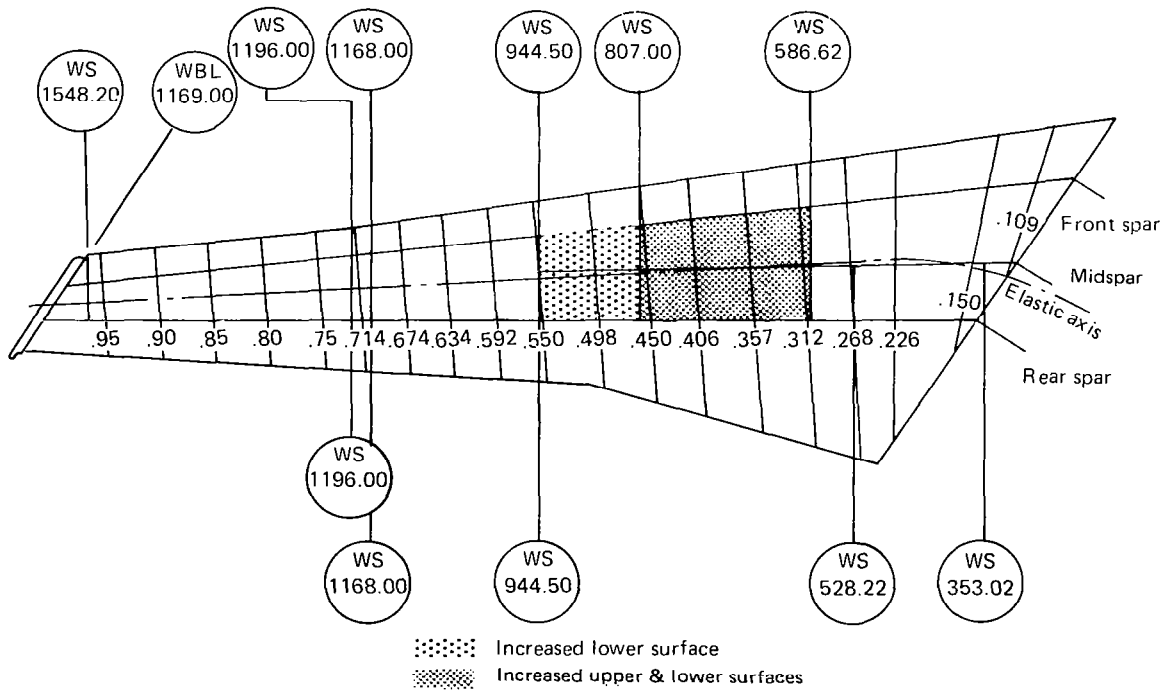

Figure 14. Effect of MLC on Wing Panel Sizing for Ultimate Gust Loads

WING LOAD ALLEVIATION

CONTROL LAW

The control law for the final WLA system incorporates first elastic mode suppression with the primary function, MLC. Two flight conditions, the gust penetration speed condition, V_B , and the structural cruising speed condition, V_C , were analyzed for elastic mode dynamics. Additional flight conditions were analyzed with quasi-static aeroelastic equations of motion to evaluate handling qualities.

A block diagram of the final control law is shown in Figure 15. From an accelerometer mounted on each wing, symmetric vertical motion is sensed by averaging the two signals. The filtered signal commands symmetric outboard aileron for elastic mode suppression as well as maneuver load control. The gains are reduced when the flaps are extended. To compensate for the aileron pitching moment, the outboard elevators are commanded proportionately. During lateral maneuvers with the flaps down, the WLA authority is reduced to give roll control priority. Engage/disengage transients are minimized by on/off circuit.

The node line for the first elastic mode, predominantly first wing bending, is on the wing. Use of center of gravity (cg) acceleration feedback to the outboard ailerons for the MLC function results in adverse coupling with this mode. A wing accelerometer to outboard aileron path augments the first elastic mode stability in a manner advantageous for load alleviation. This sensor also measures rigid body motion that is required for the MLC function. The wing accelerometer is located where motion of the first mode is appreciable, while activity of the other elastic modes is slight. The sensor was located near the outboard nacelle in a region of confluence of node lines for the second through sixth elastic modes.

The feedback signal is filtered to the outboard aileron in two parts. For MLC, the rigid body motion is sensed with a low pass filter. The break frequency is chosen to minimize the phase lag at the short-period mode frequency. This also eliminates high-frequency input signals to prevent aliasing. The feedback path provides good MLC performance but couples excessively with the elastic modes. A second filter path controls this coupling to achieve elastic mode suppression. Activity of the elastic modes is sensed with a high pass filter. The filter in series with the low pass filter forms a bandpass network centered near the frequency of the first elastic mode. The output of this filter is subtracted from the MLC signal and results in the proper augmentation of the first mode stability.

Feedback to the outboard elevators has a negligible effect on the elastic modes. The signal is scaled in proportion to the aileron MLC command to compensate for the aileron pitching moment. With only the outboard aileron loop, the WLA system significantly alters the short-period mode characteristics. However, damping and frequency are achieved with the outboard elevator loop included.

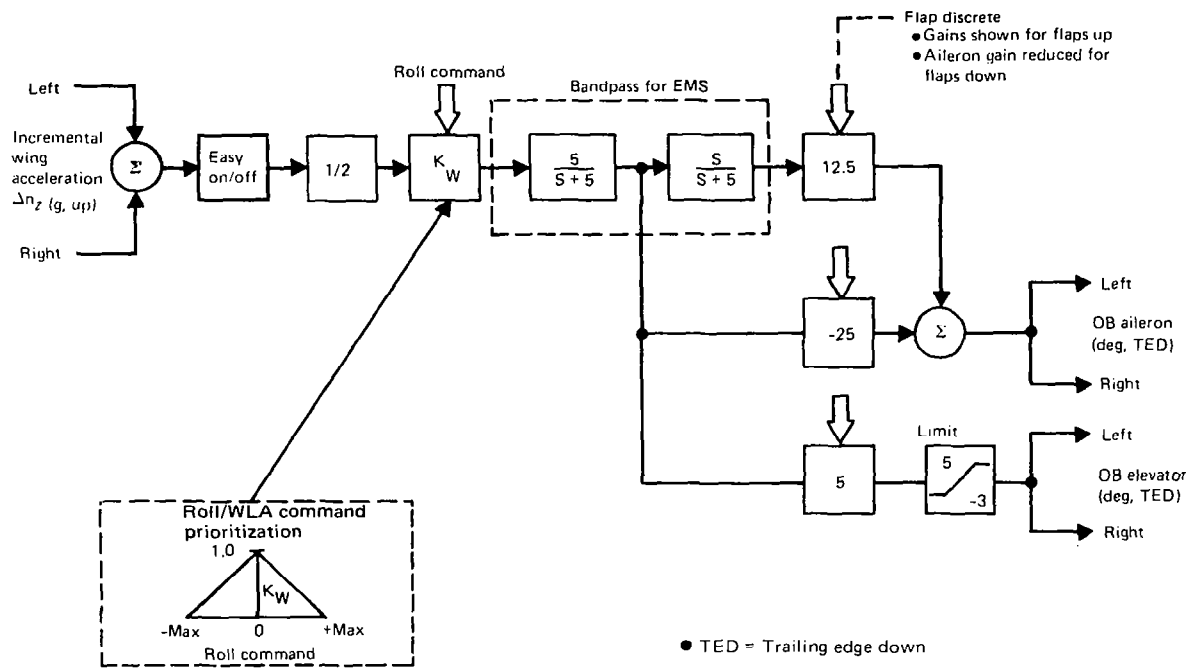

Figure 15. Final Control Law Diagram

WING LOAD ALLEVIATION

CONTROL SYSTEM

Control system mechanization and installation location are described by Figure 16. Dual, self-monitored, digital computers are the central components. Control law computation is dual redundant in each channel (dual-dual). In addition to control law computation, the system functions that reside within the computer unit are:

- Provisions for interface with the external system components.
- Inflight failure monitoring, failure status annunciation, and system shutdown.
- Automated pre-flight test that verifies operational integrity of the entire WLA system.
- Semi-automated maintenance test which led to the selection of a digital computer.

Six accelerometers are installed, three each outboard on the left and right front spars. The flap position sensors are installed in the flap extension system. One set of dual linear variable differential transformers (LVDT) installed at each aileron programmer is shared with the lateral control system. The existing outboard aileron power control unit (PCU) is replaced with a new actuator having the same stroke and force output. LVDTs are installed at each aileron programmer to provide lateral control input signals to the respective outboard aileron PCU. The aileron programmers are revised to drive the new signal transducers. A new electrohydraulic outboard elevator power control unit has the same stroke and force output as the present unit. Dual LVDTs are installed at the elevator aft quadrant.

Sensor data are cross-strapped to both computers and signal selection is performed within each. For fail-operate capability, the motion sensors (wing accelerometers) and the flap position sensors are triple redundant. The dual pilot roll input sensor is self-checking. Each actuator has fail-operate capability with two electrical and two hydraulic channels. Dual redundant servo electronics receive WLA computed commands and electrically transduced pilot/autopilot commands. In each set of servo electronics, two series sums are formed by combining the pilot/autopilot command with each of the two commands from one WLA computer.

The mode control and display panel provides flight crew interface with the WLA system. The mode control and display functions are divided between two panels, the overhead panel and the master caution panel. The overhead panel contains a master WLA system engage/disengage (ON/OFF) switch, and controls and displays necessary to perform the preflight test. All inflight detected failures are annunciated on the master caution panel to the flight crew. Failure identification is displayed on and system maintenance tests are initiated from this panel.

Wing Load Alleviation Control System

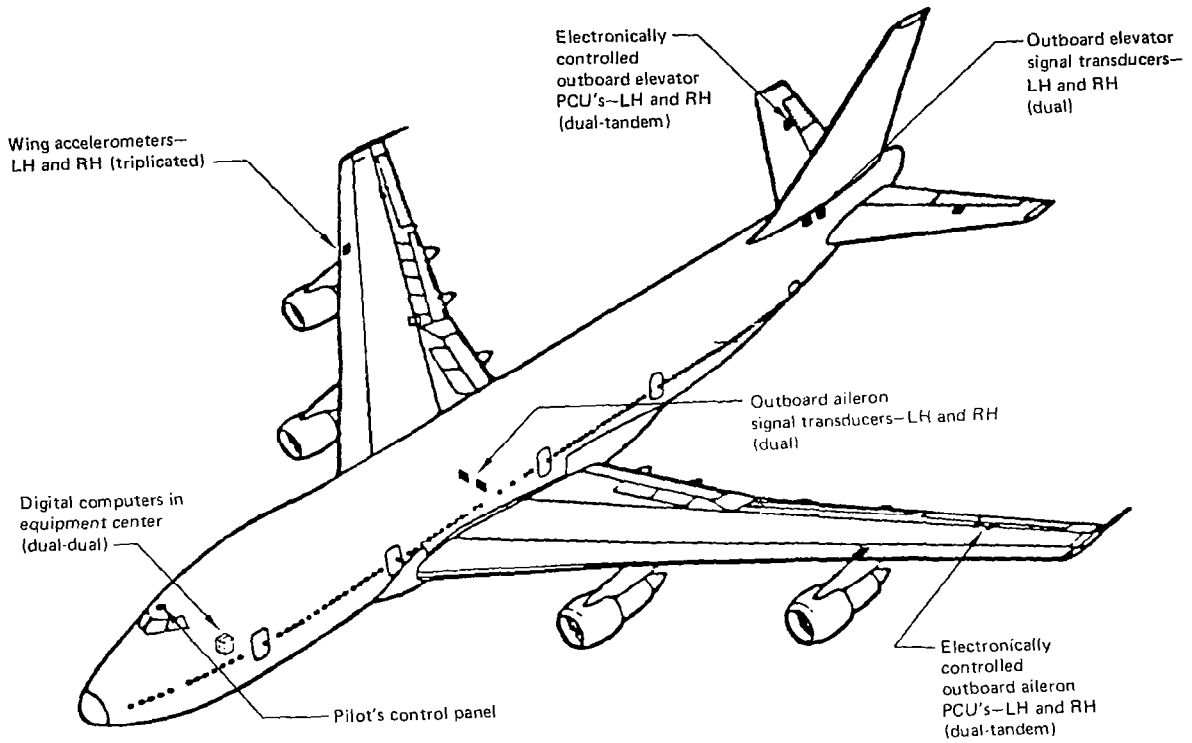

Figure 16. WLA Control System Installation

WING LOAD ALLEVIATION

WEIGHT

Estimated weight benefits of the MLC and GLA functions are indicated in Figure 17. Maneuver load alleviation allows a 771 kg (1700 lb) wing box weight reduction relative to a baseline wing. A 227 kg (500 lb) added system weight is incurred for a net expected benefit of 542 kg (1200 lbs). An additional 136 kg (300 pounds) would be available by accepting the complexity of gust load alleviation.

The wing box weight increment (fig. 17) for the "pure" MLC function corresponds to alleviation of maneuver loads only. For the wing with pure MLC, about 272 kg (600 lb) of material is required for gust design. This is indicative of the maximum potential weight benefit for an ideal GLA system. It was estimated that only about half of the potential 272 kg (600 lb) would be achievable. Comparison of the shaded areas shows approximately the same weight of fatigue material is required with or without MLC. The fatigue material required for gusts could be reduced by the GLA function.

FUEL REDUCTION

In general, the potential benefits of WLA fall in two categories:

- Wing box weight reduction relative to a wing optimized without WLA.
- Reduction of the extent of the modifications required for airplane gross weight growth for installation of a wing tip modification such as a tip extension. (Note: Application of WLA to airplane gross weight growth was not analyzed).

The potential of WLA for improving fuel efficiency is related to the first type of benefit; i.e., airplane gross weight can be increased, or a wing tip extension can be added without a WLA system at additional structural weight increment. The second type of benefit (less extensive structural modifications) is related to implementation costs rather than fuel efficiency. For 747 derivative applications, WLA offers the first type of benefit. The structural benefit analysis conducted for the basic wing with WLA showed that a net airplane operational empty weight reduction equivalent to 2% of the wing box weight could be achieved by means of MLC, and that the benefit could be increased to perhaps 2.5% by also taking credit for the GLA capability of the system.

Aeroelastic twist was increased for the wing sized with MLC. Since the jig twist of the baseline wing was not changed, the cruise twist was modified (more washout) resulting in a small L/D penalty. As indicated in Figure 18, the beneficial effect of the airplane weight reduction more than offsets the L/D penalty, providing a net fuel savings of about 0.16% attributable to MLC and 0.20% with both MLC and GLA.

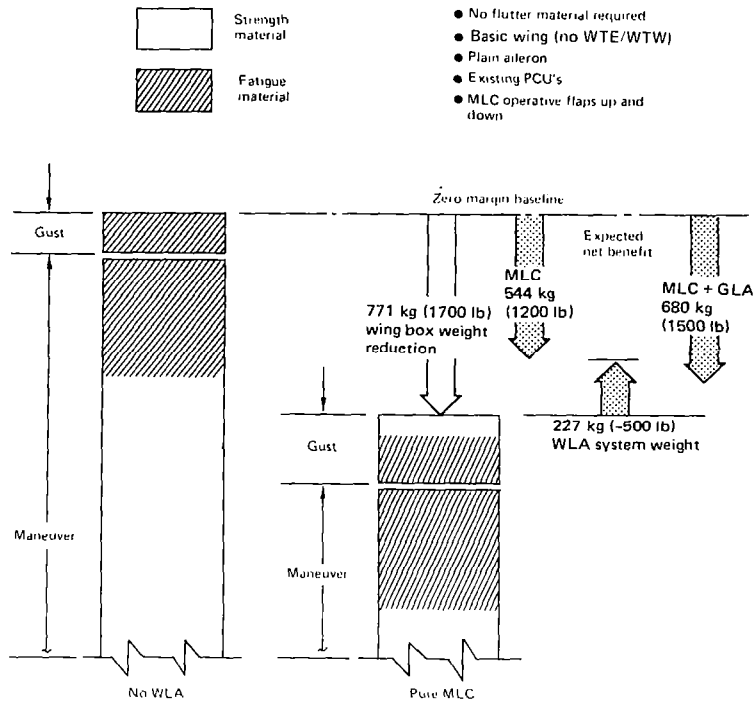

Figure 17. Wing Mass (Weights) with Maneuver Load Control (MLC)

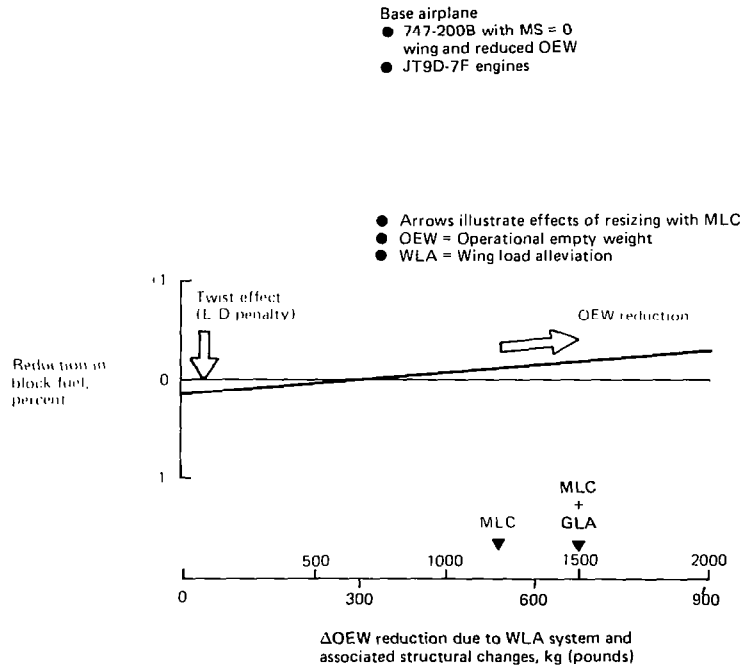

Figure 18. Fuel Saving with Maneuver Load Control (MLC) and Gust Load Alleviation (GLA)



WING STRUCTURE MODIFICATIONS

TIP EXTENSION AND WINGLET

Figure 19 shows the changes to the baseline 747B skins, spars and stringers required to accept addition of the 1.83-m (6-ft) tip extension and the winglet. Both reflect adaption to the current 747B wing, while taking advantage of existing positive margins of safety that are inherent in the basic wing. Addition of either concept to a new wing designed to zero margins would require more extensive modifications.

Both concepts would involve upper and lower skin and stringer modification in the outboard wing, with the winglet affecting more area than the tip extension. Both also require skin and stringer modification well inboard on the upper surface only for the tip extension and between the engines for the winglet. Lower surface modification is required only for the tip extension.

Front and rear spar modifications are also required for the winglet, over nearly two-thirds of the span. The tip extension affects a short portion of the outboard front spar only.

- Baseline margins absorbed
 - Shading denotes skin-gage and stringer-area changes relative to baseline wing
-  Increased upper surface skin gages and stringer areas
 Increased lower surface skin gages and stringer areas
 Increased upper and lower surface skin gages and stringer areas

1.53m (6-ft) Wing Tip Extension

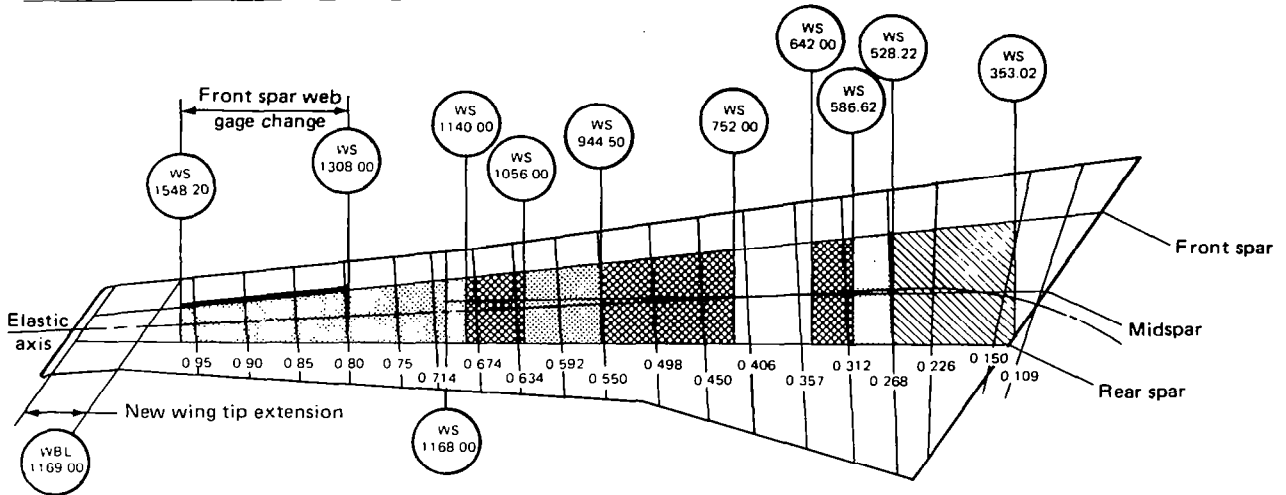

Z13 Winglet

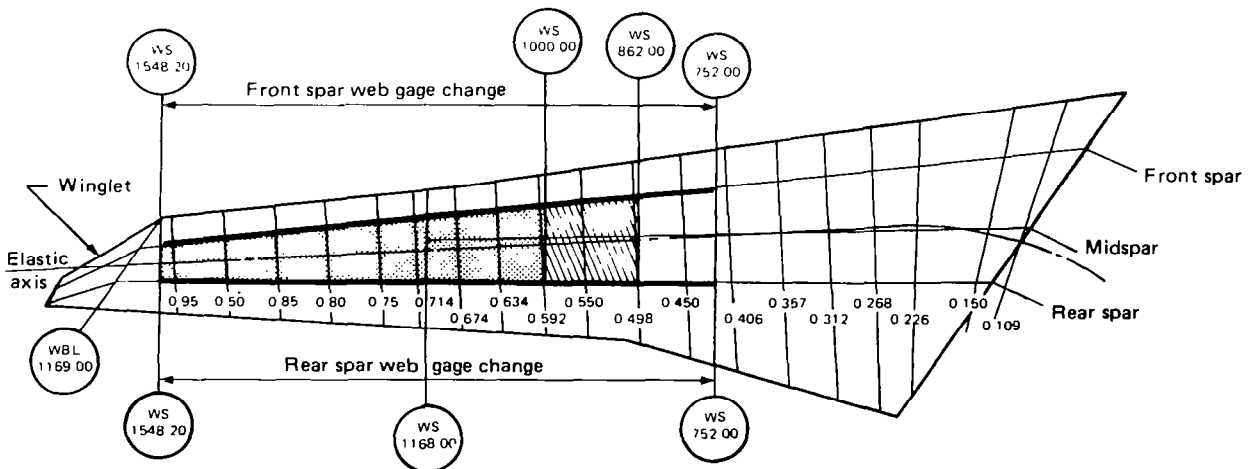

Figure 19. Wing Structural Modifications Required to Add Wing Tip Extensions and Winglets Only to Baseline Wing

WING STRUCTURE MODIFICATION

TIP EXTENSION AND WING LOAD ALLEVIATION

In contrast to Figure 19 which shows the effect on wing structure by addition of tip modifications only, Figures 20 and 21 show the effect on wing structure when the tip extension and maneuver load control are both added to the 747B baseline wing and a zero-margin baseline wing. Addition of maneuver load control significantly reduces the area of wing skins and stringer modification. However, the addition of maneuver load control does require more extensive front spar changes to accommodate the torsional effect on the wing during use of the outboard aileron as a maneuver load control device. Figure 21 shows the more extensive changes to a zero margin baseline required to handle the tip extension as compared to the baseline (Figure 20) where available margins can contribute.

Figures 19, 20, and 21 provide some insight into the question of retrofit of tip modifications for application to the active fleet. Feasibility of retrofit, using doublers to strengthen the wing box, was considered for the WTE and WTW configurations with and without MLC. It was concluded that retrofit would not be practical for any of the configurations.

Retrofit of a winglet with a 15-degree cant angle probably would be technically feasible if flutter stiffness requirements could be limited to the relatively small portion of the outboard wing where strength material was required. Even if this could be achieved (not likely), costs for retrofit would be considerably higher than for a production line installation. Tip extensions require strength "beef-up" further inboard than winglets (flutter neglected). The length of the required stringer doublers would prohibit their entry into the wing interior through fuel tank access doors. Also, disassembly of the wing would be so extensive that jig position could not be held.

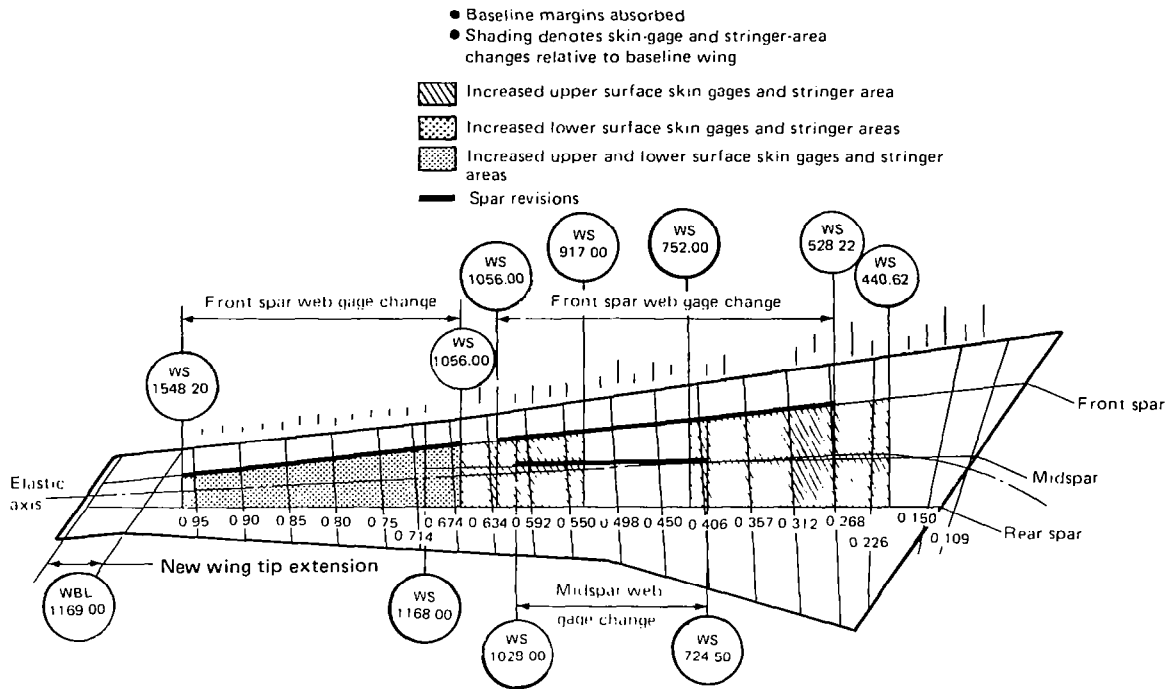

Figure 20. Wing Tip Extensions and Maneuver Load Control—Baseline Wing

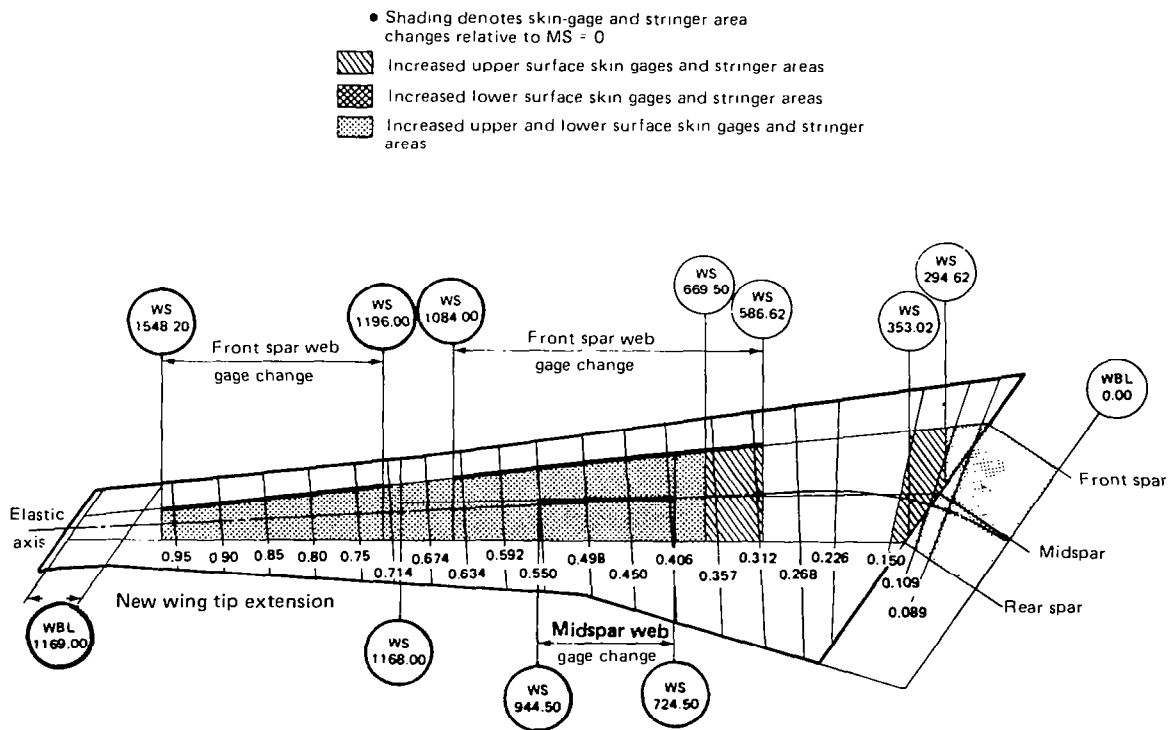

Figure 21. Wing Tip Extensions and Maneuver Load Control—Zero-Margin Baseline Wing

WING TIP EXTENSION AND WINGLETS

WEIGHT IMPACT

The increases in airplane operational empty weight (OEW) necessary for installation of wing tip modifications without wing load alleviation are compared in Figure 22 for two sets of structural resizing ground rules. The plot labeled "MS Maintained" reflects sizing of the wing structure such that the margins of safety (MS) currently inherent in the wing structure are maintained. The "MS Absorbed" plot is based on taking advantage of less structure permitted by absorbing existing margins. The data shown for the 3.66-m (12-ft) tip extension are probably optimistic since only a partial set of load conditions was considered and flutter sizing was not conducted. Weights for the 1.83-m (6-ft) tip extension and Z13 winglet were based on complete resizing analyses, including flutter sizing (no flutter material required for the tip extension).

Results show that a winglet can be added with less increase in total airplane OEW than a panel of the same length installed as a wing tip extension. The weight advantage for the winglet was found to be more pronounced when existing structural margins of safety were maintained. These data (margins maintained) give an indication of the weight increments for tip modifications on a wing having no positive margins in the baseline wing box structure. The weight increments for strength material should be reasonably representative of the corresponding increments for a zero margin wing, but the fatigue and flutter material requirements would be greater for the zero margin wing.

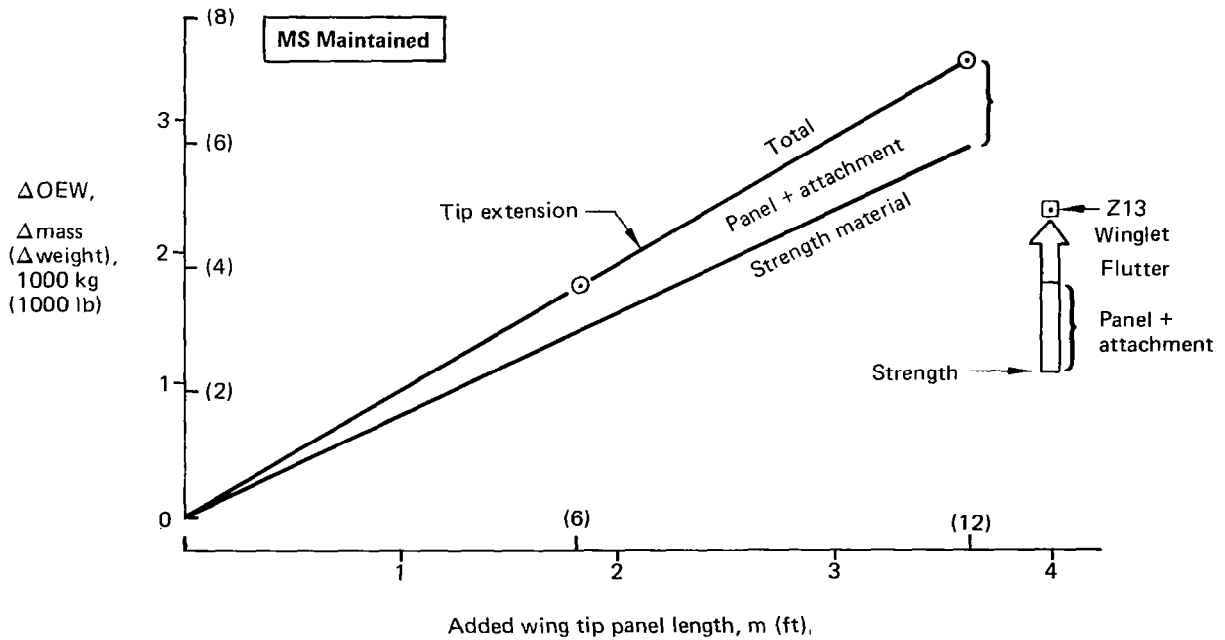
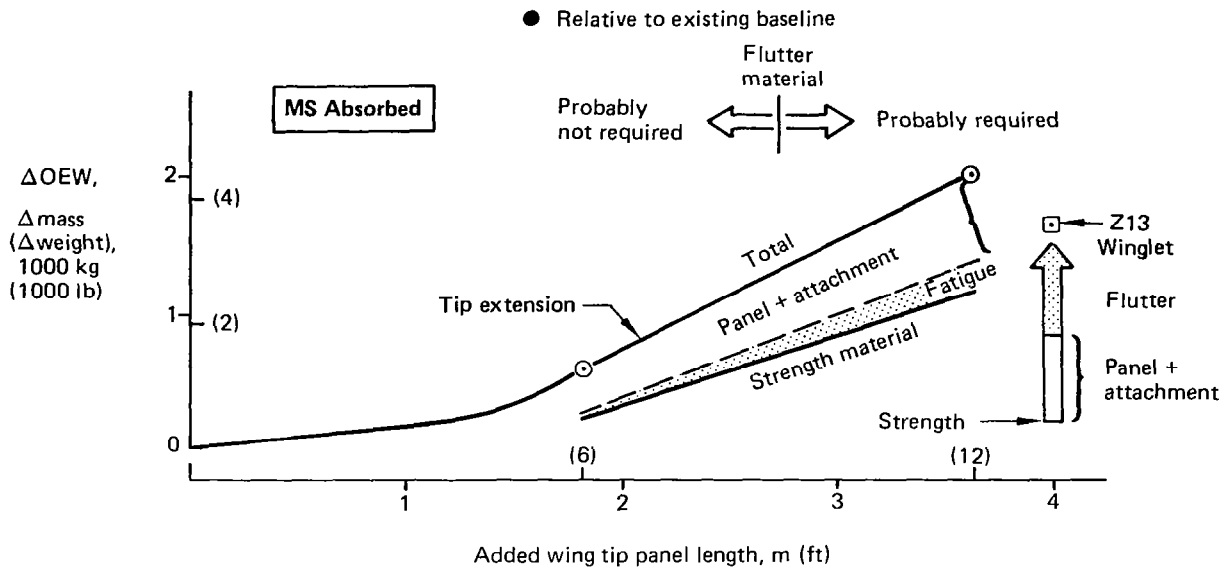

Figure 22. Weight Comparison of Wing Tip Extensions and Winglets Without WLA

FINAL EVALUATION

The final evaluation was concerned with selection of the best type of configuration, considering performance, economics, operational factors, and other data generated during the study. Performance analyses were made for configurations that included tip modifications, with and without maneuver load alleviation. In the economic comparisons, it was assumed that the fuel savings data for all configurations applied without maneuver load control, and that additional fuel savings of about 0.2% could be attained by combining wing load alleviation with any of the wing tips in line with study results of the basic wing that had been conducted specifically to isolate wing load alleviation benefits.

PERFORMANCE

Figure 23 compares cruise $(L/D)_{MAX}$ ratio for the 1.83-m (6-ft) and 2.74-m (9-ft) tip extensions and the Z13 winglet. The effect of adding MLC to the 1.83-m (6-ft) tip extension configuration was insignificant. Again, the L/D equivalent of the increased operational empty weight was obtained using trade factors which are valid for non-takeoff gross weight limited missions, e.g., 5556 km (3000 nmi). Net $(L/D)_{MAX}$ improvement was 2.5% for the Z13 winglet compared with 1.9% for the 2.74-m (9-ft) tip extension plus MLC.

Results of a potential flow analysis of a 747-200 with a 2.74-m (9-ft) WTE indicate that wing tip stalling will likely occur near the critical one-engine-inoperative climb-out condition (V_2) in the takeoff configuration. Stalling is not predicted at the approach condition with flap detent 30. Low-speed wind tunnel testing is necessary to determine what additional leading-edge flap span would be required to eliminate problems due to premature stall. However, the theoretical analysis indicates that an extension of the leading-edge flap to WBL 1234 (about 50% of the span extension) should be adequate to protect the extended wing up to $C_{L_{MAX}}$.

Evaluation indicated a potential reduction in approach speed with flaps at detent 30, of less than 0.5 knot with winglets installed on the 747-200. Similar results could be anticipated with winglet Z13, provided there are no separation or buffet problems. Low-speed wind tunnel tests would be required to evaluate flow separation and buffet onset points.

Figure 24 shows the potential fuel reduction offered by four of the potential combinations of tip modifications with and without maneuver load alleviation. Mission performance was based on constant Mach 0.84 step cruise at altitudes of 9 500, 10 670, and 11 890 m (31 000, 35 000, and 39 000 ft). This allows the airplane with tip modifications to fly at higher optimum altitude to take advantage of improved aerodynamics. All candidates show consistently increasing potential as mission range is increased. The winglet and 2.74-m (9-ft) tip extension stand out as the prime candidates when fuel use is the only consideration. Addition of maneuver load control would provide a small additional improvement.

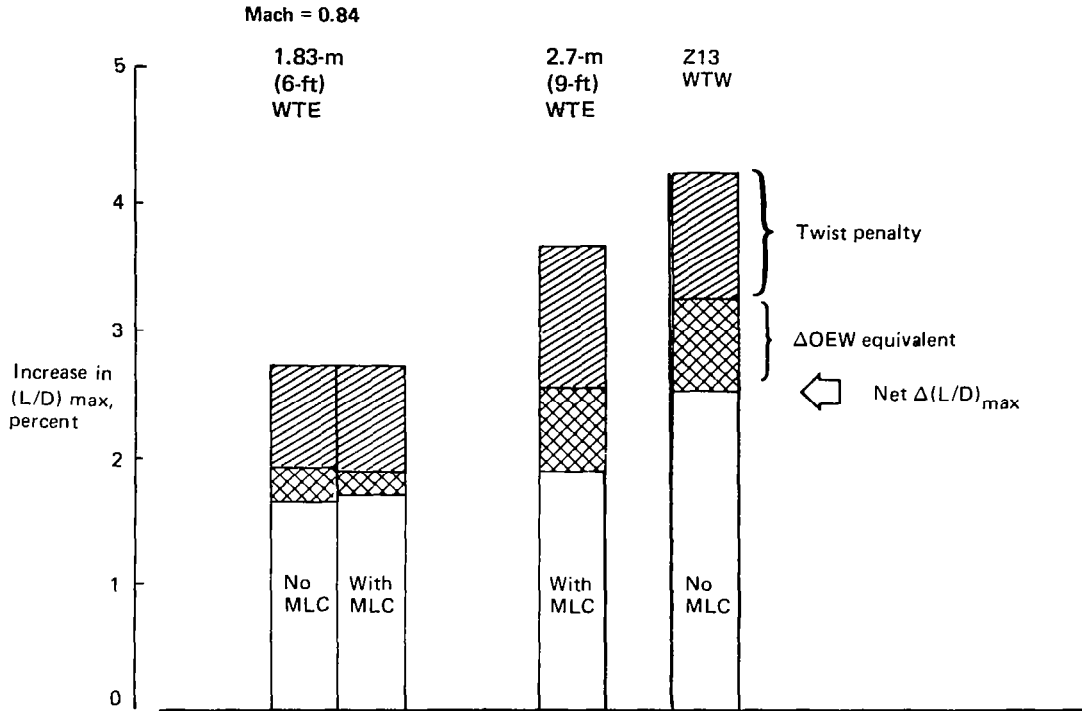

Figure 23. Lift-to-Drag Comparison Wing Tip Extensions Versus Winglets

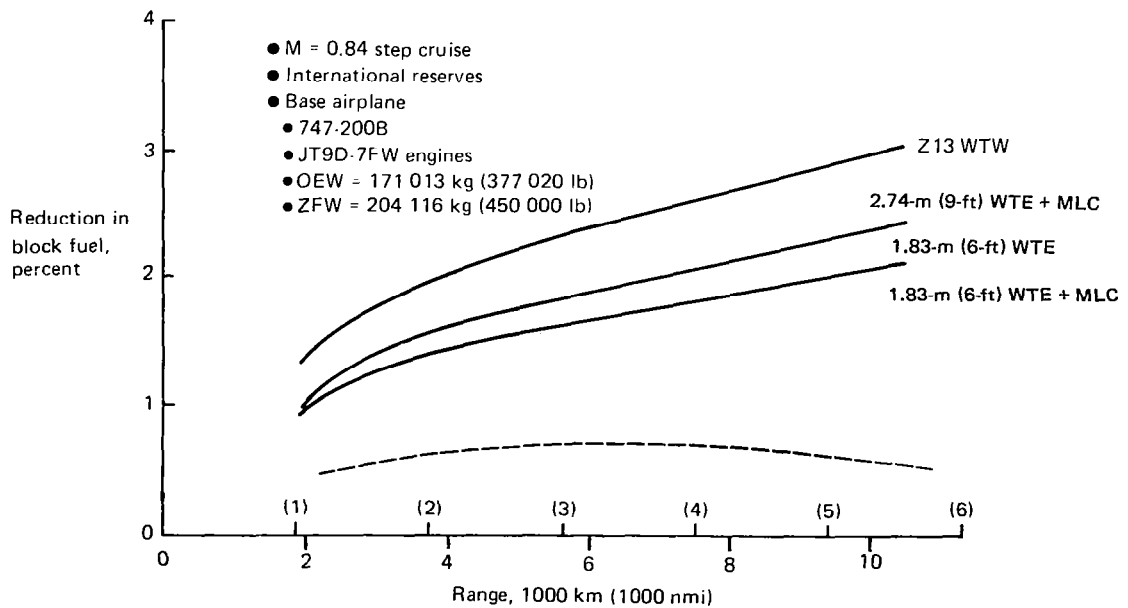

Figure 24. Percent Block Fuel Savings

FINAL EVALUATION

FUEL USE ECONOMICS

Figures 25 and 26 show the operating cost savings per year as a function of mission range and fuel price that would accrue to operating airlines when the 1.83-m (6-ft) tip extension or the winglet is included in the design. Again, all the curves would raise slightly if maneuver load control were included. The winglet again appears as the best candidate at all fuel prices. Results of evaluation analysis to this point provided the economic benefits data that could be balanced against the costs associated with the various concepts.

For 747 passenger models, there is no payload penalty or benefits provided by any of the concepts up to about 8334-km (4500-nmi) range due to airplane volume limits; i.e., with a full passenger payload, the cargo compartments can be filled with average density cargo before weight limits become constraints. However, payload increases are available for the tip extensions and winglets at very long ranges.

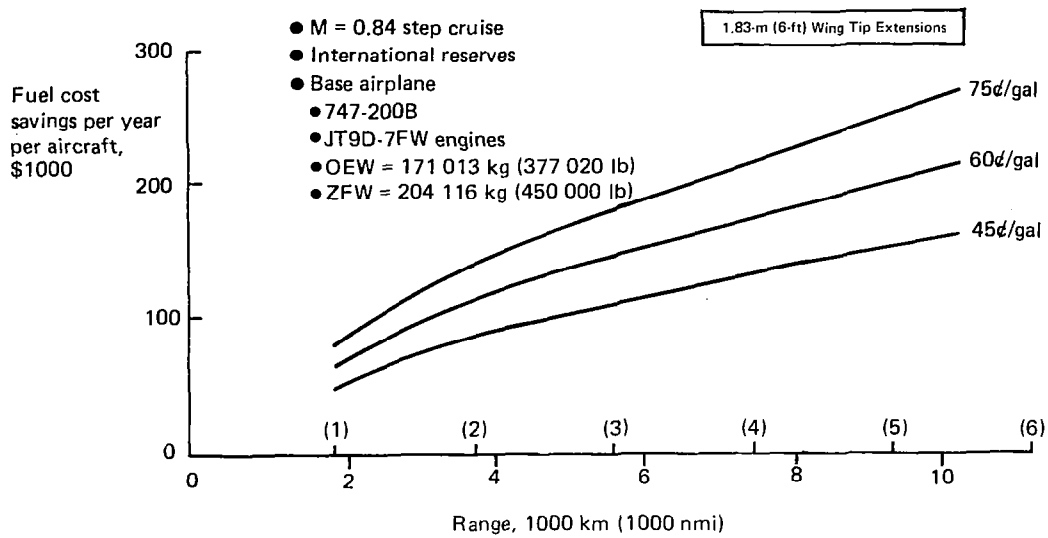

Figure 25. Fuel Cost Savings Per Year—Wing Tip Extensions

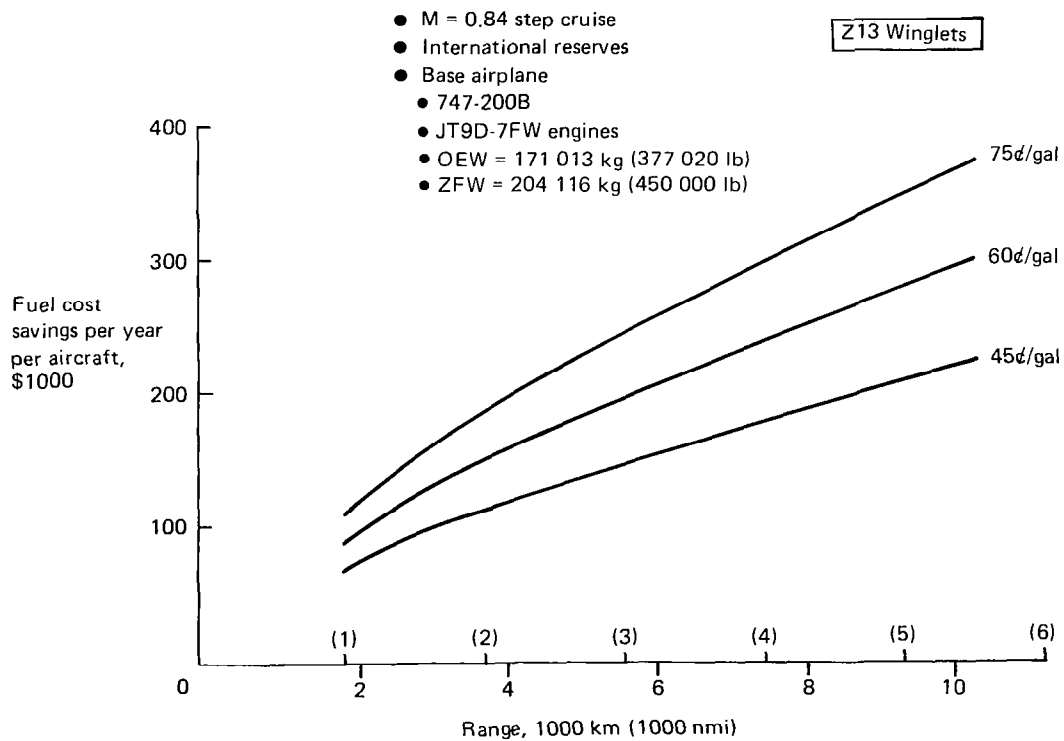

Figure 26. Fuel Cost Savings Per Year—Winglets

FINAL EVALUATION

TIP EXTENSIONS - WINGLETS PRODUCIBILITY

The nonrecurring engineering, ground test, and certification flight test resource requirements for all of the concepts were estimated with reference to historical data. Tooling costs for the WTEs were estimated from experience and extrapolated to the winglet, considering the increased complexity.

The increased complexity of the winglet relative to the 1.83-m (6-ft) tip extension is illustrated in Figure 27. The figure shows the winglet projected in the same plane as the wing tip extension. Spars and ribs are indicated, but most of the stringers have been omitted for clarity. For purposes of comparing complexity, the winglet installation can be considered to consist of three parts. First, the existing wing tip must be modified. This is somewhat more complex for the winglet. Second, there is a transition section for the winglet containing nine aluminum forgings and the highly contoured wing-winglet juncture. This section does not exist for a tip extension. Third, there is the winglet panel with construction similar to the tip extension. This panel, about twice the length of the 1.83-m (6-ft) tip extension but with a smaller chord, has more parts than the tip extension. Tooling is obviously more expensive for the winglet. Recurring manufacturing costs were estimated to be about three times greater due to the larger size and more complex construction and contours.

Cost evaluation was also made of the structural and equipment implications of wing modification and electro/mechanical equipment required to incorporate maneuver load control into the basic design. This included contact with equipment suppliers to establish credible cost inputs to the economic evaluation.

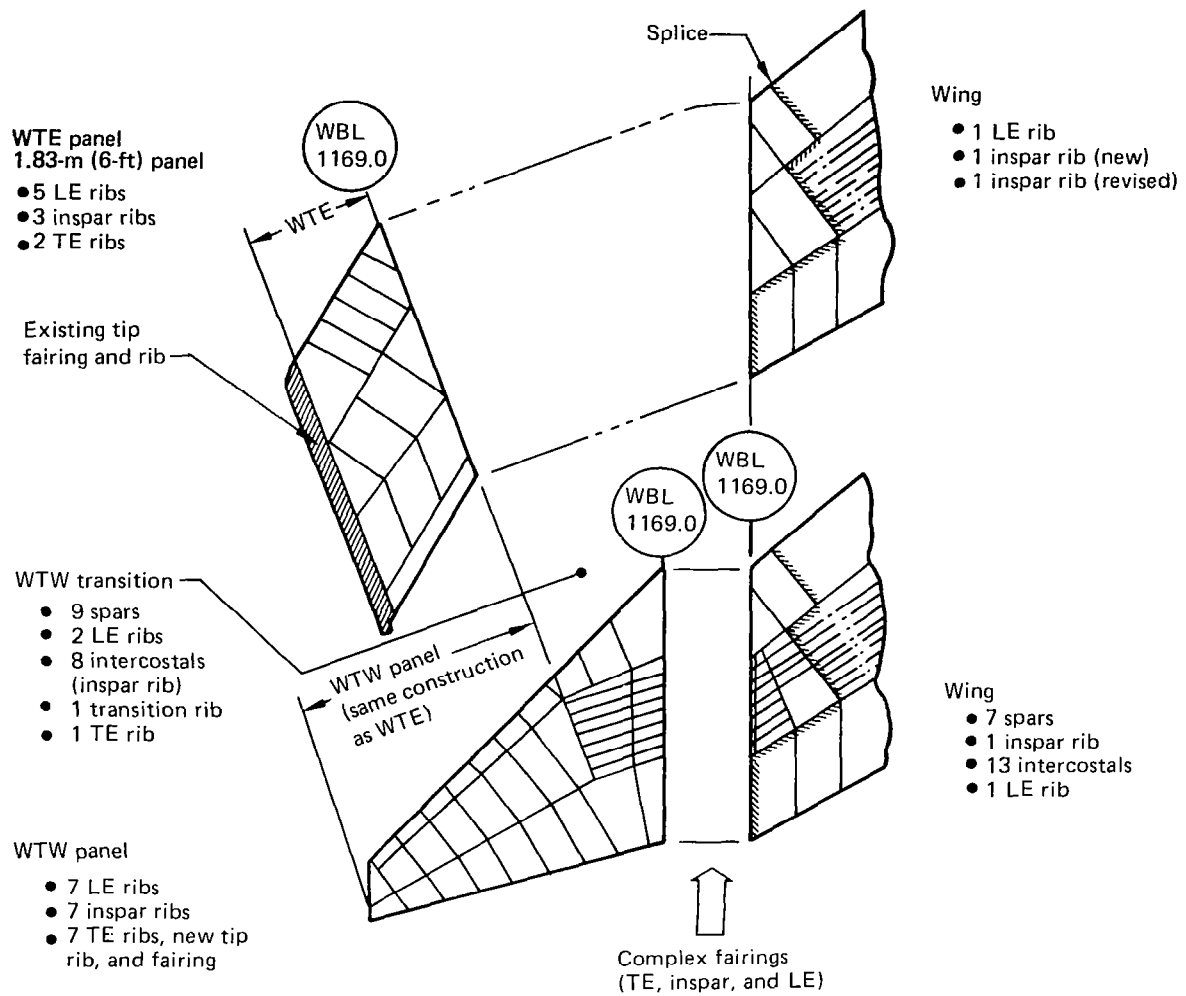

Figure 27. Structural Complexity Comparison of WTE/WTW

FINAL EVALUATION

RETURN ON INVESTMENT (ROI) COMPARISONS

The concepts studied in the program are intended to improve fuel efficiency on existing routes, as contrasted with concepts intended to provide a new capability or open up new routes. The potential return on the customer airline's investment (ROI) is usually considered in deciding between alternate configurations of the type considered in this study. The ROI calculation takes into account the costs of a concept, as well as the performance benefits. The 15% ROI shown in Figure 20 is the minimum acceptable return required before an airline would consider undertaking an investment of the type discussed in this study. The major cost to the airline associated with any of the concepts would be the purchase price of the equipment. Estimated prices are shown parametrically as a function of market base for the 747 average stage length of 3704-km (2000-nmi) range.

An important ground rule used in estimating production costs for this study was that research, development, and engineering flight test program costs were excluded. These costs were excluded to permit a comparison of actual production program costs, assuming an equal technical development status for all of the concepts.

The economic analysis used incremental ROI analysis. Each configuration is analyzed as though each concept were applied to the baseline 747 as an option offered to a customer, with customer evaluation of each option without regard for the desirability of the basic airplane. Results of the cost analysis are shown in Figure 28, which indicate that a wing tip extension without leading-edge flaps and without wing load alleviation is the only study configuration that could be expected to provide an ROI in excess of the acceptable return at the then current fuel price. Increased fuel prices shown by Figure 30 show increased fuel price will alter the ROI comparisons only to the extent that fuel prices escalate relative to the overall inflation rate.

Based on the assumption that all parameters affecting ROI, except fuel price, remain constant, the ROI offered by the winglet improves as the price of fuel is increased. The winglet would yield an acceptable return at around \$1.00/gal fuel cost, assuming that the price of the winglet also did not escalate. That is, undoubtedly, an unrealistic assumption as increased energy costs invariably affect other parameters in the ROI equation, particularly production costs.

Cash flows were calculated using constant (1978) dollars. The costs for airport gate and maintenance facility modifications were not included. It was assumed that operational maintenance costs would be unchanged by the wing tip modification. Though negligible, added flight control system maintenance costs (\$0.29 per flight hour increase) was included. Other pertinent ground rules were:

- 15 years useful life
- 48% tax rate
- Depreciation based on sum of years digits, 10 years to 10% residual value
- 10% investment tax credit taken over 3 years
- 3704-km (2000-nmi) range
- 850 trips per year utilization

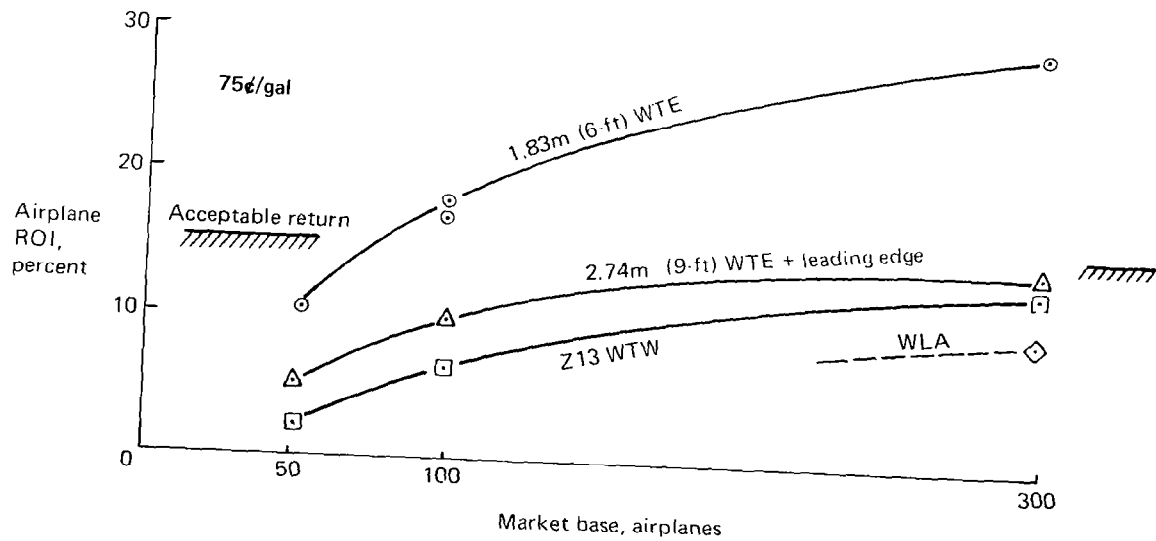
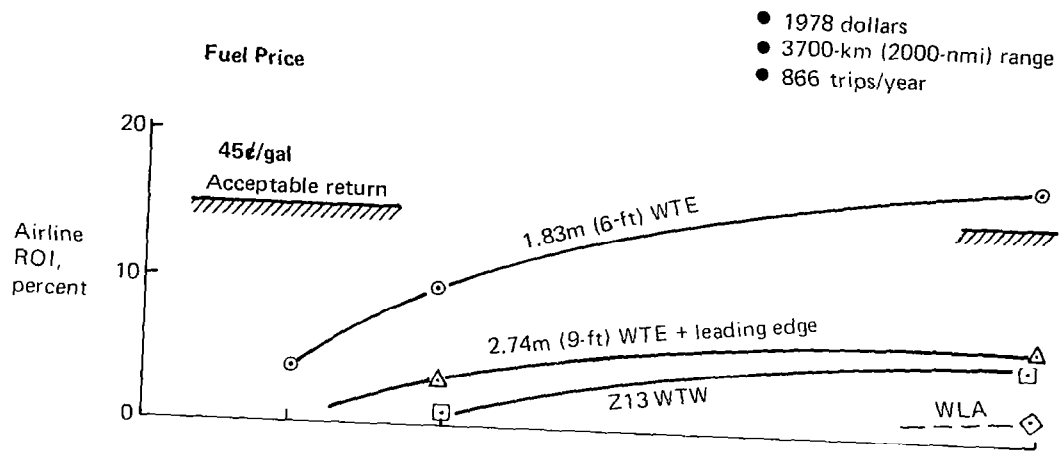

Figure 28. After Tax Return on Modification Investment

FINAL EVALUATION

ACQUISITION PRICE PAYBACK

The trades between initial purchase price and fuel cost savings for the 1.83-m (6-ft) tip extension and the winglet are illustrated in Figures 29 and 30. The purchase price appears as an initial cash outlay. The slope of the lines reflect the annual fuel cost savings only; i.e., taxes, depreciation, etc., are not included in these illustrations. The points where the curves pass through zero give an indication of the relative time required to recover the initial investment for the various concepts. Comparison of the figures indicates that the winglet becomes more competitive at longer ranges and escalated fuel prices. The effect of varying the purchase price can be visualized by parallel displacement of the curve(s) of interest.

In spite of the respectable fuel savings potential offered by the various concepts, their effect on airline economics become dominant. In this respect, the following general conclusions were drawn relative to the economics analysis results shown on Figures 29 and 30.

- Current fuel price would not support adoption of any of the concepts based on the normal airline desire to obtain payback within 1-2 years.
- The 1.83-m (6-ft) tip extension offers the best potential showing a 4-year payback at 45¢/gal fuel at the 7400-km (4000-nmi) range (a very limited market), 5 years at 60¢/gal and 3700-km (2000-nmi) range (realistic market) and 3 years at 60¢/gal and the 7400-km (4000-nmi) range (limited market).
- Production costs of the winglet would have to be reduced over 60% to make it competitive with the 1.83-m (6-ft) extension.

The overall conclusion drawn from these economic comparisons was that it is unlikely that winglet price can be reduced enough or that fuel costs will escalate enough to warrant near-term development of the winglet for commercial 747 implementation. The tip extension offers the best potential and could be included as part of the natural growth of the 747 airplane.

The fuel savings attributable to WLA were insufficient to provide a positive ROI for the system; therefore, ROI curves are not shown for wing tip modifications combined with WLA.

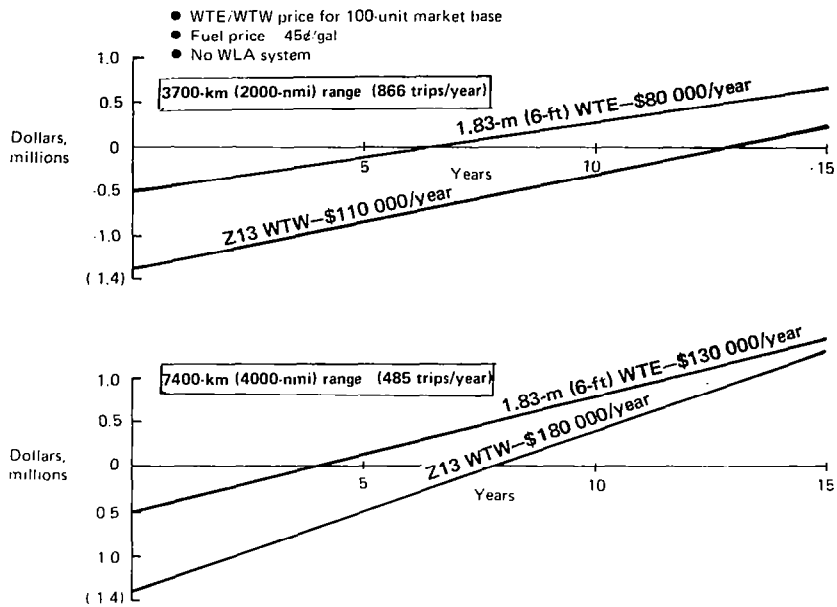

Figure 29. WTE/WTW Price/Payback Comparison for Current Fuel Price

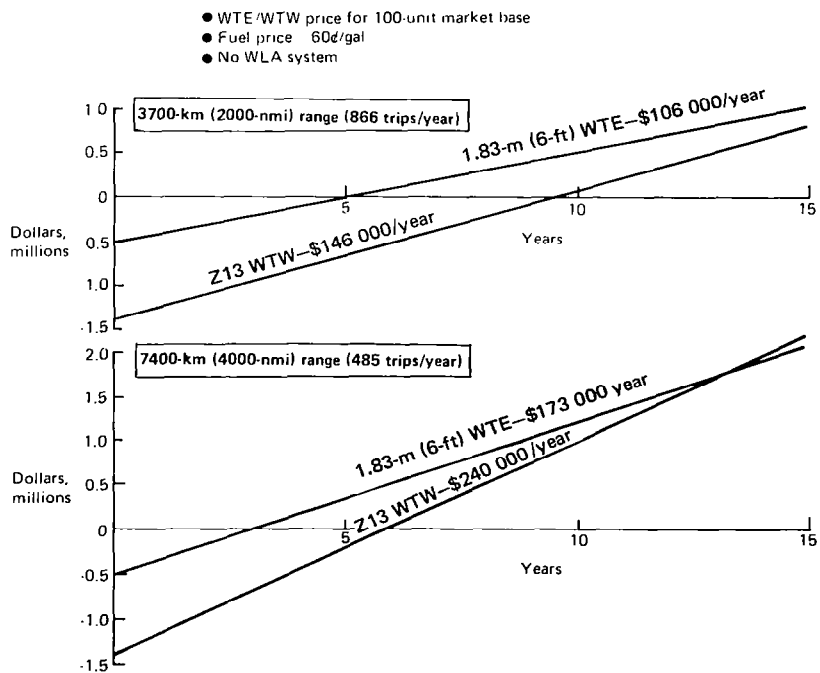

Figure 30. WTE/WTW Price/Payback Comparison for Escalated Fuel Price

FINAL EVALUATION

OPERATIONAL CONCERNS

The effect on airline operations is one of the prime customer concerns they thoroughly consider before adopting new concepts. In spite of attractive experimental airplane and fuel reduction costs offered by a concept, it can present airline facility or personnel costs that would make adoption prohibitive. Prime considerations include:

Reliability and Maintenance Cost--The wing load alleviation system defined during the study is mechanized as a simple system with high reliability and with only a small increment to the total airplane maintenance cost. The mean time between system failure is predicted to be better than 75 000 hours and the reliability approaches that of a dual yaw damper system. Maintenance of the WLA system is facilitated by the built-in test, which identifies a failed component to the line replaceable unit (LRU) level.

The maintenance cost of the wing load alleviation system was assessed at \$0.29 per flight hour. On a component-by-component basis, this is similar to the cost for a dual yaw damper system. Dispatch with only one channel operational is an objective for all except very long-range routes. Thus, no delay or cancellation costs were included in the maintenance cost estimates.

Effect of System Failures--The failures analyzed for the wing load alleviation system included both passive and hardover failures of the aileron control surface with the wing resized to zero margin of safety with MLC.

Inflight Failures--With the surface failed in the neutral position (passive failure) the structure was analyzed for the design limit load envelope using a safety factor of 1.0. In addition, the structure was estimated to be failsafe for a passive failure of the system using limit loads for a normal operating condition and a failsafe factor of 1.0. Finally, limit loads were computed for a hardover failure of the aileron for a normal operating condition. The bending moment results from this condition for a safety factor of 1.0 were shown to be less than the design envelope.

Placards For System Off Dispatch--The design bending moment envelope for the WLA system inactive was developed. A takeoff gross mass (weight) reduction of 22 680 kg (50 000 lb) resulted. The wing design bending moments for this configuration exceed the design envelope for the basic configuration with active wing load alleviation, but the torsions are reduced. A penalty of 91 kg (200 lb) was included to provide required wing strength for this configuration.

Gate and Hangar Access--A brief survey of the impact of the tip modifications on airport ground operations and maintenance facilities was conducted by United Airlines (UA) as a subcontract study item. Some of the concerns expressed by UA are outlined in Figure 31. In general, it was concluded that these concerns would not be a factor in choosing between tip extensions and winglets for the 747, provided the winglet did not extend below the wing tip. Winglets below the wing tip could interfere with parking and flight line maintenance/refuelling operations. Gate spacing and parking ramp area provisions at some airports would be affected about equally by the 1.83-m (6-ft) tip extension or the winglet. Costs for modifying maintenance facilities (docks, etc.) were estimated and found to be relatively minor. A more detailed examination involving cost/benefit trades for the selected configuration was recommended by UA prior to committing either concept to production.

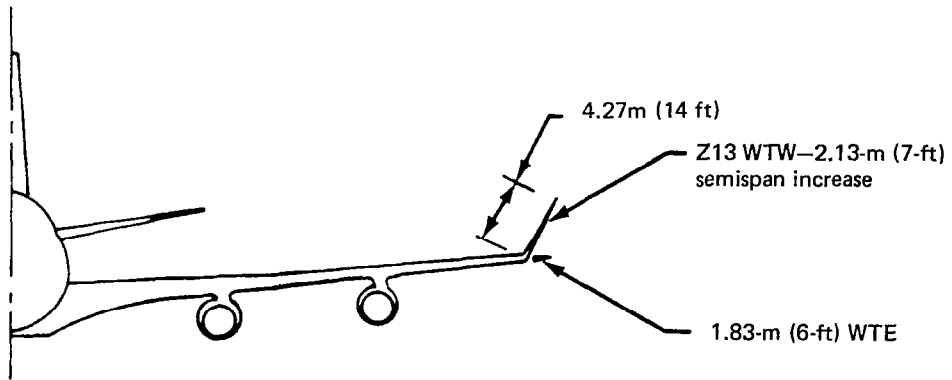

- UA study identified potential problem areas:
 - Terminal area
 - Taxi lanes
 - Aprons
 - Parking gate clearances
 - Maintenance facilities—some hangar and dock modifications required (relatively minor)
 - Not a factor in choosing between 1.83-m (6-ft) WTE versus Z13 WTW
- } Reduced clearances and loss of gates at some airports

Figure 31. Increased Semispan Operational Concerns

REFERENCE

1. Selected Advanced Aerodynamics and Active Controls Technology Concepts Development on a Derivative B-747 Aircraft—Final Report. NASA CR-3164, 1980.

1. Report No. NASA CR-3295		2. Government Accession No.		3. Recipient's Catalog No.	
4. Title and Subtitle SELECTED ADVANCED AERODYNAMICS AND ACTIVE CONTROLS TECHNOLOGY CONCEPTS DEVELOPMENT ON A DERIVATIVE B-747 AIRCRAFT - Summary Report				5. Report Date June 1980	
				6. Performing Organization Code	
7. Author(s) Staff of Boeing Commercial Airplane Company (747 Product Development)				8. Performing Organization Report No.	
				10. Work Unit No.	
9. Performing Organization Name and Address The Boeing Commercial Airplane Company P.O. Box 3707 Seattle, Washington 98124				11. Contract or Grant No. NAS1-14741	
				13. Type of Report and Period Covered Contractor Report May 1977-May 1979	
12. Sponsoring Agency Name and Address National Aeronautics and Space Administration Washington, D C 20546				14. Sponsoring Agency Code	
15. Supplementary Notes Langley Technical Monitor: David B. Middleton Summary Report for NASA CR-3164					
16. Abstract A summary description of analytical design and wind tunnel test evaluations covering the feasibility of applying wing tip extensions, winglets, and active control wing load alleviation to the Model 747 is provided. Included are evaluation results of aerodynamic improvement offered by wing tip extension and winglet individually and the combined aerodynamic and weight improvements when wing load alleviation is combined with the tip extension or the winglet. Results are presented in the form of incremental effects on weight, mission range, fuel usage, cost, and airline operating economics.					
17. Key Words (Suggested by Author(s)) Wing tip extensions Winglets Active controls Wing load alleviation			18. Distribution Statement FEDD distribution Subject Category 05		
19. Security Classif. (of this report) Unclassified		20. Security Classif. (of this page) Unclassified		21. No. of Pages 50	22. Price