

ANALYTICAL CALCULATION OF A SINGLE JET
IN
CROSS-FLOW AND COMPARISON WITH EXPERIMENT

R. W. Claus
NASA Lewis Research Center
Cleveland, Ohio 44135

INTRODUCTION

With the increasing costs of combustor development testing, a great deal of interest has focused on the use of numerical models to screen design changes or develop new combustor concepts. This type of combustor based design process now appears to be feasible through the use of 3D combustor performance models such as those reported in refs. 1 and 2. Ultimately, actual hardware testing may, someday, be used only for final design verification.

A number of major restrictions must be overcome before this type of design methodology can be adopted. First, the proper physics must be incorporated into the differential equations used in the combustor model. Second, numerical methods must accurately solve these differential equations. Finally, the accuracy of the resulting code must be assessed against fundamental data and improvements made to the code to alleviate identified deficiencies.

Currently available 3D combustor performance models have yet to be thoroughly assessed. A few comparisons have been made against actual combustor hardware, ref. 3, but these have not been conclusive. A more logical first step is to examine the extent to which three-dimensional hydrodynamic processes can be calculated. One flow field of this type for which a great deal of experimental data exists is jets in cross-flow.

Jets in cross-flow are practically relevant to the gas turbine combustor designer. Cooling air jets (dilution jets) are used to control the hot gas temperature profile entering the turbine. They are also used to set up aerodynamic patterns within the combustor which promote mixing and control local burning zone stoichiometry. As a result the jet penetration and mixing characteristics of jets in cross-flow are of primary concern in the combustor design process.

There have been a number of previous calculations of jets in cross-flow, refs. 4, 5, and 6, however, these studies have been limited by two main factors. First, although a great deal of experimental data exists, rarely have important parameters such as the turbulence field, inlet velocity profiles and jet mixing characteristics been fully measured. This limits the flow field quantities one can compare and imposes the need to assume inlet boundary conditions of the calculation. The recent measurements of reference 7 greatly reduce this problem. Second, core storage and economy requirements have limited previous calculations to coarse grid systems. This

results in some numerical error being present in the computed solution, which can possibly call into question any conclusions drawn from these studies.

The present report expands on this previous work by employing a series of progressively finer grid systems to calculate the single jet in cross-flow experimentally measured in ref. 7. These experimental measurements provide a fairly complete collection of velocities, turbulence intensities, and jet concentration profiles with measurements of the inlet field. The use of a series of progressively finer grid systems allows a differentiation between numerical errors and the hydrodynamic modeling assumptions embodied in the 3D combustor code of ref. 1. The results of this comparison will provide additional insight into the deficiencies of the turbulence model and the code numerics.

CONCLUSIONS

Employing a 3D finite-difference model to analyze the jet flow field of ref. 7, the following conclusions were determined.

1. With a reasonable number of grid points (approximately 40 x 30 x 20) calculated jet penetration and concentration profiles agreed well with experimental measurements.
2. For the cross-stream vortex, the agreement between experimental and calculated results become less qualitative as additional grid points were added - indicating a deficiency of the isotropic turbulence model.
3. The calculated results of the finest grid examined (90 x 40 x 22) were grid dependent. An improved numerical scheme is required to remove the effects of numerical diffusion for the flow geometry examined.

REFERENCES

1. Mongia, H. C.; Reynolds, R. S.: Combustor Design Criteria Validation, Volume III - User's Manual. USARTL-TR-78-55C. Feb. 1979.
2. Design and Development of Gas Turbine Combustors - Basic Computing Section. Volume III User's Manual. NREC Report No. 1420-3, 1981.
3. Serag-Eldin, M. A. S.; Spaulding, D. B.: Computation of Three Dimensional Gas Turbine Combustion Chamber Flows. ASME Trans. 1978.
4. Patankar, S. V.; Basu, D. K.; Aplay, S. A.: Prediction of Three Dimensional Velocity Field of a Deflected Turbulent Jet. Journal of Fluids Engr., Volume 99, 1977.
5. Jones, W. P.; McGuirk, J. J.: Computation of a Round Turbulent Jet Discharging into a Confined Cross-Flow. Turbulent Shear Flows II. Springer Verlag, 1979.
6. Khan, Z. A.; McGuirk, J. J.; Whitelaw, J. J.: A Row of Jets Discharging in Cross-Flow. AGARD CP-308, 1982.
7. Crabb, D.; Durao, D. F. G.; Whitelaw, J. J.: A Round Jet Normal to a Cross-Flow. ASME Trans., Vol. 103, 1981.

NUMERICAL MODELING

COMBUSTION FUNDAMENTALS

OBJECTIVE: ASSESS AND IMPROVE THE STATE OF THE ART
IN COMBUSTION MODELING

APPROACH: EMPLOY FINITE DIFFERENCE MODELS OF THE
TIME-AVERAGED NAVIER STOKES EQUATIONS

BENEFIT: AN INCREASED DESIGN CAPABILITY WITH
REDUCED DEVELOPMENT COSTS

DILUTION JETS - 3D FLOWFIELD

COMPUTATIONAL DETAILS:

20x20x12 grid	20 CPU minutes
40x30x20 grid	2 CPU hours
90x40x22 grid	10 CPU hours

RESULTS:

QUALITATIVE PREDICTION OF

1. JET PENETRATION
2. MIXING CHARACTERISTICS

LIMITATIONS INCLUDE

1. GRID DEPENDENT SOLUTIONS
2. ISOTROPIC TURBULENCE MODEL

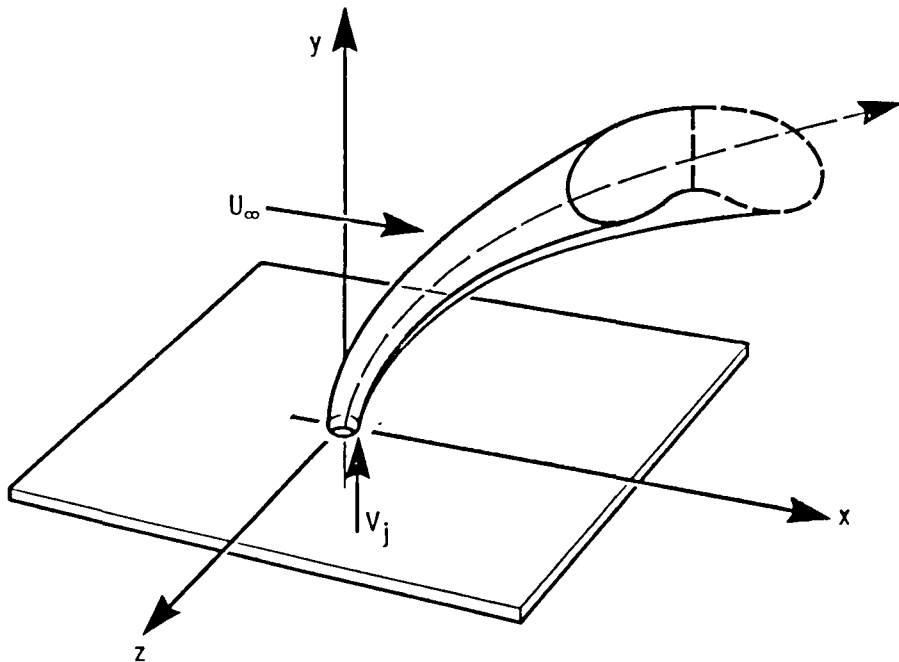

THREE DIMENSIONAL SINGLE, FREE JET FLOW FIELD SCHEMATIC.

AXIAL VELOCITY PROFILES ALONG JET CENTERLINE AT X/D=2

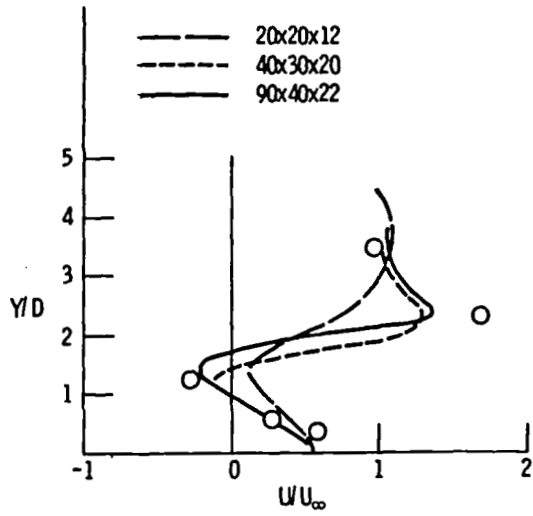

CS-82-3451

CALCULATED AND EXPERIMENTAL JET FLUID CONCENTRATION PROFILES AT X/D=8

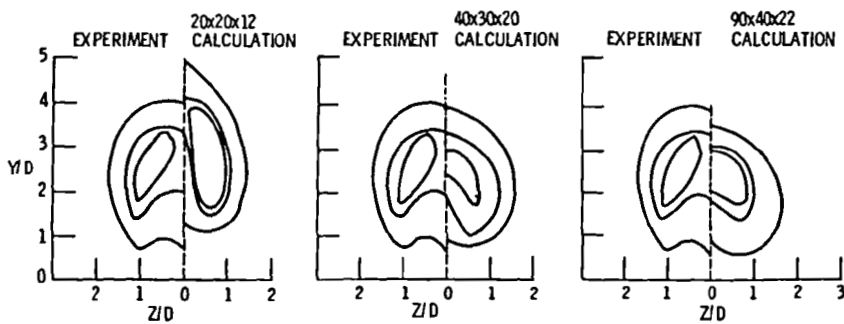

CS-82-3449

Y-Z PLANE VELOCITY VECTOR PLOTS OF TWO DIFFERENT CALCULATIONS OF THE SINGLE JET FLOW FIELD

AT APPROXIMATELY $X/D = 0.7$

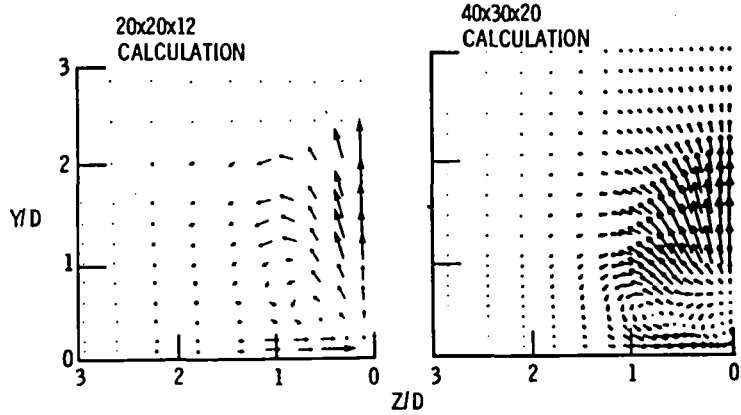

CS-82-3455

40x30x20 GRID CALCULATION

AXIAL VELOCITY PROFILES ALONG JET CENTERLINE
AT $X/D = 6$

TURBULENCE AND JET FLUID CONCENTRATION
PROFILES ALONG JET CENTERLINE AT $X/D = 6$

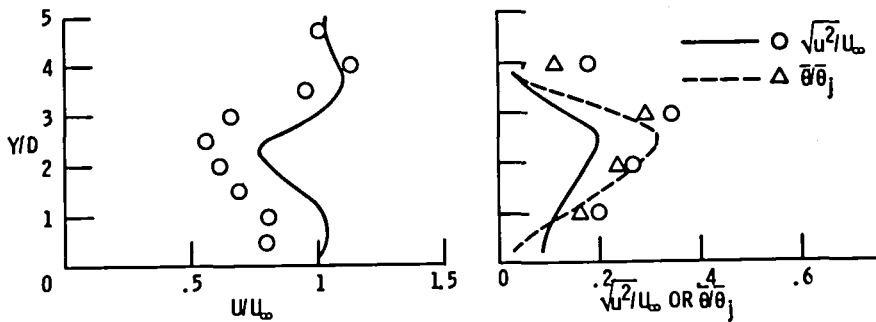

CS-82-3450

COMPARISON OF TERMS IN THE AXIAL MOMENTUM EQUATION

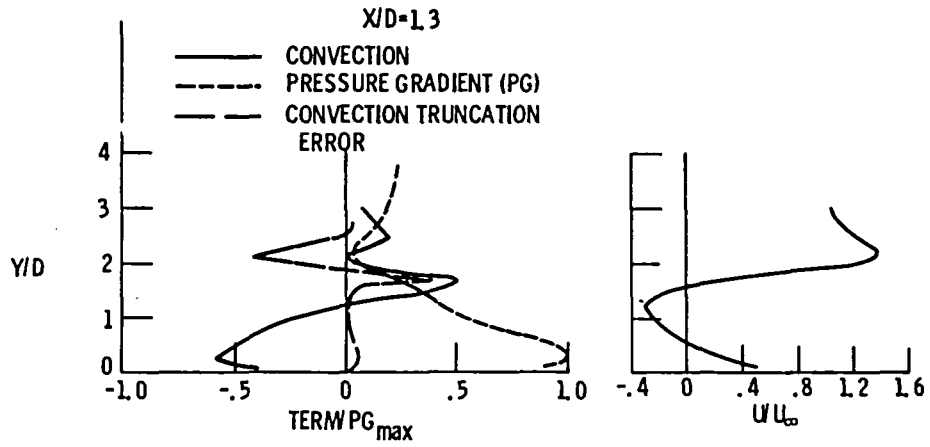

CS-82-3453