

SMALL GAS TURBINE COMBUSTOR PRIMARY ZONE STUDY

R. E. Sullivan and R. D. Sutton
Detroit Diesel Allison
Indianapolis, Indiana 46202

SUMMARY OF PRESENTATION

This talk will summarize the combustion research program sponsored by NASA Lewis Contract No. NAS3-22762, "Small Gas Turbine Combustor Primary Zone Study." Recent publication on this effort was the June 22, 1982 AIAA Paper 82-1159 authored by R. Sullivan, A. Novick, G. Miles of Detroit Diesel Allison, and by D. Briehl of NASA Lewis Research Center, who is the Project Manager.

The presentation will describe the basic elements of a design methodology program to obtain the maximum performance potential of small reverse-flow annular combustors. Three preferred combustion design approaches for internal flame stabilization patterns were selected for study. Design features were incorporated in the combustors to address the performance limiting problem areas associated with small annular combustors. Performance was predicted using a 3-D aerodynamic/chemical kinetic elliptic flow analysis, initially developed by Garrett Corporation for the USARTL. The analytical performance predictions are compared with actual test results, measured at the exit plane of the primary zone. The findings illustrate that the analytical flowfield predictive models provide a very useful design tool for understanding the combustion performance of a small reverse-flow annular combustor.

OBJECTIVE

- FORMULATE UNDERSTANDING OF PRIMARY ZONE AERODYNAMICS
 - RELATE TO PERFORMANCE OPTIMIZATION
- IMPROVE DESIGN METHODOLOGY OF REVERSE FLOW ANNULAR COMBUSTORS
 - INTERACTIVE DESIGN, ANALYSIS AND TEST

CHARACTERISTICS OF REVERSE FLOW ANNULAR COMBUSTOR

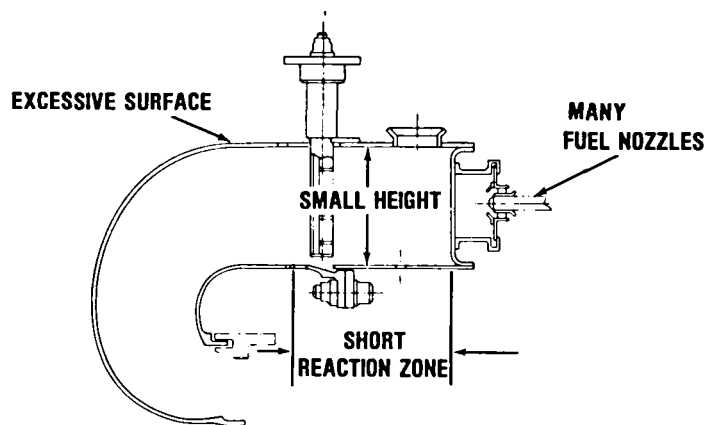

CONCERNS:

- COOLING
- ATOMIZATION
- FUEL IMPINGEMENT
- WALL QUENCHING
- REACTION TIME

COMBUSTOR PRIMARY ZONE CONCEPTS

DOUBLE VORTEX

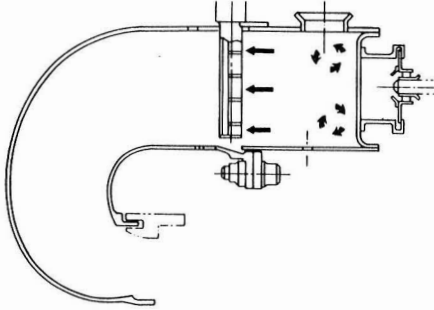

REVERSE COUNTERFLOW

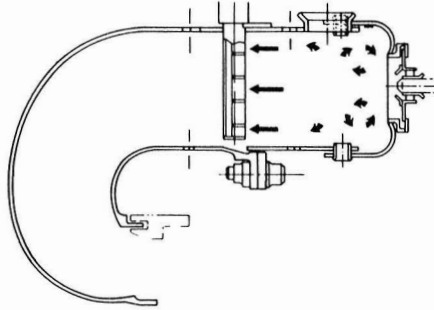

SINGLE VORTEX

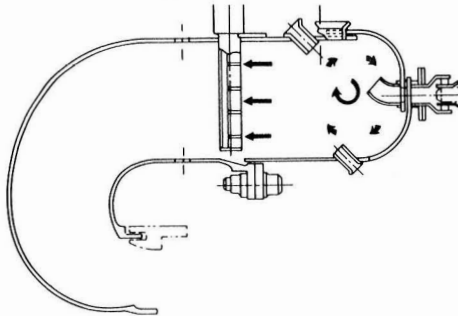

COMBUSTOR EXPERIMENTAL MEASUREMENTS - ALL CONCEPTS

COMBUSTOR OUTLET
360° TRAVERSE PROBES
PRESSURE PROBE
4 ELEMENT

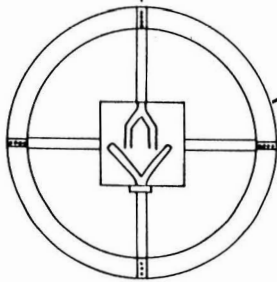

GAS SAMPLING PROBE
3 RADIAL DEPTHS

TEMPERATURE RAKE
4 ELEMENT
2 PLACES, 180° APART

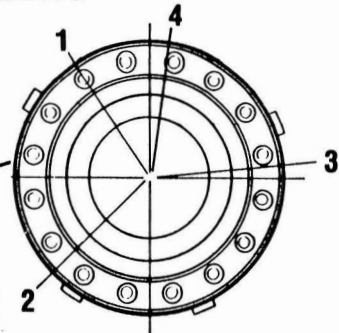
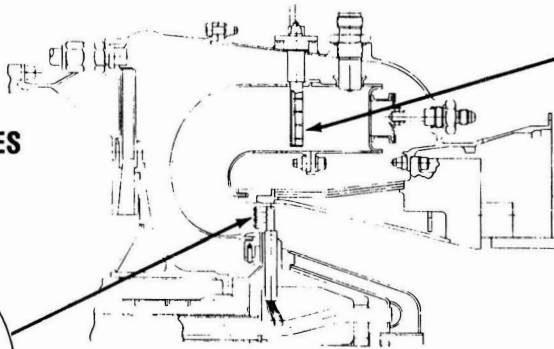

PRIMARY ZONE
PROBE LOCATIONS
4 PROBES WITH
4 RADIAL PORTS

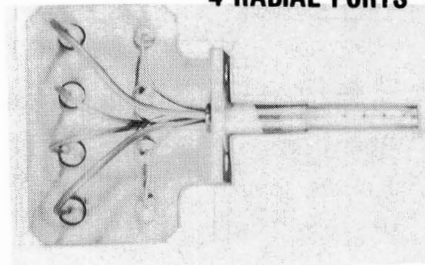

TYPICAL TEST RESULTS CONCEPT I COMBUSTOR EFFICIENCY AND EMISSIONS

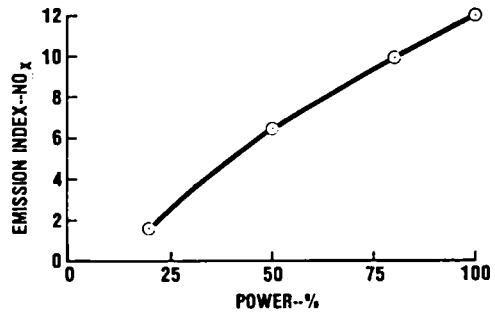
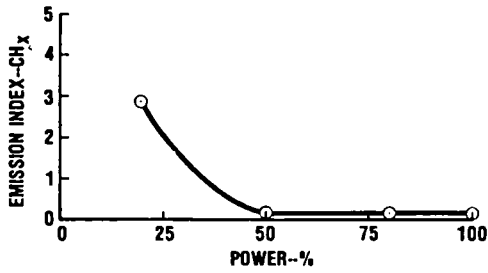
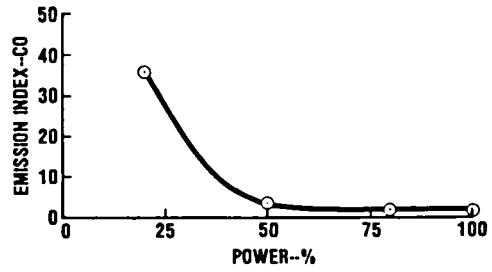
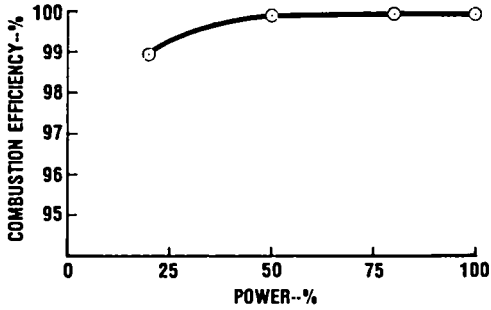

PRIMARY ZONE PROBE LOCATIONS

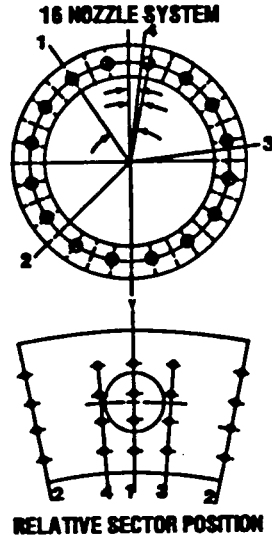
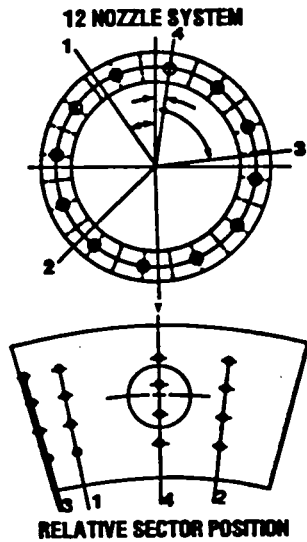

TYPICAL TEST RESULTS CONCEPT I COMBUSTOR PATTERN FACTOR

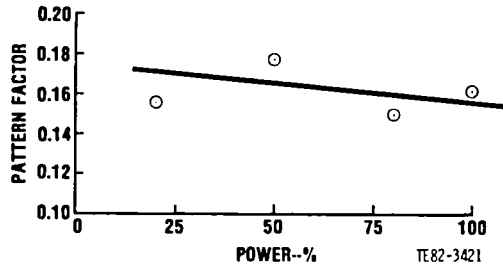
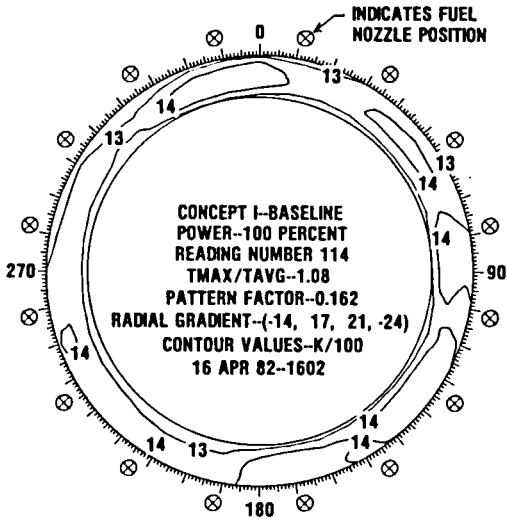

TYPICAL TEST EVALUATION AND CORRELATION WITH ANALYSIS CONCEPT I COMBUSTOR

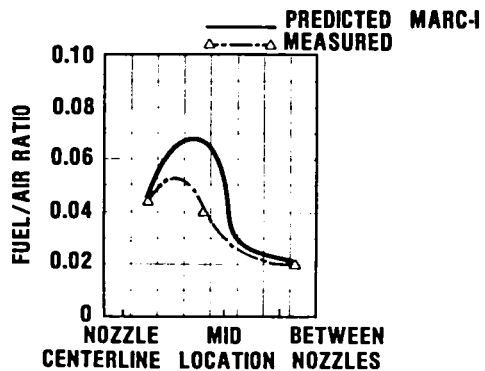
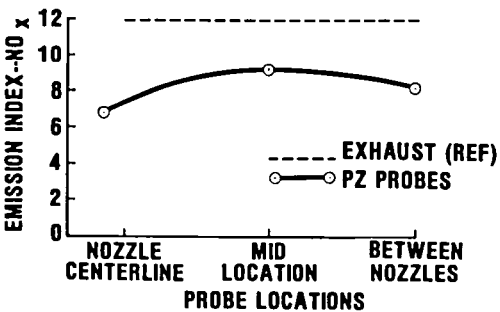
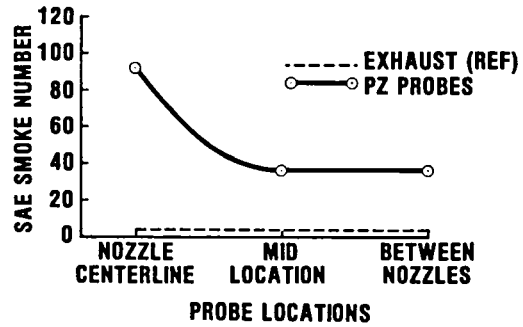
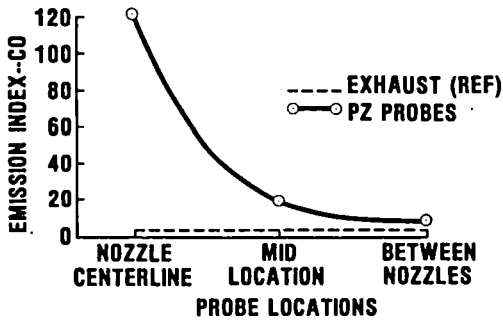

ANALYTICAL DESIGN PROCEDURE

- INCORPORATE ANALYTICAL ANALYSIS TO PREDICT FUEL-AIR DISTRIBUTION
 - DEFINE PRIMARY ZONE AERODYNAMICS
 - TAILOR FUEL PLACEMENT TO AIR PATTERNS
- CORRELATE TEST RESULTS TO UPDATE DESIGN PROCEDURES
 - USE ANALYTICAL ANALYSIS TO GUIDE COMBUSTOR MODIFICATIONS
 - RELATE OVERALL PERFORMANCE TO CONDITIONS IN PRIMARY ZONE

MARC-I CODE DESCRIPTION

- 3-D AERODYNAMIC/REACTING ELLIPTIC FLOW ANALYSIS
- ARMY/GARRETT CODE USED AS BASELINE
- PRIMITIVE-VARIABLE, FINITE-DIFFERENCE CODE
- SOLVES NAVIER-STOKES EQUATIONS IN 3-D

MARC-I CODE ELEMENTS

- K- ϵ TURBULENCE MODEL
- FUEL SPRAY VAPORIZATION MODEL
- TWO-STEP REACTION MODEL BASED ON ARRHENIUS AND EDDY-BREAKUP CONCEPTS

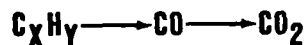

TYPICAL COMPUTER OPERATION

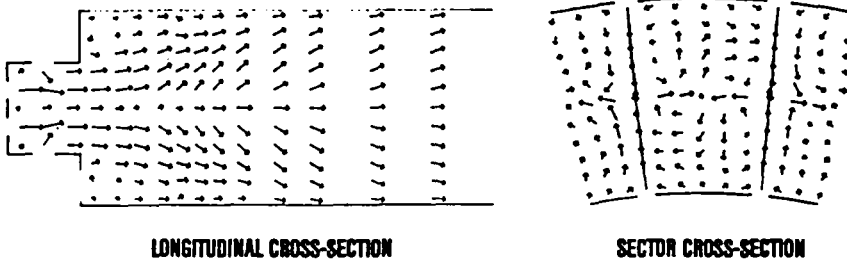

GRID SIZE: 17 X 13 X 13
REQUIRED ITERATIONS: 300 (NEW DESIGN)
100 (DESIGN REVISION)
COMPUTER TIME (IBM 370): 15 MINUTES (\$100/100 ITERATIONS)
GRID SPACING: 0.15 - 0.20 INCH

DDA MODIFICATIONS

- **GEOMETRIC REFINEMENT**
 - **PRECHAMBERS**
 - **SWIRLERS**
 - **VARIABLE DOME SHAPES**
 - **COOLING AIR ADMISSION**
- **IMPROVED DATA PRESENTATION**
 - **VELOCITY VECTOR VISUALIZATION**
 - **3-D CONTOUR PLOTS**
- **RESTART CAPABILITY**
 - **DATA STORAGE FOR SIMILAR DESIGNS**

ANALYTICAL TECHNIQUE

- MARC-I
- VELOCITY VECTOR AND TEMPERATURE CONTOUR PLOTS

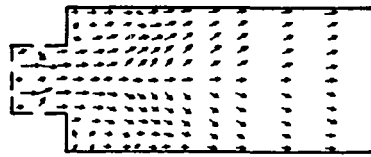

(A) LONGITUDINAL SECTION THROUGH PRECHAMBER

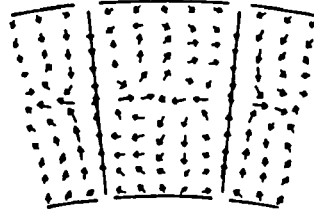

(A) VELOCITY-VECTOR PLOT

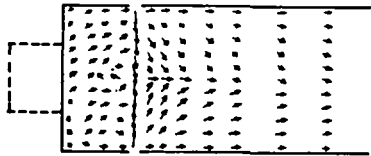

(B) LONGITUDINAL SECTION THROUGH PRIMARY HOLES

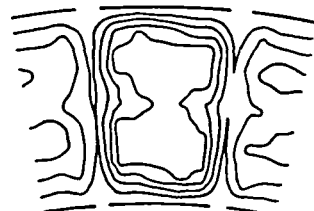

(B) TEMPERATURE CONTOUR PLOT

MARC-I

- TEMPERATURE CONTOURS (DEG F/100)

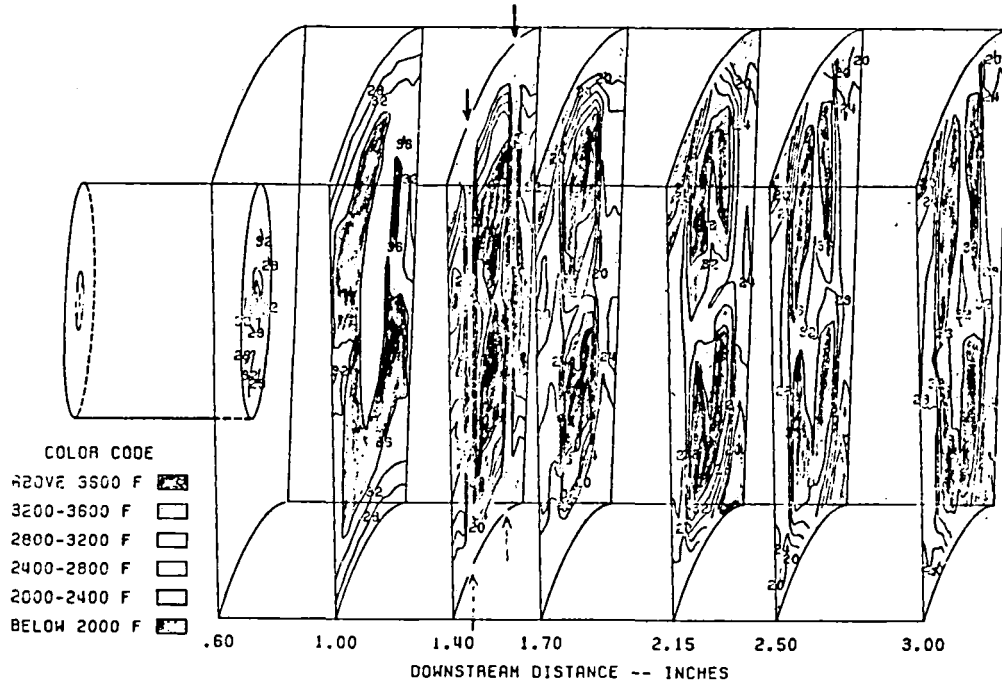

VELOCITY VECTOR PLOTS (CONCEPT II)

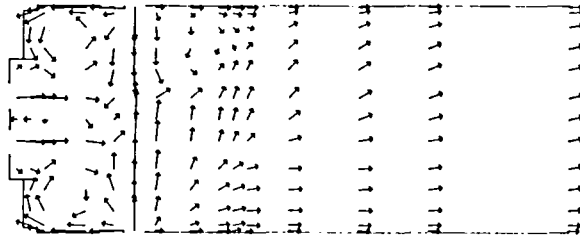

(A) LONGITUDINAL SECTION THROUGH AXIAL SWIRLER AND PRIMARY HOLES

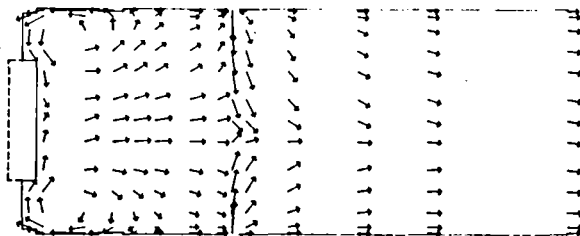

(B) LONGITUDINAL SECTION THROUGH INTERMEDIATE HOLES

VELOCITY VECTOR PLOTS (CONCEPT III)

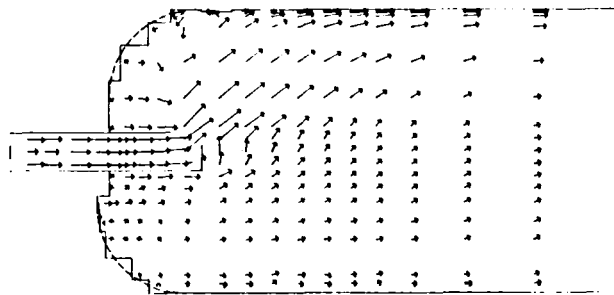

(A) LONGITUDINAL SECTION THROUGH FUEL TUBE

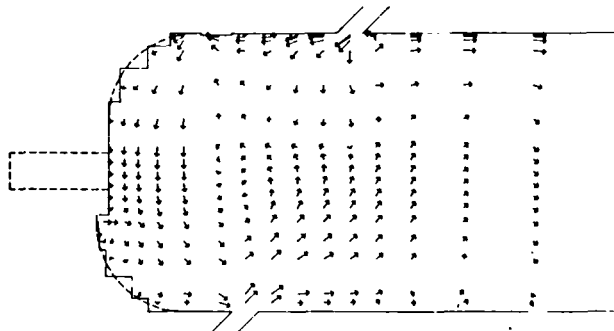

(B) LONGITUDINAL SECTION THROUGH PRIMARY BUSHINGS

PERFORMANCE OPTIMIZATION OF COMBUSTOR MODIFICATIONS

- ANALYTICAL ANALYSIS, MARC-I, USED TO GUIDE
COMBUSTOR CONCEPT I MODIFICATIONS

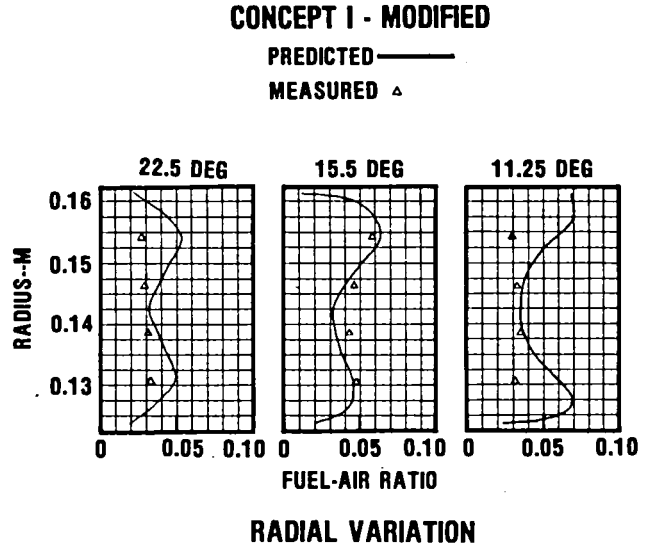
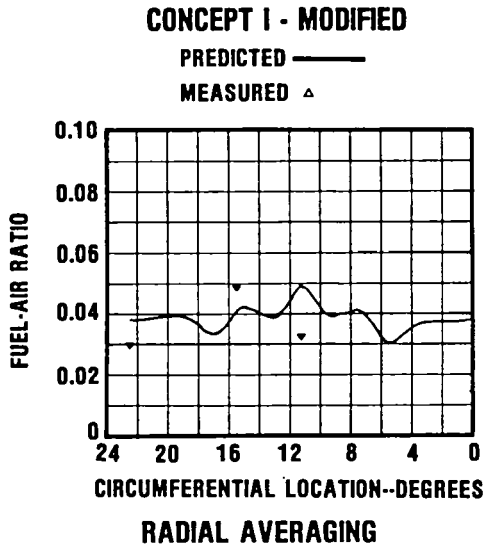

CONCEPT I - MOD I - 80-PERCENT POWER FUEL-AIR RATIO

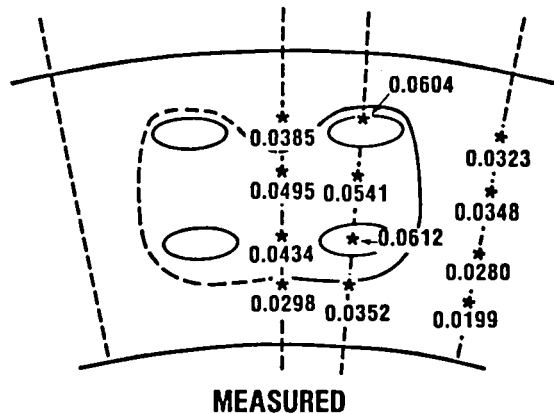
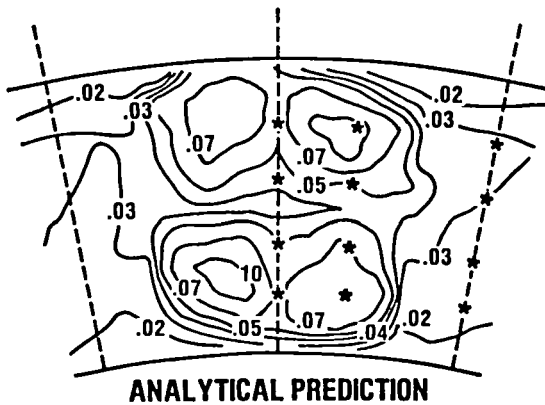

* SAMPLING REFERENCE

APPLICATION OF MARC-I TO DESIGN

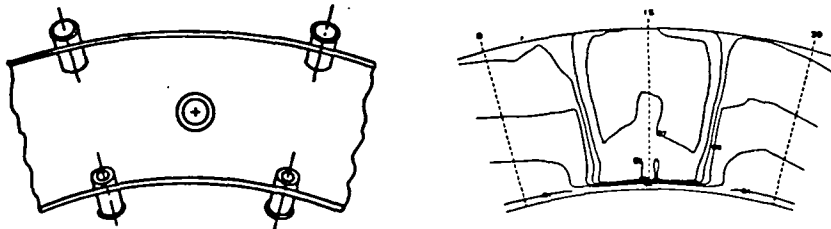

(A) CONCEPT III BASELINE SECTOR WITH FUEL-AIR PROFILE AT PRIMARY ZONE EXIT

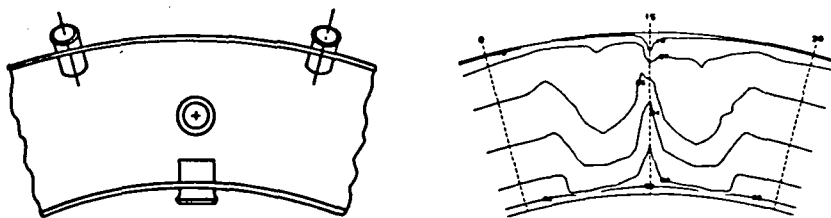

(B) CONCEPT III MODIFICATION (ADDENDUM)

SUMMARY

- USED 3-D MODEL TO DEFINE PRIMARY ZONE AERODYNAMIC AND FUEL DISTRIBUTION PATTERNS
- EXPLORED POTENTIAL OF COMBUSTOR CONCEPTS DESIGNED TO ADDRESS PROBLEMS OF REVERSE-FLOW ANNULAR COMBUSTORS
- OBTAINED PRIMARY ZONE GAS SAMPLES USING EFFECTIVELY DESIGNED WATER-COOLED PROBE
- CORRELATED PRIMARY ZONE MEASUREMENTS TO ANALYTICAL PREDICTIONS AND OVERALL PERFORMANCE