

A COMPARISON OF MEASURED AND THEORETICAL  
PREDICTIONS FOR STS ASCENT AND ENTRY SONIC BOOMS

Frank Garcia, Jr.  
NASA Johnson Space Center  
Houston, Texas

Jess H. Jones  
NASA Marshall Space Flight Center  
Huntsville, Alabama

Herbert R. Henderson  
NASA Langley Research Center  
Hampton, Virginia

Summary

Sonic boom measurements have been obtained during the flights of STS-1 through 5. During STS-1, 2, and 4, entry sonic boom measurements were obtained and ascent measurements were made on STS-5. The objectives of this measurement program were (1) to define the sonic boom characteristics of the Space Transportation System (STS), (2) provide a realistic assessment of the validity of existing theoretical prediction techniques, and (3) to establish a level of confidence for predicting future STS configuration sonic boom environments. Detail evaluation and reporting of the results of this program are in progress. This paper will address only the significant results, mainly those data obtained during the entry of STS-1 at Edwards Air Force Base (EAFB), and the ascent of STS-5 from Kennedy Space Center (KSC).

The theoretical prediction technique employed in this analysis is the so called "Thomas Program." This prediction technique is a semi-empirical method that required definition of the near field signatures, detailed trajectory characteristics, and the prevailing meteorological characteristics as an input. This analytical procedure then extrapolates the near field signatures from the flight altitude to an altitude consistent with each measurement location. Predictions of the sonic boom characteristics, i.e. arrival time, overpressure level, duration, etc., are then compared to the measured values at each location. The comparison between measured data and theoretical estimates for both the STS-1 entry and STS-5 ascent conditions showed very good agreement.

INTRODUCTION

No fully theoretical methods are available for calculating the sonic boom overpressure generated by a blunt vehicle with detached shock wave maneuvering at high Mach numbers and high angles of attack. Therefore, sonic boom estimates for Space Shuttle launch vehicles must be based on currently available semi-empirical techniques which were developed based on a large data base from supersonic aircraft flight data and wind tunnel model measurements (Refs. 1 and 2). With these techniques, near field pressure signatures measured in wind tunnels are extrapolated to the far field in a real atmosphere under actual flight conditions. In order to extend the range of conditions for which these techniques are valid, measurements were conducted in the early 1970's using the Apollo launch vehicle configurations test vehicles. Results from both of these flights are reported in References 3 and 4 and agreement between predicted and flight results was good. This agreement provided some level of confidence on the ability of semi-empirical techniques

to predict Space Shuttle sonic boom overpressure levels during ascent. These predicted levels are presently baselined as required by law in the Space Shuttle Program Environmental Impact Statement (Ref. 5).

This paper presents results based on flight pressure signature generated during entry of STS-1 (Orbiter Columbia) at Edwards Air Force Base and ascent of STS-5 from Kennedy Space Center. The STS-1 Orbiter Columbia sonic boom signatures were measured under the descent ground track from near the California coast to Edwards Air Force Base at flight conditions of  $M = 5.87$  to  $M = 1.23$ . The STS-5 ascent sonic boom signatures were measured by microphones placed aboard a ship located near the ascent focal zone approximately 71.67 kilometers (km) east of Cape Canaveral, Florida and were generated at a flight Mach number of 3.57. These pressure signatures were recorded on analog magnetic tape and were analyzed using standard data analysis principles. These measured results, i.e. peak sonic boom overpressure levels, are then compared with estimates based on wind tunnel data of Refs. 6 and 7 using the best estimate of trajectory (BET) post flight data along with the appropriate measured meteorological data using the extrapolation procedure of Ref. 1.

#### ANALYSIS METHOD AND PRESSURE INSTRUMENTATION

The theoretical prediction technique employed in this analysis is the so called "Thomas Program". This prediction technique is a semi-empirical method that requires definition of the near field signatures, detailed trajectory characteristics and the prevailing meteorological characteristics as an input. The near field signatures define the vehicle configuration in terms of shape, Mach number, and altitude; i.e. angle of attack, roll angle. This analytical procedure then extrapolates the near field signature, using the best estimate of trajectory (BET) post flight data as well as the meteorological data acquired in the vicinity of the measurements, from the flight altitude to an altitude consistent with each measurement location. The details of this technique are described fully in Ref. 1.

An integral part of this prediction method is, of course, the near field signatures. These signatures, in effect, define the source characteristics of the vehicle under consideration. These near field signatures have been acquired through wind tunnel testing for both the STS Orbiter entry conditions as well as the Shuttle ascent conditions. These data are contained in Ref. 6 and 7. For the STS ascent configuration, the effect of the exhaust plumes (Space Shuttle Main Engine and Solid Rocket Booster) is significant and this "plume effect" was modeled and is included in these near field signatures characteristics. Post flight trajectory data for both ascent and reentry was used in the theoretical analysis and was based on the best estimate of trajectory (BET) data. A detailed description of the BET data used is presented in Refs. 8 and 9.

Meteorological data was acquired for STS-1 entry from Rawinsonde observations near the ground track (station 2) which was located 93 km from the landing site. These observations were taken approximately 3 hours before and during STS-1 landing on April 14, 1981. Measured values of temperature, wind direction, and speed as a function of altitude were obtained. These results are given in detail in Ref. 8. Balloon data were obtained up to an altitude of about 28,062 meters. Atmospheric data above 28,062 meters are based on a Global Reference Atmosphere obtained from the National Weather Service.

For the STS-5 ascent conditions, Rawinsonde and Rocketsonde observations were taken at the Cape Canaveral Air Force Station, FL along with local climatological data (surface temperature, relative humidity, surface wind and direction) obtained from the Shuttle landing facility at the Kennedy Space Center, FL and station No. 2 (USAF- LCU ship) positioned approximately 71.67 km downrange from the launch site. These atmospheric soundings were taken at 52 hrs., 25 hrs., 13 hrs., 5 hrs., 1.5 hrs., and 1 hr. before liftoff on November 11, 1982. Measured values of windspeed and direction, temperature, dewpoint, and pressure were merged together from Rawinsonde, Rocketsonde, and surface data to give a sounding profile for altitude from the surface to approximately 36576 meters. A detailed description of these results are provided in Ref. 9.

The sonic boom data acquisition system utilized for the Space Shuttle STS-1 reentry and STS-5 ascent sonic boom pressure measurement program is commercially available and is similar to that used in measurements of aircraft sonic boom signatures (Ref. 10) and for measurements taken during the Apollo 16 and 17 sonic boom measurement programs (Refs. 11 and 12). These systems consist of pressure transducers, Dynagages (oscillator detector circuits), signal conditioning amplifiers, FM magnetic tape recorders, and satellite time code receivers. Specifically, the pressure transducer is a commercially available condenser microphone with a high frequency response to 10 kHz when used with the model DG-605 Dynagage system, with the low-end frequency response of approximately -5dB at 0.01 Hz. A photograph of a typical data acquisition system is shown in Fig. 1.

Fig. 2 depicts a block diagram of a typical instrumentation system for sonic boom data acquisition. Typically, each measurement station recorded six channels of overpressure data, a time code signal, and voice annotation. The output of the microphones was routed through appropriate signal conditioning amplifiers which allowed various sensitivities to be obtained for a range of preselected levels. This is a precaution necessary to allow for uncertainty in the prediction method or anomalous overpressure levels caused by unusual atmospheric, vehicle maneuvering or other focusing conditions.

#### STS-1 ENTRY CONFIGURATION AND MEASUREMENT DESCRIPTION

The STS-1 Orbiter Columbia was launched from the Kennedy Space Center, Florida on April 12, 1981, at an inclination of 40.3°. The mission had a duration of 2½ days, and the Orbiter Columbia reentered the earth's atmosphere over the mid-Pacific Ocean between Guam and Hawaii. The Columbia landed on the dry lake bed at EAFB approximately 81.49 km downrange of the reentry interface which occurred at an altitude of 121320 m.

A schematic of the STS-1 Orbiter Columbia (descent configuration) whose sonic boom levels were measured during entry is shown in Fig. 3. The Orbiter Columbia is a lifting vehicle capable of maneuvering and landing much like an airplane by using its control surfaces which are augmented by a reaction control system. As such, during its atmospheric flight, it is capable of flying at angles of attack as high as 40 degrees and rolling about the velocity vector to +70 degrees. Columbia has an overall length of 32.7 meters and had a gross weight at entry interface (121 951.2 meters altitude) of 90 720 kg during the STS-1 mission.

Sonic boom measurements were made at eleven stations (locations) along the reentry ground track and are shown in Fig. 4. In order to define these locations, a pre-flight STS-1 sonic boom analysis was performed based on the final pre-flight

predicted STS-1 Operational Flight Profile for a nominal entry into EAFB. This analysis defined the theoretically desired locations for the eleven sonic boom stations, shown in Fig. 4., by a circled number (0-10) and located near the entry ground track shown as a dashed line. The predicted overpressure levels at those locations were used to set the six signal conditioning amplifiers at each station. Selection of the recommended measurement station locations was based on several considerations. Since the primary objective of the sonic boom measurement program is to verify the theoretical technique used to predict sonic boom overpressures (Ref. 1) the station locations were distributed across the flight Mach number range for which wind-tunnel-measured pressure signatures exist in order to verify the near field data base. Consequently, the layout of the measurement stations on this flight was designed primarily to confirm the longitudinal trend of overpressure level with Mach number and secondarily, the lateral trend of overpressure with Mach number in the area of expected high overpressures. The majority of the station locations was selected to capture overpressure in the region of maximum predicted overpressure level which occurs in the immediate vicinity of the EAFB lake bed. This selection criteria also has the advantage of locating the measurement stations in the part of the entry ground track least affected by atmosphere and trajectory dispersions, thus maximizing the probability of obtaining useful data.

#### STS-1 ORBITER ENTRY RESULTS AND DISCUSSION

Six measurement channels were made at each station location. Five are located in the ground plane and one was placed at a simulated ear-level position; i.e. 1.5 meter elevation. Each of the six measurement channels were ranged differently (calibrated) in anticipation of the possible variation of levels about the nominal or predicted level. In the discussion that is to follow, only the primary ground level measurement (channel 1) and the ear level position measurement (channel 5) will be presented. All measurement stations were near the nominal or predicted level and consequently, these channels provide the most sensitive and better quality measurement.

Selected sonic boom signatures (instantaneous pressure time history) for Orbiter entry at Edwards are presented in Fig. 5a through 5h. These results are plotted for a .8 second time period and are given in Newton/(meter)<sup>2</sup>, (N/m<sup>2</sup>) for each of the eleven measurement stations. The energy arriving at a given ground location, originates at a specific region along the flight path; i.e. Mach number. For stations which are located generally below the flight path, the Mach number at which the energy originates, decreases as the Orbiter approaches the landing site. With decreasing Mach number, the decrease in the duration of the sonic boom signatures are to be expected. This is evident in Fig. 5a through 5h when comparing station 0 with station 10; i.e. Mach 5.9 with Mach 1.23. Also evident in these figures is the effect of the difference in arrival time between the incident and reflected pressure; i.e. delay time's at the ear level measurement.

All measurements were inspected for any other type of signal events for a period of 2 minutes before and after the sonic boom arrival time of the signatures presented in Fig. 5a through 5h. Only measurements at stations #4 (Camron Canyon) and station #9 (North Edwards) show the effect of a small reflected wave arriving after the primary sonic boom wave. Analysis indicate that these waves (Fig. 6 is presented as an example) are due to reflections from near-by hills rather than from the direct propagation of energy from a different region along the flight path. The peak positive and negative sonic boom levels and the duration for each location are summarized in Table I.

Detailed analysis of the rise time of each signature at each measurement station has also been conducted. A typical example of the rise time is presented in Fig. 7 for a 50 millisecond time interval for both the ground plane measurement and the ear level position measurements for station 7.

The distinct difference in arrival time between the incident and ground reflected wave is clearly evident; i.e., the reflected wave is delayed in time from the incident wave, i.e., delay time,  $\delta$ . Because the ground plane and ear level position measurements were located at slightly different positions with respect to the sonic boom wave front, the arrival times at these positions were slightly different, as can be seen. For consistency, the sonic boom arrival times at each location are determined using the ground plane measurement (channel 1) and are also summarized in Table I.

Estimates of the ground reflection factor can be made with the aid of the ground plane and ear level measurements. Under simplifying assumptions of a plane wave front that is uniform over these two positions and because the incident wave (at the ear level position) is separated in time from the reflected wave, reasonable estimates are possible. It can be shown, that if the ground plane measurements are divided by the ear level measurement and if the results are restricted to the time interval during which only the incident wave is present (in the ear level measurement) then the result will provide reasonable estimates of the reflection factor; i.e.,  $R_f$ . This operation was performed at each measurement station and the results are also presented in Table I. A typical example for station 7 is presented in Fig. 8. The ear level measurement had to be shifted in time before the ratio was performed to account for the slightly different arrival time at the ground plane and ear level location. The reflection factor estimates were obtained by averaging the reflection factor time signal over the latter position of the signals, see Fig. 8.

The duration of the Orbiter entry sonic boom signatures are quite long. They range from 375 milliseconds at  $M = 1.23$  to 700 milliseconds at  $M = 5.87$ . Because of these long durations, the predominant energy of these signatures occur at frequencies well below the normal hearing range of the human auditory system. Spectral analysis of the STS-1 reentry signatures have been performed and typical results are presented in Fig. 9 through 11.

When performing spectral analysis of transient signals, such as the sonic boom signature, energy spectral density (ESD) functions should be used instead of power spectral density (PSD) functions normally employed in analyzing stationary random signals. The spectral analysis results presented are typical of those at the other locations. In Fig. 9 and 10, this analysis is presented for a maximum frequency range of 2500 Hz. The rapid decay of energy with increasing frequency is clearly evident in these results. Also, the effect of the ear level microphone (channel 5 in Fig. 10) elevation is clearly evident. This height introduces additional lobing in the frequency spectrum. The analysis bandwidth resolutions in these spectra is 1.22 Hz.

Fig. 11 is presented in order to show in more detail, the characteristics of the lower frequency portion of the spectra; i.e. below 100 Hz. The analysis bandwidth here is .244 Hz. The low frequency character of the STS-1 sonic boom signatures is clearly evident with the peak frequency slightly over 2 Hz and the characteristic 6 dB/octave roll off of these type of signals.

The sonic boom signatures for all ground plane measurements are delineated in Fig. 12 in "iso-time history" format. The complete character of the STS-1 Orbiter entry sonic boom time histories is vividly illustrated.

As indicated earlier, the technique described in Ref. 1 was used to extrapolate the near field overpressure signature from flight conditions to the ground level. The process of identifying both the initial near field signature and the trajectory state, which correspond to the ground overpressure measurements recorded at a given station, is iterative in nature. It consisted of a search on both the trajectory state and its corresponding field signature which were systematically varied until the conditions of the ground wave intersection point and the station location are matched. Table II is a summary of the results of this search and shows for each station the pertinent trajectory conditions, signature ray angle, and the measured and predicted overpressures. As can be seen, the comparison between the measured and predicted levels are good. The predicted overpressure distributions as a function of lateral distance from the ground track for two selected Mach numbers are shown in Fig. 13 and 14 along with the measured results. Again, the comparisons are good. Complete description of these STS-1 results are contained in Ref. 8.

#### STS-5 ASCENT CONFIGURATION AND MEASUREMENT DESCRIPTION

A schematic of the STS-5 launch vehicle (ascent configuration) whose sonic boom levels were measured during ascent is shown in Fig. 15. The launch vehicle consists of an orbiter, an external tank, and a booster made up of two solid rocket motors. The solid rocket motors burn in parallel with the orbiter main propulsion engines and are separated from the orbiter/external tank and burnout (~ 48000 meters altitude). Thereafter the orbiter main propulsion engines continue to burn until the orbiter is injected into the required ascent trajectory. The launch vehicle configuration consists not only of the elements depicted in Fig. 15 but also of the exhaust plumes generated by the orbiter propulsion system and the solid rocket motors. These exhaust plumes have a significant effect on the ascent sonic boom characteristics. The STS-5 vehicle was launched on November 11, 1982 from launch pad 39-A at Kennedy Space Center on a five day mission with subsequent orbiter landing at the EAFB dry lake bed in California. The launch vehicle has an overall length of 56.3 meters and had a gross liftoff weight of 2036422 kg.

Nine measurement stations were planned to be acquired during ascent of STS-5. The pre-flight location for these measurements was determined by a procedure similar to that described for the STS-1 entry measurements. The data acquisition system was to be deployed aboard ships at these locations. These measurement locations were selected primarily to acquire sonic boom overpressure characteristics in the STS-5 ascent focal zones from near the ground track out to lateral cut-off.

At the time of launch, due to the high sea state conditions off-shore and the restricted ship size only ship number 2 could be deployed to its preplanned location and consequently only data at this station was obtained.

#### STS-5 ASCENT RESULTS AND DISCUSSION

As indicated above, data was acquired only at one station location during STS-5 ascent; i.e., station 2. For this ascent configuration, no ear level measurements were made, consequently all channels for ship number 2 location were placed in simulated ground plane position.

Ship number 2 was located 71.67 km down range and the sonic boom energy which arrived at this position was generated at a flight ascent Mach number of 3.57 and a flight altitude of 34086 meters.

The ship location, along with the predicted ground overpressure at  $M = 3.57$ , is shown in Fig. 16. The detail signature characteristics recorded at ship number 2 position is presented in Fig. 17. The measured positive peak overpressure level is  $175.2 \text{ N/m}^2$  psf. As can be seen, this signature exhibits multiple peaks and it has the long slow recovery in the expansion part of the waveform which is associated with launch vehicles with large exhaust plumes. The multiple peaks are consistent with the ascent signature obtained in the focal region during ascent of Apollo 17 (Ref. 12) and is typical of that associated with sonic boom near focal zones in general. The third peak in the signature (Fig. 17) is believed to be caused by energy arriving at this location that originated earlier during the flight than the energy which caused the initial peak. Because of the acceleration and curvature effects of an ascending vehicle, the sonic boom wavefront tends to become folded, thus generating the multiple peaks (see Ref. 13). In general, with increasing downrange distance from the focus, the separation between the first and third peak will tend to increase. The separation between first and third peak is only 1.3 sec, which is another indication that ship number 2 was very near the STS-5 ascent focal zone. The exact nature of the third peak is under further study to verify these observations. It is not clear as to the origin of the second peak and it is also under further study. However, because of the folded nature of the wavefront in this region it is probably associated with dispersion of the energy from the nearby focus or an overhead focus.

Ascent (launch vehicle) signatures do not have the classical N-wave type of signature typically associated with fighter aircraft or the Shuttle Orbiter configuration, for example. This long duration waveform and its slow recovery is a direct result of the effect of Space Shuttle's exhaust plumes. The N-wave type signature results from bodies (vehicle) with distinct termination from front to rear, which is not the case for launch vehicles. However, the first initial rise time is consistent with N-wave type signatures.

Using the extrapolation method of Ref. 1 with the BET post flight data and the measured meteorological data, the predicted sonic boom overpressure level at ship number 2 is  $148.4 \text{ N/m}^2$ . This compares favorably with the  $175.2 \text{ N/m}^2$  level that was measured. The initial portion of the predicted waveform is also shown in Fig. 17, and as can be seen, the comparison is very good. Complete description of these STS-5 results are presented in Ref. 9.

#### CONCLUDING REMARKS

This paper presents sonic boom pressure signatures recorded during the entry of the STS-1 Orbiter Columbia and ascent of the STS-5 Space Shuttle. During STS-1 entry, peak overpressure levels were recorded at eleven measurement stations and they ranged in level from  $33.16 \text{ N/m}^2$  to  $114.91 \text{ N/m}^2$ . Predicted peak levels and duration of the positive portion of the N-waves using a semi-empirical technique correlated well with the measured data. Analysis of signature characteristics showed that the ground reflection factor varied from 1.83 to 2.09. A reflection factor of 1.9 was used for predictions. The frequency analysis of the STS-1 signatures showed that the peak frequency of the orbiter during entry is on the order of 2 Hz.

Also, comparison of sonic boom levels predicted and measured at one station location during ascent of the STS-5 Space Shuttle Mission was presented. A peak overpressure level of  $175.2 \text{ N/m}^2$  was measured during ascent generated from an altitude of 34086 meters at  $M = 3.57$ . In addition to this initial peak, two other peaks of lower intensity were also observed. The signature was not a simple N-wave in shape, however, it exhibited a rapid rise time and number of intermediate shocks which are associated with the near focus boom region resulting from the curved, accelerating flight profile of the STS-5 launch vehicle. The predicted overpressure level of the sonic boom signature utilizing semi-empirical techniques correlated well with the measurement. Follow-on work will include detailed signature analysis of the measured data and further study of the origin of the additional peaks.



## REFERENCES

1. Thomas, C. L.: Extrapolation of Sonic Boom Pressure Signatures by the Waveform Parameter Method. NASA TN D-6832, June 1972.
2. Hayes, W. D., Haefeli, R. C., and Kulsrud, H.: Sonic Boom Propagation in a Stratified Atmosphere, with Computer Program Rept. No. 116, Aeronautical Research Associates of Princeton, Inc., Dec. 1968.
3. Hick, Raymond M., Mendoza, Joel P., and Garcia, Frank: A Wind Tunnel-Flight Correlation of Apollo 15 Sonic Boom. NASA TM X-62111, January 28, 1972.
4. Garcia, Frank, Hicks, Raymond M., and Mendoza, Joel P.: A Wind Tunnel-Flight Correlation of Apollo 16 Sonic Boom. NASA TM X-62C73, Feb. 5, 1973.
5. Malklin, M. S.: Environmental Impact Statement for the Space Shuttle Program. NASA Headquarters, NASA TM 82278, 1978.
6. Mendoza, Joel P.: Wind Tunnel Pressure Signatures for a .0041-Scale Model of the Space Shuttle Orbiter. NASA TM X-62432, May 1975.
7. Ashby, George C.: Near-Field Sonic Pressure Signatures for the Space Shuttle Launch and Orbiter Vehicles at Mach 6. NASA Technical Report 1405, April 1979.
8. Garcia, Frank, Jones, J. H., and Henderson, Herbert R.: Preliminary Sonic Boom Correlation of Predicted and Measured Levels for STS-1 Entry. NASA TM-85242, Feb. 1982.
9. Garcia, Frank, Jones, J. H., and Henderson, Herbert R.: Preliminary Sonic Boom Correlations of Predicted and Measured Levels for STS-5 Launch. NASA TM 58253, April 1983.
10. Proceedings of the Sonic Boom Symposium. Journal of Acoustical Society of America, Vol. 39, No. 5, May 1966, pp S1-S80.
11. Henderson, Herbert R., and Hilton, David A.: Sonic Boom Ground Pressure Measurements from the Launch and Reentry of Apollo 16. NASA TN D-7606, 1974.
12. Henderson, Herbert R., and Hilton, David A.: Sonic Boom Measurements in the Focus Region During the Ascent of Apollo 17. NASA TN D-7806, 1974.
13. Holloway, Paul F., Wilhold, Gilbert A., Jones, Jess H., Garcia, Frank, Hicks, Raymond M.: Shuttle Sonic Boom - Technology and Prediction, AIAA paper No. 73-1039, Oct. 1973.

TABLE I

STS-1 SONIC BOOM OVERPRESSURE CHARACTERISTICS

STATION NO.	MEASUREMENT LOCATION CHANNEL NO.	PEAK OVERPRESSURE LEVEL		TOTAL TIME DURATION (SEC)	RISE TIME (MSEC)	BOOM ARRIVAL TIME GMT (M.M.S)	REFLECTED SIGNAL DELAY (MSEC)	REFLECTION FACTOR
		POSITIVE (N/m <sup>2</sup> )	NEGATIVE (N/m <sup>2</sup> )					
1	1	33.15	27.39	.693	4.4	18:13:28:432	8.6	1.34
	5	34.33	31.85	.700	4.2			
2	1	58.41	54.58	.563	5.0	18:14:47:579	9.6	1.97
	5	51.77	57.9	.588	5.0			
3	1	44.53	41.18	.530	4.0	18:15:08:729	9.0	2.27- 2.32
	5	38.30	38.3	.538	4.0			
4	1	54.58	53.98	.525	4.4	18:15:29:283	8.2	2.09
	5	50.75	56.98	.531	4.2			
5	1	76.61	73.74	.491	4.8	18:15:54:266	8.6	2.00
	5	68.47	67.03	≈.497	4.6			
6	1	75.17	72.78	.402	≈4.4	18:16:20:651	9.0	1.98
	5	75.17	74.21	≈.414	≈4.4			
7	1	114.91	105.82	.354	4.0	18:16:33:797	5.7	-
	5	86.18	90.01	.406	-			
8	1	93.85	84.75	.380	≈4.0	18:16:54:366	7.2	1.65
	5	101.03	90.97	.393	-			
9	1	86.66	79.00	.375	5.0	18:17:11:449	5.4	1.98
	5	81.40	Clipped	Clipped	5.0			
10	1	108.21	90.49	.375	3.6	18:17:08:634	5.4	1.90
	5	94.32	89.54	.380	2.8			
11	1	89.04	83.31	.375	1.8-3.2	18:17:17:103	5.8	1.83
	5	79.48	105.82	.380	≈1.8			

\* Channel 5 very noisy.

ORIGINAL PAGE IS  
OF POOR QUALITY

TABLE II  
COMPARISON OF PREDICTED AND MEASURED OVERPRESSURE LEVELS

STATION	FLIGHT TIME FROM ENTRY INTERFACE (SEC)	MACH NUMBER	ALTITUDE (m)	RAY* ANGLE (DEG)	RAY TRAVEL TIME (SEC)	PREDICTED $\Delta P$ (N/m <sup>2</sup> )	RECORDED $\Delta P$ (N/m <sup>2</sup> )
0	1334	5.87	39337	-8.5°	129.7	35.91	33.25
1	1431	3.94	32876	-11	111.5	48.26	58.41
2	1462	3.41	30401	-2	101.3	55.88	44.53
3	1491	2.97	27899	+10	92.1	54.44	54.53
4	1527	2.39	24953	+2	82.6	71.58	76.61
5	1556	1.98	23054	-4	79.4	87.48	78.04
6	1573	1.76	21552	-4	75.1	92.75	114.91
7	1596	1.45	19447	0	73.0	92.98	93.23
8	1596	1.45	19447	-36	90.6	75.17	86.63
9	1600	1.40	19103	+30	83.9	80.63	108.22
10	1616	1.23	17770	-6	76.5	37.43	89.04

\*Positive left of groundtrack



Figure 1.- Typical sonic boom data acquisition system.

ORIGINAL PAGE 13  
OF POOR QUALITY

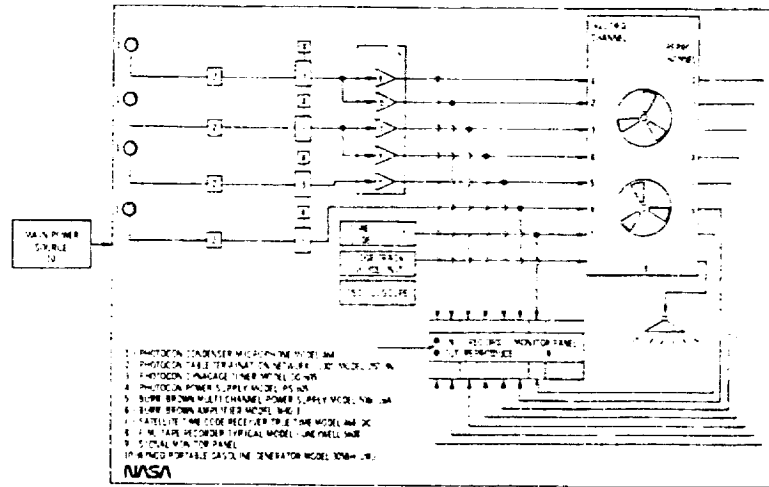

Figure 2.- Block diagram showing typical sonic boom data acquisition system.

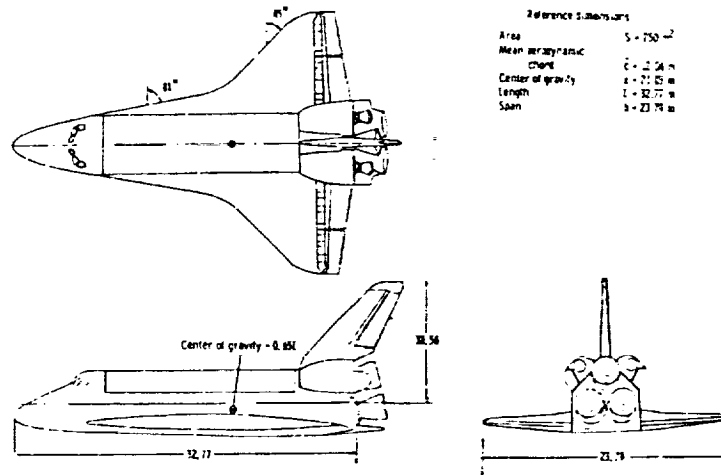

Figure 3.- Schematic of orbiter configuration.

ORIGINAL PAGE IS  
OF POOR QUALITY

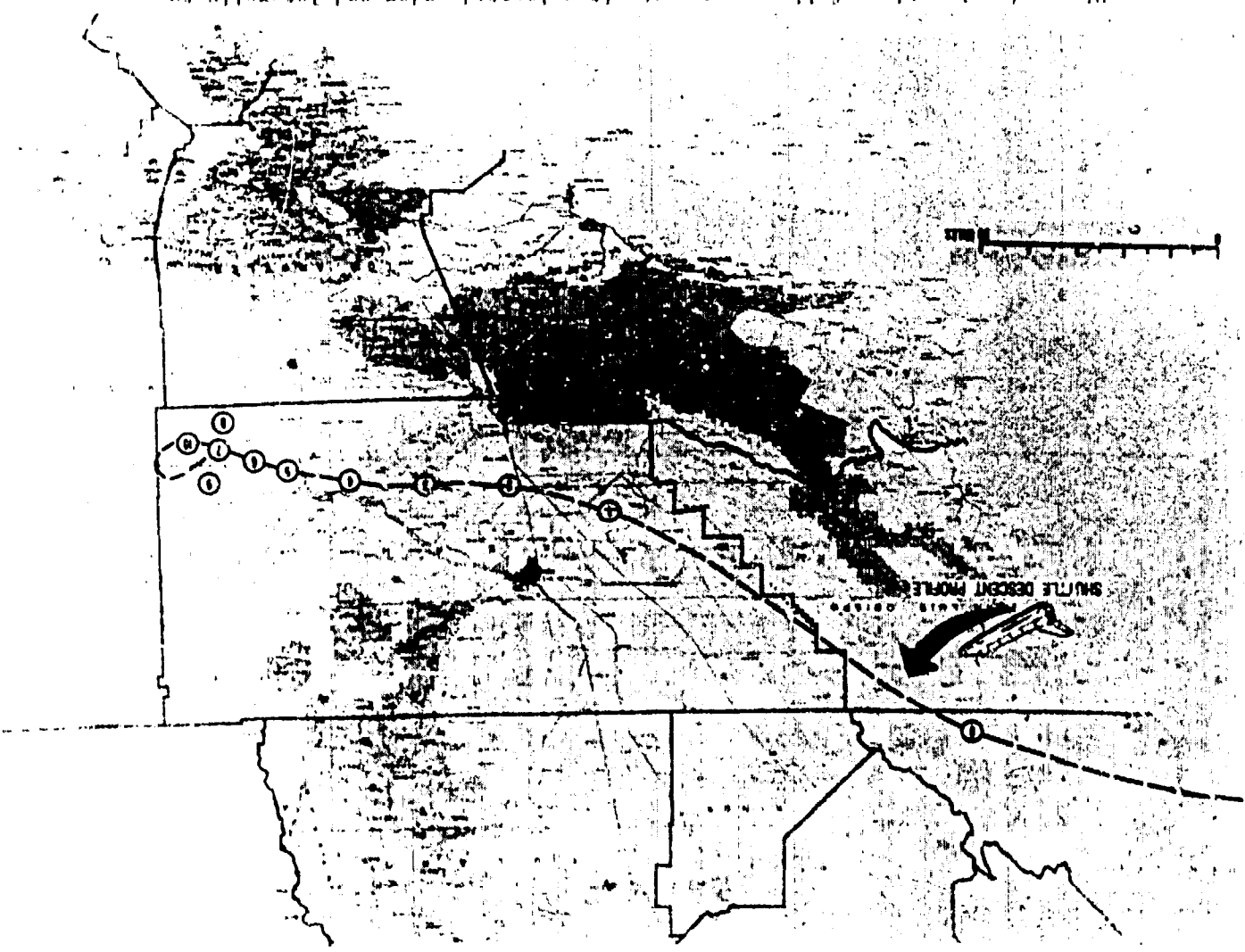
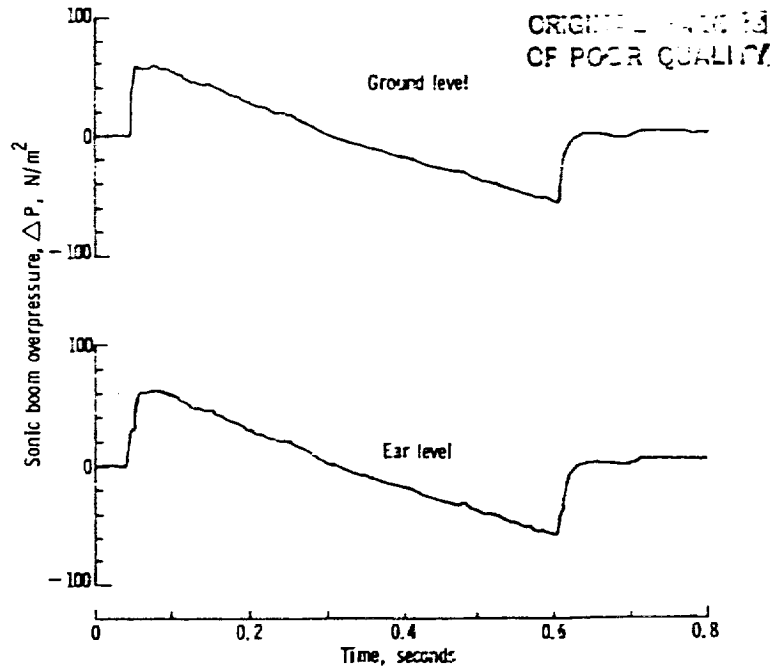
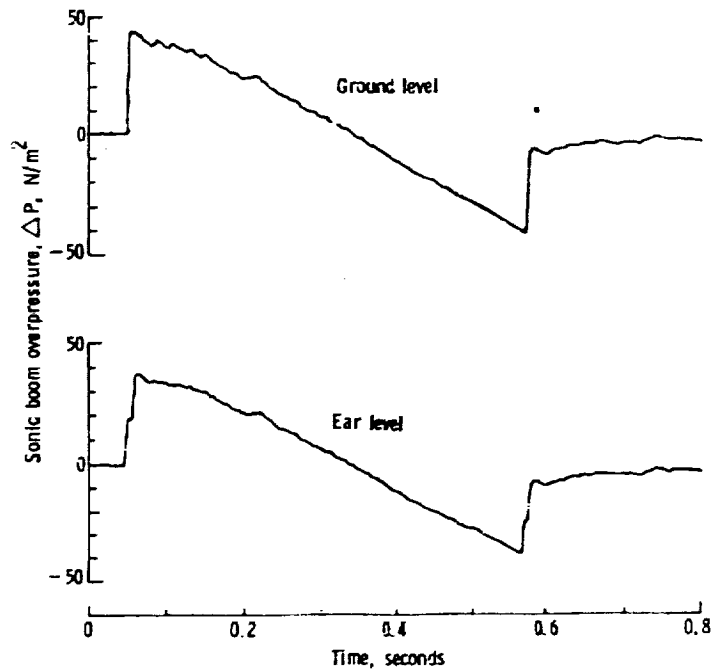

Figure 4.- Location of 11 measurement sites located under and laterally to the STS-1 reentry track into Edwards Air Force Base, CA.



(a) Station 1.



(b) Station 2.

Figure 5.- Sonic boom signature measured during reentry of STS-1 as recorded at stations 1 through 7 and station 10.

ORIGINAL PAGE IS  
OF POOR QUALITY

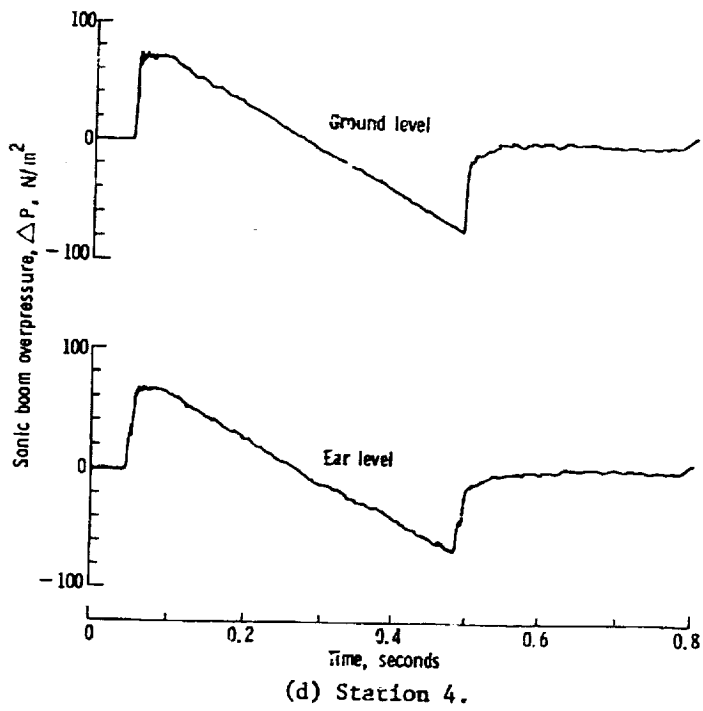
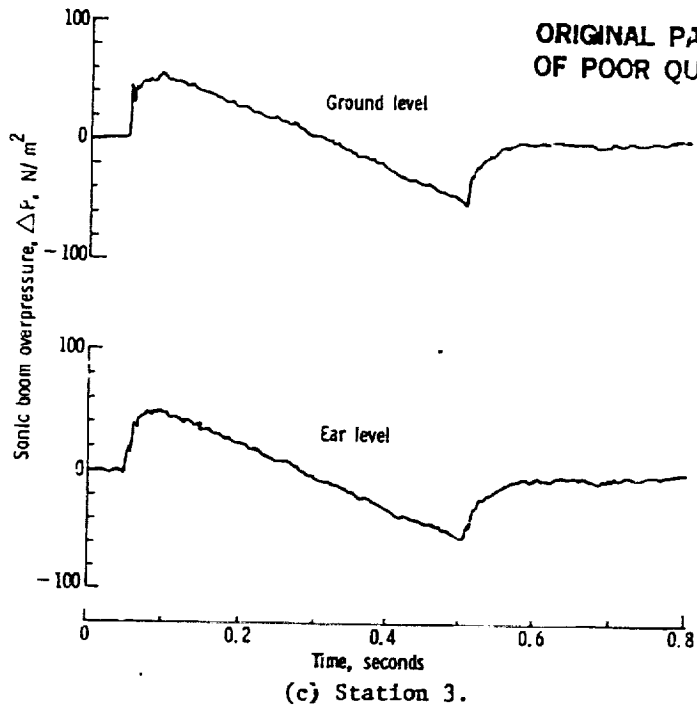
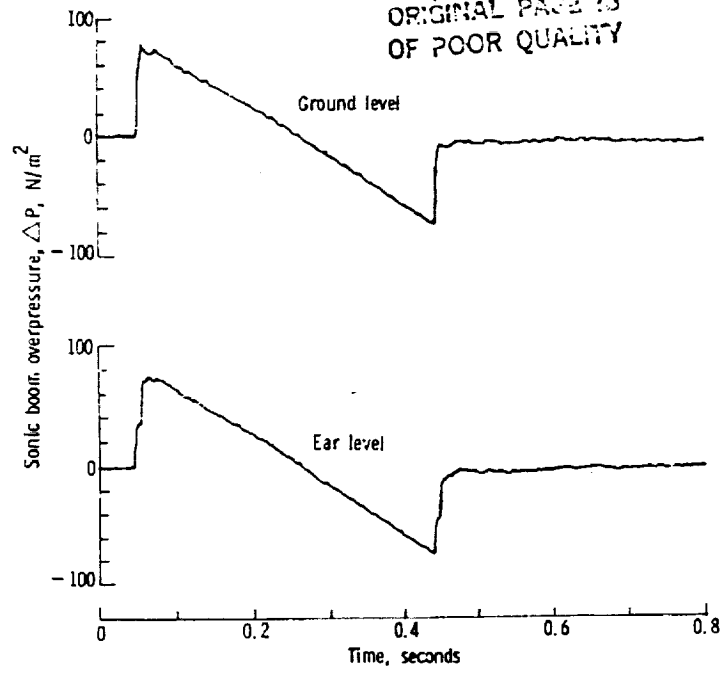

Figure 5.- Continued.



ORIGINAL PAGE IS  
OF POOR QUALITY



(e) Station 5.

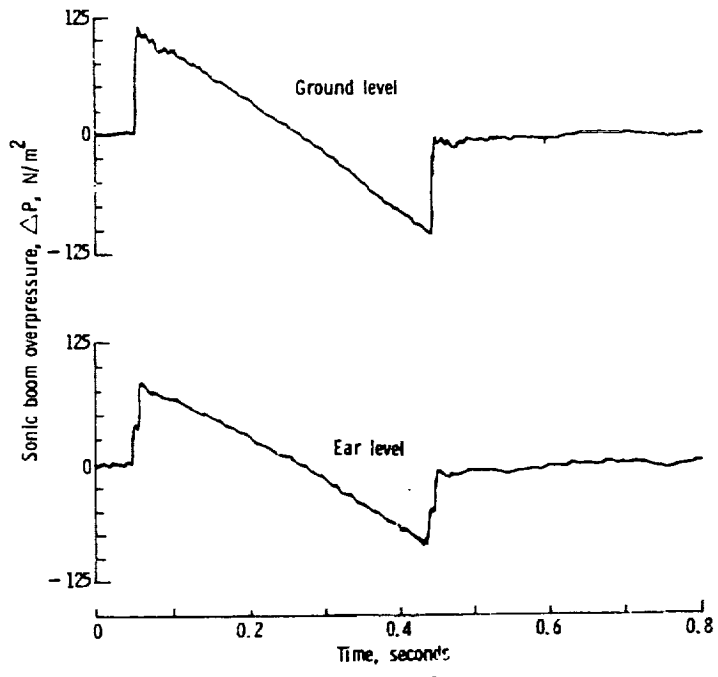

(f) Station 6.

Figure 5.- Continued.

ORIGINAL PAGE IS  
OF POOR QUALITY

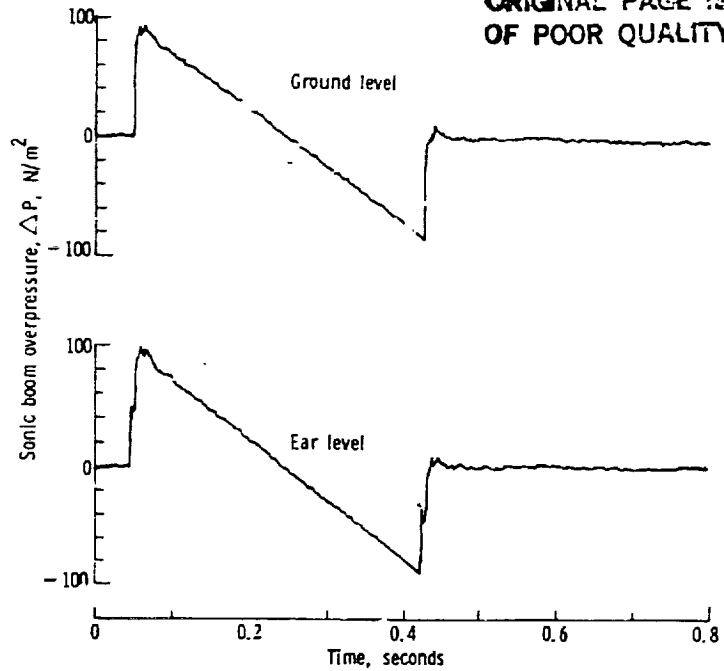

(g) Station 7.

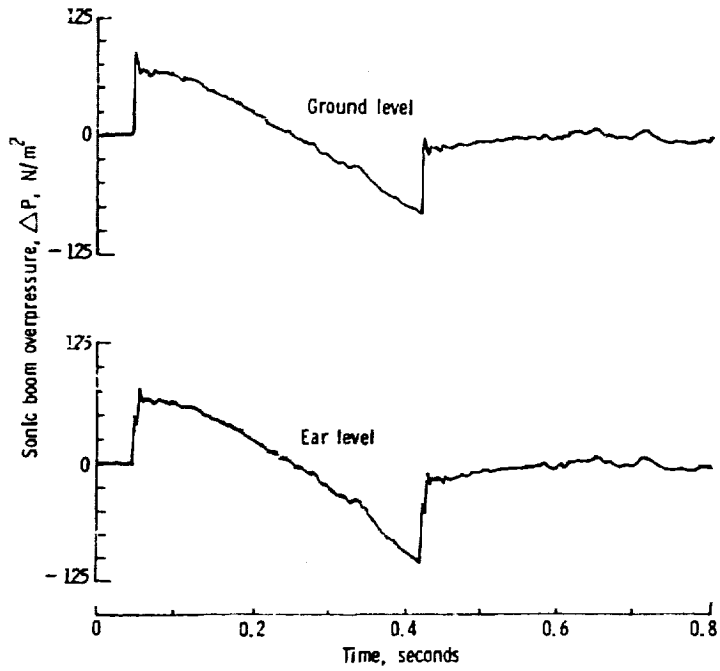

(h) Station 10.

Figure 5.- Concluded.

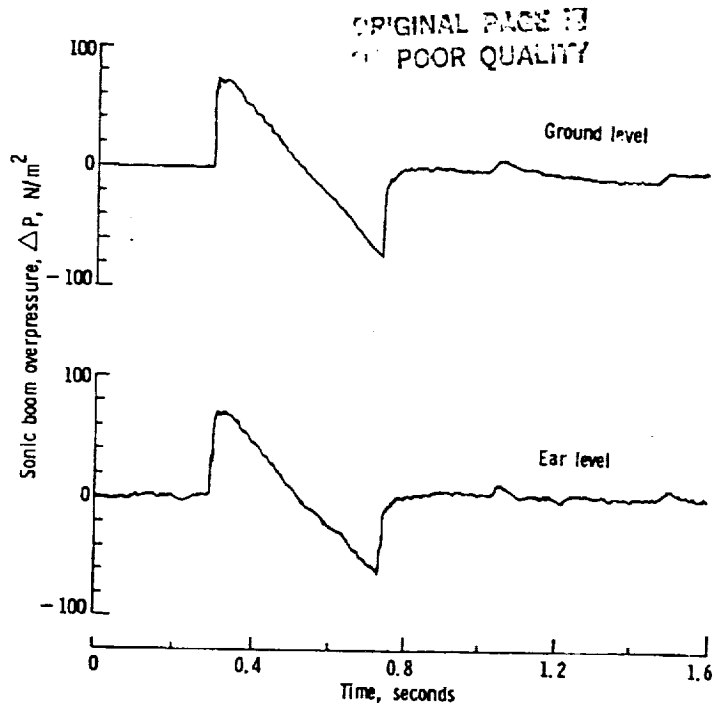

Figure 6.- Measured sonic boom signature showing reflected waves as recorded at station 4 during STS-1 reentry.

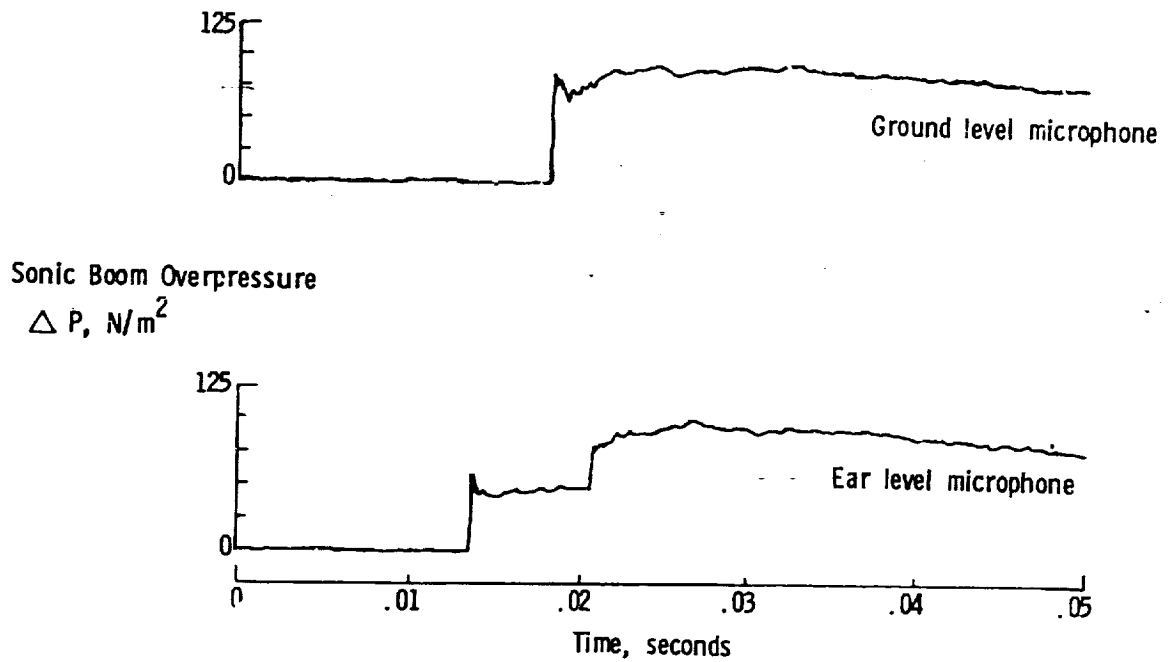

Figure 7.- Measured sonic boom signatures from station 7 during STS-1 reentry showing details of bow shock-wave rise time.

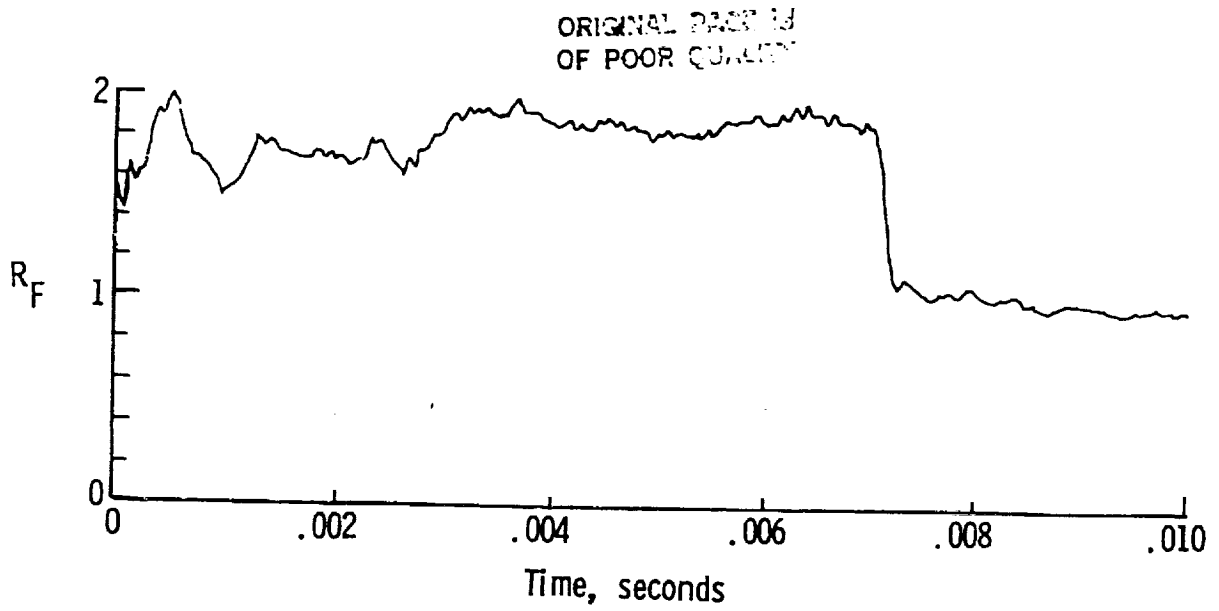

Figure 8.- Typical reflection factor time history of sonic boom signature measured at station 7 during STS-1 reentry.

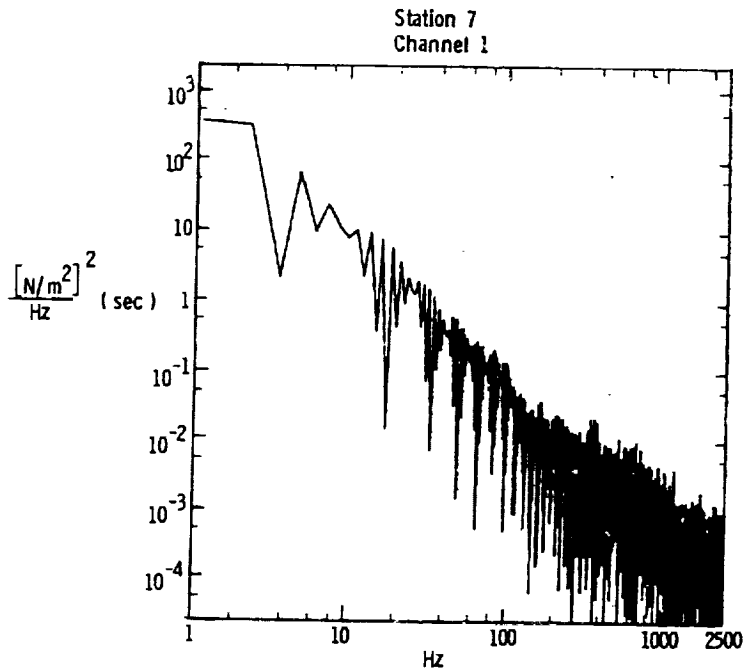

Figure 9.- Energy spectral density analysis from station 7 ground level microphone during STS-1 reentry.

Station 7  
Channel 5

ORIGINAL PAGE IS  
OF POOR QUALITY

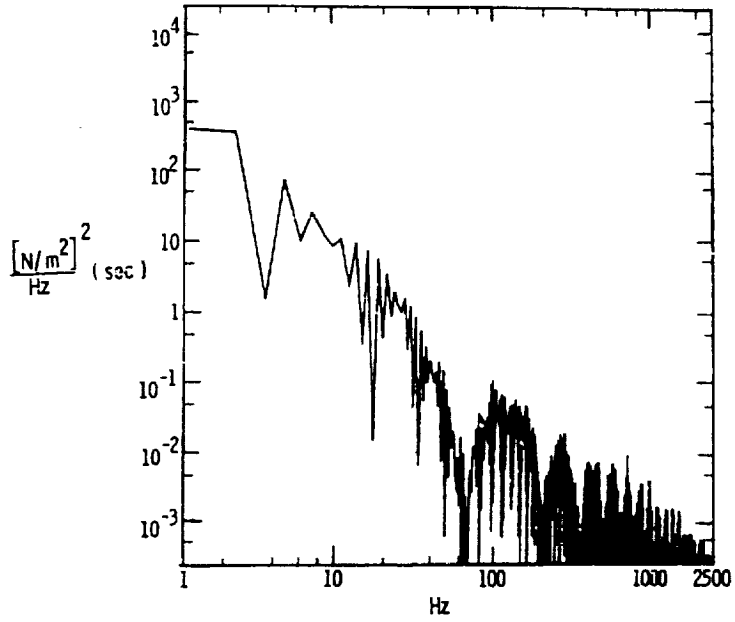

Figure 10.- Energy spectral density analysis from station 7 ear level microphone during STS-1 reentry.

Station 9  
Channel 1

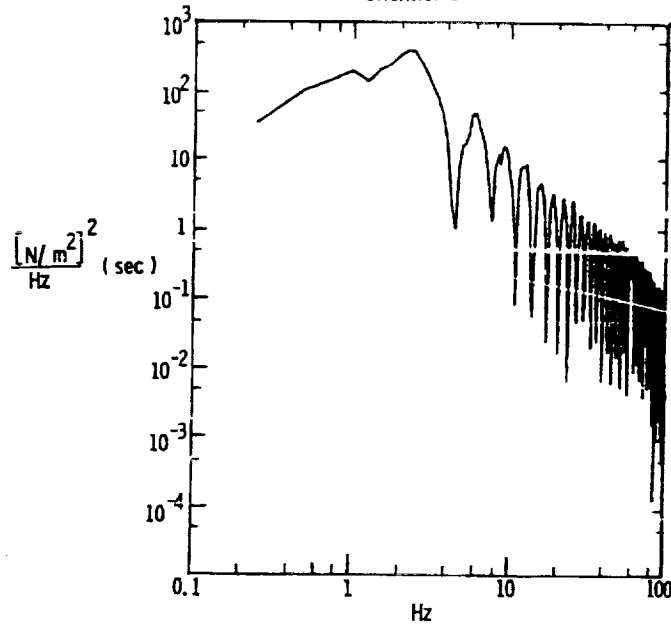

Figure 11.- Energy spectral density analysis from station 9 ground level microphone during STS-1 reentry.

ORIGINAL FIGURE 12  
OF POOR QUALITY

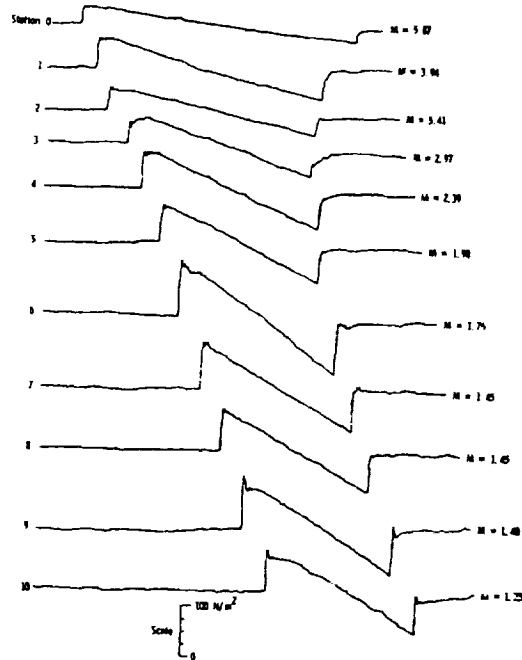

Figure 12.- Measured sonic boom signatures recorded at 11 measurement sites located under and laterally to the STS-1 reentry ground track.

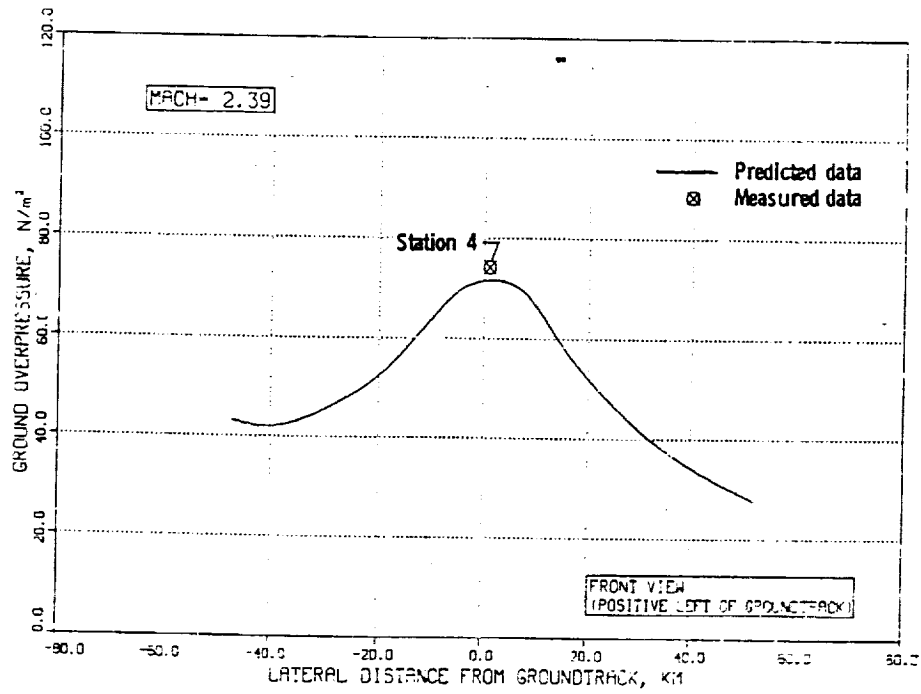

Figure 13.- Predicted and measured overpressure distribution for station 4 during STS-1 reentry.

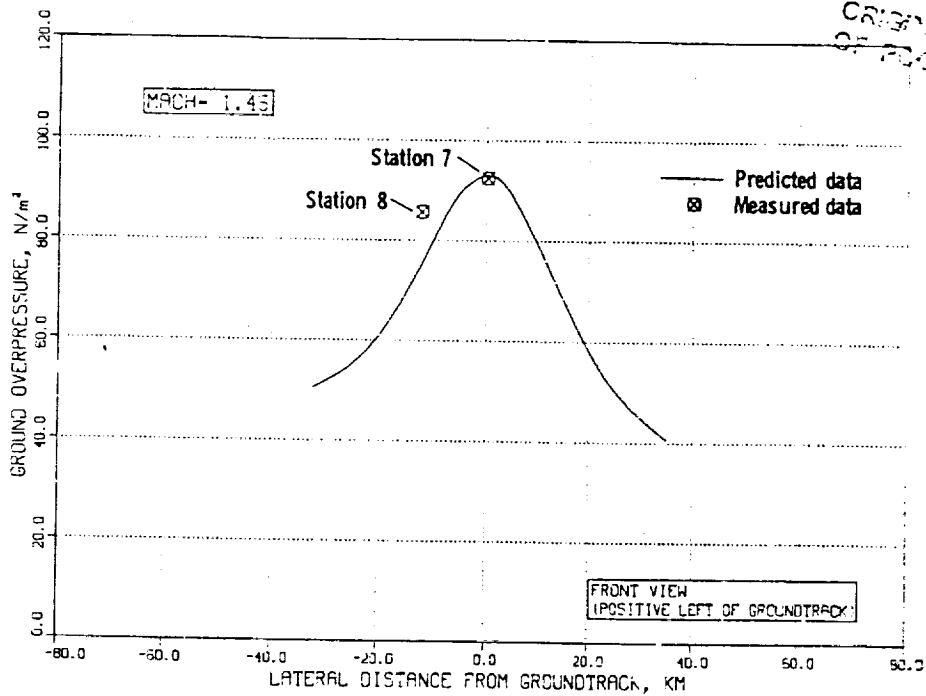

Figure 14.- Predicted and measured overpressure distribution for stations 7 and 8 during STS-1 reentry.

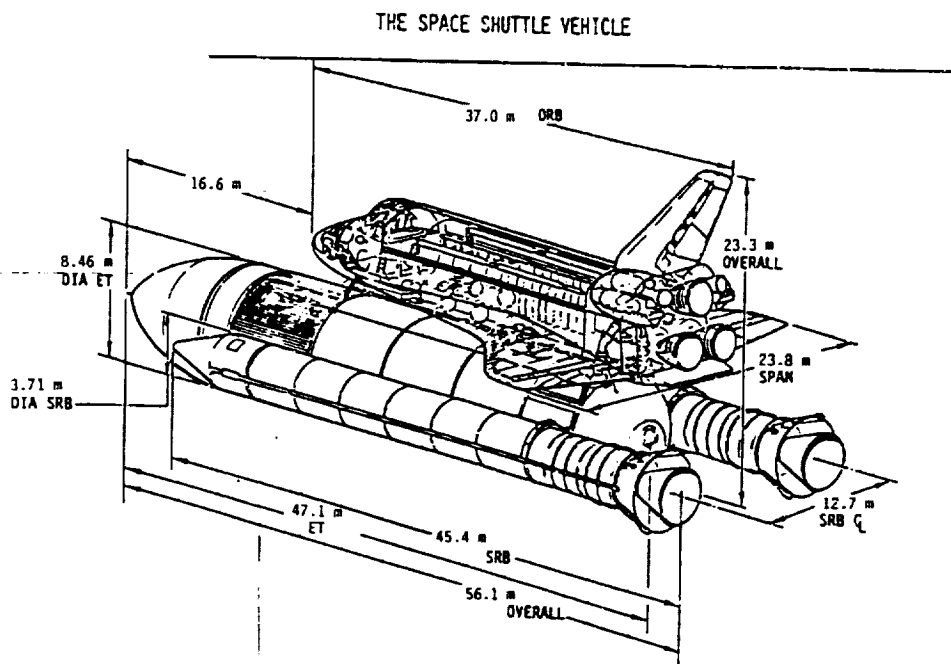

Figure 15.- Schematic of Space Shuttle launch vehicle.

Figure 17.- Overpressure signature measured during the ascent of STS-5.

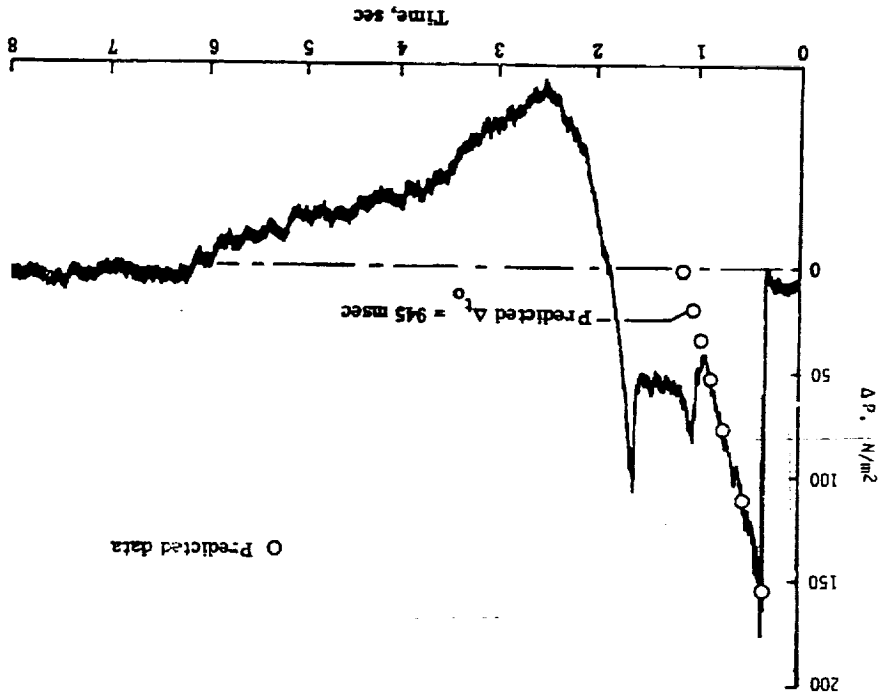
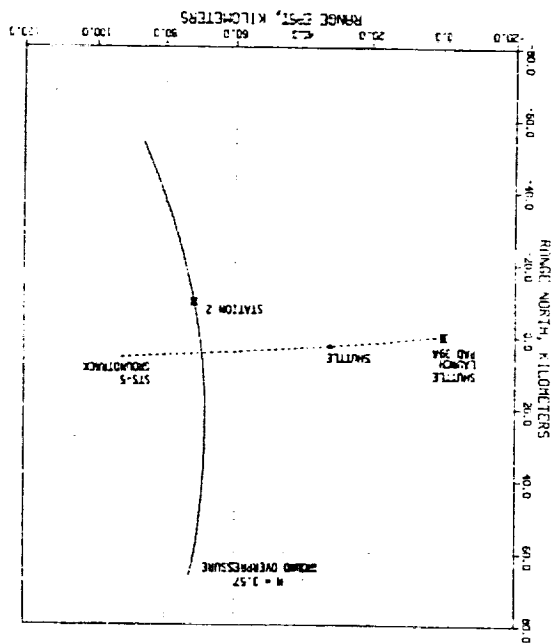

Figure 16.- Ground overpressure line at  $M = 3.57$  which intersects station 2, STS-5 ascent.



ORIGINAL PAGE IS  
OF POOR QUALITY



## SUMMARY SESSION: INTRODUCTION

The final afternoon of the Shuttle conference was devoted to overviews and summaries. The session opened with an invited paper by Mr. Robert G. Hoey of the Air Force Flight Test Center. Mr. Hoey is Chief of the Office of Advanced Manned Vehicles, and his office conducted an examination of the flight data that paralleled and frequently supplemented the NASA study. Because the pilots' reactions to the vehicle flying qualities were not discussed in the contributed papers, Major Steven R. Nagel of the Astronaut Office at Johnson Space Center was invited to present that office's viewpoint, particularly for the approach and landing phase when the vehicle was flown manually. The third and final invited paper was by Dr. Milton A. Silveira, Assistant to the Deputy Administrator, NASA Headquarters, who presented remarks concerning the Shuttle Orbital Flight Test program from a NASA and Project Office management perspective.

In the final wrap-up to the meeting, the chairpersons of the technical sessions were asked to prepare comments on significant results presented at the conference. This session was taped, and the comments were transcribed and are included here. The chairpersons and their sessions were:

Ascent Aerodynamics I - Mr. T. E. Surber of Rockwell International, Space Division

Ascent Aerodynamics II - Mr. B. B. Roberts of Johnson Space Center

Entry Aerodynamics I - Mr. J. C. Young of Johnson Space Center

Entry Aerodynamics II - Mr. D. C. Schlosser of Rockwell International, Space Division

Guidance, Navigation, and Control - Dr. K. J. Cox of Johnson Space Center

Aerothermal Environment I - Mrs. D. B. Lee of Johnson Space Center

Aerothermal Environment II - Dr. J. Bertin of the University of Texas at Austin  
(Dr. Bertin was unable to attend this summary session; his co-chairman, Mr. E. V. Zoby of Langley Research Center, spoke for him.)

Thermal Protection - Mr. H. E. Goldstein of Ames Research Center

Measurements and Data - Mr. E. R. Hillje of Johnson Space Center