

NASA Conference Publication 2290

NASA-CP-2290 19840004160

# Integrated Flywheel Technology 1983

*Proceedings of a workshop held at  
NASA Goddard Space Flight Center  
Greenbelt, Maryland  
August 2-3, 1983*



25th Anniversary  
1958-1983

**NASA**

*NASA Conference Publication 2290*

# Integrated Flywheel Technology 1983

*Edited by*  
Claude R. Keckler  
*Langley Research Center*  
*Hampton, Virginia*

Guillermo E. Rodriguez  
*Goddard Space Flight Center*  
*Greenbelt, Maryland*

Nelson J. Groom  
*Langley Research Center*  
*Hampton, Virginia*

Proceedings of a workshop held at  
NASA Goddard Space Flight Center  
Greenbelt, Maryland  
August 2-3, 1983

**NASA**  
National Aeronautics  
and Space Administration  
Scientific and Technical  
Information Branch

1983

**Page intentionally left blank**

## PREFACE

A two-day workshop on integrated flywheel systems was held at the NASA Goddard Space Flight Center in Greenbelt, Maryland, on August 2-3, 1983. The purposes of the workshop were to assess the state of the art in integrated flywheel systems technology, to determine the potential of such systems concepts, to identify critical technology areas needing development, and to scope and define an appropriate program for coordinated activity in this technology area. The workshop was limited to government personnel. A list of attendees is included in this document.

The first day consisted of a number of presentations by personnel representing NASA and the Department of Energy (DOE). These presentations provided an excellent overview of recent and current technology efforts as well as results of preliminary tradeoff and sizing analyses in the areas of power, control, and integrated systems. On the second day of the workshop, a panel consisting of one member from each of the six NASA field organizations represented was formed to address and provide guidance on the four questions of major importance to this workshop. These questions were:

- 1) What are the critical technology areas associated with the implementation of integrated flywheel systems?
- 2) What are the major systems integration issues associated with combining the functions of power and control into one spacecraft subsystem?
- 3) Does a justification exist for an advanced technology program in the area of integrated flywheel systems?
- 4) How should such a technology program be defined, and what should be some of its major steps?

The panel members presented summaries of their expert opinions regarding these questions. In addition, one panelist summarized the panel reports.

This publication contains a summary of the workshop which includes a discussion of the major conclusions and recommendations produced by the participants. In addition, copies of the various papers presented as well as the panelist summaries are contained herein.

Use of trade names or names of manufacturers in this report does not constitute an official endorsement of such products or manufacturers, either expressed or implied, by the National Aeronautics and Space Administration.



**Page intentionally left blank**

## CONTENTS

PREFACE.....	iii
ATTENDEES.....	vii
INTRODUCTION.....	1
EXECUTIVE SUMMARY.....	2

## PRESENTATIONS

INTEGRATED POWER/ATTITUDE CONTROL SYSTEM (IPACS)..... C. R. Keckler	5
GSFC FLYWHEEL STATUS..... G. E. Rodriguez	23
OVERVIEW OF STATE-OF-THE-ART FLYWHEEL TECHNOLOGY..... Mitchell Olszewski	35
EUROPEAN INTEGRATED FLYWHEEL TECHNOLOGY..... J. B. Dahlgren	47
ELECTRICAL POWER TRADE-OFFS..... Bob Giudici	49
SPACE STATION ENERGY SIZING..... Robert R. Rice	57
SPACE STATION ATTITUDE CONTROL SYSTEM CONCEPT AND REQUIREMENTS..... P. D. Nicaise	63
THE BOEING FLYWHEEL STUDY..... Robert R. Rice	71
SPACE STATION CONTROL REQUIREMENTS AND FLYWHEEL SYSTEM WEIGHTS FOR COMBINED MOMENTUM AND ENERGY STORAGE..... Frank M. Elam	77
COMBINED ATTITUDE CONTROL AND ENERGY STORAGE..... Henry Hoffman	93
IPACS ATTITUDE CONTROL TECHNOLOGY CONSIDERATIONS..... L. Brandon	99
FLYWHEEL ELECTRONICS..... Frank Nola	105
IPACS ELECTRONICS - COMMENTS ON THE ORIGINAL DESIGN AND CURRENT EFFORTS AT LaRC..... Joe C. Gowdey	117

ANNULAR MOMENTUM CONTROL DEVICE (AMCD).....	123
Nelson J. Groom	
MAGNETIC BEARINGS FOR INERTIAL ENERGY STORAGE.....	133
Philip A. Studer	
ADVANCED CONTROL AND POWER SYSTEM (ACAPS) TECHNOLOGY PROGRAM.....	141
C. R. Keckler and N. J. Groom	
POWER SYSTEM CONSIDERATIONS AND TEST ACTIVITIES.....	157
Jim Miller	
IPACS GUIDANCE NAVIGATION AND CONTROL SYSTEM CONSIDERATIONS AND TEST ACTIVITIES.....	165
H. J. Buchanan	
FLYWHEELS FOR DYNAMIC SYSTEMS.....	169
Luther W. Slifer	
ASSESSMENT OF POTENTIAL FOR BATTERIES IN SPACE APPLICATIONS.....	171
F. E. Ford	
SOME COMMENTS ON LONGEVITY BY A TECHNOLOGIST.....	175
Larry H. Thaller	

PANEL SUMMARY PRESENTATIONS

RECOMMENDATIONS FOR AN INTEGRATED POWER/ATTITUDE CONTROL SYSTEM (IPACS) TECHNOLOGY PROGRAM.....	187
W. W. Anderson	
RECOMMENDATIONS FOR COMPOSITE FLYWHEEL DEVELOPMENT.....	191
F. M. Elam	
PANEL DISCUSSION.....	195
F. E. Ford	
IPACS WORKSHOP COMMENTS.....	209
J. L. Miller	
APPENDIX - SYMBOLS AND ABBREVIATIONS.....	211

## ATTENDEES

Judith H. Ambrus  
NASA HQ/RES-5  
600 Independence Ave  
Washington, DC 20546  
202-755-3127

W.W. Anderson  
NASA LaRC  
Hampton, VA 23696  
804-865-3049

John H. Boeckel  
NASA GSFC/Code 700  
Greenbelt, MD 20771  
301-344-6213

Henry Brandhorst  
NASA HQ/RSE-5  
600 Independence Ave  
Washington, DC 20546  
202-755-8557

Larry B. Brandon  
NASA MSFC/PD12  
Huntsville, AL 35812  
205-453-5727

Lott W. Brantley, Jr.  
NASA MSFC/PD14  
Huntsville, AL 35812  
205-453-5726

Dave Byers  
NASA HQ/RSE-5  
600 Independence Ave  
Washington, DC 20546  
202-755-3127

Bill Carroll  
NASA HQ/RTM-6  
600 Independence Ave  
Washington, DC 20546  
202-755-2494

John B. Dahlgren  
NASA OAST/RTH-6  
600 Independence Ave  
Washington, DC 20546  
202-755-3273

Frank M. Elam  
NASA JSC/Avionics Division  
Houston, TX 77058  
713-483-3066

Floyd E. Ford  
NASA GSFC/Code 711  
Greenbelt, MD 20771  
301-344-5845

Bob Giudici  
NASA MSFC/H52  
Huntsville, AL 35812  
205-872-3666

Joe C. Gowdey  
NASA LaRC  
Hampton, VA 23365  
804-865-4621

Nelson J. Groom  
NASA LaRC/MS494  
Hampton, VA 23665  
804-865-3350

Henry Hoffman  
NASA GSFC/Code 712  
Greenbelt, MD 20771  
301-344-8496

Claude R. Keckler  
NASA LaRC/MS161  
Hampton, VA 23665  
804-865-4591

Richard Key  
NASA JPL/MS198-326  
4800 Oak Grove Drive  
Pasadena, CA 91109  
213-354-3160

Dr. Peter R. Kurzhals  
NASA GSFC/Code 500  
Greenbelt, MD 20771  
301-344-6521

Duncan E. McIver  
NASA HQ/RTH-6  
600 Independence Ave  
Washington, DC 20546  
202-755-3273

Jim Miller  
NASA MSFC  
Huntsville, AL 35812  
205-453-4950

P.D. Nicaise  
NASA MSFC/PD12  
7809 Bridgewell  
Huntsville, AL 35802  
205-453-3668

Frank Nola  
NASA MSFC/EB24  
Huntsville, AL 35802  
205-453-4255

Patricia O'Donnell  
NASA LeRC/MS309-1  
21000 Brookpark Road  
Cleveland, OH 44070  
216-433-4000 X6945

Mitchell Olszewski  
Oak Ridge National Lab  
P.O. Box Y  
Oak Ridge, TN 37830  
615-574-0770

Robert R. Rice  
NASA JSC/EP-5  
Houston, TX 77058  
713-483-2594

G. Ernest Rodriguez  
NASA GSFC/Code 711  
Greenbelt, MD 20771  
301-344-6202

R.A. Russell  
NASA HQ/RTH-6  
600 Independence Ave  
Washington, DC 20546  
202-755-2494

Rufus W. Shivers  
Dept. of Energy/CE141  
Washington, DC 20585  
202-252-1476

Luther W. Slifer, Jr.  
NASA GSFC/Code 711  
Greenbelt, MD 20771  
301-344-8841

Phil Studer  
NASA GSFC/Code 716  
Greenbelt, MD 20771  
301-344-5229

Lawrence H. Thaller  
NASA LeRC  
2100 Brookpark Road  
Cleveland, OH 44135  
216-433-4000 X5260

Marc Trummel  
NASA JPL  
4800 Oak Grove Drive  
Pasadena, CA 91109  
213-577-9310

James L. Williams  
NASA LaRC  
Hampton, VA 23665  
804-765-2486

## INTRODUCTION

The first OAST Integrated Flywheel Technology Workshop was held at NASA Goddard Space Flight Center, Greenbelt, Maryland, August 2-3, 1983. The purposes of this workshop were to assess the state of the art in integrated flywheel systems technology, to determine the potential of such system concepts, to identify critical technology areas needing development, and to scope and define an appropriate program for coordinated activity in this technology area. To accomplish these goals, participants from NASA Headquarters and NASA field centers as well as representatives of the Department of Energy (DOE) reported on the various tradeoff and sizing analyses as well as on the concept technology programs conducted by each organization. A list of workshop attendees is provided in this document. In addition, a panel comprised of one member from each of the six represented NASA field centers addressed itself to the questions of critical technology, system integration, technology program justification, and definition. Panel members are listed in table 1.

TABLE 1

Integrated Flywheel Technology Workshop Panel Members

Panel Member	Affiliation
W. W. Anderson	Langley Research Center
F. M. Elam	Johnson Space Center
F. E. Ford	Goddard Space Flight Center
J. L. Miller	Marshall Space Flight Center
L. H. Thaller	Lewis Research Center
M. C. Trummel	Jet Propulsion Laboratory

## EXECUTIVE SUMMARY

An assessment of the state of the technology applicable to integrated flywheel systems was initiated by reviewing those programs that deal with kinetic energy storage for either space or terrestrial applications. A summary of the Integrated Power/Attitude Control System (IPACS) program trade studies and system performance studies was presented, along with the follow-on technology enhancement efforts to demonstrate the viability of such storage/control concepts. The conceptual design of a kinetic energy storage system utilizing a pair of counter-rotating, composite material rotors suspended on magnetic bearings was described, along with some applications study results. The data obtained from these two technology programs indicated that significant potential benefits could be realized in the applications of these concepts to a large variety of Earth orbital spacecraft. Overviews of DOE efforts and European interests in the various technology areas associated with integrated flywheel systems were provided. The DOE program concentrated on satisfying automotive, as opposed to spacecraft, energy demands through the use of flywheels. Such applications pose significantly different constraints on the system designs which limit the direct transfer of technology from one program to another. However, the DOE effort does establish a large database on the use of composite materials in flywheels. European technology is concentrating on composite material rotors and magnetic suspension. It was also indicated that European interest in cooperative efforts in these areas is very high.

Following the broad-scope reviews of these technology programs, summaries of system trade studies and sizing efforts were presented in the areas of power, energy storage, and attitude control. In addition, descriptions of technology advancements in electronics, control actuators, and magnetic bearings were highlighted. A technology program proposal for advancing the technology associated with integrated flywheel systems for application to a space station mission was outlined. Power system considerations in using an IPACS concept as well as required test activities to validate this technology for use in a space station mission were also introduced.

Based on these presentations and attendant discussions, as well as on its combined expert opinion, the panel arrived at the general consensus that integrated flywheel systems offer a strong alternative to conventional electrochemical systems for meeting the requirements associated with a space station mission. It is therefore recommended that a strong flywheel technology program be initiated in FY 85 and that seed funds be provided in FY 84 to permit the generation of a detail program plan for this effort. One essential step to this process, which was stressed by the panel and other participants, is the need for a second workshop on flywheel technology with industry and government-wide participation to be conducted as soon as possible. This workshop would address not only technology, but also systems application issues as related to the IPACS concept. Several critical items of this technology needing further definition and advancement were identified by the panel. Among these were:

- 1) Application of composite materials to high-speed/high-stress flywheels for use in a space environment.
- 2) Magnetic suspension system for long-life and reliable operations.
- 3) Generation and testing of individual critical components as necessary steps of technology evolution which must be followed by an integrated system test effort in order to reflect the true performance capability of the flywheel concepts.

- 4) Efficient electronics and motor/generators to reduce the size of system supporting elements such as solar arrays and thermal radiators.
- 5) System integration and modularity to insure compatibility with other onboard systems and to permit application of this technology to other missions such as small unmanned satellites.
- 6) On-orbit maintenance to reduce logistics costs.
- 7) Detailed evaluation of control/power functions interaction and development of appropriate control laws.

In the programmatic arena, some endorsement of a proposed lead-center approach to program management was received from the panel because of the number of disciplines involved and in order to capitalize on the strengths and expertise of the various interested organizations. Further contact with the European community in areas of common interest was also recommended. However, it was suggested that this be undertaken outside the technology workshop arena to avoid technology exchange questions that might arise.



**Page intentionally left blank**

INTEGRATED POWER/ATTITUDE CONTROL SYSTEM  
(IPACS)

C. R. Keckler  
NASA Langley Research Center  
Hampton, Virginia

## IPACS

IPACS is the acronym for a program conducted by the NASA Langley Research Center to examine the viability of combining the functions associated with spacecraft control and power into one system. This program developed the Integrated Power/Attitude Control System concept through in-house and contractual efforts which demonstrated the applicability of this system approach to Earth-orbital vehicles. The following material describes the development tasks and their major results.

# IPACS CONCEPT

The IPACS concept is illustrated in figure 1. During orbit day, solar energy collected by the solar cell arrays and transformed into electrical energy is used to power the spacecraft subsystems, including the control system represented by the gimbaled wheel at the right-hand side of the figure. In conventional spacecraft designs, a portion of the energy collected during the light portion of the orbit is stored in a set of batteries for use during orbit night. In the IPACS approach, that energy is stored in the rotating flywheel in the form of kinetic energy. Umbra electrical power demands are satisfied by attaching a generator to the wheel shaft and despinning the rotor. Through this approach, the battery system is no longer required and can thus be eliminated, as indicated by the cross-hatching on the figure.

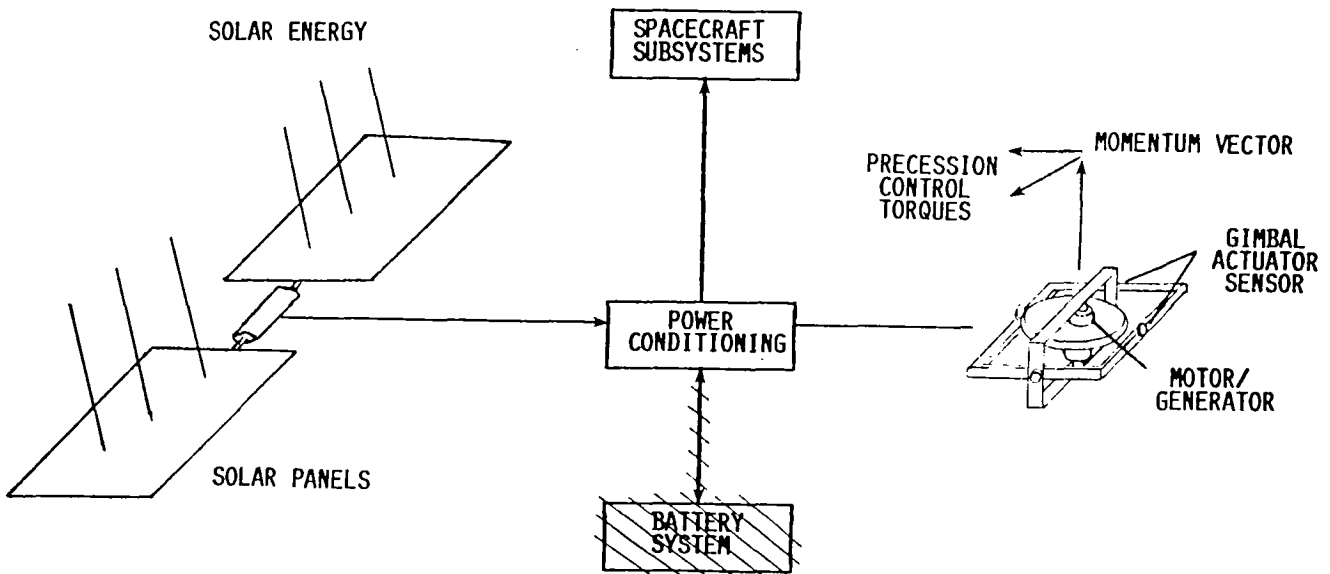

Figure 1

## MISSION APPLICATIONS STUDY

The applicability of this concept to a large variety of mission types and spacecraft sizes was examined to evaluate the system's versatility and competitiveness with regard to the proposed spacecraft designs. Six major missions were examined during this study (see figure 2). These included, in the extremes, a small low-Earth-orbit satellite and an interplanetary spacecraft, as well as a large manned space station. Power requirements for these missions ranged from 180 watts for the interplanetary vehicle during transit to 19 kilowatts for the modular space station. Control requirements span was from 1 arcsecond to 1 degree. Mission durations were postulated at 30 days to 10 years. In making the comparisons between the Phase-B designs and the IPACS concept, care was exercised to insure that comparable technologies were being considered. For example, for the modular space station, the IPACS concept incorporated the advanced technologies associated with magnetic suspension and composite material flywheels for comparison against regenerative fuel cells and control moment gyros of the Phase-B design. The results of this mission study indicated that the IPACS concept for satisfying the control and power requirements was applicable to all missions examined with the exception of the interplanetary flight because of its low power and control requirements during the long-term transit period.

	LAUNCH DATE	MISSION DURATION	MANNING	ORBIT CHARACTERISTICS KM/(NMI)	WEIGHT KG/(LB)	POINTING ACCURACY °DEGREES	POWER LEVEL WATTS	REMARKS
NEAR EARTH SATELLITE: EARTH OBSERVATIONS SATELLITE	1978	2 YRS	UNMANNED	SUN SYNCH 1100 (600)	770 (1700)	1.0	727W	EARTH OBSERV. SOLAR ARRAY/BATT
GEOSYNCHRONOUS SATELLITE: TRACKING & DATA RELAY SATELLITE	1977	3 YRS	UNMANNED	0° 35,700 (19,300)	1230 (2717)	0.9	300/180W	COMMUN. SAT. SOLAR ARRAY/BATT
PLANETARY SATELLITE: MARINER-JUPITER/SATURN	1977	4 YRS	UNMANNED	30° 1.43 x 10 <sup>8</sup> (9.5 A.U.)	680 (1500)	0.05	350W	SCIENTIFIC SAT. RTG
SHUTTLE 30-DAY MISSION: EARTH OBSERVATION & CONTA- MINATION TECHNOLOGY	1979	30 DAYS	MANNED	55° 500 (270)	97,500 (215,000)	0.5	3000W	EARTH RESOURCES FUEL CELL
RAM: ADVANCED SOLAR OBSERVATORY	1986	4-6 YRS	UNMANNED OPS. MANNED MAINTEN.	45 TO 55° 500 (270)	12,200 (27,000)	1 SEC	3400W	ASTRONOMY SOLAR ARRAY/BATT
MODULAR SPACE STATION: NORTH AMERICAN DESIGN	1985	10 YRS	MANNED	55° 500 (270)	81,500 (180,000)	0.25	19,000W	GENERAL PURPOSE SOLAR ARRAY/ REGEN F/C

Figure 2

## TRADE STUDY RESULTS

The results of the IPACS mission applications study are contained in references 1 and 2. It was shown in these references that significant benefits could be realized by using the IPACS concept in lieu of the more conventional Phase-B approaches. Benefits in terms of weight, volume, and cost savings were indicated for the missions studied and are summarized in figure 3. The interplanetary satellite was not carried through this evaluation since it had already been determined that it was not a viable application for the IPACS concept. As is seen in figure 3, the remaining five missions could expect to reap savings in at least two, and in most cases all three categories by using the IPACS concept over the Phase-B proposed approach.

MISSION	IPACS SAVINGS (%)		
	WEIGHT	VOLUME	COST
TDRS	10	- 67	27
RAM	31	80	18
MSS	16	87	22
SHUTTLE	6	84	- 5

Figure 3

## ADVANCED SOLAR OBSERVATORY MISSION

Having demonstrated the applicability of IPACS to a large variety of missions, it became necessary to select one candidate spacecraft for follow-on design efforts. The spacecraft selected for this task was the Advanced Solar Observatory associated with the Research and Applications Module (RAM) program. This vehicle, as shown in figure 4, is an unmanned free-flyer delivered to orbit by the Shuttle transportation system and periodically revisited for maintenance and resupply. This particular mission was selected because it posed the most stringent combined control and power requirements to the IPACS design of all those considered. As noted in figure 2, power levels of 3.4 kilowatts and a pointing accuracy of 1 arcsecond had to be provided to satisfy mission objectives. The design and fabrication of a laboratory model capable of meeting these requirements was thus undertaken as part of the technology enhancement effort.

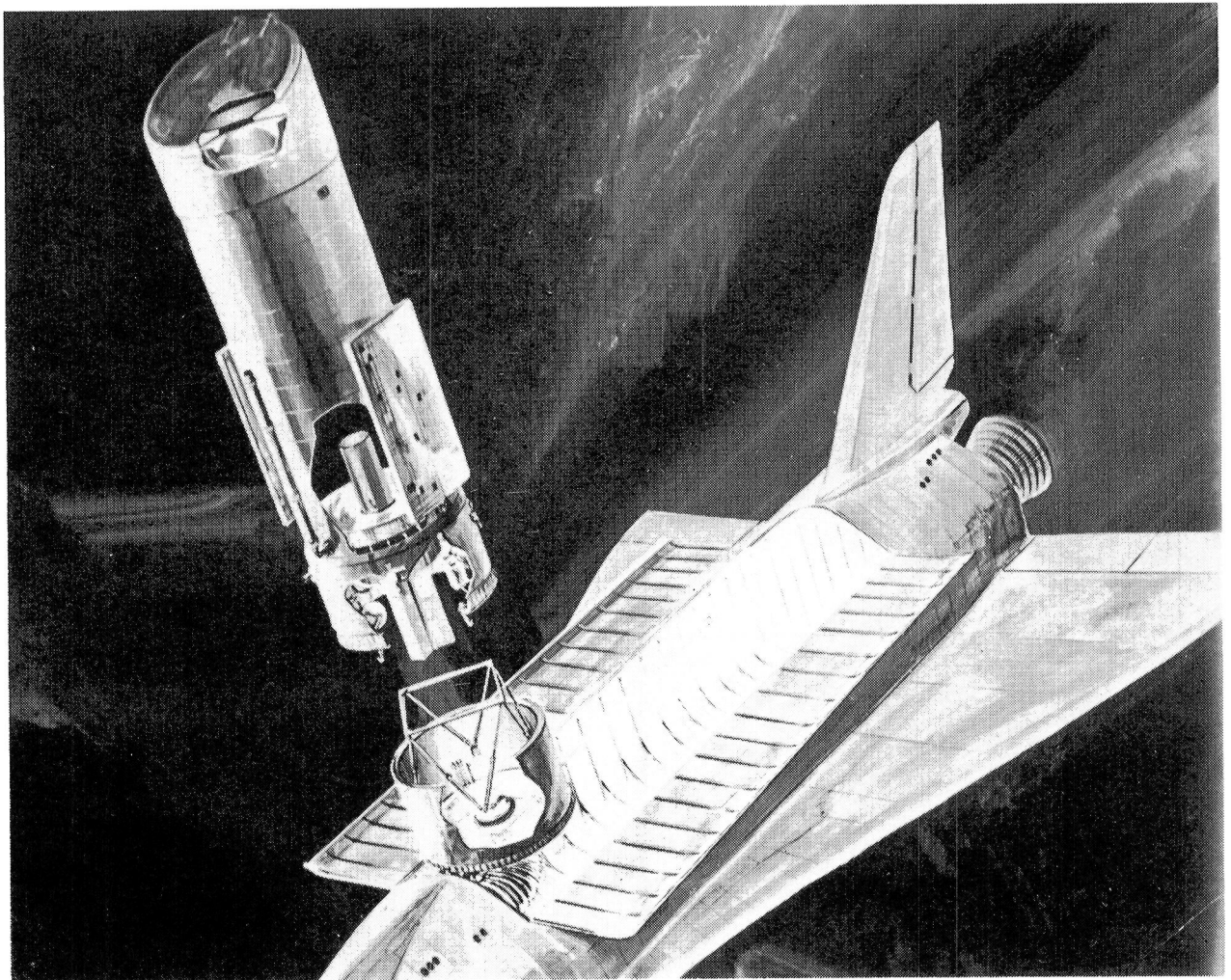

Figure 4

## SYSTEM SIMULATION SETUP

In parallel with the design and fabrication of laboratory hardware, a computer simulation, with hardware in the loop, of the candidate RAM mission of figure 4 was developed. The spacecraft dynamics, including the disturbance environment resulting from gravity gradient and aerodynamic torques, solar pressure, and experiment generated forces, were programmed on a hybrid computer shown in the top half of figure 5. Model control system hardware consisting of two double-gimbal control moment gyros (CMG's) was mounted in a torque measuring fixture (bottom half of figure 5), and linked to the hybrid computer. In addition to responding to gimbal commands issued by the computer, the CMG's were also operated in a manner representing energy storage and withdrawals by varying the speed of the two rotors. The torque measuring fixture monitored the torques resulting from gimbal motions and wheel speed variations and sent that information to the computer to close the simulation loop.

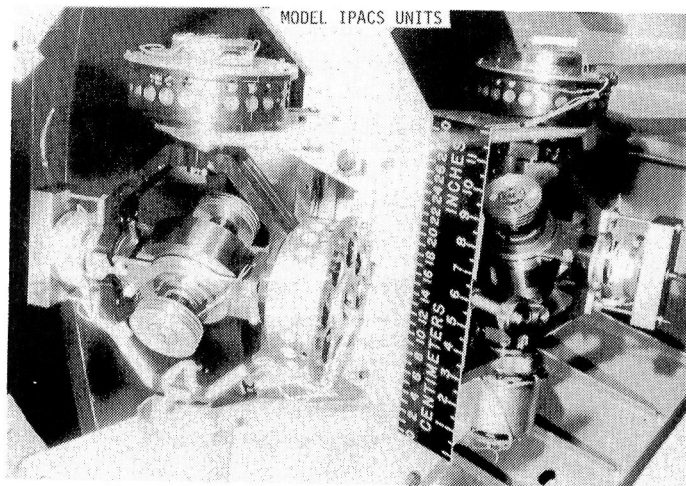
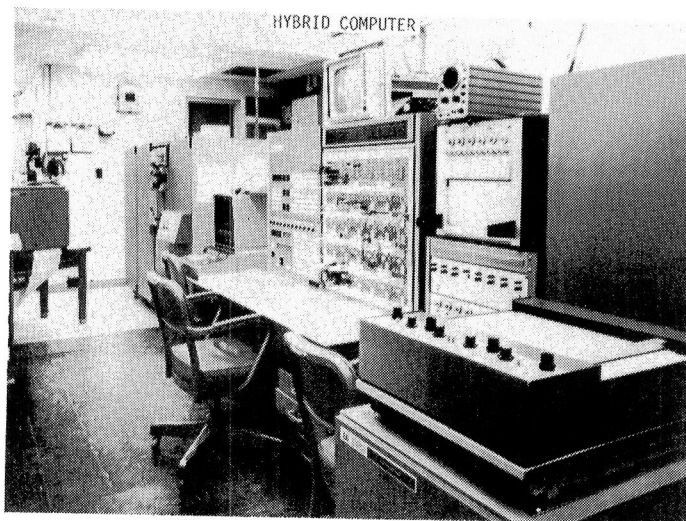

Figure 5



## SYSTEM RESPONSE WITH FULL MOMENTUM

The impact of combining the functions of two subsystems, i.e., power and control, into one integrated system on the pointing and stabilization of the spacecraft was examined with the aid of the computer simulation. Performance of the integrated system was examined at its full momentum and half momentum capacity, i.e., full and half wheel speed respectively. The results at full momentum capacity are displayed in figure 6. The spacecraft was subjected to orbital disturbances ( $T_D$ ), experiment generated disturbances ( $T_E$ ) resulting from telescope cover openings and camera operations, and torques produced by energy withdrawals ( $\dot{H}$ ). The momentum variation used in this case is representative of that caused by a steady power demand during the entire dark side of the orbit. In addition to compensating for these disturbances, the control system simultaneously effected a three-axis spacecraft maneuver. As can be seen, the pointing requirement of one arcsecond in the pitch ( $\phi$ ) and yaw ( $\psi$ ) axes was readily satisfied by this system even while accommodating the momentum variations resulting from power demands. These momentum changes are compensated for by moving the CMG gimbals.

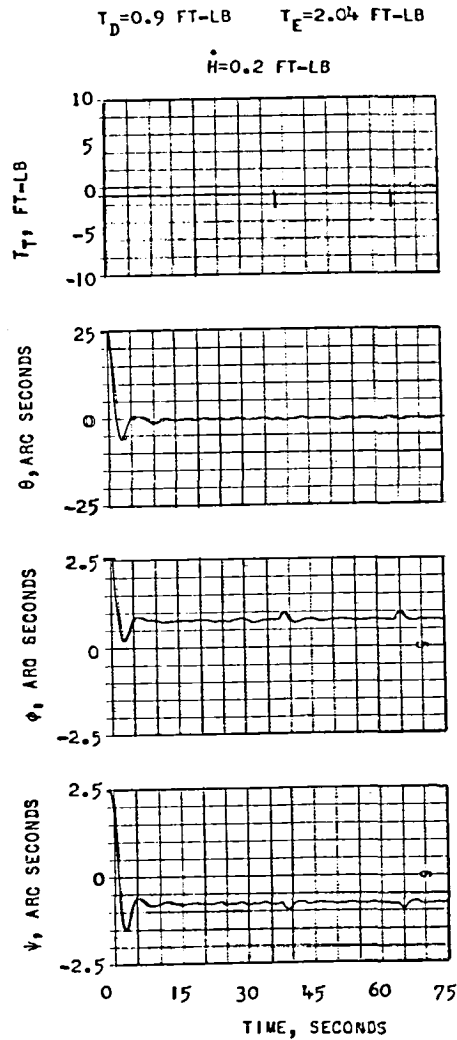

Figure 6

## SYSTEM RESPONSE WITH HALF MOMENTUM

The system's performance capability at half momentum, i.e., 50 percent wheel speed, is shown in figure 7. Again the spacecraft was subjected to the orbital and experiment disturbances ( $T_D$  and  $T_E$  respectively). The integrated power and control system was again required to compensate for these disturbances as well as for the momentum variations ( $\dot{H}$ ) resulting from energy state changes, while simultaneously effecting a three-axis vehicle maneuver. As can be readily noted, the one arcsecond pointing requirement was again easily satisfied. The system's performance while satisfying energy demands one order of magnitude higher than those used in figures 6 and 7 (i.e.,  $\dot{H} = 2 \text{ ft-lb}$ ) was also examined and found to be identical to that shown in those two figures.

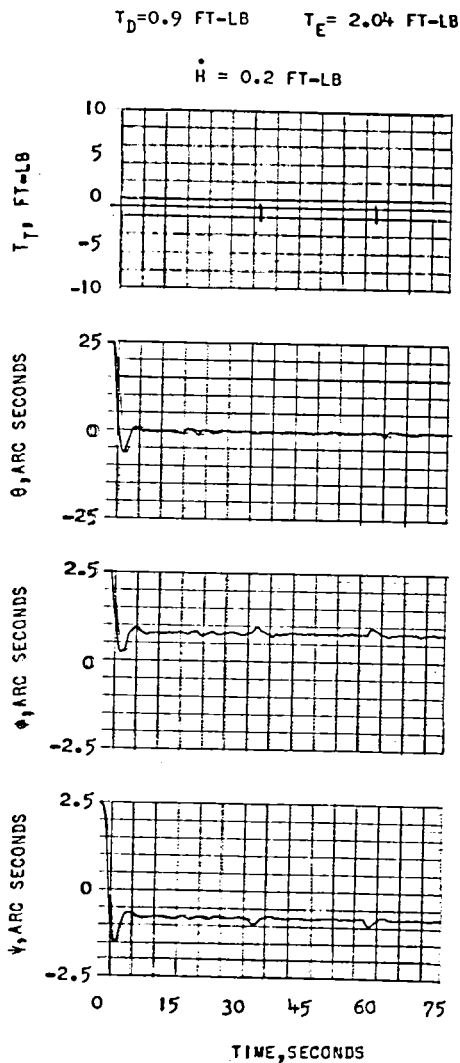

Figure 7

## IPACS LABORATORY HARDWARE

The laboratory hardware was designed to satisfy the requirements associated with the advanced solar observatory mission of figure 4. As such, each unit was required to provide a total energy storage capability of 1.5 kilowatt-hours and to deliver 2.5 kilowatts of power to the spacecraft's subsystems. Wheel speed variations of 50 percent were used to extract 75 percent of the stored energy. At half speed, each unit possessed a momentum capacity of about 1055 ft-lb-sec and a torque output of 20 ft-lbs. Figure 8 depicts the resulting hardware with the vacuum housing opened. The selected rotor shape is a constant stress design in order to maximize the realizable shape factor. This unit is 18 inches in diameter and fabricated out of titanium. A brushless d.c. motor/generator is attached to each end of the shaft to accelerate and decelerate the wheel as required by spacecraft energy requirements.

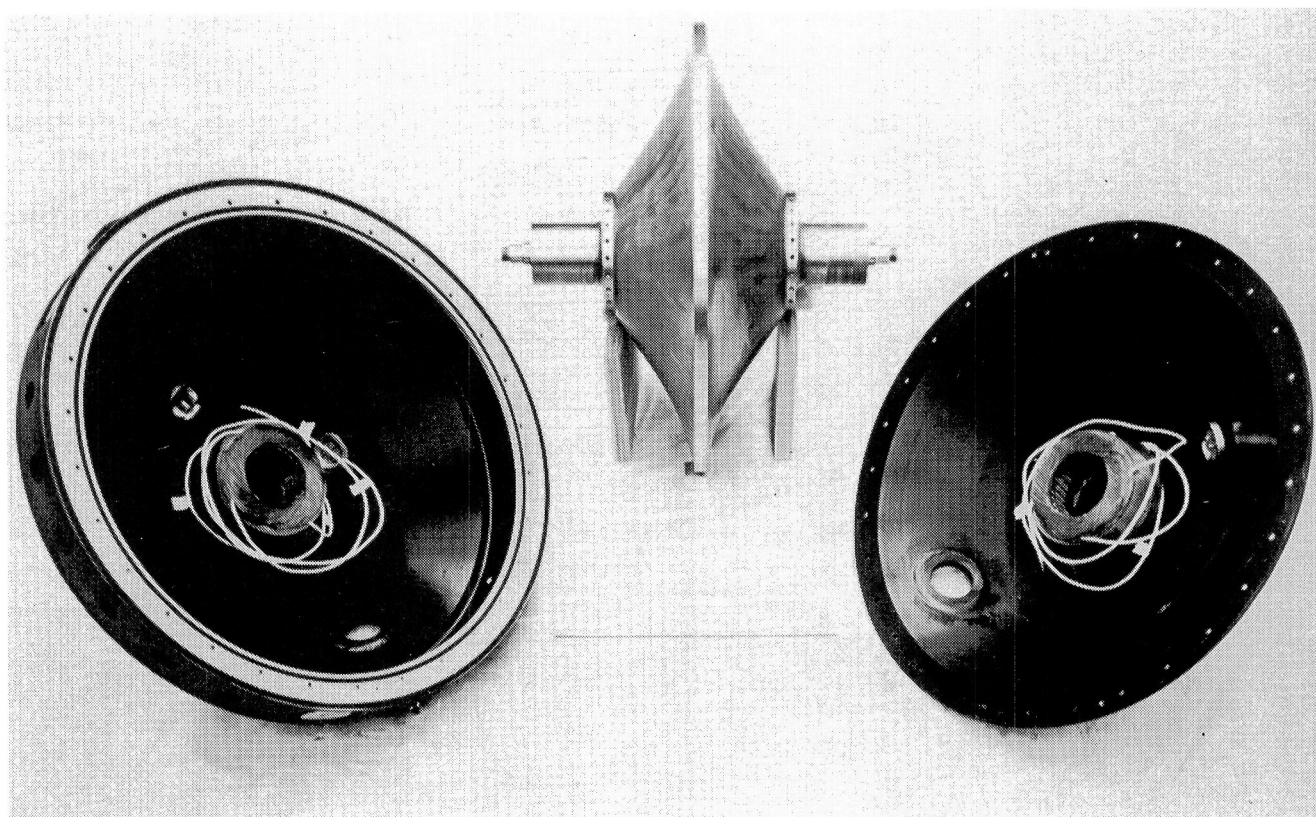

Figure 8

## IPACS ROTATING ASSEMBLY

The complete rotating assembly for the IPACS laboratory hardware is shown in figure 9. The unit shown here has a maximum dimension of 22.7 inches across the bearing housings, seen as cones on the right and left of the hardware. A vacuum housing is used to minimize windage losses on the rotor. A new set of electronics as well as a gimbal assembly complete with actuators and sensors is under development for this hardware. The entire assembly will be subjected to a thorough characterization program which will permit the mathematical modeling of the hardware for future use in system tradeoff studies.

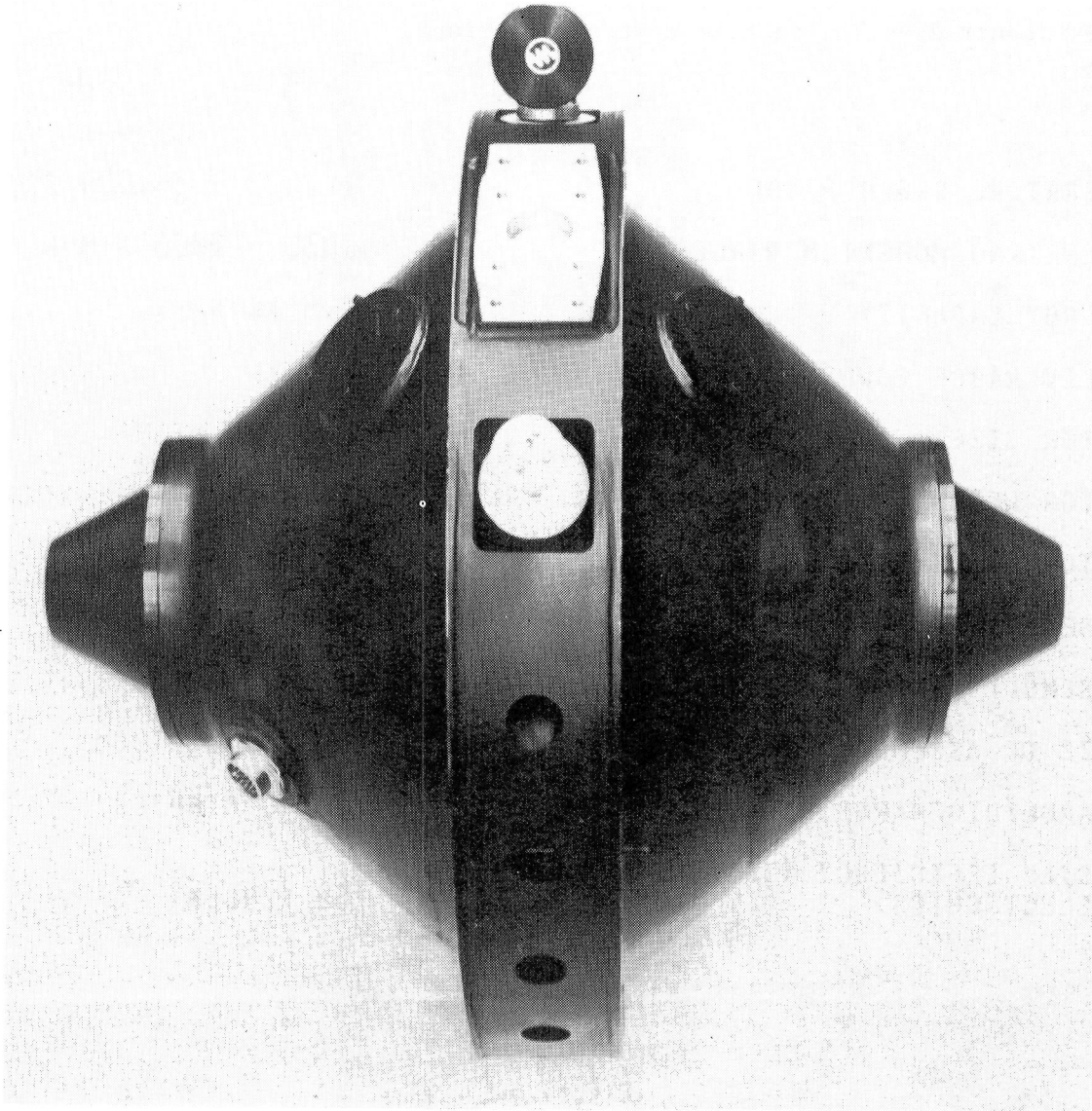

Figure 9

## IPACS HARDWARE CHARACTERISTICS

A detailed list of the laboratory unit's characteristics is included in figure 10. As seen, this unit has a rotor operating speed ranging from 17,500 to 35,000 rpm and is capable of storing 1.5 kilowatt-hours of energy. The rotor weighs 50.8 kilograms and possesses an energy density of 29.5 watt-hours/kilogram. The total assembly weight is 78.5 kilograms. The assembly energy density is 19.1 watt-hours/kilogram. The energy cycle for this device was based on a typical orbit time-line, with 50 minutes of daylight for charging or spinning up the rotor, and 40 minutes of darkness during which energy is withdrawn from the unit. The efficiency of this unit over the entire charge/discharge cycle, i.e., from the power bus to the power bus, has been measured at 52 percent with the majority of the losses occurring in the drive electronics. For control purposes, the momentum capacity of this assembly at the 17,500 rpm rotor speed is 1430 N-m-s which is more than twice the 680 N-m-s required by the vehicle control functions.

OPERATING SPEED RANGE	17,500 - 35,000 RPM
OPERATING MOMENTUM RANGE	1430 - 2860 N-M-S
ENERGY CAPACITY	1.5 KW-HR
DELIVERABLE POWER	2.5 KW
ROTOR SIZE	45.4 CM DIAM
ROTOR WEIGHT	50.8 KG
ROTOR ENERGY DENSITY	29.5 W-HR/KG
ASSEMBLY WEIGHT	78.5 KG
ASSEMBLY ENERGY DENSITY	19.1 W-HR/KG
SIZE OF ASSEMBLY	57.7 X 53.1 CM
CHARGE/DISCHARGE CYCLE DURATION	50/40 MINUTES
SYSTEM EFFICIENCY (INCLUDING ELECTRONICS)	52 PERCENT

Figure 10

## IPACS BENEFITS

The research performed on the IPACS concept has indicated that significant benefits can be realized in its utilization by a large variety of space missions. Among these benefits, as listed in figure 11, are reduced volume and weight. In addition, it has been determined that, unlike electrochemical energy storage systems, this concept is insensitive to depth of discharge or the number of charge-discharge cycles. This provides this system with long term operational life which can be further extended with inflight maintainability for compensation of system random failures. These capabilities result in reduced logistic support requirements and provide the mission managers with potential significant cost savings.

REDUCED VOLUME

REDUCED WEIGHT

LOW SENSITIVITY TO NUMBER OF CHARGE-DISCHARGE CYCLES

INSENSITIVE TO DEPTH OF DISCHARGE

LONG TERM OPERATIONAL LIFE

INFLIGHT MAINTAINABILITY

REDUCED LOGISTIC SUPPORT FOR REPAIR OR REPLACEMENT

REUSABILITY WITH MINIMUM REFURBISHMENT

REDUCED COST

Figure 11

## ADVANCED CMG

Research complementing the IPACS effort is being conducted on an advanced control moment gyro (CMG). A laboratory unit of this CMG, shown in figure 12, is undergoing evaluation at NASA LaRC. This unit has a momentum capacity of 4500 ft-lb-sec at approximately 6400 rpm, with an output torque capacity of 200 ft-lbs. To permit a high control bandwidth capability ( $\approx 15$  Hz) as well as to improve the momentum to mass ratio of such control hardware, a shell type of rotor has been incorporated into the rotating assembly. This rotor consists of a thick metal rim tied to a central shaft via two thin hemispherical shells. Conventional precision angular contact bearings are utilized in this assembly along with a brushless d.c. motor to accelerate the rotor to its operational speed.

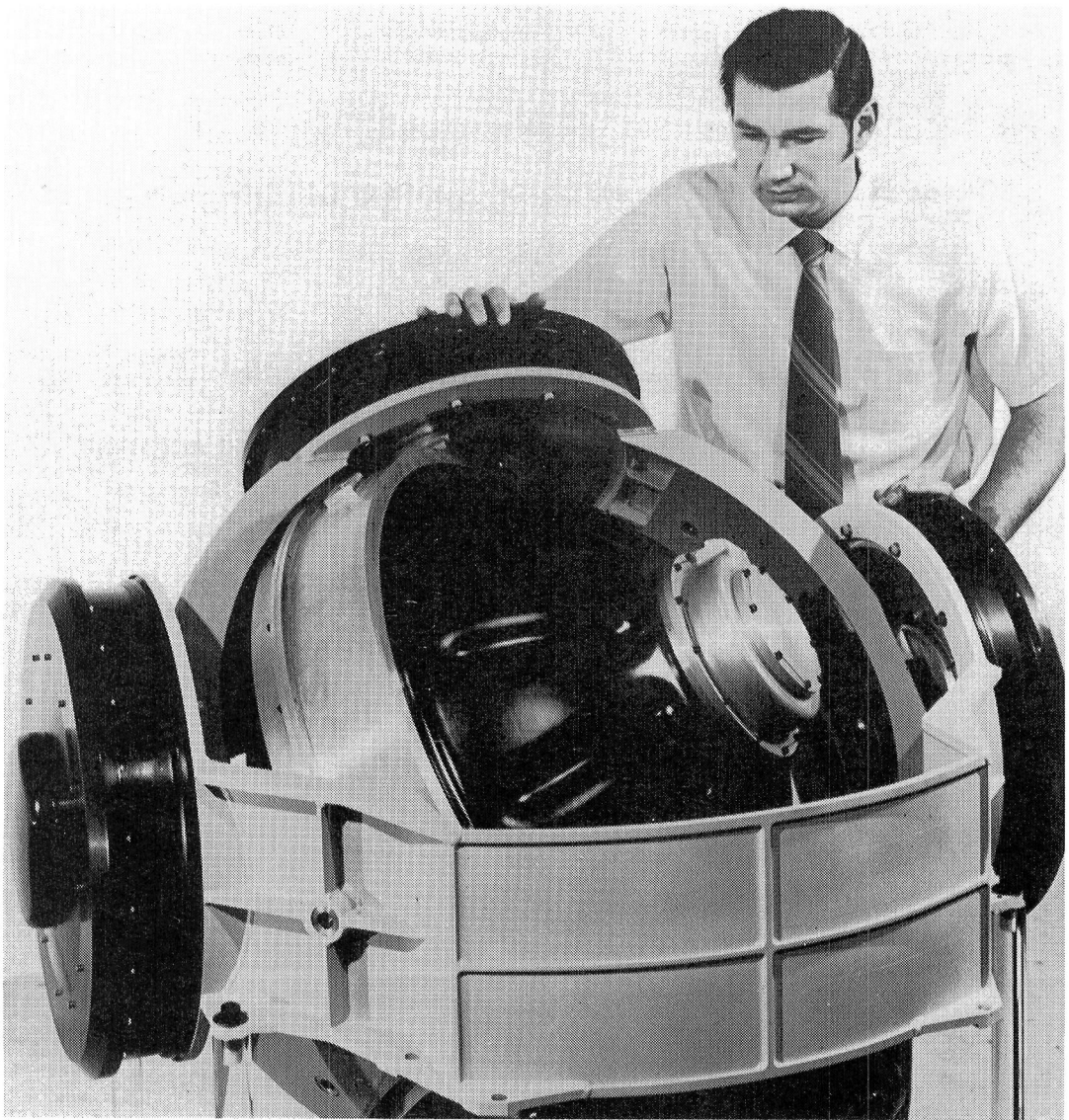

Figure 12



## DIRECT DRIVE TORQUER/SENSOR ASSEMBLY

The gimbals of the advanced CMG are driven by two direct-drive torquer/sensor assemblies per gimbal. Each torquer/sensor assembly has a torque output capacity of 100 ft-lbs. As shown in the drawing of figure 13, each assembly consists of a 100 ft-lbs brushless d.c. motor approximately 22 inches in diameter, a tachometer for gimbal rate measurement, a resolver for motor commutation and one for gimbal position information, and a slip ring assembly to permit the transfer of power and signals across the continuous rotation pivots of the gimbal structure. The total assembly has a diameter of 24 inches and weighs approximately 70 lbs.

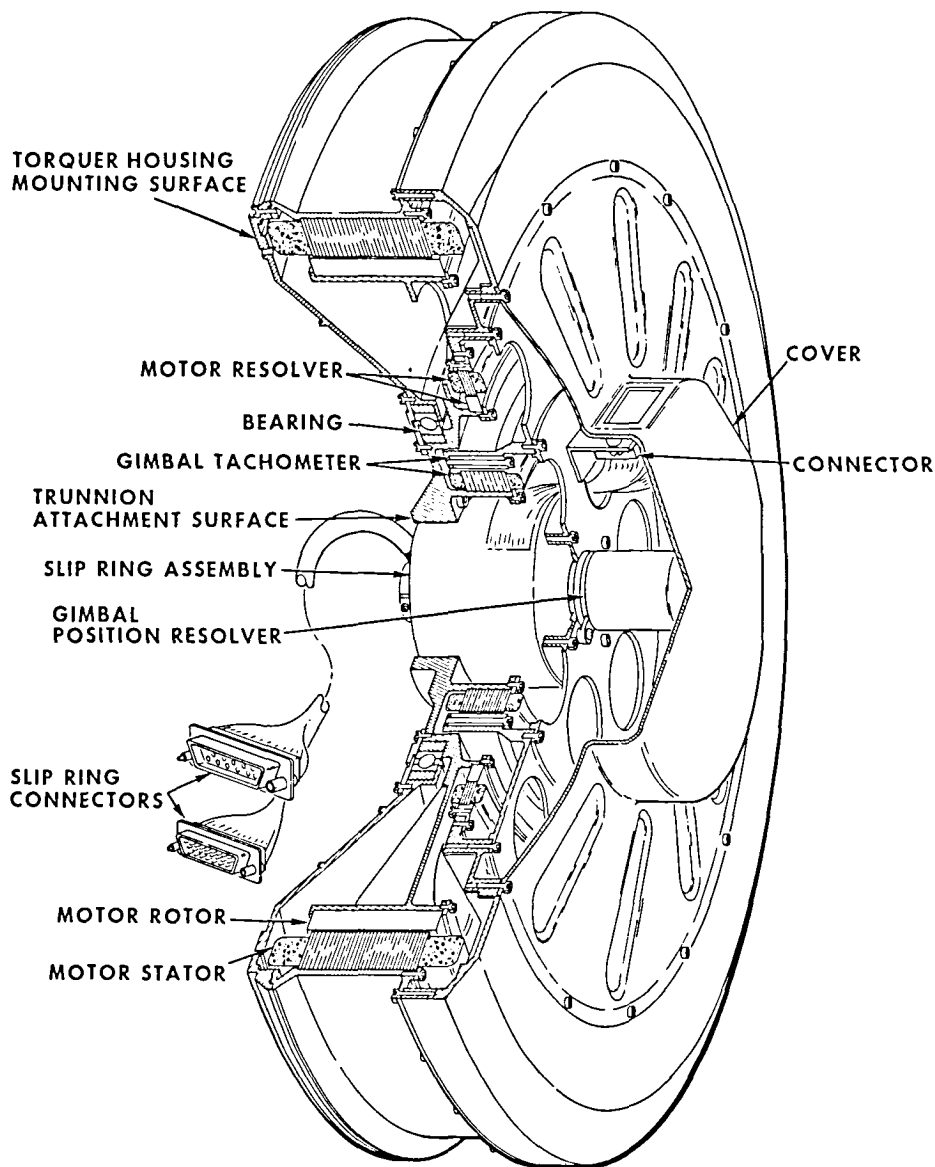

Figure 13



## LARGE CMG CHARACTERISTICS

The characteristics of the advanced CMG are presented in figure 14. In summary, this device has a momentum capacity of 4500 ft-lb-sec with a torque capability of 200 ft-lbs. It weighs approximately 630 lbs and has a physical envelope equal to the Skylab CMG flight units. The use of high stiffness elements throughout this assembly will permit a control bandwidth of about 15 hertz. This device, like the IPACS unit, will be subjected to a thorough characterization test program. The results of this effort will be used to generate high fidelity mathematical representation of this CMG for use in computer system studies and control system definitions.

### ROTATING ASSEMBLY

MOMENTUM CAPACITY	4500 FT-LB-SEC
WHEEL WEIGHT	170 LBS
H/M	852.4 FT <sup>2</sup> /SEC
IGA STIFFNESS	1.25 x 10 <sup>6</sup> FT-LB/RAD
STEADY-STATE POWER CONSUMPTION	57 W
DESIGN OPERATIONAL LIFE (NO MAINTENANCE)	20000 HRS

### OUTER GIMBAL

ENVELOPE	46 x 48 IN
STIFFNESS	4 x 10 <sup>6</sup> FT-LB/RAD
WEIGHT	85 LBS

### ACTUATOR (DIRECT DRIVE)

TORQUE OUTPUT	100 FT-LBS
POWER AT STALL	230 W
STIFFNESS	3 x 10 <sup>6</sup> FT-LB/RAD
WEIGHT	70 LBS

### TOTAL UNIT

MOMENTUM	4500 FT-LB-SEC
TORQUE	200 FT-LB
WEIGHT	630 LBS
VOLUME	33 CU-FT
CONTROL BANDWIDTH	≈ 15 Hz

Figure 14

## REFERENCES

1. Notti, J. E.; Cormack, A., III; and Schmill, W. C.: Integrated Power/Attitude Control System (IPACS) Study, Volume I - Feasibility Studies. NASA CR-2383, April 1974.
2. Notti, J. E.; Cormack, A., III; Schmill, W. C.; and Klein, W. J.: Integrated Power/Attitude Control System (IPACS) Study, Volume II - Conceptual Designs. NASA CR-2384, April 1974.

**Page intentionally left blank**

GSFC FLYWHEEL STATUS

G. E. Rodriguez  
NASA Goddard Space Flight Center  
Greenbelt, Maryland

The assessment of flywheel energy storage for spacecraft power systems at the Goddard Space Flight Center (GSFC) is based on the conceptual flywheel design as shown in figure 1. This conceptual design of an integrated flywheel is based on the "Mechanical Capacitor" (refs. 1 through 5) which evolved at the GSFC from development of magnetic bearings and permanent magnet ironless-brushless DC motors. The mechanical capacitor is based on three key technologies: (a) A composite rotor with a low ID to OD ratio for high energy density (weight and volume); (b) magnetic suspension close to the geometric center of the rotating mass to minimize loads normally encountered on the ends of a shaft, a no-wear mechanism in a vacuum environment, and to minimize losses at high rotational speeds; (c) permanent magnet ironless-brushless DC motor/generator for high efficiency of conversion and low losses at high rotational speeds. The complete system would include the necessary electronics for the motor/generator, containment, and counterrotating wheels for attitude control compatibility.

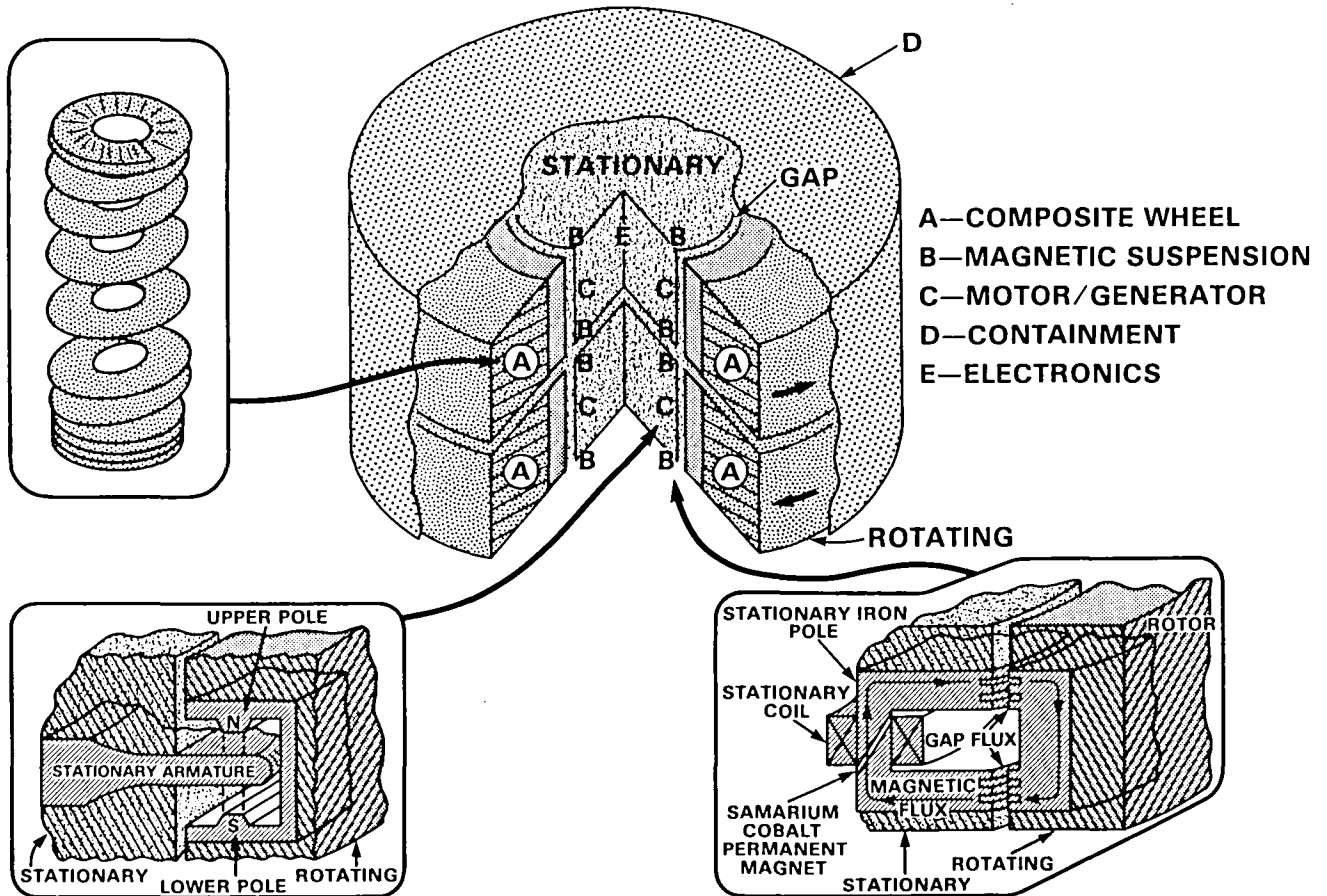

Figure 1.- Spacecraft flywheel power system: conceptual flywheel design.

The feasibility of inertial energy storage in a spacecraft power system with respect to power system configuration, power distribution, and spacecraft compatibility is not found to be dependent on the development of any technology other than the inertial energy storage element itself. The energy storage element under consideration (fig. 2) has potential advantages of long lifetime (20 to 30 years), high temperature (50°C) waste heat rejection, simple charge detection and control (wheel speed), inherent high voltage (>200 V) implementation (motor/generator design), high pulse power capability, higher energy density (Wh/kg) than NiCd, and higher volumetric density (Wh/m<sup>3</sup>) than NiH<sub>2</sub>. The relatively large momentum in inertial energy storage wheels must be precisely controlled to minimize attitude control disturbances or alternatively used to perform the attitude control functions with potential overall system mass savings. In either case, a direct interface is required with the ACS.

CHARACTERISTIC	MECHANISM
LONG LIFETIME.....30 YEARS	MAGNETIC SUSPENSION OF ROTATING MASS - NO WEAROUT MECHANISM
	DESIGN TO 10 <sup>5</sup> CYCLE FATIGUE STRESS
SIMPLE STATE-OF-CHARGE (SOC) MONITORING & CONTROL	WHEEL SPEED DETERMINES SOC
	CONTROL OF WHEEL SPEED CONTROLS SOC
ADAPTABLE VOLTAGE LEVEL IMPLEMENTATION	EASILY ACCOMMODATED BY PM M/G DESIGN
HIGH TEMPERATURE REJECTION OF WASTE HEAT	WASTE HEAT CONCENTRATED IN STATIONARY MASS - EASILY REMOVABLE BY CONDUCTION/RADIATION
±2% VOLTAGE REGULATION	PWM OF MOTOR CONTROL ELECTRONICS REQUIRED FOR DIFFERENTIAL SPEED CONTROL (A/C COMPATIBILITY)
PERFORM ATTITUDE CONTROL FUNCTIONS	INHERENT HIGH MOMENTUM BIAS IN WHEEL
MINIMIZE SYSTEM POWER PROCESSING COMPONENTS	SHUNT REGULATOR (±2% VOLTAGE REGULATION) IS ONLY POWER PROCESSING COMPONENT REQUIRED
HIGHER ENERGY DENSITY THAN NiCd	16 WHR/KG VERSUS 5-7 WHR/KG
HIGHER VOLUMETRIC DENSITY THAN Ni-H <sub>2</sub>	18 KWHR/M <sup>3</sup> VERSUS 7 KWHR/M <sup>3</sup>

Figure 2.- Potential advantages of inertial energy storage in spacecraft power systems.

The baseline design for a spacecraft power system configuration with inertial energy storage was defined in the initial studies to be a series type as shown in figure 3. The selected design is similar in configuration to the Multimission Modular Spacecraft/Modular Power System (MMS/MPS) (ref. 6) and allows a basis for comparison with an electrochemical based system (NiCd and NiH<sub>2</sub>). The configuration is typical of a system for Low Earth Orbit spacecraft, is sized for a payload capacity of 2.5 kW operational load, modular approach for growth up to 25 kW, employs a series element for peak power tracking of the array and utilizes a DC bus distribution voltage of 250 V. The storage element was initially sized as 2 counterrotating wheels with an energy storage capacity of 2.5 kW-hr each at maximum operational speed and a 50 percent depth of discharge (energy).

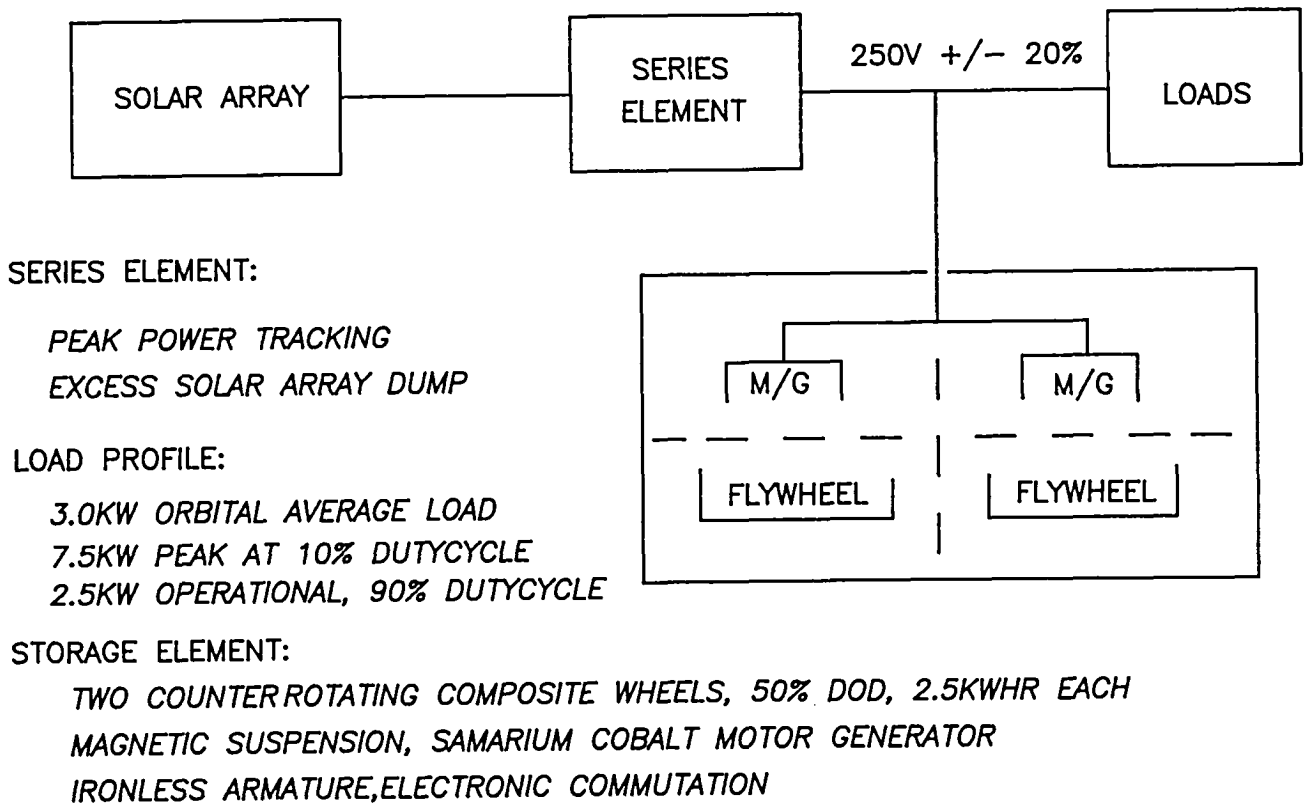

Figure 3.- Spacecraft flywheel power system: baseline definition.

Alternative power system configurations can be achieved with inertial energy storage that cannot be realized with electrochemical energy storage without the addition of external power conditioning components. For example, the Direct Energy Transfer (DET) system, or shunt configuration (fig. 4), can be achieved simply by pulsewidth modulation of the power switching components within the motor/generator to provide the charge/discharge regulator function normally provided by the additional power conditioning components shown in figure 4 for an electrochemical system (ref. 7). The shunt regulator function is still required in either case. The pulsewidth modulation of the power switching components does not significantly alter the net efficiency of the flywheel system. However, in the electrochemical system, a typical loss penalty of approximately 10 percent of the charge regulator and 10 percent for the discharge regulator is incurred, resulting in an overall loss of 20 percent.

COMPARISON FOR 3-kW, 250 -V<sub>DC</sub> SPACECRAFT POWER SYSTEM

		NiCd	NiH <sub>2</sub>	Inertial				
				50% <sup>a</sup>	75% <sup>b</sup>	75% <sup>c</sup>	75% <sup>d</sup>	75% <sup>e</sup>
Lifetime		5 yr 25% DOD	5 yr 40% DOD	20 yr based on 10 <sup>5</sup> cycles, 90 min LEO orbit				
Thermal Constraints		0° to 20°C	0° to 20°C	-25° to +50°C				
Launch Constraints		None	None	Wheels must be locked (vibration level)				
Compatibility ACS Struct.		No Interaction	No Interaction	Differential speed control of wheel speed required Unbalance causes vibration – unknown amount				
Voltage Regulation		±12%	±12%	±2%				
Energy Density Wh/kg		6.4	10	15.2	17.6	13	17.6	13
Energy/Volume kWh/m <sup>3</sup>		13	5.2	20	20	20	20	20
Charge Control		Complicated	Pressure sense may simplify detection and control	Wheel speed provides simple SOC detection and control method				
Weight Estimate in kg	Storage	326	202	137	118	160	118	160
	Solar	106	106	106	106	106	106	106
	Processing	20	20	20	20	20	7	7
	Total	352	328	263	244	286	231	273

<sup>a</sup>50% DOD, differential speed control, no containment

<sup>b</sup>75% DOD, differential speed control, no containment

<sup>c</sup>75% DOD, differential speed control, containment allowance

<sup>d</sup>75% DOD, differential speed control, no containment, shunt det

<sup>e</sup>75% DOD, differential speed control, containment allowance, shunt det

Figure 4.- Alternate power system configuration regulated bus (±2%) DET. (From ref. 7.)



A direct one-for-one comparison of a power system using inertial energy storage with a power system using electrochemical energy storage cannot be conducted because of the lack of a data base for inertial energy storage. However, a comparison of some form is necessary to highlight the advantage of one over the other. The comparison of inertial energy storage with electrochemical energy storage is shown in figure 5 for a spacecraft power system using available data of flight quality NiCd batteries, available NiH<sub>2</sub> battery data and generated "data" of the conceptual flywheel system of figure 1. A series power system configuration sized for 3 kW at 250 V DC is used as a baseline for comparison. Significant potential advantages of inertial energy storage are lifetime, thermal, voltage regulation, and state-of-charge detection and control.

ALTERNATE POWER SYSTEM CONFIGURATION

REGULATED BUS ( $\pm 2\%$ ) DET

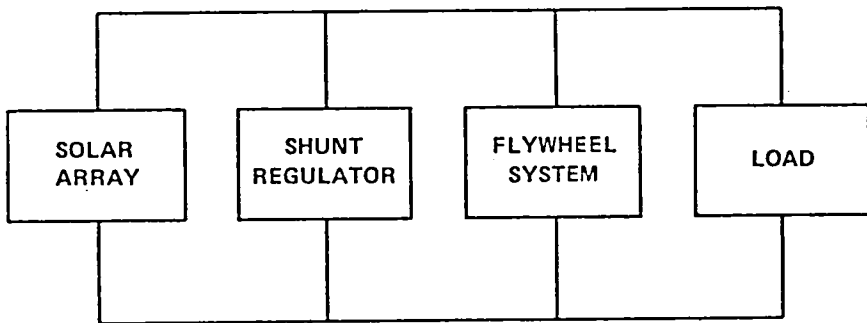

(a) Inertial energy storage.

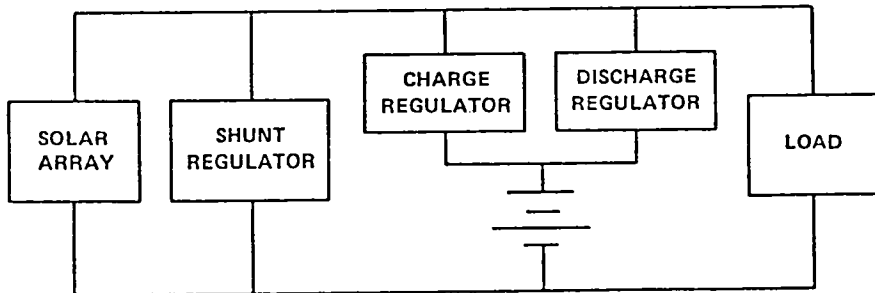

(b) Electrochemical storage.

Figure 5.- Comparison for 3-kW 250-V DC spacecraft power system. (From ref. 7.)

The potential advantages of inertial energy storage for spacecraft power systems depend on a successful design of an integrated flywheel system. Five critical technologies are identified in the successful development of this integrated flywheel system. These technologies are prioritized as a "thick rim" composite rotor with an ID/OD ratio of less than 0.6, magnetic suspension of the rotating mass close to its geometric center, a permanent magnet motor/generator integrated in the rotating and stationary mass, power electronics to interface between the spacecraft bus at 250 V DC and the motor/generator, and safe containment of the wheels in the event of wheel or system failure (fig. 6).

POTENTIAL ADVANTAGES OF INERTIAL ENERGY STORAGE FOR SPACECRAFT  
POWER SYSTEMS DEPEND ON SUCCESSFUL DESIGN OF AN INTEGRATED  
FLYWHEEL SYSTEM.

"THICK RIM" COMPOSITE ROTOR  
MAGNETIC SUSPENSION OF ROTATING MASS  
MOTOR/GENERATOR  
    PERMANENT MAGNET (INNER RADIUS OF WHEEL)  
    IRONLESS ARMATURE (STATIONARY)  
M/G CONTROL ELECTRONICS  
    COMMUTATION  
    SPEED CONTROL  
SAFE CONTAINMENT  
    FAILURE OF WHEEL  
    FAILURE OF OTHER ELEMENTS

Figure 6.- Summary of critical technologies.

Required energy storage level, energy density, wheel configuration, method of attachment and dynamic balance of composite wheel technology are compared with reported state-of-the-art technology in figure 7. The "required" parameters are based on the integrated flywheel system shown in figure 1.

<u>PARAMETER</u>	<u>REQUIREMENT</u>	<u>STATE OF THE ART</u>
ENERGY STORAGE	2.7 kW HR	1 kW HR
ENERGY DENSITY	50 WHR/KG AT 10 <sup>5</sup> CYCLES (15 YEARS)	50 WHR/KG AT 10 <sup>5</sup> CYCLES (DESIGNED, NOT DEMONSTRATED) 50 WHR/KG AT 10 <sup>3</sup> CYCLES (DEMONSTRATED) 88 WHR/KG BURST (DEMONSTRATED)
CONFIGURATION	TOROIDAL THICK RIM ID/OD < 0.6	AVCO SPIRAL WEAVE ID/OD=0.5 (NOT DEMONSTRATED) GE POLYURETHANE MATRIX ID/OD=0.2 (NOT DEMONSTRATED) GARRET AIRESEARCH ID/OD=0.8 (DEMONSTRATED)
ATTACHMENT	MAG. SUSPENSION AT INNER RADIUS TOP AND BOTTOM  PERMANENT MAGNET FOR MOTOR/GENERATOR AT INNER RADIUS CENTER	QUILL SHAFT WITH <u>ELASTOMER BOND</u> AT CENTER OF WHEEL NO HOLES
BALANCE	RESIDUAL MASS ECCENTRICITY < .113 μM*	3 TO 1348 μM** (ONLY SPOKE AND DISC WHEELS TESTED)

\*MEAN VALUE OF AMERICAN BALANCE PRACTICE FOR SPINNING MACHINERY

\*\*TEST RESULTS FROM OAK RIDGE FLYWHEEL EVALUATION LABS

Figure 7.- Critical technologies - energy storage wheel.

Magnetic suspension of energy storage wheels has been demonstrated and reported in the literature (e.g., ref. 1), but the unique application of magnetic suspension as shown in figure 1 requires low power consumption for a suspended mass of 37 kg at a peripheral speed of 330 m/sec, which represents an order of magnitude in speed of what has been demonstrated. The analytical tools for the design and analysis of magnetic suspension are limited. (See fig. 8.)

<u>PARAMETER</u>	<u>REQUIREMENTS</u>	<u>STATE OF THE ART</u>
POWER CONSUMPTION	16 WATTS SUSPENDED MASS OF 37 KG AT 330 M/SEC	8 WATTS SUSPENDED MASS OF 37 KG AT 33 M/SEC
NONLINEAR MAGNETIC FIELD ANALYSIS	STATIC & DYNAMIC	STATIC ONLY
DYNAMIC CONTROL STABILITY	NONLINEAR MAGNETIC AND MECHANICAL INTERACTIONS	LINEAR APPROXIMATIONS

Figure 8.- Critical technologies - magnetic suspension.

The motor/generator technology is well advanced, but the unique design of the integrated flywheel system requires extrapolation of available data to verify the rotational losses at the peripheral speeds of 330 m/sec. An efficiency of 92 percent for power conversion in the motor/generator electronics is assumed achievable at a bus voltage of 250 V DC, but requires demonstration. Similarly, bus voltage regulation/speed control must be demonstrated in either the motoring or generating mode. Successful containment of the wheel is a technology which the Department of Energy recently started. Mass penalties of 25 to 150 percent of the rotating mass have been estimated as achievable, but remain to be demonstrated. (See fig. 9.)

<u>TECHNOLOGY</u>	<u>PARAMETER</u>	<u>REQUIREMENT</u>	<u>STATE-OF-THE-ART</u>
III. MOTOR/GEN (M/G)	POWER EFFICIENCY	> 95%	ACHIEVABLE
	ROTATIONAL LOSSES (NO LOAD)	20 WATTS AT 330 M/SEC	REQUIRES EXTRAPOLATION
	POWER DENSITY	2500 WATTS/KG AT 32 KRPM	1650 W/KG AT 32 KRPM
IV. M/G ELECTRONICS	POWER EFFICIENCY	> 92%	ACHIEVABLE
	POWER CONSUMPTION OPERATION	4 WATTS PERFORM TRI- FUNCTION OF COMMUTATION/ SPEED CONTROL/ BUS REGULATION IN EITHER MOTORING OR GENERATING MODE	ACHIEVABLE COMMUTATION/SPEED CONTROL (PARTLY DEMONSTRATED - MOTOR) BUS REGULATION (NOT DEMONSTRATED)
V. CONTAINMENT	MASS	50% OF ROTATING MASS	25% TO 150% (DOE AND GE ESTIMATES)

Figure 9.- Remaining critical technologies.

The tentative program plan at the GSFC is based on restrained resources (funding limitations). The program is geared toward the development/verification of a single composite rotor exhibiting the desired characteristics for an integrated fly-wheel system. If the rotor is proven successful, the program would continue with the development of the magnetic suspension, motor generator and electronics. A proof-of-principle module would be the end item, and the schedule is as shown in figure 10.

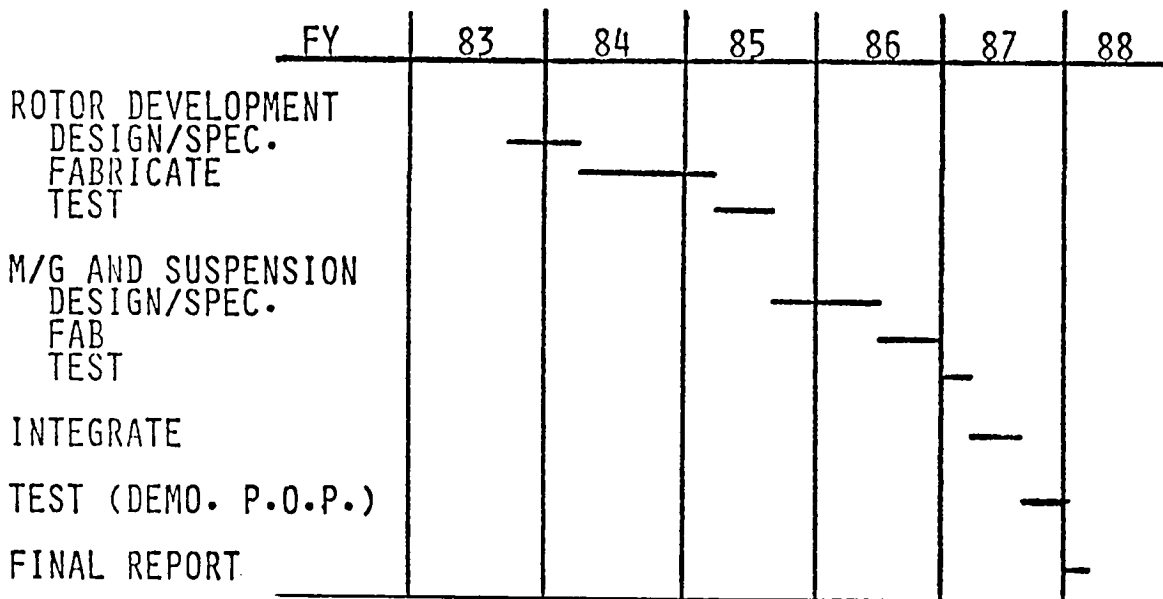

Figure 10.- GSFC program plan - inertial energy storage (constrained resources).

## REFERENCES

1. Kirk, J. A.; Studer, P. A.; and Evans, H. E.: Mechanical Capacitor. NASA TN D-8185, 1975.
2. Michaelis, T. D.; Schlieben, E. W.; and Scott, R. D.: Design Definition of a Mechanical Capacitor. NASA CR-152613, 1977.
3. Scott, R. D.: Mechanical Capacitor Energy Storage System. NASA CR-170613, 1978.
4. Kirk, James A.: Flywheel Energy Storage-I Basic Concepts. Int. J. Mech. Sci., vol. 19, Jan. 1977, pp. 223-231.
5. Kirk, James A.: Flywheel Energy Storage-II Magnetically Suspended Super Flywheel. Int. J. Mech. Sci., vol. 19, Jan. 1977, pp. 233-245.
6. Harris, D. W.: The Modular Power Subsystem for the Multimission Modular Spacecraft. Proceedings 13th IECEC, vol. 1, no. 789003, Aug. 1978.
7. Rodriguez, G. E.; Studer, P. A.; and Baer, D. A.: Assessment of Flywheel Energy Storage for Spacecraft Power Systems. NASA TM-85061, 1983.

OVERVIEW OF STATE-OF-THE-ART  
FLYWHEEL TECHNOLOGY

Mitchell Olszewski  
Oak Ridge National Laboratory  
Oak Ridge, Tennessee 37830



The technology and applications evaluation task focuses on defining performance and cost requirements for flywheels in the various areas of application. To date the DOE program has focused on automotive applications. The composite materials effort entails the testing of new commercial composites to determine their engineering properties. The rotor and containment development work uses data from these program elements to design and fabricate flywheels. The flywheels are then tested at the Oak Ridge Flywheel Evaluation Laboratory and their performance is evaluated to indicate possible areas for improvement. Once a rotor has been fully developed it is transferred to the private sector.

## THE FIVE COMPONENTS OF FLYWHEEL DEVELOPMENT EFFORT ARE INTERACTIVE

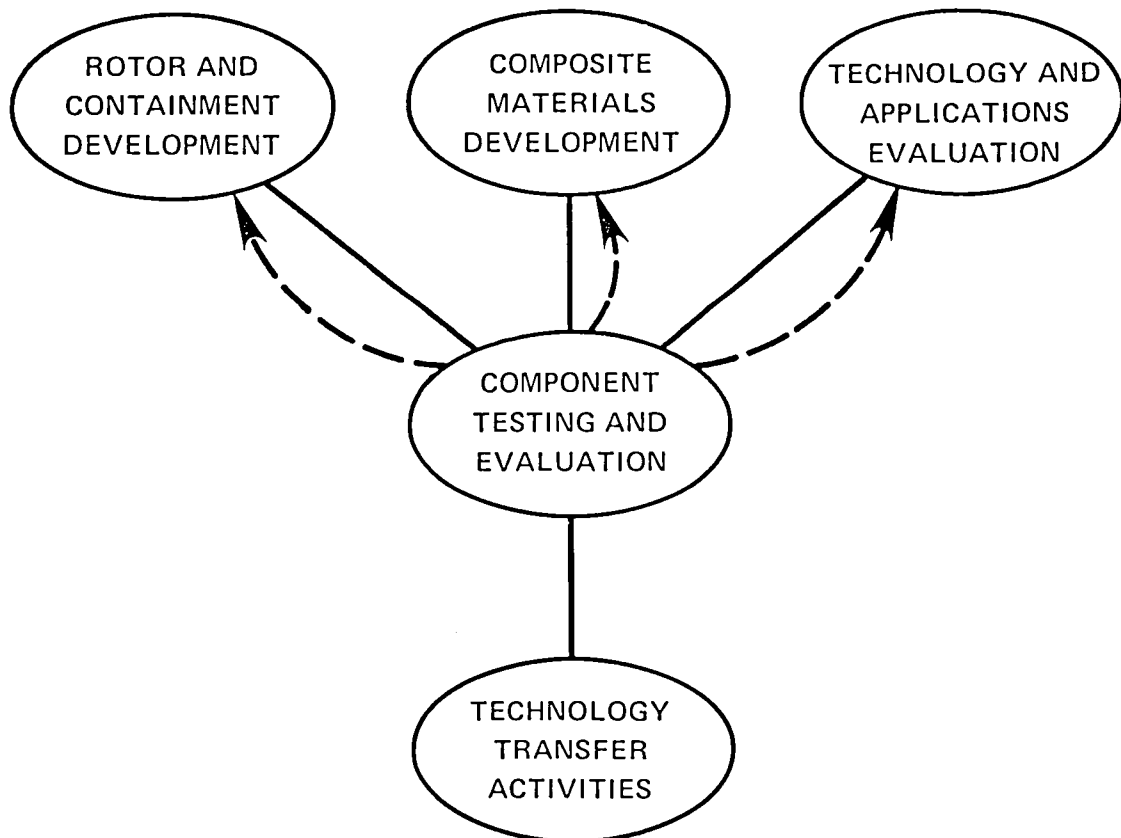

The Oak Ridge National Laboratory is the lead center for the DOE flywheel effort. This includes program management functions as well as technical development in the area of testing. Fabricated rotors are supplied by the private sector. This is done to ease technology transfer once developmental activities have been completed.

## THE MEST PROGRAM HAS INVOLVED PUBLIC AND PRIVATE SECTOR PARTICIPATION

- ORNL
  - MANAGES AND DIRECTS PROGRAM
  - TESTING OF FLYWHEELS IN OAK RIDGE FLYWHEEL EVALUATION LABORATORY (ORFEL)
  - DEVELOPMENT OF ADVANCED TESTING TECHNIQUES TO OBTAIN MORE COMPLETE DATA FROM TESTS
  - DEVELOPMENT OF NONDESTRUCTIVE INSPECTION TO PREDICT INCIPIENT FAILURE
  
- LLNL
  - ROTOR TEST DATA ANALYSIS EFFORTS
  - ENGINEERING DATA FOR NEW COMPOSITES
  
- PRIVATE SECTOR PARTICIPANTS SUPPLIED ROTORS
  - GENERAL ELECTRIC
  - GARRETT AIRESEARCH
  - AVCO
  - BROBECK
  - OWENS CORNING/LORD KINEMATICS

Over the past several years energy storage densities (defined as the amount of energy stored by the wheel at its ultimate speed) have increased rapidly for composite flywheels. At the present time composite flywheels have higher storage densities than metallic rotors. In the future it is expected that with advanced materials now available and new designs an order of magnitude increase in storage density will occur.

## ENERGY STORAGE DENSITY HAS INCREASED RAPIDLY FOR COMPOSITE MATERIALS AND CAN LIKELY MAKE FURTHER RAPID PROGRESS

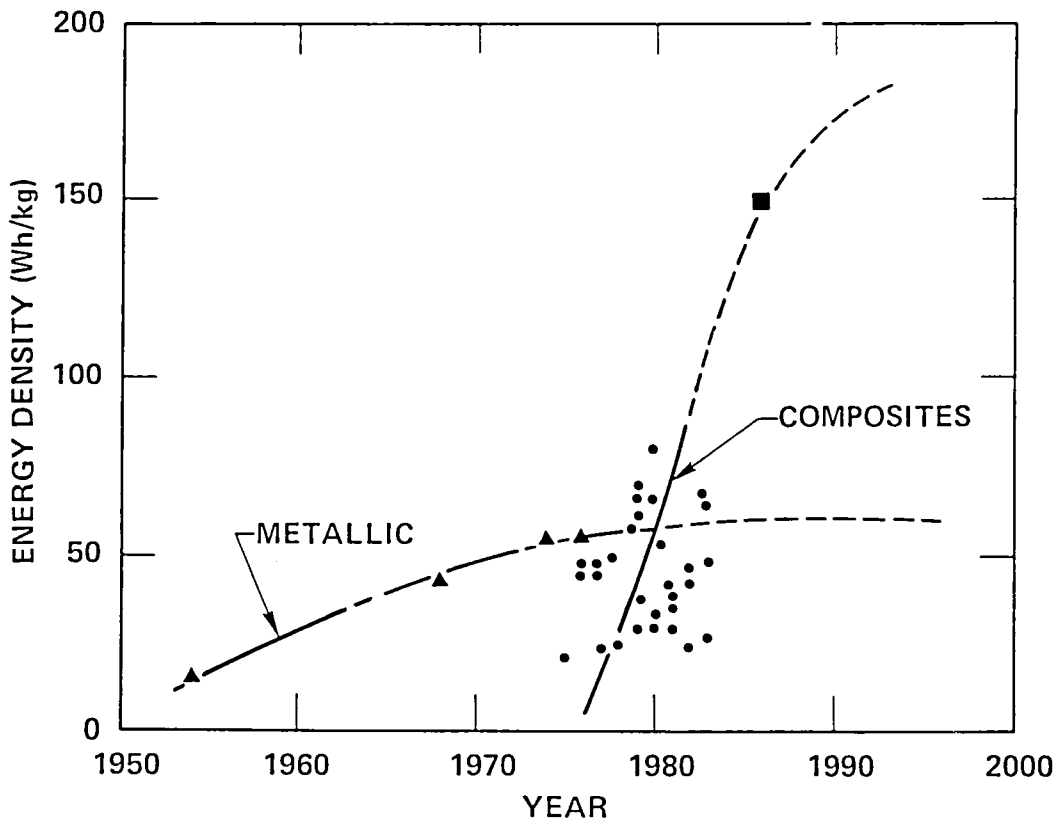

Three rotors were chosen for second generation testing activities. The disk/ring design uses an SMC  $\alpha$ -ply layup disk with a wound graphite/epoxy ring. The subcircular rim wheel is composed of a 9 or 15 ring rim using a Kevlar/epoxy material with a graphite spoke system. The bidirectional weave wheel uses a fabric of fibers in a helically wound configuration. After layup the fabric is impregnated with resin.

## ROTOR AND CONTAINMENT DEVELOPMENT ACTIVITIES INCLUDE

- DESIGN SPECIFICATIONS FOR ROTORS
  - PRESENT ROTOR DESIGNS SELECTED FOR EVALUATION INCLUDE
    - HYBRID DISK/RING
    - SUBCIRCULAR RIM
    - BIDIRECTIONAL WEAVE
- DESIGN DATA FOR ROTOR/HUB ELASTOMERIC BOND
- COST ANALYSIS

The first generation wheels concentrated on rim and disk type designs. A variety of materials were used and the performance of the wheels varied greatly. The highest energy density obtained was 79.5 Wh/kg using a rim design.

## FIRST GENERATION ROTORS SHOWED A WIDE VARIATION IN PERFORMANCE

<u>MANUFACTURER</u>	<u>WHEEL TYPE</u>	<u>MATERIAL</u>	<u>BURST ENERGY (Wh/kg)</u>
BROBECK	RIM	SG/K49	63.7
GARRETT/ AiRESEARCH	RIM	K49/K29/SG	79.5
ROCKETDYNE	OVERWRAP RIM	G	36.1
APL-METGLASS	RIM	M	24.4
HERCULES	DISK (CONTOURED PIERCED)	G	37.4
AVCO	DISK (PIERCED)	SG	44.0
LLNL	DISK (TAPERED)	G	62.6
LLNL	DISK (FLAT)	SG	67.1
GE	DISK (SOLID)	SG/G	55.1
OWENS/LORD	DISK	SMG/G	27.8
		SMC/G	36.6
		SMC/G	25.0
		SMC	17.5

---

SG = S GLASS; K49 = KEVLAR 49, K29 = KEVLAR 29; G = GRAPHITE; M = METGLASS;  
SMC = S-GLASS SHEET MOLDING COMPOUND

During FY 1983 the advanced design wheels were tested. The disk and disk/ring designs successfully completed 10,000 cycle fatigue tests. Subsequent ultimate speed tests indicated energy densities higher than that achieved by similar wheels that had not been fatigued. The sub-circular rim design wheel did not successfully complete the cyclic fatigue test, failing at 2585 cycles. In addition, energy storage densities at ultimate speed were 26% below design specifications. The bidirectional weave design showed a very low energy storage density. This very low value is likely attributable to poor resin impregnation during fabrication.

## ROTORS OF IMPROVED DESIGN HAVE UNDERGONE CYCLIC FATIGUE AND ULTIMATE SPEED TESTS

- DISK AND HYBRID DISK/RING DESIGNS
  - BOTH SUCCESSFULLY COMPLETED 10,000 CYCLE FATIGUE TESTS
  - BURST ENERGY DENSITIES SHOWED NO DECLINE
    - DISK 48.6 Wh/kg
    - HYBRID 63.5 Wh/kg
  
- SUB-CIRCULAR RIM
  - FAILURE IN CYCLIC TEST OCCURRED AT 2585 CYCLES
  - ULTIMATE SPEED TEST RESULT 65.4 Wh/kg BELOW DESIGN EXPECTATION OF 88 Wh/kg
  - SUBCIRCULAR RIM MAY PUT COMPRESSION LOAD ON FIBERS THAT SIGNIFICANTLY WEAKENS THEM
  
- BIDIRECTIONAL WEAVE
  - PATTERNED TO IMPROVE RADIAL STRENGTH
  - BURST TEST DENSITY 37.3 Wh/kg WAS LOW
  - FAILURE DUE TO DELAMINATION PROBABLY RESULT OF POOR RESIN IMPREGNATION

With cost constraints loosened (as opposed to automotive applications), a 2% strain graphite fiber becomes a very attractive candidate for space flywheel systems. Its ultimate tensile strength of 700 ksi or greater would make possible much higher energy densities. Use of this fiber with a flexible resin would permit the fabrication and operation of a thick rim design having an ID/OD ratio of 0.5 or less. This design could yield energy storage densities of 150 Wh/kg or greater.

## ADVANCED FIBERS COULD SIGNIFICANTLY INCREASE STORAGE DENSITIES

- THE 2% STRAIN GRAPHITE FIBER DEVELOPED BY HERCULES PROMISES TO GIVE A 700 ksi ULTIMATE TENSILE STRENGTH
- IT HAS NOT BEEN INVESTIGATED FOR TERRESTRIAL APPLICATIONS BECAUSE AT \$30/lb IT IS TOO COSTLY
- FOR MILITARY APPLICATIONS, WHERE SPACE OR WEIGHT ARE AT A PREMIUM, THE MATERIAL RELATED STORAGE COST OF \$88/kWh IS NOT UNREASONABLE
- WE ESTIMATE THAT USE OF THE 2% STRAIN GRAPHITE IN THE HYBRID DISK/RING DESIGN COULD RESULT IN AN ENERGY DENSITY OF 150 Wh/kg

Spin testing of flywheels is a very important component of the DOE program. The testing program is designed to confirm failure modes of the flywheel as well as determine how a material performs in a specific design.

## SPIN TESTING IS A CRITICAL COMPONENT OF FLYWHEEL DEVELOPMENT

- CONFIRM MATERIAL PERFORMANCE AS USED IN A SPECIFIC DESIGN
- CONFIRM FAILURE MODE
- GENERATE DATA CONCERNING EFFECTS OF CYCLING ON WHEEL
  - FATIGUE
  - RELAXATION
- LOOK FOR CRITICAL RESONANCES IN DESIGN



The Oak Ridge Flywheel Evaluation Laboratory represents the state of the art for spin testing flywheels. High speed balancing before the test insures that material limits will be reached during the test. Radial runouts of the arbor, hub, and wheel are monitored continuously during the test and can be used to indicate if something is going wrong with the flywheel during the test. Other parameters measured during the test include flywheel temperature, axial runout, and vacuum.

## THE ORFEL FACILITY OFFERS UNIQUE INSTRUMENTATION AND DATA ANALYSIS CAPABILITIES NOT AVAILABLE IN OTHER FACILITIES

- BEFORE TEST ACTIVITIES INCLUDE
  - HIGH SPEED (UP TO 30,000 rpm) BALANCING
  - COMPUTATION OF WHIRL FREQUENCIES
  - DETERMINATION OF FORCE RESONANCE FREQUENCY
  
- DURING THE TEST THE FOLLOWING PARAMETERS ARE MONITORED
  - FLYWHEEL TEMPERATURE VIA PYROMETRY
  - RADIAL RUNOUT OF ARBOR, HUB AND WHEEL
  - AXIAL RUNOUT TO DETERMINE TILT OF WHEEL
  - VACUUM
  
- CRITICAL PARAMETERS SUCH AS WHIRL AND FORCED RESONANCE ARE ALSO ANALYZED DURING THE TEST USING AN ON-LINE COMPUTER AND FREQUENCY SPECTRUM ANALYZER

It would be useful if a technique was available to predict incipient failure of the flywheel while in service. To this end ORNL has begun investigations concerning non-contact strain measurement and nondestructive inspection. These techniques show promise but have not been developed to the point where they are a useful diagnostic tool.

## PRELIMINARY INVESTIGATIONS HAVE BEEN MADE FOR OTHER MEASUREMENT TECHNIQUES

- NON-CONTACT STRAIN MEASUREMENT
  - USES CHANGE IN DIFFRACTION ANGLE OF A LASER-ILLUMINATED DIFFRACTION GRATING, BONDED TO FLYWHEEL AS INDICATOR OF STRAIN
  - COMMERCIAL GRATINGS (14,000 LINE/INCH) YIELDED RESOLUTIONS NOT ADEQUATE FOR THE LOW STRAIN (~ 0.7%) MATERIALS USED
  - RESOLUTION MAY BE ADEQUATE FOR 2% STRAIN MATERIAL
  
- NDI
  - ULTRASONIC DETECTION OF MICROCRACKING IN THE MATRIX
  - PRELIMINARY RESULTS SHOWED FREQUENCY ATTENUATION INCREASES MONOTONICALLY WITH STRAIN HISTORY
  - NOT YET ABLE TO USE TECHNIQUE TO PREDICT INCIPIENT FAILURE

**Page intentionally left blank**

EUROPEAN INTEGRATED FLYWHEEL TECHNOLOGY

J.B. Dahlgren  
Office of Aeronautics and Space Technology  
NASA Headquarters  
Washington, D.C.

## EUROPEAN INTEGRATED FLYWHEEL TECHNOLOGY

NASA began developing the Integrated Power/Attitude Control System (IPACS) over ten years ago, along with magnetic bearing technology for use in rotating machines. The Europeans began intensifying their efforts in related areas in the mid 1970's and have possibly moved ahead of the US in specific component areas. The Europeans have pursued Integrated Energy Storage and Attitude Control Systems (IEAS) in studies and developments for the past five years (Fig. 1.). Their studies have indicated that the use of integrated power and control flywheels for high power in future European satellite applications will yield benefits. In related technology areas it was learned during the European Space Agency (ESA) contractor visits in May 1982 that NASA personnel were extremely impressed by the apparent commitments ESA had made to integrate magnetic suspension technology in all types of rotating devices. It was learned that 5 companies have competing designs for magnetic bearing reaction wheels, and that one wheel has been in continuous life test 4 years. In addition they have existing wheels in the 10-20 Nm class which can store  $1/2 \text{ KW-HR/FT}^3$ , and new composite wheels in development which can store  $2 \text{ KW-HR/FT}^3$  when run at 20,000 RPM.

Last fall it was reported that Aerospatiale is working advanced concepts for a wheel energy storage system for satellite power conditioning and attitude control wherein the wheel would turn at 33,000 rpm, offer 10-15 year lifetime (i.e., implying the use of magnetic suspension), and offer higher efficiency than can be achieved with batteries. This latter system is planned for use on the SPOT earth resources satellite scheduled for launch in 1984. Aerospatiale has also expressed interest in a cooperative program with the US in the IEAS concept.

- o EUROPEAN STUDIES INDICATED THAT INTEGRATED POWER & CONTROL WILL YIELD BENEFITS. EUROPEANS INVOLVED LAST 5 YEARS.
- o ESA CONTRACTOR VISITS IN MAY 82
  - o 5 COMPANIES HAVE COMPETING DESIGNS FOR MAGNETIC BEARING REACTION WHEELS
  - o 1 WHEEL IN LIFE TEST 4 YEARS
  - o EXISTING WHEELS IN 10-20 NM CLASS CAN STORE  $1/2 \text{ KW-HR/FT}^3$
  - o NEW COMPOSITE WHEELS @ 20,000 RPM CAN STORE  $2 \text{ KW-HR/FT}^3$
- o IAF MEETING OCT. 82
  - o AEROSPATIALE WORKING ADVANCED CONCEPTS
    - 33,000 RPM, 10-15 YR LIFETIME, HIGH EFFICIENCY
- o AEROSPATIALE INTERESTED IN COOPERATIVE PROGRAM

ELECTRICAL POWER TRADE-OFFS

Bob Giudici  
Marshall Space Flight Center  
Huntsville, Alabama

## APPROACH

Electrical power "trade studies" were initiated in September 1982 supporting the Space Station Systems Definition activity. Responsibility for performing the electrical power "trade studies" (Power Data Base) was divided between the NASA Centers. Center representatives and their respective subjects are identified in the accompanying chart.

The data base material was used to conduct a general storage trade study. When the results appeared to favor the flywheel option, effort was focused on a comparative flywheel investigation wherein a range of flywheel performance and cost possibilities was compared with optimistic projections of competing options.

### ● SYSTEM DEFINITION ACTIVITY (POWER DATA BASE)

- PHOTOVOLTAIC - GIUDICI
- FUEL CELLS - RICE
- NICD - SLIFER
- $\text{NH}_2$  - THALLER
- FLYWHEELS - KECKLER AND SLIFER
- SOLAR-THERMAL - BARNA

### ● GENERAL ENERGY STORAGE TRADES

- INITIAL AND 30-YEAR TOTAL WEIGHT AND COST
- ALTERNATE OPERATING POINT CONDITIONS FOR EACH ENERGY STORAGE OPTION
- 30 kW AND 75 kW SYSTEMS

### ● INTEGRATED CMG/FLYWHEEL INVESTIGATION

### ● INTEGRATED PROP + ECLS/RFC INVESTIGATION NEEDED

### ● INVESTIGATION OVER 18 TO 160 kW RANGE BEING CONSIDERED

## SYSTEMS LEVEL ASSUMPTIONS

Power requirements and orbit times used for the trade study are tabulated in the accompanying chart. Estimates of subsystem power loads were based on a brief analysis performed early in the Space Station Systems Definition activity and do not necessarily represent current Space Station planning.

● LOADS	75 KW SYSTEM KW
SUBSYSTEM SUN POWER	25
SUBSYSTEM DARK POWER	18
USER SUN POWER	50
USER DARK POWER	50
DISTRIBUTION LOSS	2% SUBSYSTEM, 7% USER
TOTAL OUTPUT, SUN	79.18
TOTAL OUTPUT, DARK	72.04

### ● ORBIT

- 250 N.MI.
- SUN TIME, .97 HRS., DARK TIME, .6 HRS



### FLYWHEEL ENERGY STORAGE SYSTEM

0 OUTPUT

- 75 kW System Rating
- 49 kWh Energy Storage Output
- Attitude Control

	STATE-OF-THE-ART FLYWHEEL (SOA-FW)	ADVANCED FLYWHEEL (ADV. - FW)	CMG
o LIFE	2 to 5 Years	30 Years	5 Years
o WEIGHT	19.1 Wh/kg	49 Wh/kg	1400 kg/6 Units
o D&D COST	\$35M	\$52M	\$28M
o RCR COST	\$35M	\$40M	\$16M
o PENALTIES	-\$3M	-\$3M	

- Delta Cost Below Array for Battery System  
(Solar Array + Launch + Drag)
- Delta Cost Above Equip. TCS for Battery System  
(NiCd Scaled by T<sup>4</sup>)

0 DEPTH-OF-DISCHARGE

- Nominal: 100% to 60%
- Reserve: 100% to 50%

### FLYWHEEL ENERGY STORAGE SYSTEM

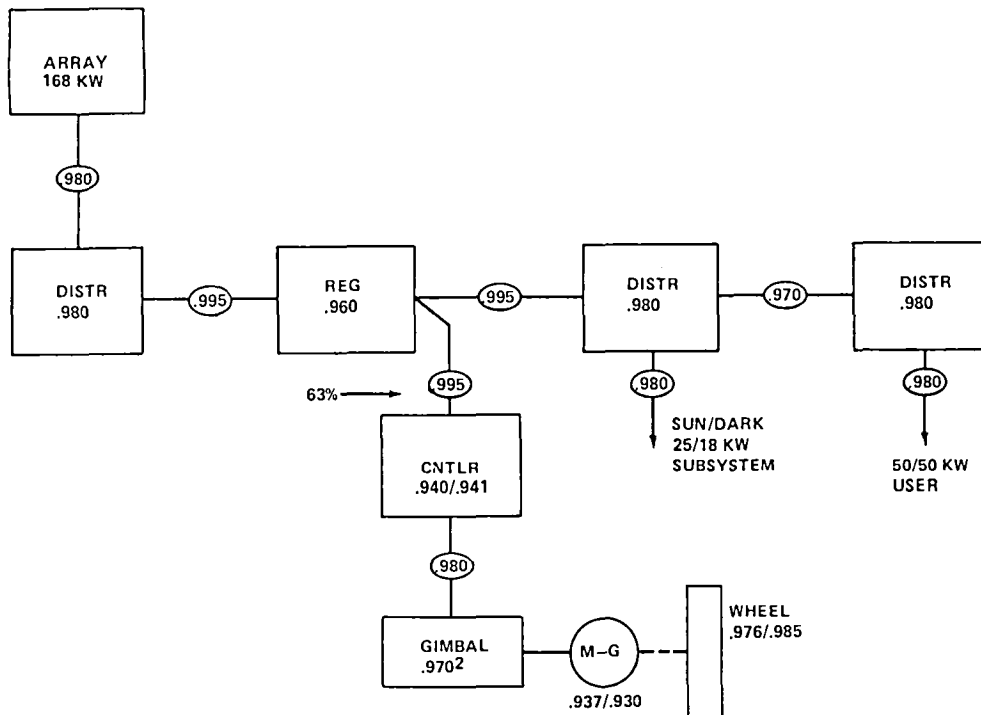

## RFC SYSTEM

0 OUTPUT:

- 75 kW System Rating
- 48.6 kWh Energy Storage Output
- 49 kWh Energy Storage Output
- 0 to 19 kg/day, H<sub>2</sub> and 0 to RCS/ECLS, 10 kg/Day Typical

0 LIFE: 5 Years

0 WEIGHT: 18 Wh/kg

0 D&D COST:

- \$30M Low Estimate
- \$150M High Estimate

0 RECURRING COST:

- \$50M
- Delta Cost Above Array for Battery System  
(Solar Array + Launch + Drag)
- Delta Cost Above Equiv. TCS for Battery System  
(NiCd Scaled by T<sup>4</sup>)
- No Credit Taken for Supplying 10 kg of H<sub>2</sub> and 0 to Prop. and ECLS  
(Potential Large Savings to other Subsystems)

## RFC SYSTEM

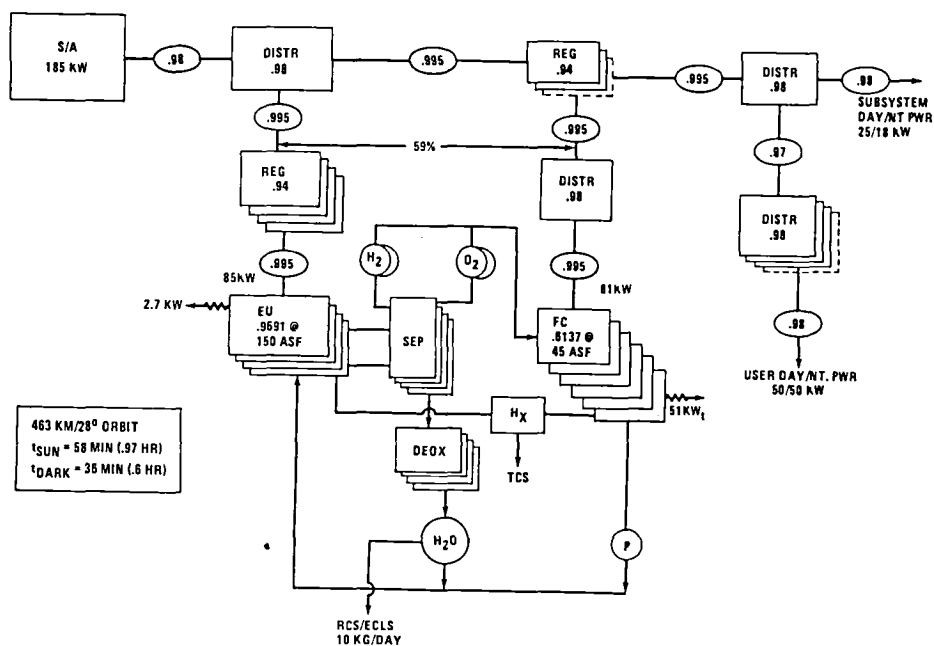

## BATTERY ENERGY STORAGE SYSTEMS 75 kW

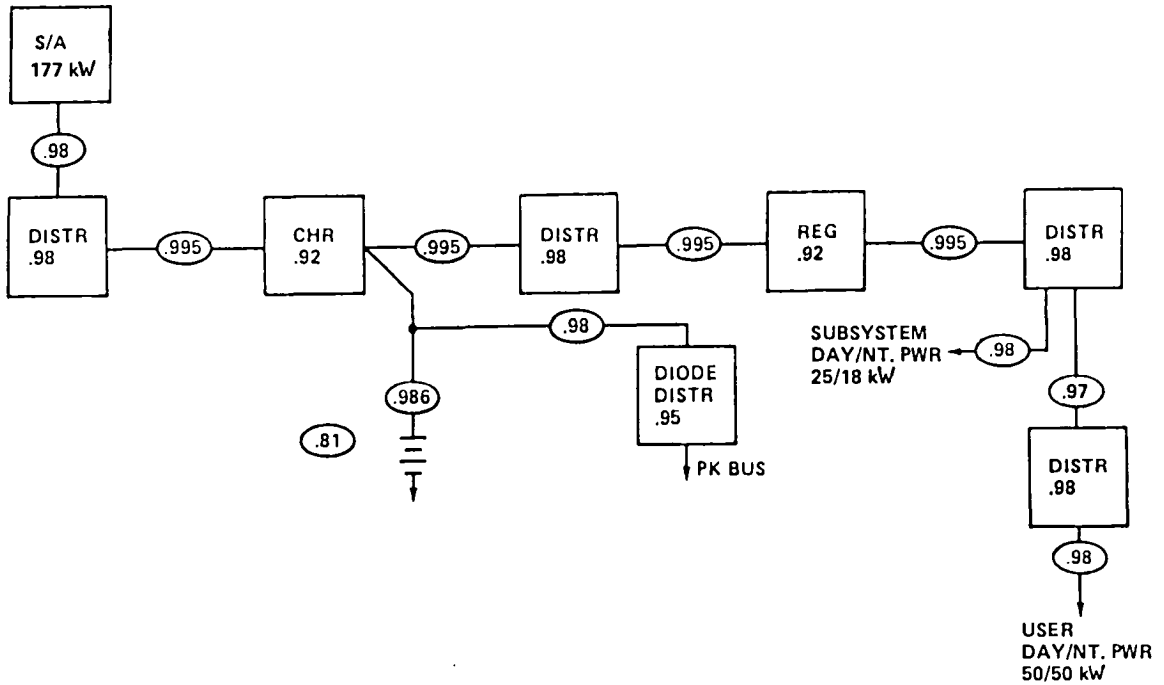

## BATTERY ENERGY STORAGE SYSTEMS

### OUTPUT

- 75kW System Rating
- 50 kWh Energy Storage Output

	OPTIMISTIC	CONSERVATIVE
LIFE	6.5 Years/30% DOD/0°C	5 Years/20% DOD/10 to 20°C
WEIGHT	26 Wh/kg 8.6 Wh/kg Usable	26 Wh/kg 5.2 Wh/kg Usable
D&D COST	\$2M	\$2M
RCR COST	\$150K/Battery 100 Batteries	\$330K/Battery 160 Batteries
PENALTIES	Reference Design	

LIFE CYCLE WEIGHT-TO-ORBIT

75-kW SYSTEM: ENERGY STORAGE + CMG

Weight-to-orbit stair step plots convey the order-of-magnitude weight reduction made possible by an advanced flywheel having the potential of a 30-year life. Similar plots made for 30-kW systems showed the same relative relationships between options. Plots were also made wherein advanced flywheels were phased into evolutionary growth scenarios replacing SOA flywheels. Results showed that the advanced flywheels must be phased in at an early point if an advantage over regenerative fuel cells is to be realized.

The merit of low weight systems was somewhat diluted in the cost analysis of the trade study. This was because typical D&D and FH cost estimating relationships would increase to the one-half power as a function of weight. Launch cost was fixed at \$1200/kg and was typically a small percentage of the total cost. As a result, a 50-percent weight differential between options might translate into only a 20-percent increase in total cost.

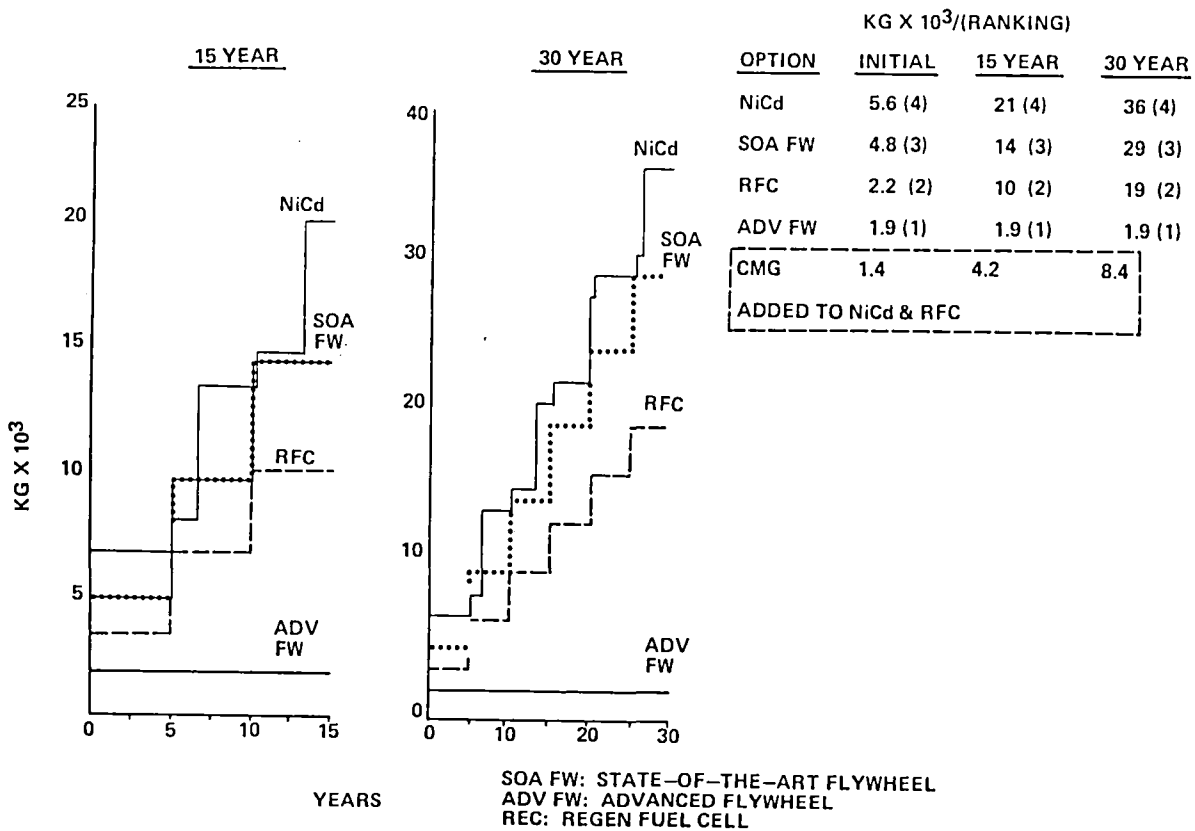

LIFE CYCLE ENERGY STORAGE COST - 75-kW SYSTEM

Results from the cost analysis were presented from three standpoints: (1) "Attitude Control only," (2) "Power only" and, (3) IPAC.

The "Attitude Control only" viewpoint may be purely hypothetical because the flywheels were sized for power rather than for attitude control. However, the comparison illustrates that even with the large oversizing, the advanced flywheel may be competitive with Skylab technology CMG's (blocks 1, 2, and 3).

Although trade studies conducted over the past decade have consistently rejected flywheels for "power only," results of the analysis suggest that flywheels may be the lowest cost approach (flywheels versus blocks 4 through 7).

The IPAC comparison indicated a clear advantage over separate CMG/power approaches, with the exception of the optimistic NiCd design versus the SOA flywheel.

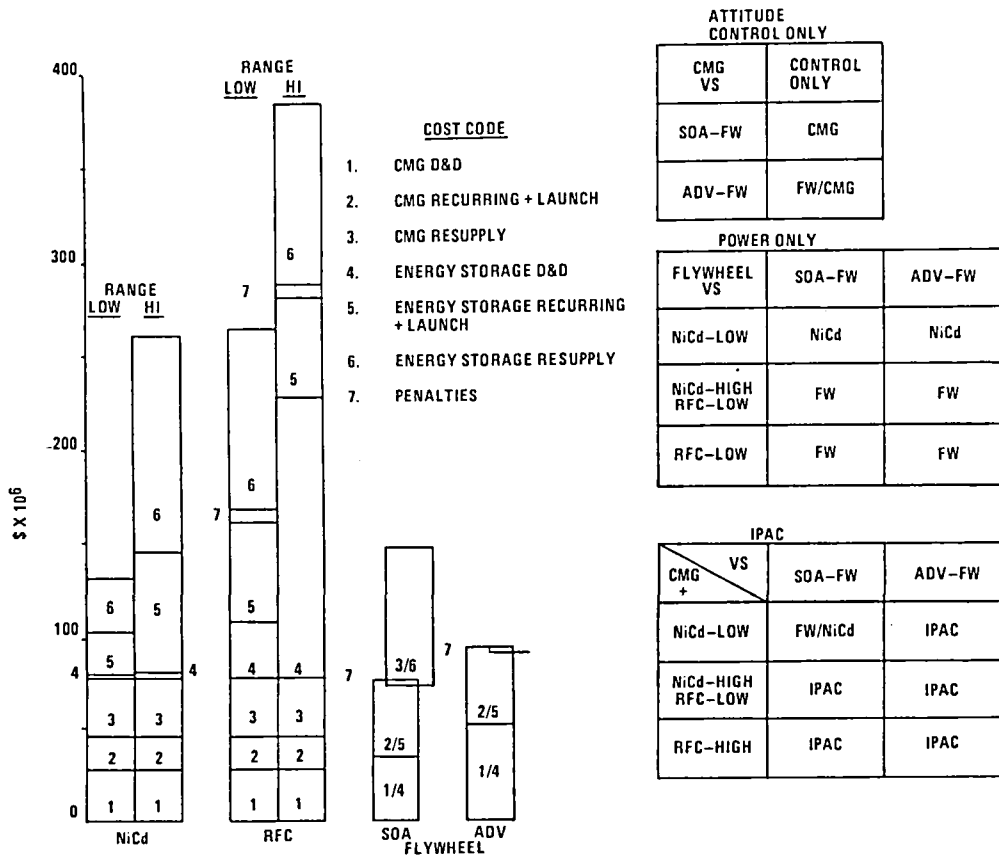

SPACE STATION ENERGY SIZING

Robert R. Rice  
Lyndon B. Johnson Space Center  
Houston, Texas

The chart below shows a general schematic for a space station power system. The major items of interest in the power system are the solar array, transfer devices, energy storage, and conversion equipment. Each item will have losses associated with it and must be utilized in any sizing study. Also, a chart like this can be used as a checklist for itemizing the various system components.

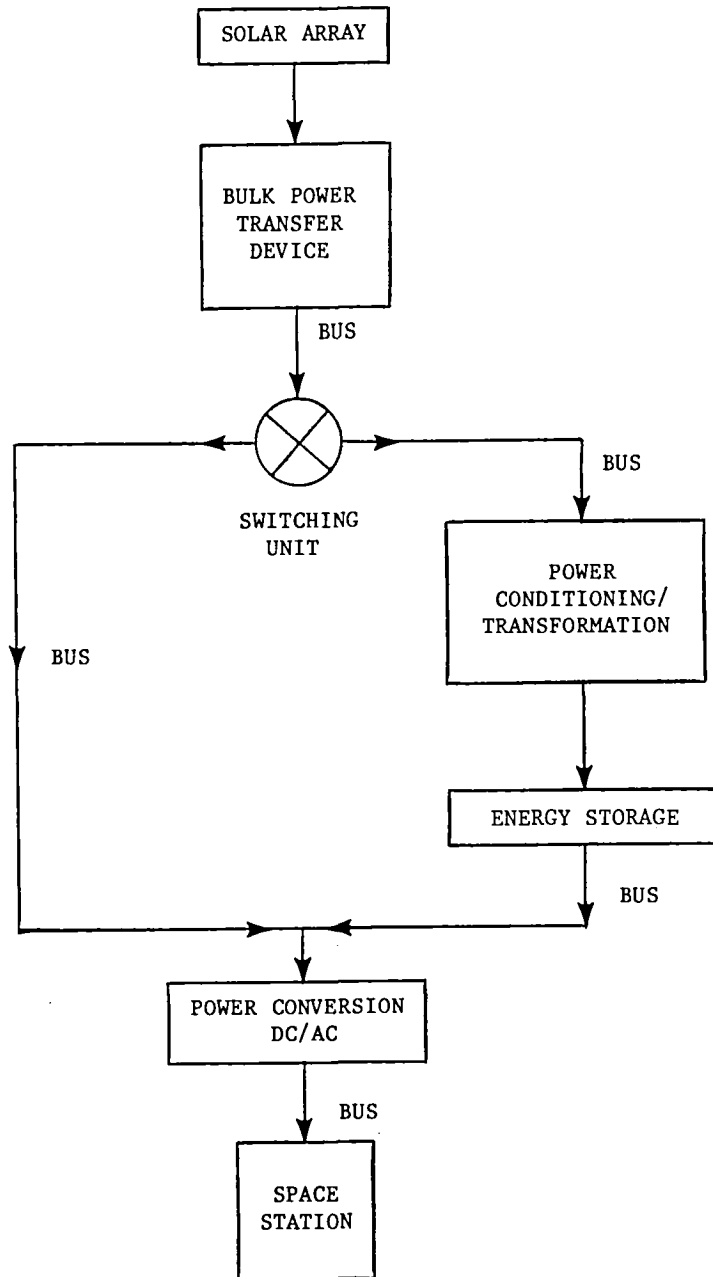

In the chart below, efficiencies have been assigned to each element of the power system. This must be done so that the required array size can be determined, and so that the sensibilities of the system can be examined by changing each item. Also, it should be obvious that the most efficient method of operating the station is to cycle the high loads on during the sun portion of the orbit so that the storage system is not utilized.

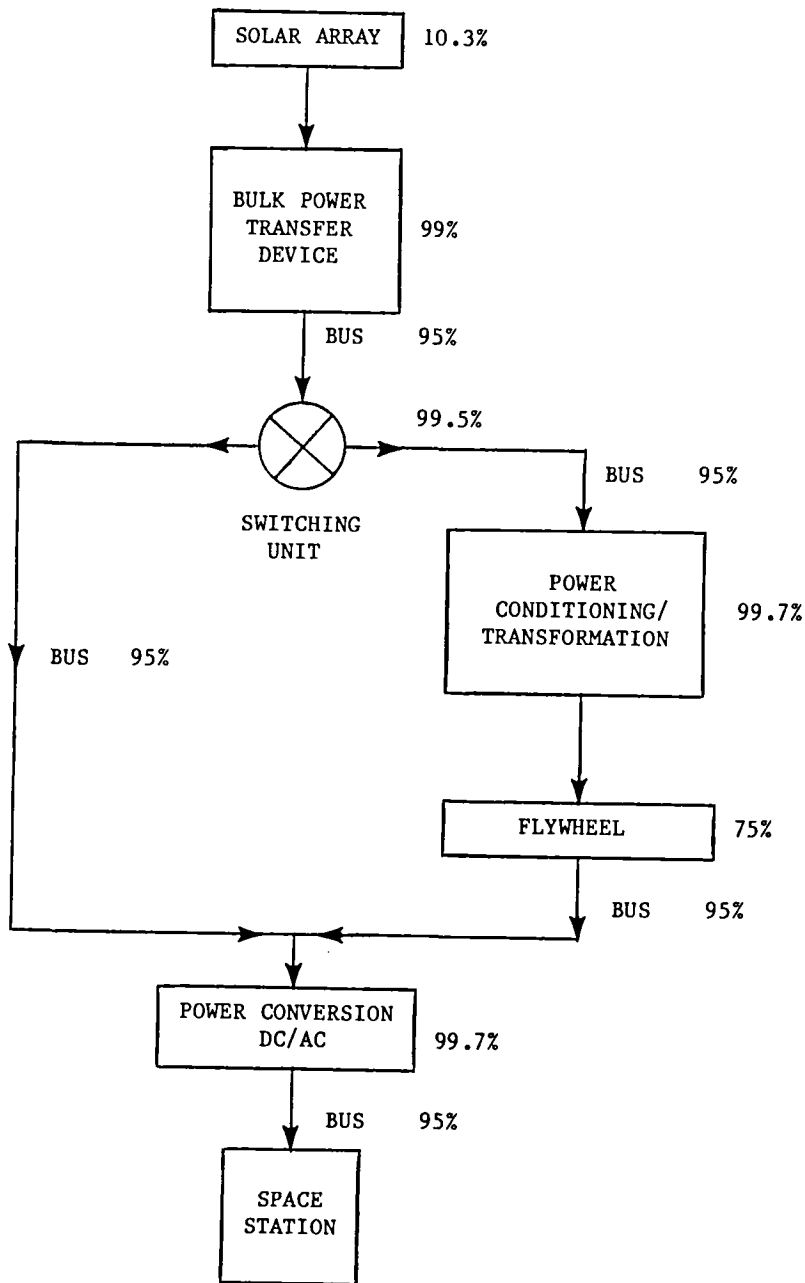



By performing an energy balance on the system, the relationship shown in the chart below can be derived. It should be noted that the output from this equation will not be linear. The term  $\eta_{FC}$  may be changed to fit whichever energy storage system that is of interest.

### EFFICIENCY CALCULATION

$$P_{SA} = \frac{P_{SS}}{\eta_{SA} \eta_{BPT} \eta_{SU} \eta_{PC} (\eta_B)^3} \left[ 1 + \left( \frac{TD}{TS} \right) \left( \frac{1}{\eta_{PCT} \eta_{FC} \eta_B} \right) \right]$$

$P_{SA}$  = POWER SOLAR ARRAY

$P_{SS}$  = POWER SPACE STATION

TD = TIME ON DARK SIDE

TS = TIME ON SUN SIDE

$\eta_{SA}$  = EFFICIENCY OF SOLAR ARRAY (10.3%)

$\eta_{BPT}$  = EFFICIENCY OF BULK POWER TRANSFER DEVICE (99%)

$\eta_{SU}$  = EFFICIENCY OF SWITCHING UNIT (99.5%)

$\eta_{PC}$  = EFFICIENCY OF POWER CONVERSION - DC/AC (99.7%)

$\eta_B$  = EFFICIENCY OF BUS (95%)

$\eta_{PCT}$  = EFFICIENCY OF POWER CONDITIONING/TRANSFORMATION (99.7%)

$\eta_{FC}$  = EFFICIENCY OF REGENERATIVE FUEL CELL (RFC) (55%)

The results of the study are shown in the chart below. The three curves show the effects of array degradation with time, and the conclusion that can be drawn from them is that the array degradation can be a major effect on the system size. Also, it can be seen that as the energy storage system efficiency increases, the overall array size is reduced. One final conclusion that can be reached from this chart is that the size of the power systems that are currently being considered is much larger than any that have ever been flown before.

### ARRAY SIZE, KW

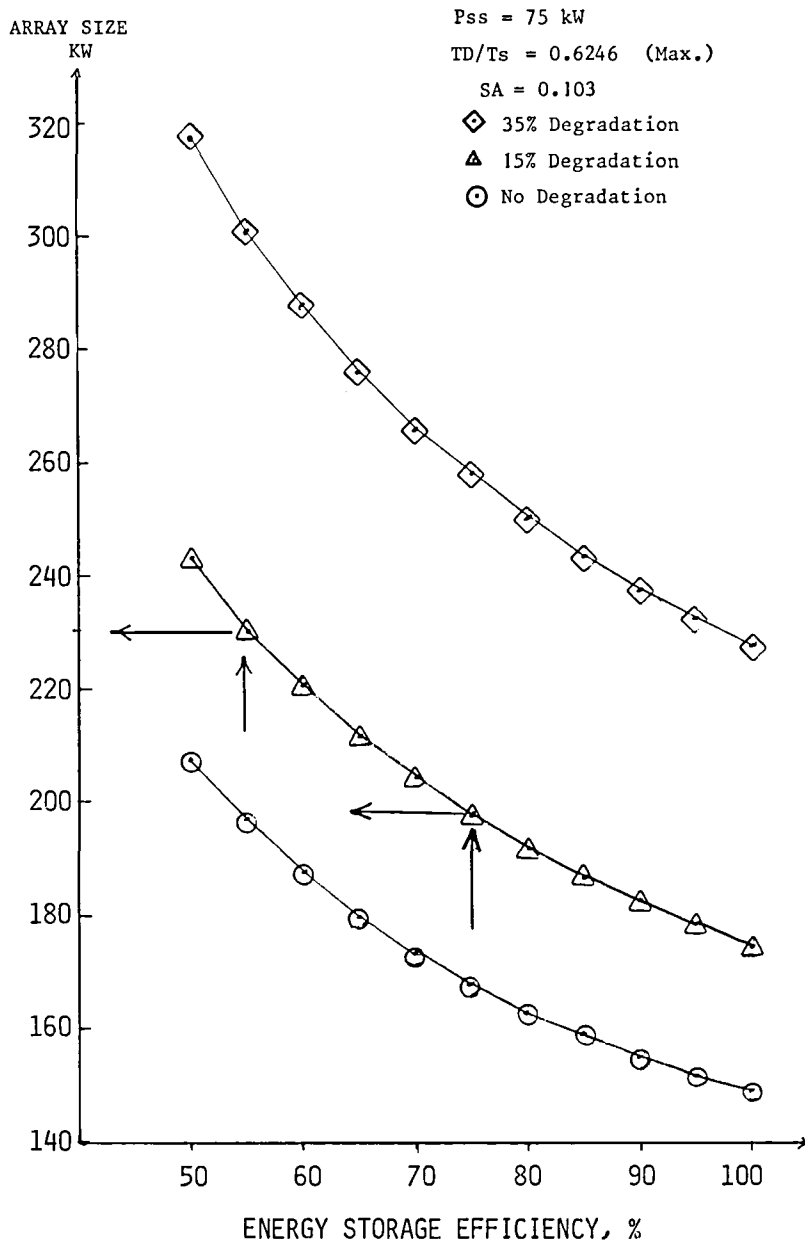

The array size in square meters is shown in the chart below. This curve is a direct conversion from the previous page and gives a general feel for the system sizes. For example, the current range of sizes for the Space Station is 1,300 to 1,550 square meters (i.e., 13,731 ft<sup>2</sup> to 16,371 ft<sup>2</sup>). This means that the solar array will end up being the dominant feature of the station and will greatly influence such things as configuration, operations, and control. Since the arrays are becoming so big, then anything that reduces their size will be of great help. The use of flywheels is very attractive from this point of view, since they offer efficiencies in the 75 percent range.

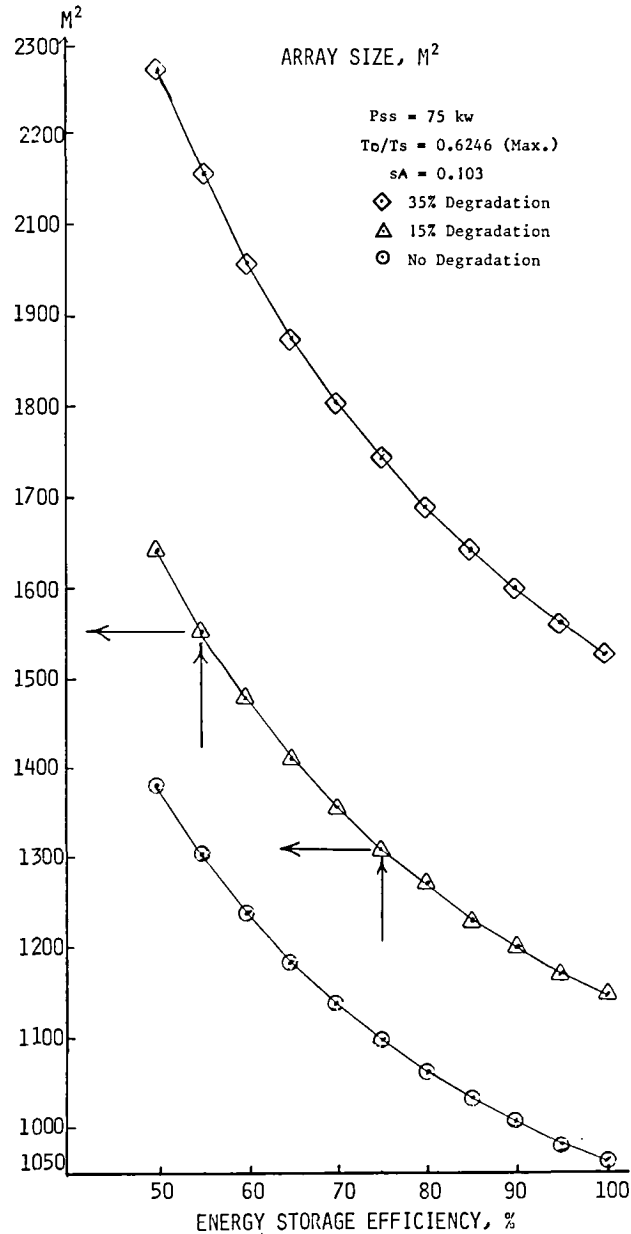

SPACE STATION ATTITUDE CONTROL SYSTEM  
CONCEPT AND REQUIREMENTS

P. D. Nicaise  
Marshall Space Flight Center  
Huntsville, Alabama

## SPACE STATION BALANCED CONCEPT

There is currently no single Space Station configuration which is accepted as a baseline. However, the latest approach is toward symmetry in both geometry and mass distribution. This minimizes aerodynamic and gravity gradient torques. Solar arrays and radiators drive the configuration strongly. One axis of the solar arrays needs to be perpendicular to the orbit plane, and the geometric and principal axis should remain common along this axis to minimize secular torques. The need for both inertial and earth-fixed modes drives the structure of the Station toward a disk-like shape in the orbital plane.

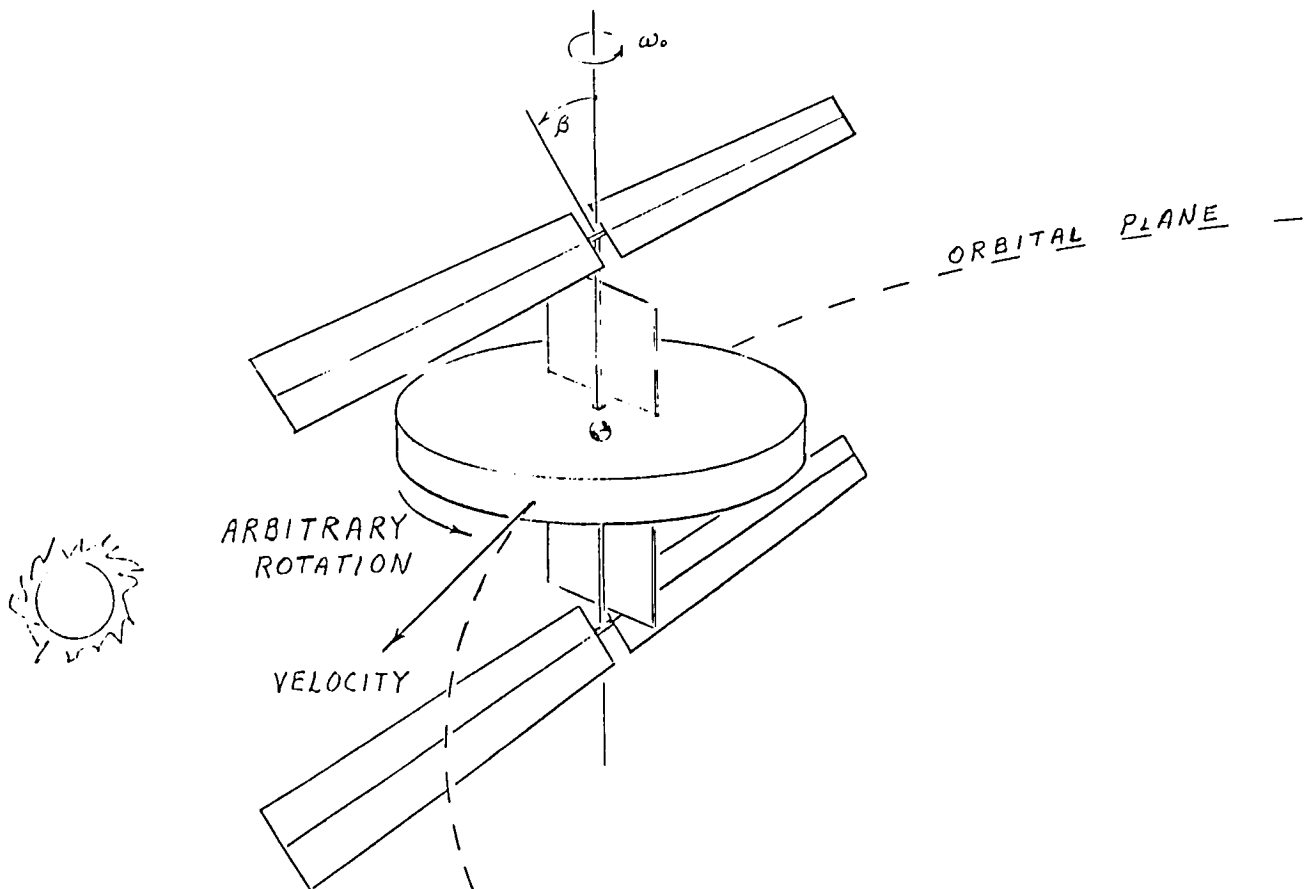

# SPACE STATION

## CENTRAL BOOM APPROACH

One approach to a balanced concept is a central boom which passes through the common core structure and provides independent rotation for the radiators and solar arrays. The arrays can then have continuous rotation using roll rings to transfer power and the radiator rotation can be limited to permit fluid transfer using flex lines. The remainder of the structure is built into a disk-like shape using standard, pressurized modules for living quarters and rigid support arms for mounting experiments for stowage. The Station can assume either an inertial or earth fixed attitude using a combination of momentum exchange devices and magnetic torquer bars. Cold gas thrusters are used for emergency backup and suppression of large transients such as Shuttle docking disturbances.

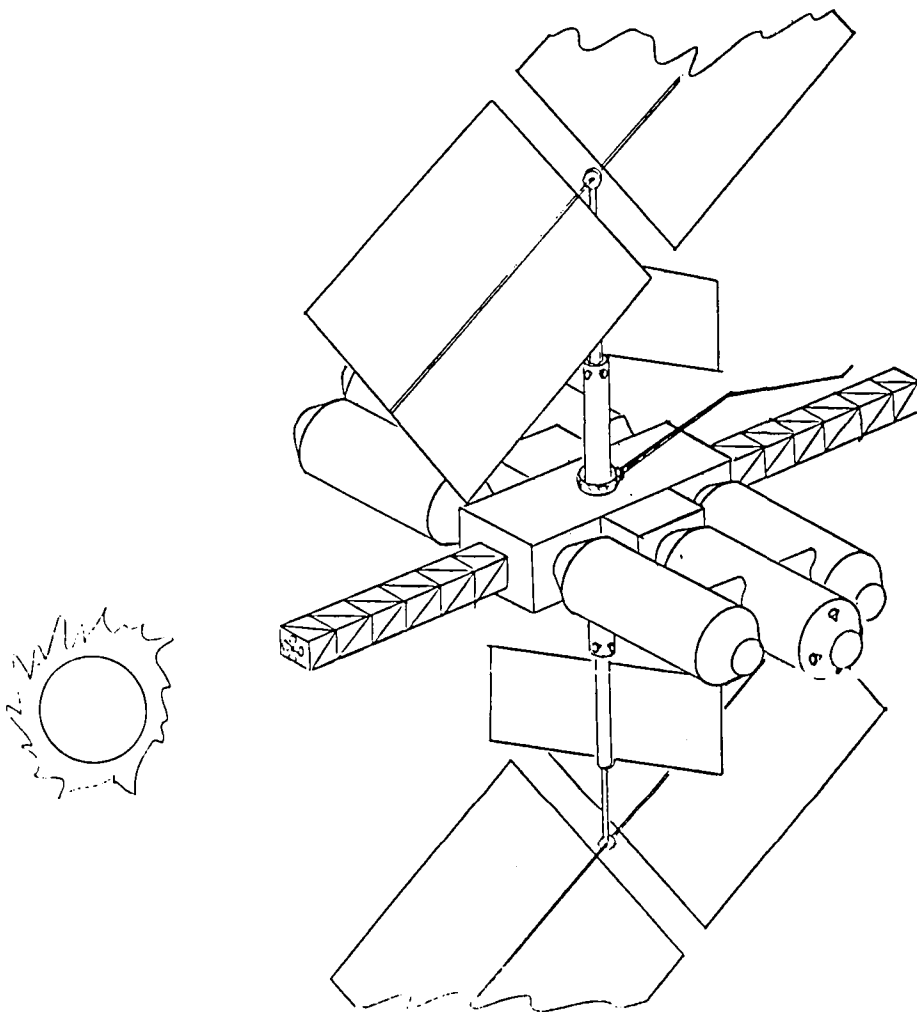

SPACE STATION  
CONTROLLABILITY FACTORS

This table shows the torque and momentum capacity of a typical CMG and thruster system which could be used for Space Station control. Sensitivity factors are given for aerodynamic and gravity gradient disturbances. Therefore it is possible to estimate the amount of control authority required for variations in Station characteristics which affect CG/CP offset and inertia distribution.

TYPICAL EFFECTOR CHARACTERISTICS

SKYLAB TYPE CMG:

MAX. TORQUE OUTPUT	165 N.M.
MOMENTUM CAPACITY	3120 N.M.S

TYPICAL RCS: (2 X 100 N THRUSTERS AT 10M)

TORQUE OUTPUT	2000 N.M.
MOMENTUM OUTPUT/S	2000 N.M.S

DISTURBANCE PARTIALS

AERODYNAMIC: (CDG CONFIG. AT 500 KM)

MAX. TORQUE/M CP/CG OFFSET	1.28 N.M
HALF-ORBIT MOMENTUM BUILDUP/M	2310 N.M.S

GRAVITY GRADIENT: ( $\Delta I = 10^6$  N.M,S<sup>2</sup> AT 500 KM)

MAX. CYCLIC TORQUE (INERTIAL, POP AXIS)	1.83 N.M.
QUARTER-ORBIT MOMENTUM BUILDUP	1658 N.M.S

SECULAR TORQUE/DEG. (INERTIAL, DEVIATION FROM POP)	0.064 N.M
--	-----------

SECULAR MOMENTUM BUILDUP/DEG/ORBIT	182 N.M.S
------------------------------------	-----------

SPACE STATION  
DISTURBANCE SOURCES

The transient type disturbances shown in this table were supplied by the Boeing Company under the Advanced Platform Systems Technology Study (ref. 1). These values have been used in our sizing study. However, recent Shuttle flight experience indicates that these numbers are somewhat conservative, since translational and rotational residuals are about one-half of the assumed value.

Disturbance Source	Characteristics (and Assumed) Values	Corresponding Disturbance Momentum
Orbiter Docking	Orbiter nominal approach: Linear velocity - 0.015 m/s Angular rate - 0.2 deg/s Space Station C.G. offset 1.0 m Orbiter Mass 84,000 kg	1,260 N m s 34,900 N m s
Crew Activity	Push off and free flight inside work space or habitat module: Crew member mass 100 kg Free flight velocity 0.4 m/s Flight path offset 10 m from station C.G.	400 N m s
Module Transfer from Orbiter payload bay to Space Station berthing port	Habitat module transfer Mass 20,000 kg Transfer rate 0.1 m/s Transfer path offset 10 m from C.G.	20,000 N m s

(From ref. 1)



## SPACE STATION

### EFFECTOR SIZING

An estimate of momentum storage requirements is made by considering the gravity gradient and aerodynamic cyclic torques which could be expected on a typical balanced configuration. The number of CMG's is calculated for the basic Station and the Station with Shuttle docked. It is pointed out that the large cyclic momentum with Shuttle docked can be eliminated by going to an Earth-fixed mode. In this case, despin of the arrays during darkness was considered as an additional disturbance source.

- MOMENTUM STORAGE CAPABILITY IS BASED ON THE EXPECTED MAXIMUM CYCLIC MOMENTUM.

	BASIC STATION	SHUTTLE DOCKED
G.G. FOR INERTIAL HOLD ABOUT POP AXIS	14,990*	44,608*
AERO 2M/6M CP/CM OFFSET	4,620	13,860
<hr/>		
TOTAL H FOR INERTIAL MODE (N.M.S)	19,610	58,468
# SKYLAB TYPE CMG'S REQUIRED	3.1	9.4

\*NOTE: THESE VALUES VANISH FOR EARTH-FIXED MODE, BUT THE ARRAY DESPIN BECOMES A FACTOR UNLESS CONTINUOUS ROTATION IS ALLOWED, DESPIN AND REPOSITION REQUIRES ABOUT 16,000 N.M.S PER ORBIT FOR THE 75 kW ARRAY.

TOTAL H WITH DESPIN (N.M.S)	20,620	29,860
# SKYLAB TYPE CMG'S REQUIRED	3.3	4.8
# CMG'S RECOMMENDED		6

## REFERENCE

1. Gross, Sidney: Analysis of Regenerative Fuel Cells. Rept. No. D180-27160-1, Boeing Aerospace Corp., Nov. 1982.

**Page intentionally left blank**

THE BOEING FLYWHEEL STUDY

Robert R. Rice  
Lyndon B. Johnson Space Center  
Houston, Texas

## THE BOEING STUDY HISTORY

The major features of the history of the Boeing flywheel study are shown in the figure below. An initial study performed for the analysis of the regenerative fuel cell was started as an outgrowth of the original Boeing study of the Space Operations Center. This study was completed in November 1982 with the publication of the final report number D180-27160-1 (ref. 1). The current flywheel effort will attempt to study the integrated flywheel using the same ground rules that were used on the fuel cell study.

- INITIAL STUDY
  - ANALYSIS OF REGENERATIVE FUEL CELL
  - CONTRACT NAS9-16151
  - FINAL REPORT - DATED NOVEMBER 1982
- BASED ON INITIAL STUDY
  - RECYCLE EFFORT FOR FLYWHEELS
  - SHOULD GIVE A COMPARISON OF FLYWHEELS AND REGENERATIVE FUEL CELLS USING THE SAME GROUNDRULES

THE BOEING CONTRACT

The major features of the flywheel study are shown in the chart below.

BOEING CONTRACT NAS9-16151

PRINCIPAL INVESTIGATOR: SID GROSS, (206) 773-1198

START: MARCH 1983

FINISH: OCTOBER 1983

LENGTH: EIGHT MONTHS

COST: \$49,000

CONTRACT MONITOR : KEITH E. VAN TASSEL  
(713) 483-3133

## THE FLYWHEEL STUDY TASK

The major divisions of the study are shown in the figure below, and a discussion of each follows.

1. Requirements and Guidelines. Typical Space Station requirements and guidelines will be defined, both for energy storage and attitude control.
2. Electrical Power Systems Study. Electrical power systems based on flywheels will be defined and analyzed. Components in the system will be identified and their impact on the system determined. Approaches to launch, emergency power, and other power systems needs will be determined and analyzed. Overall system efficiency and the opportunities to develop high efficiency energy storage systems will be determined, along with the advantages and penalties of such high efficiency systems. The applicability to high power, short duration loads will be assessed.
3. Integration with Momentum Management System. Integration of the flywheel energy storage system with the momentum management system will be studied. Approaches to be studied will include counter-rotating wheels, gravity gradient, solar pressure, magnetic torquing, multiple reaction wheels, isolation methods, and special approaches for precision attitude control.
4. Assessment of Benefits and Penalties of Flywheels. An assessment will be prepared of the benefits and penalties associated with the use of flywheel systems. Comparisons with electrochemical energy storage system will be made.
5. Documentation. Monthly letter reports will be prepared. A final report will be prepared and will include all significant information generated during the study. A final draft report will be submitted prior to issuance of the final report. A presentation of results will be made at NASA prior to issuance of the final report.

### STATEMENT OF WORK

- REQUIREMENTS AND GUIDELINES
- ELECTRICAL POWER SYSTEMS STUDY
- INTEGRATION WITH MOMENTUM MANAGEMENT SYSTEM
- ASSESSMENT OF BENEFITS AND PENALTIES OF FLYWHEELS
- DOCUMENTATION

## THE FLYWHEEL STUDY STATUS

The status of the program is shown in the figure below. In general, the study is in the beginning phase where information is being gathered to form a data base for the remainder of the study.

### BOEING CONTRACT

- \$49,000 - 8 MONTHS
- ASSESS FEASIBILITY OF INTEGRATION WITH ATTITUDE CONTROL
- PRELIMINARY INDICATION IS THAT ATTITUDE CONTROL CONSTITUTES ONLY ABOUT 10 PERCENT OF ENERGY STORAGE WEIGHT
- STUDY IS THREE MONTHS ALONG

### REFERENCE

1. Gross, Sidney: Analysis of Regenerative Fuel Cells. Rept. no. D180-27160-1, Boeing Aerospace Corp., Nov. 1982.



**Page intentionally left blank**

SPACE STATION CONTROL REQUIREMENTS AND  
FLYWHEEL SYSTEM WEIGHTS FOR  
COMBINED MOMENTUM AND ENERGY STORAGE

Frank M. Elam  
Johnson Space Center  
Houston, Texas

## SPACE STATION CONTROL REQUIREMENTS

The specifications of the flywheel system for momentum storage and vehicle torquing are somewhat dependent upon the attitude control requirements of the space station in orbit. As a ground rule, the flywheel system will be sized large enough to provide all attitude maneuvers, if practical, to avoid or minimize turning on the reaction control system (RCS). The RCS, whenever used, expels expensive mass and tends to contaminate optical surfaces of the vehicle. The vehicle rate and acceleration specifications of 0.10 deg/sec and 0.01 deg/sec<sup>2</sup> are tentative, and may be reduced if lesser values are more practical for flywheel design. For local vertical attitude hold, the average attitude error should be zero, and not the classical 1 degree, since control moment gyro (CMG) gimbal angles provide an exact reference feedback for gravity gradient momentum. Docking presents a problem for docking transients and attitude alignment which will require use of the RCS.

ATTITUDE MANEUVER RATE 0.10 DEG/SEC

- PROVIDED IN EACH AXIS
- PROVIDED BY CMG OR REACTION WHEEL
- WITHOUT ASSIST BY RCS - IF PRACTICAL

ATTITUDE MANEUVER ACCELERATION 0.01 DEG/SEC<sup>2</sup>

- PROVIDED IN EACH AXIS
- PROVIDED BY CMG OR REACTION WHEEL
- WITHOUT ASSIST BY RCS - IF PRACTICAL

ATTITUDE HOLD MODES

- ONE AXIS P·O·P - ONE AXIS LOCAL VERTICAL
  - PRINCIPAL AXES - NOT BODY AXES
- ONE AXIS P·O·P· - THREE AXES INERTIAL ATTITUDE HOLD
  - PRINCIPAL AXES - NOT BODY AXES
- WILL NOT FLY WITH DEVIATIONS FROM THESE TWO MODES
  - AVERAGE ERROR WILL BE ZERO, NOT ONE DEGREE
- EXCEPT WILL DEVIATE TO CREATE GRAVITY GRADIENT TORQUES TO OFFSET AERO TORQUES AND SOLAR TORQUES
- EXCEPT - DOCKING MANEUVER WILL ALIGN DOCKING PORT CO-LINEAR WITH VELOCITY VECTOR IN ORBIT PLANE.

## SPACE STATION CONTROL REQUIREMENTS (CONTINUED)

### GROUND RULE:

- CMG'S OR REACTION WHEELS WILL BE LARGE ENOUGH TO HANDLE ATTITUDE MANEUVERS AND CYCLIC TORQUES WITHOUT USING RCS
- RCS WILL BE USED ONLY FOR DELTA VELOCITY FOR ORBIT ALTITUDE MAKEUP AND ORBIT CHANGE. ALSO CMG DESATURATION IF NECESSARY.
- ONLY DELTA X VELOCITY BY RCS WILL BE PROVIDED.
- DESIGN TARGET: TO DESIGN MASS AND SHAPE TO AVOID OR MINIMIZE REQUIREMENT TO DESATURATE CMG'S USING RCS.
- DESIGN TARGET: TO CREATE USEFUL GRAVITY GRADIENT TORQUES BY SMALL ATTITUDE DEVIATIONS TO CANCEL OUT AERO TORQUES AND SOLAR PRESSURE TORQUES OVER AN INTEGRATED TIME PERIOD.

### PRECISION POINTING

- WILL BE PROVIDED BY VERNIER PLATFORMS, NOT BY THE MAIN SPACE STATION BODY.
- POINTING ACCURACY OF MAIN BODY IS TBD, BUT WILL NOT BE SUPER PRECISION, MERELY "PRACTICAL"
- AVERAGE POINTING ERROR (WHICH ACCUMULATES UNWANTED GRAVITY GRADIENT TORQUES) WILL BE INTEGRATED TO ZERO USING ACCUMULATED MOMENTUM AS FEEDBACK, (OR ERROR SNAP-SHOT AT ORBITAL INTERVALS.)
- A STUDY IS BEING CONDUCTED ON PRECISION POINTING REQUIREMENTS OF VARIOUS EXPERIMENTS, ETC.

### REVOLVING PLATFORMS (WITH RESPECT TO MAIN BODY)

- UNDER DESIGN CONSIDERATION
- WITH SPACE STATION IN LOCAL VERTICAL ATTITUDE-HOLD, SMALLER PLATFORMS WOULD BE IN INERTIAL HOLD, REVOLVING RELATIVE TO MAIN BODY, PLUS PRECISION VERNIER PLATFORMS ON THE "REVOLVING" PLATFORM.
- WITH SPACE STATION IN INERTIAL ATTITUDE HOLD (ONE AXIS P-O-P.), SMALLER REVOLVING PLATFORMS WOULD BE IN LOCAL VERTICAL ATTITUDE HOLD, PLUS PRECISION VERNIER PLATFORMS ON THE "REVOLVING" PLATFORM.
- NOTE THAT A "REVOLVING" PLATFORM THAT IS DESIGNED FOR THE INERTIAL HOLD MODE WILL ALSO FUNCTION IN THE LOCAL VERTICAL MODE, AND VICE VERSA.
- FOR EXTREMELY VIBRATION-FREE, ZERO-G LABORATORIES, CO-ORBITING SATELLITES WILL BE USED.

### FLEXIBLE BODY BENDING MODES

- DAMPING WILL BE PROVIDED
  - BY CMG OR REACTION WHEEL (INERTIAL DEVICES)
  - OR BY ACTIVE ACTUATORS OR PASSIVE DAMPERS ATTACHED BETWEEN TWO STRUCTURAL POINTS
- SOFT CONSTRAINT DE-COUPLING BETWEEN MAJOR MODULES IS BEING CONSIDERED

# SPACE STATION - STRUCTURAL CONFIGURATIONS

The next five charts show pictorials of several space station structural configurations. This study presented flywheel system requirements for several of these configurations.

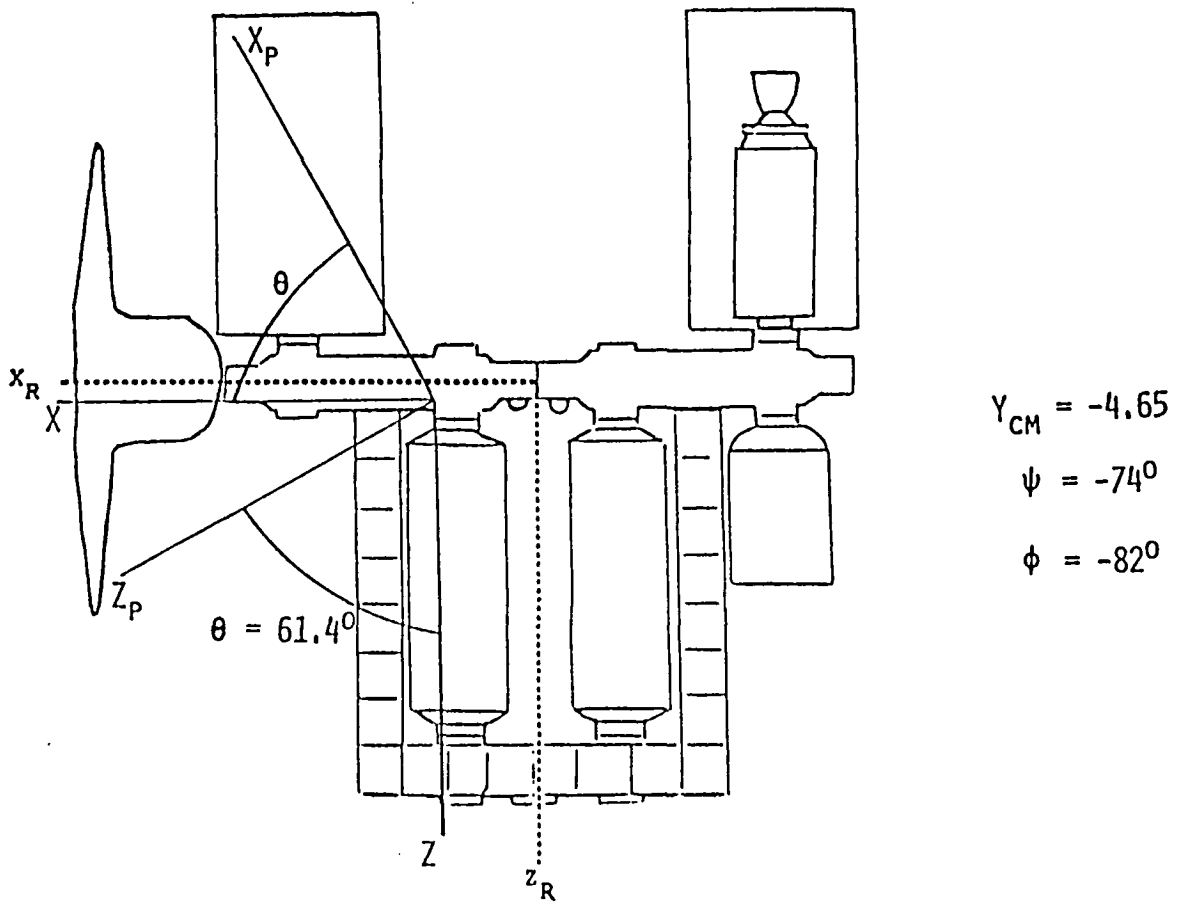

BOEING PHASE "A" STUDY  
CONFIGURATION II

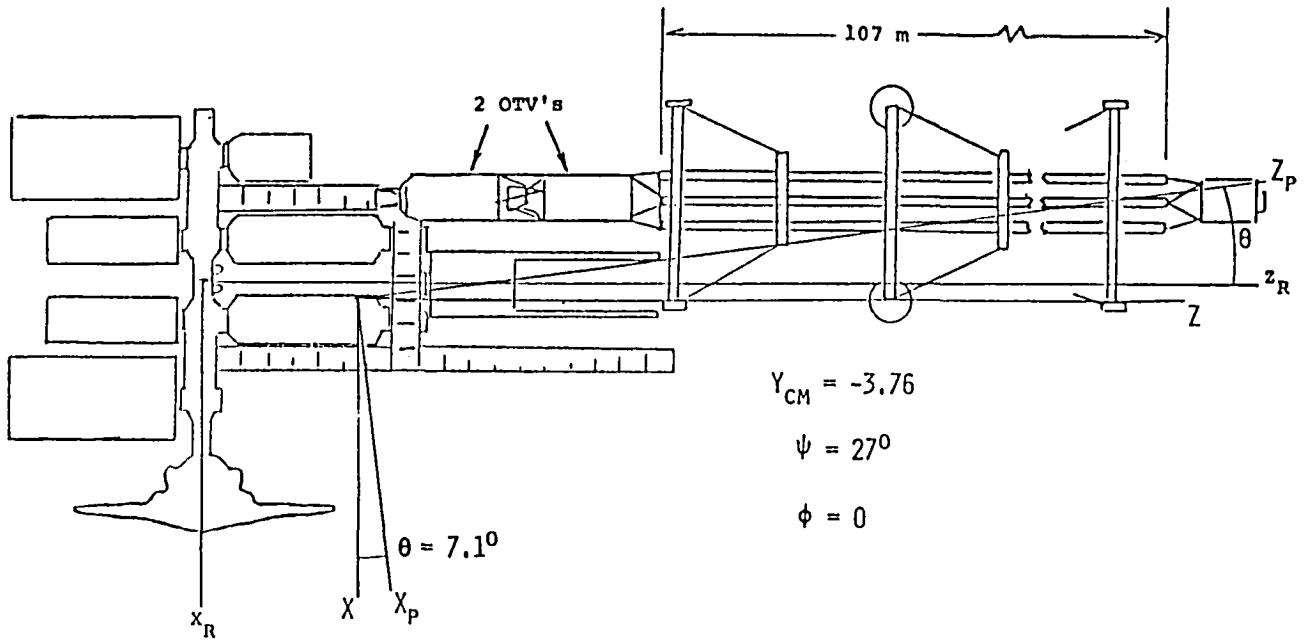

BOEING PHASE "A" STUDY  
CONFIGURATION III (GIANT)

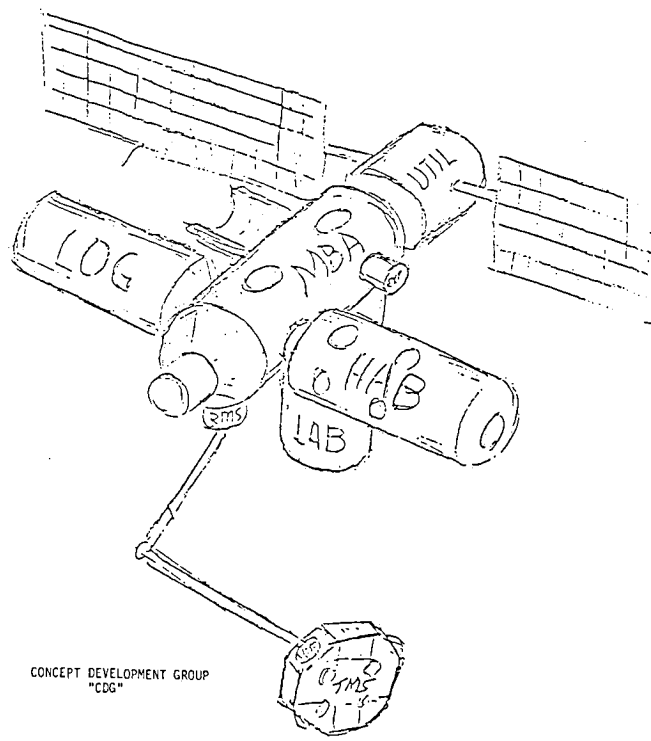

CONCEPT DEVELOPMENT GROUP  
"CDG"

SPACE STATION  
(CDG CONCEPT)

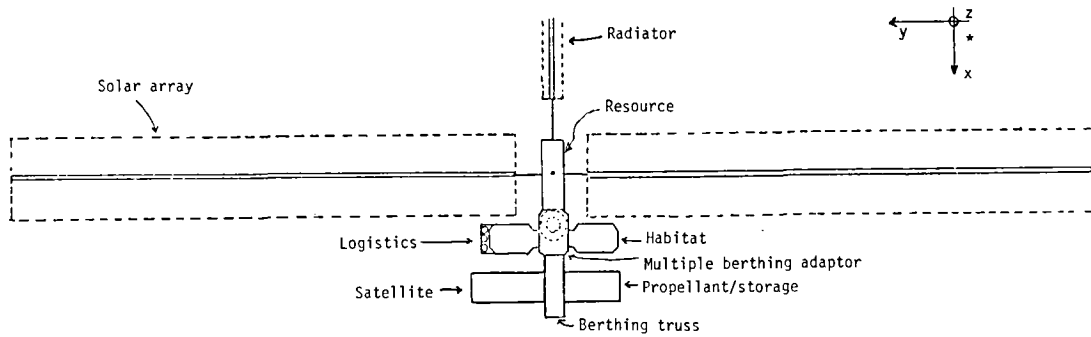

\*Reference frame origin at center of resource module.

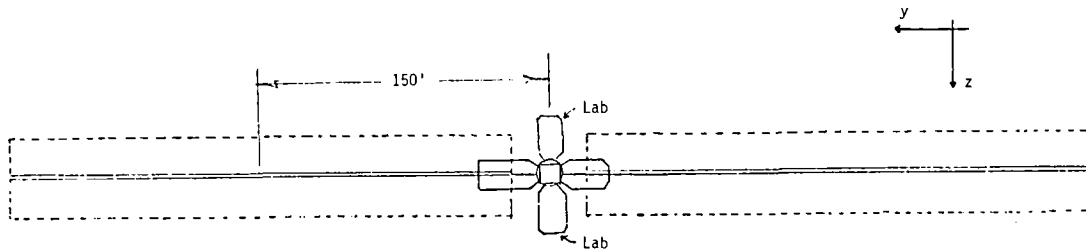

CONFIGURATION AND COORDINATES  
(CDG CONCEPT)

TRIANGULAR SOC

CONFIGURATION: SOC WITH ORBITER OUTSIDE

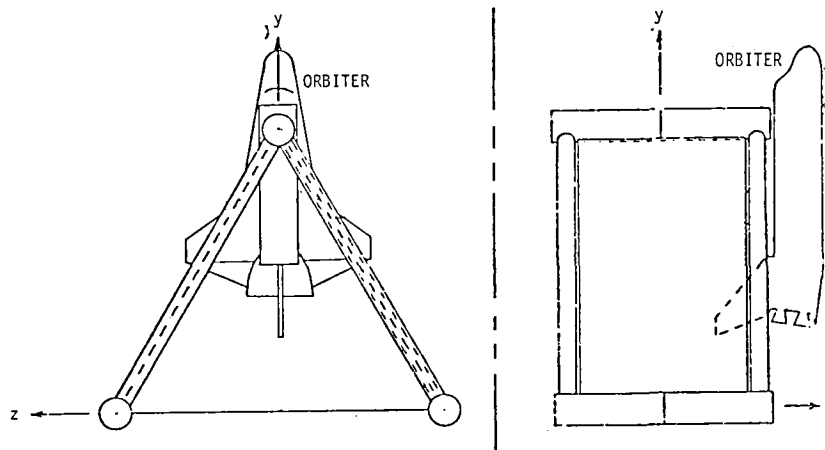

TOTAL MASS = 15800 SLUGS

CENTER OF MASS LOCATION: X=22.1 , Y=57.5 , Z=2.6 FEET

MOMENTS OF INERTIA (THROUGH CENTER OF MASS):

$I_{xx}=6.98 \times 10^7$ ,  $I_{yy}=4.88 \times 10^7$ ,  $I_{zz}=6.08 \times 10^7$ ,  $I_{yz}=-1.96 \times 10^6$ ,  $I_{xz}=-2.81 \times 10^4$ ,  $I_{xy}=8.24 \times 10^6$

PRINCIPLE MOMENTS OF INERTIA, NO SPECIAL ORDER (SLUG\*FEET\*\*2):

I.D.	M.O.I.	DIRECTION COSINES		
1	$7.27 \times 10^7$	X: 0.942585	Y: -0.329849	Z: -0.052271
2	$4.57 \times 10^7$	X: 0.321706	Y: 0.938813	Z: -0.123028
3	$6.10 \times 10^7$	X: 0.089653	Y: 0.099149	Z: 0.991026

IPACS APPLICATION TO EXTENDED ORBITER  
(Integrated Power and Attitude Control System)

Shown here is the physical arrangement of a flywheel system which contains three double-gimbal control moment gyros (CMG'S). The system provides attitude control torques and angular momentum management by gimbaling the flywheels. The energy storage function is provided by changing the RPM of the flywheels using motor generators. Also shown is a solar cell array to convert sunshine into electricity.

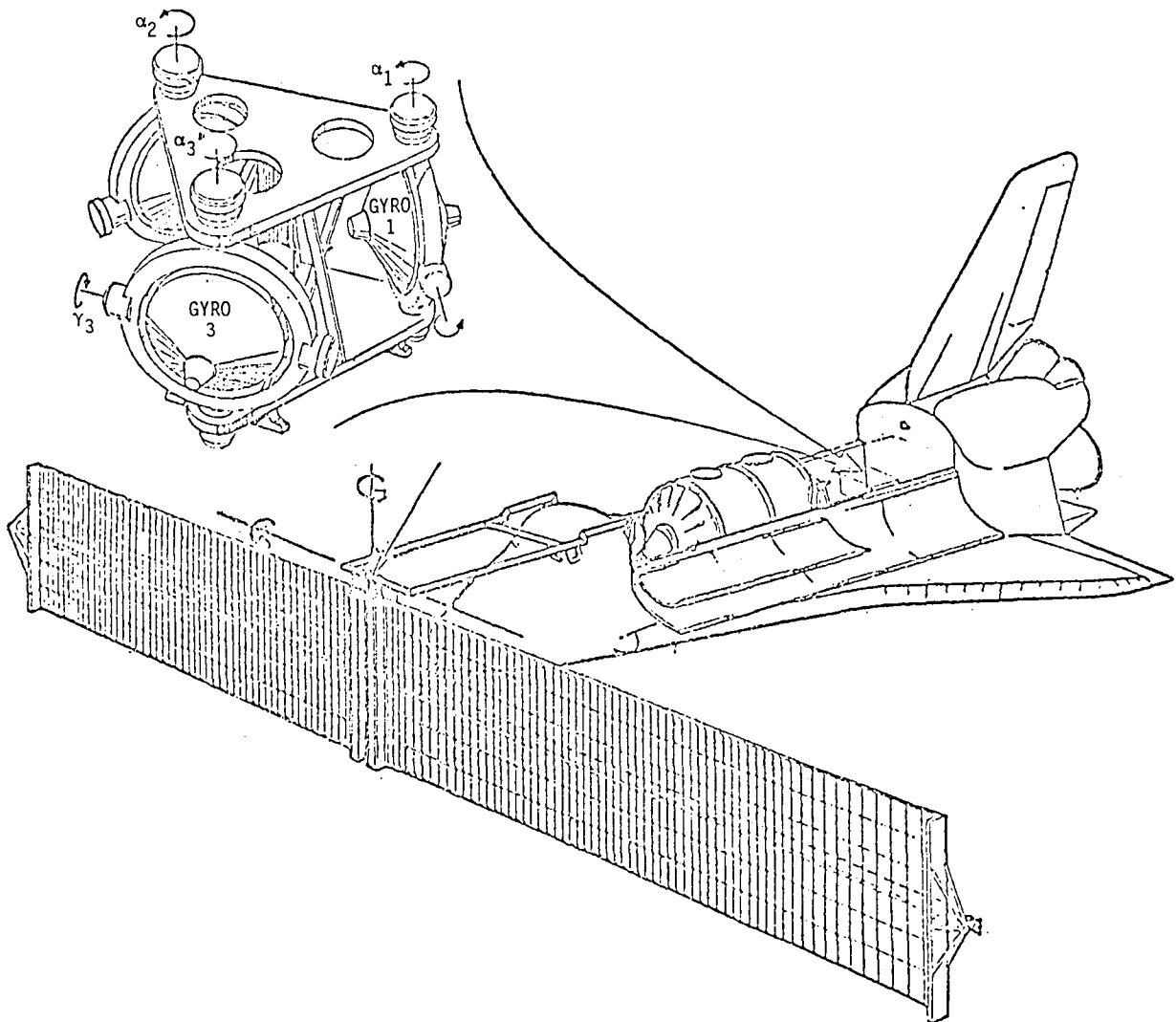



## IPACS FOR EXTENDED DURATION ORBITER - WEIGHTS

This chart is taken from a 1974 presentation and study by Rockwell International on the design and weight of a flywheel system called IPACS (refs. 1 and 2). These weights were extrapolated by the present writer to obtain system weights for several flywheel systems sized for the Space Station, as shown in subsequent charts. Although written in 1974, the study presumes 1985 technology for composite flywheels, and an energy density of 88 watt-hours/kg for the rotor. The total system weight is about three times the rotor weight. This particular double gimbaled CMG system with composite flywheel was not actually built. The safety containment weight, if any, may be optimistic. Each wheel will deliver 5.0 kW-hr, which is about the size needed for the Space Station. Each wheel, at full RPM, has 16,000 ft-lb-sec of momentum, which is much more than the 2,200 ft-lb-sec rotor used on Skylab. Magnetic bearings were included.

### INTEGRATED POWER/ATTITUDE CONTROL SYSTEM

#### SYSTEM CAPABILITY (THREE WHEELS)

3-UNIT ARRAY SIZED FOR 20KW AVG TO BUS

ANGULAR MOMENTUM AVAILABLE FOR CONTROL > 24,000 FT-LB-SEC. (3 WHEELS) AT 50% RPM

ATTITUDE CAPABILITY - ALL INERTIAL MODES, ALL POP/LV MODES

WATT-HRS ~ 20 KW-HR TOTAL ~ 15 KW-HR USABLE ~ BETWEEN 50% & 100% RPM

#### UNIT CHARACTERISTICS (ONE WHEEL)

##### ROTOR

WATT-HRS @ MAX SPEED  $\frac{6,667}{32} \times 75\% = 5.0 \text{ KW-HR}$  (USEFUL)

DIAMETER 32 IN

WEIGHT 167 LBS

MAX SPEED 21,000 RPM  
*H ~ AVAILABLE FOR CONTROL 8,000 FT-LB-SEC*  
*H ~ TOTAL AT MAX. RPM 16,000 FT-LB-SEC*

##### MOTOR-GENERATOR

TYPE - PM - BRUSHLESS DC

RATED POWER 6,666 WATTS = 6.7 KW

VOLUME 170 IN<sup>3</sup>

##### MECHANICAL DESIGN

MAG SUSPENSION - ACTIVE AXIAL - PASSIVE RADIAL

DOUBLE GIMBALED

OUTPUT TORQUE - 125 FT-LB EACH AXIS

#### COMPOSITE/FIBRE ROTOR

##### UNIT WEIGHT BREAKDOWN

ROTOR BODY	167
SHAFTS	9
BEARINGS	32
MOTOR/GEN	92
HOUSING	88
GIMBAL	23
GIMBAL DRIVES	50
GIMBAL SENSORS	10
ELECTRONICS	20
<b>UNIT TOTAL</b>	<b>491 LBS</b>

*1/3 of Array = 516 LBS*

*ENERGY DENSITY OF ROTOR AT 100% OPERATING SPEED*

$$= \frac{(6667 \text{ W-H}) (2.2 \text{ KG/LB})}{(167 \text{ LB})} = 88 \frac{\text{W-HR}}{\text{KG}}$$

*= PRESSING 1985 STATE-OF-ART.*

ARRAY WEIGHT 1,547 LBS = 3 UNITS + STRUCTURE

(FROM REF. 1)

*Italic comments added by  
 Frank M. Elam  
 NASA JSC, 1982*

## IPACS WEIGHTS FOR SPACE STATION

Four different structural designs of the Space Station were examined to determine flywheel requirements for energy, momentum, and torque. Next, using the performance of the 1974 Rockwell IPACS design (shown in a preceding chart), the number of such flywheels (without modification) necessary to achieve Space Station requirements was determined. Finally, the weight of the resultant flywheel system was located between the momentum function and the energy storage function. Two configurations had large energy requirements relative to the momentum requirement. One configuration had large momentum requirements relative to the energy requirement. The present writer therefore created a hypothetical Space Station with "equal" momentum and energy requirements, shown in one of the columns. The allocation of weight between momentum and energy was not precise. If the wheel RPM for momentum required was 28% (or 50%), then 28% (or 50%), etc., of the total weight was allocated to momentum.

For configurations where excess momentum is available (beyond that required), the use of single gimbaled CMG's (instead of double gimbaled CMG's) would save about 1/3 of the system weight. These values are shown below in parentheses.

	SPACE STATION				
	1974 RI/IPACS (COMPOSITE ROTOR) (88 WH/KG) (PER WHEEL)	BOEING PHASE A CONFIGURATION II	BOEING PHASE A CONFIGURATION III (GIANT)	AUTHOR'S HYPO- TETICAL	NASA HQS. "CDG"
NO. OF 1974 RI/IPACS WHEELS KE PER WHEEL @ 100% RPM KW-HR H PER WHEEL @ 100% RPM	1.0 6.7 16,000	6.2 6.7 16,000	12 6.7 16,000	6 6.7 16,000	11 (USE 12) 6.7 16,000
I MAX — SLUG FT <sup>2</sup> MANEUVER RATE — DEG/SEC ACCEL.— DEG/SEC <sup>2</sup>		4.7 x 10 <sup>6</sup> .10 .01	46 x 10 <sup>6</sup> .10 .01	12.5 x 10 <sup>6</sup> .10 .01	10.5 x 10 <sup>6</sup> .10 .01
KW - REQD. (DARK SIDE) KW-HR (USEABLE) (REQD.) H — REQD (100% MARGIN) FT-LB-SEC (FOR CMG ACTION) TORQUE REQD—FT-LB (MAX. AXIS)	6.7 5 8,000 125	39 28.5 16,000 820	39 28.5 150,000 7900	39 28.5 50,000 2140	75 50 50,000 1800
% OF TOTAL RPM USED FOR H REQD. % OF TOTAL WT. ALLOCATED TO H REQUIRED	50 50	16 (24)* 16 (24)*	78 78	50 50	28 (42)* 28 (42)*
TOTAL SYSTEM WT.— LB. WT. ALLOCATED TO H— LB. WT. ALLOCATED TO ENERGY STORAGE - LB	516 258 258	3,200(2133)* 508 (508)* 2,670 (1600)*	6,200 4,800 1,400	3,200 1,600 1,600	5,700 (3800)* 1,600 (1600)* 4,100 (2200)*

\* ( ) PARENTHESES SHOW VALUES FOR SINGLE GIMBAL CMG/IPACS, FOR CASES WHERE MOMENTUM FOR SINGLE GIMBAL SYSTEM IS ADEQUATE. NUMBERS NOT IN PARENTHESES ARE FOR DOUBLE GIMBAL CMG/IPACS.

## FLYWHEEL REQUIREMENTS FOR SPACE STATION

This chart contains additional parameters not shown in a previous chart above on the same topic.

(BACKUP CHART)	1974 RI/IPACS TRIAD (COMPOSITE ROTOR)	SPACE STATION BOEING PHASE A STUDY CONFIGURATION		SPACE STATION -HYPOTHETICAL -BY WRITER	NASA HQS. "CDG" SPACE STATION
		II	III (GIANT)		
NO. OF 1974 RI/IPACS WHEELS	3	6.2	12	6	11 (Use 12)
NO. OF 1974 RI/IPACS TRIADS	1	2.06	4	2	3.7(Use 4)
SPACECRAFT INERTIAS					
$I_x \sim \text{Slug-Ft}^2$		$4.3 \times 10^6$	$4.2 \times 10^7$	$1.25 \times 10^7$	$2.8 \times 10^6$
$I_y$		$4.7 \times 10^6$	$4.5 \times 10^7$	$1.4 \times 10^7$	$9.0 \times 10^6$
$I_z$		$1.8 \times 10^6$	$4.6 \times 10^7$	$0.5 \times 10^7$	$10.5 \times 10^6$
$\dot{\theta}_y \sim \text{Maneuver Rate} \sim \text{Deg/Sec}$		0.10	0.10	0.10	0.10
$HM \sim \text{Maneuver H} - I_x \dot{\theta}_y \sim \text{Ft-Lb-Sec}$		8,000	75,000	25,000	18,300
$1/2 HM_{CG} \sim Y\text{-POP, Inertial-Cyclic}$		3,000	3,400	9,300	8,000
$H - \text{Reqd. (No Margin)} \sim \text{Ft-Lb-Sec}$		11,000	79,000	34,000	25,000
$H - \text{Reqd. (W/Margin)} \sim \text{Ft-Lb-Sec}$		16,000	150,000	50,000	50,000
Total H @ 100% RPM $\sim \text{Ft-Lb-Sec}$	48,000	100,000	192,000	100,000	178,000
RPM Range Avail. for H $\sim \%$	0-50	0-50	0-78	0-50	0-50
$H_A$ Available H $\sim \text{Ft-Lb-Sec}$	24,000	50,000	150,000	50,000	90,000
RPM Range Req'd for H $\sim \%$	0-50	0-16	0-78	0-50	0-28
$H_R$ Req'd H $\sim \text{Ft-Lb-Sec}$	24,000	16,000	150,000	50,000	50,000
Ratio $\sim H_{\text{Avail}} \div H_{\text{Reqd.}}$	1.00	3	1.00	1.00	1.8 (1.2)
$KW \sim \text{Light Side of Orbit (R eqd)}$	--	50	50	50	75
$KW \sim \text{Dark Side of Orbit (Reqd)}$	20	39	39	39	75
$\Delta KE \sim \text{Required Storage-Output} \sim KW \cdot HR$	14	28.5	28.5	28.5	50
Total KE @ 100% RPM $\sim KW \cdot HR$	20	41	80.4	41	73
% of Total KE Req'd as Useful KE	75	75	40	75	75
RPM Allocated for Useful $\Delta KE \sim \%$	50-100	50-100	78-100	50-100	50-100
Useful $\Delta KE$ As Stored $\sim KW \cdot HR$	15	30.8	30.8	30.8	55
Useful $\Delta KE$ Gen. Output $\sim KW \cdot HR$	14	28.5	28.5	28.5	50
Total System Weight $\sim \text{Lb}$	1547	3,200	6,200	3,200	5700 (3800)*
WT. $\sim$ Allocated to H $\sim \text{Lb}$	774	508	4,800	1,600	1600 (1900)*
WT. $\sim$ Allocated to KE $\sim \text{Lb}$	774	2,670	1,400	1,600	4100 (1900)*

\* ( ) - Parentheses Indicate Single Gimbal CMG/IPACS

## MOMENTUM BUILDUP FROM VARIOUS SOURCES

This chart was taken from reference 3 (by permission) to illustrate the momentum buildup from various sources. This chart was based on a Space Station inertial tensor with principal moments of inertia of:

$$\begin{aligned}
 I_X &= 10 \times 10^6 \quad (30 \times 10^6 \text{ with Orbiter docked}) - \text{slug-ft}^2 \\
 I_Y &= 8 \times 10^6 \quad (32 \times 10^6 \text{ " " " "}) - \text{" " " " } \\
 I_Z &= 4 \times 10^6 \quad (8 \times 10^6 \text{ " " " "}) - \text{" " " " }
 \end{aligned}$$

This structural design is about the same size as the "Boeing Phase A Configuration III - Giant" shown in the preceding chart, where the momentum requirement of 150,000 ft-lb-sec was selected. Docking attitude and docking transients will probably require RCS usage. Worst case LVLH attitude hold for long periods should be avoided. CMG weights shown here apparently are based on the Skylab-type designs which use relatively low rotor RPM metal rim flywheels, and do not highly stress the flywheel material.

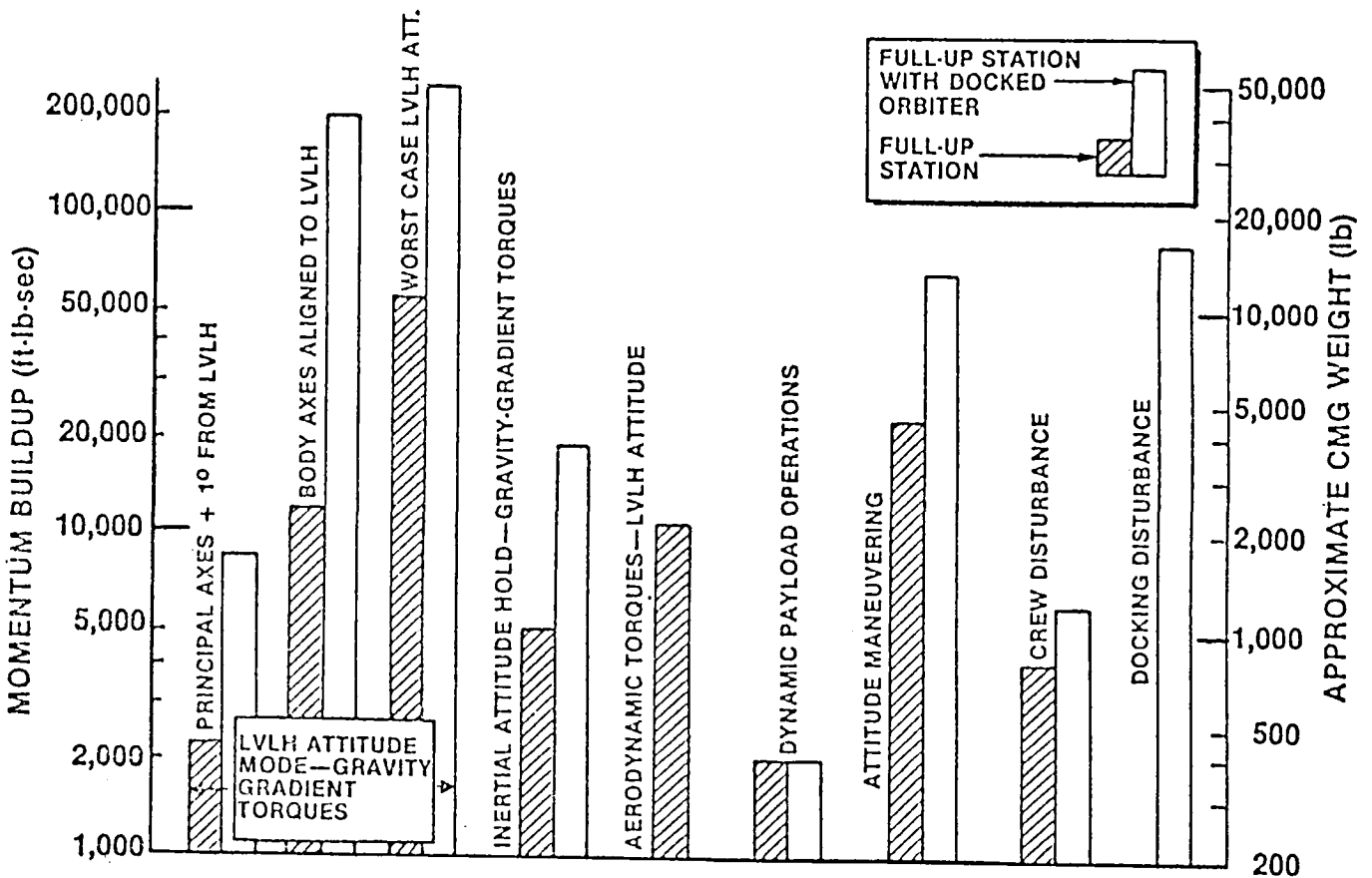

## EFFECT OF EFFICIENCY ON SOLAR ARRAY SIZE

This chart was redrawn from reference 4. The flywheel efficiency for overall input-output of 85% considers only motor-generator and magnetic bearing efficiency, ignoring the power conversion between DC and AC, which should probably have been included to yield an overall lower efficiency in the 70% to 80% range. The main point is that improved efficiency of the energy storage system can reduce solar array size and solar array weight and cost. Smaller solar arrays also reduce aero torques and aero drag, which in turn reduces RCS fuel consumption.

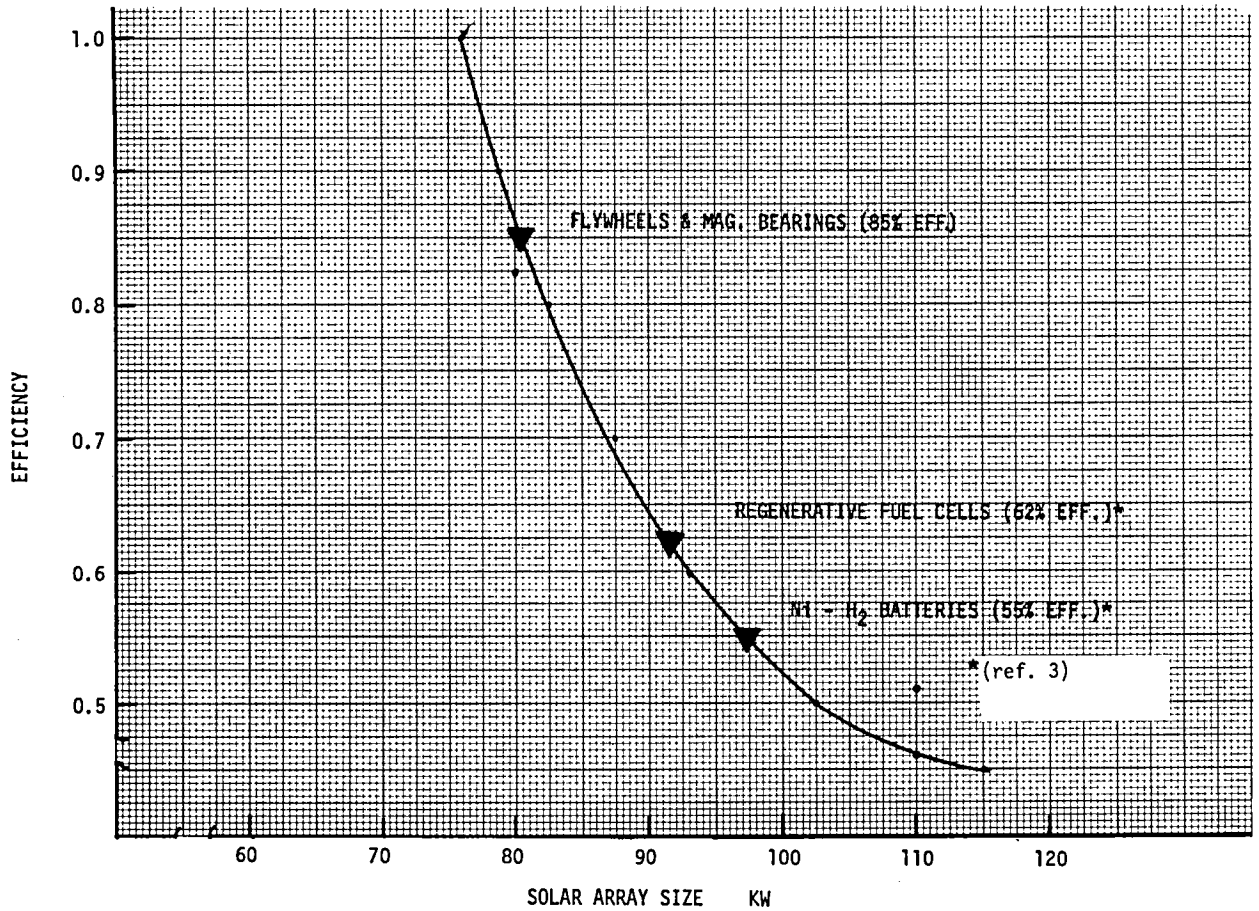

ALTERNATE ENERGY STORAGE AND WEIGHTS  
(FOR SPACE STATION)

This chart compares parameters for batteries, regenerative fuel cells, and IPACS type flywheels. One factor is that batteries (and their weight) must be replaced each four years, the fuel cells must be replaced each seven years, but the flywheels need not be replaced during the ten-year life of the space station. The resultant weight comparisons are that the flywheel system is six times lighter than the regenerative fuel cells and 11 to 22 times lighter than the batteries. Even though the method of estimating flywheel system weight is admittedly only approximate, these weight ratios are very favorable for flywheels. It is noted, however, that weights for space station equipment are not considered to be as critical a consideration as for the Space Shuttle or for aircraft in general, since the equipment weight applies to a ten-year life and affects only a relatively few of the Space Shuttle cargo trips. Weight, for example, does not affect aero drag of the space station.

	NI-CAD <u>BATTERIES</u>	NI - H <sub>2</sub> <u>BATTERIES</u>	H <sub>2</sub> - O <sub>2</sub> <u>FUEL CELLS</u>	IPACS FLYWHEELS (COMP. ROTOR-MAG BEARINGS)
LIFETIME (10 YR) WEIGHT DUE TO ENERGY STORAGE**	36,000	17,400	9,600	1,600* (ENERGY ONLY)
WT. RATIO LB/LB**	22	11	6	1
SYSTEM WT - LBS INSTALLED	12,000	5,800	4,800	3,200 (CMG + ENERGY)
STORAGE EFFICIENCY - PERCENT (TOTAL SYSTEM)	62	55	62	85
RESUPPLY DOUBLING WEIGHT TIME-YEARS	4	4	7	NEVER

BASED ON: 28.5 KW-HR (USEFUL), 39.2 KW RATE, 50,000 FT-LB-SEC AVAILABLE FOR CONTROL

\* ALLOCATING 1/2 OF IPACS WEIGHT TO ENERGY FUNCTION AND 1/2 TO CMG FUNCTION.

\*\* WTS. AND WT. RATIO DO NOT INCLUDE EFFECT OF EFFICIENCY ON SOLAR ARRAY OR ORBIT DRAG,  
NOR RCS FUEL FOR DRAG AND AERO TORQUE DUE TO SOLAR ARRAY.

## IPACS ADVANTAGES OVER BATTERIES AND REGENERATIVE FUEL CELLS

The next two charts list the advantages of IPACS type flywheel systems over batteries and regenerative fuel cells. Additional development for the composite flywheel is required to assure dimensional stability over the projected 15-year life.

### ADVANTAGES OVER BATTERIES AND REGENERATIVE FUEL CELLS

- WEIGHT ADVANGAGE
- SUPERIOR STORAGE EFFICIENCY
  - REDUCES SIZE OF SOLAR ARRAY AND ITS COST
  - REDUCES AERO-DRAG AND ORBIT MAKE-UP FUEL
- 15-YEAR LIFETIME
- TODAY'S TECHNOLOGY - COMPOSITE FIBRE/EPOXY ROTOR & MAGNETIC BEARINGS
- COMBINES ENERGY STORAGE WITH BASELINED CONTROL MOMENT GYROS (ATTITUDE CONTROL)
- NO EXTRA MAINTENANCE THAN BASELINED CMG'S
- NO REPLACEMENT REQUIRED DURING 10 YR SPACE STATION LIFE
- CMG FUNCTION - REDUCES RCS PROPELLANT, AVOIDS RCS CONTAMINATION
- EXTREMELY HIGH POWER RATES ARE FEASIBLE FOR DRIVING ELECTRO-MECHANICAL ACTUATORS OR ELECTRICAL IMPULSES (LASERS)
- ADVANTAGE OVER PRESENT BASE-LINE IN
  - A. DOLLARS
  - B. WEIGHT
  - C. RELIABILITY
  - D. SAFETY
  
- DESIGN CONSIDERATIONS
  - BEARING DESIGN - TECHNOLOGY EFFORT REQUIRED
    - IF USE MAGNETIC BEARING, SIDELOAD IS DIFFICULT
    - IF USE BALL BEARING, LIFE AND FRICTION MUST BE IMPROVED
  - RESONANCE AT CERTAIN SPEEDS AND VIBRATION (NOISE) REQUIRE CAREFUL DESIGN
  
- DISADVANTAGES
  - DEVELOPMENT BEHIND REGENERATIVE FUEL CELLS

## REFERENCES

1. Notti, G. E.; Cormack, A. III; and Schmill, W. C.: Integrated Power/Attitude Control System (IPACS) Study. Vol. I - Feasibility Studies. NASA CR-2383, April 1974.
2. Notti, J. E.; Cormack, A. III; Schmill, W. C.; and Klein, W. J.: Integrated Power/Attitude Control System (IPACS) Study. Vol. II - Conceptual Designs. NASA CR-2384, April 1974.
3. Oglevie, R. E.: Space Station Attitude Control - Challenges and Options. Presented at Annual Rocky Mountain Guidance and Control Conference, paper no. AAS-83-066, 1983.
4. Gross, Sidney: Analysis of Regenerative Fuel Cells. Rept. No. D180-27160-1, Boeing Aerospace Corp., Nov. 1982.



**Page intentionally left blank**

COMBINED ATTITUDE CONTROL

AND

ENERGY STORAGE

Henry Hoffman  
NASA Goddard Space Flight Center  
Greenbelt, Maryland

A single wheel will provide only one function such as energy storage.  
In the process, it will cause serious attitude control problems.

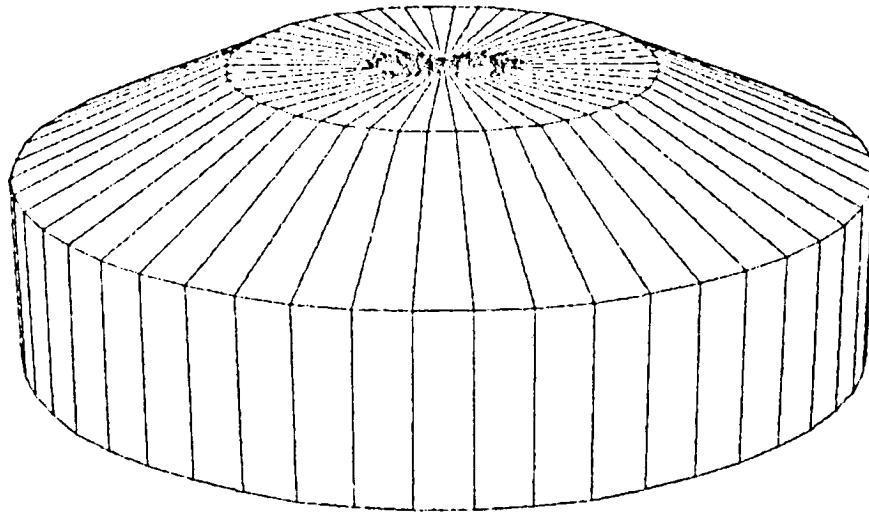

**SINGLE WHEEL  
ENERGY STORAGE ONLY**

By adding a second counter rotating wheel, it is possible to provide energy storage without disturbing the attitude control system. But since two wheels will provide control of two functions, it is now possible to provide single axis attitude control essentially for free in addition to the energy storage function.

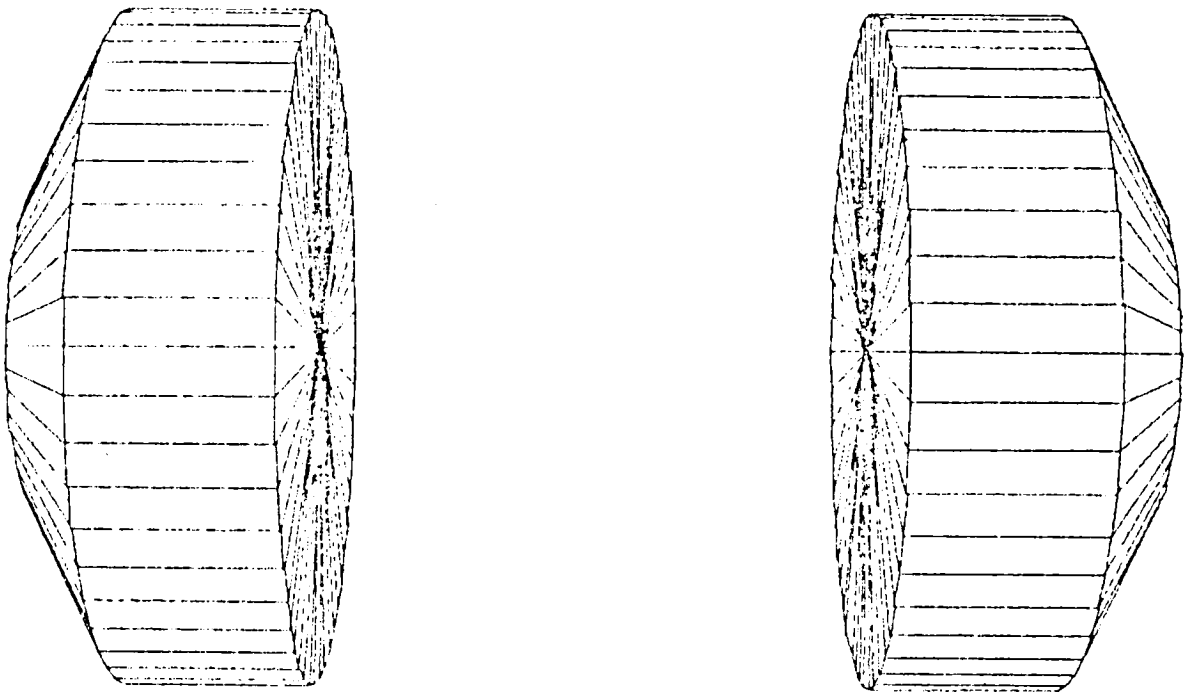

**DUAL WHEEL  
ENERGY STORAGE PLUS POSSIBLE SINGLE  
AXIS CONTROL**

Three wheels with their spin axes in a plane and nonparallel will provide three functions such as energy storage plus two axes of attitude control.

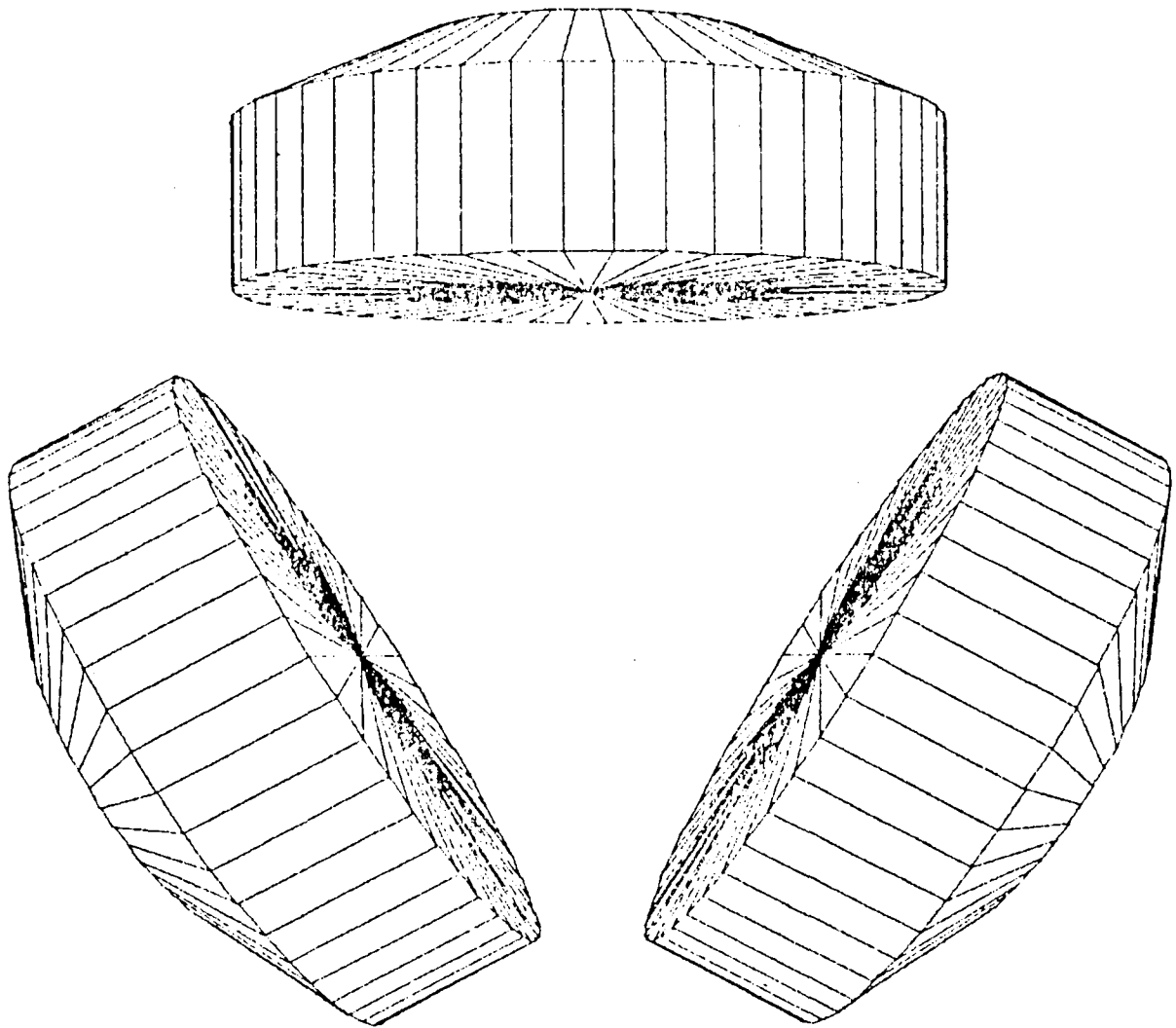

**3 WHEELS  
ENERGY STORAGE PLUS 2 -AXIS CONTROL**

Four wheels with no two axes parallel will provide four functions. This will yield the capability of energy storage plus full three axis attitude control. The addition of more wheels will add capacity to the energy storage and provide an overdetermined system which can sustain any number of failures and still be operational (full control plus energy storage) until only four wheels remain.

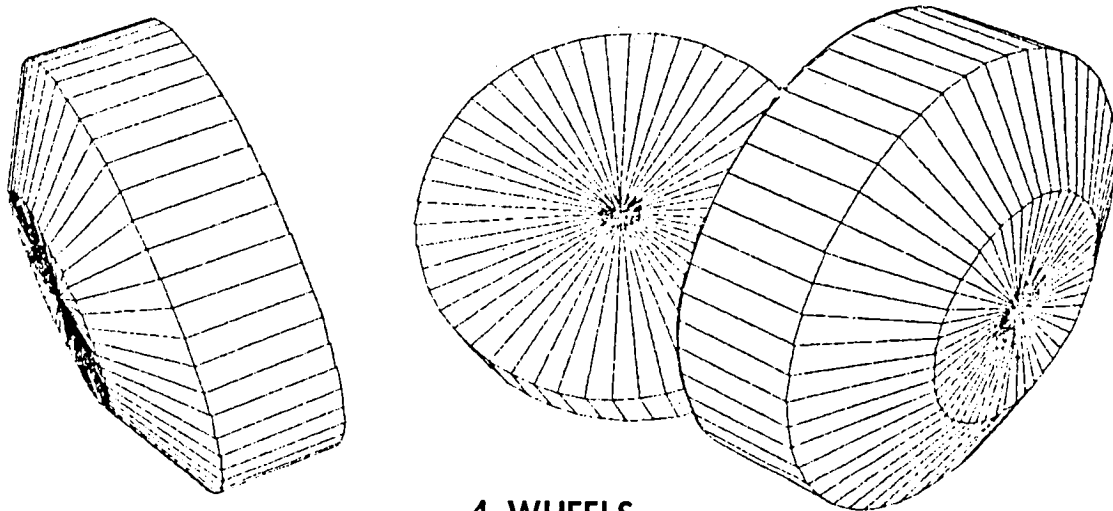
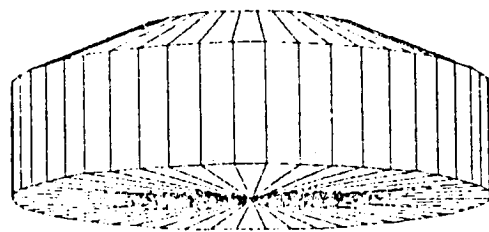

**4 WHEELS**

**ENERGY STORAGE PLUS FULL 3-AXIS CONTROL**

Let  $\vec{M}_1$ ,  $\vec{M}_2$ ,  $\vec{M}_3$ , and  $\vec{M}_4$  be unit vectors representing the orientations of 4 momentum wheels spinning at rates  $\omega_1$ ,  $\omega_2$ ,  $\omega_3$ , and  $\omega_4$ , respectively. If a net wheel torque  $T$  is required, then we want  $T_1\vec{M}_1 + T_2\vec{M}_2 + T_3\vec{M}_3 + T_4\vec{M}_4 = T$ .

In terms of the direction cosines of the unit vectors, this can be written as

$$\begin{pmatrix} x_1 & x_2 & x_3 & x_4 \\ y_1 & y_2 & y_3 & y_4 \\ z_1 & z_2 & z_3 & z_4 \end{pmatrix} \begin{pmatrix} T_1 \\ T_2 \\ T_3 \\ T_4 \end{pmatrix} = \begin{pmatrix} T_x \\ T_y \\ T_z \end{pmatrix}$$

If we also want control of the total kinetic energy of the set of wheels, we require  $\omega_1 T_1 + \omega_2 T_2 + \omega_3 T_3 + \omega_4 T_4 = \dot{E}$ .

The torque desired on each wheel can now be determined by solving the system of equations

$$\begin{pmatrix} x_1 & x_2 & x_3 & x_4 \\ y_1 & y_2 & y_3 & y_4 \\ z_1 & z_2 & z_3 & z_4 \\ \omega_1 & \omega_2 & \omega_3 & \omega_4 \end{pmatrix} \begin{pmatrix} T_1 \\ T_2 \\ T_3 \\ T_4 \end{pmatrix} = \begin{pmatrix} T_x \\ T_y \\ T_z \\ \dot{E} \end{pmatrix}$$

If redundancy is desired, any number of extra wheels may be added. The resulting equations would be as follows:

$$\begin{pmatrix} x_1 & x_2 & x_3 & \dots & x_n \\ y_1 & y_2 & y_3 & \dots & y_n \\ z_1 & z_2 & z_3 & \dots & z_n \\ \omega_1 & \omega_2 & \omega_3 & \dots & \omega_n \end{pmatrix} \begin{pmatrix} T_1 \\ T_2 \\ T_3 \\ \cdot \\ \cdot \\ \cdot \\ T_n \end{pmatrix} = \begin{pmatrix} T_x \\ T_y \\ T_z \\ \dot{E} \end{pmatrix}$$

This would allow for the failure of one or more wheels and still maintain a fully operational system as long as at least 4 wheels remained.

IPACS ATTITUDE CONTROL TECHNOLOGY CONSIDERATIONS

L. Brandon

Marshall Space Flight Center

Huntsville, Alabama



## IPACS BANDWIDTH ACCOMMODATION

Previous analyses, in-house and contracted, have indicated that an early orbiting facility such as a Space Platform (12-15 kW) would have a control bandwidth of around 0.5 hertz. As larger facilities are considered or as the Space Station and its evolutionary versions are considered the control bandwidth will evolve to lower values, probably in the 0.01 to 0.1 hertz range.

Based on the Skylab ATM CMG performance, we can expect an IPACS unit that incorporates conventional mechanical bearings to have a bandwidth of 4-10 hertz. If the IPACS unit incorporates the advanced technology magnetic bearing, a bandwidth of 1-2 hertz is expected.

In the case of the Space Station or even the Space Platform, either of the above IPACS concepts should be adequate.

- O EARLY SPACE STATION MAY REQUIRE UP TO 0.5 Hz CONTROL LOOP
- O EVOLUTIONARY SPACE STATION CONTROL REQUIREMENTS WILL PROBABLY LEAD TO LOWER CONTROL LOOP FREQUENCY (.01 Hz-.1 Hz)
- O SKYLAB CMG HAD 4-10 Hz BANDWIDTH
- O IPACS WITH CONVENTIONAL BEARINGS SHOULD HAVE BANDWIDTH SIMILAR TO SKYLAB CMG
- O IPACS WITH MAGNETIC BEARINGS WILL RESULT IN LOWER BANDWIDTH, PROBABLY NO GREATER THAN 2 Hz
- O IPACS WITH CONVENTIONAL OR MAGNETIC BEARINGS IS ADEQUATE FOR SPACE STATION

## CONTROL LAW

A control law was developed during the Skylab activity which should have direct application to the IPACS/Space Station. The law handles any number of CMG's, does not require a particular value of momentum and accommodates a variable momentum magnitude.

Since the variability of the momentum vector is somewhat predictable (i.e., power usage/power schedules), the law might be optimized. A particular initialization and configuration of the IPACS units would be worked out in a much later phase of Space Station development after Station configuration, orientation, and requirements are firmed up.

- O A CONTROL LAW ALREADY DEVELOPED ASSUMING VARIABLE H
- O THE EXISTING LAW DOES NOT REQUIRE ANY PARTICULAR H MAGNITUDE
- O SOME OPTIMIZATION PROBABLY NEEDED SINCE POWER CHARGE/DISCHARGE IS PREDICTABLE
- O PARTICULAR CONFIGURATION, INITIALIZATION WOULD BE WORKED OUT DEPENDING ON DESIRED MOMENTUM ENVELOPE CHARACTERISTICS

## DGCMG VERSUS REACTION WHEEL

The double gimbal CMG lends itself to control applications where large cyclic momentum disturbances are expected as in the case of the Space Station. A reaction wheel has to accommodate such disturbances by a large variation in wheel speed which tends to drive the torquer into nonlinear regions. When the additional problem of having large wheel speeds for energy storage is considered, the reaction wheel design becomes an even greater concern.

When large control torque requirements occur, as expected for the Space Station, the reaction wheel torquer is driven by the control requirement rather than the power charge/discharge requirement whereas in the DGCMG the size of the wheel motor is driven by the power requirement.

Finally, the CMG gimbal torquer is of modest design to obtain necessary torques, requiring, in fact, a slower gimbal rate than was needed for the Skylab CMG.

- O CYCLIC AND SECULAR MOMENTUM EASILY MANAGED BY DGCMG
- O CONTROL TORQUE NON-LINEARITIES THAT WOULD OCCUR WITH LARGE SPEED VARIATION OF RW NOT A CONCERN WITH DGCMG
- O CONCERN OF OBTAINING CONTROL TORQUE OF HIGH VALUE WITH REACTION WHEELS - MOTOR SIZE MAY BE PROHIBITIVELY LARGE TO OBTAIN SIGNIFICANT TORQUE WITH WHEEL AT 35,000 RPM

$$T = I \alpha \quad (\text{REACTION WHEEL})$$

$$\text{IF } I = 5 \text{ N.M.S}^2$$

$$\text{AND } T = 150 \text{ N.M}$$

$$\text{THEN } \alpha = 30 \text{ RAD/SEC/SEC} \approx 300 \text{ RPM/SEC}$$

$$\text{NORMAL POWER DISCHARGE } \alpha = 7 \text{ RPM/SEC} \quad (35,000 \text{ TO } 17,500 \text{ RPM IN } 40 \text{ MINUTES})$$

- O CMG GIMBAL REQUIREMENTS

$$T = \dot{H} = H \dot{\phi}$$

$$\text{IF } H = 9000 \text{ N.M.S}$$

$$\text{AND } T = 150 \text{ N.M}$$

$$\text{THEN } \dot{\phi} = 0.95 \text{ DEG/SEC} \quad (\text{GIMBAL RATE OF SKYLAB CMG IS } \sim 3 \text{ DEG/SEC})$$

- WHEEL SPEED VARIATION
  - MINIMUM WHEEL SPEED EXCEEDS CONTROL REQUIREMENTS FOR MOMENTUM AND TORQUE
  - CMG STIFFNESS TYPICALLY 4-10 Hz FOR SKYLAB TYPE CMG; MAGNETIC BEARING MAY BE LOWER BUT ADEQUATE FOR SPACE STATION (.5 Hz)
  - CONTROL LAW EXISTS THAT INCORPORATES VARIABLE H
- COMPLEXITY
  - DOES NOT OFFER CONTROL SUBSYSTEM AN ADVANTAGE
  - SOFTWARE MORE COMPLEX
- IPACS IMPLEMENTATION
  - DGCMG PREFERRED OVER SGCMG OR REACTION WHEEL
  - CONTROL TORQUE AT HIGH SPEED OF WHEEL MAY BE LIMITED WITH RW'S
  - MANAGEMENT OF CYCLIC AND SECULAR MOMENTUM SIMULTANEOUSLY WITH POWER MANAGEMENT EASIER WITH CMG
  - REACTION WHEELS WOULD REQUIRE SPIN/DESPIN IN PAIRS DURING ENERGY STORAGE/DISCHARGE
- POWER/CONTROL INTERACTION
  - POWER USAGE WILL BE AN ADDITIONAL DISTURBANCE SOURCE TO ATTITUDE CONTROL
  - LARGE MOMENTUM WILL REQUIRE FINER CONTROL ON GIMBAL RATE TO MAINTAIN SMALL TORQUE INCREMENTS
- LIFETIME
  - CONVENTIONAL CMG WITH MECHANICAL BEARINGS OPERATING AT 8000-9000 RPM HAS ADEQUATE LIFETIME
  - IPACS WITH MECHANICAL BEARINGS OPERATING AT 20,000-35,000 RPM RESULTS IN LIFETIME CONCERN
  - IPACS WITH MAGNETIC BEARINGS MAY RESULT IN EXTENDED LIFETIME

**Page intentionally left blank**

FLYWHEEL ELECTRONICS

Frank Nola  
Marshall Space Flight Center  
Huntsville, Alabama

## REQUIREMENTS

Requirements of the system are to accelerate the momentum wheel to a fixed maximum speed when solar energy is available and to maintain a constant voltage on the spacecraft bus under varying loads when solar energy is not available.

- SOLAR POWER AVAILABLE

ACCELERATE MOMENTUM WHEEL TO 35,000 RPM

MAINTAIN CONSTANT SPEED IF EXCESS ENERGY AVAILABLE

- NO SOLAR POWER

DECELERATE WHEEL - PROVIDE ELECTRICAL ENERGY TO SPACECRAFT -  
MAINTAIN CONSTANT REGULATED SUPPLY VOLTAGE OVER VARIABLE POWER  
OUTPUT RANGE.

## IPACS

An outline of the presentation (see below) includes requirements, energy flow control, types of motors considered, type of electronic control, and efficiency considerations.

### WHEEL MOTOR - ELECTRONIC CONTROLLER

- REQUIREMENTS
- ENERGY FLOW CONTROL
- CANDIDATE MOTOR TYPES
- PULSE WIDTH MODULATION (PWM) CONTROL
- EFFICIENCY CONSIDERATIONS



## ENERGY FLOW CONTROL

This is a simplified energy flow control diagram. The motor controller senses the voltage level from the solar power source and compares it to a threshold. Voltage above the threshold indicates the availability of solar energy and the controller is switched to a speed control mode for accelerating the flywheel. Solar energy is being supplied to the IPACS and to the spacecraft in this mode. Voltage below the threshold indicates insufficient solar energy and switches the controller to a voltage control mode. In this mode, energy is being supplied to the spacecraft only by the IPACS and the voltage is held constant by the voltage feedback loop.

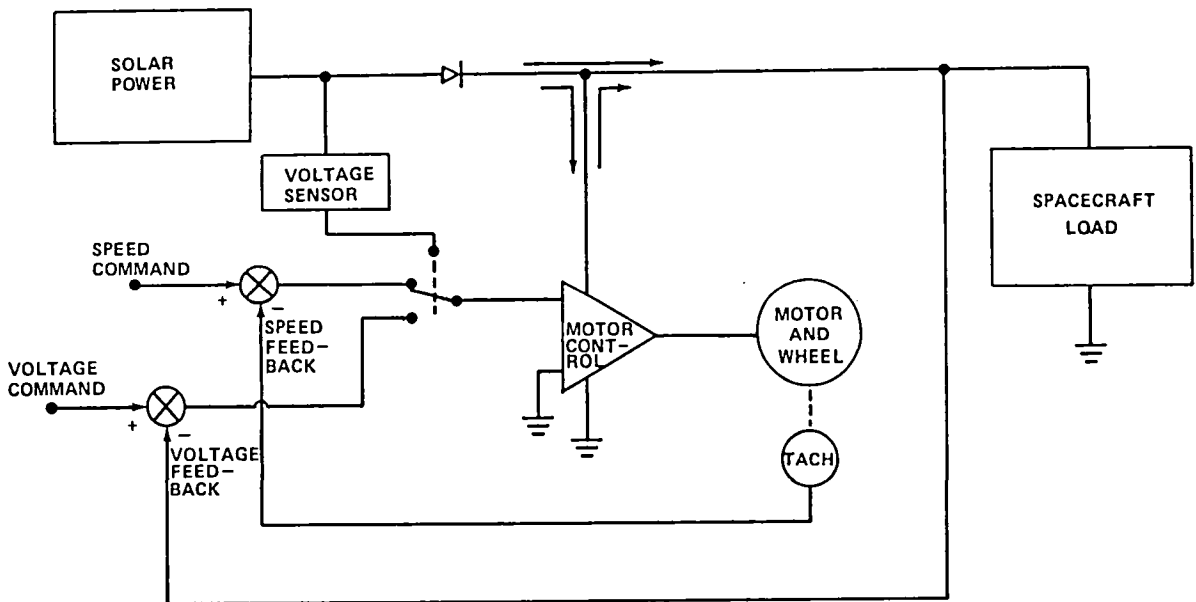

## PWM CURRENT CONTROL

Simplified diagrams show the path of current flow in the pulse width modulated (PWM) controller for both the accelerating and decelerating mode. Diagrams show how both are accomplished in a common controller. Transistor switches are either full on, dissipating very low power, or full off, dissipating no power, resulting in high efficiency.

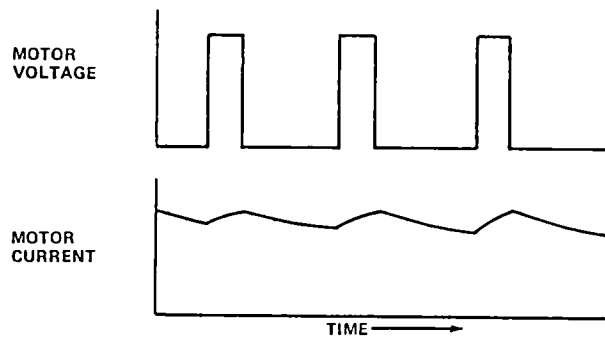
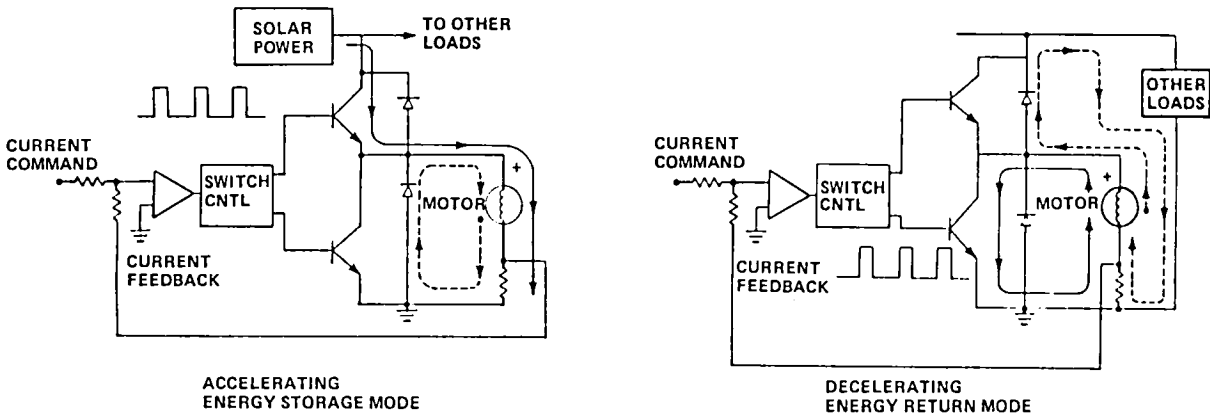

## SINUSOIDAL PWM CONTROL

Simplified diagram shows a transistor bridge for converting DC to AC and AC to DC. Also shown is how a sinusoidal output from the motor shaft position sensor is pulse width modulated to produce sinusoidal motor current. Maintaining sinusoidal current eliminates unnecessary harmonic losses.

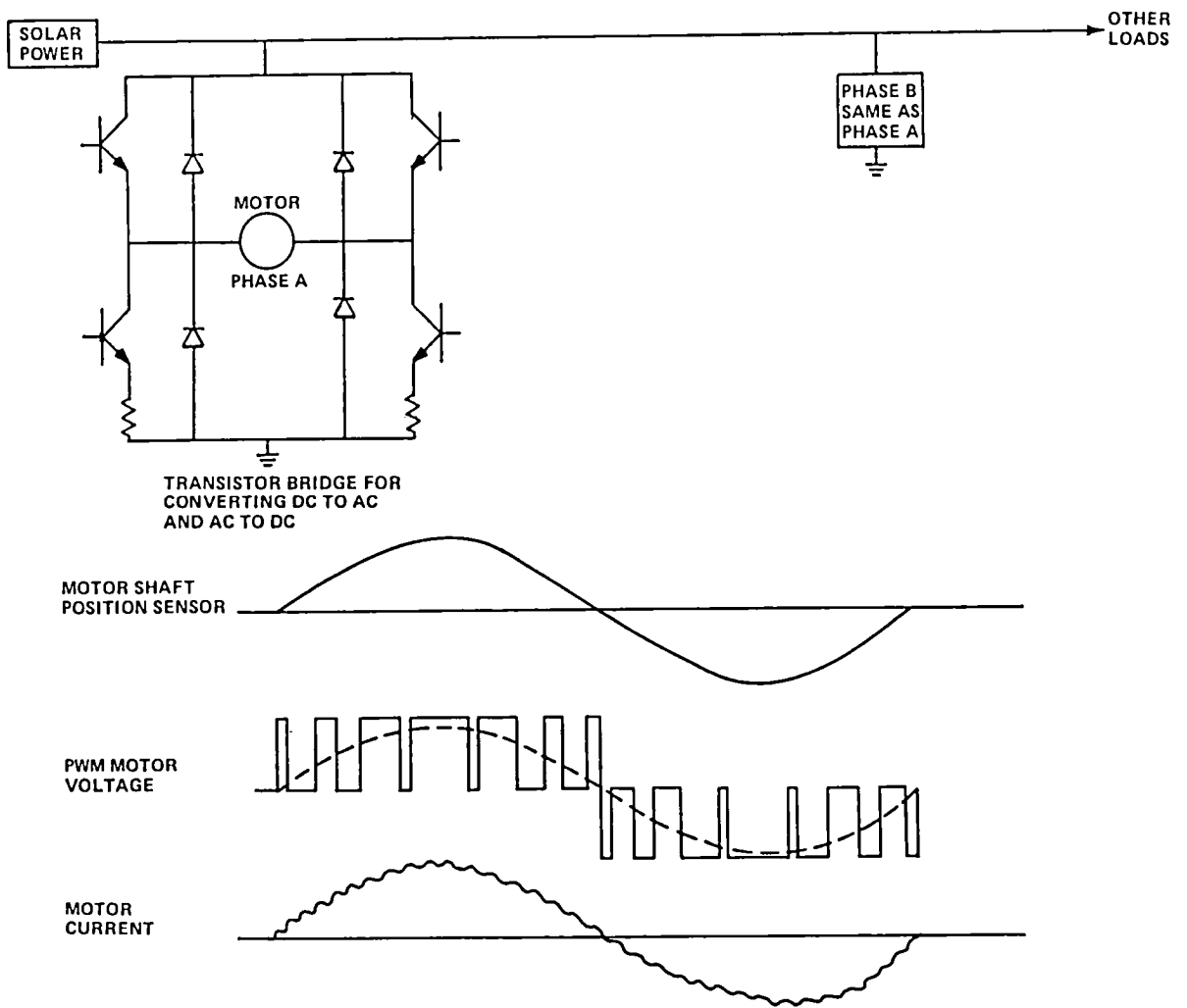

## CANDIDATE MOTOR TYPES

Candidate motor types are discussed. Permanent magnet brushless DC motors and variable frequency AC induction motors are the only two considered for IPACS. The brushless DC motor is favored because of its high torque to weight ratio and high efficiency.

- SELF SYNCHRONOUS PERMANENT MAGNET BRUSHLESS DC MOTOR
- VARIABLE FREQUENCY AC INDUCTION MOTOR
  - BOTH ARE ESSENTIALLY AC MOTORS
    - DC LINE VOLTAGE CONVERTED TO AC FOR ACCELERATION
    - AC MOTOR VOLTAGE CONVERTED TO DC FOR ENERGY RETURN
    - COMMON CONTROLLER ACCOMPLISHES BOTH/CONTROLLER ALSO REGULATES LINE VOLTAGE IN GENERATOR MODE
  - AC INDUCTION MOTOR
    - MOST RUGGED
    - REQUIRES NO POSITION SENSORS
    - REQUIRES SPEED SENSOR
  - BRUSHLESS DC MOTOR
    - HIGHEST TORQUE TO WEIGHT RATIO
    - HIGHEST EFFICIENCY
    - LESS COMPLEX CONTROLLER
    - REQUIRES ROTOR POSITION SENSORS
    - SAMARIUM COBALT MAGNETS INSURE RUGGEDNESS
    - 140 HP, 20,000 RPM MOTOR DEMONSTRATED (G.E.)

## EFFICIENCY

Sources of power loss which affect the efficiency are listed. Included are the motor, the electronic controller, and bearings.

- SOURCES OF LOSS

  - MOTOR

  - ELECTRONIC CONTROLLER

  - BEARINGS - BALL OR MAGNETIC

- MOTOR EFFICIENCY OPTIMIZED BY INCREASING WEIGHT

  - REDUCES COPPER LOSS

  - LOWER FLUX DENSITY IN IRON REDUCES CORE LOSSES

- CONTROLLER EFFICIENCY OPTIMIZED BY OUTPUT POWER OF SYSTEM AND BY LINE VOLTAGE.

  - THIS DETERMINES CURRENT CAPACITY.

- BALL BEARING LOSSES DETERMINED BY CMG PRELOAD REQUIREMENTS

- MAGNETIC BEARING LOSSES DETERMINED BY CMG STIFFNESS REQUIREMENTS.

## EFFICIENCY PARAMETERS

This chart lists the assumptions that were made to perform energy calculations on the following charts.

### ● ASSUMPTIONS

WHEEL OUTPUT POWER - 6 KW  
SPEED RANGE - 17,500 RPM TO 35,000 RPM (S)  
TWO MOTORS/CONTROLLERS PER WHEEL - 3 KW EACH ( $P_o$ )  
LINE VOLTAGE - 135 VOLT DC ( $V_1$ )  
BEARING FRICTION - 12 OZ IN (F) (6 OZ IN/MOTOR)  
MOTOR LOSSES - 3% AT 35,000 RPM, 12% AT 17,500 RPM  
SYSTEM LOSSES - 10% AT 35,000 RPM, 20% AT 17,500 RPM  
PWM FREQUENCY - 12 KHZ (F)

### OTHER SYMBOLS

$V_{ce(sat)}$  - TRANSISTOR ON VOLTAGE

t - TRANSISTOR TURN ON AND TURN OFF TIME

$\eta$  - EFFICIENCY

## EFFICIENCY SUMMARY

This chart summarizes the efficiency of the flywheels, motor, and electronic controller. The summary shows equal average charge and discharge efficiencies of 85.5 percent. The full cycle efficiency of charge and discharge is 73.1 percent.

<u>DISCHARGE</u>		<u>CHARGE</u>	
17,500 RPM	35,000 RPM	17,500 RPM	35,000 RPM
<u>81.2%</u>	<u>89.7%</u>	<u>83%</u>	<u>88%</u>
AVERAGE DISCHARGE EFFICIENCY		AVERAGE CHARGE EFFICIENCY	
<u>85.5%</u>		<u>85.5%</u>	
CYCLE EFFICIENCY - CHARGE AND DISCHARGE			
<u>73.1%</u>			

## CHARGE EFFICIENCY DISCHARGE EFFICIENCY

These charts show the calculations which determined the charge and discharge efficiencies.

- SINCE THE SPACECRAFT IS IN SUNLIGHT 1.6 TIMES LONGER THAN IN DARKNESS, THE WHEEL CAN BE ACCELERATED WITH 1.6 TIMES LESS AVERAGE POWER.

ACCELERATION POWER

$$P_a = \frac{3000}{1.6} = 1875 \text{ WATTS}$$

AT 17,500 RPM

MOTOR CURRENT (ALLOWING 15% LOSS)

$$I = \frac{P_a + .15 P_a}{.5 V_i} = \frac{1875 + .15 \times 1875}{.5 \times 135} = 32 \text{ A}$$

CONTROLLER LOSSES

$$P_c = 139 \text{ WATTS}$$

MOTOR LOSSES

$$P_m = 90 \left( \frac{32}{24.4} \right)^2 = 154 \text{ WATTS}$$

BEARING LOSS

$$P_b = 78 \text{ WATTS}$$

TOTAL LOSS

$$P_t = 139 + 154 + 78 = 371 \text{ WATTS}$$

EFFICIENCY (17,500 RPM)

$$\eta = \frac{1875}{1875 + 371} = 83\%$$

AT 35,000 RPM

MOTOR CURRENT (ALLOWING 12% LOSS)

$$I = \frac{P_a + .12 P_a}{V_i} = \frac{1875 + .12 \times 1875}{135} = 15.5 \text{ A}$$

CONTROLLER LOSSES

$$P_c = 55 \text{ WATTS}$$

MOTOR LOSSES

$$P_m = 90 \left( \frac{15.3}{24.4} \right)^2 = 37 \text{ WATTS}$$

BEARING LOSS

$$P_b = 155 \text{ WATTS}$$

TOTAL LOSS

$$P_t = 55 + 37 + 155 = 247 \text{ WATTS}$$

EFFICIENCY (35,000 RPM)

$$\eta = \frac{1875}{1875 + 247} = 88\%$$

AVERAGE CHARGE EFFICIENCY

$$\eta = \frac{83 + 88}{2} = 85.5\%$$

CYCLE EFFICIENCY - CHARGE AND DISCHARGE

$$\eta = 85.5 \times 85.5 = 73.1\%$$

AT 35,000 RPM

MOTOR CURRENT

$$I = \frac{P_o + .1 P_o}{V_i} = \frac{3000 + 300}{135} = 24.4 \text{ AMPS}$$

CONTROLLER LOSSES (STATIC + SWITCHING)

$$P_c = 4 (.637) [I \times V_{ce} (\text{SAT})] + 2 (.637) I [.5 V_i] t [2F]$$

$$P_c = 4 (.637) [24.4 \times 1.2] + 2 (.637) (24.4) [.5 \times 135] .5 \times 10^{-6} [2 \times 12 \times 10^3]$$

$$P_c = 75 + 25 = 100 \text{ WATTS}$$

MOTOR LOSSES

$$P_m = .03 P_o = .03 \times 3000 = 90 \text{ WATTS}$$

BEARING LOSS

$$P_b = F_b = 6 \times \frac{35000}{1352} = 155 \text{ WATTS}$$

TOTAL LOSSES

$$P_t = 100 + 90 + 155 = 345 \text{ WATTS}$$

EFFICIENCY (35,000 RPM)

$$\eta = \frac{P_o}{P_o + P_t} = \frac{3000}{3000 + 345} = 89.7\%$$

AT 17,500 RPM

MOTOR CURRENT

$$I = \frac{P_o T + .2 P_o}{.5 V_i} = \frac{3000 + 600}{.5 \times 135} = 53 \text{ AMPS}$$

CONTROLLER LOSSES

$$P_c = 2.53 [53 \times 1.5] + 1.27 (53) [810 \times 10^{-3}]$$

$$P_c = 201 + 54 = 255 \text{ WATTS}$$

MOTOR LOSSES

$$P_m = .12 P_o = .12 \times 3000 = 360 \text{ WATTS}$$

BEARING LOSS

$$P_b = 6 \times \frac{17,500}{1352} = 78 \text{ WATTS}$$

TOTAL LOSSES

$$P_t = 255 + 360 + 78 = 693 \text{ WATTS}$$

EFFICIENCY (17,500 RPM)

$$\eta = \frac{3000}{3000 + 693} = 81.2\%$$

AVERAGE DISCHARGE EFFICIENCY

$$\eta = \frac{89.7 + 81.2}{2} = 85.5\%$$



**Page intentionally left blank**

IPACS ELECTRONICS -  
COMMENTS ON THE ORIGINAL DESIGN  
AND  
CURRENT EFFORTS AT LaRC

Joe C. Gowdey  
NASA Langley Research Center  
Hampton, Virginia

## IPACS ORIGINAL DESIGN

As Mr. Keckler has previously described (ref. 1), the IPACS consisted, from an electro-mechanical transducer standpoint, of two permanent magnet, 2 pole, brushless D.C. motors mounted symmetrically on opposite ends of the flywheel axle. Each motor contained 2 windings at  $90^{\circ}$  to one another. The two motors were skewed from one another by  $45^{\circ}$ , thus furnishing torque vectors every  $45^{\circ}$  of rotation. The motors were designed by General Electric, who also were to furnish the power drive assembly as a hybrid chip, using bipolar technology. Rockwell, the prime contractor, was unable to utilize the chip at the required currents, and elected to produce the power drive assembly in-house. A massive Darlington transistor was used. With the inherent inability to reach saturation, which characterizes a Darlington, and the slow speed of the early technology large chip, the design suffered from excessive semiconductor losses. This is the source of the low 52 percent energy turnaround efficiency achieved by this design.

In order to achieve high efficiencies, devices of the IPACS type use very low winding resistances (this design was 0.045 ohm per winding) and depend upon Pulse Width Modulation (PWM) techniques to control currents. The major system losses, therefore, reside in the semiconductor switches used to mechanize the circuit. Modern semiconductors, in particular the power field effect transistor (PFET), can be used to great advantage if certain limitations imposed by the PFET manufacturing process are taken into account. A byproduct of the PWM technique is the ability to absorb power at any practical voltage higher than the back EMF of the motor and to produce power at any practical voltage. In other words, the PWM circuit is relatively insensitive to input voltage variations and is self regulating for output.

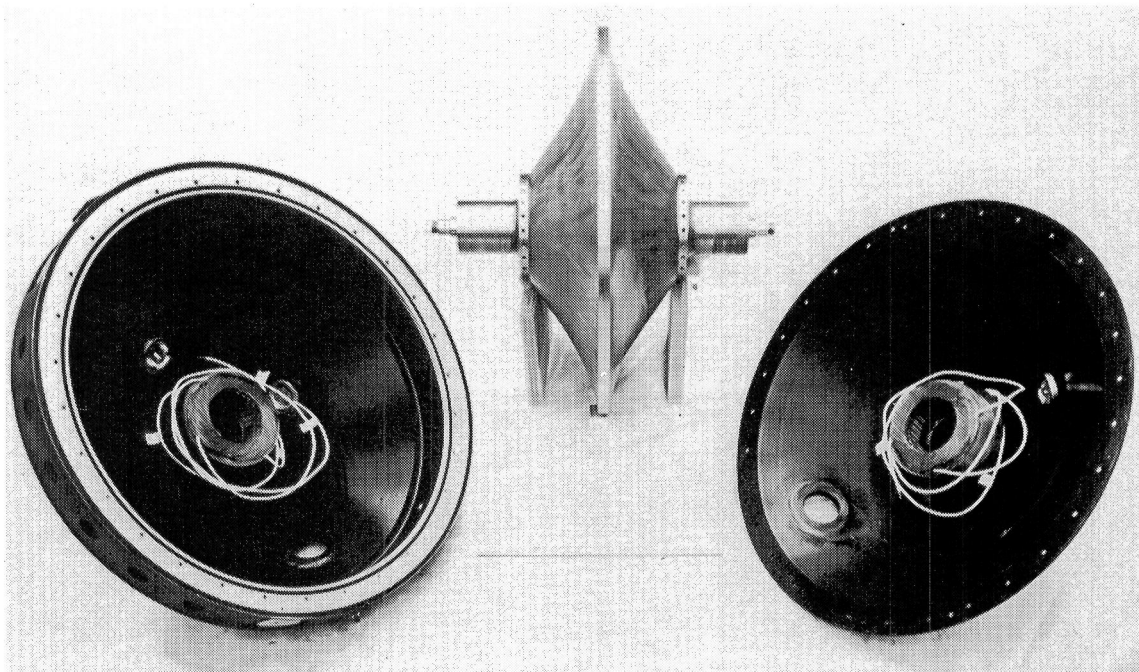

LaRC EFFORT: BASIC CIRCUIT

The four motor windings are represented by the vectors in the figure below. Each winding has a separate circuit; the figure represents one of four. The top line is the supply/output bus. The motor current in each winding is detected by a pulse type current transformer and fed to the PWM module. The upper transistors are driven by the PWM module at a 20 kHz duty rate. The lower transistors are driven at the motor rotational frequency for motor mode (power input to the flywheel) operation and are not used for generator mode operation. The transistors selected are capable of operation at up to 60 kHz, and operation at the higher frequencies may be explored. The PFET transistor contains parasitic elements which are manifested as diodes connected from source to drain. The poor characteristics of these parasitic elements necessitate the insertion of the blocking diodes in series with the PFETs. This represents another loss element for the circuit, but the loss is more than offset by the low saturation resistance and almost nonexistent drive power requirement of the PFET. Since in the H-bridge configuration the motor winding is floated, i. e., has no fixed electrical reference, provision must be made to gate the upper transistors of the bridge with a floated power supply, as shown on the upper right. Signals from the PWM module are transmitted to the gating flipflop via an optical coupler. The gating flipflop is a low impedance totempole output Schmidt trigger, which is used to square up the optical coupler signal and provide minimum gate impedance to the PFET.

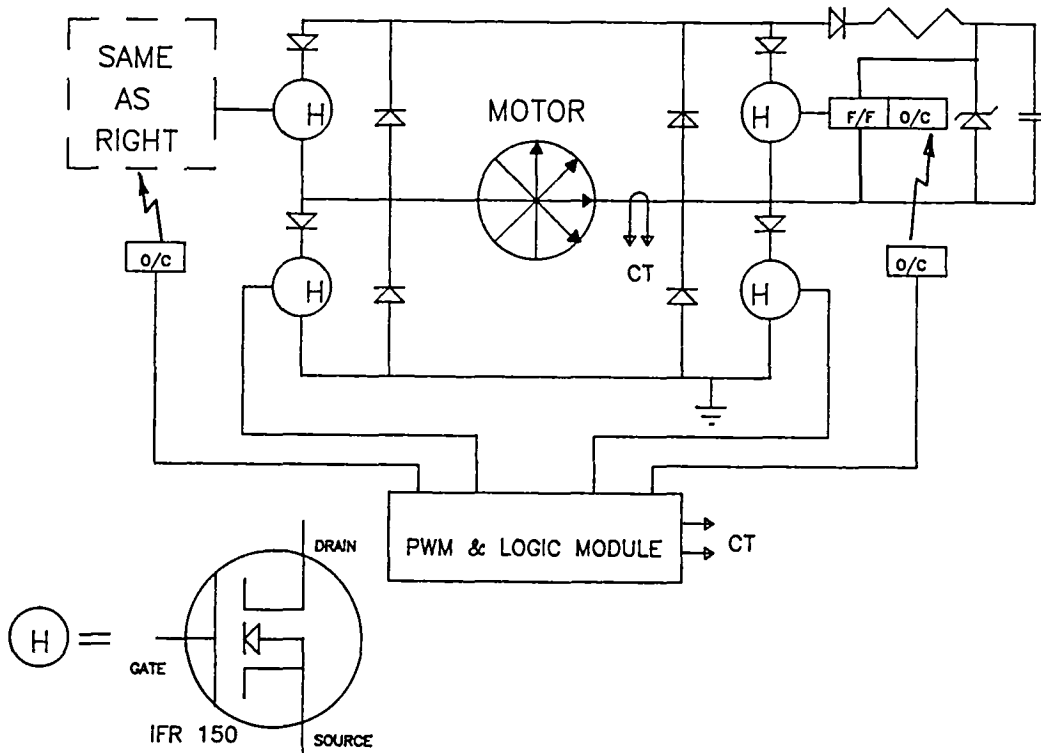

## MOTOR MODE OPERATION

During rotation, the voltage appearing at the motor terminals is a sine wave of the rotational frequency with a peak value of  $E_B$  times speed in RPM. For this motor  $E_B$  equals 1.23 MV/RPM; thus at the peak speed of 35,000 RPM, the back EMF of the motor is 43 volts peak. For the half cycle of instantaneous polarity noted, the "switches" shown in the upper right diagram are closed and current (I) flows per the arrows. When I is equal to a preset value or the PWM duty cycle expires, the upper switch opens. The winding inductance causes "freewheel" current to flow in the path shown in the lower sketch until the start of the next PWM duty cycle. The PWM duty cycle is 90 percent on a 20 KHz rate. This results in a charge cycle beginning every 50 microseconds, with a minimum freewheel time of 5 microseconds.

Because little torque is produced by currents near the  $0^\circ$  and  $180^\circ$  electrical rotor positions, the PWM is disabled from  $0^\circ$  to  $18^\circ$  and from  $162^\circ$  to  $180^\circ$ , during which time all switches are open. During the opposite half cycle of operation, the opposite PFET switches operate similarly. Note that the lower bridge transistor is on for the entire half revolution (less the blanking periods near 0 and  $180^\circ$ ).

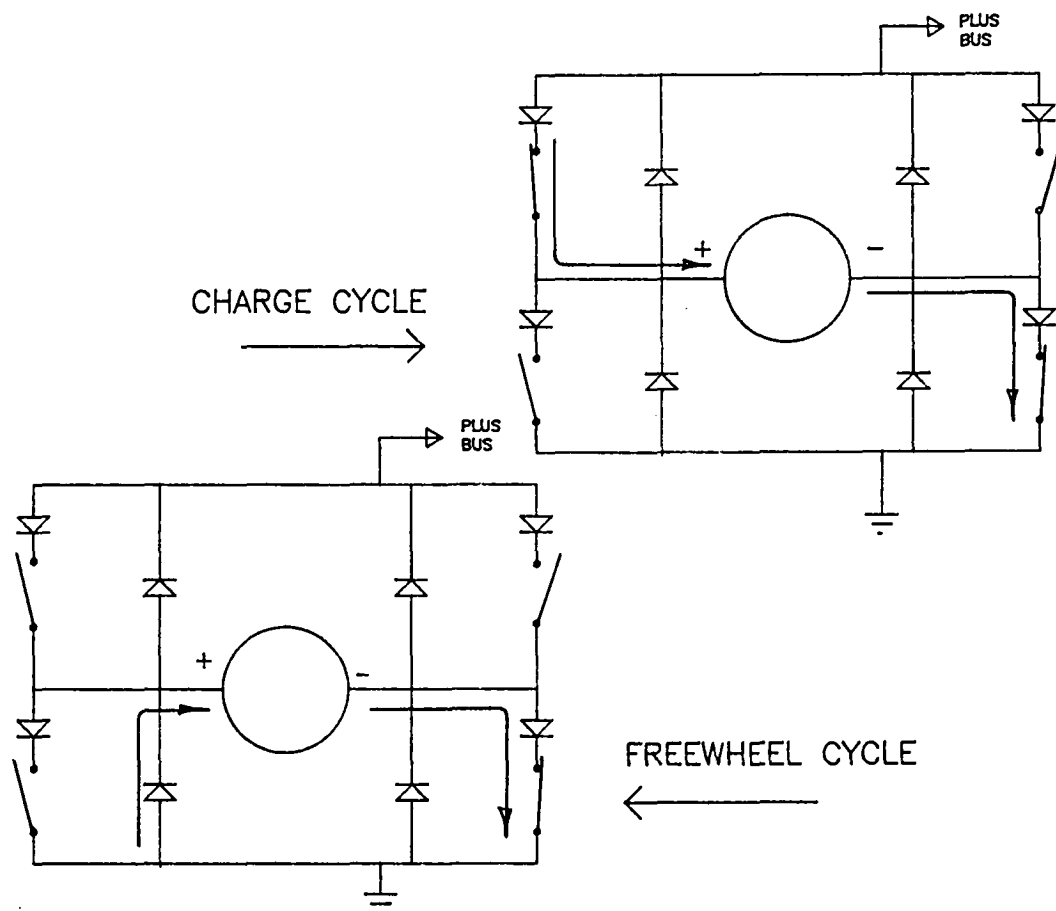

## GENERATOR MODE OPERATION

During generator mode operation, the lower bridge PFETs are disabled, and the upper PFETs are gated on simultaneously at the PWM frequency. Assuming the noted instantaneous  $E_B$  polarity as shown in the upper sketch, current flows as shown, charging the winding inductance. When the current reaches a preset value, the switches open. The winding inductance forces the current to continue flowing, raising the voltage as necessary to boost the current to the bus voltage level and drawing current from ground level, as shown in the Boost sketch. The PWM varies the duty cycle as necessary to maintain the bus voltage at the predetermined setpoint. As in motor mode, greatest efficiency is obtained if the timing is such that the current through the winding never falls to zero between successive charge cycle starts. Therefore, higher PWM frequencies may be required to optimize operation, even though higher frequencies entail higher switching losses in the PFETs. These and other possible efficiency increasing techniques remain to be explored in the IPACS hardware.

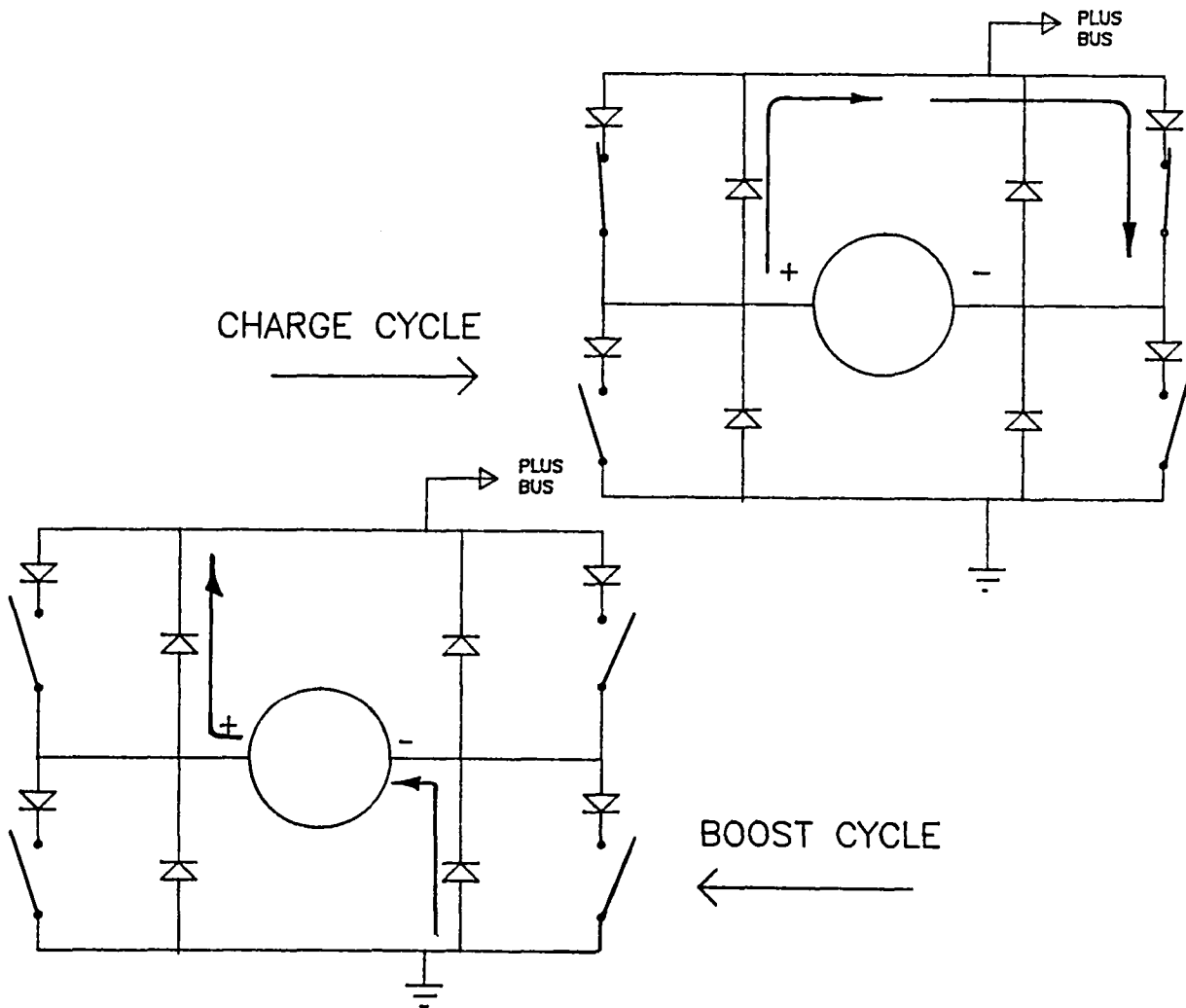

### PRESENT STATUS

The power bridge has been fabricated, and all major parts are in hand. The bridge has been tested (using a different PWM setup) with a 1/4 HP motor for another program.

The PWM, Control Logic, and upper bridge driver power supply are breadboarded and are being debugged prior to starting testing on a passive load.

The Hall sensor circuit for detecting rotor position is in design.

The above work is being done on a time available basis at Langley Research Center. Because major funding for the program was terminated several years ago, management considers the effort to have very low priority. Consequently, progress is very slow, as manpower is devoted to "more pressing" problems.

- POWER BRIDGE FABRICATED AND TESTED @ 1/8 FULL LOAD
- PWM, CONTROL LOGIC, AND UPPER BRIDGE DRIVER BREADBOARDED AND AWAITING TEST
- HALL SENSOR ROTOR POSITION CIRCUIT IN DESIGN
- IN MANPOWER LIMITED ENVIRONMENT, LOW BUDGET = LOW PRIORITY ERGO, SLOW PROGRESS

### REFERENCE

1. Keckler, C. R.: Integrated Power/Attitude Control System (IPACS). Integrated Flywheel Technology - 1983, NASA CP-2290, 1983, pp. 5-21.

ANNULAR MOMENTUM CONTROL  
DEVICE (AMCD)

Nelson J. Groom  
Langley Research Center  
Hampton, VA 23665



## SUMMARY

This presentation provides a brief discussion of the Annular Momentum Control Device (AMCD) concept, applications, and advantages (as a momentum storage device). In order to investigate any potential problem areas in implementing the AMCD concept, a laboratory test model AMCD was designed and built under contract. A description of the laboratory model AMCD and a brief overview of the results of the laboratory model test phase are also presented. The presentation concludes with a discussion of the efforts required to complete the AMCD laboratory model test phase.

## ANNULAR MOMENTUM CONTROL DEVICE (AMCD) CONCEPT

The basic concept of the AMCD is that of a rotating annular rim suspended by noncontacting magnetic bearings and driven by a noncontacting electromagnetic spin motor (Fig. 1). A detailed discussion of the rationale for the AMCD configuration and some of its potential applications are presented in Reference 1.

- MAGNETICALLY SUSPENDED ROTATING RIM POWERED BY A NONCONTACTING ELECTROMAGNETIC SPIN MOTOR.

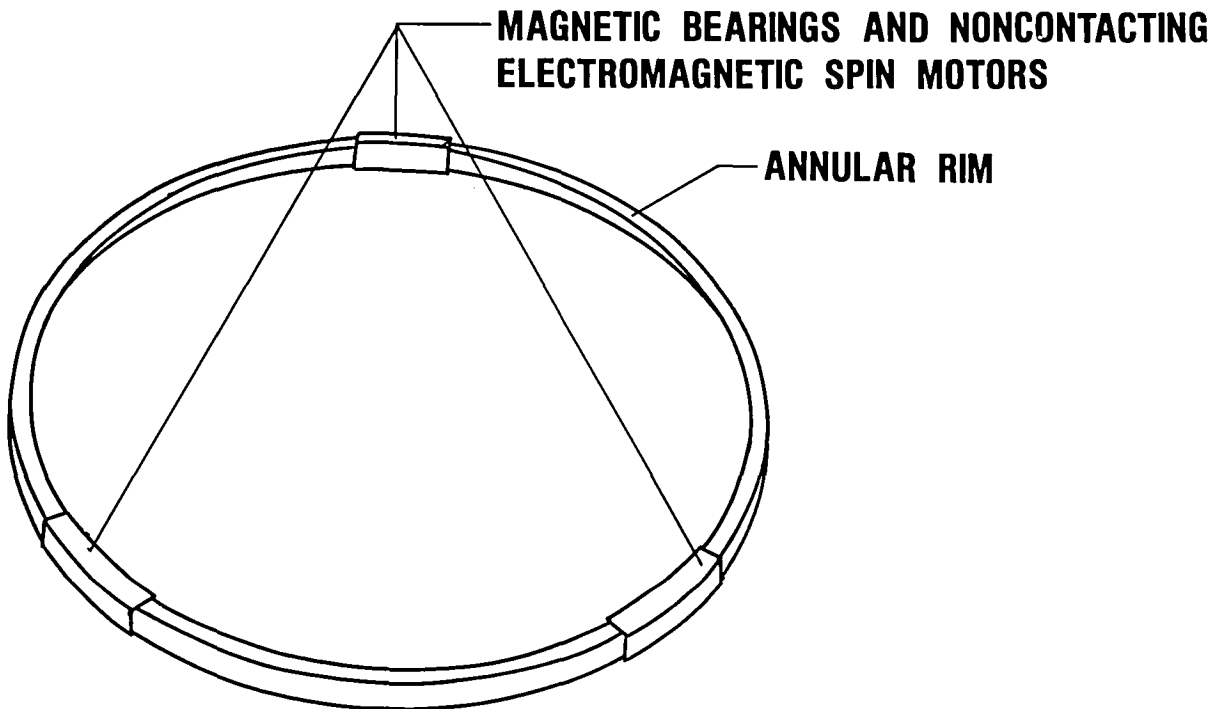

Figure 1

## AMCD APPLICATIONS

The AMCD concept was developed to meet projected spacecraft attitude control systems requirements. For attitude control applications, the AMCD can be used as the spin assembly for conventional momentum storage devices such as CMG's, reaction wheels, and momentum wheels. However, because of its unique geometry, the AMCD makes possible new, large radius, large momentum applications. Because they are new, these large radius applications have been emphasized in the majority of AMCD applications studies. Another potential application of the AMCD is energy storage since the rim shape allows full utilization of the filament strengths of composite materials by allowing a unidirectional layup. A third application, which is the subject of this workshop, would be in an integrated attitude control and energy storage system. Figure 2 presents a summary of applications.

### □ ATTITUDE CONTROL

- Spin Assembly for conventional momentum storage devices such as CMG's, reaction wheels, etc.
- New, large radius, large momentum applications made possible by unique geometry

### □ ENERGY STORAGE

- Rim shape allows full utilization of the filament strengths of composite materials by allowing a unidirectional layup.

### □ COMBINED ATTITUDE CONTROL/ENERGY STORAGE

- Tradeoff between optimum H/M and energy density rim design.

Figure 2

## AMCD ADVANTAGES (Momentum Storage)

The AMCD has advantages over conventional momentum storage devices because of its unique configuration (i.e. magnetically suspended thin rim). Figure 3 presents a list of advantages on both a device and system level. This configuration is also potentially much simpler mechanically (more complicated electronically) which should translate into lower cost.

### □ POTENTIAL DEVICE RELATED ADVANTAGES

- BEST SHAPE FOR MOMENTUM STORAGE (MAX H/m)
- ALLOWS USE OF ADVANCED COMPOSITE MATERIALS IN UNIDIRECTIONAL LAYUP
- ALLOWS MAXIMUM RADIUS ( $H/m \propto R_0$ )
- ISOLATED ROTATING RIM
- MINIMIZED WEAR (NO CONTACT)
- HIGHER RELIABILITY (THAT OF SOLID STATE ELECTRONICS)
- DIRECT CONTROL OF TORQUE
- NO BREAKOUT TORQUE

### □ POTENTIAL SYSTEM RELATED ADVANTAGES

- HIGH SPACECRAFT DAMPING IN MOMENTUM WHEEL APPLICATION
- SMOOTH, LOW-LEVEL MAGNETIC TORQUES FOR FINE POINTING
- COMBINED SPACECRAFT MANEUVER AND FINE POINTING CAPABILITY FOR GIMBALED APPLICATION
- ANNULAR GEOMETRY ALLOWS MAXIMUM PAYLOAD VOLUME UTILIZATION

### □ LOWER COST (SIMPLICITY)

## PARAMETERS OF LABORATORY MODEL AMCD

In order to investigate any potential problem areas in implementing the AMCD concept for large radial dimensions, a contract for the design and fabrication of a laboratory model was awarded to Ball Research Corporation. The model was delivered in early 1975. It should be emphasized that the lab model was not sized for a particular mission but was sized to fit an existing torque measuring fixture. The parameters of the model are given in Figure 4.

- MOMENTUM
  - 3000 ft-lb-sec
- RIM DIAMETER
  - 5.5 ft.
- RIM WEIGHT
  - 50 lb.
- RIM SPEED
  - 3000 RPM

Figure 4

## DESCRIPTION OF LABORATORY MODEL AMCD

The AMCD laboratory model, shown in Figure 5, consists of a graphite-epoxy composite rim that is suspended by three equally spaced suspension stations. Magnetic-bearing elements located in the suspension stations interact with a low-loss ferrite material, embedded in the rim, to produce radial and axial suspension forces. Electromagnetic stator elements, also located at the suspension stations, push and pull against 72 equally spaced samarium cobalt permanent magnets, embedded in the rim near the outer edge, to produce spin torques. The stator-element drive electronics are commutated by signals from a Hall effect device which senses the position of the magnets. Six backup bearings (two per suspension station) are included to prevent damage to the rim during spin tests. The backup and suspension bearing assemblies are attached to an aluminum baseplate. A vacuum cover (not shown) fits over the bearing-motor-rim assembly and also attaches to the baseplate. The cover is used for high-speed spin tests only. A detailed description of the AMCD laboratory model, as it was delivered, is presented in Reference 2.

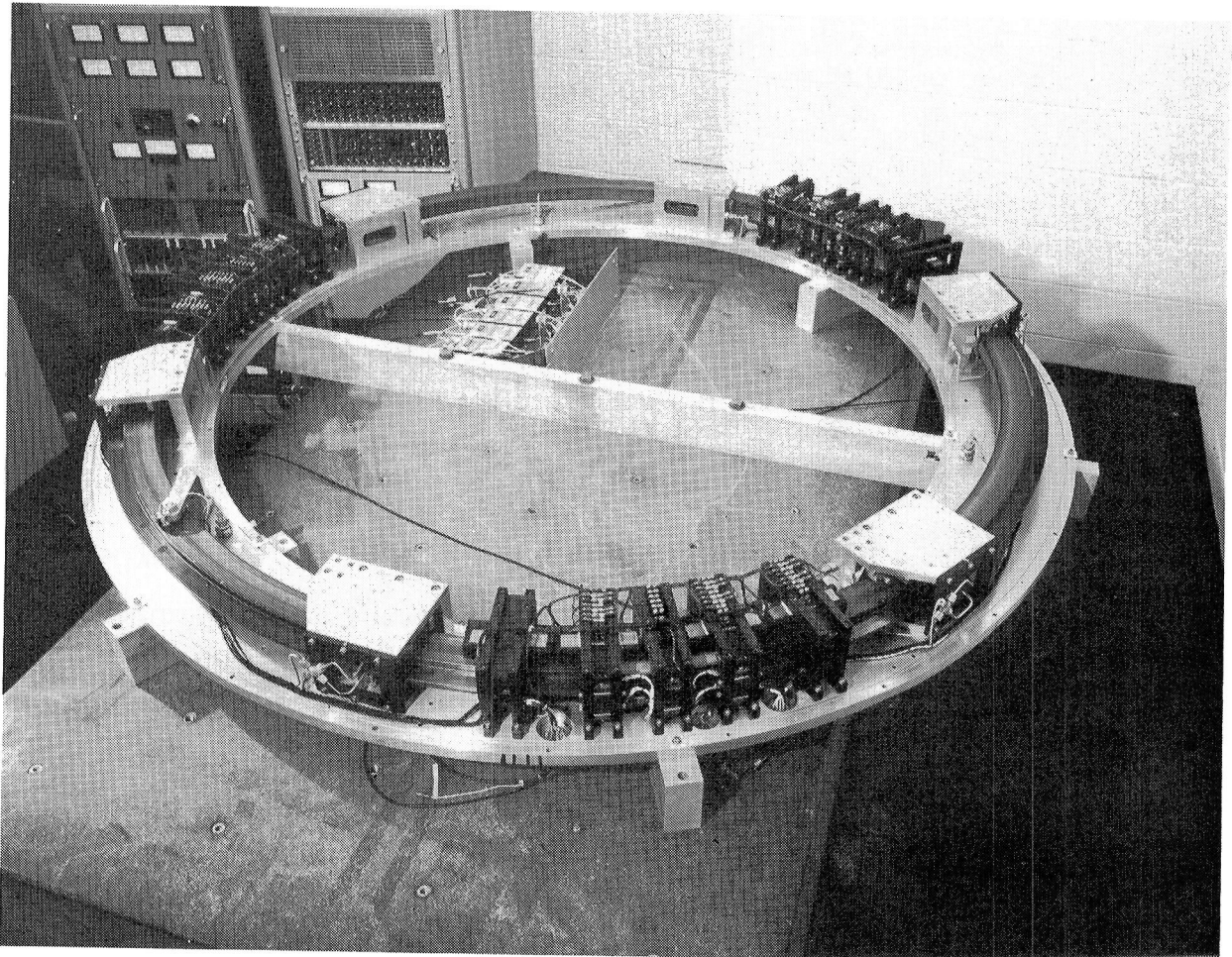

Figure 5

## SUMMARY OF RESULTS FROM AMCD LABORATORY MODEL TEST PHASE

A summary of results from the AMCD laboratory model test phase is presented in Figure 6. More details are available in References 3,4, and 5.

- RIM DESIGN
  - Unidirectional layup of composite material demonstrated as viable approach for rim fabrication.
  - If adversely loaded during periods of storage, unidirectional layup rim subject to creep.
  - Practical solution to the problem of integrating efficient magnetic materials (bearing and motor requirement) with basic high strength composite rim structure demonstrated. Advances in composite and magnetic material technology should make more efficient solutions possible.
- MAGNETIC BEARINGS
  - Segmented bearings with a minimum of three segments or "stations" demonstrated as viable approach.
  - Permanent magnet flux-biasing presented problems from control system standpoint. Bandwidth required to stabilize bearings too high.
  - Zero bias-flux magnetic bearings allowed lower control system bandwidth. However, other approaches being investigated.
- RIM DRIVE MOTOR
  - Segmented stator motor with permanent magnets embedded in rim to form motor poles demonstrated as viable approach.
  - Data from low speed tests indicated higher drag than predicted. Loss attributed to flux from open magnets in rim cutting base plate, cover, and motor stator and bearing-element cores.
  - Advances in composite and magnetic material technology should make more efficient solutions possible.
- MAGNETIC SUSPENSION CONTROL SYSTEM
  - Basic problem statement: 5-degree-of-freedom control with coupling through momentum vector which changes magnitude as rim is spun up.
  - Initial approach using classical single-input single-output control theory found to be inadequate.
  - Recent developments in multi-input multi-output control approaches, resulting from research efforts on large space structures control, should be applicable.
  - Digital controller will be required because of magnitude (i.e. number of feedback variables and gains) and nature (i.e. possibility of scheduled or variable gains) of control problem.

Figure 6

EFFORTS REQUIRED TO COMPLETE AMCD  
LABORATORY MODEL TEST PHASE

The AMCD laboratory model test phase has not been completed. However, valuable information on rim design and magnetic suspension approaches has been obtained. For example, results from the laboratory tests provided significant inputs to the Annular Suspension and Pointing System (ASPS) development effort (Reference 6). Presented in Figure 7 are the efforts required to complete the AMCD laboratory model test phase with the existing hardware.

- IMPLEMENT ALL DIGITAL CONTROLLER
- COMPLETE DEVELOPMENT OF MAGNETIC BEARING ACTUATOR CONTROL APPROACH
- DEVELOP ADVANCED SUSPENSION CONTROL LAWS
- COMPLETE HIGH SPEED SPIN TESTS

Figure 7



## REFERENCES

- (1) Anderson, Willard W.; and Groom, Nelson J.: The Annular Momentum Control Device (AMCD) and Potential Applications. NASA TN D-7866, March 1975.
- (2) Ball Brothers Research Corporation: Annular Momentum Control Device (AMCD). Volumes I and II. NASA CR-144917, 1976.
- (3) Groom, Nelson J.; and Terray, David E.: Evaluation of a Laboratory Test Model Annular Momentum Control Device. NASA TP-1142, March 1978.
- (4) Groom, Nelson J.; and Waldeck, Gary C.: Magnetic Suspension System for a Laboratory Model Annular Momentum Control Device. A Collection of Technical Papers--AIAA Guidance and Control Conference, August 6-8, 1979, PP. 423-428. (Available as AIAA Paper 79-1755).
- (5) Groom, Nelson J.; Woolley, Charles T.; and Joshi, Suresh M.: Analysis and Simulation of a Magnetic Bearing Suspension System for a Laboratory Test Model Annular Momentum Control Device (AMCD). NASA TP-1799, March 1981.
- (6) Anderson, Willard W.; Groom, Nelson J.; and Woolley, Charles T.: The Annular Suspension and Pointing System. Journal of Guidance and Control, Vol. 2, No. 5, September-October 1979, PP. 367-373.

MAGNETIC BEARINGS FOR INERTIAL ENERGY STORAGE

Philip A. Studer  
NASA Goddard Space Flight Center  
Greenbelt, Maryland

## KEY FEATURES

The original decision which targeted magnetic suspension for technology development was aimed at finding a noncontacting bearing technique with no wear-out phenomena and which was vacuum compatible. This remains the decisive factor in selecting magnetic bearings for kinetic energy storage. Unlimited cycle life without degradation is a primary goal. Good "storage efficiency" demands a fully evacuated enclosure.

"Storage efficiency" is a key parameter which we define as the ratio of the energy remaining to energy stored after a fixed time interval at no load conditions. Magnetic bearings, although noncontacting, are not perfectly frictionless in that magnetic losses due to eddy currents and hysteresis can occur. These can theoretically, with perfect symmetry, be zero--the late Dr. Beams, University of Virginia, demonstrated rotational rate losses of one part per million per hour on magnetically suspended spheres. Practical magnetic bearings however, deviate from perfect symmetry and have discontinuities and asymmetric flux paths either by design or when controlled in the presence of disturbances, which cause losses. These losses can be kept smaller in the bearings than in a high power motor/generator, but nonetheless are a significant factor in selecting the magnetic bearing type.

- o LIFE UNLIMITED BY WEAROUT PHENOMENA OR ROTATIONAL RATE
- o OPERATION UNAFFECTED BY ENVIRONMENT, NO LUBRICATION REQUIREMENT
- o LOW ROTATIONAL LOSSES (NOT FRICTIONLESS) CONTRIBUTE TO STORAGE EFFICIENCY

**LONG LIFE**

**VACUUM COMPATIBILITY**

**HIGH "STORAGE" EFFICIENCY**

## TYPE OF MAGNETIC BEARINGS

Numerous magnetic bearing types have been built and tested successfully. All known successful high load designs operate in the attractive mode. At least one actively controlled axis is needed and the number and direction of the controlled axes characterized each design, e.g., Axial (1), Radial (4), Radial and Transverse (4); many other combinations are possible and have been successfully implemented.

At the GSFC the earliest designs are axial, which most readily approaches perfect symmetry and has the virtue to simplicity and minimum control electronics. Load capacity and stiffness in the passive (not actively controlled) axes are difficult to obtain, typically 1/4 to 1/10 of the active direction, and are, of course, fixed by design. Attempts to increase damping in the passive direction have not met with great success and tend to increase rotational losses.

Another categorization of bearing types is pure electromagnet versus P.M. (permanent magnet) biased. Again our earliest work was done on straight electromagnets. They are mechanically simple but introduce a nonlinear force/current relationship. They use considerable power and have no cross axis (passive) stiffness when unpowered. P.M. biased electromagnetic bearings were invented to reduce power and provide power-off cross axis stiffness. This also linearizes the force/current relationship (constant gap) and it has further been found that the reduced ampere-turn requirement can provide a good (and much needed) power versus response-time tradeoff.

Other types of magnetic bearings include superconducting (not feasible here), repulsion, and air core control; neither of which have been successful for greater than instrument size loads in 1 g, to my knowledge. We have always assumed a system must be fully testable in 1 "g" which turns out to be not overly constraining when dynamic loads are considered.

**AXIAL**  
ONE DEGREE OF FREEDOM  
CONTROL (2 BEARINGS)

**RADIAL**  
TWO DEGREE OF FREEDOM  
CONTROL (2 BEARINGS)

**MULTIPLE**  
FOUR/FIVE DEGREE OF FREEDOM  
CONTROL (SINGLE BEARING)

**ELECTROMAGNET**  
HIGH POWER DISSIPATION  
UNDER "G" LOAD  
  
NO PASSIVE STIFFNESS

**PERMANENT MAGNET BIASED**  
REDUCED AMPERE TURNS  
  
FASTER RESPONSE - LOW POWER  
  
LINEAR FORCE/AMP

**AIR-CORE**  
LOW FORCE

**SUPERCONDUCTING**  
NOT CURRENTLY FEASIBLE

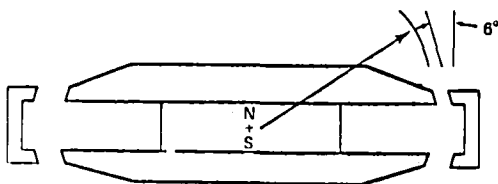

## CHARACTERISTICS

Some of the key characteristics have already been mentioned in discussing various types. A general limitation is that all magnetic bearing designs are of limited peak load capacity set by the saturation value of magnetic materials, fixing an approximate upper limit of 230 psi reduced by control range selection. The stiffness is variable at the designer's discretion, but even negative values are permissible in certain frequency ranges. The response time is a major consideration as with all inductive loads. Current (force) drive has been used effectively to move the electrical time constant outside the control bandwidth.

Perhaps the easiest mistake is to relegate torsional modes to a secondary consideration. The gyroscopic forces of a kinetic energy storage wheel make these the most important. Single bearing wheel suspension has been utilized on many GSFC spacecraft momentum wheels with conventional (ball) bearings. A single magnetic bearing reaction wheel was developed at the GSFC and is well documented in a NASA document (ref. 1) and a U.S. patent (ref. 2). This design allows angular excursions about the center of mass without reluctance change. With appropriate (tilt) sensors the angular characteristics can be readily controlled. A recent Japanese design employs this concept. The single bearing concept has considerable merit for kinetic energy (K.E.) wheels since it permits a monolithic wheel with only rigid body modes in the control bandwidth and avoids the complexity and minimizes the weight and size of the stator elements.

LIMITED LOAD CAPACITY	(250 PSI)
NEGATIVE STABILITY *	(P.M.) CROSS AXIS (MOST)
RESPONSE TIME	INDUCTIVE AND HYSTERETIC
ROTATIONAL LOSSES	FLUX REVERSALS, NON-SYMMETRY, AND DISCONTINUITIES
ANGULAR FREEDOM	GYROSCOPIC LOADS

\* PARTICULARLY PERMANENT MAGNET BIASED

## APPLICATION TO K.E. STORAGE

The application of magnetic bearings to kinetic energy storage wheels seems convincing from the standpoint of lifetime, storage efficiency, and multiaxis control requirements. Earlier doubts about electronics complexity and reliability are no longer issues, given the option of redundancy and multiaxis digital control processors. Many sensor options are available with capacitive sensors having the advantages (analogous to magnetics) of greater sensitivity at small gaps and relatively large areas; they can therefore be built into the working airgap (avoiding any mechanical resonances for phase shift) and take no additional space or weight. The cost of magnetic bearing hardware is not unreasonably larger than equivalent precision ball bearings however this is almost negligible in comparison to the engineering costs at this stage of development.

### HIGH SPEED OPERATION INHERENT

#### ROTATIONAL LOSSES MUST BE MINIMIZED

- NO FLUX REVERSALS
- NO DISCONTINUITIES
- FULLY EVACUATED CHAMBER

### ATTITUDE CONTROL INTERACTION INHERENT

#### CONTROL OF SPIN VECTOR REQUIRED

- ANGULAR ALIGNMENT
- ROTATIONAL RATE
- UNBALANCE DISTURBANCE

### ROTOR DYNAMICS MUST BE MINIMIZED

#### MONOLITHIC (WHEEL, MOTOR, BEARING) RECOMMENDED

- RIGID BODY MODES ONLY
- MINIMUM STATOR WEIGHT
- CONTROLLED ANGULAR FREEDOM

## ISSUES

The overriding issues of magnetic bearings in K.E. wheels centers on safety. A fail safe or soft failure mode must be assured. The motor/generator can provide bearing power during power outages. A backup bearing has usually been included for emergency coast down. An externally pressurized gas bearing was selected and designed into the 5.5-foot-diameter 3000-ft-lb-sec AMCD jointly developed by Langley Research Center and Goddard Space Flight Center at Ball Aerospace. This has the additional advantage of slowing the rotor by windage drag and providing an additional thermal path to limit the temperature rise due to sudden braking. Conventional (ball) backup bearings must be dry lubricated.

Secondary issues relative to the bearing are the paucity of analytical design tools to confidently predict high speed rotational losses in the motor and bearing magnetics due to the nonlinearities and geometric complexity. Another issue not fully defined is peak load limits of the application requirements in terms of both composite rotor residual and degraded balance and external base motion disturbances such as docking impact, induced rates, etc.

This overview of magnetic bearings for K.E. storage applications is supplemented by a substantial list of NASA, journal, and patent literature; a partial bibliography is appended to this text. Virtually all of the work described and referenced has been supported by the OAST since 1969. The successful test program to date of a Stirling Cycle Cryogenic Cooler with linear magnetic bearings adds to the growing belief that magnetic bearings are approaching flight readiness and that machines with no wear-out are becoming a reality.

## SAFETY

- o FAIL SAFE/SOFT MODE MUST BE ASSURED

BACK-UP BEARINGS, DRY LUBE BALL AND/OR GAS  
GENERATOR SUPPLIED SUSPENSION POWER

## ANALYTICAL AND SIMULATION TOOLS

- o NON-LINEAR MAGNETICS/DYNAMICS

## PEAK LOAD LIMITS/OPERATIONAL CONSTRAINTS

- o GYROSCOPIC BEHAVIOR, BASE MOTION RATES AND DISTURBANCES
- o BALANCE DEGRADATION, CYCLIC AND THERMAL STRESS

## REFERENCES

1. Studer, P. A.: Magnetic Bearings for Instruments in the Space Environment. NASA TM-78048, Jan. 1978.
2. Studer, P. A.: Magnetic Bearing System. U.S. Patent 4,000,929, Jan. 1977.

## BIBLIOGRAPHY

Kirk, James A.; Studer, P. A.; and Evans, H. E.: Mechanical Capacitor. NASA TN D-8185, 1976.

Rodriguez, G. E.; Studer, P. A.; and Baer, D. A.: Assessment of Flywheel Energy Storage for Spacecraft Power Systems. NASA TM-85061, 1983.

Studer, P. A.: Magnetic Bearings for Instruments in the Space Environment. NASA TM-78048, 1978.

Studer, P. A.: Magnetic Bearings for Spacecraft. NASA TM X-66111, Jan. 1972.

Studer, P. A.; and Evans, H. E.: In-Space Inertial Energy Storage Design. Proceedings 16th Intersociety Energy Conversion Engineering Conference, vol. 1, ASME, 1981, pp. 74-79.



**Page intentionally left blank**

ADVANCED CONTROL AND POWER SYSTEM (ACAPS)  
TECHNOLOGY PROGRAM

C. R. Keckler and N. J. Groom  
NASA Langley Research Center  
Hampton, Virginia

## PROGRAM OBJECTIVE

The primary objective (fig. 1) of the Advanced Control and Power System (ACAPS) program is to establish the technology necessary to satisfy Space Station and related large space structures requirements for efficient, reliable, and cost effective energy storage and attitude control. Technology advances in the area of integrated flywheel systems capable of performing the dual functions of energy storage and attitude control will be pursued.

ESTABLISH THE TECHNOLOGY TO SATISFY SPACE STATION AND RELATED  
LARGE SPACE STRUCTURES REQUIREMENTS FOR EFFICIENT AND RELIABLE  
ENERGY STORAGE/ATTITUDE CONTROL.

Figure 1

## PROGRAM JUSTIFICATION

Space station and related large space structures are, generally, assemblies of loosely coupled modules with low frequency flexible modes which, because of their mission objectives, must be provided with robust and, most importantly, reliable control. To achieve these requirements, advances in large control actuators must be realized. Large energy storage and power demands are also in the nature of these advanced missions because of the numerous research and operational tasks being proposed. These demands must be satisfied by highly efficient systems (to minimize weight and volume as well as solar array sizes) which are capable of long-term and uninterrupted operation in order to reduce logistical support and thus maximize cost effectiveness. Integrated flywheel systems, which combine the functions of attitude control and power subsystems into one system, have the potential of providing these benefits. Figure 2 presents a summary of the ACAPS program justification.

- TECHNOLOGY ADVANCES IN LARGE CONTROL ACTUATORS MUST BE REALIZED TO PERMIT ROBUST, RELIABLE CONTROL OF SPACE STATION AND RELATED LARGE SPACE STRUCTURES.
- ENERGY STORAGE AND POWER LEVEL REQUIREMENTS FOR THESE MISSIONS INDICATE THE NEED FOR TECHNOLOGY ENHANCEMENTS IN THE AREAS OF EFFICIENT STORAGE SYSTEMS CAPABLE OF LONG-TERM, UNINTERRUPTED COST-EFFECTIVE OPERATION.
- POTENTIALLY SIGNIFICANT BENEFITS HAVE BEEN IDENTIFIED IN FLYWHEEL ENERGY STORAGE AS WELL AS IN COMBINED ENERGY STORAGE/ATTITUDE CONTROL SYSTEMS.

Figure 2

## BACKGROUND

Research into the viability of integrated power/attitude control systems was conducted by the NASA Langley Research Center in the 1970's. The results of these efforts (fig. 3) indicated that such systems are technically feasible and offer substantial benefits over the conventional approaches of separate systems for different functions (refs. 1 and 2). Even when assuming equivalent energy densities between electro-chemical techniques and flywheel subassemblies, the integrated kinetic storage systems proved superior since the weight and volume of the required spacecraft control actuators had been saved by such an approach. Energy storage and withdrawals in kinetic storage systems are effected by altering the speed of the rotating flywheel. Such speed changes are reflected as a disturbance on the spacecraft because of the resultant momentum variations ( $\dot{H}$ ). However, as was demonstrated in reference 3, these variations are readily accommodated by the integrated systems by changing the gimbal positions of each actuator. Achieving the full benefits offered by this integrated system approach in a space station application will necessitate technology advances in composite material rotors and magnetic bearing suspensions.

### RESULTS OF IPACS STUDIES PERFORMED IN EARLY 1970's:

- FLYWHEEL ENERGY STORAGE FOR SPACECRAFT APPLICATIONS TECHNICALLY FEASIBLE
- FLYWHEEL CONCEPTS OFFER SUBSTANTIAL BENEFITS OVER CONVENTIONAL SYSTEMS OF COMPARABLE TECHNOLOGY STATES
- BENEFITS OF FLYWHEEL CONCEPTS OVER CONVENTIONAL APPROACHES INCREASED WITH NUMBER OF CHARGE-DISCHARGE CYCLES AND MISSION LIFE
- ASSUMING EQUIVALENT ENERGY DENSITIES, COMBINED ENERGY STORAGE AND ATTITUDE CONTROL PROVED TO BE SUPERIOR TO CONVENTIONAL APPROACHES OF SEPARATE SYSTEMS
- VARIATIONS IN ENERGY STORAGE LEVELS OF FLYWHEELS READILY ACCOMMODATED BY CONTROL SYSTEM SOFTWARE
- TECHNOLOGY ADVANCES NEEDED IN COMPOSITE MATERIAL ROTORS AND MAGNETIC SUSPENSIONS TO SATISFY ENERGY/POWER AND CONTROL REQUIREMENTS OF SPACE STATIONS

Figure 3

## TRADE STUDY MISSIONS

The applicability of an integrated power/attitude control system to a variety of mission types was examined in reference 1. These missions encompassed small earth orbiting satellites, planetary spacecraft, and large modular space stations. As can be seen in figure 4, the requirements for control on these missions ranged from 1 arcsecond to one degree, while power demands extended from 300 watts to 19 kilowatts. The results of this study indicated that significant weight, volume, and costs savings could be realized when employing an integrated system over a conventional system design for all mission types studied with the exception of the planetary spacecraft. The low power and control demands placed on the integrated system by the planetary mission during transit and encounter made conventional systems more cost effective.

	POINTING ACCURACY ±DEGREES	POWER LEVEL WATTS	REMARKS
NEAR EARTH SATELLITE: EARTH OBSERVATIONS SATELLITE	1.0	727W	EARTH OBSERVATORY SOLAR ARRAY/BATT.
GEOSYNCHRONOUS SATELLITE: TRACKING & DATA RELAY SATELLITE	0.9	300W	COMMUNICATIONS SATELLITE SOLAR ARRAY/BATT.
PLANETARY SATELLITE: MARINER-JUPITER/SATURN	0.05	350W	SCIENTIFIC SATELLITE RTG
SHUTTLE 30 DAY MISSION: EARTH OBSERVATION & CONTAMI- NATION TECHNOLOGY	0.5	3000W	EARTH RESOURCES FUEL CELL
RAM: ADVANCED SOLAR OBSERVATORY	1SEC	3400W	ASTRONOMY SOLAR ARRAY/BATT.
MODULAR SPACE STATION	0.25	19000W	GENERAL PURPOSE SOLAR ARRAY/REGEN F/C

Figure 4

## TECHNOLOGY STATUS

Spinning flywheels have been widely used by various government agencies and industry for several years. Applications of rotating devices have included control, energy storage, and combined control and energy storage applications (fig. 5). Control systems have employed rotating wheels as reaction wheels, momentum wheels, and in single- and double-gimbal control moment gyros. Energy storage utilizations of flywheels are encountered in automotive and mass transit applications, for providing on-demand high-power pulses, or for use in hazardous environments such as coal mines where high concentrations of explosive methane gas can be encountered. The combining of control and energy storage features of flywheels into one system has been examined by NASA for space applications and has been demonstrated in the laboratory.

### SPINNING WHEELS USED FOR:

- CONTROL SYSTEM APPLICATIONS

- NASA
- DOD
- INDUSTRY

- ENERGY STORAGE

- DOT
- DOE
- INDUSTRY
- DOD

- COMBINED ENERGY STORAGE/CONTROL

- NASA

Figure 5

## ADVANCED CONTROL MOMENT GYRO

A typical application of a rotating flywheel for spacecraft control is embodied in the advanced control moment gyro (CMG) of figure 6. This device utilizes a rotor spinning at approximately 6400 rpm to provide a momentum storage capacity of 4500 ft-lb-sec and, through the use of direct drive gimbal torquers, a control torque capability of up to 200 ft-lbs. This unit was developed for a space station application.

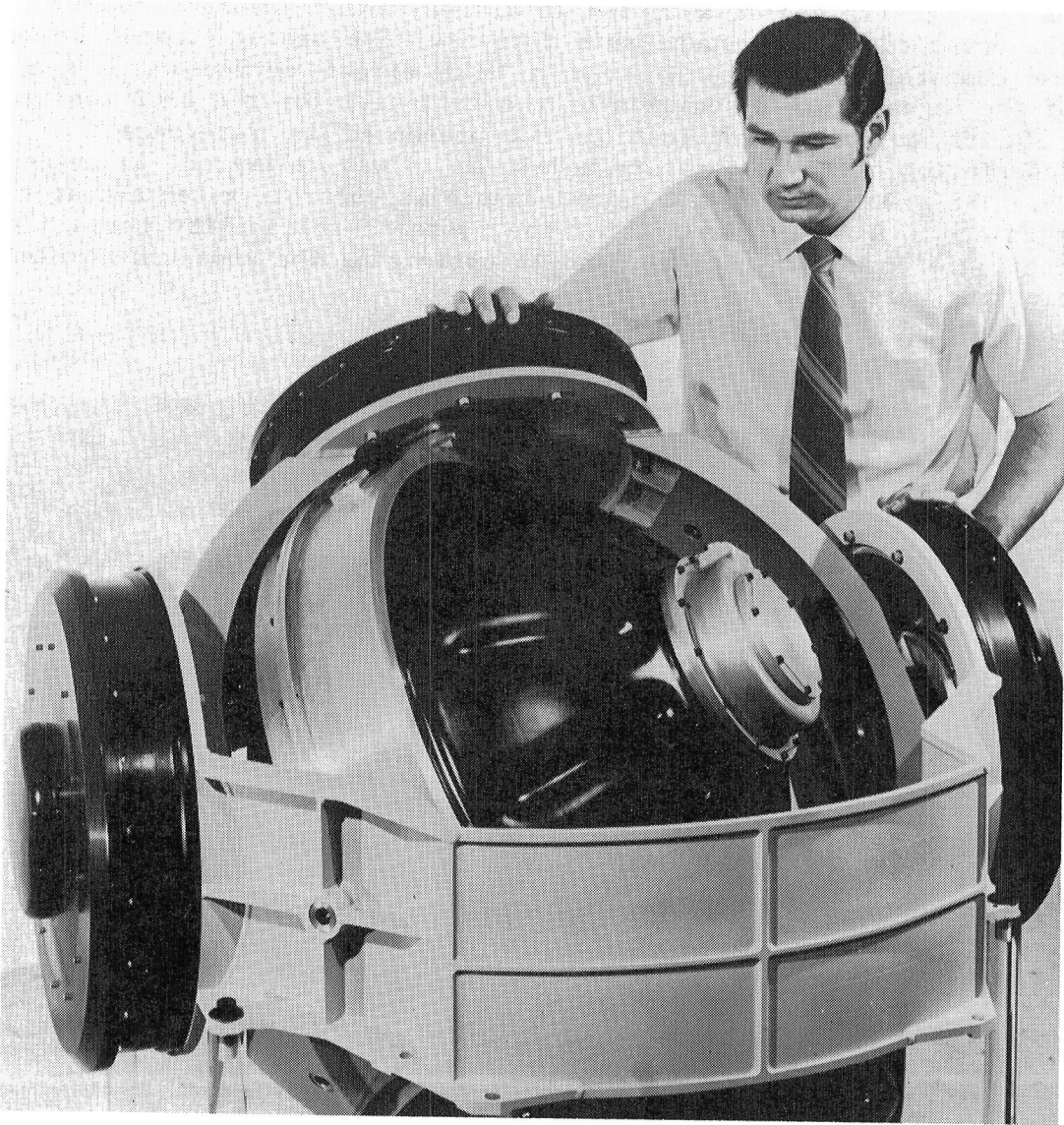

Figure 6



## ANNULAR MOMENTUM CONTROL DEVICE (AMCD)

A more advanced use of a rotating flywheel is in the Annular Momentum Control Device (AMCD) developed at the Langley Research Center. A laboratory model of this concept is depicted in figure 7. The laboratory model consists of a graphite-epoxy composite rim which is 5.5 ft in diameter, weighs 50 lbs, and is designed to rotate at a speed of 3000 rpm. At this speed the rim momentum is 3000 lb-ft-sec. The rim is suspended by three equally spaced suspension stations. Magnetic-bearing elements located in the suspension stations interact with a low-loss ferrite material, embedded in the rim, to produce radial and axial suspension forces. Electromagnetic stator elements, also located at the suspension stations, push and pull against 72 equally spaced samarium cobalt permanent magnets, embedded in the rim near the outer edge, to produce spin torques. The stator element drive electronics are commutated by signals from a Hall effect device which senses the position of the magnets. A discussion of the rationale for the AMCD configuration and some of its potential applications is presented in reference 4. A more detailed description of the laboratory model, as it was delivered, is presented in reference 5. The AMCD represents a major advance in control system actuator design due to its unique approach in maximizing the system's reliability through the use of noncontacting elements throughout, and in optimizing the momentum-to-mass ratio thus reducing the weight of the control system.

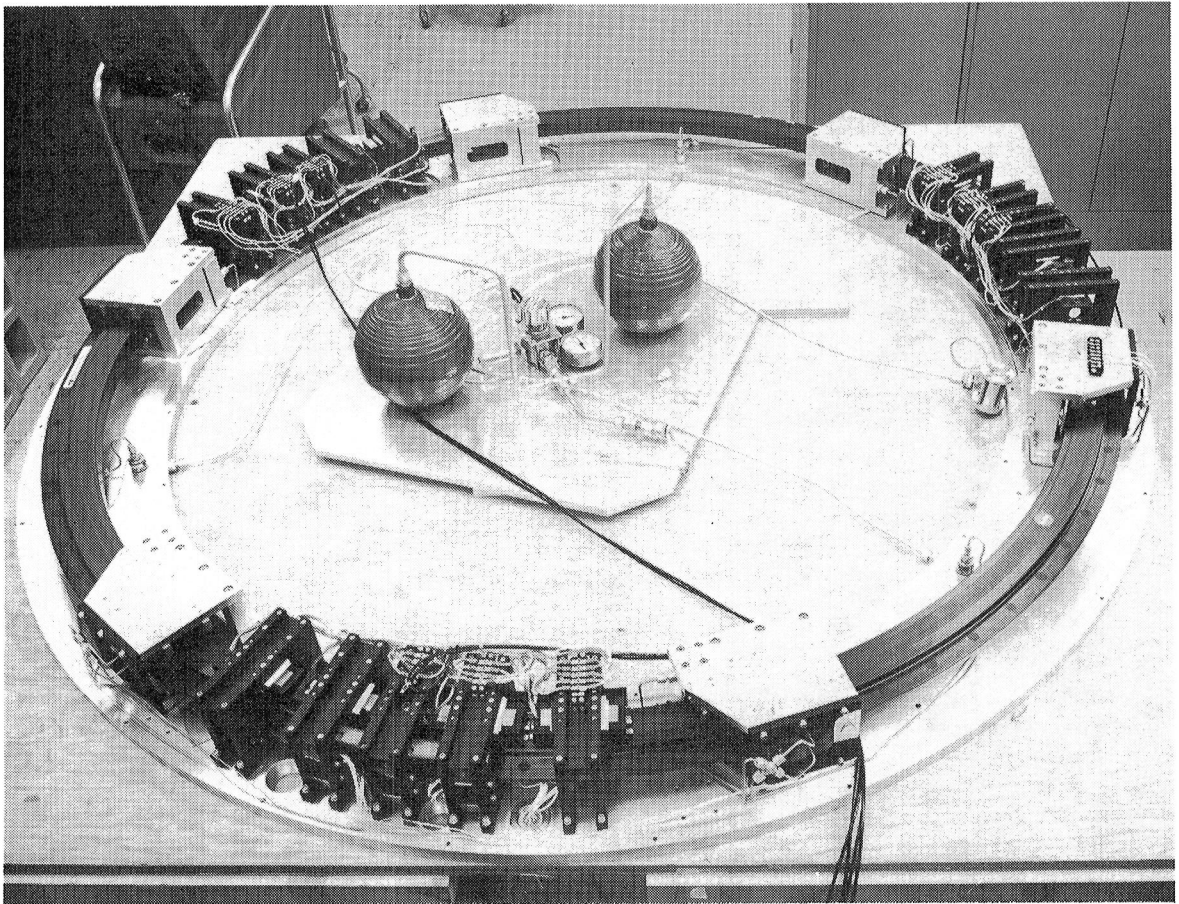

Figure 7

## DOE FLYWHEELS CONCEPTS

The Department of Energy (DOE) has recently examined the applicability of flywheels to satisfy the energy requirements of automobiles. To maximize the energy density of such storage devices and to reduce potential safety hazards, the research has concentrated on composite material rotors. A collection of the various designs resulting from this effort is shown in figure 8. A significant result of this research is that out of the ten wheel concepts developed and shown here, only two (in the center of the bottom line of the figure) are not of a rim-type configuration. The preponderance of rim designs indicates the viability of rotating rims for energy storage applications. Such designs permit the maximum utilization of material strength when using composites, thereby optimizing the system energy density.

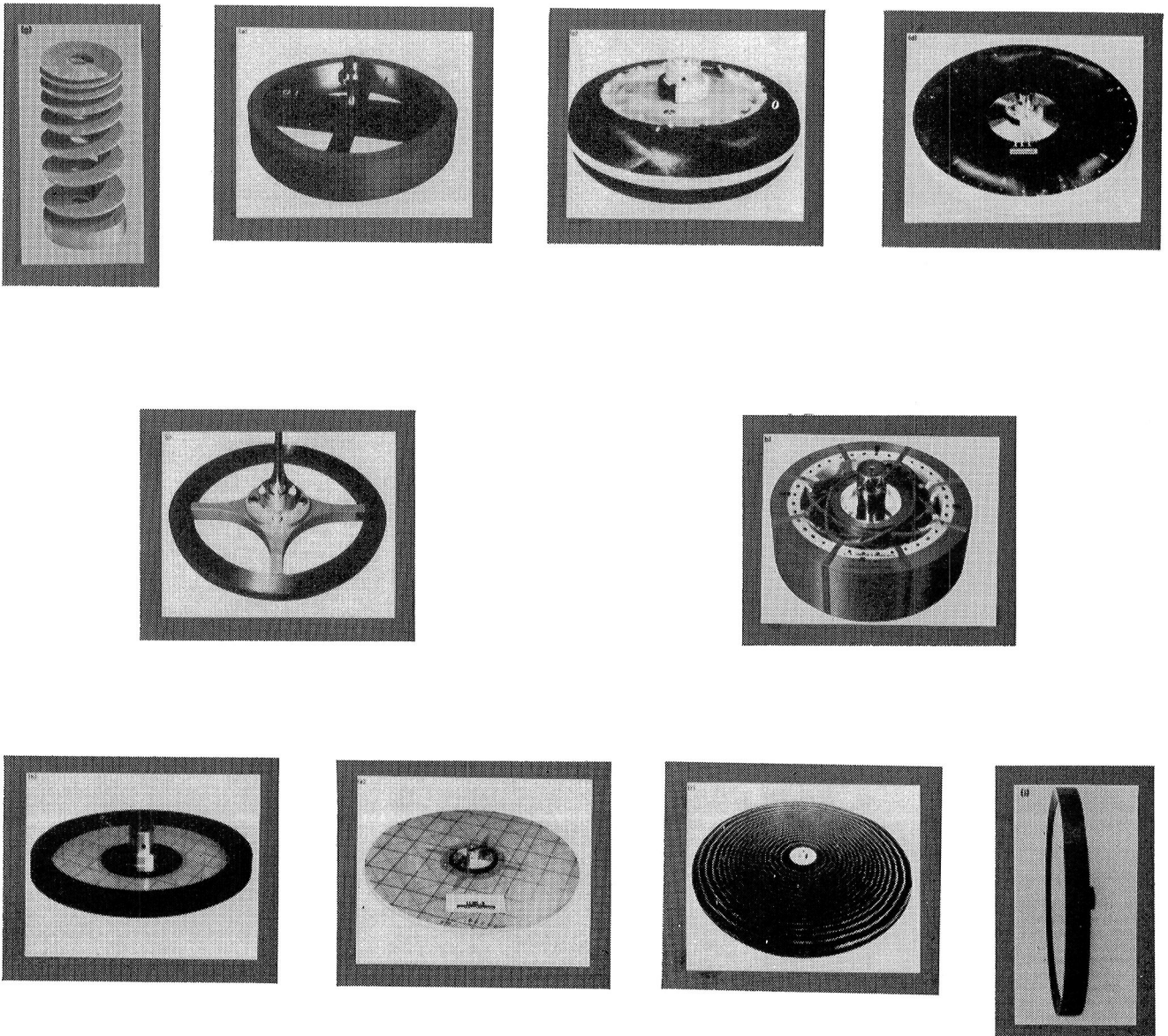

Figure 8

## FLYWHEEL POWER MODULE INSTALLATION

An industrial application of flywheels for energy storage is depicted in figure 9. A set of seven homogeneous material flywheels is used as the power module for a vehicle which must operate inside a coal mine. The environment in which this coal car must function frequently contains a high concentration of explosive methane gas which can be set off by the smallest spark, as might be triggered by battery devices, or heat source as resultant from internal combustion (IC) engines. IC engines also introduce pollutants into the air of the mine shafts, such as carbon monoxide, which are extremely lethal to personnel working in the area.

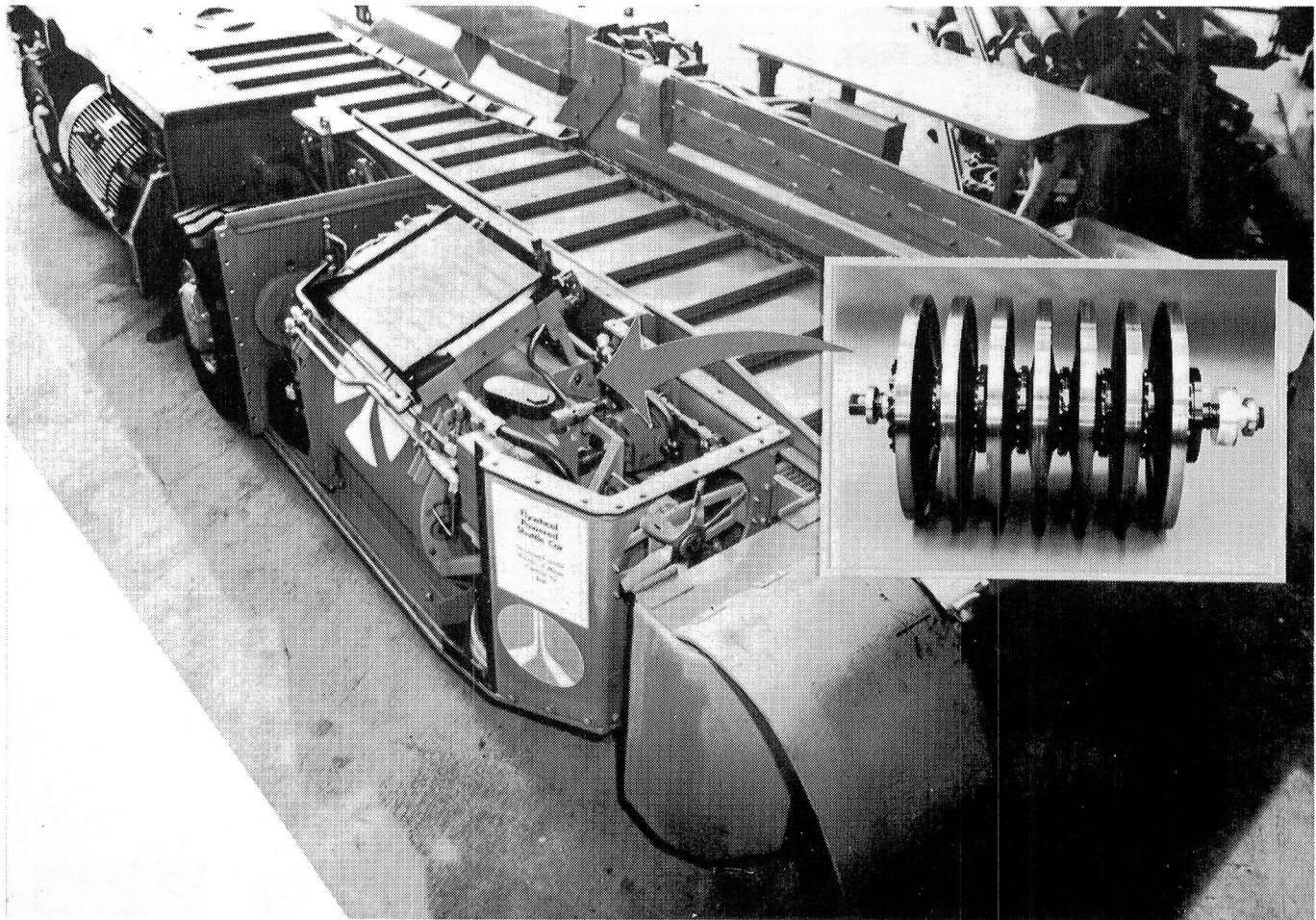

Figure 9



## IPACS ROTATING ASSEMBLY

Laboratory hardware for the rotating assembly of an integrated power/attitude control system (IPACS) is shown in figure 10. This device utilizes an 18-inch diameter titanium rotor, operating at a maximum speed of 35,000 rpm, to store 1.5 kilowatt-hours of energy. Through the use of brushless d.c. motor/generators, this assembly can provide 2.5 kilowatts of power. Since this unit is also the rotating assembly for a control actuator, the minimum operational rotor speed is maintained at 17,500 rpm or 50 percent of maximum which, however, still permits the extraction of 75 percent of the energy stored in the flywheel.

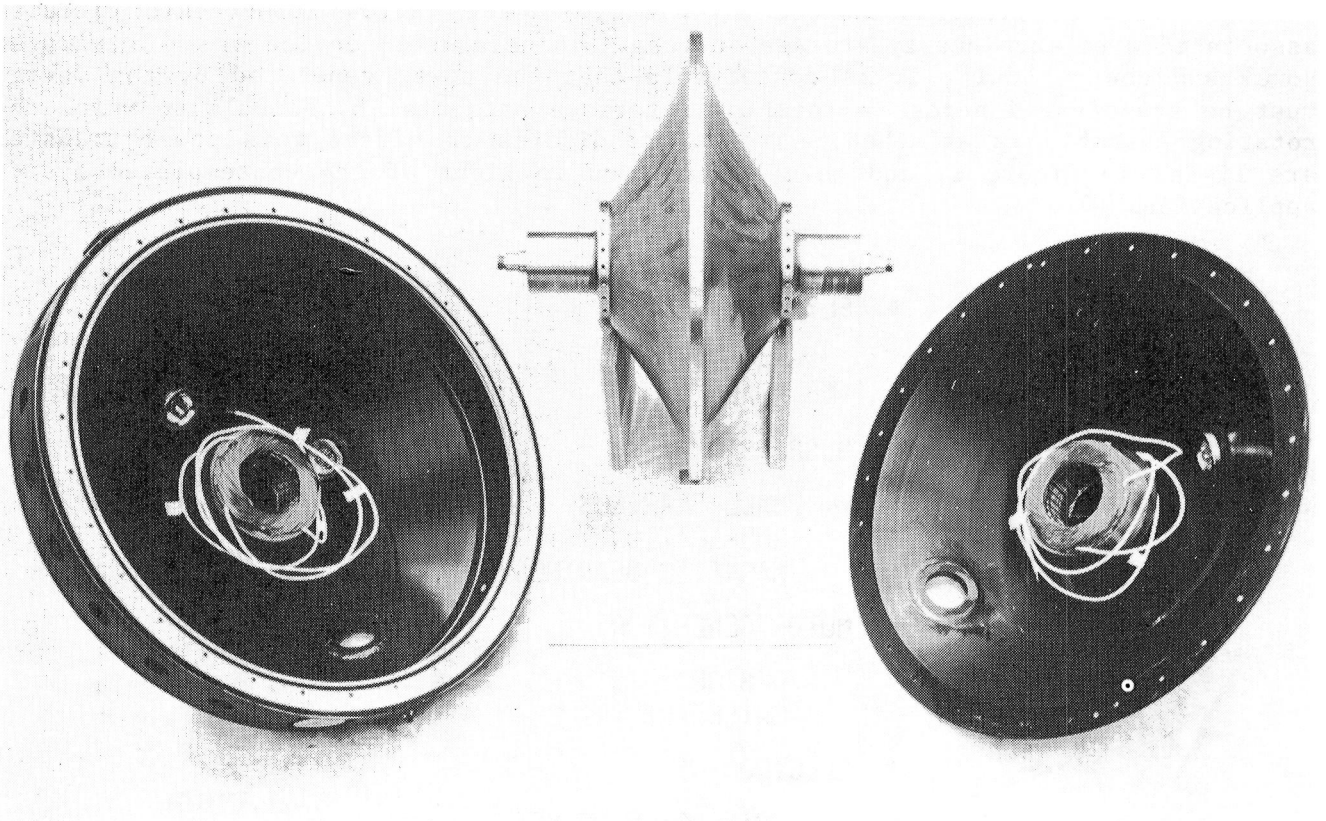

Figure 10

## TECHNOLOGY ISSUES

As can be recognized from the foregoing material, several technology issues remain to be addressed prior to applying the concept of an integrated power/attitude control system to a space station mission. These are summarized in figure 11. Among the major remaining questions are: What should be the shape of the flywheel, constant stress or annular? This is impacted by material selection which might be a homogeneous or a composite material. A significant impact of flywheel selection will be felt on the design of the rotor suspension system. Constant stress designs are amenable to using ball bearings as well as shaft-mounted magnetic bearings. However, annular flywheels will probably employ rim-mounted magnetic suspension exclusively to maximize the benefits of this configuration. The design of efficient motor/generators for use in high power application must be undertaken and, as has been shown in other efforts, significant advances must be realized in the efficiency of the various electronic circuits associated with such energy storage devices. In using this device as an integrated power and control unit, it is conceivable that the power generated by the device must be transferred across a rotating interface presented by gimbals to which the rotating assembly is attached. Typical candidates to effect this power transfer are listed in figure 11 and must be examined in light of the contemplated system application.

- FLYWHEEL
  - MATERIAL
  - SHAPE
- SUSPENSION
  - BALL BEARINGS
  - LUBRICATION
  - MAGNETIC BEARINGS
- MOTOR/GENERATOR
  - DESIGN
  - MATERIALS
- ELECTRONICS
  - SPIN MOTOR DRIVE
  - ENERGY EXTRACTION
  - POWER REGULATION
  - SUSPENSION
  - GIMBAL DRIVE
- POWER TRANSFER MECHANISMS
  - ROTARY TRANSFORMER
  - ROLLER RINGS
  - SLIP RINGS
  - CABLES

Figure 11

## SYSTEM TRADES

Two major elements in the design of an advanced spacecraft such as space station are the power and control systems. As seen in figure 12, power can be provided through the use of solar-array-battery assemblies (SAB), fuel cells (FC), or flywheels. Similarly, control can be effected through the employment of gravity gradient approaches, reaction control systems (RCS), or momentum storage devices which utilize rotating wheels. Since it has been shown that flywheels can be effectively used to satisfy the needs of the power and control subsystems, an integration of these functions into an advanced control and power system (ACAPS) is a logical evolutionary step in the enhancement of technology for future missions. In arriving at an optimum integrated system concept, several system-level trades must be conducted. Among these are, naturally, studies which will determine the impact of this integration on control law designs, energy management approaches, and failure detection and tolerance. System sizing studies must also be undertaken to determine the energy/power levels required of the integrated system and of each unit, as well as to establish the control authority needed from the system's actuators. Contingency levels associated with mission survivability in the areas of both control and power must be established and placed as requirements on the system definition and design. The thoroughness and timely completion of such studies will permit the realization of the full benefits possible with such an integrated system approach.

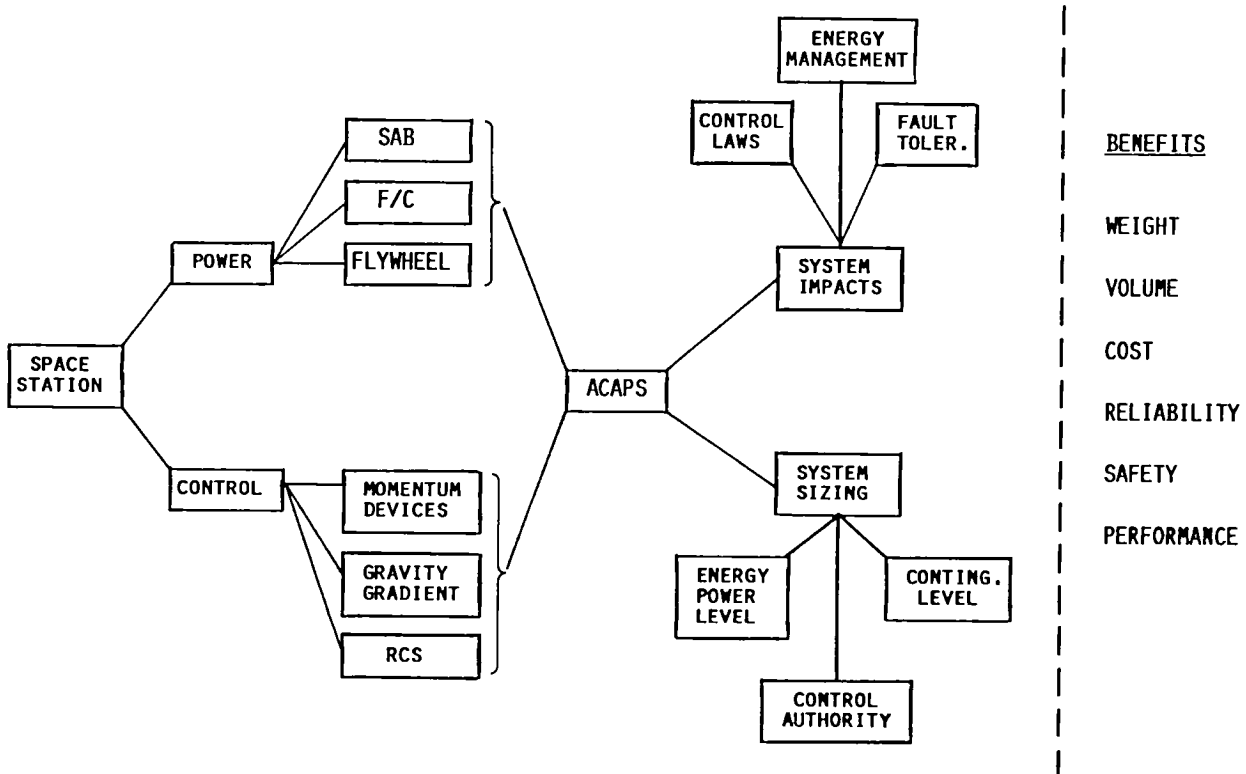

Figure 12

## PROGRAM MANAGEMENT

A program to advance the technology associated with an integrated power/attitude control system encompasses several disciplines, e.g. control design, materials, motor/generators, electronics, etc. Because of this large disciplinary scope, several program offices are involved which provide the resources required by each of these areas. In addition, the necessary technical expertise to achieve the desired technology enhancements resides at various field centers thus giving rise to multi-center interest. In order to maximize returns on allocated resources and to minimize duplications of effort, a lead center approach to program management is recommended. The lead center, as shown in figure 13, will act as the necessary interface between the various Headquarters program offices and the field center technology organizations. The Langley Research Center has been proposed for this lead center role because of its unique experience in the design and evaluation of control system hardware, its position as the only field center having flywheel energy storage system hardware, its expertise in the area of magnetic bearing suspension application to rotating systems as evidenced by the AMCD, and also because of its technology advancement programs in the areas of noncontacting power and data transfer mechanisms. A description of the proposed program management approach is shown in the block diagram of figure 13.

### ISSUES

- MULTI-DISCIPLINES INVOLVED
- MULTI-CENTER INTEREST
- MULTI-PROGRAM OFFICES CONCERNED
- LIMITED RESOURCES AVAILABLE

### APPROACH

- ESTABLISH LEAD CENTER CONCEPT
  - EFFECT CLOSE COORDINATION OF PROGRAM OFFICES
  - CAPITALIZE ON CENTER STRENGTH AND EXPERTISE
- INSTITUTE ADVISORY COMMITTEE FOR PROGRAM OVERVIEW
- CONDUCT PERIODIC WORKSHOPS/PROGRAM REVIEWS

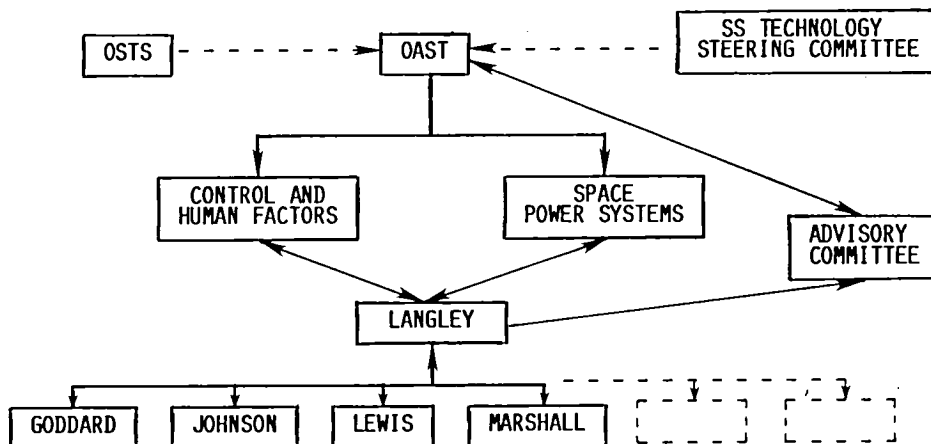

Figure 13

## REFERENCES

1. Notti, J. E.; Cormack, A., III; and Schmill, W. C.: Integrated Power/Attitude Control System (IPACS) Study, Volume I - Feasibility Studies. NASA CR-2383, April 1974.
2. Notti, J. E.; Cormack, A., III; Schmill, W. C.; and Klein, W. J.: Integrated Power/Attitude Control System (IPACS) Study, Volume II - Conceptual Designs. NASA CR-2384, April 1974.
3. Will, R. W.; Keckler, C. R.; and Jacobs, K. L.: Description and Simulation of an Integrated Power and Attitude Control System Concept for Space-Vehicle Application. NASA TN D-7459, April 1974.
4. Anderson, Willard W.; and Groom, Nelson J.: The Annular Momentum Control Device (AMCD) and Potential Applications. NASA TN D-7866, 1975.
5. Ball Brothers Research Corp.: Annular Momentum Control Device (AMCD). Volumes I and II. NASA CR-14417, 1976.



**Page intentionally left blank**

POWER SYSTEM CONSIDERATIONS AND TEST ACTIVITIES

Jim Miller  
Marshall Space Flight Center  
Huntsville, Alabama

## IPACS POWER SYSTEM GROUND RULES

This chart details the ground rules used in evaluating the overall IPACS potential system performance as detailed in succeeding charts.

- POWER REQUIREMENTS

DAY            50KW (USER) + 28KW (SUB-SYS) = 78KW

NIGHT         50KW (USER) + 18KW (SUB-SYS) = 68KW

- ORBIT

DAY            .97 HRS

NIGHT         .6 HRS

- DISTRIBUTION (BASELINE)

135 VDC

2% REGULATION

- GIMBALS (2) INCLUDED FOR CMG

## FLYWHEEL ENERGY STORAGE SYSTEM

This chart shows the system block diagram for the IPACS. Power requirements at points along the system were calculated by working back from the user and subsystem busses. During darkness, all power is generated by the IPACS by drawing off 56 kW-hr of energy in .6 hrs. During daylight, the array generates enough power to maintain the user and subsystem busses as well as adding 56 kW-hr of energy in .97 hrs. to the wheel. Analyses of typical NiCd and Regen Fuel Cell Systems resulted in array power requirements as shown on the chart.

(DAY/NIGHT)

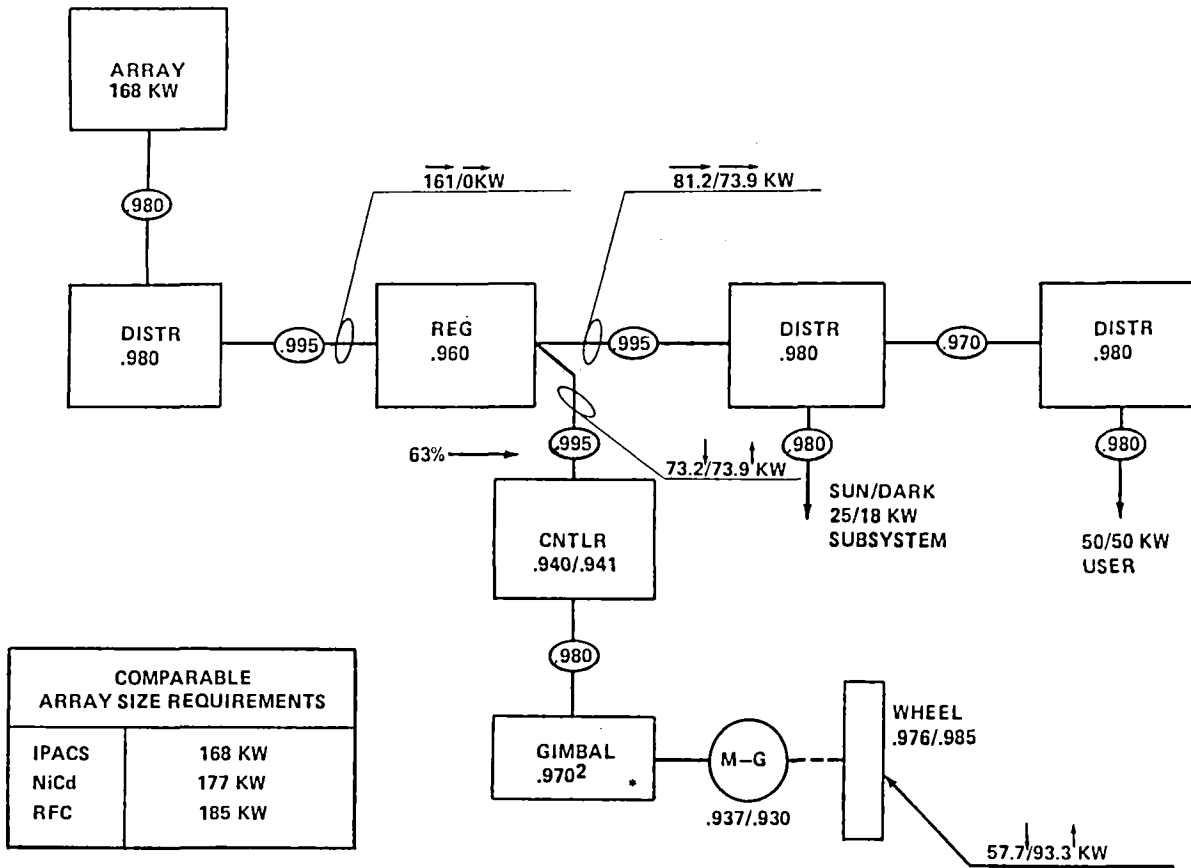

WHEEL ENERGY = 56 KW - HR

\* .97 TO .999 RANGE

## POTENTIAL IPACS SYSTEM PERFORMANCE

This chart summarizes the potential performance of the power system using an IPACS storage system. Efficiencies were calculated by using energy in and out rather than power to account for different charge/discharge times.

- END-TO-END SYSTEM ENERGY EFFICIENCY (1 ORBIT) 43.1%

- REQUIRED ARRAY SIZE - 168KW

- WHEEL ENERGY STORED 56 KW-HR

CHARGE AT 57.7KW FOR .97HR

DISCHARGE AT 93.3 KW FOR .6 HR

- FLYWHEEL/CONTROLLER POWER EFFICIENCY (W/O GIMBALS)

CHARGE 86%

DISCHARGE 86.2%

- ROUND TRIP IPACS (W/GIMBALS) ENERGY EFFICIENCY 62.4%

IPACS ISSUES/QUESTIONS  
FOR R&T PROGRAM

This chart lists the issues and questions which need to be addressed to produce a viable IPACS system. Although some topics do lend themselves to a certain degree of analysis, it is felt that the major thrust must be through an R&T program involving a significant test effort.

- INTERACTION OF ATTITUDE CONTROL & ENERGY STORAGE FUNCTIONS - CAN THEY BE COMBINED & ARE EXISTING CONTROL LAWS ADEQUATE AS STARTING POINT
- PERFORMANCE OF MOTOR-GENERATOR AND ELECTRONICS
- RELATIVE MERITS OF AC/DC MOTOR-GENERATOR COMBINED WITH AC/DC DISTRIBUTION SYSTEMS
- VOLTAGE LEVEL - 135V OR 270V OR INTERMEDIATE
- FREQUENCY OF AC DISTRIBUTION - 400 HZ OR 20 KHZ OR OTHER
- MANAGEMENT PHILOSOPHY OF MULTI-UNIT STORAGE SYSTEM
- POWER/IPACS UNIT - 6KW OR OTHER
- INTEGRATION OF FLYWHEEL ELECTRONICS (LO & HI RPM) WITH PRIME CANDIDATE DISTRIBUTION SYSTEMS
- TYPE OF POWER TRANSFER DEVICE - SLIP/ROLL RINGS, FLEX WIRE OR OTHER
- FLYWHEEL MATERIAL/DESIGN - SUSPENSION TYPE, MAGNETIC/BEARINGS
- NEED FOR ANY SEPARATE ATTITUDE CONTROL CAPABILITY
- TYPE OF ATTITUDE CONTROL - CMG OR REACTION WHEEL

## IPACS R&T PROGRAM

This chart shows the top level technology areas to be addressed and the phasing of these areas. This would basically be an R&T program until such time as testing was focused on a specific application such as Space Station when funding responsibility would fall to the appropriate program. It is felt that a technology ready date consistent with present Space Station schedules is possible if the program is begun in the very near term.

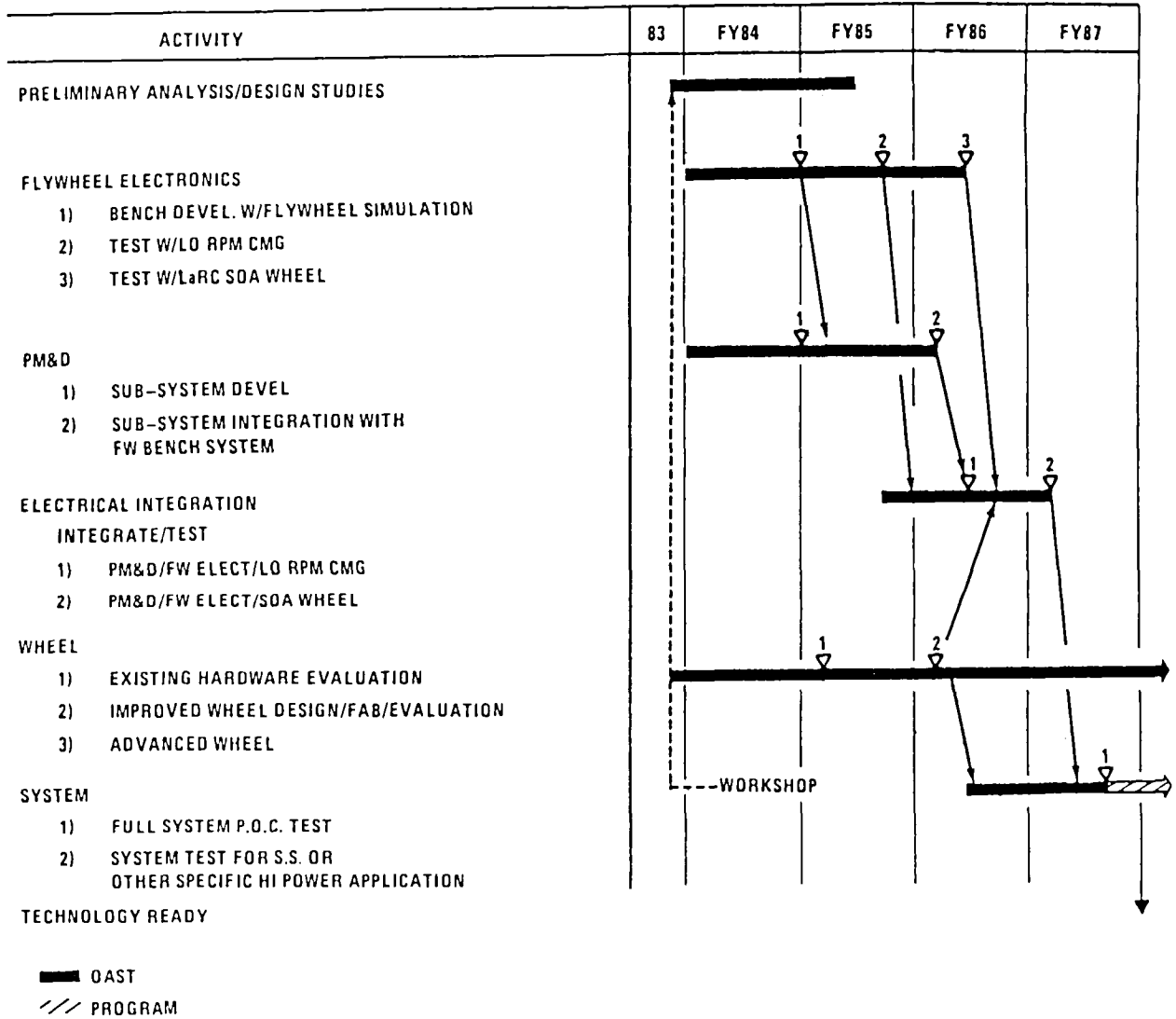

## IPACS MSFC RESOURCES

This chart lists the various MSFC test facilities and resources which are now available or will be available under Space Station advanced development programs.

- HIGH VOLTAGE ELECTRIC POWER SYSTEM BREADBOARD
- MULTI-100KW POWER SYSTEM BREADBOARD
- MOTOR/CONTROL ELECTRONICS DEVELOPMENT LAB
- MOMENTUM STORAGE TORQUER TEST FACILITY
- PROPOSED SPACE STATION ADVANCED DEVELOPMENT TEST BED
  - \* POWER
  - \* GN&C



## IPACS POTENTIAL BENEFITS

This chart summarizes the potential benefits of an IPACS system compared to NiCd and/or Regen Fuel Cell Systems.

- SIGNIFICANT LIFE CYCLE COST SAVINGS
- TOTAL WEIGHT-TO-ORBIT SAVINGS (30 YRS) AS MUCH AS 10 TIMES
- END-TO-END EFFICIENCY INCREASE RESULTS IN ~ 10 KW REDUCTION IN ARRAY SIZE(6%)
- MOTOR/GENERATOR CONTROLLER REGULATION DURING DISCHARGE SIMPLIFIES DISTRIBUTION SYSTEM
- MOMENTUM STORED FOR ATTITUDE CONTROL INCREASED BY 4 TIMES

IPACS GUIDANCE NAVIGATION AND CONTROL  
SYSTEM CONSIDERATIONS AND  
TEST ACTIVITIES

H. J. Buchanan  
Marshall Space Flight Center  
Huntsville, Alabama

The MSFC facility proposed for the Space Station Attitude Control Simulator consists of a large three degree of freedom table driven by computer controlled hydraulic actuators designed to give high bandwidth and extremely fine control through large angles. By compensating for the earth's rotation and programming the dynamic characteristics of the station into the facility computer, the table can be made to respond dynamically as if it were an orbiting Space Station. Then by mounting attitude sensors and actuators on the table and tying them to a control computer the table's attitude can be controlled closed-loop. Three Control Moment Gyros are currently mounted on the table along with rate gyros, a solar aspect sensor, and star tracker. The facility includes star and solar simulators providing collimated light with the spectral content and intensity typical of earth orbit. Hybrid computers are interfaced with the facility for the modeling of environmental torques and structural dynamics. Collocated with the table is a fine pointing system which can be used to simulate station mounted pointing systems. Much of the control system software and environmental torque models necessary for this high fidelity simulation are already developed and adaptation of these models to the hybrid facility computer is partially complete.

#### GN&C TEST BED OBJECTIVES

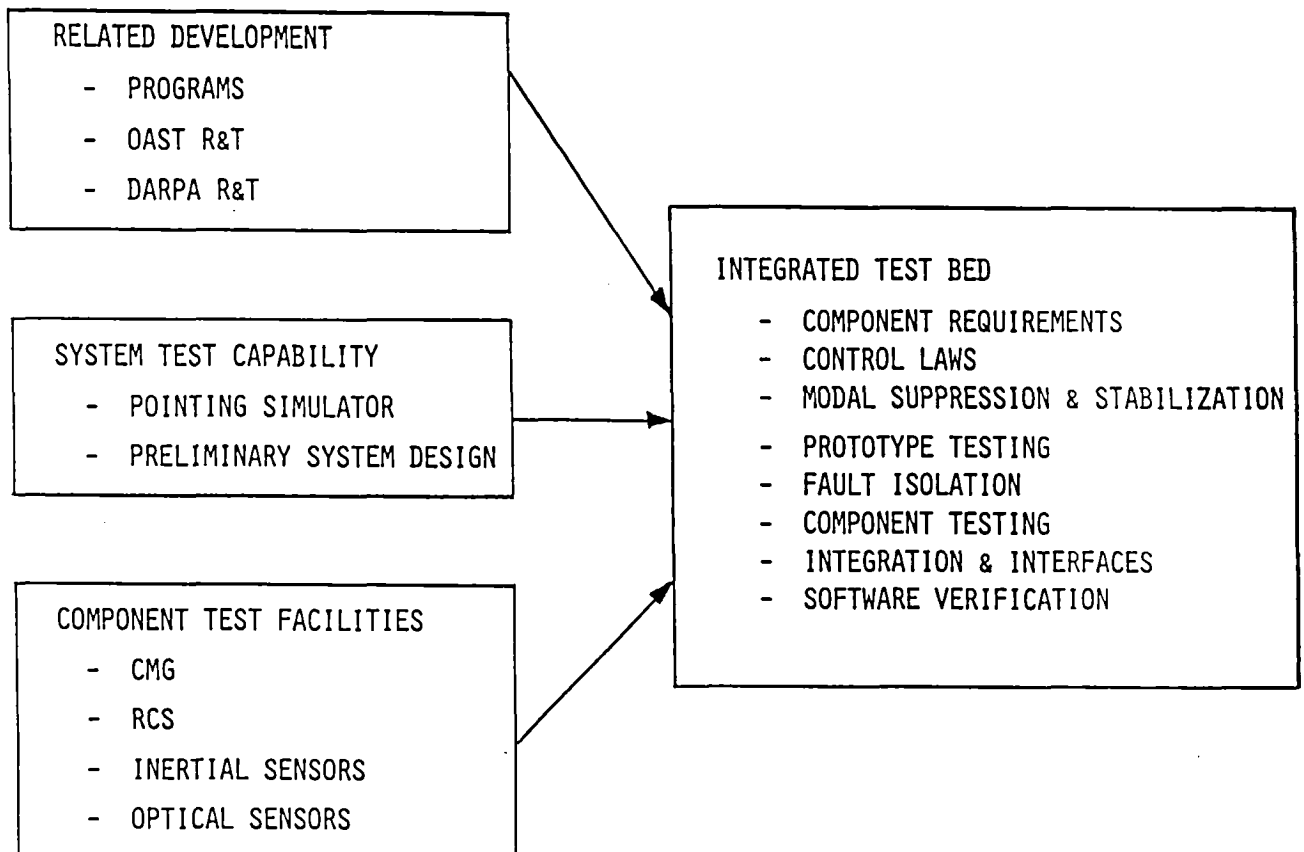

Planning for this test bed should at the outset consider the evolving nature of the Space Station and provide the capability for performing component tests, simulations, and system level evaluations on a wide variety of technological items. The environment, the dynamics of the structure, on-board disturbances, and similar effects must be simulated by the test bed facility computer in order to provide realistic test conditions. Likewise, the test bed should be capable of accommodating a wide range of control actuators, sensors, and the implementation of control strategies of varied complexity. Also, the GN&C system is expected to set many of the requirements for the data management system, and the interaction with both crew and ground operation systems will be important. Thus, the test bed should explore and expose potential problems at the system level early so corrective procedures and controls can be put in place.

### GUIDANCE NAVIGATION AND CONTROL TEST BED STRUCTURE

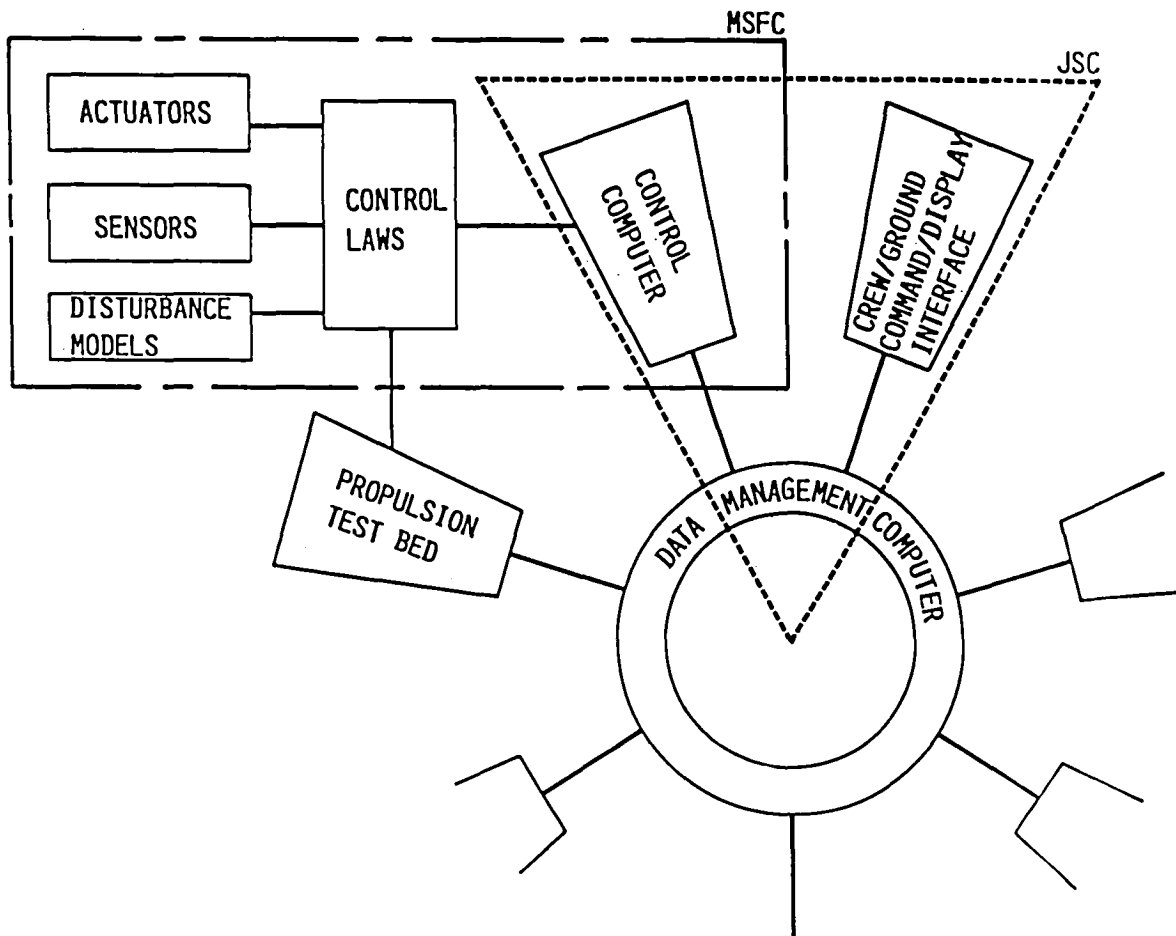

A plan for managing this effort is included in the figure. Comanagers, one from MSFC and one from JSC, will be responsible for scheduling and coordinating the activity under guidance from the Space Station project. An advisory group with membership from other centers, headquarters, and center management will review the activity and make recommendations. The GN&C test bed will be horizontally coordinated with other advanced development test beds so that interface system requirements can be coordinated efficiently. Finally, the technical work encompassed by the test bed itself can be grouped in four major categories (component technology, hardware simulation, analysis and trades, and software integration). At MSFC a lead individual responsible for each area will be drawn from the cadre of GN&C technologists who developed, tested, and provided on-orbit support to the Skylab vehicle.

### SPACE STATION ATTITUDE CONTROL SYSTEM SIMULATOR

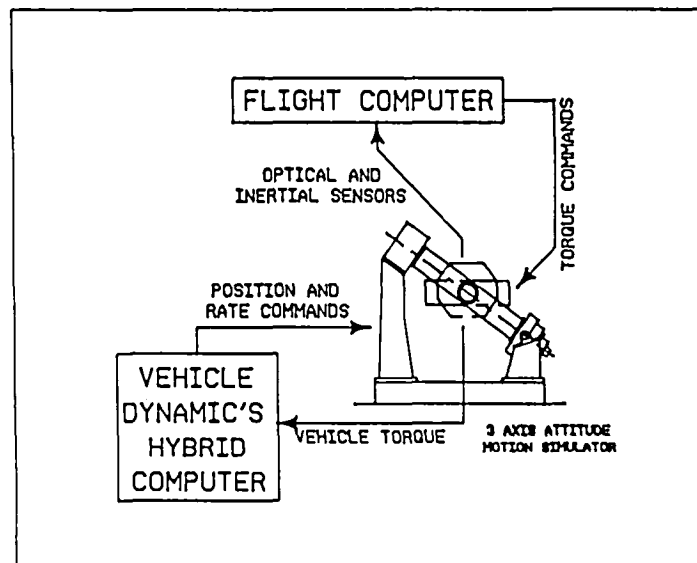

#### THE ATTITUDE CONTROL SYSTEM SIMULATOR CONSISTS OF:

- A LARGE 3 DEGREE OF FREEDOM TABLE POWERED BY HYDRAULIC ACTUATORS DESIGNED TO GIVE HIGH BANDWIDTH AND EXTREMELY FINE CONTROL THROUGH LARGE ANGLES
- COMPENSATION FOR EARTH ROTATIONAL RATE
- CONTROL MOMENT GYRO'S
- STAR TRACKER
- RATE GYRO'S
- STAR SIMULATOR AND SOLAR SIMULATOR PROVIDING COLLIMATED LIGHT HAVING THE SPECTRAL CONTENT AND INTENSITY RECEIVED IN EARTH ORBIT

#### THE CONTROL SYSTEM SIMULATOR INCLUDES A 3 DEGREE OF FREEDOM POINTING MOUNT TABLE

- SEVERAL MISSIONS REQUIRE POINTING MOUNTS
- POINTING MOUNT CONTROL WILL BE HIGHLY INTERACTIVE WITH SPACE STATION CORE CONTROL AND WITH THE DYNAMICS OF THE STRUCTURE

#### ATTITUDE CONTROL SYSTEM SIMULATION ACTIVITIES

- DEVELOPING A REAL TIME HYBRID SIMULATION OF THE SPACE STATION DYNAMICS AND THE ENVIRONMENT
- EVALUATION OF THE DYNAMIC CHARACTERISTICS OF THE ATTITUDE CONTROL SYSTEM AND THE NEW MOMENTUM MANAGEMENT CONTROL LAW
- EVALUATION OF FAULT ISOLATION AND REDUNDANCY MANAGEMENT TECHNIQUES
- EVALUATION OF MODIFIED AND IMPROVED COMPONENTS SUCH AS CMG'S AND RATE GYRO'S
- EVALUATION OF THE TRADE BETWEEN FINE BODY POINTING, FINE POINTING MOUNTS, AND FREE FLYERS
- INTEGRATION AND VERIFICATION OF INTERFACES BETWEEN CONTROL COMPONENTS AND SOFTWARE

FLYWHEELS FOR DYNAMIC SYSTEMS

Luther W. Slifer  
NASA Goddard Space Flight Center  
Greenbelt, Maryland

Although the primary considerations for the near term are logically related to photovoltaic space power systems, we should not totally ignore the potential future use of dynamic systems where conversion is accomplished using high speed rotating machinery. The energy source for such systems may be either solar or nuclear. Flywheel applications in these cases would accomplish the dual function of momentum control and load leveling. Momentum control would be necessary to compensate for the angular momentum of the rotating machinery. Load leveling would be necessary since it would not appear desirable to adjust the speed of the turbines, compressors, and generators to suit variable loads, nor possible in the case of peak loads exceeding generating capacity. Both of these needs are, of course, significantly greater in the case of the solar-dynamic system, where satellite eclipse would significantly affect system operations, as compared to the nuclear-dynamic system which would be relatively unaffected by eclipse.

## DYNAMIC POWER GENERATION-ROTATING MACHINERY

SOLAR

NUCLEAR

## NEED FOR FLYWHEELS

MOMENTUM CONTROL

LOAD LEVELING

ASSESSMENT OF POTENTIAL FOR BATTERIES  
IN SPACE APPLICATIONS

F. E. Ford  
NASA Goddard Space Flight Center  
Greenbelt, Maryland



With the advancement of higher power missions (25 to 100 kW), the system designer must look beyond existing battery technology for energy storage. After careful review of the present status quo, one could raise serious questions as to the viability of any battery system for these future missions. One of the best ways to determine what may be possible with high-energy-density batteries is to look at what has been achieved with more conventional batteries (i.e., lead-acid, nickel-cadmium, nickel-hydrogen, etc.). Table I illustrates the theoretical specific energy density for state-of-the-art batteries and the usable energy density for a reasonable life expectancy. The most mature of these couples is lead-acid, which achieves nearly 20 percent of its theoretical capacity. The nickel-cadmium couple, which is the best battery known to date in terms of cycle life, has matured to where the active capacity is 17 percent of its theoretical capacity. These achievements can be used as a measure of what may be practical for more advanced batteries and to estimate what is needed for future high-power space systems. A guide is available for determining which couples should be pursued to meet the future needs.

TABLE I  
SPECIFIC ENERGY OF TYPICAL ELECTROCHEMICAL SYSTEMS

	Theoretical		Actual		Actual/ Theoretical
	Potential (volts)	Specific Energy (Wh/kg)	Potential (volts)	Specific Energy (Wh/kg)	Percentage
Pb-acid	2.095	175	1.95	35	20
Ni-Cd	1.29	222	1.25	37	17
Ag-Cd	1.38/1.15	267/191	1.18/1.04	70	31
Ag-Zn	1.856/1.602	434/273	1.65/1.40	100	28
Ni-H <sub>2</sub>	1.358	378	1.30	48	13
Ag-H <sub>2</sub>	1.398	523	1.10	70	13

A projection for future need can be made utilizing a 20-percent factor for the practical to theoretical specific energy density. Assuming that a specific energy density of 100 Wh/kg is required to meet the high-energy objectives, an electrochemical power source with a theoretical energy density of greater than 500 Wh/kg would be required. The capabilities of a few advanced high-energy systems are summarized in Table II.

Using the above criteria, the ambient temperature of zinc/halogen (Zn/X<sub>2</sub>) systems with energy densities of 420 and 461 Wh/kg would be marginal for the high-power missions. The sodium/sulfur (Na/S) system suffers from high resistivity and fragility of components but has a very high specific energy (728 Wh/kg), 20 percent of which is four times the energy available in the present systems. Of the two lithium/metal sulfide (Li/MeS) couples described, the Li-Si type has a 944 Wh/kg theoretical energy density, almost five times the energy of present systems. The prismatic cell design utilized for this couple could be advantageous although there has been limited development with this system.

In short, the two groups, ambient-temperature Zn/Cl<sub>2</sub> and Zn/Br<sub>2</sub> and high-temperature Na/S and Li/MeS, have potential for high-power space use. However, until this time the emphasis for these systems has been directed toward terrestrial use. With a requirement of aerospace applications, these systems can be improved for use in future 50- to 100-kW long-life space missions.

TABLE II  
SPECIFIC ENERGY OF HIGH ENERGY ELECTROCHEMICAL SYSTEMS

	Theoretical		Actual				
	Potential (volts)	Specific Energy (WH/kg)	Potential (volts)	Sizes (Ah)	Operat. Temp. (°C)	Specific Energy (Wh/kg)	Cycles
<u>High Temperature</u>							
Na-βAl <sub>2</sub> O <sub>5</sub> -S	2.08	758	1.60	165	350	150	200/1500
Na-NaGlass-S	2.08	691	1.88	40	300	132	500
LiAl-LiCl-KCl-FeS	1.33	458	1.30	320	450	100	300
Li <sub>4</sub> Si-LiCl-KCl-FeS <sub>2</sub>	1.80/1.30	944	1.80/1.30	1.20	70	450	120 700
<u>Ambient Temperature</u>							
Zn-Cl <sub>2</sub>	2.12	461	1.95	50KWH	AMB	71	1000
Zn-Br <sub>2</sub>	1.82	428	1.60	20	AMB	61	1800
NASA Redox (Fe <sup>2+</sup> /Fe <sup>3+</sup> -Cr <sup>3+</sup> /Cr <sup>2+</sup> )	1.08	101	0.90		AMB		3000

**Page intentionally left blank**

SOME COMMENTS ON LONGEVITY BY A TECHNOLOGIST

Larry H. Thaller  
NASA Lewis Research Center  
Cleveland, Ohio

The impression is given that flywheels will last forever, or almost forever. Based on my knowledge of the DOE program in particular and other fields of technology in general, I feel this will just not be the case. Since only composite flywheels possess the potential for system energy densities in the range of 20 to 40 W hr/kg, and they are not yet at a level of maturity where a comfortable data base exists, one is forced at this point to speculate on the longevity aspects of these yet-to-be-developed devices. The following group of charts will outline the general methodologies that have been used in some of the more established technology areas in an effort to establish some degree of credibility in being able to predict the upper limits of expected useful life based on the current limiting decay mechanism.

If we can roughly categorize people into those who are program related and those who are technologists, there then emerges a natural division of interest related to life. The technologist often has the job of meeting a certain life requirement. Life and performance are often interrelated by a factor that in turn is related to intensity or stress. Life is for the most part a function of some stress or intensity in a continuous manner. By understanding this basic interrelationship, the technologist is able to do two things. First of all he or she is able to suggest a degree of stress or intensity that will result in a given useful life. Within this framework a certain fixed useful life for a technology does not exist; there is a continuum of lives dependent upon the stress level of use. Second and more important, a concerted effort can be made to reduce the rate of performance loss, or in some other way affect the interrelationship between useful life and stress. As improvements in technology come about, new life vs. stress relationships are developed. Very often as improvements in one area are made, a new critical decay phenomenon appears and it then becomes the focus of attack by the technologists in that field. Very few fields are static in terms of projected lives vs. stress level of use. The following four figures suggest that the basic decay modes of these four areas of technology, if not fully understood, can be modeled with a certain degree of accuracy.

## ON THE QUESTION OF LONGEVITY

- 1) THE PROGRAM PERSON ASKS "HOW LONG DOES A PIECE OF EQUIPMENT LAST?"
  - 2) THE TECHNOLOGIST ASKS "HOW LONG SHOULD A PIECE OF EQUIPMENT LAST?"
- 0 ALTHOUGH BOTH QUESTIONS ARE IMPORTANT, THE ANSWERS MAY BE VERY DIFFERENT
- 0 THE PROGRAM PERSON COULDN'T CARE LESS ABOUT THE ANSWER TO THE SECOND QUESTION
- 0 THE TECHNOLOGIST MAKES HIS LIVING NARROWING THE GAP BETWEEN THE TWO

In well-behaved single cells the number of useful cycles is generally related to the depth of discharge (stress level) in a semi-log fashion as illustrated. It is not the intent of this chart to summarize all the cycle life studies of all alkaline cells. The main purpose of this chart is to indicate the general trend of the life vs. stress relationship and show that there are a number of these relationships that are vertical translations of one another. Without trying to present a comprehensive dissertation on the decay mechanisms of these devices, it can be said that there is a gradual loss of capacity due to the cumulative effects of morphological changes within the electrodes. The effect of temperature on the chemically unstable separator (pellon) is clearly evident.

Lower temperatures which reduce the rate of attack on the material are favored. Likewise chemically resistant materials as replacements for the pellen are beginning to show their potential usefulness. The Ni-H<sub>2</sub> lives are currently not supported with too much data since there appear to be other problems in current designs. It is speculated that since the cadmium electrode is less well behaved than the nickel electrode, that Ni-H<sub>2</sub> cells should have longer cycle lives. Where some laboratory data are available to support the positioning of the lines, data points appear on the lines. Where only modeling and projections are available, no data points are used. In conclusion, we can see that with alkaline cells, there exist a number of discrete life vs stress relationships and within any one relationship there is a continuum of life vs stress level values.

### ALKALINE BATTERY DECAY MODELING

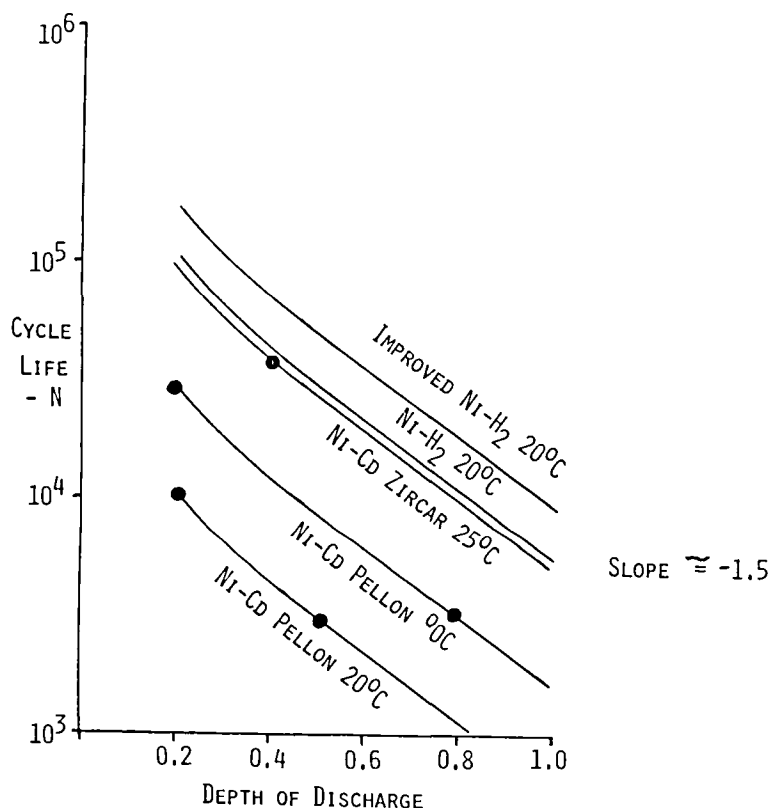

Probably the best documented decay modeling available comes from information generated by the General Electric Co. It is generally accepted that the peroxide intermediate at the oxygen electrode chemically attacks the molecular linkages of the Nafion membrane. Since this would be highly temperature sensitive, the stress factor is temperature rather than current density. The attack of this problem is related to efforts to reduce the concentration of peroxide at the oxygen electrode as well as efforts to improve the membrane in terms of its resistance to attack by peroxide. The three lines showing three "vintages" of technology show the results of some fifteen years of work. The confidence in being able to vertically translate the lines of improved technology is the only basis by which one can credibly project the useful life at low stress levels where projected lifetimes are on the order of years.

### ACID SPE FUEL CELL DECAY MODELING

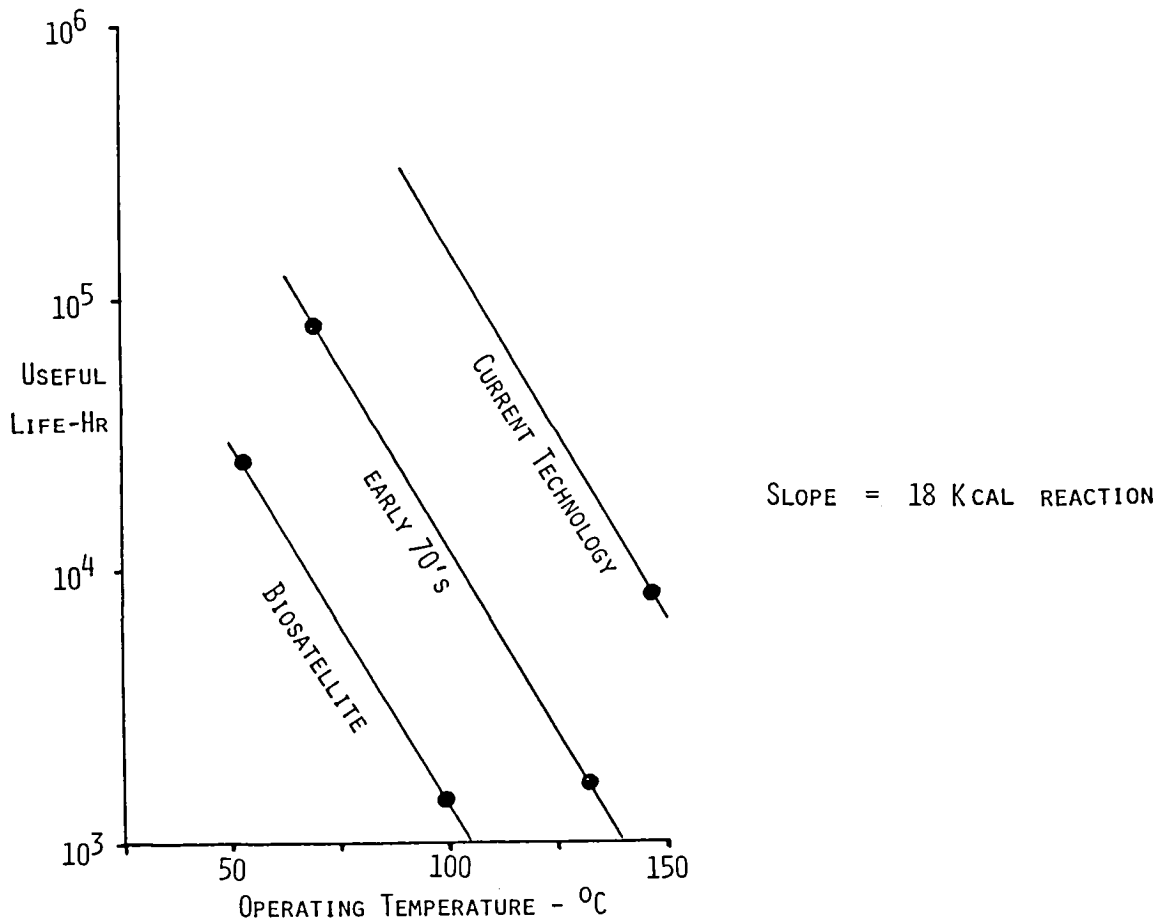

The generally accepted decay mechanism associated with alkaline fuel cells is the gradual buildup of the carbonate level within the trapped electrolyte content of the cell. This buildup is accompanied by a reduction in electrolyte conductivity and volume. The attack on this problem by the technologists has been directed to 1) designing cells that are more tolerant to changes in electrolyte volume and 2) developing plastic components that are more resistive toward oxidation. Here the major stress factor is current density since small traces of carbon dioxide are generally present as impurities in the otherwise pure reactant gases. Temperature is an important parameter also. There is always a desire to go to higher temperatures but that has to be tempered by the requirement to meet a design life. Here again, the useful life vs. stress level is a continuum and advanced technology efforts have resulted in the vertical translation of the life vs. stress line. As in the other charts, data points have been added where they exist and their absence indicates that the position of the line is based on a combination of projection and speculation.

### ALKALINE FUEL CELL DECAY MODELING

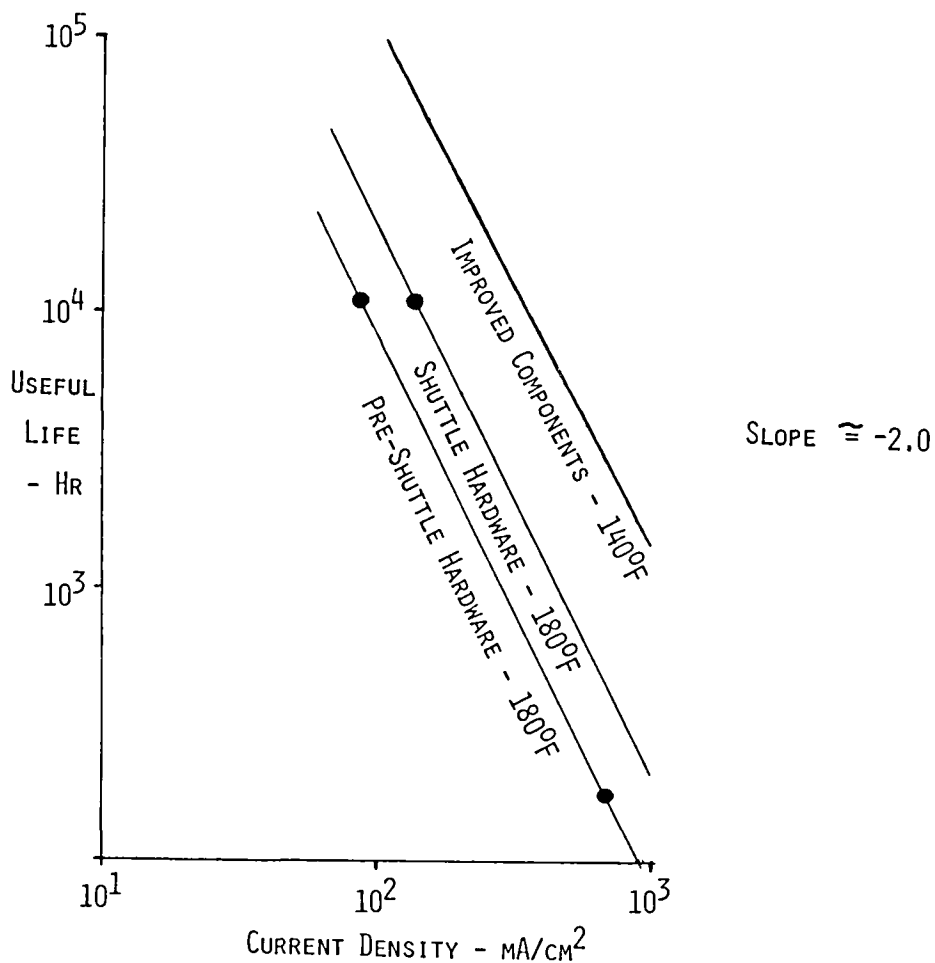



With the advent of composite materials, renewed interest has developed in flywheel energy storage systems. Composite materials make it possible to develop a flywheel with very high theoretical energy density. As with other systems, certain parameters can affect the lifetime. Some of the parameters to be considered are low and high temperature fatigue, creep and radiation damage. The effect of operating a composite flywheel rotor at higher than ambient temperature is shown in the accompanying figure. The lines were drawn using a 15 year operating life at ambient temperature as the reference point. Fatigue behavior of the fiber composites was analyzed for the three systems shown on the figure. The shallow slope of the graphite/epoxy composite can be attributed to the good heat dissipation capability of graphite. The importance of the matrix and of the fiber-matrix bond should be considered in composite flywheel decay modeling. The relative positions of the curves in the figure will change depending on the choice of fiber and matrix. Only long term experimental tests will show which composite systems achieve the best performance in a flywheel application.

### COMPOSITE FLYWHEEL DECAY MODELING

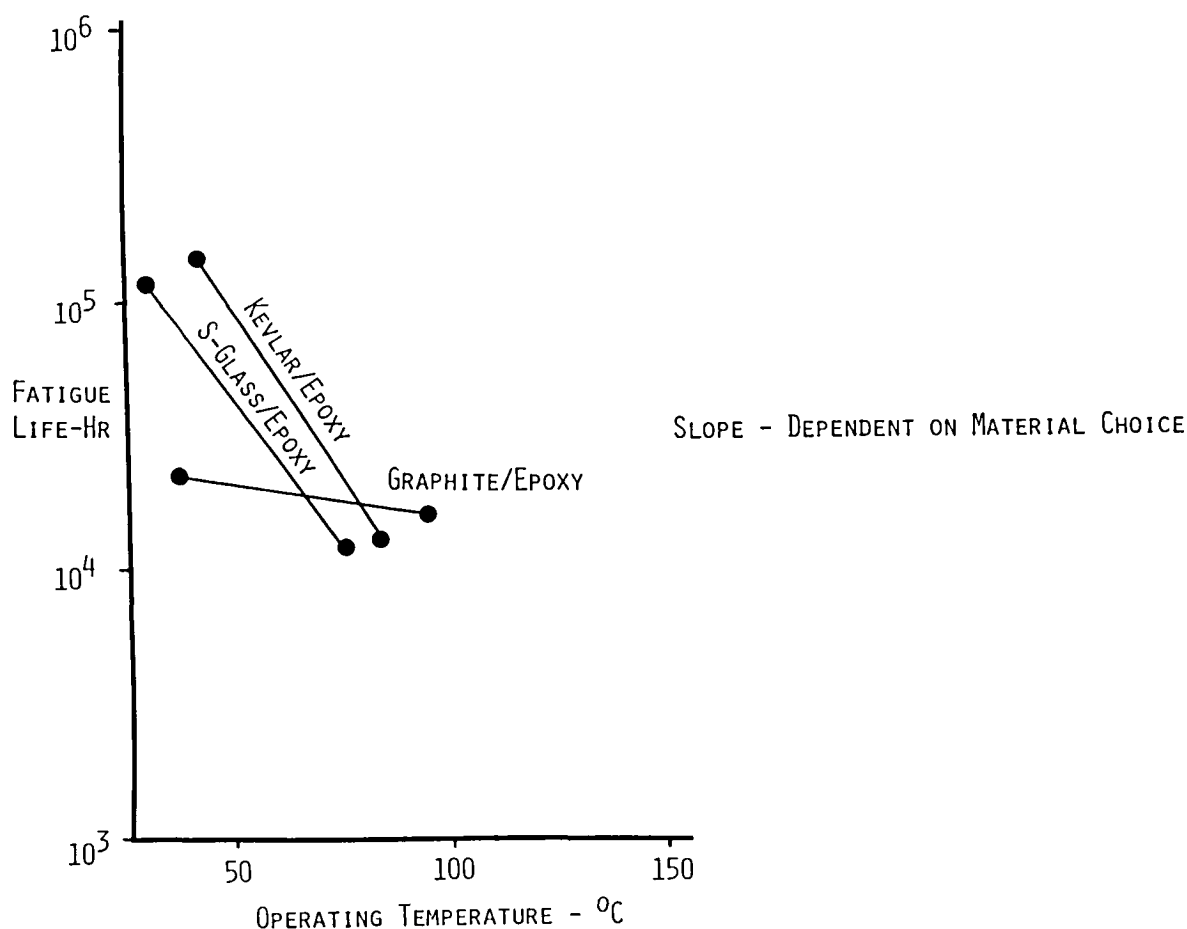

These statements, although somewhat glib and flippant in nature, do carry a great deal of truth. Very often an item is designed and manufactured for a certain application in the most cost effective manner. The expected life of that item should in no way be considered to be the ultimate life of all classes or types of that item. The life expectancy of a car designed as a race car is much different than that of one designed for highway driving. And even within these two "vintages" of technology there is a generally accepted life vs. stress relationship. It is only as one understands these relationships that one fully appreciates the full potential as well as the limitations of a particular technology.

I asked a technologist a question in his field of expertise. He told me that five years ago he knew all the answers in his field, but at this point in time there are many things he is not too sure about.

## **THE ULTIMATE DISTILLATION OF ALL FAILURE AND PERFORMANCE DECAY MODELING**

- O ANYTHING CAN PRETTY MUCH BE MADE TO LAST HOWEVER  
LONG IT NEEDS TO LAST - IF YOU ARE WILLING TO PAY  
THE PRICE
  
- O THERE IS NO SUCH THING AS A FREE LUNCH

Historically, battery energy storage subsystems consist of groupings of single cells. The more advanced electrochemical technologies are not intended to be simply groupings of single cells with higher energy densities than nickel cadmium cells. Advanced electrochemical storage concepts, in part, try to circumvent the problems that are associated with contemporary battery concepts. By incorporating active cooling into the electrochemical cells and having a degree of commonality of reactants between all the cells, storage concepts that are quite different from the traditional battery pack are possible and indeed are being worked on. The electrochemical technologist does not see his job as making a better Ni-Cd cell, but as revolutionizing the methods used to design and develop electrochemical storage systems.

### THREE DIFFERENT CLASSES OF ELECTROCHEMICAL STORAGE SYSTEMS

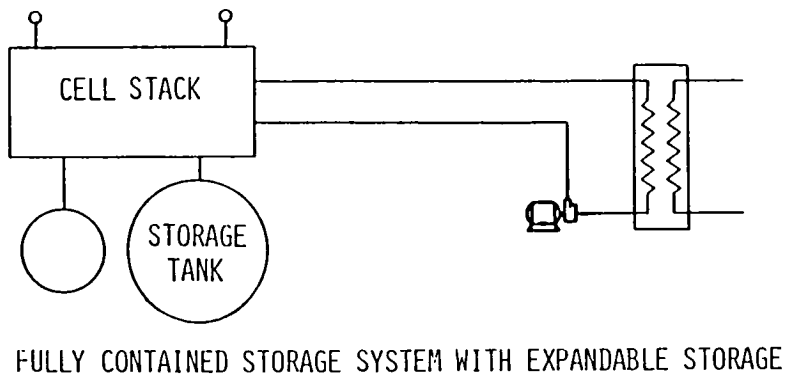
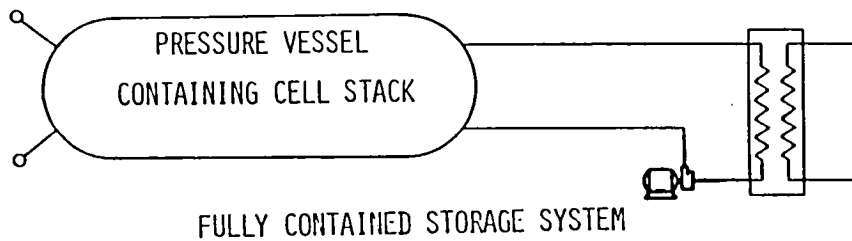
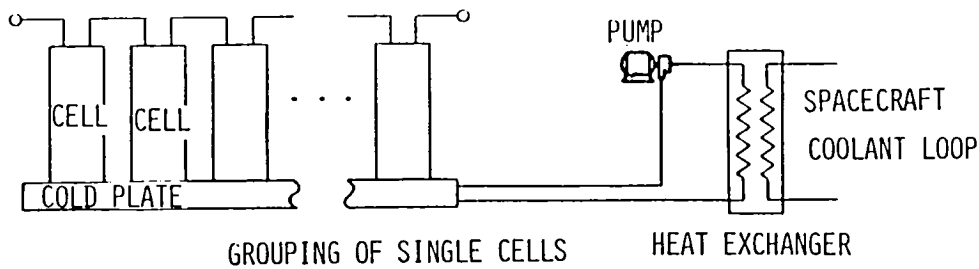

This chart is intended to place within a consistent framework the projected energy densities of most of the battery concepts that are currently being worked on. Where it is my own personal opinion that a technology does not represent a viable contender for consideration at this point in time, a dash appears under the column for projected useable energy density. It should be noted that energy densities are projected only to the nearest 5 Wh/kg. For comparison we would suggest a number of 25 Wh/kg for a flywheel system. By system we mean wheel, motor/generator, mounting, and a noncontaining case. Of course, no gimbaling is included. Flywheels indeed do have an attractive energy density based on current weight projections. A firm basis for projecting the life vs. stress relationship for this concept does not appear to have been agreed upon or firmly established as yet so that proper life projections can be made.

## PROJECTED ENERGY DENSITIES OF ELECTROCHEMICAL STORAGE DEVICES FOR LARGE LEO APPLICATIONS

BATTERY PACK TYPES	USABLE ENERGY DENSITY WHR/KG	SYSTEM TYPES	USABLE ENERGY DENSITY WHR/KG
Ni-H <sub>2</sub> IPV CPV, 50% DOD	20	H <sub>2</sub> -O <sub>2</sub> RFC EFF OPT WT OPT	30 55
Ni-Cd                   25% DOD	10	Ni-H <sub>2</sub> BIPOLAR	35
Na-S 300°C           80% DOD	100	H <sub>2</sub> -Br <sub>2</sub> RFC	80
Ag-H <sub>2</sub> IPV CPV	-	H <sub>2</sub> -Cl <sub>2</sub> RFC	-
Na-X 200°C	-	Zn-Br <sub>2</sub>	-
Li-FeS 400°C	-		
Li-X Non Aq	-		

At the Lewis Research Center we try to look at all the major components of the power system. The storage part of that overall system is currently very large (Ni-Cd batteries). The more advanced electrochemical systems have the potential for reducing the overall weight. Flywheels, of course, are also attractive in that regard. It is viewed by some that by combining the storage function with the attitude control function, their usefulness can be compounded. The fuel cell water electrolyzer advocates suggest that a regenerative fuel cell could be integrated into the life support function of a Space Station and could use residual propellants as reactants in the fuel cell. This would magnify its potential usefulness. There appears to be no simple answer to many of the current Space Station questions. It would help, of course, to have a credible data base in all these areas.

## POWER SYSTEM MASS BREAKDOWN BY MAJOR SUBSYSTEM

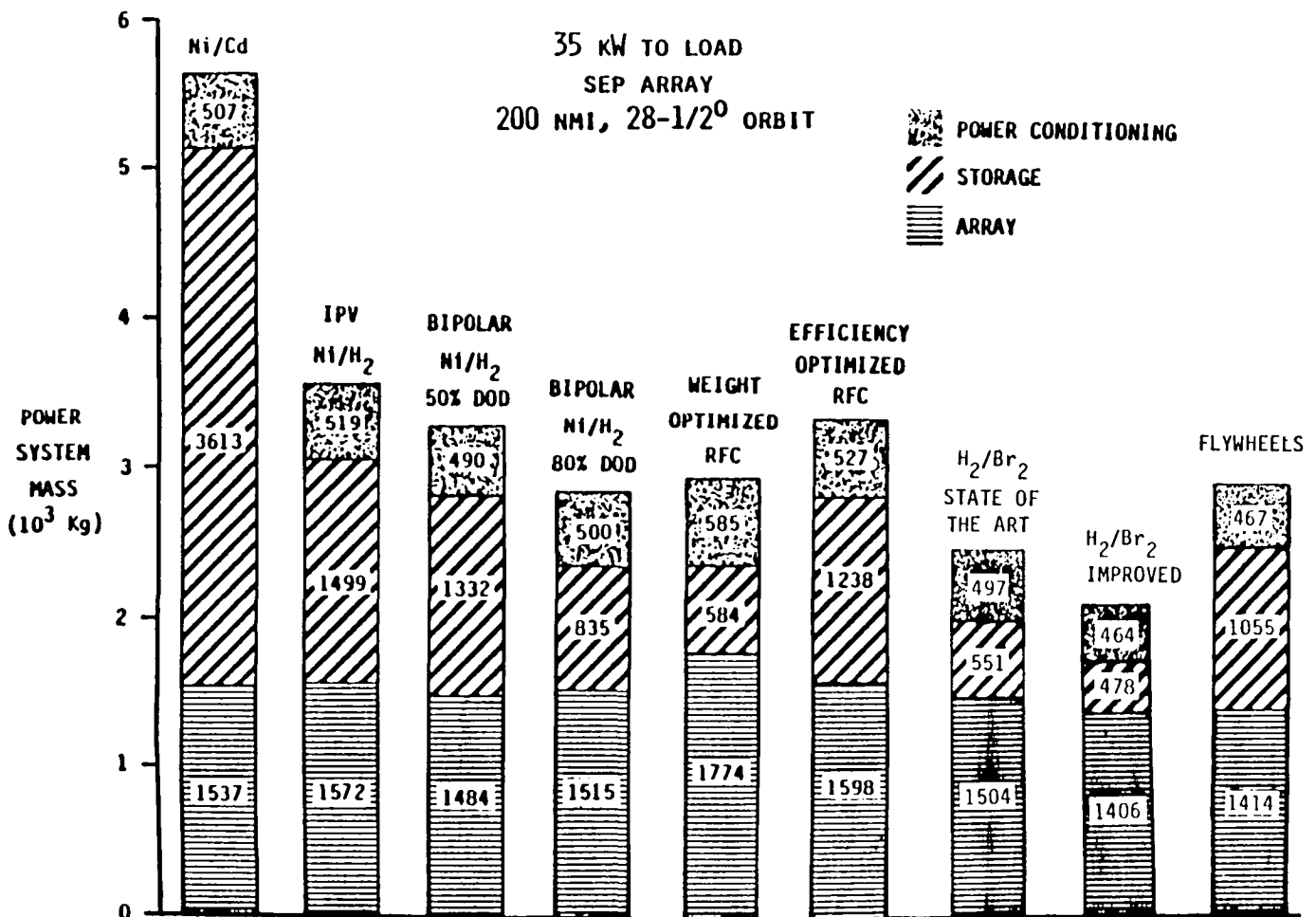

Considering the relative infancy of the technology in question (composite wheel, magnetic bearing, and a motor/generator all in one package) there is a wide variety of areas that need attention. It would appear to me that the critical technology is related to the strength, life, performance, etc. of the composite wheel itself. The four points on the accompanying chart are listed in this light.

The subject of what really is the competition for flywheels is a good one. Unfortunately that topic was not addressed in much detail at the meeting. If flywheels are considered to be an "advanced" technology, they should be compared to other "advanced" storage technologies. I don't feel that Ni-Cd or RFC based on H<sub>2</sub> and O<sub>2</sub> represent the competition.

The area of suitable containment is one that has not been addressed very well. It is contended that composite wheels "fluff" at failure and thus don't present too much of a problem. However, if one has, say, a 5 kW hr wheel let go, then somehow about 7 kW hr of energy must be absorbed, dissipated, expelled, or in some other way be converted from one form of energy to another. For example, 7 kW for one hour doesn't appear to be an overly large dissipation rate, but if it were done within a one second time frame the power level would be 25 megawatts. It is very difficult to have a graceful explosion.

It is imperative to develop a proper life vs. stress relationship to help in attacking the critical technology areas as well as develop a credible technology base and life projection methodology.

It would appear that these factors will be highly important in fixing the vertical positions of the various vintages of life vs. stress relationships.

## AREAS THAT NEED TO BE ADDRESSED

- 0 WHAT IS THE COMPETITION AGAINST WHICH FLYWHEEL ENERGY STORAGE MUST COMPETE?
- 0 WHAT WILL REPRESENT A SUITABLE CONTAINMENT PROVISION?
- 0 WHAT IS THE PROPER LIFE VS. STRESS INTERRELATIONSHIP FOR COMPOSITE FLYWHEELS?
- 0 WHAT IS THE EFFECT OF ULTRA VIOLET OR OTHER RADIATION AND ELEVATED TEMPERATURES ON THE STRENGTH, LIFE, AND PERFORMANCE CHARACTERISTICS OF THE COMPOSITE STRUCTURE?

**Page intentionally left blank**

RECOMMENDATIONS FOR AN INTEGRATED POWER/ATTITUDE  
CONTROL SYSTEM (IPACS) TECHNOLOGY PROGRAM

W. W. Anderson  
NASA Langley Research Center  
Hampton, Virginia



## BOTTOM LINE

RECOMMEND AN R & D PROGRAM TO OAST

REQUIRES AN IMPLEMENTATION SCENARIO BE ASSUMED FOR SPACE STATION. THIS SCENARIO WOULD BE TESTED BY CONDUCTING APPROPRIATE TRADE STUDIES.

FOR THE PURPOSES OF THIS WORKSHOP, I ASSUME THE FOLLOWING SCENARIO:

O THE FIRST SPACE STATION WOULD UTILIZE AN IPACS WITH MECHANICAL BEARINGS BUT WITH A COMPOSITE ROTOR. \* TECHNOLOGY READINESS DATE: 1987

O AN UPDATED IPACS UNIT USING MAGNETIC BEARINGS WOULD REPLACE THE ABOVE UNITS AT AN APPROPRIATE POINT.

\* USE DOE AS CONSULTANTS. USE THEIR CONTRACTORS INITIALLY

## TECHNOLOGY ISSUES

### 1ST UNIT (MECHANICAL BEARINGS)

- O WHEEL CONFIGURATION - ENERGY DRIVEN?
- O WHEEL MATERIAL - GRAPHITE/EXPOXY?
- O BEARINGS - LUBRICATION (SKYLAB EXPERIENCE)?
  - REPLACEMENT ON ORBIT?
  - ON LINE BALANCING?
- O ELECTRONICS - IN/OUT EFFICIENCY? - NEW SOLID STATE DEVICE DESIGNS
- O GIMBAL CONFIGURATION - NO GIMBALS
  - SINGLE GIMBALS
  - DOUBLE GIMBALS

### 2ND UNIT (MAGNETIC BEARINGS)

- O ALL AXES ACTIVE - NEED STIFFNESS & LOAD CAPACITY
- O BACKUP BEARINGS - SAFETY?
  - HIGH LOAD
- O LONG TERM DEVELOPMENT REQUIRED?
- O MAGNETIC BEARINGS MAY ALLOW OR REQUIRE A NEW WHEEL CONFIGURATION (LARC, GSFC)

## SYSTEM INTEGRATION ISSUES

GIVEN:

- o MODERATE POINTING ACCURACY
- o DOUBLE-GIMBAL IPACS CONFIGURATION
- INTERACTION/ INTEGRATION ISSUES MINIMAL

ATTITUDE CONTROL OWNS GIMBALS

POWER OWNS SPIN ASSEMBLY

ACS MUST LIMIT PRECESSION RATIO  
MUST HAVE KNOWLEDGE OF WHEEL SPEEDS

POWER MUST STAY WITHIN WHEEL SPEED MINIMUMS

## RECOMMENDED PROGRAM

- o WORKSHOP/S
- o SPACE STATION TRADE-OFFS
- o HARDWARE DEVELOPMENTS
  - o NEAR-TERM UNIT READY 1987
  - o LONG-TERM UNIT READY 1992
- o SYSTEM STUDIES/SIMULATIONS/INCLUDING HARDWARE

## RECOMMENDED ORGANIZATION

- o ENDORSE LEAD CENTER CONCEPT
- o RECOMMEND LARC

**Page intentionally left blank**

RECOMMENDATIONS FOR COMPOSITE FLYWHEEL DEVELOPMENT

F. M. Elam  
NASA Johnson Space Center  
Houston, Texas

RECOMMENDED COURSE OF ACTION FOR U.S. GOVERNMENT  
FOR COMPOSITE FLYWHEELS

1. CONTINUE ACTIVE STATUS OF OAKRIDGE NATIONAL LABORATORY FLYWHEEL TEST FACILITY AND CADRE AND LAWRENCE LIVERMORE NATIONAL LABORATORY FLYWHEEL ENGINEERING CADRE
2. CONTINUE THE COMPOSITE FLYWHEEL DEVELOPMENT PROGRAM STARTED BY DEPARTMENT OF ENERGY (DOE)
3. DESIGN, MANUFACTURE, AND TEST FLYWHEELS IN THE 5.0 KWH (USEFUL) (6.7 KWH TOTAL) RANGE
  - o SELECT ONE OR MORE OF THE MOST INNOVATIVE NEW DESIGNS
  - o TEST FOR 10-YEAR STEADY STATE STRESS AFTER 10-YEAR RPM CYCLES AND PRECESSION TORQUE CYCLES. TEST A GROUP OF FLYWHEELS AT SEVERAL LEVELS (100%, 110%, 120% RPM)
4. IMMEDIATELY BEGIN 10-YEAR LIFE CYCLE TESTS ON AVAILABLE COMPOSITE FLYWHEELS MADE FOR THE DOE PROGRAM. DO THIS BY CONTRACT WITH DOE AND OAKRIDGE
5. DESIGN, MANUFACTURE, AND TEST SYSTEMS IN THE 5.0 KWH (PER WHEEL) RANGE FOR EACH OF THE FOLLOWING CATEGORIES:
  - A. REACTION WHEEL TWINS
    - (1) ENERGY STORAGE ONLY
    - (2) MOMENTUM MANAGEMENT & CONTROL TORQUES ONLY
    - (3) COMBINED ENERGY STORAGE, MOMENTUM MANAGEMENT, AND CONTROL TORQUES
  - B. SINGLE GIMBAL CMG'S/IPACS
    - (1) MOMENTUM MANAGEMENT & CONTROL TORQUES ONLY
    - (2) COMBINED ENERGY STORAGE, MOMENTUM MANAGEMENT, AND CONTROL TORQUES

- C. DOUBLE GIMBAL CMG'S/IPACS
  - (1) MOMENTUM MANAGEMENT & CONTROL TORQUES ONLY
  - (2) COMBINED ENERGY STORAGE, MOMENTUM MANAGEMENT, AND CONTROL TORQUES
- D. REACTION WHEEL TWINS
  - o ESPECIALLY DESIGNED FOR SUPER HIGH ELECTRIC DISCHARGE RATE SUITABLE FOR LASER AND NUCLEAR FUSION PELLETS

6. DESIGN, MANUFACTURE, AND TEST COMPONENTS:

- A. RIMS OF COMPOSITE FLYWHEELS
- B. HUB & HUB-TO-RIM ATTACHMENTS (i.e., COMPLETE ROTOR AND HUB) -- SEVERAL ALTERNATIVE DESIGNS
- C. MOTOR GENERATORS
  - o HIGH EFFICIENCY
  - o ESPECIALLY DESIGNS WHERE NO SLIP RINGS ARE REQUIRED
  - o CRYOGENIC MOTOR GENERATORS
  - o COOL-RUNNING ROTORS
  - o COOLING TECHNIQUES FOR ROTORS IN VACUUM
- D. TORQUER MOTORS AND GEARS
- E. MAGNETIC BEARINGS
  - o ACTIVE SERVO IN RADIAL DIRECTION
  - o INCLUDE CYROGENIC BEARINGS
- F. BALL BEARINGS - FOR HIGH SPEED
  - o INCLUDE COMPOUND BEARINGS - FOR REDUCED RELATIVE VELOCITY
- G. HYBRID BEARINGS
  - o MAGNETIC BEARINGS FOR SMALL PRECESSION TORQUES
  - o BALL BEARINGS (TOUCHDOWN) - FOR LARGE CMG TORQUES
  - o SPIN-UP MOTORS - FOR THE BALL BEARINGS, TO AVOID GALLING
- H. SAFETY CONTAINMENTS
- I. SLIP RINGS, ROLL RINGS, AND TRANSFORMERS TO TRANSMIT ELECTRIC POWER ACROSS REVOLVING GIMBALS

7. THE ABOVE ITEMS SHOULD NOT BE DONE SEQUENTIALLY, BUT IN PARALLEL :
  - o MUCH OF THE TECHNOLOGY REQUIRED HAS ALREADY BEEN DEVELOPED TO AN ADVANCED STAGE, SO NO PHASE NEEDS AWAIT ANOTHER PHASE
  - o MUCH TIME HAS BEEN LOST ALREADY
  - o URGENT NEED FOR COMPOSITE FLYWHEEL TECHNOLOGY EXISTS IN SEVERAL APPLICATIONS:
    - o SPACE
    - o MILITARY
    - o NUCLEAR
    - o CIVILIAN
  
8. PRIVATE INDUSTRY CANNOT AFFORD THE R&D COST BECAUSE THERE IS NO MASS MARKET.

PANEL DISCUSSION

F. E. Ford  
NASA Goddard Space Flight Center  
Greenbelt, Maryland



## INTRODUCTION

In order to assess the potential of electromechanical storage as a replacement for nickel-cadmium (Ni-Cd) batteries, one should understand the current capability of aerospace Ni-Cd batteries. The chart illustrates the maximum design depth of discharge currently being used in sizing Ni-Cd batteries for most Goddard missions. The three curves are "not to exceed" values for conditions stated. Life in excess of 8 years (44,000 cycles) in near-Earth orbit has been demonstrated on the OAO-C spacecraft with the batteries operating at 15 to 18 percent depth of discharge. An end-of-life test showed the capacity to be approximately 9 amp hours (out of 20 amp hours rated capacity) to 1.03 V per cell.

### MAXIMUM DESIGN UTILIZATION OF NICKEL-CADMIUM BATTERIES FOR SPACECRAFT APPLICATIONS (DEMONSTRATED CAPABILITY)

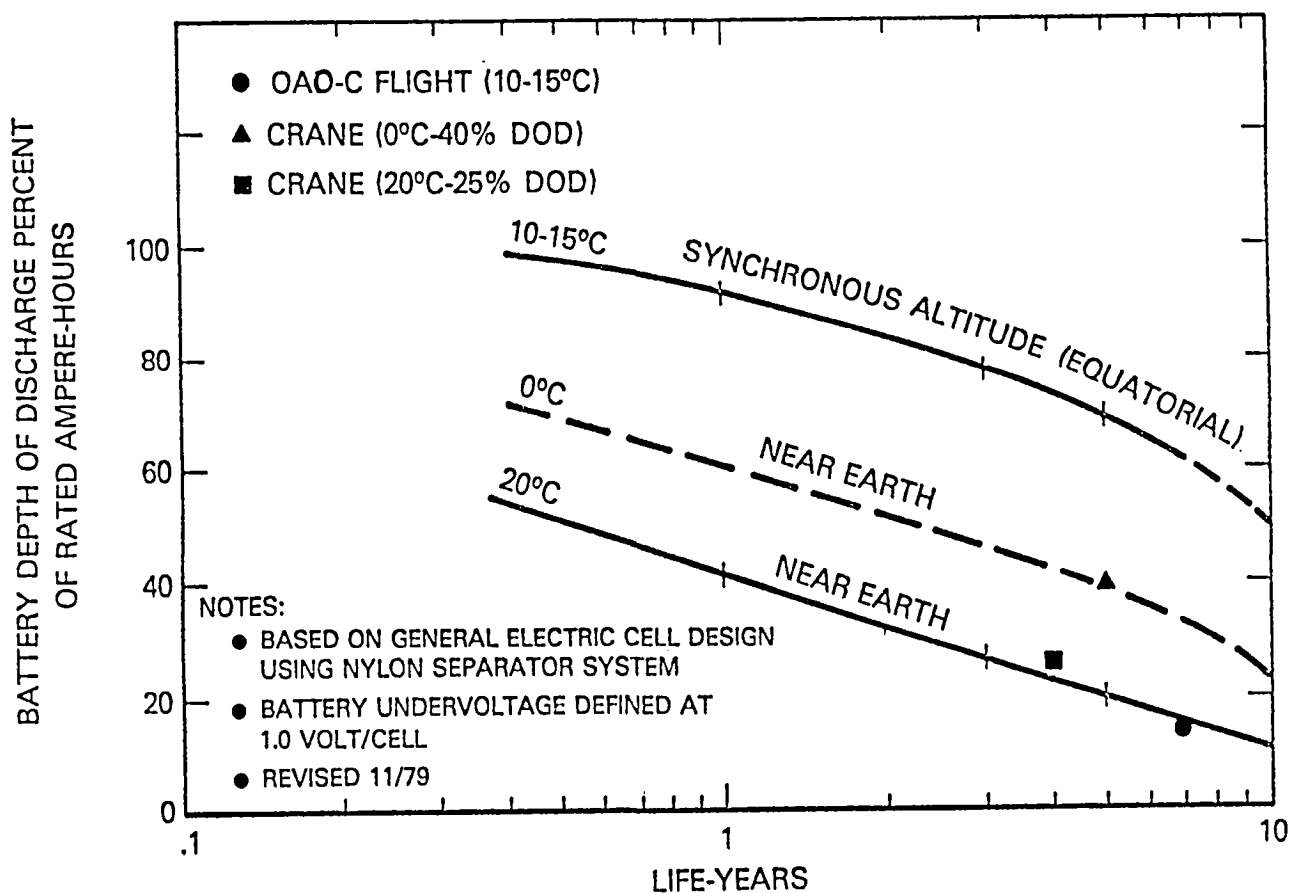

## CRITICAL TECHNOLOGY - COMPOSITE MATERIALS

The potential of inertial energy storage as a viable alternative option to electrochemical systems depends mainly on two critical technology areas: composite materials and magnetic suspension of a large rotating mass.

Data presented by Dr. Olszewski (ref. 1) indicated that the gain in Wh/kg of metallic wheels seemed to be one of diminishing return as compared with the potential for wheels or rims of composite materials. The fact that composite wheel performance is already exceeding what can be expected for metallic wheels is a strong argument for investing the R&D dollars in composite technology. This, along with evidence that indicates wheels of composite materials can be designed for "soft" failures (thus reducing the safety hazard and containment weight), are strong reasons for choosing composite material as a critical technology issue.

### COMPOSITE MATERIALS THAT WITHSTAND HIGH-SPEED CYCLIC STRESS

- o METALLIC WHEELS HAVE DIMINISHING PAYOFFS
- o LONG-TERM GROWTH IN WH/KG GREATER
- o FAILURE MODES LESS LIKELY TO BE SAFETY HAZARD

## CRITICAL TECHNOLOGY - MAGNETIC SUSPENSION

The second critical technology is one of demonstrating magnetic suspension of a large rotating mass. The principle of magnetically suspending a rotating body has been proven. A demonstration rim has been in existence at Goddard for approximately 10 years. The challenge is to increase the rim velocity from 33 m/sec to around 330 m/sec, which is the velocity required to achieve the projected energy storage capability. Another element of this technology is the design of the system to withstand large disturbances without extracting large amounts of energy or causing damage to the elements. This, along with the dynamic control over a wide range of environmental inputs, should be demonstrated on a large integrated system.

### MAGNETIC SUSPENSION OF LARGE ROTATING MASS

- o PRINCIPLE HAS BEEN PROVEN
- o ORDER-OF-MAGNITUDE INCREASE IN M/SEC
- o ABILITY TO WITHSTAND LARGE DISTURBANCES
- o DYNAMIC CONTROL STABILITY

## SYSTEM INTEGRATION - PROOF OF CONCEPT

There are three elements of system integration for an integral energy storage and attitude control system. The first element is proof of concept, in which the basic modes of operation are demonstrated. This includes the fundamental operation as a motor and generator with the electronics required for high-power and high-frequency commutation. The next logical step is to integrate the attitude control functions to determine the compatibility of the system requirements. It is expected that the speed of the control loops along with the energy management requirements would necessitate a digital system. The use of a microprocessor would provide a system that is highly independent of ground or crew operations (i.e., autonomous control of attitude and energy).

### PROOF OF CONCEPT FOR INTEGRATED POWER & CONTROL

#### MOTOR/GENERATOR MODES/FUNCTIONS

- o ATTITUDE CONTROL
- o BUS REGULATION
- o HIGH-POWER/HIGH-FREQUENCY COMMUTATION
- o CONTROL AND POWER SYSTEM COMPATIBILITY
- o CONTROL TECHNIQUES - ANALOG VS. DIGITAL
- o MODULARITY - SCALE-UP LIMITATION

## SYSTEM INTEGRATION - SYSTEM DEFINITION

The second element of system integration is actually an extension of the previous element in that a more detailed definition of the system configuration is obtained. It is important at an early stage to fully understand the safety issues, loop gains, and margins required to assure system stability and to define the requirements for detection and sensors needed for reliable operation. A fallout of this would be the system algorithms required in the microprocessor for performing the control and energy management functions.

### IDENTIFY SYSTEMS CONTROL & SAFETY FUNCTIONS

VIBRATION SHUTDOWN

INTERACTION OF POWER & CONTROL FUNCTIONS

CLOSED-LOOP OPERATION

DETECTORS AND SENSORS

SYSTEM ALGORITHM - CONTROL & ENERGY MANAGEMENT

## SYSTEM INTEGRATION - COMPONENT REFINEMENT

The third element of system integration is one of refining and "fine tuning" the components as an integrated system. By this point in the program, there are no technology issues. This effort is one of characterization of the system in terms of mechanical and electrical responses and also power bus characteristics, such as impedance, transient response, ripple, noise, and system efficiency. This all-up system test would generate the data base for a system model, identify salient parameters for a system performance specification (including interface requirements), and establish the boundary conditions for "safe" operations. Equally important is the task of defining the requirements for monitoring the health and welfare (telemetry requirements) for safe operations. At this point, a complete System Failure Mode and Effect Analysis should be completed.

## SYSTEM PERFORMANCE PARAMETERS

- o EFFICIENCY UNDER VARYING POWER & CONTROL PROFILES
- o DYNAMIC RESPONSE - ELECTRICAL & MECHANICAL
- o BUS CHARACTERISTICS - MOTOR VS. GENERATOR MODE
- o DATA BASE FOR SYSTEM MODELING
- o COMPATIBILITY IN HYBRID SYSTEM
- o SIGNALS FOR MONITORING "HEALTH & WELFARE" OF SYSTEM
- o FAILURE MODES AND SYSTEM SAFETY

## MECHANICAL ENERGY STORAGE SYSTEM ASSESSMENT

In examining the virtues of a mechanical energy storage system, it is necessary to look also at existing methods of accomplishing the same task. The chart illustrates what are believed to be some inherent limitations of electrochemical storage systems. It is a well-established fact that batteries are highly sensitive to operational parameters, previous history, aging effects, and the inexact science of manufacturing batteries for space applications. A comparison of total energy density of Ni-Cd batteries flown on two satellites (OAO-C and SMM) over a decade apart shows less than 0.5 Wh/kg difference. A reasonable conclusion from this is that there has been little, if any, improvement in the energy storage of Ni-Cd batteries over the past 15 years. This is not to say we are not smarter users. There have been improvements in the allowable usable energy density (depth of discharge) which have come about due to a quantum improvement in understanding how to manufacture reliable batteries as well as understanding the design and operation methods that enhance performance and life.

A very important aspect of the assessment process for future improvements is what appears to be the unwritten law governing life versus usable energy density. This law seems to indicate that the greater the energy storage content of an electrochemical system, the less cycle life you can expect to get. This raises serious questions as to the validity of pursuing any development program in electrochemical systems in an environment where life in terms of 10 years or in excess of 50,000 cycles is needed. Other factors that penalize a battery-based system are the thermal constraints ( $\pm 10^{\circ}\text{C}$  for Ni-Cd) and system complexity (individual cell protection and reconditioning) required to overcome known battery degradations. It should be noted that, to date, all space power systems have typically been designed for bus voltages in the 20- to 35-V range, thus requiring low-voltage batteries (15 to 25 cells in series). The reliability of high-voltage batteries, compatible with bus voltages in the 150- to 250-V range, has yet to be demonstrated.

### INHERENT LIMITATIONS OF ELECTROCHEMICAL SYSTEMS

- o DEGRADATION MODES HIGHLY SENSITIVE TO
  - A. OPERATIONAL PARAMETERS
  - B. PREVIOUS HISTORY/AGE
  - C. MANUFACTURING VARIABLES
- o FINITE LIMITATION OF ENERGY DENSITY IMPROVEMENTS
- o UNWRITTEN LAWS GOVERNING LIFE VS. USABLE Wh/Kg
- o USUALLY IMPOSED PENALTY ON THERMAL DESIGN ( $10\pm 10^{\circ}\text{C}$ )
- o RELIABILITY OF HIGH-VOLTAGE SYSTEMS NOT DEMONSTRATED
- o SYSTEM COMPLEXITY REQUIRED TO ACCOMMODATE LIMITATIONS

## PROGRAM JUSTIFICATION

The justification for an integrated power system and energy storage program lies principally in the potential offered in performance (Wh/kg) and life (>10 years). At present, there is no other system being proposed that can even approach a 10- to 20-year lifetime. A recent Goddard study (ref. 2) showed that a 3-kW module using existing technology is competitive with Ni-H<sub>2</sub> batteries. One very important benefit the flywheel motor/generator concept offers is the compatibility with the high-voltage system. The simplicity of a two-terminal device when compared with 100 or more series cells per battery is not a small item in terms of reliability. These basic benefits, along with other less tangible items, such as greater latitude in thermal control, ease with which "power modules" can be combined to form a high-power system, and the significant reduction in maintenance and service cost for a large space-based system, all point to a need to bring the technology to a point of "readiness" for space use.

### INTEGRATED POWER AND ATTITUDE CONTROL SYSTEM

- o LIFE - IN EXCESS OF 10 YEARS ESTIMATED
- o WH/KG - OFFER SUBSTANTIAL IMPROVEMENT OVER ELECTROCHEMICAL TECHNOLOGY
- o IDEAL FOR HIGH-POWER AND HIGH-VOLTAGE SYSTEM - 2 TERMINAL DEVICE
- o IMPOSES LESS DESIGN CONSTRAINTS ON OTHER SUBSYSTEMS (-25 TO +50°C)
- o SUITED FOR MODULAR APPROACH TO POWER SYSTEM DESIGNS - 2 TO 10 KW MODULES



## PROGRAM DEFINITION - SYSTEM DEMONSTRATION

The required program can be defined in three general technical areas. These are: demonstrate a working power system in the 2- to 5-kW range using inertial energy storage, integrate the control and power system function into the test bed, and, in parallel, perform system engineering studies to resolve a number of system questions.

The first element of program definition should be to establish a baseline power system breadboard for evaluating the performance of at least three wheel designs that are based on state-of-the-art DOE technology. This is required to obtain performance data on wheels that are designed specifically for space applications where cost is not a significant criterion in optimizing the design. It was stated by one attendee that the technical community has reached a point of diminishing return in analyzing data from the existing data base. Consequently, a primary objective of the test program would be to establish performance parameters of state-of-the-art designs. The second objective is the proof of concept with an operating system. It is important to note that the test need not be done on an optimized system in terms of Wh/kg.

### DEMONSTRATE A WORKING POWER SYSTEM IN 2- TO 5-KW RANGE USING INERTIAL ENERGY STORAGE

- o BASELINE USING EXISTING DOE WHEEL TECHNOLOGY AND MAGNETIC BEARINGS
- o IDENTIFY LIMITING TECHNOLOGY OF STATE-OF-THE ART WHEELS--NEW DATA BASE NEEDED
- o VERIFY POWER SYSTEM PERFORMANCE PARAMETERS WITH AN OPERATING SYSTEM
- o ESTABLISH SCALE-UP DESIGN CRITERIA--10-TO 20-KW RANGE
- o ESTABLISH SYSTEM SAFETY REQUIREMENTS

## PROGRAM DEFINITION - SYSTEM INTEGRATION

Once the concept has been demonstrated, the control functions need to be integrated into the system test. The algorithm required for both control and power would be used in an all-up demonstration system. Again, this does not have to be an optimized system. It is from this effort that a comprehensive understanding of system interaction can be understood. An objective of this work would be to develop power and control system operational characteristics and the engineering data base necessary to develop detailed design criteria for a flight system.

### INTEGRATE CONTROL AND POWER SYSTEM FUNCTIONS

- o DEVELOP ALGORITHMS FOR POWER AND CONTROL FUNCTIONS
- o DEMONSTRATE COMBINED OPERATION OF INTEGRATED SYSTEM
- o DEVELOP OPERATIONAL CONSTRAINTS AND/OR CRITERIA
- o DEVELOP SYSTEM PERFORMANCE SPECIFICATIONS

## PROGRAM DEFINITION - SYSTEM ENGINEERING STUDIES

The third aspect of the program definition is one of system engineering. The system engineering should be performed in parallel with the two previous tasks. In fact, this process is continuous and requires several iterations to resolve system engineering questions. It is obvious that there are two different technical approaches: Control Moment Gyros (CMG) or Reaction Wheels (RW) for the integrated system. Arguments of equal vigor were made for both. The fact that CMG's use gimbals, which requires transferring power across slip rings, automatically raises questions of reliability and longevity. The preferred approach appears to be RW; however, some reservation was expressed as to the adequacy of torque for control purposes. The other issues, such as redundancy, degree, and type of modularity, system safety, and automation, should be analyzed from the system viewpoint and not left to the component or subsystem specialist. There are a number of system interfaces that require a detailed analysis prior to arriving at a final configuration. One particular problem area is the physical location of several modules on a large spacecraft structure and the associated alignment requirements. The basic task is one of doing a comprehensive system engineering evaluation in order to resolve key technical issues prior to finalizing the configuration of the integrated power and attitude control system.

### SYSTEM ENGINEERING

#### SYSTEMS ISSUES

##### CMG VERSUS REACTION WHEELS

- SYSTEM SIZE - CONTROL VERSUS ENERGY STORAGE NEEDS
  - MODULARITY
- REDUNDANCY - POWER VERSUS CONTROL REQUIREMENTS
  - HYBRID DESIGN
- SYSTEM SAFETY - REQUIREMENTS FOR MAN-RATING
- AUTOMATION - DEPENDENCY OF SPACECRAFT COMPUTER

##### SYSTEM INTERFACE

- MECHANICAL - DISTRIBUTED VERSUS CENTRALIZED
- THERMAL - HEAT REJECTION AND THERMAL CONTROL
- ELECTRICAL - DISTRIBUTION, GROUNDING, RFI, EMI
- COMMAND & TELEMETRY - DATA REQUIREMENTS

##### SYSTEM VERIFICATION

- o ESTABLISH SYSTEM LEVEL PERFORMANCE PARAMETERS
- o QUALIFICATION AND ACCEPTANCE CRITERIA
  - THERMAL & MECHANICAL
  - ALIGNMENT OF MODULES
  - ELECTRICAL

## REFERENCES

1. Olszewski, Mitchell: Overview of State-of-the-Art Flywheel Technology. Integrated Flywheel Technology - 1983, NASA CP-2290, 1983, pp. 35-46.
2. Rodriguez, G. E.; Studer, P. A.; and Baer, David A.: Assessment of Flywheel Energy Storage for Spacecraft Systems. NASA TM-8506, May 1983.

**Page intentionally left blank**

IPACS WORKSHOP COMMENTS

J. L. Miller  
NASA Marshall Space Flight Center  
Huntsville, Alabama

## IPACS WORKSHOP COMMENTS

- 0 THERE IS APPARENTLY NOT A GOOD DATA BASE TO SUPPORT IPACS PERFORMANCE TRADE NUMBERS; HOWEVER, THE DATA THAT DOES EXIST ARE SUFFICIENT TO JUSTIFY SOME LEVEL OF THRUST ON IPACS TECHNOLOGY
  - PIN DOWN WHEEL MATERIAL DEGRADATION RATE
    - CREEP
    - FATIGUE
  - ESTABLISH LIFE EXPECTANCY OF MECHANICAL BEARING FOR SPEED AND DIAMETER OF INTEREST
  - PERFORM OPTIMUM DESIGN OF MOTOR/GENERATOR AND POWER ELECTRONICS
- 0 ABOVE IS REQUIRED BEFORE A CREDIBLE TRADE STUDY CAN BE COMPLETED COMPARING ENERGY STORAGE APPROACHES
- 0 THERE SEEMS TO BE SUFFICIENT NEED AND FEASIBILITY DATA FOR MAGNETIC BEARING TO JUSTIFY SOME LEVEL OF TECHNOLOGY PROGRAM IN THIS AREA--REGARDLESS OF WHETHER ENERGY STORAGE AND ATTITUDE CONTROL DISCIPLINE PROBLEMS ARE SIMULTANEOUSLY SOLVED. (BOTH DISCIPLINES WILL BENEFIT FROM ANY TECHNOLOGY CONTRIBUTION)
- 0 THERE APPEARS TO BE A NEED FOR A MATERIALS TECHNOLOGY EFFORT UNIQUELY DIRECTED AT MOMENTUM WHEEL APPLICATION
- 0 IPACS CONTROL LAW TECHNOLOGY NEEDS TO BE DEVELOPED CONCURRENT WITH HARDWARE
  - VERIFICATION IS NEEDED IN HYBRID TEST BED
- 0 IPACS APPLICABILITY TO kW AS WELL AS MULTI-100 kW SYSTEMS NEEDS TO BE ESTABLISHED
  - DETERMINE APPROPRIATE MODULE SIZES
- 0 THERE IS A NEED TO FOLLOW UP THIS WORKSHOP WITH AN INDUSTRY PARTICIPATION WORKSHOP ON TECHNOLOGY PLUS SYSTEM APPLICATION ISSUES RELATIVE TO IPACS
  - NEEDS TO FOLLOW ASAP AFTER HQ DECISION TO PROCEED WITH SOME TYPE OF IPACS TECHNOLOGY THRUST
  - INTEGRATION OF THE ENERGY STORAGE FUNCTION AND THE ATTITUDE CONTROL FUNCTION SHOULD BE THOROUGHLY ADDRESSED
  - MSFC OFFERS TO HOST THIS WORKSHOP AND INCLUDE TOUR/INSPECTION OF TEST BED RELATED ACTIVITIES

## APPENDIX - SYMBOLS AND ABBREVIATIONS

A.C.	alternating current
A/C	attitude control
ACAPS	Advanced Control and Power System
AMCD	Annular Momentum Control Device
ATM	Apollo telescope mount
CDG	concept development group
CG	center of gravity
CHR	charger
CM	center of mass
CMG	control moment gyro
CNTRLR	controller
CP	center of pressure
D&D	design and development
D.C.	direct current
DET	direct energy transfer
DGCMG	double-gimbal control moment gyro
DISTR	distribution
DOD	Department of Defense
DOE	Department of Energy
$E_B$	back EMF voltage
ECLS	environmental control/life support
EMF	electromotive force
FC; F/C	fuel cell
FH	flight hardware
FW	flywheel
GG	gravity gradient
GN&C	guidance, navigation, and control
H	angular momentum
$\dot{H}$	change in momentum
H/M	momentum-to-mass ratio
I	mass moment of inertia
$I_x, I_y, I_z$	moments of inertia about x, y, and z
IC	internal combustion
ID	inside diameter



I.D.	identification number
IGA	inner gimbal assembly
IPACS	Integrated Power/Attitude Control System
K.E.	kinetic energy
LV	local vertical
LVLH	local vertical, local horizontal
M/G	motor-generator
MMS	multimission modular spacecraft
MSS	modular space station
OAST	Office of Aeronautics and Space Technology
OSTS	Office of Space Transportation Systems
PFET	power field effective transistor
PK	peak
PM	permanent magnet
PM&D	program management and development
POC	proof of concept
P.O.P.	perpendicular to orbit plane
PSH	power solar array
PSS	power space station
PWM	pulse width modulator
PWR	power
R	reference (subscript) for body axis
$R_o$	outer radius
R&T	research and technology
RAM	research and application module
RCS	reaction control system
RFC	regenerative fuel cell
RS	time on Sun side
S/A	solar array
SAB	solar-array battery
SGCMG	single-gimbal control moment gyro
SOA	state of the art
SOC	state of change
SS	Space Station
$T_D$	orbital disturbances
$T_E$	experiment-generated disturbances

$T_T$	torque
TBD	to be determined
TCS	thermal control system
TD	time on dark side
TDRS	Tracking and Data Relay Satellite
$Y_{CM}$	center of mass on y axis
$\beta$	Sun angle
$\eta_B$	efficiency of bus
$\eta_{BPT}$	efficiency of bulk power transfer device
$\eta_{FC}$	efficiency of regenerative fuel cell (RFC)
$\eta_{PC}$	efficiency of power conversion
$\eta_{PCT}$	efficiency of power conditioning/transformation
$\eta_{SA}$	efficiency of solar array
$\eta_{SU}$	efficiency of switching unit
$\theta$	roll
$\phi$	pitch
$\psi$	yaw
$\omega_0$	rotation rate of solar arrays

1. Report No. NASA CP-2290		2. Government Accession No.		3. Recipient's Catalog No.	
4. Title and Subtitle INTEGRATED FLYWHEEL TECHNOLOGY - 1983				5. Report Date December 1983	
				6. Performing Organization Code 506-57-13-10	
7. Author(s) Claude R. Keckler, Guillermo E. Rodriguez, and Nelson J. Groom, Editors				8. Performing Organization Report No. L-15707	
				10. Work Unit No.	
9. Performing Organization Name and Address NASA Langley Research Center Hampton, VA 23665 and NASA Goddard Space Flight Center Greenbelt, MD 20771				11. Contract or Grant No.	
				13. Type of Report and Period Covered Conference Publication	
12. Sponsoring Agency Name and Address National Aeronautics and Space Administration Washington, DC 20546				14. Sponsoring Agency Code	
15. Supplementary Notes Claude R. Keckler: Workshop Cochairman, Langley Research Center. Guillermo E. Rodriguez: Workshop Cochairman, Goddard Space Flight Center. Nelson J. Groom: Langley Research Center.					
16. Abstract <p>A two-day workshop on integrated flywheel systems was held at the NASA Goddard Space Flight Center in Greenbelt, Maryland, August 2-3, 1983. The purposes of the workshop were to assess the state of the art in integrated flywheel systems technology, to determine the potential of such systems concepts, to identify critical technology areas needing development, and to scope and define an appropriate program for coordinated activity in this technology area. The first day consisted of a number of presentations by personnel representing NASA and the Department of Energy (DOE). These presentations provided an excellent overview of recent and current technology efforts as well as results of preliminary tradeoff and sizing analyses in the areas of power, control, and integrated systems. On the second day, a panel comprised of one member from each of the six represented NASA field installations addressed the issues of critical technology barriers, system integration, program justification, and program definitions. A summary of the workshop along with a discussion of the major recommendations and conclusions drawn by the participants is presented. In addition, a copy of each paper given at this meeting and the panelists' summaries are included.</p>					
17. Key Words (Suggested by Author(s)) Integrated flywheel systems Energy storage Attitude control Power subsystems			18. Distribution Statement  Unclassified - Unlimited  Subject Category 20		
19. Security Classif. (of this report) Unclassified		20. Security Classif. (of this page) Unclassified		21. No. of Pages 220	22. Price A10

National Aeronautics and  
Space Administration

Washington, D.C.  
20546

Official Business

Penalty for Private Use, \$300

SPECIAL FOURTH CLASS MAIL  
BOOK

Postage and Fees Paid  
National Aeronautics and  
Space Administration  
NASA-451



**NASA**

---

POSTMASTER: If Undeliverable (Section 158  
Postal Manual) Do Not Return

---

---