

LaNi₅ HYDRIDE CRYOGENIC REFRIGERATOR TEST RESULTS

Jack A. Jones

Jet Propulsion Laboratory/California Institute of Technology

ABSTRACT

A complete LaNi₅ hydrogen absorption cryogenic refrigerator system has been developed and life tested for 300 continuous hours at 29 K. The system uses low temperature waste heat of approximately 100°C (373 K) as a power source, and has no moving parts other than self-operating valves. The refrigerator's three alternately cycled compressors provide approximately 650 mW of cooling for a given average waste heat power of 250 watts. The total weight of LaNi₅ in all three compressors is 288 gms. The LaNi₅ compressor units operate by absorbing 16 standard liters each of hydrogen gas at room temperature and low pressure. When heated to 100°C (373 K), most of the hydrogen gas is liberated at 40 atmosphere pressure and is driven through a standard heat exchanger - Joule Thomson expansion valve cooling loop until cooled to liquid hydrogen saturation temperatures (20 K at 1 atmosphere or 29 K at 6 atmosphere pressure). The returning hydrogen is then absorbed back into the water-cooled LaNi₅ compressor units. The cycle continues automatically by means of an electronic sequencing timing mechanism which provides 3 minutes of heating and 3 minutes of cooling to each of the three compressors which are phased such that a constant supply of high pressure hydrogen gas is provided.

Although some contamination due to impure hydrogen was initially experienced, the first life test (June, 1983) exceeded 300 hours of continuous operation, and longer periods are expected in the future. Recent research has indicated that with a fully clean hydrogen system, hundreds of thousand cycles should be attainable, even though some degradation may eventually occur. Simple vacuum reactivation of the hydride can be performed if contamination effects are experienced. Due to the lack of moving parts, other than self-operating, long-life valves, the refrigerators predicted life is extremely long, and, in fact, should potentially attain at least 10 years of continuous operation.

INTRODUCTION

This paper describes the results of preliminary testing performed on the hydride compressor for the Molecular Absorption Cryogenic Cooler (MACC). As explained in References 1 and 2, the overall purpose of the MACC compressor

is to pump gaseous hydrogen at high pressure through a series of heat exchangers and a Joule-Thomson (J-T) valve such that the net cooling effect due to expansion of the gas at the J-T valve lowers the hydrogen temperature to its liquefaction point (20 K at one atmosphere pressure).

The basic theory of the compressor operation relies on the fact that the intermetallic compound LaNi_5 absorbs about six atoms of hydrogen per unit formula at an equilibrium pressure of a few atmospheres at room temperature. The density of the absorbed hydrogen at room temperature is almost twice the density of free liquid hydrogen at cryogenic temperatures. The equilibrium pressure of the absorbed hydrogen is a very strong function of temperature, and thus the hydrogen static pressure can be increased from 4 atmospheres at 40°C to about 60 atmospheres at 120°C (393 K).

The basic advantages of this type of system are that it provides considerably lower temperatures (as low as 20 K) than those from passive radiator systems (approximately 80 K), and yet it still has no mechanical moving parts, other than self-operating check valves (Figure 1). It is much simpler and has a much longer life expectancy than present orbiting mechanical refrigeration systems, and it can be operated using low temperature waste heat, e.g., RTG waste heat, or direct solar heat.

In the example shown in Figure 2, LaNi_5 sorption compressors are heated by a black plate facing the sun, and they are cooled by a room temperature space radiator. Switching between heating and cooling is provided by thermal gap switches which are alternately filled with a conductive gas for conduction, and then evacuated for non-conduction. A two phase lithium canister (not shown) on the black solar heating plate allows for solar heat retention while in the shady portion of a low earth orbit. The particular system shown is for cooling large liquid hydrogen refueling tanks for NASA's future Space Station, and includes a 120°K low earth orbit directional advanced radiator. The radiator, or some first stage refrigeration device, is necessary to insure an overall good coefficient of performance. Because hydride refrigeration can use heat from lightweight solar heating plates or waste heat from radioisotope thermal generators (RTGs) instead of electricity from heavier solar electric power systems, the overall spacecraft system weight is significantly lighter than for any other 20°K refrigeration system (Reference 3).

HARDWARE

An overview photograph of the tri-compressor refrigerator test breadboard system is shown in Figure 3 and schematically in Figure 4. The control panel is visible in the far right position of Figure 3 and is

adjacent to the three compressors. The Joule-Thomson/heat exchanger assembly is contained in the one gallon silvered dewar, while the rest of the lines on the board are plumbing interfaces. Each of these portions of hardware is described in detail below.

COMPRESSORS

A sketch of a single hydride compressor appears in Figure 5. The primary consideration in the design of this compressor is to add and remove heat as quickly as possible in order to produce the highest possible hydrogen flow rate for a given mass of hydride. A MINCO resistance heater is bonded to the outside of the 5/8" stainless steel tube. Using the heater manufacturer's suggested bonding method (RTV) resulted in a detached heater after a number of cycles, possibly due to high thermal shock stresses. Application of Epoxy 2850/11 with catalyst #11, however, has proven much more successful after repeated thermal cycling.

The heat is transferred into the low-conductivity powder by means of a close fitting cylinder of high purity copper foam that is placed inside the tube. During the cooling cycle, the heater power is turned off, and water is pumped through the annulus between the water housing and the compressor tube. In order to keep the very fine LaNi_5 powder from leaving the compressor tube and contaminating the system plumbing, a fine porous sintered stainless steel filter (2 micron nominal pore size) is inserted inside the compressor. The potential problem of long term filter clogging does not occur, as the hydrogen flows both ways through the filter.

PLUMBING

As shown in Figure 4, the plumbing interface consists of all lines, and valves as well as the holding tank, and hydrogen reservoirs. As the high pressure hydrogen leaves any of the heated compressors, it is directed to a common line by means of the indicated check valves. This high pressure hydrogen is then stored in a "holding tank" which is attached to the Joule-Thomson (J-T) cryostat assembly. Thus, the J-T assembly is supplied with a continuous flow of high pressure hydrogen. The pressure-activated solenoid valve is set at a very high pressure (850 psi) and is used as a safety in case the J-T valve fails.

After the hydrogen passes through the J-T assembly (described in next section), it is at a low pressure (typically about 6 atmospheres for this operation) and is then absorbed by a cooled compressor. The one gallon

reservoir is used to even out any small pressure pulses due to the somewhat non-uniform, hydrogen flow.

It should be noted that the relatively large surface area of the plumbing system upstream of the J-T assembly allows the hydrogen gas to cool from about 110°C (383 K) to room temperature by simple natural convection cooling.

JOULE-THOMSON ASSEMBLY

A schematic of the Joule-Thomson cryostat assembly appears in Figure 6. Room-temperature hydrogen gas enters a two meter long 1/16" counterflow coiled heat exchanger and is lowered to about 80 K at the cold exit. The heat exchanger coils are surrounded by closed cell insulation to minimize parasitic heat leaks. The hydrogen is cooled to about 77 K when it passes through an additional one meter section of 1/16" heat exchanger loops that are submerged in the LN₂. It is necessary to insure that the hydrogen temperature is below its inversion temperature of 202 K in order for the J-T expansion to result in a net cooling.

For actual deep space operation, the 77K LN₂ bath heat exchanger submersion would be replaced by a cold space radiator below the hydrogen inversion temperature of 202°K. The lower the radiator temperature, the better the hydride refrigerator's coefficient of performance (References 1 and 3). As an alternative, a first stage refrigerator system could be used instead of the LN₂ bath. For sizing purposes, approximately one watt of heat must be removed by the first stage refrigerator, for every watt of heat removed at 20°K by the hydride refrigerator.

The heat exchanger coils then enter into a high vacuum container that is also submerged in the LN₂. An additional two meter counterflow heat exchanger length allows the GH₂ to cool to slightly above its boiling temperature. Expansion through the J-T valve, which is actually a modified adjustable flow-through check valve (Figure 7), drops the 40 atmosphere pressure to about 6 atmospheres and causes partial liquefaction of the hydrogen. A small chamber collects the LH₂, which can be boiled to provide constant temperature cooling at 29 K or lower if lower GH₂ pressures are used. The returning hydrogen gas then pre-cools the entering hydrogen gas.

CONTROL PANEL

The control panel (barely visible on the right side of the Figure 3 photograph) has an electrical timing mechanism that allows each compressor

to be heated for three minutes and cooled for three minutes. The compressors are phased such that they provide a nearly uniform flow of hydrogen gas through the system. At present, all switches and relays are high-lifetime mechanical types, although even longer life, lightweight solid state electrical devices would be used for spacecraft operation. For the breadboard design, a mechanical override system exists independent of each automatically timed operation, so that independent tests could be made and controlled for each compressor.

TEST RESULTS

HYDRIDE ACTIVATION

Before actually building a test set-up, it was necessary to "activate" the LaNi_5 so that it would absorb and desorb hydrogen in the proper manner. As received from the manufacturer, Ergenics, the LaNi_5 is in the form of 1/4 inch chunks and has little hydrogen absorbing properties. In order to be broken down into a fine powder so that large quantities of hydrogen can be absorbed, it was necessary to cycle the powder several times between high pressure hydrogen (200 psi) and a near vacuum, allowing at least two hours for each portion of the cycle.

Each compressor contains 96 grams of LaNi_5 and was found to absorb 16 liters of hydrogen gas. This translates to approximately 6 atoms of hydrogen being absorbed onto each molecule of LaNi_5 , as previously reported in the literature (Reference 2).

ISOTHERM DATA

In this portion of the testing it is desired to obtain the temperature-pressure relationships for various concentration levels of hydrogen in the powder. This information is necessary for further compressor performance sizing and for comparison to previous results (Reference 2). After the compressor had absorbed as much hydrogen as possible at the cooling water temperature of 21°C (294 K), its heater was activated at low power (37.5 watts) and the pressure regulator on the board (Figure 4) was set open, i.e., no hydrogen-gas was allowed to flow back to the reservoir. Core temperature versus line pressure measurements were then made for increasing core temperature readings. At 100°C (373 K), the estimated pressure was just over 40 atmospheres, while lower temperatures resulted in much lower pressures. Following this, about 4 standard liters of hydrogen-gas were allowed to flow back into the hydrogen reservoir and the hydrogen supply

valve (Figure 4) was closed. Similar T versus P measurements were made on the remaining gas in the compressor, which was then at a density of about 4.5 atoms of hydrogen per molecule of LaNi_5 .

Similar measurements were then made for other hydrogen concentrations and the results are plotted in Figure 8. The JPL data showed somewhat higher pressure readings for any given temperature and hydrogen concentration than those published by Van Mal et al (Reference 2). A partial explanation of this may be due to slight variations in the La/Ni ratio of the absorbent.

The indicated boxed cycle in Figure 8 is an actual typical operating cycle of the powder. The horizontal lower line represents a three minute cooldown, during which the hydrogen heat of absorption is removed. This is followed by a 40 second heating temperature rise during which no hydrogen gas is pumped. Next, a 100 second heating outgassing occurs during which the hydride temperature increases only slightly, while high pressure hydrogen gas is driven off the hydride powder. The left-side pressure-temperature drop corresponds to the short time when the hydrogen gas traverses the J-T-heat exchanger assembly.

OPEN CYCLE OPERATION

In the preliminary open-cycle operation tests, the hydrogen exhaust gas was allowed to exit the system to an outdoor vent. The system was rapidly prechilled to about 30 K by supplying a high flow of 40 atmosphere GH_2 to the J-T valve from a K-Bottle of supplied hydrogen. The K-Bottle source pressure was then reduced, and a slight temperature decrease was noted, presumably due to a lowering of the back pressure with corresponding reduced saturated vapor temperature. The pressure was continuously reduced until a slight temperature rise was noted. At this point, the parasitic heat loads became slightly larger than the available cooling load, and net heating resulted.

The minimum upstream supply pressure required to maintain 20 K was thus found to be approximately 9.5 atm absolute with a resulting flow rate of approximately 100 scc/sec. The corresponding calculated heat load is 150 mW, assuming a highly efficient heat exchanger. The net cooling load is calculated as the mass flow rate times the difference between the cold heat exchanger inlet and outlet enthalpies, as further explained in Reference 5.

CLOSED CYCLE OPERATION

After each of the compressors had been confirmed to achieve their expected performance, the entire system was operated in a closed cycle mode. The J-T assembly was precooled for two hours with a small GN_2 internal pressure to aid in its convective cooldown time from room temperature. A full internal vacuum (10^{-5} Torr) was then drawn inside the J-T chamber and the three compressor system was activated. The net average flow rate of hydrogen gas was measured to be approximately 100 scc/sec with a pressure drop from approximately 39 atmospheres to 6 atmospheres. The flow rate was measured by means of measuring the pressure rise in the one gallon reservoir (Figure 4) during separate heating cycles. The J-T temperature finally reached approximately 30 K in about an hour and remained below 30K for the following 300 hours. Although two of the check valve rubber seats failed (metal seats have since been installed), the compressors showed no measureable degradation even after 300 hours of continuous operation. With a predicted life of at least one million cycles at room temperature, the new metal seat check valves should last at least 10 years.

It should be mentioned that recent research by Cohen and Wernick (Reference 4) has indicated that for very clean systems, intrinsic degradation of the LaNi_5 powder below 100°C should not be significant unless hundreds of thousands of cycles are attained. Furthermore, the LaNi_5 powder is readily reactivated, even after severe contamination. Further research by Goodell (Reference 5) has shown that although 300 psi pressure cycling results in some measurable degradation after 1500 cycles, the exponential limit of degradation even after hundreds of thousands of cycles, appears to be only about 50%. Goodell has also found that other hydride compounds such as $\text{LaNi}_{4.7}\text{Al}_{0.3}$ apparently have no measurable degradation after thousands of cycles (Reference 5).

SUMMARY AND CONCLUSIONS

A LaNi_5 hydride absorption cryogenic refrigerator has been built, and preliminary testing to 20 K open cycle and 29 K closed cycle has been performed. The refrigerator compressors consist of three units which are cooled by water and heated by electrical resistance heaters. High purity copper foam inside the compressors enhances heat transfer into and out of the enclosed LaNi_5 powder. During cooldown to room temperature, six atoms of hydrogen are absorbed at low pressure onto each LaNi_5 molecule, and during heatup to 110°C , the hydrogen is driven off at 40 atmospheres pressure. The pressure isotherm data for the LaNi_5 /hydrogen system is similar to that previously obtained (Reference 2), although slightly higher, possibly due to a somewhat different La/Ni ratio.

During refrigerator operation, high pressure gas passes through a Joule-Thomson valve/heat exchanger assembly, and provides open cycle cooling, i.e., venting to ambient, to 20 K. Closed cycle cooling has provided a calculated 650 mW of cooling at 29 K for 6 atmosphere bottom cycle pressures. Contamination due to 50 ppm hydrogen gas impurities initially prevented long term operation (in excess of two hours per test period), but switching to UHP hydrogen, however, has allowed test periods in excess of 300 hours with no measurable degradation in compressor performance. If accidentally contaminated, the LaNi_5 powder is quickly reactivated by heating the powder while under high vacuum. The predicted lifetime for very clean hydride systems below 100°C (373 K) is hundreds of thousands of cycles (Reference 3), although some degradation may eventually occur (Reference 4). Use of $\text{LaNi}_{4.7}\text{Al}_{0.3}$ in place of LaNi_5 could potentially increase hydride life even further, since $\text{LaNi}_{4.7}\text{Al}_{0.3}$ has exhibited no measurable degradation even after thousands of cycles (Reference 4).

Due to the lack of moving parts, other than self-operating, long-life valves, the JPL refrigerator's predicted life (with clean hydrogen) is extremely long, and based on predicted check valve life, should potentially last at least 10 years.

QUESTION

J. Verdier, CEA/CENG, Grenoble, France

1. What is the amount of time that each compressor is on during cycling?

Authors response to J. Verdier

Each compressor is heated for three minutes and cooled for three minutes. The three compressor cycles are phased 120° relative to each other such that a continuous flow of high pressure hydrogen is supplied to the Joule-Thomson cooling assembly.

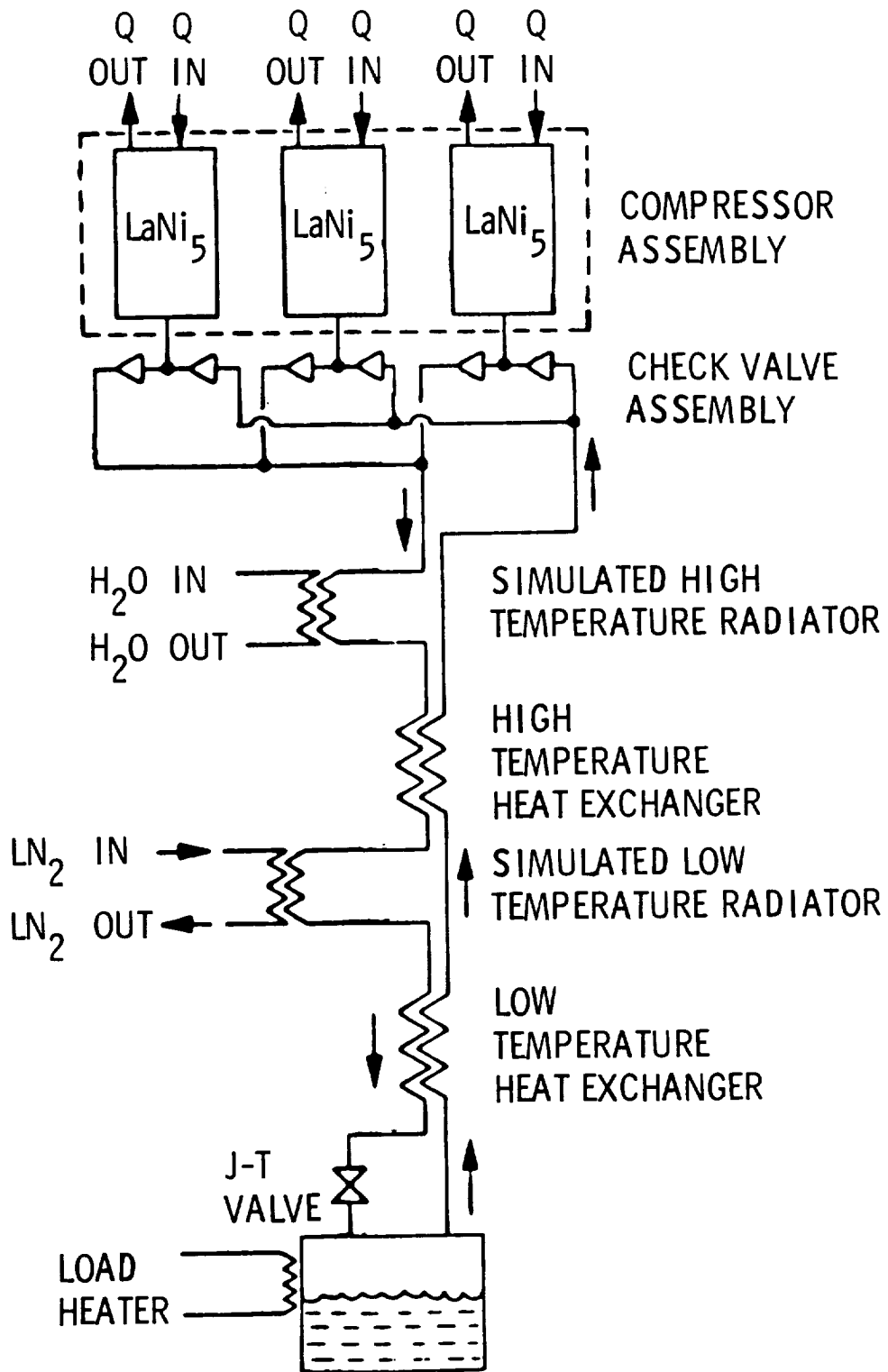

Figure 1. Hydride refrigerator operational schematic.

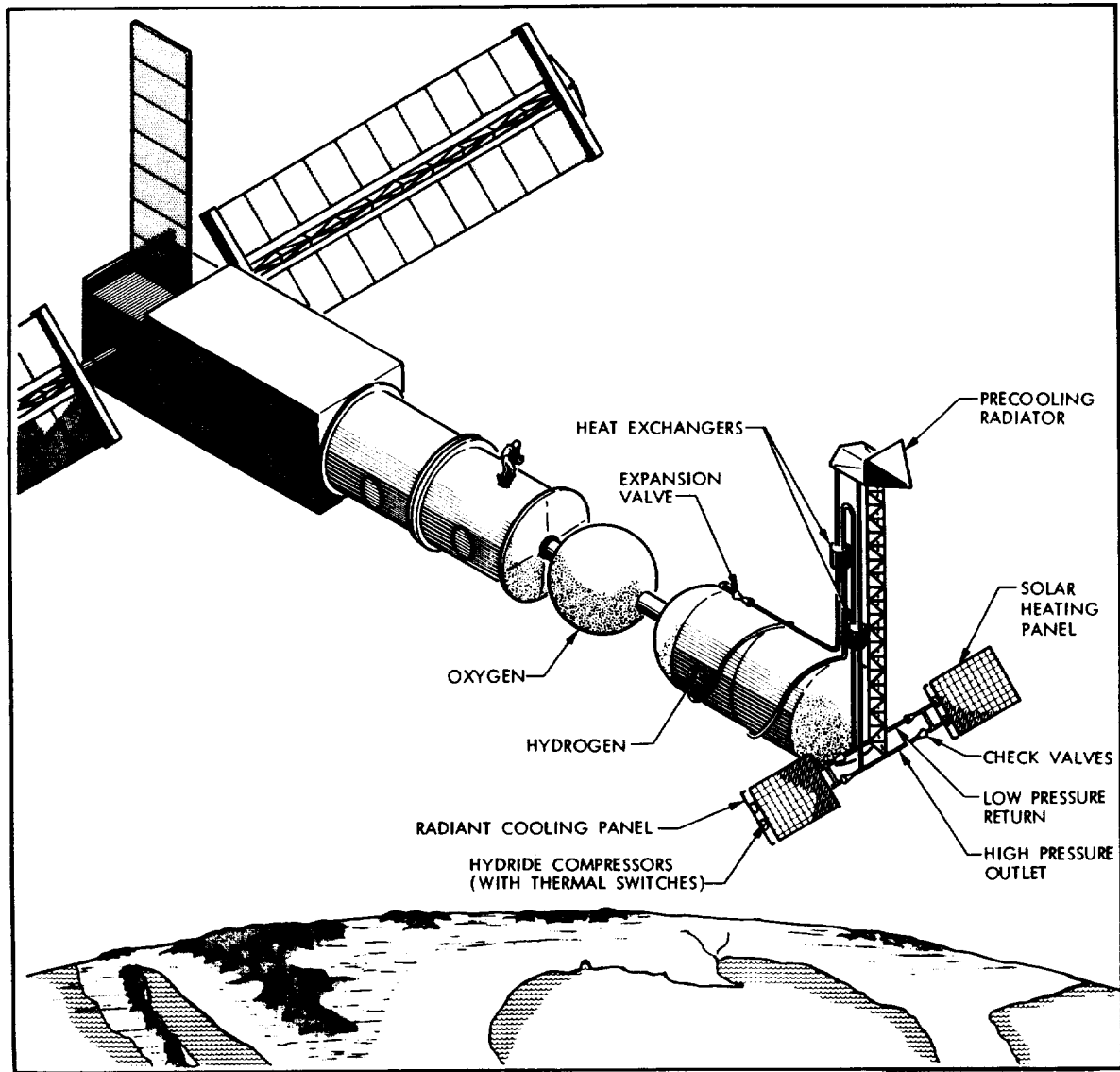

Figure 2. Space station refueling port with hydride refrigeration.

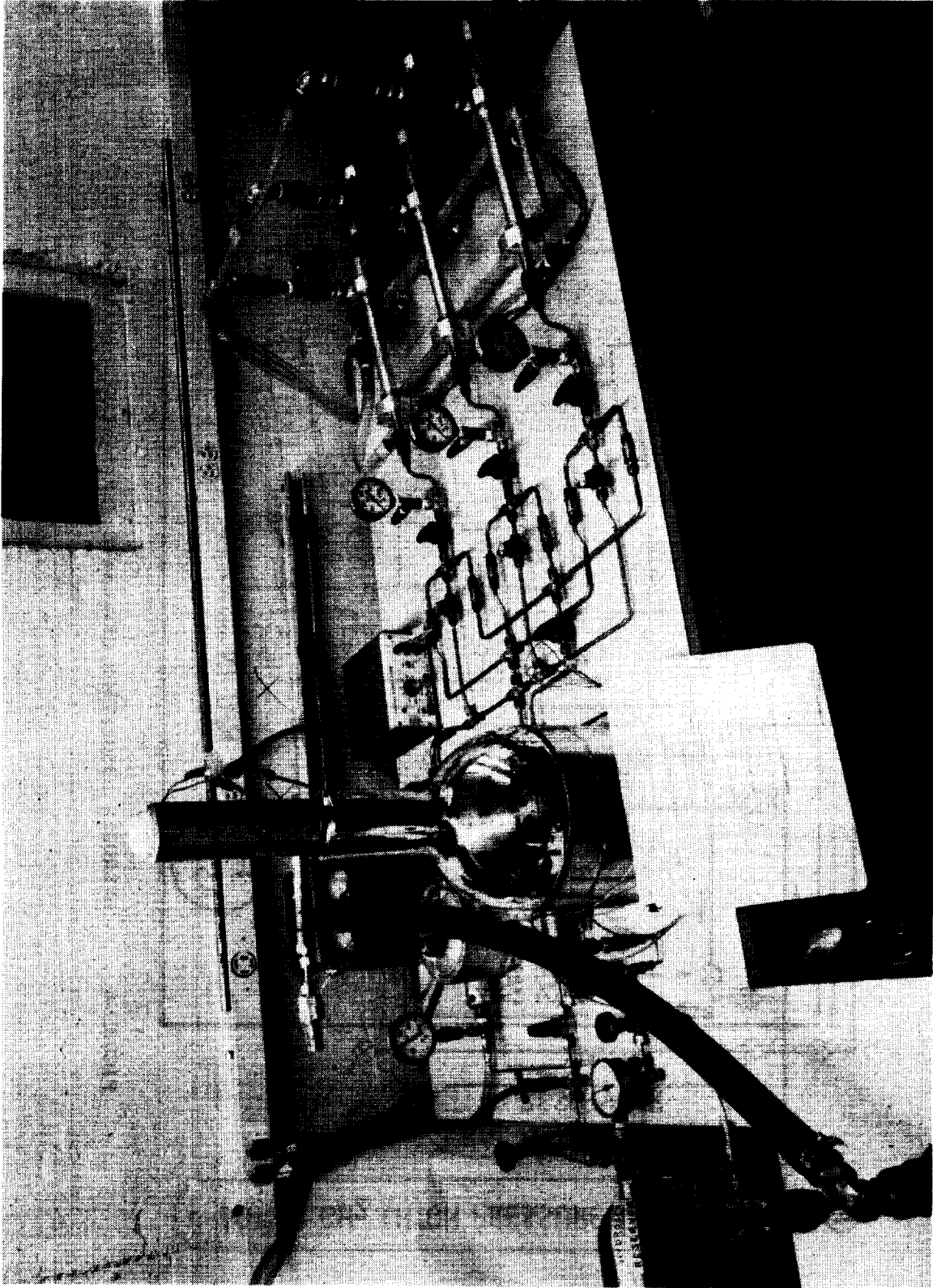

Figure 3. JPL Hydride Absorption Cryogenic Refrigerator.

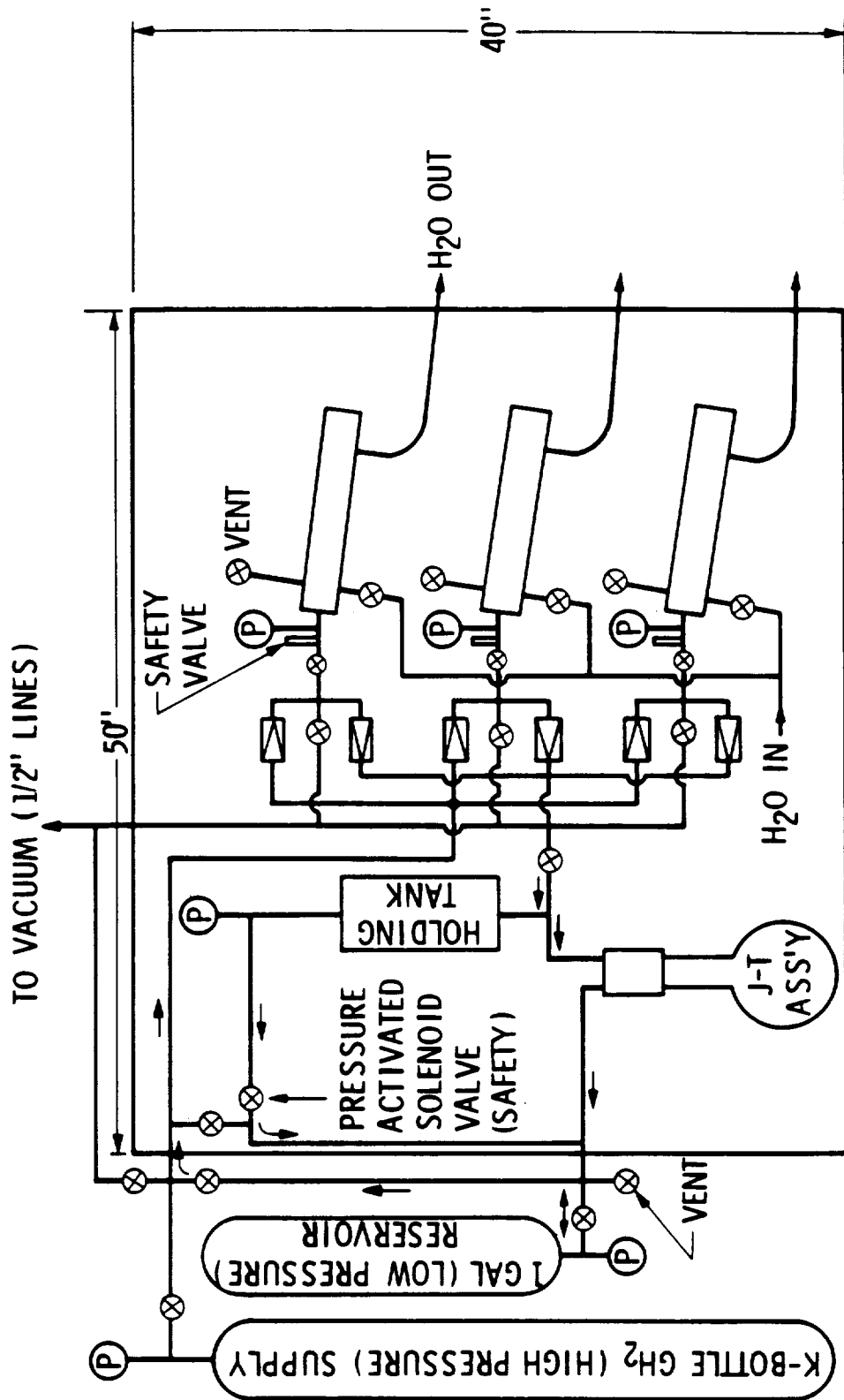

FIGURE 4 HYDROGEN ABSORPTION CRYOGENIC REFRIGERATOR-BOARD LAYOUT

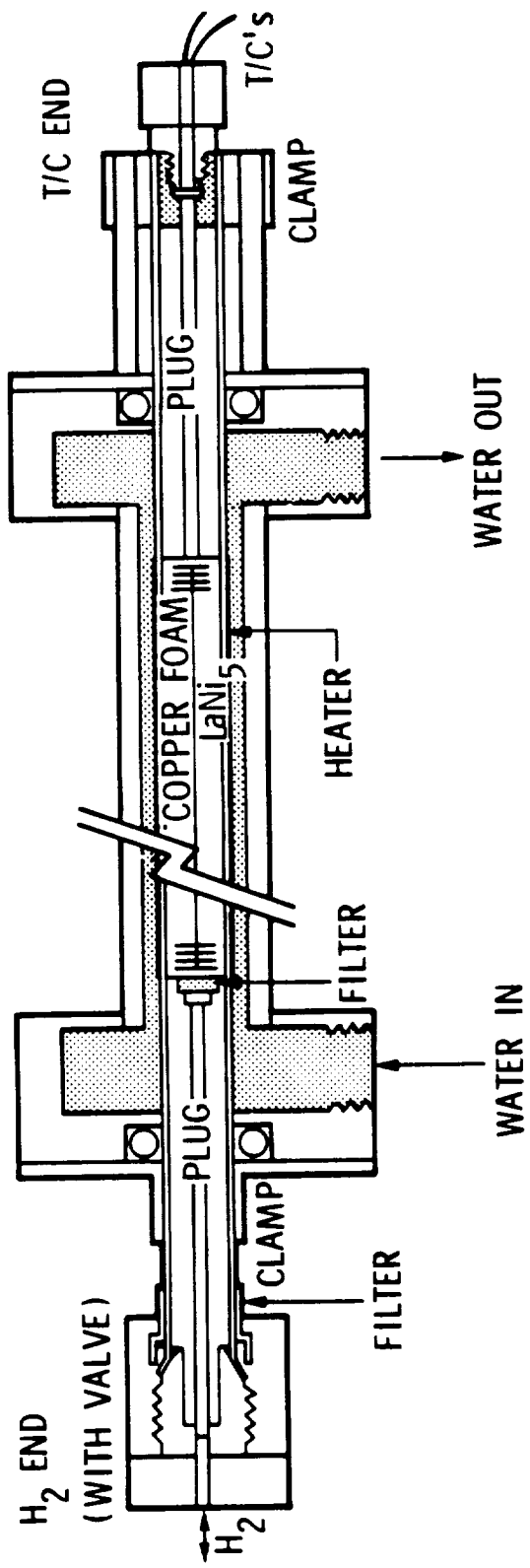

FIGURE 5 MACC COMPRESSOR ASSEMBLY

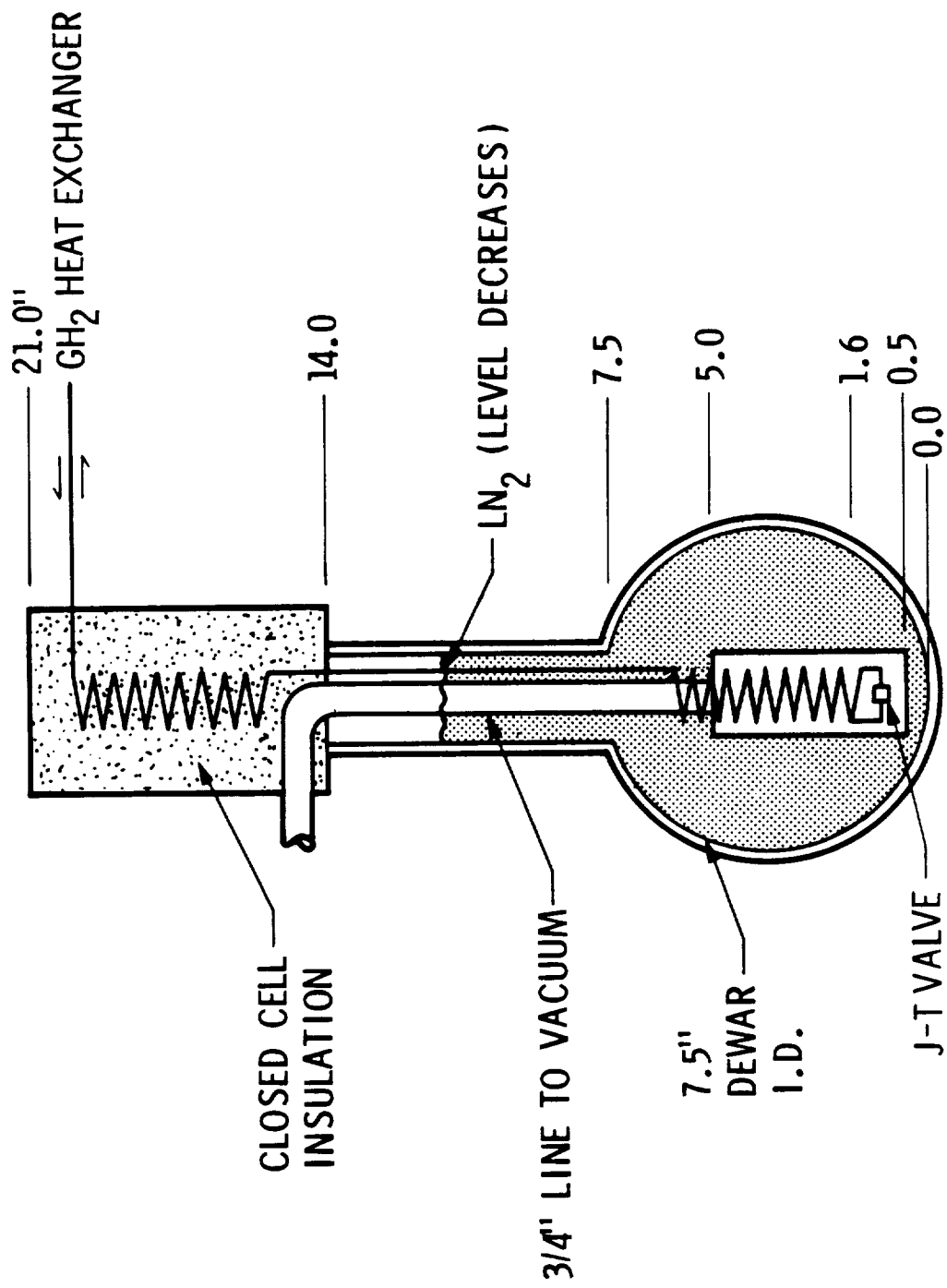

FIGURE 6 JOULE THOMSON/HEAT EXCHANGER ASSEMBLY

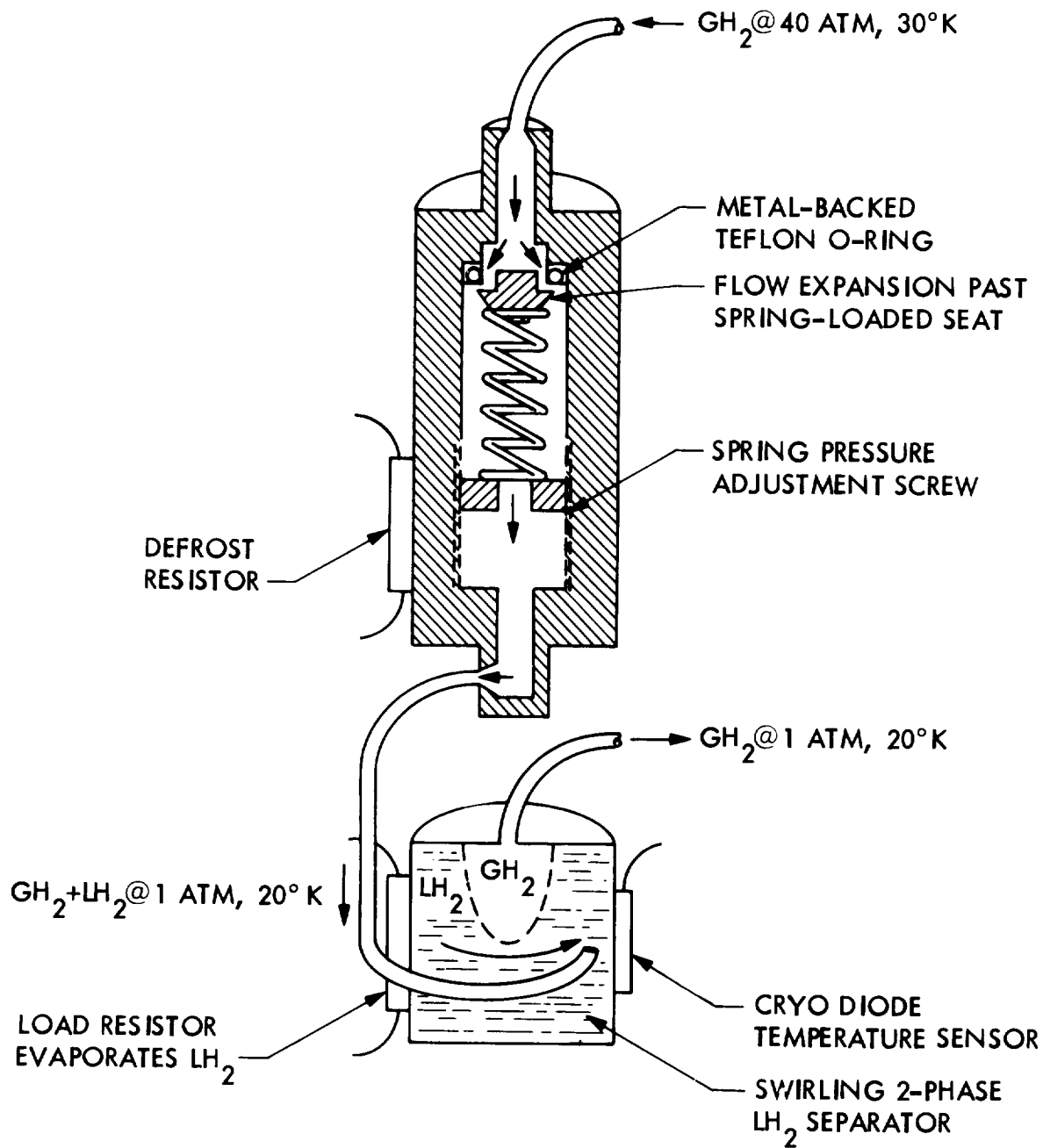

Figure 7. Joule Thompson Valve and Cryostat Assembly.

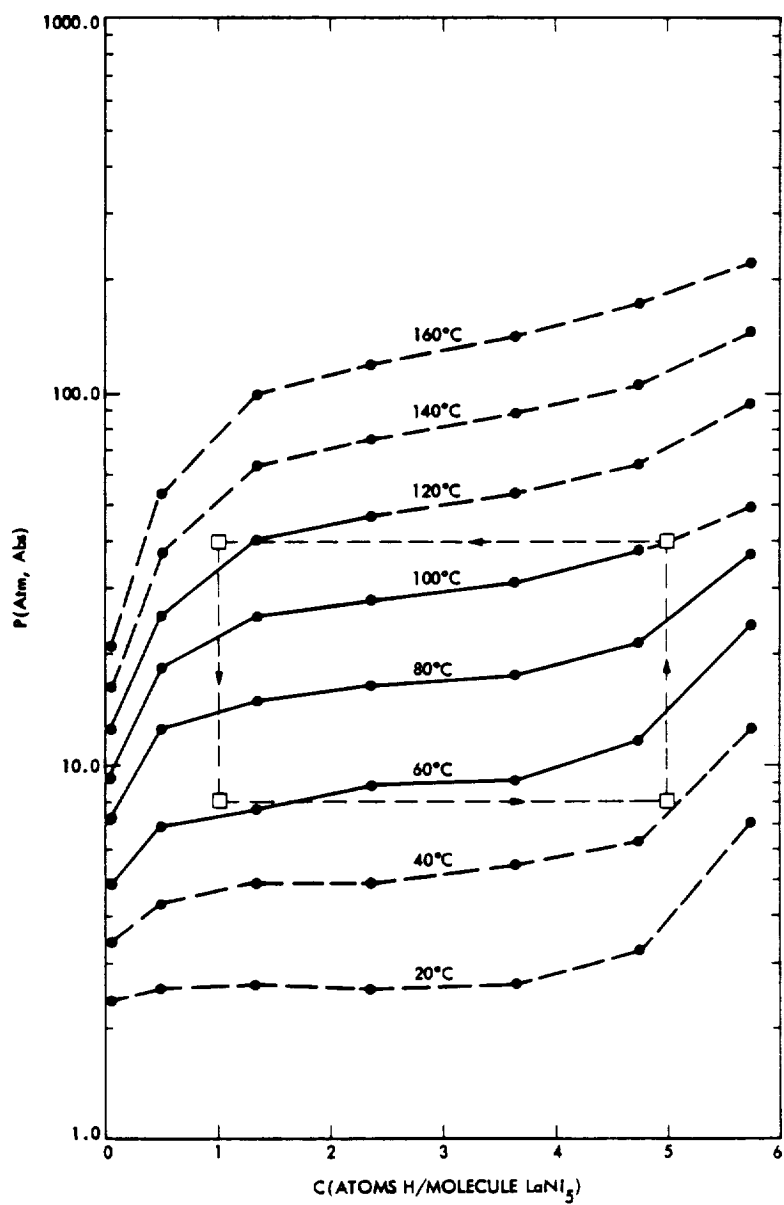

FIGURE 8 $\text{LaNi}_5\text{-H}_2$ ABSORPTION ISOTHERMS

REFERENCES

1. Klein, G.A., and Jones, J. A., "Molecular Absorption Cryogenic Cooler for Liquid Hydrogen Propulsion Systems," Paper No. AIAA-82-0830, AIAA/ASME 3rd Joint Thermophysics, Fluids, Plasma and Heat Transfer Conference," June 7-11, 1982/St. Louis, Missouri.
2. Van Mal, H. H., and Maynheer, A., "Hydrogen Refrigerator for the 20K Region with a LaNi₅-Hydride Thermal Absorption Compressor for Hydrogen," Proceedings of the Fourth International Cryogenic Engineering Conference, IPC Science and Technology Press, Surrey, England, 1972.
3. Klein, G. A. and Jones J. A., "Cryogenic Propellant Storage Study," Submitted to AIAA 22nd Aerospace Sciences Meeting, Reno, Nevada, January 9-12, 1984.
4. Cohen, R. L., and Wernick, J. H., "Hydrogen Storage Materials Properties and Possibilities," Science, Volume 214, Number 4525, 4 December, 1981.
5. Goodell, Doug, "Stability of Rechargeable Hydriding Alloys During Extended Cycling" International Nickel Co., White Plains, New York. Publication pending in Journal of Less Common Metals.
6. Sigurdson, Katherine B., "A General Computer Model for Predicting the Performance of Gas Sorption Refrigerators," Second Biennial Conference on Refrigeration for Cryogenic Sensors and Electronic Systems," December 7 and 8, 1982, Goddard Space Flight Center, Greenbelt, Maryland.