

NASA Conference Publication 2294

NASA
CP
2294
c.1

STEP Experiment Requirements

0099236



LOAN COPY: RETURN TO
AFWL TECHNICAL LIBRARY
KIRTLAND AFB, N.M. 87117.

*Proceedings of a workshop held at
NASA Langley Research Center
Hampton, Virginia
June 29-July 1, 1983*

NASA



STEP Experiment Requirements

M. Larry Brumfield, *Compiler*
Langley Research Center

Proceedings of a workshop held at
NASA Langley Research Center
Hampton, Virginia
June 29-July 1, 1983



National Aeronautics
and Space Administration

Scientific and Technical
Information Branch

PREFACE

The NASA Office of Aeronautics and Space Technology (OAST) is pursuing a plan to develop a Space Technology Experiments Platform (STEP). Proposals for potential STEP experiments were solicited from a broad spectrum of the scientific community, including universities, industry, other government agencies, and other NASA centers. NASA Langley Research Center held a STEP Experiment Requirements Workshop on June 29 and 30 and July 1, 1983, at which experiment proposers were invited to present more detailed information on their experiment concept and requirements.

A feasibility and preliminary definition study had been conducted by NASA Langley Research Center. The preliminary definition of STEP capabilities was presented to attendees at the beginning of the workshop. Experiment proposers then presented reviews of their experiment concepts and expected requirements for support services. The overall purpose of the workshop was to refine the preliminary definition of STEP capabilities based on detailed review of potential experiment requirements. This document contains copies of most of the visual material presented by each participant, together with as much descriptive material as was provided to the compiler.

The use of trade names or names of manufacturers in this report does not constitute an official endorsement of such products or manufacturers, either expressed or implied, by the National Aeronautics and Space Administration.

M. Larry Brumfield
Langley Research Center

CONTENTS

PREFACE.....	iii
ATTENDEES.....	vii
SPACE TECHNOLOGY EXPERIMENTS PLATFORM (STEP) OVERVIEW.....	1
Jack E. Harris	
STEP MECHANICAL SYSTEMS.....	13
Obie H. Bradley, Jr.	
STEP ELECTRONIC SYSTEM DESIGN.....	35
R. H. Couch and J. W. Johnson	
STEP EXPERIMENT INTEGRATION.....	47
J. C. Moorman	
ANNOUNCEMENT OF OPPORTUNITY AND EXPERIMENT SELECTION PLANS.....	55
Larry D. Pinson	
SHUTTLE ON-ORBIT DYNAMICS.....	59
Stanley Fay	
THE EFFECTS OF THE SPACE ENVIRONMENT ON DAMPING MATERIALS AND DAMPING DESIGNS ON FLEXIBLE STRUCTURES.....	79
Matthew F. Kluesener	
DEPLOYABLE BEAM FLIGHT EXPERIMENT (MAST).....	103
Brantley R. Hanks and John L. Allen, Jr.	
ERECTABLE BEAM EXPERIMENT.....	121
Walter L. Heard, Jr.	
THE STEP/STACBEAM EXPERIMENT TECHNOLOGY DEVELOPMENT FOR VERY LARGE SOLAR ARRAY DEPLOYERS.....	135
Ron Samuels	
GENERAL REQUIREMENTS FOR SHUTTLE FLIGHT EXPERIMENTS.....	147
Edward F. Crawley	
MEASUREMENT OF PASSIVE MATERIAL DAMPING USING STEP.....	155
Don Edberg	
THERMAL ENERGY MANAGEMENT PROCESS EXPERIMENT.....	161
S. Ollendorf	
CANADIAN ATTITUDE SENSING EXPERIMENTAL PACKAGE (CASEP).....	165
A. H. Reynaud	
PHOTOVOLTAIC CONCENTRATOR POINTING DYNAMICS AND PLASMA INTERACTION STUDY.....	177
Theodore G. Stern	

LOW CONCENTRATION RATIO SOLAR ARRAY STRUCTURAL CONFIGURATION.....	185
S. J. Nalbandian	
DEVELOPMENT OF TEST ARTICLE BUILDING BLOCK (TABB) FOR DEPLOYABLE PLATFORM SYSTEMS.....	199
H. S. Greenberg and R. T. Barbour	
A DEPLOYABLE STRUCTURE AND SOLAR ARRAY CONTROLS EXPERIMENT FOR STEP.....	211
T. S. Nishimoto	
VIBRATION ISOLATION TECHNOLOGY EXPERIMENT	221
Claude R. Keckler	
INTEGRATED POWER/ATTITUDE CONTROL SYSTEM (IPACS) TECHNOLOGY EXPERIMENT.....	231
Claude R. Keckler	
INVESTIGATION OF ARTICULATED PANEL DYNAMICS.....	241
Clyde V. Stahle, Jr.	
STEP FLIGHT EXPERIMENTS LARGE DEPLOYABLE REFLECTOR (LDR) TELESCOPE.....	257
F. C. Runge	
LARGE DEPLOYABLE ANTENNA FLIGHT EXPERIMENT FOR THE SPACE TECHNOLOGY EXPERIMENTS PLATFORM (STEP).....	279
B. C. Tankersly and Thomas G. Campbell	
55-METER-STRUCTURE FLIGHT EXPERIMENT.....	301
John A. Garba, Robert Freeland, Ben K. Wada, Kirk J. O'Keefe, and Art Woods	
LARGE INFLATED-ANTENNA SYSTEM.....	311
W. F. Hinson and L. S. Keafer	
ADAPTIVE MICROWAVE REFLECTOR.....	325
J. W. Goslee	
MICROWAVE REFLECTOR CHARACTERIZATION USING SIMPLE INSTRUMENTS IN EVA.....	333
J. W. Goslee	
FLIGHT TEST OF A SYNTHETIC APERTURE RADAR ANTENNA USING STEP.....	339
D. G. Zimcik, F. R. Vigeron, and S. Ahmed	

ATTENDEES

<u>NAME</u>	<u>ORGANIZATION</u>
Irving Abel	NASA LaRC
Richard R. Adams	NASA LaRC
Shabeer Ahmed	Canada Dept. of Comm.
John L. Allen, Jr.	NASA LaRC
Anthony Amos	AFOSR
Jean-Noel Aubrun	Lockheed
Bryon Bailey	Rockwell
Dave Barnett	Martin Marietta
Marvin Beatty	NASA LaRC
Vaughan Behun	Kentron
Robert Benhabib	TRW
Michael Biss	Rockwell
Ernie Blair	Harris Corp.
Obie H. Bradley, Jr.	NASA LaRC
William J. Boyer	NASA LaRC
P. A. Broome	McDonnell Douglas
Thomas G. Campbell	NASA LaRC
Ron Capasso	Harris Corp.
Neil Chatterton	Teledyne Brown
Richard H. Couch	NASA LaRC
Edward Crawley	MIT
Kenneth H. Crumbly	NASA LaRC
William Davis	HRTextron
Ronald DeFrees	TRW
Don Edberg	Stanford Univ.
Richard Faison	NASA LaRC
Stanley Fay	Draper Lab
John Fink	TRW
Richard Foss	NASA LaRC
Anthony Fontana	NASA LaRC
Fred Fujimoto	General Dynamics
Richard Gualdoni	NASA Headquarters
L. Bernard Garrett	NASA LaRC
Stanley Greenberg	Rockwell
Capt. James L. Haines	AFWAL
William Hallauer	VPI
Brantley Hanks	NASA LaRC
Jack E. Harris	NASA LaRC
J. K. Haviland	Univ. of VA
Paul Heran	Lockheed
Irv Himmelberg	Rockwell
William F. Hinson	NASA LaRC
Garnett Horner	NASA LaRC
William F. Hunter	NASA LaRC
James W. Johnson	NASA LaRC
Thomas C. Jones	NASA LaRC
Hans Kampman	Grumman
Lloyd Keafer	NASA LaRC

Claude R. Keckler
Robert Kennedy
Matthew Kluesner
Howard Merchant
John Montgomery
Joseph C. Moorman
Paul Murphy
S. J. Nalbandian
Ted Nishimoto
Bob Noblitt
Kirk O'Keefe
Stanford Ollendorf
Richard S. Pappa
Ted Stern
Dennis Petley
Larry D. Pinson
Robert Plunkett
Anthony S. Potozky
Richard R. Price
Victor J. Profumo
A. H. Reynaud
A. R. Robertson
Fritz Runge
Ron Samuels
E. G. Snyder
Clyde Stahle
Robert L. Swain
Bill Tankersley
Lewis C. Thomas
Samuel Venneri
Ben Wada
Woody Wagner
Bill Walker
Nathan D. Watson
D. J. Weidman
Lt. Michael Wenkel
Joseph H. White
Richard Witt
Howard T. Wright
Henry Yang
D. G. Zimcik
W. Leonard Moyer
Martin M. Mikulas
Joe Andrews

NASA LaRC
Sperry
Univ. of Dayton
MerEnCo
Martin Marietta
NASA LaRC
Rockwell
Rockwell
Rockwell
Teledyne Brown
Lockheed
NASA GSFC
NASA LaRC
General Dynamics
NASA LaRC
NASA LaRC
Univ. of Minn.
Kentron
Grumman
Aerospace Corp.
Canada Dept. of Comm.
General Dynamics
McDonnell Douglas
Astro Research
Rockwell
GE
NASA LaRC
Harris Corp.
Lockheed
NASA Hdqts.
JPL
NASA LaRC
Boeing
NASA LaRC
NASA LaRC
USAF
Research Triangle Inst
Lockheed
NASA LaRC
Purdue Univ.
Canada Dept. of Comm.
TELOS
NASA LaRC
Harris Corp.

SPACE TECHNOLOGY EXPERIMENTS PLATFORM (STEP) OVERVIEW

Jack E. Harris
NASA Langley Research Center
Hampton, Virginia

CONCEPT CHART

This chart summarizes the Space Technology Experiments Platform (STEP) concept, showing STEP as the enabling link between the research community and the space environment made accessible by the Space Transportation System (STS). It identifies the constituent elements of the research community, lists the pertinent space environment attributes, and identifies the major guidelines applicable to establishing the specific STEP configuration.

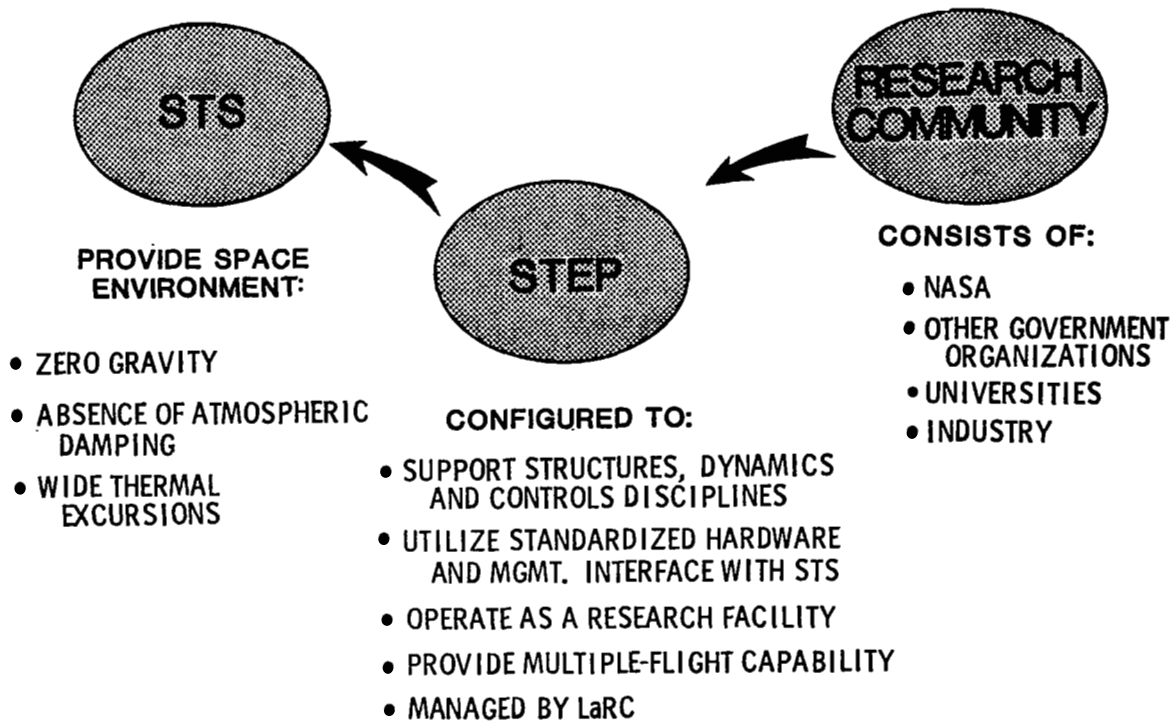

DEFINITION PROCESS CHART

This chart diagrams the system definition process followed during our Phase A study. It identifies the three classes of inputs, the three major design development activities, and the feedback mechanism used to close the loop on the process.

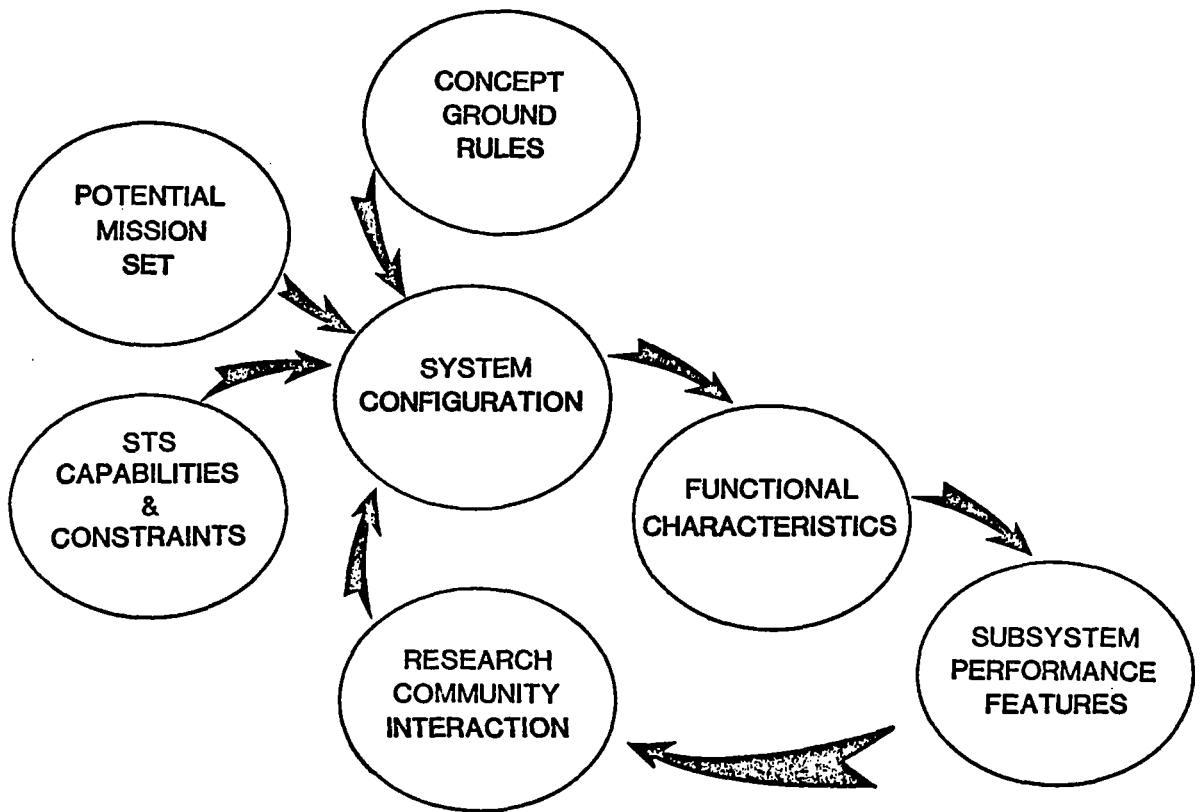

CONCEPT GROUND RULES

This chart restates the major ground rules guiding the configurational development.

- SUPPORT STRUCTURES DYNAMICS AND CONTROLS DISCIPLINE FLIGHT EXPERIMENTS
- UTILIZE STANDARDIZED HARDWARE AND MANAGEMENT INTERFACE WITH THE STS
- UTILIZE EXISTING HARDWARE/DESIGNS WHEREVER POSSIBLE
- PROVIDE FLEXIBILITY TO ACCOMMODATE A LARGE NUMBER OF UNDEFINED EXPERIMENTS
- DESIGN FOR MULTIPLE-FLIGHT CAPABILITY
- BE MANAGED BY LaRC

STS CAPABILITIES AND CONSTRAINTS

This chart identifies the data sources used and additional steps taken to ensure that an accurate representation of the STS capabilities and constraints was used in the definition process.

- UTILIZED STANDARD STS DOCUMENTATION AUGMENTED BY
 - PERSONAL CONTACTS
 - CONTRACT WITH MDTSCO

- REVIEWED STEP CONCEPT WITH APPROPRIATE OFFICES
 - HDQ'S SPACELAB PROGRAM OFFICE
 - HDQ'S SPACELAB FLIGHT DIVISION
 - JSC PAYLOAD INTEGRATION OFFICE
 - MSFC SPACELAB PROGRAM OFFICE

- ADDITIONAL CONTACTS WITH ROCKWELL INTERNATIONAL
 - PAYLOAD INTEGRATION
 - ORBITER IMPROVEMENT STUDIES

POTENTIAL MISSION SET

This chart pictorially identifies two types of experiments used to develop the initial set of detailed requirements. These experiment classes are undergoing detailed definition at the Langley Research Center (LaRC) and are believed to be highly representative, representing reasonable minimum and maximum cases.

STRUCTURES/CONTROLS INTERACTION

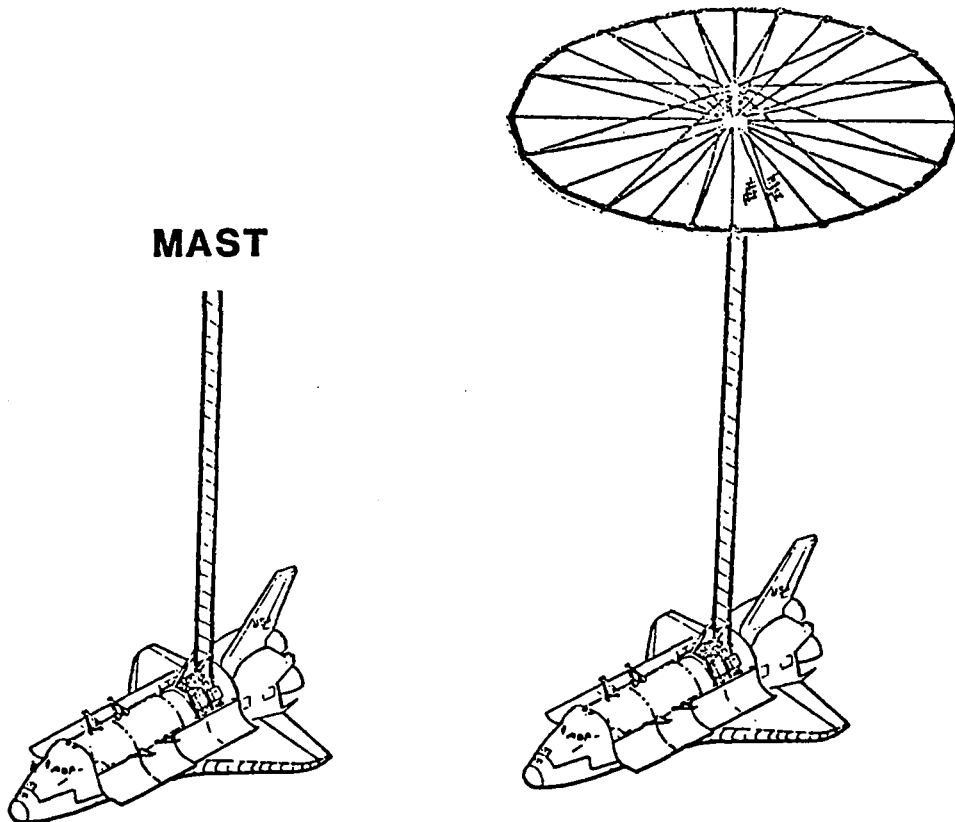

RESEARCH COMMUNITY INTERACTION

This chart identifies the major elements of the feedback process used to ensure that the STEP performance meets the needs of the potential users.

- OAST DEAR COLLEAGUE LETTER RELEASED
 - STIMULATE IDEAS FOR UTILIZATION OF STEP
 - IDENTIFY ADDITIONAL DESIGN REQUIREMENTS

- STEP/EXPERIMENTER WORKSHOP IN EARLY SUMMER '83
 - ATTENDEES SELECTED FROM NOTICE RESPONDEES
 - PROVIDED FORUM TO ITERATE STEP PERFORMANCE CAPABILITIES AND EXPERIMENT REQUIREMENTS

SYSTEM CONFIGURATION

This chart depicts the STEP system configuration. It identifies the key elements of the system and shows various combinations of the modular interface structure in concept with varying experiment configurations.

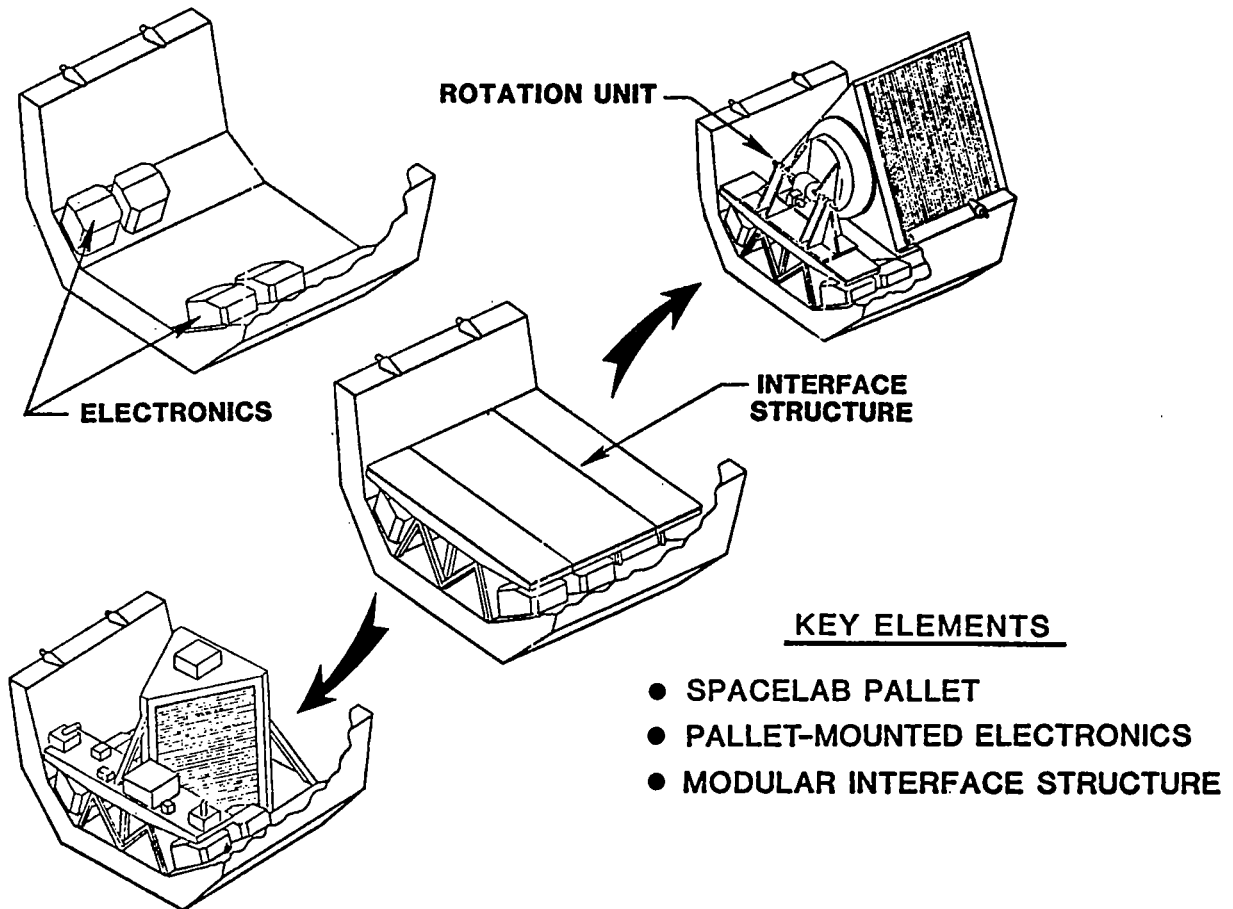

MECHANICAL FUNCTIONAL CHARACTERISTICS

This chart identifies the major functional characteristics attendant to the Spacelab pallet and interface structure and mechanism elements of the STEP system.

SPACELAB PALLET

- MECHANICAL SUPPORT AND ALIGNMENT FOR STEP ELECTRONICS AND INTERFACE STRUCTURE
- THERMAL COOLING FOR STEP ELECTRONICS AND STEP-MOUNTED EXPERIMENT ELECTRONICS
- STANDARDIZED MECHANICAL INTERFACE WITH SHUTTLE ORBITER

INTERFACE STRUCTURE AND MECHANISMS

- EXPERIMENT MOUNTING, LATCH AND RELEASE, CONTROLLED ROTATION AND SEPARATION
- EXPERIMENT WEIGHTS UP TO 2,000 kg
- PACKAGED EXPERIMENTS UP TO 3 METERS IN DIAMETER AND VARIABLE LENGTH UP TO 12 METERS

ELECTRONICS FUNCTIONAL CHARACTERISTICS

This chart identifies the major functional characteristics attendant to the electronics elements of STEP. The characteristics are grouped under the major functional categories of command and control, data handling and storage, and power.

COMMAND AND CONTROL

- PREPROGRAMMED COMMAND SEQUENCING
- MASS STORAGE ... COMMAND SEQUENCE PROGRAM LIBRARY
- INTERACTIVE EXPERIMENT CONTROL ... STATUS AND LIMIT CHECKING
- REAL-TIME ON-BOARD CONTROL ... AFD KEYBOARD AND DISPLAY
- PREPROGRAMMED PARAMETER MODIFICATION ... ORBITER UPLINK

DATA HANDLING AND STORAGE

- COLLECTION, FORMATTING, AND RECORDING OF DATA
- DOWNLINK OF DATA ... ORBITER Ku AND S BAND LINKS
- REAL-TIME DISPLAY ... AFD KEYBOARD AND DISPLAY
- ANALOG SIGNAL CONDITIONING

POWER

- SWITCHING AND DISTRIBUTION
- 28 V DC
- AUX 28 V DC
- 110 V AC, 400 Hz, 3 PHASE

INTEGRATION STRATEGY

This chart diagrams the interrelationships between the Space Transportation System, STEP, and experiments that relate to the areas of integration. Interface documentation, combined analyses, reviews, and hardware flow are addressed.

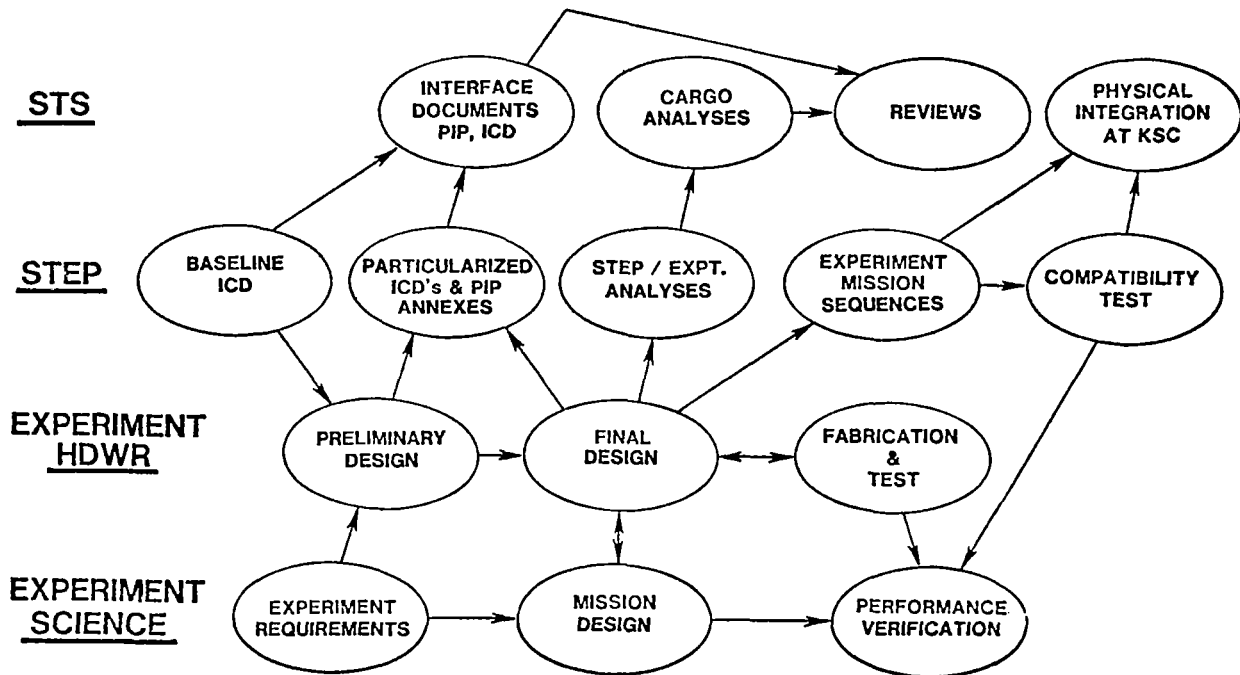

STEP MECHANICAL SYSTEMS

Obie H. Bradley, Jr.
NASA Langley Research Center
Hampton, Virginia

STEP SYSTEM CONFIGURATION

The key elements in the STEP system are depicted including the Spacelab pallet, a modular interface structure, and pallet-mounted electronics. Several concepts for potential experiments are illustrated.

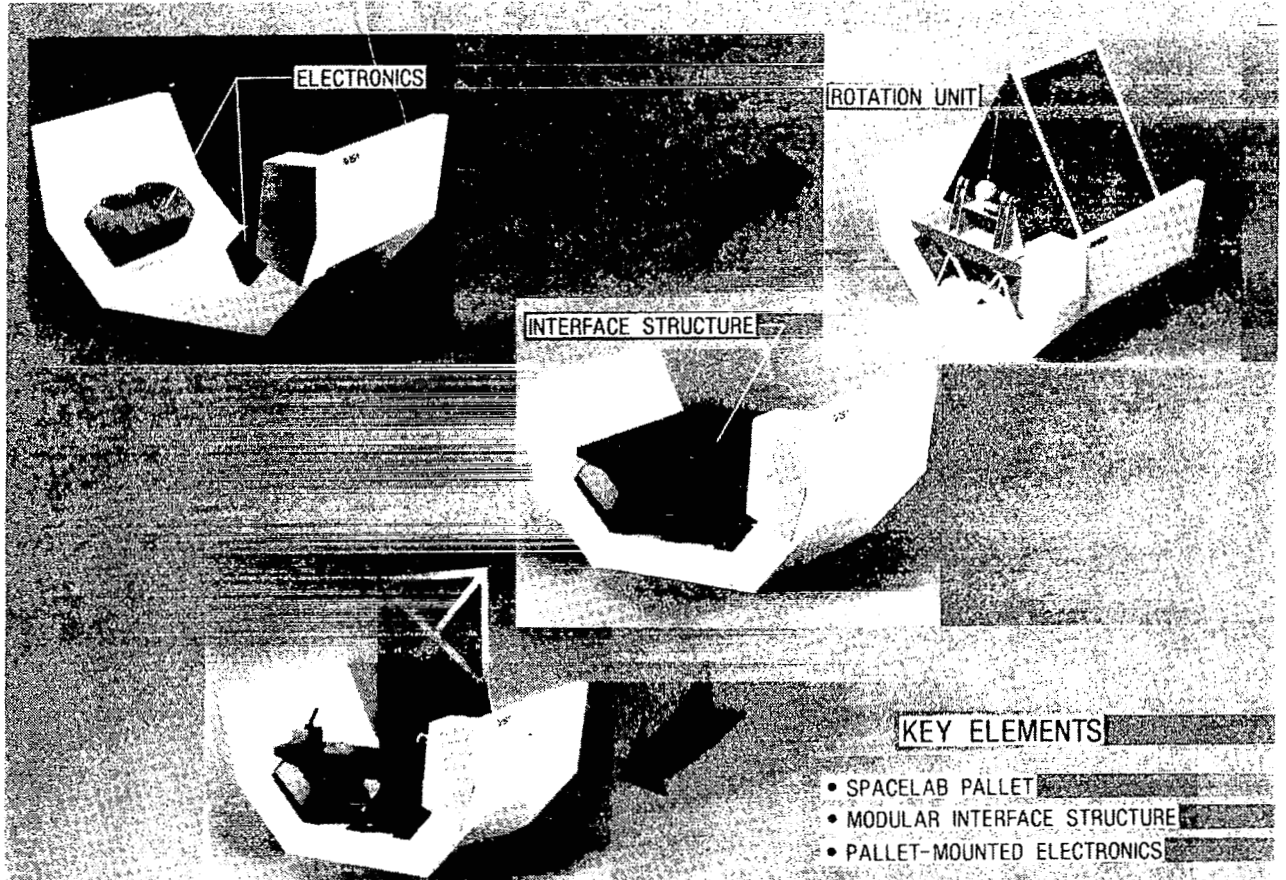

PRESENTATION TOPICS

- DESIGN OVERVIEW
- PRELIMINARY DESIGN DETAILS
- ANALYTICAL APPROACH/ENVIRONMENTAL REQUIREMENTS

DESIGN GOALS

- SUPPORT STRUCTURES, STRUCTURAL DYNAMICS AND CONTROL DISCIPLINES FLIGHT EXPERIMENTS
- MINIMIZE RELIANCE ON ORBITER SERVICES THAT INVOLVE COMPLEX OR LENGTHY INTEGRATION
- UTILIZE EXISTING HARDWARE/DESIGN WHEREVER POSSIBLE
- DESIGN FOR MULTIPLE-FLIGHT CAPABILITY
- PROVIDE FLEXIBILITY TO BE RESPONSIVE TO EVOLVING RESEARCH OPPORTUNITIES

PAYLOAD CARRIER OPTIONS CONSIDERED

- SPACELAB PALLET
- MODULAR PAYLOAD SUPPORT STRUCTURE (MPSS) MBB
- SPACELAB PALLET DERIVATIVES BAE
- MULTIPURPOSE EXPERIMENT SUPPORT STRUCTURE (MPSS) TELEDYNE BROWN
- EXPERIMENT SUPPORT SYSTEM LMSC

OPTION SELECTED

SPACELAB PALLET

RATIONALE

- PALLET STRUCTURE DEVELOPED AND SPACE QUALIFIED WITH FLIGHT EXPERIENCE IN THE SORTIE MODE
- MATCHES WEIGHT AND VOLUME NEEDS
- PHYSICAL AND MANAGEMENT INTERFACES DEVELOPED
- CONSISTENT WITH NASA/ESA AGREEMENTS

MECHANICAL FUNCTIONAL CHARACTERISTICS

SPACELAB PALLET

- MECHANICAL SUPPORT AND ALIGNMENT FOR STEP ELECTRONICS AND INTERFACE STRUCTURE
- THERMAL COOLING FOR STEP ELECTRONICS AND STEP-MOUNTED EXPERIMENT ELECTRONICS
- STANDARDIZED MECHANICAL INTERFACE WITH SHUTTLE ORBITER

INTERFACE STRUCTURE AND MECHANISMS

- EXPERIMENT MOUNTING, LATCH AND RELEASE, CONTROLLED ROTATION AND SEPARATION
- EXPERIMENT WEIGHTS UP TO 2,000 kgs
- PACKAGED EXPERIMENTS UP TO 3 METERS IN DIAMETER AND VARIABLE LENGTH UP TO 12 METERS

SPACELAB PALLET HARDWARE

- PALLET
- COLD PLATES, SUPPORT STRUCTURE, PLUMBING
- FREON PUMP
- PALLET MOUNTING PROVISIONS (IF DESIRED)

SPACELAB PALLETS

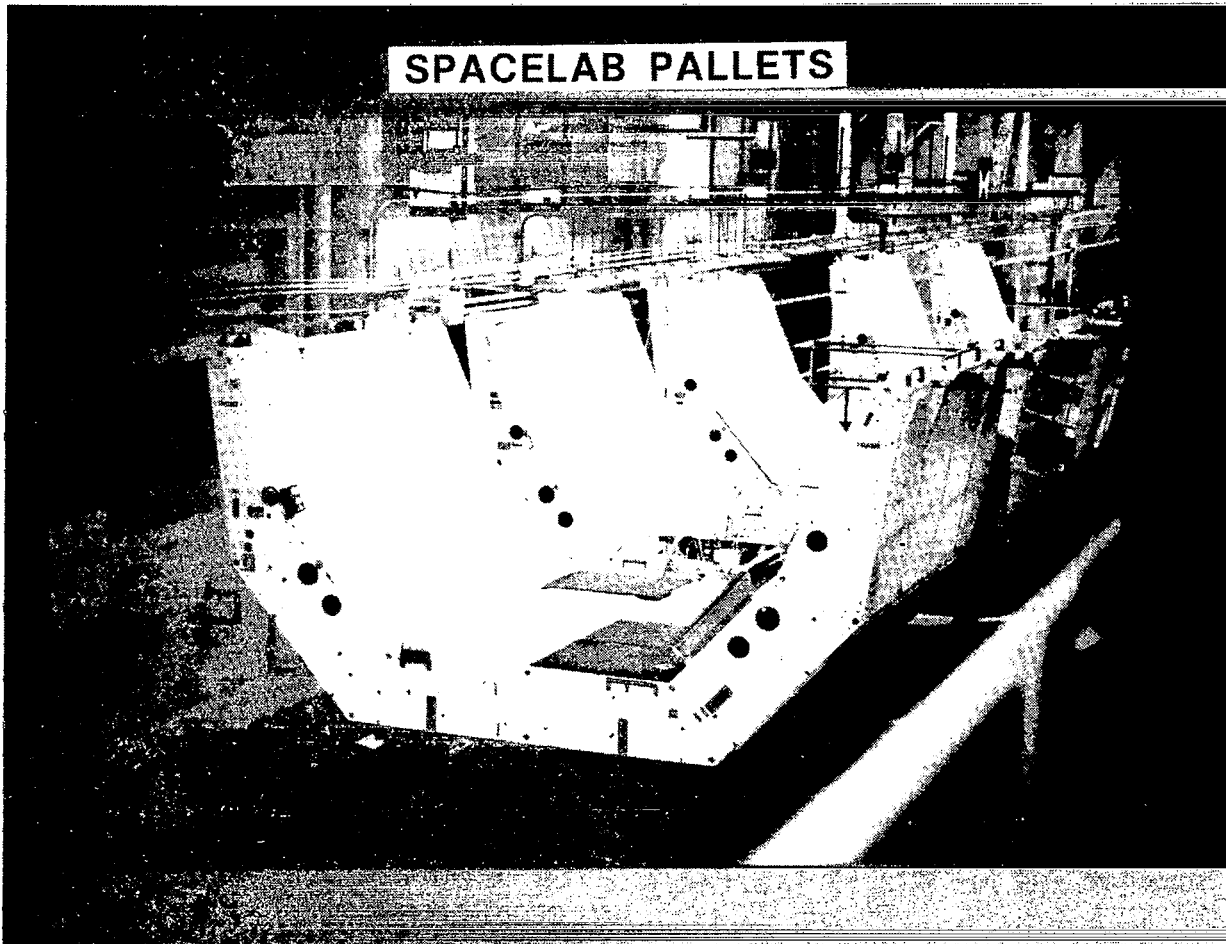

COLD PLATE AND SUPPORT STRUCTURE
MOUNTED ON A SPACELAB PALLET

"Cold plates" are heat exchanger plates that are part of the Spacelab pallet automatic thermal-control system. These elements will be utilized for thermal control of the STEP electronics and may also be used by experimenters.

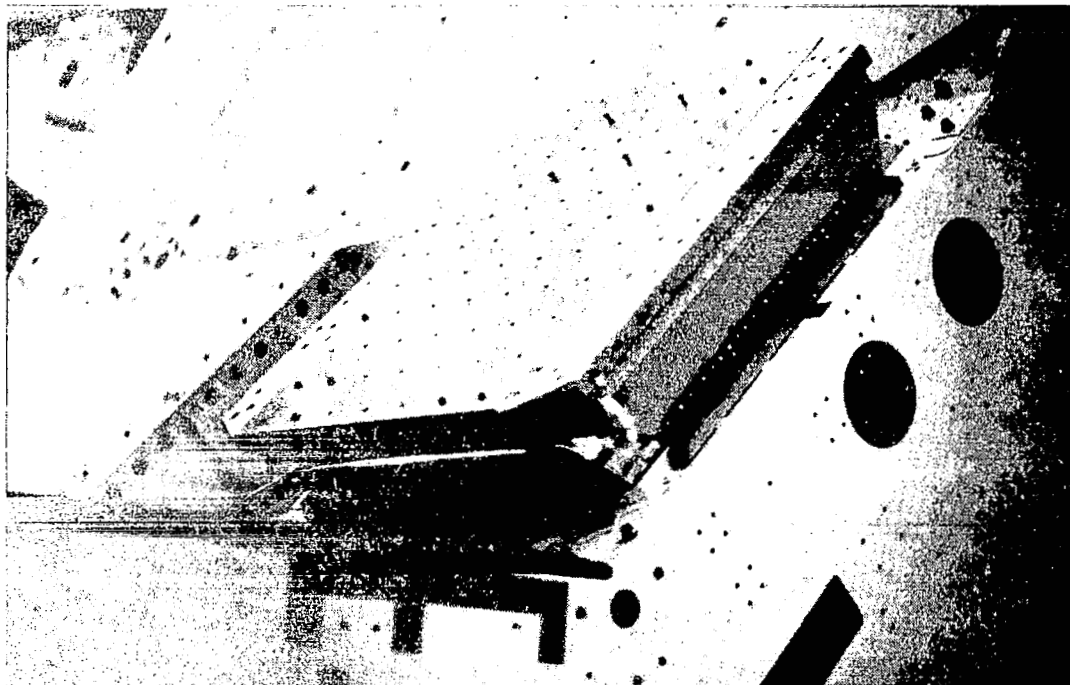

TYPICAL COLD PLATE

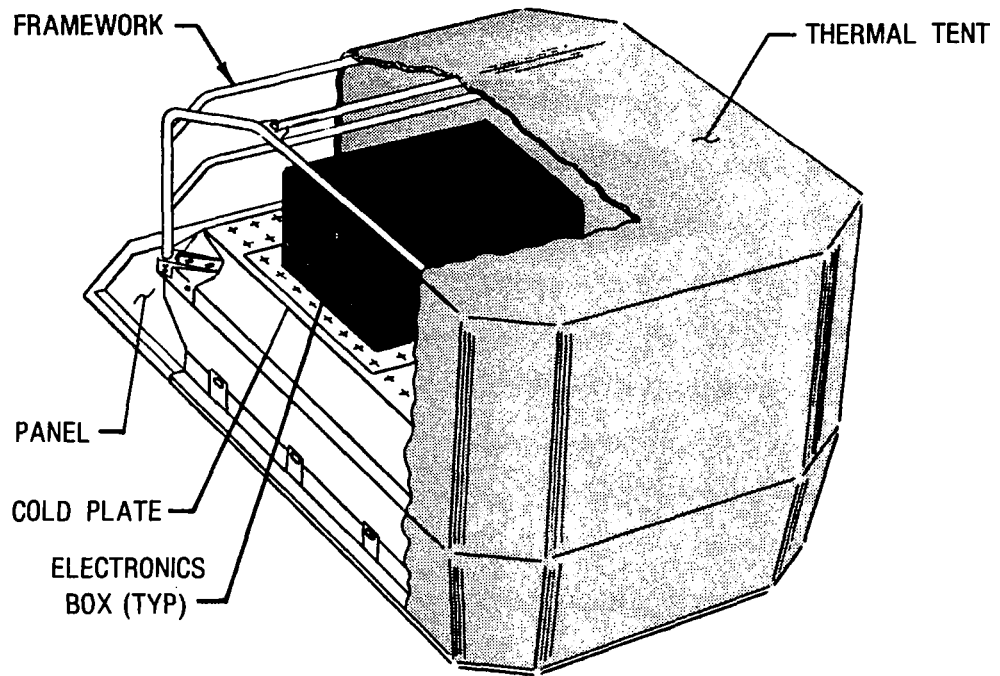

INTERFACE STRUCTURE AND MECHANISMS

- PLATFORM STRUCTURE
- ROTATION UNIT
- SEPARATION MECHANISM
- LATCH AND RELEASE MECHANISMS

PLATFORM STRUCTURE

- MODULAR DESIGN
- ALUMINUM AIRCRAFT CONSTRUCTION
- "BOLT-ON" ATTACHMENT
 - 96 PER FULL PLATFORM
 - 24 PER 1/4 PLATFORM

STEP STRUCTURE CONCEPTUAL LAYOUT

The STEP platform will be a modular structure. Three platform segments will be constructed which may be combined to form a number of different interface configurations. The segments are approximately one-fourth, one-half, and one-fourth of a pallet long, respectively. Attachment points will be provided through the top surface plates at the intersections of major internal structural members.

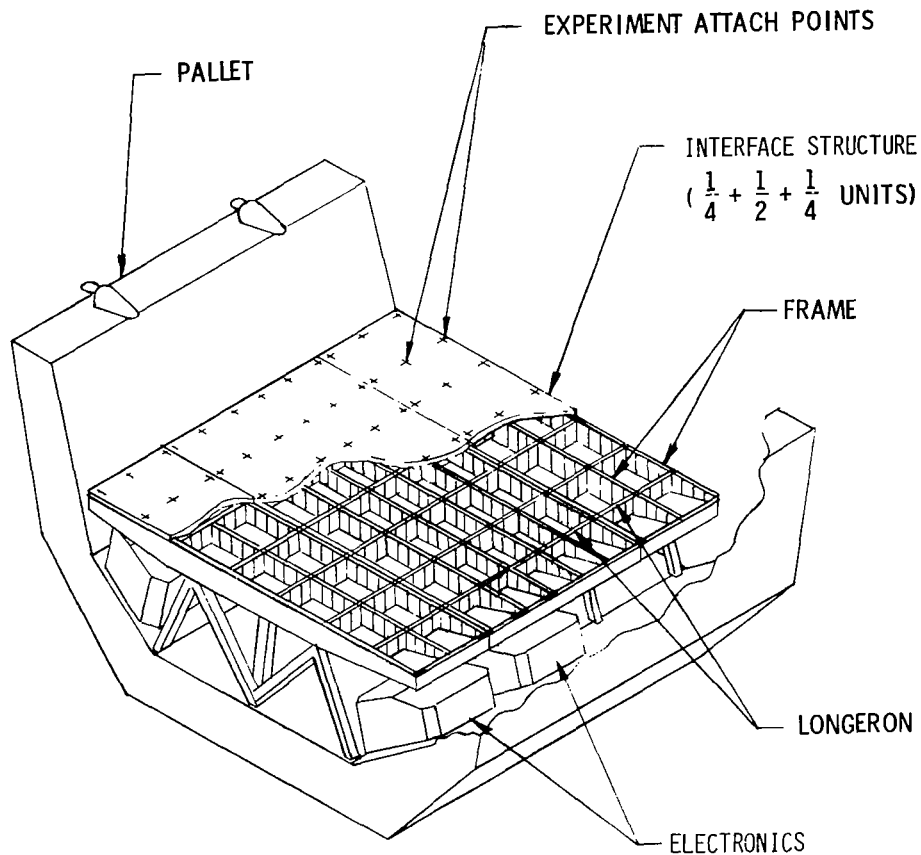

STEP MODULAR CONFIGURATIONS

A number of the STEP modular configurations are shown. Included are the most basic STEP configuration (Spacelab pallet plus STEP electronics) and five configurations using the modular platform structure elements.

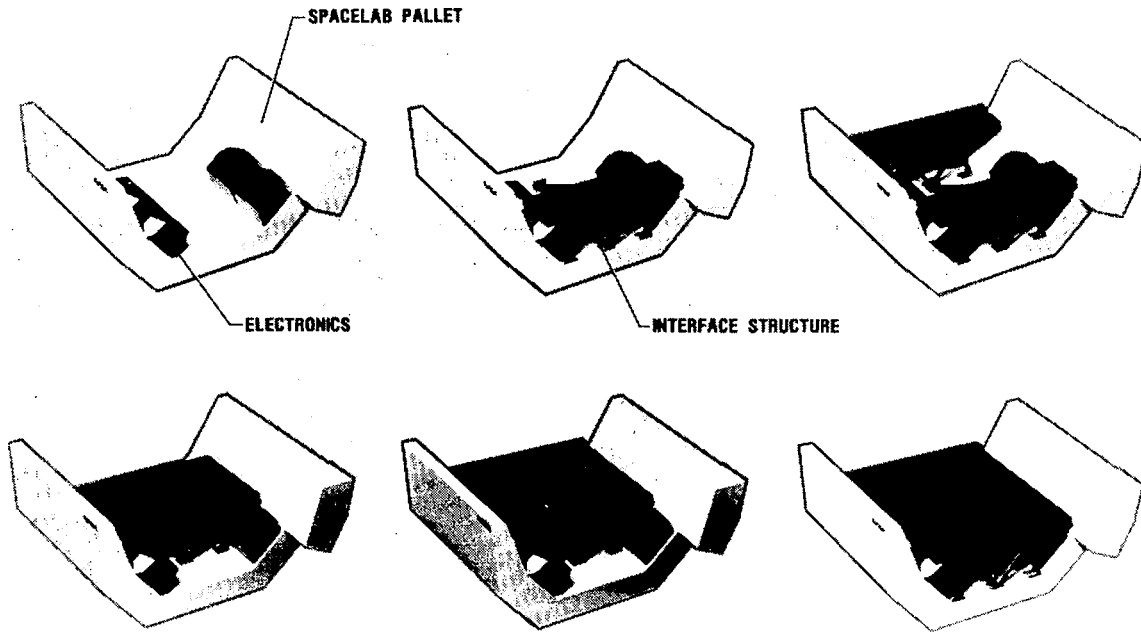

STEP/EXPERIMENT ENVELOPE

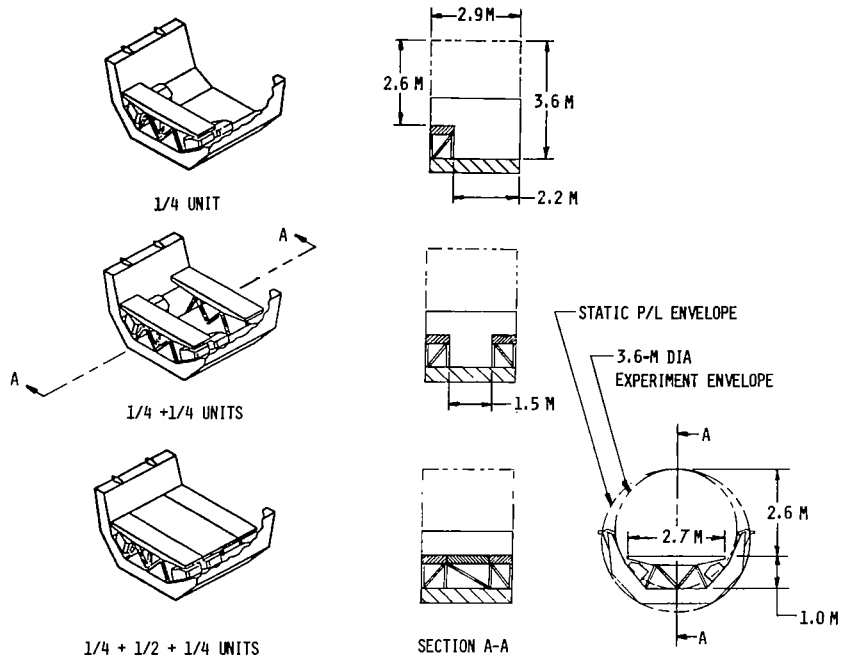

STEP GROWTH OPTION

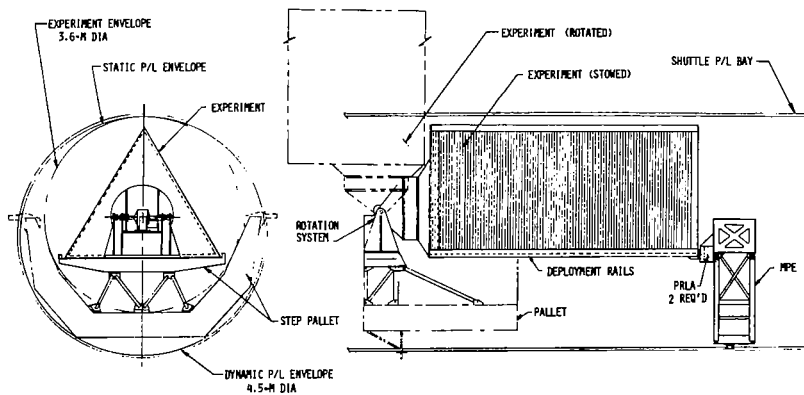

ROTATION UNIT

- SINGLE-AXIS ROTATION
- CONVENTIONAL REDUCER DRIVE DESIGN

STEP ROTATION MECHANISM

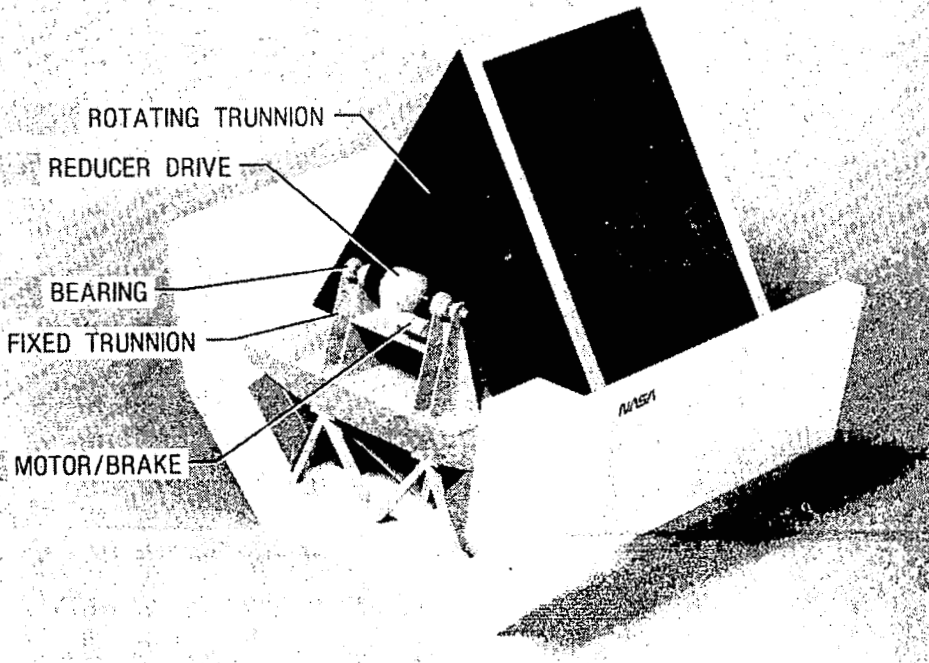

EXPERIMENT MOUNTED ON STEP ROTATION MECHANISM

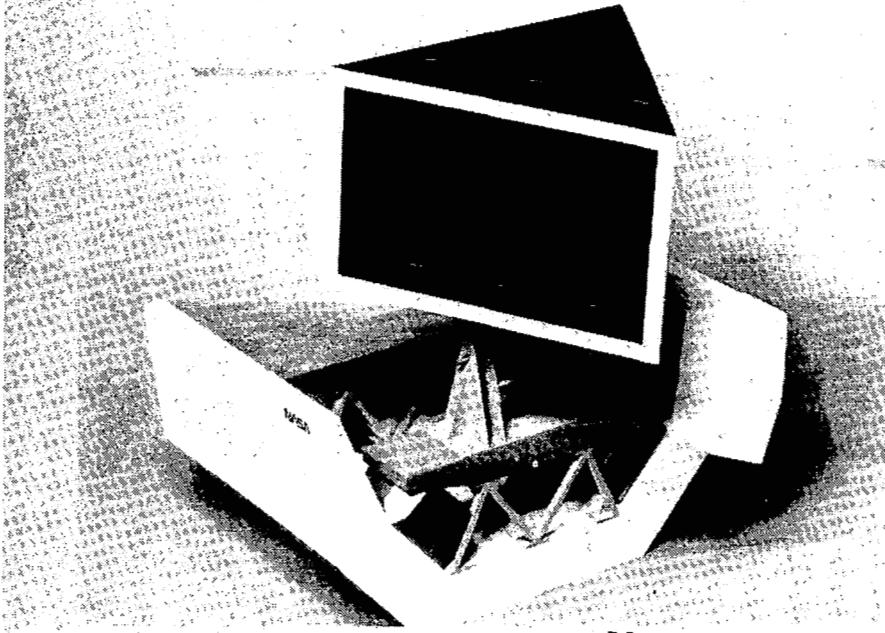

SEPARATION MECHANISMS

- PLATFORM-MOUNTED EXPERIMENTS
 - PYROTECHNIC BOLTS
 - UNIQUE MECHANISMS
- ROTATION UNIT MOUNTED EXPERIMENTS
 - MARMON BAND CLAMP DESIGN

LATCH AND RELEASE MECHANISMS

- STANDARD STS HARDWARE

THERMAL CONTROL

- PLATFORM STRUCTURE - PASSIVE CONTROL
(COATINGS, INSULATION)
- ROTATION MECHANISM - PASSIVE CONTROL
(INSULATION, HEATERS)
- ELECTRONICS - ACTIVE CONTROL (FREON, LOOP)

TYPICAL STEP PALLET AUTOMATIC THERMAL CONTROL SYSTEM BASELINE SCHEMATIC

Four cold plates within the automatic thermal control system (ATCS) will be reserved for STEP electronics. Up to six additional cold plates could be provided for experiment use. Four of these could be located on the Spacelab pallet and two could be placed on the STEP platform structure. Each cold plate provides a heat exchanger area approximately 20 inches by 30 inches.

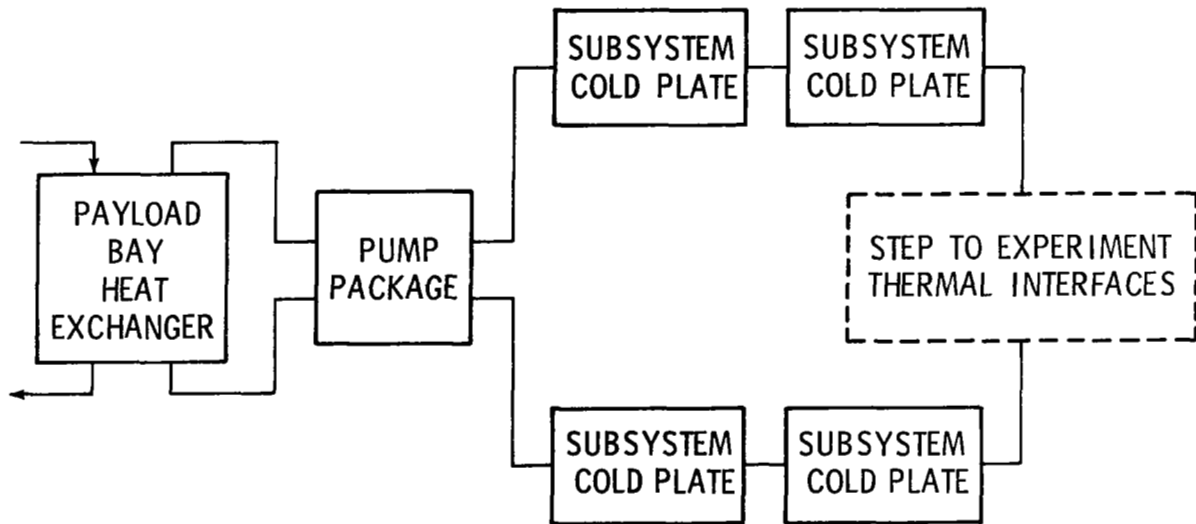

STEP ON-ORBIT HEAT REJECTION ALLOTMENT

Utilities within the Shuttle cargo bay are divided into one-fourth of the total increments. Assuming that STEP receives one standard allotment for heat rejection, a total of 7250 Btu/hr will be available for STEP and for experiments.

	Btu/hr	W
FREON PUMP	1194	350
STEP ELECTRONICS	1365	400
EXPERIMENTS	4691	1375
TOTAL ALLOTMENT	7250	2125

DESIGN ANALYSIS APPROACH

- STRUCTURAL (PATRANG, NASTRAN)
 - QUASI-STATIC ACCELERATIONS
 - DYNAMIC
- THERMAL (TRASYS, MITAS II)

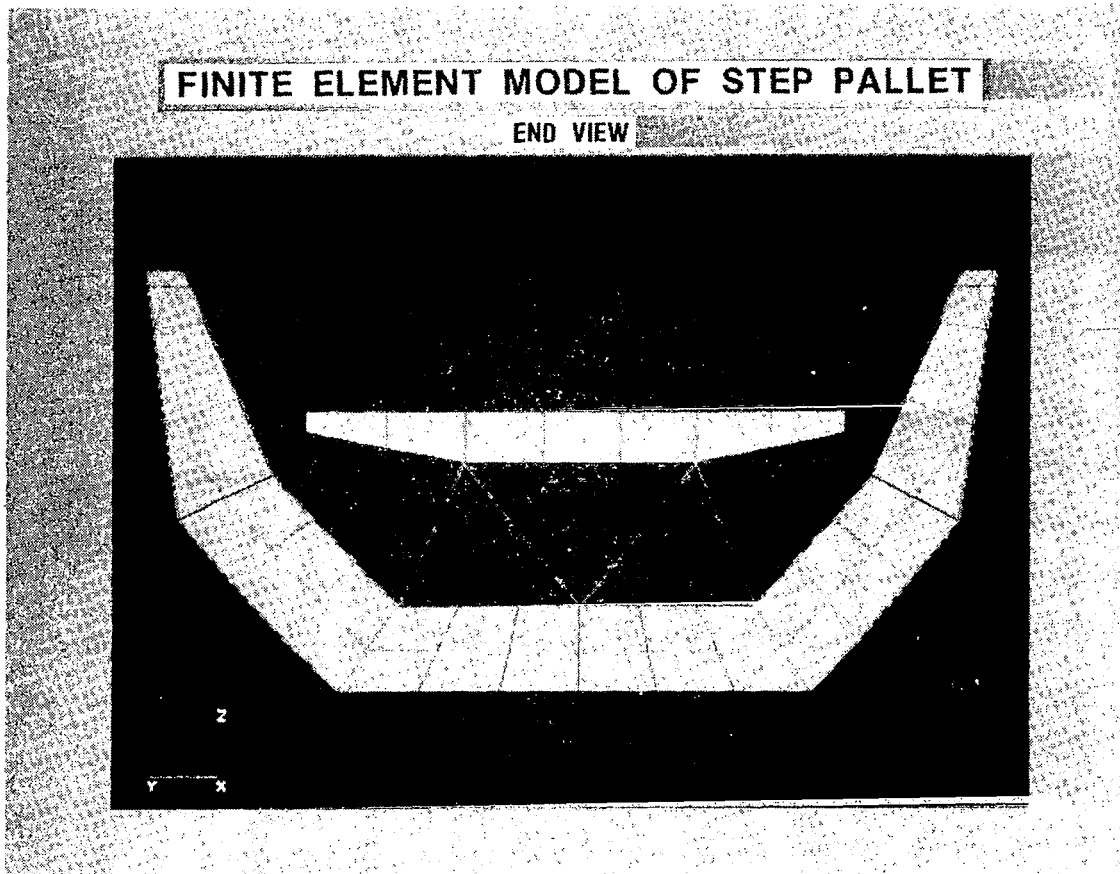

PATRANG MODEL OF STEP PALLET

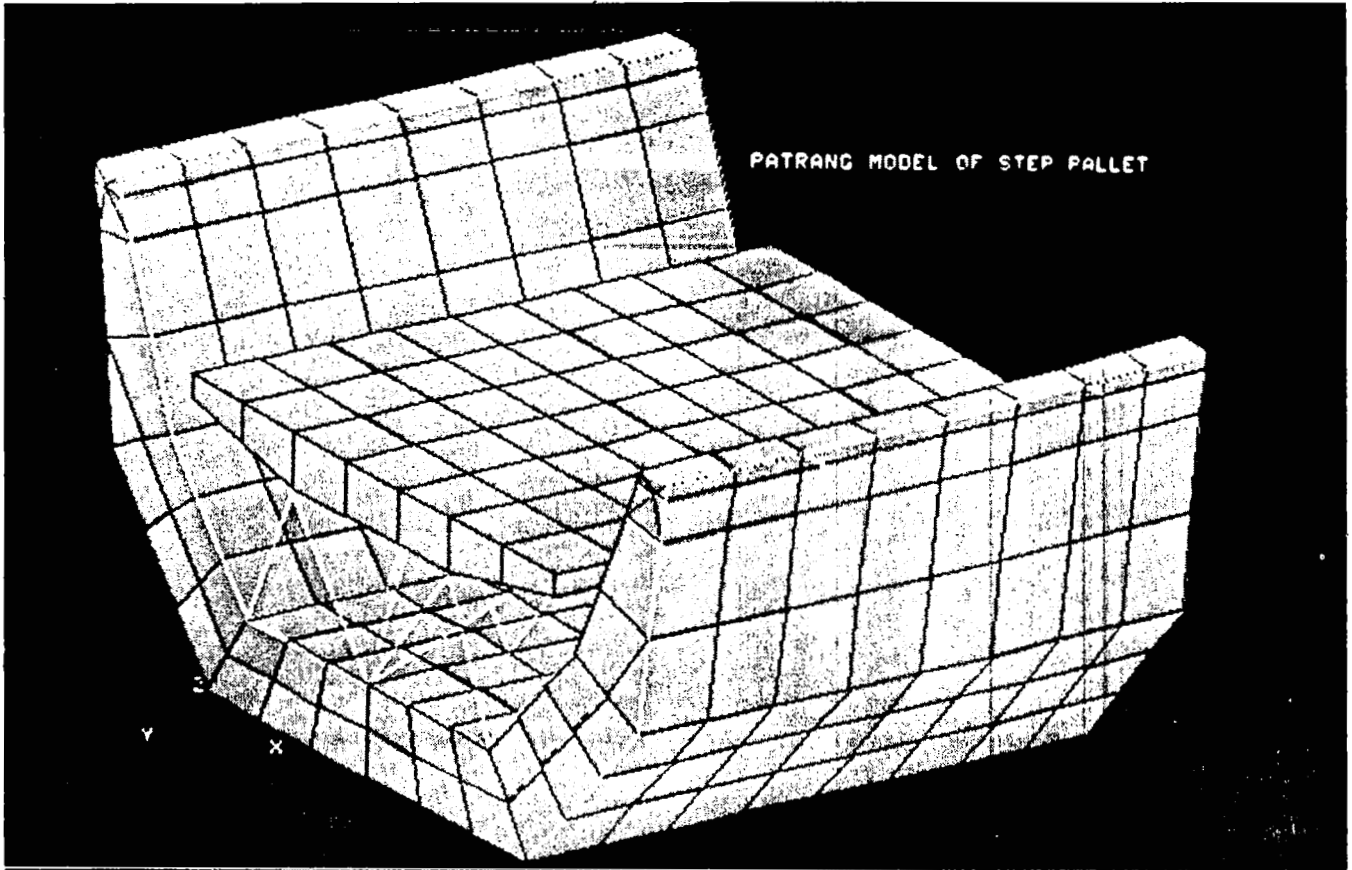

LINEAR QUASI-STATIC ACCELERATIONS

ACCELERATION CONDITION	X (G)	Y (G)	Z (G)
LIFT-OFF	+2.0 -5.0	±1.5	+4.7 -4.5
LANDING	+3.8 -4.5	±1.6	+6.0 -3.0

TRASYS SURFACE MODEL OF STEP PALLET

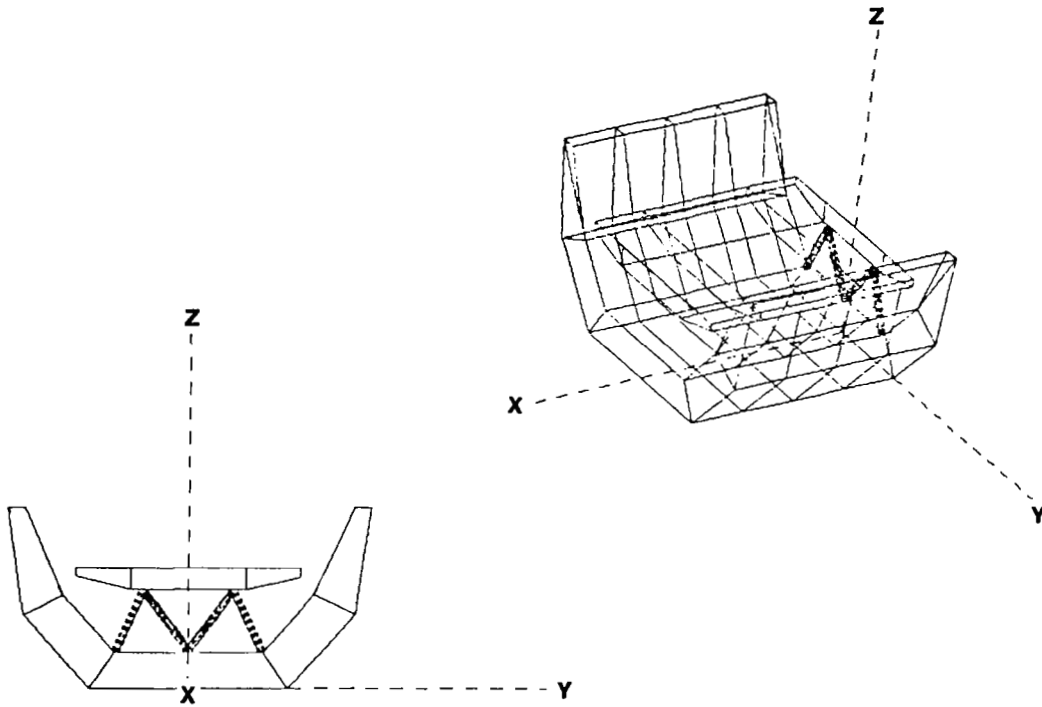

EXPERIMENT REQUIREMENTS SURVEY

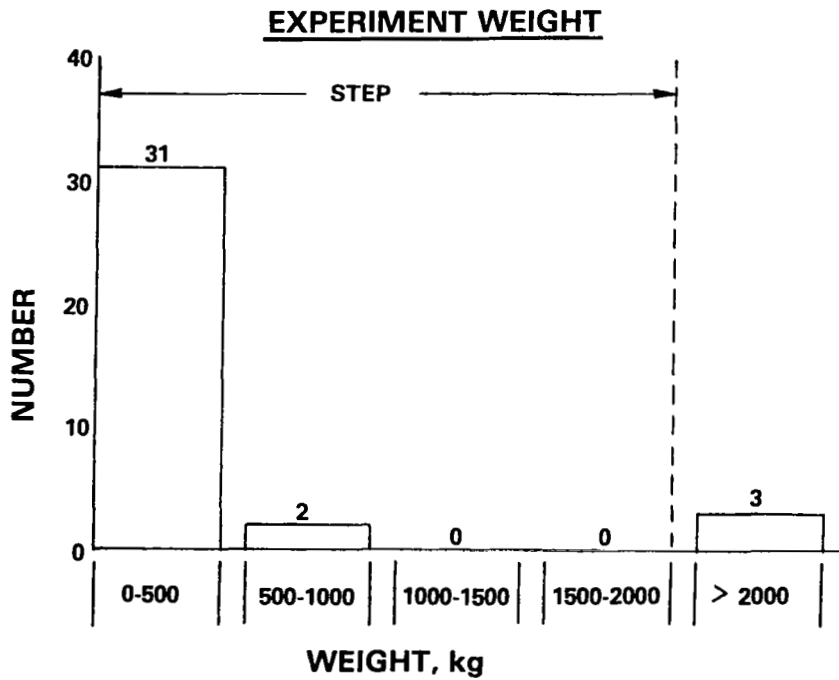

EXPERIMENT REQUIREMENTS SURVEY

ROTATION UNIT

NOT REQUIRED	41
REQUIRED	3

EXTRA LENGTH

NOT REQUIRED	36
REQUIRED	8

WHERE ARE WE?

- CONCEPTUAL POINT DESIGN BASED ON ESTIMATED REQUIREMENTS

WHERE DO WE GO FROM HERE?

- UPDATE REQUIREMENTS
- DEFINE
- DESIGN
- DEVELOPE



STEP ELECTRONIC SYSTEM DESIGN

R. H. Couch and J. W. Johnson
NASA Langley Research Center
Hampton, Virginia

INTRODUCTION

- SYSTEM DESIGN GOALS
- EXISTING PALLET SYSTEMS
- ORBITER ACCOMMODATIONS
- STEP SYSTEM DESIGN
- STEP SYSTEM CAPABILITIES
- EXPERIMENT REQUIREMENTS ANALYSIS

DESIGN GOALS

- SUPPORT STRUCTURES, STRUCTURAL DYNAMICS AND CONTROLS DISCIPLINE FLIGHT EXPERIMENTS
- MINIMIZE RELIANCE ON ORBITER SERVICES THAT INVOLVE COMPLEX OR LENGTHY INTEGRATION
- UTILIZE EXISTING HARDWARE/DESIGN WHEREVER POSSIBLE
- DESIGN FOR MULTIPLE-FLIGHT CAPABILITY
- PROVIDE FLEXIBILITY TO BE RESPONSIVE TO EVOLVING RESEARCH OPPORTUNITIES

EXISTING PALLET SYSTEMS

- MDM PALLET
 - DERIVED FROM ORBITAL FLIGHT TEST SYSTEM HARDWARE

- IGLOO PALLET
 - DESIGNED FOR USE ON SPACE LAB FLIGHTS

PALLET COMPARISON

	MDM	IGLOO
● COMMAND/CONTROL	-	+
● DATA MANAGEMENT	-	+
● POWER	+	+
● MIXED CARGO COMPATIBLE	+	-
● AVAILABILITY	+	-
+ SUFFICIENT		
- INSUFFICIENT		

STS ACCOMMODATIONS

- STANDARD ACCOMMODATIONS
 - THOSE STS RESOURCES CONVENIENTLY DIVISIBLE INTO QUARTERS
 - AVAILABLE TO STS USERS WITHOUT ADDITIONAL COST
- NONSTANDARD ACCOMMODATIONS
 - THOSE STS RESOURCES NOT CONVENIENTLY DIVISIBLE
 - AVAILABLE ON AN "AS REQUIRED" BASIS, USUALLY WITH ADDITIONAL COST

ORBITER AVIONICS BLOCK DIAGRAM

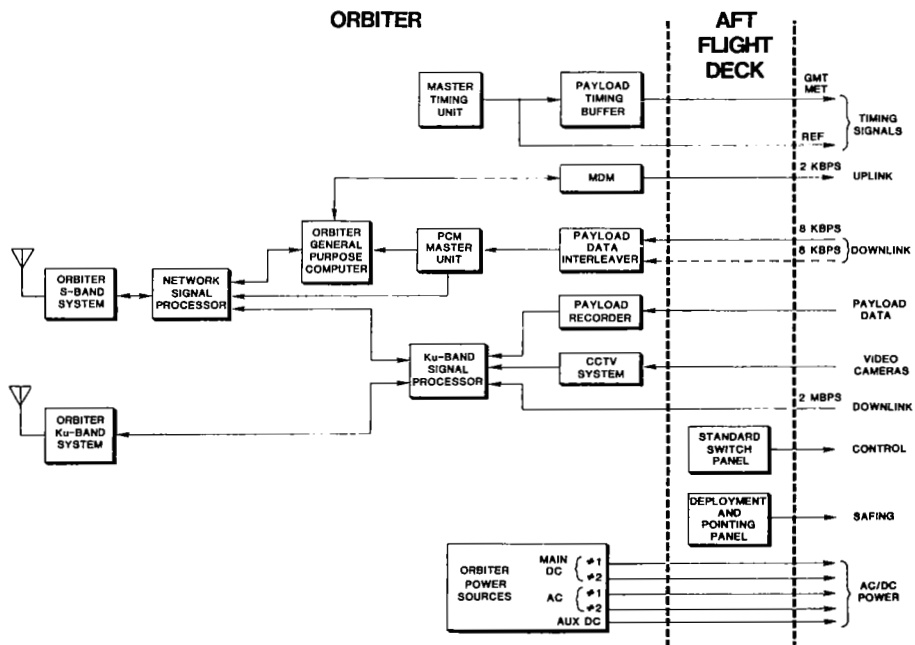

STS CAPABILITIES

- STANDARD ACCOMMODATIONS
 - DC POWER
 - AFT FLIGHT DECK STANDARD SWITCH PANEL
 - PAYLOAD DATA INTERLEAVER CHANNEL
 - PAYLOAD RECORDER CHANNELS
 - TIMING SIGNALS (GMT, MET)
 - MDM INTERFACE

- NONSTANDARD ACCOMMODATIONS
 - AUXILIARY DC POWER
 - AC POWER
 - PAYLOAD SAFING FUNCTIONS
 - CCTV MONITOR/VIDEO RECORDING
 - Ku-BAND SIGNAL PROCESSOR/TDRSS

- STEP WILL PROVIDE, AS A STEP-STANDARD ACCOMMODATION, PHYSICAL CONNECTION TO THE ABOVE NONSTANDARD STS ACCOMMODATIONS

STS OPERATIONAL CONSTRAINTS

- CREW AVAILABILITY
- MIXED CARGO MODE OPERATIONS
- TDRSS COVERAGE AVAILABILITY
- TOTAL ENERGY CONSIDERATIONS

ELECTRONICS FUNCTIONAL CHARACTERISTICS

COMMAND AND CONTROL

- PREPROGRAMMED COMMAND SEQUENCING
- MASS STORAGE ... COMMAND SEQUENCE PROGRAM LIBRARY
- INTERACTIVE EXPERIMENT CONTROL ... STATUS AND LIMIT CHECKING
- REAL-TIME ON-BOARD CONTROL ... AFD KEYBOARD AND DISPLAY
- PREPROGRAMMED PARAMETER MODIFICATION ... ORBITER UPLINK

DATA HANDLING AND STORAGE

- COLLECTION, FORMATTING, AND RECORDING OF DATA
- DOWNLINK OF DATA ... ORBITER Ku AND S BAND LINKS
- REAL-TIME DISPLAY ... AFD KEYBOARD AND DISPLAY
- ANALOG SIGNAL CONDITIONING

POWER

- SWITCHING AND DISTRIBUTION
- 28 V DC
- AUX 28 V DC
- 110 V AC, 400 Hz, 3 PHASE

STEP FUNCTIONAL BLOCK DIAGRAM

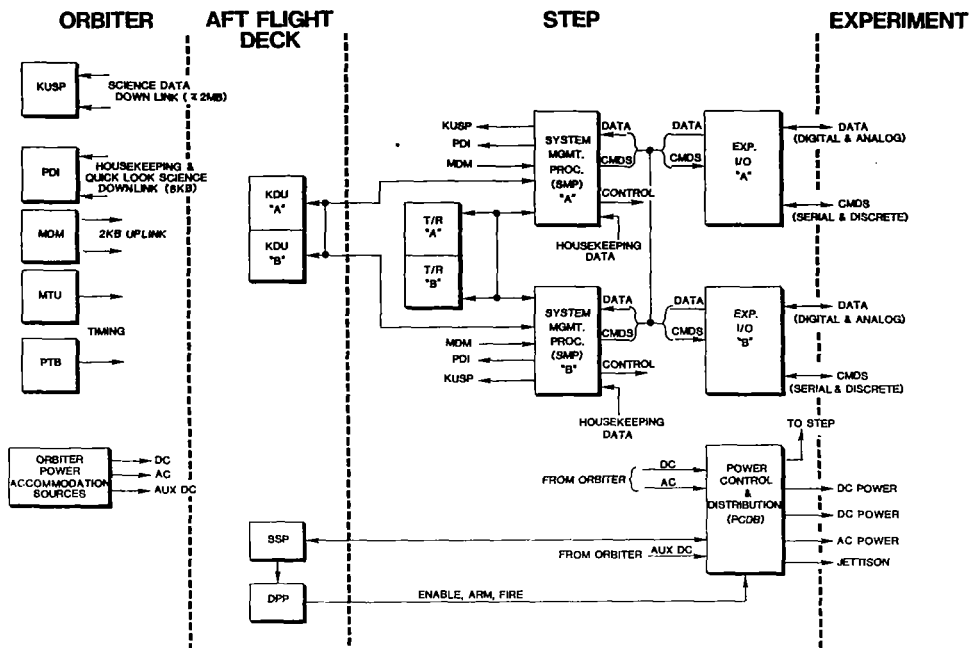

SUBSYSTEM PERFORMANCE FEATURES

PROCESSORS

- o UPLINK 2 KBPS
- o DOWNLINK
 - SCIENCE 2 MBPS
 - HOUSEKEEPING AND QUICK LOOK 8 KBPS
- o ARCHITECTURE
 - 16 BIT MICROPROCESSORS
 - 64 K BYTES, EPROM
 - 64 K BYTES, RAM
 - PERIPHERAL I/F's
 - I/O UNITS
 - KEYBOARD AND DISPLAY UNITS
 - TAPE RECORDERS
 - DIRECT PROCESSOR I/F

SUBSYSTEM PERFORMANCE FEATURES

DIGITAL I/O

o COMMANDS

- o SERIAL 2 LINES, 1 MHz MAX/LINE
- o LOGIC LEVEL DISCRETES 32 LINES
- o HIGH-LEVEL DISCRETES 8 LINES
- o 2 MHz THROUGHPUT

o DATA

- o SERIAL 2 LINES, 1 MHz MAX/LINE
- o DISCRETE 32 LINES
- o 2 MHz THROUGHPUT

o TIMING

- o GMT
- o MET
- o CLOCK

ANALOG I/O

PROGRAMMABLE GAIN ON ALL CHANNELS

SENSORS REQUIRING BIAS 64

- BRIDGES, ACCELEROMETERS, THERMISTORS

SENSORS NOT REQUIRING BIAS 32

- CRYSTALS

THERMOCOUPLES 32

SUBSYSTEM PERFORMANCE FEATURES

TAPE RECORDERS

- o DATA RATE 16 KBPS - 2 MBPS
- o DATA VOLUME 2×10^9 BITS/RECORDER
- o RECORD AND REPRODUCE

KEYBOARD AND DISPLAY UNIT

- o FUNCTIONAL KEYBOARD
- o INITIATION OF STORED COMMAND SEQUENCES
- o ENGINEERING UNIT CONVERSION
- o TEXT AND GRAPHICS DISPLAY

POWER CONTROL & DISTRIBUTION

- o SERVICES TO EXPERIMENT
 - o DC - 2
 - o AC - 1
- o TOTAL POWER (AC AND DC)
 - o STEP 750 WATTS AVERAGE
 - o EXPERIMENT

	SINGLE SECTION	DOUBLE SECTION
	1.00 KW AVG.	2.75 KW AVG.
	2.05 KW PEAK	4.85 KW PEAK
- o AC POWER
 - o STEP 350 WATTS FOR COOLING PUMP
 - o EXPERIMENT TBD
- o TOTAL ENERGY 12.5 KW HR/DAY

EXPERIMENT REQUIREMENTS ANALYSIS

- FORTY-FOUR POTENTIAL EXPERIMENTS WITH AVERAGE 50% RESPONDING IN THE MAJOR CATEGORIES OF
 - AVERAGE POWER
 - PEAK POWER
 - DATA RATE
 - DATA VOLUME

EXPERIMENT POWER REQUIREMENTS

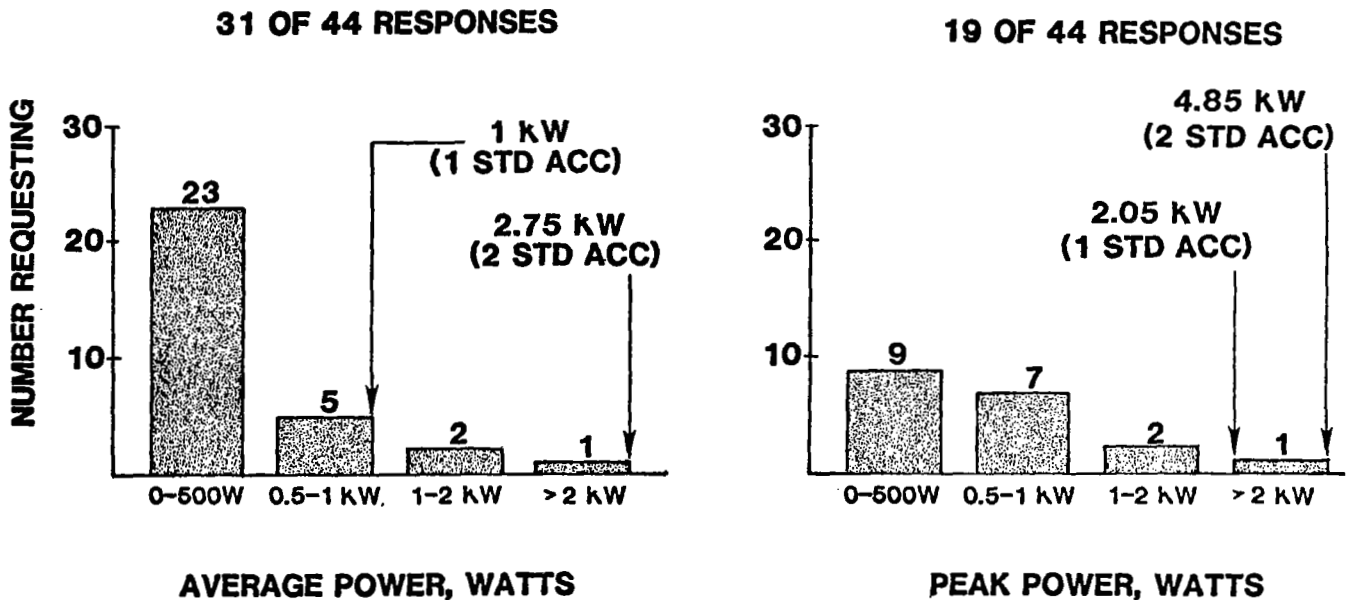

EXPERIMENT DATA REQUIREMENTS

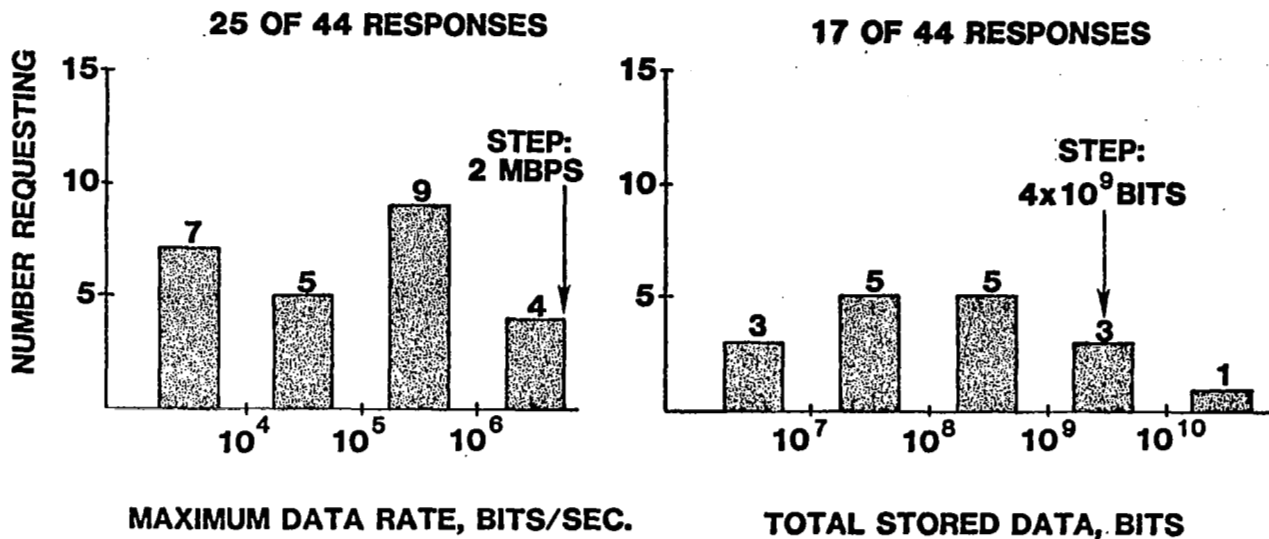

ELECTRONICS SUMMARY

- A CONCEPTUAL SYSTEM DESIGN HAS BEEN DEVELOPED
- THE DESIGN REPRESENTS A UNIQUE SET OF CAPABILITIES AND IS NOT DUPLICATIVE OF EXISTING SYSTEMS
- THE DESIGN MAKES EFFICIENT USE OF AVAILABLE ORBITER RESOURCES
- THE SYSTEM CAPABILITIES MEET OR EXCEED CURRENT IDENTIFIED POTENTIAL EXPERIMENT NEEDS
- EXPERIMENT REQUIREMENTS ANALYSIS WILL CONTINUE AS MORE INFORMATION BECOMES AVAILABLE

STEP EXPERIMENT INTEGRATION

J. C. Moorman
NASA Langley Research Center
Hampton, Virginia

STEP/EXPERIMENT INTEGRATION

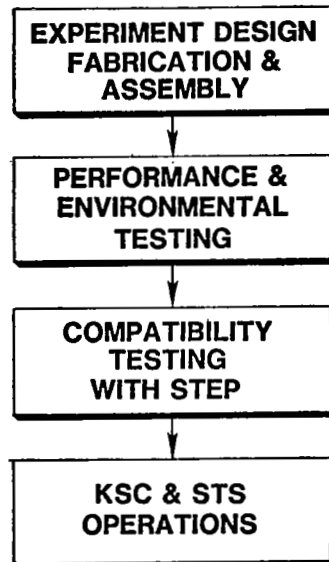

EXPERIMENT DESIGN, FABRICATION, AND ASSEMBLY

- o PRELIMINARY DESIGN
- o DEVELOPMENT TESTS
- o FINAL DESIGN
- o HARDWARE FABRICATION
- o COMPONENT TESTING AND SYSTEM ASSEMBLY
- o GROUND SUPPORT EQUIPMENT DESIGN, FABRICATION, AND TESTING
- o SOFTWARE DESIGN AND TESTING

EXPERIMENT PERFORMANCE AND ENVIRONMENTAL TESTING

- o FUNCTIONAL PERFORMANCE TESTING
- o INTERFACE VERIFICATION TESTING
 - MECHANICAL INTERFACE (FIT)
 - ELECTRICAL INTERFACE
 - ELECTROMAGNETIC INTERFERENCE (EMI/EMC)
- o ENVIRONMENTAL TESTING
 - STRUCTURAL (ACOUSTICAL OR VIBRATION)
 - STRUCTURAL (STEADY STATE)
 - THERMAL/VACUUM
- o SOFTWARE TESTING

STEP COMPATIBILITY TESTING

- o STEP/EXPERIMENT INTERFACE VALIDATION
 - MECHANICAL INTERFACE
 - ELECTRICAL INTERFACE
- o PROCEDURE VALIDATION
 - ASSEMBLY/DISASSEMBLY PROCEDURES
 - KSC LEVEL IV PROCEDURES
- o SOFTWARE VALIDATION
 - STEP/EXPERIMENT SOFTWARE INTERACTION
 - FLIGHT SEQUENCE
 - DATA HANDLING AND PROCESSING
- o SPECIAL STEP/EXPERIMENT TESTS

SPACELAB PROCESSING
& LEVELS OF INTEGRATION

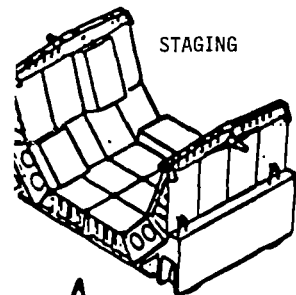

STAGING

STAGING - PREPARATION OF EXPERIMENT ELEMENTS AND SPECIAL EXPERIMENT SECTIONS FOR INTEGRATION.

LEVEL IV - INTEGRATION AND CHECKOUT OF EXPERIMENT EQUIPMENT WITH INDIVIDUAL EXPERIMENT MOUNTING ELEMENTS (e.g., RACKS AND PALLET SEGMENTS).

LEVEL III - COMBINATION AND INTEGRATION OF ALL EXPERIMENT MOUNTING ELEMENTS (e.g., RACKS, RACK SETS AND PALLET SEGMENTS) WITH EXPERIMENT EQUIPMENT ALREADY INSTALLED.

LEVEL II - INTEGRATION AND CHECKOUT OF THE COMBINED EXPERIMENT EQUIPMENT AND EXPERIMENT MOUNTING ELEMENTS (e.g., RACKS, RACK SETS AND PALLET SEGMENTS) WITH THE FLIGHT SUBSYSTEM SUPPORT ELEMENTS (i.e., BASIC MODULE, IGLOO) AND EXTENSION MODULES, WHEN APPLICABLE.

POST MISSION PROCESSING - LANDING AND SAFING OPERATIONS, REMOVAL FROM ORBITER DISASSEMBLY, MAINTENANCE AND REVERIFICATION OF SUPPORT SYSTEMS AND PRESSURE ELEMENTS.

EXPERIMENT ELEMENT POST MISSION PROCESSING - ELEMENT DISASSEMBLY, EXPERIMENT REMOVAL, REFURBISH AND REVERIFY ELEMENT, BULKHEADS AND SPECIAL EXPERIMENT SECTIONS.

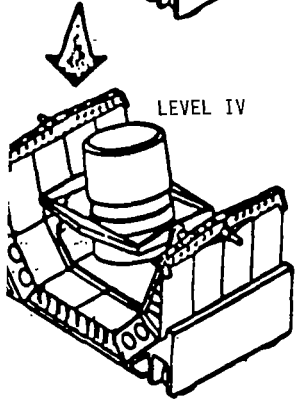

LEVEL IV

EXPERIMENT ELEMENT
POST MISSION PROCESSING

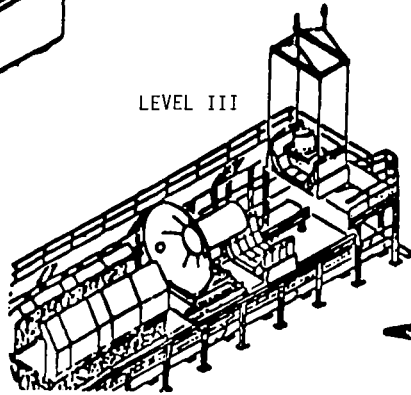
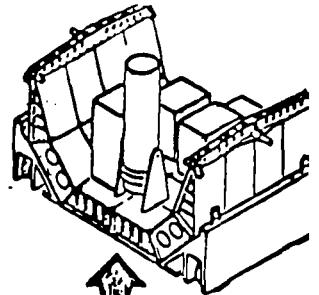

LEVEL III

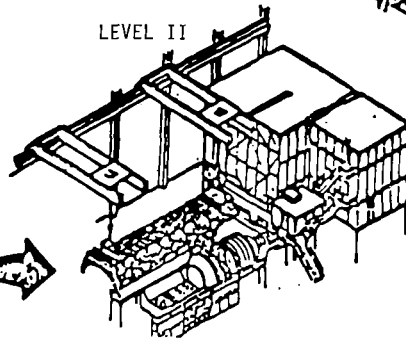

LEVEL II

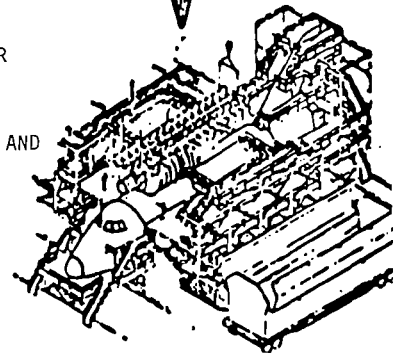

LEVEL 1 &
POST MISSION
PROCESSING

STEP/EXPERIMENT INTEGRATION INTERFACE DOCUMENTATION

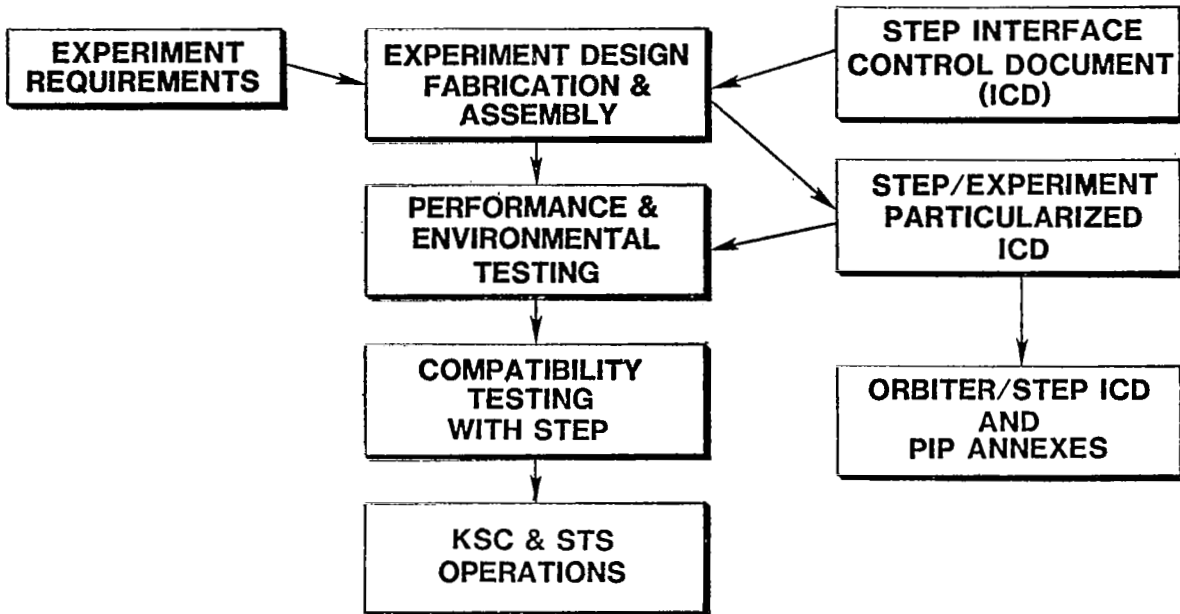

STS/PAYLOAD REQUIREMENTS DEFINITION DOCUMENTATION

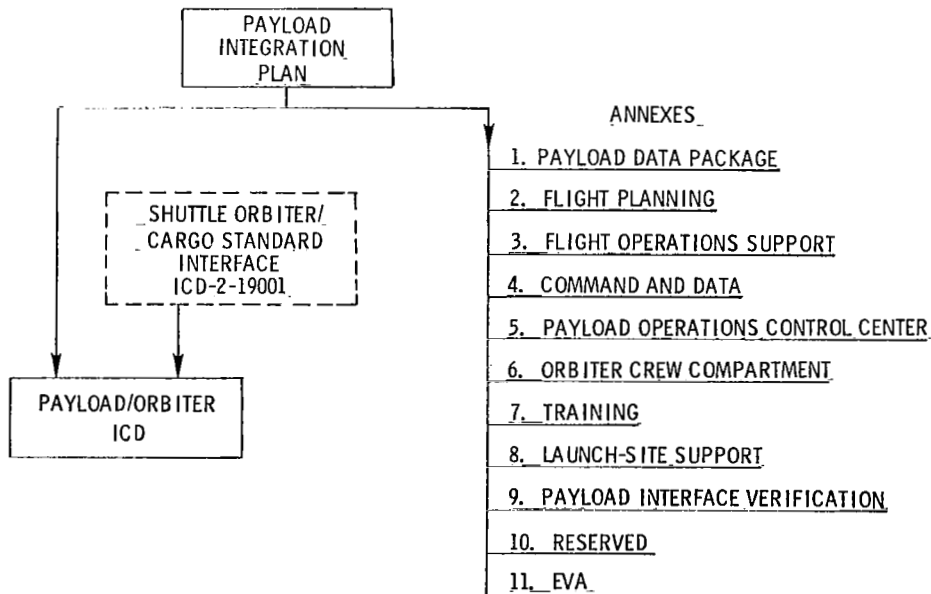

STEP/EXPERIMENT INTEGRATION

ANALYSIS REQUIREMENTS

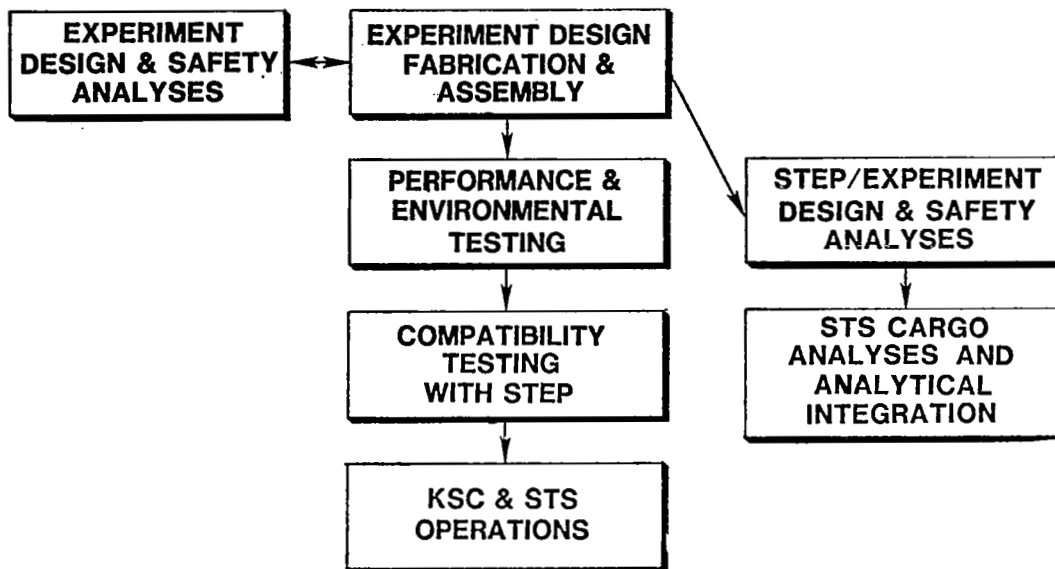

STEP/EXPERIMENT INTEGRATION

MISSION DESIGN

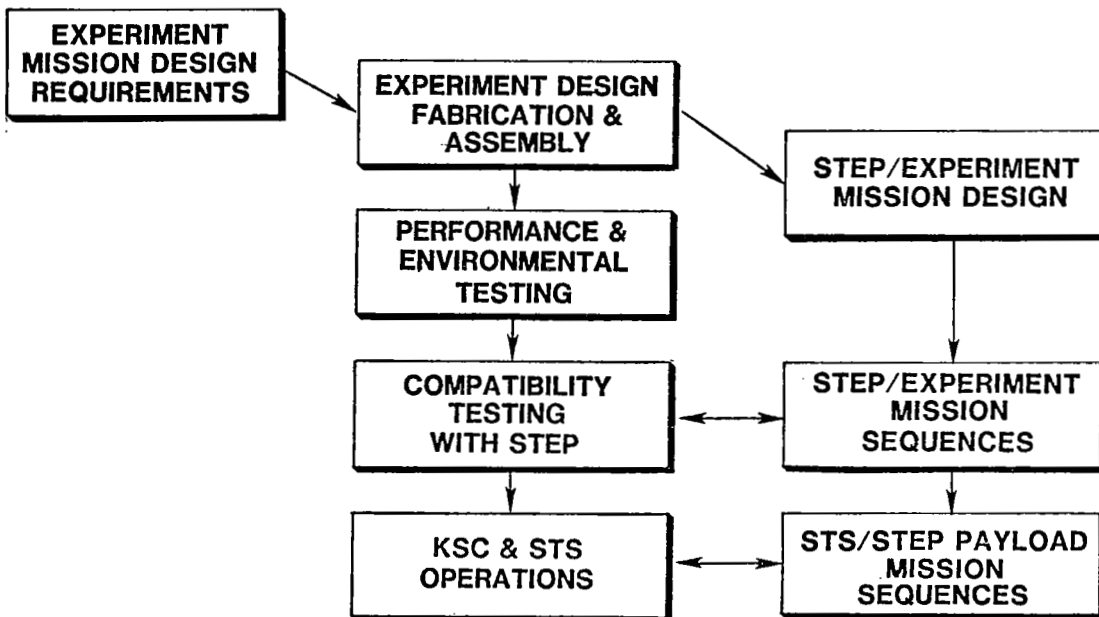

STEP/EXPERIMENT INTEGRATION
TYPICAL SCHEDULE

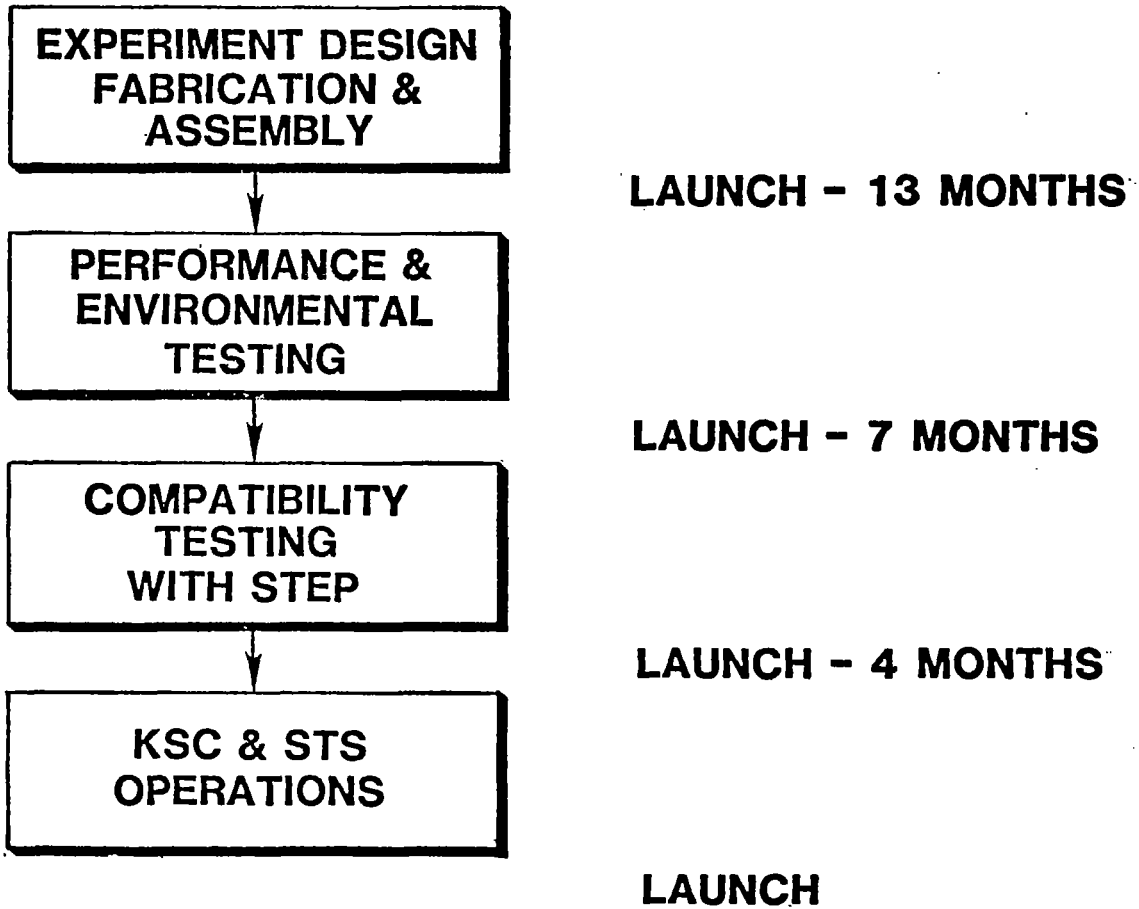

ANNOUNCEMENT OF OPPORTUNITY AND
EXPERIMENT SELECTION PLANS

Larry D. Pinson
NASA Langley Research Center
Hampton, Virginia

RESEARCH RATIONALE

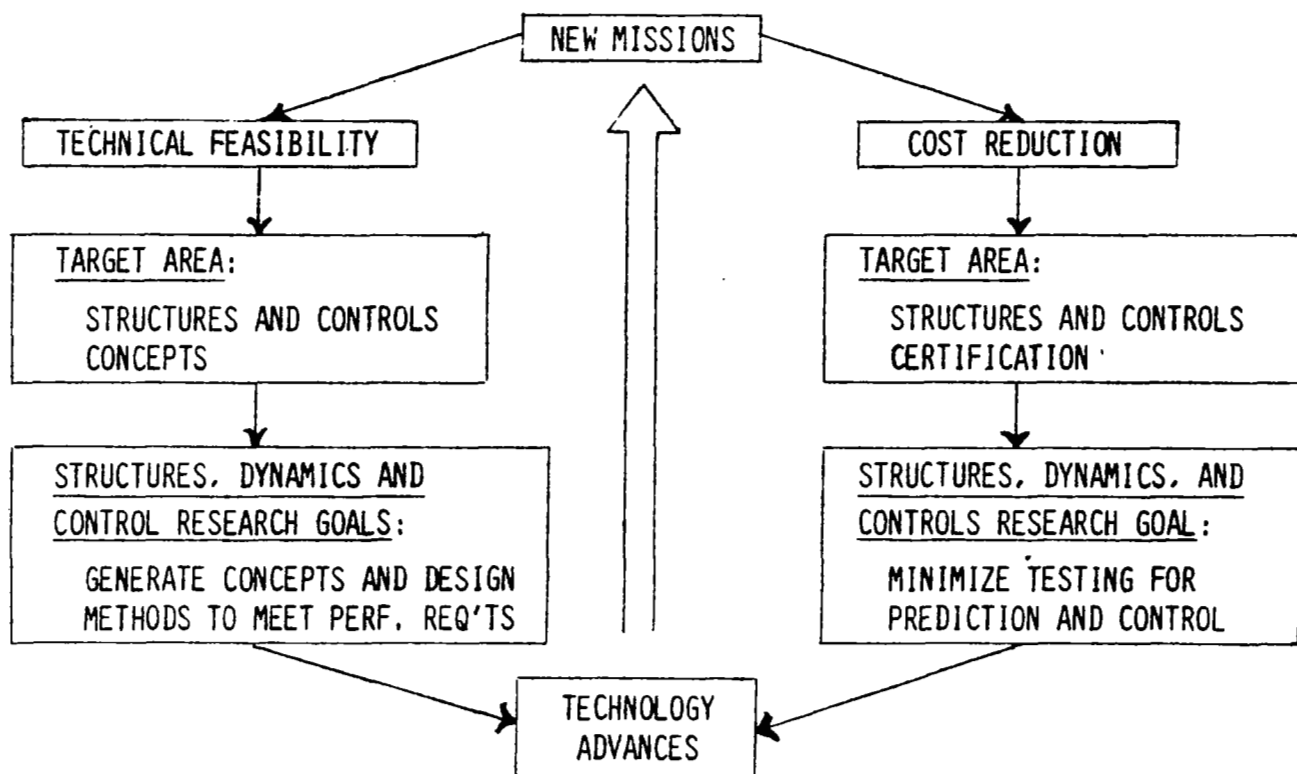

ANNOUNCEMENT OF OPPORTUNITY (AO) - TYPICAL CONTENTS

- OBJECTIVES OF ANNOUNCEMENT
- BACKGROUND
- TIMING OF PROPOSALS
- REQUIREMENTS AND CONSTRAINTS
- GUIDELINES FOR PROPOSAL PREPARATION
- PROPOSAL EVALUATION AND SELECTION PROCEDURES
- EVALUATION CRITERIA

PROBABLE APPROACH FOR EXPERIMENT SELECTION

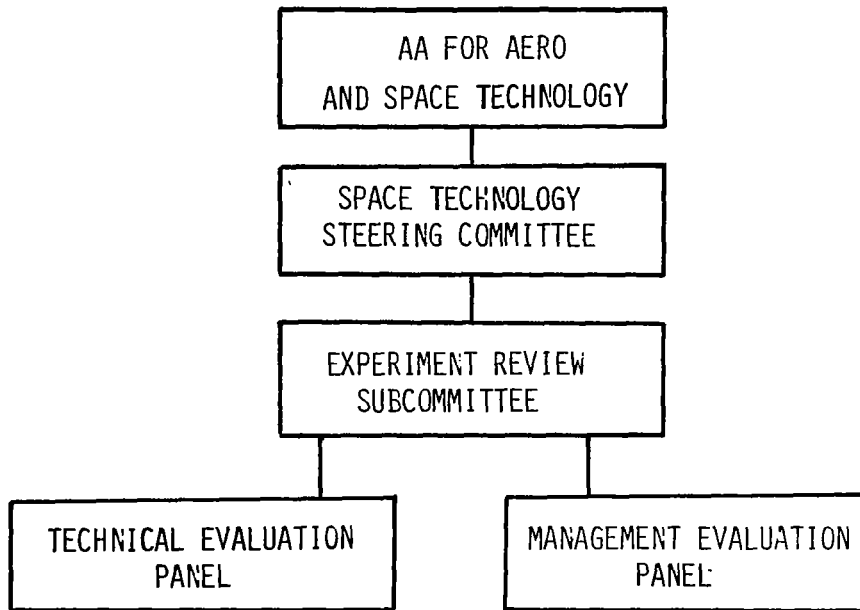

SEQUENCE OF EVENTS - PRELIMINARY

- ANNOUNCEMENT OF OPPORTUNITY 1/84
- NOTICE OF INTENT DUE 3/84
- PROPOSALS DUE 7/84
- ITERATIONS FOR CONSOLIDATION - TWO MONTHS
- EXPERIMENT SELECTION 11/84

SHUTTLE ON-ORBIT DYNAMICS

Stanley Fay
The Charles Stark Draper Laboratory. Incorporated
Cambridge, Massachusetts

\bar{a}_{exp}	vector acceleration of experiment position with respect to inertial space
\bar{a}_0	vector acceleration of body reference frame origin with respect to inertial frame of reference
(b)	denotes body frame of reference
F_j	force of vernier jet
g	gravitational unit of acceleration
(i)	denotes inertial frame of reference
J	moment of inertia about particular axis
J_x	roll moment of inertia
J_y	pitch moment of inertia
J_z	yaw moment of inertia
p_b	differentiation with respect to vehicle body frame
p_i	differentiation with respect to inertial space
R	magnitude of \bar{R}
\bar{R}	vector position of experiment in vehicle body frame with respect to body frame origin
\bar{R}_i	vector position of experiment in inertial frame with respect to inertial frame origin
\bar{R}_0	vector position of vehicle body frame origin with respect to inertial frame origin
RL	phase plane rate limit
t	time
T	period of limit cycle
T_d	disturbance torque
T_j	jet torque
u	dimensionless switch parameter for control torque ($u = +1$ signifies positive torque; $u = -1$ signifies negative torque; $u = 0$ signifies no torque)
X	angular rate of angular position
X_C	command quantity of angular rate on angular position

X_E	error quantity of angular rate or angular position
β	a mass property parameter
γ	angular velocity of composite body system, orbiter plus payload
Δt	increment of time
$\Delta\theta$	deviation of angular position from dead band setting
θ	angular position
θ_{DB}	angular position dead band limit of phase plane
θ_E	angular position error
ω_E	angular rate error
$\bar{\omega}_{ib}$	vector angular velocity of body reference frame with respect to inertial reference frame
$\dot{\omega}_{ib}$	vector angular acceleration of body frame with respect to inertial reference frame

SHUTTLE ON-ORBIT DYNAMICS

● On-orbit Dynamic Environment

- Shuttle facts
- Natural environment
 - Gravity gradient
 - Drag
 - Crew motion
- FCS closed loop
- Phase plane
- Limit cycling
- FCS modes
 - Drift
 - Universal pointing
 - Manual pulse

● On-orbit Dynamic Interaction

- Open loop, closed loop
- Generic screening
- Classes of payloads
- Causes of instability
- Vibrational spectrum
- Screening templates
- Screening parameters
- Generic screening data requirements

SHUTTLE FACTS

1. 38 Main Jets, 900 lb thrust, translation and attitude
6 Vernier Jets, 25 lb thrust, attitude only
44
- 1a. Approximate Moment Arms of Jets from center of mass (c.m.)

roll	10 ft
pitch, yaw	40 ft
2. Orbiter Angular Rates: $0.1^\circ/s$ to $5^\circ/s$
3. Attitude Dead Band: 0.1° to 5°
4. Orbiter Dimensions:

Length:	122 ft
Wing Span:	78 ft
Payload Bay:	60 ft X 15 ft
5. Orbiter Mass Approximately: $\frac{200,000 \text{ lb}}{g} = 6,500 \text{ slugs}$
6. Orbiter Moments of Inertia:

roll (forward)	$J_x \approx 1.2 \times 10^6 \text{ kg meter}^2$	=	$9 \times 10^5 \text{ ft lb s}^2$
pitch (right wing)	$J_y \approx 9.7 \times 10^6$	=	72×10^5
yaw (down)	$J_z \approx 10 \times 10^6$	=	75×10^5

ACCELERATIVE g-LEVELS AND SOURCES

SOURCE	DISTURBANCE VALUE (g)	
Gravity Gradient	8×10^{-7}	
Aerodynamic Drag	2×10^{-7}	
Flash Evaporators	2.5×10^{-7}	
Water Dump	8×10^{-6}	
Thrusters (single jet)	{ Vernier 10^{-4} g Primary 4×10^{-3} g	
Crew Motion		
Breathing	$10^{-5} - 10^{-4}$	} Frequency Band: 0.3 to 2 Hertz
Coughing	$5 \times 10^{-5} - 2 \times 10^{-4}$	
Sneezing	$2 \times 10^{-5} - 3 \times 10^{-4}$	
Console Operation	$10^{-5} - 3 \times 10^{-5}$	
Body Bending	$9 \times 10^{-5} - 3 \times 10^{-4}$	
Arm Rotation (90°)	$4 \times 10^{-5} - 2 \times 10^{-4}$	
Leg Rotation (45°)	$7 \times 10^{-5} - 2 \times 10^{-4}$	
Crouch and Stand	$3 \times 10^{-4} - 5 \times 10^{-4}$	

BASIC CONTROL LOOP

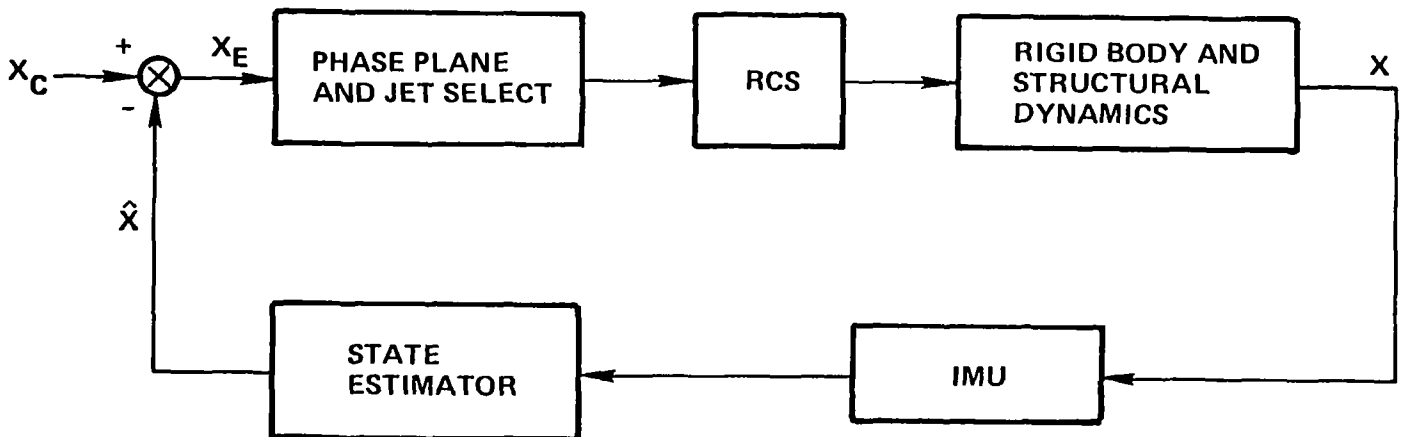

PHASE PLANE CONTROLLER

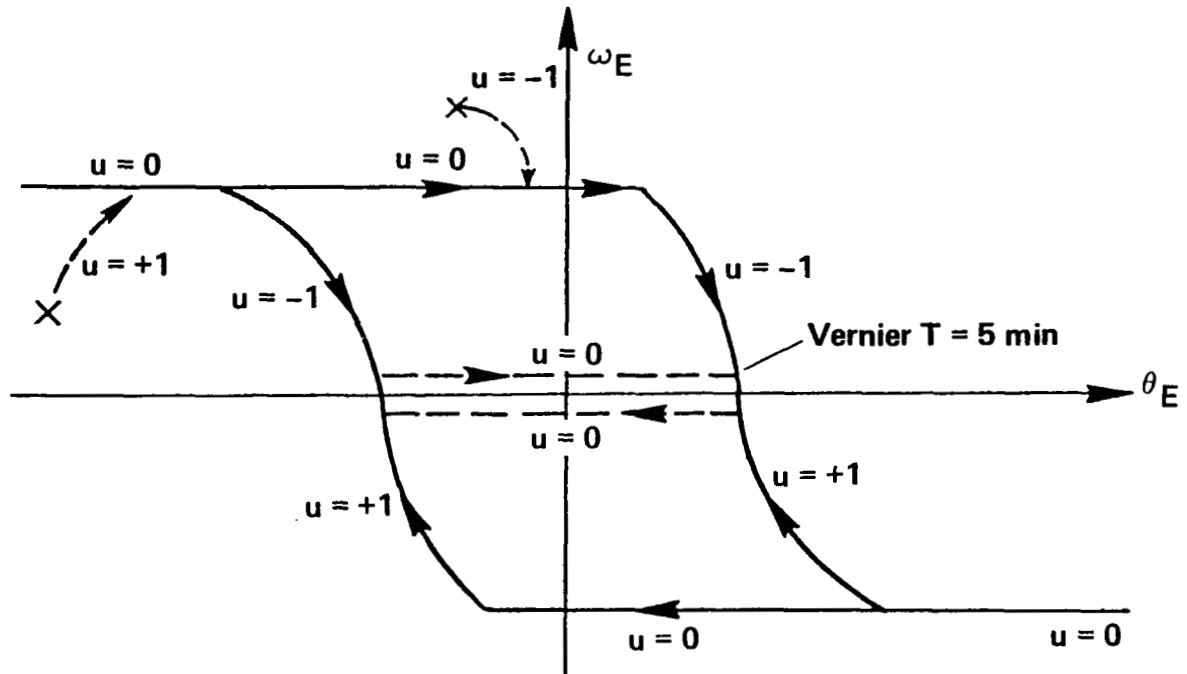

ONE SIDE OF DEAD BAND LIMIT CYCLING

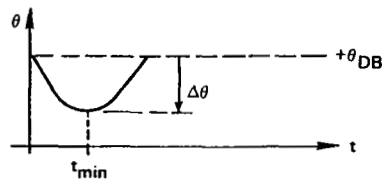

$$\text{Period of Limit Cycle, } T = \frac{T_j \Delta t}{T_d} = \frac{\text{jet impulse}}{T_d}$$

$$\Delta \theta = \frac{1}{8} \frac{(\text{jet impulse})^2}{T_d J}$$

Approximate Numerical Values:

$$F_{i_{\text{vernier}}} = 25 \text{ lb, } \Delta t = 80 \text{ ms}$$

Moment arms: roll, 10 ft
pitch, yaw, 40 ft

$$\text{roll } J_x = 9 \times 10^5 \text{ ft lb s}^2$$

$$\text{pitch } J_y = 72 \times 10^5 \text{ ft lb s}^2$$

$$\text{yaw } J_z = 75 \times 10^5 \text{ ft lb s}^2$$

YAW AXIS

	$\Delta\theta$	T_d	T
	1°	0.006 ft lb	3.7 h
	2°	0.003 ft lb	7.4 h
gravity gradient	3.4 sec	6.5 ft lb	12 s *

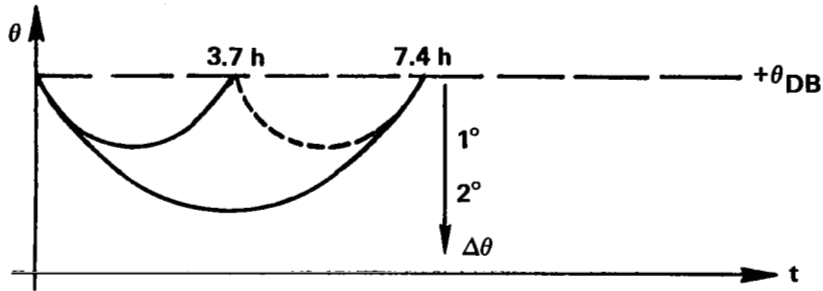

*To lengthen time between jet firings, the actual adjustment is for $1\frac{1}{2} \times$ dead band by firing more than one jet.

$$\min \theta_{DB} = 0.1^\circ$$

FCS ATTITUDE-CONTROL MODES AND TYPICAL TIMELINE

Modes

- Drift
 - Jets inhibited
 - Vehicle attitude depends solely on disturbances and initial conditions
- Universal Pointing Options
 - Inertial maneuver/hold: nonrotating reference frame
 - LVLH maneuver/hold: rotating reference frame
 - Passive thermal control: orbiter in barbecue rotation
 - Special pointing/tracking options
- Manual Pulse
 - Open-loop mode
 - Pulse initiated by hand controller; pulse duration keyed in by crew

Typical Timeline for 12 hours





FREE DRIFT IN GRAVITY GRADIENT

**STS-4, Day 2, Gravity Gradient Test
(After Venting Stopped)**

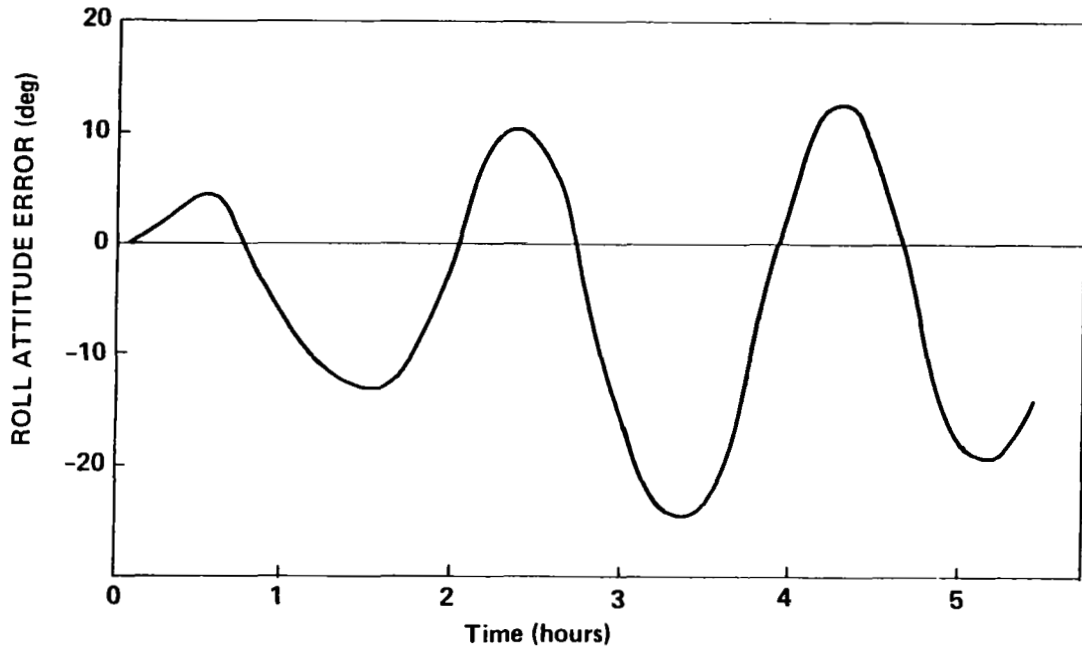

MAXIMUM AVERAGE RCS PULSING RATE

150 nmi Orbit

Inertial and LVLH Options

Jets	Mode	Dead Band (degree)	Pulse Frequency (pps)
VRCS	Inertial	0.1 to 5	0.1
VRCS	LVLH	0.1 to 5	0.05
PRCS	Inertial or LVLH	1.0	0.04
PRCS	Inertial or LVLH	5.0	0.01
PRCS	Inertial or LVLH	10.0	0.005

MAXIMUM RCS ACCELERATIONS, MANUAL PULSE MODE

<u>Rotational Acceleration (deg/s²)</u>	<u>Roll</u>	<u>Pitch</u>	<u>Yaw</u>	
VRCS	0.027	0.018	0.015	0.02 deg/s²
PRCS	0.91	1.12	0.63	1.0
	<u>(Vehicle Axes)</u>			
<u>Translational Acceleration (ft/s²)</u>	<u>X</u>	<u>Y</u>	<u>Z</u>	
VRCS	0.0002	0.006	0.007	0.005 ft/s²
PRCS (commanded translation)	0.25	0.25	1.13	0.5
PRCS (uncommanded translation)	0.06	0.13	0.25	0.1

ACCELERATION DISTURBANCES

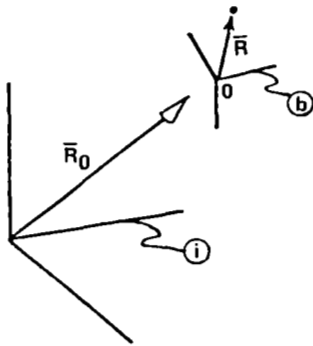

Origin of body frame at vehicle c.m.

$$\bar{R}_i = \bar{R}_0 + \bar{R}$$

$$p_i^2 \bar{R}_i = \bar{a}_0 + p_b^2 \bar{R} + 2\bar{\omega}_{ib} \times p_b \bar{R} + p_b \bar{\omega}_{ib} \times \bar{R} + \bar{\omega}_{ib} \times (\bar{\omega}_{ib} \times \bar{R})$$

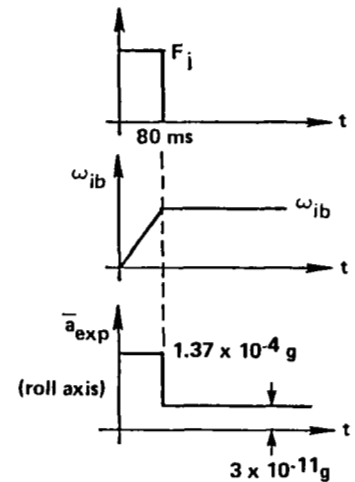

Example: Single Vernier Jet with 10-ft Moment Arm Firing One Minimum Impulse

$$\bar{a}_{exp} = \bar{a}_0 + \dot{\bar{\omega}}_{ib} \times \bar{R} + \bar{\omega}_{ib} \times (\bar{\omega}_{ib} \times \bar{R})$$

Experiment distance from c.m., $R = 2$ ft

DYNAMIC INTERACTION

- **Definition of Dynamic Interaction**
 - Open loop
 - No effect on FCS
 - Loads problem to payload
 - Closed loop
 - Instability
 - Excessive jet activity
- **Simulation Studies**
 - IUS/TDRS
 - /Galileo
 - /DoD-1
 - Space telescope reboost
 - RMS/PEP
 - RMS/DoD generic payload
 - OAST-1
- **Payload screening**
 - Generic screening
 - Simplified FCS
 - Detailed study

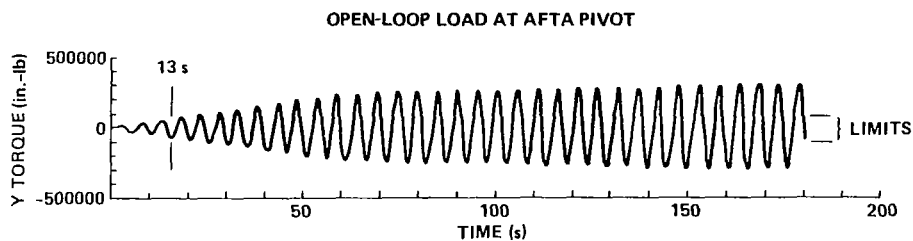

PITCH LOAD AT AFTA PIVOT, IUS/TDRS

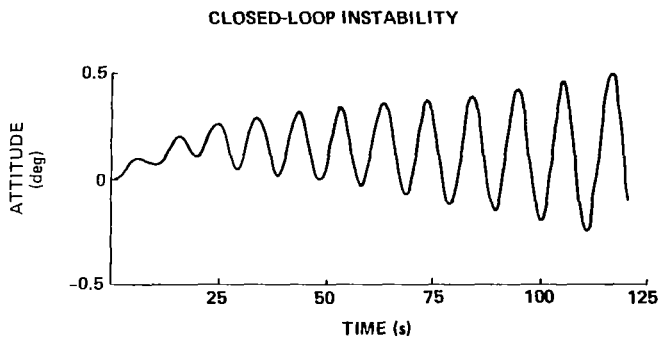

GENERIC SCREENING

● CLASSES OF PAYLOADS

I. Rotating out of bay (nonspinning)

- IUS/TDRS
- PAM-A before spin-up
- Centaur
- RMS (approx.)

II. Spinning (H-vector)

- PAM-D } during and after spin-up
- PAM-A }

III. Other

- (A) Long masts (beams)
 - OAST-1 solar array
- (B) RMS
- (C) Unique
 - SYNCOM
- (D) LSS
 - Large antenna
 - Etc.

CLASS 1 PAYLOAD ROTATED OUT OF BAY

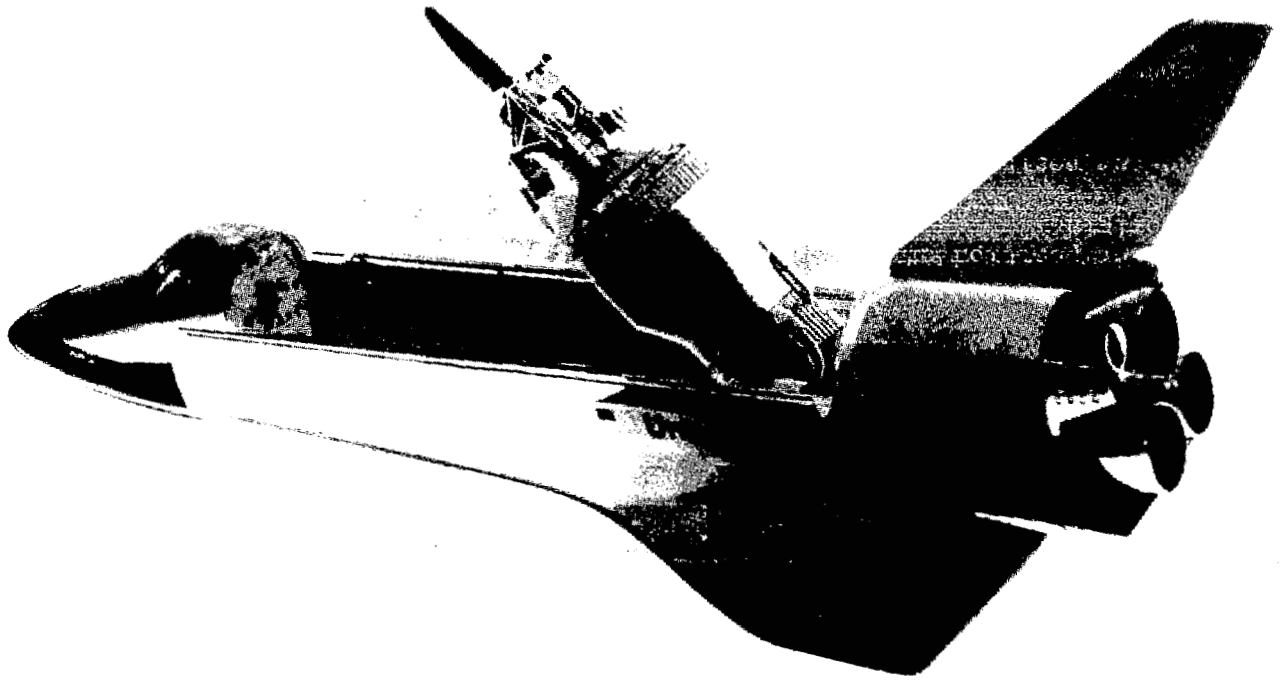

GENERIC SCREENING

- **Instability due to phase lags of**
 - **Structural system**
 - **Phase plane dead zones**
 - **State estimator**
 - **Transport lags**

SPECTRUM OF RELATIVE FREQUENCIES

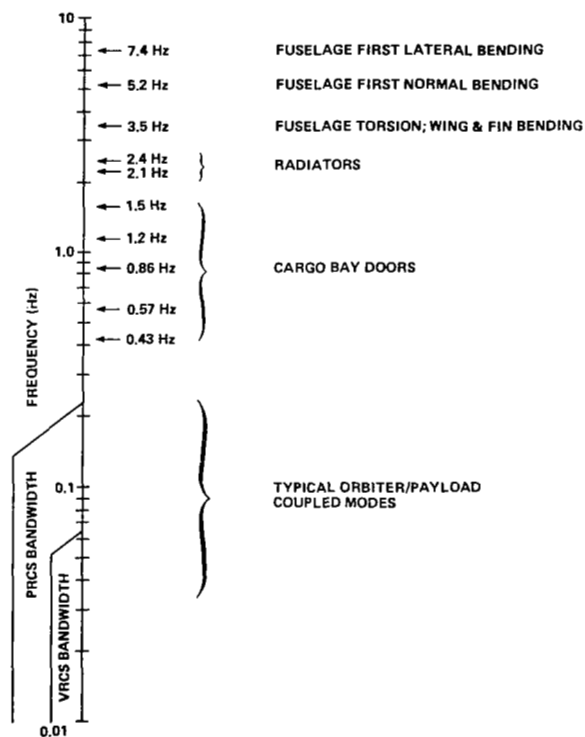

**ON-ORBIT DAP
STATE ESTIMATOR GAIN FOR ANGULAR RATE OSCILLATIONS**

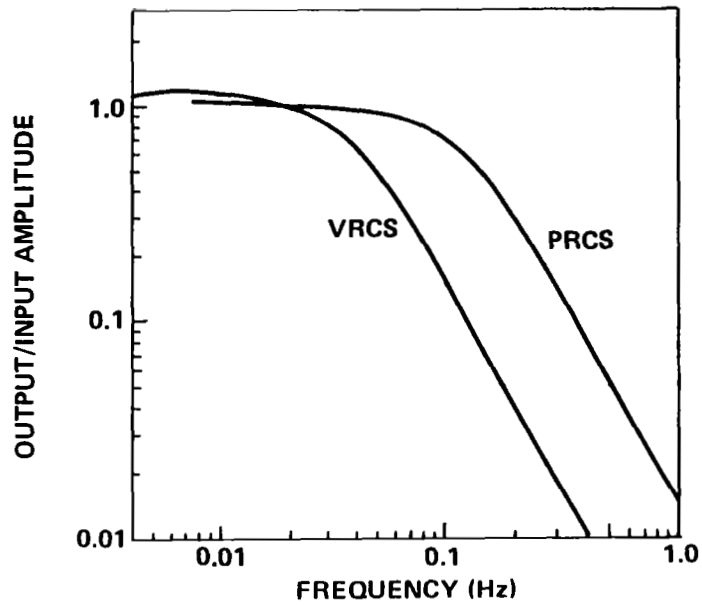

GENERIC SCREENING PARAMETERS

● **Payload parameters**

- Mass
- Moment of inertia
- Attachment frequency
- Center of mass location
- Pivot location

● **Orbiter parameters**

- Mass
- Moment of inertia
- Center of mass location
- Jet forces and locations (5 options)
- FCS dead band and rate limit (selectable)

REPRESENTATIVE GENERIC TEMPLATE

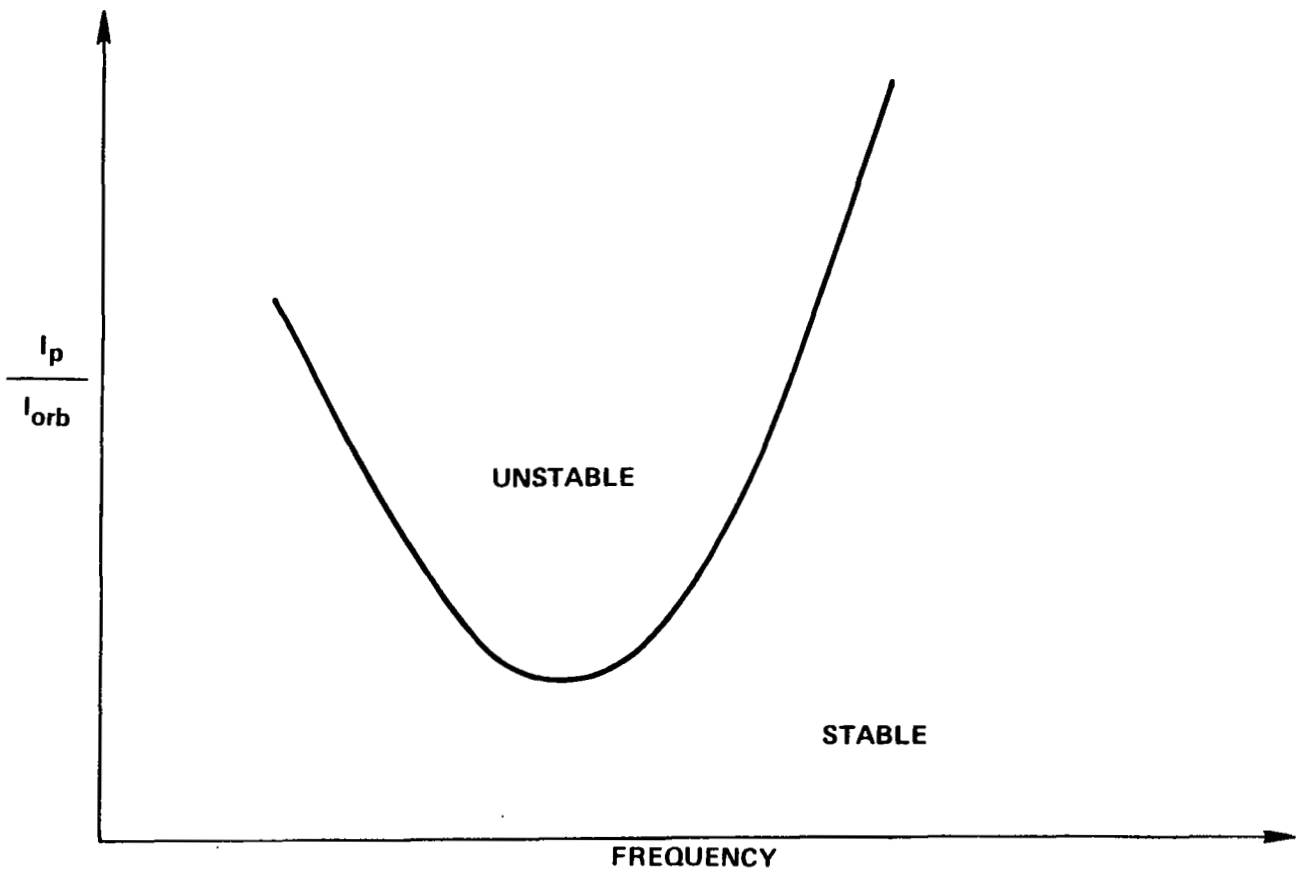

COMPUTER SIMULATION
 STABLE AND UNSTABLE REGIONS
 PRIMARY RCS CONTROL

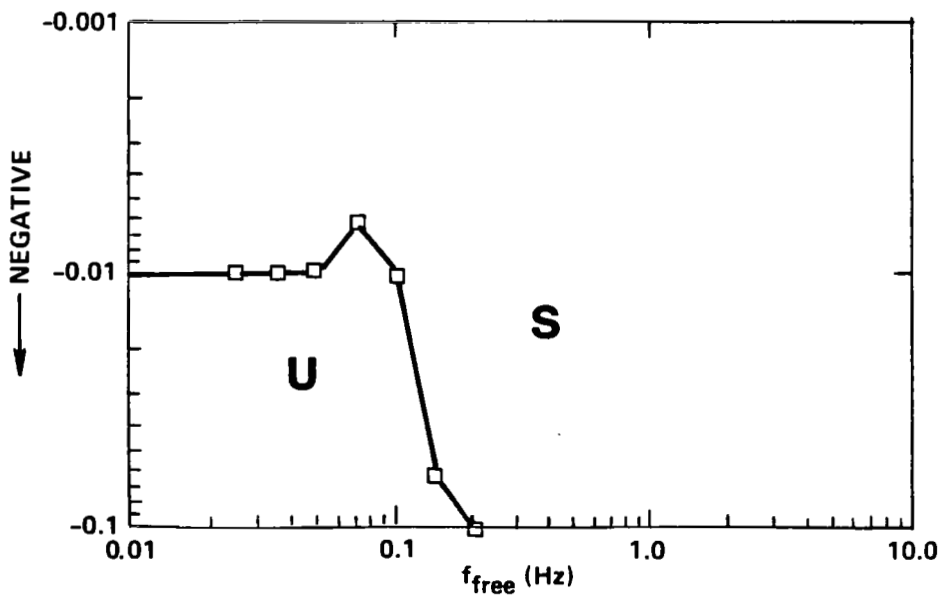
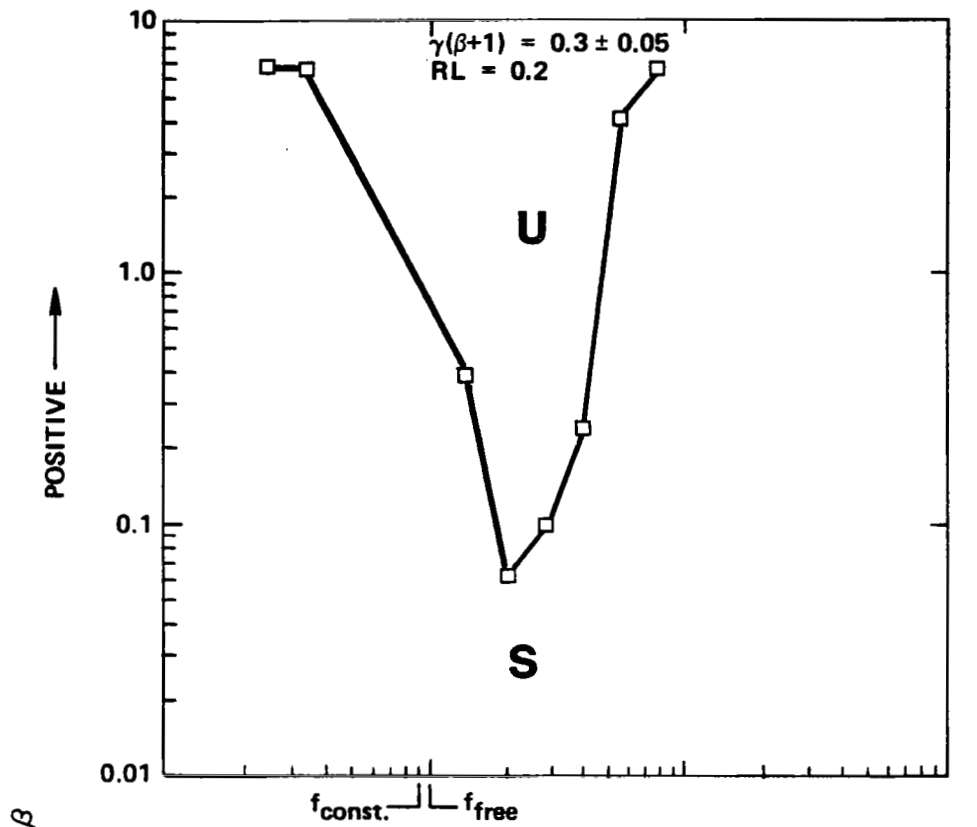

DESCRIBING-FUNCTION ANALYSIS
 STABLE AND UNSTABLE REGIONS
 PRIMARY RCS CONTROL

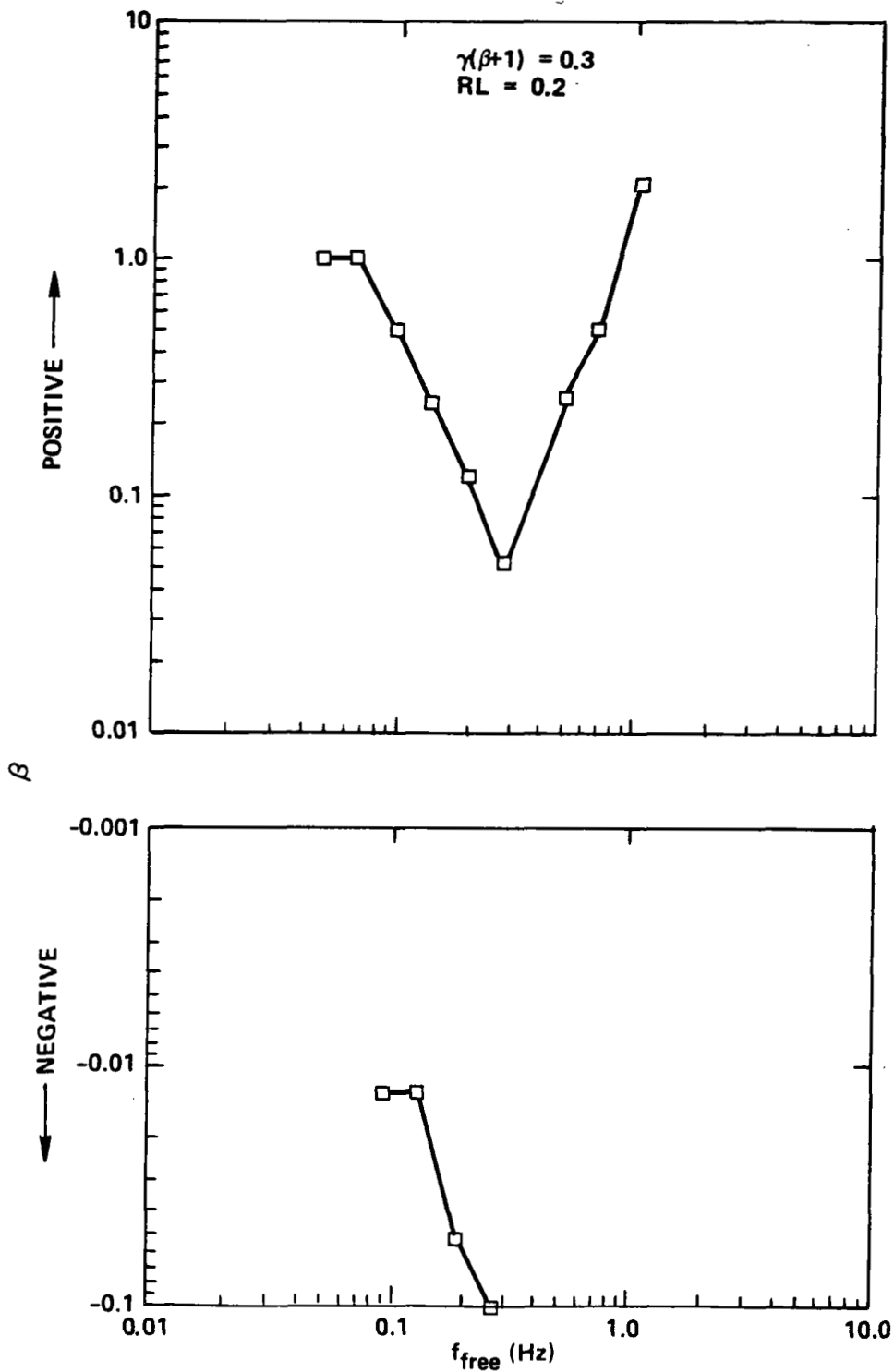

GENERIC SCREENING DATA REQUIREMENTS
FOR CLASS I PAYLOADS

Name of Payload: _____

Pivot Location: _____

Payload Data: c.m. ^{1.} _____
mass _____

moment of inertia tensor (wrt payload c.m.)^{1.}
(Use a "negative integral" definition for products of inertia.)

$$\begin{bmatrix} (&) & (&) & (&) \\ (&) & (&) & (&) \\ (&) & (&) & (&) \end{bmatrix}$$

1. In fabrication frame and therefore for all rotation angles out of bay or in a defined payload frame.

NOTE: Use fabrication frame for all locations.
Prefer slug, ft., lb. units.

Natural frequencies: Dominant first frequency mode for each axis (orbiter roll, pitch, and yaw), constrained or free (indicate)

f_{roll} _____
f_{pitch} _____
f_{yaw} _____

GENERIC SCREENING DATA REQUIREMENTS FOR CLASS I PAYLOADS - CON'T

Jet options required or excluded:

	<u>required</u>	<u>excluded</u>	<u>undecided</u>
Vernier			
Primary, aft & fwd			
aft only			
fwd only			
No + Z			

Attitude deadbands and rate limits, if known:

		<u>Nominal Values</u>	
	Vernier	Primary	
DB(deg)			Vernier Primary
			1.0 5.0
RL(deg/s)			RL(deg/s) 0.02 0.2

Orbiter Data:

c.m.² _____
 mass² _____

moment of inertia tensor².
 (wrt orbiter c.m.)

$$\begin{bmatrix} (&) & (&) \\ (&) & (&) \\ (&) & (&) \end{bmatrix}$$

Empty Orbiter:(OV99)

c.m. 93.3, -0.025, 31.175 ft.
 mass 5972.51 slugs

moment of inertia tensor
 (wrt orbiter c.m.)

$$\begin{bmatrix} (913594.0) & (620.9) & (-209855.8) \\ (620.9) & (6600138.5) & (352.7) \\ (-209855.8) & (352.7) & (6901889.6) \end{bmatrix}$$

slug ft²

2. For all mass orbiter-side of pivot including other payloads in airborne support equipment. Numbers shown are for empty orbiter.

SHUTTLE TEST ENVIRONMENT

- **All Shuttle operations must be accomplished safely with no experiment control (including reorientation)**
- **Shuttle dynamic environment provides significant disturbances and possible stability issues**
 - **High bandwidth excitation**
 - **High-level excitation**
- **Shuttle cannot provide tightly controlled stimuli**

THE EFFECTS OF THE SPACE ENVIRONMENT ON DAMPING MATERIALS
AND DAMPING DESIGNS ON FLEXIBLE STRUCTURES

Matthew F. Kluesener
University of Dayton Research Institute
Dayton, Ohio

**ADVANCED DEVELOPMENT
OF
SPACECRAFT VIBRATION
CONTROL IS BECOMING
A NECESSITY**

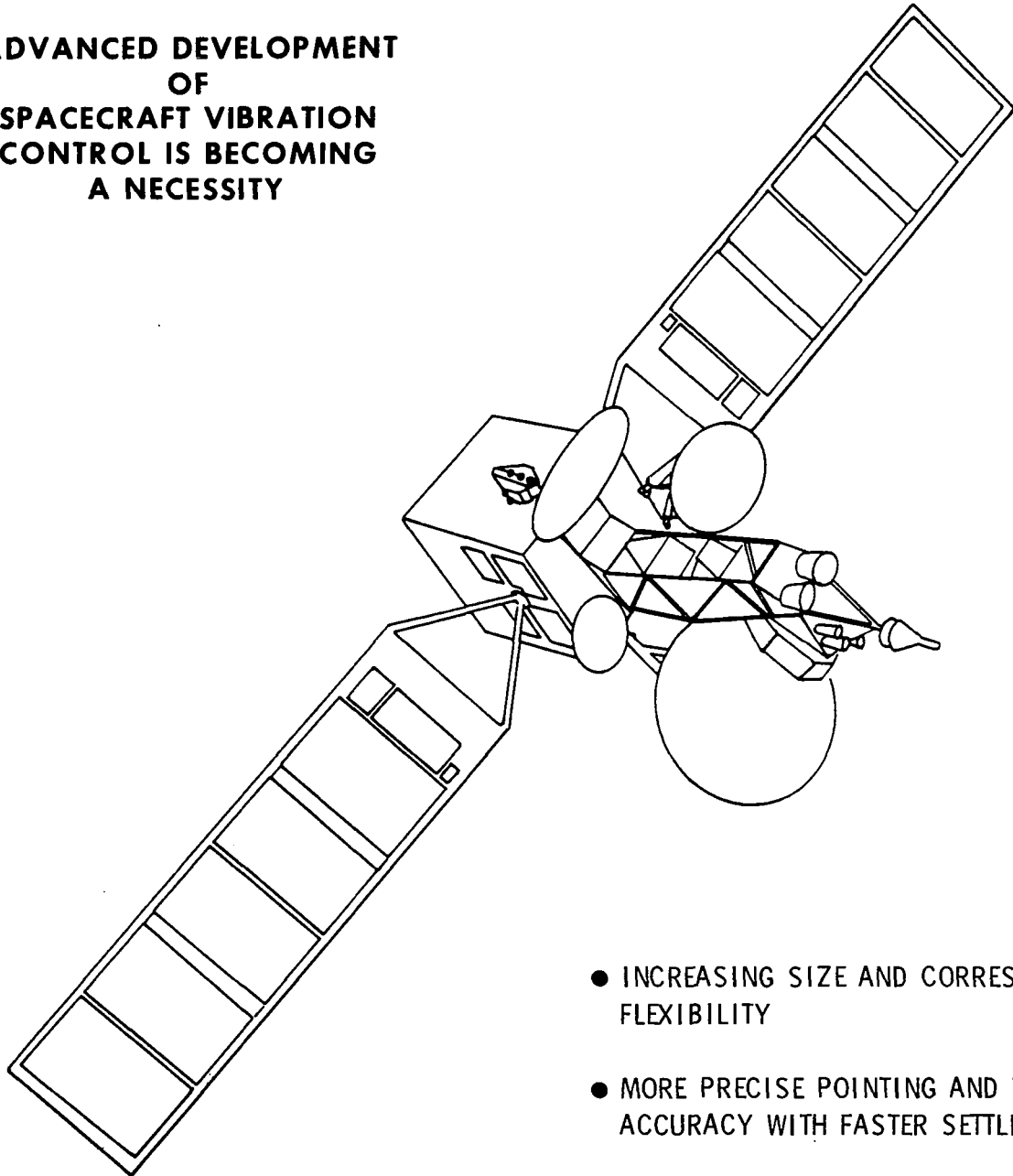

- INCREASING SIZE AND CORRESPONDING FLEXIBILITY
- MORE PRECISE POINTING AND TRACKING ACCURACY WITH FASTER SETTLING TIMES
- DIMENSIONAL TOLERANCES OF ELECTRO-OPTICAL AND ELECTROMAGNETIC SYSTEMS APPROACHING $1/50$ WAVELENGTH

PASSIVE DAMPING IS A PROMISING METHOD FOR OBTAINING
THE REQUIRED VIBRATION CONTROL

HOWEVER

- LITTLE INFORMATION IS AVAILABLE ON THE STRUCTURAL DAMPING OF REALISTIC FLEXIBLE STRUCTURES IN THE SPACE ENVIRONMENT
- LITTLE INFORMATION IS AVAILABLE ABOUT THE EFFECTS OF SPACE ENVIRONMENT ON DAMPING MATERIALS
- THE DAMPING SYSTEM MUST SURVIVE THE ENVIRONMENT

BACKGROUND

THE UNIVERSITY COMPLETED A CONTRACT WITH INTELSAT ON THE
DAMPING OF FLEXIBLE SPACECRAFT APPENDAGES

SEVERAL ITEMS WERE STUDIED

- DAMPING DESIGN FOR COMPONENTS OF FLEXIBLE STRUCTURE
- EFFECT OF VARIOUS DAMPED COMPONENTS ON SYSTEM DAMPING
- EFFECT OF VACUUM EXPOSURE ON DAMPING MATERIAL PROPERTIES

TEST ARTICLE CONFIGURATION AND OVERALL DIMENSIONS

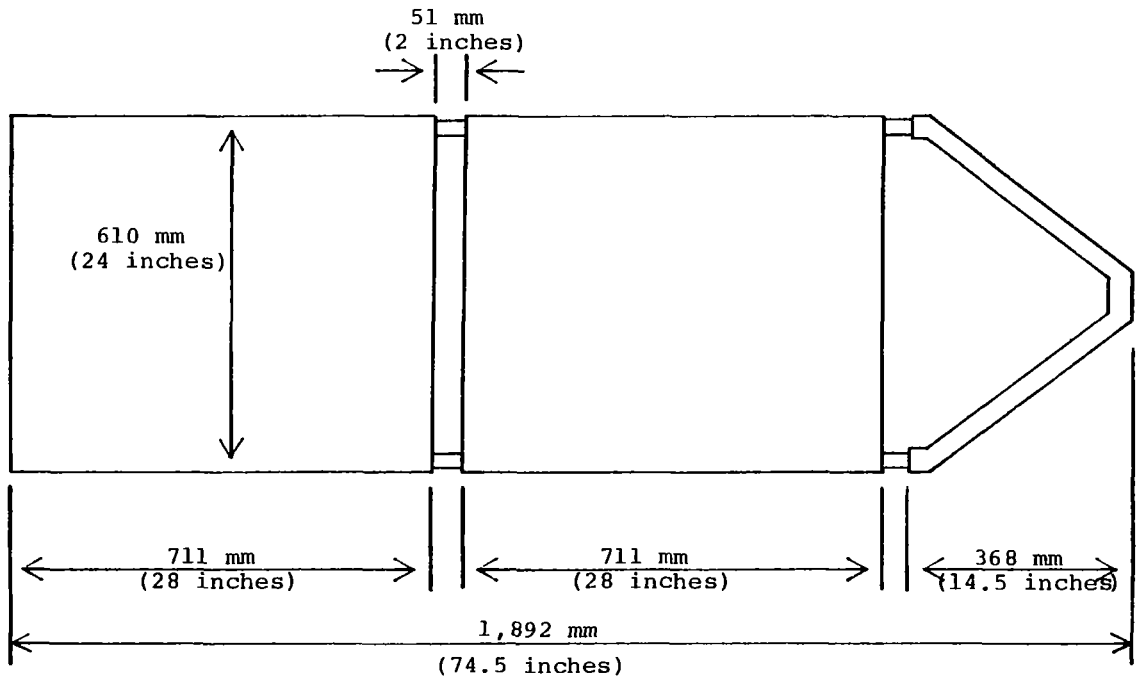

FREQUENCY RESPONSE OF DAMPED AND UNDAMPED SOLAR ARRAYS

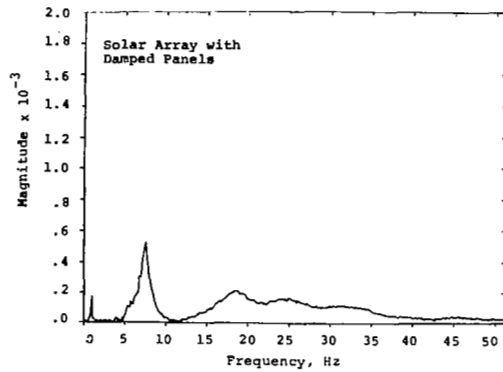
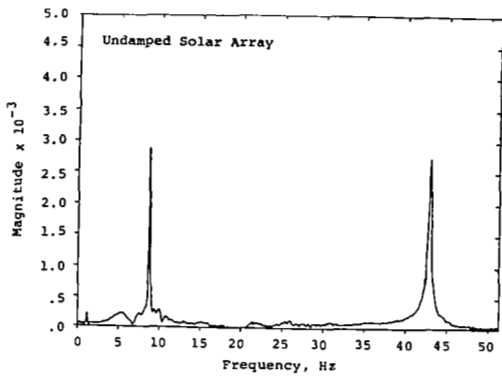

COMPOSITE LOSS FACTOR (η_s) VERSUS TIME IN HIGH VACUUM FOR DAMPED TEST BEAMS

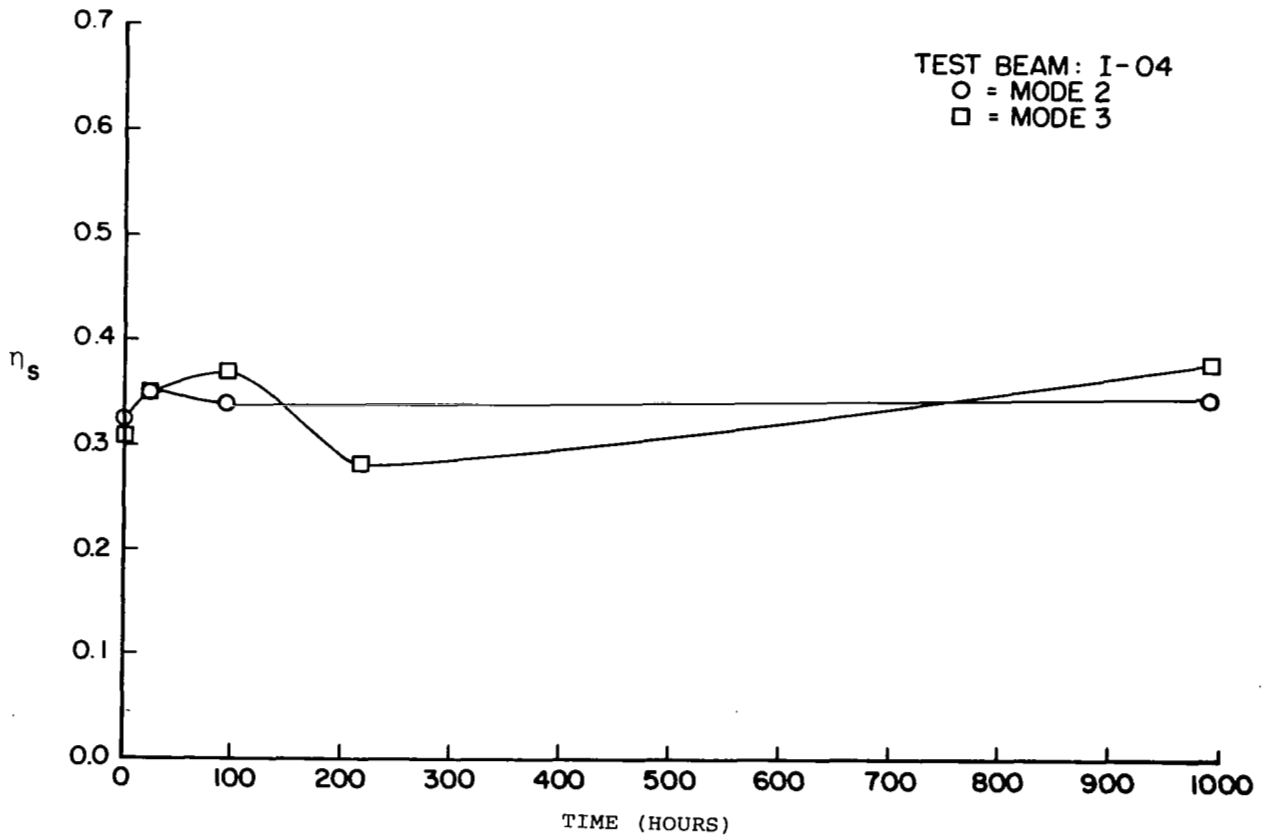

OBJECTIVES FOR STEP EXPERIMENT

- TO DETERMINE THE DAMPING IN A TYPICAL FLEXIBLE STRUCTURE IN THE SPACE ENVIRONMENT
- TO EVALUATE PASSIVE DAMPING DESIGNS ON A TYPICAL FLEXIBLE STRUCTURE IN THE SPACE ENVIRONMENT
- TO EVALUATE THE EFFECT OF THE SPACE ENVIRONMENT ON THE PROPERTIES OF DAMPING MATERIALS

SECONDARY RESULTS OF THE STEP EXPERIMENT

1. COMPARISON OF 1-G TESTS BEFORE AND AFTER THE SHUTTLE MISSION TO THE 0-G ORBIT TESTS
2. FINE TUNING OF ANALYSIS PROGRAMS FOR THE PREDICTION OF STRUCTURAL DYNAMICS IN THE SPACE ENVIRONMENT

STEP EXPERIMENT - PART 1

DAMPING OF FLEXIBLE STRUCTURES

TWO FLEXIBLE STRUCTURES (SOLAR ARRAYS)

- UNDAMPED SOLAR ARRAY
- DAMPED SOLAR ARRAY - INCLUDES PASSIVELY DAMPED COMPONENTS/JOINTS

STRUCTURE TO BE EXCITED BY IMPACT SOLENOIDS OR DEFLECTED TO AN INITIAL POSITION AND RELEASED

VIBRATION MEASURED WITH ACCELEROMETERS OR NONCONTACTING PROBES

DAMPED AND UNDAMPED MODEL SOLAR ARRAY APPENDAGES MOUNTED ON SUBSTRATE, WHICH ALSO SUPPORTS IMPACT EXCITERS

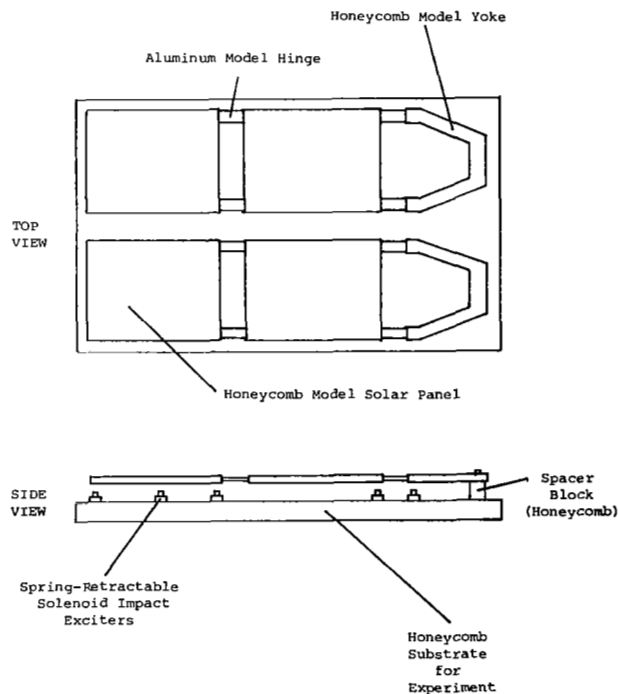

EXPERIMENT MOUNTED ON ONE-DEGREE-OF-FREEDOM ROTATION UNIT
TO PERMIT VARIOUS SOLAR EXPOSURE ANGLES

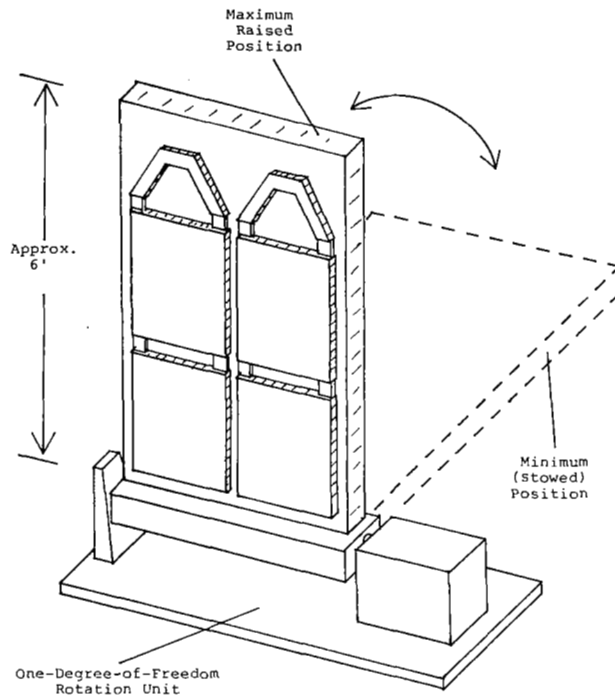

POSSIBLE LOCATIONS OF EXCITERS, ACCELERATIONS, AND
THERMOCOUPLES FOR EACH SOLAR ARRAY MODEL

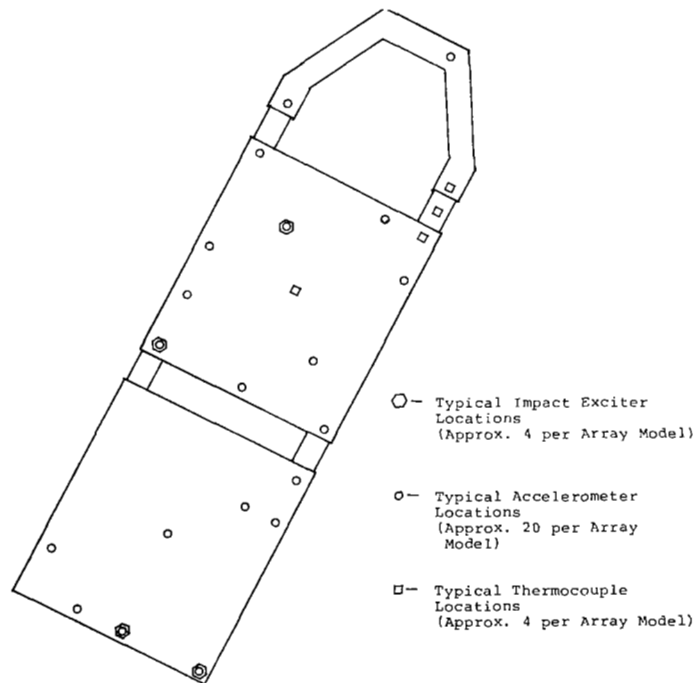

DAMPED COMPONENT FOR SOLAR ARRAY -
DAMPED BOBBIN HINGE

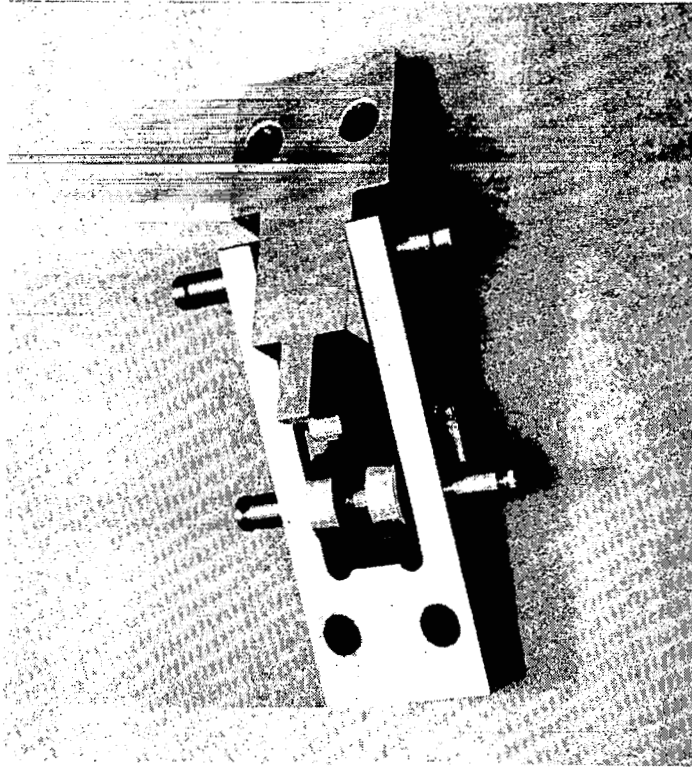

CROSS SECTION OF BOBBIN

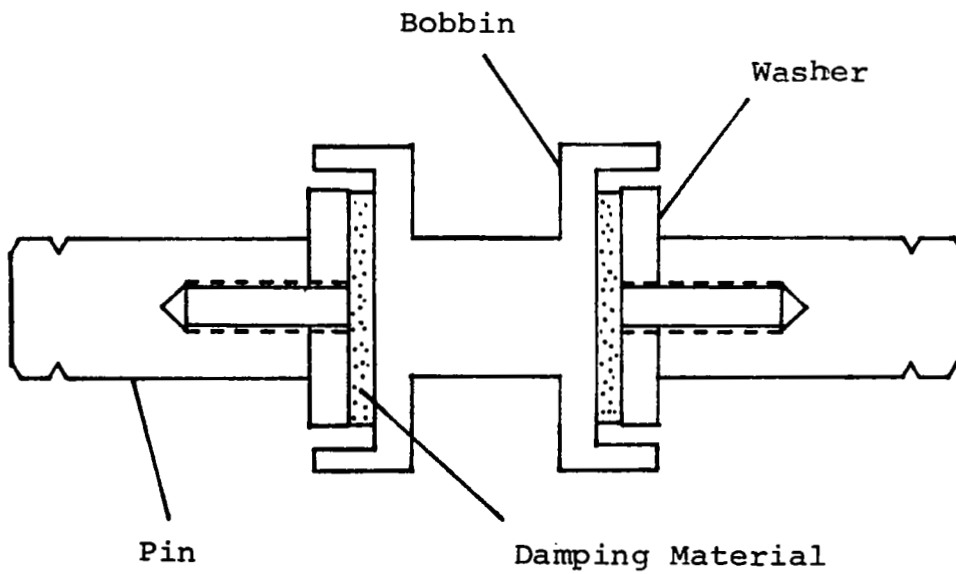

STEP EXPERIMENT - PART 2

EFFECT OF SPACE ENVIRONMENT ON DAMPING MATERIAL PROPERTIES

TESTS OF DAMPED SYMMETRIC SANDWICH CANTILEVER BEAMS (PER ASTM'S)

EXCITE BEAMS WITH IMPACT SOLENOIDS

MEASURE MODAL DAMPING WITH ACCELEROMETERS

CONSTRUCTION OF DAMPED SYMMETRIC SANDWICH BEAM

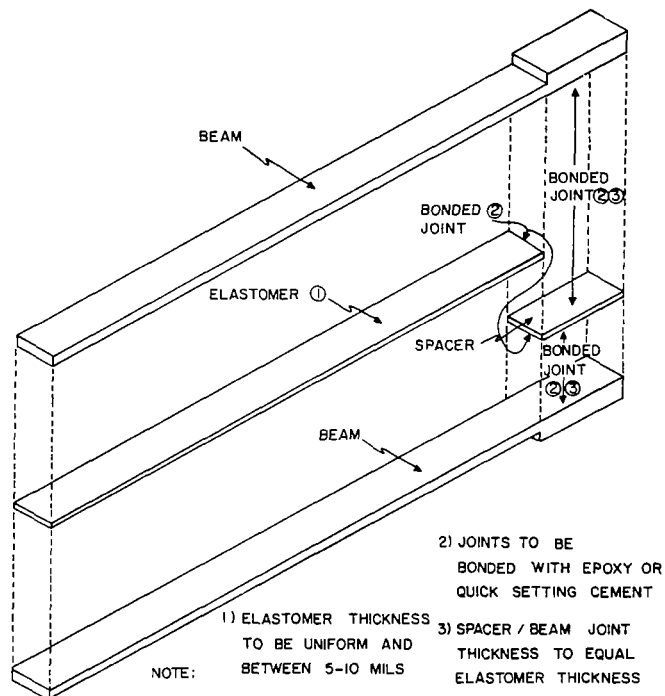

TEST FIXTURE

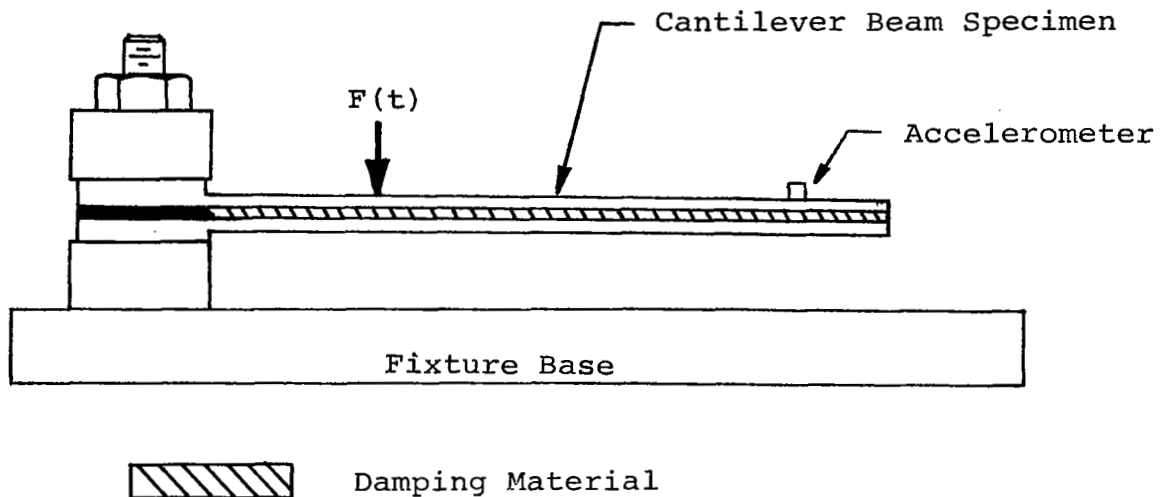

PHYSICAL & SUPPORT REQUIREMENTS (BASED ON LIMITED DEVELOPMENT)

WEIGHT \leq 100 POUNDS
INCLUDING FLEXIBLE STRUCTURES, EXCITERS,
BEAM TEST FIXTURES

ENVELOPE 6 FT X 7 FT X 7 FT
(DUE TO ROTATION OF ARRAYS)

6 FT X 3 FT X 3 FT
(STOWED POSITION)

DATA REQUIREMENTS

ANALOG OR DIGITAL STORAGE OF TEMPERATURE
AND ACCELEROMETER DATA

5 M BYTES DIGITAL

10-15 CHANNELS

GENERAL BLOCK DIAGRAM OF EXPERIMENT

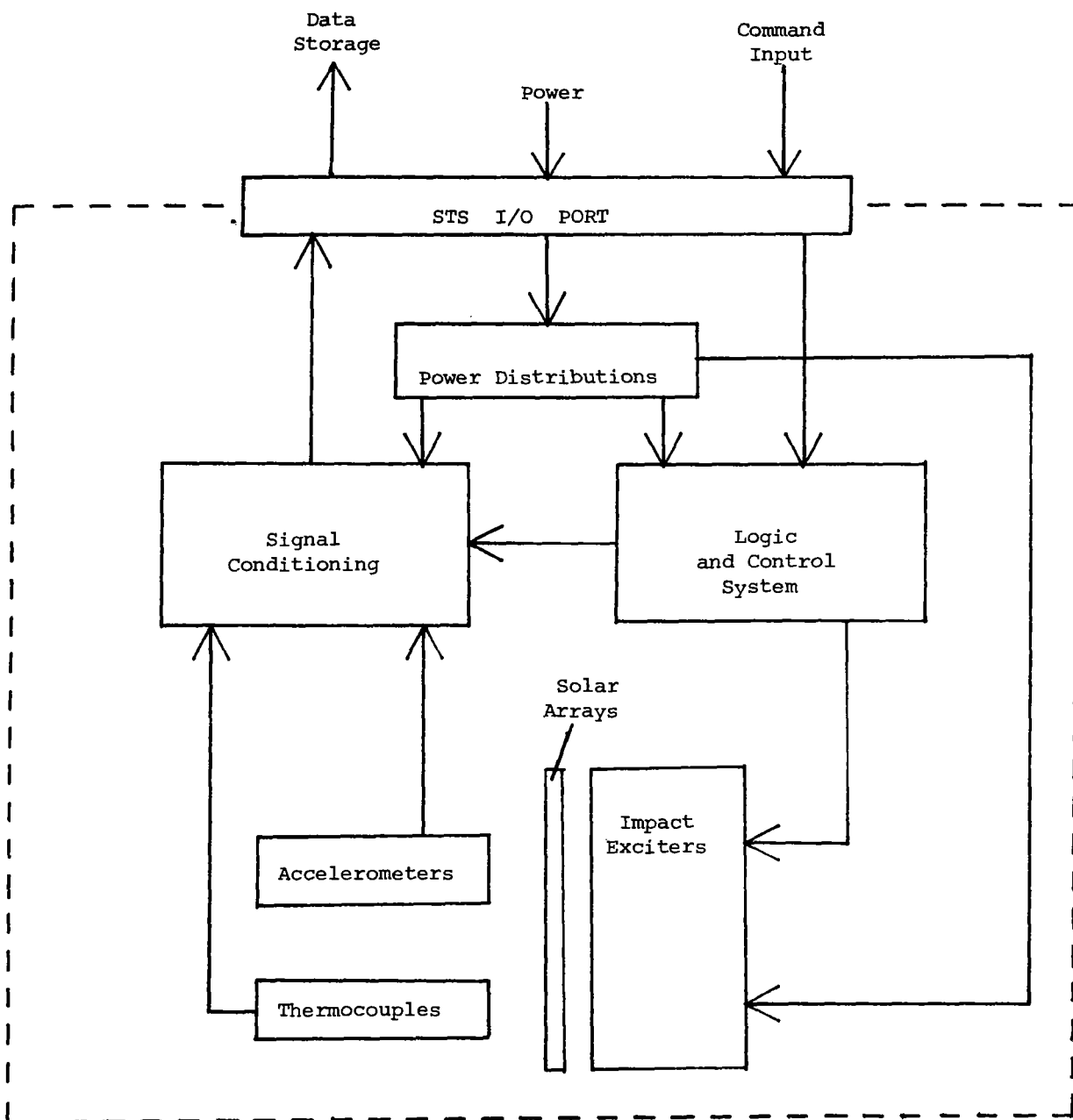

CONCLUSIONS

STEP EXPERIMENT WOULD LEAD TO INCREASED KNOWLEDGE OF:

- INHERENT DAMPING OF FLEXIBLE STRUCTURES IN SPACE
- EFFECTIVE PASSIVE DAMPING DESIGN CONFIGURATIONS FOR SPACE STRUCTURES
- EFFECT OF PASSIVELY DAMPED COMPONENTS ON THE SYSTEM LOSS FACTOR OF FLEXIBLE STRUCTURES
- EFFECT OF SPACE ENVIRONMENT ON PROPERTIES OF DAMPING MATERIALS

MEASUREMENT OF DAMPING IN
STRUCTURES IN A SPACE ENVIRONMENT

Robert Plunkett, William L. Garrard, and Bradley S. Liebst
Aerospace Engineering and Mechanics Department
University of Minnesota
Minneapolis, MN

Introduction

When writing the equations of motion of a system, damping is associated with forces which are proportional to velocities or stresses which are proportional to strain rate terms. If the system is subjected to a deformation which is periodic in time, the net mechanical work done on the system in one period is proportional to the constants of the time derivative terms. The system damping factor is a convenient dimensionless measure of damping which is defined as the ratio of the energy dissipated per period to the maximum potential energy in the system when it has a motion which is sinusoidal in time (ref. 1). This term is further divided by 2π to make it agree with some other definitions. Measurements of a great many systems have shown that for most aerospace structures this damping factor is almost independent of both frequency and amplitude at low amplitudes, and it lies in the range of 0.01 to 0.04. If the damping were actually proportional to the time derivatives, the damping factor would also be proportional to frequency; since experimental evidence shows this to be incorrect, it has become customary to represent the damping factor by structural or complex damping proportional to stiffness.

Most of the materials used in aerospace structures have damping factors of less than 0.001 so that the mechanism for the energy dissipation must be sought elsewhere. The most important mechanisms for terrestrial systems are microslip and air pumping. Energy dissipation in microslip is caused by coulomb friction between two surfaces where there is small relative motion due to elastic deformation (ref. 2). This mechanism is suppressed if the surfaces are constrained by welding or adhesives, and it is, in fact, found that welded structures have much lower damping factors than riveted or bolted ones. Air pumping causes a remarkable amount of energy dissipation due to the relative motion of extensive structures with surfaces close together as the normal distance changes due to elastic deformation (ref. 3). This damping disappears in a vacuum.

Both of these mechanisms are very dependent on the exact details of the deformation shape, and it is found that the frequency dependence changes as the shapes change. For example, for a large structure like an aircraft, the damping factor increases slowly with frequency and increasing mode number through the lower modes associated with bending and torsion of the main structural parts, the wings, and the fuselage. It will drop abruptly as the frequency associated with local plate bending modes is reached and then start to increase again as deformation associated with these modes becomes more complex. There will again be less damping associated with local bending of compressor blades and other high-frequency, compact parts. Fig. 1 shows the measured response function for a rib-stiffened plate structure (ref. 4) in which the overall bending modes are in the frequency range below 1000 Hz and the local bending modes have frequencies above that.

Our understanding of this process has been increased by experience, an experience which is not applicable to the vibration of large, flexible space structures. In addition, it is customary to assume that linear damping (in which the damping factor is independent of amplitude but does depend on frequency) ensures that superposition applies. This enables us to use modal decomposition and modal damping (ref. 5) for analysis. This assumption is clearly invalid for macroslip and coulomb friction (ref. 6) and has also been shown to be invalid for nonlinear material damping (ref. 7).

It has been known for some time that passive damping is essential for stability of large flexible space structures with active feedback control (ref. 8). Since passive damping is necessary in the frequency range where active control gain rolls

off, and since fewer controllers are needed with large passive damping, it is important to know the magnitude of this damping and its dependence on frequency. Both the magnitude and frequency dependence are a consequence of the physics of the damping mechanism and the type of vibration mode. Several damping mechanisms are affected by air pressure and g-loading; as a result, it is important to be able to measure the damping of typical space structures under high-vacuum, zero-g conditions. Any mechanism which removes energy from a defined vibration mode contributes to system damping in that mode. For that reason, it is also important that the structure being measured transmits appreciably less energy to the support structure than it dissipates internally. This is usually accomplished in terrestrial laboratories either by fastening the specimen to a rigid massive support or by supporting it with very flexible supports near points of small vibratory motion. Many space structures of interest are so flexible that they would have to be supported at many points in a one-g environment. While it might be possible to do this with air bearings, the subsequent dynamic behavior would not be truly representative of flight conditions. A zero-g environment offers the possibility of making the measurement for a nearly free-floating condition.

The damping factor is constant or increases with increasing amplitude for any physical mechanism which doesn't depend on coulomb friction with macroslip; as a result, it is only necessary to take measurements in the low-amplitude, linear region to get a reasonable estimate of the lower bound on damping.

Objective

Our objective will be to measure the small amplitude damping of typical space structures under high-vacuum and zero-g conditions. The structures used in these experiments should have characteristics typical of candidate space structures and should have easily identifiable types of modes so that the damping behavior may be correlated with postulated mechanisms. This means that the elements of the structure should be subjected to tension-compression, bending, or torsion loading for vibration in different modes at different frequencies, but, to the extent possible, there should not be combinations of these in the same mode. Some of the structures should be constructed with joints prevented from slipping by adhesives or by welding; others should use candidate slip-type fixtures in a definite pattern. In any case, the configuration should be simple enough that the type of motion is easily analyzed. It may also be possible to use the experimental setup to test candidate active feedback control system designs.

Candidate structures are:

- a) Uniform beams in bending
- b) Uniform rods in torsion with and without rotary concentrated inertia
- c) Slender trusses with rigid joints for push-pull loading with low secondary bending
- d) Vierendeel-type trusses with bending-type modes
- e) Sandwich plates
- f) Stiffened cylinders

Candidate materials are:

- a) Duralumin (low internal damping, thermoelastic damping in bending)
- b) Titanium
- c) Composites
 - i) Graphite-epoxy
 - ii) Glass-polyimide
 - iii) Graphite-aluminum
 - iv) Manganese-bronze (high-damping alloy)

Constraints

Any practical test configuration must be of reasonable size both to reduce the load to be put into orbit and to allow the test to be accommodated within the host vehicle. Scaling the details of mode shapes and damping mechanisms is very difficult and has proven unsuccessful for scale factors of more than 10 to 1 (refs. 9, 10). It seems unreasonable at this stage to contemplate testing a complete model of a very large flexible structure, and so it is proposed to test partial models that exhibit known characteristics. Some of the test structures will be full-size parts of larger prototypes. For these, the dissipation mechanism will be correct but the frequencies will be higher than in the complete structure. Other test structures will be scale models to study frequency effects, but because of the necessary modification of structural details, the dissipation mechanisms will not be correctly modeled. The testing rationale will be to understand the process; at our present state of knowledge, only tests on a full-size structure can give quantitative information about dynamic response at resonance.

For either case, the models should be designed to have natural frequencies of interest for prototypical structures. There is little point in testing at very low frequencies where the vibration will be controlled by active feedback control. There is also little point in testing at high frequencies where the controller gain is low enough that feedback instability is impossible. Subject to further study, this leads us to assume that the range from 0.5 to 50 Hz is of primary interest.

At least some of the structures must be complex enough to induce energy transfer among different types of elements so as to induce modes in which some elements have very large amplitudes while others have very low ones. One possible test structure is a large plate with periodic rib stiffeners in which some modes have large-amplitude vibration of one panel while other panels are almost quiescent (ref. 3). Properly designed, this can lead to energy loss in the higher modes of the type usually associated with statistical energy analysis (refs. 11, 12).

As mentioned above, most of the structures should be simple enough that their motion is easily analyzed and the damping mechanisms catalogued. In any case, it is important to be sure that the structure is vibrating in a single, identifiable mode for each measurement. With this constraint, the candidate measurement techniques are free decay or resonant dwell (refs. 13, 14). Since it is expected that some of the structures will have extremely small damping in some of their modes ($\eta < 0.001$) and that none of them will have very large damping ($\eta > 0.05$), free decay becomes the appropriate method. It will be essential to avoid being misled by apparent damping caused by energy transfer to other modes. This means that the test structures must be designed to have all natural frequencies in the test range separated by several times the damping bandwidth ($f_k - f_{k-1} \gg \eta f_k$). In addition, the test must be conducted by exciting one pure mode and then measuring the decay after removing the excitation. Pure mode excitation for higher, complex modes will

probably require multipoint excitation. Accurate decay measurements require that the disabled exciter does not dissipate parasitic energy.

The measurement technique should be fully automated. The system should be excited in the selected mode at its natural frequency, the excitation removed, the decay measured over an appropriate amplitude range, the data reduced, and another mode selected.

As mentioned previously, the test arrangement must be such as to reduce the energy dissipation at the supports to an amount which is negligibly small in comparison with the system energy dissipation.

Candidate Test Design

A preliminary analysis gave the following design parameters for a candidate test design.

a) There should be support fixtures with standard spacing that will maintain a floating position with low-frequency feedback supports. Magnetic or electrostatic levitation will probably do the job and have little dissipation at test frequencies. Magnetic levitation can be used with nonferrous materials by attaching magnetic shims or ceramic permanent magnets.

b) These same supports can be used to latch the test structure during transport and dissipate residual vibration energy between tests. The release system must be designed so as not to excite vibration upon release.

c) There should be multipoint excitation with phase sensitive feedback to ensure pure mode vibration exactly at resonance. Candidate methods are bilateral semiconductor strain gages (extensometers) and electromagnetic or electrostatic bilateral transducers. The feedback mechanisms used for soft supports also might be used for excitation at frequencies with periods much shorter than that of the support response time.

Fig. 2 shows a block diagram of the appropriate instrumentation and control circuitry; fig. 3 shows one concept for a preliminary design; fig. 4 shows some candidate structures.

Data Reduction

It is not necessary to store all of the time history of the vibration since the only information of interest is the damping factor and modal identification. Thus, the data should be reduced locally and only the frequency, measurement point amplitude, and relative time recorded. This latter information can be recorded digitally and only the sufficient points retained for subsequent curve fitting. Decay curves are smooth enough so that 20- to 50-digital amplitudes will give very accurate damping factors for a 100- to 1-amplitude range.

Since one of the objectives will be to extend the decay curve down to low enough amplitudes to eliminate nonlinear effects, it will be necessary to use statistically based curve-fitting techniques. At the moment, the most appealing ones are the maximum entropy or maximum likelihood methods.

Schedule

The ideal schedule would permit constructing a test fixture and associated electronics, using it on one flight with elementary structures for qualification purposes, and then reloading it on subsequent flights with increasingly complex structures. If this is not possible, some means will be developed to change test structures in flight. As mentioned before, all structures should be designed to be accommodated in the same centering fixture for intercomparison and efficient use of the data reduction system.

Physical Requirements

Overall damping of the test structures will depend very strongly on the details of how the joints are assembled. As a result, they must be fully assembled before launch. The maximum practical length is controlled by the allowable diameter of the carrier frame (2 to 3 m). This is enough to accommodate structures in the frequency range of interest (0.5 to 50 Hz). The length is of less importance, and something on the order of 1 m should be ample. The associated electronics will include signal conditioners and a dedicated microcomputer for control and data reduction; this should take little space.

It is difficult to estimate the mass of the experimental package at this time since much of it will be devoted to the support fixture. The test structures themselves will be relatively light but there may be many of them. Based primarily on the cubage and a reasonable guess as to density, we estimate an upper limit of 250 kg for the total mass of the experiment.

Support Requirements

The objective is to subject the structure to the space environment. As a result, there will be no need for power except for test excitation and data reduction. It seems unlikely that test excitation would take over 100 watts a.c. since the damping will be low. The microprocessor and data reduction system should take no more than 10 to 30 watts d.c. With the data reduction system being planned, the data storage requirements will be low enough that bubble memory or cassette storage should be adequate unless there is ample room in the main system.

If it were possible, the most efficient procedure would be to have onboard personnel interchange the test structures for each test. Once the structure is in place, the microprocessor would run through the test mode shapes and record the data. Damping levels of 0.001 and an amplitude range of 100 to 1 require a record length of about 5000 cycles per mode for decay; at 1 Hz, that is 5000 seconds or about one hour. It would take about the same length of time to excite the structure in a pure mode. Higher frequency mode shapes or higher damping would take less time. We estimate that each structure would take several hours' testing time to cover the whole frequency range of interest.

REFERENCES

1. Lazan, B. J., Damping of Materials and Members in Structural Mechanics, Pergamon Press, New York, 1968.
2. Goodman, L. E., "Material Damping and Slip Damping," Shock and Vibration Handbook, 2nd ed., C. M. Harris and C. E. Crede, eds., McGraw-Hill, New York, 1976, Chapter 36.
3. Ungar, E. E., "Damping of Panels Due to Ambient Air," Damping Applications for Vibration Control, P. J. Torvik, ed., Proceedings of the ASME Winter Annual Meeting, vol. 38, 1980, pp. 75-84.
4. Plunkett, R., "Measurement of Mechanical Impedance or Mobility," *J. Appl. Mech.*, vol. 23, no. 3, 1954, pp. 250-256.
5. Belytschko, T., and Mindle, W. L., "The Treatment of Damping in Transient Computations," Damping Applications for Vibration Control, P. J. Torvik, ed., Proceedings of the ASME Winter Annual Meeting, vol. 38, 1980, pp. 123-132.
6. Goodman, T. P., "Analysis of Two-Dimensional Motion Resisted by Coulomb Friction," *J. Eng. Ind.*, vol. 85, no. 1, Feb. 1963, pp. 17-26.
7. Plunkett, R., and Sax, M., "Nonlinear Material Damping for Nonsinusoidal Strain," *J. Appl. Mech.*, vol. 45, no. 4, Dec. 1978, pp. 883-888.
8. Stein, G., and Greene, C., "Inherent Damping, Solvability Conditions and Solutions for Structural Vibration Control," Proc. 1979 IEEE Conf. on Decision and Control, vol. 1, Dec. 1979, pp. 230-232.
9. Regiera, A. A., "The Use of Scaled Dynamic Models in Several Aerospace Vehicle Studies," Use of Models in Scaling in Shock and Vibration, W. E. Baker, ed., ASME, New York, 1963, pp. 34-50.
10. Beavers, G. S., and Plunkett, R., "Modeling of Flow-Induced Vibrations in Heat Exchangers and Nuclear Reactors," *J. Fluids Eng.*, vol. 69, series I, no. 4, Dec. 1974, pp. 358-364.
11. Ungar, E. E., "Statistical Energy Analysis of Vibrating Systems," *J. Eng. Ind.*, vol. 89, series B, no. 4, Nov. 1967, pp. 626-632.
12. Lyon, R. H., and Maidenik, G., "Power Flow Between Linearly Coupled Oscillators," *J. Acoust. Soc. Am.*, vol. 34, no. 5, May 1962, pp. 623-639.
13. Plunkett, R., "Measurement of Damping," Structural Damping, J. E. Ruzicka, ed., Proceedings of the ASME Colloquium, 1959, pp. 117-131.
14. Chu, F. C., and Wang, B. P., "Experimental Determination of Damping in Materials and Structures," Damping Applications for Vibration Control, P. Torvik, ed., Proceedings of the ASME Winter Annual Meeting, vol. 38, 1980, pp. 113-122.

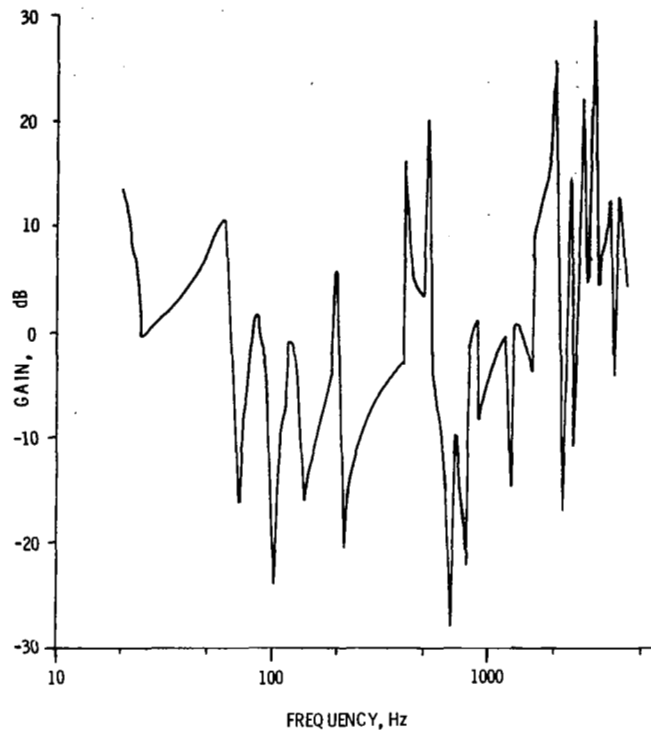

Figure 1.- Measured response function of rib-stiffened plate structure.

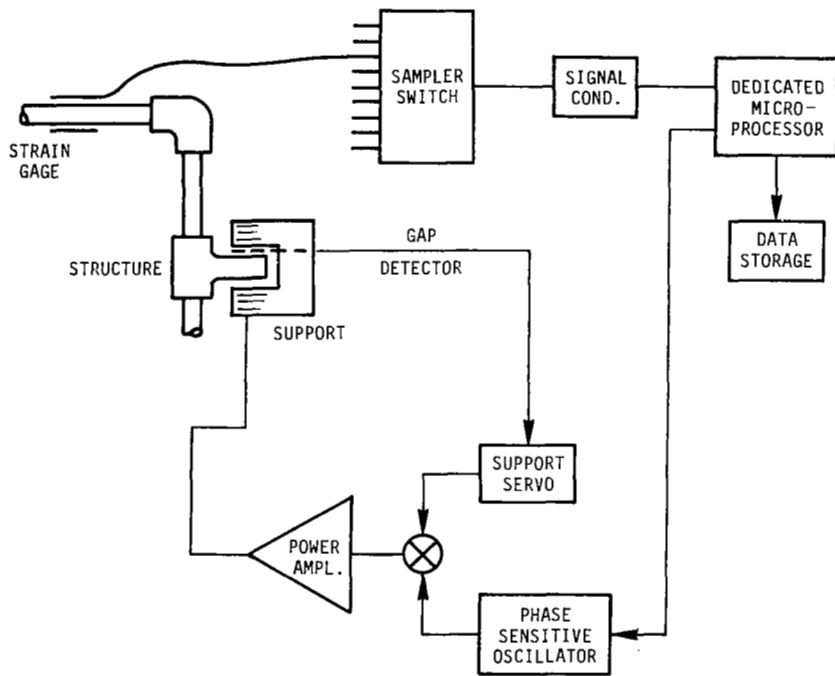

Figure 2.- Block diagram of instrumentation and control circuitry.

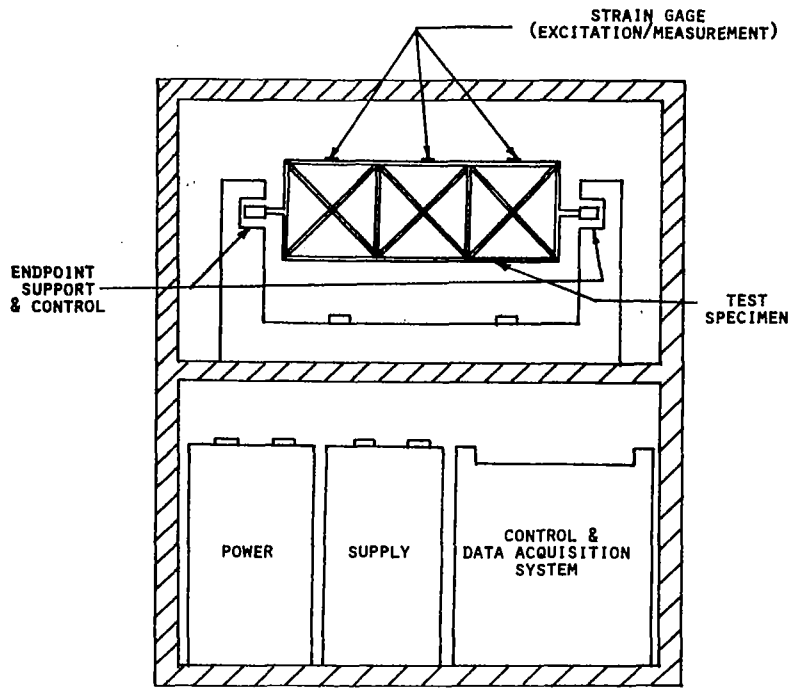

Figure 3.- Candidate experiment configuration.

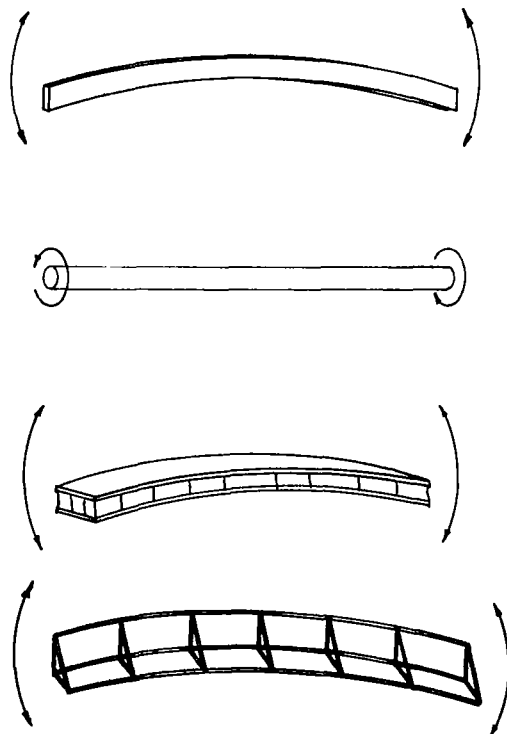

Figure 4.- Candidate test structure.

DEPLOYABLE BEAM FLIGHT EXPERIMENT (MAST)

Brantley R. Hanks and John L. Allen, Jr.
NASA Langley Research Center
Hampton, Virginia

FUTURE LARGE SPACE SYSTEMS

Future space systems such as large antennas or a space station may have dimensions on the order of 30 m to 200 m, yet their basic structures may be relatively lightweight and flexible, making ground tests for loads, controls analyses, and design verifications questionable if not impossible. Abandoning the extensive ground test and analysis verification program that led to the success of previous spacecraft is not a sensible option; making it meaningful using current technology will require inefficient, ultraconservative structure and control designs. The alternative is to improve the technology. (See fig. 1.)

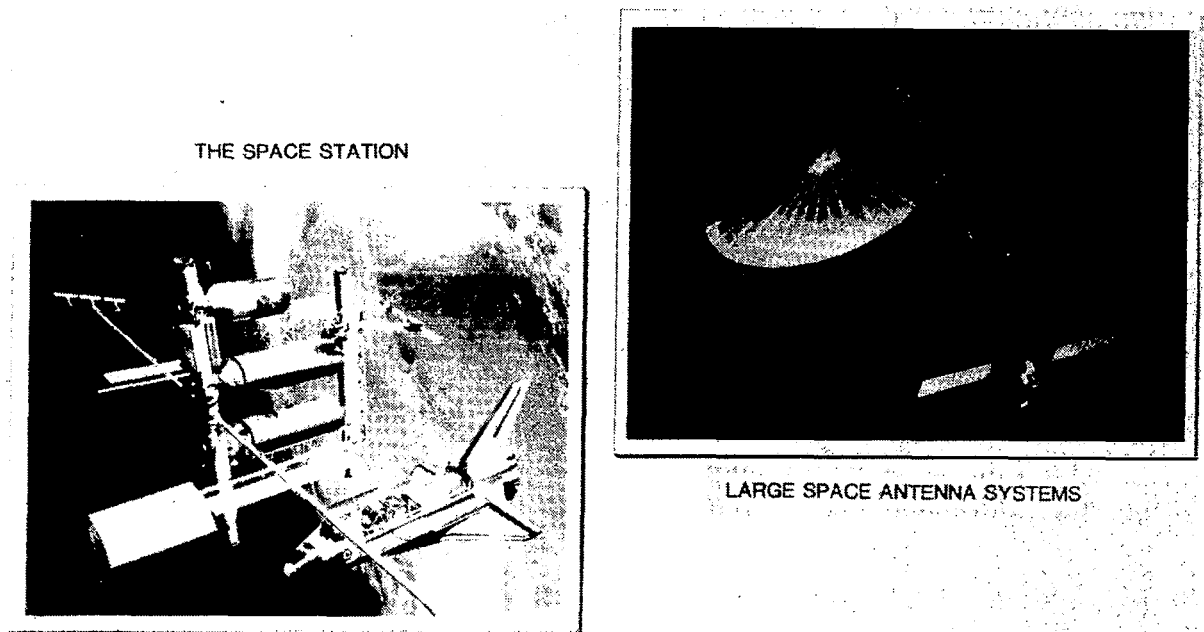

Figure 1

WHY ORBITAL TESTS?

The five reasons listed here are strong incentives to conduct orbital "laboratory experiments" in order to assure adequate understanding of technical problems before committing expensive major large space systems to orbit. A coordinated program of ground tests, analyses, and flight tests on a practical structure that is reasonably well understood is needed to study phenomena and to calibrate the design/test process. (See fig. 2.)

- o ACCURATE STRUCTURAL MODELS NEEDED FOR CONTROL DESIGN
- o GROUND TESTS POOR ON LOW-FREQUENCY, LIGHTWEIGHT STRUCTURES
- o DEPLOYMENT & CONTROL FORCES AT PRACTICAL LEVELS
- o MULTI-DEGREE-OF-FREEDOM COUPLED MOTION ACCURATELY SIMULATED
- o COMBINED THERMAL/VACUUM/ZERO-G EFFECTS ON JOINTS & MEMBERS

COORDINATED GROUND TEST, ANALYSIS, FLIGHT TEST PROGRAM ON A "PREDICTABLE" JOINT-DOMINATED, NEXT-GENERATION SPACE STRUCTURE WILL PROVIDE CRITICAL INFORMATION FOR PRACTICAL HARDWARE DESIGN AT REDUCED RISK. EMPHASIS ON TECHNOLOGY & INFORMATION GATHERING AS OPPOSED TO HARDWARE IS IMPORTANT.

Figure 2

ARTIST'S CONCEPTION OF A SHUTTLE-ORBITER-ATTACHED
TRUSS BEAM FOR ORBITAL SPACE TESTS

A relatively simple cantilevered truss beam deployed from the Shuttle orbiter payload bay is an excellent candidate for the needed studies. In addition, a useful by-product (a space-qualified, next-generation truss beam applicable to the antenna and space station of figure 1) would be produced. (See fig. 3.)

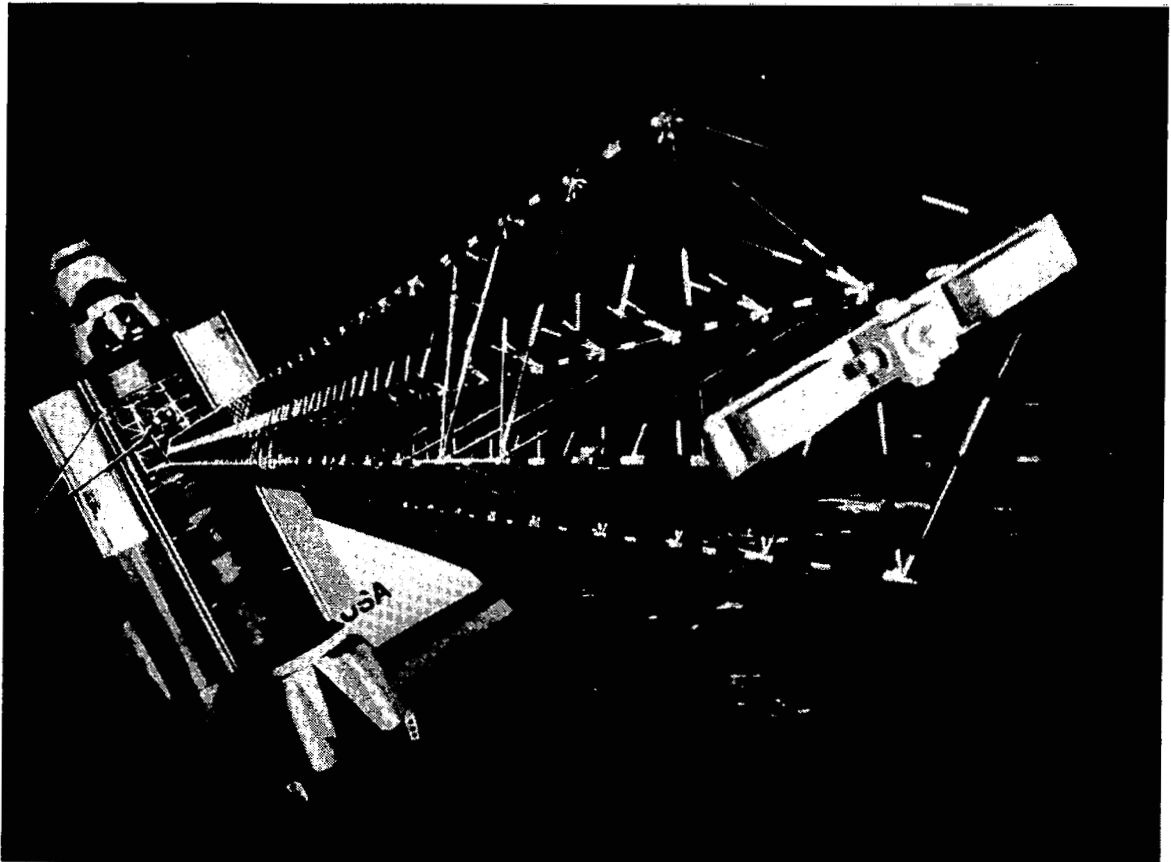

Figure 3

DEPLOYABLE BEAM EXPERIMENTS

A program (hereinafter referred to as Mast) using such a deployable beam to research solutions for the problems discussed in figure 2 is briefly overviewed here. (See fig. 4.)

OBJECTIVE:

DEVELOP STRUCTURES, STRUCTURAL DYNAMICS, AND CONTROLS TECHNOLOGY FOR LARGE JOINT-DOMINATED SPACE STRUCTURES WHICH CANNOT BE ASSESSED ACCURATELY IN NONORBITAL ENVIRONMENT.

TECHNICAL APPROACH:

CONDUCT STEP-ATTACHED TESTS ON WELL-INSTRUMENTED DEPLOYABLE BEAM. EXPERIMENT SUPPORTS COMPREHENSIVE GROUND TEST AND ANALYSIS RESEARCH USING COMPONENTS, SUBASSEMBLIES, AND TOTAL ASSEMBLY. MINOR-RETROFIT REFLIGHTS INCREASE IN TECHNICAL COMPLEXITY FROM STATIC/DYNAMIC BEHAVIOR TO MULTIVARIABLE CONTROL-STRUCTURE INTERACTION.

JUSTIFICATION:

ABILITY TO PREDICT STRUCTURAL BEHAVIOR, CONFIGURATION ACCURACY, CONTROL, AND DEPLOYMENT FOR LARGE SPACE STRUCTURES INVOLVES INTERDISCIPLINARY INFORMATION WHICH IS HARDWARE CRITICAL. GRAVITY HAS OVERRIDING DETRIMENTAL EFFECTS ON HARDWARE BEHAVIOR AND PREDICTABILITY.

Figure 4

MAST DESIGN CONSIDERATIONS

Designing an experiment that quantifies the expected problems of large space structures involves multidisciplinary trade-offs. A beam design is needed which approaches, but does not exceed, the low-frequency limits of Shuttle payloads, ground test capabilities, and existing space-applicable sensors. (See fig. 5.)

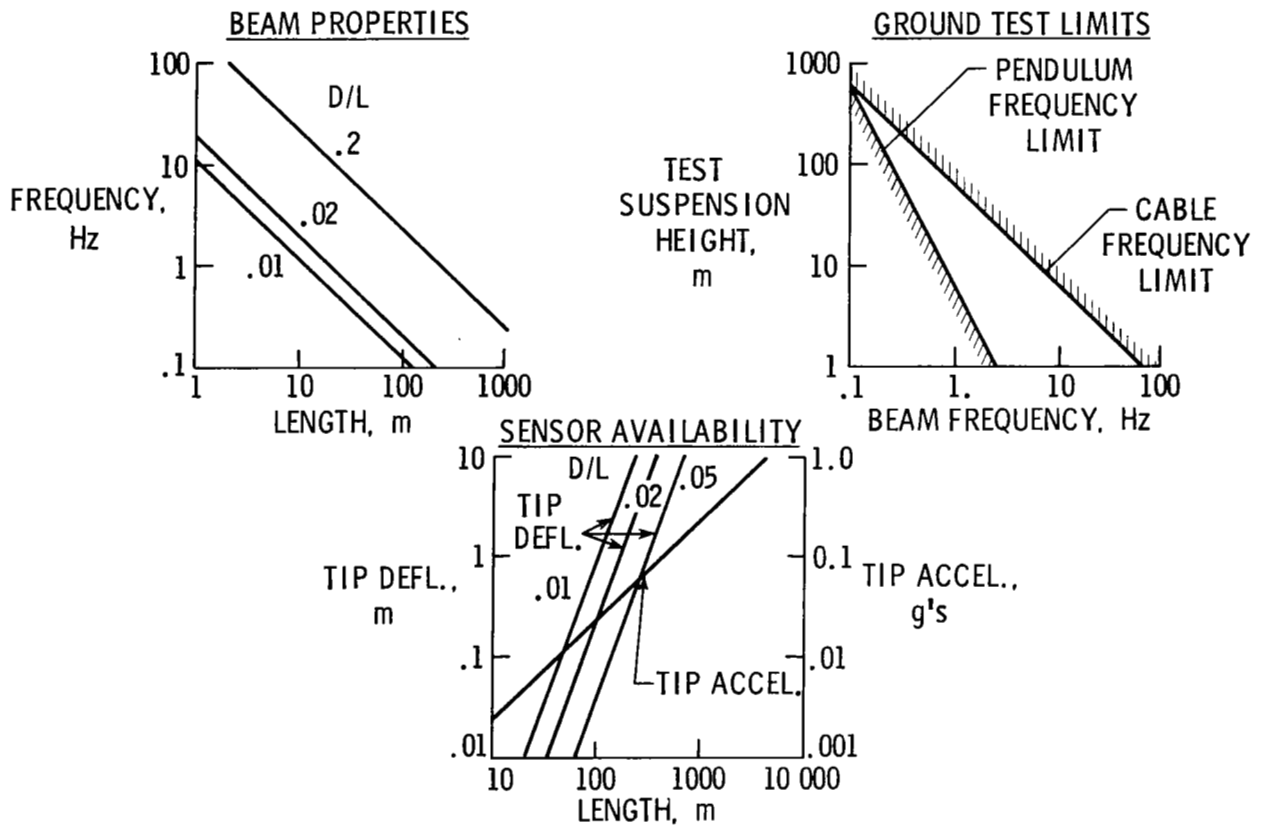

Figure 5

SPACE BEAM STIFFNESS REQUIREMENTS

In order to produce a useful beam design as an experiment by-product, expected needs of future spacecraft must also be considered. An experimental beam should be sized beyond the practical limits of state-of-the-art coilable longeron beams but within the range of projected needs. (See fig. 6.)

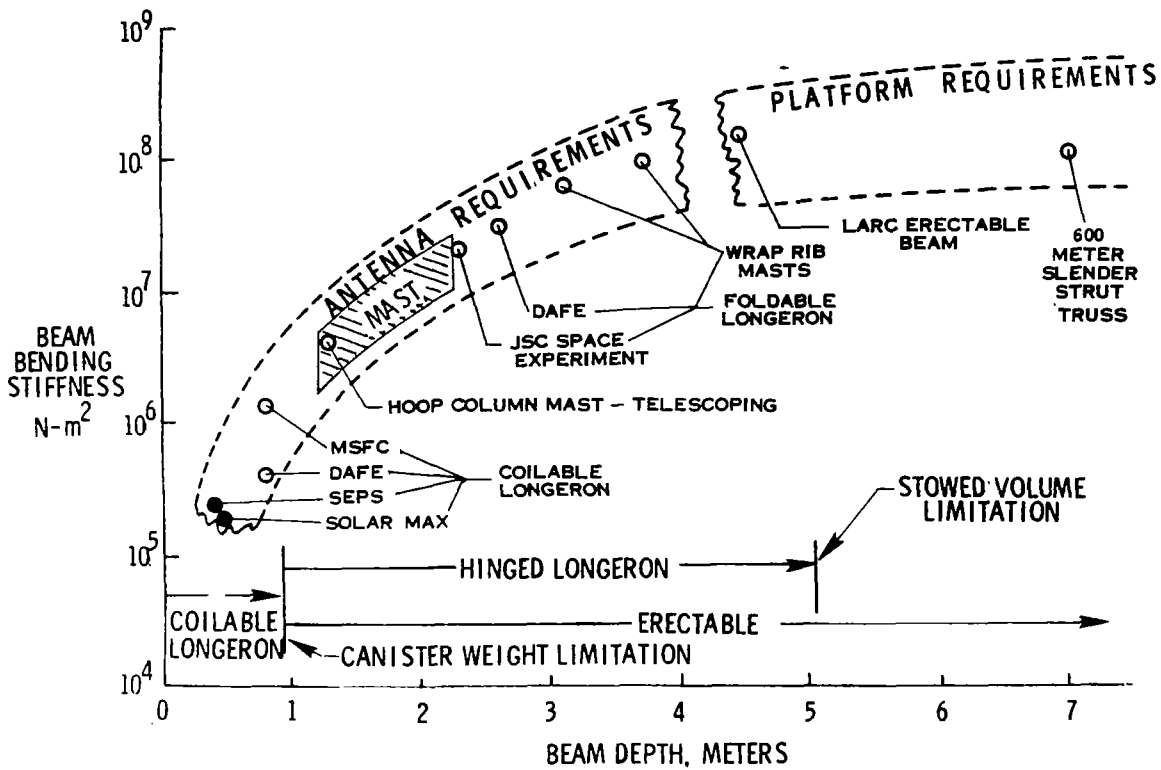

Figure 6

PRELIMINARY MAST CONFIGURATION

A preliminary beam design based on the previously shown considerations is detailed here. Its size relative to a 2-m-tall man is indicated on the left. On the right, the ability to tilt a portion of the beam through a variable angle provides coupled modes with closely spaced natural frequencies. Varying the tilt angle from zero allows calibration of analysis and system identification methods in both analytically simple and difficult situations for comparison. (See Fig. 7.)

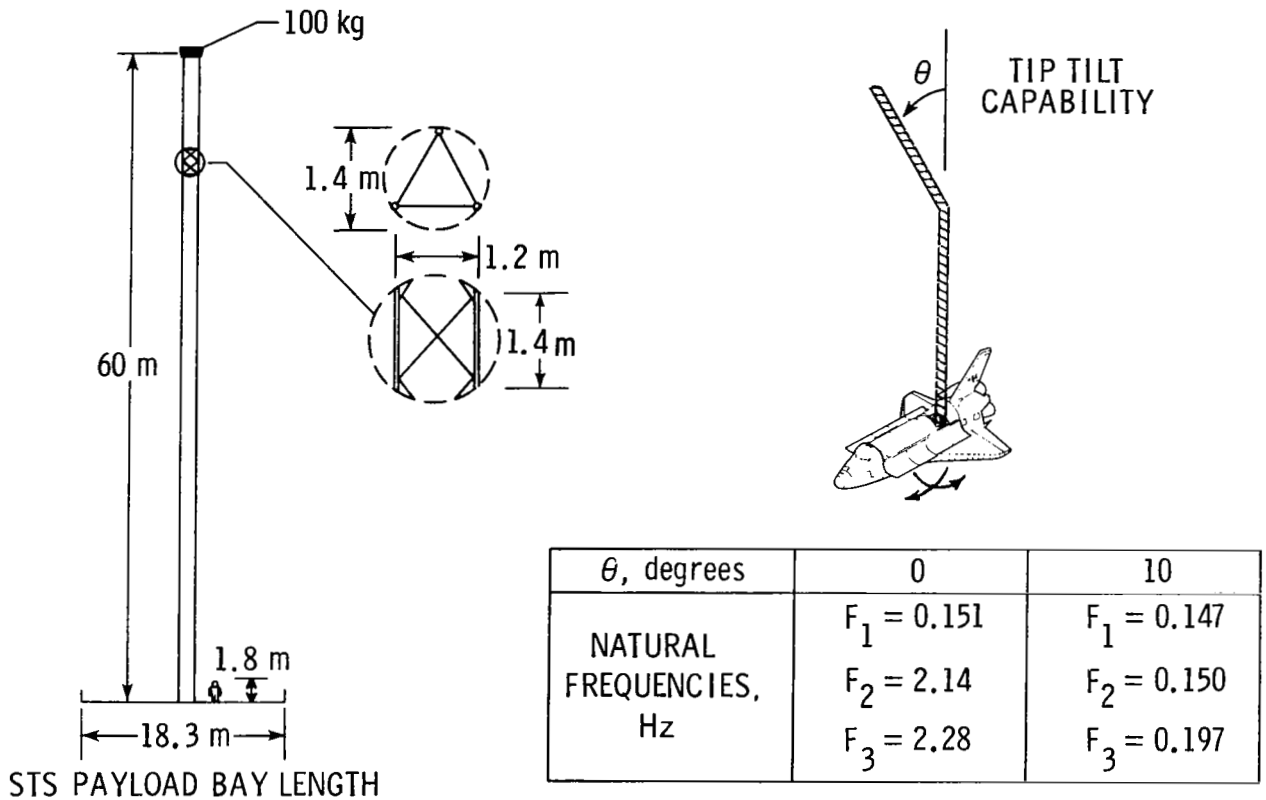

Figure 7

FLIGHT TEST SEQUENCE

The orbital test sequence shown here allows verification of safety by checking predictions at partial deployment (i.e., at higher frequencies there is less potential for Shuttle control interaction) before extending to full length. Such a test sequence may require more than one deployment on the same flight to allow time for analysis verification. Test times could thus be kept to reasonable lengths. (See fig. 8.)

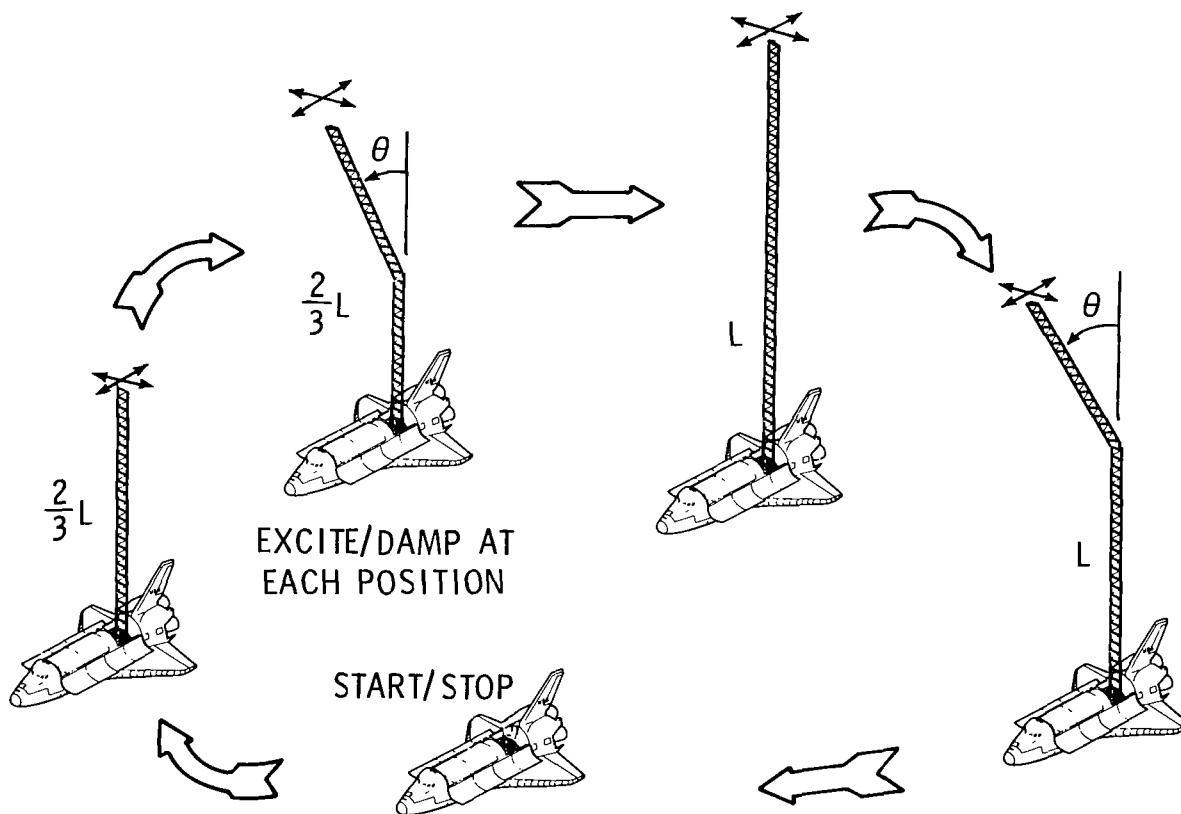

Figure 8

RESEARCH ON PREDICTION OF JOINT-DOMINATED STRUCTURES

Joint-dominated truss structures are expected to be used frequently in future large space systems. However, the properties of these structures are insufficiently understood, particularly if a need for accurate mathematical models is critical, as it is in many control strategies. This is in large part due to the nonlinear behavior of joints as illustrated in the upper right of this figure. Joints at different locations in a structure under Earth's gravity may carry different initial static loads due to the weight of the portion of structure supported by that joint. Joints in zero gravity and hence under no static load may behave quite differently. In fact, many joint designs may have dead bands (slop) under zero load or radical stiffness differences in tension and compression.

Improving the prediction of structural behavior where many such joints are present requires a progressive study of components, subassemblies, and assemblies in ground tests followed by orbital flight tests to evaluate gravity effects. (See fig. 9.)

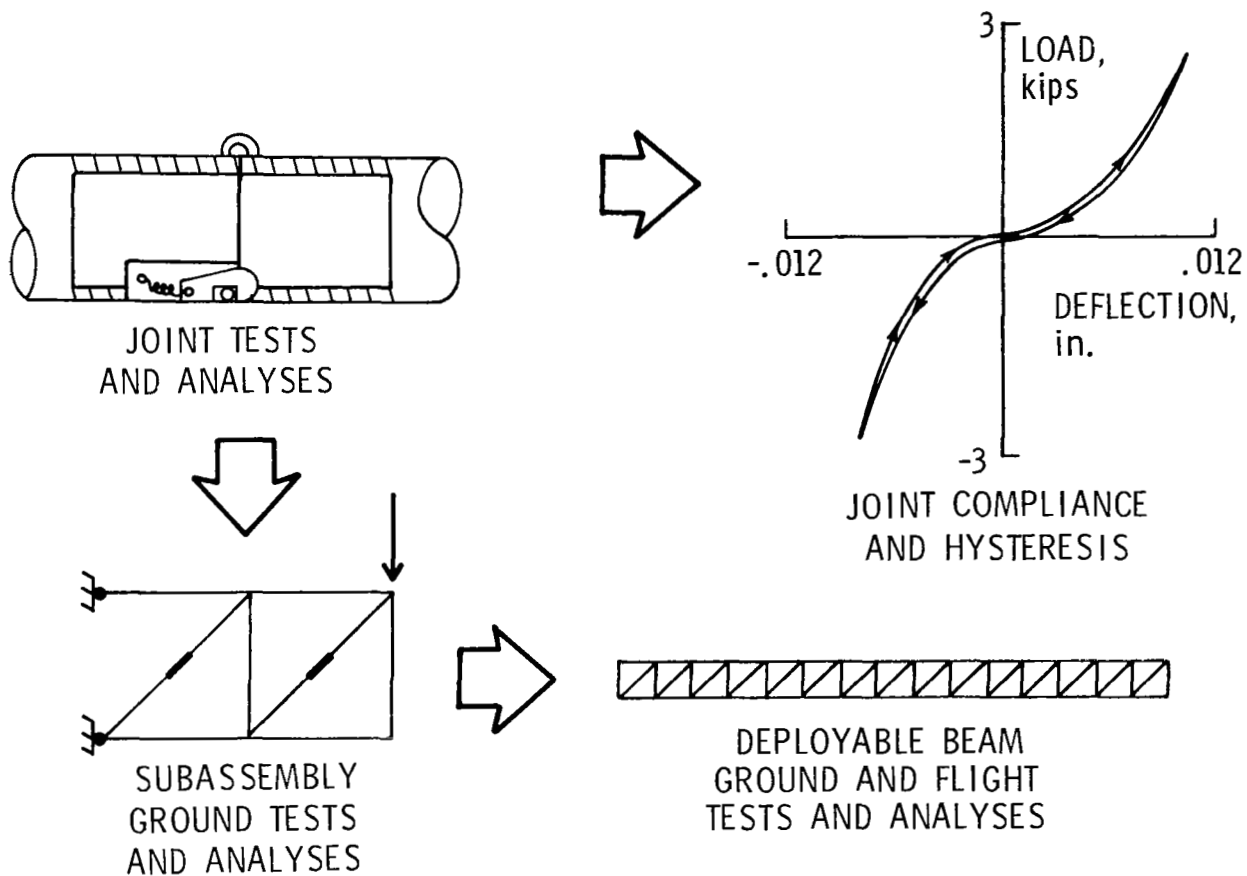
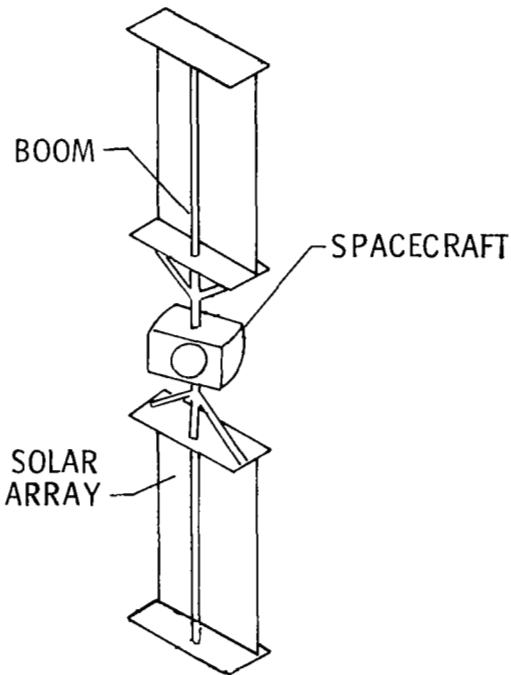

Figure 9

DAMPING ON HERMES SPACECRAFT

In addition to stiffness differences in the Earth's environment and orbit, structures are expected to have differences in damping or energy dissipation characteristics. Figure 10 summarizes results of the only quantitative study known to the authors and compares the two environments. Contrary to Earth-based experimental studies by other researchers which have indicated that damping in space would be less than on Earth, the data indicates the opposite. The study was not sufficiently detailed to determine whether these results are generally true or, instead, are unique to the Hermes spacecraft. Impact in joints with free play was conjectured by the experimenters as the probable damping mechanism. Joints without free play may exhibit increased bonding under the vacuum and temperature conditions of space and result in reduced damping. Only by in-orbit tests on a well-understood structure can this matter be settled sufficiently for general structural applications.

It is interesting to note in this data that the damping in some modes, both on Earth and in orbit, was less than one percent of critical, even with joints having free play. Also, the modes measured in ground tests do not coincide completely with those measured on orbit. Different mechanical mechanisms (or, possibly, data acquisition and analysis errors) are in effect in the two environments. A more in-depth experiment is needed.



FREQ. Hz	DAMPING, % GROUND TEST	DAMPING, % FLIGHT TEST
.151	.006	.030
.171	.016	
.278	.020	.030
.434	.009	.022
.504	-	.008
.793	-	.016

REF. 1

Figure 10

DYNAMIC TEST METHODS FOR LONG BEAMS

Of all potential large space structural components, beams are among the simplest to ground test. This by no means assures that a simple valid test can be conducted for any size beam. As beams become long, frequencies become low, and gravity effects in dynamic tests become difficult to remove. Three approaches to tests on a long uniform beam are shown in figure 11 - vertical suspension by one end, horizontal suspension on lightweight cables, and tests on segments which are then mathematically joined to predict the full-beam behavior. In the vertical test, tension along the beam varies with height producing a large stiffening effect at the top. (The opposite approach, base support, produces equally detrimental compression loads.) In the horizontal tests, cables must be long enough to prevent interference between the first beam-bending mode and the pendulum mode of the beam on the cables. For very low-frequency beams ($f_1 < 1$ Hz), this results in cables having lateral vibration frequencies which interfere with higher beam modes. The third approach, tests on substructures (pieces) with mathematical extrapolation, leads to questionable treatment of connection behavior and very poor understanding of overall beam damping.

The validity of dynamic ground tests on low-frequency, lightweight beams (particularly where joints are present) is questionable; on other structures, it is even more questionable. A test program that compares various ground test methods with flight results on a large beam is not too simple a starting place; it may be the only sensible one.

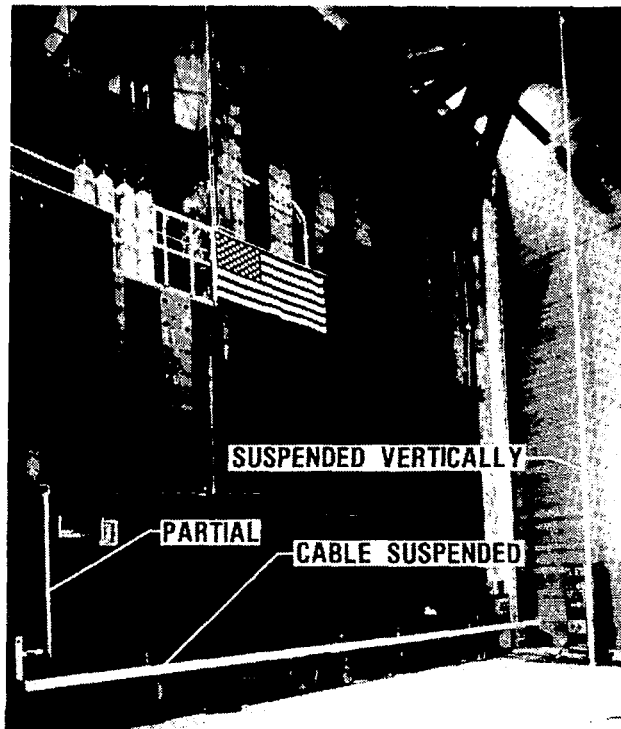

Figure 11

OVERCOMING GRAVITY IN GROUND TESTS

In the previous figure, all significant motion of the test articles was parallel to the ground plane and not opposed directly by gravity. For three-dimensional motion, as for the antenna dish shown on the left, motion in the vertical direction must be permitted by mounting on a soft suspension system. However, if the structure being tested has a very low first natural frequency, prevention of interference of the springs (and possibly the supporting structure to which they are attached) can require impractically soft springs. This is illustrated in figure 12 (right) where the static deflection of the suspended test article is shown as a function of test article first natural frequency, requiring the bounce frequency of the structure on the springs to be one-fourth the first structural resonance. Tests on the Mast test article with the tilt shown in figures 7 and 8 would be used to evaluate this type of test.

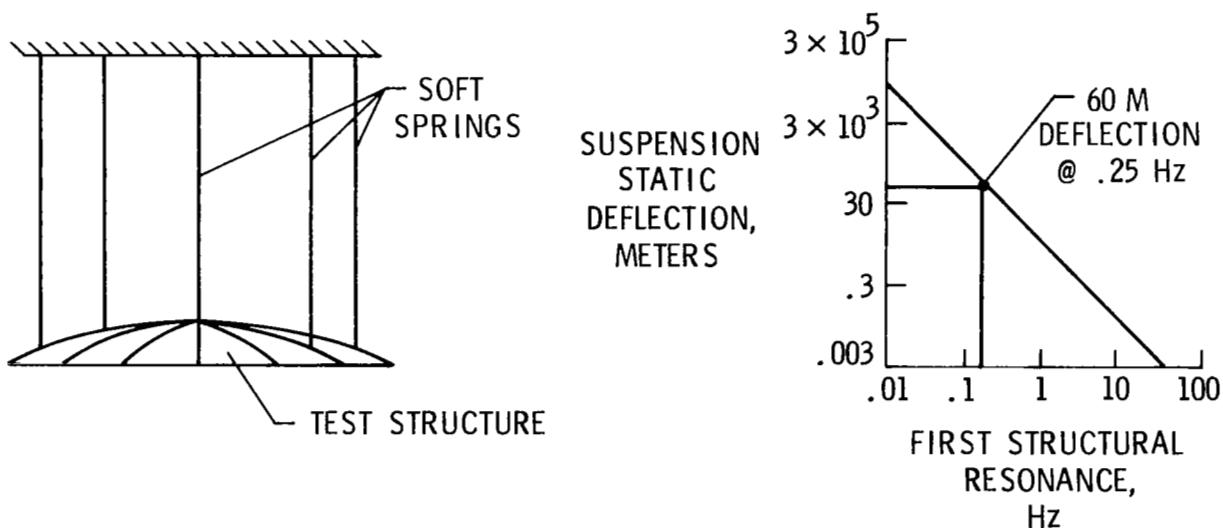

Figure 12

MAST SENSOR REQUIREMENTS

One of the most difficult problems with defining both flight experiments and active control systems for large flexible structures is sensor availability. The requirements are defined by displacements which are large relative to conventional dynamic sensor capabilities and yet, because of extremely low frequencies, accelerations (and velocities) are very low. The spatial range over which distributed measurements must be made and the environmental lighting variation strain available optical techniques.

The dashed line in figure 13 showing tip deflection and acceleration versus beam length represents the current Mast design range. The crossover with the middle diameter/length ratio line ($D/L = 0.02$) is the expected peak under Shuttle maneuver control motions. Instruments are thus ranged such that the limits of available technology are explored by varying these control motions.

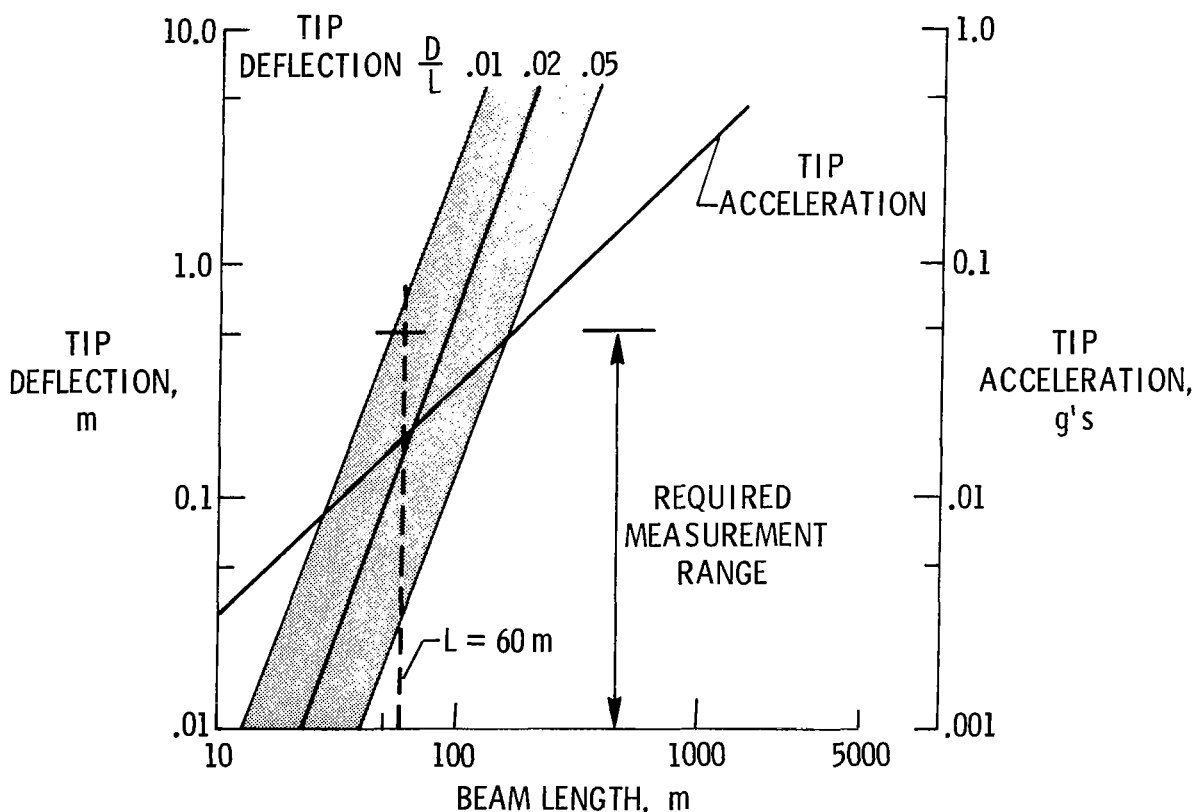

Figure 13

RESEARCH ON CONTROL/STRUCTURE INTERACTION

The deployable truss beam Mast experiment is initially planned for structural configuration accuracy, deployment, and dynamics studies. However, a natural follow-on would be studies of control/structure interaction. It provides the capability to study the problems indicated in the left of figure 14 with particular versatility added by the tilt effect shown on the right. Open- and closed-loop control experiments that emphasize algorithm performance with realistic physical structure, actuator, and sensor characteristics could provide considerable information about advanced control methods. Such information would remove much doubt as to the degree to which advanced algorithms can be practically relied on for future spacecraft design.

SDD/ FDCD/ UNIVERSITY
RESEARCH ACTIVITY

GROUND TEST/ FLIGHT
COMPARISON

SYSTEM I. D.
OF COMPLEX
STRUCTURES

ACTIVE AND PASSIVE
VIBRATION CONTROL

REDUCED-ORDER
CONTROLS

PARAMETER-
ADAPTIVE
CONTROL

ACTUATOR
TECHNOLOGY



DEPLOYABLE BEAM
FLIGHT EXPERIMENT



TILT EFFECT

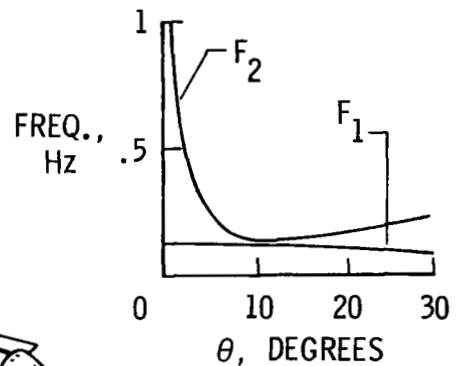

Figure 14

PLANNED MAST RESEARCH ROLES

The Mast research effort is viewed as a combined ground-orbital laboratory experiment of general interest to the aerospace engineering research community and, as such, available for participation by investigators in various roles. Technical suggestions and proposals for research will be considered and adjustments to the effort to accommodate proposed studies will be made as reasonably practical. (See fig. 15.)

- o NASA-LANGLEY IN-HOUSE RESEARCH (SUGGESTIONS WELCOMED)
- o DATA SUPPLIED TO RESEARCH COMMUNITY
- o HOST STRUCTURE FOR EXPERIMENTS BY OTHERS

Figure 15

REFERENCE

1. Garg, S. C.; Hughes, P. C.; Millar, R. A.; and Vigneron, F. R.: Flight Results on Structural Dynamics from Hermes. J. of Spacecraft & Rockets, March-April 1979, pp. 81-87.



ERECTABLE BEAM EXPERIMENT

Walter L. Heard, Jr.
NASA Langley Research Center
Hampton, Virginia 23665

SPACE STATION CONCEPT

Figure 1 shows a space station concept that illustrates extensive use of beam-like truss structures. Whether these beams are deployed (unfolded) or erected (assembled strut by strut) on orbit, it is important to have a thorough knowledge of their structural and dynamic behavior and control requirements under flight loads in the space environment. The MAST/STEP experiment proposal is conceived to provide such knowledge. The present paper reviews some results of LaRC assembly tests of erectable structures and describes a simple, inexpensive first generation EVA assembly experiment for an erectable beam. This proposed experiment is intended to be a HITCHHIKER payload for earlier Shuttle flights which will precede STEP by two to three years. The experiment is very basic but should provide an accurate assessment of EVA productivity when using an assemblyline approach to space construction. This EVA assemblyline method for constructing erectable beams can also be accomplished effectively on STEP for the MAST experiment. After the beam is assembled, the same tests proposed for MAST would still apply.

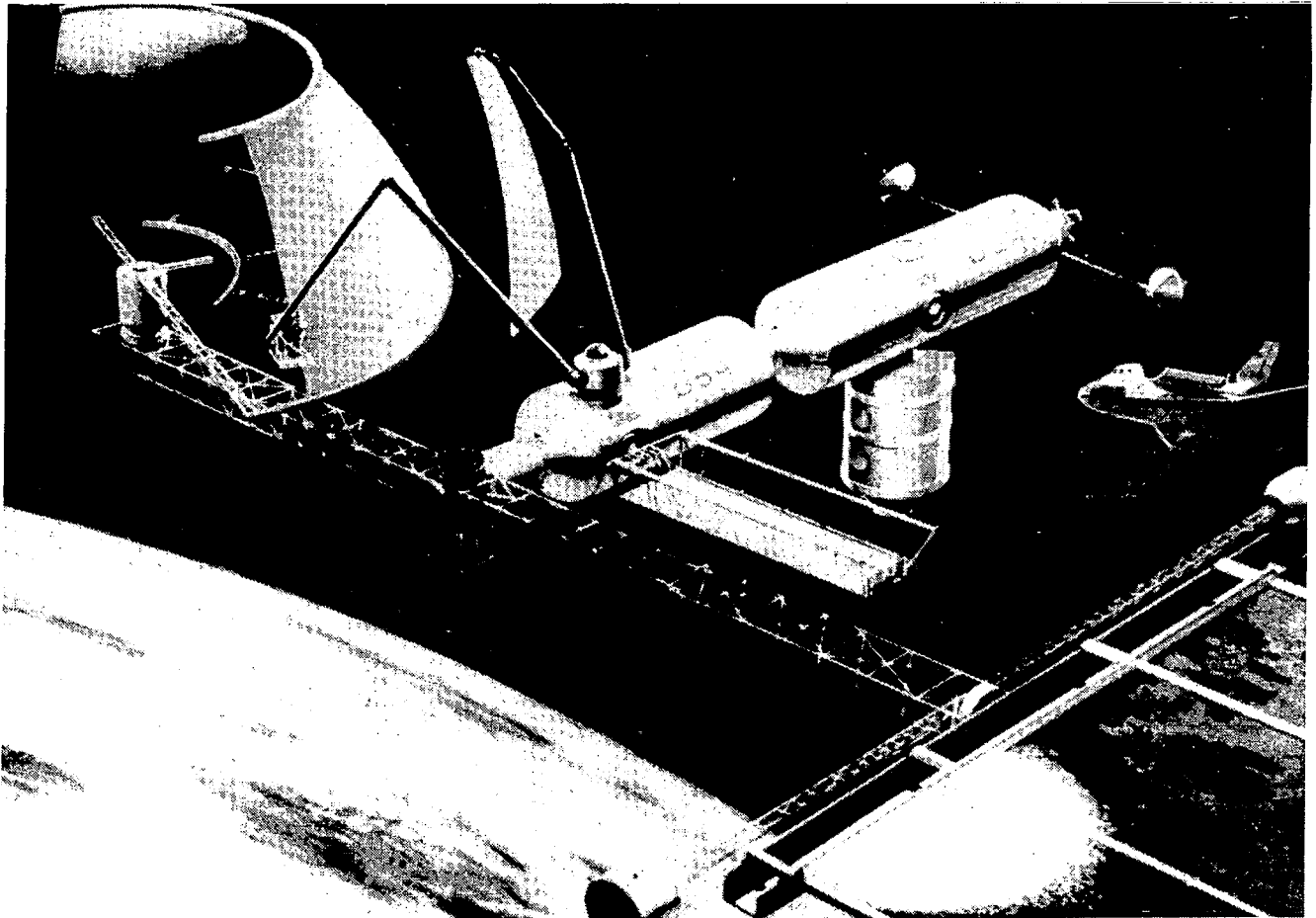

Figure 1

ERECTABLE BEAM 1-G ASSEMBLY TEST

Erectable structures are not as kinematically complex as deployables. Joints are much simpler and lighter in weight and erectable structures have superior packaging characteristics. The major unknowns, however, are orbital assembly time and effort. A review of some promising results of earlier LaRC studies in this area are presented in the next two figures. Figure 2 shows a 1-g beam assembly performed about two years ago at LaRC. An assembly sequence was developed for a 38-strut beam. The assembly was manual with two men maneuvering the struts and performing the structural connections. However, the men and the material (struts and nodal joints) were transported to appropriate work stations within a small, prescribed work envelope during the assembly by mobile, motor driven platforms. The 38 struts were assembled in approximately 15 minutes by the two-man crew in street clothes. The finished beam was about 17 meters long.

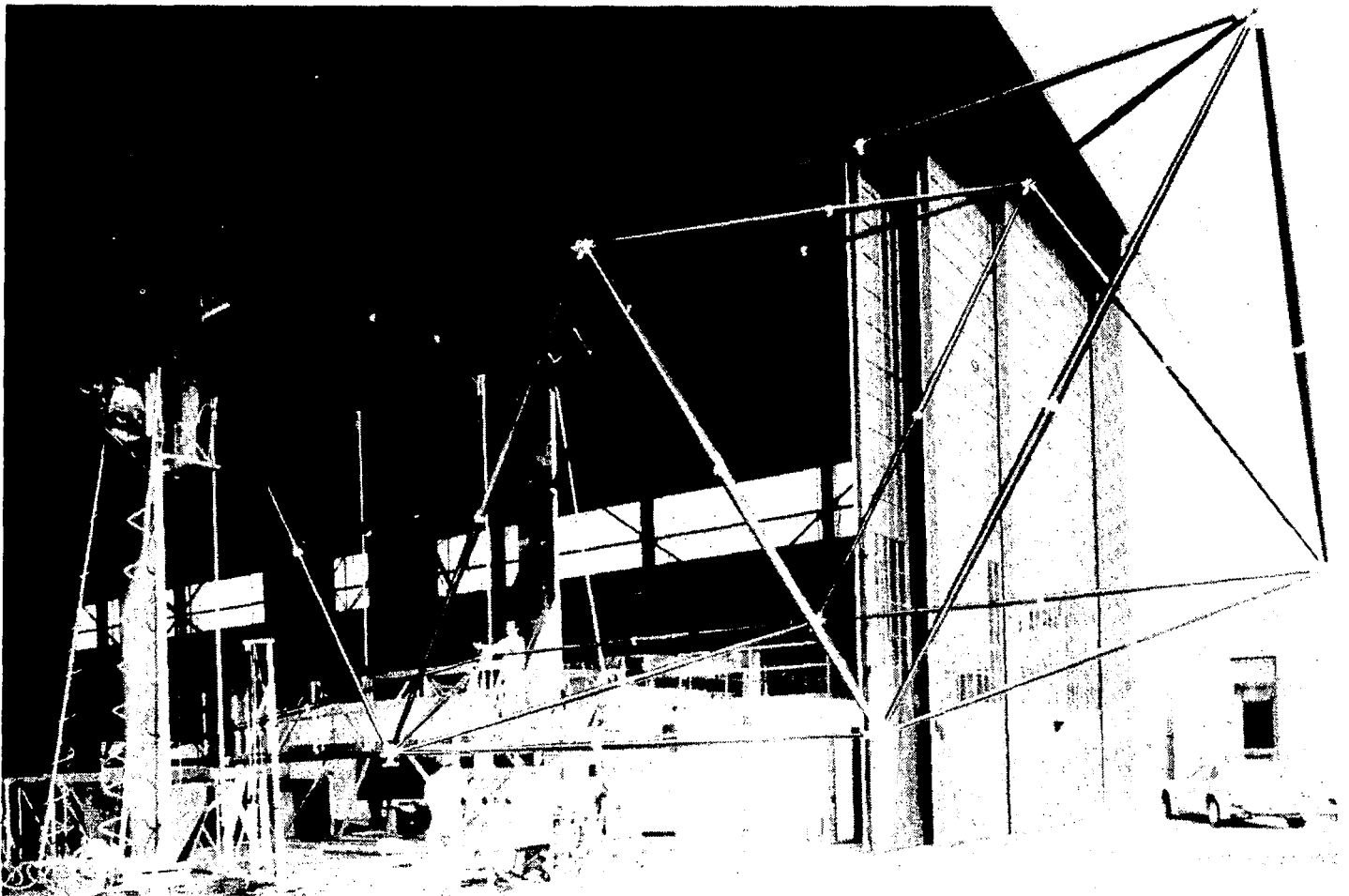

Figure 2

ERECTABLE BEAM NEUTRAL BUOYANCY ASSEMBLY TEST

Figure 3 shows a simulated 0-g (neutral buoyancy) assembly test performed in the Marshall Space Flight Center Neutral Buoyancy Simulator. This is the same 38-strut beam shown in Figure 2. Two pressure-suited test subjects manually assembled the beam. They were mechanically moved as in the 1-g test to the appropriate work stations. The test subjects were never required to leave the foot restraints during the assembly. The struts and test subjects were neutrally buoyant and the 17-meter beam was assembled in about 53 minutes. A subsequent neutral buoyancy test was also performed in SCUBA, but with the two test subjects attached to the work platforms. The assembly was performed in 24 minutes. By comparing assembly times from these three tests (1-g, street clothes; 0-g, pressure suits; 0-g, SCUBA) effects of water drag and space suit restrictions were estimated, and an assembly rate of about 38 s/strut was determined for space. The struts for these tests were 5.5 meters long. Shorter struts could probably be assembled at an even faster rate. The assembly rate is independent of the size of the structure being assembled and, therefore would be applicable for large structures that are impractical to build in total manual operation with no assembly aids.

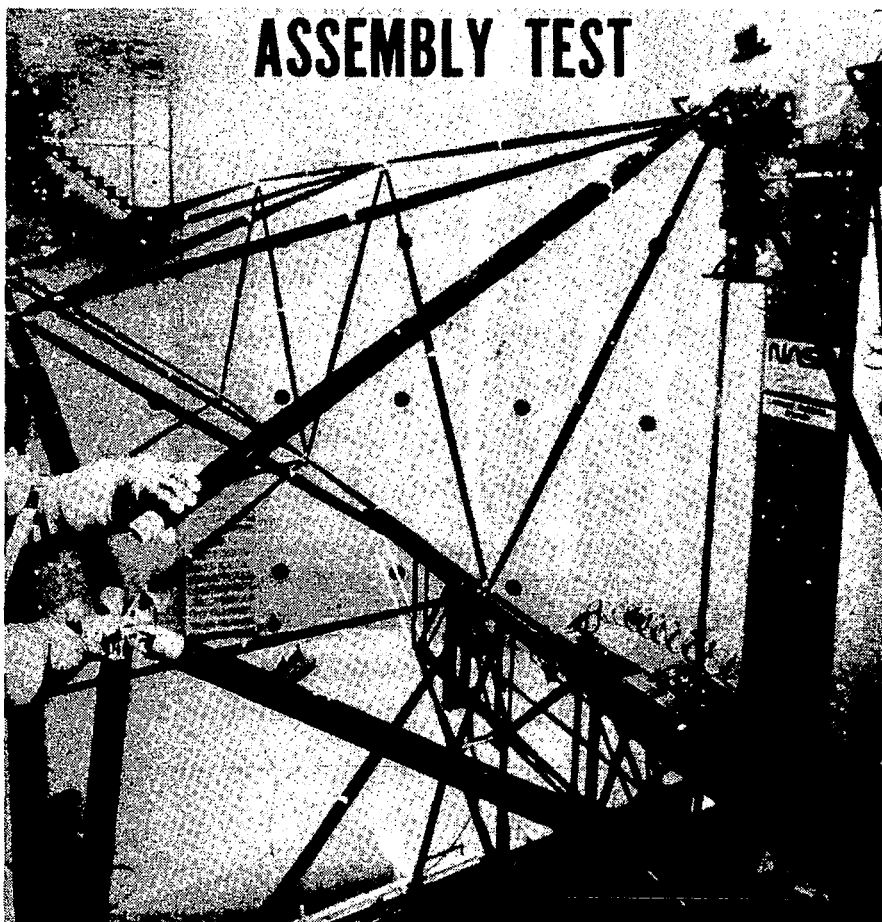

Figure 3

ERECTABLE BEAM

Currently at LaRC we have been focusing on the technology for erecting a beam using one astronaut. An example of a 2-meter-diameter 100-meter-long erectable beam is shown in Figure 4. The packaged beam and the erected beam are shown to scale with the Space Shuttle. The estimated assembly time of the 453-strut beam by one astronaut assisted by the assembly aid shown in Figure 5 is three to six hours.

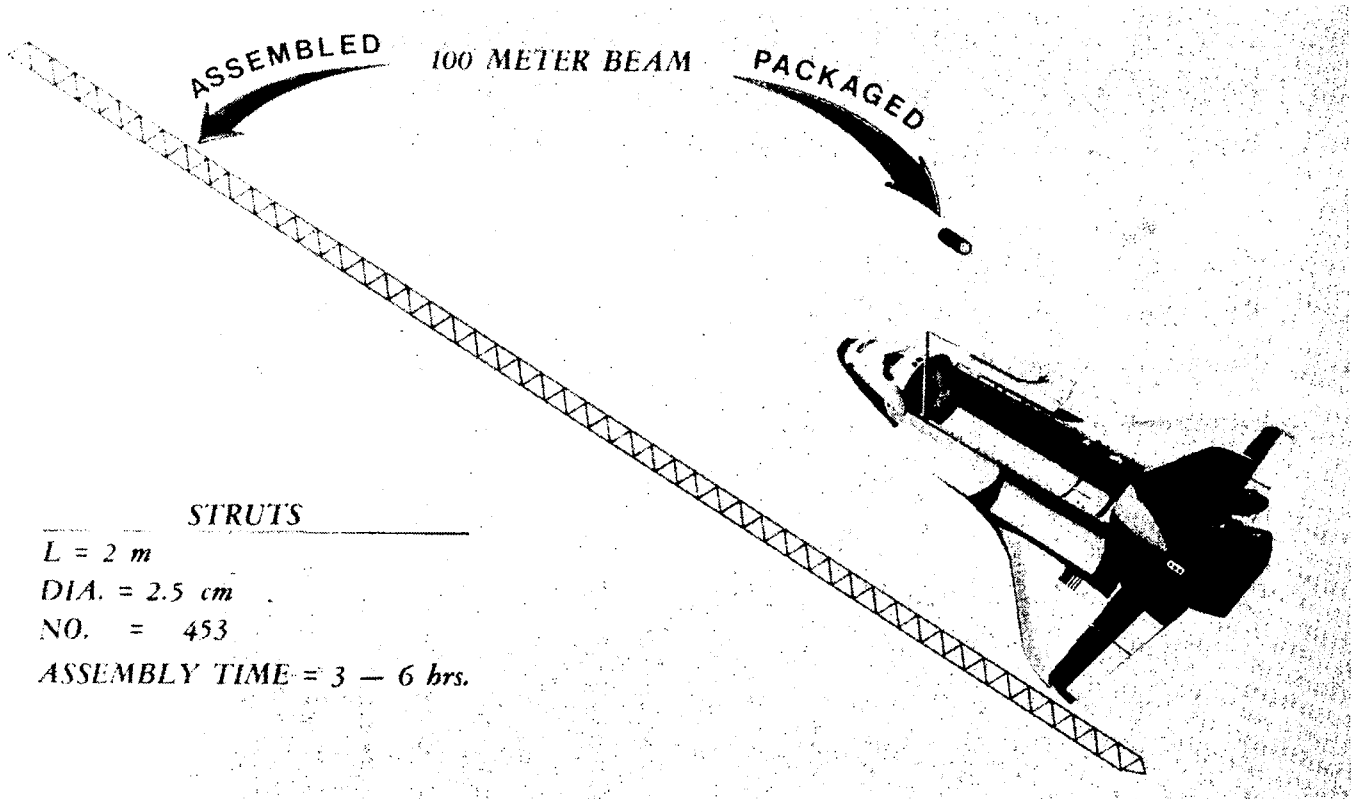
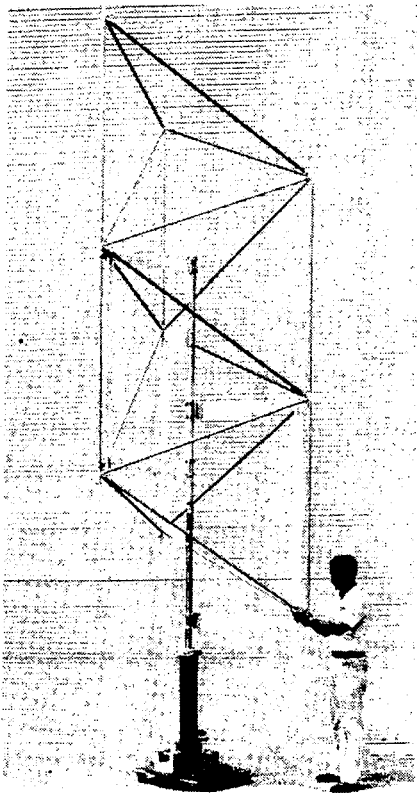

Figure 4

BEAM ASSEMBLY CONCEPT DEVISED

Figure 5 shows a mockup and a schematic of the assembly fixture supporting two bays of an erectable beam. A modified tetrahedral beam was selected for our in-house studies. The schematic of the beam and assembly fixture is shown on the right. The single astronaut erects the beam using struts with quick-attachment joints. His boots are secured to a platform which can telescope up or down and can rotate on a swing arm around the axis of the beam to permit ready access to all joints. As each bay is assembled, the beam is registered outward by the telescoping assembly fixture and the process is repeated one bay at a time until the beam is complete. Utilities could be readily integrated during this assembly process. The hardware for this beam and assembly aid is being fabricated, 1-g tests will be performed in October 1983, and neutral buoyancy assembly tests are scheduled for March 1984.

MOCKUP



ERECTABLE BEAM EXPERIMENT

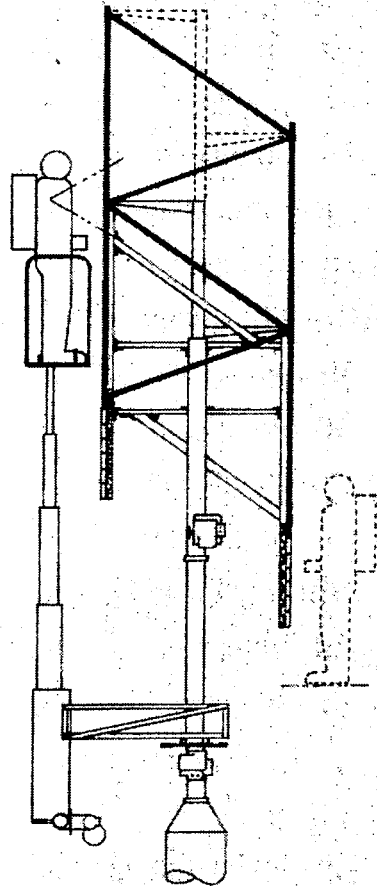

Figure 5

ASSEMBLY CONCEPT FOR CONSTRUCTION OF ERECTABLE SPACE STRUCTURES
"ACCESS"

Figure 6 gives the acronym and its meaning for LaRC's proposed HITCHHIKER flight experiment. HITCHHIKER is a Space Shuttle carrier system for experiments with modest accommodation requirements. It is intended to offer the opportunity for flight on a more frequent and economical basis than previously available. The ACCESS flight experiment proposed by LaRC is a simple, inexpensive first generation space construction experiment. In keeping with the time and resources available, the assemblyline concept proposed for access and described in the next several figures is very basic.

ASSEMBLY CONCEPT FOR CONSTRUCTION OF ERECTABLE SPACE STRUCTURES

" ACCESS "

PROPOSED HITCHHIKER FLIGHT EXPERIMENT

Figure 6

OBJECTIVES

Figure 7 gives the objectives of ACCESS. The experiment would allow evaluation of the assemblyline concept for efficient on-orbit manual assembly of large network-type structures. ACCESS would eliminate many unknowns and speculations about EVA assembly and thus reduce the risk factor associated with related manual assembly concepts. Finally, ACCESS would determine true 0-gravity assembly rates for correlation with simulated 0-g ground tests.

- *EVALUATE A CONCEPT FOR EFFICIENT ON-ORBIT MANUAL ASSEMBLY OF LARGE NETWORK STRUCTURES*

- *REDUCE RISK FACTOR ASSOCIATED WITH RELATED MANUAL ASSEMBLY CONCEPTS*

- *DETERMINE ASSEMBLY RATES FOR CORRELATION WITH SIMULATED 0-G GROUND TESTS*

Figure 7

TECHNICAL APPROACH

Figure 8 gives the technical approach. ACCESS is being designed to use no motors at all. All maneuvers will be manual, using two astronauts in EVA. The experiment will interface with the MPES (multi-purpose experiment support structure) pallet.

- *DEVELOP A TWO-MAN ASSEMBLY PROCEDURE USING STATIONARY WORK STATIONS AND AN ASSEMBLY FIXTURE FOR ASSEMBLYLINE PRODUCTION OF A BEAM-LIKE TRUSS*

- *ASSEMBLY EXPERIMENT WILL INTERFACE WITH THE MPES PALLET*

Figure 8

ACCESS FLIGHT EXPERIMENT HARDWARE
(STOWED CONFIGURATION)

Figure 9 shows the ACCESS hardware (shaded structure) in its stowed configuration. It consists simply of two fixed foot restraints, a strut canister, and an assembly fixture. The assembly fixture is a pole and has three guide rails shown folded along the pole. The pole pivots on a bearing to an upright position with respect to the MPSS pallet. The bearing axis is perpendicular to the side of the pallet and the pole axis. When orbit is achieved, two astronauts get into the foot restraints, crank the pole to its upright position, and deploy the guide rails.

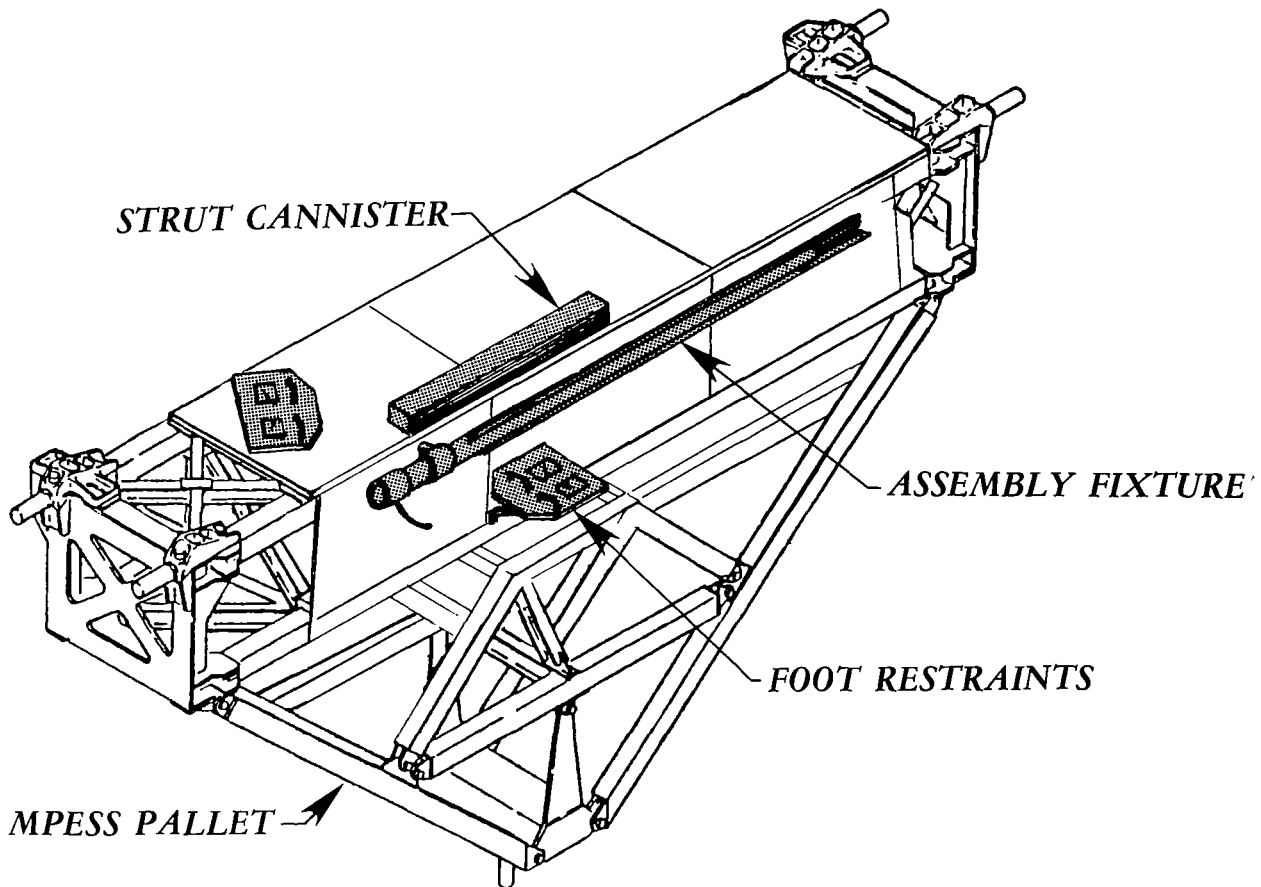

Figure 9

ACCESS FLIGHT EXPERIMENT

Figure 10 shows the assembly fixture deployed. It is two truss bays long. The beam is built strut by strut, one bay at a time. The astronaut on the left works with the upper joints and the one on the right works with the lower joints. The assembly fixture can also be rotated about the axis of the center pole to provide access to all the joints. When a bay is completely assembled, it is manually pushed upward along the guide rails and another bay is assembled underneath. The process is repeated until the beam is complete.

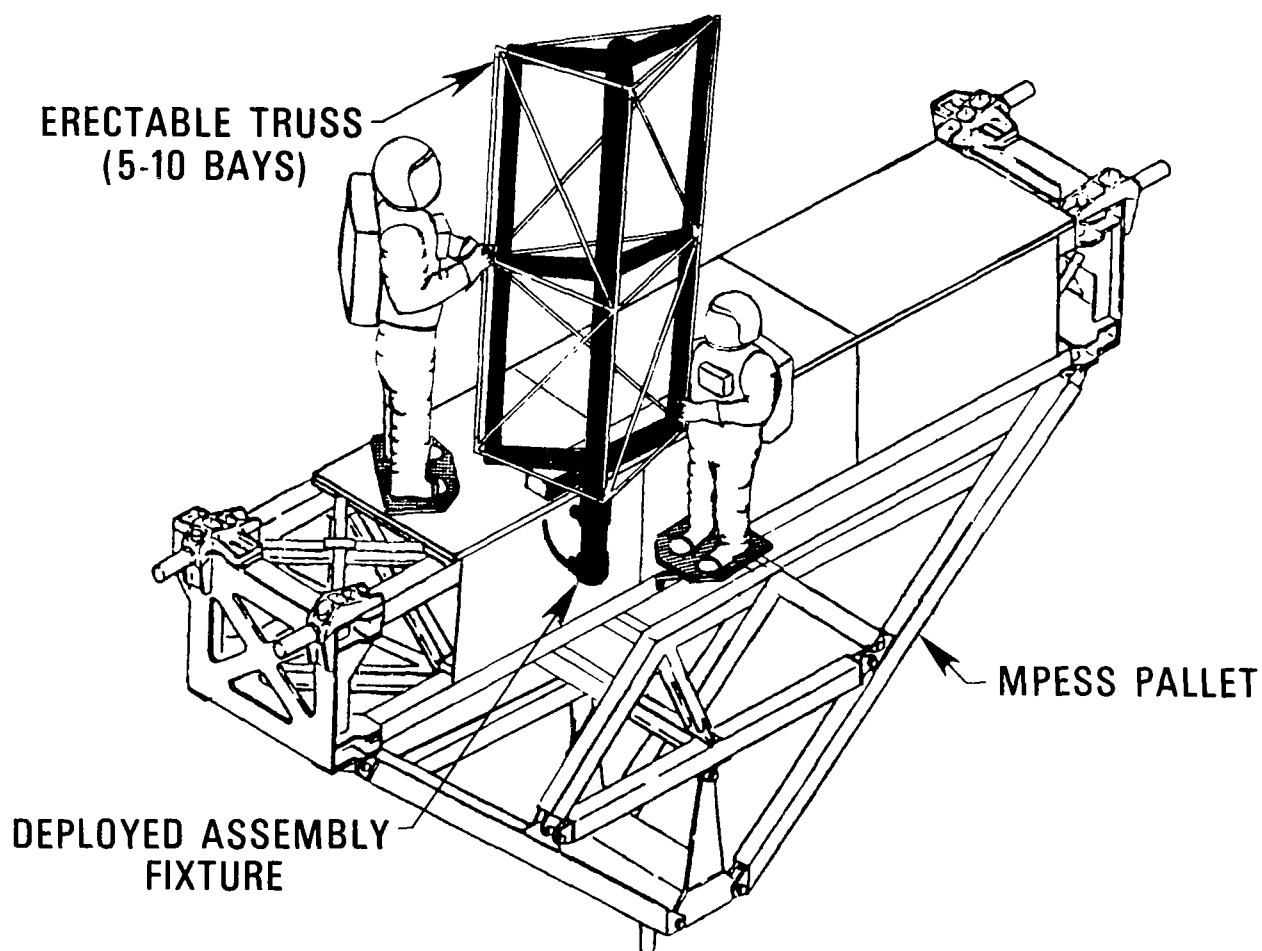

Figure 10

JUSTIFICATION

Figure 11 gives the justification for ACCESS. An experiment such as ACCESS is needed to prove that high-rate orbital assembly of structures is achievable using simple manual state-of-the-art techniques. A successful test could accelerate the acceptance of erectable structures in space and thus maximize use of the STS payload capability.

- *NEEDED TO PROVE HIGH-RATE ORBITAL ASSEMBLY IS ACHIEVABLE USING SIMPLE MANUAL TECHNIQUES*

- *EXPERIMENT WILL ACCELERATE THE ACCEPTANCE OF ERECTABLE STRUCTURES IN SPACE*

- *ERECTABLE STRUCTURES WITH THEIR SUPERIOR PACKAGING AND SIMPLIFIED STRUCTURAL CHARACTERISTICS MAXIMIZE USE OF STS PAYLOAD CAPABILITY*

Figure 11

SUMMARY:
ERECTABLE BEAM APPLICABILITY TO MAST/STEP EXPERIMENT

Figure 12 summarizes the erectable beam applicability to the MAST/STEP experiment. High manual assembly rates have already been demonstrated in neutral buoyancy tests and use of an erectable beam would eliminate extension/retraction complexity associated with deployable beams. The erectable beam assembly aid is easily adaptable to general truss configurations and structural appendages could be accommodated with the use of actuators. Finally, the ACCESS flight experiment precedes MAST by two to three years and will provide mature, space proven assembly/disassembly technology on which to base the MAST experiment.

- ***HIGH MANUAL ASSEMBLY RATES DEMONSTRATED IN SIMULATED 0-G TESTS***
 - ***ELIMINATES EXTENSION/RETRACTION COMPLEXITY OF DEPLOYABLES***
 - ***GENERAL TRUSS CONFIGURATIONS WITH STRUCTURAL APPENDAGES READILY ACCOMMODATED***
 - ***ACCESS FLIGHT PRECEDES MAST FLIGHT 2-3 YEARS & WILL PROVIDE MATURE SPACE ASSEMBLY/DISASSEMBLY TECHNOLOGY***
- 
- 

Figure 12

THE STEP/STACBEAM EXPERIMENT
TECHNOLOGY DEVELOPMENT FOR VERY LARGE SOLAR ARRAY DEPLOYERS

Ron Samuels
Astro Research Corporation
Carpinteria, California

**STEP/STACBEAM EXPERIMENT:
TECHNOLOGY DEVELOPMENT FOR VERY LARGE SOLAR ARRAYS**

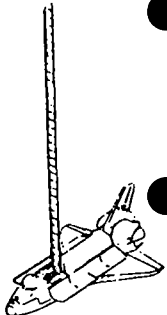
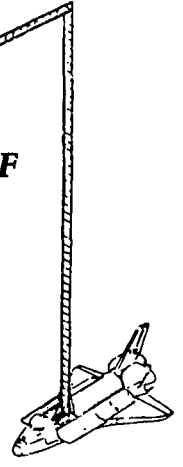
STEP (Space Technology Experiments Platform), as planned by NASA OAST and Langley Research Center, will offer the large space structures engineer some unique test opportunities (see table 1).

The ability to test large, relatively low stiffness systems in a true zero "g," zero-air damping, and space-operational temperature environment will be unparalleled by any practical ground simulation.

Interaction with the Shuttle attitude control system will also provide the engineer with data on the effects of a large and very active spacecraft system on such structures.

- STEP as a development tool to evaluate deployable boom structures
- Evaluation of structural joints in a true zero gravity environment
- Measurement of the dynamic effects of boom deployment and retraction
- Testing of structural nonlinearities in a "real-world" situation
- Evaluation of damping factors not possible in terrestrial simulation of zero gravity
- Testing of mature structures as a phase in project development

Table 1.

SIMULATED ZERO GRAVITY TESTING OF LONG SLENDER SPACE STRUCTURES

Historically, very long (13- to 40-m), relatively low stiffness structures such as the STEM (Storable Tubular Extendible Member) and the Astromast have been tested on floats on a water tank to achieve at least one degree of freedom. Iterations about their centerlines have given a reasonable indication of the true profile of such structures. Vertical testing, counterbalanced to achieve an approximation of zero "g," has also been used with some success on shorter (6- to 8-m) Astromast structures to yield torsional position data for booms carrying magnetometers and similar position-sensitive sensors. However, the limitation of this test technique is rapidly reached. For example, after a very considerable effort to establish data by vertical counterbalanced (for zero "g" simulation) testing of the 13-m-long, 22-cm-diameter Astromast for the Voyager magnetometers (see figure 1), the correlation between vertically upward and vertically downward tests provided a hysteresis in torsional position of greater than 2 degrees. Ultimately, positional reference data were established in flight by providing a magnetic field of known intensity and direction. This field was developed by passing an electric current through a conductor in the rim of the large antenna reflector.

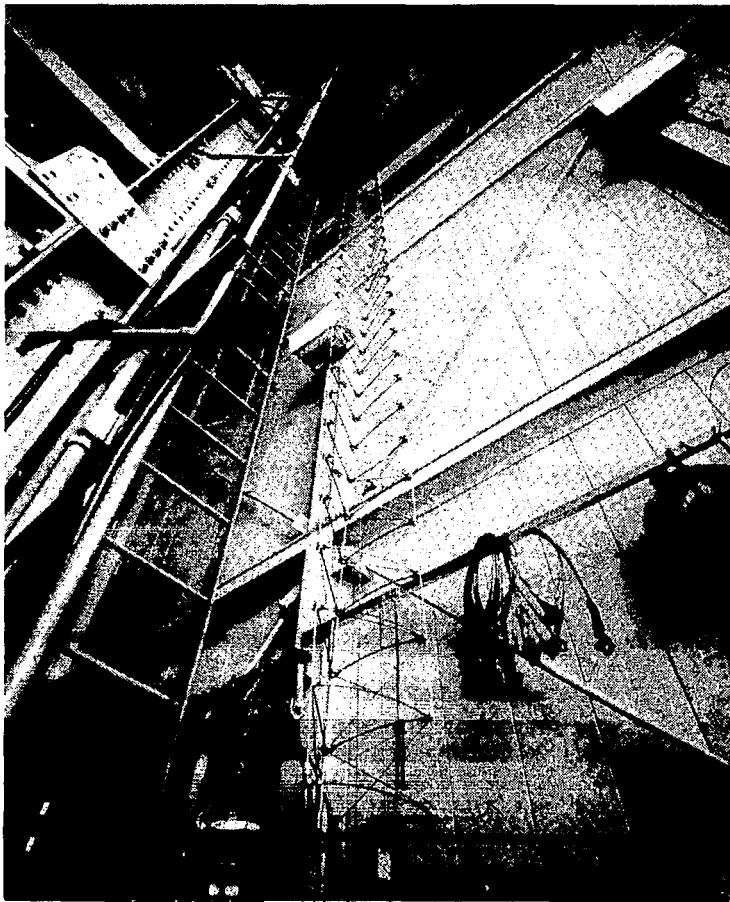

Figure 1.

ZERO GRAVITY EFFECT ON JOINTED STRUCTURES

Simulated zero "g" testing in an Earth environment can provide meaningful and practical information; however, it is impossible to examine the precise performance and nonlinear behavior of, say, a structural clevis joint when unloaded in zero "g." Since most deployable structures designed for use in space utilize single-degree-of-freedom hinges because of reliability considerations, performance of pin hinges becomes very important.

Figure 2a was presented at a recent meeting of the Materials and Structures Committee of SSTAC. It clearly illustrates nonlinear behavior and hysteresis as a clevis joint is exercised through a reverse loading cycle. It is likely that most space structure joints, even those with preloads such as the nearly overcenter hinge (see figure 2b), will display similar nonlinearities.

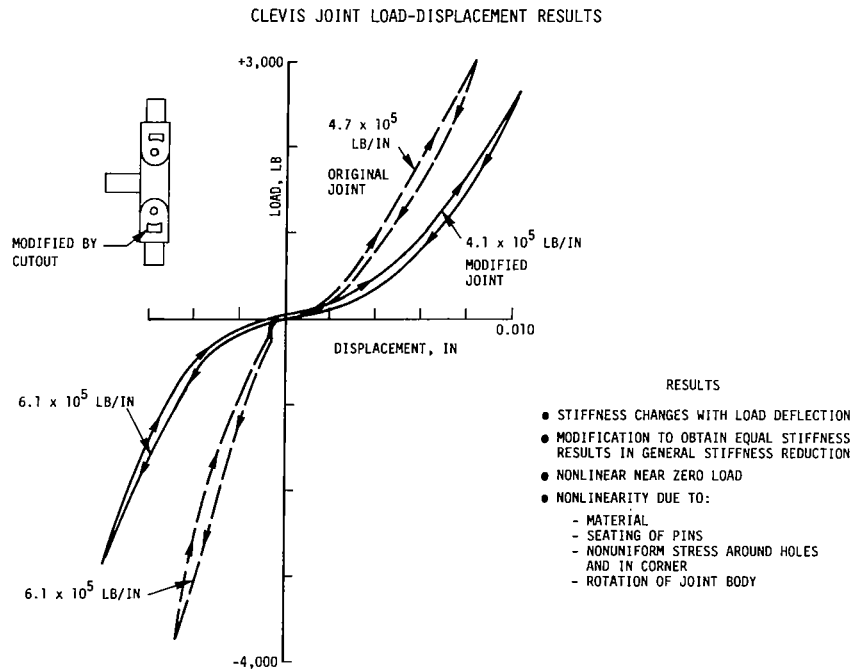

Figure 2a.



Figure 2b.

BOOM TECHNOLOGY FOR EXTENDIBLE SOLAR ARRAYS

Some recent statements from NASA as well as preliminary studies have indicated need for solar array power systems in the 50- to 100-kW range for the Space Station and other projects.

Probably the most mature technology for solar arrays of this magnitude involves the use of flexible blanket systems that are typified by the NASA SEPS/SAFE and the European L-SAT extendible arrays (ref. 1).

Generally, these flexible substrates are extended by Astromast-type deployable lattice booms, a boom technology with considerable flight experience.

Work is currently being performed under a NASA contract to manufacture and test double-laced Astromasts (Supermast) that are 0.75 m in diameter (see figure 3). This deployable boom has a bending strength of more than 2,700 N-m. However, solar arrays of this type usually result in a system with a natural frequency of less than 0.05 Hz and may suffer from the effects of the blanket billowing and impacts on the deployment boom.

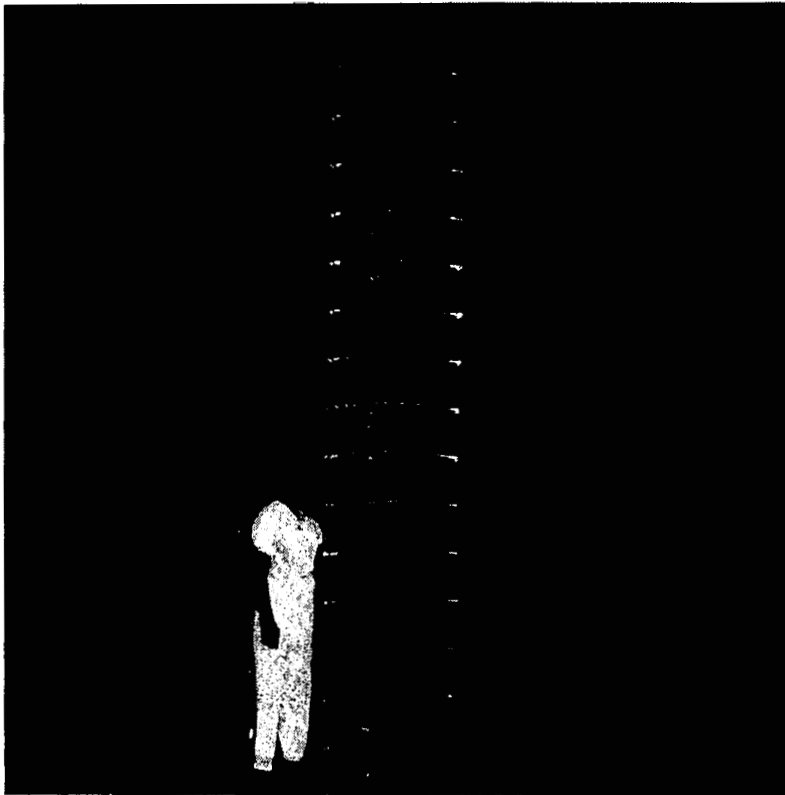

Figure 3.

DEPLOYABLE FLEXIBLE SOLAR ARRAY SUBSTRATE CONTROL

The lack of substrate control and very low system natural frequency are due in part to the complexity of attaching the blanket to intermediary points along the length of the deployment boom during extension. Substrate control is due entirely to the tension developed between the two ends of the deploying structure and the deployment guidewires that extend from the tips of the boom crossbeam and the blanket containment box. Since it is likely that the solar arrays for Space Station will require almost an order of magnitude increase in system natural frequency, some radical improvements must be accomplished in blanket control.

In an attempt to rectify this situation, the STACBEAM (Stacking Triangular Articulated Compact Beam), a robust structure capable of permanent attachment to the substrate, was developed under NASA Jet Propulsion Laboratory funding (see figure 4, ref. 2).

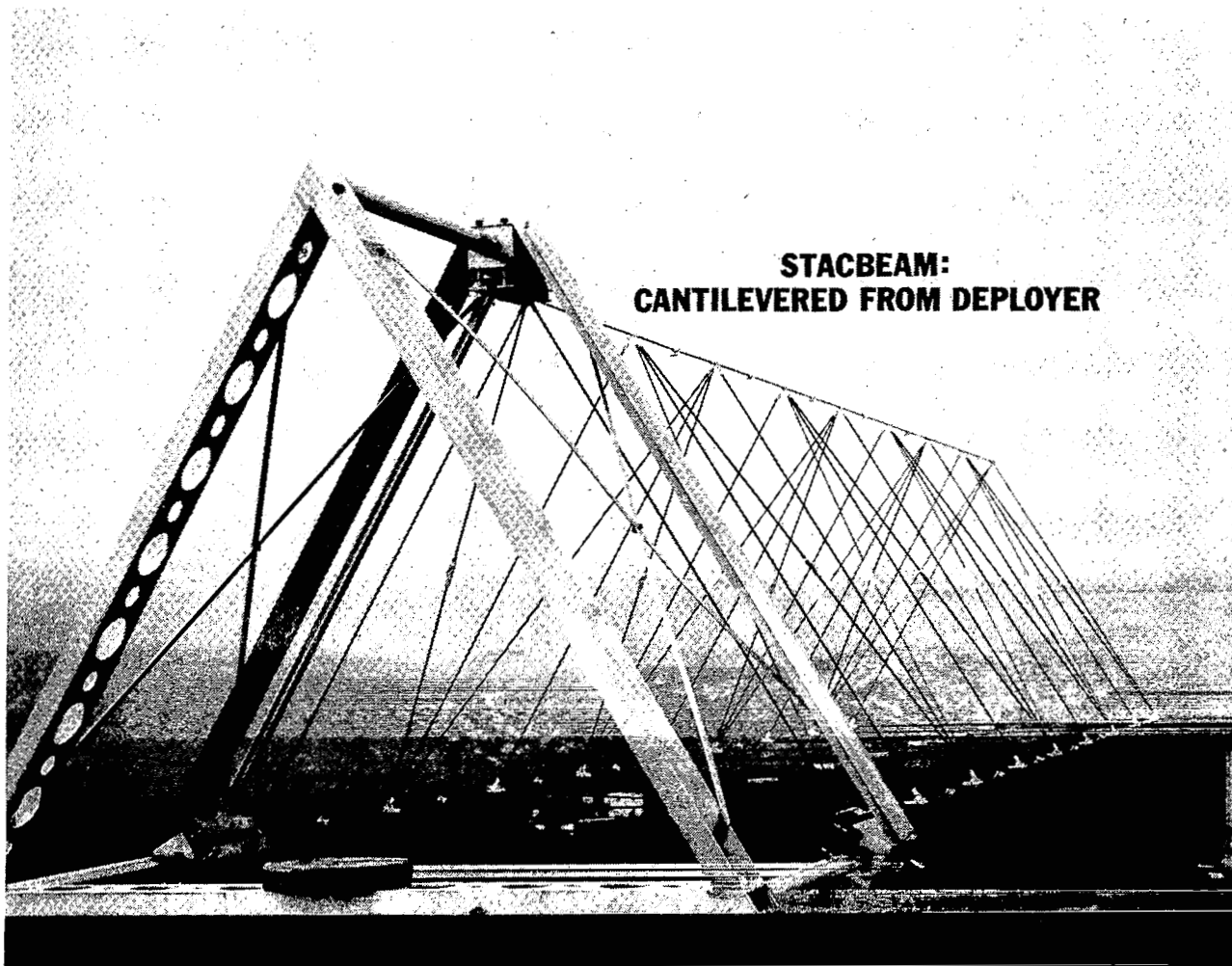

Figure 4.

STACBEAM DEPLOYED EXTENDIBLE SOLAR ARRAY SYSTEMS

The STACBEAM has lent itself to a deployment technique which offers a radical improvement in flexible blanket solar array technology. The general concept of a system for deployment and support of a solar array blanket is shown in figure 5. The system consists of the blanket, its containment structure, the support structure and its deployer, the blanket stiffening battens, and the deployable boom standoffs.

In operation, the blanket is pulled out and supported by the STACBEAM which packages next to the folded blanket. Since the STACBEAM does not rotate during extension, complete control of the blanket is maintained during extension. Deployment of this system occurs one bay at a time in a sequential manner. The deployer provides sufficient rigidity so that beam stiffness is not degraded during the deployment process. The beam lattice material is assumed to be a graphite/epoxy composite in either tube or rod form, its configuration being adjusted so that the cantilever natural frequency of the overall system may be greater than 0.15 Hz (ref. 3).

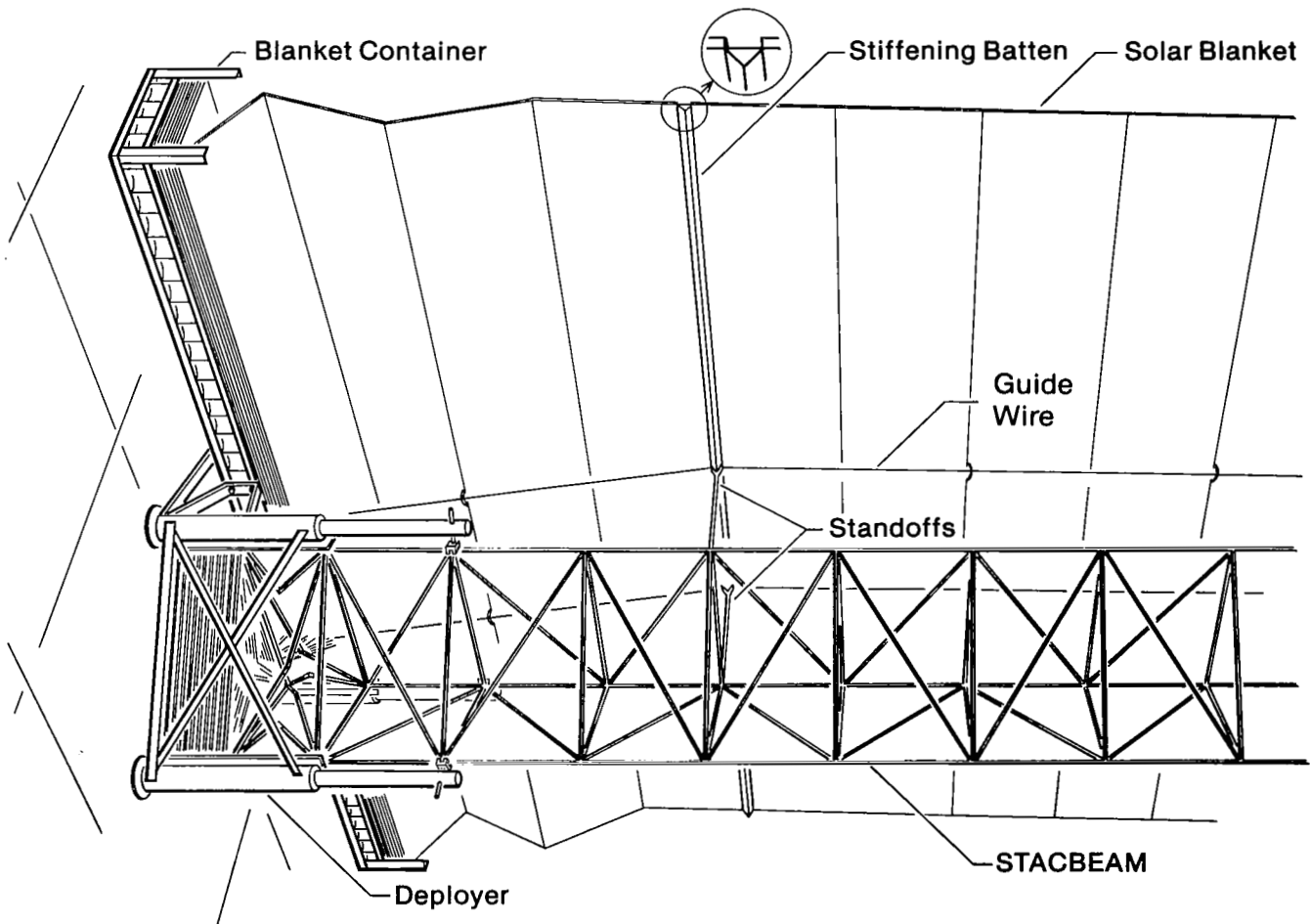

Figure 5.

THE STACBEAM CHARACTERISTICS

In addition to high bending stiffness and strength, the STACBEAM possesses high torsional rigidity due to its nonflexible diagonals. The concept is adaptable to various sizes and loading requirements by changing member diameter and bay length, thus affecting the ratio of packaged to deployed lengths. Lateral stiffness is developed in the blanket by the attached deployable battens. These structures are flat when the blanket is in its packaged condition and become beams of triangular cross section upon deployment; thus, they may be packaged within the blanket system without radically increasing the thickness of the packaged array. The battens in the packaged configuration are attached to the STACBEAM structure by means of stand-off members. The blanket is therefore maintained a finite element distance away from the deploying STACBEAM structure, minimizing radiative heating hot spots on the blanket and also providing a considerable improvement in system stiffness and stability both during deployment and when fully extended.

STACBEAM characteristics not obtainable in a 1-g environment may be established using the STEP system (see table 2).

- Measure Deployment Dynamics
 - Variation in retraction forces at the deployer during extension
 - Secondary forces due to deployment asymmetries
 - Deployer stiffness and freeplay during extension
 - Final shutdown shock after deployment of last bay
 - Retraction effects
- Activate Shuttle ACS
 - Measure deflection of boom tip during acceleration
 - Measure overshoot and deadband deflections
 - Measure damping characteristics
- Repeat Tests at Various Lengths and with Boom Rotated to Test for Preferred Rotational Position

Table 2.

THE STEP/STACBEAM EXPERIMENT

The tests envisaged by utilization of STEP provide for the true evaluation of variations in compression forces at the deployer at each corner of the structure during extension accelerations and secondary forces due to deployment asymmetries resulting from small variations in speed of the extension of each longeron. It will also be necessary to measure the deployer stiffness and freeplay during extension, latching shock of the various joints, and the effects of shutdown deceleration after the last bay has formed in the deployer. Reversal of the whole system will allow evaluation of the retraction phenomena in terms of shock and vibration that may be transmitted to attached structures.

The effect of activation of the Shuttle attitude control system on a jointed structure such as the STACBEAM at full deployment is of considerable importance to the space structure system designer. Data including hysteresis, deadband, and damping characteristics can only be evaluated in a true zero "g" environment as discussed earlier in this paper.

However, a test capability such as the STEP system will provide does not obviate the need for careful and well thought out ground simulation of test samples of the STACBEAM structure. In fact, use of the STEP system will allow such simulations to be characterized and ensure that extrapolations from these tests will be realistic.

THE STEP/STACBEAM FLIGHT EXPERIMENT GOALS

Positioning of alignment and damping sensors and accelerometers is extremely important, and evaluation and test instrumentation must be studied in great detail. Suitable ground testing can evaluate the various types and combinations of instruments and provide a firm background for the subsequent flight testing phases of the development program of a structure such as the STACBEAM.

Subsequent testing of the STACBEAM extended solar array of large proportions can only be performed in a dedicated Shuttle experimental package since it is anticipated that a solar array test structure of the magnitude anticipated for Space Station and similar 50- to 100-kW systems will far exceed the structural capabilities of the STEP pallet attachments. However, the initial ground testing of structures suitably instrumented will provide the necessary background for the next phases of the program to proceed.

The STEP/STACBEAM experiment will provide the large solar array designer with real-time data to allow him to proceed with the next generation of flexible blanket solar array technology systems and, in addition, provide the space structures engineer with considerable design information for future applications of deployable jointed structures.

REFERENCES

1. Hedgepeth, John M.; Adams, Louis R.; and Rockey, D.E.: High Performance Silicon Solar Arrays Employing Advanced Structures. ASME Paper No. 819192, Presented at the 16th Intersociety Energy Conversion Engineering Conference, Atlanta, GA, 9-14 August 1981.
2. Adams, Louis R.: STACBEAM: An Efficient, Low-Mass, Sequentially Deployable Structure. Paper No. 829260, Presented at the 17th Intersociety Energy Conversion Engineering Conference, Los Angeles, CA, 8-13 August 1982.
3. Knapp, Karl: Composite Materials and Deployable Boom Technology. SAE Paper No. 821395, Presented at the Aerospace Congress & Exposition, Anaheim, CA, 25-28 October 1982.



GENERAL REQUIREMENTS FOR SHUTTLE FLIGHT EXPERIMENTS

Edward F. Crawley
Boeing Assistant Professor
Aeronautics and Astronautics
Space Systems Laboratory
Massachusetts Institute of Technology
Cambridge, Massachusetts

GUIDING PRINCIPLES OF FLIGHT EXPERIMENTS

- CLEAR SOUND TECHNICAL OBJECTIVE
- DEMONSTRABLE NEED TO PERFORM THE EXPERIMENT
IN SPACE
- CLEAR EVOLUTION FROM GROUND TO SPACE SIMULATION
TO SPACE, WITH AN ABILITY TO CORRELATE AT
EACH STEP
- NEITHER ECONOMIC, SCIENTIFIC NOR HISTORIC
JUSTIFICATION FOR DEMONSTRATIONS

EXAMPLES OF CURRENT MIT EXPERIENCE

- SPACE LAB: OCULAR VESTIBULAR RESPONSE
- "HITCHHIKER" CARRIER: EASE - EVA ASSEMBLY
OF STRUCTURES EXPERIMENT
- MID-DECK: ROLE OF SCALE IN FLUID AND
STRUCTURAL DYNAMICS IN ZERO GRAVITY
- STEP

POSSIBLE EASE CONFIGURATIONS

O EASE 1

- SIX BEAM STRUCTURE, ASSEMBLED REPEATEDLY
- NO INTERFACES OTHER THAN MECHANICAL
- DEDICATED LIGHTWEIGHT CARRIER
- EMPHASIS ON BODY DYNAMICS, LEARNING, PRODUCTIVITY

O EASE 2

- LARGER STRUCTURE, ASSEMBLED ONCE
- POSSIBLE USE OF MMU AND RMS
- SHARED PAYLOAD ON COPE CARRIER
- SELF-CONTAINED DATA COLLECTION USING COPE POWER
- EMPHASIS ON ASSEMBLY AIDS, LOADS, EXTENDED ASSEMBLY

EASE SPECIFICATIONS

MASS - 500 KG

LENGTH - 2 FEET OF PAYLOAD BAY

CREW - 2 EVA, SIX HOURS

POWER - NONE

ORBITAL REQUIREMENTS - NONE

POINTING REQUIREMENTS - NONE

OPTIONS - USE OF MMU

PREDECESSORS TO EASE

SKYLAB M-151

- ONLY IVA TASKS EXAMINED ON-ORBIT
- ONLY 1-G TRAINING USED FOR COMPARISON

PREVIOUS EVA EXPERIENCE

- ONLY QUALITATIVE RESULTS
- FEW TASK REPETITIONS
- NO DATA BASE OF NEUTRAL BUOYANCY SIMULATIONS
- TASKS NOT DESIGNED FOR CORRELATION

SPACE SYSTEMS LAB TESTS

- HARDWARE BASED ON MATHEMATICAL CORRELATION CRITERIA
- COMPUTER MODELS VALIDATED IN NEUTRAL BUOYANCY AND KC-135
- LARGE DATA BASE OF SIMULATION RESULTS

EASE AS AN EXAMPLE OF GUIDING PRINCIPLES

- OBJECTIVE IS TO CALIBRATE LEARNING AND PRODUCTIVITY
- MUST BE PERFORMED IN ZERO GRAVITY
- EVOLUTION FROM "POOL" AND NEUTRAL BUOYANCY EXPERIENCE, WITH CORRELATION TO BODY DYNAMICS WITH AND WITHOUT WATER DRAG

MID-DECK EXPERIMENTS

- ZERO GRAVITY FLUID-DYNAMIC STRUCTURAL INTERACTION IN PARTIALLY FILLED TANKS
- DYNAMICS AND DAMPING IN MULTI-ELEMENT JOINTED STRUCTURE

FEATURES OF MID-DECK EXPERIMENTS

- STORED IN LOCKER FOR ASCENT AND ENTRY
- MINIMAL POWER FROM OUTLETS
- NO INTERFACE WITH SHUTTLE DPS
- AUTONOMOUS ANALOG TAPE RECORDING OF DATA

PROPOSED STEP EXPERIMENTS

- DAMPING AND DYNAMICS IN A MULTI-ELEMENT TRUSS
- CLEAR NEED - FUNDAMENTAL CHANGE EXPECTED IN THE BEHAVIOR OF JOINTED ASSEMBLIES IN THE PRESENCE AND ABSENCE OF GRAVITY
- CLEAR EVOLUTION -
 - BENCH TESTS AT MIT
 - LOFTING TESTS AT MIT
 - MID-DECK EXPERIMENT
 - STEP EXPERIMENT
- ONGOING DEVELOPMENT OF ANALYTIC TOOLS TO CORRELATE NONLINEAR CONTACT DYNAMICS IN JOINTS

COPE PAYLOAD CONCEPT

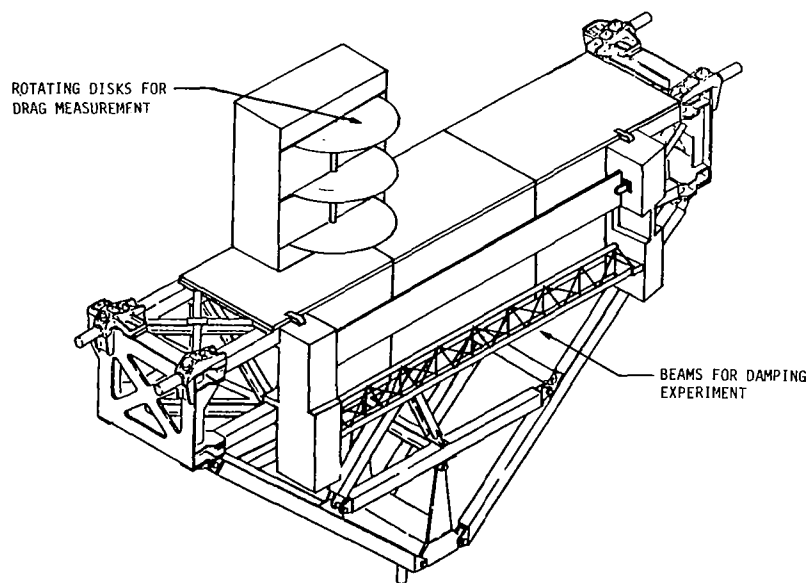

DATA COLLECTION OPTIONS

- REQUIREMENTS: 6 CHANNELS AT 12 BITS
AND 1 KH = 72,000 BAND
- RUNS OF 10 SEC MUST BE STORED (90 K BYTES)
OR TELEMETERED
- OPTIONS: SHUTTLE DPS
STEP RECORDER
LOCAL DIGITAL MEMORY
- SHUTTLE CAMERAS NOT VERY USEFUL

LESSONS LEARNED

- AVOID SHUTTLE DPS (DATA PROCESSING SYSTEM)
AT ALL COSTS
- POWER AVAILABLE IN REASONABLE QUANTITIES
- COMMAND VERY LIMITED
- PAYLOAD INTEGRATION EVEN MORE DIFFICULT
THAN YOU CAN IMAGINE
- REAL WORLD

MEASUREMENT OF PASSIVE MATERIAL DAMPING USING STEP

Don Edberg
Department of Aeronautics and Astronautics
Stanford University
Stanford, California

For a structure orbiting the Earth, we find the following disturbances: magnetic torque, solar radiation pressure, aerodynamic forces and moments, meteorite impact, gravity gradient, and temperature gradient. All these are time dependent in general.

The dynamics and the control of any structure require a knowledge of physical properties. The mass and stiffness are "easy" to measure by static testing; however, material (internal) damping is much more difficult to obtain. It requires dynamic testing, which can introduce many sources of error: air damping and loose trailing wires, both of which mask the effects we wish to measure. The best solution to this problem is to test in zero gravity free-fall where there is no atmosphere, i.e., as in the Space Shuttle.

The system equation for a simple second-order system is:

$$M\ddot{x} + C\dot{x} + Kx = F(t)$$

Figure 1 shows the system time response due to a step input. By proper signal processing, we can get a plot like the one shown in Figure 2. The height of the "peak" is inversely related to the damping C of the system.

To do this properly, we want no other disturbances (such as Shuttle altitude control jets firing). Also, if clamped to the Shuttle, we must be very careful when we account for the Shuttle's mass and inertia. The obvious way to eliminate both these problems is to test a free-flying model. To do this, we attach a small radio transmitter to telemeter strain or acceleration data back to a recording unit. Figure 3 shows a possible transducer hookup that will broadcast the data that we are interested in. A possible layout of an experiment on STEP is shown in Figure 4.

We can see that mass and power consumption would be very small. The only question is how to recover the free-flying models! The Shuttle arm could be used, or the method shown in Figure 5 could also be a possibility.

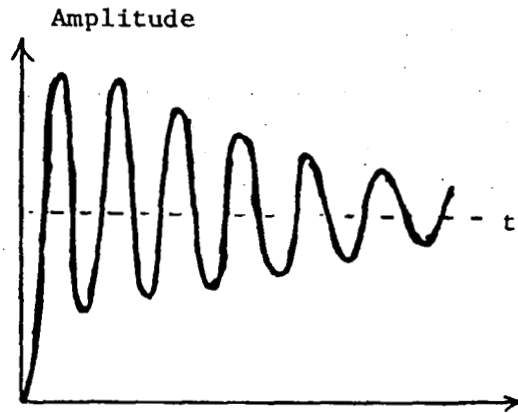

Figure 1.- Time response of a second-order system to a step input.

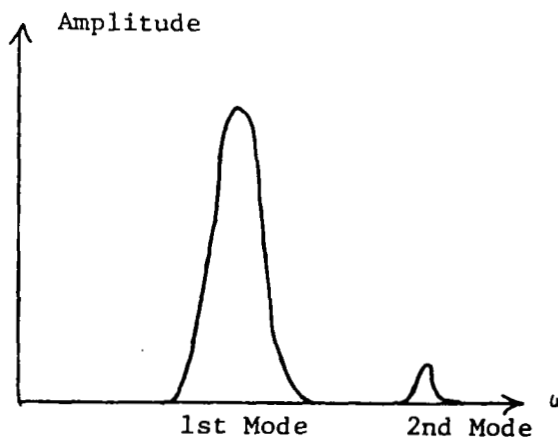

Figure 2.- Response of a system in the frequency domain.

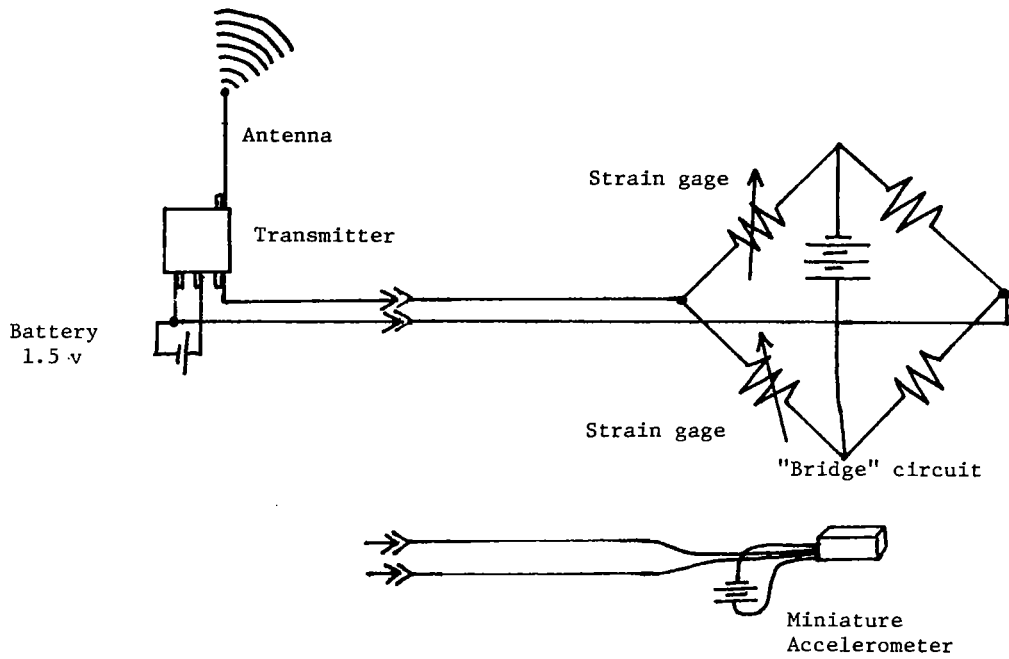

Figure 3.- Transducer and telemetry hookup.

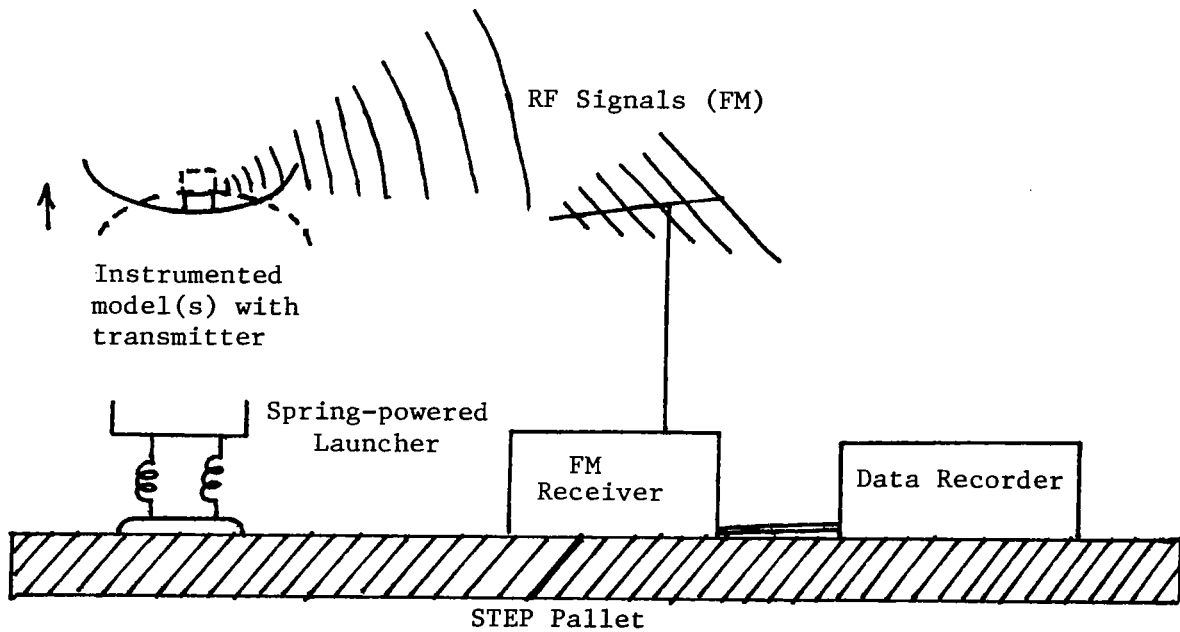

Figure 4.- STEP experimental setup.

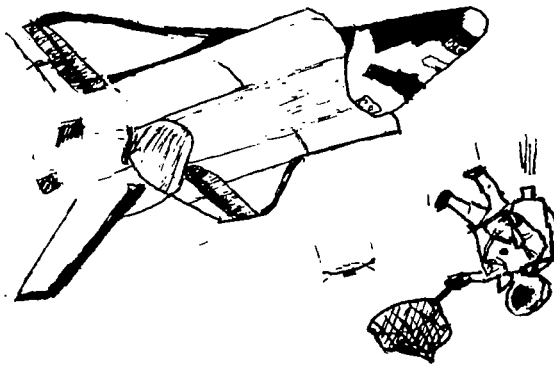

Figure 5.- Model recovery using astronaut EVA.

THERMAL ENERGY MANAGEMENT
PROCESS EXPERIMENT

S. Ollendorf
NASA Goddard Space Flight Center
Greenbelt, Maryland

THERMAL ENERGY MANAGEMENT PROCESSES EXPERIMENT (TEMP)

This experiment will demonstrate that through the use of two-phase flow technology, thermal systems can be significantly enhanced by increasing heat transport capabilities at reduced power consumption while operating within narrow temperature limits. Currently, the heat rejection systems of the orbiter involve the use of single-phase fluid systems. These systems operate over too wide a temperature range (0-40°C), consume large amounts of pump power (500-1000 watts), can only handle rather low flux density loads (1-2 W/cm²), and present difficult integration problems. Presently, two-phase flow systems are ground tested in near-level conditions or with slight adverse tilts to infer 0-g performance. Ground testing is restricted to in-plane orientations due to capillary limits within the liquid distribution systems. Flight testing in space is usually required where out-of-plane design conditions exist, which would be the case for the complex attitude positions of a space station. In addition, it has been noted that such phenomena as excess fluid puddling, priming, stratification, and surface tension effects all tend to mask the performance of two-phase flow systems in a 1-g field. The approach would be to attach the experiment to an appropriate mounting surface with a 15- to 20-meter effective length and provide a heat input and output station in the form of heaters and a radiator. Using environmental data, the size, location, and orientation of the experiment can be optimized. The approach would be to provide a self-contained panel and mount it to the STEP through a frame. It would be insulated on the inboard side and thus would not interact with the other payloads. A small electronics package would be developed to interface with the STEP avionics for command and data handling. During the flight, heaters on the evaporator will be exercised to determine performance. Flight data will be evaluated against the ground tests to determine any anomalous behavior.

ADVANTAGES

- NO MOVING PARTS
- HIGH DENSITY HEAT FLUX AND TRANSPORT
- ACCOMMODATES HEAT SOURCES AND SINKS

ZERO-G OBJECTIVES

- PRIMING OF PUMPS
- LIQUID DISTRIBUTION
- TRANSPORT CAPABILITY

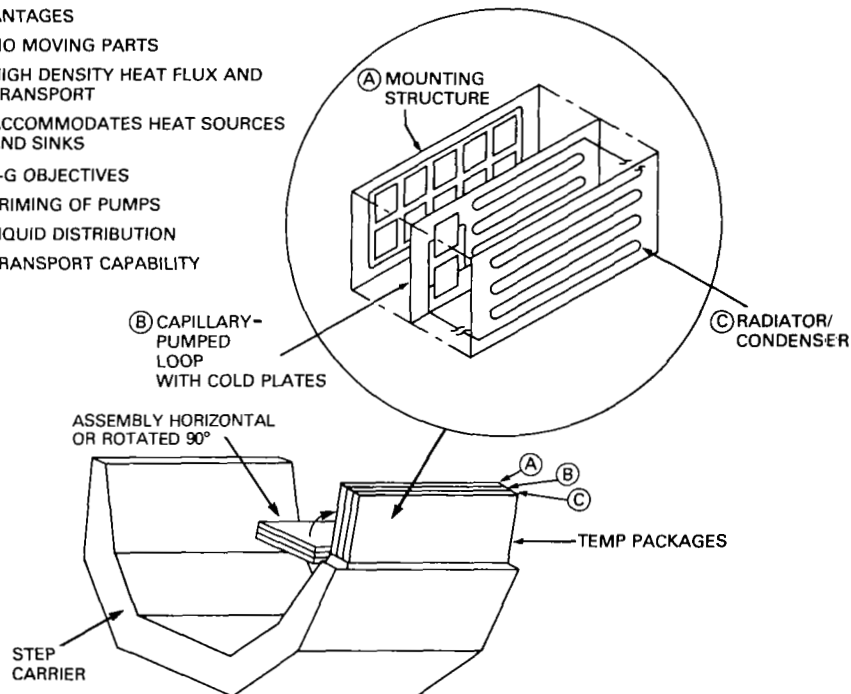

CAPILLARY-PUMPED LOOP SCHEMATIC

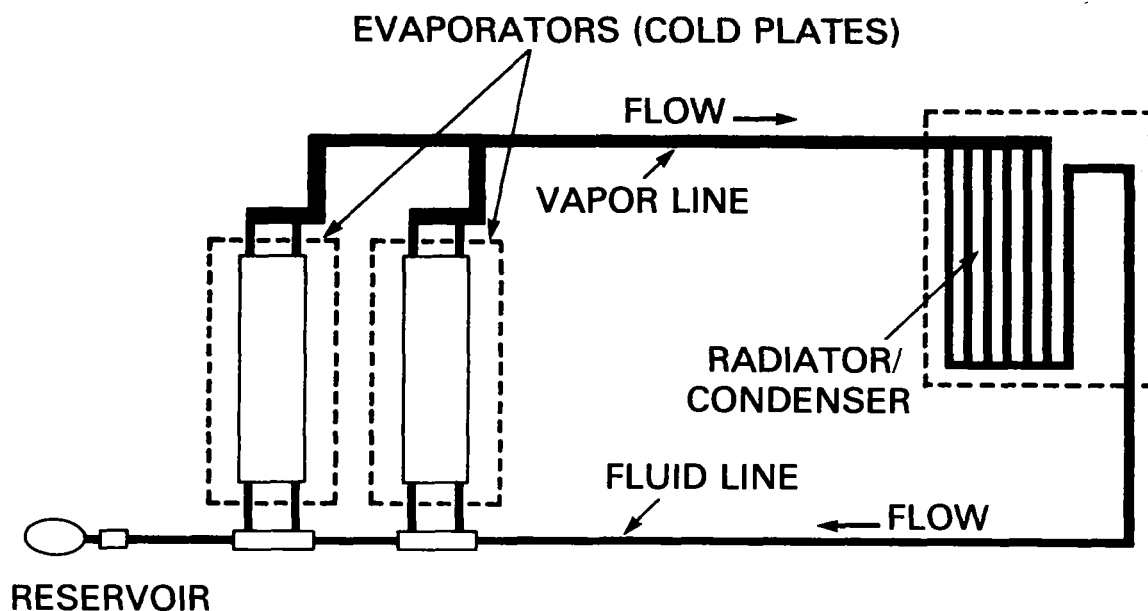

THERMAL ENERGY MANAGEMENT PROCESSES EXPERIMENT (TEMP) REQUIREMENTS

WEIGHT:	50 kg
ENVELOPE:	3 M × 1.25 M × .5 M
POWER:	500 WATTS AVERAGE, 10 HRS DURATION @3 TIMES PER MISSION 1-2 kW PEAK, ½-TO 1-HR DURATION @2 TIMES PER MISSION
DATA:	50 DIGITAL, 2 kBS, STORED ON TAPE SELECTED CHANNELS (10) BY TELEMETRY
COMMANDS:	50 DIGITAL, 40 STORED, 10 BY CREW ACTIVATION
ANCILLARY DATA:	STATE VECTORS AFTER FLIGHT
SPECIAL NEEDS:	<ul style="list-style-type: none">● RADIATOR HORIZONTAL OR ROTATED TO GIVE GOOD VIEW TO SPACE● EXTREME STS THERMAL ENVIRONMENTS DESIRABLE

CANADIAN ATTITUDE SENSING
EXPERIMENTAL PACKAGE
(CASEP)

A.H. Reynaud
Space Technology and Applications Branch
Communications Research Centre
Department of Communications
Ottawa, Canada

1. Introduction and CASS/CASEP Objectives

A principal program objective of the Canadian Department of Communications (DOC) Space Technology and Applications Branch is to develop the technology required for future Canadian spacecraft through a combination of in-house R&D and industrial contracts. The control of large and flexible spacecraft with large narrow-beam antennas has been identified to be a critical technology, and attitude sensors to be a key area requiring hardware development. In order to meet these requirements, program approval has been given for the Project Definition Phase in the development of a Canadian Attitude Sensing Subsystem (CASS). Reference Spacecraft Missions for developing the requirements for this integrated sensing package are the current RADARSAT and MSAT programs.

RADARSAT is a Canadian Department of Energy Mines and Resources surveillance satellite which is planned to be launched in the early 1990's into a low-Earth (1000 km) nearly polar orbit. The currently proposed design would include a relatively large reflector to support the synthetic aperture radar and requires relatively precise attitude determination and control to support this and other, as yet to be determined, sensor payloads. RADARSAT is described in more detail in another presentation (ref. 1).

MSAT is a Canadian Department of Communications Mobile Communications Satellite operating at 800 MHz and providing two-way communication to mobile systems in vehicles. A demonstration MSAT spacecraft, currently in Project Definition Phase, is planned to be launched in the late 1980's into a standard geostationary orbit. The satellite is expected to include dual 9-meter antenna reflectors. A large commercial or operational spacecraft is projected for the early 1990's and is envisioned to have an antenna reflector in the 30-50 meter diameter range. It would require control of the narrow RF beams to accuracies of about 0.05° . Discussions are currently under way with NASA to make MSAT a joint DOC-NASA program.

The Canadian Attitude Sensing Experiment Package (CASEP) is designated as an experimental version of CASS. STEP is seen as an excellent opportunity to demonstrate or qualify a control subsystem such as CASS. STEP provides the space environment, such as zero gravity, no atmospheric optical diffusion, accurate star field, realistic orbital conditions, etc., which is critical in verifying the performance of control system components. It is generally considered that space qualification of a major control subsystem, such as CASS, is essential prior to committing to its use in a prime mode for a long duration mission, because it is recognized that control system failures can be catastrophic and costly to the mission. Therefore, we strongly support the general goals of STEP and solicit the consideration of CASEP as a potential experiment on STEP.

The CASS and CASEP objectives are summarized in Figure 1.

OBJECTIVES

CANADIAN ATTITUDE SENSING SUBSYSTEM (CASS)

- TO DEVELOP AN INTEGRATED ATTITUDE SENSING SUBSYSTEM FOR THE NEXT GENERATION OF LARGE ANTENNA (NARROW BEAM) SPACECRAFT
 - LOW EARTH ORBIT (RADARSAT)
 - GEOSTATIONARY ORBIT (MSAT)

STEP EXPERIMENT :

- TO DEMONSTRATE / VERIFY THE OPERATION OF THIS MISSION CRITICAL PRIMARY ATTITUDE SENSOR PRIOR TO COMMITTING TO ITS USE ON AN OPERATIONAL MISSION

Figure 1

2. CASS Design Features

The development of an integrated attitude sensing subsystem is a logical progression of our analytical studies and current component development on rate gyros, accelerometers, star sensors, space microprocessors, etc. The major design features or goals are listed in Figure 2. An integrated system will permit the designer to select, trade off and combine the best features of relatively conventional components to obtain enhanced overall subsystem performance. It permits, for example, a trade-off between gyro drift rate and star sensor update period.

The multimission capability provides for application on different missions, including LEO and GEO, without redevelopment or requalification of the package. It is expected that only software changes and physical reorientation on the spacecraft would be required for each application.

- OPTIMIZED COMBINATION OF "STATE-OF-ART" COMPONENTS
- DISTRIBUTED OR CENTRALIZED ELEMENTS, OPTIONALLY
- INTERMEDIATE ACCURACY
 - BETWEEN EARTH SENSORS AND HIGH ACCURACY STAR SENSORS
- LOW COST, WEIGHT, POWER
- MULTIMISSION
- RELIABLE
 - SELF CHECKING
 - FAULT TOLERANT
- CONTROL SYSTEM ATTITUDE SENSOR OR PAYLOAD ATTITUDE DATA

Figure 2

3. CASS/CASEP Block Diagram

Figure 3 provides a very simplified diagram of the current CASS concept. The key elements are:

- i) A rate gyro package, nominally three two-axis tuned rotor gyros with pulse rebalance electronics
- ii) A star sensor, with one or two optical axes and based on charge transfer devices
- iii) A Multi-Microprocessor system to process sensor data, detect failures and manage external serial communications
- iv) Accelerometers (optional) for distributed sensing and control of flexible structures
- v) Sun sensor (optional) for initializing system and for backup fault tolerance

The basic outputs are attitude angles and rates (TBD accuracy) which can be used either to control the spacecraft attitude, as in the MSAT case, or to be collated with payload data for ground processing, as in the case of RADARSAT or a special payload on a large platform like the space station.

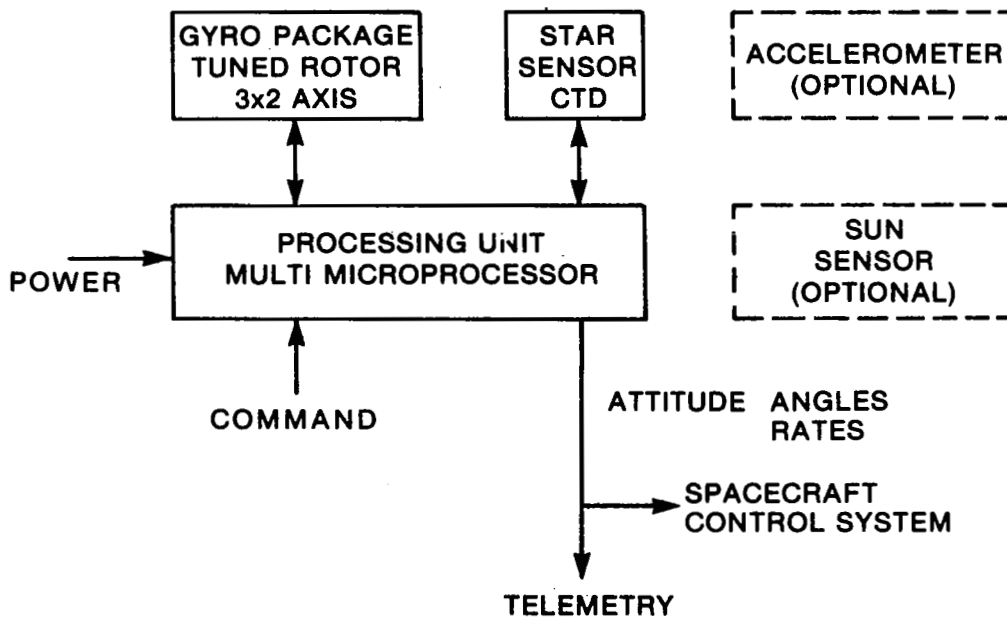

Figure 3

4. Proposed Development Schedule

Figure 4 provides a tentative schedule for DACC/CASEP with the interfaces with the STEP program highlighted. The projected STEP opportunities coincide conveniently with the CASS program, which is currently driven by a potential mission application in the early 1990's.

The first inverted triangle in April 1984 indicates when a baseline description of CASS would be available and when a decision would be made as to whether CASEP on STEP would be considered to be a feasible experiment. The second triangle indicates that a flight-qualified subsystem would be available in 1988 and there would be an "optimum window" for STEP for about 18 months in 1988/89 (shown as cross-hatched bar). Although considered undesirable at this time, consideration could also be given to using a "refurbished" engineering model to fly at an earlier date.

Overall project activities that are currently under way or have received program approval are indicated by shaded bars. The Directorate of Space Mechanics is currently developing and upgrading its Control Systems Laboratory at the Communications Research Centre for the testing and evaluation of proposed components and the CASS subsystem.

It is noted that the feasibility of flying CASEP as an experimental package on the Demonstration MSAT in 1988 will be investigated in the PDP Phase.

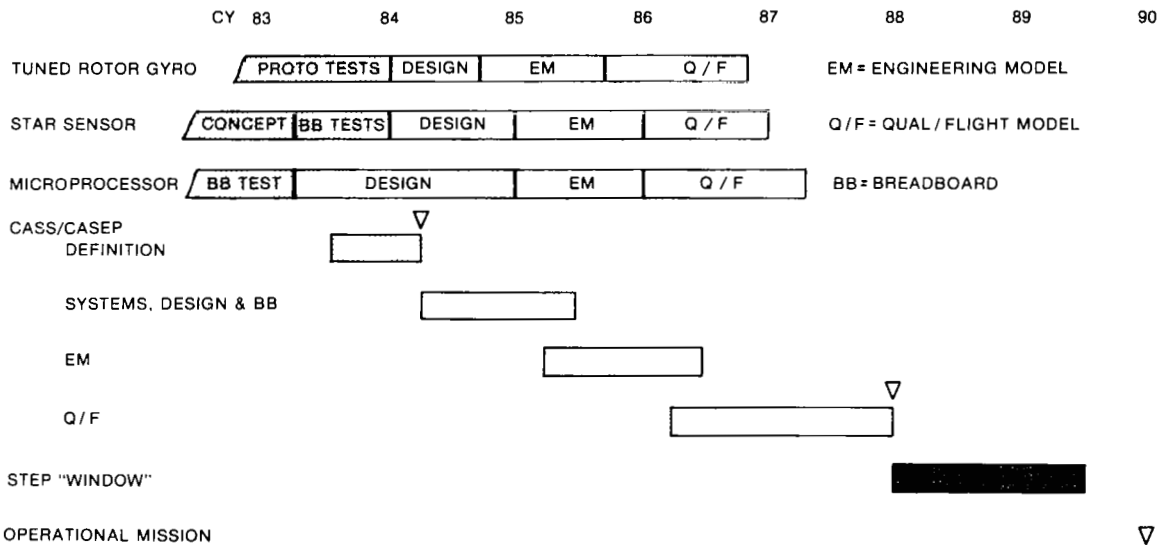

Figure 4

5. CASS Project Definition Phase (PDP)

The contractor proposals for the PDP have been reviewed and it is anticipated that a contract will be awarded in the fall of 1983 and completed in March 1984. In addition to the standard PDP activities and trade-offs identified in Figure 5, a major task has been included to define CASS as an off-line experimental package (i.e. CASEP).

At the conclusion of the PDP, a program decision will be required to determine whether to proceed to the CASS hardware development phases. It will also be necessary to determine whether to continue to support development of specific components or to procure "off-the-shelf" units.

- **CONTRACT START JULY 83**
- **COMPLETION MARCH 84**
- **TASK SUMMARY**
 - **SYSTEM REQUIREMENTS**
 - **EXPERIMENTAL PACKAGE REQUIREMENTS**
 - **PROCESSOR REQUIREMENTS**
 - **STAR SENSOR REQUIREMENTS**
 - **GYRO REQUIREMENTS**
 - **CASS PACKAGING**
 - **SPECIFICATIONS**
- **DECISION TO PROCEED TO DEVELOPMENT PHASE APRIL 84**
- **DECISION ON COMPONENT DEVELOPMENT APRIL 84**

Figure 5

6. Mission Requirements

Figure 6 outlines the currently perceived mission requirements. A major goal of the experiment on STEP is to experience a maximum amount of operating time exposed to the space environment. It is therefore desirable to power up the package at the start of the mission and leave it on until the conclusion of the mission. It would also be desirable to select at least three data collection periods at the beginning, middle and end of the mission. This would permit assessment of performance variations with time, temperature, etc.

Specific orbit and attitude requirements are not seen as critical for CASEP; however, their approximate values are required a priori in order to preprogram the star catalog and to select suitable data collection windows (i.e., with Sun or Earth not in FOV, or when platform is experiencing "interesting transient attitude conditions").

The method used to verify the absolute performance of CASEP remains an open issue. For that reason, it is requested that precise attitude determination of the STEP be provided and be available to collate with our experimental data.

OPERATION SCENARIO:

- TURN PACKAGE ON AS SOON AS POSSIBLE
AND LEAVE ON FOR TOTAL MISSION
- SELECT ACCEPTABLE TEST / DATA COLLECTION WINDOWS

ALTITUDE / INCLINATION / ECCENTRICITY :

- NOT CRITICAL; ORBIT PARAMETERS MUST BE KNOWN
A PRIORI TO SET STAR CATALOGUE

ATTITUDE POINTING & STABILIZATION :

- ABSOLUTE VALUES NOT CRITICAL
- REQUIRE APPROX ATTITUDE TIMELINE A PRIORI
- REQUEST ACTUAL STEP ATTITUDE DATA BE KNOWN
(TBD ACCURACY) AND RECORDED WITH TEST DATA

ATTITUDE CONSTRAINTS :

- SUN / EARTH / REFLECTIONS NOT IN
STAR SENSOR FOV DURING DATA COLLECT
- BUILT-IN SUN PROTECTION

Figure 6

7. Physical Requirements

Figure 7 includes a physical envelope for CASEP. The package is relatively compact and lightweight. It is shown here as a single unit; however, it could also be configured as three separate, individually mounted units to facilitate installation in a spacecraft and to provide for the distributed location of sensors. The star sensor baffle may also be partially deployable on orbit to reduce the size of the spacecraft launch configuration, but it would not necessarily be retractable. Although a single star sensor boresight is indicated, a dual canted boresight configuration is being investigated.

An unobstructed FOV is a requirement. It is shown nominally parallel to the orbiter yaw axis, but could be directed along another vector line if there is an overriding mission driver.

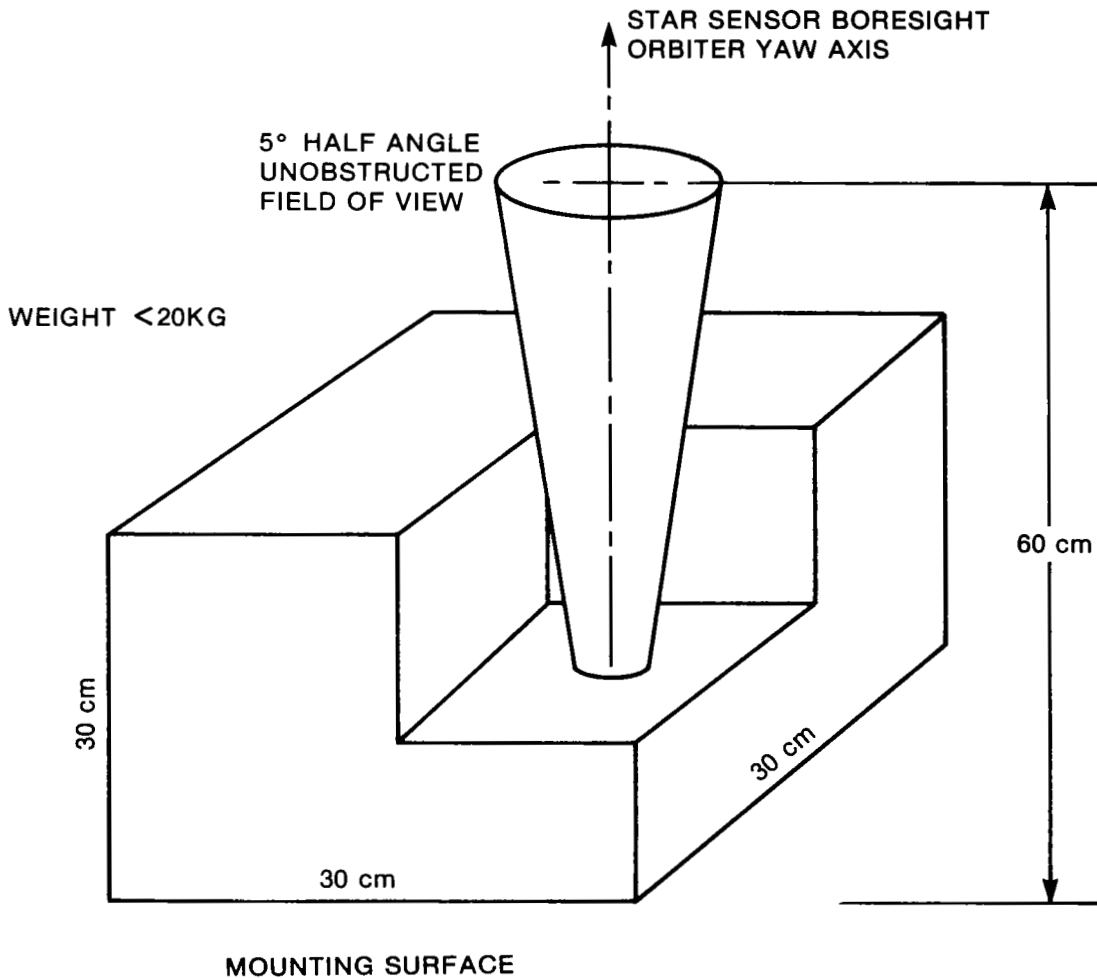

Figure 7

8. Support Requirements

The anticipated power requirements are listed in Figure 8 and are relatively standard. The peak power is required during gyro run-up. No pyrotechnic or explosive devices are required.

The commands listed in Figure 8 must be considered preliminary at this time. It will be necessary to initialize the ephemeris data routine in the Star Sensor processor. It is highly unlikely that there would be a requirement to upload the star catalog from the ground, because of the quantity of command data and the complexity of its verification.

POWER :

- 28 VOLTS DC
- 25 WATTS AVERAGE
- 50 WATTS PEAK
- AUTONOMOUS HEATERS

COMMANDS :

- ON/OFF
- INITIALIZE EPHEMERIS DATA
- SELECT DATA MODE (OPTION)
- LOAD STAR CATALOG (UNLIKELY OPTION)

DATA :

- SEE NEXT FIGURE

Figure 8

9. Data Telemetry/Recording Requirements

Figure 9 tabulates the consensus of data requirements. They have been classified into four categories.

- i) Burst Mode is a high data rate to allow examination of the internal operation of the system.
- ii) Transient Mode allows sampling all output parameters approximately once per second, for example, during relatively rapid orbiter maneuvers.
- iii) Normal Mode would provide a complete set of data every minute and would be adequate for most of the test run periods.
- iv) Quiescent Mode would provide data to monitor the health of the package at all times.

Although real-time telemetry would be attractive, recorded data collated with time, orbit and attitude data would be adequate. The quiescent health data should be provided in real-time to supervise the experiment and to plan contingency activities.

	DATA RATE (12 OR 16 BIT WORDS)	DURATION	REAL TIME TELEMETRY	RECORDED
BURST DATA (OPTION)	300 / SEC	2x15 SEC	DESIRABLE	ACCEPTABLE
TRANSIENT PERFORMANCE	12 / SEC	3x15 MINUTES	DESIRABLE	ACCEPTABLE
NORMAL	12 / MINUTE	3x3 HOURS	DESIRABLE	ACCEPTABLE
QUIESCENT	12 / HOUR	MAX	YES	—

Figure 9

REFERENCE

1. Zimcik, D. G.; Vigeron, F. R.; and Ahmed, S.: Flight Test of a Synthetic Aperture Radar Antenna Using STEP. STEP Experiments Requirements, NASA CP-2294, 1984, pp.339-354.

PHOTOVOLTAIC CONCENTRATOR POINTING DYNAMICS
AND PLASMA INTERACTION STUDY

Theodore G. Stern
General Dynamics Corporation
Convair Division
San Diego, California

OBJECTIVES OF THE EXPERIMENT

Concentrating solar photovoltaic arrays are potentially more efficient and cost-effective than planar arrays due to the reduction in required solar cell area and the ability to use more efficient cells. A significant portion of the mass and cost of a concentrator array arises from the rigid support truss and gimbal mechanism required to meet the more stringent pointing requirements of high concentration ratio systems. Accurate pointing of large planar surfaces has not been required of spacecraft to date. A demonstration of the ability to control such a large structure would help pave the way for concentrator utilization.

The objectives of this experiment are to use the STEP system to demonstrate the viability of concentrator photovoltaic arrays by: (1) configuring a deployable mast on the STEP pallet with concentrator mass models and some active photovoltaic modules, (2) measuring the array pointing dynamics under normal rotation as well as disturbance conditions, (3) performing an array plasma interaction experiment to determine the steady-state plasma losses under various voltage conditions, and (4) providing active distributed control of the support truss to determine the improvement in dynamic response.

- Configure a deployable truss with active & dummy concentrator panels
- Measure the array pointing dynamics under normal & disturbance conditions
- Perform an array plasma interaction experiment at various voltages
- Provide active distributed control to determine the improvement in dynamic response

**Addressing these issues helps enable
the concentrator technology**

APPROACH

The STEP system will be fitted as shown with a deployable/retractable truss upon which the solar concentrator active and dummy panels will be deployed. The dummy panels will provide the distribution of mass needed to simulate the array structural dynamics; the active panels will measure the performance of the concentrator as it is affected by the truss and plasma dynamics. A single gimbal will be needed about the truss axis to provide pointing control for the experiment. The pallet electronics will provide control, sequencing, and instrumentation for both the plasma interaction experiment and the truss dynamics experiments.

STEP CONCENTRATOR EXPERIMENT

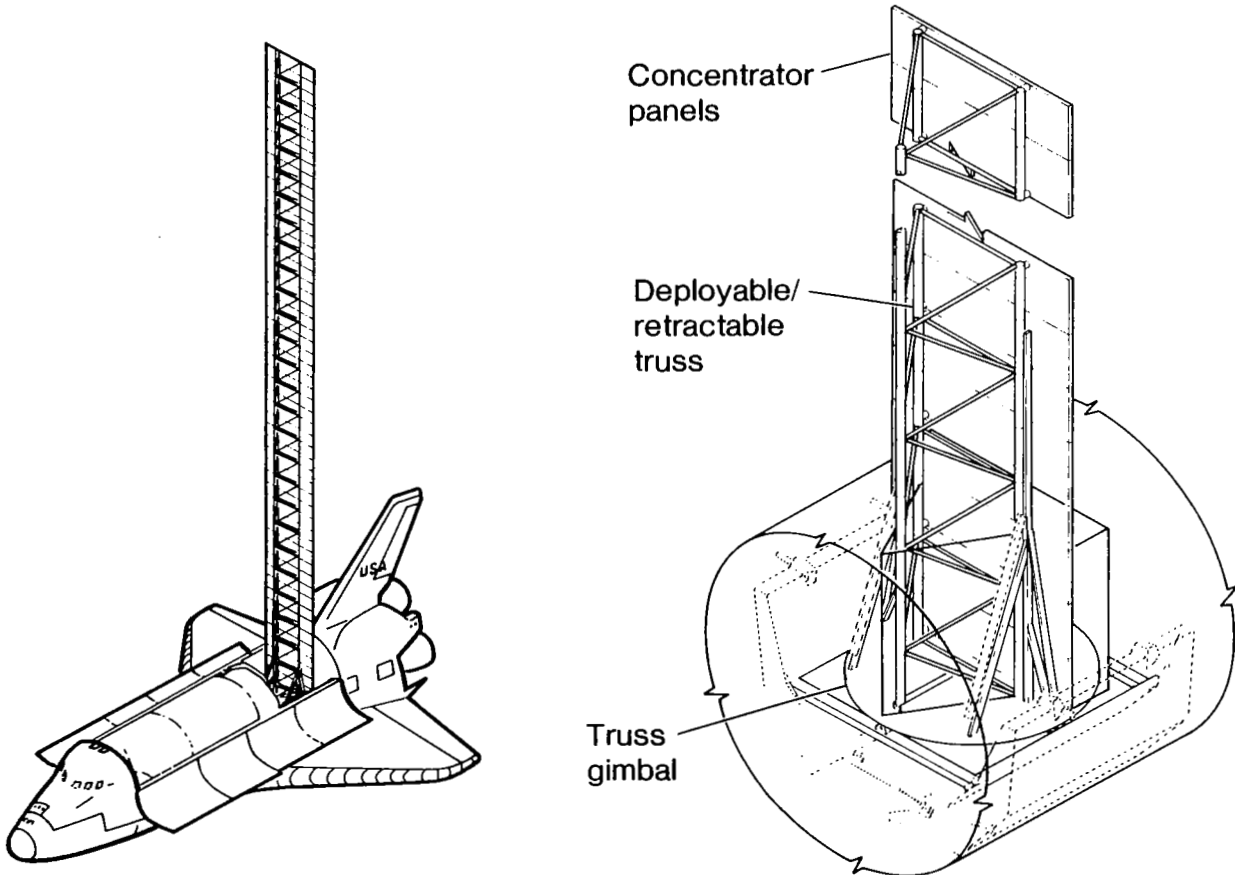

EXPERIMENT CONTROL AND INSTRUMENTATION

The control and instrumentation for the most experiments will be provided by the STEP pallet electronics. The mission control specialist will still have the highest level of control, including the Deploy Truss, Start Test, Emergency Stop, Retract Truss, and Emergency Jettison commands. The STEP pallet will control sequencing of the experiment tasks, including the predetermined choice of array voltage levels and truss input disturbances to be tested. All actions will require arming and safety checks. Interrupt control will be available to the mission specialist who will monitor key points in the experiment. Instrumentation control and data collection will be provided by the pallet.

While it is providing the experiment control, the pallet will periodically monitor the array tracking function to assure proper array pointing into the solar vector. The array tracking can be monitored through the feedback provided by variations in the array output power. This will be coupled with data gathered from the array gimbal motors and orbiter orientation data to provide pointing strategies that will free the microprocessor long enough to conduct the required experiment task actions.

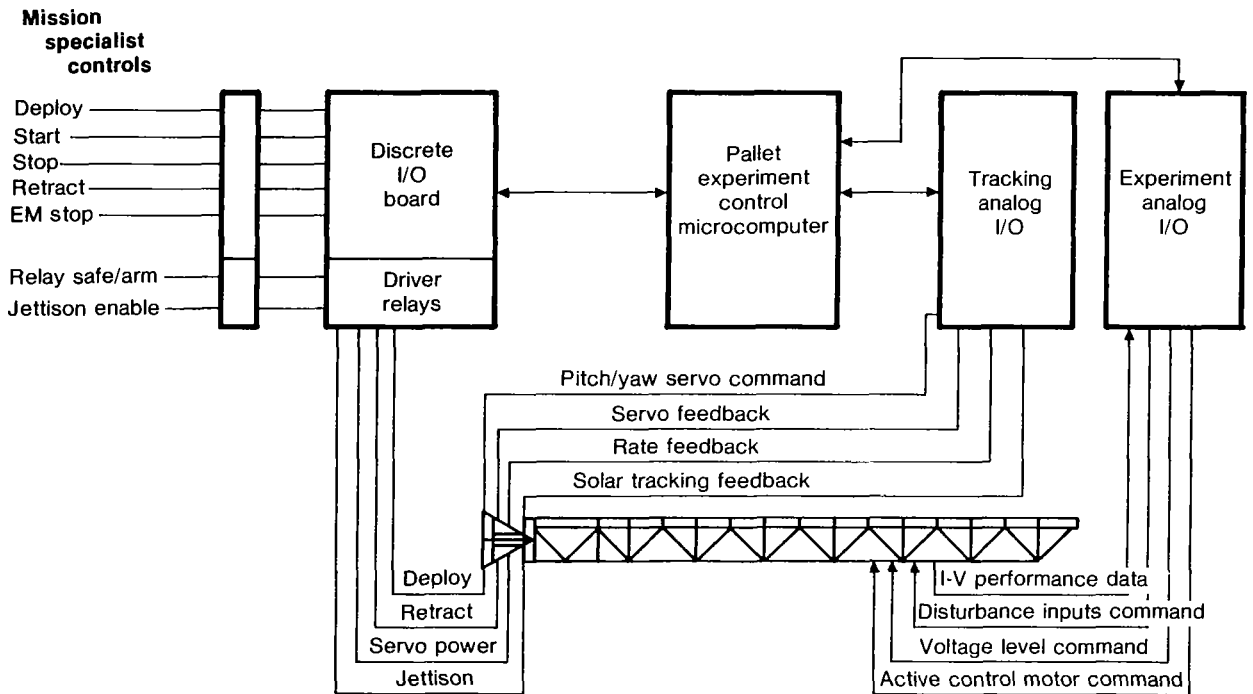

TEST AND EVALUATION FLOW

The test flow will include monitoring of the array dynamics during normal solar acquisition and tracking as well as during induced disturbances. The disturbances could be programmed to simulate a set of events anticipated of space station operation. For the plasma experiment, the parasitic plasma power loss will be determined at various voltages. A determination of voltage limits before arcing, a critical issue for arrays operating at nominal voltages >200 V, would provide valuable data; however, isolation of the accompanying power transients must be assured. To provide a time-correlated reference to synchronize and label the processed and raw data that is collected, the 16 kHz PSK bus is proposed as the provider of time correlation signals. This experiment should have low data rate requirements since the measured dynamic responses are low frequency, the tracking updates can occur over a period of seconds, and plasma test measurements can take minutes. A data rate on the order of 10 KBPS is probably sufficient. The experiment peak power required for active control motors and instrumentation should be less than one kilowatt.

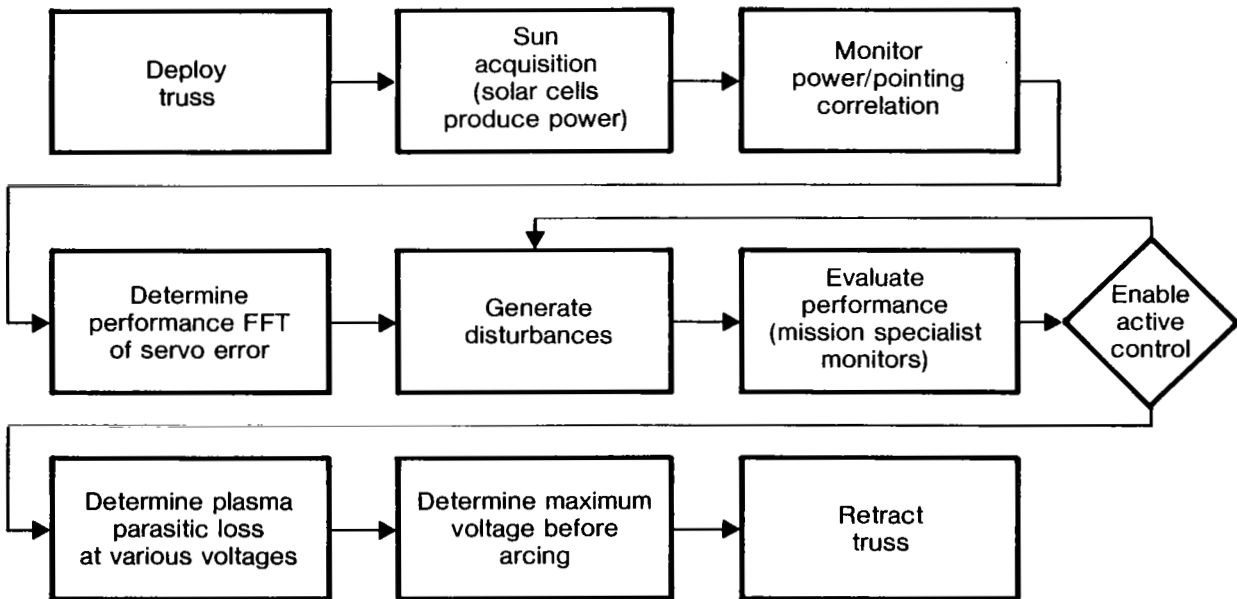

CONCENTRATOR SOLAR ARRAY PLASMA INTERACTION EXPERIMENT OBJECTIVES

Large planar solar arrays are expected to expose a significant portion of their electrical bus connector area directly to the ionized plasma, which is part of the LEO environment. Analysis and some test data indicate that the plasma will act as a resistive shunt causing a power loss. Concentrator systems can be designed with the power bus inherently shielded to a significant degree from the plasma and with their metal mirror substrates at ground potential. This potential advantage of concentrating arrays needs to be explored to determine that the higher achievable voltages do not cause plasma arcing and that plasma loss through unfilled cracks and edges is not a problem. The ability to distribute live modules over larger distances will allow this experiment to augment the SAFE 2 experiment objectives.

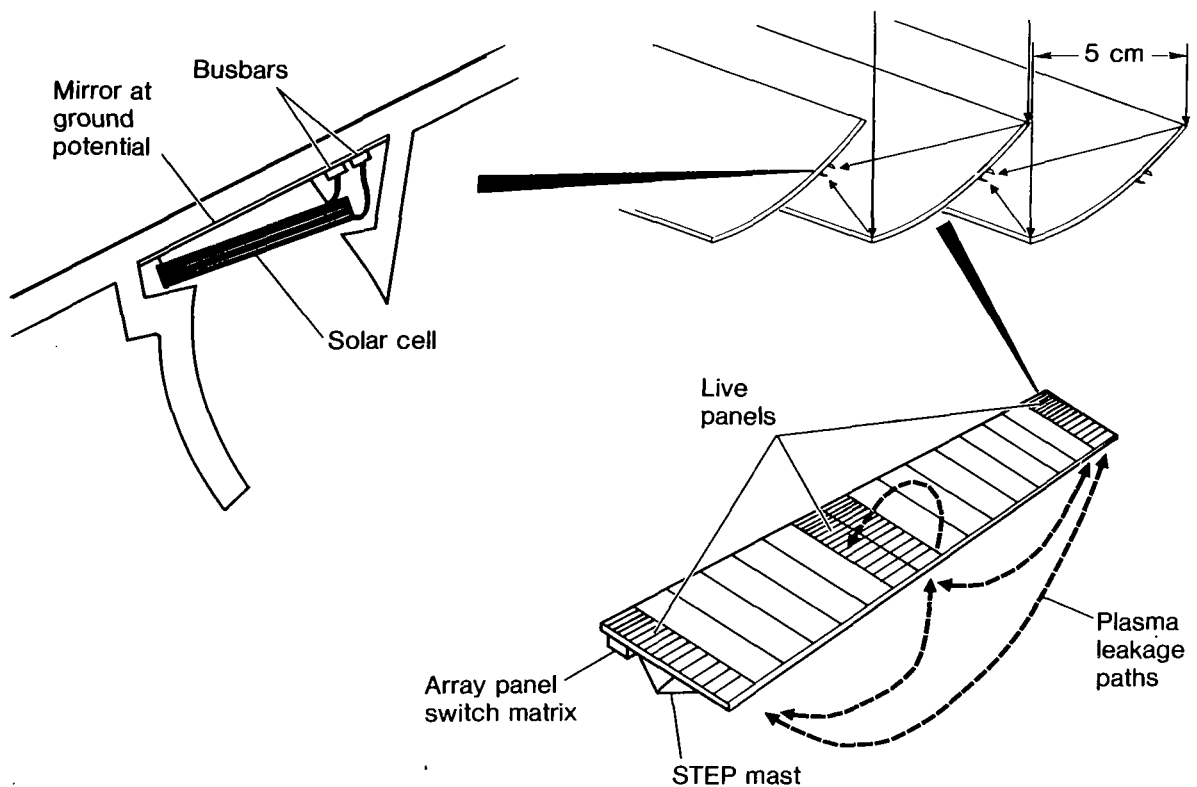

STEP SOLAR ARRAY PLASMA EXPERIMENT CONTROL AND INSTRUMENTATION

The STEP solar array plasma experiment is designed to obtain information about losses caused by direct shunting of array power through the surrounding plasmas. The proposed experiment segments the array into 100 V submodules, which can then be connected in series-parallel arrangements to allow local voltage gradients from 28 V to 400 V/m d.c. Shielded insulated busses together with a switch matrix will provide the various interconnections, while the analog I/O section monitors voltages and currents.

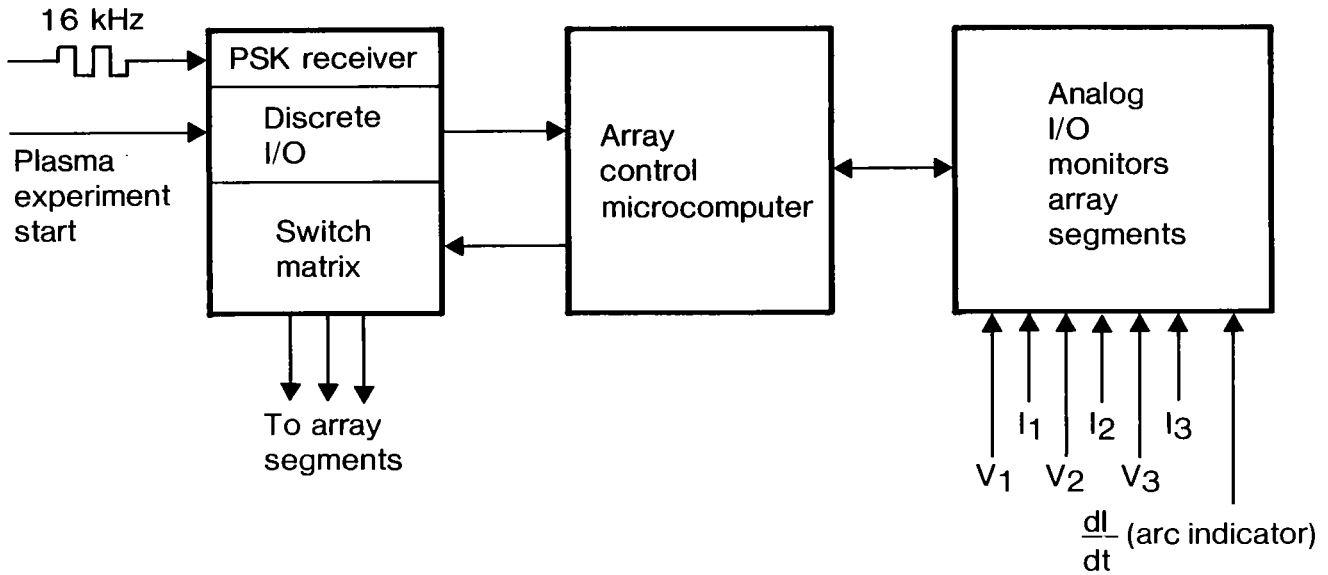

CONCLUSIONS

The issues of large array pointing dynamics and plasma interactions must be addressed to advance the technology of solar concentrators. Ground-based testing cannot adequately simulate a low-g and plasma environment for large arrays. A STEP experiment has been proposed that will measure the dynamics of a truss-backed array under normal and disturbance conditions, and it will measure plasma interaction effects at various voltages. The experiment will provide the data necessary to implement solar concentrators in the near future by determining the dynamic stability and pointing accuracy of large arrays and their maximum voltage of operation.

- Ground facilities cannot adequately simulate the space environment to qualify new solar array technology
- Tests in space are needed to demonstrate dynamic & plasma interactions with large arrays
- The STEP experiment can provide data needed to enable the concentrator technology

Achieving the reduced cost of solar concentrators is a tangible benefit of the STEP program

LOW CONCENTRATION RATIO SOLAR ARRAY
STRUCTURAL CONFIGURATION

S.J. Nalbandian
Rockwell International Corporation
Shuttle Integration and Satellite Systems Division
Seal Beach, California

LOW CONCENTRATION RATIO SOLAR ARRAY ADVANTAGES

Rockwell has investigated a number of concentrating array concepts including a high concentration ratio (500 suns) cassegrainian concentrator using gallium arsenide (GaAs) solar cells for a multi-threat hardness applications. Solar cells and a brassboard concentrator element were experimentally evaluated. The study showed the advantages of the GaAs cells (high temperature capability and more radiation resistance) and the cassegrainian geometry from the standpoint of threat survival. However, the sophisticated optics and the heat pipe required for cell cooling did not lend themselves well to low cost, light weight, or a large area array design. The figure illustrates the higher degree of pointing accuracy needed for high concentration ratio (CR) solar arrays. A study performed for NASA MSFC (ref. 1) evaluated planar, low concentration (CR=2 to 6) and cassegrainian (CR=20) array configurations which indicated that a low concentration array (CR=6) would be most cost-effective. The essence of the argument is that, beyond a concentration ratio of six or so, little further reduction in cell cost is achieved. On the other hand, increased concentration makes the design optics, cell cooling methods, and structure more difficult and expensive so that the overall cost of power increases rather than decreases as illustrated in the figure. A contract was awarded by NASA MSFC in June 1981 (ref. 2) to perform a preliminary design of a multi-100 kW low concentration ratio solar array.

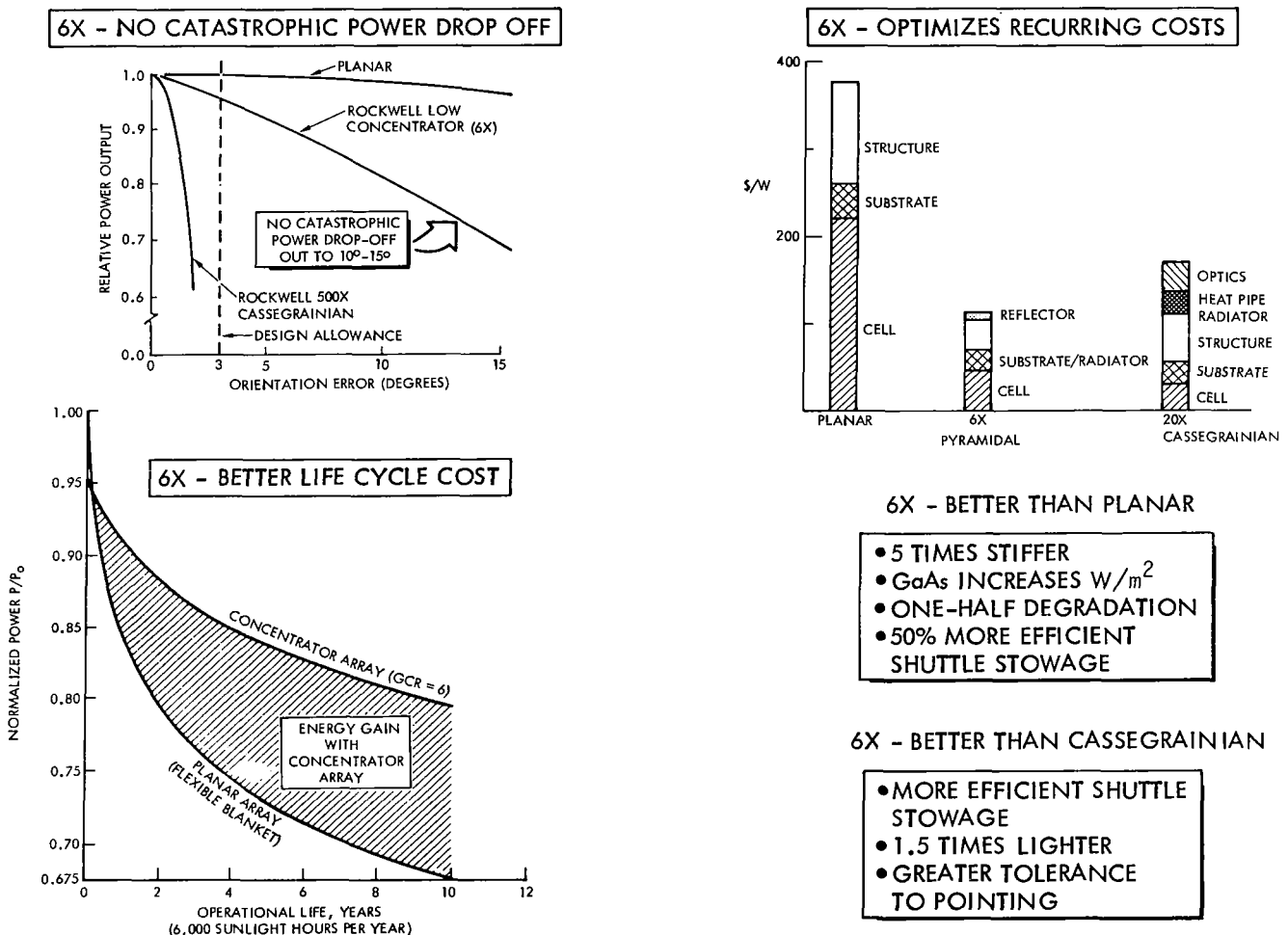

Figure 1

**LOW CONCENTRATION RATIO SOLAR ARRAY PROJECT OBJECTIVES AND
GROUND RULES (NASA MSFC CONTRACT NAS8-34214)**

A large-area array, with a geometric CR of six suns, has been selected as a relatively low risk development to demonstrate technology readiness by the end of 1984. This program has, as its prime objective, the preliminary design of a concentrator solar array system capable of providing in excess of 300 kW power, deliverable to the user system in low Earth orbit by a single Shuttle launch. Up to four solar array modules (113 kW each using silicon (Si) solar cells and 175 kW each using GaAs solar cells) would comprise the array depending upon application requirements. The preliminary design effort, including critical technology (hardware) demonstrations, was completed in June 1983. The concentrator array design provides for utilization of either Si or GaAs solar cells for conversion of solar energy to electrical power. This figure lists the more significant objectives and ground rules considered for the program.

OBJECTIVES

- TO PERFORM A PRELIMINARY DESIGN OF A LOW CONCENTRATION RATIO (CR = 2-6) SOLAR ARRAY FOR MULTI- 100 kW (300 kW-1000 kW) LOW EARTH ORBIT APPLICATION HAVING A LOW RECURRING COST WITH A 1984 TECHNOLOGY READINESS DATE
- DESIGN, FAB, TEST SUBELEMENTS/COMPONENTS TO SUPPORT PRELIMINARY DESIGN
- IDENTIFY TECHNOLOGY DEFICIENT AREA AND SCOPE TASKS FOR RESOLUTION
- GENERATE COST & SCHEDULE FOR GROUND TEST MODULE

PRELIMINARY DESIGN EFFORT
COMPLETED JUNE 1983

GROUND RULES

- CONCENTRATION RATIO (CR) - 2 TO 6
- FOUR-SIDED CONCENTRATOR MODULE APPROACH
- TARGETED FOR \$30/WATT RECURRING (1978 DOLLARS)
- USE 1984 TECHNOLOGY READINESS DATE
- DESIGN FOR LOW EARTH ORBIT (LEO) APPLICATION
- DESIGN SHOULD BE CONSISTENT WITH BOTH SILICON AND GaAs CELLS
- STOWAGE METHOD SHOULD BE FOLD-UP
- DESIGN SHOULD PROVIDE MAXIMUM kW PER SHUTTLE LAUNCH CONSISTENT WITH OTHER GUIDELINES
- WATTS/kg GOAL NOT SPECIFIED BUT TO BE GOVERNED BY TRANSPORTATION COST PENALTIES AND REASONABLE EXTENSION OF STATE OF THE ART
- PRACTICAL CONFIGURATIONS COMPATIBLE WITH ORBITER CARGO COMPARTMENT AND ON-ORBIT MAINTENANCE OPERATIONS
- RATING OF 300 KW TO 1000 KW

MAJOR DESIGN DETERMINANTS

Figure 2

LOW CONCENTRATION RATIO SOLAR ARRAY MODULE DEPLOYMENT CONCEPT

This figure illustrates the deployment concept and nomenclature adopted for the concentrator array. The assembled module consists of six interconnected containers which are compactly stowed in a volume of 3.24 m^3 for delivery to orbit by the Shuttle. The containers deploy in accordian fashion into a rectangular area of 19.4×68 meters and can be attached to the user spacecraft along the longitudinal centerline of the end container housing. Five rotary incremental actuators requiring about 8 watts each will execute the 180-degree rotation at each joint. Total time for this maneuver is less than 30 minutes. Deployable masts (three per side) are used to extend endcaps from the housing in both directions. Each direction is extended by three masts requiring about 780 watts for about 27 minutes. Concentrator elements are extended by the endcaps and are supported by cable systems that are connected between the housings and endcaps. These power generating elements contain reflector panels which concentrate light onto the solar panels consisting of an aluminum radiator with solar cells positioned within the element base formed by the reflectors. A flat wire harness collects the power output of individual elements for transfer to the module container housing harnesses.

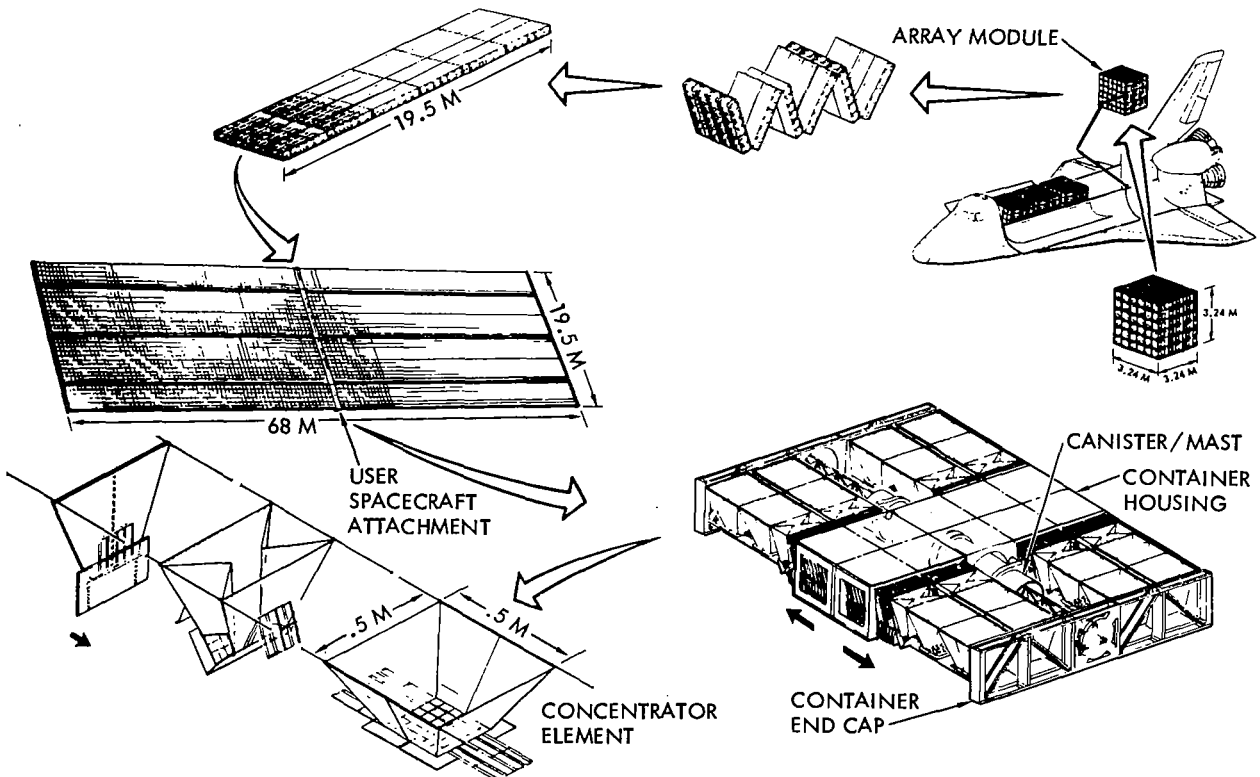

Figure 3

BASELINE ARRAY CONTAINER STRUCTURES/MECHANISMS/SUBSYSTEMS

Two container configurations are used to form the array module, one with deployable masts and one without. Thus, the design is modular and can be made up of one container with masts or combinations of a container with masts and one without. The figure illustrates the major components which comprise a typical container having deployable masts. Launch support tubes in the housing provide support to concentrator elements when stowed. As the concentrator elements are extended by movement of the end cap, they are supported by cables played out under constant tension by the cable extension mechanisms contained in the housing. The last concentrator element in each row is connected to the housing by concentrator stack translation mechanisms which will allow for thermal growth or on-orbit stationkeeping deflections.

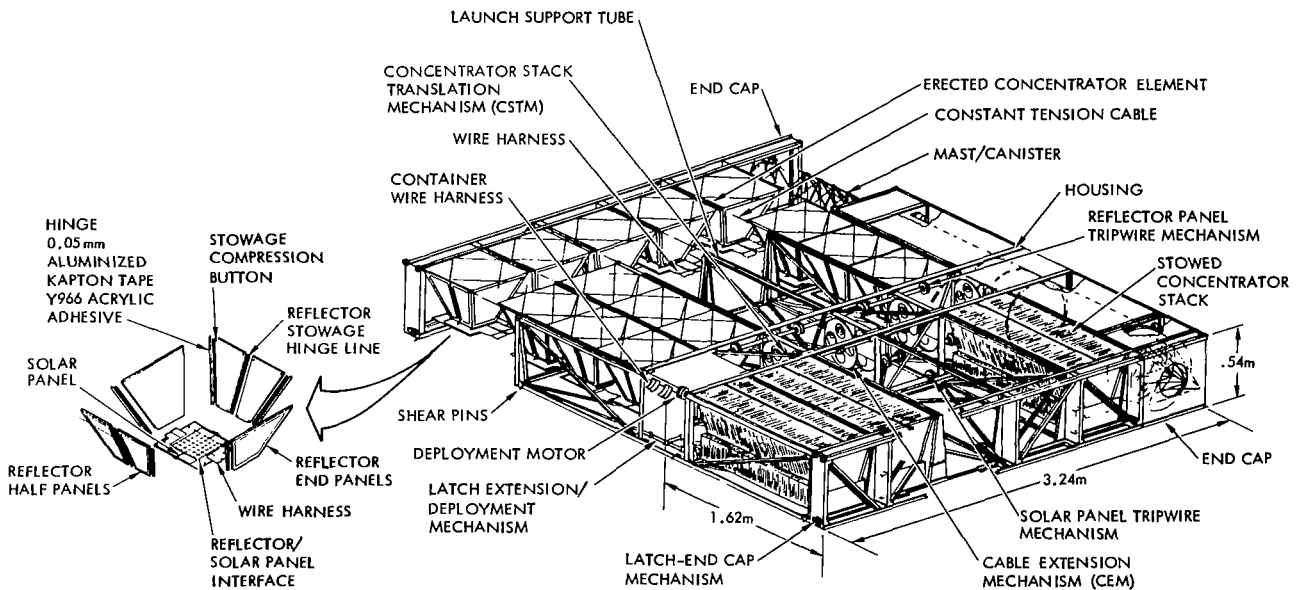
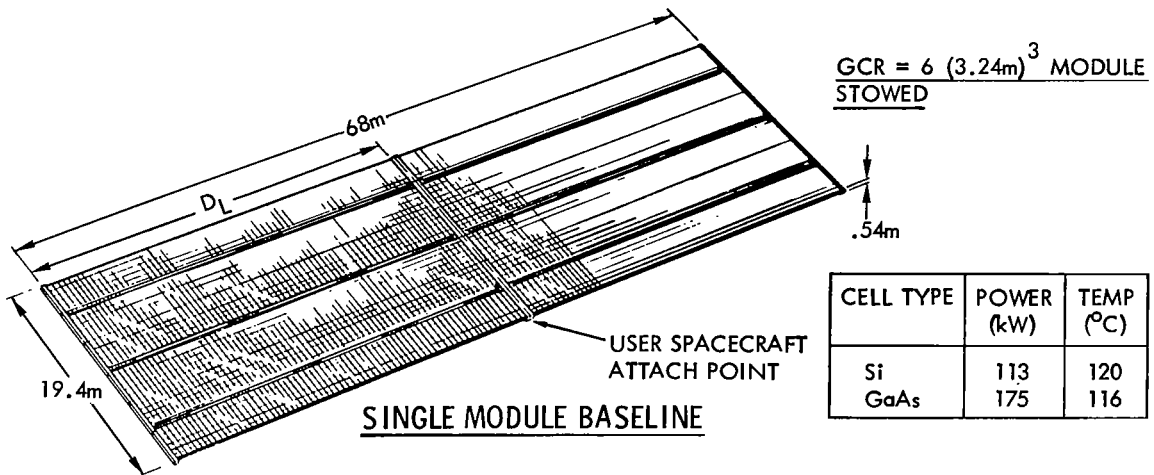

Figure 4

ARRAY MODULE PRELIMINARY DESIGN BASELINE PARAMETERS

This figure provides a summary of the physical and performance characteristics of the baseline array configuration. Each deployable mast (0.44 meter in diameter) is stowed in a canister that is within an envelope of 0.54 meter in diameter and 1.62 meter in length. The extended length of each mast from the canister (D_L) is 32.4 meters which allows extending 66 concentrator elements in each row (per side). A total of 4,356 concentrator elements, each having an aperture area of 0.5 by 0.5 meters, are utilized in the module. The stacking parameter, N, indicates that six containers are used in the module (three with pairs of masts and three without masts). The operating temperature in space for the Si solar cells is 120°C and 116°C for the GaAs solar cells. The beginning of life power output of the array module in low Earth orbit is 113 kW for the Si version and 175 kW for the GaAs version. The total mass for the array module is 4264 kg (Si) and 4242 kg (GaAs), respectively.



CELL TYPE	POWER (kW)	TEMP (°C)
Si	113	120
GaAs	175	116

AREA:

NUMBER OF CONTAINERS	NUMBER OF MASTS	NUMBER OF CONC STACKS	NUMBER OF CONC PER STACK	MODULE WIDTH (m)	MAST DIAMETER (m)	D_L (m)	DEPLOYED ARRAY AREA (m ²)	NUMBER OF CONC	TOTAL CONC APERTURE (m ²)	OVERALL PACKING FACTOR (%)
6	6	66	66	19.4	.44	32.4	1320	4356	1089	82.5

WEIGHT:

N	NUMBER OF MASTS	NUMBER OF CONC	CONCENTRATOR ELEMENT (kg)				CONTAINER AND CANISTERS (kg)		TOTAL (kg)
			REFLECTORS (FILM FRAME)	SOLAR PANEL	HARNESS	TOTAL	CONTAINERS/MECHANISMS & HARNESS	CANISTER/MAST	
6	6	4356	.253	.305	.11 (Si) .09 (GaAs)	.67 (Si) .65 (GaAs)	712 (Si) 799 (GaAs)	630	4264 (Si) 4242 (GaAs)

Figure 5

ARRAY MODULE (BASELINE) PRIMARY STRUCTURAL ANALYSIS

The design criteria to size the array system was taken to accommodate a range of applications. Small spacecraft systems (50,000 kg) which require less power and smaller arrays to 200,000 kg space station class systems (with Shuttle attached) with lower stationkeeping disturbances were considered. Design loads were dominated by stationkeeping thrust loads on the deployed array. The sizing of the design addressed structural integrity, that is, strength and structural stability. User spacecraft system controls considerations defined the mast stiffness to develop compatible modal characteristics. A hybrid mast (combination single-laced and double-laced) configuration was selected for the baseline array module design. A 1.5 ultimate load factor was used which indicated that the deployed array module would perform satisfactorily up to acceleration levels of 0.008 g.

- DESIGN LOADS**

 - STATION KEEPING
 - TENSION
 - THERMAL
 - SOLAR WINDS
 - GRAVITY GRADIENT

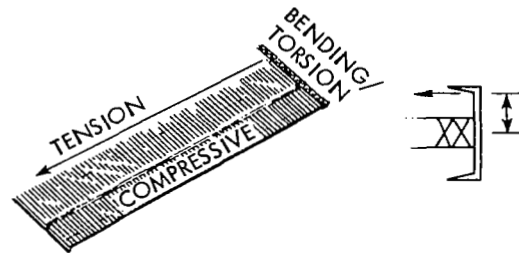

DYNAMIC RESPONSE

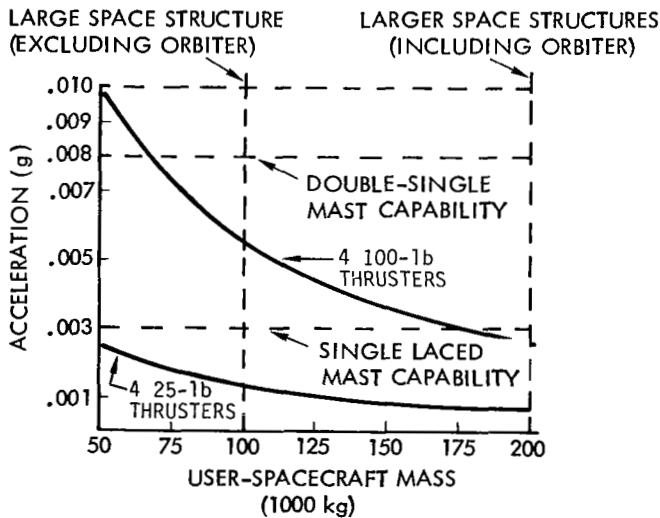

- ANALYSIS**

 - STABILITY
 - MAST / TENSION
 - GENERAL STABILITY
 - LOCAL STABILITY
 - MODAL
 - BANDWIDTH
 - COUPLING CHARACTERISTICS
 - TRANSIENT
 - INTERNAL LOADS

Figure 6

ARRAY MODULE (BASELINE) DYNAMICS ANALYSIS

Appendage-clamped frequencies were developed to assess user spacecraft controls compatibility. A decade separation of controls bandwidth with appendage frequencies generally assures no interaction. Systems being designed with less separation, including intersection of structural frequencies with controls frequency range, would require precise knowledge of the structural frequency and the associated damping. An indication of loads and pointing sensitivity to transient loading to the user spacecraft is shown for two typical configurations. Case 1 represents the baseline array module configuration and Case 2 configuration assumes an array module deploying concentrator elements from the container housing in one direction only. The response frequencies, end cap (tip) accelerations and the mast root moment (M) are provided for both cases (R is the rigid body mode in the disturbance direction).

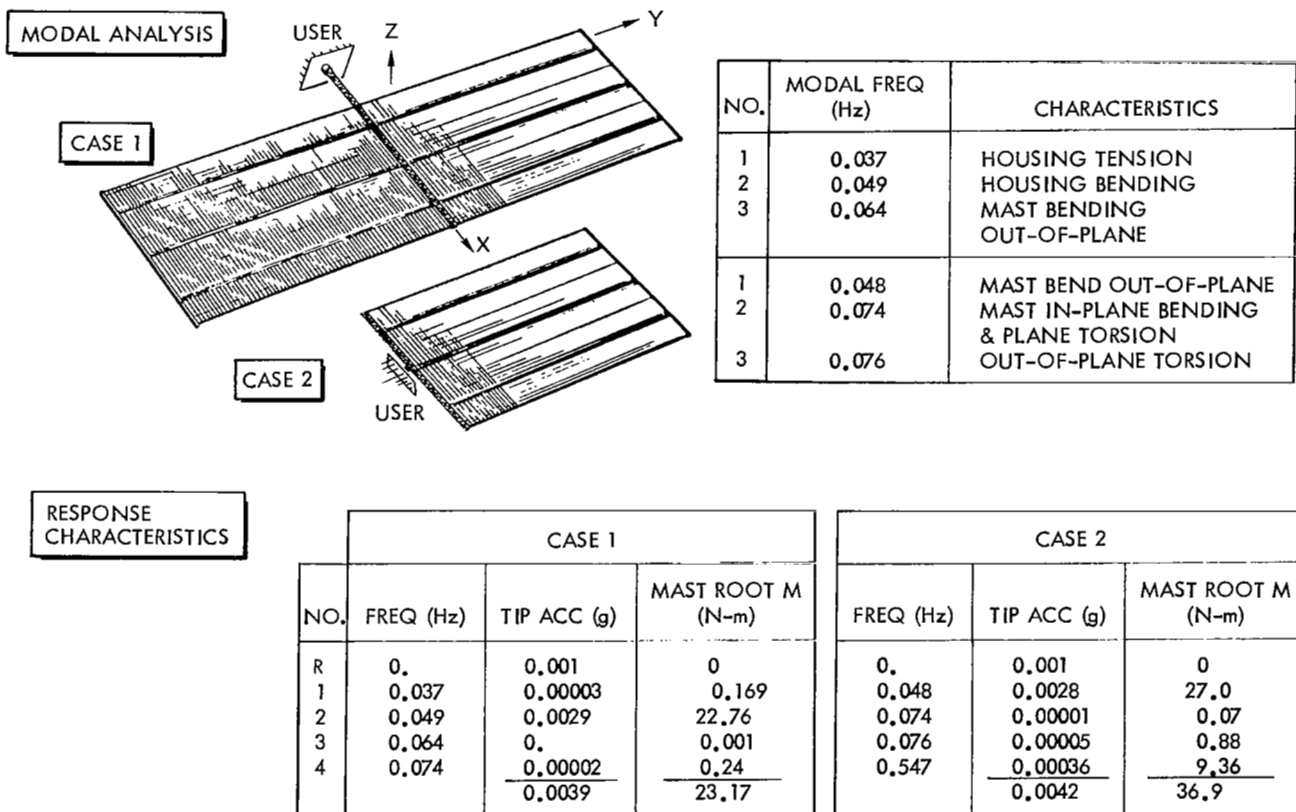

Figure 7

ARRAY MODULE (BASELINE) DIMENSIONAL STABILITY AND DEFLECTIONS

Power performance of the array is influenced by the pointing of the concentrator assembly. Analysis of stationkeeping disturbance influence on pointing is provided in the figure. The settling time sensitivity on output power was analyzed. This analysis is highly dependent on damping assumed. For a stationkeeping acceleration of 0.008 g and a 1.5 percent damping, the array module pointing error would be within 3 degrees in less than one minute. The dimensional stability and deflection values have been estimated to result in an average pointing of 1.4 degrees. A value of 3 degrees has been utilized in estimating the array power performance values.

- .008g STATIONKEEPING ACCELERATION (HYBRID MAST)
- 1.5% DAMPING

20N SUPPORT CABLE (WITHIN PRESENT TECHNOLOGY)
 7N CONCENTRATOR TENSIONER
 98% POWER OUTPUT .9 min
 99+% POWER OUTPUT 4.2 min

STRUCTURAL ELEMENT	NORMAL OPERATIONS (OUT-OF-PLANE CURVATURE) (DEGREE)	.01g STATIONKEEPING MANUEVER (OUT-OF-PLANE TRANSLATION) (m)
MAST	0.001 (THERMAL)	3.0
CONTAINER/HOUSING	0.57 (THERMAL)	0.3
CONTAINER/END-CAP	0.57 (THERMAL)	NEGLECTIBLE
CONCENTRATOR SUPPORT CABLE	0.01 (ATM. DRAG)	0.7
SUB TOTAL	0.81	-
MANUFACTURING TOLERANCES	± 0.25	-
ARRAY POINTING	± 0.5	-
TOTAL SUN POINTING ERROR	1.4	-
REMARKS	3.0 DEGREES USED IN PERFORMANCE ESTIMATES	STATIONKEEPING TRANSLATIONS (DISPLACEMENTS) ARE STRUCTURALLY ACCEPTABLE

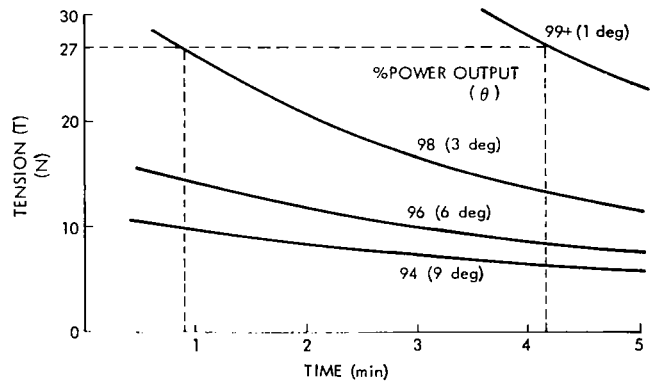
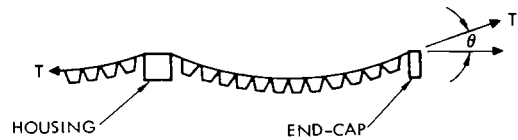

FLIGHT TEST REQUIRED TO VALIDATE ANALYSIS

Figure 8

ARRAY MODULE (BASELINE) AND SPACECRAFT INTERFACE

The user spacecraft interface must provide certain characteristics. The structural requirements originating from stationkeeping are 6300 Nm moment, 3100 Nm torsion, and 600 N axial for the attach and backup structure. The spacecraft must provide pointing accuracy of ± 0.5 degrees at the interface. Peak value power requirements to deploy and retract each side of the array module are 780 watts at 28 Vdc (about 27 minutes duration). The interface must accommodate power transfer of 20-175 kW from the array module depending upon the type of solar cells used (Si or GaAs) and the number of containers (up to six) that comprise the module.

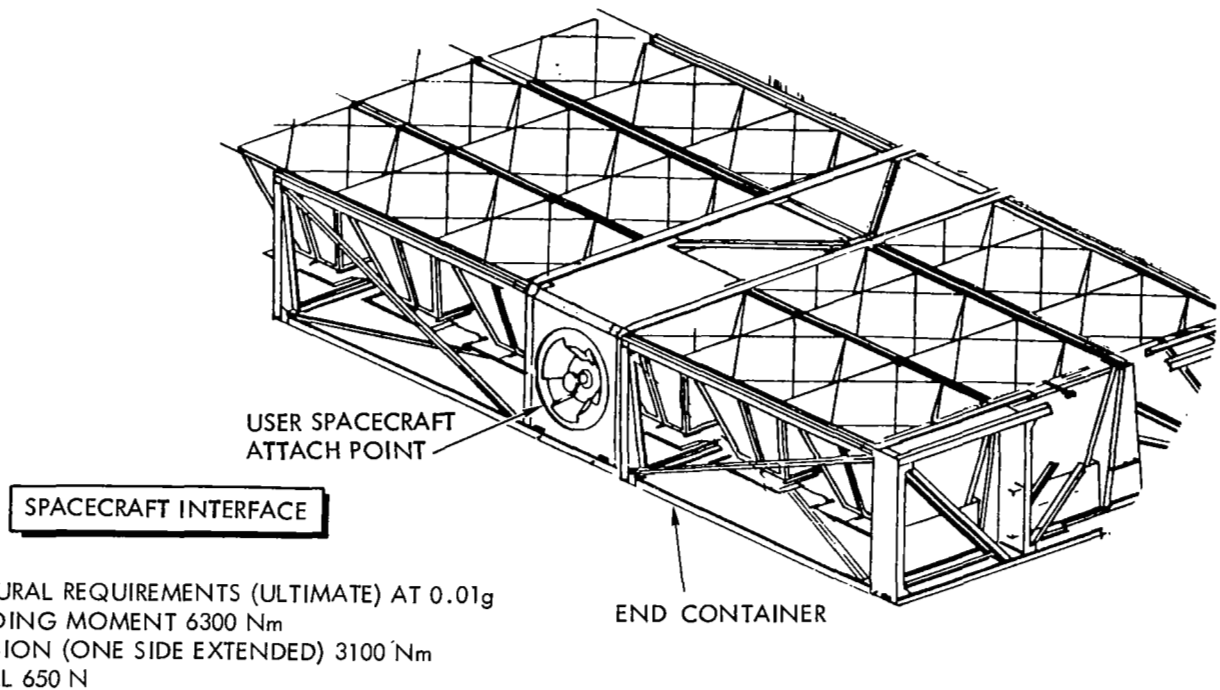

Figure 9

ARRAY MODULE INTERFACE EXAMPLE (SPACE STATION APPLICATION)

The baseline array module configuration adapts well to modifications for potential specific space vehicle applications. This figure illustrates an array module which extends from the housing in one direction only. The baseline module container housing design is modified to be essentially one-half of the double direction extending baseline configuration. The mounting attachment would be made at the back of the housing instead of at one end. The width of the array can be increased by attaching similar containers end-to-end. Thus the number of masts used and the aspect ratio of the array can be tailored to the specific application requirements.

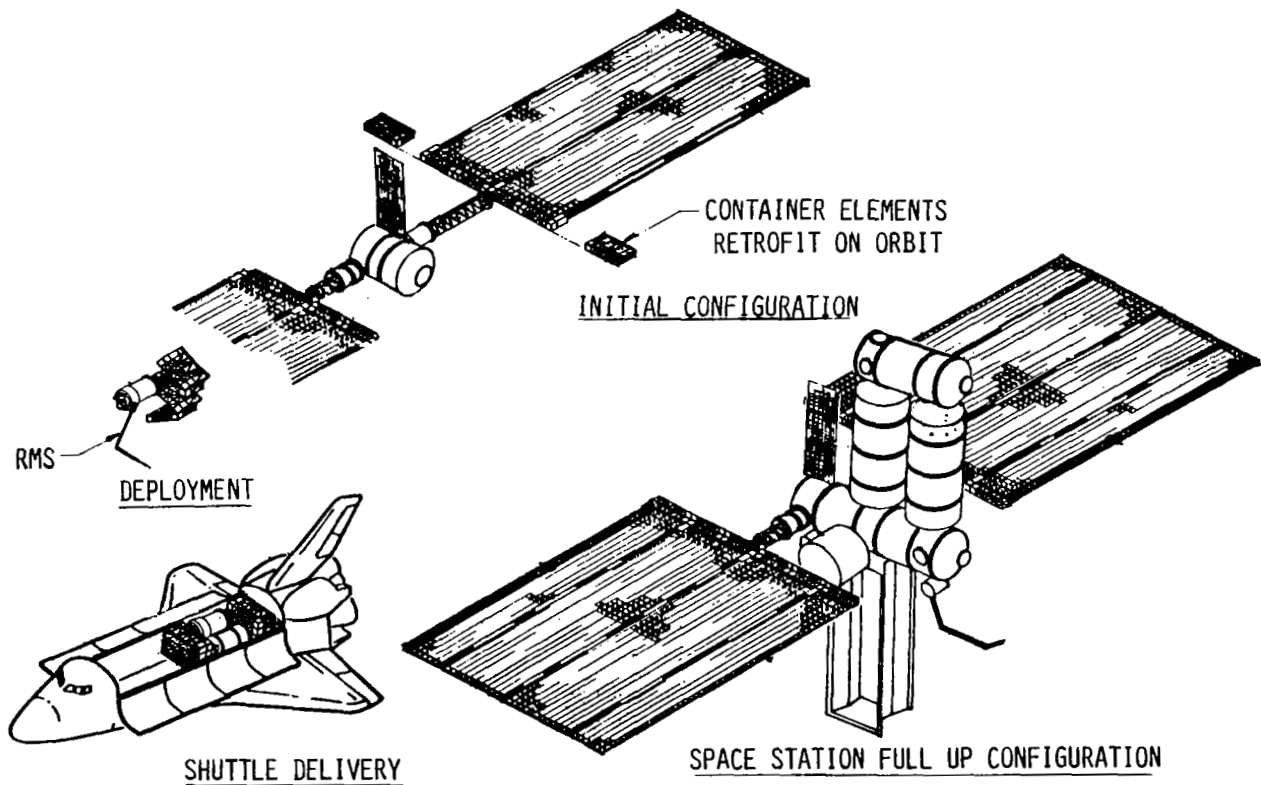
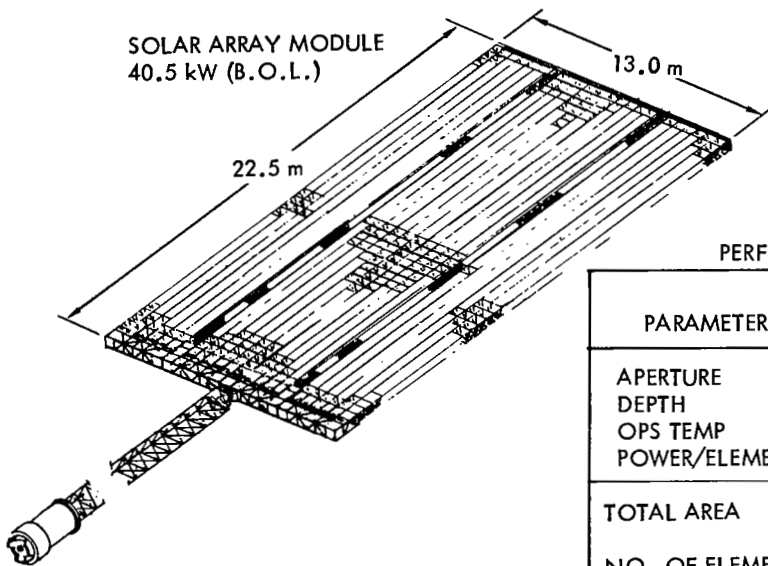

Figure 10

MODIFICATION FOR SPACE STATION APPLICATION (EXAMPLE)

This figure illustrates a single direction extension concentrator array module sized to provide 40.5 kW at the beginning of life (BOL). Two such modules can be used for a low Earth orbit space station to provide about 75 kW power at the end of ten years. A smaller concentrator element (one-fourth aperture area of the baseline element) is used to reduce the solar cell operating temperatures from 116°C to 90°C (GaAs versions) without a significant increase in cost per watt of power. The number of concentrator elements per module (3,696) would be less than the 4,356 larger concentrator elements utilized in the baseline configuration. The power-to-weight ratio is about 65 percent of a lightweight planar array utilizing Si solar cells. However, the power-to-deployed area would be about 40 percent greater than the planar Si array. Transportation costs to orbit are volume limiting rather than weight limiting, thus the more compact concentrator module storage design would not suffer a transportation cost penalty. The smaller deployed array for the GaAs concentrator array would result in less drag penalty in low Earth orbit, thereby reducing mission operational costs.



- SMALLER ELEMENT SIZE ~ 1/4
- REMAINS DEPLOYABLE & RETRACTABLE
- SINGLE DIRECTION EXTENSION
- SIMPLER FOLD & SAME COMPACT STOWAGE

PERFORMANCE OF GaAs SOLAR ARRAY

PARAMETERS	MULTI 100 kW (B.O.L.) 175 kW MODULE	75 kW (10 yrs) (TWO MODULES)
APERTURE	.5 m X .5 m	.25 m X .25 m
DEPTH	.37 m	.185 m
OPS TEMP	116°C	90°C
POWER/ELEMENT	40.5 W	11 W
TOTAL AREA	1320 m ²	585 m ²
NO. OF ELEMENTS	4356 (.5 m X .5 m APERTURE)	7392 (.25 m X .25 m APERTURE)
W/kg	41	40
W/m ²	133	135
\$/W	166	168

• DD&T REQUIREMENTS
SIMILAR TO PLANAR

Figure 11

DEMONSTRATION EXPERIMENT CONFIGURATION

This figure illustrates the simplicity of design for the low concentrator array configuration. The design is modular and consists of high numbers of relatively few different types of components thereby enhancing mass production techniques. The principles used in design and the existing state-of-art for subcomponents suggest that a flight demonstration article with minimum ground verification tests would be the most cost-effective means to demonstrate flight readiness for near-term mission applications. As an example, a recommended test article could consist of a container using a pair of masts to extend elements in opposite directions as shown in the figure for flight evaluation of structural and dynamic control performance. Eight rows of concentrator elements can be used, two on both sides of each mast for simplicity. Both GaAs and Si solar cells can be used in a few of the concentrator elements for performance monitoring. The remaining concentrator elements would use proper mass simulation in place of active cells. Total module weight is estimated at 700 kg and it would have a deployed area of about 180 m². Although a single direction extension module may be used to simulate a space station application array module, the dual direction extension concept would allow better dynamics control interaction evaluation. About 260 watts of power would be required to extend or retract each side. For example, one side can be deployed with the other side retracted to provide greater insight into structural and dynamic interactions.

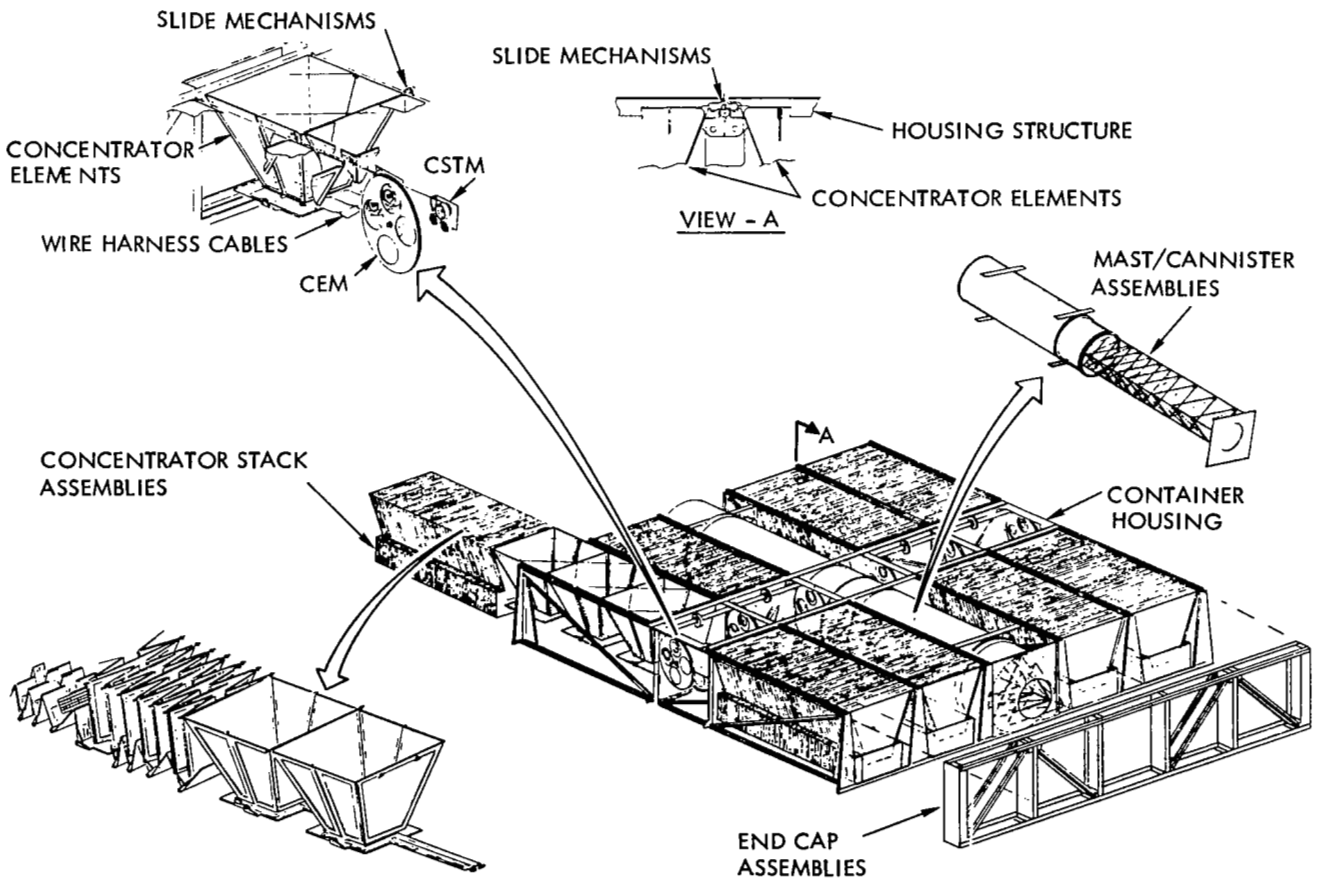

Figure 12

REFERENCES

1. French, E. P.; and Menager, J. A.: Study of Multi-100 kW Solar Arrays for Earth Orbit Applications. NASA CR-170792, May 1980 (SSD 80-0064, Rockwell International Corporation).
2. Nalbandian, S. J.: Low Concentration Ratio Solar Array for Low Earth Orbit Multi-100 kW Application. SSD 83-0075, Rockwell International Corporation, July 1983.

DEVELOPMENT OF TEST ARTICLE BUILDING BLOCK (TABB)
FOR DEPLOYABLE PLATFORM SYSTEMS

H. S. Greenberg and R. T. Barbour
Shuttle Integration and
Satellite Systems Division
Rockwell International
Downey, California

BUILDING BLOCK FOR DEPLOYABLE PLATFORM SYSTEMS

This paper describes the concept of a Test Article Building Block (TABB) that Rockwell has developed for NASA MSFC. The TABB is a ground test article that is representative of a future building block that can be used to construct LEO and GEO deployable space platforms for communications and scientific payloads. As shown in Figure 1, this building block contains a main housing within which the entire structure, utilities, and deployment/retraction mechanism are stowed during launch (Figure 2). The end adapter secures the foregoing components to the housing during launch. The main housing and adapter will provide the necessary building-block-to-building-block attachments for automatically deployable platforms such as those shown in Figure 1. Removal from the Shuttle cargo bay can be accomplished with the remote manipulator system (RMS) and/or the handling and positioning aid (HAPA). In this concept, all the electrical connections are in place prior to launch with automatic latches for payload attachment provided on either the end adapters or housings. The housings also can contain orbiter docking ports for payload installation and maintenance.

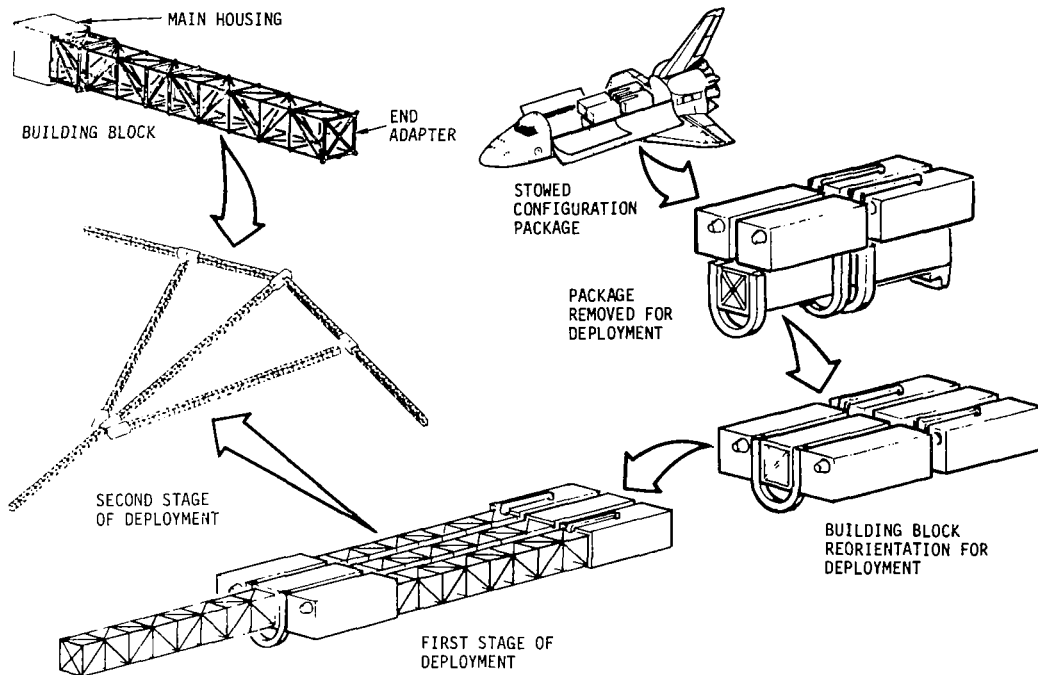

Figure 1

TABB DESCRIPTION

Figure 2 pictorially describes the TABB major components. This test article is designed for a room temperature/ground test verification of deployment and retraction capability, stiffness, strength, and modal frequency characteristics. For minimum development cost the square truss structure is currently constructed of aluminum (6061-T6) tubes, and the mechanism and drive motors, gear box, tachometers, and encoders are not designed to the more stringent Shuttle and space environment requirements. Later in the program, however, it is planned to retrofit a low CTE (coefficient of thermal expansion) composite truss design.

The major components of this test article are: the main housing; three mechanization systems consisting of a batten deployment/retraction jackscrew system (that translates the battens one at a time) and a diagonal and a longeron latch unlocking system; a positioning system to control the deployment and retraction; a jackscrew support frame assembly that supports the ends of the batten deployment/retraction jackscrews; the square truss containing folded trays for utilities lines; a precompression system to eliminate structure joint backlash; and an end adapter at the end of the truss. The housing and payload carrier frames shown contain inserts for attachment of the NASA MSFC payload carriers.

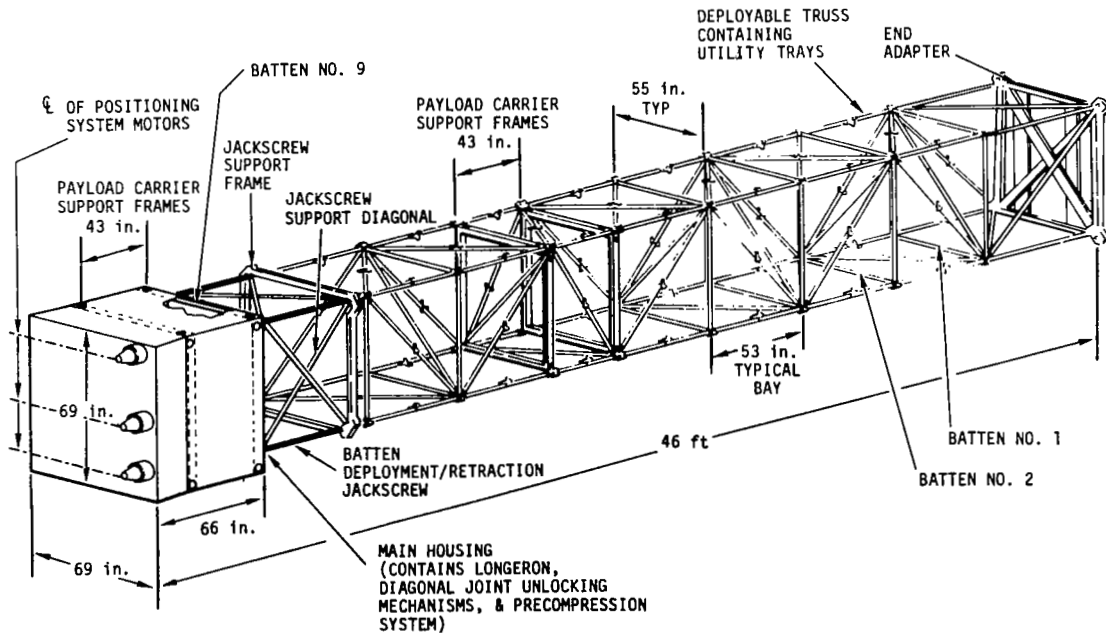

Figure 2

DEPLOYABLE TRUSS CONCEPT

Figure 3 describes the TABB deployable truss major design features. The deployable truss contains square batten (stabilized by a tension/compression diagonal) which contain half nuts at each of the four corners. Through engagement of each of the four half nuts with each of the four batten deployment/retraction jackscrews, counterclockwise rotation of the jackscrew imparts outward (deployment) linear motion to the batten, while the opposite imparts inward (retraction) motion to the batten. Deployment or retraction is respectively accomplished by detents holding the aft batten while deploying or retracting the forward batten. During deployment, each of the four diagonals is unfolded and each of the four telescoping diagonals is extended. Both designs have spring-activated pins in latches at the center joints that, upon locking, provide axial and moment structural continuity. Both designs have end rod fittings with spherical bearings and turnbuckles for precise member length adjustment. The aforementioned center joint spring-activated pins must be unlocked to permit retraction. This is accomplished with each of the diagonal and longeron unlocking systems that contain tripping devices that rotate cammed surfaces on the latch mechanisms to depress the locking pins. The unlocking of these joints permits retraction of the bay.

The truss design also contains trays onto which electrical power, data lines, and, if necessary, fluid lines can be mounted. The trays are hinged from the batten members and fold as shown in the lower right of the figure. During launch, the trays provide lateral support to the folded longerons.

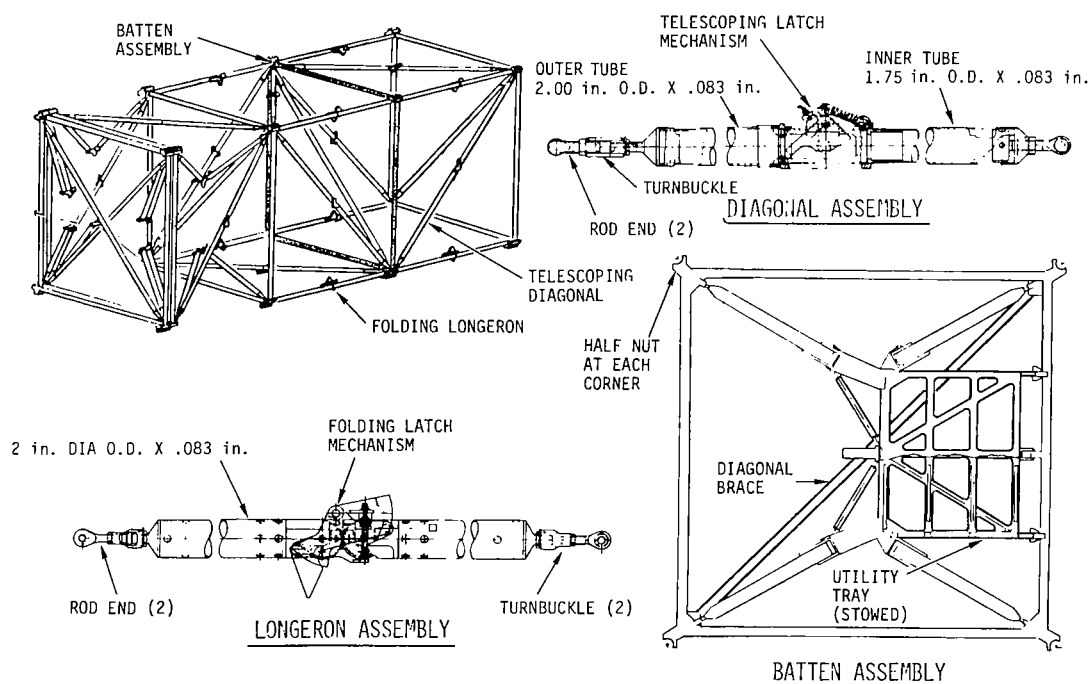

Figure 3

DEPLOYMENT/RETRACTION MECHANISM

Figure 4 illustrates (in the deployed configuration) the major features and orientation of the TABB mechanization system. For clarity, the ten-bay truss structure is not shown. This system provides fully controlled bay-by-bay deployment/retraction capability with maintenance of root strength through all phases of deployment. The mechanism includes the batten deployment/retraction jackscrew system, the longeron unlocking system, and the diagonal unlocking system. The batten deployment/retraction system (Figure 5) consists of four guide rail, splined shaft, and jackscrew assemblies mounted in a slide carriage located at each of the four corners of the main housing. In the first stage of deployment, clockwise rotation of each of the spline shafts advances the slide carriage and jackscrew out of the housing into the configuration shown. Concurrently, the jackscrew support frame assembly is advanced to the configuration shown with automatic locking of the telescoping diagonals. A controller-driven single motor slaved to a chain and sprocket system drives all four systems. The longeron unlocking system (Figure 5) consists of four guide rail, jackscrew, carriage, and tripping device assemblies. These systems are located as shown, i.e., adjacent to the individual batten deployment/retraction assemblies. The diagonal unlocking assemblies are the same as that of the longeron unlocking system except for the tripping devices, and are located at the center of the housing sidewalls. The longeron and diagonal unlocking systems are each controller driven by a single motor slaved to a chain and sprocket system to drive all four assemblies.

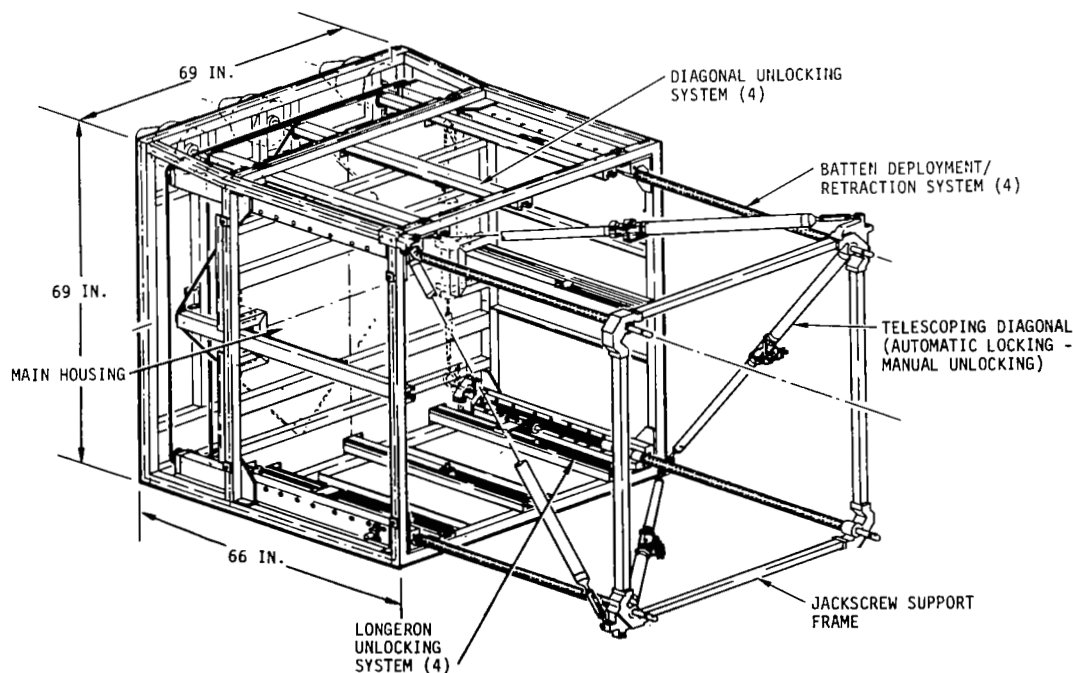

Figure 4

DEPLOYMENT/RETRACTION MECHANISM (CONTINUED)

Figure 5 further describes the deployment/retraction mechanism. The batten deployment/retraction jackscrew system shown illustrates one of the four jackscrew assemblies. The jackscrew, carriage, and spline assemblies are cradled within a rigid rail. A splined bushing at the aft end of the two-inch-diameter jackscrew encircles a splined shaft that extends nearly the entire length of the jackscrew. The jackscrew splines extend beyond the aft end of the rails where a chain and sprocket are attached.

Encircling the rotating jackscrew is a carriage fitting that has external ears that engage matching grooves running the length of the rails. The carriage is pulled forward with the jackscrew, during deployment of the first bay, until a hole in the side of the carriage engages a spring-operated pin mounted near the forward end of each rail, thereby locking the carriage. During retraction of the final bay, the pin is manually retracted from the carriage, thus allowing the jackscrew to be retracted into the housing.

One of the longeron and one of the diagonal unlocking assemblies are each shown below in the partially deployed configuration. In the stowed configuration, the carriages are entirely within the main housing. The separate longeron and diagonal unlocking systems are operated only during retraction and are respectively used to unlock the longeron and diagonal center joint latches just prior to the start of the batten retraction. The diagonal and longeron center joint latches are respectively unlocked by forward motion of the trip lever pin and tripping probes mounted on the deployable/retractable carriages installed within rails and driven by the one-inch-diameter jackscrew.

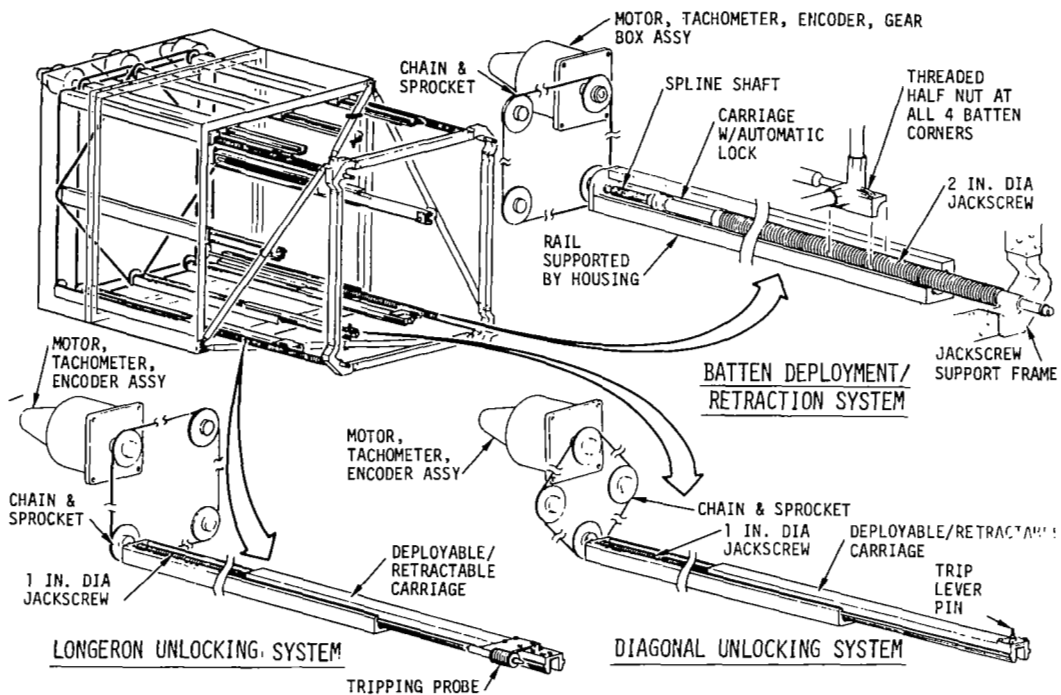

Figure 5

POSITIONING SYSTEM REQUIREMENTS

Figure 6 describes the motion profile associated with the total deployment and retraction of TABB. The motion profiles are separately delineated for the batten deployment/retraction system and the unlocking systems. The motion profile will be preprogrammed into a controller computer that will drive the servo motors that, in turn, drive the jackscrews. Each of the three servo motors has a tachometer and encoder to instantaneously monitor rpm and revolutions. Revolutions are counted to ± 0.001 revolution by the encoder which corresponds to a jackscrew linear dimension of 0.00025 in. for the batten deployment/retraction system.

Referring to the motion profile during deployment, the first profile shown corresponds to deployment of the mechanism to the configuration shown in Figure 4, with automatic locking of the carriages. Concurrently, Bay 1 is deployed because the end adapter (Figure 2) is pushed outward by the jackscrew support frame. Bays 2 through 10 are individually deployed as shown by reversal of the jackscrews, i.e., counterclockwise rotation. All the bays are deployed by rotating 196 revolutions, except for Bay 6 which is shorter and requires only 156 jackscrew revolutions.

In the retracting phase, the eight unlocking carriages are initially positioned such that each of the tripping probes is one in. away from the latch trip levers. The four diagonal and four longeron latches in Bay 10 are tripped after 10 clockwise revolutions of the unlocking system jackscrews. After TBD milliseconds, the batten deployment/retraction system motors are rotated clockwise until Batten 9 (Figure 2) is placed on the rail. This procedure is continued as shown. The deviation shown for Bay 7 is due to the shorter length of Bay 6. The motion profile retraction of Bay 1 is described in Figure 7.

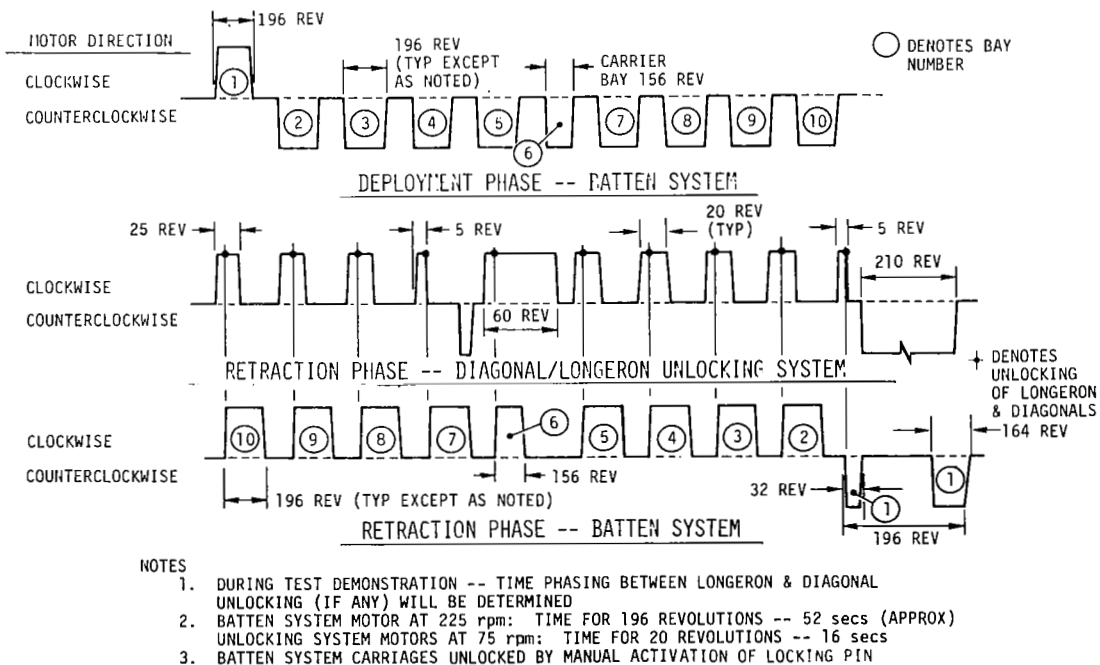

Figure 6

TABB DEPLOYMENT/RETRACTION DESCRIPTION

Figure 7 illustrates the key discrete stages of deployment and retraction previously described by the motion profile in Figure 6. Starting from the stowed package (View ①), the end adapter, which is the forward batten of Bay 1, is forward of the jackscrew support frame. The first stage of deployment positions and locks the jackscrews and the jackscrew support frame assembly, and develops (View ②) the first bay (Bay 1). At this point, the Batten 1 (Figure 2) half nuts are engaged with the aft end of the jackscrew thread. The batten deployment/retraction system jackscrews are reversed to start the deployment of Bay 2 (View ③).

Batten 2 (Figure 2) is held in place by spring-loaded detents (0 to 100 lb each) until Bay 2 is fully extended and locked, and is later overwhelmed by the jackscrew starting the deployment of Bay 3. In this manner, each of the bays (2 through 10) is deployed one at a time until the fully deployed configuration is achieved (View ④). The initial retraction of Bay 10 (View ⑤) is described in Figure 6, and continued according to the motion profile shown. As each bay is retracted, the battens are placed on the rail reengaging the spring-loaded detents. Also, as each bay is retracted, the carriages on the unlocking systems are advanced to the next unlocking position. This proceeds from Bay 10 through the unlocking of Bay 1 (View ⑥). Upon the unlocking of Bay 1, the batten deployment/retraction jackscrews are rotated counterclockwise 32 revolutions. The extended diagonal and longeron unlocking systems are then retracted (210 revolutions) to permit the final retraction of Bay 1.

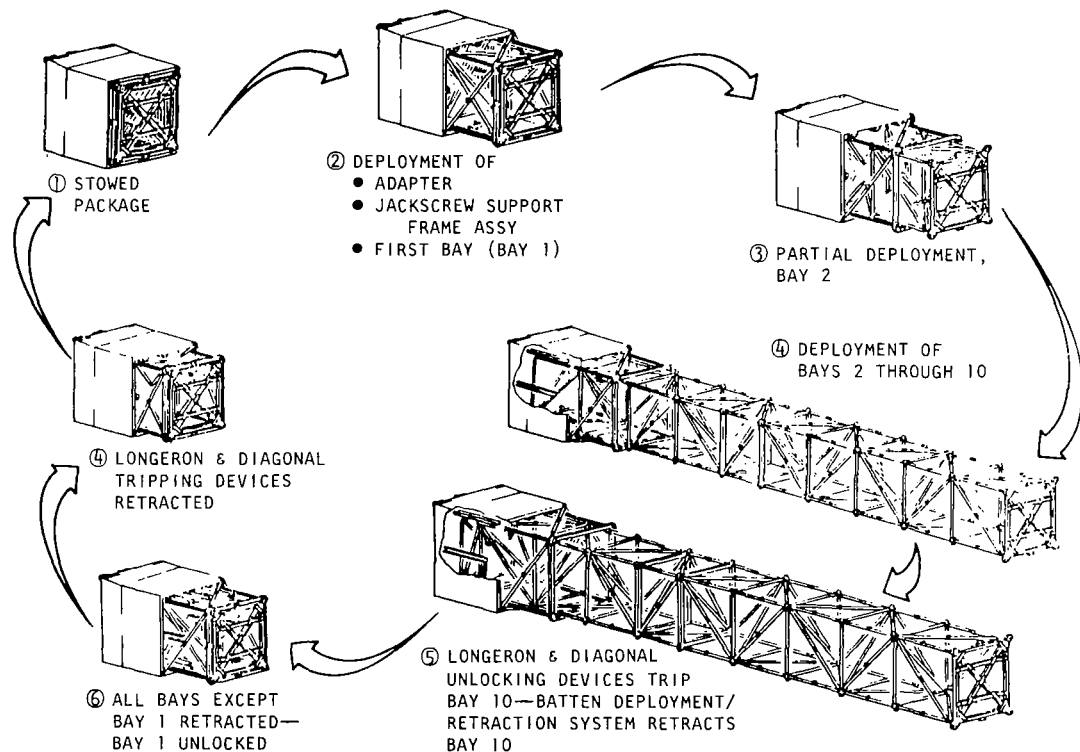

Figure 7

PRECOMPRESSION SYSTEM TO ELIMINATE JOINT SLOP

Figure 8 describes the major features of the precompression system provided to eliminate joint backlash in both the longerons and diagonals. A cable/bungee system is provided to apply up to 400 pounds of compression in each of the four truss longerons. This compression load will, through compatible strain, provide up to 75 pounds of precompression in the diagonals.

The precompression system consists of two spring bungee assemblies mounted on the aft end of the main housing. From either end of each bungee extend threaded rods that mate with a turnbuckle. From the opposite end of each turnbuckle is another threaded rod swagged to a long cable. The two cables from each bungee traverse laterally until they engage a pulley near the axes of the longerons. The cables wrap around the pulleys 90° and extend forward where they enter the longerons located at the four corners of the truss. The cables continue forward through the longerons of all ten bays. The cables exit the longerons of Bay 1 and engage another pair of fairleads mounted on the aft face of the adapter. These fairleads are canted in such a way that after the cables wrap 90° around the pulleys, they continue toward the geometric center of the adapter within its diagonal braces. Near the center of the adapter, a swagged ball on the cables attaches to adjustable fittings on the adapter.

The bungees are supported at the rear of the housing by two pairs of brackets that partially encircle the cylindrical body and still allow the body to move along its axis as the turnbuckles are utilized to preload the cables to their final 400-pound load.

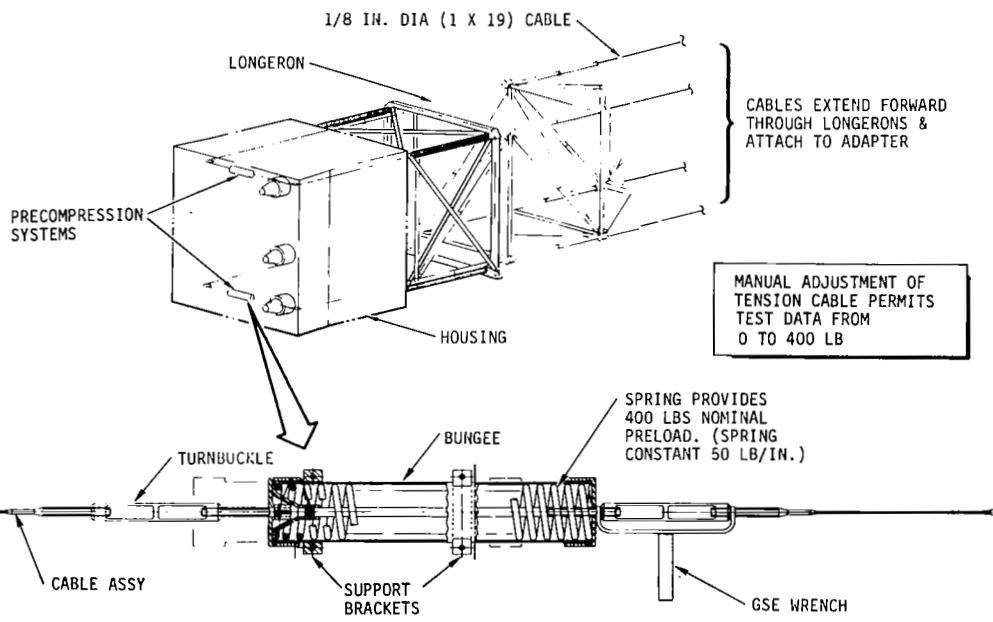

Figure 8

PROTOTYPE BUILDING BLOCK SIGNIFICANT DESIGN CHARACTERISTICS

Figure 9 delineates the most significant design characteristics of the prototype building block from which deployable platforms for low Earth orbit (LEO) or geosynchronous Earth orbit (GEO) can be constructed. As stated previously, the TABB is a ground test development article representative of the prototype design.

The building block automatic deployment and retraction are accomplished one bay at a time by a computer-driven positioning system. Since joint locking or unlocking is localized near the housing, it can be monitored by TV cameras and, if necessary, EVA remedial techniques. Also, the bay-by-bay deployment results in root strength at all times which permits orbiter docking and/or vernier reaction control system (VRCS) firing, if necessary. The deployment is within the housing cross-section envelope, thereby precluding any interference with adjacent members that would comprise a total platform. The structural behavior is expected to be predictable since joint backlash in the truss structure is eliminated by a precompression system. Since retraction may not be required in a total platform system, the unlock systems, drive motors, and associated equipment can be removed without impacting the remaining deployment mechanisms.

The building block design, as visualized in a platform system that is comprised of many building blocks, permits all electrical connections to be in place at launch. Further, all inter-building-block connections can be made automatically without a fixture, i.e., through the use of appropriate automatic latches. Finally, the housing permits ground installation of docking ports to accommodate orbiter docking for payload attachment and maintenance.

- AUTOMATIC BAY-BY-BAY DEPLOYMENT AND/OR RETRACTION TO FACILITATE IDENTIFICATION OF PROBLEM (IN THE EVENT THIS OCCURS)
- MAINTENANCE OF ROOT STRENGTH DURING DEPLOYMENT/RETRACTION - PERMITS ORBITER BERTHING & ORBITER VRCS FIRING, IF NECESSARY
- LONGITUDINAL DEPLOYMENT/RETRACTION WITHIN CROSS-SECTION ENVELOPE
- COMPONENTS FOR RETRACTION EASILY REMOVABLE IF APPROPRIATE
- PRECOMPRESSION SYSTEM NEGATES BACKLASH OF TRUSS STRUCTURE JOINTS
- ALL INTER-BUILDING-BLOCK ELECTRICAL CONNECTIONS IN PLACE PRIOR TO ORBITER INSTALLATION
- IN-SPACE INTER-BUILDING-BLOCK STRUCTURAL CONNECTIONS MADE AUTOMATICALLY WITHOUT FIXTURE
- HOUSING PERMITS GROUND INSTALLATION OF DOCKING PORTS
- PAYLOADS & PROPULSION MODULES ATTACHED USING RMS OR HAPA, OR BOTH
- NO OTHER FIXTURES REQUIRED

Figure 9

PROPOSED SCHEDULE FOR FABRICATION AND DEVELOPMENT TESTING OF TABB

Figure 10 illustrates the schedule proposed to NASA MSFC for fabrication and development testing of the TABB, which is the next step in the development of deployable structures for large space platforms. This schedule is consistent with 1986 technology readiness.

The major features of the program are listed below at the left, and indicate the overall scope of the 2-year program. Since the TABB truss is constructed of aluminum tubes and metal fittings, a parallel development of low CTE composite longerons, diagonals, and batten corner joints is proposed. According to the proposed plan, retrofit of the low CTE design is planned by the end of FY 1985.

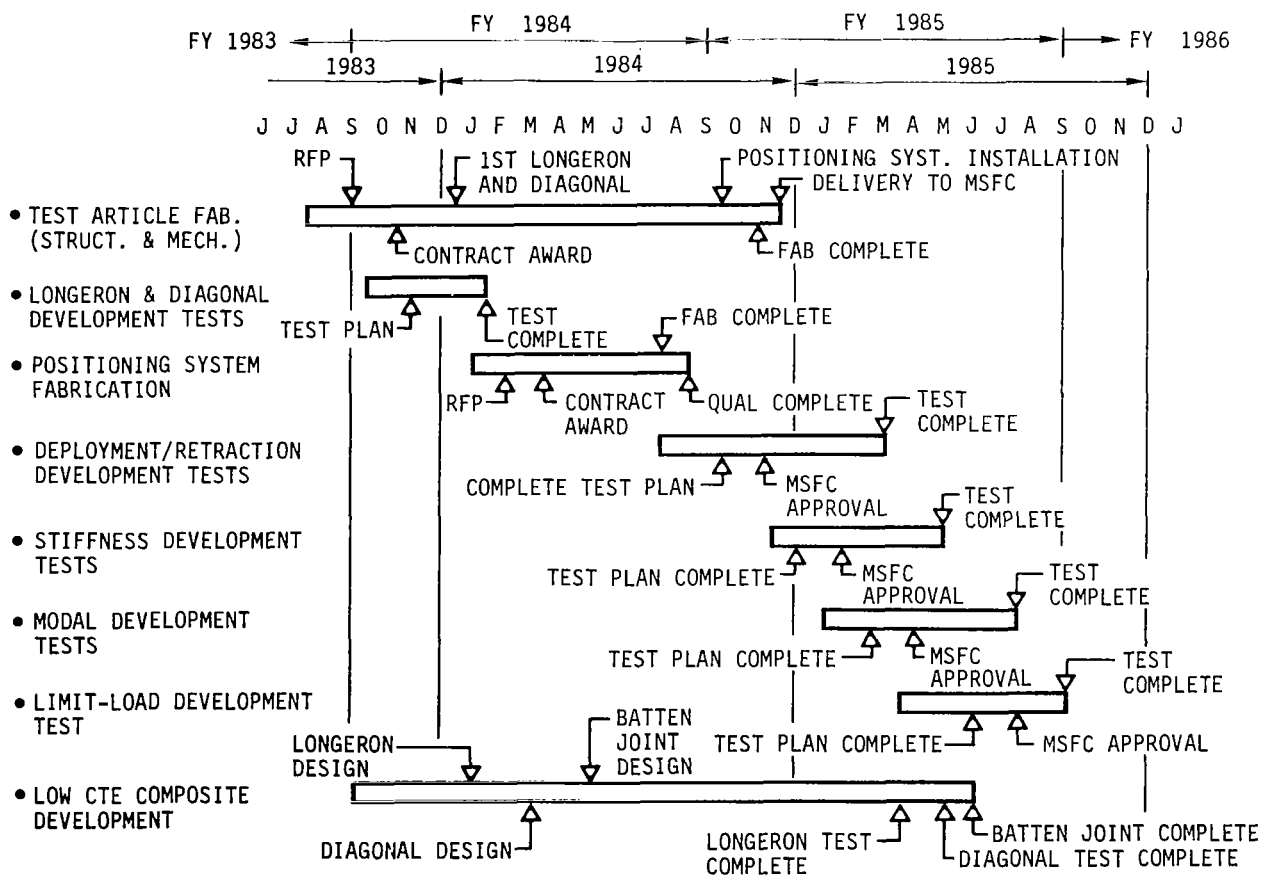

Figure 10

CURRENT DESIGN VERIFICATION NEEDS

Figure 11 illustrates the expected flight experiment needs of the prototype building block design of which the TABB is representative. These needs have been determined by review of the verification needs listed at the left and judgmental consideration of the capability of analyses and ground testing to resolve each of the verification needs. To accomplish the assessment, a scoring system was used to quantify the expected relative confidence level attainable with analyses and ground testing. A score of 8 was considered adequate to verify the building block design without need for a flight experiment. Hence, a value of less than 8 indicates the need for flight testing.

The figure indicates a flight experiment is required to verify the deployment and retraction of a building block using an aluminum truss. This is necessary because of the uncertainty of in-space thermal dimension changes in the truss bay length during deployment and, in particular, during retraction. Also, thermal stability, truss damping characteristics (with and without longeron precompression) with trays and utilities lines, and power requirements are needs requiring flight verification. It is pertinent to note that the confidence of verification needs that are judged not to require flight verification can be enhanced by a flight experiment that is required for the specified needed test verifications.

VERIFICATION NEEDS	CONFIDENCE LEVEL			COMMENTS	
	ANALYSIS		GROUND TEST		FLT TEST REQUIRED
SHUTTLE LAUNCH ENVIR. SUITABILITY • STEADY-STATE ACCELERATION • MECHANICAL VIBRATION • ACOUSTIC VIBRATION	8 4 4		10 8 8	} NO	INCREASED CONFIDENCE WITH FLIGHT TEST
DEPLOYMENT • ZERO-G • VACUUM, THERMAL, RADIATION • DYNAMIC LOADS	ALUM. 6 COMPOSITE 6 4 6		ALUM. 9 COMPOSITE 9 6 9	} YES	FOR ALUMINUM DESIGN
RETRACTION • ZERO-G • VACUUM, THERMAL, RADIATION • DYNAMIC LOADS	ALUM. 6 COMPOSITE 6 2 6 6		ALUM. 9 COMPOSITE 9 4 9 9	} YES	FOR ALUMINUM DESIGN
DEPLOYMENT/RETRACTION/REMEDIAL PROCEDURES • VISUAL INSPECTION • CORRECTION IN ZERO-G		0 0	8 8	} NO	INCREASED CONFIDENCE WITH FLIGHT TEST
COMPRESSION SYSTEM ACTIVATION • ZERO-G • VACUUM, THERMAL, RADIATION • INERTIA LOADING	ALUM. 8 COMPOSITE 8 6 8		ALUM. 9 COMPOSITE 9 8 9	} NO	
STATIC STIFFNESS ZERO-G VACUUM, THERMAL, RADIATION	9 8		10 9	NO	
MATERIALS SUITABILITY	6		8	NO	TEST DOES NOT ADD LONG-TERM CONFIDENCE
ULTIMATE STRENGTH	9		10	NO	
THERMAL STABILITY	4		6	YES	ALUM. OR COMPOSITE
DAMPING CHARACTERISTICS ZERO-G VACUUM, THERMAL, RADIATION	2 2		4 4	} YES	
POWER REQUIREMENTS ZERO-G VACUUM, THERMAL, RADIATION	6 4		9 6	} YES	
UTILITIES DEPLOYMENT/RETRACTION	4		8	NO	INCREASED CONFIDENCE WITH TEST
RANKING (0 TO 10): 0 = NONE 8 = HIGH 2 = LOW 10 = EXCELLENT 4 = FAIR 6 = GOOD					

Figure 11

A DEPLOYABLE STRUCTURE AND SOLAR ARRAY
CONTROLS EXPERIMENT FOR STEP

T. S. Nishimoto
Shuttle Integration and Satellite Systems Division
Rockwell International
Downey, California

CONTROLS ISSUES

Flight experiments like STEP are an important development phase. Currently, the area of controls is impacted by several on-orbit uncertainties. Plant models for controls verified or developed by ground testing, when dimensionally possible, suffer corruption by the environment. Gravity, air, and a realistic thermal environment lead to uncertainties. Controls design is attempting to accommodate this possible state of model uncertainties. The designs range from simple analog fixed gains to sophisticated adaptive systems. Both cost and computing requirements are elevated as more sophisticated approaches become necessary.

The STEP program provides a development test opportunity to define more clearly the controls design task.

- **UNCERTAINTY OF PLANT MODELS**
- **REALISTIC TESTING FOR VERIFICATION**
 - ZERO g, VACUUM, THERMAL
 - DATA BASE FOR 1 g TEST DEVELOPMENT
- **CONSEQUENCE TO CONTROLS DESIGN**
 - ACCOMMODATE MODEL UNCERTAINTY
 - INCREASED PENALTIES
 - POWER
 - SOFTWARE, COMPUTING
 - RISK

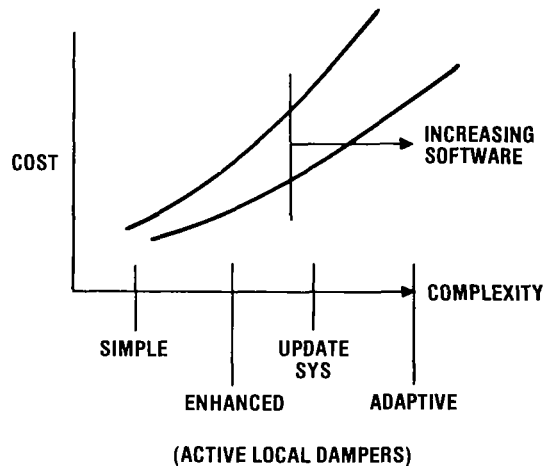

CONTROLS EXPERIMENT

This figure shows a candidate configuration for a controls experiment on STEP. The elements of the experiment are the mast, which is MSFC's deployable structure; the solar array, which is MSFC's low concentration ratio design; and an articulation module between the two. The characteristic dimensions are very compatible for integration on a pallet such as STEP's proposed configuration.

The controls objective would be the measurement of orbiter interaction as well as the system identification of the appendages. The flight experiment configuration would also provide a test bed for various active vibration controls concepts.

- **CANDIDATE GEOMETRY**

- MSFC DEPLOYABLE STRUCTURE
- MSFC LOW CONCENTRATION RATIO SOLAR ARRAY (LCRSA)

- **PURPOSE**

- ORBITER INTERACTION
- GENERIC TEST BED FOR ACTIVE VIBRATION CONTROL CONCEPTS

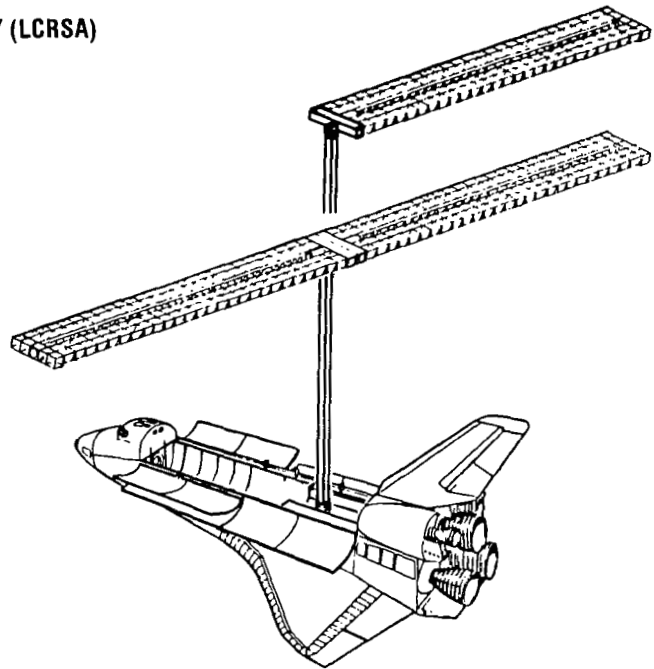
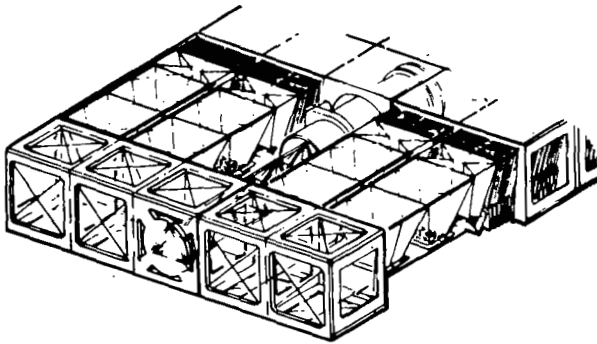

ELEMENTS OF THE EXPERIMENT

The structural elements proposed for this STEP experiment provide several options. Since both elements are positive structures during all states of deployment and retraction, each can be studied separately as well as in the combined deployment state. The disturbances associated with deployment and the interaction of the combined deployment can be measured separately. The range of frequency can be controlled for orbiter interaction testing.

- DEPLOYMENT & RETRACTION
 - BOOM NO SOLAR ARRAY
 - SOLAR ARRAY NO BOOM
 - COMBINED SOLAR ARRAY & BOOM

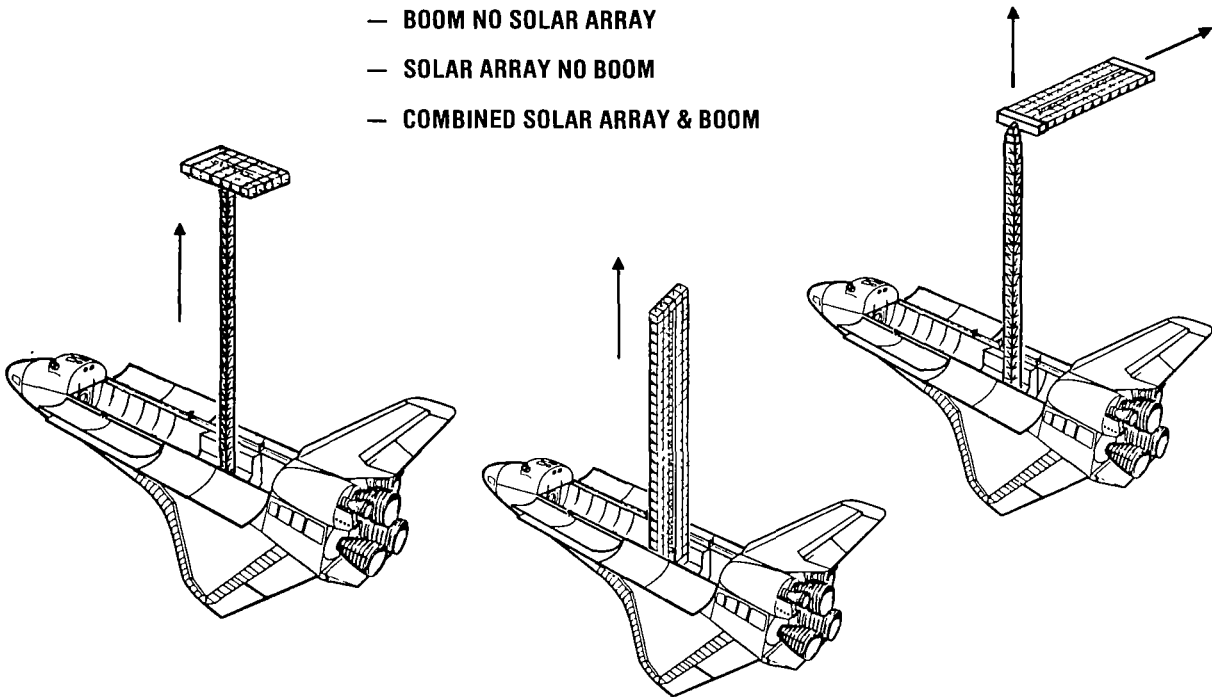

ELEMENTS OF THE EXPERIMENT (CONTINUED)

There are two classes of disturbances. Operational disturbances originate from the execution of normal orbiter mission functions and from deployment. The other class of disturbances is controlled disturbances for testing. This would include defined pulsing of the orbiter as well as the specified testing shakers distributed on the deployed structure.

This configuration will provide an opportunity to test and monitor the performance of various control concepts, ranging from simple systems such as a control loop on the solar array gimbal to distributed systems.

- **DISTURBANCE**
 - ORBITER PASSIVE
 - ORBITER STATIONKEEPING
 - ORBITER WITH DEFINED PULSING
 - SHAKERS ON STRUCTURE
 - SINUSOIDAL SWEEP
 - MULTISHAKER SINUSOIDAL DWELL
 - SINGLE OR MULTIPPOINT RANDOM
 - DEPLOYMENT DISTURBANCE
 - ARTICULATION OF SOLAR ARRAY

- **CONTROL CONCEPTS**
 - GIMBAL SOLAR ARRAY
 - GIMBAL MAST
 - DISTRIBUTED ACTUATORS & SENSORS
 - REACTION WHEELS, GYRO, ACCELEROMETERS
 - PROOF MASS ACTUATORS, ACCELEROMETERS
 - OTHERS

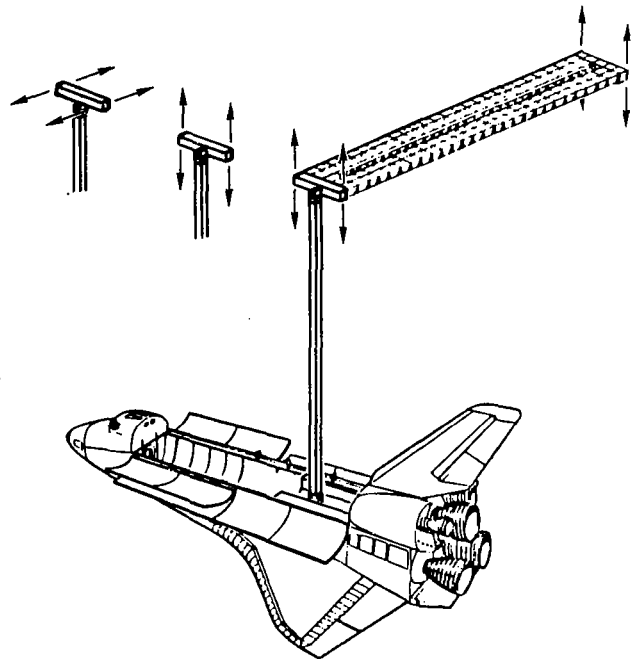

ELEMENTS OF THE EXPERIMENT (CONTINUED)

The instrumentation being considered would measure accelerations, strains, displacements, and temperatures. The deployable mast has eight elements defining a structural bay. Uniaxial measurements would be required to define loads at a cross section of the structure. Displacements due to thermal distortion of the mast and the local state of the solar concentrator may be measured by an optical ranging technique from the orbiter aft flight deck. Accelerometers and thermal couples present no unique constraints.

• MEASUREMENT

- ACCELERATIONS
- STRAINS
- DISPLACEMENTS
- THERMAL

OPTICAL
RANGING

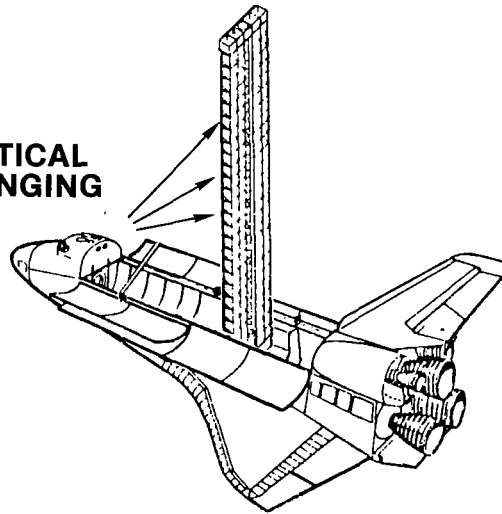

STRAIN GAGES
4 LONGERONS
4 DIAGONALS

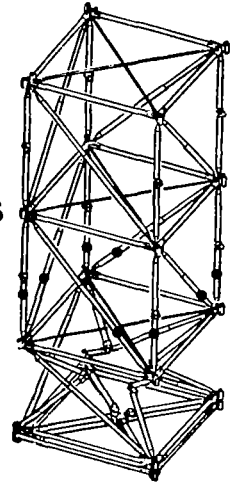

SYSTEM IDENTIFICATION

The method of system identification (that is, the measurement of plant parameters such as frequency and damping) can greatly affect the requirements or capability of the basic STEP system. Single-point and multipoint random testing require very brief test intervals. Data processing is required before the outcome can be determined. Dwell tests are more interactive in test execution. Data fidelity and results are known during testing. Test sequence times are much longer, but there is less risk of not acquiring data. These test techniques are directed toward linear behavior. Nonlinear models and behavior would require recording real-time accelerometer data to be analyzed after the flight.

- **LINEAR**
 - **FREQUENCY**
 - **DAMPING**
 - **MODAL AMPLITUDES**
- **MULTI-INPUT MULTI-OUTPUT MODEL**
- **NONLINEAR**
 - **A PRIORI FORMS**
 - **REAL-TIME RECORDS TO DEVELOP FORM**

REQUIREMENTS OF STEP

A preliminary estimate of the accommodation requirements of STEP for this proposed experiment is summarized. Included are elements of design concerns such as the cradle stiffness.

- **POWER** **kW**
 - **DEPLOYMENT & RETRACTION** **2-3**
 - **ARTICULATION OF SOLAR ARRAY** **0.5**
 - **EXPERIMENT DISTURBANCE SOURCES** **0.1**

- **DATA** **CHANNELS**
 - **GOOD HEALTH**
 - **EXPERIMENT CONTROL**
 - **SCIENTIFIC**

LATCH

INDICATORS THERMOCOUPLES

4-8 SENSORS 2 CUTOFF ACC

20-40 ACCELEROMETERS

8-24 STRAIN GAGES

20-40 THERMOCOUPLES

- **DATA PROCESSING**
 - **RECORD OR PROCESS**
 - **QUICK LOOK PROCESS & RECORD**

- **MECHANICAL**
 - **ABORT**
 - **SAFETY**
 - **ATTACHMENT**
 - **CRADLE STIFFNESS**
 - **CRADLE ATTACHMENT STRENGTH**

TYPICAL STEP/EXPERIMENT INTEGRATION SCHEDULES

Current activities on the major elements of this proposed experiment have been indicated on the STEP schedule. The deployable structure mast finishes part two of the development effort. The selected concept was designed and analyzed, and preliminary drawings were released. The next scheduled effort is to fabricate and test a ground development test article. The low concentration ratio solar array finishes the preliminary design phase. The planned full-scale ground deployment demonstration testing is being reevaluated. Design maturity may warrant going directly to an application development.

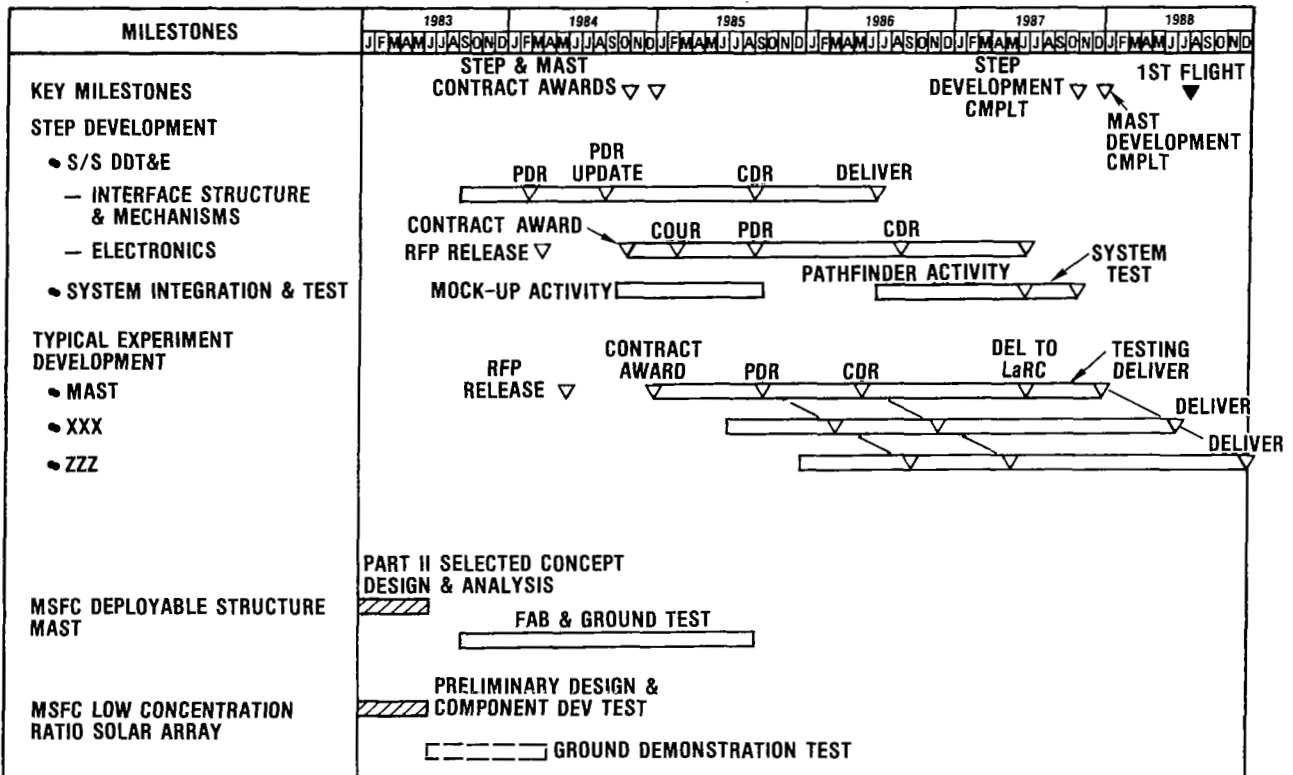

VIBRATION ISOLATION TECHNOLOGY EXPERIMENT

Claude R. Keckler
NASA Langley Research Center
Hampton, Virginia

EXPERIMENT OBJECTIVE

Large flexible platforms and manned space stations will support elements and payloads which demand low-acceleration environments because of critical processes being undertaken or because of the desire for high quality imaging. To satisfy these requirements, numerous solutions have been proposed. Among them is to provide some form of active isolation for the payload from its external environment. Such an approach is encompassed in the magnetic suspension system proposed for this experiment. The objectives (fig. 1) of this Vibration Isolation Technology Experiment are to demonstrate the viability of the magnetic suspension technology in providing the isolation of large structures elements from the external environment and to quantify the degree of isolation provided by this system.

- o ISOLATE A LARGE SPACE STRUCTURES ELEMENT FROM A BROADBAND DISTURBANCE GENERATOR

- o DEMONSTRATE APPLICABILITY OF MAGNETIC SUSPENSION SYSTEM TO VIBRATION ISOLATION

- o QUANTIFY ISOLATION CAPABILITY OF MAGNETIC SUSPENSION TECHNOLOGY

Figure 1

ARTIST CONCEPT OF ISOLATION EXPERIMENT

The approach proposed for this experiment (fig. 2) is to mount a six-degrees-of-freedom magnetic bearing suspension system at the free end of a Shuttle-attached flexible structure such as MAST. The disturbance generator, located on top of the isolation system, will be energized at selected and broadband frequencies to simulate a typical spacecraft vibration environment. Sensors located on the isolation system and the flexible structures element will be used to quantify the degree of isolation provided by this system.

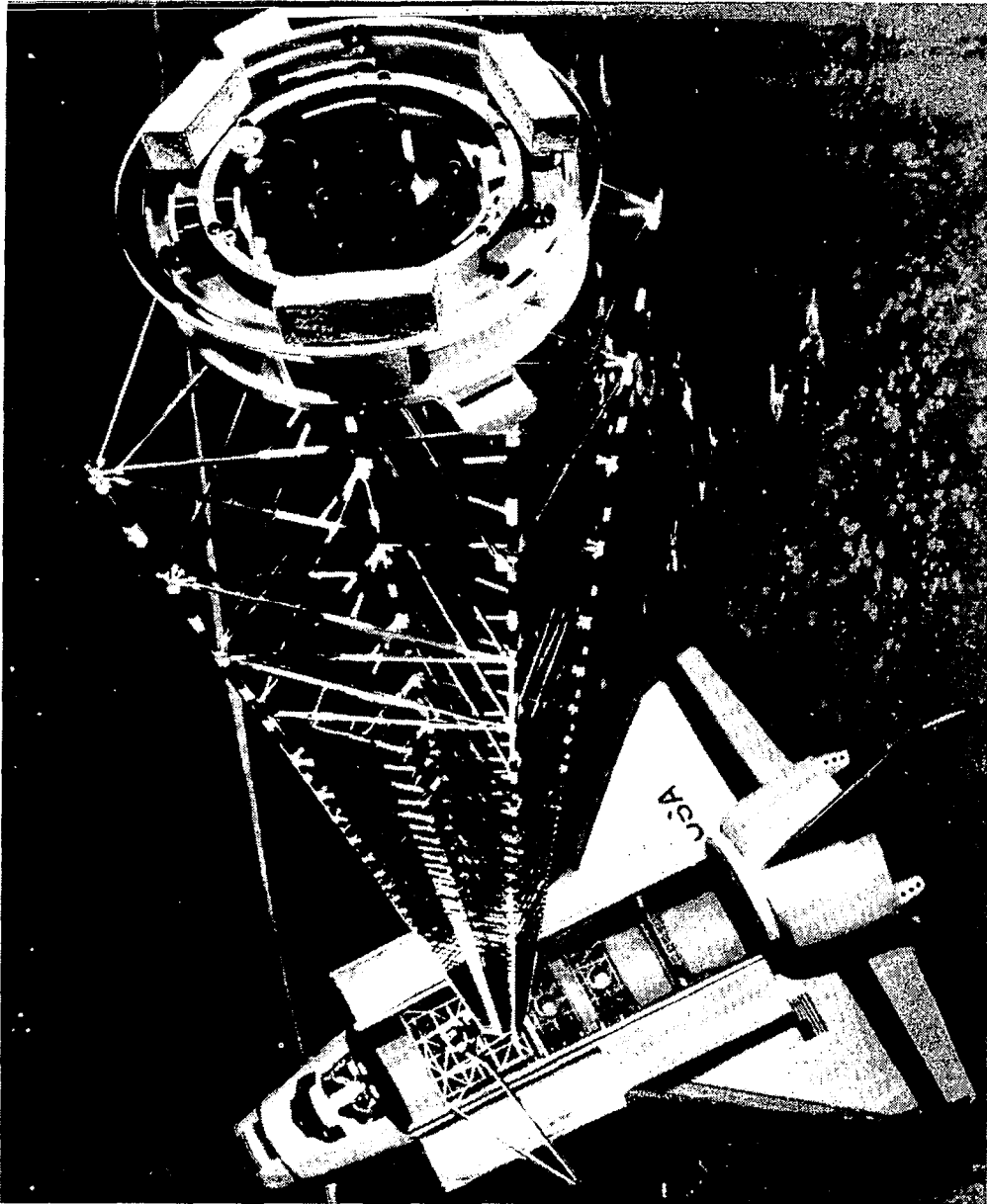

Figure 2

SCHEMATIC OF VIBRATION ISOLATION TECHNOLOGY EXPERIMENT

A schematic representation of the proposed technology experiment is depicted in figure 3. The large space structures element is deployed out of the orbiter cargo bay. The vibration isolation system mounted atop this flexible mast is equipped with a high energy broad band disturbance generator, a sensor package, and appropriate attendant electronics. These items are located on that portion of the isolation system which is levitated on a set of magnetic bearing actuators. These actuators provide the system with the desired six degrees of freedom. Although not shown on the figure, the mast is also equipped with appropriate sensors to measure the amount of vibration transmitted across the magnetic gaps from the disturbance generator. In addition, these sensors will be instrumental in determining the level and frequency content of a real spacecraft (i.e., Shuttle) disturbance environment as experienced by an orbiter-attached flexible element. The sensors on the levitated portion of the vibration isolation system will now be able to establish the amount of disturbance transmitted across the magnetic actuator gaps from the orbiter environment. These two sets of operational data will thus demonstrate the viability of the magnetic suspension technology for vibration isolation as well as permit the quantifying of the degree of isolation provided by this concept. Results from such a technology experiment will be highly beneficial to the space manufacturing discipline as well as to payloads or systems utilizing large optics such as some contemplated military missions.

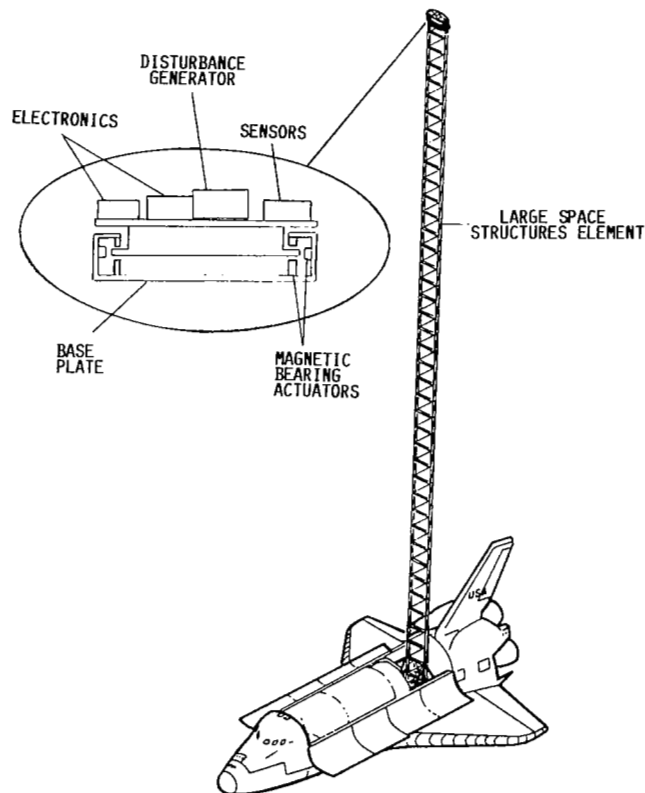

Figure 3

EXPERIMENT CHARACTERISTICS

The elements envisioned for this proposed technology experiment are anticipated to have a mass of approximately 200 kilograms. This estimate includes the vibration isolation system, the disturbance generator, the sensors, and associated electronics. However, the system weight excludes the large space structures element (e.g., MAST) which is assumed to be available to this experiment. The volume occupied by the isolation system and sundry sensor and electronics boxes is estimated at 0.25 cubic meters. Peak power consumption estimates of 750 watts are based on the assumption that all actuators apply maximum force at the same time, and that the disturbance generator is producing disturbances at maximum energy. The average power requirement of 200 watts is based on anticipated reasonable duty cycle demands to be experienced during the performance of this investigation. Command and data handling requirements are to consist of discretely and serial information which will require onboard storage capabilities as well as uplink/downlink access. The telemetry requirements have not as yet been addressed and will be determined in the course of developing this experiment. Onboard storage for post flight data analysis is estimated at 20 megabytes with an associated transfer rate of 40 kilobits per second (kbps). Commands storage is anticipated at 50 kilobytes onboard with an additional 20 kilobytes available via uplink. The demands placed on the orbiter by this experiment are expected to be small and limited to primarily power and a console in the orbiter aft flight deck area for experiment initiation and termination. Necessary crew involvement will also be limited to these functions. A listing of the experiment characteristics is given in figure 4.

WEIGHT

INCLUDES ISOLATION SYSTEM, DISTURBANCE GENERATOR, ELECTRONICS AND SENSORS	200 KG
--	--------

ENVELOPE

ISOLATION SYSTEM (INCLUDING SENSORS AND DISTURBANCE GENERATOR)	0.75M DIA. X 0.30M HIGH
ELECTRONICS BOX (2)	0.7M X 0.3M X 0.2M EACH

POWER

AVERAGE	200 W
PEAK	750 W

DATA

SERIAL DATA RATE	40 KBPS
STORAGE	20 MB
DOWNLINK (DISCRETES)	TBD

COMMANDS

STORED ONBOARD	50 KB
UPLINK	20 KB

REMARKS

CREW INVOLVEMENT MINIMAL
DEMANDS ON SHUTTLE MINIMAL
ASSUME AVAILABILITY OF MAST OR SIMILAR
FLEXIBLE STRUCTURE

Figure 4

VIBRATION ISOLATION SYSTEM LAYOUT

The vibration isolation system to be used in this experiment utilizes magnetic suspension technology to permit "complete" six-degrees-of-freedom isolation of the payload. This system utilizes six magnetic bearing actuators (MBA's), as shown in figure 5, in consort with quartz crystal force sensors to provide the feedback signal for the MBA control loop. Commands and data to and from the payload are transmitted across the magnetic gaps via multi-channel optical couplers. Power to the levitated elements is provided by a variable gap rotary transformer. Since no contacting elements are employed in this concept, the levitated payload is essentially a free-flyer constrained only by the magnetic system forces, and is thus isolated from its external environment. Latching mechanisms shown on this figure are used to secure the levitated portion of the device during launch and reentry of the orbiter. Some electronics assemblies can be mounted inside this system for signal and power conditioning as well as to minimize critical system wire lengths.

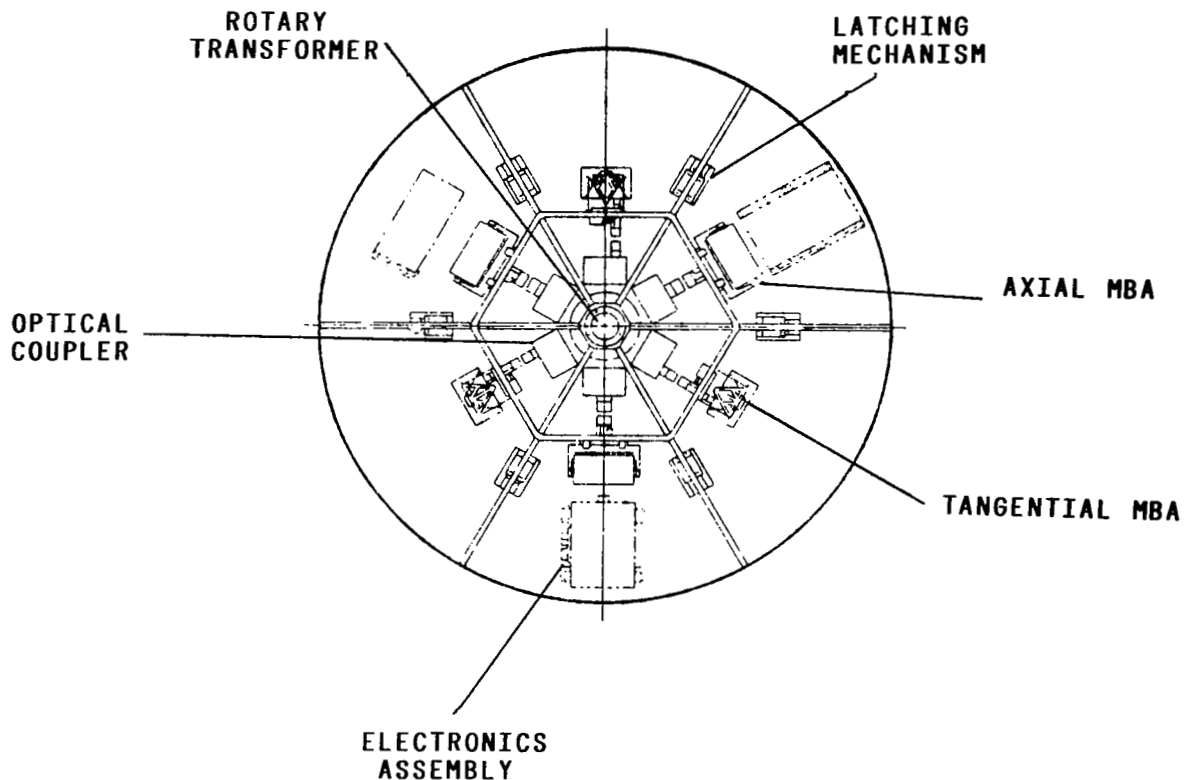

Figure 5

MAGNETIC SUSPENSION TECHNOLOGY

The technology required to support this proposed experiment has been under development for several years. To date this technology has undergone analysis, design, engineering model development, and laboratory evaluation. A typical system utilizing magnetic suspension is shown in figure 6. This device has an L-shaped rotor, to which a payload mounting plate may be attached, suspended on a set of magnetic bearings (axial and radial bearings). These bearings control the position of the rotor, and hence the payload, in translation as well as rotation. No contacting elements are used in this device. Therefore the payload is isolated and only connected to its external environment by the magnetic bearing forces. A complete description of this device is contained in reference 1.

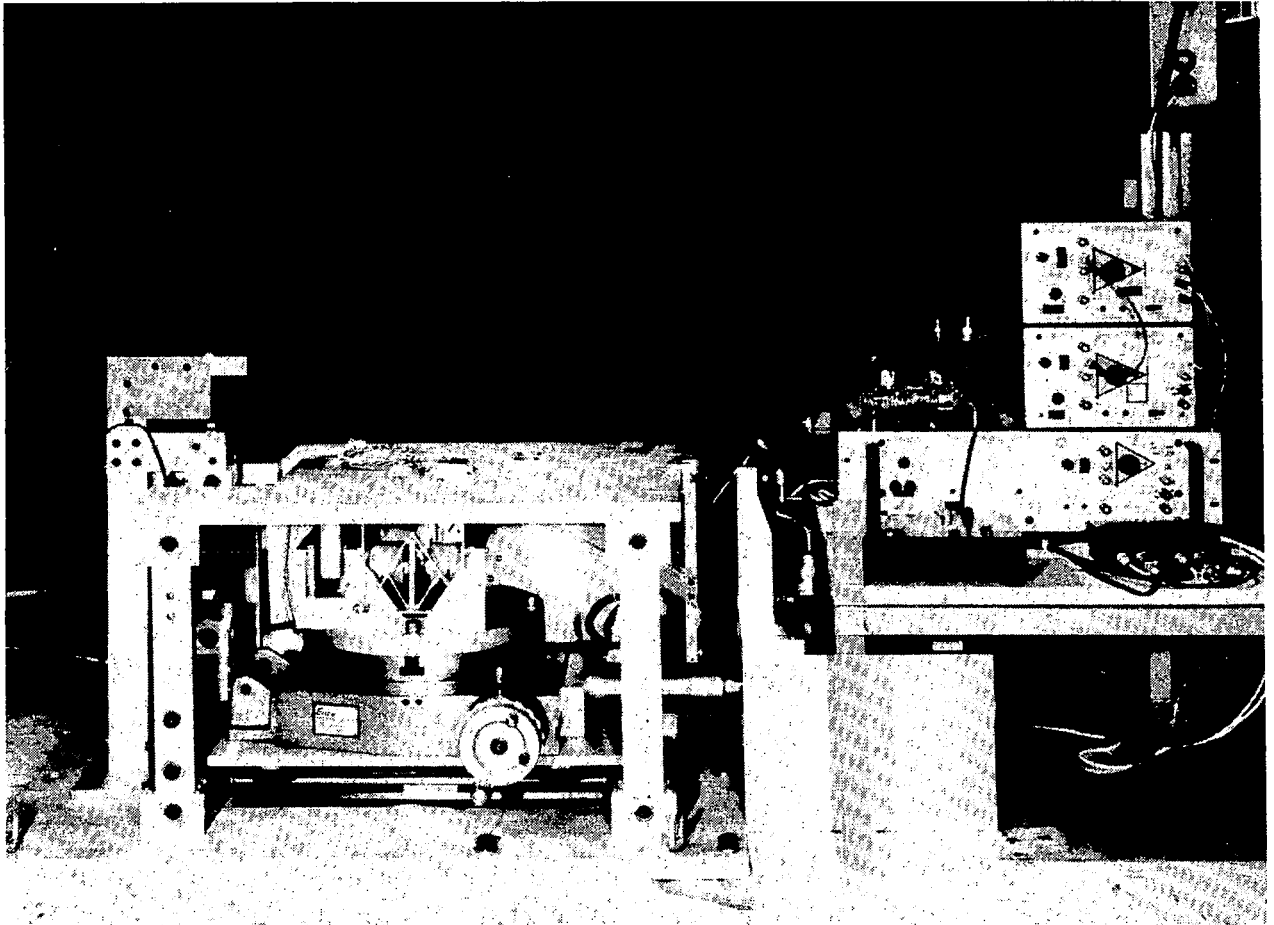

Figure 6

ENGINEERING MODEL EVALUATION

The engineering model described in the previous figure has been subjected to extensive checkout, calibration, and laboratory evaluation. A typical test setup for system stability evaluation is presented in figure 7. There the magnetic suspension system is attached to a rigid test stand to prevent contamination of the test data by resonating flexible elements. To the top plate of the engineering model hardware is attached a test payload. However, since the magnetic bearings were not designed to support such a load in a terrestrial gravity environment, a counterbalance system was utilized to simulate a zero-"g" condition (cable on right-hand side of the figure). The system was subjected to simulated Shuttle thruster firings and the impact on the payload measured with a laser interferometer (light beam around test article). Approximately one arcsecond stability while subjected to typical Shuttle disturbances was demonstrated (ref. 2).

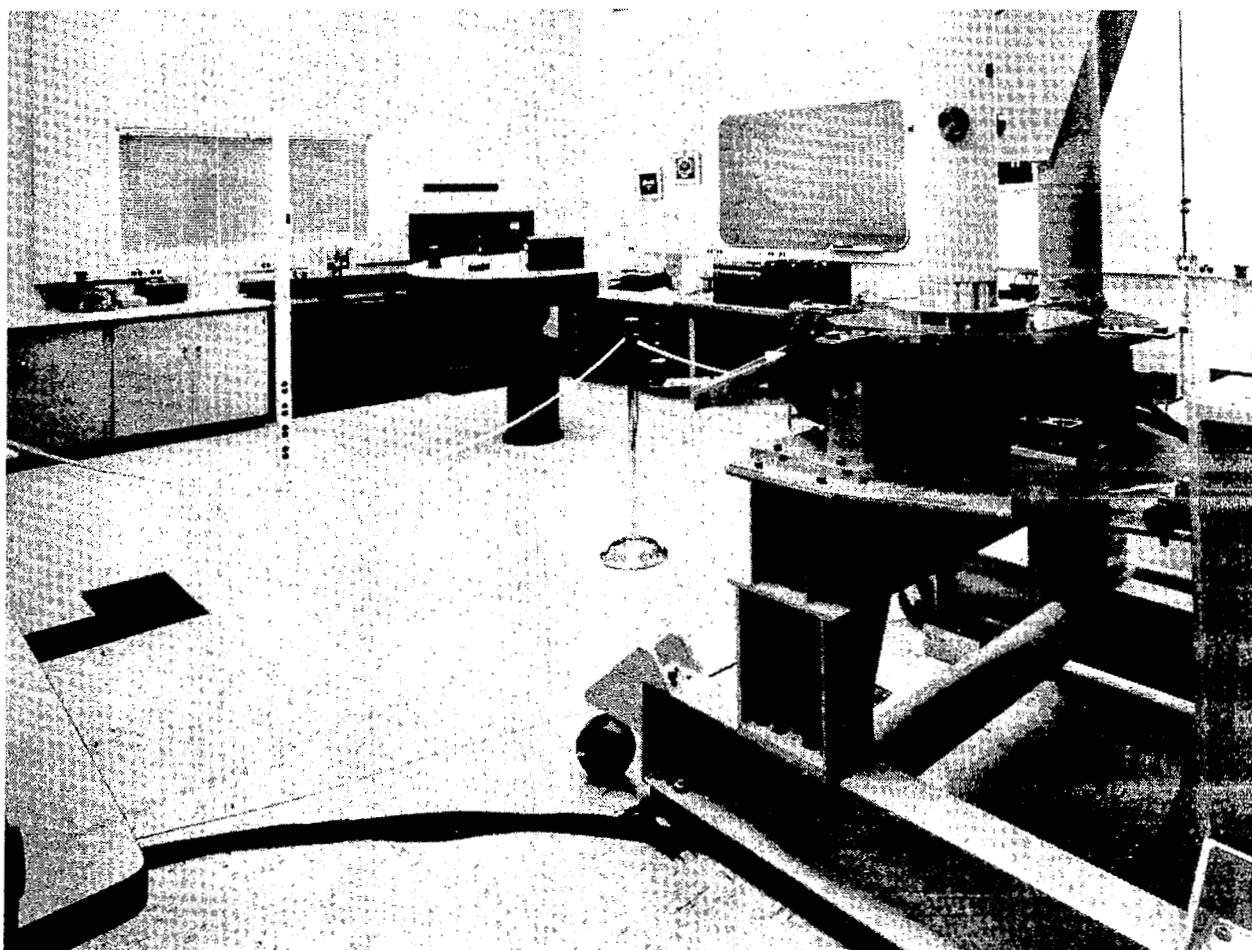

Figure 7

SINGLE STATION TEST

A single magnetic bearing actuator, identical to the ones used in the engineering model of the previous figure, was equipped with a quartz crystal force sensor. This sensor provided actual measurements of the forces applied by the actuator to the suspended payload. This combination was mounted in a single-degree-of-freedom test fixture (figure 8) and tested to determine the performance improvements gained in using a force sensor in the magnetic bearing control loop. In addition, some preliminary investigation was made into the applicability of such an actuator assembly to vibration isolation. This was conducted by attaching a shaker (located under the electronics boxes in right lower half of figure) to the base of the test article. Measurements were then made with an accelerometer located on the top plate of the test fixture. Results from these simple tests indicated a 60 dB attenuation of the disturbance across the magnetic gap. As can thus readily be seen, the technology base for the support of this experiment is in hand, and therefore, minimal efforts would be required to produce the necessary hardware elements.

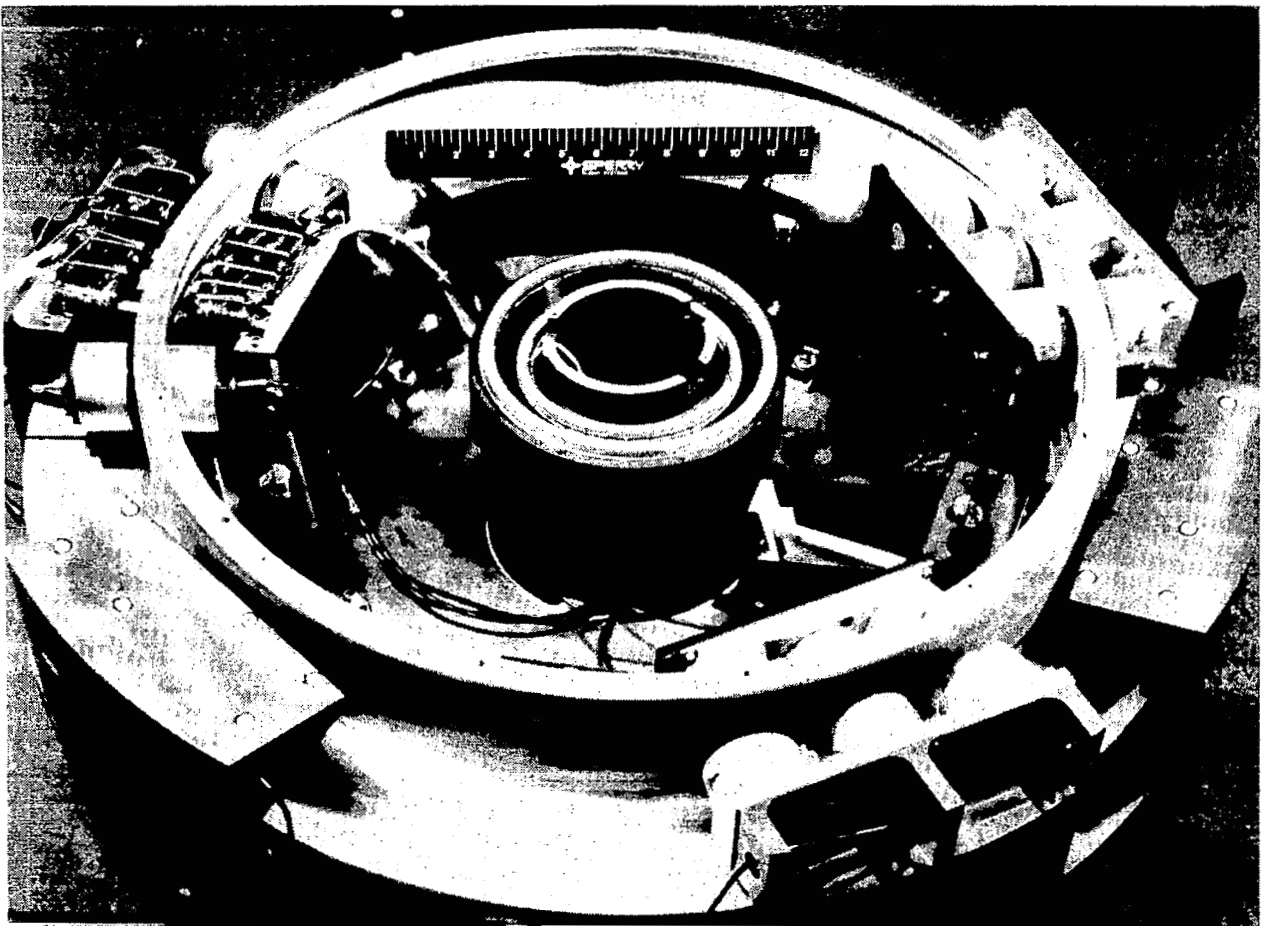

Figure 8

REFERENCES

1. Cunningham, D. C.; Gismondi, T.; Hamilton, B.; Kendig, J.; Kiedrowski, J.; Vroman, A.; and Wilson, G.: Design of the Annular Suspension and Pointing System (ASPS). NASA CR-3343, October 1980.
2. Hamilton, B. J.: Laboratory Evaluation of the Pointing Stability of the ASPS Vernier System. NASA CR-159307, June 1980.

INTEGRATED POWER/ATTITUDE CONTROL SYSTEM
(IPACS) TECHNOLOGY EXPERIMENT

Claude R. Keckler
NASA Langley Research Center
Hampton, Virginia

EXPERIMENT OBJECTIVE

Manned space stations postulated for the next decade consist of assemblies of loosely coupled modules with highly flexible appendages, such as solar cell arrays. The control of such large flexible structures has been and is being analyzed by many research organizations. Several sophisticated laboratory experiments have been developed to support these analytical efforts and to improve the level of confidence in study generated predictions on control concept capabilities. However, these experiments have been necessarily limited by the laboratory environment and by the physical size of the test article which can readily be accommodated by available test facilities. Flight evaluation of control system performance in satisfying the requirements of a large semi-rigid vehicle would be highly instrumental in verifying modeling and design techniques which will necessarily be used in the development of space station systems. The objective (fig. 1) of this experiment is to provide the essential flight validation of a control concept in satisfying the requirements of a semi-rigid vehicle as represented by the Shuttle orbiter.

**TO EVALUATE THE PERFORMANCE OF ADVANCED CONTROL AND ENERGY STORAGE
CONCEPTS IN SATISFYING THE REQUIREMENTS OF A SEMI-RIGID VEHICLE.**

Figure 1

IPACS CONCEPT

The experiment proposed herein will perform the tasks associated with the control and energy storage/power generation functions attendant to space operations. It has been shown in past studies (refs. 1 and 2) that the integration of these functions into one system can result in significant weight, volume, and cost savings. The Integrated Power/Attitude Control System (IPACS) concept is depicted in figure 2. During orbit day, power is derived from the solar cell arrays and, after appropriate conditioning, is used to operate the spacecraft subsystems. In conventional approaches, a part of the collected solar energy is stored in a bank of batteries to permit operation of the vehicle's systems during orbit night. In the IPACS concept, the solar energy is stored in the spinning flywheels of the control system in the form of kinetic energy. During orbit night, the wheels are despun and, through the use of a wheel-shaft mounted generator, power is generated for the onboard subsystems. Operating these flywheels over a 50-percent speed variation permits the extraction of 75 percent of the stored energy while at the same time preserving 50 percent of the momentum capacity for control of the vehicle. Batteries can therefore be eliminated and significant weight and volume savings realized.

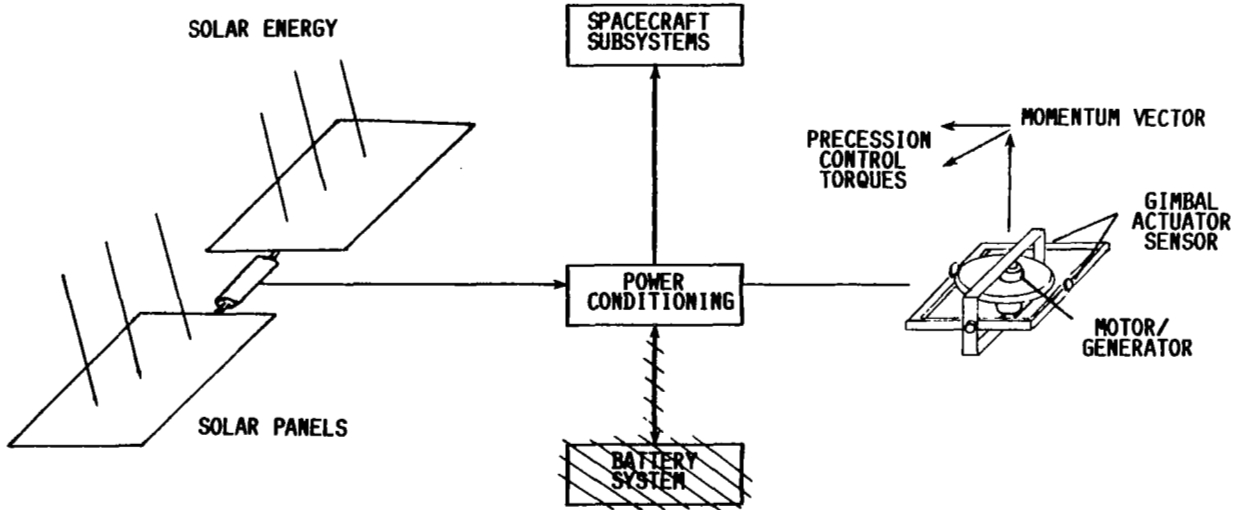

Figure 2

IPACS EXPERIMENT CONCEPT

Three double-gimbal energy/momentum storage assemblies will be mounted on a typical pallet structure along with appropriate electronics and sensors, as shown in figure 3, for integration into the Shuttle cargo bay. These devices will be sized so as to permit control of the orbiter's attitude while in a geocentric orientation. The Shuttle's reaction control system will only be used to allow for desaturation of the momentum storage devices if it should prove necessary. Inertial sensors located in close proximity to the storage assemblies will be used alternately with Shuttle sensors to permit the evaluation of a control system with and without collocated sensors. Wheel speeds of these assemblies will be varied to demonstrate the system's capability of performing simultaneously the functions of the power and control subsystems.

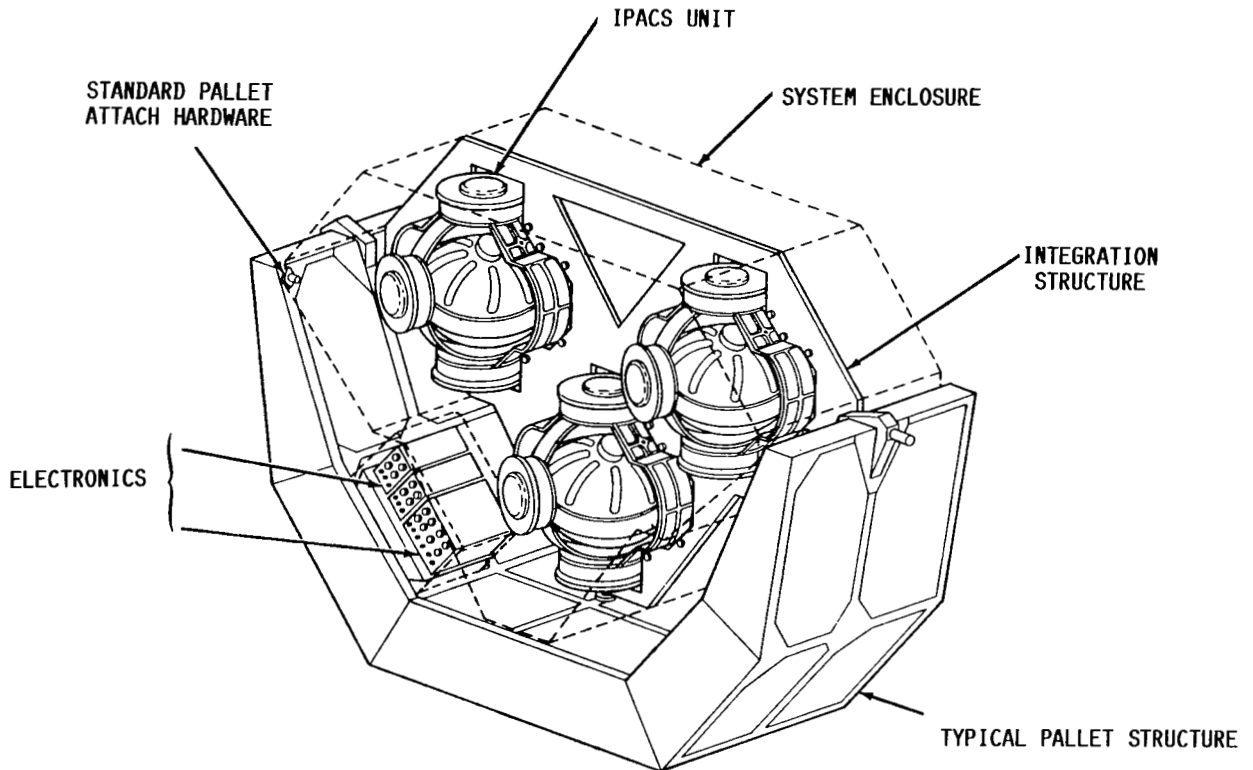

Figure 3

IPACS EXPERIMENT BLOCK DIAGRAM

A schematic representation of this experiment is shown in figure 4. The experimental sequence is initiated from the control/display console located in the Shuttle aft flight deck area. Crew generated commands connect the IPACS assemblies to the orbiter power bus to place the system in a zero-momentum configuration, energize the flywheels, and start up the control computer and system electronics. Once 50 percent wheel speed has been reached, control of the orbiter is turned over to the momentum storage system as opposed to the vehicle's vernier reaction control system (VRCS). Shuttle motion is detected by the sensor module. That information is relayed to the control computer which in turn generates the proper commands to correct vehicle attitude errors. Wheel speeds will be varied to demonstrate the dual function capability of this concept. During the discharge cycle, power generated by the flywheels will be routed to a load bank and will be dissipated in the form of heat. From the control/display console, the crew will be able to access the control computer and thus monitor and/or command the IPACS experiment. Data gathered during the experiment period will be stored on a mass storage unit for post flight analysis. Termination of the experiment is effected by the crew from the control/display console by commanding the system to zero wheel speeds and gimbal caged position, and then disconnecting the experiment from the power source.

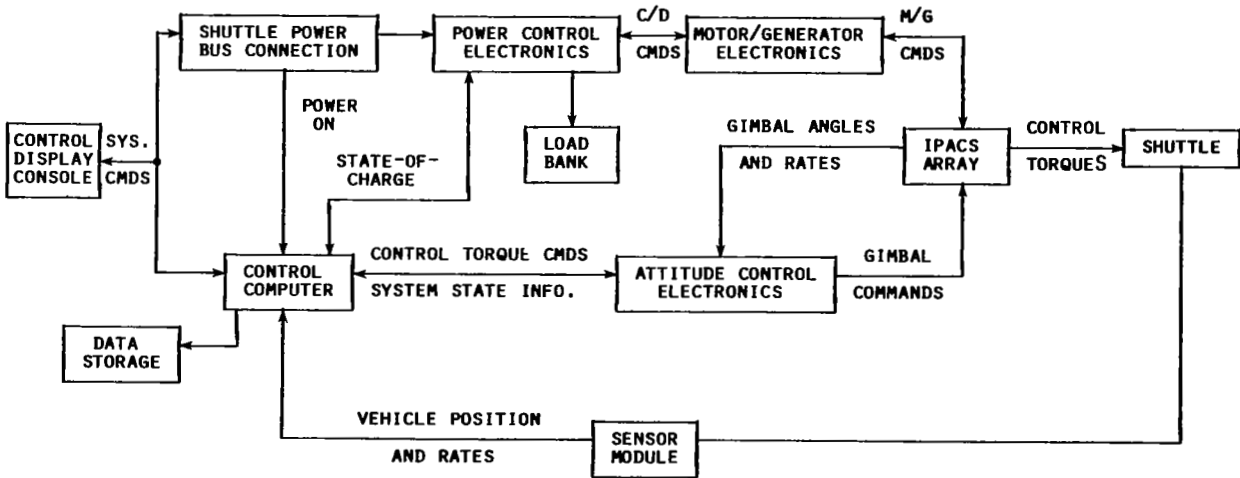

Figure 4

EXPERIMENT CHARACTERISTICS

Some basic characteristics of the proposed IPACS Technology Experiment are presented in figure 5. Based on current estimates, it is anticipated that the experiment package, including the major integration hardware, will weigh just under 1000 kilograms and will occupy an equivalent volume of approximately one-half of a Spacelab pallet. Power to spin up the flywheels and provide maximum torque from all gimbals is expected to peak at 3.5 kilowatts. The average operating power to respond to normal duty cycle demands of maintaining attitude and charge-discharge cycling of the wheels is anticipated to reach a level of 1.5 kilowatts. Data to be stored include discrete and serial data with a rate of 25 kilobits per second (kbps) and will require a storage capacity of 10 megabytes (MB) and 45 MB for the discrete and serial data respectively. Downlink of some discrete event flags may be required with the rate and volume to be determined at a later time. Onboard storage of experiment required software and commands as well as uplink of some commands are indicated here with the uplink rate to be established later. It is currently anticipated that the goals of this experiment can easily be accomplished in one day. Desirable features for this operation include an access to information from Shuttle attitude sensors to evaluate control system performance with noncollocated sensors, and initialization of the experiment from a crew operated console in the aft flight deck. In order to minimize this experiment's size and cost, it is recommended that, for the experiment operational period, the orbiter be placed in a geocentric orientation with the X-axis perpendicular to the orbit plane (X-POP), thereby reducing moment storage requirements.

<u>WEIGHT</u>	
3 DOUBLE GIMBAL UNITS	780 KG
ELECTRONICS AND INTEGRATION STRUCTURE	218 KG
 <u>ENVELOPE</u>	
DOUBLE-GIMBAL UNIT (3)	1.22M X 1.07M X 0.76M EACH
ELECTRONICS BOX (4)	0.75M X 0.4M X 0.4M
SENSOR PACKAGE (1)	0.6M X 0.4M X 0.3M
TOTAL EQUIVALENT VOLUME REQUIRED	HALF OF PALLET
 <u>POWER</u>	
AVERAGE	1.5 KW
PEAK	3.5 KW
 <u>DATA</u>	
DISCRETE DATA STORAGE	10 KB
SERIAL DATA STORAGE	45 MB
SERIAL DATA RATE	25 KBPS
DOWNLINK	TBD
 <u>COMMANDS</u>	
DISCRETES, GAINS, CONTROL LAWS, ETC.	60 KB
UPLINK	35 KB
 <u>REMARKS</u>	
TOTAL DURATION	1 DAY
PREFERRED ORIENTATION	X-POP, GEOCENTRIC PTG
ACCESS TO SHUTTLE ATTITUDE SENSORS DESIRABLE	

Figure 5

CONTROL TECHNOLOGY BACKGROUND

This proposed experiment is supported by a large volume of research in the areas of control system design, control law developments using classical and modern control theory, and also generation and evaluation of advanced control system hardware. An example of such hardware is the Skylab prototype control system shown in figure 6. It consists of three double-gimbal control moment gyros (CMG's) each having a momentum capacity of about 1400 N-m-s and output torque capability of 237 N-m per gimbal axis. These units were employed in computer simulations, with control hardware in the loop, of the Skylab mission (ref. 3). Results from these efforts were highly instrumental in the resultant successful Skylab missions.

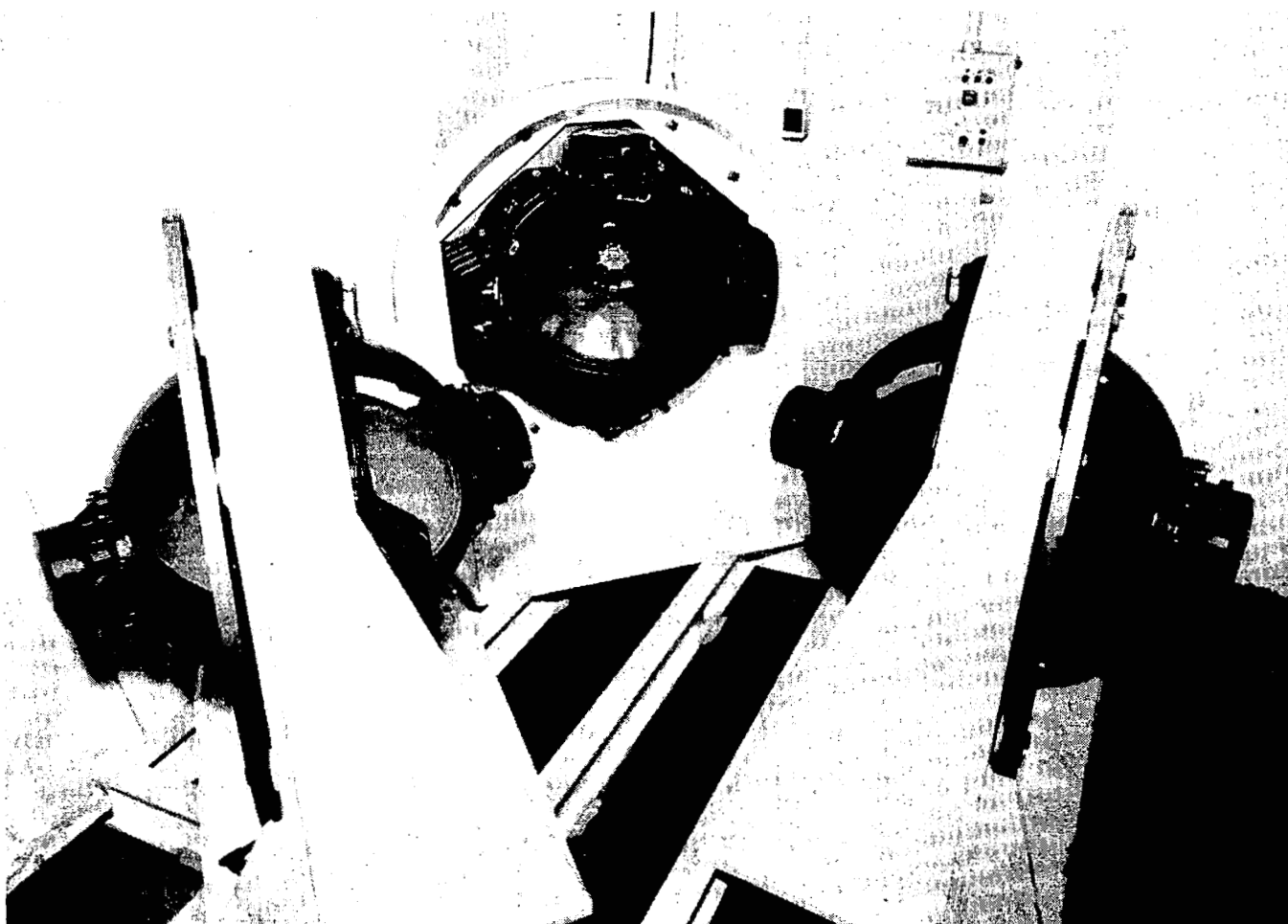

Figure 6

IPACS PROTOTYPE HARDWARE

The concept of integrating the functional requirements of the power and control subsystems into a single system has been addressed in references 1 and 2. These efforts culminated in the fabrication of the hardware shown in figure 7. The device shown here is the rotating assembly of an IPACS unit, of which three are required for the experimental package discussed previously. It is a laboratory unit capable of storing 1.5 kilowatt-hours of energy and of delivering 2.5 kilowatts of power at 52 volts d.c. for other subsystem uses. For control purposes, this unit has a momentum storage capacity ranging from 1430 N-m-s at half-speed to 2860 N-m-s at full wheel speed. Although this unit has not undergone any environmental testing, the impact of the launch and operational environment to which such hardware will be subjected has been considered during the design phase. Therefore, a major portion of the technology required by this experiment is in hand.

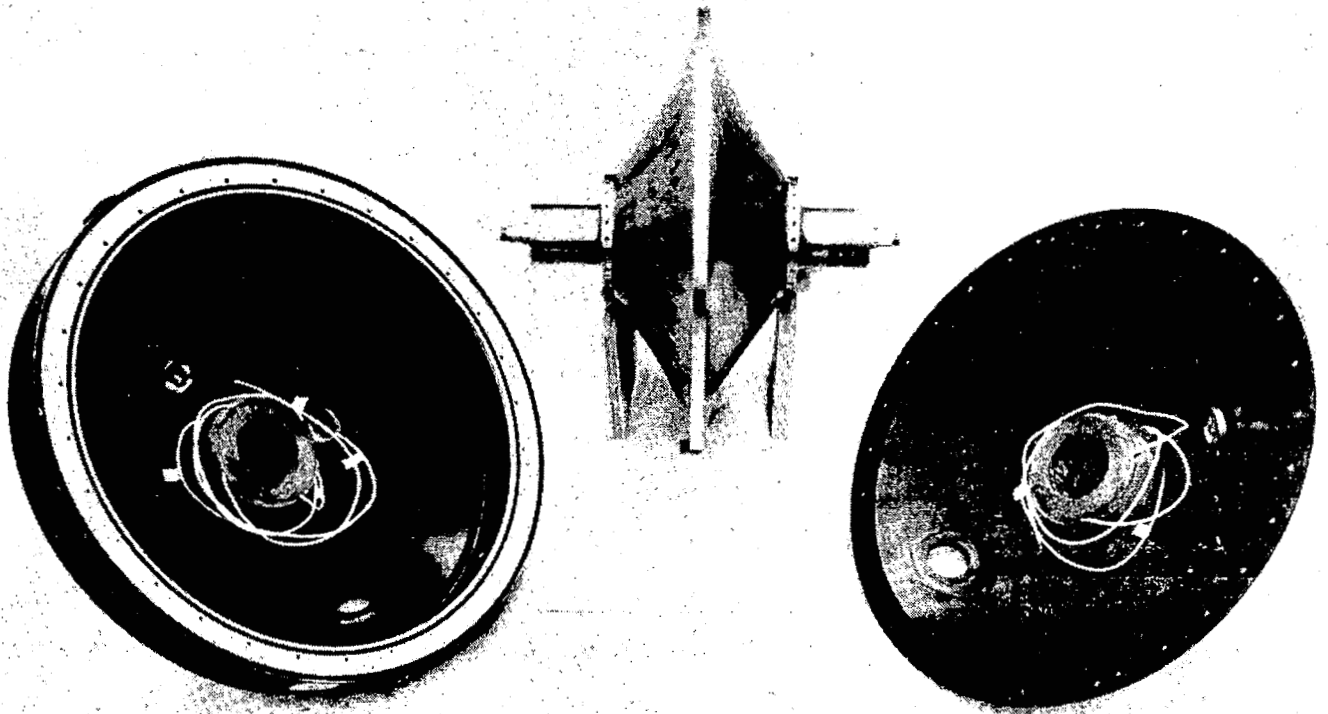

Figure 7

REFERENCES

1. Notti, J. E.; Cormarck, A., III; and Schmill, W. C.: Integrated Power/Attitude Control System (IPACS) Study, Volume I - Feasibility Studies. NASA CR-2383, April 1974.
2. Will, R. W.; Keckler, C. R.; and Jacobs, K. L: Description and Simulation of an Integrated Power and Attitude Control System Concept for Space-Vehicle Application. NASA TN D-7459, April 1974.
3. Keckler, C. R.; Kyle, R. G.; Will, R. W.; and Woolley, C. T.: Real-Time Digital-Computer-Hardware Simulation of a Spacecraft with Control-Moment-Gyroscope Stabilization. NASA TM X-2069, September 1970.

INVESTIGATION OF ARTICULATED
PANEL DYNAMICS

Clyde V. Stahle, Jr.
General Electric Company
Space Systems Division
Valley Forge, Pennsylvania

INTRODUCTION

The purpose of this paper is to propose an articulated panel dynamics experiment to evaluate present analysis and ground test methods as well as damping effectiveness. The experiment uses an existing panel design which has been extensively analyzed and tested. These data provide a firm basis for evaluating the adequacy of panel analysis and ground test methodology. The key issues for future large space structure panel designs are addressed: (1) the critical launch transient and vibroacoustic loading; (2) the deployment analysis adequacy including air and gravitational effects; and (3) the orbital resonant frequencies and mode shapes of deployed panel assemblies. By using an existing mature design that has been thoroughly tested, the effort can focus on correlation of actual flight results with existing predictions. A second panel assembly incorporating passive damping is proposed to provide a direct measure of damped panel benefits that can be obtained. These benefits include: (1) reduced launch loads and responses; and (2) highly damped deployed modes. The passive damping portion of the experiment will use the damping technology currently being developed for AFWAL under the RELSAT contract. Existing GE space-qualified viscoelastic epoxy, in combination with composite materials or an alternate more effective damping material, will be used.

This paper first examines some spacecraft being studied to determine the applicability of articulated panel designs to future spacecraft. The experiment objectives are then described, followed by a description of the proposed DSCS III solar array test article and the existing ground test data. Finally, the expected results are outlined.

Some future space missions being considered at GE are illustrated in the attached figure. In addition to these large Shuttle-deployed spacecraft, the Space Station is also a viable program for advanced space structures applications.

The Customer Premise Service (CPS) Satellite is a 5- to 10-kW advanced broadcast satellite currently under study by NASA Lewis. The configuration shown was developed by General Electric Space Systems Division for NASA to be launched on the STS/IUS or STS/Centaur-G to its geosynchronous operating orbit. The design features deployable rigid reflectors for transmit and receive offset feed antennas and a large frame-membrane solar array having a total span from 30 to 50 meters. Key drivers for CPS structural performance will be antenna precision pointing and dynamic interaction of the large flexible solar array with the attitude sensing and control system. Antenna deployment, retention, and distortions could be evaluated on the STEP facility along with verification of any array wing dynamics.

A typical large deployable offset feed antenna configuration is shown for the Land Mobile Satellite. Reflectors and booms for these antenna systems will be from 30 to 60 meters in diameter and/or length. The STEP facility will provide the capability for STS attached evaluation of antenna, boom, and feed assembly deployment and dynamic behavior.

The High-Resolution Soil Moisture Radiometer (HRSMR) is representative of future large space erectable space structures. HRSMR is an assembly of waveguide antenna array panels to be progressively erected from STS. The overall size of the configuration shown is approximately 75 meters square, and it requires multiple STS flights to complete the total structure and installations. STEP provides an opportunity to develop erectable STS-deployed structural modules and erection procedures with the RMS and EVA.

Nuclear reactors for 50 to 200 kW of spacecraft power are under study and will probably require multiple STS launch and final assembly in space in the higher power configurations. These systems require spacing the reactor 30 to 100 meters from the spacecraft to meet radiation shielding requirements. Deployment booms and in-space segment mating techniques and procedures can be developed with the STEP facility.

FUTURE SPACE MISSIONS

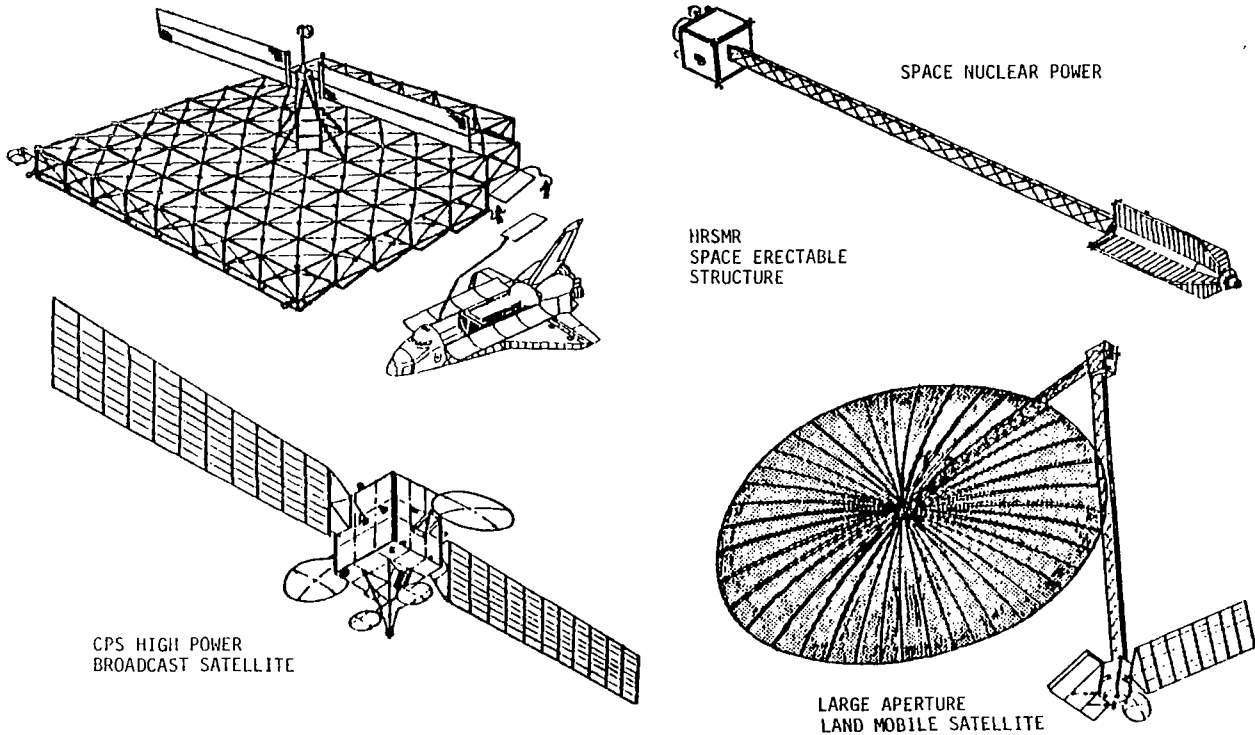

ERECTABLE RADIATOR CONCEPT

This figure shows an erectable radiator concept currently being considered for an advanced military spacecraft requiring a large heat rejection area. It is approximately 15 feet long and 5 feet wide. This large, low surface density panel structure will be designed by launch transient loading and the lift-off vibroacoustic loads with some additional consideration of the deployed stiffness requirements. The methodology to provide an efficient lightweight design includes accurate evaluation of launch and deployment loads and the accurate prediction of the resonant frequency of the deployed hinged structure.

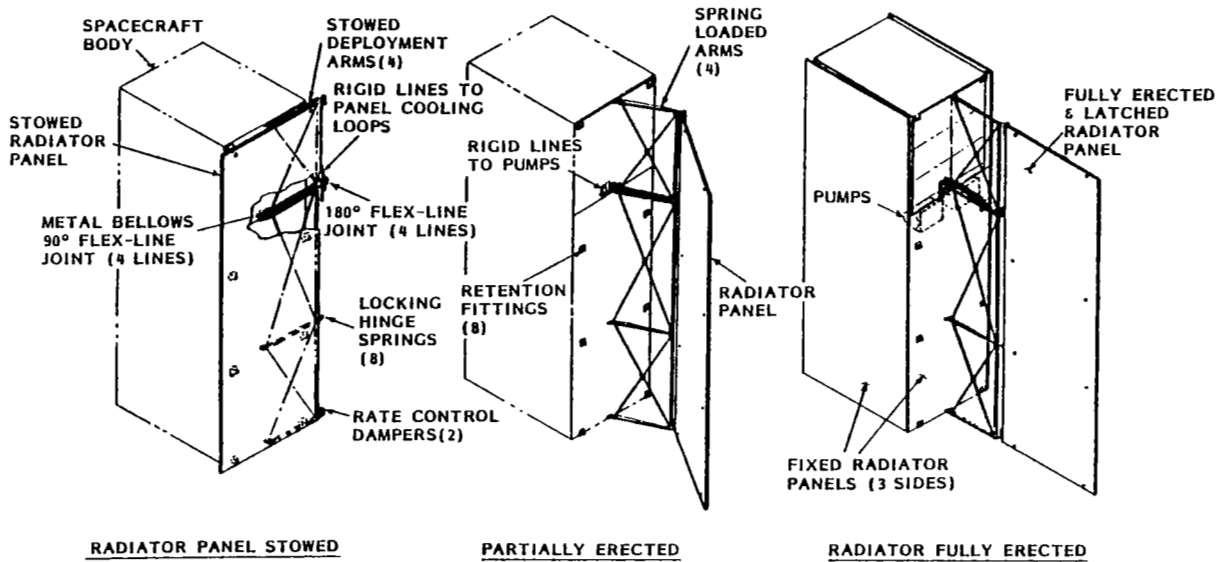

DEFENSE SATELLITE COMMUNICATION SYSTEM

The present DSCS III spacecraft design incorporates a relatively large solar array. The two solar array wings are folded and secured against the main structure. Each solar array wing consists of two panels and a yoke. The solar array is deployed by the release of strain energy contained in rotary springs at the hinge lines. When deployed, the solar array spans 32 feet. The solar array design is critical for deployed resonant frequency, deployment loads, and launch loads. It is a mature design that has been developed using current analysis/test methodology.

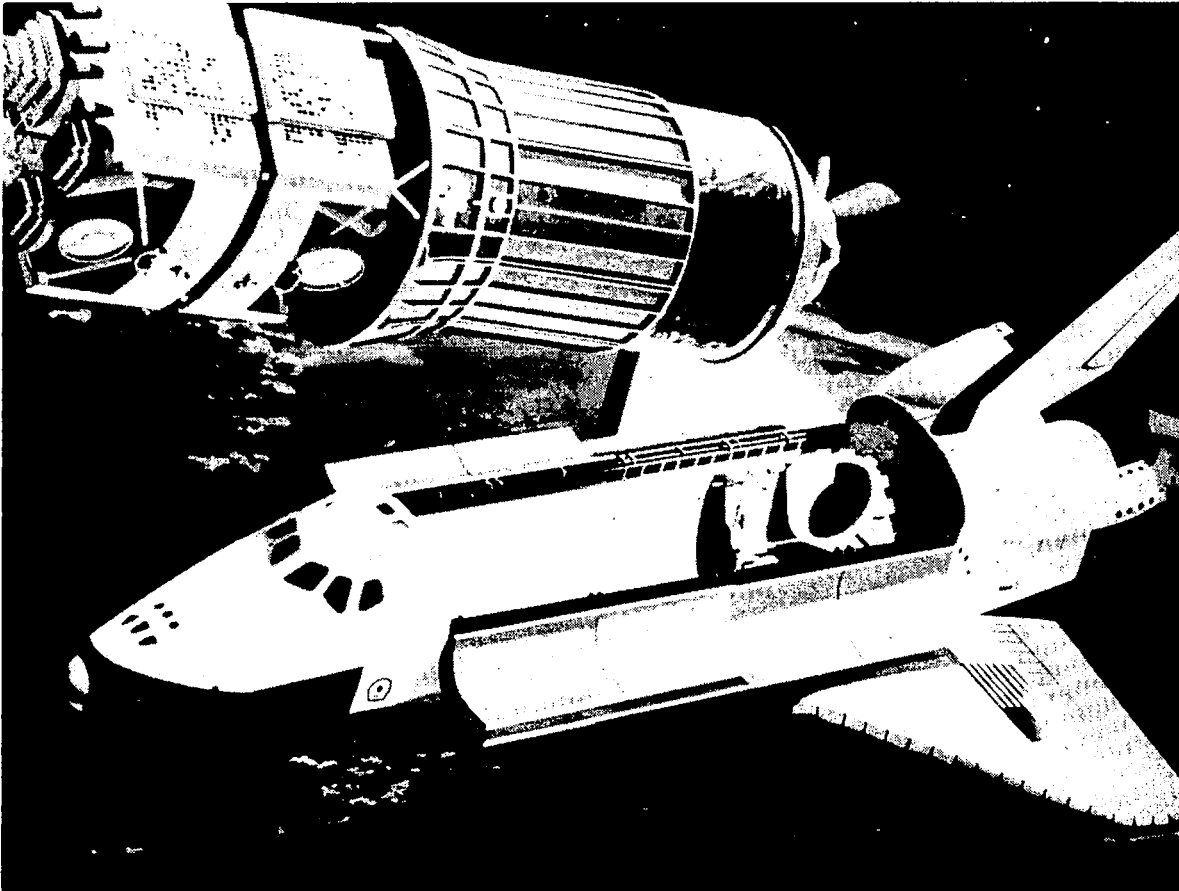

EXPERIMENT OBJECTIVES

The emphasis of this experiment is on the correlation of analysis, ground test, and flight performance. All mission phases critical to the design are included. During launch in the stowed condition, the transient and vibroacoustic launch loads and the stowed thermal stress will be evaluated. Deployment dynamics and loads as well as deployed dynamics will provide a critical evaluation of present ground test methods excluding aerodynamic effects, ground deployment aids, and gravity. The effectiveness of passive damping in reducing dynamic launch loads and orbital response will also be examined. Because the solar array design development has been supported by extensive analysis and test, costs can be directed toward flight evaluation and correlation. A check on the status of current methodology is provided for extrapolation to large space structure designs.

CORRELATE ANALYSIS, GROUND TEST AND FLIGHT

- TRANSIENT AND VIBROACOUSTIC LAUNCH LOADS
- STOWED THERMAL STRESS
- DEPLOYMENT DYNAMICS AND LOADS
- DEPLOYED DYNAMIC CHARACTERISTICS
- EFFECTIVENESS OF PASSIVE DAMPING

EXTENSIVE ANALYSIS AND TESTS OF
DSCS-III SOLAR ARRAY PROVIDE
BASIS FOR EVALUATING CURRENT ANALYSIS
AND GROUND TEST METHODOLOGY

STOWED ANALYSIS AND TESTS

The stowed solar array has been thoroughly analyzed and tested. The analysis has been substantiated by modal tests and has included multiple load cycle analyses. A comprehensive thermal analysis was performed to verify the design adequacy under solar radiation loads in the stowed configuration. The array was thoroughly stressed by high-level sine vibration and acoustic tests.

- MULTIPLE LOAD CYCLE ANALYSIS - PRELIMINARY, DESIGN, VERIFICATION
- COMPREHENSIVE THERMAL STRESS ANALYSIS
- MODAL TEST
- HIGH-LEVEL SINE VIBRATION TEST - RESPONSE LIMITED
- ACOUSTIC TEST

EXTENSIVE ANALYSIS AND TESTING PROVIDES MATURE ANALYTICAL MODELS
--

STOWED MODAL TEST

The modal test indicated a large unanticipated aerodynamic interaction. The stowed array provided a small air gap between panels. Single-point random modal tests showed that the fundamental in-phase panel bending mode matched the analytical prediction that included an estimate of the virtual air mass. However, the out-of-phase panel mode was approximately half the predicted resonant frequency. Subsequent experimental investigations showed this to be caused by pumping of the air in the small gap between panels which increased the panel mass by a factor of 4. Subsequent analytical estimates (informal memorandum by Larry D. Pinson and B. R. Hanks, NASA Langley) including the aerodynamic effects verified this large resonant frequency reduction. This is an example of unanticipated effects in current procedures.

STACKED SOLAR ARRAY TEST CONFIGURATION

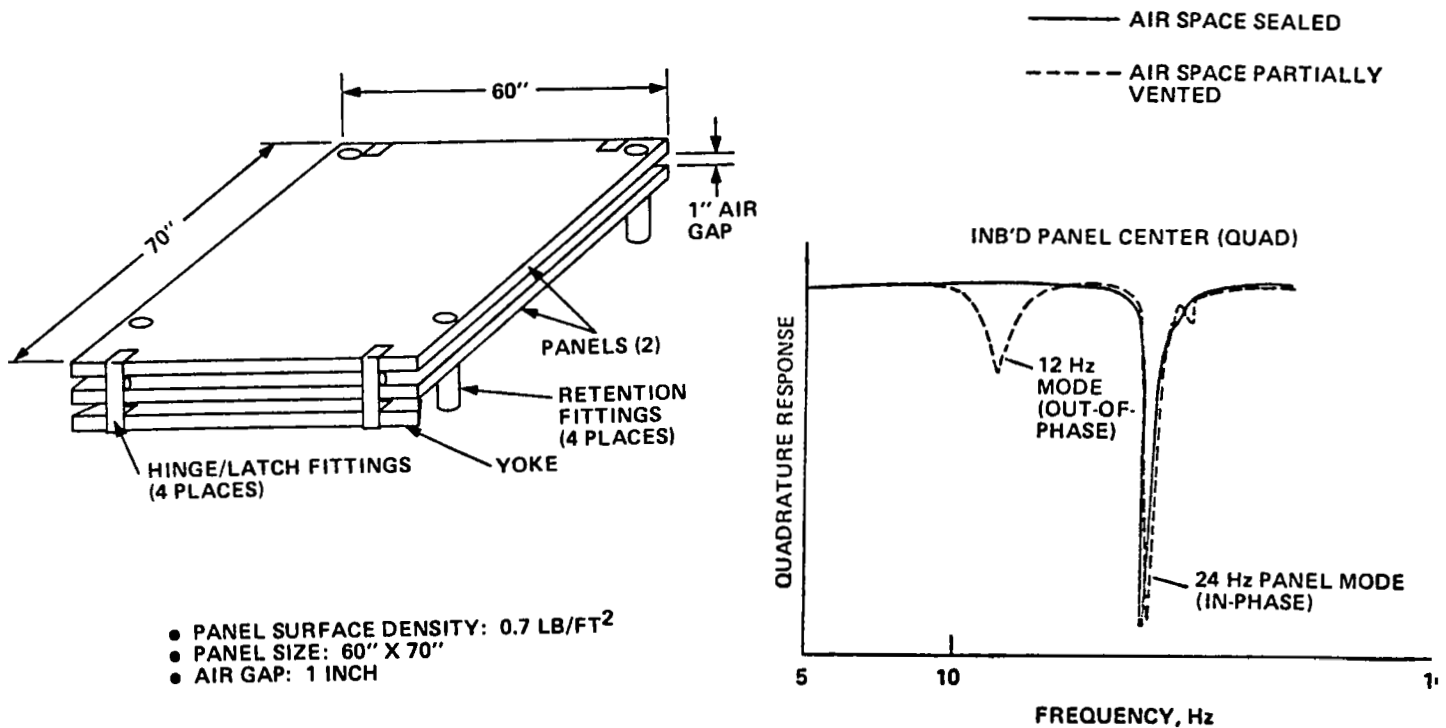

SOLAR ARRAY DEPLOYMENT SEQUENCE

The solar array deployment results from the release of strain energy stored in rotary springs at the hinges. There are no dampers in the system. Deployment takes place in two phases. During phase 1, the inboard and outboard panels are constrained to move together by using a latch mechanism located at the extreme of the outboard panel. The two panels are kinematically linked to the yoke and centerbody by a synchronization system which constrains the included deployment angle between the two panels and yoke to be twice the angle between the yoke and centerbody. Near the conclusion of phase 1 when the yoke and panels are near normal (within approximately ten degrees) to the centerbody, the latch on the outboard panel is initiated mechanically and the outboard panel starts the final phase 2 deployment sequence. This deployment sequence is shown pictorially. Over center cams are provided at each hingeline which "lock" the panels and yoke together to preclude rebound from respective latch-up impacts and assure orbital stiffness requirements are met. This sequence provides a controlled deployment which precludes potential recontact of the solar arrays with the satellite which would be possible if no synchronization mechanisms were employed. Critical design considerations include adequate energy to assure that the array deploys and latches without causing excessive loads in the hinge fittings and stops.

DSCS III ACOUSTIC TEST

The DSCS III spacecraft with the solar arrays in the stowed configuration has been tested to the simulated launch acoustic environment. The test was performed in the GE-SSD 20,000 ft.³ reverberant acoustic test chamber. A complete satellite with thermal insulation was instrumented and tested to the expected launch acoustic levels. Each flight spacecraft undergoes a similar test.

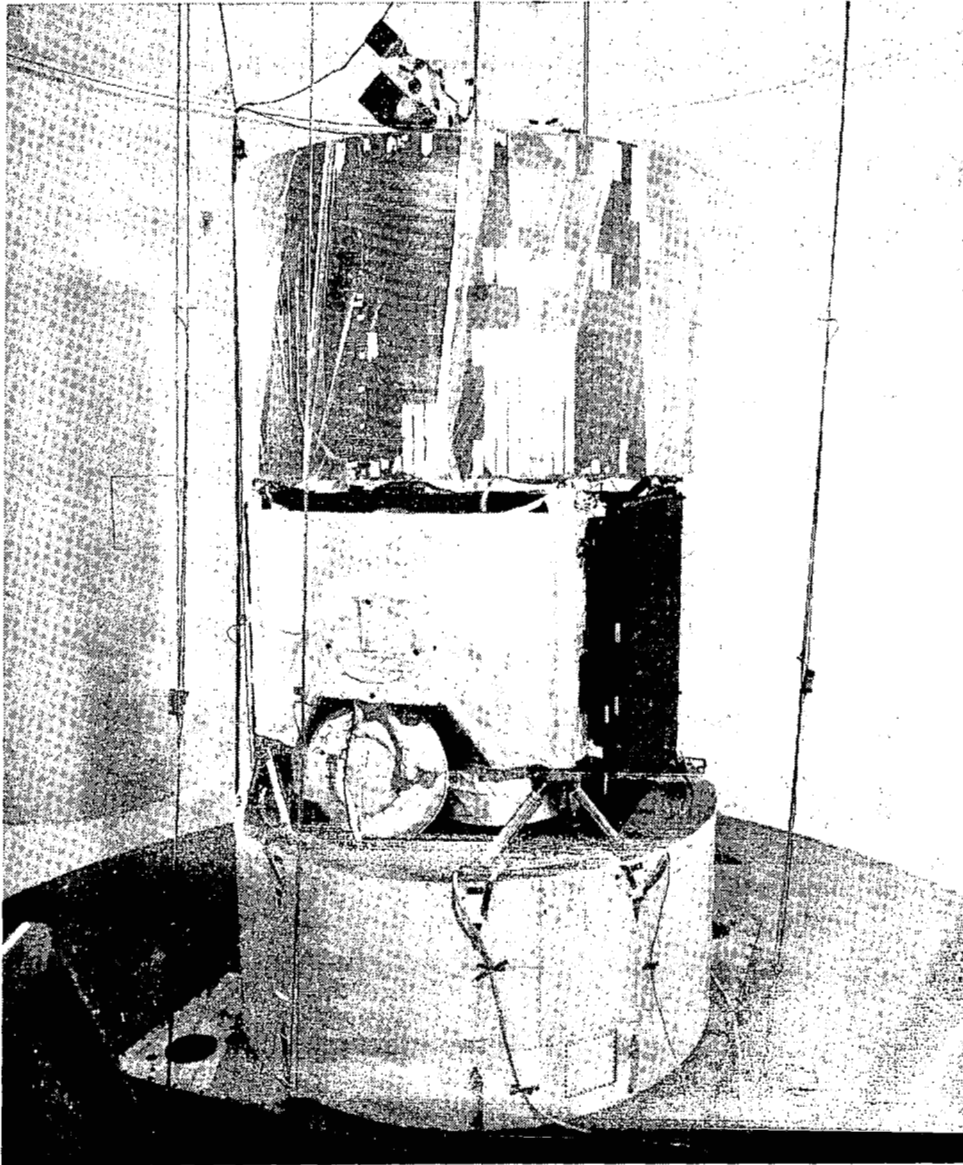

SOLAR ARRAY DEPLOYMENT SEQUENCE

The solar array deployment results from the release of strain energy stored in rotary springs at the hinges. There are no dampers in the system. Deployment takes place in two phases. During phase one, the inboard and outboard panels are constrained to move together by using a latch mechanism located at the outboard panel extremities. The two panels are kinematically linked to the yoke and centerbody by a synchronization system that constrains the included deployment angle between the two panels and yoke to be twice the angle between the yoke and centerbody. Near the conclusion of phase one, when the yoke and panels are near normal (within approximately ten degrees) to the centerbody, the latch on the outboard panel is initiated mechanically, and the outboard panel starts the final phase two deployment sequence. This deployment sequence is shown pictorially. Over-center cams are provided at each hinge line; these cams "lock" the panels and yoke together to preclude rebound from respective latch-up impacts and to assure that orbital stiffness requirements are met. This sequence provides a controlled deployment which precludes potential recontact of the solar arrays with the satellite which would be possible if no synchronization mechanisms were employed. Critical design considerations include adequate energy to assure that the array deploys and latches without causing excessive loads in the hinge fittings and stops.

BACKGROUND

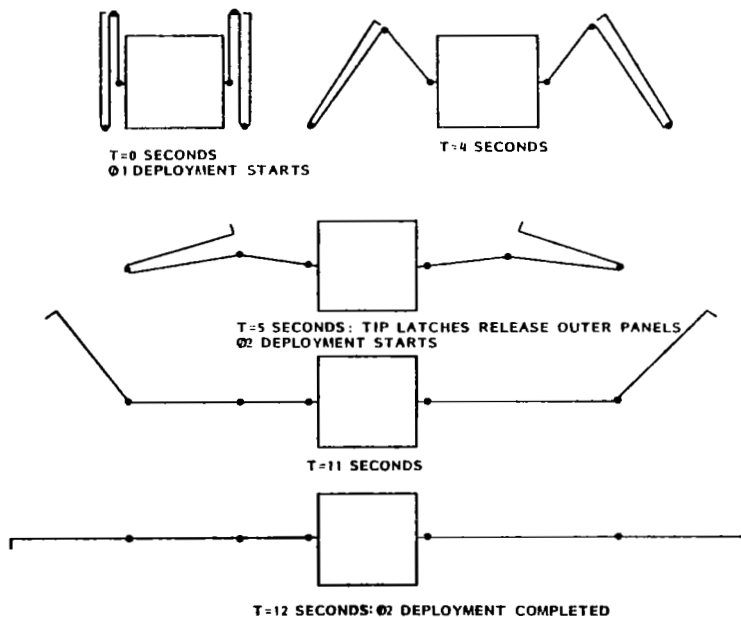

DEPLOYMENT TEST ANALYSIS COMPARISON

Good correlation of measured angular displacements with analytical predictions was obtained. The analysis includes corrections for the aerodynamic drag which doubles the deployment time when standard deployment springs are used. The effects of air were evaluated by varying the springs during the ground test. The ground test employs a granite table with air bearing supports at the major hinge lines.

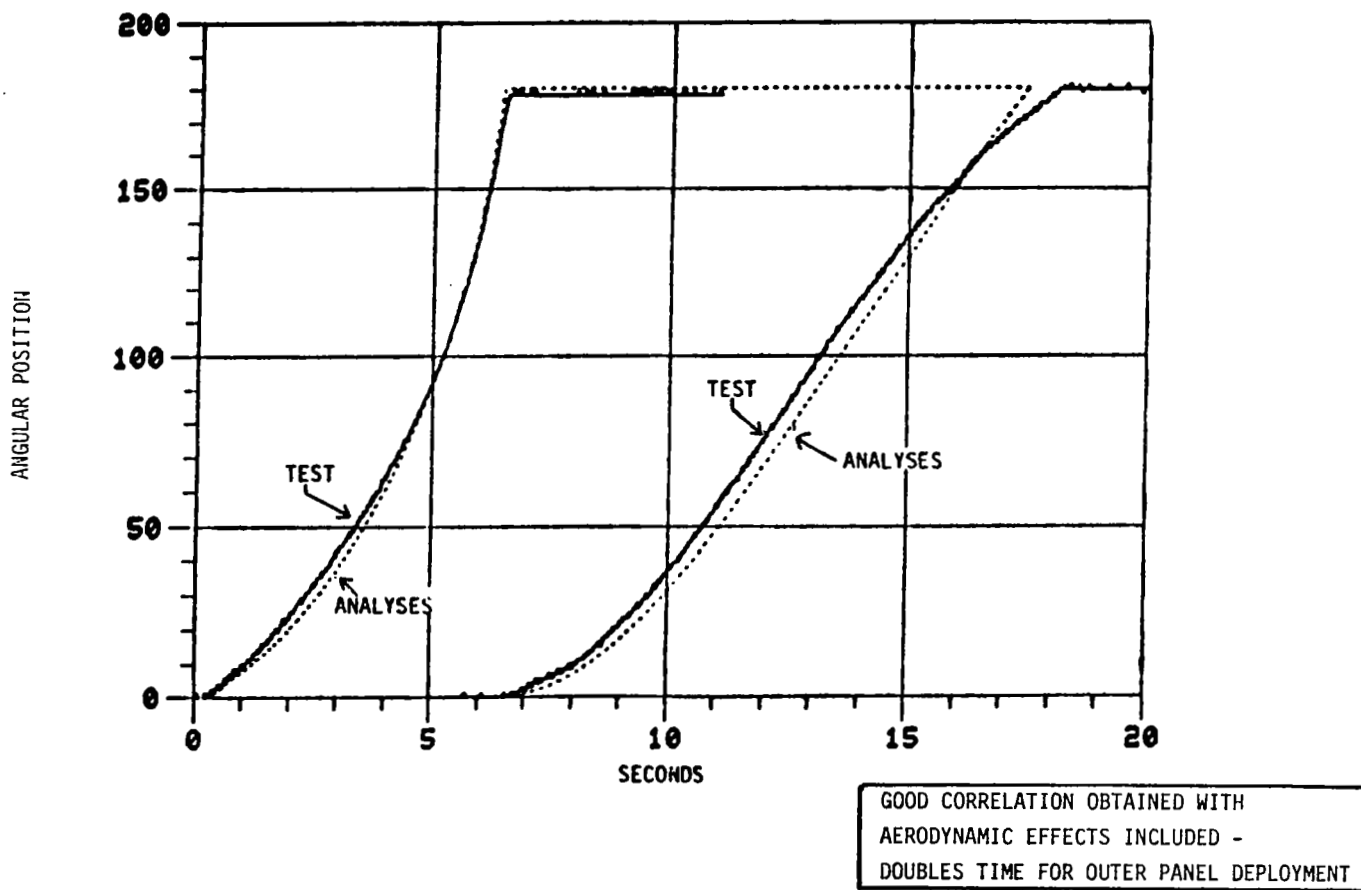

DEPLOYED SOLAR ARRAY GROUND TEST

The adequacy of the deployed solar array for flight was verified by static tests. The critical parameter of the deployed solar array is the resonant frequency which affects the interaction between the solar array and the attitude control system. However, the solar array cannot be deployed in a 1-g field without aids. Horizontal tests using suspension cables result in many extraneous modes and make interpretation of results difficult. For vertical deployment, there is a significant gravitational stiffening which would cause on the order of 20-percent increase in resonant frequency. A similar decrease in resonant frequency is caused by the virtual air mass. Because of these complications, a static test was performed, and the finite element model was matched to the test results. The array is slightly nonlinear as a result of load path changes through the latches.

COMPARISON OF ANALYSIS AND TEST RESULTS

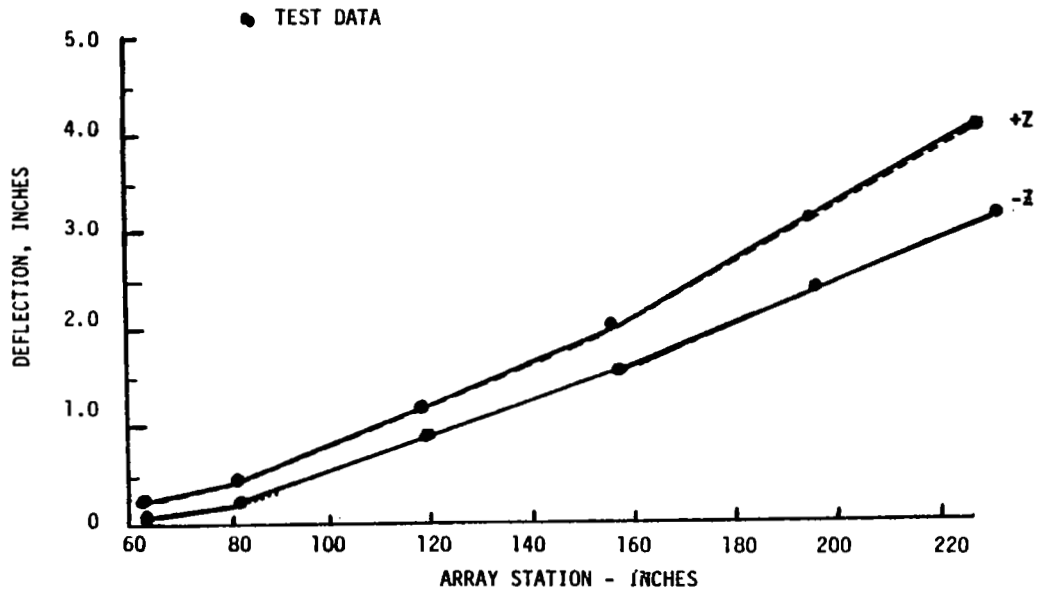

FEM ANALYSIS MATCHES TEST RESULTS
FOR SLIGHTLY NONLINEAR STRUCTURE

RELSAT DAMPING TECHNOLOGY DEMONSTRATION

GE-SSD is currently performing the RELSAT (Reliability for Satellite Equipment in Environmental Vibration) study for Dr. Lynn Rogers of the AF-Flight Dynamics Laboratory. This study will generically demonstrate passive damping control of panel-mounted component vibration using the DSCS III transponder panel. It is proposed that a second solar array panel be designed using the RELSAT technology to demonstrate the effectiveness of passive damping to reduce launch vibroacoustic and transient loading and to provide orbital damping. A stable space compatible viscoelastic epoxy material (SMRD 100F90), which has been used extensively to control vibration within electronic packages, is available for this application.

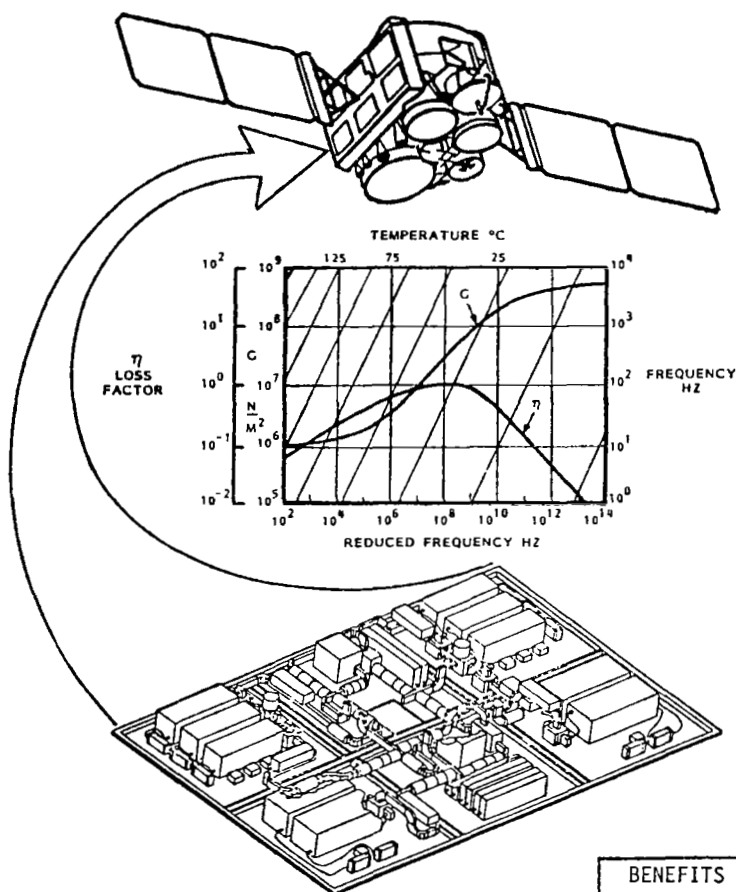

BENEFITS OF RELSAT DAMPING TECHNOLOGY
CAN BE EVALUATED FOR LAUNCH AND ORBIT

EXPERIMENT RESULTS

The proposed Articulated Panel Dynamics Experiment provides a cost effective approach to the evaluation of critical methodology that will drive the design of future large spacecraft structures. The accuracy of methods to combine transient and vibroacoustic loads will be assessed. It will evaluate the adequacy of current ground test methods and provide an assessment of key changes in the orbital behavior of low surface density structures due to gravity, aerodynamic, small amplitudes, and other factors. The role of passive damping in reducing launch stresses and alleviating structural interaction with control systems will be evaluated. By correlating analytical, ground test, and flight dynamic behavior, the groundwork will be established to confidently proceed with reliable light-weight designs that will achieve improved pointing accuracy for future large space structures.

- CRITICAL METHODOLOGY ESTABLISHED FOR THE DESIGN OF LOW SURFACE DENSITY PANEL STRUCTURES
 - TRANSIENT AND VIBROACOUSTIC LOADS
 - THERMAL STRESS OF MULTI PANEL STACK
- DEPLOYMENT PARAMETERS QUANTIFIED
 - AERODYNAMIC EFFECTS
 - OTHER GROUND/SPACE EFFECTS
- DEPLOYED SOLAR ARRAY ANALYSIS AND GROUND TESTS CORRELATED TO SPACE
 - ZERO G
 - AERODYNAMIC EFFECTS
 - SMALL AMPLITUDE CHARACTERISTICS
 - NONLINEARITIES
 - INHERENT DAMPING
 - ORBITAL DISTURBANCES
- PASSIVE DAMPING EVALUATED FOR LAUNCH AND ORBIT
 - REDUCED STRESS AND VIBRATION
 - CONTROLLABLE STRUCTURE

BENEFITS FOR FUTURE LARGE SPACE STRUCTURES

- LIGHTER WEIGHT DESIGNS
- ENHANCED RELIABILITY
- DESIGN CONFIDENCE
- IMPROVED POINTING ACCURACY

MATURE DESIGN SUPPORTED BY DETAILED ANALYSIS
AND EXTENSIVE GROUND TESTS PUTS THE EMPHASIS
ON SPACE VALIDATION OF PRESENT METHODOLOGY

STEP FLIGHT EXPERIMENTS
LARGE DEPLOYABLE REFLECTOR (LDR) TELESCOPE

F. C. Runge
McDonnell Douglas Astronautics Company
Huntington Beach, California

LARGE DEPLOYABLE REFLECTOR (LDR) TELESCOPE
(NASA/DOD)

STEP can provide a valuable flight test laboratory for developing the many technological advancements required for this 10- to 20-meter multi-mirror telescope. Subsystem parts, subassemblies, and whole assemblies must be flight tested in solo fashion as well as integrated with other eventually interfacing subsystems to develop basic design criteria and later to verify analytical models. Perhaps major portions of the LDR will have to be tested at subscale or full scale to give maximum assurance of operational deployability, rigidization, alignment, reliable, accurate performance, and serviceability.

This paper describes a variety of LDR experiments for performance on STEP as conceived by MDAC personnel including Les Westenberger (Structures), Richard Trudell/Jim Peebles (Structural Dynamics), Gene Burns (Mechanisms and Berthing), Fred Shepphird (Optics), Bill Nelson (Thermal Control), and George King (Deployment).

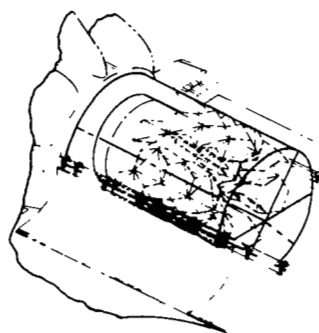

**Protected in
Cargo Bay
By Enclosure**



**Partially
Deployed**

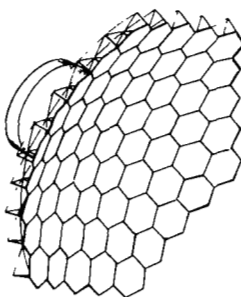

**Fully Deployed
Primary Mirror**

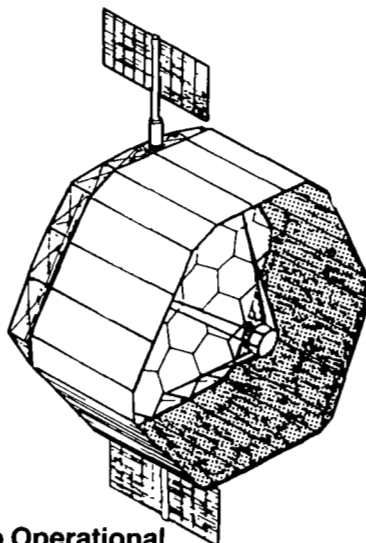

**All-Up Operational
Spacecraft**

- 10-Meter Diameter
- Sixty 1.2-Meter Hex Mirrors
- Secondary Mirror/Struts
- Sun Shade (Radiator)
- Spacecraft

LDR EXPERIMENTS ON STEP OVERVIEW

OBJECTIVES

Progressively Verify Performance of LDR Design/Models Structures, Mechanisms, Controls and Optics

STEP FLIGHT PLAN (3-Year Program)

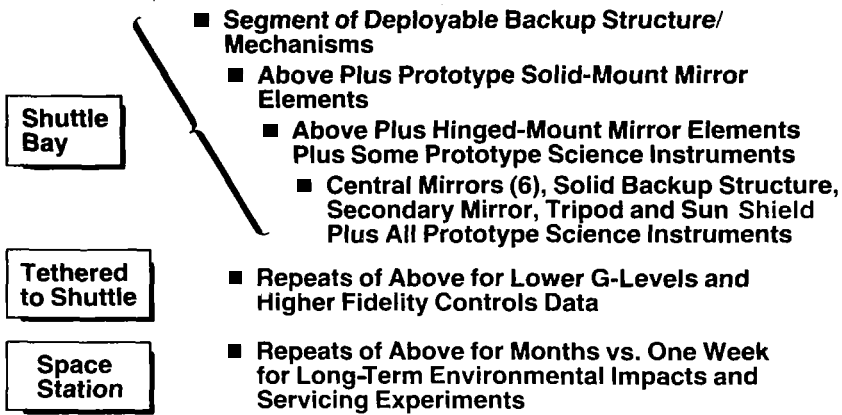

LARGE DIAMETER INFRARED TELESCOPE (NASA/DOD)

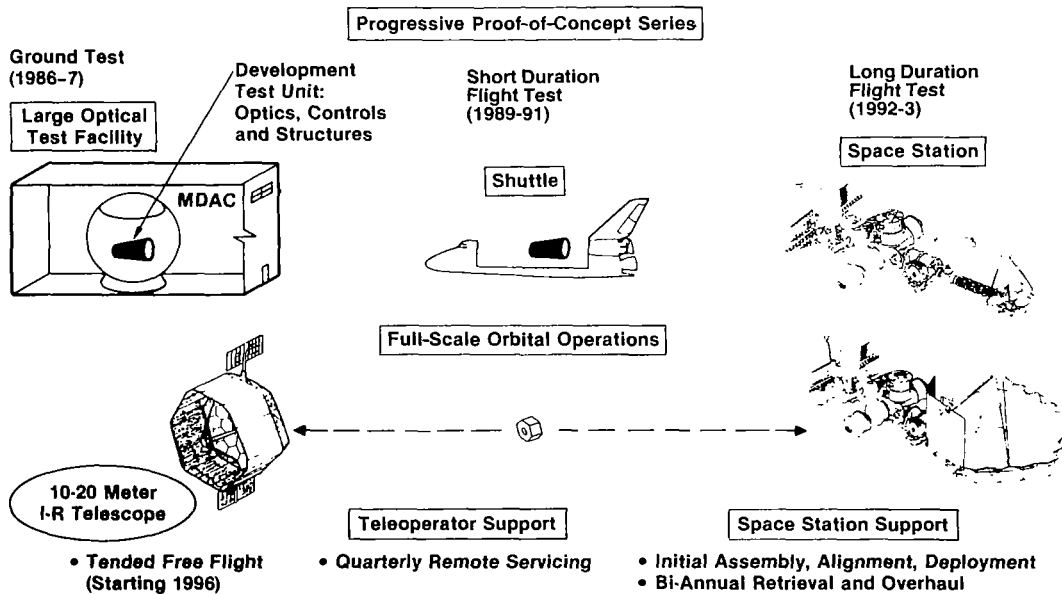

STEP FLIGHT MODES

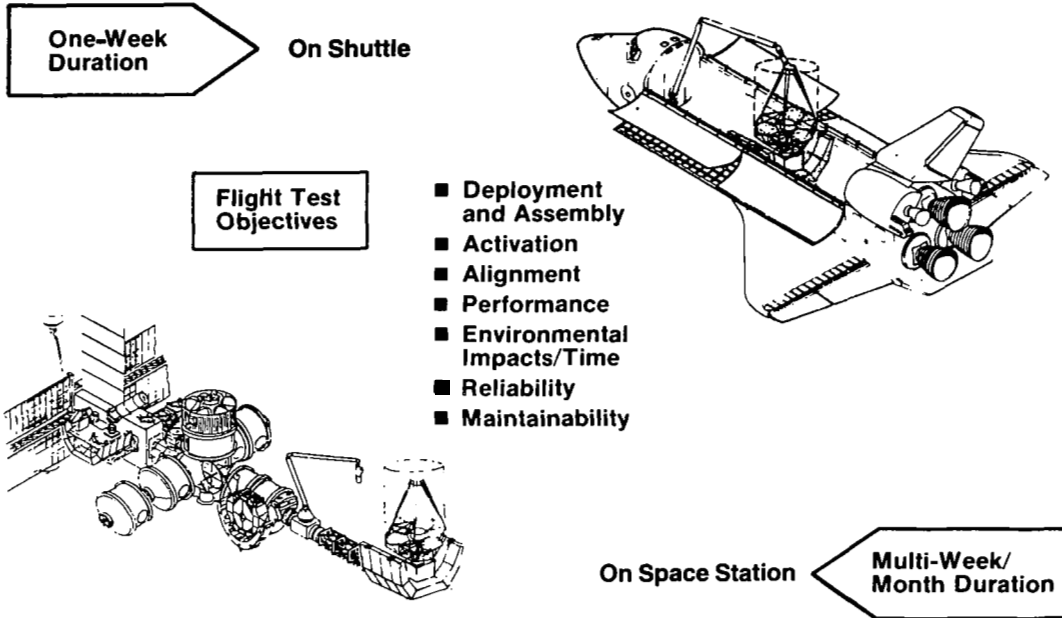

LDR TECHNOLOGY EXPERIMENTS ON STEP (PHASING OF OBJECTIVES)

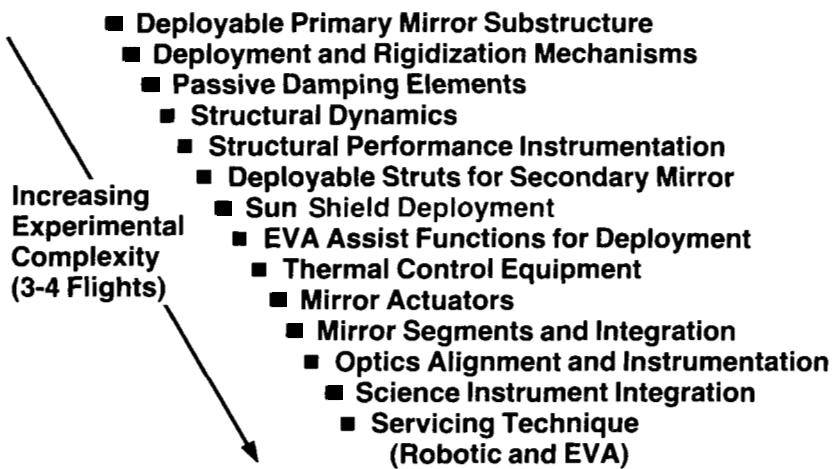

POTENTIAL LDR EXPERIMENTAL PROGRESSION (GROUND LAB/FLIGHT STEP)

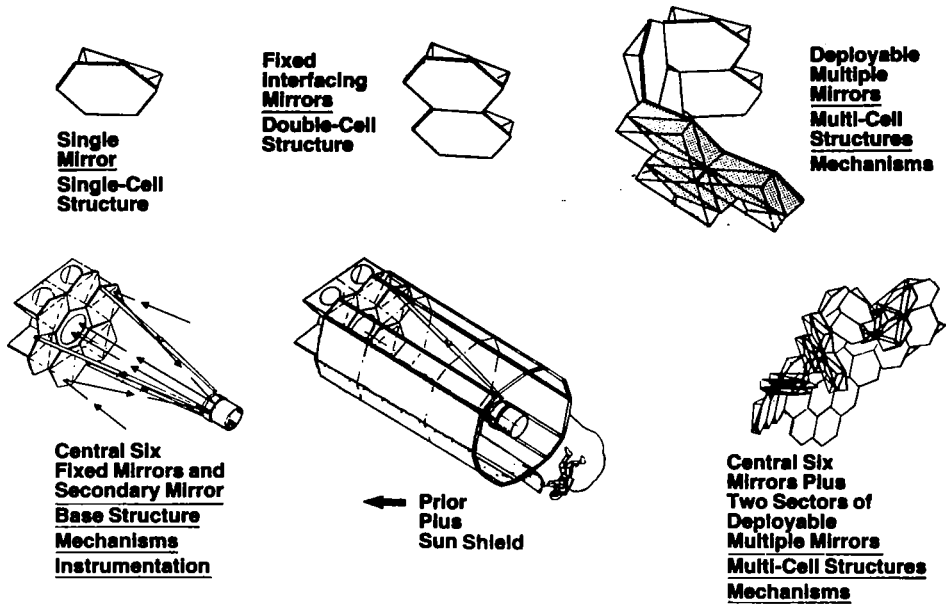

LDR TECHNOLOGY EXPERIMENTS DETAILED OBJECTIVES

- | | |
|------------|--|
| Objectives | <ul style="list-style-type: none"> ■ Utilizing the Space Technology Experiment Platform (Step),
(First on Shuttle, Later on Space Station) ■ Evaluate Performance of <ul style="list-style-type: none"> ● Deployment Modes <ul style="list-style-type: none"> — Reliability — Positioning Accuracy — Automatic, EVA, Hybrid ● Deployment Mechanisms <ul style="list-style-type: none"> — Activation — Action — End State (Achievement/Sustenance) — Serviceability ● Mirror Backup Structure <ul style="list-style-type: none"> — Dynamics — Change of State/Environment — Damping Alternatives — Verify Analytical Models ● Mirror Actuators <ul style="list-style-type: none"> — Response vs Input — Interaction — Environmental Impact — Serviceability ● Mirror Segment Performance <ul style="list-style-type: none"> — Deformation — Surfaces/Edges ● Mirror/Structural/
Mechanical System ● Sun Shield <ul style="list-style-type: none"> — Erectability — Shading/Pointing — Thermal Control ● Instrumentation <ul style="list-style-type: none"> — Mechanism — Structure — Mirror — Thermal |
|------------|--|
- Collect Data on Elemental and Collective Contributions to Performance

LDR DYNAMICS AND CONTROL ISSUES RESOLUTION

The chart below lists six hypothetical critical issues that are typical of classes of issues likely to arise during the course of the control system development. The chart also lists four approaches to the validation process ranging from computer analysis and ground tests to flight test experiments and all-up system level checkout and tests during operational missions. Four of the issues are seen to involve STEP-class experiments performed in the Shuttle payload bay. One issue, disturbance isolation, is shown to require only computer analysis for its resolution prior to an operational mission; another issue, secondary chopping disturbance, most likely could be resolved during ground tests. The other four issues will require spaceflight for their resolution.

<u>Critical Issues</u>	Validation Approach			
	Computer Analysis	Ground Test	Shuttle Flight Test	Mission Operation
Segment Optical Figure Stability/Quality Deployed			X	
Structure Dynamics and Nonlinearities			(X)	X
Segment Alignment Control Performance	[X]		(X)	X
Secondary Alignment Control Performance	[X]		(X)	X
Disturbance Isolation	[X]			X
Secondary Chopping Disturbances		X		

- () All-Up, System Level Test Impractical
- [] Primary Preoperational Validation

LDR FUNCTIONAL PERFORMANCE CHARACTERIZATION

Four of the STEP-class experiments identified on the prior chart are visualized in this companion diagram. In each case, the experiments would not demand a dedicated mission for their execution. While the diagrams do identify the articles of the LDR to be tested as well as the required instrumentation, they are merely representations of schemes to validate and to characterize the functional performance of elements of the LDR. The instrumentation detailed in this figure is typical of a wide range of optical test options. The upper two experiments involve basic tests of the primary mirror backup structure and the mirror segments' individual optical properties when exposed to the space environment. These concepts would rely on self-contained sources of radiation to make the required measurements.

The lower two experiments illustrated involve dynamic tests of mirrors and alignment controls with instrumentation that utilizes natural sources of radiation (stars or other science objects) to perform the observations.

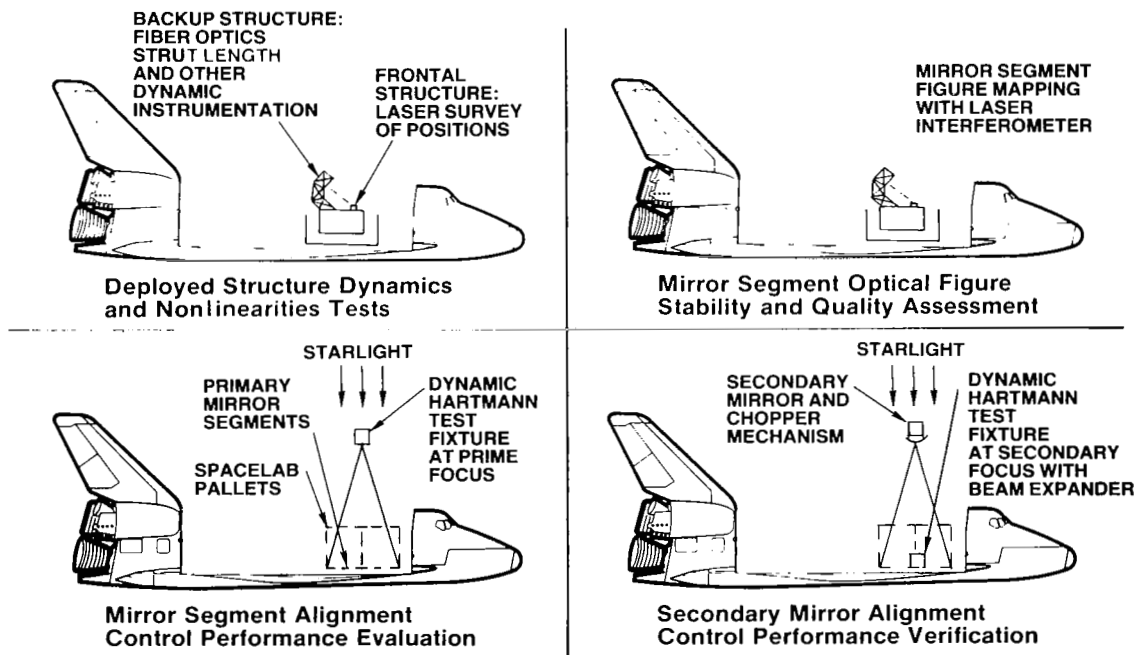

PHASE I – LDR/STEP TESTING

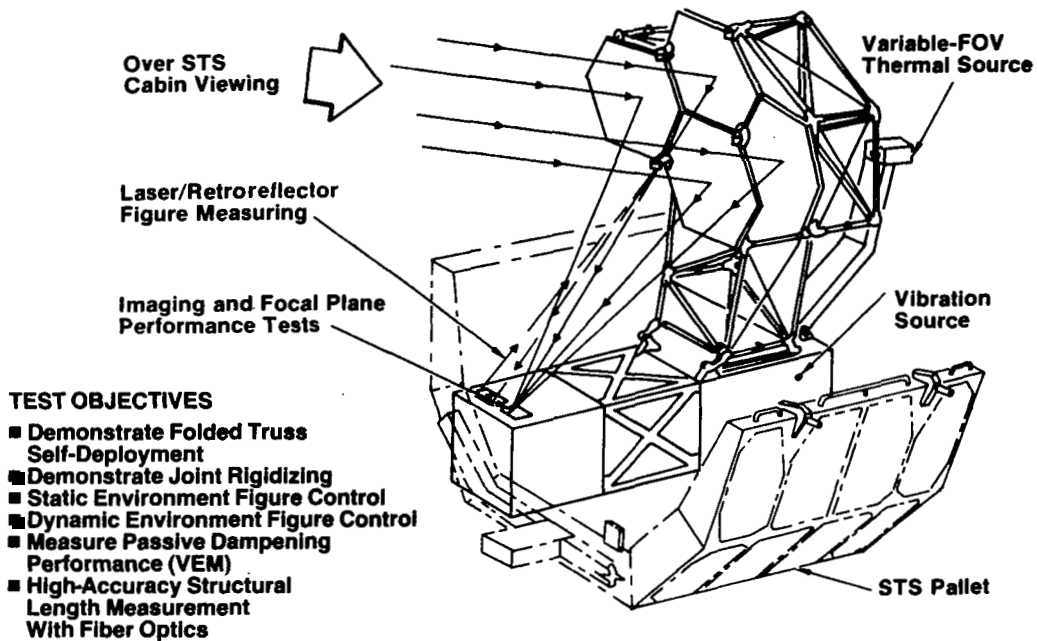

LDR DEPLOYMENT MECHANISM EXPERIMENT

Objective : Test and Evaluate Mechanism Performance

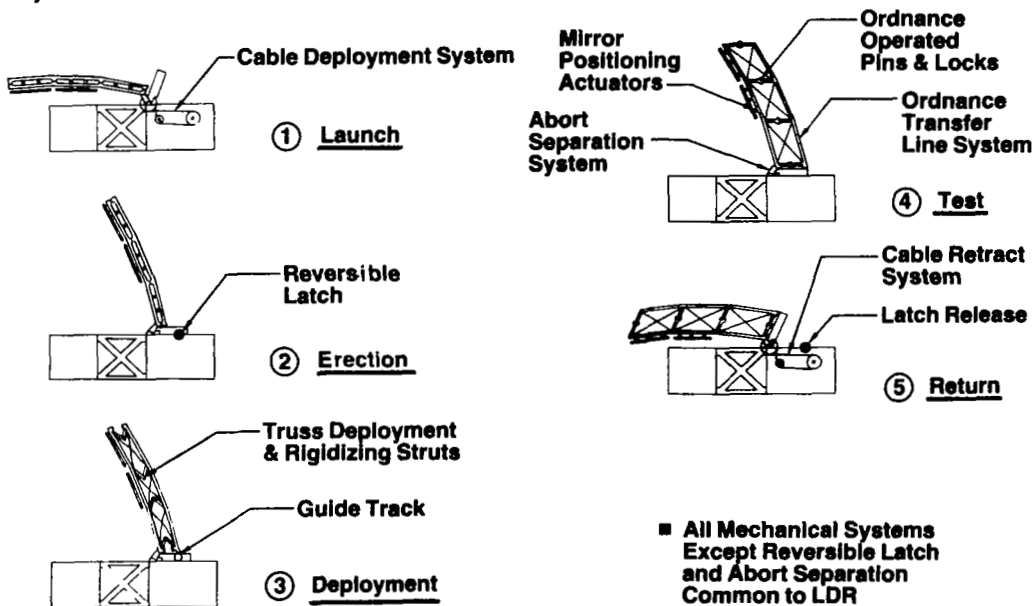

LDR MECHANICAL ISSUES

- **Nonreversible Truss Deployment**
- **Extensive Use of Electro-Explosive Devices for Rigidizing Structure**
- **Returned in Different Configuration Than Launch**
- **Malfunction Abort Requirements**
- **Full Scale or Subscale**
- **Mirror Positioning Actuators Resolution, Life, Reliability**

TRUSS DEPLOYMENT AND RIGIDIZING STRUT

This concept sketch illustrates a folded strut that is spring loaded (using a torsion spring) to deploy it to the extended position. Since the mass of the truss being deployed by many of these struts is large, end-stroke damping is required to prevent structural damage. A confined crushable is utilized to provide a resisting torque near the end of the deployment stroke. After deployment, the strut is rigidified by actuating an electroexplosive device (EED) which drives a tapered pin through the two halves of the strut on the centerline of the strut.

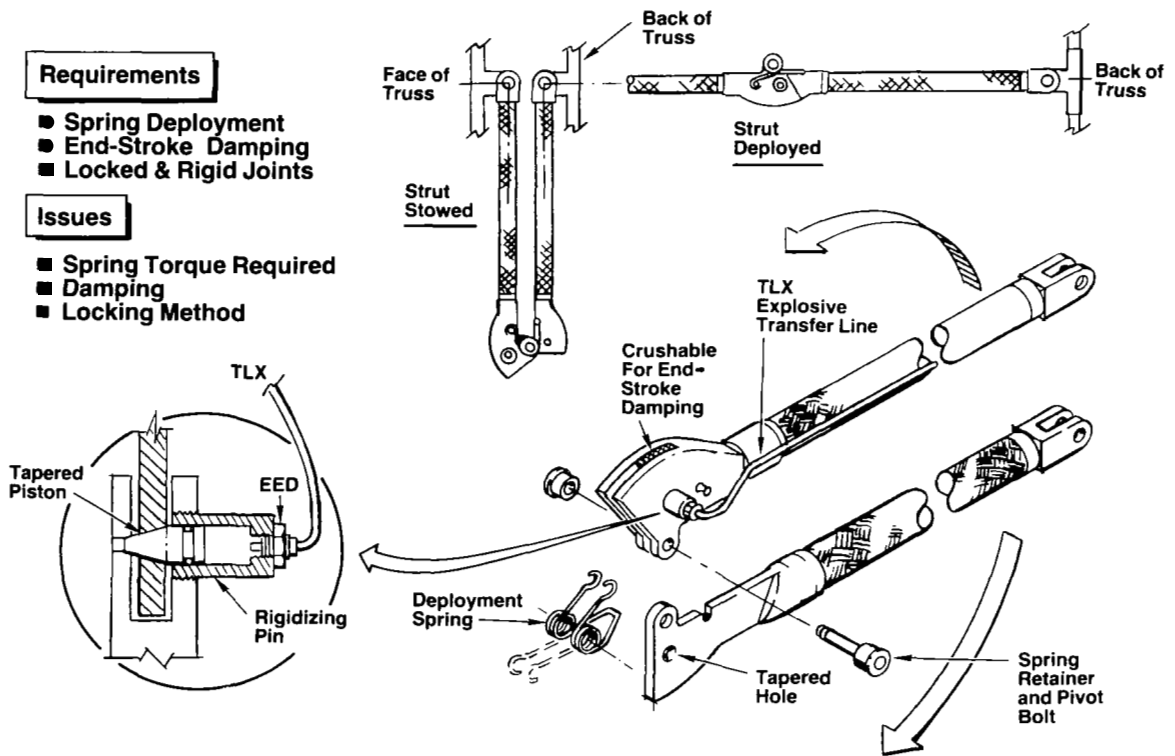

MIRROR ACTUATOR TESTING AND REPLACEMENT

Objective:

- To Evaluate Crew Removal and Replacement of Mirror Positioning Actuators, Using Common and Special Tools & Handling Equipment

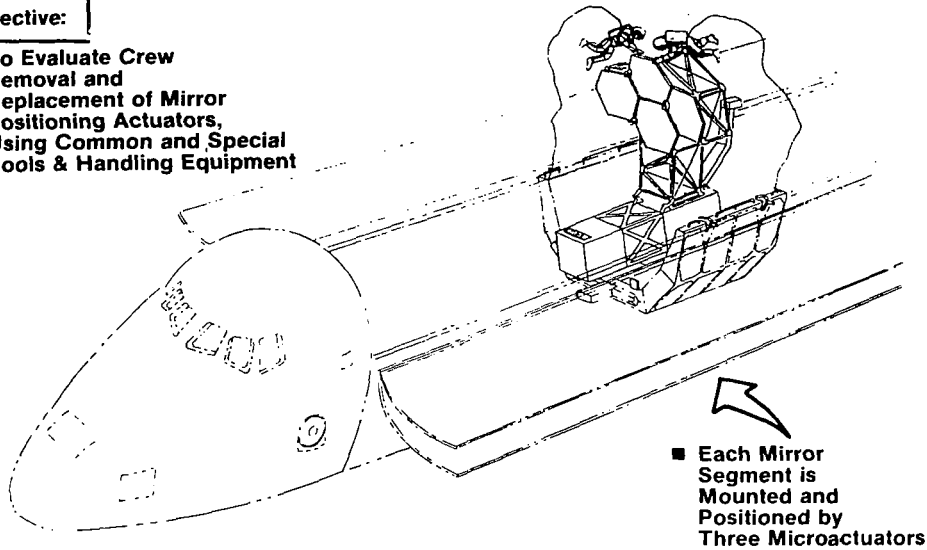

EVA SERVICING ON LDR MIRROR ACTUATORS (STEP EXPERIMENT)

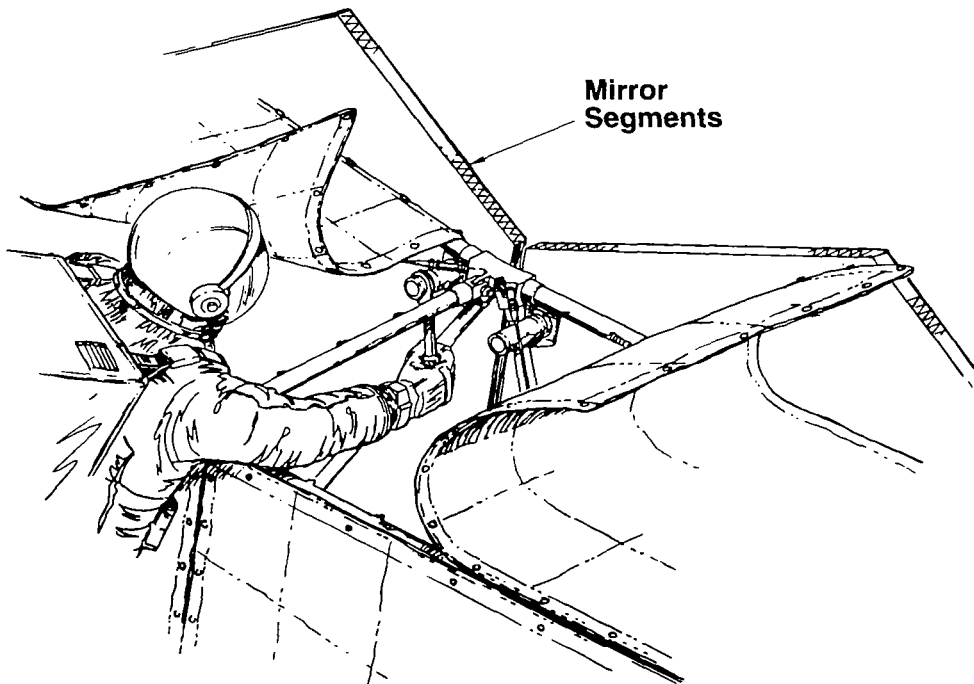

STRUT/JOINT TESTING AND CHANGEOUT

Objective:

- Evaluate Passive Dampening Performance of Various Structural Elements Incorporating Different Viscoelastic Materials (VEM's) and Joint Concepts
- Crewman Removes Each Structural Element & Replaces With Strut Incorporating VEM (Test Article Designed for Easy Replacement of Elements)

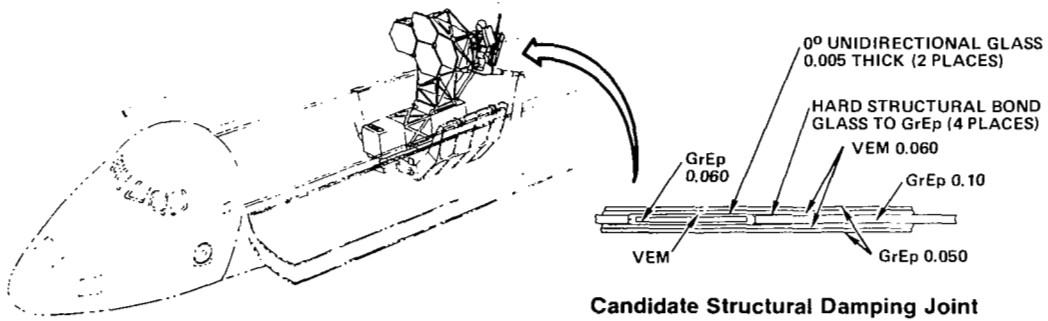

LDR MIRROR POSITIONING ACTUATOR

Requirements

- Stroke 10-50 mm
- Load Capacity 1-200 kg
- Resolution 0.5 μm min

Issues

- Resolution
- Orbit Replacement

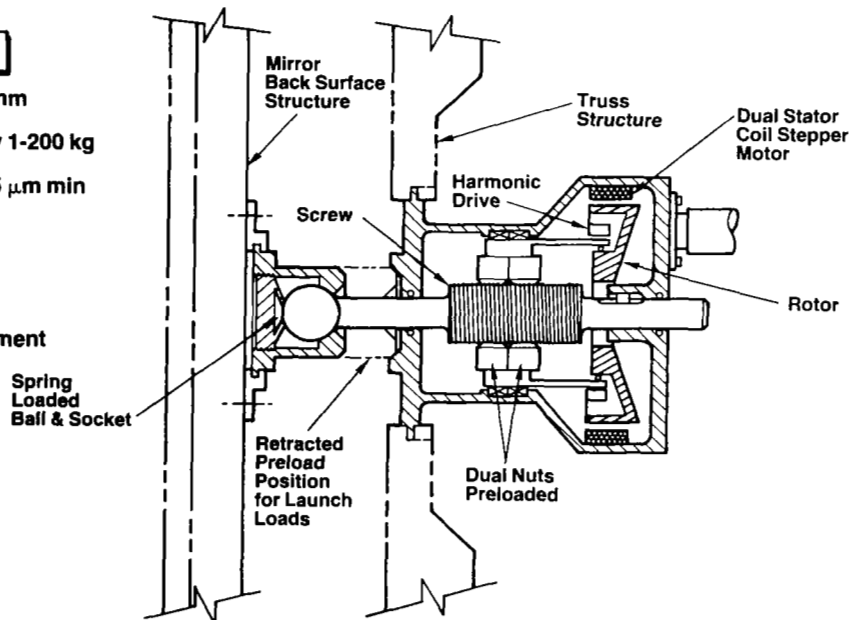

EVA TECHNIQUE DEVELOPMENT

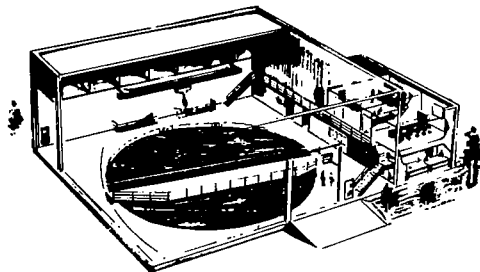

MDAC Underwater Test Facility

Sun Shield
Installation

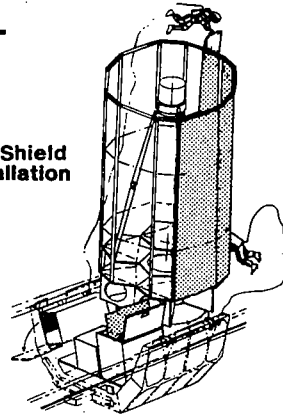

Structural
Experiment
Element
Replacement

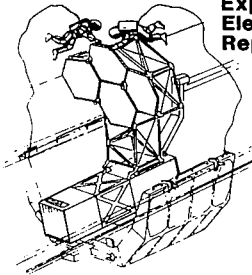

Mechanism
Replacement

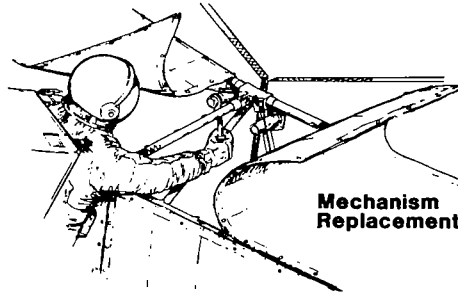

WHAT'S HAPPENING IN THIS JOINT?

Issues

- Modelling Uncertainties
- Structural Linearity
- Dimensional Stability
- Low Amplitude Damping

Sources of Trouble

- Fabrication Tolerances
- Assembly Variations
- Built-In Stresses
- Repeat-Actuation Stress Redistribution
- Material Response to Environment

Analytical Challenge

- Accurately Model Joints to Qualify System Characterization

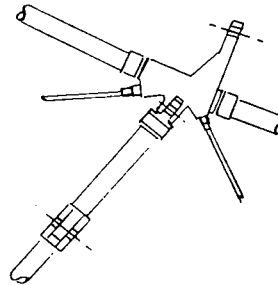

Design Challenge

- Accumulate Enough Knowledge to Design Linearized Joints or Well Understand Nonlinear Joints

Test Challenge

- Provide Data on Generic and System-Applied Joints to Support Analysis and Design

PRECISION LINEAR RESPONSE STRUCTURAL JOINTS

Test Objectives

- Demonstrate Precision Linear Joint Concepts
- Validate Joint/Latch Designs and Fabrication Methods
- Validate Modal Performance Analysis Tools

Description

- Erectable/Deployable Truss Elements
 - 'Free-Flyers' With Data Transfer Umbilical

Measurements

- Strain and Acceleration Time Histories

Results

- Provides Empirical Data Base for
 - Structural Evaluation of Erectable Versus Deployable Truss
 - Joint/Latch Performance (Precision, Reliability, Strength)
 - Evaluating Adequacy of Linear Superposition Analysis Tools

PROLOGUE "GENERIC" STRUCTURAL DYNAMICS TEST — I

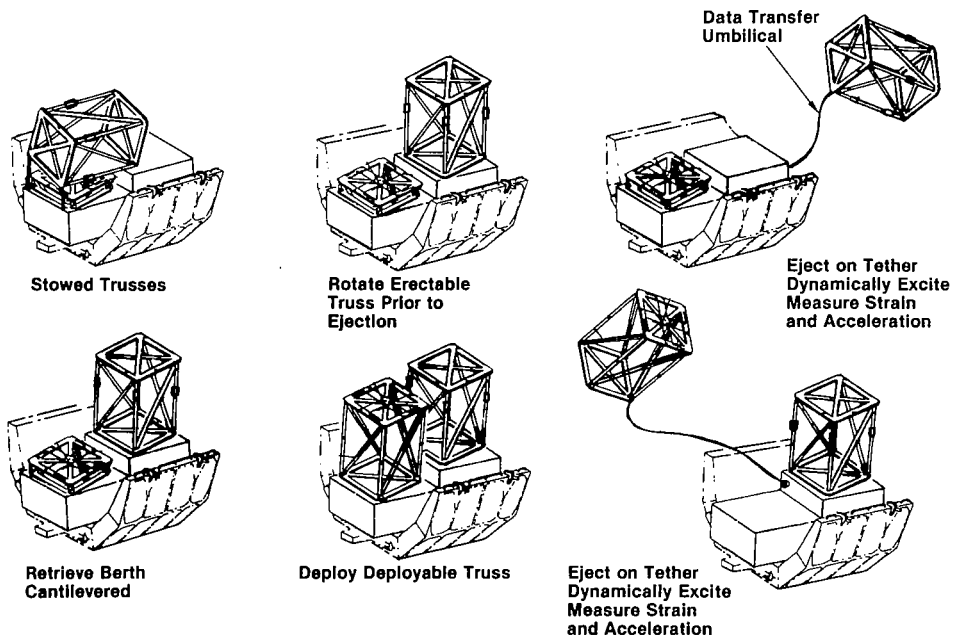

STABILITY OF VISCOELASTIC JOINTS

Test Objective

- Determine Dimensional Stability of Truss With VEM Joints

Description

- Erectable Truss Element
 - Cantilevered
 - VEM Joints Released via EVA

Measurements

- Strain and Displacement Time Histories at Various Temperatures

Results

- Provides Empirical Data Base for Evaluating Applicability of VEM for Precision Pointing Structures

PROLOGUE "GENERIC" STRUCTURAL DYNAMICS TEST

(SECOND PHASE)

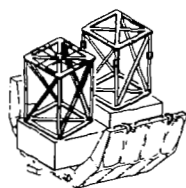

Retrieve Berth
Cantilevered
Dynamically Excite
Measure Strain and
Displacement

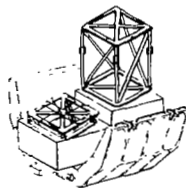

Stow Deployable

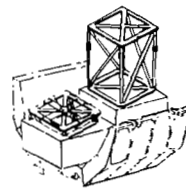

Dynamically Excite Erectable
Measure Strain and Displacement
(Check Initial Dimensional Alignment)

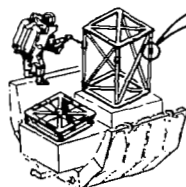

EVA Release VEM Joints

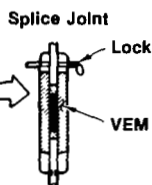

Lock
VEM

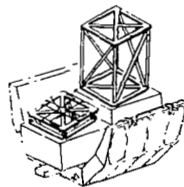

Dynamically Excite
Measure Strain and Displacement
Versus Time and Temperature

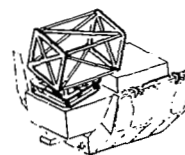

Stow Erectable

“LDR-APPLIED” STRUCTURAL DYNAMICS TEST

LDR Mirror Segments With LDR-Type Backup Truss Modules

- **Deploy Truss (Cantilevered)**
 - Dynamically Excite
 - Take Measurements Versus Time

- **Rigidize Joints (EVA Lockup)**
 - Excite
 - Take Measurements Versus Time

- **Release VEM Joints (Back Face Struts)**
 - Check Dimensional Alignment
 - Excite
 - Take Measurements Versus Time and Temperature

Compare
Data With
Prologue
Test

SENSING MICRO/MACRO STRUCTURAL DYNAMICS WITH FIBER-OPTICS AND LASERS

Micro-Measurement

- **Fiber Optics Interferometry**
 - Fiber-Wrap Sensors On Several Hundred Struts
 - Determining Extent and Frequency of Strut Length Changes to $.001\mu\text{m}$ at Rates Up To 2 MHz
 - In Modular Sets of 40 Sensors/ Laser (5-6 Sets)
 - Power: 50-75 Watts

Macro-Measurement

- **Laser Position Sensing**
 - Centralized Laser Coordinating Four Outboard Lasers Through Beam Splitter
 - Satellite Laser Beam Split For Scanning Retroreflectors at Major Joints
 - Power: 50-75 Watts

Micro/Macro Data Processing

- TBD Mbits and Power

Micro/Macro Sensing Output

- Data For Correlating Per Performance of Mirror Segments, Segment Actuators and Backup Structure

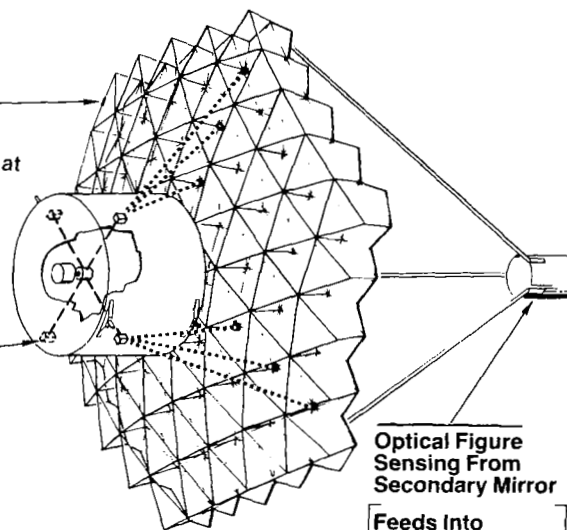

Optical Figure
Sensing From
Secondary Mirror

Feeds Into
Processor
Which Drives
3 Actuators
Underneath Each
1 Meter Hex
Mirror Segment

SOLID-STATE FIBER OPTIC LENGTH SENSOR

Approach:

- Measure Spectral Coherence Components
- Solid-State Superradiant Diode
- Single-Mode Fiber Reference Length
- All Fiber Couplers and Combiners
- Small, Low Power, Nonmechanical

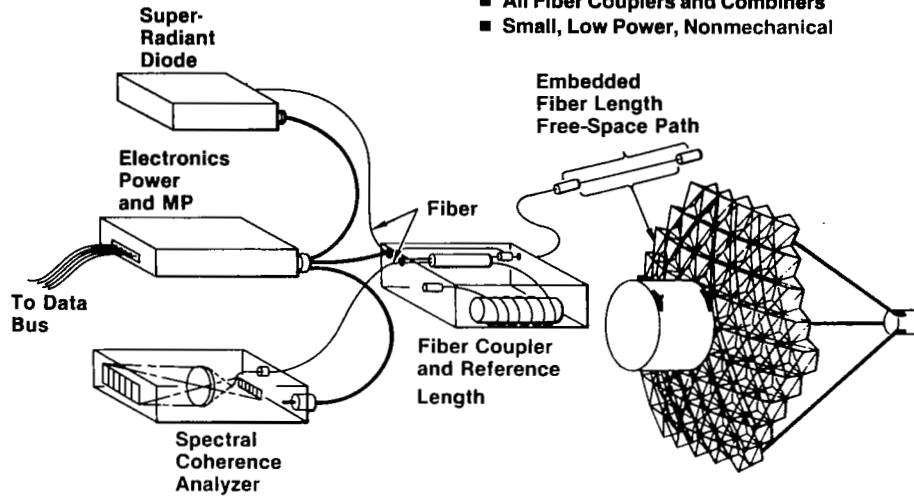

PRIMARY/SECONDARY MIRROR DEPLOYMENT/DYNAMICS TEST (PHASE II)

Test Objectives

- Secondary Mirror Deployment & Position Control Relative to Primary
- Strut Rigidization and Dynamics
- Verify Analytical Models
- Stowage, Dynamics and Impact of STS Ascent Environment

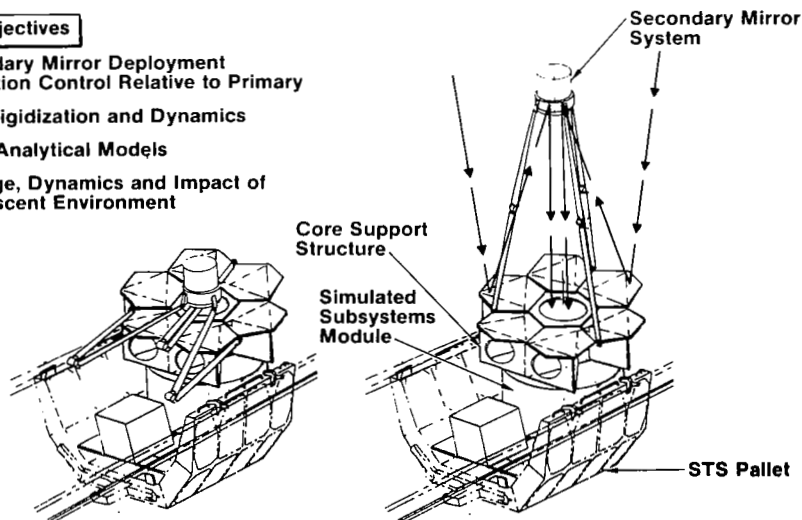

NEAR-FREE-FLIGHT DYNAMICS TEST (TETHERED CONCEPT) (PHASE IV)

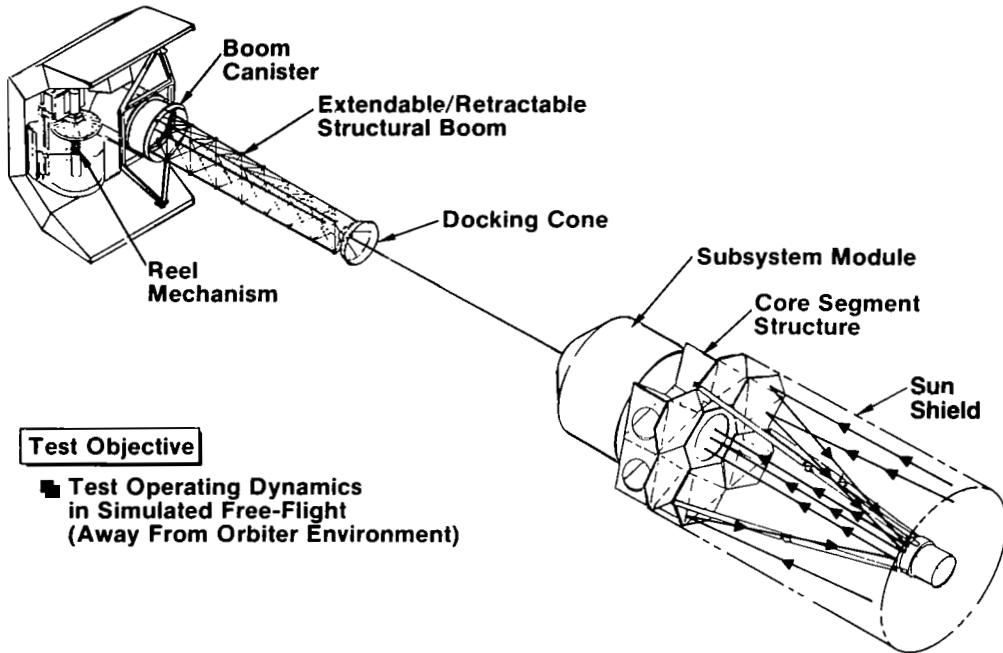

Test Objective

- Test Operating Dynamics in Simulated Free-Flight (Away From Orbiter Environment)

KEY ISSUES LDR THERMAL CONTROL

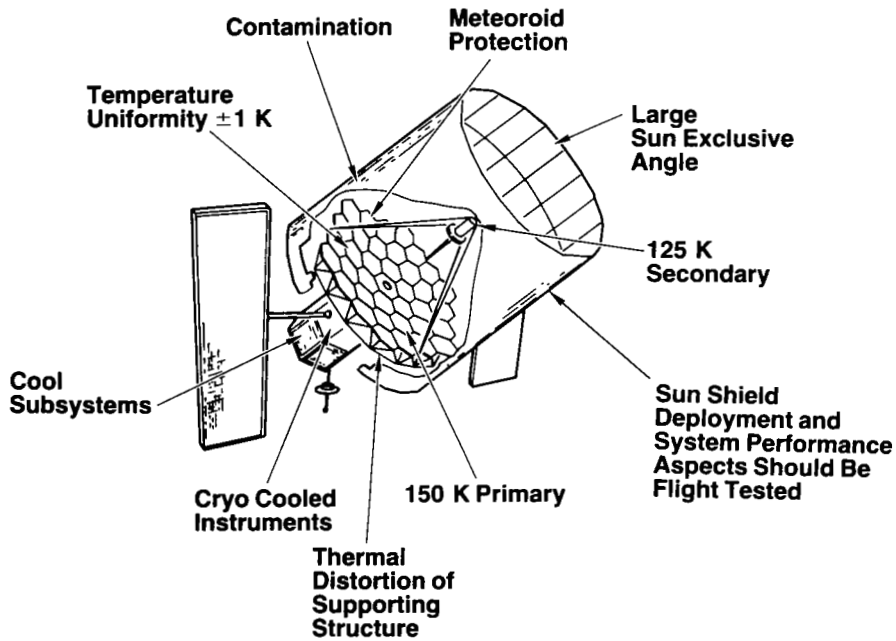

SUN SHIELD (AND RADIATOR) PERFORMANCE TEST (PHASE III)

Objectives

- Test Crew Ability to Assemble Sun Shield
- Provide Proper Thermal Control for Mirror Alignment Tests
- Space Verify:
 - Performance (Verify Models)
 - Deployment Concept
- Data to Optimize Flight System Design
- Concept Comparison Data
- Reduce Ground Test and Analysis

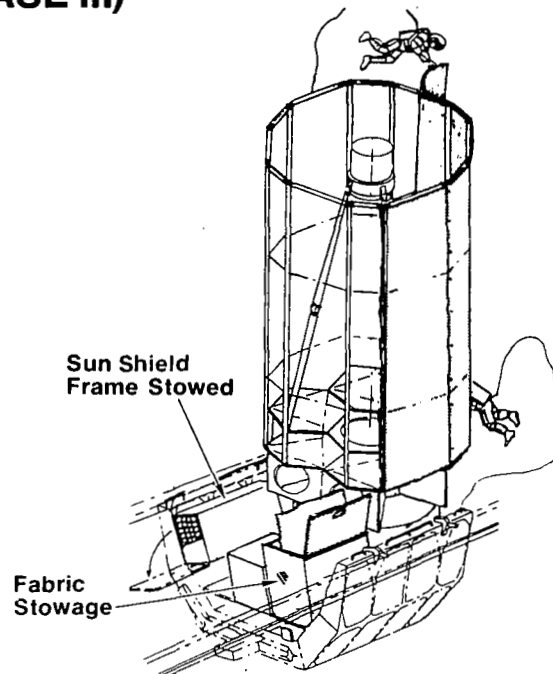

SUN SHIELD THERMAL CONTROL INVESTIGATIONS

- MLI Heat Leak
- Heat Leak to Mirror From Subsystems
- Performance of Active Thermal Control System
- Radiation Exchange Between Sun Shield and Mirror
- Thermal Distortion of Supporting Structure
- Radiation Dissipation by Baffles
- Mirror Temperature Gradients

SUN SHIELD/SHROUD COMBINATION

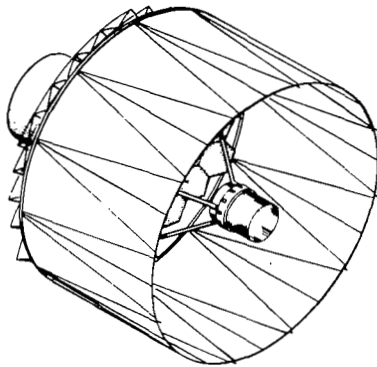

Functions

- Reduces Interference From Stray Light and Earth/Sun Thermals
- Prevents Contamination From Shuttle Propulsion and Cargo Bay During Servicing Revisits
- Reduce Impact of Meteoroid Showers

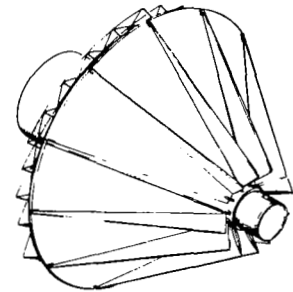
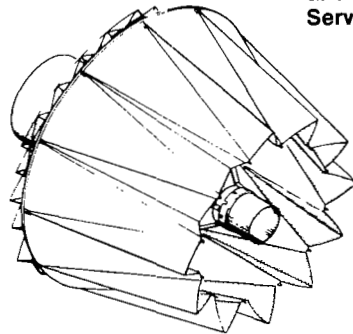

**Structural/Mechanical
Deployment and
Rigidization Performance
Should Be Flight Tested**

STEP TESTING - BERTHING/DOCKING

Half of the berthing/docking mechanism is attached to the rotation unit on the Spacelab pallet; the other half is attached to a simulated spacecraft. The simulated spacecraft is shown in the form of a split telescoping tank that could simulate mass and variation in center gravity.

In orbit, the experiment would be erected to protrude from the cargo bay and the berthing/docking mechanism would be extended. The simulated spacecraft is grappled by the RMS, then released and reberthed. Pressure bottles in the simulated spacecraft may be used to pressurize the berthing interface simulating the mating of two pressurized modules.

A "holster" containing an adaptive end effector (AEE) is mounted to one side of the pallet. This AEE can be mated with the RMS standard end effector and provides a claw or vise-type gripping device with gripping force feedback to the operator. This type of end effector can attach to various structural shapes in the event the object does not have an RMS grapple fitting.

Full-scale working models of both a berthing mechanism and the AEE have been designed and built by MDAC for NASA.

Objectives

- **Demonstrate on-orbit of Berthing/Docking Mechanism**
- **Demonstrate Use of Adaptive End Effector (AEE) With RMS**
- **Demonstrate Use of AEE to Handle Objects by Attaching to Standard Structural Members**
- **Evaluate Berthing Dynamics, Crew Control, CG Impacts**
- **Evaluate CCTV Use for Remote Berthing**
- **Demonstrate Pressurized Berthing Interface**

STEP TESTING – BERTHING/DOCKING

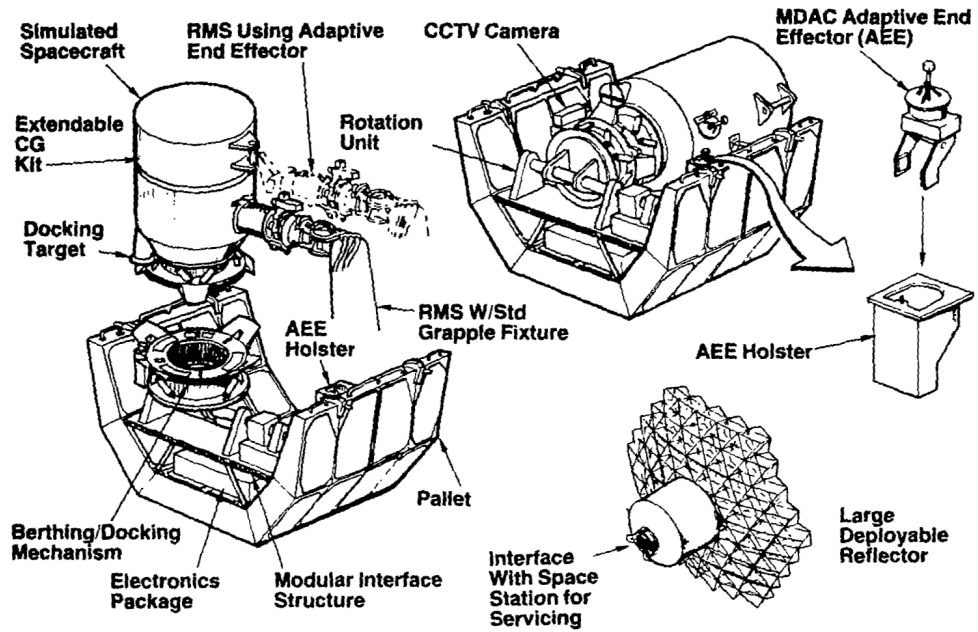

PROTOTYPE HARDWARE FOR GROUND TESTING

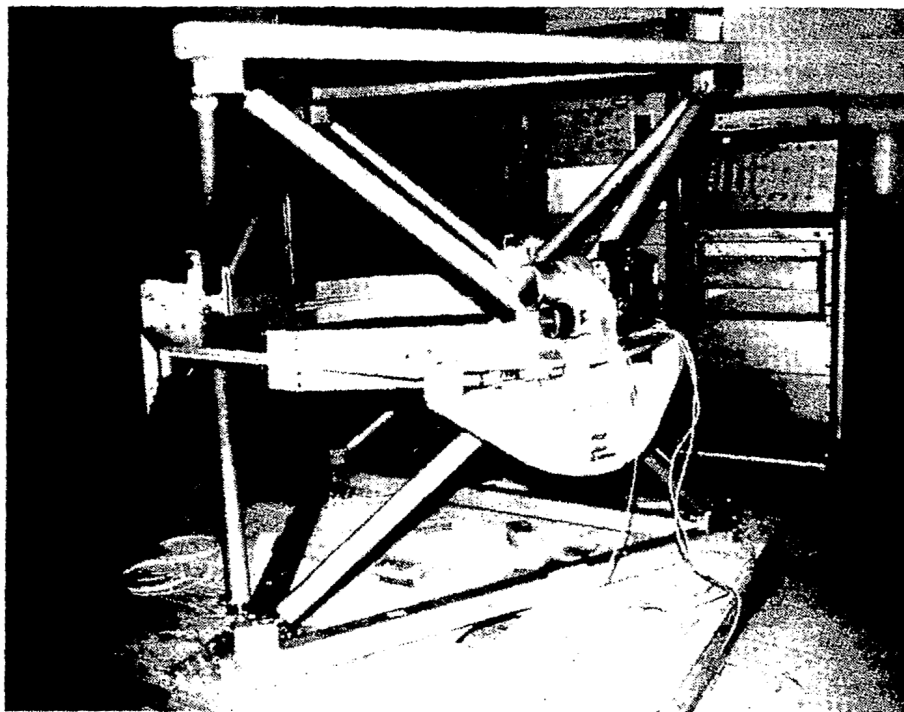

LARGE DEPLOYABLE ANTENNA FLIGHT EXPERIMENT
FOR THE SPACE TECHNOLOGY EXPERIMENTS PLATFORM (STEP)

B. C. Tankersly
Harris Corp.
Melbourne, FL

and

Thomas G. Campbell
NASA Langley Research Center
Hampton, VA

LARGE SPACE ANTENNA TECHNOLOGY

SPACE TECHNOLOGY

EXPERIMENTS

(WBS-51)

100 M/100 BEAM APPLICATIONS

- GEO COMMUNICATIONS
- LEO REMOTE SENSING
- SPACE STATION

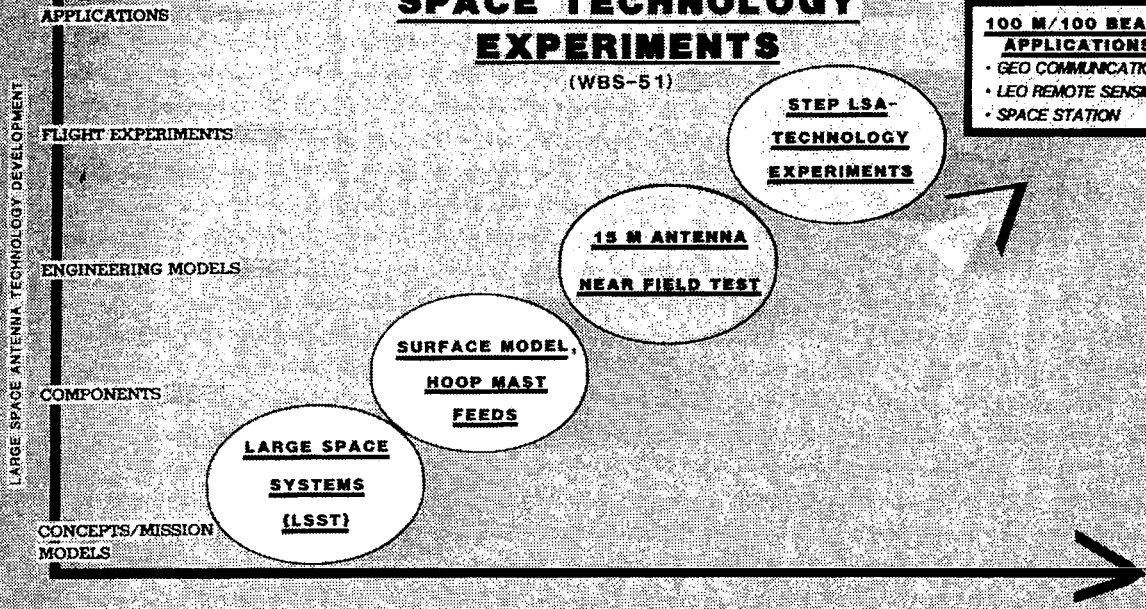

LARGE SPACE ANTENNAS

ELECTROMAGNETICS

- CONFIGURATION
- RF CHARACTERIZATION
- KEY TECHNOLOGIES



(DUAL APERTURE REFLECTOR SYSTEM)

RADIO FREQUENCY VERIFICATION ANTENNA MODEL

ANTENNA SURFACE MODEL

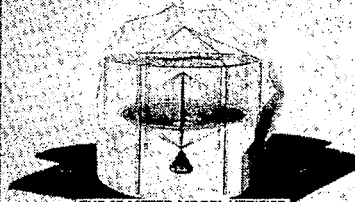

THE 15 METER MODEL VERIFIES

- DEPLOYMENT RELIABILITY
- ANALYTICAL MODELS
- MANUFACTURING TECHNOLOGIES
- CONTOUR INTERACTION EFFECTS

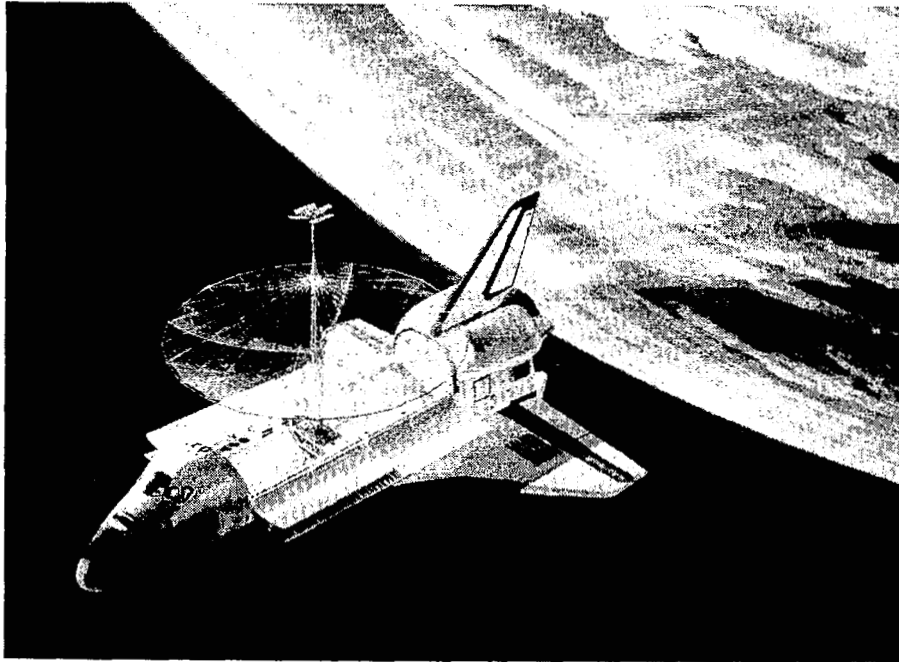

LARGE DEPLOYABLE ANTENNA FLIGHT EXPERIMENT

OBJECTIVES :

- 1. LARGE SPACE ANTENNA STRUCTURAL VALIDATION**
 - DEPLOYMENT & RETRACTION**
 - REFLECTOR SURFACE TOLERANCE**
 - THERMAL DISTORTION**
 - DYNAMIC/STRUCTURAL CHARACTERISTICS**
- 2. LARGE SPACE ANTENNA ELECTROMAGNETIC PERFORMANCE**
- 3. VERIFY ORBITAL PERFORMANCE OF MEASUREMENT SYSTEM(S)**
- 4. VERIFY TEST TECHNIQUES FOR ORBITER-ATTACHED LSS**
- 5. VERIFY SENSORS & ACTUATORS FOR LSS DYNAMIC CONTROLS**
- 6. VERIFICATION OF DYNAMICS & CONTROLS TECHNOLOGY FOR LSS**
- 7. ORBITAL VERIFICATION OF AN ADVANCED MISSION CONCEPT**

EXPERIMENT DEPLOYMENT SEQUENCE

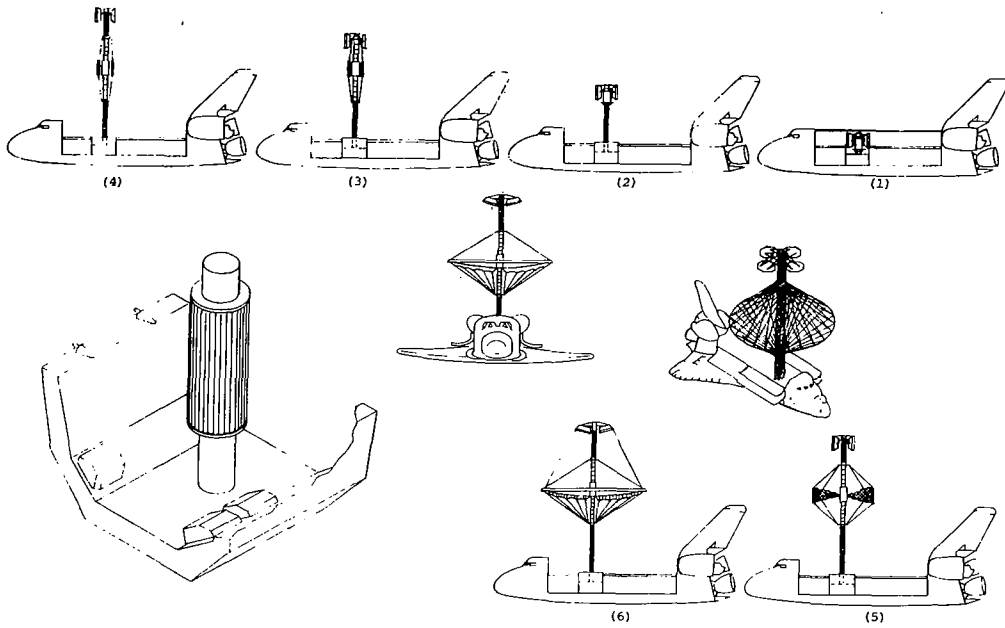

FLIGHT TEST PROGRAM

The flow chart below illustrates the test program for a 7 day mission. The test flow shown represents the general test approach. The exact test sequence will vary over the mission due to operational requirements of the orbiter and/or due to operational requirements for a given test. As an example, portions of the RF test would be conducted over several days in order to meet the operational requirements for this test.

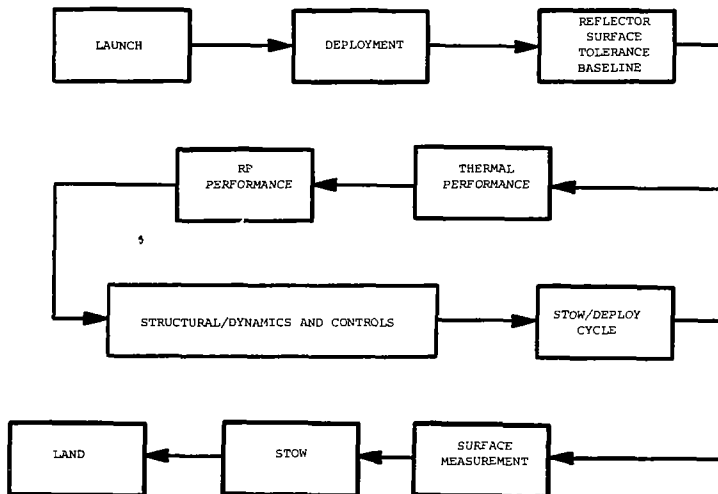

DEPLOYMENT TEST ISSUES

- Verification of deployment reliability.
- Verification of deployment repeatability.
- Verification of retraction and assessment of reflector surface (mesh) damage by retraction.
- Verification of deployment analytics and stability of the structure during deployment.

TECHNICAL CHARACTERISTICS AND GOALS	MISSION					
	OPTICS	LDR	SDR	LMSS	ADV COMM	15 METER EXP.
PARTS COUNT/HINGES-LATCHES	10 ⁴	10 ⁴	10 ³	10 ³	10 ³	10 ²
TIME TO DEPLOY (MIN)	10 ²	10 ² -10 ³	10-10 ²	10-10 ²	10-10 ²	10-10 ²
RETRACTION POTENTIAL	YES	YES	HIGH POTENTIAL FOR MESH DAMAGE MUST BE ASSESSED			YES-MESH DAMAGE CAN BE ASSESSED
DYNAMIC STABILITY	HIGH	HIGH	LOW	LOW	LOW	STABLE
LAB TESTABILITY	FULL SCALE	FULL SCALE	SCALED AND ANALYSIS			GROUND TEST CAPABILITY
REPEATABILITY	NOT CRIT	NOT CRIT	NOT CRIT	CRIT	NOT CRIT	CRITICAL
FORCES AND REACTIONS	LOW	LOW	HIGH	HIGH	HIGH	LOW
FAILURE RECOVERY	POSSIBLE	POSSIBLE	POSSIBLE/NO			POSSIBLE
ACTUATION	POWERED	POWERED	POWERED (SLOW) OR POTENTIAL ENERGY			POWERED/CONTROLLED

CONCLUSION: THE 15 METER ANTENNA IS ADEQUATELY REPRESENTATIVE OF PLANNED LSA MISSIONS TO SERVE AS A DEPLOYMENT TESTBED.

TECHNOLOGY ISSUE

TEST PLAN

- | | |
|---|--|
| <ul style="list-style-type: none">● DEPLOYMENT RELIABILITY AND REPEATABILITY
● RETRACTION CAPABILITY
● DAMAGE OF MESH
● DEPLOYMENT ANALYTICS AND DYNAMIC STABILITY | <ul style="list-style-type: none">● MULTIPLE DEPLOYMENTS<ul style="list-style-type: none">- MONITORED BY CCTV- STRUCTURE AND SURFACE REPEATABILITY MEASURED
● MULTIPLE RETRACTIONS<ul style="list-style-type: none">- MONITORED BY CCTV- RESTRAINT SYSTEM RELATCH ON FINAL RETRACTION - MANUAL BACKUP PROVIDED
● MESH DAMAGE ASSESSED BY CCTV FOR EACH RETRACTION/DEPLOYMENT CYCLE
● CORRELATION OF ANALYSES WITH ORBITAL TEST RESULTS AND CORRELATION OF SIMULATED "0-g" GROUND TEST RESULTS WITH ORBITAL TEST |
|---|--|

REFLECTOR SURFACE TOLERANCE TEST

Objectives of the test include:

- Repeatability of the surface tolerance with multiple deployment/retraction cycles.

- Evaluation of the reflector surface tolerance variation under various environmental conditions.

- Verification of the analytics for prediction of surface tolerance.

- Evaluation and verification of technique(s) for orbital measurement of a large reflector surface.

THERMAL ENVIRONMENTS WHICH BOUND THE ANTENNA PERFORMANCE ARE SELECTED FOR TEST

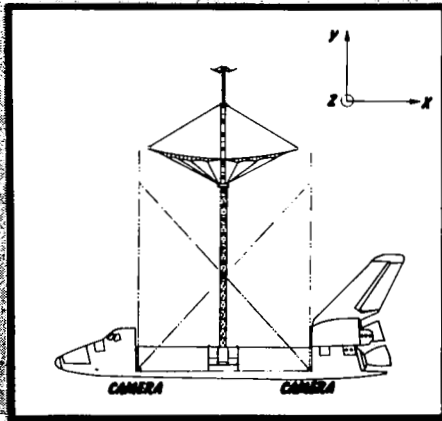
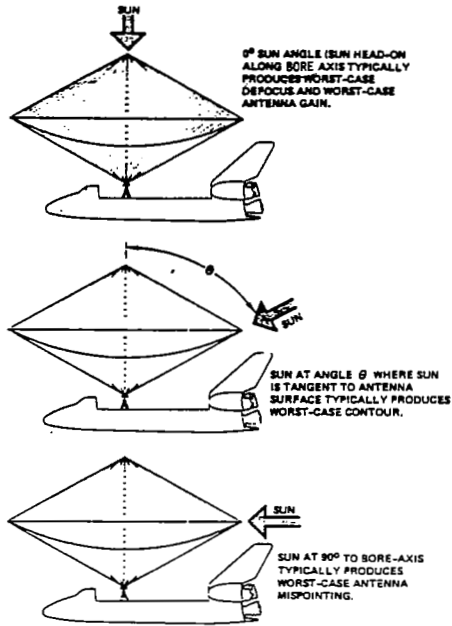

15-METER DEPLOYABLE ANTENNA WITH 15-METER ASTROMAST

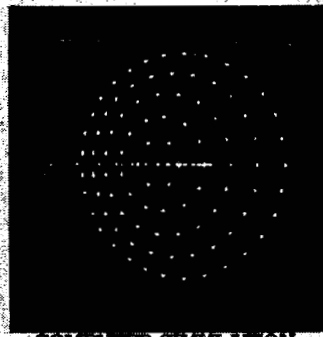

COMPUTER SIMULATION USING STARS

	SIGMA X	SIGMA Y	SIGMA Z
RMS-94 DISH TARGETS:	0.008	0.009	0.008
RMS-9 FEED TARGETS:	0.008	0.049	0.006
RMS-6 ASTROMAST TARGETS:	0.010	0.032	0.008

TOTAL ACCURACY ESTIMATES FOR PHOTOGRAMMETRY SIMULATION

COMPUTER SIMULATION OF THE SHUTTLE BASED CLOSE-RANGE PHOTOGRAMMETRY MEASUREMENT SYSTEM

**SURFACE ACCURACY MEASUREMENT SYSTEM
50 METER TEST RESULTS**

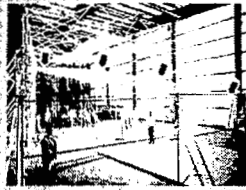

MESH SURFACE

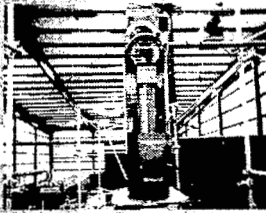

RECEIVER UNIT/ELECTRONICS



LED/MESH TARGET

RECEIVER	RANGE	ACCURACY (RMSE)		
LOCATION	METERS	FEET	MM	INCHES
MESH	18.1	59.4	0.015	0.00064
MESH	18.7	61.3	0.025	0.001170
HOOP	21.0	68.9	0.080	0.003141

SAMS TEST RESULTS

PHOTOGRAMMETRIC MEASUREMENT APPROACH

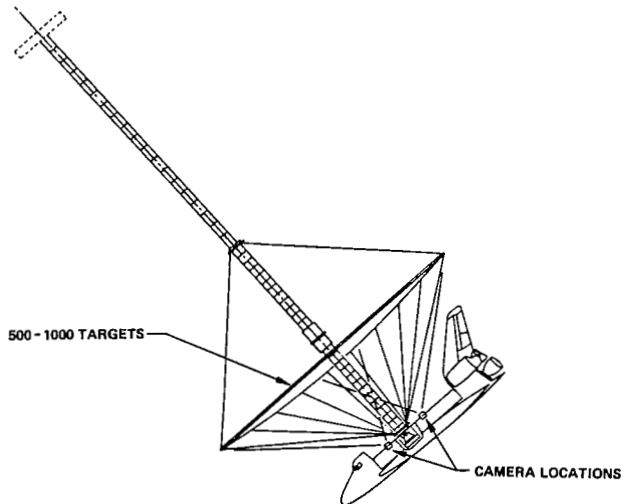

NOTE: STEP should consider incorporating photogrammetry as a standard capability

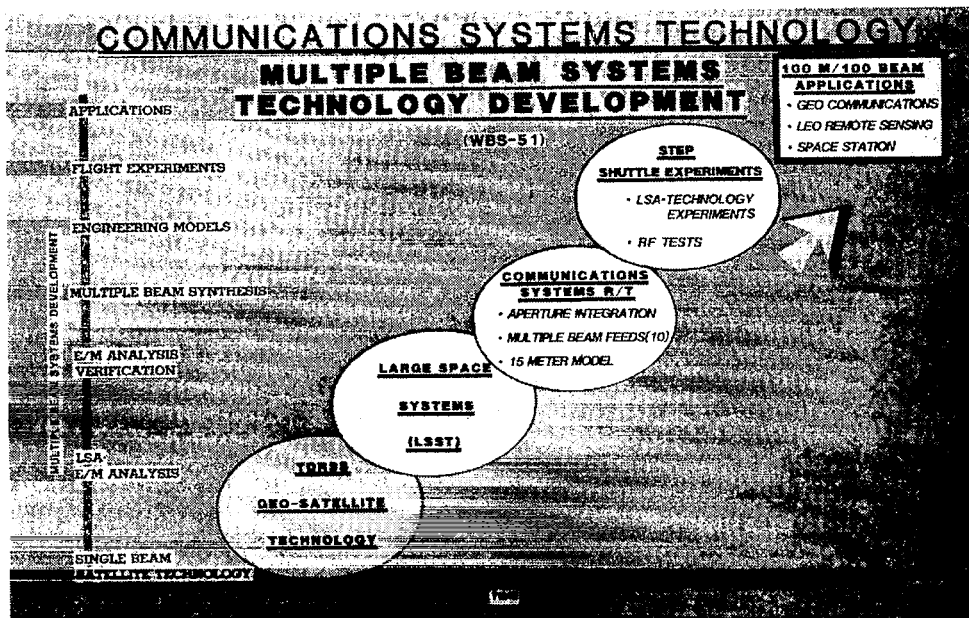
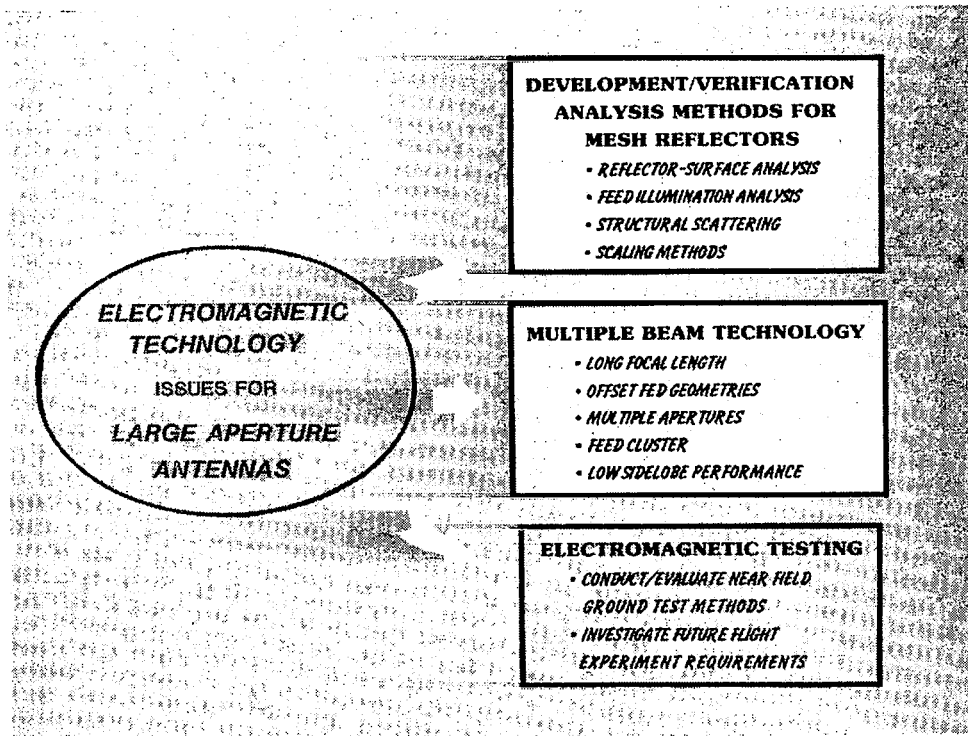

BASIC ELECTROMAGNETIC ISSUES/CONCERNS
FOR THE LSA FLIGHT EXPERIMENT

- VERIFICATION/UPDATE OF ELECTROMAGNETIC ANALYTICAL CODES FOR PREDICTING PERFORMANCE OF LARGE SPACE ANTENNAS.
- SURFACE INACCURACY EFFECTS ON RF PERFORMANCE.
- DEPOLARIZATION EFFECTS (FEED ILLUMINATION, OFF-SET GEOMETRY, MESH CHARACTERISTICS).
- FEED POSITION ACCURACY EFFECTS.
- STRUCTURAL SCATTERING EFFECTS (SIDE LOBE, CABLE, MAST, ETC.).
- BEAM FORMATION QUALITY AND SIDE LOBE CHARACTERISTICS.
- METHODS FOR DETERMINING ANTENNA PERFORMANCE IN ORBIT.

ANTENNA MEASUREMENT TECHNIQUES

- Use of a ground based array.
- Use of a reflecting sphere (balloon) or transmitting source in low earth orbit.
- Use of an available geosynchronous source (e.g. the TDRSS satellite).
- Use of a celestial source (e.g. a radio star).

ANTENNA MEASUREMENT TECHNIQUES

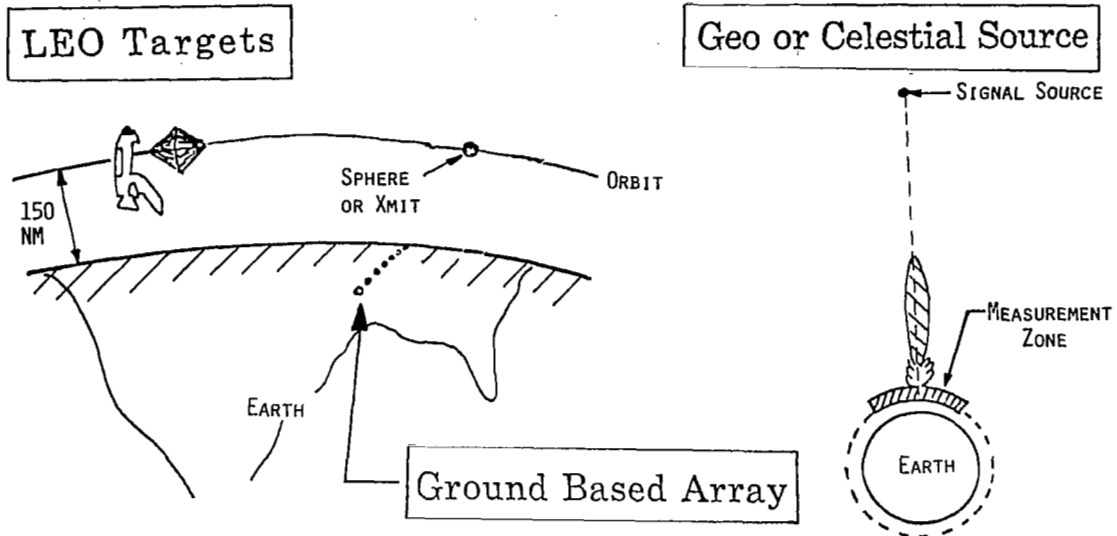

PRELIMINARY ASSESSMENT OF MEASUREMENT TECHNIQUES

TECHNIQUE		ANTENNA PARAMETERS						COMMENTS
		BORESITE TRANSIENT	BORESITE STATIC	SIDELOBES	HEMISPHERIC SCAN	CROSS-POLARIZATION	RASTER ³ SCAN	
CO-ORBITER	LEO-SPHERE	GOOD	EXCELLENT	POOR ¹	MARGINAL ¹	EXCELLENT	POOR ²	RASTER SCAN IS LIMITED BY SETTLE TIME OF STRUCTURE
	LEO-XMIT	EXCELLENT	GOOD	GOOD	EXCELLENT	GOOD	POOR ²	
	GOE-XMIT	EXCELLENT	GOOD	EXCELLENT	EXCELLENT	MARGINAL	POOR ²	
CELESTIAL SOURCES	RADIO STARS	POOR	MARGINAL	POOR	GOOD	MARGINAL	POOR ²	<ul style="list-style-type: none"> ● COMPLEX HARDWARE ● TECHNICAL ISSUES
GROUND BASED SYSTEMS	ARRAY	POOR	MARGINAL	GOOD	GOOD	MARGINAL	EXCELLENT	<ul style="list-style-type: none"> ● LIMITED TEST TIME ● HIGH COST ● NO FULL SUN
	SINGLE STATION	POOR	POOR	MARGINAL	MARGINAL	MARGINAL	POOR	<ul style="list-style-type: none"> ● LIMITED TESTING TIME ● NO FULL SUN

- NOTES:
- 1) MAY BE IMPROVED WITH LARGER TARGET (INFLATABLE - TETHERED SPHERE).
 - 2) MAY BE IMPROVED IF SETTLE TIME IS SHORT.
 - 3) MAY ALLOW MEASUREMENT OF REFLECTOR CONTOUR (HOLOGRAPHIC TECHNIQUE).



PRELIMINARY MEASUREMENT TECHNIQUE ASSESSMENT

- The measurement requirements can be satisfied using several different approaches.
- A short "settling" time (controlled or natural) could provide important raster scan patterns and an RF determination of the reflector contour.
- Use of a celestial source will also provide a demonstration of the Very Long Baseline Interferometer (VLBI) and the Push Broom Microwave Radiometer (PBMR) which are proposed future missions.
- The use of TDRSS as a Geo-Source appears to be the lowest cost approach.

15-METER RF FLIGHT HARDWARE

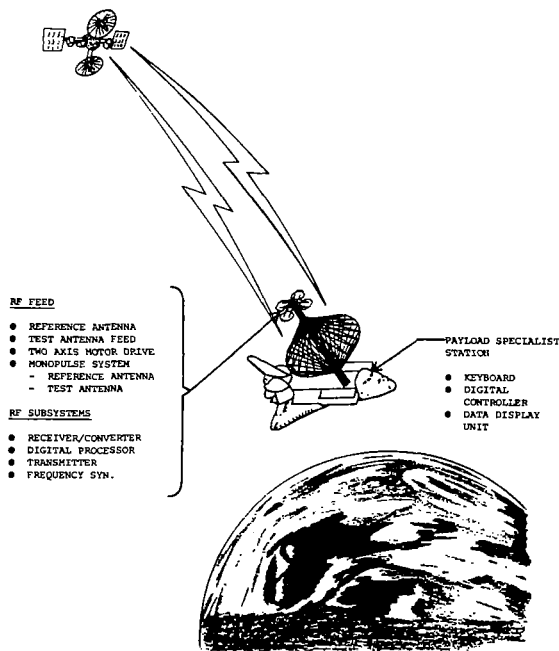

ELECTROMAGNETIC EXPERIMENT PLAN

EXPERIMENT		MEASURED PARAMETER	TEST CONDITIONS
1	PATTERN DETERMINATION	ANTENNA PATTERN	<ul style="list-style-type: none"> ● FULL SUN ● EDGE-ON SUN
2	BORESITE TRANSIENT	BORESITE GAIN AND ANGLE	<ul style="list-style-type: none"> ● NO SUN
3	THERMAL TRANSIENT		<ul style="list-style-type: none"> ● NEAR OCCULTATION ● EDGE-ON TO FULL SUN
4	APERTURE ILLUMINATION	ANTENNA PATTERN	<ul style="list-style-type: none"> ● NO SUN
5	SURFACE ROUGHNESS EFFECTS		<ul style="list-style-type: none"> ● NO SUN

DTS-FEED PANEL CONFIGURATION

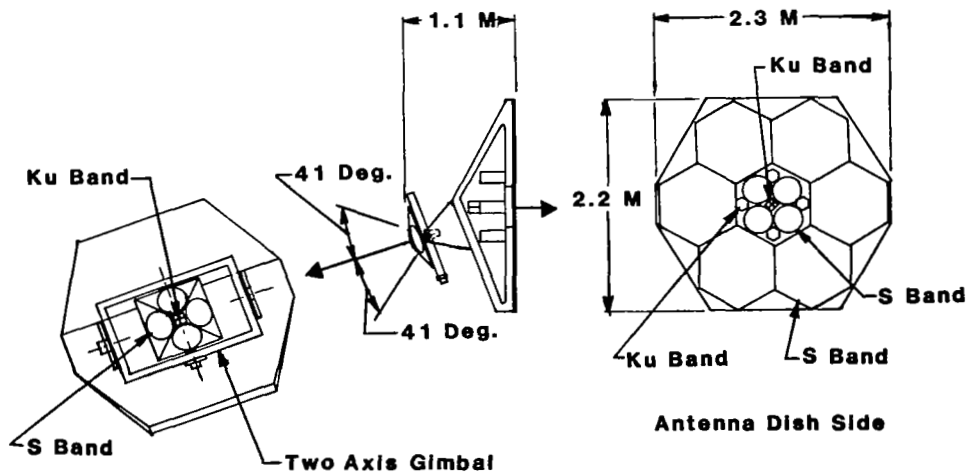

MULTIPLE BEAM PATTERNS FROM QUAD-APERATURE

15-METER MODEL

Interleaved
Beam Patterns

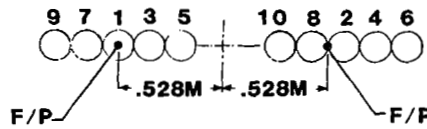
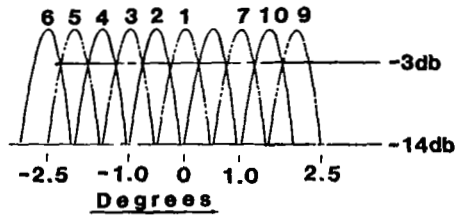

Multiple Beam
Feed Locations

15-M MODEL

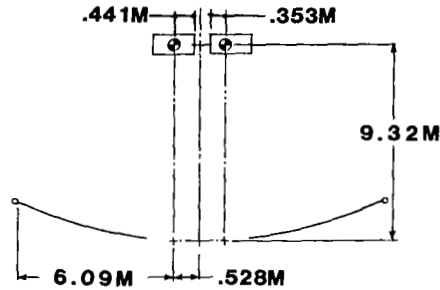

MAIN REFLECTOR with 14 dB HORN FEED

(E and H Planes Asymmetric)

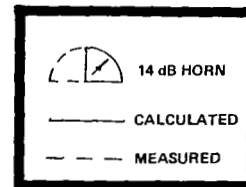
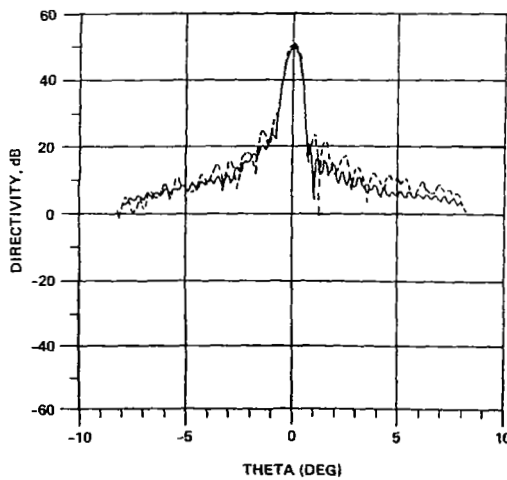

STRUCTURAL/DYNAMICS AND CONTROLS TEST

- Determine the structural/dynamic characteristics (frequencies, mode shapes, damping) of the antenna in the space environment.
- Validate the structural dynamic analytical techniques and modeling.
- Verify test techniques for orbiter-attached LSS.
- Verify controls technology for LSS.
 - Shape Control Techniques and Algorithms
 - Vibration Control
 - Pointing Control
 - Control System Algorithms
 - Sensor and Actuator Performance
 - Control System Robustness

THE 3-PHASE STRUCTURAL/DYNAMICS TEST PLAN ALLOWS CONTROL OVER THE COMPLEXITY AND COST OF THE EXPERIMENT

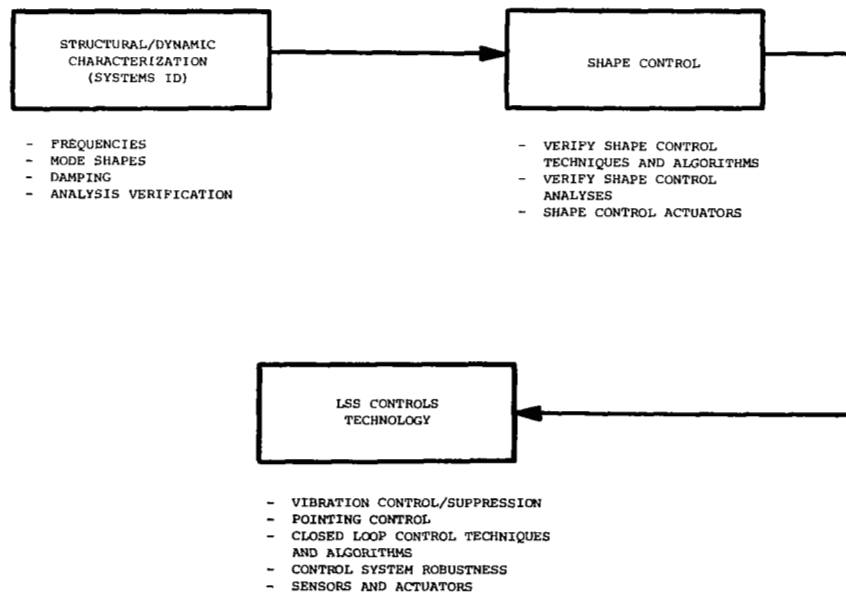

EXPERIMENT PHASE I
OPEN LOOP SYSTEM ID
HOOP/COLUMN

- OBJECTIVES
 - ESTIMATION OF TRANSFER FUNCTIONS FOR INERTIA ACTUATORS
 - ESTIMATION OF MODAL FREQUENCIES AND DAMPING
 - ASSESSMENT OF NONLINEARITIES
- SEQUENCE (ANTENNA FULLY DEPLOYED AND PRETENSION VERIFIED)
 - RANDOMLY EXCITE STRUCTURE BY ONE ACTUATOR AT A TIME IN SEQUENCE ⑤, ④, ③, ②, ① AND ⑦ - ⑥
 - RECORD DATA AND TRANSMIT TO GROUND STATION
 - PERFORM SYSTEMS ID
 - COMPARISON WITH ANALYTICAL MODELS

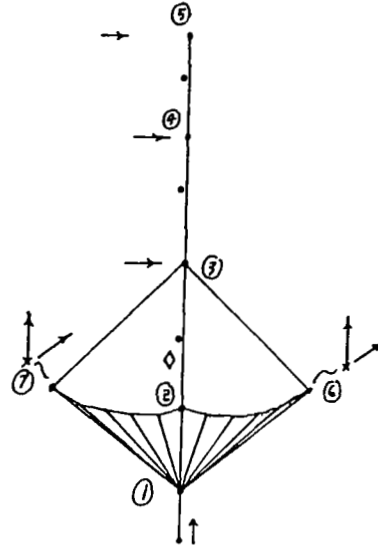

- SURFACE LINEAR ACTUATOR
- X INCHWORM (ARCHED DRAWING CORDS)
- ◇ PASSIVE/ACTIVE PIEZOELECTRIC DAMPER
- LINEAR MOMENTUM PROOF MASS ACTUATOR
- MOMENTUM WHEEL OR CMG

EXPERIMENT PHASE II

PSEUDO STATIC SHAPING

OBJECTIVES

- VERIFY PERFORMANCE OF SHAPE CONTROL SYSTEM FOR STATIC SHAPING (I.E., ALGORITHM, SENSORS AND ACTUATORS)
- VERIFY PLACEMENT AND NUMBER OF SENSORS, ACTUATORS

SEQUENCE

- SURFACE FIELD MEASURE (PHOTOGRAMMETRY)
- SHAPE CONTROL CYCLE WITH ON-BOARD SENSORS
- SURFACE FIELD MEASUREMENT
- MOVE SURFACE TO KNOWN DISTORTED SHAPES USING ON-BOARD SENSORS
- SURFACE FIELD MEASUREMENT

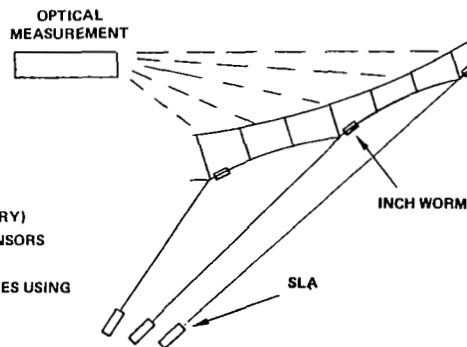

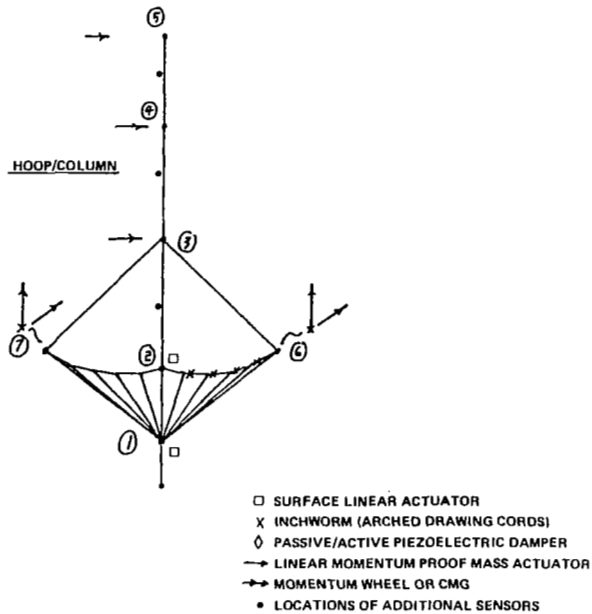

EXPERIMENT PHASE III
 DYNAMIC CONTROL TEST

- OBJECTIVE. VALIDATE THE CONTROL DESIGN
- SEQUENCE
 - FINE POINTING
 - CLOSED LOOP BEFORE END OF VRCS FIRING TRANSIENT DELAY
 - COMPARE TO OPEN LOOP RESPONSE
 - SUPPRESSION OF TRANSIENTS
 - DISCRETE LOCATION PULSE EXCITATION WITH CMG
 - END OF SLEW MANEUVER WITH CLOSED LOOP SYSTEM
 - VIBRATION SUPPRESSION
 - CONTROL SYSTEM (INCLUDING SURFACE ADJUSTMENT ACTUATORS)
 - EXCITE HOOP OR MAST
 - SURFACE FIELD MEASUREMENT FOR SURFACE VALIDATION
 - STRUCTURAL MODEL VALIDATION SYSTEMS ID
 - OPEN LOOP SYSTEM IDENTIFICATION (2-4 EXCITATION LOCATIONS)
 - CLOSED LOOP SYSTEM IDENTIFICATION
 - USE OF ALTERNATE SYSTEMS IDENTIFICATION ALGORITHMS (TO BE SELECTED)
 - CONTROL SYSTEM ROBUSTNESS
 - PLANT DISCRETE MODIFICATIONS (ELEMENT CHANGES)
 - SYSTEMS ID CYCLE
 - PLANT CONTINUOUS MODIFICATIONS (TENSION CHANGES)
 - SYSTEMS ID CYCLE
 - CONTROLLER MODIFICATION GAINS
 - SYSTEMS ID CYCLE

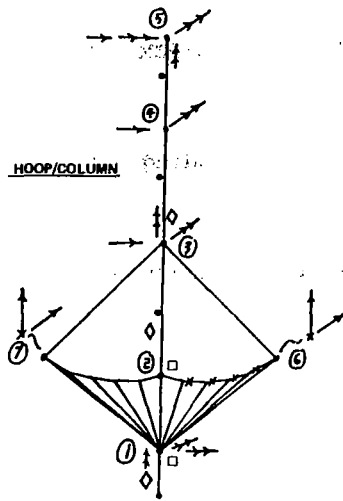

- SURFACE LINEAR ACTUATOR
- X INCHWORM (ARCHED DRAWING CORDS)
- ◇ PASSIVE/ACTIVE PIEZOELECTRIC DAMPER
- LINEAR MOMENTUM PROOF MASS ACTUATOR
- MOMENTUM WHEEL OR CMG
- LOCATIONS OF ADDITIONAL SENSORS

15-METER MODEL SUITABILITY AS A CONTROLS TECHNOLOGY TEST ARTICLE

FEATURE

- HAS A NUMBER OF LOW FREQUENCY (<1 Hz) MODES WHICH ARE CLOSELY SPACED.
- HAS A PRECISION REFLECTOR SURFACE WHICH IS ADAPTABLE TO ACTIVE ADJUSTMENT.
- DYNAMIC CHARACTERISTICS CAN BE VARIED BY CHANGING CORD TENSION AND/OR BY ADDING DISCRETE VARIABLE SPRING/DAMPERS IN CORDS.
- AUTOMATIC AND CONTROLLED DEPLOYMENT AND RESTOW CAPABILITY.
- HARDWARE PRESENTLY BEING DEVELOPED AND TESTED ON OAST FUNDED PROGRAM.

BENEFIT

- DYNAMIC CHARACTERISTICS OF THE 15 METER MODEL ARE REPRESENTATIVE OF LSS.
- ALLOWS FIGURE CONTROL TECHNOLOGY DEVELOPMENT AND VERIFICATION.
- PROVIDES A VARIABLE TEST ARTICLE FOR EVALUATION OF CONTROL SYSTEM ROBUSTNESS.
- ALLOWS CLOSER REPRESENTATION OF THE DYNAMIC CHARACTERISTICS OF LSS (E.G. 122 METER REFLECTOR).
- ALLOWS EVALUATION AND ASSESSMENT OF DEPLOYMENT AND RETRACTION DYNAMICS AND CONTROL.
- PROVIDES A LOW-COST, LOW-RISK TEST ARTICLE FOR DEVELOPMENT AND VERIFICATION OF LSS CONTROLS TECHNOLOGY AND TEST TECHNIQUES.

EXPERIMENT REQUIREMENTS

Physical Requirements:

Weight: 1200 to 1400 Lbs (excluding STEP).

Envelope:

Stowed: Right circular cylinder of 2 meter diameter and 4 meter length.

Deployed: See next figure.

APPROXIMATE DEPLOYED ENVELOPE

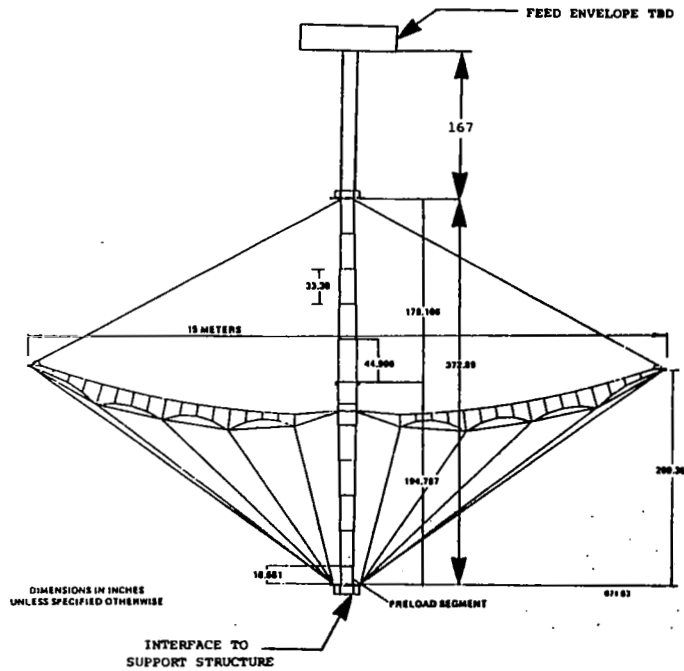

EXPERIMENT REQUIREMENTS

POWER:

DEPLOYMENT	400 WATTS
AF	300 WATTS
SURFACE MEASUREMENT	100 WATTS
INSTRUMENTATION	300 WATTS
CONTROL ACTUATORS	500 WATTS

INSTRUMENTATION:

100 THERMISTORS
60 ACCELEROMETERS
60 STRAIN GAGES
4 LOAD CELLS

DATA RATE:

60 KBSP

OTHER:

EXPERIMENT WILL REQUIRE VIDEO RECORDING OF
CCTV DURING SOME PHASES OF THE EXPERIMENT.

EXPERIMENT REQUIREMENTS

Commands (Number, type, stored, by telemetry)

Typical commands required would be:

- Initiate Deployment
- Stop Deployment
- Initiate Retraction
- Stop Retraction
- RF Power On
- RF Power Off
- Jettison
- Initiate Dynamics/Controls Experiment
- Stop Dynamics/Controls Experiment

MISSION REQUIREMENTS

Duration: 7 Days

Altitude: 300 KM

Inclination: TBD

Eccentricity: TBD

Altitude Pointing and Stabilization: TBD

SUMMARY

- *PRELIMINARY LDAF EXPERIMENT STUDIES INDICATE NO SIGNIFICANT INCOMPATIBILITY WITH STEP CAPABILITIES AND INTERFACE REQUIREMENTS.*
- *FURTHER REFINEMENT OF THE LDAF EXPERIMENT WILL SUBSTANTIALLY INFLUENCE THE REQUIREMENTS DEFINITION FOR STEP.*
- *LDAF EXPERIMENT ALLOWS FULL UTILIZATION/CHECKOUT OF STEP CAPABILITIES.*
- *LDAF EXPERIMENT PROVIDES HIGH RETURN IN DYNAMICS/CONTROLS AND ELECTROMAGNETIC TECHNOLOGIES FOR LARGE ANTENNAS.*

CONCERNS

- ***ELECTROMAGNETICS EXPERIMENT MAY REQUIRE A ROTATIONAL AND POINTING CAPABILITY NOT PRESENTLY AVAILABLE ON STEP.***
- ***EMI/EMC ISSUES WITH AN ACTIVE RF EXPERIMENT ON STEP MUST BE ADDRESSED.***
- ***STS SAFETY AND OPERATIONAL REQUIREMENTS MUST BE ADDRESSED.***
- ***MULTIPLE EXPERIMENT FLIGHTS MAY BE REQUIRED TO FULLY ADDRESS THE LARGE ANTENNA DEPLOYMENT/ STRUCTURAL/DYNAMIC/CONTROLS - AND EM TECHNOLOGIES.***
- ***STEP SHOULD CONSIDER INCORPORATING PHOTOGRAMMETRY AS A STANDARD CAPABILITY.***

55-METER-STRUCTURE FLIGHT EXPERIMENT

John A. Garba, Robert Freeland, and Ben K. Wada
Jet Propulsion Laboratory
Pasadena, California

Kirk J. O'Keefe and Art Woods
Lockheed Missile and Space Company
Sunnyvale, California

PURPOSE

VERIFICATION AND DEMONSTRATION OF STRUCTURAL
PERFORMANCE RELATED PARAMETERS FOR LARGE
FLEXIBLE STRUCTURES.

OBJECTIVES

- VERIFY DEPLOYMENT REPEATABILITY OF STATIC SURFACE CONTOUR.
- DEMONSTRATE FEASIBILITY OF IN-FLIGHT STATIC SHAPE CORRECTION.
- VERIFY PREDICTED SHAPE IN A ZERO G THERMAL ENVIRONMENT.
- DETERMINE ZERO G STRUCTURAL DYNAMIC CHARACTERISTICS.
- VERIFY DYNAMICS DURING DEPLOYMENT.
- VERIFY THE INSTRUMENTATION AND EXCITATION SYSTEM FOR IN-FLIGHT MEASUREMENTS.
- VERIFY IN-FLIGHT SYSTEM ID METHODS . . .

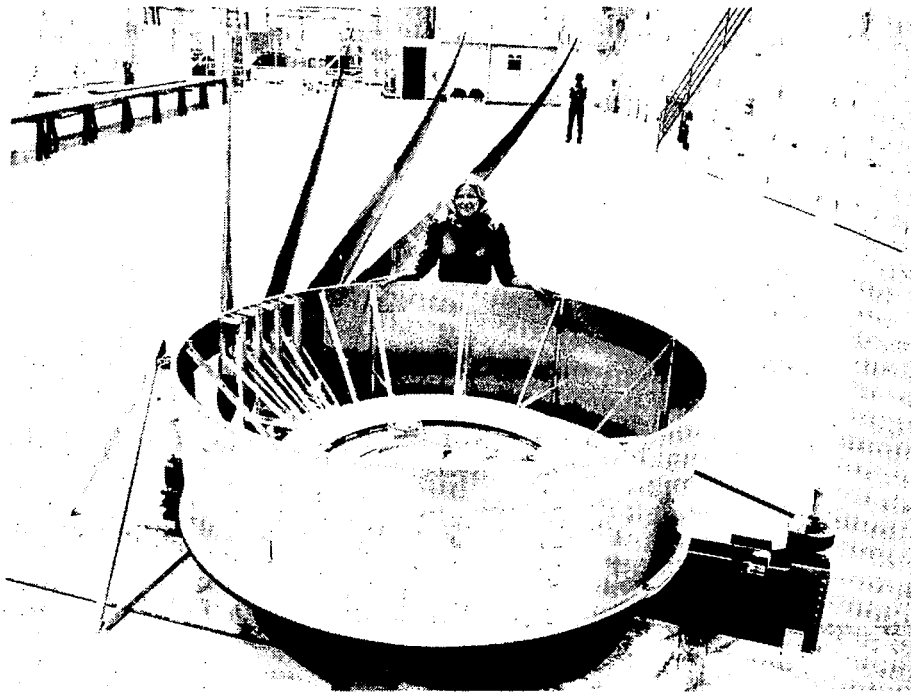
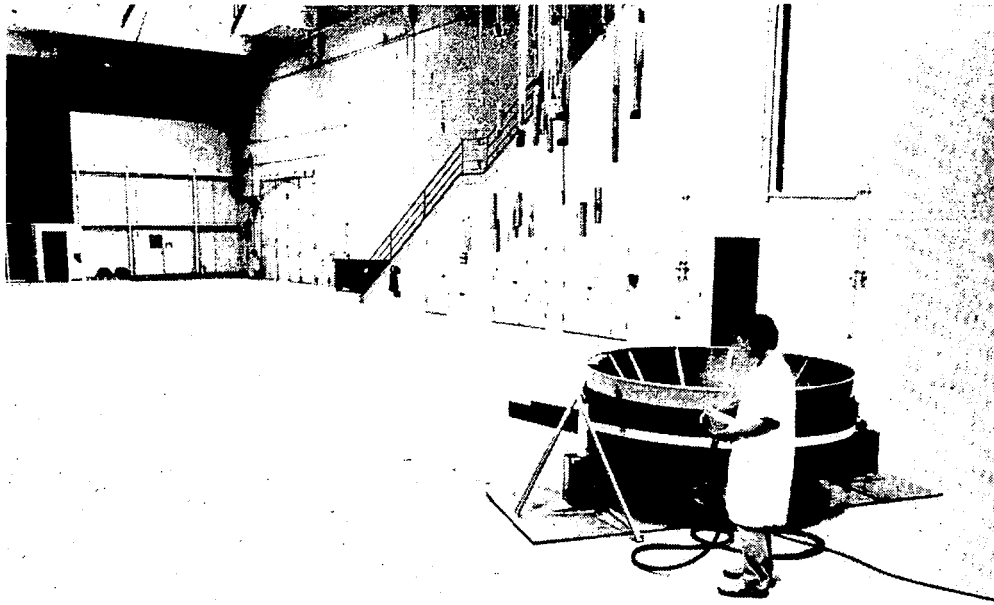

STOWED EXPERIMENT

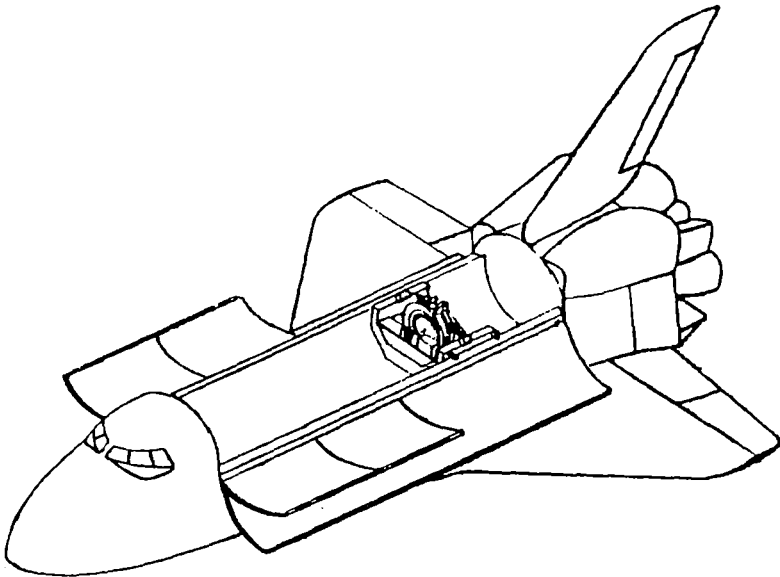

EXPERIMENT (EXCLUDING STEP)

WEIGHT 330 KG

SIZE 2.0 X 2.8 X 2.9 M

DEPLOYED EXPERIMENT

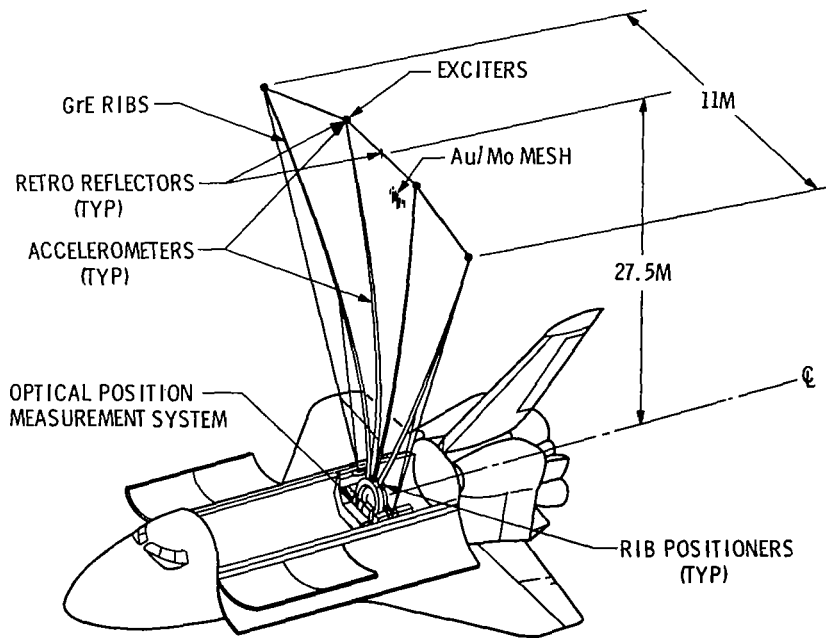

BLOCK DIAGRAM

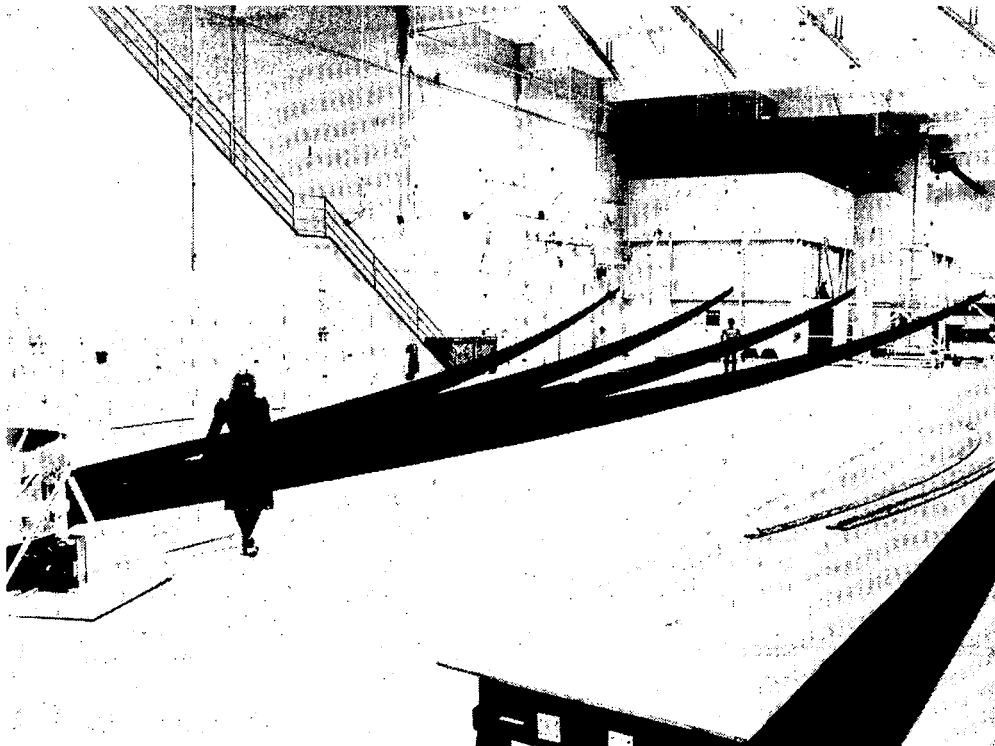
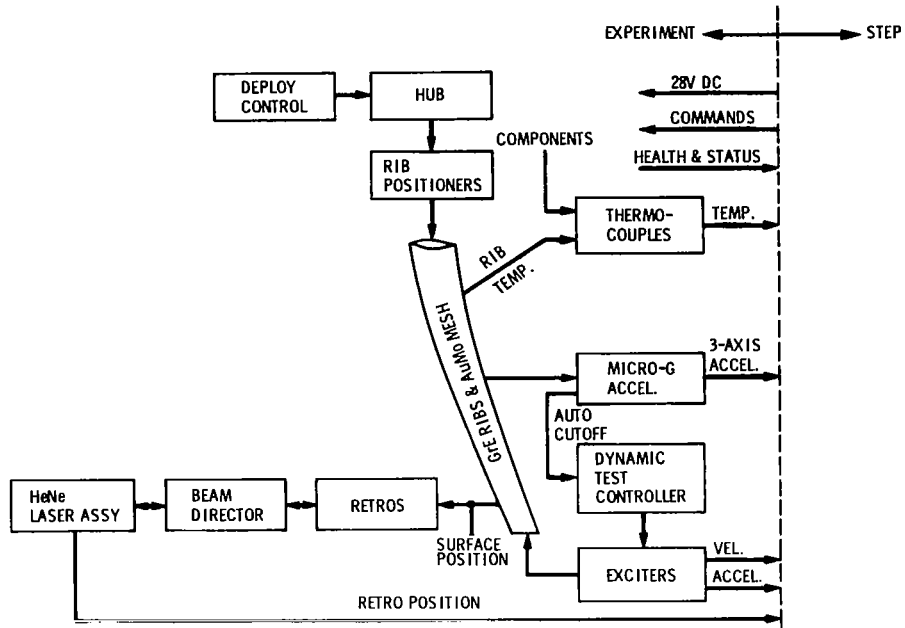

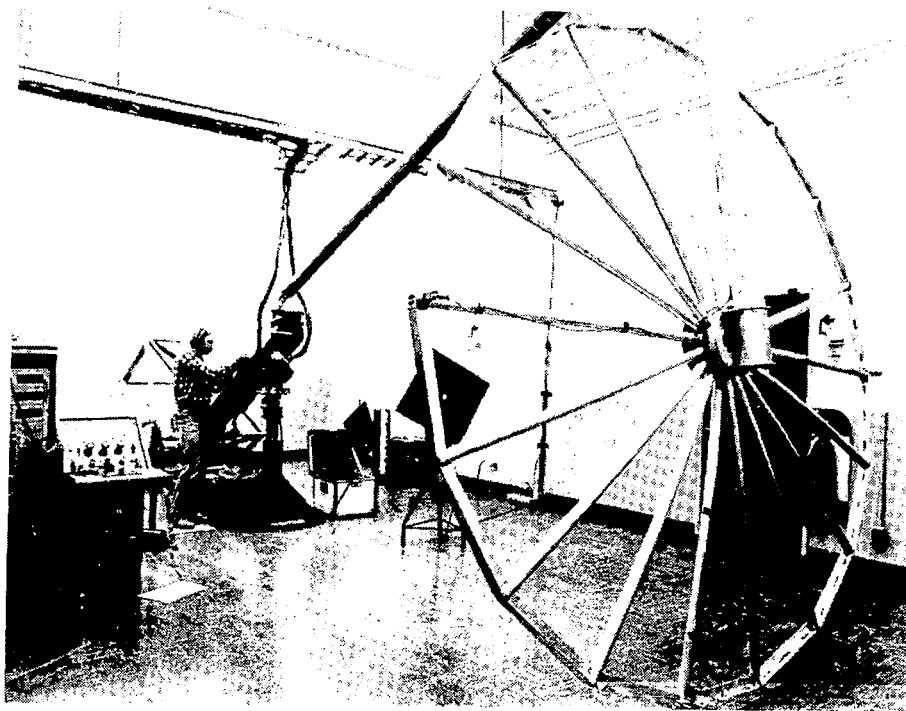
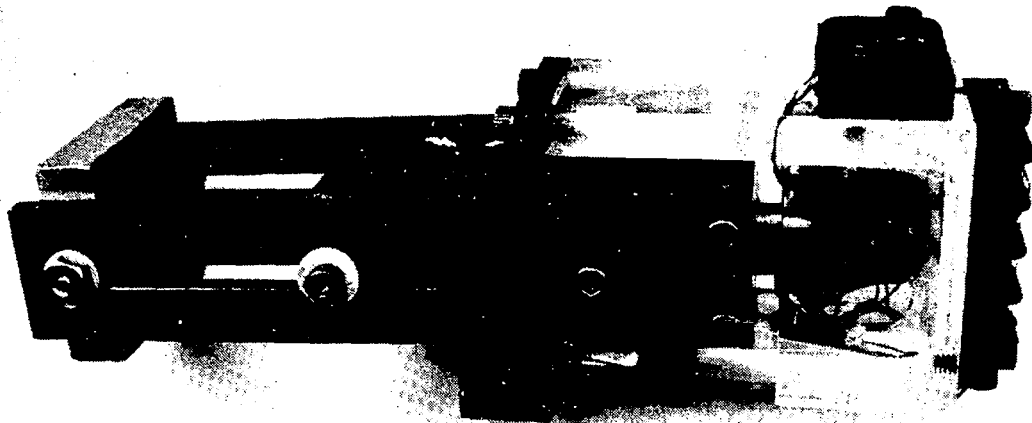

TASKING SEQUENCE

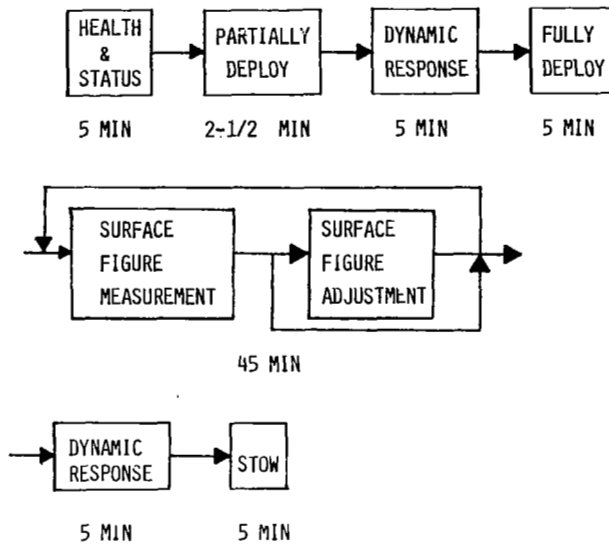

OPERATIONS

- MISSION REQUIREMENTS

- ANY ORBIT
- DURATION \leq 3 DAYS
- \geq 3 TASKINGS
- 4 ORBITER ORIENTATIONS/TASKING
- 3 REVS/TASKING

DATA HANDLING, STORAGE AND COMMANDS

DATA HANDLING

<u>TYPE</u>	<u>SAMPLE RATE</u>	<u>QUANTITY</u>
8 BIT ANALOG	1 SPS	12
8 BIT ANALOG	10 SPS	23
8 BIT ANALOG	500 SPS	22
12 BIT MAGNITUDE	.02 SPS	1
1 BIT DISCRETE	1 SPS	20

STORAGE

ORBITER DATA	STS GMT OR MET
	STS NAV DATA
DYNAMIC RESPONSE	100 KBPS @ 30 MINUTES
OTHER	1 KBPS @ > 207 MINUTES

COMMANDS

- 10 HIGH LEVEL DISCRETE COMMANDS
- 16 LOW LEVEL DISCRETE COMMANDS
- TIMING GRANULARITY 1 SECOND
- COMMAND EVENTS 30 OVER 79 MINUTE PERIOD

OPERATING POWER

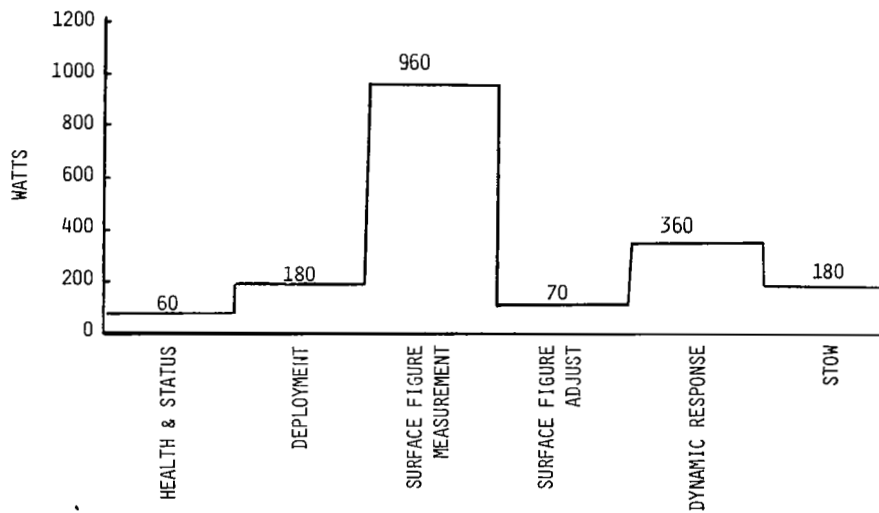

KEY HARDWARE STATUS

<u>COMPONENT</u>	<u>DEVELOPMENT STATUS</u>	<u>FUNDING STATUS</u>
STRUCTURE - 4 RIB/3 GORE 55 M REFLECTOR SEGMENT ASSEMBLY	ECD - DEC. 1983	NASA FUNDED
OPTICAL POSITION MEASURE- MENT SYSTEM	BREADBOARD COMPLETED 1982	INDUSTRY IR&D
DYNAMIC EXCITERS - PIVOTED PROOF MASS ACTUATORS	PROTOTYPE COMPLETED 1981	DARPA AND INDUSTRY IR&D
INSTRUMENTATION	OFF THE SHELF	VENDOR

PROGRAM APPLICATIONS

<u>MISSION NAME</u>	<u>START DATE</u>
MOBILE COMMUNICATIONS PROGRAM	1983
ADVANCED COMMUNICATION TECHNOLOGY SATELLITE	1983
ORBITING VLBI OBSERVATORY	< 1990
FAA SPACE RADAR SYSTEM	> 1990
ORBITING DEEP SPACE RELAY STATION	> 1990

SUMMARY

- MEETS ALL STEP CONSTRAINTS
- "EXISTING" STRUCTURE FOR EXPERIMENT
- STATE-OF-ART PROVEN SUPPORT EQUIPMENT
- VALID FOR WRAP-RIB CONCEPT AND "GENERAL" STRUCTURES
- DEMONSTRATION + TECHNOLOGY (VALID NEED FOR SPACE)
- EXPANDABLE FOR STRUCTURES/CONTROL

TECHNICAL

- ABILITY TO MANUFACTURE , INSPECT AND GROUND TEST
- STATIC AND DYNAMIC SHAPE MEASUREMENT
- THERMAL
- STATIC SHAPE ADJUSTMENT
- DYNAMIC CHARACTERISTICS
- APPLY FORCE
- DEPLOYMENT DYNAMICS
- SYSTEM ID
- DIRECT STEP FOR STRUCTURE/CONTROL
- INFLUENCE OF SHUTTLE ON ATTACHED LARGE FLEXIBLE STRUCTURE
- EVALUATE ROLE OF GROUND/SPACE TEST

LARGE INFLATED-ANTENNA SYSTEM

W. F. Hinson and L. S. Keafer
NASA Langley Research Center
Hampton, VA

LARGE INFLATED-ANTENNA CONCEPT

The large inflated-antenna concept is shown below in Figure 1.

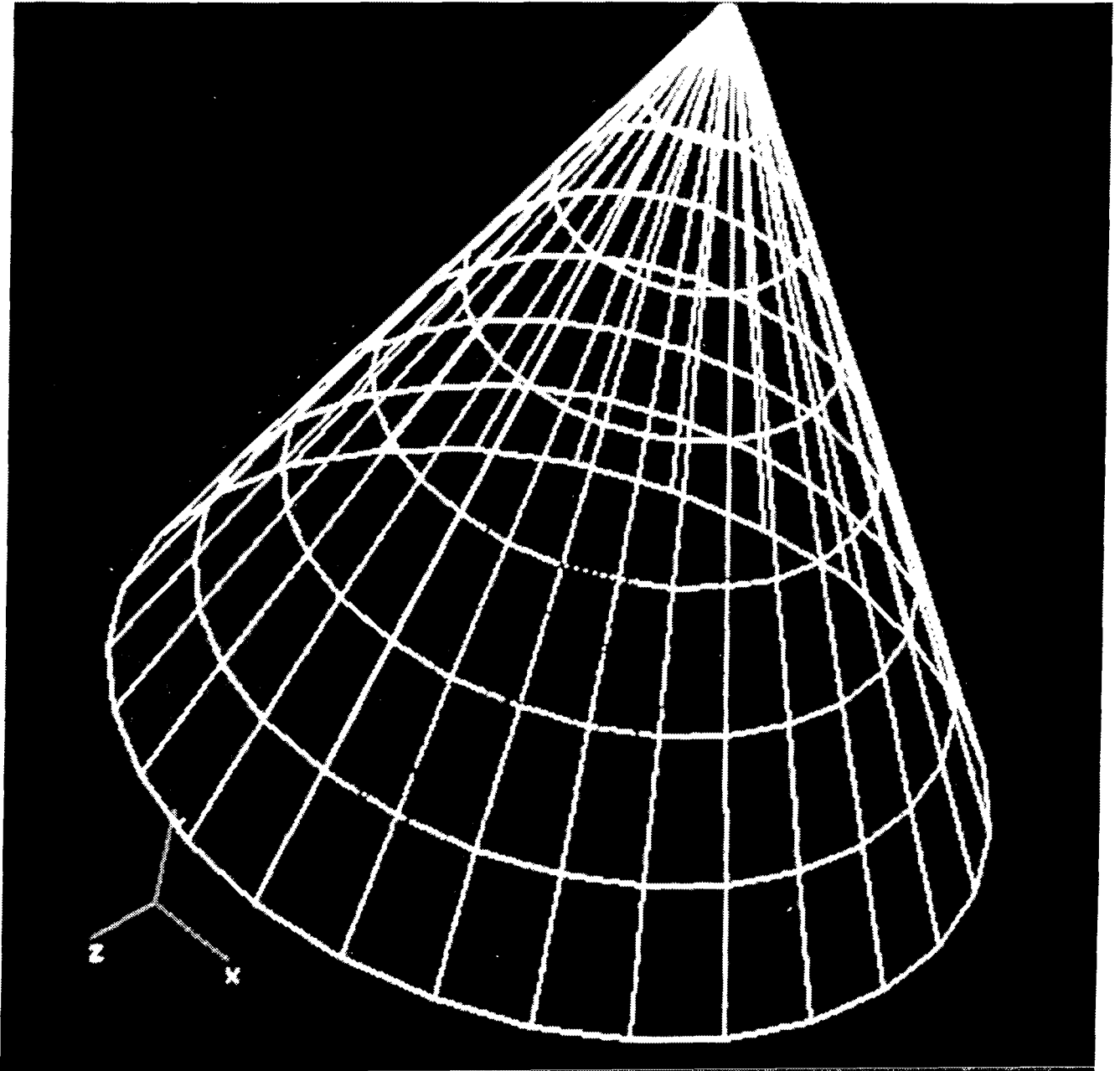

Figure 1

ANTENNA CONFIGURATION

The antenna configuration (Fig. 2) consists of a thin film cone and paraboloid held to proper shape by internal pressure and a self-rigidizing torus. The cone and paraboloid would be made using pie-shaped gores with the paraboloid being coated with aluminum to provide reflectivity. The torus would be constructed using an aluminum polyester composite that when inflated would erect to a smooth shell that can withstand loads without internal pressure (see reference 1).

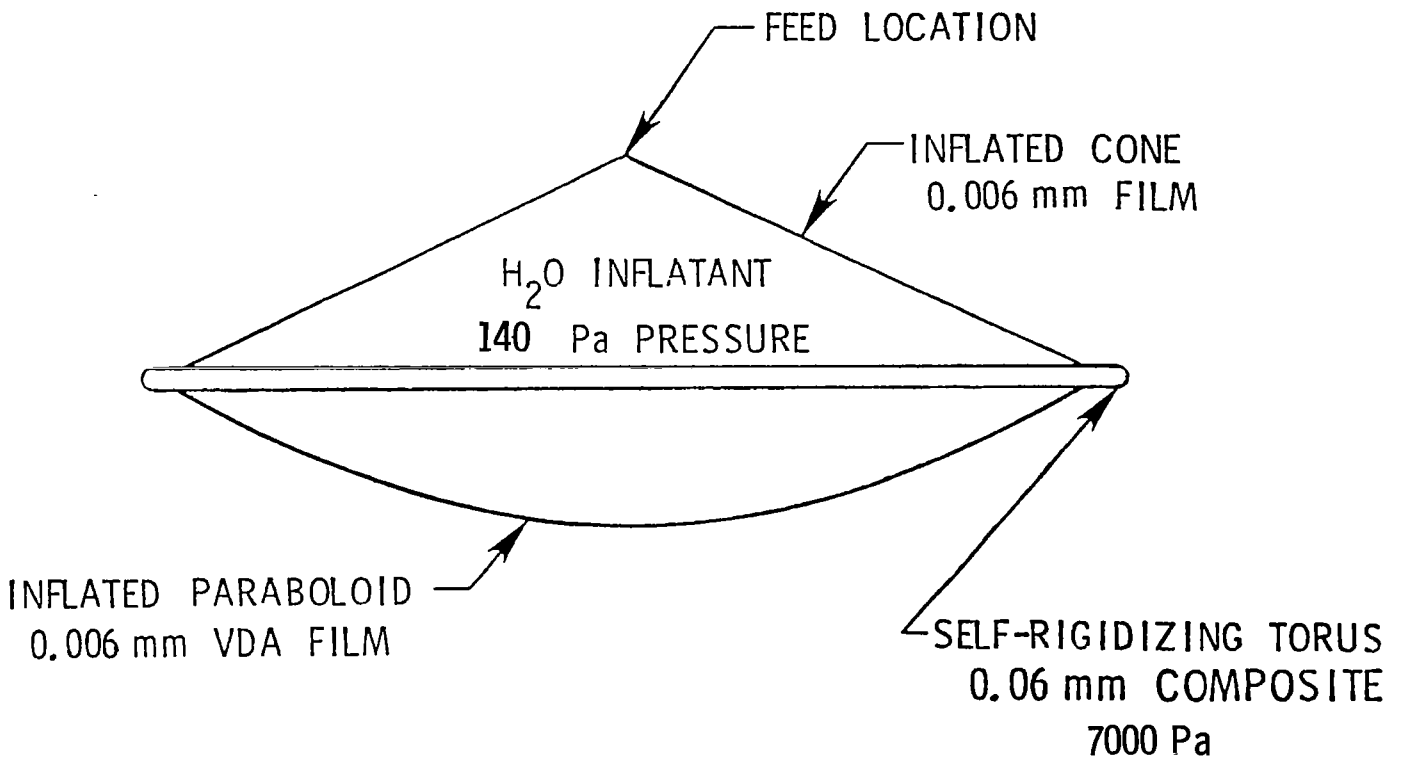

Figure 2

INFLATED-ANTENNA SHUTTLE CONFIGURATION - CUP UP

The inflated antenna (16 m diameter, focal length to diameter, $f/D = 1$) is shown attached to the Shuttle (Fig. 3). Two photogrammetric cameras will measure the dish contour accuracy. The feed alignment will be measured with a simple optical system. Antenna pattern and radio frequency (rf) gain measurements will be made using a ground station or geosynchronous target such as TDRSS. An alternative antenna attachment to the Shuttle might be at the apex of a cone designed to support an offset feed arrangement (cup down). This installation procedure would locate the major antenna mass at the point of attachment.

One objective of the large inflated-antenna system is to demonstrate the technological feasibility of inflatable systems for large space reflecting antennas such as required by the Voice of America for worldwide sound broadcast at 26 MHz.

A second objective is to validate design parameters in ground and flight tests affecting skin stress, surface accuracy, and feed alignment in scaling to typical operational antenna sizes.

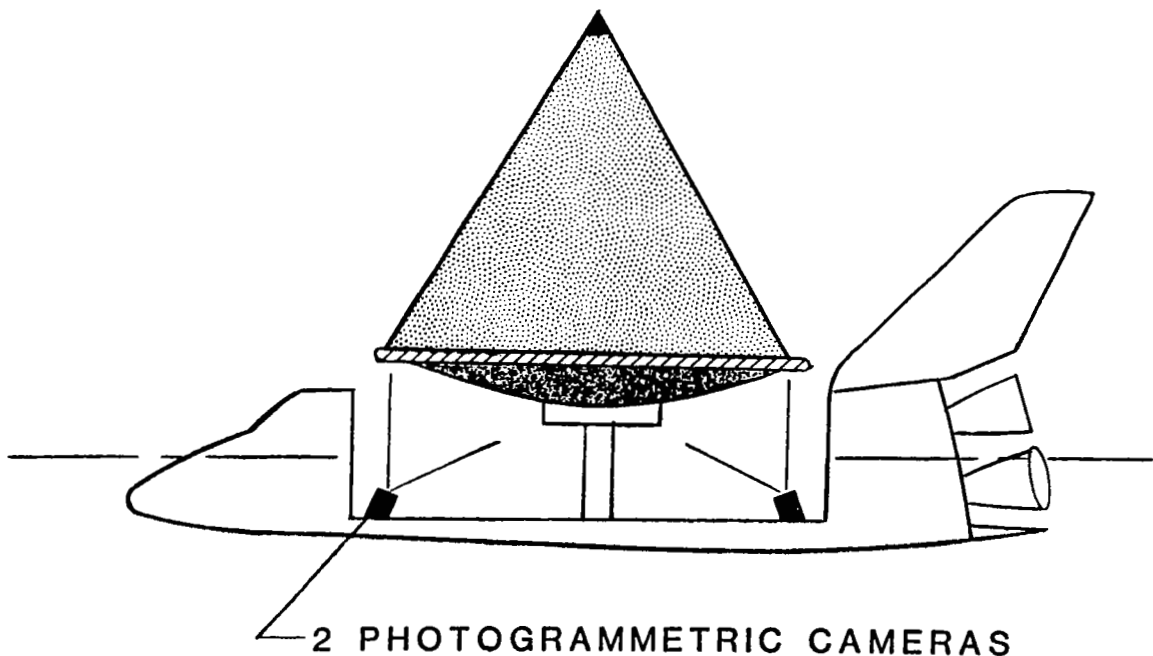

Figure 3

INFLATABLE STRUCTURE HISTORY

The purpose of Figure 4 is to present a general picture of the time span for basic research, development, and application conducted on inflatable devices for aerospace projects by NASA and industry. The figure shows an extensive amount of work between the late 1950's and the early 1970's on several innovative structural systems. A cross section of the documentation of the work is presented in reference 1. Applications were in the fields of determining atmospheric density, communications, and geodetic measurements. A one-man inflatable plane was built and flight tested.

The latest projects using inflatable technology conducted by NASA in the 1970's were a blanket (solar shield) for Skylab and a 3.66-meter-diameter balloon for upper atmospheric density research. The blanket was approximately 2 mils thick and 6.09 meters square and was made from one layer of polyester covered on both sides with a layer of aluminum foil. Inflatable tubes were attached to the upper and lower surfaces of the flat sheet for erection.

The 3.66-meter orbital balloon differed from previous balloon designs in that the surface of the balloon had one-percent surface area perforations. A 5-ply laminate (2 layers of polyester and 3 layers of aluminum foil) was used to construct the balloon. Inflation was by staged mass flow rates of compressed nitrogen gas.

Some inflated-reflector-antenna work was conducted by NASA in the late 1950's and since that time other projects have been considered by industry including a cone-paraboloid concept by L'Garde, Incorporated, in 1982 (reference 2).

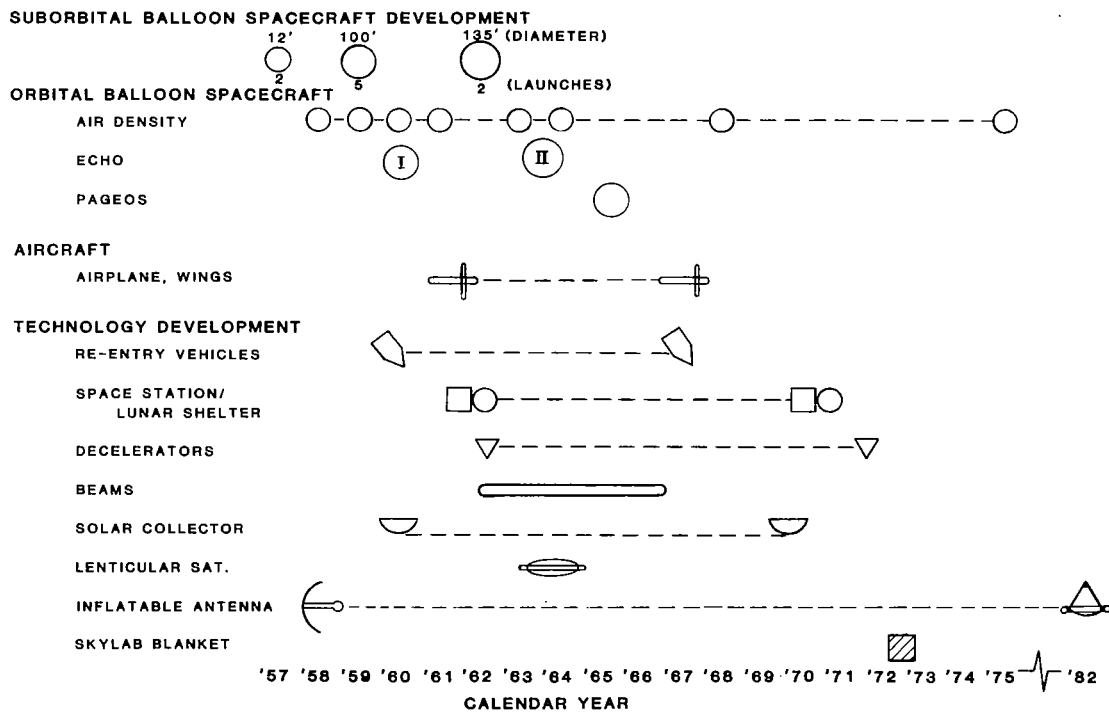

Figure 4

1958 INFLATABLE ANTENNA SYSTEM

The purpose of this antenna system was to investigate fabrication techniques in establishing procedures for forming, cutting, sealing, and handling; to evaluate manufacturing procedures by constructing models using flat surfaces or curved mandrels and molds; and to determine the number of gores, thicknesses, and types of laminated materials.

The reflector shown in Figure 5 was approximately 3.66 meters in diameter and was constructed using a polyester and aluminum foil laminate approximately 2 mils thick. The front surface material was 1/2-mil-thick plain polyester. Pressure in the antenna and torus was approximately 689 Pa.

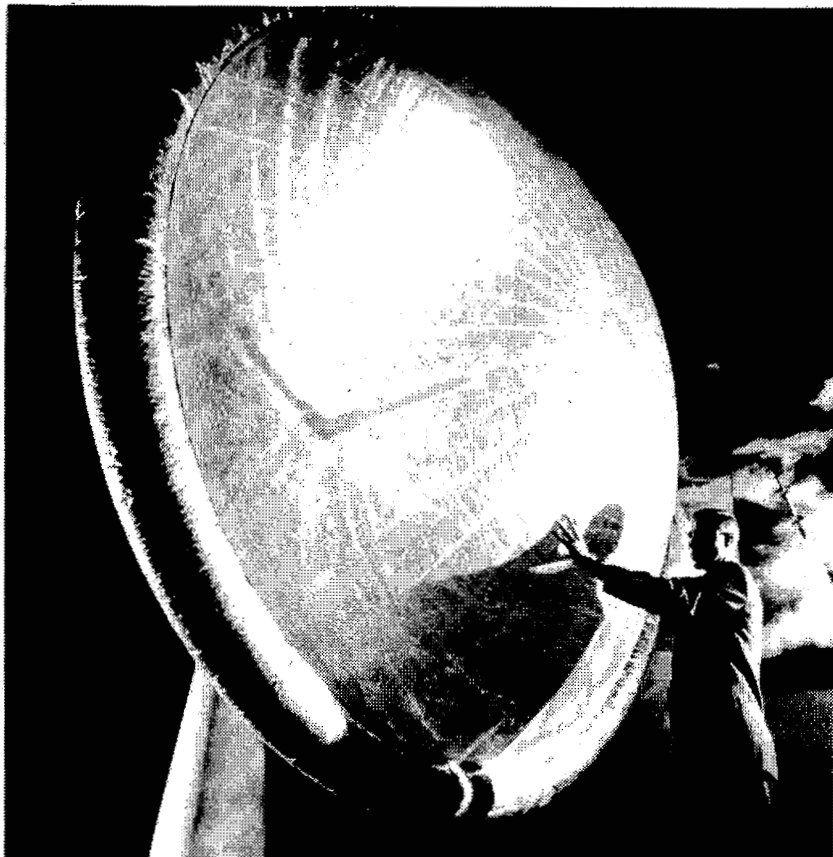

Figure 5

1963 INFLATABLE ANTENNA SYSTEM

This antenna system (Fig. 6) is discussed in detail in reference 1. In general, the antenna when inflated measured approximately 3 meters in diameter and could be packaged in a container 25.4 by 25.4 by 17.8 cm. Weight was approximately 3.6 kg. The antenna structure was measured to be within a tolerance of 1.58 mm. Material used was a polyester and aluminum foil laminate (1 mil thick) for the reflector and plain polyester (1/2 mil thick) for the front surface. Inflation was by compressed nitrogen gas at a pressure of 2482 Pa.

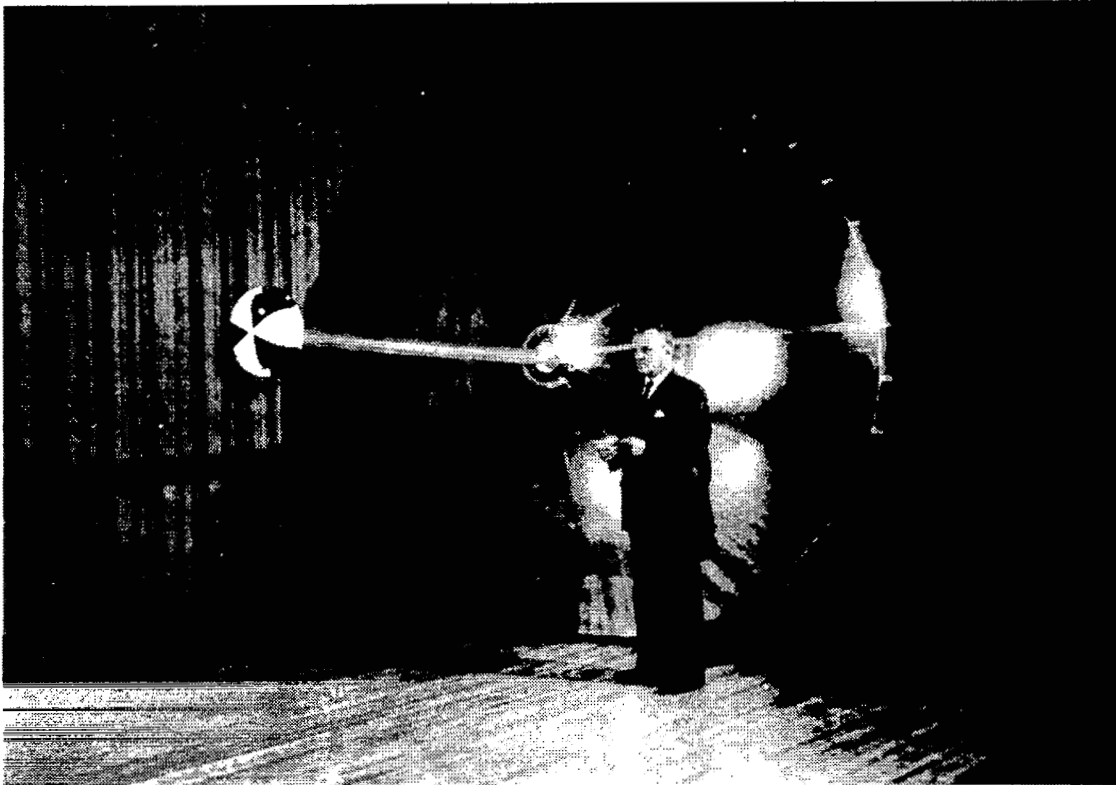

Figure 6

INFLATED PARABOLOID

The paraboloid shown in Figure 7 is 3 meters in diameter and was designed to have an f/D of one. It is made from 32 gores of 0.006-mm (1/4-mil) VDA polyester. The gores were assembled with 19-mm-wide tape of 0.013-mm polyester and 0.013-mm heat sensitive adhesive. The paraboloid was accuracy tested at 2.5-mm H₂O (0.003 psi) pressure (near optimum) and then at twice that pressure.

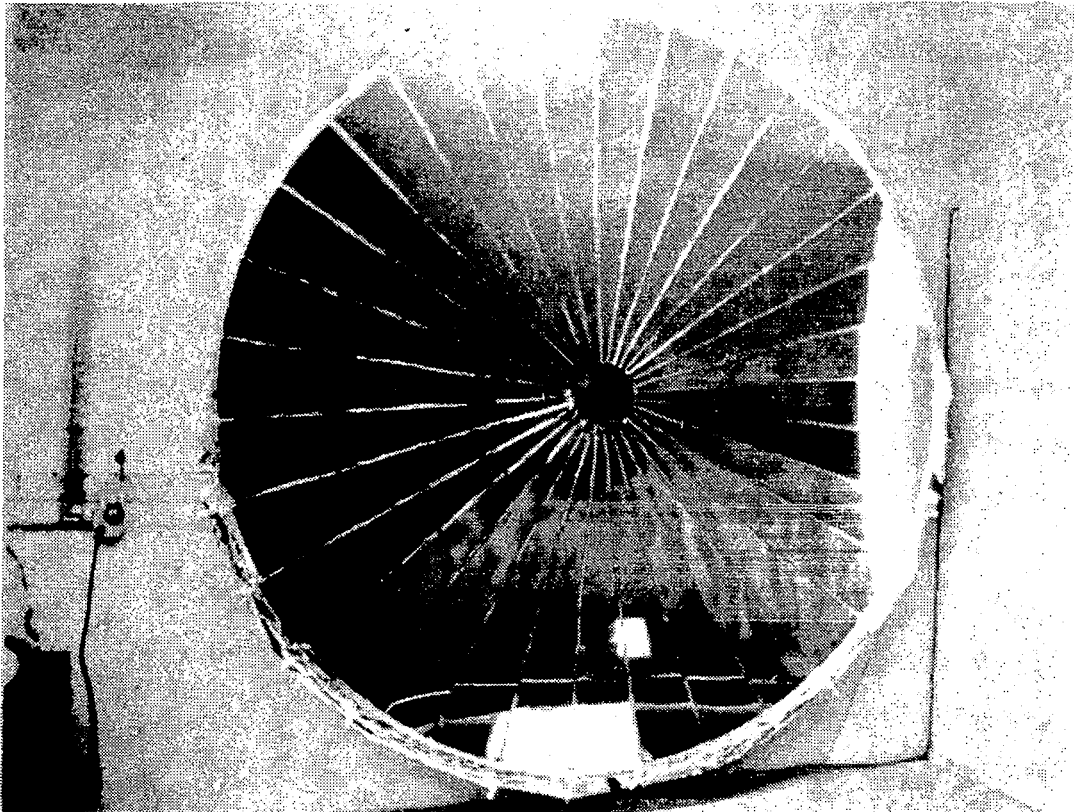

Figure 7

SELF-RIGIDIZING STRUCTURE

The composite was made by bonding aluminum foil to 0.013-mm polyester film (Fig. 8). The polyester provides tear resistance and a gas seal. Three different composites were made from three thicknesses of aluminum foil:

<u>Aluminum Thickness (mm)</u>	<u>Total Thickness (mm)</u>
0.050	0.113
0.076	0.139
0.102	0.156

The total adhesive thickness would be about 0.006 mm.

Structures such as cylinders and tori can be made from such composites and packaged. Gas pressure erects the structure and removes packaging wrinkles from the aluminum.

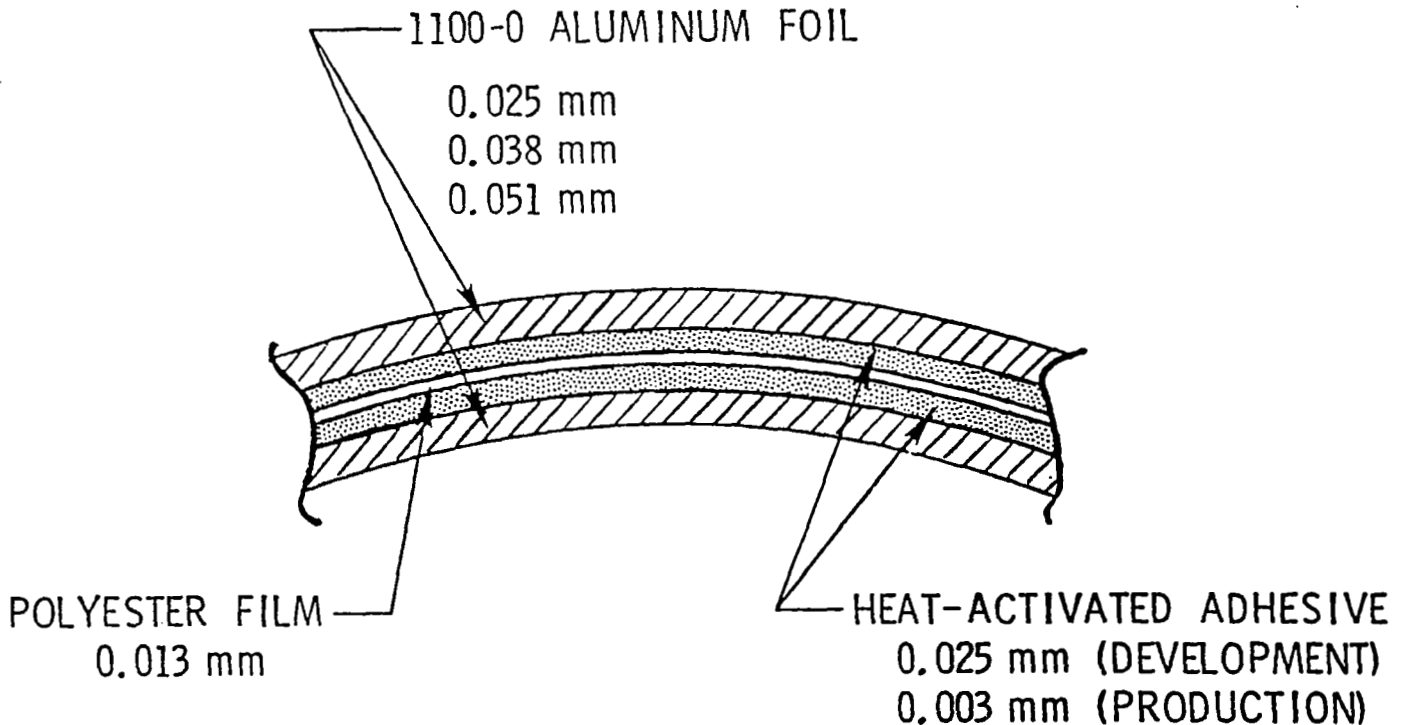

Figure 8

POST-PRESSURIZED TEST CYLINDERS

Figure 9 shows three test cylinders after pressurization and deflation. The cylinders have been pressurized such that the aluminum was stressed just above the proportional limit.

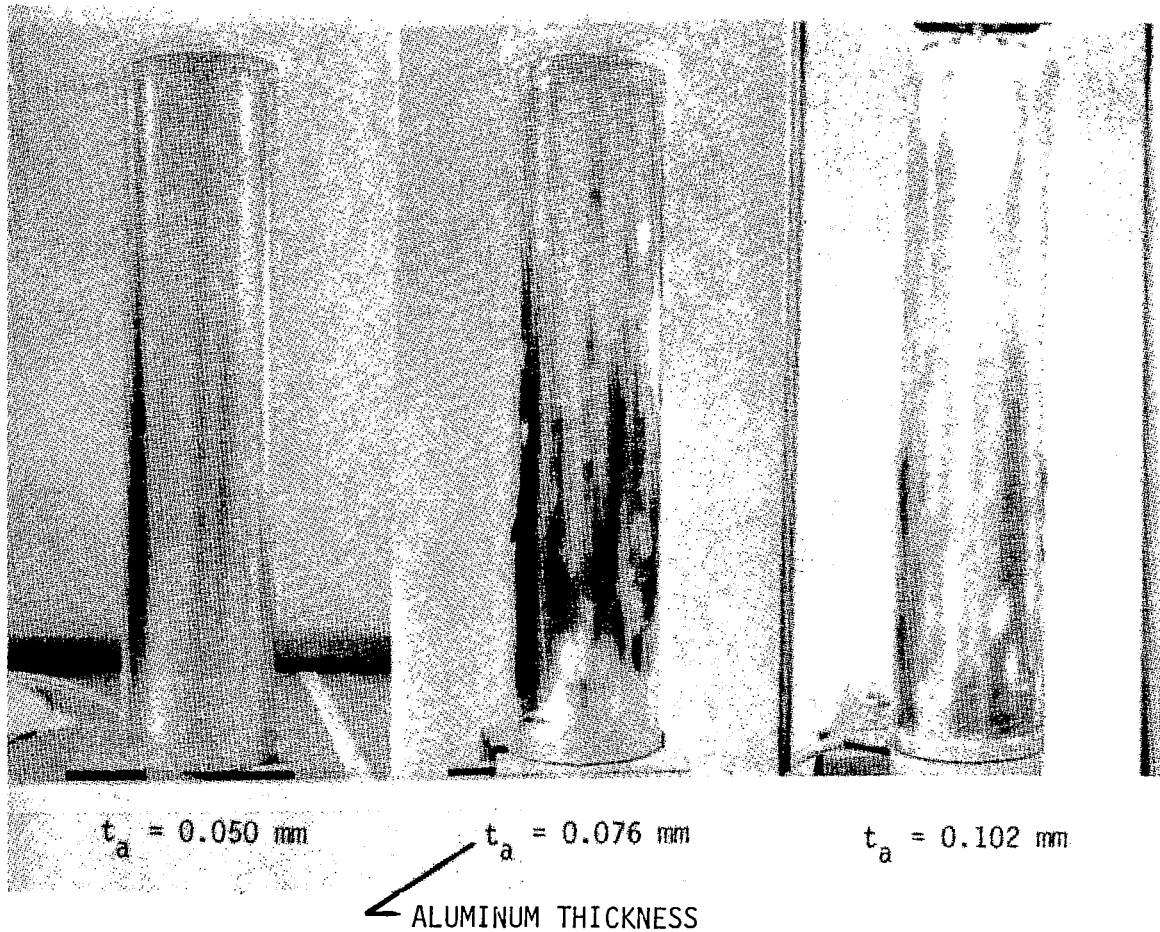

Figure 9

ANTENNA PACKAGE VOLUME

Package volume is shown in Figure 10 as a function of a diameter and f/D . Inflatables can be packaged more efficiently than mechanical systems. The high packaging density could be especially advantageous since it allows room for feeds, telemetry, attitude controls, and other subsystems, including perhaps an IUS. For this 16-meter-diameter flight experiment, the total package volume of the antenna structure would be approximately 0.028 cubic meters.

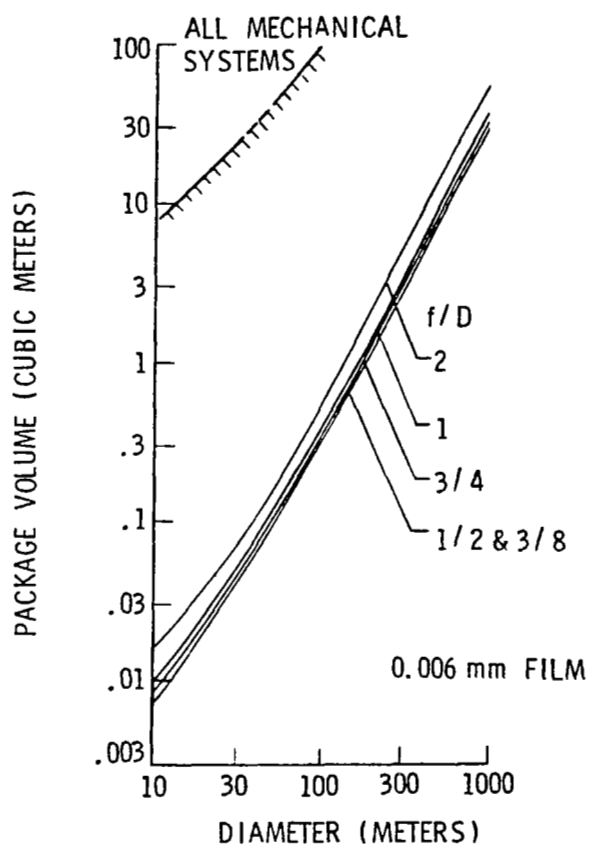

Figure 10

ANTENNA WEIGHT

The antenna total structure and inflation system weight is shown in Figure 11 as a function of diameter and f/D. Not included are the antenna feed, telemetry, attitude control, propulsion, and power supply, which are mission dependent. The weights are competitive with mechanical devices.

For typical missions, the structure weight ranges from 20 to 50 percent of the total spacecraft system weight. For this 16-m-diameter flight experiment, the structure is approximately 25 percent of the total system weight.

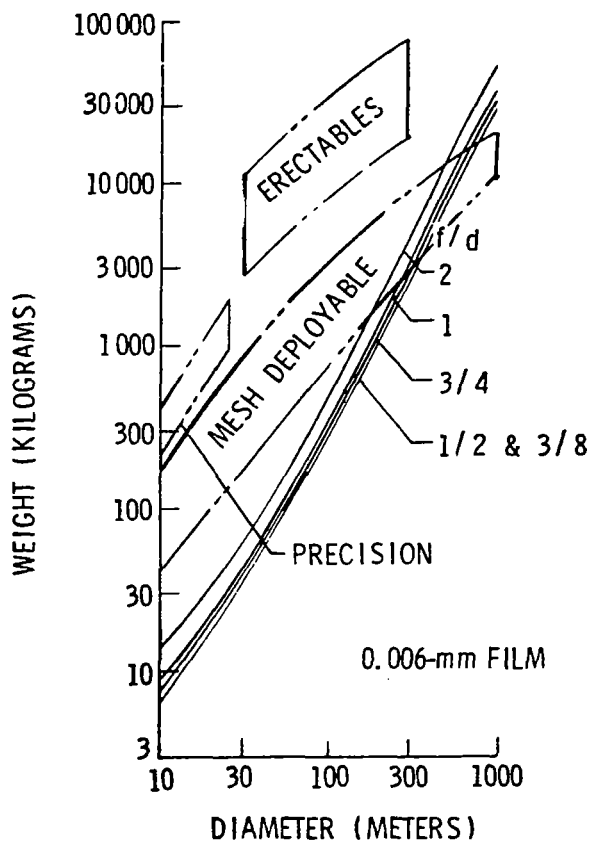

Figure 11

INFLATED-ANTENNA CHARACTERISTICS SUMMARY

Weight

Inflatable Structure	- 25 kg
RF Equipment at apex	- 45 kg
Support Subsystems	- 30 kg
Total	100 kg

Size

Packaged	1.5 m ³
Inflated, f/D=1	16 m

<u>Power</u> (average and peak)	0.1 kw
---------------------------------	--------

Instrumentation

Thermocouples - 32
Pressure sensors - 4
Transmitter/receiver
Optical system (with light emitting targets)

Data Requirements

5000 BPS real time and recorded
Photogrammetric photography
High-speed motion photography

Inflatants

Antenna	Water
Torus	Carbon dioxide

EXPERIMENT OPERATIONS

- Inflate antenna system - rigidizing the torus
- Measure temperature and pressures (inflation and maintenance)
- Measure surface accuracy by photogrammetry and feed alignment with optical system
- Verify electromagnetic performance (gain and pattern) using a ground station or geosynchronous target such as TDRSS (Shuttle points antenna (3° beam) toward target with accuracy of $\pm 0.5^\circ$).

SUMMARY

For inflatable antenna systems, technology feasibility can be demonstrated and parametric design and scalability (scale factor 10 to 20) can be validated with an experiment using a 16-m-diameter antenna attached to the Shuttle.

REFERENCES

1. Friese, G. J.; Thomas, M; and Hinson, W. F.: Inflated Antennas. Large Space Antenna System Technology - 1982, NASA CP-2269, Part 1, pp. 545-574, November 1982.
2. Friese, G. J; Bilyeu, G. D.; and Thomas, M.: Initial '80s Development of Inflated Antennas. NASA CR-166060, January 1983.

ADAPTIVE MICROWAVE REFLECTOR

J. W. Goslee
NASA Langley Research Center
Hampton, Virginia

ADAPTIVE MICROWAVE REFLECTOR EXPERIMENT

The current status of the electrostatic test fixture is that a flexible back electrode has been fabricated and tested with a preformed thin film (0.3-mil aluminized Kapton). Some of the problems that we have seen during ground testing are

- a. We have had trouble with the Kapton film because of its hygroscopic tendency under ground test conditions. We have tested an acrylic coating in hopes of decreasing the hygroscopic effect, but the test data does not show an appreciable decrease in water absorption.
- b. We have had trouble in the fabrication of 0.3-mil films in that the seam areas cannot be made wrinkle free. Wrinkles in the seam areas detract from the overall surface smoothness.

FLEXIBLE BACK ELECTRODE AND THEODOLITE MEASUREMENT SYSTEM

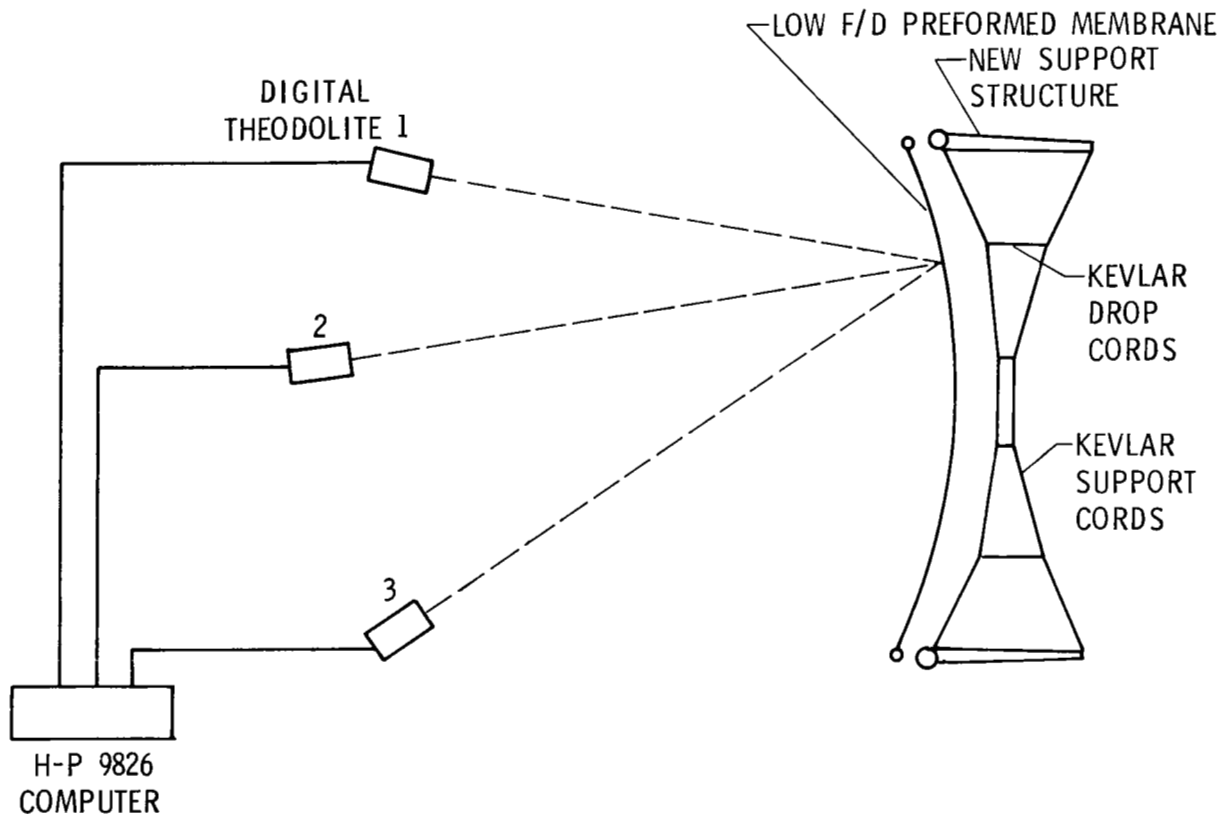

5-METER-DIAMETER ADAPTIVE MICROWAVE REFLECTOR

As an interim step in going to the 100-meter reflector that was evaluated by the Martin Marietta Company, a 5-meter reflector is proposed to test the electrostatic concept under space conditions. Some of the issues which require the space environment for evaluation are

1. Can deployment of a box ring structure with a thin film reflector attached be manually deployed?
2. In the absence of humidity, can a 0.3-mil aluminized Kapton film reflector be formed by the electrostatic process suitable for antenna applications?
3. Can the photogrammetric process be used to evaluate the reflector surface with pictures taken from the payload handling station?
4. Can the space charging effect be evaluated with the 5-meter reflector attached to the Shuttle?
5. Does the outgassing of moisture from 0.3-mil Kapton film affect its reflector capability?

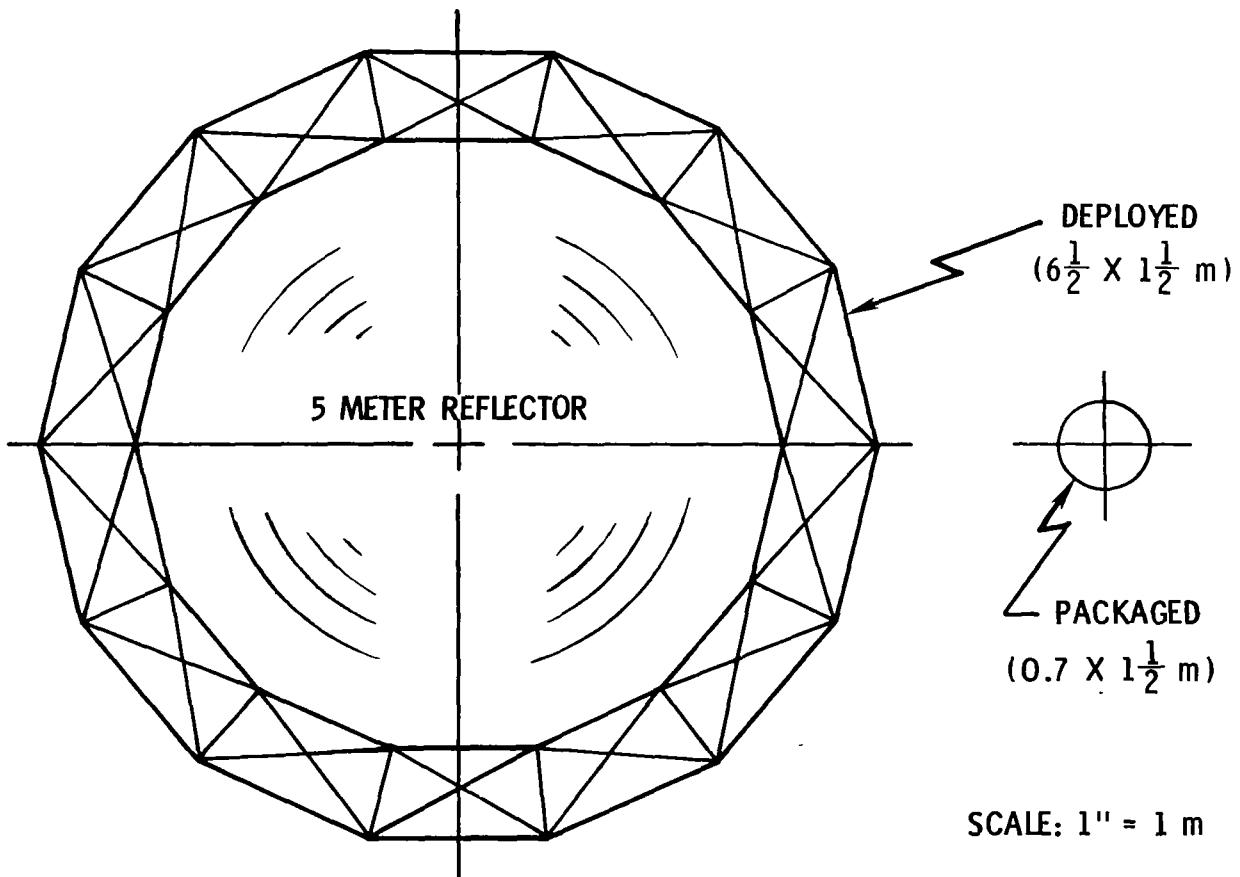

BOX RING TRUSS SUPPORT STRUCTURE

Even though several types of truss-type support structures can be used, the Martin Marietta box ring truss type is shown (based on the 100-meter design which is described in reference 1). It is proposed to deploy the reflector while it is attached to a pylon in the Shuttle bay. The dish will face forward so that the photogrammetric camera could be aimed from the window at the payload handling station and cover the whole reflector surface.

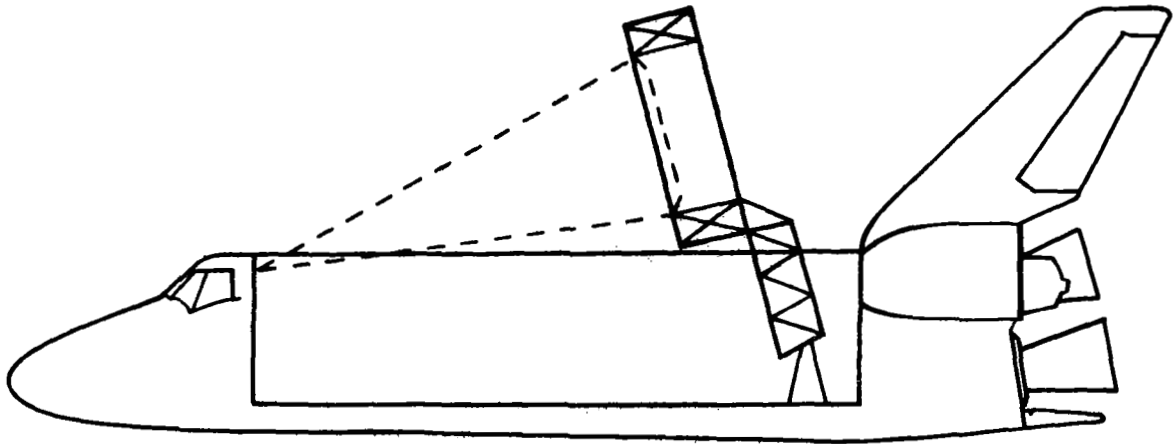

AUTOMATIC SEQUENTIAL DEPLOYMENT

Martin Marietta Company proposed an automatic sequential deployment for the 100-meter reflector. For the 5-meter experiment, it is proposed that the deployment sequence be simplified, and manual activation of the deployment steps be made.

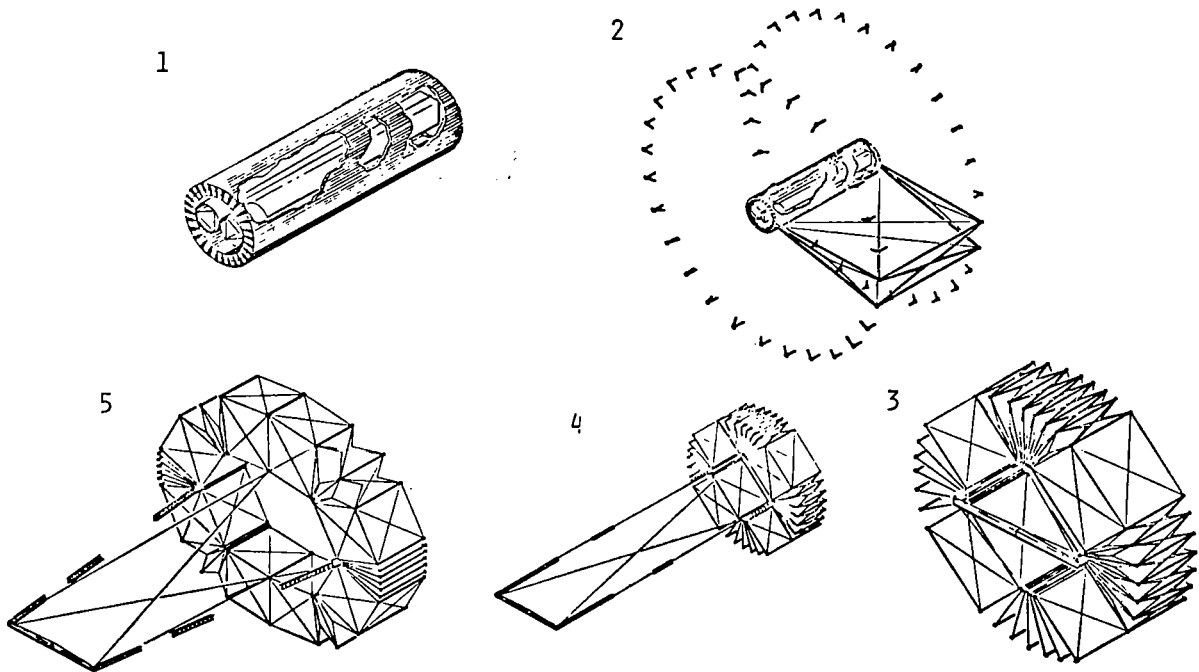

SUMMARY OF ESTIMATED REQUIREMENTS

Disposition of the experiment after a series of photogrammetric photographs were made would be to jettison the deployed reflector from the Shuttle. No effort is planned at this time to retract the reflector and return it to Earth. The figure below shows the estimated requirements for this experiment.

WEIGHT:	Reflector, Electrode, Structure	41 kg
	Power Supplies, Wiring	<u>14</u>
		55 kg (120 lbs)

ENVELOPE: 0.7 m X 1.5 m Packaged
6.5 m X 1.5 m Deployed

SUPPORT: 100 Watts Electrical Power (10 Power Supplies @ 10 Watts)
(24 V DC)
Photogrammetric Camera to be Available at Payload Handling
Station on Shuttle for Picture

REFLECTOR	}	.3 mil Aluminized Kapton 5 Meters in Diameter
BACK ELECTRODE		
FARADAY CAGE		

STRUCTURE: 14 Bays Made of Approximately 1-Inch Composite Tubes with
Provisions for Manual Deployment of Structure (.75 m Wide X 1.5 m Deep)

ESTIMATED COST:	45K X 14 Bays of Structure	\$ 650K
	(45K Per Bay Includes Design, Analysis, Fabrication, Quality Assurance, Acceptance Test)	
	Reflector, Back Electrode, Faraday Cage, Power Supplies and Support Pylon	<u>300</u>
		\$ 930K

REFERENCE

1. Brook, A. L.; Coyner, J. V.; Gardner, W. J.; and Mihora, D. J.:
Conceptual Design and Analysis of a Large Antenna Utilizing Electro-
static Membrane Management. NASA CR-3522, May 1982.

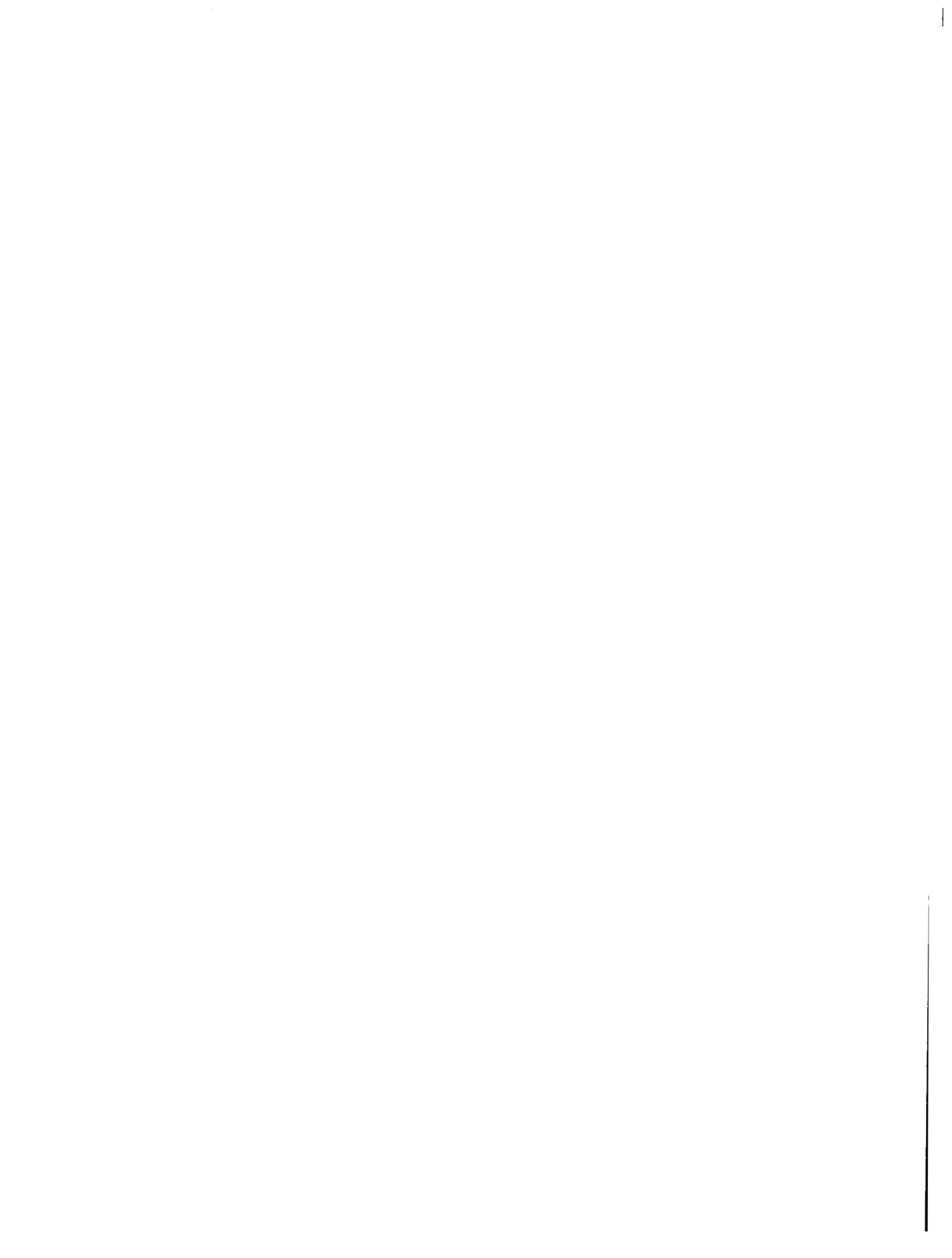

**MICROWAVE REFLECTOR CHARACTERIZATION
USING SIMPLE INSTRUMENTS IN EVA**

**J. W. Goslee
NASA Langley Research Center
Hampton, Virginia**

MICROWAVE REFLECTOR CHARACTERIZATION
USING SIMPLE INSTRUMENTS IN EVA

An antenna with rigid panels which can be measured under ground conditions, carried to space in a packaged condition, deployed into a form similar to the Earth-measured one, measured under space conditions, restowed, and brought back to Earth so that the original measurements can be verified is the type being proposed for this experiment. Several versions of this type of antenna have been developed. The California Institute of Technology has developed the type shown.

CALTECH CONCEPT FOR 7-PANEL
SELF-DEPLOYABLE RIGID ANTENNA

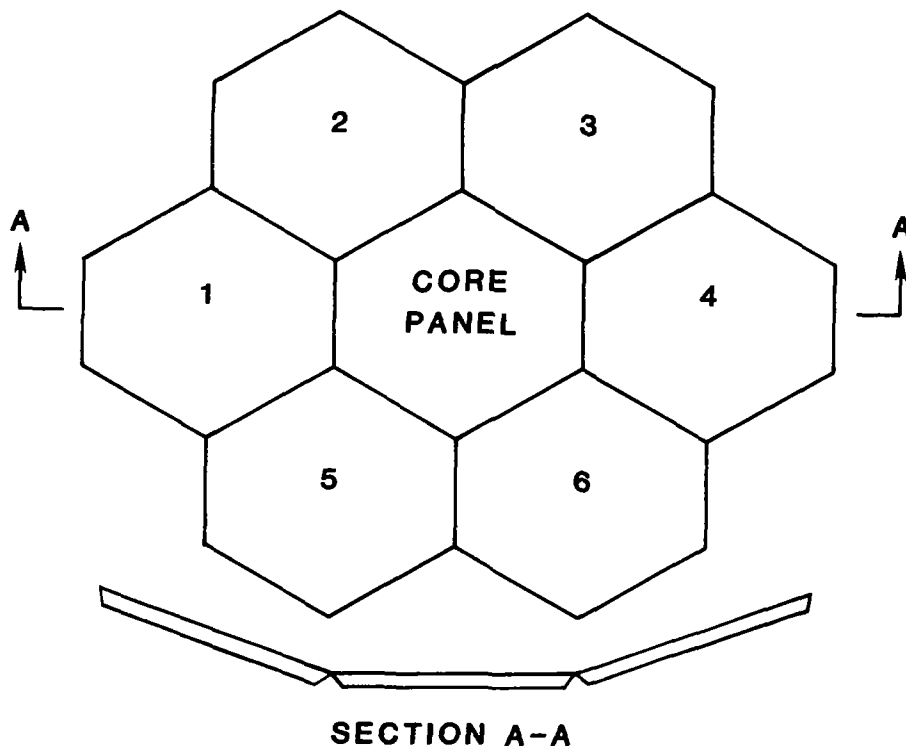

ANTENNA DEPLOYMENT

The antenna chosen will be measured under ground conditions, carried aloft, deployed into its antenna shape, lifted by the RMS to a position where it can be sighted by two astronauts in EVA at the two theodolites, and held there until the surface characterization can be completed. An alternate method would be to use photogrammetry and take pictures of the surface from the payload handling station. After the surface characterization is completed, the antenna will be folded and restowed into the Shuttle bay for return to Earth. The surface characterization will be repeated on Earth after its return for verification both of the original measurement taken on Earth and the measurement taken in space.

MANIPULATOR ARM REACH CAPABILITY

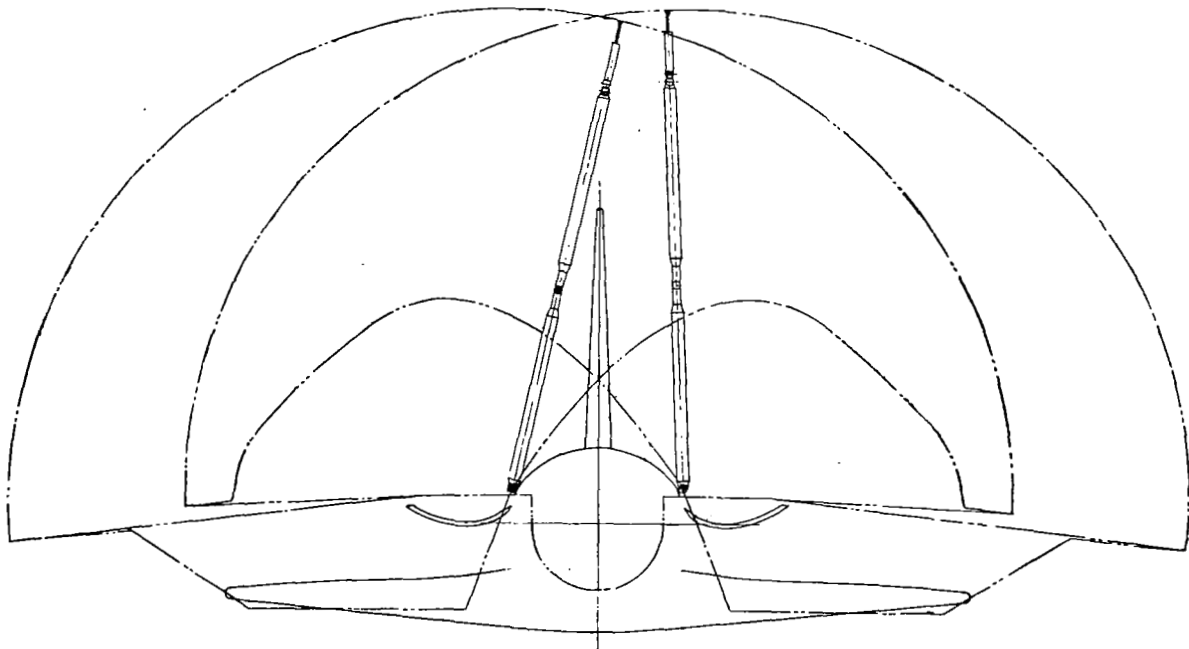

EVALUATION ISSUES

Some of the issues involved in this experiment which require the space environment for evaluation are

1. Can theodolites be used in an EVA mode to easily and practically measure a large antenna surface?
2. Can the RMS be used to hold an experiment long enough and steady enough to permit it to be measured?
3. Can an antenna measured on Earth be demonstrated to show that its surface when measured in space can be predicted and verified?
4. Which of the measurement systems, photogrammetry or theodolites, are more useful or practical in a space environment?

REFLECTOR CHARACTERIZATION WITH THEODOLITES

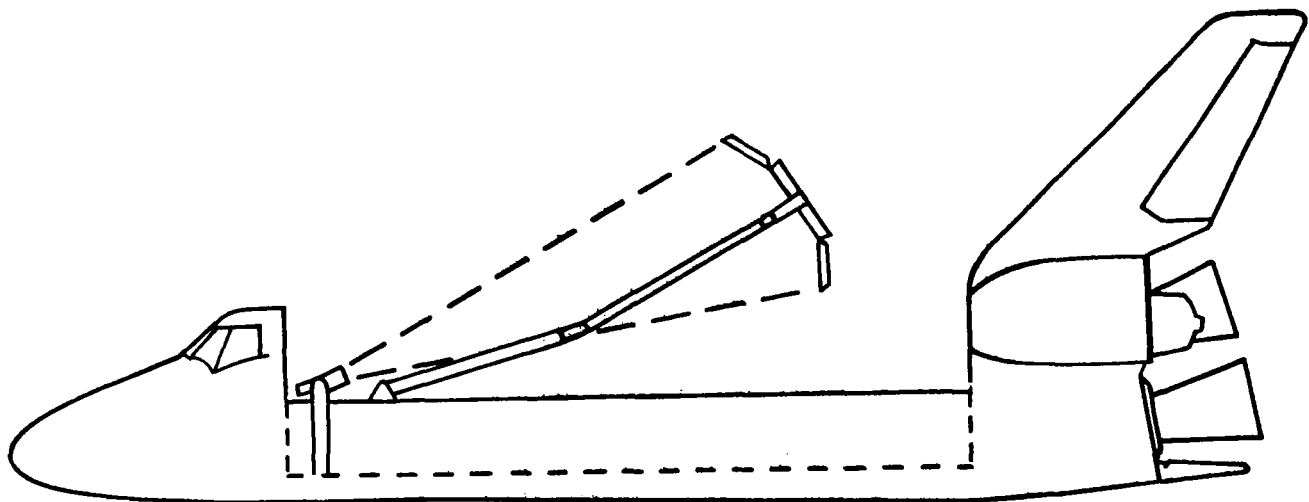

SUMMARY OF ESTIMATED REQUIREMENTS

Weight: Reflector 150 kg (330 lb)

Envelope: 4 feet by 3 feet by 10 inches Packaged
12 feet by 8 feet by 2 inches Deployed

Power: 100 W, 110 a.c., 60 Hz

Data Requirements: 300 baud rate
(Theodolite to computer)

FLIGHT TEST OF A SYNTHETIC APERTURE RADAR
ANTENNA USING STEP

D. G. Zimcik and F. R. Vigeron
Directorate of Space Mechanics
Communications Research Center
Department of Communications
Ottawa, Ontario, Canada

S. Ahmed
RADARSAT Technical Office
Communications Research Center
Department of Communications
Ottawa, Ontario, Canada

RADARSAT PROGRAM

The primary function of the RADARSAT system is to provide daily ice information from the Beaufort Sea, Northwest Passage, Baffin Bay, and the Davis Strait on an all-weather basis to assist in energy and other resource-related operations. A secondary function includes the provision of information on oceans and land masses (renewable and nonrenewable resources). The system comprises four elements, namely a low polar-orbiting spacecraft, a ground-based data processing system, a mission control facility, and a communications system. The main spacecraft payload is a synthetic aperture radar (SAR). The current plans aim for a RADARSAT spacecraft launch in 1990.

The RADARSAT mission is presently designed for a circular, Sun-synchronous, low (1000 km), polar (99.5° inclination) orbit with a descending node crossing at 0944 hours local mean time. The orbital period is about 105 minutes with a 35-minute eclipse. One of the mission-critical components of the SAR system is the radar antenna designed to operate at a frequency of 5.3 GHz. The RADARSAT SAR antenna is Earth oriented with its longer dimension along the velocity vector. To obtain the desired gain and Earth footprint requires an antenna size on the order of 14 m by 2 m. The antenna must also have a low mass and be stowed in a compact manner for the launch. This figure indicates the RADARSAT mission concept.

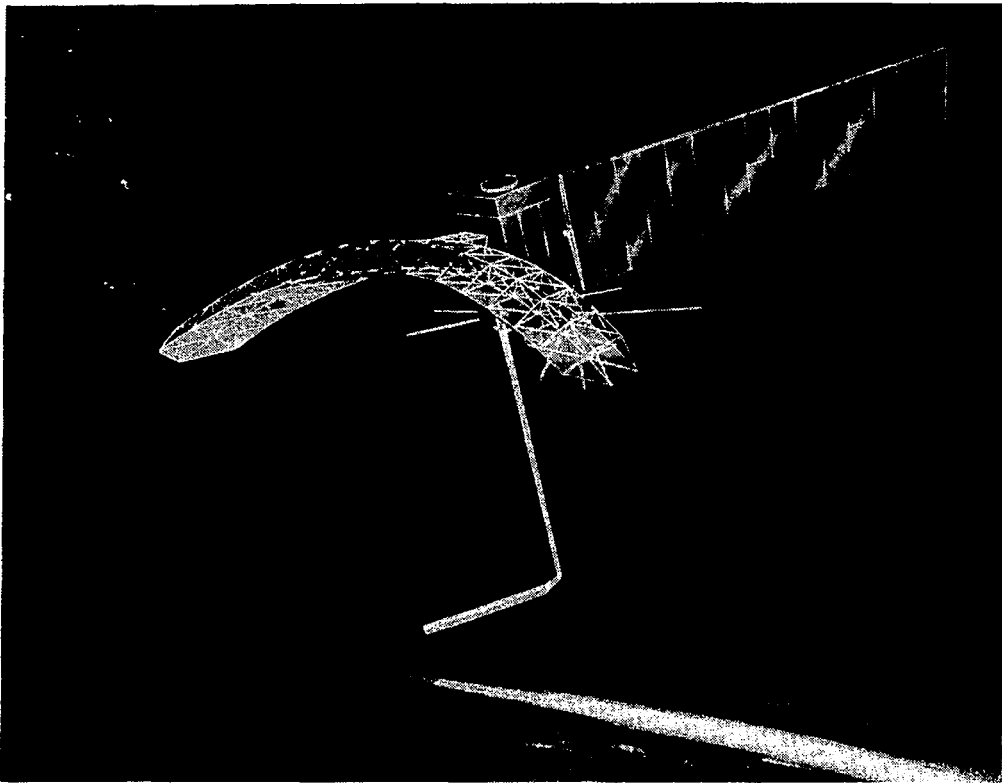

SAR ANTENNA ON STEP

To establish confidence in its overall performance, credible information on the antenna's mechanical properties in orbit must be obtained. However, the antenna's size, design, and operating environment make it difficult to simulate operating conditions under 1-g Earth conditions.

The Space Technology Experiments Platform (STEP) offers a timely opportunity to mechanically qualify and characterize the antenna design in a representative environment. The proposed experimental configuration would employ a half-system of the full-scale RADARSAT antenna which would be mounted on the STEP platform in the orbiter cargo bay such that it could be deployed and retracted in orbit (as shown in this figure). The antenna would be subjected to "typical" environmental exposures while an array of targets and sensors on the antenna support structure and reflecting surface are observed and monitored. In particular, the typical environments would include deployment and retraction, dynamic response to vehicle thruster or base exciter inputs, and thermal soak and transient effects upon entering or exiting Earth eclipse. The proposed experiment would also provide generic information on the properties of large space structures in space and on techniques to obtain the desired information.

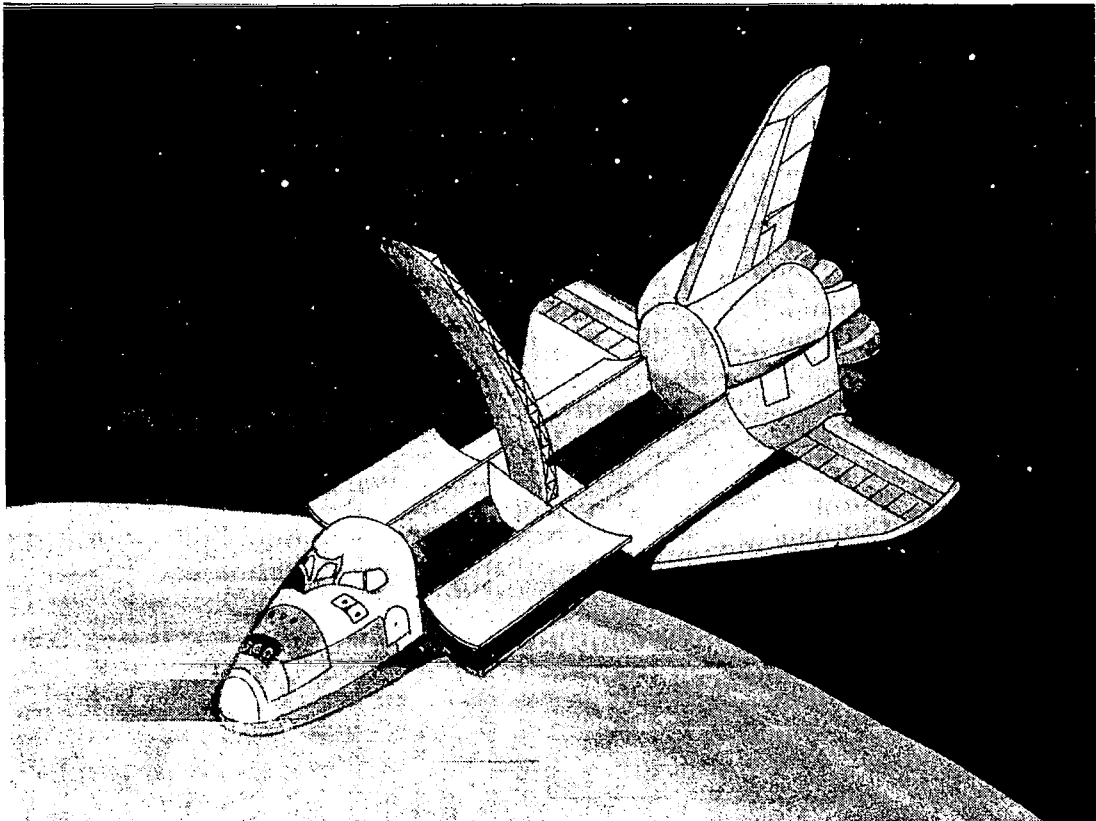

GOALS OF THE EXPERIMENT

The specific antenna performance information and properties that are intended to be obtained are

- i) Deployment and retraction performance of the antenna structure
- ii) Surface accuracy of the reflector (or radiating) antenna surface, and the thermoelastic response of the antenna structure
- iii) Structural dynamics properties of the antenna
- iv) Properties and behavior of the materials employed

Each of these is discussed in more detail in subsequent sections of this paper.

● TEST AND OBSERVE DEPLOYMENT AND STRUCTURAL BEHAVIOR OF A PROTO-SYNTHETIC APERTURE RADAR (SAR) REFLECTOR ANTENNA

- DEPLOYMENT/ RETRACTION
- SURFACE ACCURACY
- THERMOELASTIC RESPONSE
- STRUCTURAL DYNAMICS
- MATERIALS BEHAVIOR

DEPLOYMENT AND RETRACTION PERFORMANCE

The antenna may be either a reflector or a planar array. Either type will be stowed for launch and will be deployed (retracted) or assembled (disassembled) in the Shuttle bay. Associated with both approaches are a number of mechanisms that must work in a predetermined sequence and must be confirmed after each operation.

In the case of deployment, the stowed antenna hold-down latches must release, and the antenna, depending on the design, must be deployed bay by bay or simultaneously as one unit. The various joints must lock into place to give the desired rigidity and antenna shape. During retraction, the procedure is reversed with the final antenna hold-down latch (or latches) restowing the antenna for a safe reentry and landing of the Shuttle.

In the case of an assembled type of antenna, the latches holding down the antenna sub-panels must be released followed by a sequenced assembly using the Remote Manipulator System (RMS). There must be definitive information conveyed that the RMS has rigidly snared the sub-panel, and after assembly, the mating mechanisms between sub-panels have locked into place as per the design. During disassembly, the operation is reversed until the antenna sub-panel package is restowed safely in the Shuttle bay.

Use of the Shuttle-based closed circuit television (CCTV) system is proposed to monitor the deployment/retraction sequence. This would involve fixed locations such as the Shuttle cargo-bay forward bulkhead and possibly a movable mount on the RMS system. The visual monitoring would be supplemented by microswitches to indicate the latching (delatching) of mechanisms. In addition, the accelerations and structural stresses during deployment would be monitored by strategically located strain gages and accelerometers.

- ANTENNA LIKELY TO BE DEPLOYED/RETRACTED BAY BY BAY OVER A 30-MINUTE TIME PERIOD TO OBSERVE/TEST KINEMATICS OF DEPLOYMENT AND OPERATION OF MECHANISM
- PRINCIPAL IN-ORBIT MEASUREMENTS:
 - CCTV CAMERA MOUNTED ON FORWARD BULKHEAD OR STEP PLATFORM
 - MICROSWITCHES ON ANTENNA
 - ACCELEROMETERS AND STRAIN GAGES

SURFACE ACCURACY AND THERMOELASTIC RESPONSE OF THE ANTENNA STRUCTURE

Surface inaccuracies in the antenna can occur from both fabrication tolerances and deformations due to the thermal environment of space. These inaccuracies result in loss of antenna gain and in the broadening of the main beam (the magnitude of which depends on the operational frequency). In a SAR antenna, the latter occurrence contributes to range and azimuth ambiguities resulting in degradation in the SAR image quality. If the behavior of the surface is quantified, the problem of ambiguities on the image quality can be diminished in the design of the SAR system.

Thermoelastic deformations of the overall antenna structure are caused by the temperature field induced by the orbital environment. This may contribute to surface inaccuracies or change the effective orientation of the antenna beam. Continuous knowledge of the effective orientation is essential to enable the SAR image to be appropriately geo-referenced during the processing of the SAR data.

It is intended to characterize the surface inaccuracies and thermoelastic response of the antenna. The proposed technique is to use a surface-deflection measurement system (possibly a photogrammetric technique using the Shuttle-based CCTV) and strategically located temperature sensors, strain gages, and accelerometers.

- RADARSAT MISSION REPRESENTATIVE THERMOELASTIC RESPONSE OF THE STRUCTURE TO BE EVALUATED BY ORIENTING THE REFLECTOR OR STEP (SHUTTLE) RELATIVE TO THE SUN AND EARTH TO IDENTIFY EFFECT ON REFLECTOR SURFACE ACCURACY
- PRINCIPLE IN-ORBIT MEASUREMENTS:
 - SURFACE DEFLECTION MEASUREMENT SYSTEM (POSSIBLY PHOTOGRAMMETRY BASED)
 - TEMPERATURE SENSORS
 - STRAIN GAGES, ACCELEROMETER, ETC.

STRUCTURAL DYNAMICS

The resolution requirements of the SAR system must be achieved with the spacecraft RCS system operational. The dynamic physical displacements of the very large appendages in response to orbital inputs may degrade antenna performance. Also, the measurement of structural dynamics of the antenna is needed to verify flexible-body-dynamics-related parameters associated with the control system design of the RADARSAT spacecraft and to confirm that the antenna shape is static and stable (for example, to confirm that thermal flutter or similar unexpected phenomena are not occurring).

The modal frequencies, damping factors, and shape coefficients will be identified experimentally. A dynamic test input will be introduced by controlled RCS-induced Shuttle maneuvers if feasible, or with a specially designed unidirectional translational base exciter. The input signal will be measured via RCS pulse counters and Shuttle attitude instruments (such as gyros). If a base exciter is used, the input would be measured with a base-mounted accelerometer. Measurements of structural response will be made with accelerometers and possibly strain gages and force transducers. These input and response measurements will be telemetered to Earth for off-line processing with modal parameter identification software. Comparisons of measured modal parameters with prior analytical predictions will be made to validate the antenna structural dynamics design software.

- PARAMETER IDENTIFICATION OF MODAL PARAMETERS THROUGH GROUND-BASED ANALYSIS OF STRUCTURAL RESPONSE MEASUREMENT OF DYNAMIC TEST INPUT FROM CONTROLLED RCS-INDUCED SHUTTLE MANEUVERS, OR WITH A SPECIALLY DESIGNED BASE EXCITER

- PRINCIPAL IN-ORBIT MEASUREMENTS
 - ACCELEROMETERS
 - POSSIBLY STRAIN GAGES AND/OR FORCE TRANSDUCERS
 - SHUTTLE PULSE COUNTERS/GYROS (TBD) OR BASE-EXCITER MOUNTED ACCELEROMETERS

MATERIALS BEHAVIOR

Requirements for surface contour accuracy (on the order of millimeters for C-band radar) and pointing accuracy (on the order of a tenth of a degree), the 5-year mission life, and a minimum mass structure dictate the use of advanced composite materials for the antenna. Knowledge of environmental resistance is important since polymer matrix composite materials are susceptible to the effects of vacuum, thermal cycling, space radiation, and material creep. In addition, there are manufacturing tolerances that cause the "as-built" structure to differ from the "as-designed" structure.

Although the STEP exposure will be short, it is anticipated that several thermal cycles will be experienced in addition to the vacuum environment. Fortunately, Earth-based testing has indicated that most of the variation in the coefficient of thermal expansion (CTE) which might occur will be exhibited within the first few cycles. Also, structural integrity after launch vibration will be verified (including mesh management), although it is recognized that this environment may differ somewhat from the RADARSAT launch configuration. Finally, the issue of joint lubrication and/or freedom can be assessed during deployment.

- SPACE ENVIRONMENT EXPOSURE OF ADVANCED COMPOSITE MATERIALS SUSCEPTIBLE TO EFFECTS OF VACUUM, THERMAL CYCLING AND SPACE RADIATION TO BE EVALUATED THROUGH EXPOSURE TO EVALUATE EFFECTS ON CTE, STIFFNESS, ETC.
- STRUCTURAL INTEGRITY AND MESH MANAGEMENT VERIFIED IN LAUNCH CONFIGURATION
- PRINCIPAL IN-ORBIT MEASUREMENTS
 - TEMPERATURE SENSORS AND STRAIN GAGES
 - CCTV

MISSION SCENARIO

It is envisioned that the experiment will be conducted during a sequence of orbits which have eclipse conditions. In preparation for operation, the Shuttle will acquire an appropriate attitude relative to the Sun and Earth. The antenna will then deploy in sequenced stages under observation using a CCTV camera, and instruments will be checked out during a first orbit. During a second orbit, surface accuracy and associated thermal measurements will be made during a face-on-Sun thermally stabilized constant Sun condition and during eclipse and transitions. The Shuttle attitude will then be changed to provide different antenna orientations to the Sun, and surface accuracy measurements will be made throughout the third and fourth orbit. During a fifth orbit, structural vibration will be excited and measured with Shuttle maneuvers or a base exciter. The Shuttle will then be maneuvered to allow the Sun vector to traverse the back of the antenna during the sixth orbit in a fashion representative of actual RADARSAT conditions, and surface accuracy measurements will be made. The antenna will be restowed under observation by the CCTV camera during the final orbit.

- ACQUIRE SHUTTLE ORBIT
- DEPLOY ANTENNA SEQUENTIALLY WHILE OBSERVING WITH CCTV (ORBIT 1)
- CHECK INSTRUMENTATION FUNCTION
- STABILIZE ANTENNA THERMALLY UNDER CONSTANT SUN LOAD (ORBIT 2)
- MEASURE SURFACE ACCURACY PRIOR TO ECLIPSE
- STABILIZE ANTENNA THERMALLY UNDER DIFFERENT CONSTANT SUN LOAD (ORBIT 3)
- MEASURE SURFACE ACCURACY PRIOR TO ECLIPSE
- STABILIZE ANTENNA THERMALLY UNDER DIFFERENT CONSTANT SUN LOAD (ORBIT 4)
- MEASURE SURFACE ACCURACY PRIOR TO ECLIPSE
- EXCITE AND MEASURE STRUCTURAL VIBRATION WITH SHUTTLE MANEUVERS OR BASE EXCITER (ORBIT 5)
- TRAVERSE ANTENNA BACK WITH SUN VECTOR WITH PERIODIC SURFACE ACCURACY MEASUREMENT (ORBIT 6)
- RESTOW ANTENNA SEQUENTIALLY WHILE OBSERVING WITH CCTV (ORBIT 7)

SCHEDULE

As noted earlier, RADARSAT is scheduled for launch in 1990. Although the detailed schedule for the program subsystems to meet the projected launch has yet to be finalized, the following figure shows the anticipated SAR antenna activity schedule. The SAR schedule is compared to the STEP flight schedule as shown in the figure below.

Recognizing the intent to use the STEP flight test as part of the RADARSAT qualification test program using flight configuration hardware, the important dates to compare are the starting date to build qualification hardware, the starting date to build flight hardware, and the STEP launch dates. As a result, there is a rather narrow period between flights 2 and 3 that would benefit RADARSAT. Earlier flights might precede qualification hardware availability, and later flights might preclude design changes resulting from observed antenna responses. Consequently, an early flight is crucial to satisfy the needs of the RADARSAT schedule.

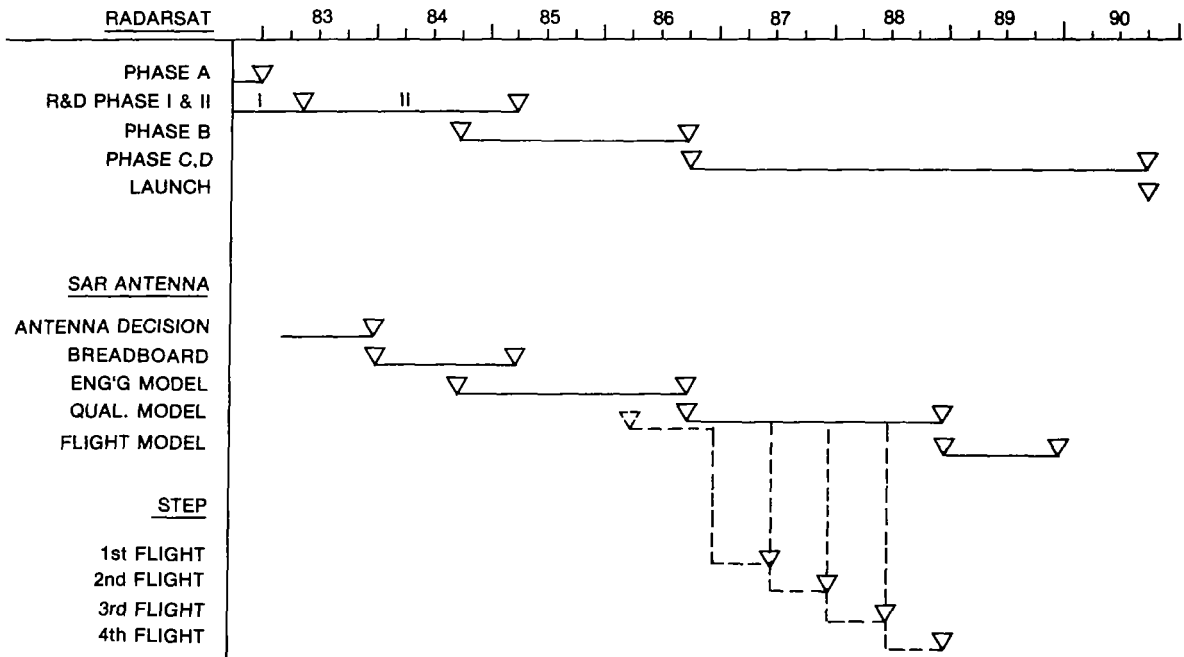

CONCLUSIONS

STEP offers a potentially attractive in-orbit qualification and test facility for the RADARSAT SAR antenna. The indicated schedule of STEP is compatible with that of RADARSAT.

The proposed experiment is at the preliminary idea stage, and many of the details offered regarding support requirements are educated estimates at this point. The information may change as technical progress is made in STEP and the RADARSAT antenna design and as a better understanding of the economics of using STEP is realized.

- STEP COULD BE A UNIQUE TEST FACILITY FOR RADARSAT SAR ANTENNA
- TIMING OF STEP COMPATIBLE WITH RADARSAT QUALIFICATION SCHEDULE
- MANY ISSUES OUTSTANDING

APPENDIX

PHYSICAL REQUIREMENTS

The experimental antenna hardware would comprise one-half of a full-scale (14 m × 2 m) RADARSAT Synthetic Aperture Radar antenna reflector and its support structure. This would include mechanisms for on-orbit deployment and retraction which may be semiautomatic. The size of the stowed antenna is estimated at 2½ m × ½ m × ½ m with a mass of approximately 100 kg. It will be oriented with the major dimension across the cargo-bay width. When deployed, the reflector would extend to a height of approximately 10 m out of the cargo bay, by a width of 2 m across the cargo bay. The reflector curvature will result in a forward movement of the reflector tip of 3 m after deployment. Initial estimates indicate a preferred location in the cargo bay of approximately 4 m back from the forward bulkhead to facilitate the best camera angles.

The indicated measurement instrumentation is estimated to require 2 boxes of .05 m³ volume located in a convenient but close position on STEP. Mass is estimated at 50 kg for a total requirement of 150 kg. Data recording, power, telemetry, and command are assumed to be part of STEP.

WEIGHT

- 150 KG TOTAL
- 100 KG ALLOTTED FOR ANTENNA REFLECTOR
- 50 KG ALLOTTED FOR INSTRUMENTATION AND ELECTRONICS
- DATA RECORDING, POWER CONDITIONING ASSUMED TO BE PART OF STEP

STOWED CONFIGURATION

- ANTENNA REFLECTOR — 2.5 M x 0.5 M x 0.5M
— MAJOR DIM. ACROSS CARGO BAY WIDTH
- MEASUREMENT ELECTRONICS — 2 0.05M³ BOXES LOCATED IN A CONVENIENT CLOSE POSITION

DEPLOYED CONFIGURATION

- 10 M (OUT OF CARGO BAY) x 2 M (CARGO BAY WIDTH) x 3 M AT TIP (SHUTTLE VELOCITY DIRECTION)
- PREFERRED LOCATION IN CARGO BAY - 4 M BACK FROM FORWARD BULKHEAD

SUPPORT REQUIREMENTS

Shuttle-Based Equipment

A CCTV camera mounted on the forward Shuttle bulkhead or STEP platform is required. A second CCTV camera is desirable.

The RMS may be required for an erectable antenna concept and could be desirable for stowage of the deployable antenna or as a camera mount.

In order to provide a test bed for structural dynamics experiments, an excitation source might be considered as a standard component of STEP. This exciter could be a low-frequency uniaxial translational base exciter of relatively low force capability.

Power Requirements

Power requirements are not yet known. Power is needed for deployment and retraction, the deflection sensing system, accelerometers, load cells, temperature sensors, and possibly a base excitation system. It is assumed that power for telemetry command and the CCTV's is provided as part of the STEP facility or the Shuttle.

SHUTTLE BASED EQUIPMENT

- CCTV ON FORWARD SHUTTLE BULKHEAD OR STEP PLATFORM
- RMS MAY NOT BE NECESSARY BUT DESIRABLE
- ALTERNATE CCTV MAY BE ADVANTAGEOUS

POWER REQUIREMENTS

- POWER REQUIREMENTS HAVE NOT YET BEEN DEFINED
- WILL DEPEND ON MEASUREMENTS AND EXCITATION SYSTEMS CHOSEN
- POWER CONSUMPTION LIKELY TO INCLUDE:
 - 2 CCTV
 - LIGHT SOURCE
 - DATA RECORDING
 - DEPLOYMENT AND RETRACTION
 - MECHANICAL EXCITATION

SUPPORT REQUIREMENTS (Continued)

Data and Telemetry Requirements

Data sources directly from the antenna package includes

- antenna microswitches (about 30 flag channels)
- surface deflection measurement system
- accelerometers, load cells, strain gages (about 20 analog channels)
- temperature sensors (about 20 analog channels)
- possibly a base exciter (about two analog channels)

Also, the following data is needed

- CCTV(s)
- Shuttle ephemeris and attitude data

Required sample rates are not yet known. Recording and time tagging of all data are required. A subset of the data (not yet defined) must also be transmitted for real-time operations.

DATA REQUIREMENTS

- REQUIRED DATA CHANNEL ALLOCATION AND SAMPLE RATES ARE NOT YET KNOWN
- ● DATA SOURCES MAY INCLUDE
 - ANTENNA MICROSWITCHES (30 FLAG CHANNELS)
 - CCTV (2 CHANNELS)
 - SURFACE DEFLECTION MEASUREMENT SYSTEM (POSSIBLY PHOTOGRAMMETRY BASED)
 - ACCELEROMETERS, STRAIN GAGES, ETC. (20 ANALOG CHANNELS)
 - MECHANICAL EXCITER (POSSIBLY 2 ANALOG CHANNELS)
 - TEMPERATURE SENSORS (30)
 - SHUTTLE EPHEMERIS DATA
- IT IS ASSUMED THAT A DATA SUBSET MUST BE TRANSMITTED BY TELEMETRY IN REAL TIME
- ON-BOARD RECORDING OF ALL SIGNALS WILL BE REQUIRED

SUPPORT REQUIREMENTS (Concluded)

Experiment Commands

Antenna deploy/retract	-	5 bilevel commands
Jettison		
Deflection measurement system, accelerometers, load cells, strain gages, temperature sensors	}	1 bilevel command each
Base exciter	-	4 value commands
Others (possibly heaters)	-	2 bilevel commands
CCTV control of pan and tilt	-	assumed part of Shuttle command system

EXPERIMENT COMMANDS

- ANTENNA DEPLOY/RETRACT —5 BILEVEL COMMANDS
- JETTISON
- DEFLECTION MEASUREMENT SYSTEM
- ACCELEROMETERS
- STRAIN GAGE/LOAD CELL
- BASE EXCITER - 4 VALUE COMMANDS
- CCTV CONTROL - PART OF SHUTTLE COMMAND SYSTEM (?)
- OTHERS (?) - HEATERS, ETC.

MISSION REQUIREMENTS

The RADARSAT mission is presently designed for a circular, Sun-synchronous, low (1000 km), polar (99.5° inclination) orbit with a descending node crossing at 0944 hours local mean time. The orbital period is about 105 minutes with a 35-minute eclipse. The RADARSAT SAR antenna is Earth-oriented with its longer dimension (14 m) along the velocity vector.

Ideally, this mission profile should be simulated in the STEP mission. However, from Shuttle-related practical considerations, it is recognized that compromises have to be made. It is felt that the "standard" 28° orbit could be acceptable if Shuttle orientation could be controlled during the experiment. Also, altitude and eccentricity are not seen as critical since the test duration is too short to evaluate radiation effects on materials. As noted, attitude pointing stability is a critical parameter in order to achieve the proper Sun vector orientations to irradiate the front, back, or side of the antenna in a steady-state or transient fashion as required. These exact conditions have not yet been finalized, and there remains an opportunity to optimize with respect to other Shuttle payload items.

It is estimated that the experiment could take up to 8 Shuttle orbits (preferably consecutive) to gather the required data.

ALTITUDE

- NOT SEEN AS CRITICAL

INCLINATION

- POLAR PREFERRED (99.5°)
- STANDARD 28° ORBIT ACCEPTABLE IF SHUTTLE ORIENTATION CONTROLLED

ECCENTRICITY

- NOT CRITICAL

DURATION

- UP TO 8 (PREFERABLY CONSECUTIVE) ORBITS OF ACTIVE EXPERIMENTATION

ATTITUDE POINTING AND STABILIZATION

- CRITICAL
- SUN ANGLES TO PROVIDE (AS EXAMPLES)
 - SUN ON BACK OF ANTENNA
 - SUN ON SIDE OF ANTENNA
 - SUN VECTOR TRANSVERSING BACK OF ANTENNA DURING ORBIT
- EXACT CONDITIONS ARE NOT YET DETERMINED
- MAY VARY WITH SHUTTLE LOAD

1. Report No. NASA CP-2294		2. Government Accession No.		3. Recipient's Catalog No.	
4. Title and Subtitle STEP EXPERIMENT REQUIREMENTS				5. Report Date January 1984	
				6. Performing Organization Code 506-62-43-91	
7. Author(s) M. Larry Brumfield, Compiler				8. Performing Organization Report No. L-15733	
				10. Work Unit No.	
9. Performing Organization Name and Address NASA Langley Research Center Hampton, Virginia 23665				11. Contract or Grant No.	
				13. Type of Report and Period Covered Conference Publication	
12. Sponsoring Agency Name and Address National Aeronautics and Space Administration Washington, DC 20546				14. Sponsoring Agency Code	
15. Supplementary Notes					
16. Abstract This document is compiled from presentations at the STEP Experiment Requirements Workshop held at NASA Langley Research Center, Hampton, Virginia, June 28-July 1, 1983. NASA personnel reviewed the preliminary design of the Space Technology Experiments Platform (STEP). Experiment proposers previewed their experiment concepts and expected requirements for support services. This document contains most of the visual material presented by participants, together with as much descriptive material as was provided to the compiler.					
17. Key Words (Suggested by Author(s)) Structures, materials, and analyses Structural dynamics Large space systems Structural technology flight experiments Control dynamics			18. Distribution Statement Unclassified - Unlimited Subject Category 15		
19. Security Classif. (of this report) Unclassified	20. Security Classif. (of this page) Unclassified	21. No. of Pages 361	22. Price* A16		

* For sale by the National Technical Information Service, Springfield, Virginia 22161

★ U.S. GOVERNMENT PRINTING OFFICE: 1984-739-010 50 REGION NO 4

National Aeronautics and
Space Administration

Washington, D.C.
20546

Official Business
Penalty for Private Use, \$300

SPECIAL FOURTH CLASS MAIL
BOOK

Postage and Fees Paid
National Aeronautics and
Space Administration
NASA-451



NASA

POSTMASTER: If Undeliverable (Section 158
Postal Manual) Do Not Return
