

INTERACTIVE COMPUTER MODELING OF COMBUSTION CHEMISTRY
and
COALESCENCE-DISPERSION MODELING OF TURBULENT COMBUSTION

David T. Pratt
University of Washington

The goals of this research project are as follows:

1. Develop an interactive computer code for simulation of a high-intensity turbulent combustor as a "single point" inhomogeneous stirred reactor [1]. This will be developed from an existing batch processing computer code CDPSR [2].
2. Use the interactive CDPSR code as a guide for interpretation and direction of DOE-sponsored companion experiments utilizing Xenon tracer with optical laser diagnostic techniques to experimentally determine the appropriate mixing frequency, and for validation of CDPSR as a mixing-chemistry model for a laboratory jet-stirred reactor.
3. Incorporate the coalescence-dispersion model for finite rate mixing into an existing interactive code AVCO-MARK I, to enable simulation of a combustor as a modular array of stirred flow and plug flow elements, each having a prescribed finite mixing frequency, or axial distribution of mixing frequency, as appropriate.
4. Further increase the speed and reliability of the batch kinetics integrator code CREKID [3] by rewriting in vectorized form for execution on a vector or parallel processor, and by incorporating numerical techniques which enhance execution speed by permitting specification of a very low accuracy tolerance [4].

REFERENCES

1. Pratt, D. T.: Mixing and Chemical Reaction in Continuous Combustion, in Progress. Progress in Energy and Combustion Science, vol. 1, N. A. Chigier, Ed., Pergamon Press, 1976.
2. Pratt, D. T.: Coalescence/Dispersion Modeling of High Intensity Combustion, AIAA J. Energy, 3, 3, 177180, 1979.
3. Pratt, D. T.: CREKID: A Computer Code for Transient, Gas-phase Combustion Kinetics, Paper No. WSCI 8321, Western States Section/The Combustion Institute, 1983.
4. Pratt, D. T.: Exponential-Fitted Methods for Integrating Stiff Systems of Ordinary Differential Equations: Applications to Homogeneous Gas-Phase Chemical Kinetics, paper presented at the 1984 JANNAF Propulsion Meeting, New Orleans, LA., February 1984.

ORIGINAL PAGE IS
OF POOR QUALITY

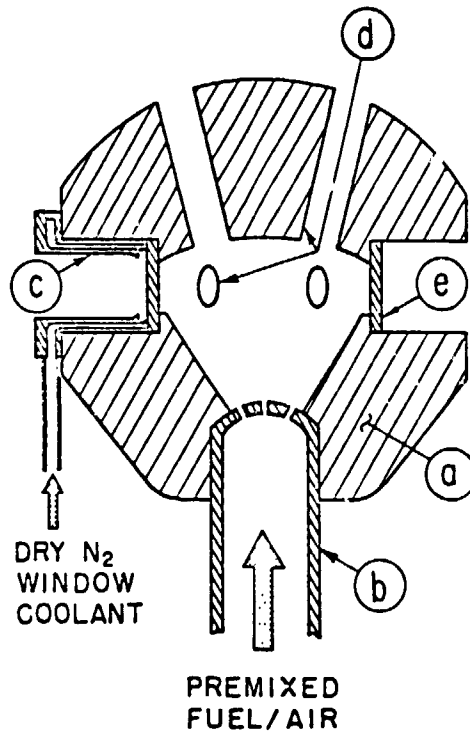

Figure 1. Jet-stirred reactor with optical access [2]. Details (a) sapphire reactor wall; (b) reactant feed tube; (c) spring-loaded window holder; (d) exhaust ports; and (e) sapphire window

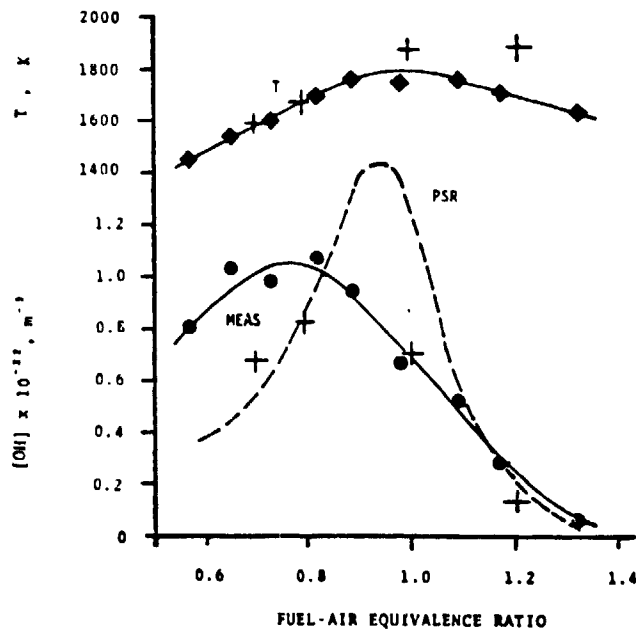

Figure 2. Measured and (homogeneous PSR) predicted OH, and uncorrected thermocouple temperature for combustion of CH₄/air at $\dot{m}/V = 19$ kg/cu m/sec. [2] Crosses are values predicted from CDJBR code with NT = 20.

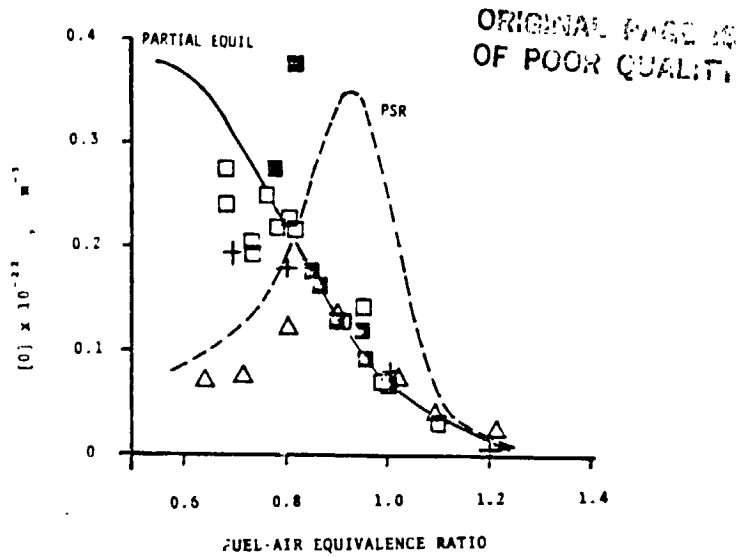

Figure 3. Measured [O] normalized by O-OH equilibrium, and (homogeneous PSR) predicted [O] for combustion of CH₄/air at $\dot{m}/V = 19$ kg/cu m/s. Crosses are predicted values from CDJBR code with NT = 20.

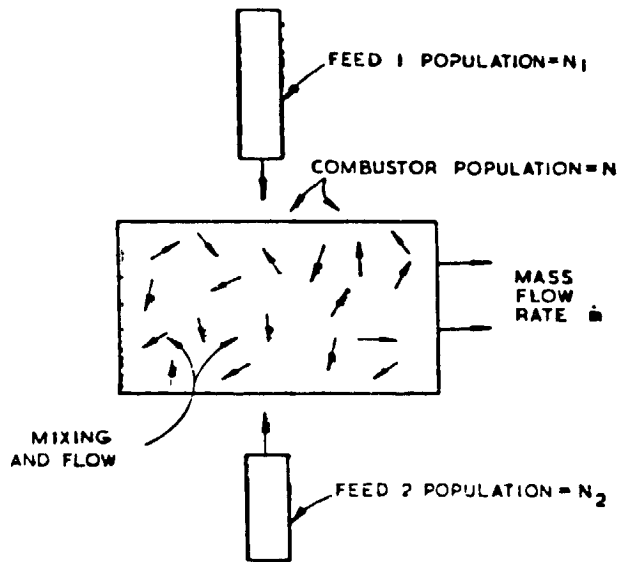
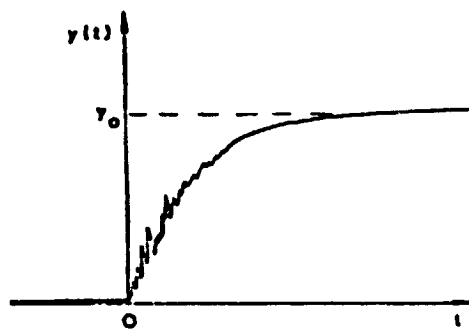
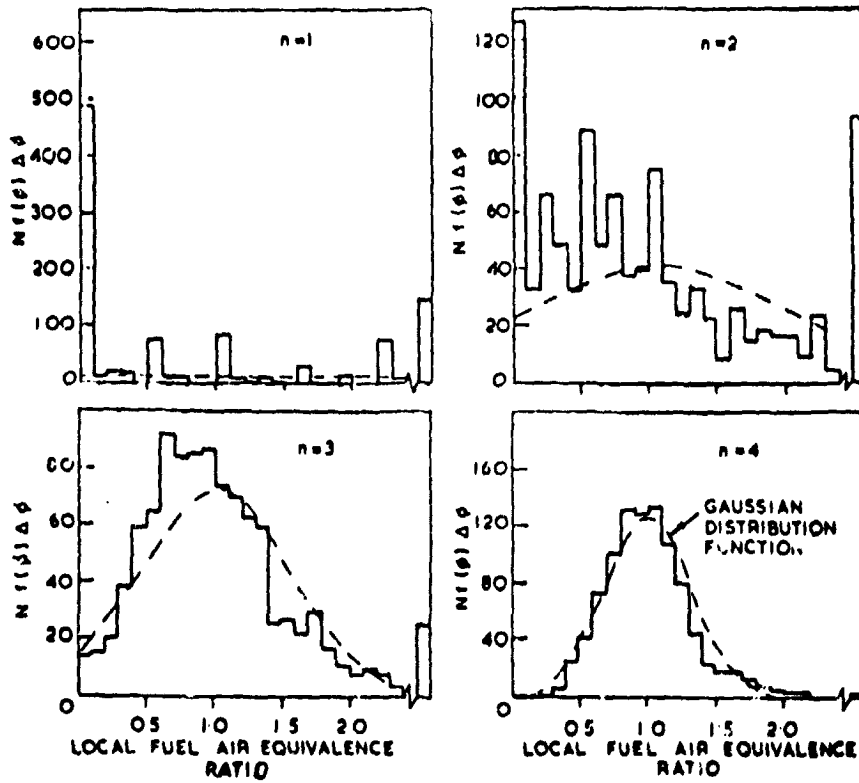
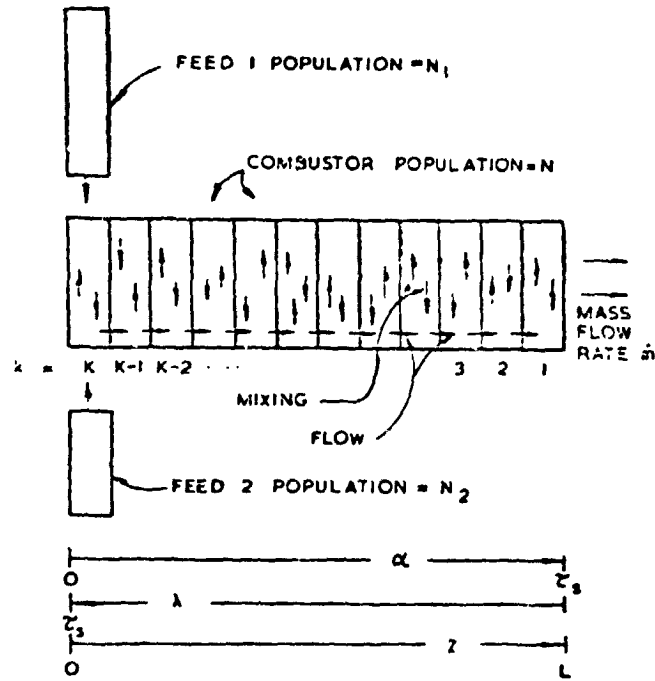

FIG 4 1



ORIGINAL PAGE IS
OF POOR QUALITY



ORIGINAL PAGE IS
OF POOR QUALITY

*** MARK2I ***

'MARK2I' IS AN INTERACTIVE VERSION OF THE MARK-II COMBUSTOR MODEL. THIS IS A PRELIMINARY DESIGN TOOL, A MEANS OF GAINING INTUITIVE INSIGHT INTO EFFECTS OF CHANGES IN FUEL-AIR MIXING OR PARTITIONING ON TURN-DOWN RATIO, COMBUSTION EFFICIENCY AND POLLUTANT FORMATION RATES. AN INITIAL DATA SET IS TAKEN FROM DATA FILE 'MARK2.DAT' BUT CAN BE ALTERED INTERACTIVELY, AND USED IN CONSECUTIVE RUNS.

MARK-II REPRESENTS A SIMPLE BRAGG COMBUSTOR CONSISTING OF A MAXIMUM OF 9 FLOW ELEMENTS WITH THE ADDITION OF A SINGLE RECYCLE ELEMENT. FLOW ELEMENT TYPES MAY INCLUDE:

- 1) NON-REACTING MIXERS ('MIX'), IN WHICH THE CHEMICAL REACTIONS ARE ASSUMED TO HAVE STOPPED DURING THE MIXING PROCESS;
- 2) PERFECTLY STIRRED REACTORS ('PSR'), WITHIN WHICH INTENSE SELF- OR BACK-MIXING IS ASSUMED TO OCCUR, SO THAT THERE ARE NO AXIAL GRADIENTS;
- 3) PLUG FLOW REACTORS ('PFR').

THE USER MAY DEFINE THE MODEL AS HAVING UP TO 9 ELEMENTS IN SERIES WITH AIR AND FUEL INLET JETS AT EACH ELEMENT. THE RECYCLE ELEMENT MAY BE OF ANY OF THE THREE FLOW TYPES, AND MUST RECYCLE FROM A HIGHER NUMBERED ELEMENT TO A LOWER. COOLING BOUNDARY LAYER EFFECTS AND CHEMICAL REACTIONS WITHIN THE BOUNDARY LAYER ARE NOT CONSIDERED.

--- PLEASE WAIT A MOMENT WHILE INITIALIZATION IS COMPLETED.

--- INITIALIZED -- PRESS RETURN TO BEGIN --

*** INPUT DATA ***

FLOW ELEMENT	AREA (SQ. IN)	LENGTH (INCHES)	FLOW TYPE	INLET AIR (LBM/S)	INLET FUEL (LBM/S)
1	1.4600E+02	4.0000E-01	PSR	1.3450E+00	9.7200E-02
2	1.4600E+02	1.0000E-01	MIX	6.9500E-01	0.0000E-01
3	1.4600E+02	1.5000E+00	PSR	0.0000E-01	0.0000E-01
4	1.4500E+00	2.0000E-01	MIX	7.9500E-01	0.0000E-01
RECYCLE	1.4600E+02	1.0000E+00	MIX	RECYCLE 20.00% OF # 3 OUTFLOW TO # 2 INFLOW	

AIR TEMP = 2.1000E+02 F
FUEL TEMP = 8.0000E+01 F

COMBUSTOR PRESSURE = 2.2100E+00 ATM
LOWER HEATING VALUE = 1.8500E+04 BTU/LBM

SELECT AN OPTION BY NUMBER:

- | | |
|--------------------------------|---------------------------------------|
| 0- RUN WITH THIS DATA SET | -4- CHANGE NOMINAL COMBUSTOR PRESSURE |
| -1- CHANGE AIR TEMPERATURE | -5- CHANGE RECYCLE ELEMENT STATUS |
| -2- CHANGE FUEL TEMPERATURE | -6- CHANGE FLOW ELEMENTS STATUS |
| -3- CHANGE LOWER HEATING VALUE | -7- INSPECT SCHEMATIC MODEL LAYOUT |
- OPTION? (0-7) 7

MARK-II MODEL SCHEMATIC LAYOUT

```

      A F      A      A
      | |      |      |
      * * * * * * * * * * * * * *
      * 1 *  * 2 *  * 3 *  * 4 *
      *PSR*--*MIX*--*PSR*--*MIX*-->
      * * * * * | * * * * * | * * * * *
                  |           |
                  |   * * *   |
                  |   *CYC*   |
                  |<--*MIX*-->|
                  |           |
                  * * * * *
  
```

PRESS RETURN TO CONTINUE