

6.3A A TRANSCEIVER MODULE OF THE MU RADAR

S. Kato, T. Ogawa, T. Tsuda, and T. Sato

Radio Atmospheric Science Center, Kyoto University, Gokanosho, Uji 611, Japan

and

I. Kimura, and S. Fukao

Department of Electrical Engineering, Kyoto University, Sakyo-ku,
Kyoto 606, Japan

A Japanese group working on radar remote sensing has been constructing the MU (Middle and Upper Atmosphere) radar since 1981, which is a pulse-modulated monostatic doppler radar operating at 46.5 MHz with a bandwidth of 1.65 MHz. It is situated at 34.85°N and 136.13°E, where the L value is 1.208 and the dip angle of the local magnetic field is 42.38°. The general design concept of the MU radar was studied by FUKAO et al. (1980), although several modifications were carried out in accordance with recent investigations. An updated block diagram is shown in Figure 1. One of the main characteristics is that the MU radar adopts an active array system in which each antenna is connected to a solid-state transceiver module (TR module).

The MU radar will attain a peak power of 1 MW with a duty factor of 0.05 by using 475 TR modules so as to observe three components of wind velocity in the altitude range 2-300 km with good height resolution. However, only 57 TR modules (3/25 of the whole system) have been installed up to now, so that the present peak transmitting power is 120 kW. In this report, we describe a block diagram of the TR module and a preliminary result of the power amplifier which is the main part of the TR module.

The TR module used in the MU radar is mainly composed of two units: a mixer (MIX unit) and a power amplifier (PA unit) whose block diagrams are shown in Figure 2a and b, respectively. The former generates the RF wave for transmission and converts the received echo to the IF signal. An arrow in the figure indicates a control signal from the radar controller. A 41.5-MHz local signal fed to mixers passes through a digitally controlled 8-bit phase shifter which can change its value up to 1,000 times in a second, so that the MU radar has the ability to steer its antenna direction quickly and flexibly. The MIX unit also contains a buffer amplifier and a gate for the transmitting signal and pre-amplifier for the received one whose noise figure is less than 5 dB.

The PA unit amplifies the RF signal supplied from the MIX unit up to 63.7 dBm (2350 W), and feeds it to the crossed Yagi antenna. The younger stage amplifier operates in A-class and gains 39.5 dB, while the final stage one is composed of four push-pull amplifiers whose gain is 12 dB. A TR switch attains an isolation of 100 dB between TX and RX signals by using high power PIN diodes. A band-pass-filter is inserted after the TR-switch and prevents unnecessary harmonics from transmitting. Phase and intensity of the transmitting signal and the value of VSWR are monitored by using a directional coupler. The output circuit can give linear, right and left circular polarizations. Signal level at three points and gain of both driver and final amplifiers are shown in Figure 2b. An over-all gain of the PA unit is about 50 dB.

Figure 3 shows input output characteristics of the PA unit. The output increases linearly up to 2350 W for the input signal in the range from 5 to 13 dBm, and saturates because of an action of the APC (automatic power control). Considering loss in connecting cables to the antenna, the final radiation power

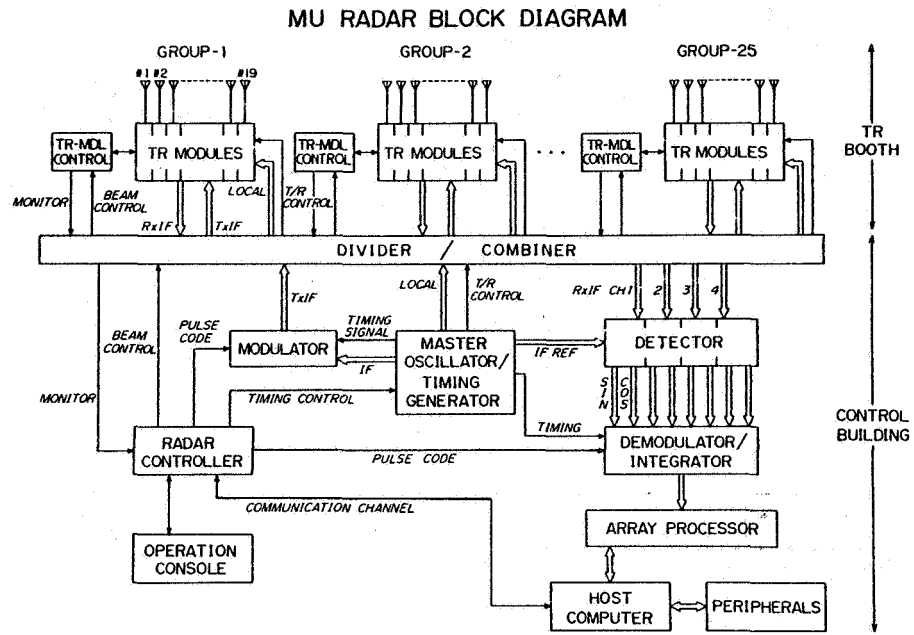

Figure 1. A block diagram of the MU radar.

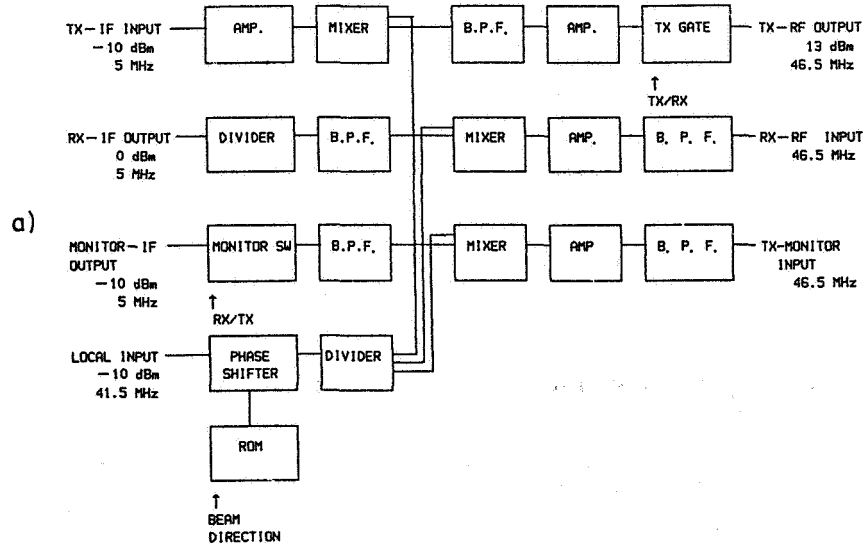

Figure 2(a). Block diagram of the MIX unit of the transceiver module used in the MU radar.

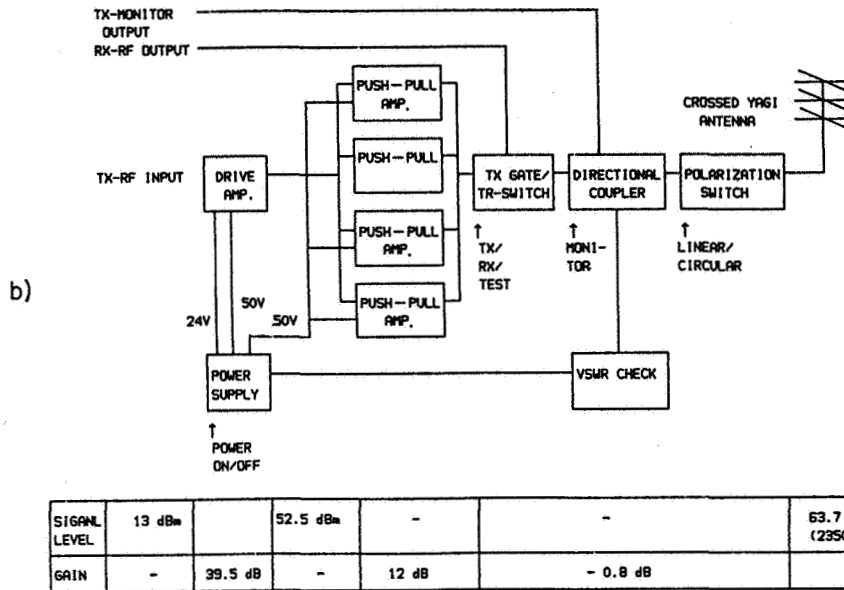

Figure 2(b). Block diagram of the PA unit of the transceiver module used in the MU radar.

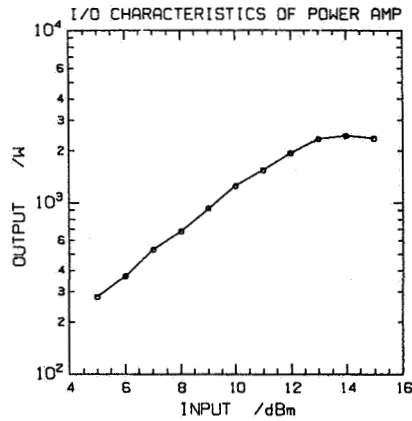

Figure 3. Input/output characteristics of the PA unit.

Considering loss in connecting cables to the antenna, the final radiation power will become 2050 W.

The TR module of the MU radar is manufactured by the Communication Equipment Works of Mitsubishi Electric Co.

REFERENCE

Fukao, S., S. Kato, T. Aso, M. Sasada and T. Mikihira (1980), Radio Sci., 15, 225-231.