

8. DATA PROCESSING TECHNIQUES USED WITH MST RADARS: A REVIEW
(Keynote Paper)

P. K. Rastogi

Haystack Observatory
Massachusetts Institute of Technology
Westford, MA 01886

ABSTRACT

The data-processing methods used in high-power radar probing of the middle atmosphere are examined in this paper. The radar acts as a spatial filter on the small-scale refractivity fluctuations in the medium. The characteristics of the received signals can be related to the statistical properties of these fluctuations. A functional outline of the components of a radar system is given. Most computation-intensive tasks are carried out by the processor. The processor computes a statistical function -- usually the power spectrum, or equivalently the autocovariance function -- of the received signals, simultaneously for a large number of ranges. The slow fading of atmospheric signals is used to reduce the data input rate to the processor by coherent integration. The inherent range resolution of the radar experiments can be improved significantly with the use of pseudo-noise phase codes to modulate the transmitted pulses and a corresponding decoding operation on the received signals. Commutability of the decoding and coherent-integration operations is used to obtain a significant reduction in computations. The limitations of the currently used processors are outlined. At the next level of data-reduction, the measured function is parameterized by a few spectral moments that can be related to physical processes in the medium. The problems encountered in estimating the spectral moments in the presence of strong ground clutter, external interference, and noise are discussed. Some salient steps involved in the subsequent (often ad hoc) graphical and statistical analysis of the inferred parameters are outlined. The requirements for special-purpose processors for MST radars are briefly discussed.

INTRODUCTION

Over a decade has passed since the pioneering experiments at Jicamarca, Peru (WOODMAN and GUILLEN, 1974) and Millstone Hill (CRANE, 1980), that became the forerunners of the modern high-power radar studies of the middle atmosphere, were performed. These experiments established that powerful radars can detect clear-air turbulence at heights extending to well within the mesosphere and use it as a tracer for the larger scale motions -- winds and waves -- in the middle atmosphere. As a result, almost all the existing ionospheric incoherent-scatter radars also are used for studies of the mesosphere-stratosphere-troposphere (MST) region. Several new MST radars have been constructed within the last decade, and others are nearing completion or planned. The use of these radars for studies of the dynamics and turbulence in the middle atmosphere involved several levels of signal and data processing operations. It is the object of this paper to outline and review these operations.

The impact of the recent electronic data-processing innovations is clearly manifest in the amount of data handled in the currently used MST radar experiments, and especially in the rate at which it is processed. In the original single-altitude experiments at Jicamarca, 60,000 complex additions and 500 complex multiplications were performed each minute (GUILLEN, 1971). The number of operations in a typical S-T experiment at Arecibo, e.g., would be larger by four or perhaps five orders of magnitude (WOODMAN, 1980). Over 50 million spectra may already have been collected or analyzed in MST radar experiments during the past decade.

We begin with a functional description of the components of a radar system. Then following in respective order, a discussion of the advantages and limitations of coherent integration as a computation-saving intermediate step; the use of binary phase codes and decoding results in an improvement in spatial resolution; and the methods of computing the spectra or autocovariance functions of the received signals in the processor. The limitations of general-purpose processors in carrying out these computations in real time, and the need for special-purpose processors with larger memory, especially for UHF radars, also are discussed in this section. Next, the methods of reducing the spectra or the autocovariance functions to a few basic spectral moments, particularly in the presence of strong ground clutter, are reviewed; the use of statistical editing techniques and treatment of missing data in the analysis of derived parameters; and finally, a brief discussion of some possible future developments in MST radar data processing.

FUNCTIONAL BLOCKS

A schematic block diagram of a typical MST radar system is shown in Figure 1. The functions of these blocks are outlined below.

The antenna is shared by the transmitter and the receiver system through a Duplexer. The transmitter is controlled by a modulator, and sends out narrow pulses, few tens of μs in width and about 1 MW peak power, at a typical pulse repetition interval (PRI) of 1-2 ms. In high altitude resolution experiments, the phase of the transmitted pulse can be modulated within the pulse in accordance with code(s) supplied by a code generator.

The receiver is connected to the antenna through the duplexer, shortly after the transmitter modulation is turned off. For UHF radars the front end of the receiver, usually a wide-band low-noise parametric amplifier, is mounted physically on the antenna. The receiver amplifies the RF signal and converts it to a lower intermediate frequency (IF). The IF signal is band-limited through a filter that is nominally matched either to the pulse length or, in experiments that use phase codes, to the baud length of the codes. The complex envelope of the IF signal is recovered through a pair of in-phase and quadrature phase detectors. The real and imaginary parts of this envelope are sampled in range and digitized with analog-to-digital converters. The duplexer must disconnect the receiver from the antenna after samples at all useful ranges have been obtained.

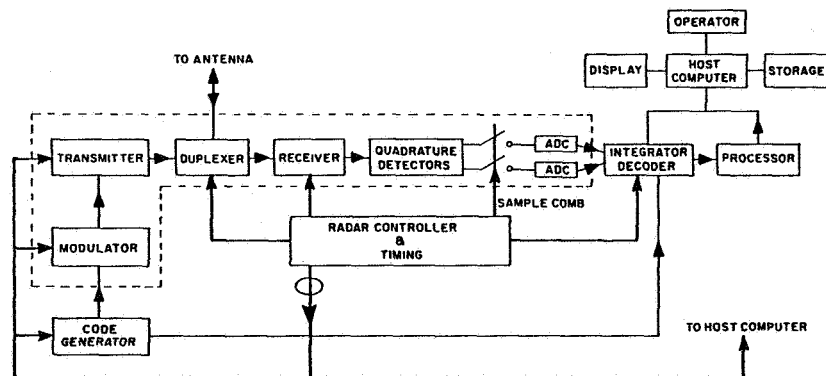

Figure 1. Block diagram for a typical MST radar. The signal flow is shown by thin lines, and the control flow by heavy lines. The control functions are not explicitly shown. The functions carried out in the blocks enclosed by the dotted lines are assumed to be linear.

The digitized signals are coherently integrated over several sweeps to reduce their bandwidth. If phase codes are used, the coherently integrated samples are correlated in range with the code pattern to effect decoding. It is, of course, necessary to temporarily store the integrated samples separately for each code.

From the integrated and decoded samples, the processor obtains time-averaged estimates of either the power spectrum, $S(f)$, or the autocovariance function, $R(\tau)$, of the received signal. The radar responds only to those components of the refractivity fluctuations within the scattering volume that have a spatial scale of $\lambda/2$ corresponding to the Bragg vector along the radar axis. Parameters inferred from the spectra or the autocovariance function of the received signal can be related to the statistical properties of the refractivity fluctuations at the Bragg scale under fairly general conditions as discussed, e.g., by TATARSKII (1971) and ISHIMARU (1978). The most widely used parameters are the low-order spectral moments of the received signal. The spectral-moment processing frequently is carried out off-line.

Synchronization between the radar modules is effected through the radar controller. The overall transfer of digitized and processed data between the modules, and to the outside world for storage, display and further analysis, is exercised through an on-line host computer.

The signal-processing operations performed by the analog blocks (enclosed by dotted lines in Figure 1), and subsequently by the processor, assume linearity of the system. For this reason, it is crucial to avoid saturation of these modules.

COHERENT INTEGRATION

A direct Fourier analysis of the signals received at the PRI, T is undesirable for two reasons: (1) the frequency band $(-0.5T, +0.5T)$ is considerably wider than the expected Doppler shift of the signals, and (2) the processor can store only a finite number N of samples for each range and the available frequency resolution $1/TN$ may not adequately resolve the Doppler-shifted returns. It is, therefore, necessary to reduce the bandwidth of the signals by low-pass filtering. This also would result in a better overall signal-to-noise ratio (SNR), due mainly to the reduced bandwidth.

Coherent integration of the received signals, in which the signals are accumulated for a time MT and then fed to the processor at this reduced rate, provides a simple and computationally effective means of implementing a low-pass filter. The use of coherent integration was proposed first by WOODMAN and GUILLEN (1974), and is now standard in all MST radar experiments. The only exceptions to its use arise in UHF radar experiments, at low elevation angles and at mesospheric heights.

The coherent-integration method is equivalent to a convolution or moving average of the received signal with a rectangular window followed by coarse sampling at intervals of the window length. Since the coefficients of this window are all of unit weight, its implementation does not involve multiplications and needs only one storage location per range for the partial sums. The frequency response of the coherent-integration filter has been discussed by SCHMIDT et al. (1979). It approximates an ideal low-pass filter rather poorly. Its simple implementation, however, has strongly favored its use with MST radars.

Use of better low-pass filters is desirable for reducing external interference. Improved low-pass filters can be obtained through smoother and wider time windows (see e.g., OPPENHEIM and SCHAFFER, 1975; RABINER and GOLD, 1975). The use of these improved filters involves, however, additional storage for the filter weights and for storing the partial product sums, and a large number of

extra multiplications. Their implementation would require a specially designed preprocessor. Alternatively, improved low-pass filters can be implemented directly in the frequency domain by bandlimiting, provided that the processor has adequate storage and Doppler resolution. Neither of these approaches appear to have been pursued with the existing MST radars.

PHASE CODES AND DECODING TO IMPROVE THE RANGE RESOLUTION

The use of a narrow transmitted pulse and bandlimiting at the IF stage delineates for each sampled range a scattering volume in space. If the transmitted pulse shape is $p(t)$, and the impulse response of the receiver system after correcting for a constant delay is $h(t)$, then the shape of the scattering volume at a range delay t along the radar axis is given by the convolution $(c/2) p(t) \otimes h(t)$. In a direction orthogonal to the radar axis, the scattering volume is confined by the antenna beamwidth. A pulse width of 10 μ s and a height resolution of 1.5 km is typical for MST radars, but it is inadequate for resolving the individual layers of turbulence that often are thinner than 100 m. The pulse width often can be reduced without an appreciable increase in the transmitter peak power. This would result in an improved resolution, but at the cost of decreased sensitivity at far ranges. The use of phase coding circumvents these limitations.

In coding schemes, a $0^\circ/180^\circ$ phase modulation is imposed on the transmitted pulses in accordance with a given code $w(t)$. The receiver-system impulse response $g(t)$, once again after correcting for a delay, should now be matched to baud rate $[\tau_b]$ for the code $w(t)$. In decoding, the received signal is correlated with $w(t)$. The corresponding operation in range is now

$$(c/2) \sum_{t'} [w(t') \otimes g(t')] \times w(t+t')$$

For desirable codes, their autocovariance function

$$\sum_{t'} [w(t') \times w(t+t')]$$

should behave like noise, i.e., it should peak only in the vicinity of $t=0$. This results in a range resolution of the order of $(c/2) \times \tau_b$.

The same argument can be extended for a linear system to sets of codes, e.g., to complementary code pairs, provided that the atmospheric signal may be regarded as coherent over the time required to cycle through the entire code set (WOODMAN et al., 1980). As discussed in the previous section, this often is the case. Complementary code pairs (RABINER and GOLD, 1975) have the nice property that the "sidelobes" in the autocovariance functions for the codes in the pair are equal and opposite and cancel on addition. In practice, this cancellation is not perfect. Implementation of complementary-code schemes for specific radar systems is discussed by SCHMIDT et al. (1979) and WOODMAN (1980). At present these codes are being used with the SOUSY, Arecibo, Millstone Hill and Poker Flat radars.

Since the codes are binary (i.e., have two levels of phase shift), the decoding operation involves only a one bit - multiple bit correlation of the code with the received signal. This correlation can be computed as a gated sum of the received signal, but still needs to be evaluated at the baud rate. For a 32-baud code and a 1 μ s baud rate, decoding involves 32 logical operations and additions within the baud duration of 1 μ s. For coherent signals, a remarkable reduction in the number of computations is possible by coherently integrating the signals before they are decoded (WOODMAN et al., 1980). For such signals, the dc bias in the system can be substantially reduced by successively sending the codes and their inverse, and correcting for the inverted codes by changing the sign of the received signals.

An extensive empirical search for "improved" practical code sets at specified sidelobe levels has been made by M. P. Sulzer. Practical implementation of such codes will require special hardware decoders, and is feasible with the available special purpose VLSI processors.

Complementary code pairs are not usable in mesospheric (incoherent-scatter) experiments with UHF radars, or in UHF experiments at low elevation angles. This is because the signals received in these experiments have a wide bandwidth and lack coherence from pulse to pulse. Barker codes are more practical in mesospheric incoherent-scatter experiments, and have been used for over a decade (IOANNIDIS and FARLEY, 1972).

AUTO-COVARIANCE FUNCTION AND POWER SPECTRUM ANALYSIS

The principal function of the processor is to form the estimates of the power spectrum density (PSD) or the autocovariance function (ACF) of the received signals from the coherently integrated and decoded samples, simultaneously for a large number of range cells.

To carry out this function, the processor must have sufficient storage for the samples and the intermediate results, and adequate speed to keep up with the computations in real time and to avoid a backlog. Depending on the storage capacity and speed of the processor, it is configured to operate in either a single-buffer or a double-buffer mode. In the single-buffer mode, the radar operation must be halted to allow the processor to catch up with the processing of the stored data. In the double-buffer mode, sufficient memory must be available to maintain two data storage areas with one always free to receive data while the other is being processed, and the time to process the data in one area must be shorter than that required to replenish the other. When these conditions are met, the double-buffer mode allows uninterrupted radar operation. Both the modes are used in MST data processing, depending upon the installation.

It is perhaps relevant to point out that the data input rate to the processor depends upon the radar frequency. The operating frequency for VHF radars (50 MHz) is about ten times lower than for UHF radars (430 MHz). Under identical circumstances the UHF signals will have a Doppler shift and spread that is ten times that for VHF signals. The data input rate to the processor will therefore be faster by a factor of 10 for UHF radars. The computational requirements correspondingly are more stringent for UHF radars.

The ACF processing is most simply implemented by using the method of lagged products (BLACKMAN and TUKEY, 1959). For computing the ACF at m equispaced lags, the processor must maintain a history of m samples and must have a similar amount of storage for updating the lagged-product sums. For each new sample, the m complex product sums are updated. After processing a sufficient number (L) of samples, the product sums are normalized to obtain the ACF. The ACF processing requires approximately $(m \times L)$ complex multiplications and additions per range. The principal incentive for the use of ACF processing is the set of simple relations between the spectral moments and the derivatives of the ACF at zero lag (WOODMAN and GUILLEN, 1974; MILLER and ROCHWARGER, 1972). In principle, the most useful spectral moments can be estimated from the ACF values at just 3 or 4 suitable lags. For large values of m , the lagged product method becomes inefficient and is rarely used (see, however, HARPER and WOODMAN, 1977).

The PSD can be estimated directly from the coherently integrated and decoded samples using the method of averaged periodograms. The periodograms of an equispaced sequence is defined as the magnitude squared of its discrete Fourier transform (DFT). The DFT is efficiently implemented with fast Fourier transform (FFT) algorithms (OPPENHEIM and SCHAFER, 1975; RABINER and GOLD, 1975). A finite number ($m = 2^k$) of samples is stored in the processor memory,

and transformed in place with the FFT method. The transform involves usually $m \times \log_2 m$ complex multiplications. The periodogram is then computed as the square of the DFT, and averaged in time to obtain an estimate of the PSD. The method of averaged periodograms is now routinely used in MST radar experiments. It was used first at the Sunset radar by GREEN et al. (1975).

Statistical properties of the ACF and the PSD estimates have been discussed in detail in several texts (JENKINS and WATTS, 1969; KOOPMANS, 1976; PAPOULIS, 1977). The averaged periodogram $P(f)$ gives a distorted estimate of the true PSD $S(f)$, and its DFT also is a poor estimate for the ACF $R(\tau)$. This distortion is particularly significant in the presence of a strong, slowly fading ground clutter as discussed below.

The method of averaged periodogram for an m -point sequence is equivalent to applying a triangular window over a base $(-m, +m)$ on the ACF. Because of the discrete nature of the sequences and their transforms, the windowed ACF is periodic and its components outside $(-m, +m)$ are aliased. This aliasing is particularly significant if the ACF extends beyond $-m/2, +m/2$. The triangular window causes a smearing of discrete frequency components with a frequency window that decays slowly as f^{-2} .

A simple way of avoiding the distortion due to aliasing of the ACF is to append the m -point sequence with m or more zeros before the DFT operation. This is a well-known technique for estimating the ACF of a sequence with the DFT methods (RABINER and GOLD, 1975). It does, however, require extra storage capacity in the processor and perhaps for this reason has received scant attention for MST radar applications. The smearing of the discrete frequency components arises due to the finite length m of the sequences that are transformed. The only way to reduce this smearing is to increase m (i.e., the duration of the sequence), that is limited once again by the processor memory.

Two current developments in the field of digital signal processing (DSP) are worth mentioning as they are likely to have some impact on future MST radar processing.

The first development pertains to the parametric spectral analysis methods that increasingly are being used in signal-processing applications (CHILDERS, 1978; HAYKIN and CADZOV, 1982; DURRANI, 1983). The spectral analysis methods currently used with MST radars, e.g., the Blackman-Tukey method, are non-parametric in the sense that they do not use any specific model for the received signal. Parametric methods assume an underlying model for the process (received signal) being analyzed and, provided that the process adheres to this model, can provide excellent frequency resolution. A rather general class of these models assumes that the process is obtained by filtering white Gaussian noise through a pole-zero filter (MAKHOUL, 1975; GUTOWSKI et al., 1978), though the order of this filter needs to be determined empirically. An examination of MST radar spectra suggests that they can probably be characterized by an all-pole model. Exploratory spectral analysis of sequences of coherently integrated samples from VHF and UHF radars, with the methods outlined above, appears to be a very promising project.

The second development pertains to the declining cost of large addressable memory modules and the availability of special-purpose microcomputers (μ Cs) for DSP applications (MAGAR et al., 1982; ALLAN, 1982). A 16-bit 256-kiloword addressable memory module with 500 ns access time is currently priced at \$2500. Programmable DSP μ Cs, that can compute a 64-point complex FFT in 2 ms, are also currently available. It appears that special-purpose processors for MST radar applications can be implemented inexpensively with a large addressable memory module and several DSP μ Cs.

SPECTRAL-MOMENT PROCESSING: GROUND-CLUTTER REMOVAL

At the next level of processing, the PSD or ACF estimates are used to obtain the basic spectral moments. The three lowest-order moments, defined below, are of special interest:

$$S_0 = \int_{-\infty}^{+\infty} S(f) df$$

$$S_1 = [\int_{-\infty}^{+\infty} f S(f) df] / S_0$$

$$S_2 = [\int_{-\infty}^{+\infty} (f-S_1)^2 S(f) df] / S_0$$

These moments denote, respectively, the total power, Doppler shift and Doppler spread of the signals. The integrals in these definitions are over $|f| < \infty$. In practice the spectra are localized, and the moments must be evaluated over a limited frequency window F as discrete sums. In order that these sums converge to the true moments, a good frequency resolution is desirable. The definitions show that even for localized spectra, for the moment of order k to exist, the spectra must decay at least as fast as f^{-k} away from S_1 . To minimize the contribution of a constant (noise) part of the spectrum on the moments, and to reduce their dependence on the window function F , the constant part must be subtracted from $S(f)$. Moreover, for localized spectra the definitions become nested. It therefore becomes necessary to determine these moments recursively, and to use several different windows F . The moments then should converge most rapidly for that window F that matches the shape of the spectrum best. Any prior information about S_1 , e.g., from previous observations or from adjacent range cells, can be used for setting up the window F . This makes the estimates more robust and less susceptible to external interference.

The spectra estimated as averaged periodogram $P(f)$ usually have a large variance (Koopmans, 1976) that hinders the task of spectral-moment estimation. Some prior smoothing of $P(f)$, e.g., with a 3-point running window, is desirable. Smoothing also helps in forming an automatic initial guess for the location of the signal, e.g., as a local maximum, in the spectrum.

As already mentioned in the previous section, the spectral moments can be inferred efficiently from estimates of the ACF at small lags. This method is similar to that of obtaining the moments of a probability density from its characteristic function (Papoulis, 1977). S_0 is simply the value of the ACF at zero lag, S_1 is directly related to the phase of the ACF at a small lag, and S_2 is related inversely to the width of ACF (Miller, 1974). The use of this method in atmospheric radar experiments is discussed by Woodman and Guillen (1974) and Zrnic' (1979).

The ground clutter poses a serious problem in estimating the spectral moments. The contribution of ground clutter often is 10 to 30 dB stronger than the atmospheric signal and has a small but finite bandwidth. In the periodogram method of estimating the PSD, this contribution invariably is smeared in frequency. This smearing is more severe at UHF frequencies.

A simple method of removing the ground-clutter component in the PSD estimates is to assume that this component has no Doppler shift. The ground clutter contribution would then be symmetric about the zero Doppler shift and can be easily removed. This method generally works well for VHF radars, but for

UHF radars it requires the atmospheric signals to be sufficiently well-separated in frequency from the clutter.

SATO and WOODMAN (1982) describe a parametric method of estimating the spectral moments for UHF radar signals in the presence of fading ground clutter. The PSD is characterized as the sum of three components: a parabolic, Gaussian or Lorentzian function for the ground clutter, a Gaussian function for the signal, and a Gaussian function for the ocean returns or external interference. This composite spectrum is transformed to an ACF that is aliased and distorted as described in the previous section, and fitted to the DFT of the measured periodograms in a least-square-error sense. The processing time for obtaining the best fit can be reduced substantially if an initial guess for the parameters is supplied. The (nonparametric) spectral-moment estimation methods discussed earlier can be useful for obtaining the initial guess.

Special processing techniques that reduce the smearing of the fading ground clutter in the PSD estimates are obviously desirable from the point of view of spectral-moment estimation. One such technique is to increase the frequency resolution of the periodograms by transforming a very long sequence of samples (WAND et al., 1983). This technique is limited by the processor memory. The second technique is to use parametric spectral-estimation methods (HAYKIN et al., 1982). The application of these techniques to MST radar experiments deserves attention.

DATA ANALYSIS: OUTLIERS AND MISSING DATA

Analysis of the MST radar data -- the spectral moments and physical parameters derived from these -- requires statistical, numerical and graphical techniques. Though the details of these analyses depend on the scientific objectives, some techniques that are useful in handling spurious points and missing data are worth mentioning.

Spurious data values or outliers frequently occur in physical data. Manual editing techniques to isolate and discard these values are impractical for large data sets. Techniques based on running statistics of data are effective in removing outliers. One such statistic is the median. A median filter examines a few points on either side of a data point and determines the local standard deviation and median. If the data value deviates too much from the median, it is classified as an outlier and replaced by the median. Properties of the median filters have been discussed by NODES and GALLAGHER (1982).

Runs of missing data can occur in a long sequence of radar observations for reasons such as equipment outage, interference or weak signal level. Spectral analysis of a sequence with missing data requires extra care. BLACKMAN and TUKEY (1959) suggest modifications of their averaged lagged-product method of spectral analysis to sequences with gaps. In the periodogram method, missing data introduce unknown frequency components. The periodogram of an indicator function (with a value 1 for data and 0 for gaps) is useful for identifying these frequency components. Interpolation techniques, with spline functions e.g., are useful for smooth sequences with short gaps. BOWLING and LAI (1979) describe an interesting technique based on parametric spectral estimation methods for interpolation and spectral analysis of a sequence with missing data.

Graphical techniques are particularly valuable for examination and succinct displays of large amounts of geophysical data. The use of color graphics appears well established in fields such as remote sensing and radar meteorology, and will undoubtedly be useful for MST radar data analysis.

DISCUSSION

The techniques used in MST radar data processing appear to have become fairly well established. The processing of VHF radar signals follows the more standard procedures, due mainly to the large number of such radars (approaching ten) and the smaller data rate encountered at their operating frequencies. The number of UHF radars usable for ST studies is presently limited to two -- Arecibo and Millstone Hill -- though other incoherent-scatter radars in France, Greenland and Norway will probably soon be added to this list. The full steerability of the smaller UHF radars gives them a unique capability, but they require more specialized data processing methods.

Phase codes and decoding to achieve a better altitude resolution (300 m or better) are already in use with a few MST radars. Fully automated processing of radar data in real time -- up to the level of spectral-moment estimation -- appears to be a desirable goal for obtaining long, unattended sequences of observations, with manageable output data rates. At present this goal has been reached only at the Poker Flat radar.

Special-purpose hardware processors for FFT analysis, and preprocessors for filtering and decoding, can now be inexpensively constructed. For VHF radars a 512 channel processor with 64 point FFTs can cover the entire MST region with a 150-m height resolution. A similar processor for UHF radars will require 256 channels with 512 point FFTs to cover the entire ST region. Special-purpose preprocessors to carry out low-pass filtering and decoding for 512 or 256 channels are required for better interference rejection and improved height resolution.

The use of parametric spectrum and spectral-moment estimation methods needs to be explored, especially for the UHF radars, to overcome the problems related to ground clutter.

ACKNOWLEDGMENT

This material is based on work supported by the National Science Foundation under grant number ATM-8000060.

REFERENCES

- Allan, R. (1982), Signals processors enlist in a variety of advanced systems, Electronic Design, (Aug. 5), 75-86.
- Blackman, R. B. and J. W. Tukey (1959), The Measurement of Power Spectra, Dover, New York, 190 pp.
- Bowling, S. B. and S. T. Lai (1979), The use of linear prediction for the interpolation and extrapolation of missing data and data gaps prior to spectral analysis, Lincoln Lab. Rep., 1979-46, 19 pp., Lexington, Mass.
- Childers, D. G. (1978), Modern Spectrum Analysis, (selected reprints), IEEE Press, New York, 334 pp.
- Crane, R. K. (1980), A review of the radar observation of turbulence in the lower stratosphere, Radio Sci., 15, 177-193.
- Durrani, T. S. (ed.) (1983), Special Issue on Spectral Analysis, IEE Proceedings, Part F, 180(3), April 1983.
- Green, J. L., J. M. Warnock, R. H. Winkler and T. E. VanZandt (1975), Studies of winds in the upper troposphere with a sensitive VHF radar, Geophys. Res. Lett., 2, 19-21.

- Gullen, A. (1971), Measurements of winds up to 85 km altitude using radar and electronic digital computer, Engineer thesis, Nat. Univ. Engg., Lima, Peru.
- Gutowski, P. R., E. A. Robinson and S. Treitel (1978), Spectral estimation: Fact or fiction, IEEE Trans. Geosci. El., GE-16, 80-84.
- Harper, R. M. and R. F. Woodman (1977), Radar observations of waves and winds in the mesosphere over Jicamarca, J. Atmos. Phys. Terr., 39, 959-963.
- Haykin, S. and J. A. Cadzow (1982), Special issue on spectral estimation, Proc IEEE, 70(9), 883-1125.
- Haykin, S., B. W. Currie and S. A. Kesler (1982), Maximum-entropy spectral analysis of radar clutter, Proc. IEEE, 70(9), 953-962.
- Ioannidis, G. and D. T. Farley (1972), Incoherent scatter observations at Arecibo using compressed pulses, Radio Sci., 7, 763-766.
- Ishimaru, A. (1978), Wave Propagation and Scattering in Random Media, Academic, New York, 572 pp.
- Jenkins, G. M. and D. G. Watts (1969), Spectral Analysis and its Applications, Holden-Day, San Francisco, 525 pp.
- Koopmans, L. H. (1976), The Spectral Analysis of Time Series, Academic, New York, 366 pp.
- Magar, S., R. Hester and R. Simson (1982), Signal-processing μ C builds FFT-based spectrum analyzer, Electronic Design (Aug. 19), 149-154.
- Makhoul, J. (1975), Linear prediction: A tutorial review, Proc. IEEE, 63, 561-580 (also in Childers, 1978).
- Miller, K. S. (1974), Complex Stochastic Processes, Addison-Wesley, Reading, 238 pp.
- Miller, K. S. and M. M. Rochwarger (1972), A covariance approach to spectral moment estimation, IEEE Trans. Inf. Th., IT-18, 588-596.
- Nodes, T. A. and N. C. Gallagher, Jr. (1982), Median filters: Some modifications and their properties, IEEE Trans. Ac. Ap. Sig. Proc., ASSP-30, 739-746
- Oppenheim, A. V. and R. W. Schaffer (1975), Digital Signal Processing, Prentice-Hall, Englewood Cliffs, NJ, 585 pp.
- Papoulis, A. (1977), Signal Analysis, McGraw-Hill, New York, 431 pp.
- Rabiner, L. R. and B. Gold (1975), Theory and Application of Digital Signal Processing, Prentice-Hall, Englewood Cliffs, NJ, 762 pp.
- Sato, T. and R. F. Woodman (1982), Spectral parameter estimation of CAT radar echoes in the presence of fading clutter, Radio Sci., 17, 817-826.
- Schmidt, G., R. Ruster and P. Czechowsky (1979), Complementary codes and digital filtering for detection of weak VHF radar signals from the mesosphere, IEEE Trans. Geosci. El., GE-17, 154-161.
- Tatarskii, V. I. (1971), The effects of the turbulent atmosphere on wave propagation, Nat. Tech. Inf. Serv., Springfield, VA, 472 pp.

- Wand, R. H., P. K. Rastogi, B. J. Watkins and G. B. Lorient (1983), Fine Doppler resolution observations of thin turbulence structures in the tropo-stratosphere at Millstone Hill, J. Geophys. Res., 88, 3851-3857.
- Woodman, R. F. (1980), High-altitude resolution stratospheric measurements with the Arecibo 430-MHz radar at Arecibo, Radio Sci., 15, 417-422.
- Woodman, R. F. and A. Guillen (1974), Radar observations of winds and turbulence in the stratosphere and mesosphere, J. Atmos. Sci., 31, 493-505.
- Woodman, R. F., R. P. Kugel and J. Rottger (1980), A coherent integrator-decoder preprocessor for the SOUSY-VHF radar, Radio Sci., 15, 233-242.
- Zrnic, D. (1979), Estimation of spectral moments for weather echoes, IEEE Trans. Geosci. El., GE-17, 113-128.

REPORT AND RECOMMENDATION

This report on the data processing techniques currently in use with MST radars is based on the contributions that were presented in two workshop sessions, and on an open discussion following these presentations. The contributions addressed the current methods, problems and new developments in the use of coherent integration, autocovariance function (ACF) and power spectrum density (PSD) analysis, estimation of spectral moments, pseudo-noise phase codes and decoding, and special-purpose processors in the analysis of radar data.

Coherent integration is an intermediate computation-saving step that reduces the data rate before PSD or ACF analysis. In experiments that use phase codes, it is often possible to carry out decoding after coherent integration with a remarkable saving in computations. In the frequency domain, coherent integration approximates a poor low-pass filter that arises due to the use of a rectangular time window. Other time windows with better frequency response are known, but their implementation is deemed impractical as it requires considerable extra storage and a steep increase in computations. The simplicity of implementing coherent integration remains a strong point in its favor.

The ACFs can be evaluated for a small number of lags as the lagged-product sums. The number of lags is eventually limited by the processor speed. More efficient implementations are possible for an assumed ACF shape, or indirectly with the use of discrete Fourier transform (DFT) methods. The use of DFT methods for ACF computations has not been deemed favorable as it requires a null extension of the data, hence extra storage in the processor. The PSDs are estimated most frequently with the method of averaged periodograms. The periodogram is efficiently computed from the DFT of data samples, but provides a distorted estimate of the spectrum. This distortion is most serious in the presence of a strong, slowly fading ground clutter.

Spectral moments, that contain information about the physical and dynamical characteristics of the medium, can be estimated directly from the spectra, or indirectly and often more efficiently from the ACF at small lags. In VHF radar experiments both methods have been successfully used. The ACF method can be implemented even with processors of modest speed and storage. In UHF radar experiments, the estimated spectra invariably are contaminated with a strong, slowly fading ground clutter. At pointing directions far from the vertical, the signals have a sufficiently large Doppler shift and can be readily discriminated from the clutter. Under these conditions simple ad-hoc methods can be used effectively for finding the spectral moments. For signals with small Doppler

shifts, the contribution of ground clutter and other undesired components must also be estimated. Parametric spectral moment estimation using nonlinear least square fitting has been found to be a useful and perhaps the only effective technique in this case.

Phase codes and decoding are used to improve the range resolution without degrading the received signal-to-noise ratio. For slowly fading MST returns the use of complementary code pairs can routinely provide altitude resolution of 150-300 m, except for close ranges. The use of coherent integration before decoding results in a substantial saving in computational effort and is often actually required for carrying out decoding in real time. Special hardware processors are usually necessary for decoding. For small code sets and slowly fading returns, decoding can be implemented in software for a limited height range. For large code sets, decoding must be carried out on a pulse-by-pulse or code-by-code basis. A fast hardware decoder has recently been designed and is under construction at the Arecibo Observatory.

Due to rapid advances in the technology of storage and signal-processing devices and their declining costs, it is now feasible to develop large, high-speed processors for MST radar applications. One such processor is currently being developed at the University of Alaska with two relatively inexpensive array processors and a large external buffer memory. A fast pipe-lined radar signal processor, suitable for MST and other applications, is under development at Cornell University.

The nature of ground clutter observed with the existing MST radars was briefly discussed. Since the ground clutter returns are tens to thousands of times stronger than the atmospheric returns, it is necessary to provide a large dynamic range in their digitization. An eight-bit digitization is often sufficient for VHF radars, but UHF radars may require up to twelve bits. The ground clutter returns fade much more rapidly at UHF due to the shorter wavelength. This fading is usually not a serious problem at VHF frequencies, except for conditions of strong ground wind. The ground clutter fading is usually more severe during the daytime, in precipitation environment, and during boundary-layer inversions. Further empirical studies of the nature of ground clutter fading and its severity are deemed essential. Spectral analysis of longer data records, with a finer Doppler resolution, offers a reasonable alternative for reducing the smeared contribution of fading ground clutter, but requires the use of processors with large storage.

The need for software exchange between radar groups was considered. At present the data processing software is implemented in a rather ad-hoc way within each user group. As more radars with similar characteristics are constructed (e.g., VHF ST radars), there certainly will be a need for standardization and exchange of such software.

Further open discussions regarding the current and future data processing needs at the existing and planned MST radar facilities led to the following recommendation:

"The group, NOTING with concern that many MST observatories have inadequate data processing facilities, and with pleasure that major advances in developing powerful but low cost digital equipment have been made in recent years, RECOMMENDS that existing observatories investigate the cost effectiveness of upgrading their computing facilities and that adequate attention be given to this topic in planning new facilities".