

NASA Contractor Report 3649

**Full-Scale Testing, Production,
and Cost Analysis Data for the
Advanced Composite Stabilizer
for Boeing 737 Aircraft**

Volume I - Technical Summary

**R. B. Aniversario, S. T. Harvey,
J. E. McCarty, J. T. Parsons,
D. C. Peterson, L. D. Pritchett,
D. R. Wilson, and E. R. Wogulis**
*Boeing Commercial Airplane Company
Seattle, Washington*

Prepared for
Langley Research Center
under Contract NAS1-15025



National Aeronautics
and Space Administration

**Scientific and Technical
Information Branch**

1983

FOREWORD

This technical summary (vol. I) and a final technical report (vol. II, ref. 1) were prepared by the Boeing Commercial Airplane Company, Renton, Washington, under NASA Contract NAS1-15025. They cover work performed between July 1977 and December 1981. The program was sponsored by the National Aeronautics and Space Administration, Langley Research Center (NASA-LRC). Dr. Herbert A. Leybold, Marvin B. Dow, and Andrew J. Chapman were the NASA-LRC project managers.

The following Boeing personnel were principal contributors to the program:

Program Director
S. T. Harvey

Design

G. Ohgi
R. J. Nicoli
E. R. Wogulis
W. C. Brown

Structural Analysis

D. R. Wilson
R. W. Johnson
J. E. McCarty

Weight and Balance Analysis

G. Nishimura
J. T. Parsons
R. E. Baum

Manufacturing Technology

M. C. Garvey
V. S. Thompson
E. S. Jamison

Production Manager

J. E. Gallant
W. D. Grant

Technical Operations Manager

L. D. Pritchett

Business Management

C. M. Lytle
M. R. Wiebe
D. V. Chovil

SUMMARY

This report is a technical summary for the full-scale testing, production, and cost analysis data for the advanced composite stabilizer for the Boeing 737 aircraft. It covers, along with References 1, 2, and 3, all work performed on the program from its inception in July 1977 through its conclusion in December 1981.

The principal program objective was to design, produce, and test an advanced composite 737 stabilizer that would meet the same functional criteria as the existing metal stabilizer. A full-scale left-hand ground test article was chosen that was structurally complete with elevator, balance panels, leading edge, trailing edge, closure rib, and associated hardware. The upper and lower skins and stringers, front and rear spars, ribs, and trailing-edge beam were fabricated from graphite-epoxy materials. The test stabilizer was supported in a horizontal position by using a structural steel test fixture. The composite stabilizer initially was subjected to four static load cases. It sustained design limit (67% ultimate) load for these cases. Afterwards, cyclic spectrum loads equivalent to 120 000 flights or one-and-one-half lifetimes were applied to the test article. Included as part of the cyclic loading were 80 000 spectrum flights with simulated service and/or maintenance damage. No structural damage or flaw growth of inflicted damage was found. It also was subjected to a number of fail-safe tests, one of which indicated that additional reinforcement using a plate integral with the fail-safe lug strap, the lower lug strap, and the spar web was necessary.

At the successful conclusion of all ground testing, the composite stabilizer was exposed to lightning strike tests. The full-scale test program met all FAA certification requirements.

Ground vibration and flight tests were performed using a production 737 aircraft with a graphite-epoxy stabilizer installed. In both cases, the composite stabilizer functioned completely within the counterpart aluminum-stabilizer-required envelope. The Federal Aviation Regulation 25 (FAR 25) was completely satisfied, and FAA certification was achieved during August 1982 (ref. 4).

Another prime program objective was to gain simulated production experience. This was accomplished by producing five-and-one-half shipsets of stabilizers using advanced composite materials. Experience was gained in estimating, tool development, and fabrication processes. The graphite subcomponents were produced by Boeing's Fabrication Division at Auburn, Washington. Assembly was accomplished at the Boeing facility in Wichita, Kansas, using conventional tools. The production assembly tools could not be used because the graphite assembly had fewer parts. Overall production problems were minimal.

The final objective of the program was to obtain realistic production cost data for the five-and-one-half shipset production run. Of the total production expenditures, labor was 85%, and nonlabor was 15%. Production labor was 64% for fabrication, 30% for assembly, and 6% for manufacturing research and development. Material usage factors for the program were 2.8 lb for fabric and 1.8 lb for tape for each pound of flyaway weight. With automation, these factors could be appreciably reduced. Recurring costs for 200 shipsets of advanced composite 737 stabilizers are estimated to be \$40.3 million.

The program was successful and well timed. The results will provide the necessary confidence for the company to commit use of graphite-composite structure in similar applications on future aircraft.

CONTENTS

	Page
1.0 INTRODUCTION	1
2.0 SYMBOLS AND ABBREVIATIONS	3
3.0 ANALYSIS AND TEST	5
3.1 Full-Scale Ground Test	5
3.2 Ground Vibration Test	8
3.3 Flight Tests	10
3.4 FAA Certification	15
3.5 Weights	15
4.0 PRODUCTION	17
4.1 Detail Tools	17
4.2 Assembly Tools	18
4.3 Overall Production	18
5.0 COST ANALYSIS	19
5.1 Production Costs	19
5.1.1 Production Environment	19
5.1.2 Total Costs	19
5.2 Composite Material Usage Factors	22
5.3 Cost Comparisons	22
6.0 CONCLUSIONS	25
7.0 REFERENCES	27

FIGURES

		Page
1	Test Setup—Full-Scale Ground Test.	5
2	Induced Damage Locations	7
3	Rear-Spar Failure—Load Case 4010 With Upper Pin Removed	9
4	Lightning Strike Test	10
5	Lightning Strike Test	11
6	Ground Vibration Test Setup.	12
7	Speed and Altitude Test Points.	14
8	Flutter Vane Installation	14
9	Total Recurring and Nonrecurring Production Costs by Major Element—5½ Shipsets	20
10	Total Recurring and Nonrecurring Component Production Labor Hours—5½ Shipsets	20
11	Total Recurring and Nonrecurring Production Labor Hours (Excludes Tooling and Engineering)	21
12	Total Recurring and Nonrecurring Fabrication Hours—5½ Shipsets	21
13	Total Recurring and Nonrecurring Assembly Labor Hours—5½ Shipsets	22
14	Relative Composite Stabilizer Cost Comparison— Initial 200 Shipsets	23

TABLES

		Page
1	Aluminum Versus Graphite-Epoxy Stabilizer Mode Comparison	13
2	Metal and Graphite-Epoxy Horizontal Stabilizers— Inspar Structure Weight Comparison	16
3	Predicted and Actual Composite Stabilizer Inspar Structure Component Weights	16

1.0 INTRODUCTION

The escalation of aircraft fuel prices has motivated assessment of new technology concepts for designing and building commercial aircraft. Advanced composite materials, if used extensively in airframe components, offer high potential for reducing structural weight and thereby direct operating costs of commercial transport aircraft. To achieve the goal of production commitments to advanced composite structures, there is a need to convincingly demonstrate that these structures save weight, possess long-term durability, and can be fabricated at costs competitive with conventional metal structures.

To meet this need, NASA has established a program for composite structures under the Aircraft Energy Efficiency (ACEE) program. As part of this program, Boeing has redesigned and fabricated the horizontal stabilizer of the 737 transport using composite materials, has submitted data to FAA, and has obtained certification. Five shipsets of composite stabilizers have been manufactured to establish a firm basis for estimating production costs and to provide sufficient units for evaluation in airline service. This work has been performed under NASA Contract NAS1-15025.

The broad objective of the ACEE Composite Structures program is to accelerate the use of composite structures in new transport aircraft by developing technology and processes for early progressive introduction of composite structures into production commercial transport aircraft. Specific objectives of the 737 Composite Horizontal Stabilizer program were to:

- Provide structural weight at least 20% less than the metal stabilizer
- Fabricate at least 40% by weight of the stabilizer constituent parts from advanced composite materials
- Demonstrate cost competitiveness with the metal stabilizer
- Obtain FAA certification for the composite stabilizer
- Evaluate the composite stabilizer on aircraft in airline service

To achieve these objectives, Boeing concentrated efforts on conceiving, developing, and analyzing alternative stabilizer design concepts. After design selection, the following were performed: materials evaluation, ancillary tests to determine material design allowables, structural elements tests, and full-scale ground and flight tests to satisfy FAA certification requirements. Specific program activities to achieve objectives included:

- Program management and plan development
- Establishing design criteria
- Conceptual and preliminary design
- Manufacturing process development
- Material evaluation and selection
- Verification testing
- Detail design
- FAA certification

Work accomplished in each of these areas is summarized in this document and described in detail in Reference 1.

NOTE: Certain commercial products are identified in this document in order to specify adequately the characteristics of the material and components under investigation. In no case does such identification imply recommendation or endorsement of the product by NASA or Boeing, nor does it imply that the materials are necessarily the only ones available for the purpose.

2.0 SYMBOLS AND ABBREVIATIONS

ATLAS	computer program
FAA	Federal Aviation Administration
FAR	Federal Aviation Regulation
LC	load case
M_D	flight boundary, design dive speed, Mach number
MR&D	manufacturing research and development
V_D	flight boundary, design dive speed, knots equivalent air speed (keas)

3.0 ANALYSIS AND TEST

3.1 FULL-SCALE GROUND TEST

The test article was a left-hand, full-scale, Boeing model 737 graphite-epoxy horizontal stabilizer that was structurally complete with elevator, balance panels, leading edge, trailing edge, closure rib, and associated hardware. The upper and lower skins and stringers, front and rear spars, ribs, and trailing-edge beams were fabricated from graphite-epoxy material according to production drawing requirements.

The test stabilizer was supported in a horizontal position by a structural steel test fixture. The graphite-epoxy stabilizer assembly (test article) was attached to a metal production center section at the front- and rear-spar inboard terminal lug locations. A dummy right-hand stabilizer box was attached to the right-hand side of the center section and was used for symmetrical loading. The center section was supported by a structural test fixture at its aft support hinges and front dummy jackscrew fitting. The test setup is shown in Figure 1.

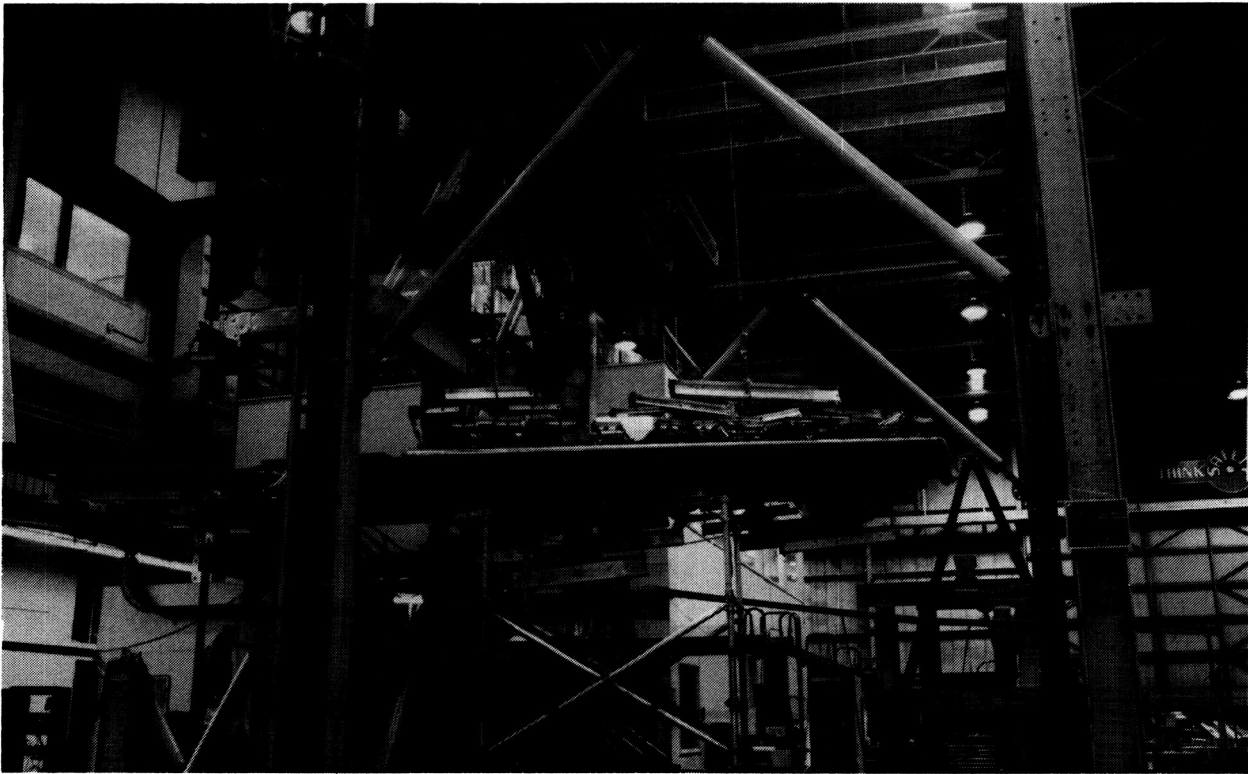

Figure 1. Test Setup—Full-Scale Ground Test

Stabilizer air loads were applied to the lower and upper surface through pads bonded to the surface panels (fig. 1). The stabilizer inspar section, trailing-edge, and elevator surface areas were divided into sector areas with a load pad or fitting for each sector. Pad loads were applied through a series of eveners systems and hydraulic actuators. The load pad locations and pad load distributions were

optimized to match spanwise shear, moment, and torsion for each load case tested. Required leading-edge and balance panel loads matched shear and torsion about the front spar and elevator hinge line respectively. Sixteen hydraulic jacks were used to apply the tension and compression pad loads, leading-edge loads, and balance panel loads. A load cell was installed in series with each hydraulic jack to measure applied load. Rosette strain gages (195) and axial strain gages (62) were installed to measure strains at critical areas and to verify internal load distributions. Structural deflections were measured at 18 locations along the front and rear spars by electronic deflection indicators (EDI).

The composite stabilizer was subjected to five static load cases (LC):

- Load case 5: positive maneuver at 648 km/hr (350 kn) at 7163m (23 500 ft) (maximum torsion, damage tolerance tests)
- Load case 3710: positive maneuver at 814 km/hr (440 kn) at 3018m (9900 ft) (maximum torsion, ultimate load tests)
- Load case 4430: positive gust at 518 km/hr (280 kn) at sea level (maximum positive bending)
- Load case 4761: negative gust at 814 km/hr (440 kn) at 3962m (13 000 ft) (maximum negative bending and surface pressure, ultimate load test)
- Load case 4010: flaps down maneuver at 352 km/hr (190 kn) at sea level (maximum negative bending)

The stabilizer was successfully tested to 67% of design ultimate load for load cases 3710, 4010, 4761, and 4430 with no damage to the specimen. Strain, deflection, and load readings were recorded. Examination of measured strains and deflections showed agreement with the finite element ATLAS model values. After the limit load test, the stabilizer was subjected to spectrum loads equivalent to 120 000 flights representing one-and-one-half lifetimes of aircraft service. Spectrum loads equivalent to 40 000 flights were applied to an undamaged stabilizer. Damage was then inflicted to simulate service and/or maintenance damage to the stabilizer in the areas shown in Figure 2. A detailed description of the damage is in Reference 1. With the damage present, the stabilizer was subjected to spectrum loads equivalent to 80 000 flights. Strain and deflection surveys were conducted before application of cyclic loads. Similar surveys were conducted again for each block of 20 000 flights of cyclic loads applied. The respective measured strain and deflection values were in close agreement at each survey.

Visual inspections were conducted of all accessible structure at scheduled intervals during testing. Ultrasonic inspections were made of critical areas at less frequent intervals, and X-ray inspections were performed before and after application of cyclic loads with the inflicted damage present. No structural damage or flaw growth of areas with inflicted damage were found during any inspection. Upon completion of the repeated load tests, residual strength with the induced damage (fig. 2) was tested. The test article withstood application of limit load for load cases 4010, 4430, and 5 with the induced damage.

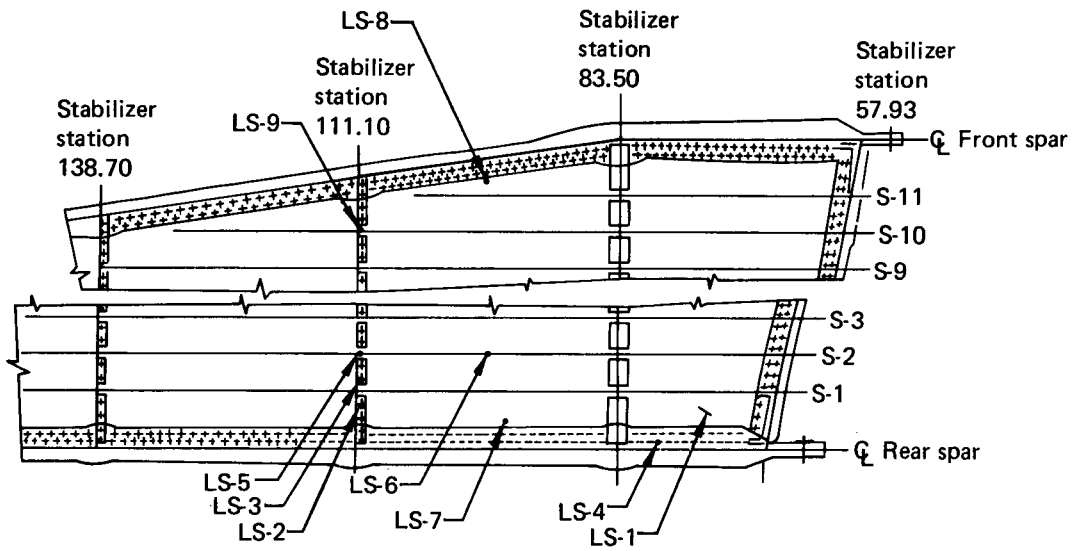

Lower Surface Damage Location

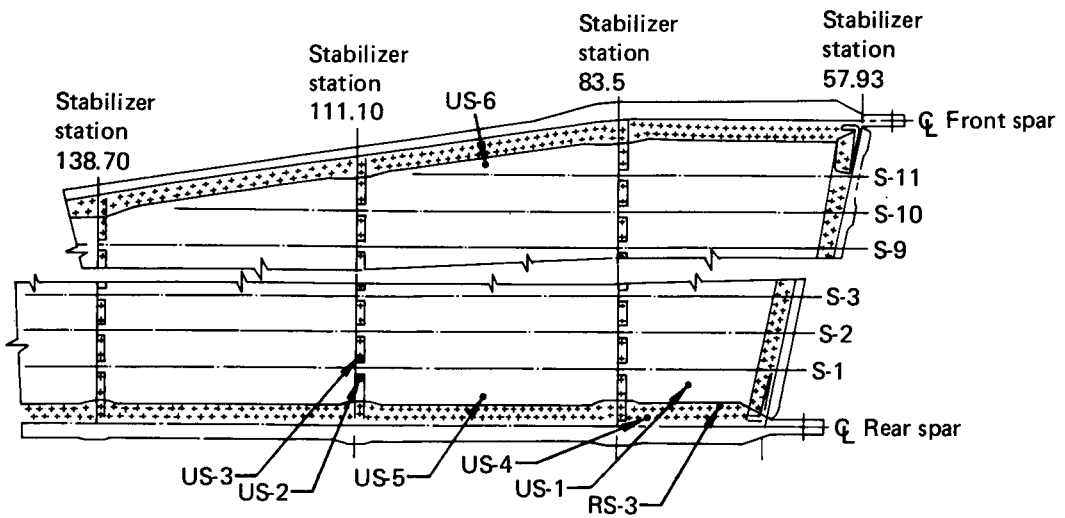

Upper Surface Damage Location

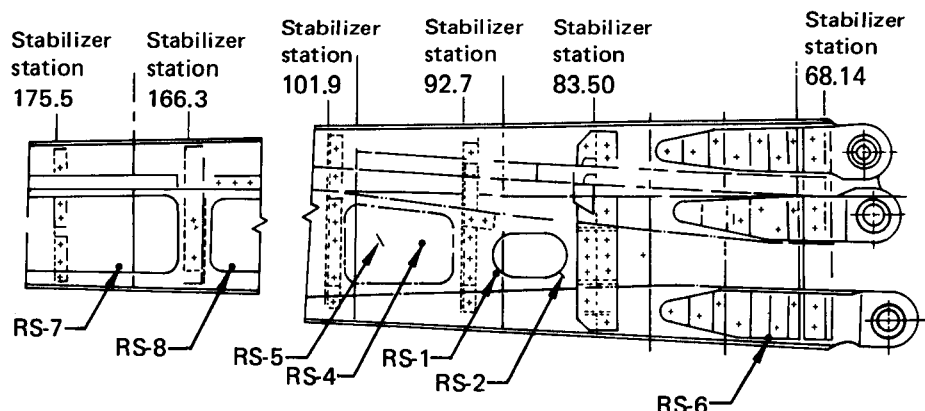

Rear Spar Damage Location

Figure 2. Induced Damage Locations

The stabilizer was loaded to 100% design ultimate load for load cases 3710 and 4430 with no damage or failures occurring. At 94.4% of design ultimate load for load case 4761, test loading was halted when graphite fiber breakage occurred to the rear-spar upper terminal lug. Graphite fiber breakage at this load level was predicted by component tests. The design includes lug reinforcement to sustain ultimate loads with the graphite damaged. No repair was made to the rear-spar lug, and load case 4761 was applied to 100% of design ultimate load without further damage. Finally, ultimate load case 4010 was applied to 100% of design ultimate load, and no additional damage occurred. Strain, deflection, and load readings were recorded for all ultimate load cases. Examination of measured strains and deflections showed agreement with the finite element ATLAS model values.

Fail-safe tests, simulating failed spar-to-center-section attachment points, were performed by removing one of the spar attachment pins or bolts and applying the critical design limit load as a fail-safe load. The stabilizer was successfully tested to 100% of design limit load for load case 4430 with the front-spar lower bolt removed; for load case 4430 with the rear-spar lower pin removed, and for load case 4010 with the front-spar upper bolt removed. During application of load case 4010 with the rear-spar upper pin removed, a shear failure of the rear-spar web between stabilizer stations 68.14 and 96.0 occurred at 61% of design ultimate load (91% of design limit load). The rear-spar failure was initiated by a tension failure of graphite-epoxy fibers in a direct line between the upper fail-safe lug and the lower lug. The failure is shown in Figure 3. This area was fixed by the addition of a steel reinforcement plate integral with the fail-safe lug strap, the lower lug strap, and the spar web (the integrity was proved by analysis).

At the conclusion of all ground testing, the stabilizer was subjected to lightning strike tests. Results are shown in Figures 4 and 5.

The full-scale test program met all certification goals, and the required data were submitted to the FAA.

3.2 GROUND VIBRATION TEST

Ground vibration testing was performed on a production 737 aircraft with a graphite-epoxy horizontal stabilizer installed. The purpose of the test was to measure the natural frequencies and modes of the graphite-epoxy stabilizer/elevator/tab. These frequencies and modes were compared with those used in the flutter analysis.

The test airplane was positioned on a level surface in an operating-empty weight configuration. The airplane was supported on the main and nose gears with reduced tire pressure. A portable vibration shaker was used to excite the stabilizer at several locations and directions. Tests were conducted with hydraulic power on and off. The test setup is shown in Figure 6.

Accelerometers, located on both right- and left-hand stabilizers, elevators, tabs, and control columns, were used to measure control system natural frequencies, mode shapes, and damping characteristics. In addition, accelerometer data were recorded on the fin/rudder, wingtip, and stabilizer support structure. The measured natural frequencies of the graphite-epoxy stabilizer were in close agreement with those of the aluminum stabilizer, demonstrating similar dynamic

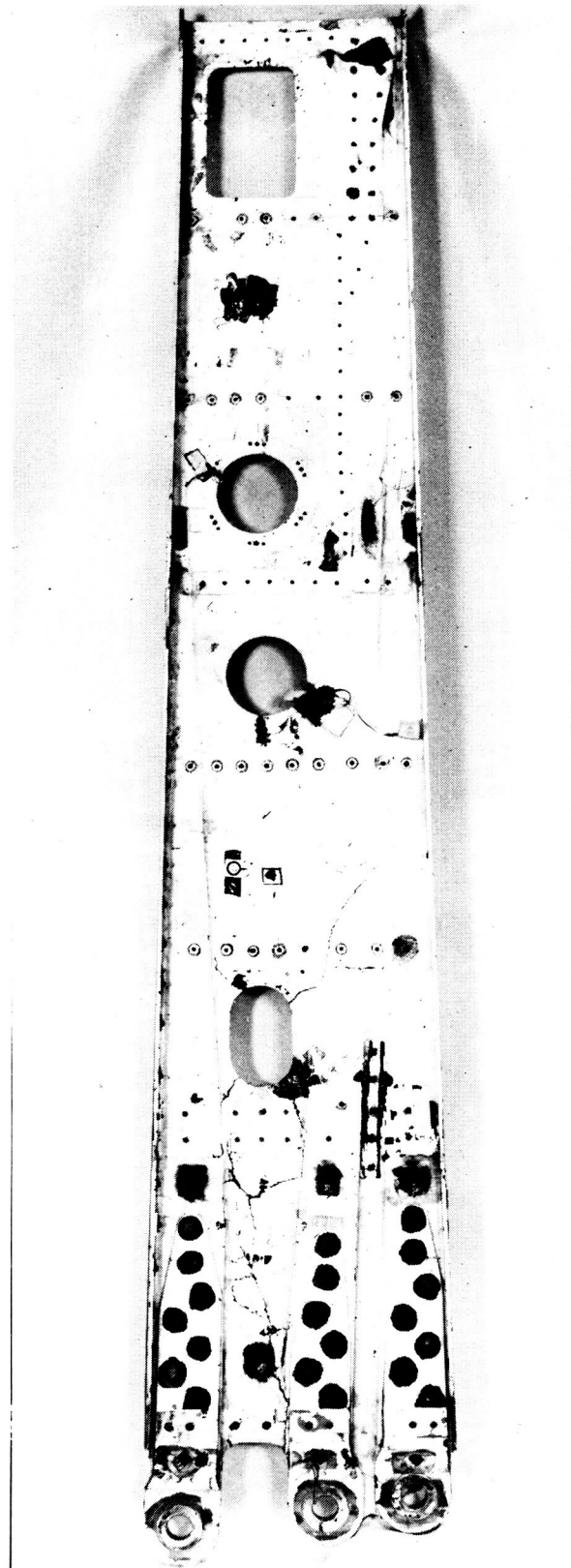

Figure 3. Rear-Spar Failure—Load Case 4010 With Upper Pin Removed

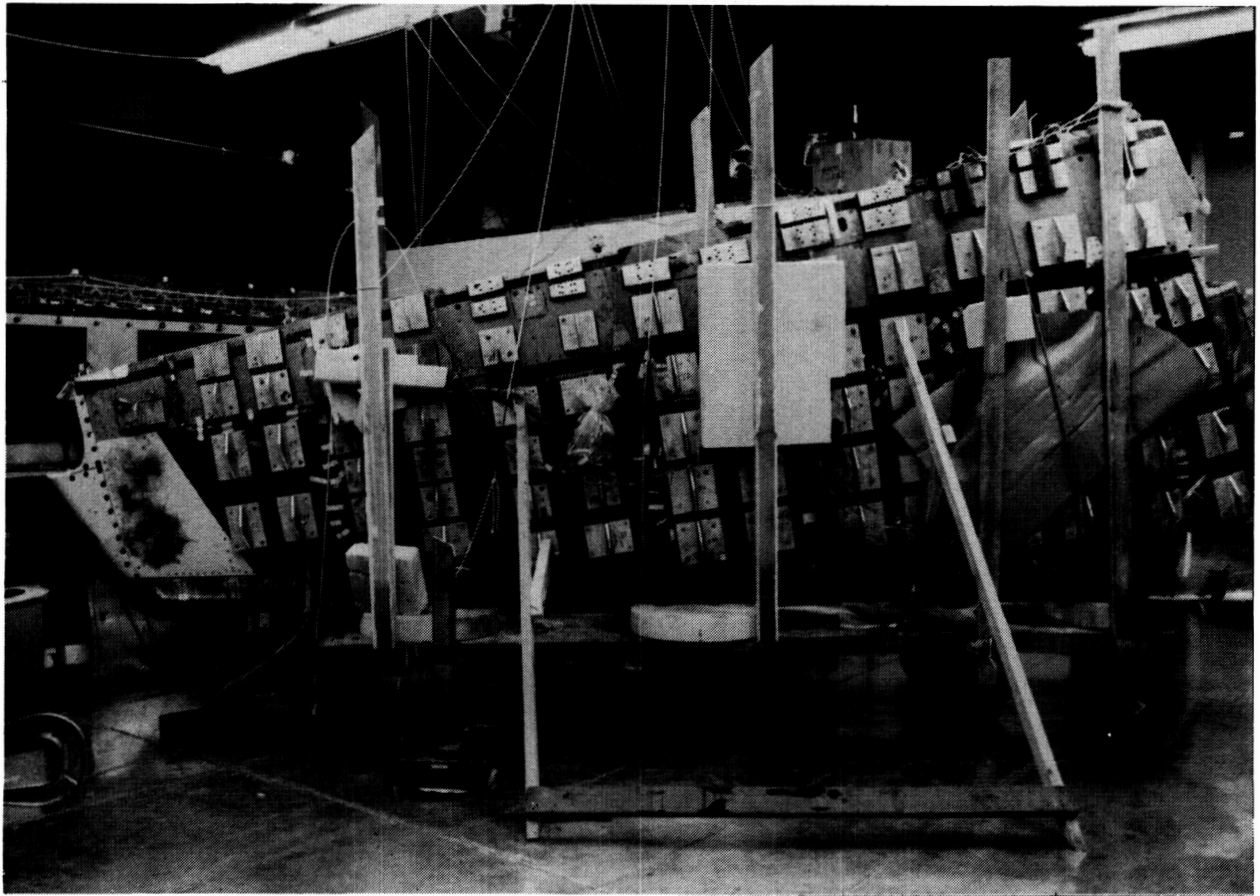

Figure 4. Lightning Strike Test

characteristics. A mode comparison of the aluminum and graphite-epoxy structures is shown on Table 1.

3.3 FLIGHT TESTS

Flight tests were conducted to demonstrate flutter clearance and stability and control performance. The flight flutter test used a production model 737-200 with a graphite-epoxy horizontal stabilizer installed.

The airplane was flown at incrementally increasing speeds up to the airplane dive speed at three altitudes. The envelope of conditions flown is shown in Figure 7. Excitation of the stabilizer was performed by control surface impulses and an oscillating aerodynamic vane mounted on the left-hand stabilizer tip. The vane installation is shown in Figure 8. At each speed, subcritical damping and frequency calculations were made from measurements taken on the empennage. Control system power on and off, autopilot, and yaw damper operation were checked. Modal damping for all modes was high throughout the tests.

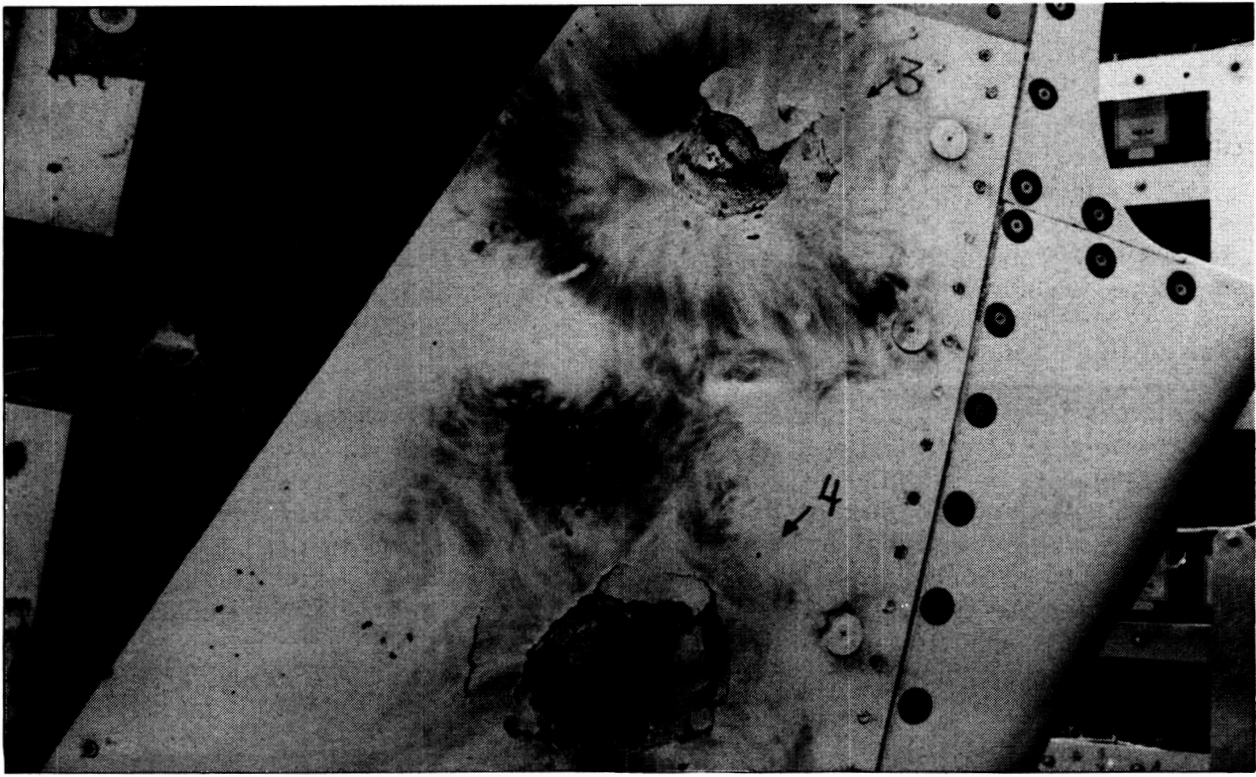
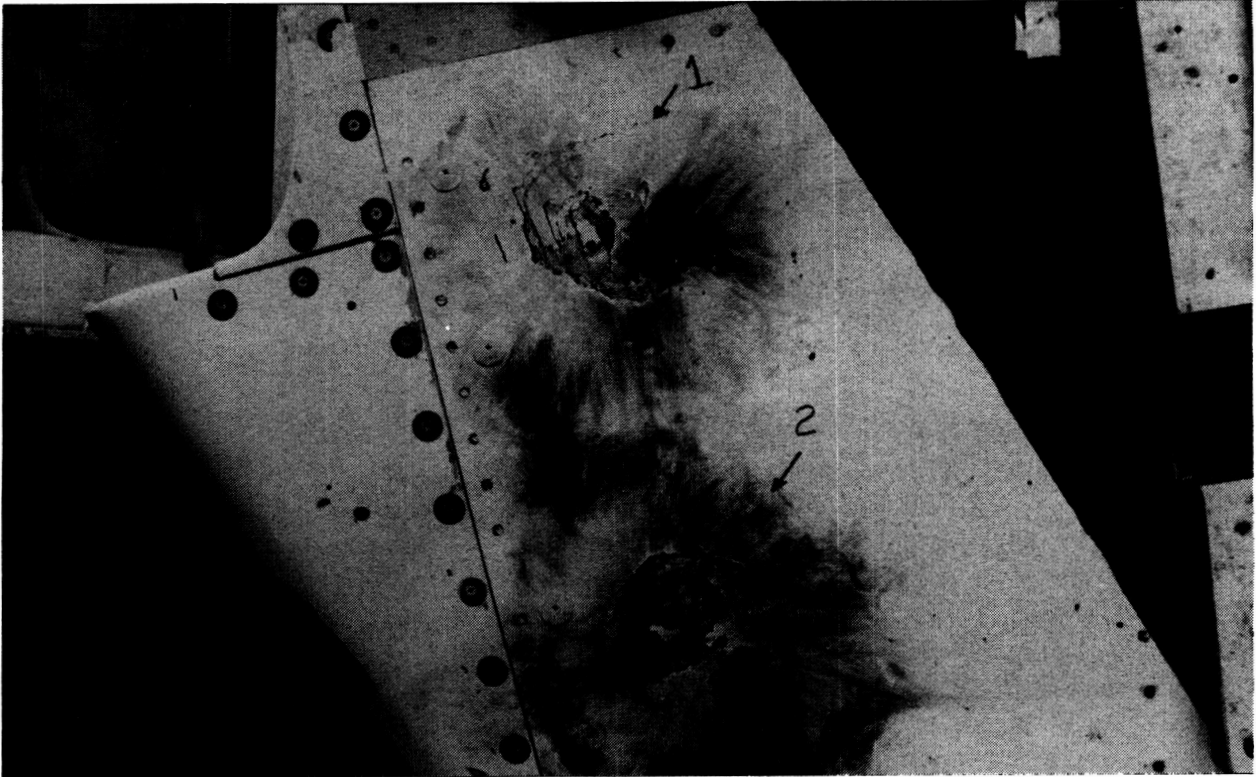

Figure 5. Lightning Strike Test

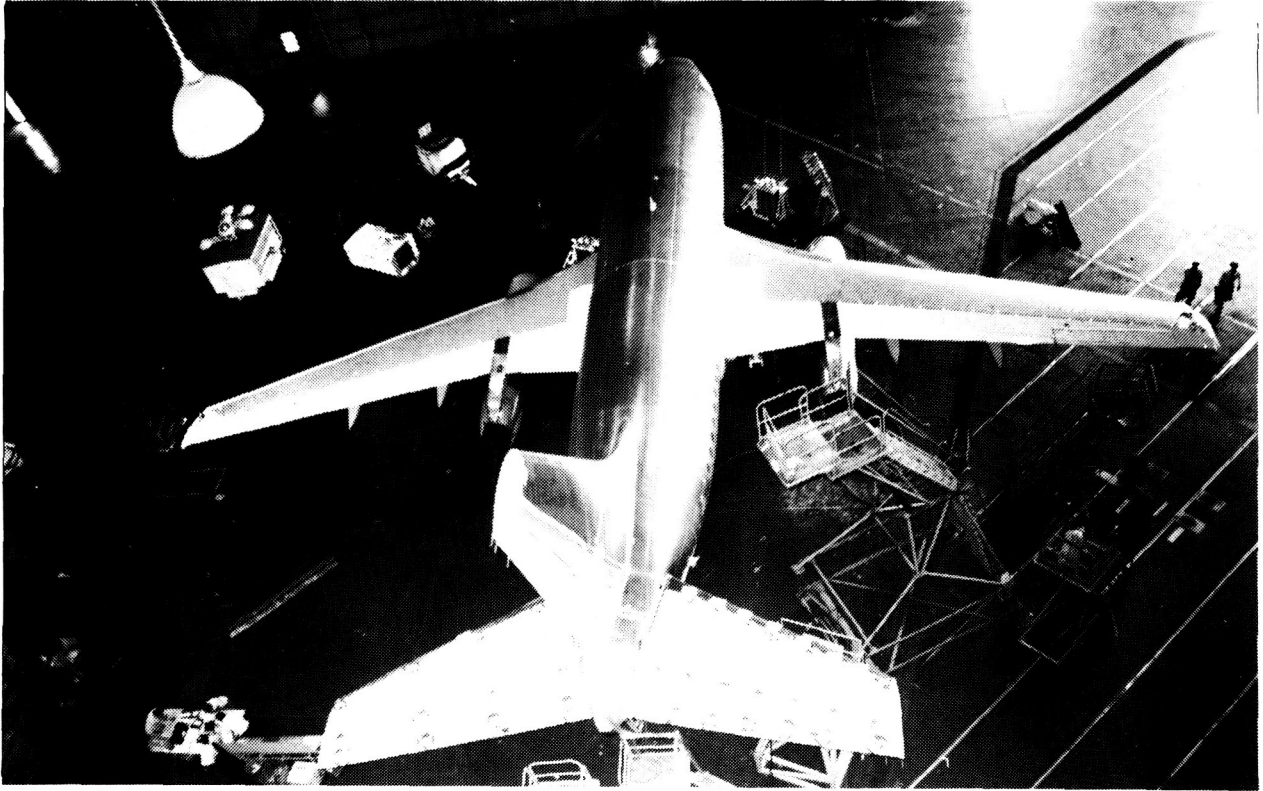

Figure 6. Ground Vibration Test Setup

Results of this testing with the graphite-epoxy stabilizer have demonstrated clearance to the V_D/M_D flight boundary and an equivalence to the aluminum stabilizer from a flutter standpoint.

Stability and control flight tests consisted of two phases. Phase I flight tests were conducted on a production aluminum stabilizer to establish baseline data. For phase II, the aluminum stabilizer was replaced by the graphite-epoxy stabilizer, and phase I flight tests were repeated.

Flight test maneuvers that placed the highest demands on the longitudinal control system were selected. These maneuvers, which were flown with both the aluminum and graphite-epoxy stabilizers for back-to-back comparison, included windup turns with hydraulic power on and off, stabilizer-elevator trades, mistrim dive recoveries, and simulated landings in manual reversion. In addition to the back-to-back testing, selected certification maneuvers also were flown to demonstrate further that the graphite-epoxy stabilizer produces no change in 737 handling characteristics. These certification maneuvers included flaps up and flaps 40 stall characteristics and longitudinal static stability in cruise at 9144m (30 000 ft) and 7010m (23 000 ft). The flight test airplane was flown by an FAA pilot as part of the stability and control and autopilot certification flight testing. Back-to-back flight test conditions demonstrate that there are no significant differences in observed flight characteristics when the aluminum stabilizer is replaced by the graphite-epoxy stabilizer. Flight test results show that the graphite-epoxy

Table 1. Aluminum Versus Graphite-Epoxy Stabilizer Mode Comparison

Mode description	Hydraulic power on		Hydraulic power off	
	Composite frequency, Hz	Aluminum frequency, Hz	Composite frequency, Hz	Aluminum frequency, Hz
Body lateral bending/torsion stabilizer spanwise bending	4.23 A	4.23	4.26 A	4.24
Stabilizer spanwise bending	5.66 A	5.70	5.69 A	5.57
Elevator rotation	5.94 A	5.99	5.97 A	5.97
Stabilizer bending/ elevator rotation	6.73 S	6.72	6.62	
Stabilizer spanwise bending	6.98 S	7.01	7.12	
Stabilizer chordwise bending	7.28 A	7.62	Not measured	Not measured
Elevator torsion	18.42 A		18.50 A	
Stabilizer chord/pitch	19.23 S	18.18	Not measured	Not measured
Elevator torsion	19.76 S	20.32	19.81 S	20.28
Stabilizer 2nd bending/torsion	24.53 A	24.78	24.80 A	

Note: A is antisymmetric; S is symmetric.

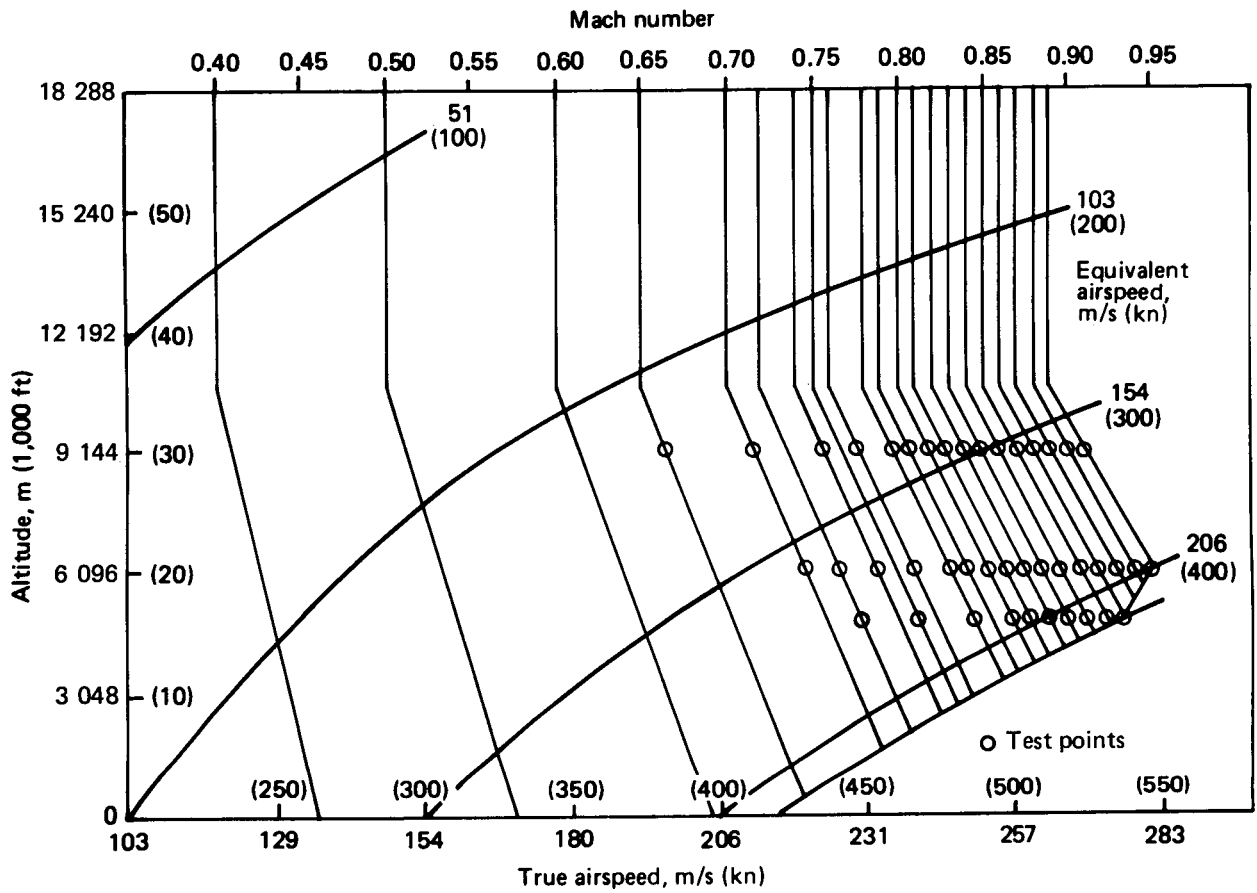

Figure 7. Speed and Altitude Test Points

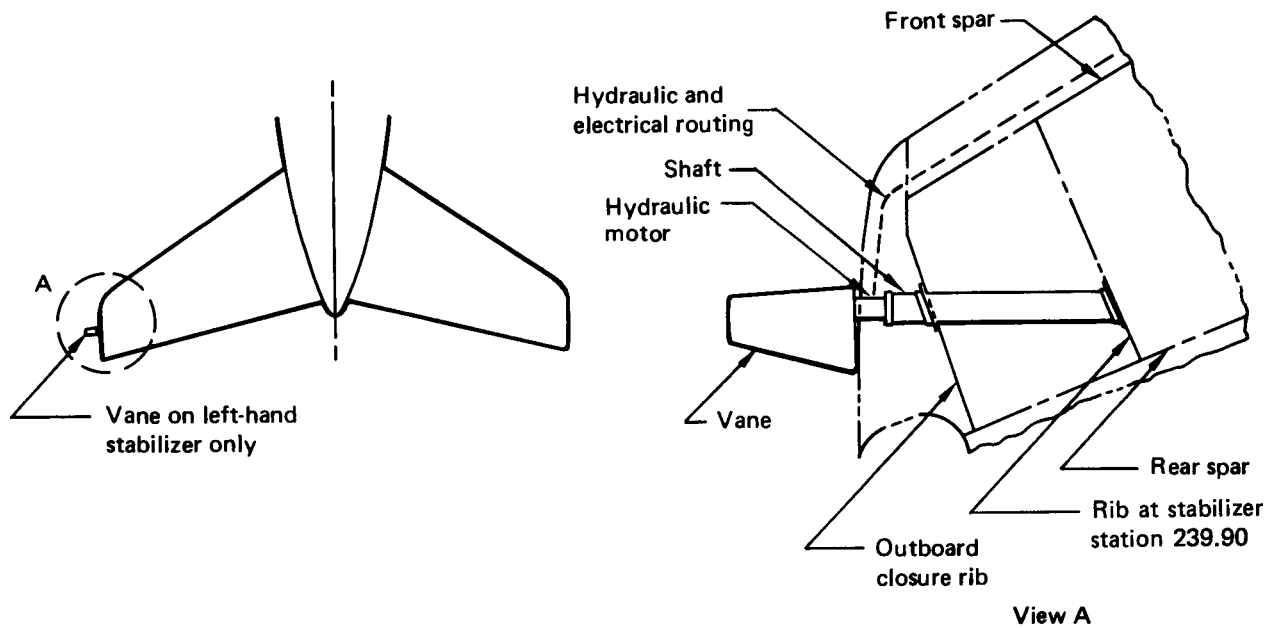

Figure 8. Flutter Vane Installation

stabilizer is equivalent to the aluminum stabilizer and, therefore, will satisfy all handling qualities requirements of Federal Aviation Regulation 25 (FAR 25) for the model 737.

3.4 FAA CERTIFICATION

FAA certification was achieved by showing compliance with the requirements of FAR 25 and Composite Guidelines AC 20-107.

Compliance was demonstrated by structural analyses and supporting test evidence. The test program that produced the supporting data included a full-scale ground test, a flight test program, and an ancillary test program, all discussed in previous sections of this document and in References 2 and 3. Structural analyses included a finite element model analysis (ATLAS), an ultimate strength analysis, and a damage tolerance and fail-safe analysis. These analyses and supporting test data were submitted to and accepted by the FAA. Certification of the 737 graphite-epoxy horizontal stabilizer was issued in the third quarter of 1982.

3.5 WEIGHTS

Weights were calculated based on production drawing configurations. The new weight values were used to replace the evaluations derived during the preliminary analysis stage. Completion of production calculations resulted in a weight increase of 9.7 kg (21.1 lb) over the preliminary values.

The predicted total weight of the graphite-epoxy inspar structure following this revision was 183.3 kg (404.1 lb) compared with the aluminum structure weight of 238.3 kg (525.4 lb), a reduction of 23%.

Reevaluation of production drawings and design changes incorporated through the program resulted in a final predicted weight of 187.1 kg (412.6 lb) and a weight reduction of 21.5% as shown in Table 2.

Because of the assembly sequence for the horizontal stabilizer, it was not possible to weigh the inspar structure alone. Therefore, graphite-epoxy components weighed under an actual weight program were tabulated to the appropriate shipset and compared with the calculated values. This tabulation (table 3) shows an average weight increase of 1.4% over the predicted values.

Table 2. Metal and Graphite-Epoxy Horizontal Stabilizers—
Inspar Structure Weight Comparison

Item	Baseline aluminum stabilizer structure, kg (lb)/airplane		Advanced composite stabilizer structure, kg (lb)/airplane		Weight difference, kg (lb)/airplane		Weight difference, %
Front spar	31.3	(69.0)	21.2	(46.8)	-10.1	(-22.2)	-32.2
Rear spar	71.1	(156.8)	51.6	(113.7)	-19.5	(-43.1)	-27.5
Skins							
• Upper	36.2	(79.8)	39.0	(86.0)	+2.8	(+6.2)	+7.8
• Lower	36.2	(79.8)	40.2	(88.7)	+4.0	(+8.9)	+11.2
Ribs	60.9	(134.2)	34.1	(75.2)	-26.8	(-59.0)	-44.0
Corrosion protection	—	—	1.0	(2.2)	+1.0	(+2.2)	—
Lightning protection	—	—	0.0	(0.0)	—	—	—
Access doors	0.7	(1.6)	0.0	(0.0)	-0.7	(-1.6)	-100.0
Gap cover support	1.9	(4.2)	0.0	(0.0)	-1.9	(-4.2)	-100.0
Total stabilizer inspar structure per airplane	238.3	(525.4)	187.1	(412.6)	-51.2	(-112.8)	-21.5
Stabilizer TE/elevator interface thermal expansion provision	—	—	15.5	—	+15.5	—	—

1 1.0 lb included in skin panel weight.

2 Gap cover support structure integral design of inboard closure rib installation.

Table 3. Predicted and Actual Composite Stabilizer Inspar Structure Component Weights

Component	Predicted values	Actual weights per shipset									
		No. 1		No. 2		No. 3		No. 4		No. 5	
		LH	RH	LH	RH	LH	RH	LH	RH	LH	RH
Front spar, kg (lb)	9.8 (21.5)	9.7 (21.3)	9.8 (21.6)	9.8 (21.5)	9.8 (21.6)	9.9 (21.8)	9.8 (21.6)	10.1 (22.2)	10.8 (23.7)	10.0 (22.1)	10.0 (22.0)
Rear spar, kg (lb)	22.3 (49.3)	22.5 (49.5)	21.9 (48.2)	22.6 (49.9)	22.4 (49.4)	22.6 (49.9)	22.9 (50.4)	22.5 (49.5)	22.6 (49.9)	22.7 (50.0)	22.6 (49.9)
Skin panel—upper, kg (lb)	17.8 (39.3)	17.8 (39.2)	17.9 (39.5)	18.1 (40.0)	18.4 (40.6)	17.6 (38.9)	17.6 (38.9)	17.4 (38.4)	17.6 (38.9)	17.7 (39.0)	18.2 (40.2)
Skin panel—lower, kg (lb)	18.8 (41.4)	19.1 (42.1)	19.1 (42.2)	19.3 (42.6)	19.4 (42.7)	19.0 (41.8)	19.3 (42.5)	19.0 (41.8)	19.0 (41.8)	19.0 (41.8)	19.3 (42.5)
Rib details, kg (lb)	9.3 (20.5)	9.6 (21.1)	9.6 (21.2)	9.9 (21.9)	9.6 (21.1)	9.5 (21.0)	9.7 (21.4)	9.9 (21.8)	9.4 (20.8)	9.8 (21.6)	9.8 (21.6)
Totals, kg (lb)	78.0 (172.0)	78.7 (173.2)	78.3 (172.7)	79.9 (175.9)	79.6 (175.4)	78.6 (173.4)	79.3 (174.8)	78.9 (173.7)	79.4 (175.2)	79.2 (174.6)	79.9 (176.2)
Difference, %	—	+0.7	+0.4	+2.3	+2.0	+0.8	+1.6	+1.0	+1.9	+1.5	+2.4

4.0 PRODUCTION

Production experience was a prime objective of the advanced composite stabilizer program. Five-and-one-half shipsets, each consisting of a left-hand segment and opposite right-hand segment, were manufactured with advanced composite materials. Experience was gained in:

- Estimating (cost and schedule)
- Tool development (detail and assembly)
- Fabrication processes (detail and assembly)

The stabilizer assembly is a hybrid assembly of graphite and aluminum components. The graphite portion consisted of 280 part numbers produced by Boeing's Fabrication Division in Auburn, Washington. The graphite fabrication was accomplished according to a Boeing process specification that uses the method for no-bleed material. Of the 280 part numbers, 15 were major graphite assemblies that included:

- Upper and lower skin panel
- Front and rear spar
- Trailing-edge beam
- Seven inspar ribs and a lightning strike support rib
- Outboard and inboard closure rib

The 268 metal components and the assembly work were accomplished at the Boeing facility in Wichita, Kansas, because of their commonality with the model 737 production. Work activity was divided into nine major assembly positions:

- Front and rear spar
- Rear-spar and trailing-edge join
- Stabilizer major assembly
- Stabilizer mill and bore
- Stabilizer floor pickup
- Seal
- Paint and shipping preparation

Each segment weighed approximately 175.5 kg (386 lb) and required approximately 700 assembly labor hours. The average flow time per shipset was 77 days from the start of the first position until it was ready for shipment.

4.1 DETAIL TOOLS

Detail tools were fabricated from aluminum, steel, and fiberglass using conventional tool fabrication design and fabrication practices. Male tooling was the most common because of reduced cost both in fabrication and part layup. Female tools had minimal use. Where possible, the tooling was developed to produce opposite parts on the same mandrel. Shrink factors had to be added to the tooling material to account for thermal expansion during the 182°C (350°F) cure cycle.

4.2 ASSEMBLY TOOLS

Assembly tooling was conventional. The assembly fixture for building the entire stabilizer assembly was a new tool. The production model 737 tool could not be used because the graphite assembly had fewer parts and other variances. Only the production rear-spar/trailing-edge join tool was used in common with the graphite program. The capability to vacuum the dust during drilling and trimming operations was a unique feature added to the tools.

4.3 OVERALL PRODUCTION

Overall production problems were minimal. Some of the prevalent problems were:

- Warpage. This was a considerable concern in the fabrication of the skin panels and spars. With minimal pressure during the assembly phase, however, the warpage was relieved and caused no assembly problem.
- Delamination. This was a problem in two incidents. One caused a change to the process procedure, and the other was a workmanship error that caused contamination of the layup tool when a wrong liquid was used.
- Resin-starved areas. These areas on the surface of some parts caused a redesign.
- Interference. Some interference problems between the old metal trailing-edge section and the graphite had to be relieved by redesign.
- The "Bigfoot" blind fastener used on the closure skin panel had to be changed to reduce the time required to microshave the pin. On the latter units with unidirectional tape-finished skins, special effort was taken to reduce or eliminate hole breakout on the exterior surface at the drill exit point.

5.0 COST ANALYSIS

It is projected that advanced composite material waste will be reduced with the implementation of advanced manufacturing technology and more uniform quality material. Based on this projection, the production experience gained during this program, and assumptions of other cost-reducing factors detailed in Section 5.3, the cost of advanced composite stabilizers will become comparable to the cost of similar metal components.

When the increasing value of weight reduction is considered together with the adoption of innovative manufacturing methods and engineering designs, the economic justification for advanced composite aircraft structure is ensured.

This section presents the production cost data for the five-and-one-half-shipset production run.

5.1 PRODUCTION COSTS

5.1.1 Production Environment

Tooling and component manufacturing percentages shown in Figure 9 are relative to overall costs in dollars; engineering costs are not included. The total production program costs shown in Figure 10 reflect the fabrication and manufacturing processes used in a semiproduction environment for the five-and-one-half-shipset program.

Work was performed in production shops by employees whose experience and skill level represented a cross section of the shop work force. Component fabrication was performed with hand cutting and layup of broadgoods, ply-by-ply inspection, and hand trimming. Tooling was designed for extended production, but the tool rework and improvement effort was restricted to the five-and-one-half-shipset contract.

These activities represented the production processes that would, when practical, be used to produce a large number of stabilizers. It is likely, however, that by adopting improved manufacturing processes, the per-unit cost of stabilizers produced in a regular production environment would be significantly lower. Projections of production cost trends are discussed in Section 5.3.

5.1.2 Total Costs

Of the total production expenditures for the five-and-one-half shipsets, labor was 85% and nonlabor was 15%. The major cost elements of the total production labor costs are shown as percentages in Figure 10. The component production labor hours shown in Figure 10 are: fabrication, 64%, assembly, 30%, and manufacturing research and development (MR&D), 6%. Total production labor hours are presented in Figure 11 showing the breakout between recurring (67%) and nonrecurring (33%) costs. Many nongraphite parts used in the composite stabilizer are common to both the metal and the composite stabilizer. Some of these had to be modified from the configuration provided by the part vendor or metal stabilizer subcontractor to make them usable in the composite stabilizer assembly. Recurring fabrication and assembly efforts are broken out by task and presented in Figures 12 and 13.

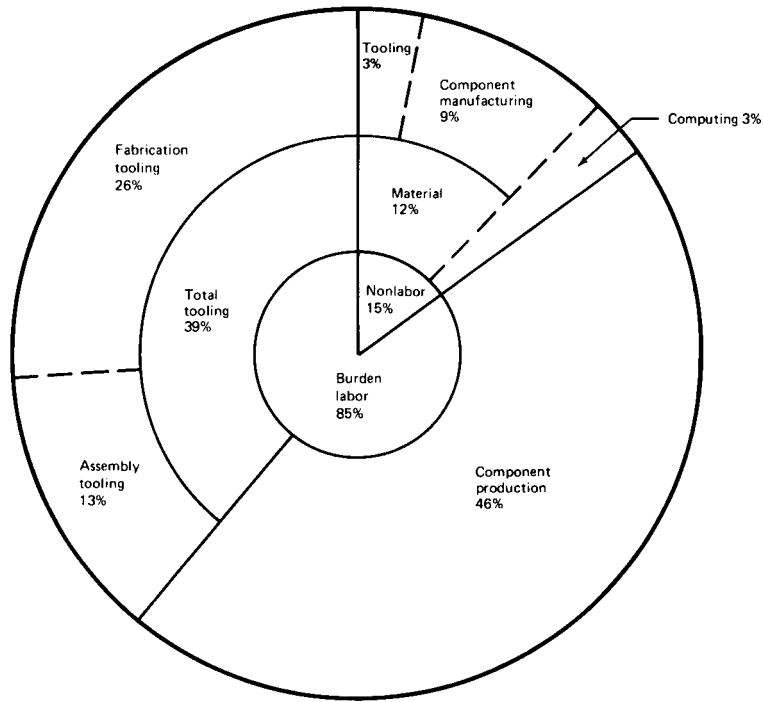

Figure 9. Total Recurring and Nonrecurring Production Costs by Major Element—5½ Shipsets

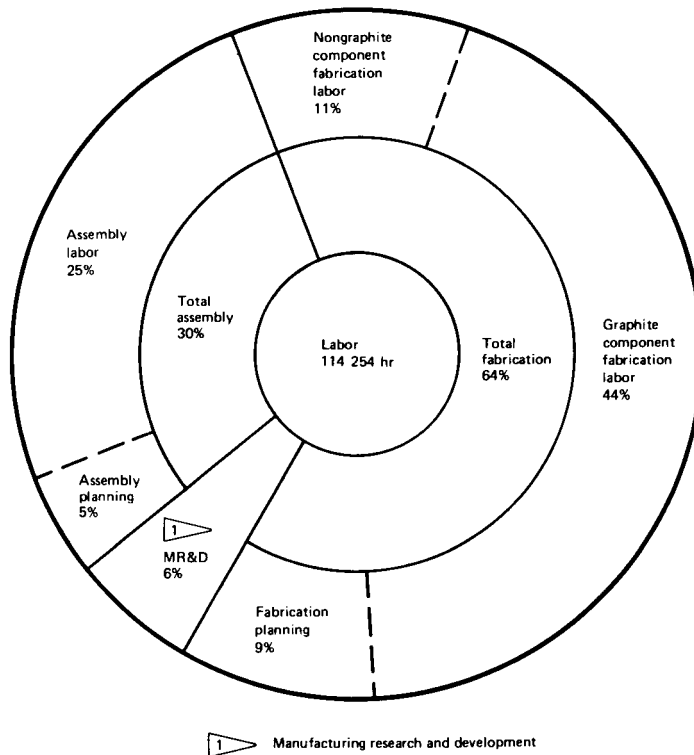

Figure 10. Total Recurring and Nonrecurring Component Production Labor Hours—5½ Shipsets

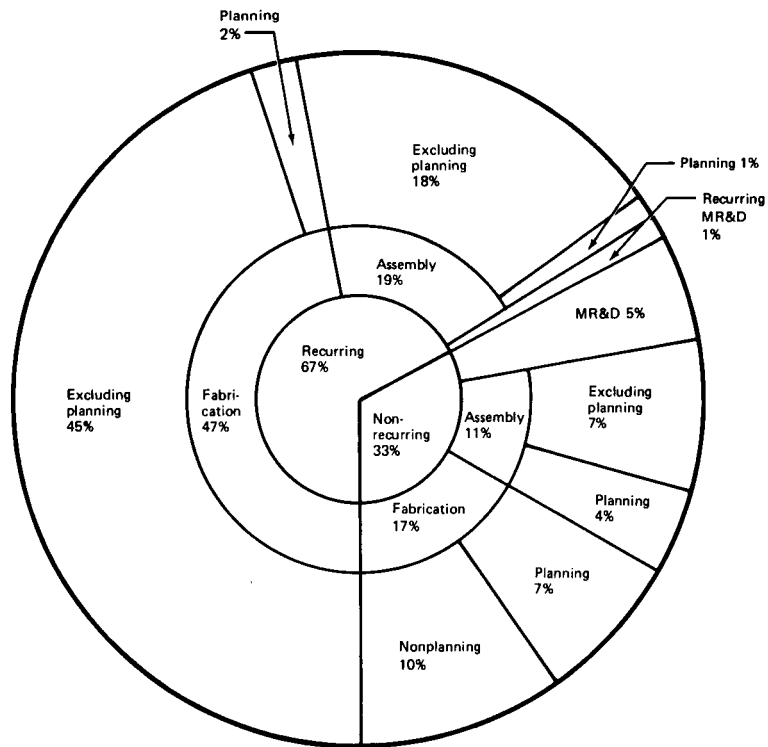

Figure 11. Total Recurring and Nonrecurring Production Labor Hours (Excludes Tooling and Engineering)

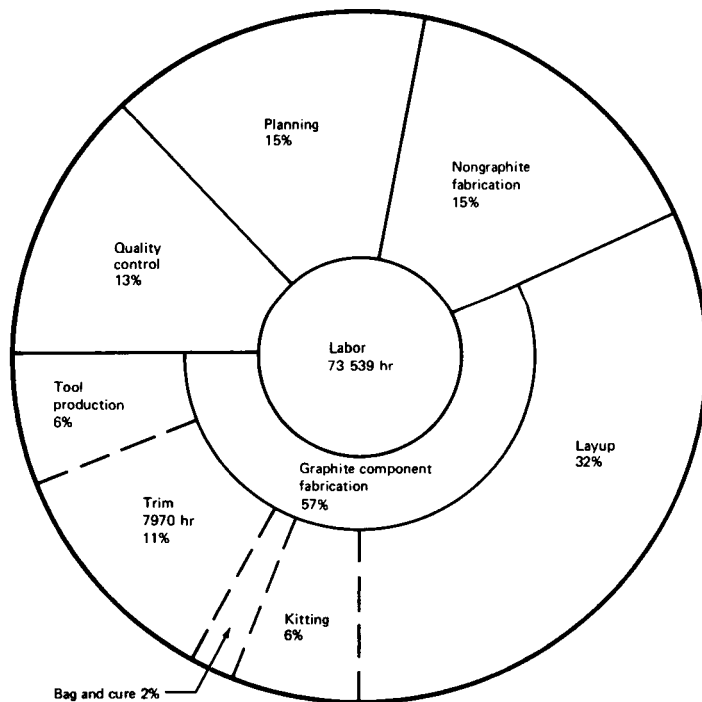

Figure 12. Total Recurring and Nonrecurring Fabrication Hours—5½ Shipsets

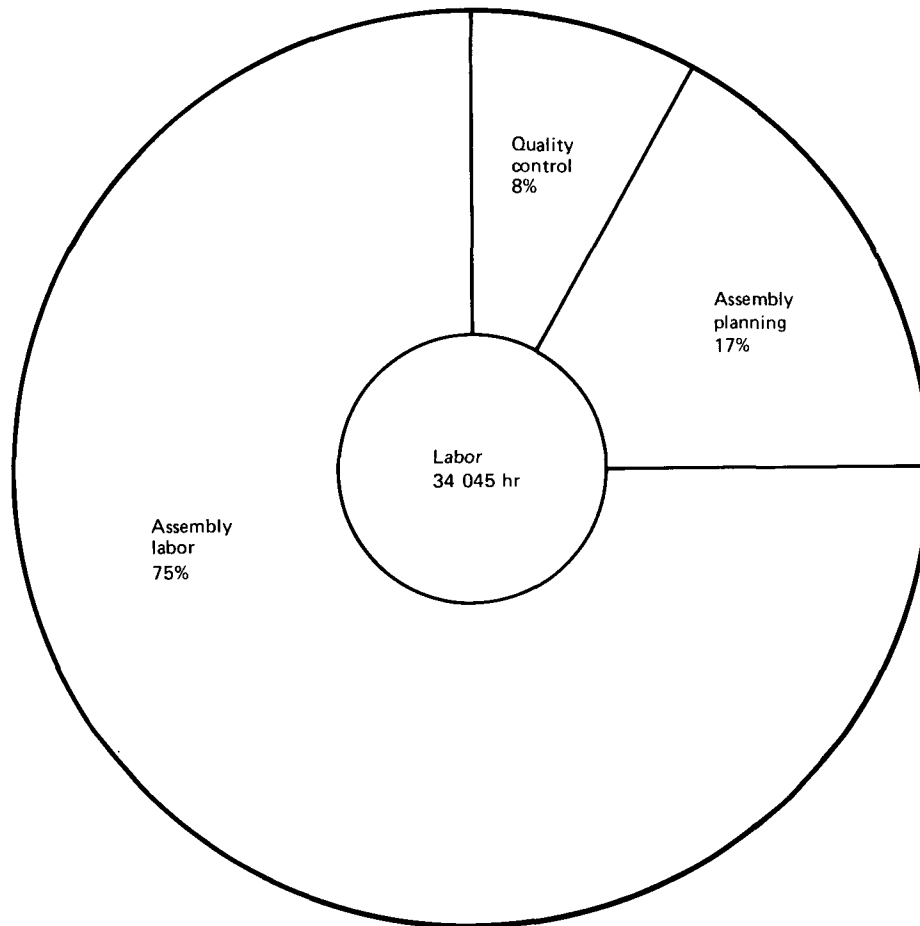

Figure 13. Total Recurring and Nonrecurring Assembly Labor Hours—5½ Shipsets

5.2 COMPOSITE MATERIAL USAGE FACTORS

Usage factors experienced for graphite-epoxy materials were 0.78 kg (1.8 lb) of tape and 1.22 kg (2.8 lb) of fabric for each pound of graphite-epoxy flyaway weight in the finished stabilizer. This included indirect usage for receiving tests, kitting trim loss, process test panels, process and miscellaneous rejections, and layup trim loss. It is estimated that these factors could be reduced to 1.5 and 2.0 lb, respectively, over a 200-shipset program with more uniform quality materials, revised handling methods, and improved manufacturing processes. With automated material cutting/part nesting and new layup and processing technology, these factors would be further reduced.

5.3 COST COMPARISONS

Based on costs incurred in producing the five-and-one-half shipsets of the composite stabilizer, recurring costs for 200 shipsets are estimated at \$40.3 million, using

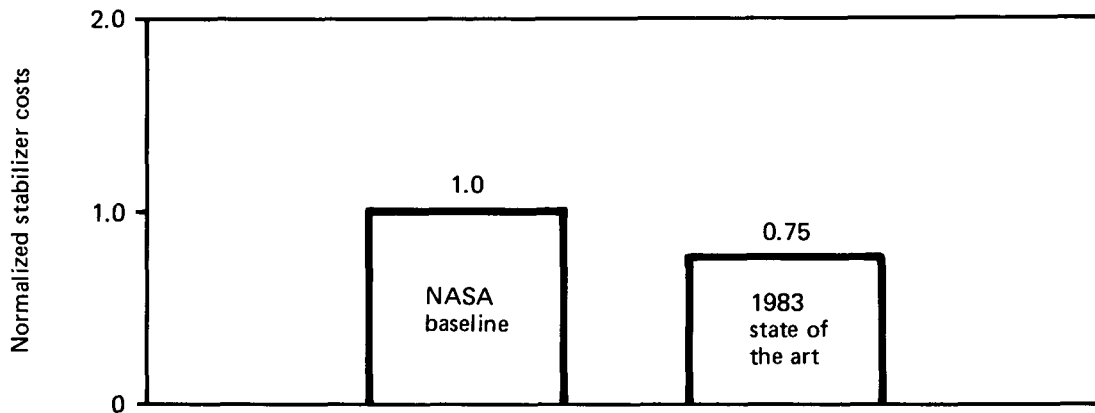

Figure 14. Relative Composite Stabilizer Cost Comparison—Initial 200 Shipsets

the NASA baseline. This figure is derived from \$32.9 million in labor and \$7.4 million in material.

The effect of improved technology on the trend of competitive cost averages for the initial 200-shipset quantities of the model 737 composite stabilizer is depicted in Figure 14. This figure shows that the present costs could be reduced by 25% with improved automated methods. Further optimization of the design would be expected to produce additional cost benefits.

Ground rules for the cost projection of 200 shipsets of the composite stabilizers shown in Figure 14 are based on:

- Cost projection is the scoping level.
- Costs are recurring only for 200 shipsets.
- Costs reflect 1981 commercial pricing rates and do not include profit or contingency.
- Part count and weights are assumed to be the same as the NASA stabilizer.
- Auburn and Wichita labor hour estimates have been adjusted to reflect 1983 state of the art.
 - MR&D has defined 1983 state of the art to include automated tape laminators, automated ply cutters, vacuum compacting tables, improved fasteners, and laminated shims.
 - Designs will be revised as required to allow automated manufacturing methods.
- Graphite material costs are based on supplier quotations.
- Graphite-epoxy usage factors: tape 1.5 lb, fabric 2.0 lb.
- Automation will radically change the ratio of tape versus fabric in the design.

6.0 CONCLUSIONS

NASA established a program for primary composite structures under the Aircraft Energy Efficiency (ACEE) program. As part of this program, Boeing has redesigned and fabricated the horizontal stabilizer of the 737 transport using composite materials. Five shipsets were fabricated, and FAA certification has been obtained. Airline introduction will follow.



Key program results are:

- Weight reduction greater than the 20% goal has been achieved.
- Parts and assemblies were readily produced on production-type tooling.
- Quality assurance methods were demonstrated.
- Repair methods were developed and demonstrated.
- Strength and stiffness analytical methods were substantiated by comparison with test results.
- Cost data were accumulated in a semiproduction environment.
- FAA certification has been obtained.

The program has provided the necessary confidence for the company to commit use of composite structure in similar applications on new generation aircraft and has laid the groundwork for design of larger, more heavily loaded composite primary structure.

7.0 REFERENCES

1. Aniversario, R. B.; Harvey, S. T.; McCarty, J. E.; Parsons, J. T.; Peterson, D. C.; Pritchett, L. D.; Wilson, D. R.; and Wogulis, E. R.: Full-Scale Testing, Production, and Cost Analysis Data for the Advanced Composite Stabilizer for Boeing 737 Aircraft. Volume II—Final Report. NASA CR-166012, December 1982.
2. Aniversario, R. B.; Harvey, S. T.; McCarty, J. E.; Parsons, J. T.; Peterson, D. C.; Pritchett, L. D.; Wilson, D. R.; and Wogulis, E. R.: Design, Ancillary Testing, Analysis, and Fabrication Data for the Advanced Composite Stabilizer for Boeing 737 Aircraft. Volume I—Technical Summary. NASA CR-3648, 1983.
3. Aniversario, R. B.; Harvey, S. T.; McCarty, J. E.; Parsons, J. T.; Peterson, D. C.; Pritchett, L. D.; Wilson, D. R.; and Wogulis, E. R.: Design, Ancillary Testing, Analysis, and Fabrication Data for the Advanced Composite Stabilizer for Boeing 737 Aircraft. Volume II—Final Report. NASA CR-166011, December 1982.
4. Federal Aviation Regulations, Part 25, Airworthiness Standards: Transport Category Airplanes. Department of Transportation, Federal Aviation Administration, December 1978.

1. Report No. NASA CR-3649		2. Government Accession No.		3. Recipient's Catalog No.	
4. Title and Subtitle FULL-SCALE TESTING, PRODUCTION, AND COST ANALYSIS DATA FOR THE ADVANCED COMPOSITE STABILIZER FOR BOEING 737 AIRCRAFT. VOLUME I - TECHNICAL SUMMARY				5. Report Date April 1983	
				6. Performing Organization Code	
7. Author(s) R.B. Aniversario, S.T. Harvey, J.E. McCarty, J.T. Parsons, D.C. Peterson, L.D. Pritchett, D.R. Wilson, and E.R. Wogulis				8. Performing Organization Report No. D6-46038-1	
9. Performing Organization Name and Address Boeing Commercial Airplane Company P.O. Box 3707 Seattle, Washington 98124				10. Work Unit No.	
				11. Contract or Grant No. NAS1-15025	
				13. Type of Report and Period Covered Contractor Report	
12. Sponsoring Agency Name and Address National Aeronautics and Space Administration Washington, D.C. 20546				14. Sponsoring Agency Code	
15. Supplementary Notes Langley Technical Monitor: A.J. Chapman Final Report					
16. Abstract This report defines and discusses the development, testing, production activities, and associated costs that were required to produce five-and-one-half advanced-composite stabilizer shipsets for Boeing 737 aircraft.					
17. Key Words (Suggested by Author(s)) advanced composites long-term durability structural integrity weight savings				18. Distribution Statement  	
19. Security Classif. (of this report) Unclassified		20. Security Classif. (of this page) Unclassified		21. No. of Pages 40	22. Price