

N85-20457

39

MEASUREMENTS OF PARTIAL REFLECTIONS AT 3.18 MHz  
USING THE CW-RADAR TECHNIQUE

J. Priese and W. Singer

Academy of Sciences of the GDR  
Central Institute of Solar-Terrestrial Physics  
(Heinrich Hertz Institute)  
DDR-1199 Berlin, GDR

An equipment for measuring partial reflections using the FM-CW-radar principle at 3.18 MHz, recently installed at the Ionospheric Observatory Juliusruh of the CISTP (HHI), is described. The linear FM-chirp of 325 kHz bandwidth is Gaussian-weighted in amplitude and gives a height resolution of 1.5 km (chirp length is 0.6 sec). Preliminary results are presented for the first observation period in winter 1982/83.

INTRODUCTION

A partial reflection experiment was put into operation in December 1982 at Juliusruh (geographic coordinate 54.63°N, 13.38°E, L = 2.62) and is firstly applied to study different D-region parameters such as electron density, height of reflecting layers, and fading periods. This method gives an important enlargement of the well-known groundbased methods such as A1/A3-absorption measurements, indirect phase-height measurements and meteor-wind observations, which are being used in our Institute for diagnostics and monitoring of the mesosphere and lower thermosphere.

INSTRUMENTATION

The functional scheme of the transceiver equipment is given in Figure 1. The chirp signal is generated by an ultra-linear VCO, the frequency ripples of which being smaller than 300 Hz over the whole sweep width (further parameters are listed in Figure 2). High linearity is obtained by matched forming of the controlling voltage following a power series of third order in time (KALASS, 1977; KALASS et al., 1981).

The envelope of the signal amplitude is frequency weighted by Gaussian band-pass-filters in both directions of transmitting and of receiving; the 3 dB-band widths being 66.4 kHz. The Gaussian filters designed by TIMPL (1979, 1980) approximate the ideal Gauss-envelope with ripples smaller 0.2 dB down to -70 dB (the ends of the truncated chirp). The filters are realized by band-passes of 14th order.

The amplified signal is transmitted by an array consisting of 4 x 4 horizontal orthogonal pairs of half-wave dipoles installed approximately  $\lambda/8$  above the dissipative ground ( $n = 30 + j 170$ ); the dipoles of each pair being crossed with a distance of 1 m. A gain of 16.5 dB (for one polarization) referred to the isotropic radiator has been obtained by using the computed values of the attached Sommerfeld-problem (PRIESE and SCHNEIDERHEINZE, 1983) together with the measured current distribution as well as the resulting radiation resistance of each dipole (PRIESE, 1980, 1981). The beam-widths (27° in the E-plane, 28.5° in H-plane) have been measured by means of a helicopter (PRIESE, 1981). The orthogonal arrays are excited in phase quadrature and opposite polarization are obtained by reversing one of the feed systems.

The receiving array is separated about 4 wavelengths from the transmitting antenna and consists of 2 x 2 orthogonal pairs of resonant loops. The sum signal will be amplified by 40 dB in an amplifier of low intermodulation

ORIGINAL PAGE IS  
OF POOR QUALITY

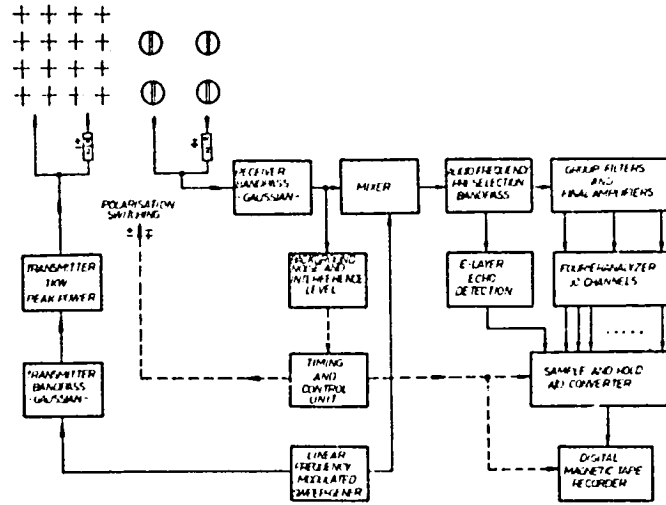

Figure 1. Functional scheme of the transceiver equipment.

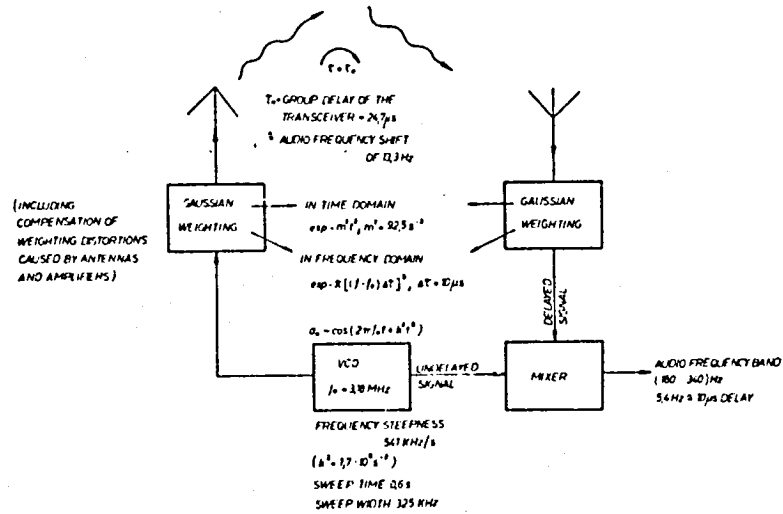

Figure 2. Signal diagram.

distort: (for the first observation period a half-wave dipole could be used only). After mixing of the undelayed with the reflected and therefore delayed signal, the audio frequency components of the mixer spectrum contains the information of height and amplitude of the partial reflection. Following the introduction to chirp theory by KLAUDER et al. (1960) it is well known that an unweighted chirp-process results in an audio frequency spectrum with range-sidelobes of the  $\sin x/x$ -type. A sidelobe-compression is absolutely necessary in order to avoid confusion of the spectra of the partial reflection levels among one another as well as to suppress the sidelobe spectra of the strong E-layer reflection and the mutual coupling between the antennas respectively.

Following a first idea of KLAUDER et al. (1960), Keiser introduced Gaussian weighting as a rigorous method to reduce the sidelobes, and prepared the basic parameters of chirp, filters and transceiver (see reports by BREMER et al., 1973; KALASS et al., 1981). Furthermore, the chirp process results in the important compression gain of the signal compared with a constant-frequency pulse of the same envelope. Power gain  $N$  and delay resolution  $\tau$  are given for an infinite chirp by

$$N = \sqrt{\pi/m} \cdot \Delta\tau, \quad \Delta\tau = \sqrt{\pi} \cdot m/K^2.$$

Based on the desired values of  $\tau = 10 \mu\text{s}$  (corresponding to a height resolution of 1.5 km) and a compression gain of  $N = 43 \text{ dB}$  the signal processing parameters shown in Figure 2 have been derived. Additional efforts have been made to study the effects of sweep truncation as well as of phase and amplitude distortions of the chirp (KALASS et al., 1981).

Last not least, the audio frequency spectrum of a detached partial reflection level is obtained (after some omissions) in the form

$$A_{\text{out}}(f) \sim \exp\left\{-\frac{\pi}{2} \left[N\Delta\tau f - \frac{\tau}{\Delta\tau}\right]^2\right\} = \exp\left\{-\frac{\pi}{2} \left[\frac{f}{5.4 \text{ Hz}} - \frac{\tau}{10 \mu\text{s}}\right]^2\right\}$$

The 3.4 dB width of this spectrum is about 5.4 Hz, so the Fourier-analyzer must have the same frequency resolution and is hardware realized by active low-pass filters of 2.7 Hz bandwidth (KALASS, 1977) following the outputs of the quadrature demodulators. The spectrum of each sweep is analyzed for 30 height channels from 47.5 km to 91 km with a stepsize of 1.5 km. The A/D converter has a resolution of 11 bits. For each sweep the amplitude height profile is recorded on magnetic tape. The data reduction will later be done on an all-purpose KRS 4200 computer.

The equipment has two different modes of operation. In the continuous mode sweeps are transmitted with a repetition frequency of 1.25 Hz, in the intermittent mode 10 consecutive sweeps are emitted at the beginning of each minute. In both modes it is possible to observe either with a fixed polarization (ordinary or extraordinary) or with polarization switching.

#### PRELIMINARY RESULTS

Data have been evaluated for days with high radio wave absorption (winter anomaly) and low absorption in December 1982 and January 1983 to investigate the variability of electron density in winter. For winter anomaly conditions the data of December 24, 1982 and January 12, 1983 are presented. On these days, A3-absorption values on 3 measuring paths exceeded the monthly median value by about 4 to 8 dB and A1-absorption values in the MF-range (2 MHz) by about 6 dB. As example for conditions of low absorption the data of December 27, 1982 and January 21, 1983 are used, when LF-absorption was about 5 dB and MF-absorption about 3 dB below the monthly median (all data for solar zenith angle  $\chi = 78.5^\circ$ ).

In Figure 3, time averaged height profiles (median values) of the amplitudes of the ordinary (o)- and extraordinary (x)-mode are shown for the days mentioned above. The height profiles are smoothed by running averages over 3 successive values. For low absorption the  $A_x$ -height profiles exceed the noise level above 74.5 km and attain a maximum at about 80 km (on Jan. 21 the noise level was enhanced by two times). For winter anomaly conditions, signals exceeded the noise level already at lower heights (on Dec. 24 at 70 km; on Jan. 12 at 67 km). In the height profiles maxima occur on Dec. 24 at 79 km and on Jan. 12 at 76 km. By analysis of the autocorrelation functions for continuous measurements with fixed polarizations, the half-amplitude widths of the autocorrelation functions were found of the order of seconds, increasing with decreasing heights.

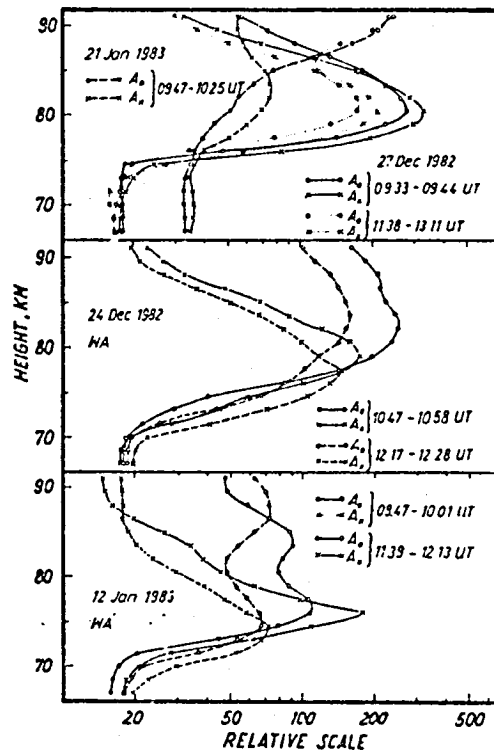

Figure 3. Averaged amplitude profiles of the extraordinary and ordinary component (WA: day with winter anomaly in absorption).

The basic theory for the differential-absorption experiment was given by GARDNER and PAWSEY (1953), modified by BELROSE and BURKE (1964), assuming that observations of weak echoes of high frequency radio waves scattered from the lower ionosphere are caused by Fresnel reflection from discontinuities in the refractive index. Following these papers, the height distribution of electron density has been derived from the observed ratio  $A_x/A_o$  of the backscattered amplitudes of the extraordinary and ordinary magneto-ionic components using the

improved quasi-longitudinal approximation to the exact Sen-Wyller expression of the refractive index after FLOOD (1980). The height profile of monoenergetic collision frequency is assumed as  $\nu_m = 7.5 \times 10^3 \times p$ , the pressure data being taken from CIRA 72 including seasonal variations.

In Figure 4 the derived electron density profiles (solar zenith angles about  $78^\circ$ ) are shown for the data of Figure 3. Noise correction has been performed for the amplitude data by using the noise in the height range 55 to 60 km, where no ionospheric signals are expected. At the upper end of the derived profiles, the electron density values are uncertain by a factor of about 1.5 due to the low signal-to-noise ratio of the extraordinary component.

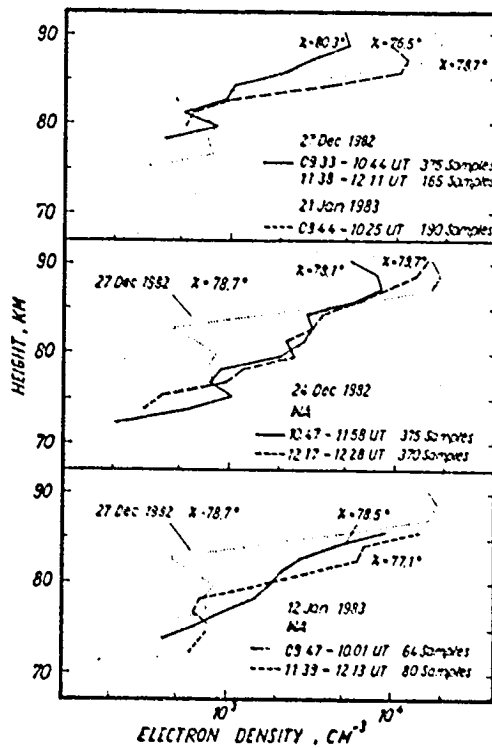

Figure 4. Electron-density profiles for winter conditions using the amplitude data of Figure 3 (WA: day with winter anomaly).

A comparison between the electron density profiles evaluated for high absorption conditions with the profiles derived for low absorption shows a marked increase in electron density between 76 and 85 km in the presence of winter anomaly.

#### CONCLUDING REMARKS

A few examples of preliminary results have been presented, obtained by a new partial reflection equipment using the CW-radar principle during winter

1982/83. For the four days evaluated here it was possible to derive electron density profiles in the height range 72 to 90 km. Under winter anomaly conditions the electron density profiles show a marked increase between 76 and 85 km by a factor of about 2 to 6 compared to days without winter anomaly.

To check the reliability of the derived profiles it will be of interest to compare the observed absorption values in the LF- and MF-range with the theoretical calculated absorption values for these electron density profiles. Before the forthcoming summer observation period the provisional receiving antenna will be replaced by the designed receiving array. In future it is planned to implement a partial reflection drift equipment.

#### REFERENCES

- Belrose, J. S., M. J. Burke (1964), *J. Geophys. Res.*, 69, 2799.  
 Bremer, J., J. Keiser, J. Prieese, W. Singer, J. Taubenheim and E. Weiss (1973), Unpublished report, Central Institute of Solar-Terrestrial Physics, Berlin-Adlershof, GDR.  
 Flood, W. A. (1980), *Radio Sci.*, 15, 797.  
 Gardner, F. F. and J. F. Pawsey (1953), *J. Atmos. Terr. Phys.*, 3, 321.  
 Kalass, D. (1977), Thesis, Hochschule für Verkehrswesen "Friedrich List", Dresden (unpublished).  
 Kalass, D., J. Keiser, A. Himalski, J. Prieese, W. Singer, J.-G. Stangenberg, H. Timpl and W. Vietzke (1981), Unpublished report, Central Institute of Solar-Terrestrial Physics, Berlin-Adlershof, GDR.  
 Klauder, J. R., A. C. Price, S. Darlington and W. J. Albersheim (1960), *Bell System Technical Journal*, 39, 745.  
 Prieese, J. (1980), GDR-Patent WP H01 Q/198373.  
 Prieese, J. (1981), *Nachrichtentechnik/Elektronik*, 31, 372.  
 Prieese, J. and G. Schneiderheinze (1983), NHI-STP Report (in press), Central Institute of Solar-Terrestrial Physics, Berlin-Adlershof, GDR.  
 Timpl, H. (1979), *Nachrichtentechnik/Elektronik*, 29, 188, 283, 458.  
 Timpl, H. (1980), GDR-Patent WP H03 H/206263.

