

(NASA-TM-86006) NASA AMES SUMMER HIGH
SCHOOL APPRENTICESHIP RESEARCH PROGRAM
(NASA) 108 p HC A06/MF A01 CSCI 051

N85-26590
THRU
N85-26609
Unclas
21108

G3/99

NASA AMES SUMMER HIGH SCHOOL APPRENTICESHIP RESEARCH PROGRAM

JUNE 16 — AUGUST 17, 1984



April 1985

NASA

National Aeronautics and
Space Administration

NASA Ames Summer High School Apprenticeship Research Program June 16 — August 17, 1984

STUDENT PAPERS

Coordinated by Patricia Powell, Ames Research Center, Moffett Field, California

April 1985



National Aeronautics and
Space Administration

Ames Research Center
Moffett Field, California 94035

TABLE OF CONTENTS

	Page
INTRODUCTION.....	1
ACKNOWLEDGMENTS.....	3
LACK OF COMMUNICATION..... James Aguilar	5
PRIMATE EXPERIMENTS ON SLS-1..... Julie Aochi	9
IS THERE MORE THAN ONE STEADY STATE FOR NOx?..... George Bakas	15
THE PHYSICAL EFFECTS OF DIFFERENT STRESS SITUATIONS ON GRAPHITE/EPOXY COMPOUNDS... Derrick Brazill	21
HARRIER..... Sean Caffee	31
VOYAGE TO URANUS..... Mindy Dalrymple	35
A BRIEF DESCRIPTION OF THE TWO PRIMATE EXPERIMENTS TO BE CARRIED OUT ON SL-4..... Louise Elsea	41
THIN ROUTE PROJECT..... S. Gregory Felix	47
WHAT IS BEING DONE TO CONTROL MOTION SICKNESS?..... Yvette D. Hall	53
COMMUNICATIONS..... Sadie Hathorn	59
GALILEO..... Cynthia Hwang	63
AIRCRAFT SAFETY IMPROVEMENT..... Gloria Kao	69
THE CONTROLLED ECOLOGICAL LIFE SUPPORT SYSTEM..... Kenneth Ko	77

CONTROLLED ECOLOGICAL LIFE SUPPORT SYSTEMS (CELSS).....	81
Mousumi Majumdar	
YAV-8B HARRIER.....	89
Daniel Ornelas	
PROGRAMMING FOR PIONEER 12.....	93
Bruce C. Shem	
CARDIOVASCULAR EFFECTS OF WEIGHTLESSNESS.....	99
Kendra Short	
ROTORCRAFT DIGITAL ADVANCED AVIONICS SYSTEM (RODAAS).....	105
Brent Taira	
THE SEARCH FOR EXTRATERRESTRIAL INTELLIGENCE.....	109
Ann Tucher	



ORIGINAL PAGE
BLACK AND WHITE PHOTOGRAPH

Seated: James Aguilar.
Bottom Row: (l to r) Patricia Powell, SHARP Faculty Coordinator, Kendra Short, Melinda Dalrymple, Sadie Hathorn, Derrick Brazill, Gloria Kao, Mousumi Majumdar.
Second Row: Jeanette Remington, Employee Development Specialist, George Bakas, Julie Aochi, Brent Taira, Cynthia Hwang, Daniel Ornelas, Louise Elsea, Kenneth Ko.
Top Row: Sukie Stanley, Chief, Training and Special Programs Branch, Gregory Felix, Sean Caffee, Bruce Shem, Yvette Hall, Alton Wong.
Not Shown: Ann Tucher.

INTRODUCTION

Engineering enrollments are rising in universities; however, the graduate engineer shortage continues. Particularly, women and minorities will be underrepresented for years to come. As one means of solving this shortage, federal agencies facing future scientific and technological challenges were asked to participate in the Summer High School Apprenticeship Research Program (SHARP). This program was created 5 years ago to provide an engineering experience for gifted female and minority high school students at an age when they could still make career and education decisions.

The SHARP Program is designed for high school juniors (women and minorities) who are United States citizens, are 16 years old, and who have unusually high promise in mathematics and science through outstanding academic performance in high school. Students who are accepted into this summer program will earn as they learn by working 8 hours a day in a 5-day work week. This work-study program features weekly field trips, lectures and written reports, and job experience related to the student's career interests.

The experience of SHARP '84 will be long remembered by the fortunate high school students who worked with the team of mentors from many different branches here at Ames Research Center. Some of the spirit of excitement and challenge of the students and the dedication of the scientist-mentors has been captured in this volume and in the following comments from some of the students.

"Before I started work in the Extraterrestrial Research Division, I feared that I would be spending all my time investigating recent U.F.O. sightings, but to my delight the work is far more practical and meaningful."

"Getting a job with NASA has taught me a lot, from how to fight rush-hour traffic to all the thinking that goes into the selection of a good (or should I say edible) cafeteria lunch. But most of all, it cleared up many of the wrong ideas I had about work. This is important because I feel that it is better to have a belief destroyed by a truth than to continue believing in a misconception."

"After working at Ames for 3 weeks, I have found my position of assistant in the engineering lab in Flight Simulations Branch to be both exciting and enlightening. I have learned many new electronic techniques regarding wire organization and placement."

"So far my experience working at Ames Research Center has been very rewarding and informative. I enjoy working in the engineering lab in the Flight Simulations Branch. Although I have learned a lot by working on projects, I have gained the most knowledge by talking to the engineers and technicians."

"Besides doing some computer programming, I also am learning how to use EDT, a method of editing on the VAX/VMS computer, whenever I have any spare time. Through working with the Pascal programs, and the computer, I was also able to gain

knowledge of the commands in FORTRAN and in computer-generated graphics. The fact that I have been given so much responsibility so soon makes me feel like I am really part of the lab."

"Throughout my time, my relatives have jokingly inquired if I was going up with the Shuttle. I always give them a relieved 'No,' for I am personally frightened of such a prospect and grateful that I have the opportunity to work here; because this job will provide experience, contacts, and open doors that would otherwise remain firmly shut."

"While Dr. Wharton has allowed me to get involved and get a thorough understanding of this project and his experiments, he has also given me the independence to pursue my own interests."

"So far my job has led me from the private library located on the NASA Ames facility to the CSSI and VARD simulators. I have been treated as an intelligent and responsible employee and not as a mere 'teenager.' I have also been allowed to explore, learn, and become involved with our nation's space program by taking part in many of my group's previous and current studies which play a major role in space travel."

ACKNOWLEDGMENTS

Few programs of research exploration have provided such rewards of the depth and insight as the Summer High School Apprenticeship Research Program (SHARP). Those high school students who were fortunate enough to be with the team of mentors here at Ames Research Center will long remember the experience. Some of the spirit of excitement and challenge is captured in this paper.

The 1984 NASA Ames Summer High School Apprenticeship Research Program (SHARP) student trainees are grateful to the many staff members at Ames Research Center, Moffett Field, California, who made this historic summer of scientific exploration and research possible. They took time from their busy schedules to offer assistance, information, and encouragement to 20 SHARP student trainees. A special expression of thanks goes to each Ames Research Center scientist or engineer (mentor) who worked on a daily basis with his/her assigned SHARP student trainee.

We acknowledge with appreciation the support given by the Equal Opportunity Programs Office, Graphics and Exhibits Branch, Photographic Technology Branch, Personnel Management Branch, Public Affairs Office, Publications Office, Records and Reports Branch, Security Branch, and the Training and Special Programs Branch.

Special recognition must be given to all the staff members at NASA Headquarters in Washington, D.C. for the birth of this program and the work they did to transform SHARP from an idea into a reality. We particularly want to mention Curtis Graves, and Doris Grigsby for their dedicated service on the national level. We value highly the efforts of Les Jackson, Manager of SHARP "84" from Ferguson Bryan.

Participants here at Ames Research Center are too numerous to mention everyone individually. However we need to commend Garth Hull, John Leveen, Meredith Moore, Jeanette Remington, and Sukie Stanley, for providing special assistance in the selection process of the 20 SHARP student trainees. These dedicated staff members made up the management team that provided helpful comments and suggestions, spent hours reviewing, evaluating, and criticizing SHARP, and serving as an advisory team throughout the entire program. We express gratitude to Clarice Lolich, who coordinated a very enriching Space Day experience for the "84" SHARP student trainees. We must thank Jean Barrick, Mike Donahoe, and Oliver Howell who were on call at a moment's notice.

It is impossible to reveal in words the loyal service and commitment given by so many people to SHARP "84." These student papers represent a labor of love from a host of very dedicated NASA Ames employees and students. So to each and every one who had any major or minor part in the SHARP "84" drama we say, "THANK YOU!"

JOB DESCRIPTION

James Aguilar

My name is James Aguilar and I work for the Telecommunications Branch under the supervision of Bob Gibson and Skip Gross. I would like to welcome you to the exciting and fascinating world of equipment verification. Yes, that's right, that great field is also known as counting telephones, which takes up the first part of my day. It's tough work but NASA seems to feel that it is a vital task that only a select group of SHARP students could handle. You never know, we may do your building someday. There isn't much to say about this tremendous task that we must conquer. I am quite honored to serve my country in such an honorable manner.

The second part of the day, I am involved in projects which aren't half as exciting as counting telephones. I work along with engineers communicating with various satellites around the universe. Many different electrical components need to be made in order to make the quality of the communication ideal. The senior engineer of our building gives us informative lectures on various topics dealing with electronics each day.

The highlight of my week is participating in activities on Fridays with Mrs. Powell. We have taken trips to Santa Clara University as well as the Stanford Medical Center. These trips have been extremely informative. Many other trips have been planned for the future that I am looking forward to. This summer has a great deal in store for me, even though counting telephones can be quite monotonous.

LACK OF COMMUNICATION

James Aguilar

Isolated, third-world nations, such as Madagascar and others in the Pacific, desperately needed contact with the rest of the world in 1964. In times of emergency, these people were forced to receive primitive forms of medical care, instead of the advanced forms of care available to the rest of the world. The inhabitants of these regions were definitely in the dark in regards to technology. The real problem was that they didn't have the money to become technologically enlightened.

In 1964, the International Satellite network, Intel Sat, recognized this problem. Intel Sat offered them the equipment necessary to transmit and receive broadcasts. This proposed system was infeasible to these people because of the exorbitant one-million-dollar price tag. Each nation would be forced to have its own channel, which made it quite expensive.

It appeared as if these troubled nations would remain in the dark for a while. NASA came to their rescue by launching the Application Technology Satellites system. There were six satellites in the ATS system. Each individual satellite had 12 transponders. Because of the designed polarization, there were two channels on each transponder for a total of 24 channels. Nations were able to afford this system by sharing a channel and thus sharing the price. Communications were set up with Minneapolis and Saint Paul, which were the medical headquarters for these people. Doctors were on call around the clock. In the event of an emergency, the doctor would advise the people near the patient on what to do. The people experienced many problems in using the system. When there were emergencies, sharing channels made it quite inconvenient. Priority was given to the most severe cases. These satellites were designed using state-of-the-art engineering. The quality in their design has enabled them to live a great deal longer than their proposed life expectancy of 2 to 3 years. Of the six satellites that were originally launched, two remain functional today. These two satellites are on their "last legs." The nations realized this problem and approached NASA.

NASA began extensive research on the issue of developing a feasible and practical system of communications tangible to these people. NASA came up with the idea of developing a Thin Route system of communications. This system would allow them to broadcast and receive, using a thin bandwidth. They would only use a small portion of a channel and thus many countries would be able to communicate problem-free.

NASA assigned the Ames Research Center to successfully develop a prototype system. NASA would like to make this system available to these nations for two hundred thousand dollars. If the prototype Thin Route system is successful, NASA will turn the project over to private industry for bidding. The lowest bidder will get the contract from NASA Ames and mass-produce the systems. The nations will benefit a great deal if Ames is successful in completing this project.

The Thin Route project's main skeleton consists of the ground station, the dishes, and the MATE van. The ground station is the transmitting and receiving headquarters. The ground station enables us to pick up signals from satellites as well as transmit signals. We are also able to analyze frequencies. The dishes receive radio waves that are being transmitted from various satellites throughout our galaxy. Sadie and I have worked on designing a winch that will facilitate the process involved in mounting the panels on the dishes. The panels extend the diameter of the dish which will increase the range of frequency that we can receive.

Some of the advanced equipment necessary in the Thin Route project are spectrum analyzers, audio spectrum analyzers, and echo cancellers. A spectrum analyzer takes in a frequency-modulated signal and displays it on a Cathode Ray Tube (CRT). A cathode ray tube is what one sees as a computer monitor. The spectrum analyzer has the ability to magnify or minimize different aspects of the frequency that is entered. It is used for interpreting radio signals that are used for telecommunication purposes. Sadie and I are currently assembling an audio spectrum analyzer which picks up an audio range of frequency and interprets it on a cathode ray tube. The audio spectrum analyzer can magnify and manipulate the frequencies that are entered in the device. Sadie and I have also assembled an echo canceller. Because of the thousands of miles which separate satellites and Earth, signals are not always clear. There is often an echo developed when communicating. An echo canceller does exactly what its name implies, cancel the echo.

Sadie, Greg and I are also working on establishing a main data network which will enable computers to communicate with one another freely. The demand for computers has increased and the availability of computer outlets is diminishing. So we are trying to tie in the data lines with the telephone lines. We do our work in this project by going to each building and room on the base in order to determine equipment verification. We determine the types of data jacks, phones, terminals, as well as their location in the various rooms. This is very tedious work, but in the long run it will benefit the telecommunications system at NASA Ames Research Center.

This information was obtained through lectures given by Brad Gibbs, Skip Gross, Mark Leon, and Mike Koop.

JOB DESCRIPTION

Julie Aochi

Working for Dr. Henry Leon in the Life Science Biological Experiments department has proved to be interesting. So far, I have been involved with the stowage and primate projects for SL-4 (Space Lab 4), which is to be launched in 2 years. I have also attended a Critical Design Review (CDR) for SL-4.

My involvement with the stowage on SL-4 basically is to identify the company and make of items which will be carried on the space lab. This involves consulting the SL-3 blueprints for the ID numbers for reflown equipment, asking the people responsible for SL-4's experiments to identify the equipment for their projects, and compiling a separate list with the numbers and equipment. To compile this list, Anne Kikoshima, who is also working on SL-4's stowage, has allowed my coworker, Louise Elsea, and me access to VAX, the computer system. So far, we have succeeded in identifying some of the equipment for the Primate and Hematology experiments and have begun compiling a list for the stowage items on the VAX.

Besides compiling a list of stowage items for SL-4, Louise and I, under the supervision of Lea Ibarra, Dr. Leon's student assistant, have been able to work over at the Animal Colony. The Animal Colony is where the squirrel monkeys and other research animals are kept. At the Animal Colony, I have been able to observe the squirrel monkeys having their catheters flushed, monkeys being tested in their flight restraint modes, and squirrel monkeys being trained to be accustomed to being hauled up and down. Also, I have helped in setting up the fans for the Research Animal Holding Facility (RAHF), and in preparing for the monkeys' catheter flushing. I have been able to help monitor the monkeys, and help in cleaning out a trailer for them.

I would like to add that I spent time at the beginning of my job attending a CDR for SL-4. I found it very interesting, for it enabled me to receive an overall picture of SL-4.

Overall, I enjoy my job very much, even though there are periods when I have nothing to do. I find the experiments going up on SL-4 fascinating. I enjoy working with Louise, Lea, Anne, and Dr. Leon.

PRECEDING PAGE BLANK NOT FILMED

PRIMATE EXPERIMENTS ON SLS-1

Julie Aochi

BACKGROUND

As a SHARP student for Dr. Henry Leon, I have been able to help prepare for Spacelab-4 (SL-4 or SLS-1), which is to be launched in 1986. Under the supervision of Dr. Leon and Lea Ibarra, his Student Assistant, I have participated in the preparation for the two primate experiments going up on the Shuttle. Even though my work on this project only involves jobs such as trying to train the monkeys to tap and cleaning out their cages, it is important to the overall success to the SL-4 primate project. This project has far-reaching applications to man in space.

INTRODUCTION

Since the first manned spaceflight, man has experienced various physiological changes (e.g., puffy faces) in a weightless environment. These changes, however, reverse themselves when man returns to Earth. Understanding how and why these changes take place is vital to man's mental and physical health in a zero gravity environment, and to man's expansion into space.

To study how the body system is affected in a space environment, NASA is sending up various experiments on the next shuttle flights. These experiments range from studying how frog eggs are affected in space to studying if plants can grow in a weightless environment. However, on SLS-1 there will be no experiments involving either frog eggs or plants, but only experiments involving humans, rats, and squirrel monkeys. The Life Science Flight Experiments Office here at Ames Research Center (ARC) is concerned only with the two primate experiments, the study of thermoregulation and the study of fluid and electrolyte homeostasis.

THERMOREGULATION IN THE PRIMATE

The purpose of the thermoregulation project is to learn and understand why the heat balance of homeothermic animals is disturbed in a weightless environment.

Homeothermic animals are animals which are able to maintain an almost constant body temperature through certain mechanisms which control heat loss and heat gain.¹ An example of a homeothermic animal is the squirrel monkey.

Contrary to belief, the body temperature of a homeothermic animal does not remain constant, but fluctuates. The temperature increases and decreases according

to circadian rhythms, 24-hr rhythms in mean temperature.² Various changes in light, noise, and activity can affect these rhythms, changing the animal's body temperature. The system which controls the circadian rhythms is composed of two pacemakers.³ One of these pacemakers controls the body's temperature rhythms, while the other controls the rhythms for the activity and eating levels. Most of the time, both of these rhythms function in synchrony.⁴ However, sometimes external factors cause them to lose their synchrony. One of these factors is believed to be weightlessness in space.

To explore this hypothesis, the thermoregulation experiment will study how the body's regulation of temperature, eating, drinking, and activity (heart rate) are affected in a zero gravity environment.

For the experiment, four young male Bolivian squirrel monkeys will be monitored continuously for their colonic temperature, ambient temperature, five skin temperatures, heart rate, and food and water intake.⁵ A blood pressure sensor will measure the heart rate, and monitoring temperature devices will measure the heat balance. Water and food pellets will be monitored by a sensing device in each Research Animal Holding Facility (RAHF). For 24 hr before the flight and the entire mission, the monkeys will be housed in separate RAHFs, each of which has its own life support system. Also in each RAHF, a 12-hr light and 12-hr dark cycle will provide the monkeys with a sense of night and day. After the flight, the squirrel monkeys will be placed in simulation cages for an additional 96 hr, so that scientists can examine the monkeys for any significant changes during the monkeys' readaption to Earth's gravity.

At the end of the experiment, all data will be collected and combined so that each monkey's body temperature and heat loss can be determined. This information is important in that it will help man to discover if a weightless environment disturbs the temperature regulation in a homeothermic animal. The data also will help in determining how the circadian rhythms affect the other body systems. In addition, man will be able to learn how circadian rhythms are affected during lift-off, reentry, and readaption.⁶

THE RENAL ENDOCRINE PHYSIOLOGY EXPERIMENT

During past spaceflights, it has been noted that astronauts have experienced changes in the fluid and electrolyte levels, which are believed to be caused by the zero gravity environment.⁷ These changes are only temporary and reverse upon the return to Earth's 1-g environment. Even though there is little information available, it is believed that a weightless environment causes body fluids to shift upward from the legs to the head and chest area.⁸ This, in turn, causes a decrease in the thigh area, puffiness around the eyes, a "full face," and chest congestion.⁹ Also, it is theorized that a zero gravity atmosphere causes an increase in venous blood pressure, diuresis (a loss in water volume due to an increase in urine volume), and natriuresis (urine sodium excretion).¹⁰ During this period, there

should be a decrease in the blood plasma concentration, which will cause changes in the electrocardiogram.¹¹

To examine this hypothesis, four squirrel monkeys will be flown on SLS-1 so that the mechanisms that control the homeostasis of electrolytes and body fluids can be studied. The astronauts aboard will examine and inspect the monkeys for major physiological changes occurring as the body fluid shifts headward.

In order to do this, the squirrel monkeys will be equipped with both arterial and venous catheters. From the arterial catheter, blood samples will be taken at regular intervals. These samples will be then centrifuged and frozen in order to preserve the hormones and electrolytes in the blood plasma. This will be examined later after the flight. Blood from the venous catheter will be mixed with a saline solution and reinfused into the catheter to keep the monkey's normal blood volume. Blood pressure will be measured from sensors on both the arterial and venous catheters.

As important as the blood samples are the intake of food and water, and the collection of waste materials. The food (banana pellets) and water intake will be monitored by sensing devices in the RAHFs. Urine samples will be collected at 24-hr intervals from the urine collection subsystem. These samples, like the blood samples, will be frozen to preserve the hormone and electrolyte levels. Waste matter from the waste trays will also be collected for further analysis.

Since the same four monkeys will be shared by both experiments, the same pre-flight and postflight procedures will be followed in both. This includes placing the monkeys in the RAHFs 24 hr before flight and housing them in simulation cages 96 hr postflight. During these periods, the monkeys will be studied for any significant physiological changes.

After the flight, the blood and urine samples will be analyzed for electrolyte and hormone concentrations. Urine samples will also be studied for their sodium and calcium content. These data will be compared with the heart rate, EKG, and arterial and venous blood pressures.¹²

The data collected from this study will aid man in understanding the mechanisms that control the fluid and electrolyte levels. Also, man will be able to learn if groundbased studies testing body fluid levels are valid in a zero gravity environment. This information will help future studies of fluid and electrolyte levels in humans during spaceflight.

CONCLUSION

The primate experiments on SLS-1 will provide invaluable information on how body systems are affected in space. The thermoregulation project will provide man with data on how body temperature and circadian rhythms are affected in a weightless environment. Also, this study will provide insight on how to control the circadian

rhythms and regulate body temperature. The study of homeostasis in fluids and electrolyte levels will help man in addressing the problems of a fluid shift in space, and in finding a solution to head and chest congestion that astronauts experience in a zero gravity atmosphere. This knowledge will be vital to man's expansion and exploration into space, for it will help him in determining the obstacles that he must encounter in space.

FOOTNOTES

¹⁻⁴NASA Ames Research Center, Ames Research Center Life Sciences Payload Familiarization Manual: Books I and II (Moffett Field, California: Management and Technical Services Company, 1984), p. 16.

^{5,6}Ibid., p. 17.

⁷⁻¹¹Ibid., p. 30.

¹²Ibid., p. 32.

BIBLIOGRAPHY

NASA Ames Research Center: Ames Research Center Life Sciences Payload Familiarization Manual. Moffett Field, California: Management and Technical Services Company, 1984.

NASA Ames Research Center: Critical Design Review Space Lab-4 ARC Project. Moffett Field, California: 1984. (Note: The figures presented in this paper were taken from this publication.)

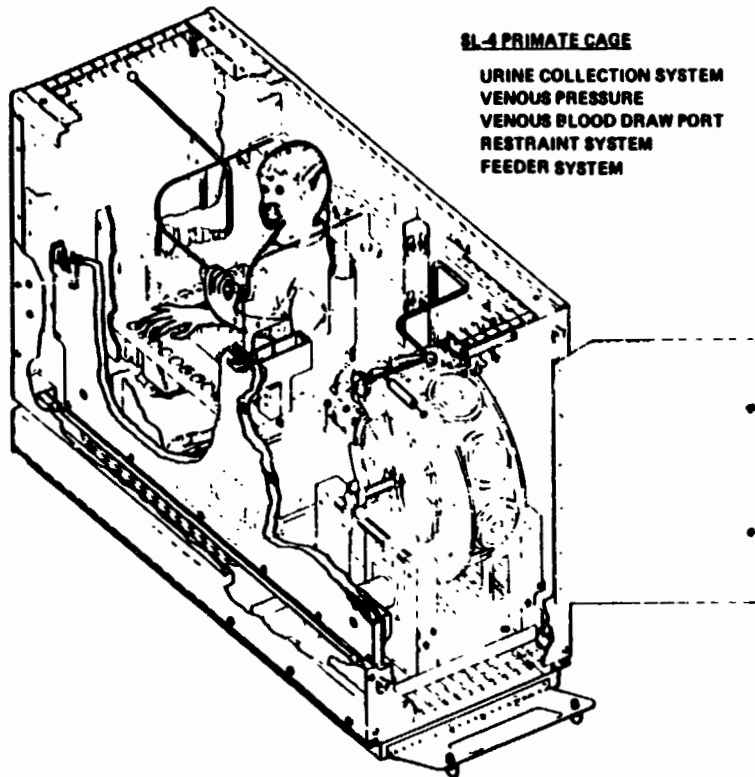
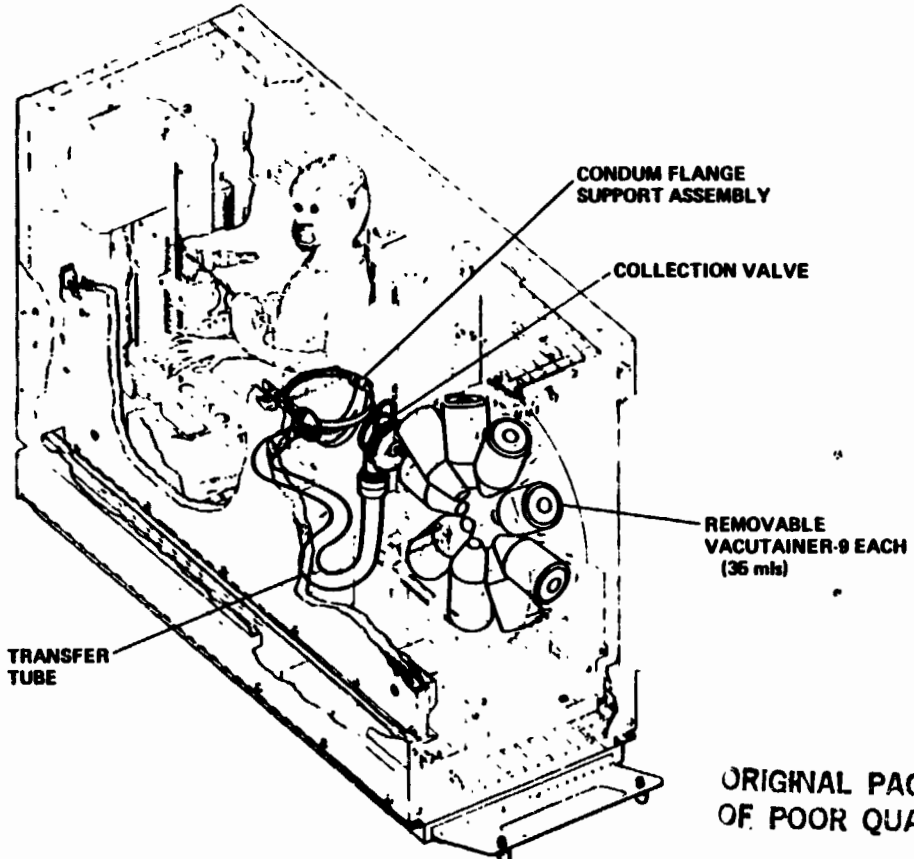

Figure 1.- SL-4 primate cage.



ORIGINAL PAGE IS
OF POOR QUALITY

Figure 2.- Urine collection system.

JOB DESCRIPTION

George Bakas

Without having seen every department at Ames, I feel safe in saying that the Space Science Division houses scientists working on some of the most exciting and profound questions and problems of our time. I came to this conclusion on my first day of work as a SHARP student, and employee/assistant to Dr. Kasting. Dr. Kasting is an atmospheric scientist and is currently working with a model that may help to explain the extinction of various species, including the dinosaurs 65 million years ago. So far I have learned a great deal about the atmosphere and ocean, which also involves the rock cycle; and quite a bit about computers. This is only the beginning, and by the time it's over, I will have learned much, much more.

It is impossible to begin without getting a little background, which is what I did the first few days. Dr. Hasting first explained the basics to me and then had me read a few good introductory and general books on the atmosphere that gave me a better understanding of what he was doing. Due to an extended computer breakdown, my reading period lasted longer than Dr. Kasting would have liked but there was nothing he could do about it. I learned a lot of things that were very interesting and even a few shockers. For example, I always thought that the carbon dioxide cycle is determined in part by the respiration of animals and plants. I was surprised to find out they don't even play a part in it and that it's basically determined by a state of equilibrium with the carbon in the ocean and land.

Dr. Kasting has introduced me to computer programming in a great way. He has given me some problems that require both calculus and programming in order to solve them. Presently I have finished over half of them and have learned some basic calculus and a lot of FORTRAN. I have also learned a great deal of word processing on the TERAK computer, that is, editing files and running and submitting programs to the main computer.

Working at Ames is great and will be a great experience. Dr. Kasting and some of the other scientists that I have met are a pleasure to work with. They are really down-to-earth people. I am quite sure that by the end of the summer, this experience will have proven to have been an invaluable one.

IS THERE MORE THAN ONE STEADY STATE FOR NOx?

George Bakas

Every year $50(\pm 25) \times 10^{12}$ g (ref. 1) of nitrogen oxide are deposited in the troposphere which makes up the first 10 km of the atmosphere. The manmade source of NOx (= NO + NO₂) exceeds natural sources by a factor of 3-13. Roughly 40% of it comes from the combustion of fossil fuels. Half are stationary sources, such as power plants and factories, and half are motor vehicles. Twenty-five percent of this originates from biomass burning, which is basically agricultural burning (the burning of land to create more space), the burning of the savannas, and wild forest fires. Other sources include lightning, oxidation of ammonia, and microbial process in soil. (Input from the stratosphere and volcanic activity make up a very small amount.)

Most NOx enters the troposphere as NO and readily reacts with O₃ (ozone) to produce NO₂ via



Nitrogen dioxide can be photolyzed (split by light)

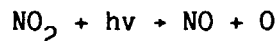

to recreate ozone

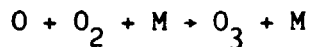

(where M is a third molecule of any type which is required to conserve momentum and energy). Nitric oxide is also converted to NO₂ by hydroperoxyl and organic peroxy radicals

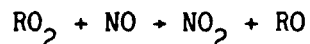

Depending on pressure and temperature, experiments show that NOx can stay in the atmosphere anywhere from 4 hr to 10 days. NOx is then removed either by converting to nitric acid



or by precipitating down as NO₂. Wet deposition (rainout) accounts for more than half of the removal of NOx and dry deposition (direct contact with the ground) for less than half, usually about one third. In polluted air masses, though, the dry deposition is more, 8-28 kg N ha⁻¹ yr⁻¹ compared with a wet deposition of 4-7 kg N ha⁻¹ yr⁻¹.

In February 1984, Warren H. White and David Dietz released a paper on the possibility of alternative steady states (an atmospheric state that does not change with time) for NOx. They state that at very high temperatures (like those produced in a nuclear exchange), a large amount of NOx would be created from the breakdown of N₂ and O₂ (ref. 2). The increased NOx in the atmosphere would cause it to become opaque to ultraviolet and blue light and O₃ would be greatly depleted. Thermochemical reactions would then dominate since the O₃ and OH that oxidize tropospheric NO to HNO₃ are photochemically produced (ref. 3). In an atmosphere with such a large amount of NO, the majority of it would be irreversibly converted to NO₂ by

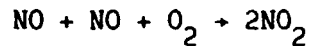

NO₂ could then combine with various species of NOx and water to form more NOx, including nitrous and nitric acids, in a variety of reversible and irreversible reactions. One would expect that eventually the NOx concentration would return to present-day levels after a period of time (say a few years), but according to White and Dietz there exist multiple steady states where the NOx does not return to normal (fig. 1). They show that the same NOx sources can sustain more than one NOx concentration in a steady state. Unfortunately White and Dietz can't give an explanation for the necessary increase in the NOx source.

Nothing in science is true or a fact until it can be successfully duplicated. I am making this statement as an assistant to Dr. James Kasting, an atmospheric scientist in the Theoretical Studies Branch of the Space Science Division. We are currently trying to duplicate the results of White and Dietz using a computer model of the atmosphere. Dr. Kasting's model is more complex (time-dependent one-dimensional photochemical model) than that of White and Dietz, which is a zero dimensional model. The main difference is that their model treats the atmosphere as a box while Dr. Kasting's is composed of layers, so that there is a difference between the troposphere and the stratosphere. His model is based on the following two differential equations:

Flux

$$\phi_i = -K_E n \frac{\partial f_i}{\partial z} \quad (1)$$

Continuity

$$\frac{\partial n_i}{\partial t} = p_i - \lambda n_i - \frac{\partial \phi_i}{\partial z} \quad (2)$$

where

ϕ_i flux of the i th species (pos. upwards) which is the velocity times the number density

n_i number density of i th species which is measured in molecules per cubic centimeter

- fi n_i = mixing ratio of ith species
- n total number density of atmosphere
- z altitude (cm)
- p_i chemical production rate ($\text{cm}^{-3} \text{s}^{-1}$) which is how much of a gas is entering the atmosphere
- li chemical loss frequency (s^{-1}) or how much is leaving
- K_E eddy diffusion coefficient ($\text{cm}^2 \text{s}^{-1}$) which changes as a function of height

We input the initial data on the atmosphere to the model and run it through the computer, which does all the various calculations for a certain period of time (say 1000 yr) or until the atmosphere reaches steady state. It will then print out roughly 20 different species of gases, with each gas having a printout of 30 rows corresponding to atmospheric layers or distances above the ground. For our current project we are using the present-day atmosphere and are increasing the NOx source by factors of up to 100. So far we've found that the atmosphere was oscillating back and forth between two NOx mixing ratios of about 3.7×10^8 and 3.1×10^{11} in a period of 30 yr. We are now changing tactics and changing the NOx concentration to calculate the source. Obviously there is something there, but right now we can only say that there are two quasi-steady states at those source strengths. Dr. Kasting doubts that we'll get the same results as White and Dietz since their box model was less realistic and they used a rainout period of 500 days (meaning it rained once every 500 days) which is much too low (see fig. 1). Most atmospheric scientists use 5 days. Whatever the results, I'm sure they will be worth the time.

REFERENCES

1. Logan, J. A.: Nitrogen oxides in the troposphere: Global and regional budgets. *J. Geophys. Res.*, vol. 88, 1983, pp. 10785-10807.
2. White, W. H.; and Dietz, D.: Does the photochemistry of the troposphere admit more than one steady state? Center for Air Pollution Impact and Trend Analysis, Washington University, St. Louis, Mo., 1983 (revised 1984).
3. Lewis, J. S.; Watkins, G. H.; Hartman, H.; and Prinn, R. G.: Chemical consequences of major impact events on Earth. In *Geological Implications of Impacts of Large Asteroids and Comets on the Earth*, L. T. Silver and P. H. Schultz, eds., Special Paper 190 published by the Geological Society of America, Boulder, Colo., 1982, pp. 215-221.

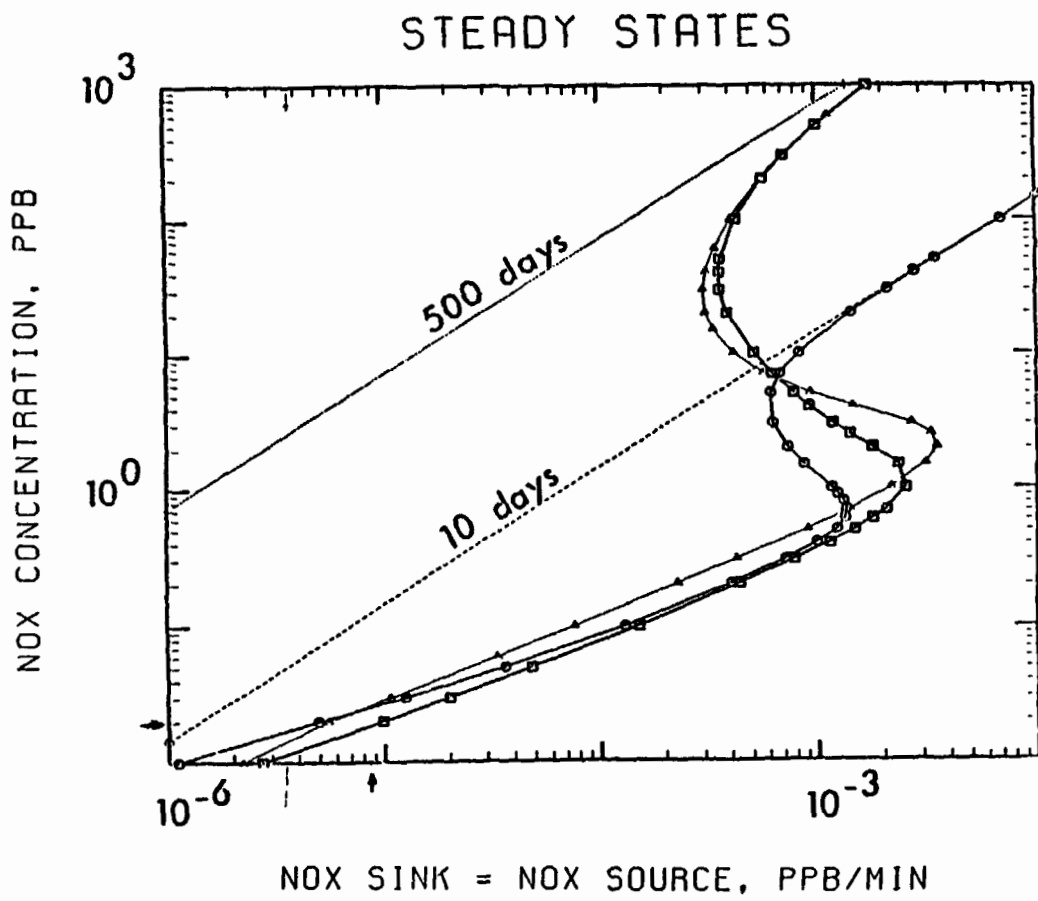

Figure 1.- Steady states. Graph taken from White and Dietz shows relationship between NOx concentration and source. The lines with geometric figures correspond to various physical sinks for NOx which are just the amount of NOx that can exit the atmosphere. The arrows show present day levels of NOx.

JOB DESCRIPTION

Derrick Brazill

Finding out that I was accepted into the SHARP program brought me many thoughts of what life would be like working for the government. Many of these thoughts were misconceptions. But before I can discuss my newfound knowledge I must describe what helped me gain this information--my job.

I work in material analysis. The group that I work with are working on graphite/epoxy formulas and compounds. These are polymers or plastics. I take measurements and record changes in volume and mass of these compounds under different conditions. This may sound unimportant and boring, which sometimes is the case, but since my mentor has explained to me that these compounds may be used to make airplanes, I have a greater understanding of my work. Of course I did have to do some background work. It helped me to comprehend, and peaked my interest in, the project. My job may seem monotonous at times, but it is actually an excellent learning experience. The reason it is a learning experience is that the misunderstandings I had about the job got cleared up.

Upon hearing my job description, I made up some ideas about what working for NASA would be like. My first thought was that people working for the government are uptight and are always rushing around. I was shocked to find out that the people in my lab room were friendly, helpful, and easy to get along with; the people here are just like any other "normal" people anywhere else.

Another misconception I had was about how interesting my job would be. When I read about occupations, I never read about the mundane aspects of the jobs. This job has shown me that side. Many of the tasks I perform are so boring and mindless I could do them in my sleep. It isn't all glamorous.

Getting a job with NASA has taught me a lot, from how to fight rush hour traffic to all the thinking that goes into the selection of a good (or should I say edible) cafeteria lunch. But most of all, it cleared up many of the wrong ideas I had about work. This is important because I feel that it is better to have a belief destroyed by a truth than to continue believing in a misconception.

PRECEDING PAGE BLANK NOT FILMED

THE PHYSICAL EFFECTS OF DIFFERENT STRESS SITUATIONS ON GRAPHITE/EPOXY COMPOUNDS

Derrick Brazill

INTRODUCTION

The work that I am doing with the T300/5209 and T300/934 compounds has been divided into three experiments and therefore has three purposes: (1) to observe the weight loss from thermal spikes, (2) to examine diffusion and swelling in a graphite/epoxy composite, and (3) to study the hygrothermal effects of a graphite/epoxy compound near the glass transition temperature (T_g).

"The glass transition temperature is described as the point or narrow region, on the temperature scale where the thermal expansion coefficient undergoes a discontinuity and below which configuration rearrangements of polymer chain backbones are very slow."¹ Within about 50° to 80° C of T_g , physical properties undergo radical change. These changes are related to free volume (V_f) effects and occur at temperatures experienced in real-life situations.²

The glass transition temperature has been studied prior to my experiments. Yet the purposes of earlier experiments were different. They were designed to estimate this temperature. This was done through the use of dry thermal expansion. The temperature was estimated to be approximately 94°C. Since the glass transition temperature has already been discovered, I will test compounds at and around it. This will help us understand how the compounds are affected. Overall, the work that I do will give more insight into the processes that are at work when graphite/epoxy compounds undergo change near the glass transition temperature.

EXPERIMENTAL

For Weight Loss during a Thermal Spike for T300/5209 Laminates

Thermal spikes, in this case, were used to examine desorption of the T300/5209 laminates. Up until now, there have been two theories for the process of desorption. One is that it is water vapor pressure phenomena, and the other is that it is a free volume phenomenon.³

Samples of T300/5209 laminate were saturated in a 40°C water bath for approximately a year. These samples were cut 4 in. long by 0.25 in. wide.

The samples were put in an oven at room temperature, 40°C, 60°C, 80°C, 100°C, 120°C, 140°C, 150°C, and 160°C. In between spikes the samples were allowed to reach equilibrium in the 40°C water bath. We believed that equilibrium was reached when the sample attained the weight it had before the thermal spike. This sometimes took hours at lower temperatures and days at higher temperatures. After the thermal

spikes and before the weighings, the samples were allowed to cool. This was done because sometimes the heat from the sample would heat the air around the scale and would make the samples appear lighter. Once the samples had cooled to room temperature, weighings were taken and recorded. Temperature was plotted against percent weight loss to see if a change of slope occurred that had occurred in another compound (AS/3501).

Note: Each temperature should have its own sample. I think this because at higher temperatures the samples undergo damage, since they don't go all of the way back to their temperature of 40°C weight. I used only two samples.

Diffusion and Swelling in T300/934 Graphite/Epoxy Composite

This study was done to inspect the solvent transport process in glassy polymers. It is believed that this process involves two smaller processes. These are diffusion, which is controlled by a concentration gradient, and volume relaxation, which is controlled by a time-dependent response to swelling stress.⁴ The relative contribution of the two processes to the kinetics of solvent uptake can vary with the environmental conditions, producing a variety of possible absorption curve shapes ranging from that of ideal Fickian diffusion to that of non-Fickian controlled absorption.⁵

The samples used were originally 2 in. long by 2 in. wide. They were annealed at 150°C to remove any surface moisture for 3 days in a vacuum oven. They were cooled gradually and then weighed and put in 74°C water bath.

Weight and length and width measurements were taken daily and then every other day. Length and width were measured in three different places (both ends and the middle) to be more accurate. Since swelling does not occur evenly, this must be done. These values were then averaged. To control error due to thermal expansion the measurements were taken within 15 sec of being removed from the water bath. After each measurement the samples were placed back into the water for the same reasons. After the samples were allowed to cool to room temperature, as not to upset the balance, they were weighed on a mettler scale, which has an accuracy of ± 0.00005 g. Graphs were plotted. The percent change in weight was plotted against the square root of time ($\sqrt{\text{time}}$) and $\log(\text{time})$ to see the dependence that solvent transport has on time. Change in length was also plotted against percent change in weight to see how the direction and rate of swelling is related to weight.

For the Hygrothermal Effects on Graphite/Epoxy Composite T300/5209 Near T_g

This experiment was conducted to study the reverse-thermal effect in the T_g region. The reverse-thermal effect is experienced when a polymer saturated near T_g is put into a lower temperature. Instead of losing weight as theorized, it gains weight.⁶

The samples used were originally 0.25 in. wide by 4.00 in. long. The samples were cut so that the fibers are oriented at a $\pm 45^\circ$ angle to the length of the samples. These particular samples had been soaking in a 74°C water bath for over a year to be sure of saturation.

Volume and weight measurements were taken daily and then every other day. Volume was determined by taking length, width, and depth measurements with a micrometer with an accuracy of 0.02% of an inch. Measurements for depth and width were taken in three separate places (both ends and the middle)--as per the request of Loan Nguyen, who had done work on this same composite last year--which were marked by lines. These values were then averaged. Measurements for length were taken at the two ends of the sample and then averaged. As stated before, swelling does not occur evenly and for better results measurements should be taken in separate places. After collecting and organizing the data, the percent weight gained was graphed against $\sqrt{\text{time}}$ to see the time dependence. Change in volume was also plotted against volume of water absorbed to see how they are related.

OBSERVATIONS AND DISCUSSIONS

Desorption

In samples of T300/5209, the samples that underwent the thermal spike, desorption occurred. It happened linearly up to about 114.6°C . After this point, the line increased its slope drastically. This is exactly what happened to the AS/3501-5 that experienced a thermal spike. The point at which the 3501 compound changed slope was T_g (177°C). This was further proved with the use of a differential thermal analyzer. Therefore it can be said that the T_g of T300/5209 is about 114.6°C .

One of the problems with the 3501-5 thermal spike was that its T_g was so high that it was unclear whether desorption was caused by water vapor pressure (hydrogen bonding) or free volume, because water vapor pressure change occurs around this T_g range. Since epoxy is similar to water in hydrogen bond makeup, this effect could be a possible occurrence. Since T_g for 5209 is much lower than that of 3501-5, water vapor pressure would not be a possible factor in desorption to the extent that it may have been in 3501-5. Since the thermal spikes for 5209 provided the same information that the ones for 3501-5 did, it can be safely assumed that the weight loss is a free volume effect and not a water vapor pressure (hydrogen bond) phenomenon. This is in keeping with the idea that free volume increases with temperature greatly above the glass transition temperature.

Diffusion

"As the temperature is increased, the molecules vibrate more energetically and have a tendency to relocate themselves in the amorphous molecular structure. As they move, they provide 'free space' and therefore allow moisture to be

absorbed."⁷ If absorption is caused purely by diffusion, then the graph of change in volume versus volume absorbed would be linear to a point and then would flatten out.



If swelling is involved, then it would look like this.



As of now, I lack data to make a usable graph.

Reverse-Thermal Effect

The four samples of T300/5209 that had been saturated at 74°C gained weight after they were placed in the room temperature water bath. Although this goes against expected behavior, it does coincide with the theory of reverse-thermal effect. One interesting thing did occur. Even though the weight increased, the volume remained the same and in some cases decreased. There is no known reason for this as of yet.

Change in Length and Width

In all four samples of T300/934 compound, length is the only direction that keeps increasing greatly with time. The range of percent increase in width is 0.13% to 0.19%. The length, however, had a much greater percent increase. It increased to 1.1% to 1.6%.

It is believed that the structure of the fibers is the cause of the one-way expansion. In this sample, the fibers run along the width. Graphite/epoxy is known to be anisotropic, that is, expansion varies with the orientation of the fibers. As a result of thermal agitation, spaces between the layers increase more in length than in width. It is because the bonds between layers are weaker than the one within layers. Since the layers here run parallel with width, width shouldn't change much; but length should, and does.

CONCLUSION

Since I have just begun this work, I will not have time to finish my experiments. Because of this, I have reached no conclusions of my own. Nevertheless, I have been able to prove or disprove some other theories. First of all, the idea that the orientation of the fibers has an important effect on the direction of

thermal expansion, believed by Loan Nguyen, has occurred in my experiments. The four T300/934 samples soaked in 74°C water swelled only in one direction. Secondly, the reverse-thermal effect has been experienced by the D and E series samples. Thirdly, the belief that the T_g of T300/5209 was $\pm 94^\circ\text{C}$ is incorrect. Using the thermal spike information, a better T_g would be $\pm 114.6^\circ\text{C}$, which is closer to the curing temperature.

My work is just a small sample of all of the experiments that have been done on graphite/epoxy compounds. Testing of this material has been done for the last 7 or 8 years. The overall goal of the work is to make aircraft and maybe spacecraft out of the composites. This would make the crafts much lighter than steel and much stronger. The only problem with this is that at T_g , the material fails to be glassy and becomes rubbery. The dangers of this are apparent. This is why my experiments, and others to come, are significant.

FOOTNOTES

¹Ferry, John: Viscoelastic Properties of Polymers, 1961, p. 218.

²Adamson, Michael, interviewed by Derrick Brazill, NASA Ames Research Center, June 22, 1984.

³Ibid.

⁴Judd, N. C.: Reinforced Plastics/Composites Institutes, 1980.

⁵Powell, J. H.: Rockwell International Corporation, Tulsa, Okla., 1976.

⁶Adamson, Michael: Thermal Expansion and Swelling of Cured Epoxy Resin Used in Graphite/Epoxy Composite Materials, 1980.

⁷Nguyen, Loan, 1983.

BIBLIOGRAPHY

Adamson, Michael: Thermal expansion of swelling of cured epoxy resin used in graphite/epoxy composite materials. Chapman and Hall Ltd., London, 1980, pp. 1736-1744.

Ferry, John: Viscoelastic Properties of Polymers. John Wiley and Sons, Inc., 1961, pp. 218-224.

Judd, N. C.: Proceedings of the 30th Anniversary Technical Conference, Reinforced Plastics/Composites Institutes, Section 18-A, 1980.

ORIGINAL PAGE IS
OF POOR QUALITY

% Weight loss of compound
T300/520g during Thermal
Spikes

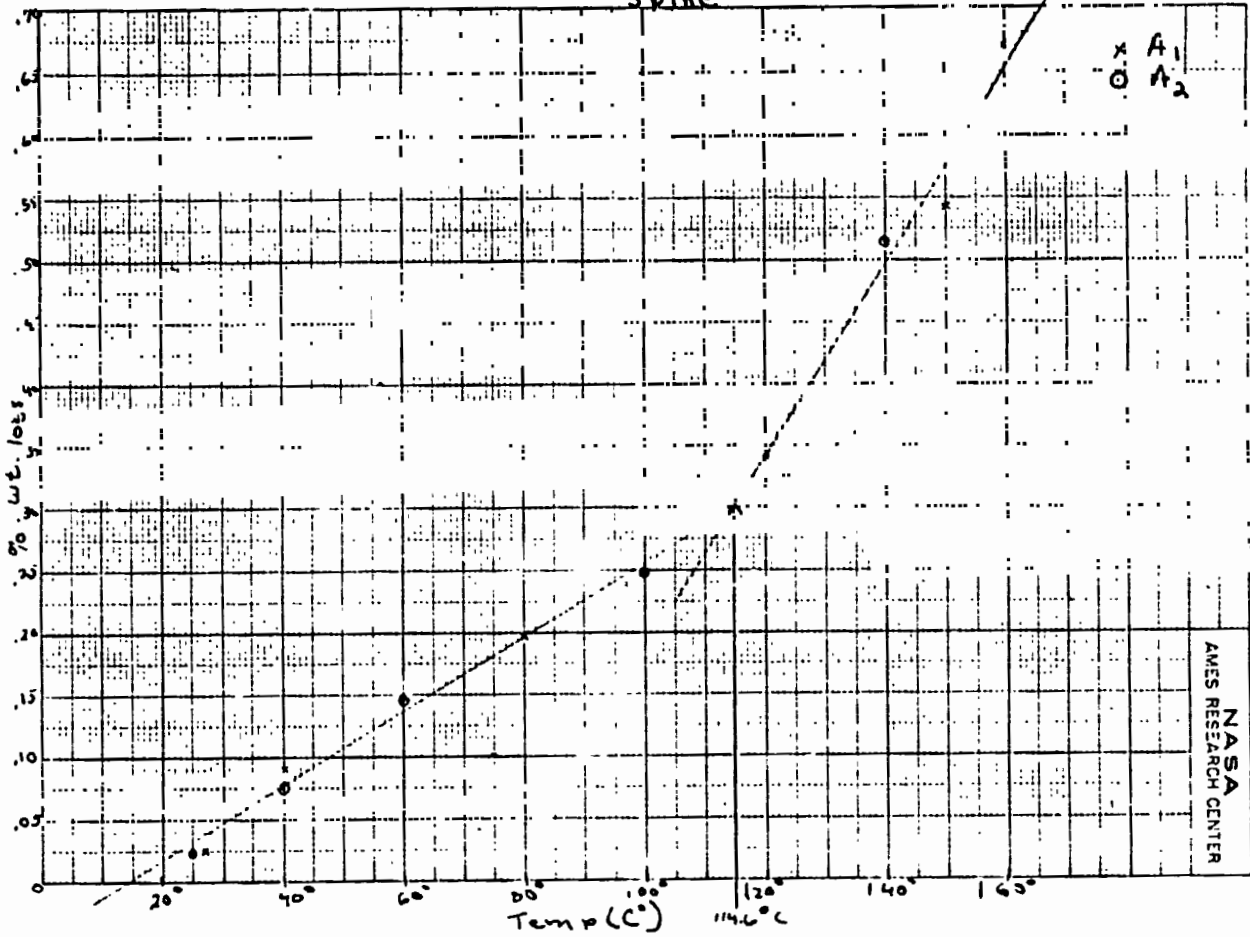

Figure 1.- Weight gained during thermal spikes.

ORIGINAL PAGE IS
OF POOR QUALITY

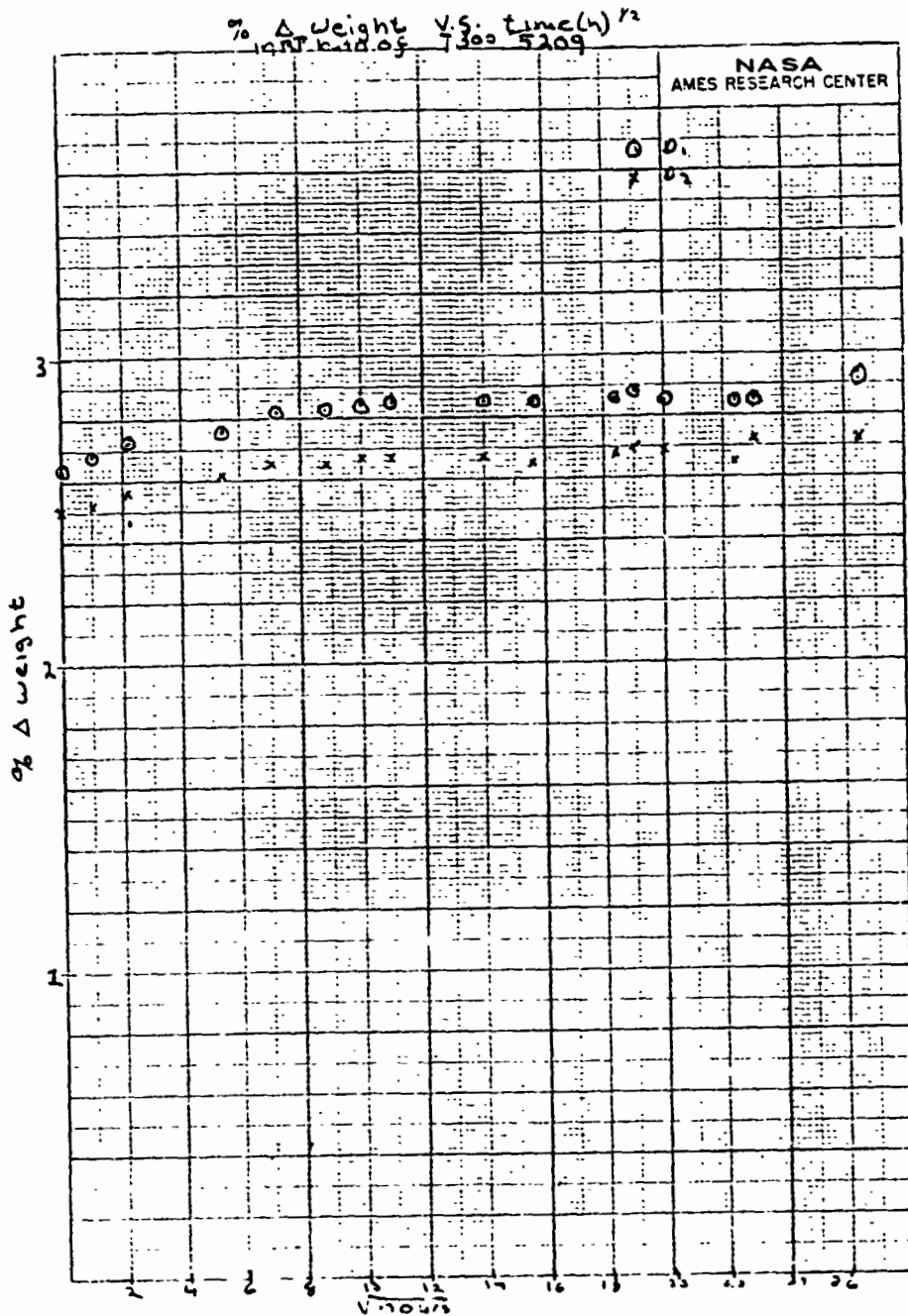

Figure 2.- Weight gained during reverse-thermal effect.

ORIGINAL PAGE IS
OF POOR QUALITY.

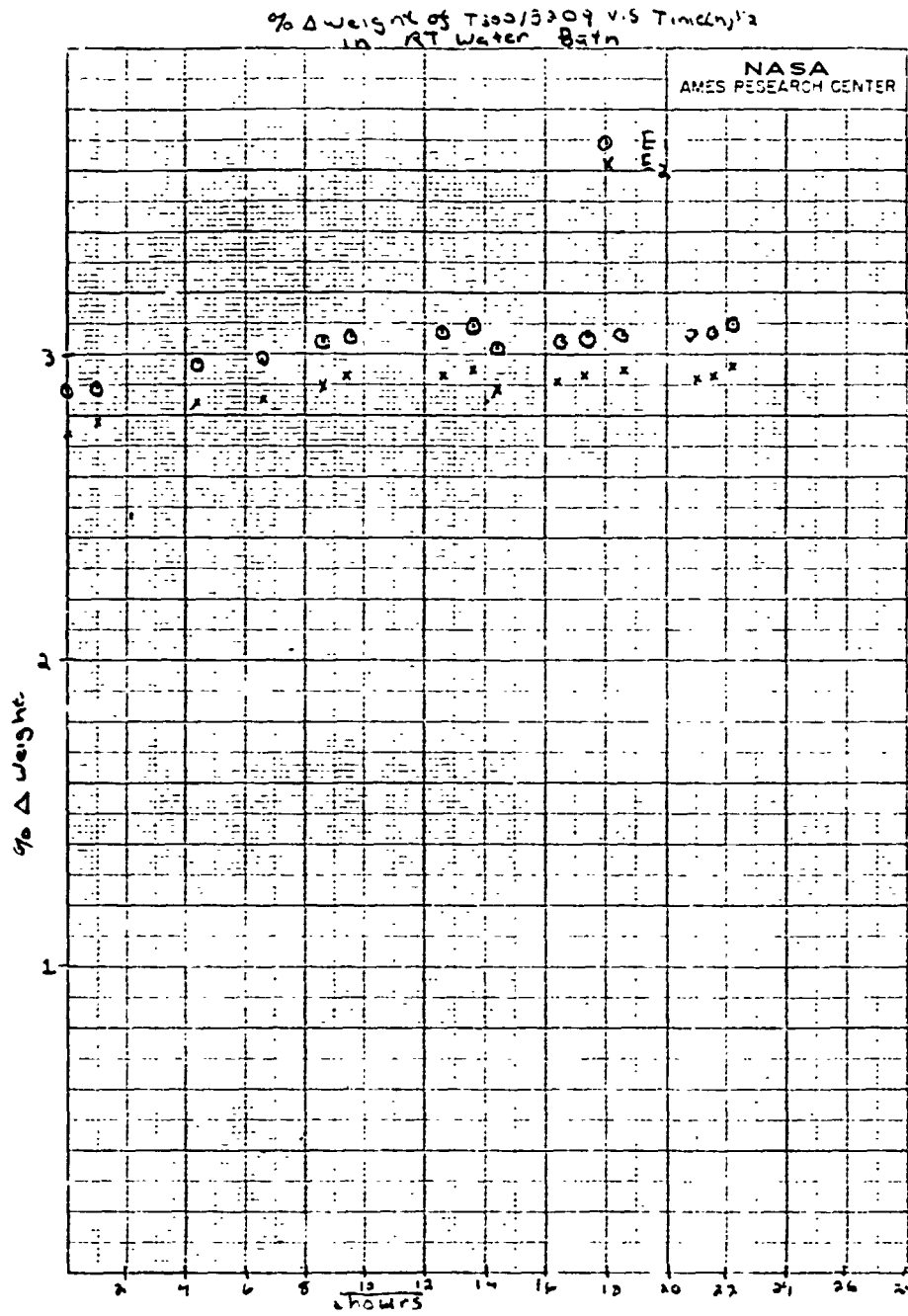

Figure 3.- Weight gained during reverse-thermal effect.

JOB DESCRIPTION

Sean Caffee

After working at Ames for 3 weeks, I have found my position of assistant in the engineering lab in Flight Simulations Branch to be both exciting and enlightening. I have learned many new electronic techniques regarding wire organization and placement. Also much of my time has been devoted to soldering various circuit boards and ribbon cable arrangements.

I spent the first week and a half of my job soldering. My responsibility was to solder various discrete components into a printed circuit board and to desolder little sockets from the same board. After situating all of the components on the board in the correct positions, I proceeded to install about 50 integrated circuit chips into the prepared circuit board. Throughout this process, I learned how to use a desoldering tool and an integrated circuit inserter.

I have also been fortunate enough to use the circuit designer that we have in our lab. Using it, I constructed (with much help) an operational amplifier circuit. I learned how to test the voltage outputs with an oscilloscope. An oscilloscope is a very useful instrument for observing and comparing waveforms.

For the last week and a half, I have been restoring an old computer kit left by a past engineer. I have mounted all the components on the chassis, rewired most of the connections, and installed a switch. The preliminary work is done, but I still have to troubleshoot the entire kit. I have received an abundance of help with this project by Ralph Decker, a technician who works in the lab with me.

So far, my experience working at Ames Research Center has been very rewarding and informative. I enjoy working in the engineering lab in the Flight Simulations Branch. Although I have learned a lot by working on projects, I have gained the most knowledge by talking to the engineers and technicians.

PRECEDING PAGE BLANK NOT FILMED

HARRIER

Sean Caffee

INTRODUCTION

Until recently the helicopter has been the only aircraft that has had the ability to take off vertically, but now there is a new type of airplane called the Vertical Take-Off and Landing aircraft. The Harriers are a new breed of airplanes. They have the ability to take off vertically and hover like a helicopter, and they also can fly at high speeds like a conventional jet. It is this feature that separates the Harrier into a new class of airplanes. In fact, this is the only characteristic of Harriers that makes them different from ordinary jet aircraft. There are two major characteristics of the hover ability. These are the actual hover ability and the reaction control system which enables the Harrier to maneuver while in the hover mode.

Physically, the Harrier is very different from a conventional jet aircraft. This difference lies in the fact that the Harrier has four jet nozzles. These four nozzles are distributed along the plane as two sets. The forward set, one on each side, are cool nozzles. Their thrust comes from high speed compressed air. This air is hot because it has been compressed, but it is relatively cool compared with the aft set of nozzles. The aft set of nozzles are fed with fuel, which in turn burns with the air rushing past, and sends streams of hot gas out the ends of the nozzles. All four of these nozzles have the ability to rotate from a starting position of straight down, to an ending position of straight back, a full 90°.

In a conventional aircraft, lift is provided by the wings when the aircraft attains a certain speed; therefore, a runway is used until the plane speeds up to the proper velocity. It is in this use of a runway that the Harrier differs from conventional aircraft. By using its four rotating nozzles to provide upward thrust instead of its wings, the Harrier can lift off from a standstill.

When the Harrier lifts off, there are two main forces involved: lift and weight. The lift of an aircraft directly opposes the weight of an aircraft. The Harrier weighs approximately 20,000 lb; therefore, the lift of all four nozzles must total 20,000 lb to initiate a hover maneuver. In the hover mode, the wings provide no lift whatsoever because there is no air rushing past them to produce an aerodynamic effect. When hovering at a constant height, the lift vector is straight up and unchanging, but if the aircraft is moving upward the lift vector will increase in magnitude. Once the Harrier is hovering above the ground, the next move is to shift from hover mode to flight mode. This shift is not made simply by pressing a button or flipping a switch; it is made by slowly rotating the nozzles toward the back of the plane.

As the nozzles rotate back toward the rear of the plane, the lift vector is no longer completely vertical. This means that now the vector can be resolved into

two vectors: one horizontal (thrust) and the other vertical (lift). In the midst of this process, the lift vector has shrunk; therefore, it no longer provides 20,000 lb of thrust and the aircraft will begin to fall toward the ground but at the same time will move slightly forward. To compensate for the decrease in altitude, the pilot must apply more thrust to the nozzles which will restore the lift vector to an appropriate level and increase the forward thrust vector. As the nozzles rotate more and more toward the rear of the aircraft, the lift vector shrinks more and more and the procedure repeats, more nozzle thrust, etc. However, between 40 and 50 knots, there is enough air rushing past the wings to evoke some aerodynamic lift. The closer the nozzles get to being straight backward, the larger the forward thrust vector will become, and the velocity of the aircraft will increase, thereby increasing the involvement of the wings in the lift. It has been found that at approximately 130 knots, the Harrier is completely wing-borne. When the aircraft is completely wing-borne, the wings provide all of the lift needed to support the plane in the air and the jet nozzles can be rotated straight back to contribute to the forward thrust only. The top speed of the Harrier, with the nozzles straight back, is eight-tenths the speed of sound, or 0.8 Mach.

I would like to thank Vic Ross for the time he spent helping me to understand the theory and the practicality of the Harrier aircraft, and also for reading over the first draft of this paper and pointing out some mistakes.

FLIGHT CONTROL

The flight controls on the Harrier are the same as the controls of a conventional jet airplane. Flight control is accomplished by the movement of control surfaces on the edges of the aircraft. These control surfaces may either move left and right or up and down off their resting position.

There are three different types of control surfaces for the purpose of movement which are the aileron, the elevator, and the rudder. Inside the cockpit the lateral stick controls the ailerons, which are located on the edges of the aft portion of both wings. They are able to move above or below the surface of the wing. The ailerons are used to control roll or the banking movement of the aircraft. The elevator is controlled from the cockpit by the fore/aft stick. The entire tail wing (horizontal portion) makes up the elevator. The elevator, as its name implies, is used to elevate or lower the nose of the aircraft; this movement is called pitch. It too is able to move above or below the surface of the tail wing. The rudder is controlled by pedals and is used to swing the aircraft's nose left or right; this movement is called yaw. The rudder is positioned on the aft portion of the vertical tail fin. It is different from the other two control surfaces in that it is the only control surface that is able to move to the left or to the right of the surface of the tail fin.

An example of a maneuver using these control surfaces is as follows: if the pilot wants to bank to the right, he applies lateral stick to the right. When the

stick is applied, it pulls a cable which actuates the ailerons. For a right turn, the right wing aileron would flip above the surface of the wing and the left wing aileron would flip below the surface of the wing. In these positions, air rushing past the top of the right wing will hit the aileron and force the right wing down; likewise, the air rushing past the bottom of the left wing will hit the aileron and force that whole wing up. This entire action will make the aircraft bank or roll to the right. The other control surfaces operate in a very similar manner.

REACTION CONTROL SYSTEM (RCS)

The reaction control system is the system which enables the Harrier to maneuver in the hover mode. In flight, the ailerons, the elevator, and the rudder control the movements of the aircraft, but while the Harrier is in the hover mode, these controls are ineffective. They are ineffective because for them to be effective, air must be rushing past the aircraft. The reaction control system only takes effect in the hover mode.

The RCS is made up of six little jets located on the nose, the wing tips, and the "stinger." These jets use the same hot air that powers the forward set of nozzles; it is routed through air ducts out to the various locations on the Harrier. The way these jets work is as follows: for example, if the pilot wants to pitch the nose up while in hover mode, the RCS jet in the nose would expel some hot air downward and at the same time the pitch control RCS jet in the "stinger" would expel some air upward. This action would cause the Harrier to pitch upward, but the entire aircraft would also move backward because the thrust vector has changed. It should be noted that while in the hover mode, the ailerons, the elevator, and the rudder will still be actuated, but they will not cause any change in the position of the plane.

CONCLUSION

After talking to one of the engineers in charge of the Harrier project and looking at the plane itself, I have concluded that the Harrier is definitely one plane that is here to stay. While it is getting harder and harder to find space for runways, the Harrier takes advantage of its ability to land in a 40 by 50-ft² area. This is a fantastic characteristic for landing upon crowded carriers at sea, shortened or damaged runways, and small confined areas. The Harrier has many great possibilities, and hopefully this NASA project will help explore all of them.

JOB DESCRIPTION

Mindy Dalrymple

My first day on the job at the Theoretical Studies branch of NASA Ames Research Center was slightly overwhelming. Thrown into a temporary task to fill the time until a permanent job could be assigned, I worked with two huge equations, calculating and graphing the relationship between the angle and the pressure of particles in space as they approach a star. I was very interested to learn, after completing the graph, that it supported a theory about the creation of the universe.

I was then assigned to help Dr. Robert C. Whitten with various tasks dealing with his IBM Personal Computer. I began laboriously reading the operating manual and was eventually given a very lengthy program, written in BASIC by Dr. Whitten, about the heating of the planet Venus. I typed in the program and worked with Dr. Whitten trying to debug it and many other programs in order to get them to run correctly. This helped me improve my typing skills, refamiliarize myself with the language of BASIC, and experiences using a text editor (i.e., moving around blocks of words, changing letters, deleting things, etc.).

There were many times, however, when Dr. Whitten was working on his programs and there was nothing for me to do. Because of this, I was also assigned to help Dr. Tom Ackerman. I began learning about the computer language FORTRAN and the Terak computer (the building's terminals that are locked into the building's main computer). Just today I wrote a program that will hopefully graph, for Dr. Ackerman, the absorption of sunlight by methane (an important compound of other planets' atmospheres) in terms of its frequency.

Sometimes it's hectic working for both Dr. Whitten and Dr. Ackerman, but more often it is interesting and educational. Besides, I am always surrounded by fantastic people who are often willing to interrupt their own work in order to help me.

VOYAGE TO URANUS

Mindy Dalrymple

The biggest problem with exploring the outer planets is time. As analyst Gary Flandro wrestled with this problem he became interested in some calculations, made by analyst Michael Minovich, which suggested that Jupiter's gravity could be used to alter the velocity and direction of a spacecraft, since it changed that of comets. Flandro calculated that a rare alignment of the outer planets would allow the craft to use Jupiter to reach Saturn, then Uranus, and finally Neptune. The result: all four planets could be reached in only 12 years, whereas otherwise it could take more than twice as long. The latest chance for this "Grand Tour" of the planets came when Thomas Jefferson was president. The next would be in 1977. Today, Voyager 2 follows Flandro's path with surprising accuracy despite budget cuts, equipment failures, aging parts, and limited propellant reserves (fig. 1). Jupiter and Saturn are past; Uranus and Neptune are still to come.

The Grand Tour was a long shot even after the launch of the Voyager, but its chances of success are continually increasing. On January 24, 1986, the Voyager 2 spacecraft should reach Uranus and supply scientists with information they've been hungering for (fig. 2).

I am just one of the many people involved with preparing for the Voyager 2's encounter with our seventh planet, Uranus. I have been using data involved with the methane in Uranus' atmosphere and its absorption of photons of sunlight. I have been writing programs which graph the relationship between the frequency and absorption of the photons, the frequency and the pressure of photons in different places of the atmosphere, and lastly between the frequency and the transmission of photons (which is calculated using the values of the pressure and absorption coefficients at the specific frequencies).

These graphs will help a group of scientists to make a model of Uranus' atmosphere by contributing the amount of methane in certain places of the atmosphere, and the amount of absorption of photons of sunlight that takes place there. The resulting data, in turn, will help teach us of the heating of Uranus' surface which tells us of the turbulence around the planet.

It is important for scientists to know the variations of direction and intensity of the turbulence before the Voyager reaches Uranus in 1986 so that they will know what to expect and how to deal with it.

Although my contribution to this study is a small one, it is also a necessary one. It will be satisfying to know that I aided the Voyager 2's flight to Uranus and hopefully its continuation on to Neptune.

BIBLIOGRAPHY

- Kane, Van R.; and Kohlhase, Charles : Voyager to Uranus and Neptune. Astronomy Magazine, AstroMedia Corp., W. A. Krueger Co., April 1, 1983.
- Morrison, David; and Samz, Jane: Voyage to Jupiter. NASA SP-439, U.S. Government Printing Office, Washington, D.C., 1980.
- Morrison, David: Voyages to Saturn. NASA SP-451, U.S. Government Printing Office, Washington, D.C., 1982.

ORIGINAL PAGE IS
OF POOR QUALITY

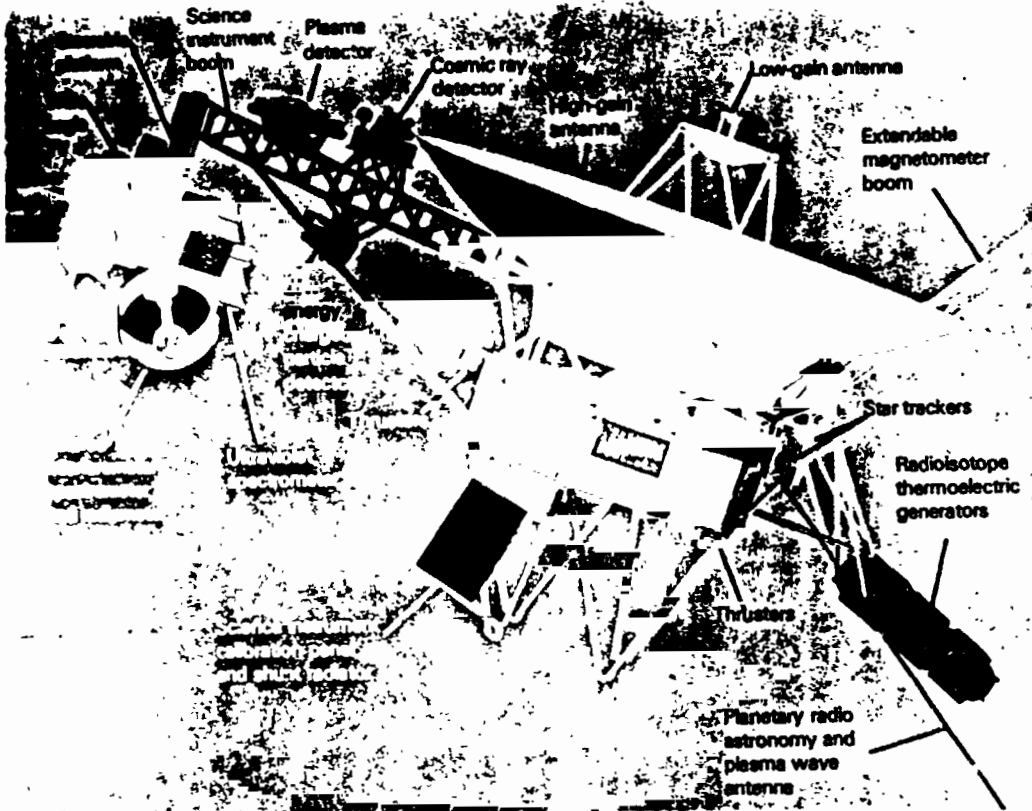

Figure 1.- A drawing of the Voyager 2 spacecraft.

ORIGINAL PAGE IS
OF POOR QUALITY

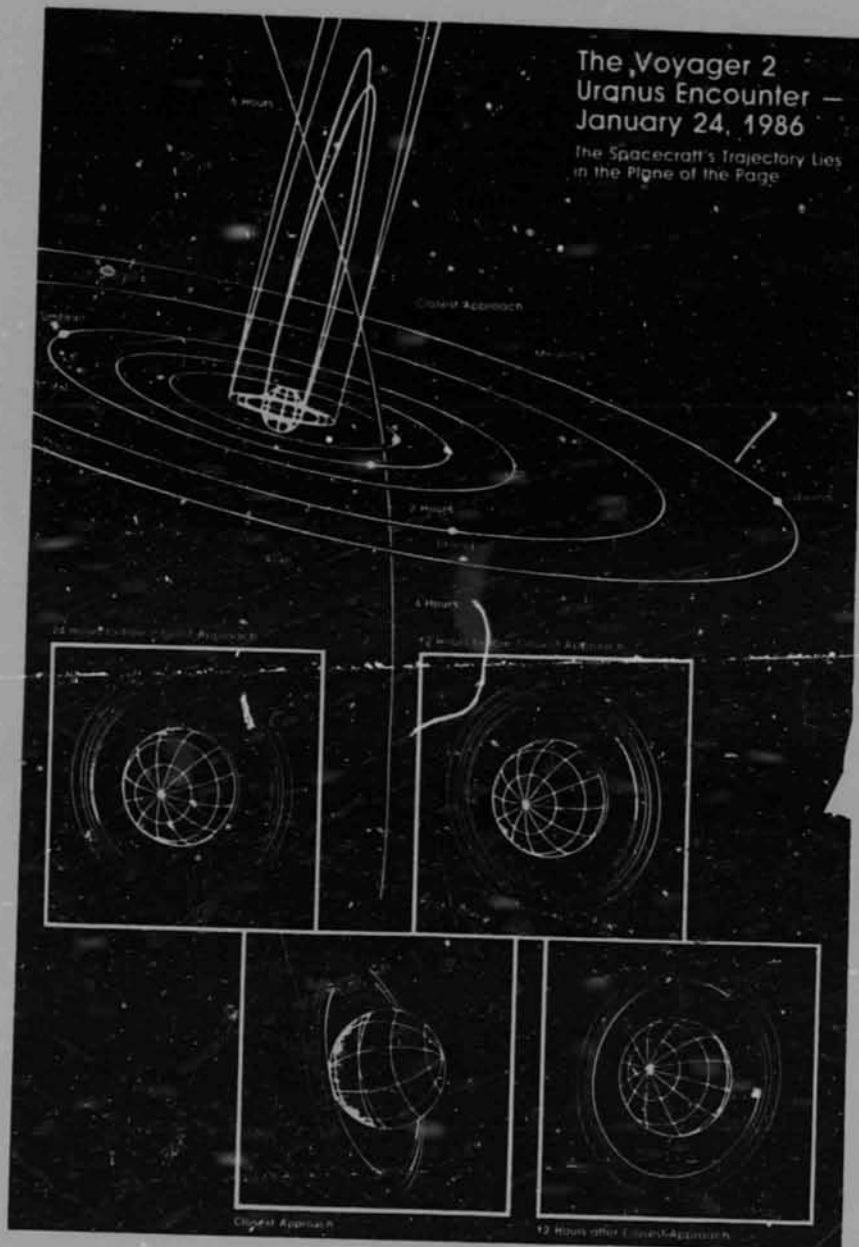

Figure 2.- The Voyager 2 Uranus encounter--January 24, 1986.

JOB DESCRIPTION

Louise Elsea

This summer Julie Aochi and I are working for Dr. Henry Leon, who is working on the primate experiments that will go on Space Lab 4. In the beginning, Julie and I went to a Critical Design Review of the animal experiments to go on Space Lab 4. This was an all-day affair, intended to review and clarify the progress made on the preparations for the experiments. The most interesting parts were when the scientists got into discussions. Two incredibly intelligent people, working on the same experiment, would have completely contradictory information on the same topic.

In the past few weeks following the CDR, we have done a lot of inventory on which items will be reflown from SL-3 and which items need to be reordered. This is usually frustrating, because items have as many names as the number of scientists using them, each inventory number for a list requires at least three sources, and the amounts must be deciphered and compiled from several contributing lists. We fed the numbers into the VAX computer to have a list of requirements for training the SL-4 crew.

We have also spent time over at the animal colony, where several types of animals are kept. We work with the squirrel monkeys that will ride in SL-4. Before we could go over there, we needed to get physicals so those in charge knew that we were healthy and could determine whether any illness we might contract had been caused by the monkeys.

Over at the animal colony, we prepared cages for monkeys, setting up food and water, and changing waste trays. We also helped condition the monkeys to their future treatment in the Space Shuttle. They will be driven to the Shuttle, so we drove them around, and they will be hoisted up and down for positioning, so we hoisted them up and down in their cages on a pulley. We learned how to fill syringes, and observed the flushing of catheters implanted in the monkeys to facilitate injections to be given in space.

Throughout my time, my relatives have jokingly inquired if I was going up with the Shuttle. I always give them a relieved "no," for I am personally frightened of such a prospect. I am grateful that I have the opportunity to work here, because this job will provide experience, contacts, and open doors that might otherwise remain shut.

PRECEDING PAGE BLANK NOT FILMED

A BRIEF DESCRIPTION OF THE TWO PRIMATE EXPERIMENTS TO BE CARRIED OUT ON SL-4

Louise Elsea

Recently, the Reagan Administration announced that plans for a permanent Space Station, which had been postponed for many years, would be resumed. Accomplishment of this goal would mean that humans would be spending extended periods of time in space. Previous space experiments have shown, however, that the zero-gravity environment causes physiological changes in both animals and humans, some obviously harmful. It is to explore these physiological changes, and to remove the dangers of hypogravity, that biological experiments are performed in space. Particularly relevant to human problems are those experiments carried out on primates.

On Spacelab 4 data for two primate experiments will be collected. One of these investigates thermoregulation of primates during altered gravity. In previous ground-based tests, primate heat distribution was shown to change during centrifugation (a way of subjecting subjects to higher-than-Earth gravity), the inner body cooling off and the skin temperature rising. In conducting the SL-4 study, the principal investigator, Dr. Charles Fuller, wishes to understand "the adaptive and homeostatic mechanisms triggered by spaceflight and to identify ways in which to correct any undesirable shifts in the homeostatic capabilities of the thermoregulatory control system."

The other experiment involving primates addresses the changes in fluid distribution and electrolyte content of blood that occur in spaceflight. During previous space missions, fluid shifts from the legs to the chest and head have been noted. Ground-based studies have shown decreases in blood potassium levels and increases in potassium excretion. Dr. Moore-Ede, the principal investigator of this experiment, wants to provide a basis for future study of these effects, and to determine the similarity of primate responses to human responses. Both primate experiments are intended to benefit humans by identifying dangerous physiological reactions to zero gravity and by suggesting possible solutions.

PROCEDURES

The same four squirrel monkeys will be used for both experiments. They will not be subjected to any unusual conditions save changes in gravity experienced during launch, inflight, and reentry. Specific physiological changes under these conditions, and readaption to Earth gravity postflight will be measured and analyzed.

Preflight

Twelve male squirrel monkeys will undergo conditioning in order to become accustomed to the inflight conditions. They will wear restraining jackets and be confined to small cages. The monkeys will be subjected to the same light/dark cycle they will experience in space: 12 hr light, 12 hr dark. They will learn to drink from a lixit, and to press a tap switch to obtain food. One food pellet is dispensed after a preset, adjustable number of taps, this number varying from monkey to monkey. Both urine samples and the contents of waste trays will be taken and analyzed. An arterial and a venous catheter, each containing a blood pressure sensor, will be implanted in the lower leg vessels of each monkey. Through them, blood samples will be taken. In addition, a probe will be implanted to determine deep body temperature, and external temperature will be measured at five sites: both arms, both legs, and tail. Preflight control data will be taken from all these sources, to be compared with that data obtained inflight.

Inflight

The same data sources will be monitored, by both computers and humans. The computers will actuate the urine carousel collection system every 4 hr. The astronauts will replace the urine carousel each 24 hr, although with nine storage tubes the carousel could last 36 hr if necessary. They will also change the waste trays twice during the mission. They will replace the primate feeder cartridges two or three times during the mission. When the astronauts remove a blood sample, they will do it at the same time each day. This is crucial, because the blood components being measured vary in amount over the course of 24 hr. Once the blood is removed from the animal, the red blood cells will be mixed with saline solution and returned to the monkey to maintain blood volume. The plasma will be frozen for postflight analysis. The monkeys will be visually checked by the astronauts during urine carousel changes, when the monkeys will be most visible. Each one's behavior and specific features of appearance will be recorded: breathing, eyes, coat.

Postflight

To complete the experiment in thermoregulation, the inflight temperatures and heart rates will be used to determine "body temperature and a heat loss profile for the animal." This will be compared with the control data to detect any abnormalities, signs of a possible problem with some other physiological process. The monkeys will be monitored for 96 hr after landing, and will be checked 1 mo later, to determine the rate of recovery from the effects of zero gravity.

The experiment in fluid and electrolyte displacement will be completed by subjecting the monkeys postflight to similar light/dark cycles and temperature conditions as experienced while aboard SpaceLab. Fluid samples collected inflight will be analyzed for electrolyte and hormone concentrations. Each type of sample will be measured for amounts of specific electrolytes. The data from preflight, inflight, and postflight will be compared for differences and possible causes.

CONCLUSION

The information obtained from these experiments will probably not be directly beneficial to those living on Earth. It might possibly lend insight to human disorders, but it will more likely help to solve problems obstructing the long-term colonization of space. The extra living space thus obtained would help to relieve the burden of a quickly growing population, and in this way the shuttle experiments will benefit mankind.

BIBLIOGRAPHY

Ames Research Center Life Sciences Payload Familiarization Manual: Books I and II. Ames Research Center, Moffett Field, Calif., Jan. 1984.

Press Kit Introduction (to Spacelab-4 Mission). Ames Research Center, Moffett Field, Calif., June 1983.

Spacelab Mission 4: Ames Research Center Primate Experiment Workbook. Ames Research Center, Moffett Field, Calif., June 1984.

ORIGINAL PAGE IS
OF POOR QUALITY

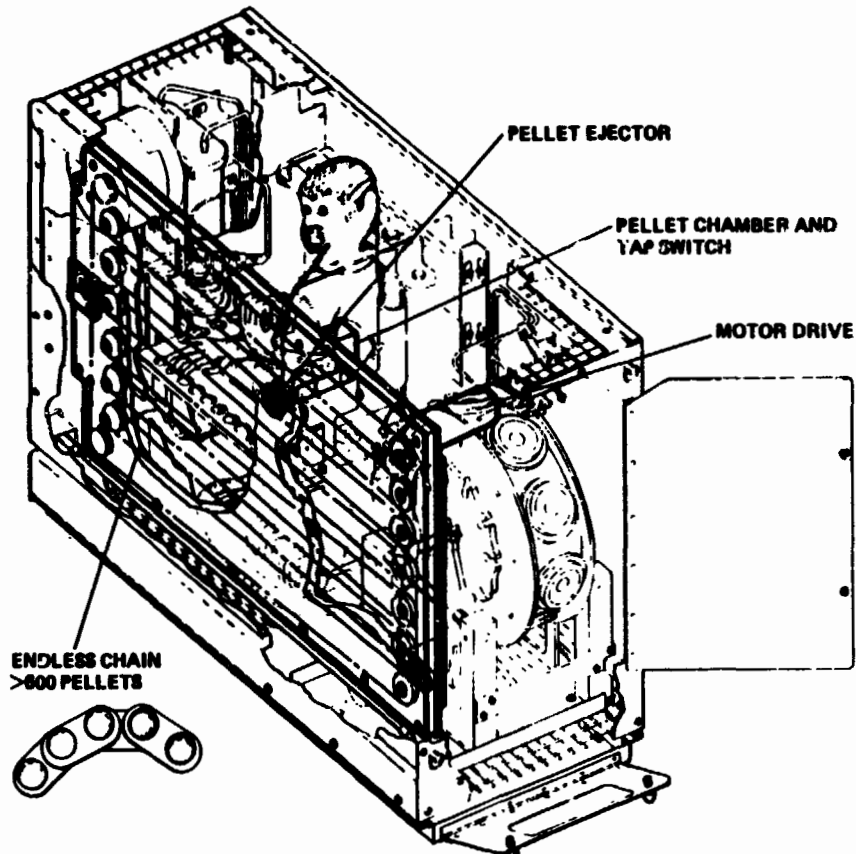

Figure 1.- Feeder.

JOB DESCRIPTION

S. Gregory Felix

ODE TO A TELEPHONE COUNTER

This is the story of Seth Gregory Felix, a young man who chose to work at NASA for the summer. Greg's workday is divided into 4-hour segments. The first part of his day is spent surveying and taking an inventory of all terminals and telecommunication devices in a given building. In other words, counting telephones. At first glance, this would probably appear to be a boring, meaningless type of busywork. But in actuality, this is simply the base of what is a very important project. Greg is finding out exactly what is on base and where everything is; "everything" being the phones, phone jacks, data terminals, and data jacks. Once this information is gathered, Telecommunications plans to install a vast communications web that will, in ten words or less, vastly improve communication between everyone on base.

The second part of Greg's day is spent under the direction of Skip Gross, Chief Engineer of the Thin Route Project. Eventually, this project will provide the technology for low-cost communication between the United States and the South Pacific. Recently, this project has focused on the development of dishes that will receive and amplify signals from different satellites.

To this reporter, it sounds like Greg has been exposed to a good learning situation that he couldn't get anywhere else, although he could probably be making more money. Tune in next week when I interview a girl who describes her new job at McDonald's as, "The like totally most killer thing that ever happened to me, ya know?"

PRECEDING PAGE BLANK NOT FILMED

THIN ROUTE PROJECT

S. Gregory Felix

TELECOMMUNICATIONS OFFICE

Six months ago, the Telecommunications Office was set up to regulate all telecommunication activities and to provide a total data service here at Ames Research Center. This new office is responsible for such things as providing computer data service and maintaining the phone system. Previously, these and other responsibilities were delegated to other offices. For example, the Computer Operations Branch, a branch of the office of the Director of Administration, maintained telephone repair service and all related telephone activities. This consolidation would still probably be in the planning stages if it weren't for a few events that pushed for the establishment of a single office. These were the breakup of AT&T and the "explosion of terminals being brought into people's offices."¹

AT&T had kept very good records of the phone numbers and locations at Ames. When AT&T broke up, the records system became less efficient. Thus, one of the goals of Branch Chief Brad Gibbs (now retired) was to validate and update the telephone records. This survey would include finding out not only where all the phones are and what their numbers are, but also the location of any extra phone jacks not being used.

At Ames, however, another survey also needed to be taken of the number of computers, their locations, and any extra jacks. Because of the constantly changing technology, it has become all but necessary to own a computer. Thus, many people have brought computers into their offices, and they require data service to make the computers function. This service includes obtaining and installing wires that would connect with the computers. Unfortunately, these things cost money. If the Office can find out how much data is available, and how much is wanted, then they can find out how much data service is needed and how much it will cost.

One solution that the Telecommunications Office is considering to solve the need for data lines is to run data service into rooms through extra telephone outlets. Cross-connecting electrical closets would make this possible where data wires and phone wires would interconnect.

I have been given the task of verifying equipment and taking inventory of available data service. At first, I considered it simply "counting phones." But after reading the following material, I hope you will realize as I did that I am doing the groundwork for a very important job. The Telecommunications Office will use my information to "meet the data needed, to improve network, and to provide service for it."²

THIN ROUTE PROJECT

Throughout history, Alaska, many Pacific islands, and parts of Africa had had very little communication with the outside world, due to their virtual isolation. Some islands would be lucky to see a ship or plane more than twice a year. This isolation led to several problems. While the world moved forward, progressing in every phase of society possible, these isolated areas remained in a somewhat primitive state. Medical assistance was impossible to obtain, and with nothing but their natural immunities to protect them, many people died of diseases such as the flu and the mumps. Nothing was done until the Department of Health, Education and Welfare decided it was time to help these people, and they asked Intelsat (the only agency with an installed communication system) to set up some type of communication system for them. Intelsat agreed.

In 1964, Intelsat presented an idea for Alaska, some Pacific islands, and parts of Africa to think about. Intelsat would send up a number of satellites, each having 12 transponders (with each transponder having the ability to go odd and even, thus having 24 channels). Each island would get a channel for itself (with Alaska and parts of Africa getting them too) and would then be able to communicate with the outside world. The only problem was that the islands couldn't afford the one million dollars that each channel would cost. As an alternative, Intelsat placed six applications, Technology Satellite, satellites in geo-synchronous orbit and all of the places shared them. If all of the places transmitted at the same time, then it was difficult to receive any signal; but generally, this system works. The islands were able to get medical assistance, and the outside world was able to warn them of an oncoming hurricane that might ravage an island. In spite of predictions that the satellites would last only a year, they have survived over 20 years. But they are getting old, and will very soon be unusable.

NASA has been asked to develop the technology for a new series of satellites and for portable stations that would be placed on each of the islands, and could both receive and transmit signals. The work NASA is doing for them has been called the Thin Route Project.

The idea NASA engineers are working on now is to squeeze the bandwidth of each signal, enabling each channel to contain up to 30 signals at a time. A problem is that as the signals get thinner, they become harder to understand. So, the object is to squeeze as many signals as possible on a band, make the signals intelligible, and also produce them at a low cost. The two main parts of this project are the dish that receives the waves, and the ground station, where equipment to interpret the signals are stored.

The dish is made up of three parts: the reflector, the subreflector, and the antenna. The signals come from the satellite, hit the fiberglass reflector (the big dish), and are bounced into the subreflector (the dish is curved in such a way that no matter where the signal hits it, it will be bounced at the subreflector). The signal is then bounced into the antenna, where it is taken into the ground station.

The ground station now has the job of interpreting the signals. There are many pieces of equipment, but the most important is the spectrum analyzer. "The spectrum analyzer takes in a frequency modulated signal and displays it on a Cathode Ray Tube. It has the ability to maximize or minimize different aspects of the frequency. It is also used for interpreting radio signals used for telecommunications purposes."³ It is through this device that we are able to aim the satellite at the small window where a certain satellite is transmitting from.

My work on this project takes place out with the dish, for the most part. Under the direction of Skip Gross and Mark Leon, I helped to assemble the dish and install the quadripod where the subreflector is located. I have helped Mark pinpoint some of the different satellites shown in figure 5, and have adjusted the dish for the best possible reception. My limited work in the ground station was spent learning such skills as soldering and wirewrapping. I have also learned a great deal from periodic lectures given by Mark Leon and Skip Gross on topics varying from diodes and car motors to radiation.

ACKNOWLEDGMENTS

I would like to thank Brad Gibbs and Roger Bjorkstrand for their assistance and perserverance in my endeavors in "equipment verification."

I would also like to thank Skip Gross and Mike Cooper for helping me to learn about electronics and satellites.

I would especially like to thank Mark Leon for taking so much time to help me learn about things and for being a good friend, Bob Gibson for requesting the students and thus giving me an opportunity to work here, as well as trying and succeeding in making me feel very comfortable, and Patricia Powell for spending her time with the SHARP program and giving me a chance to do more than "cook food" all summer. Please continue the program. It is an exciting and worthwhile experience I wish every youngster could enjoy.

FOOTNOTES

¹Brad Gibbs, interviewed by Greg Felix, July 24, 1984.

²Ibid.

³Mark Leon, interviewed by Greg Felix, Sadie Hathorn, and James Aguilar, July 23, 1984.

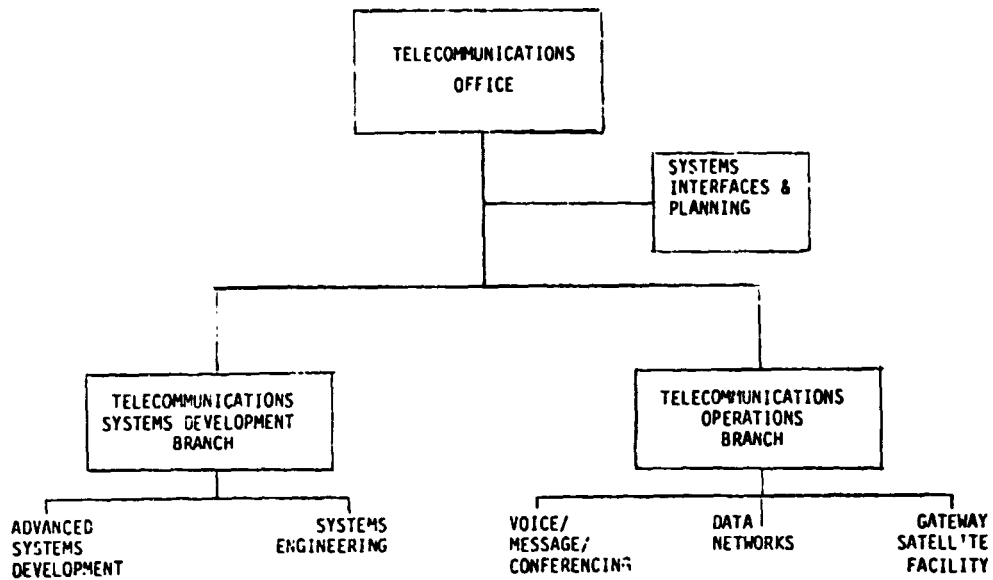

Figure 1.- Organization chart.

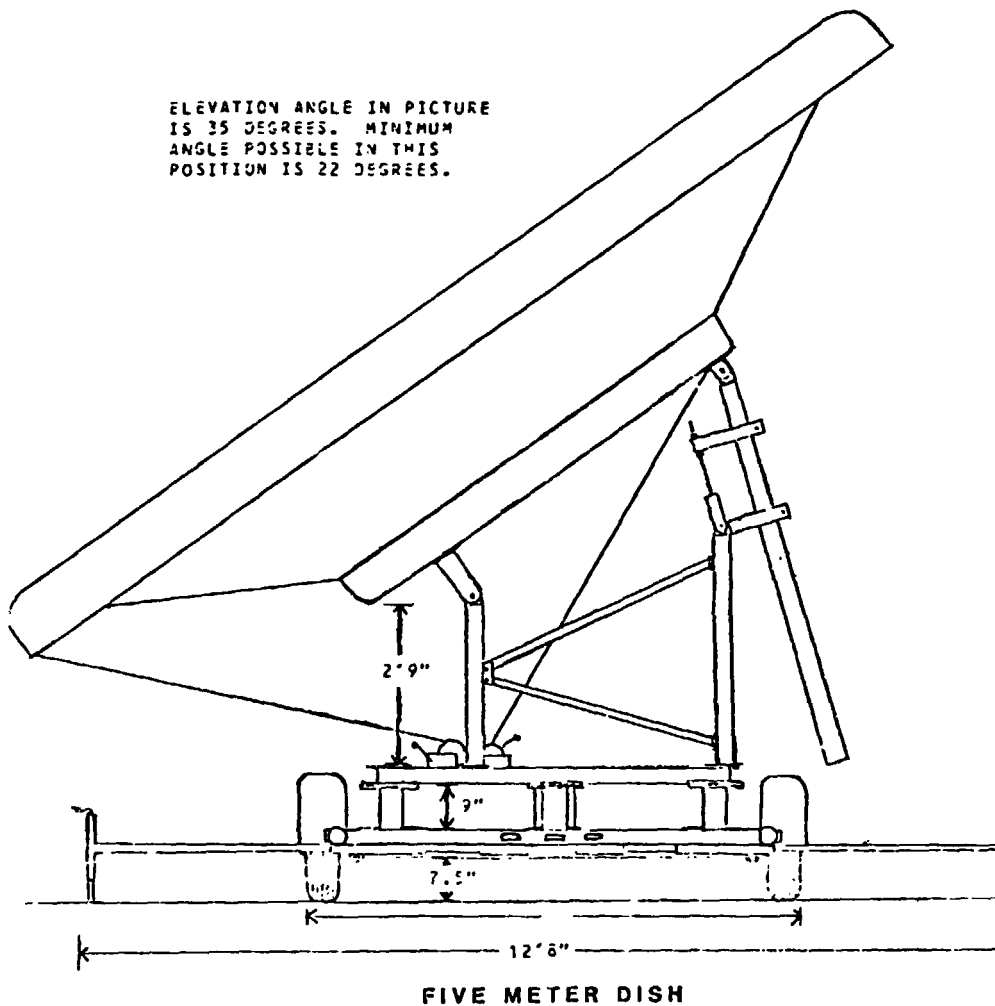

Figure 2.- Thin Route Project.

ORIGINAL DRAWING
OF POOR QUALITY

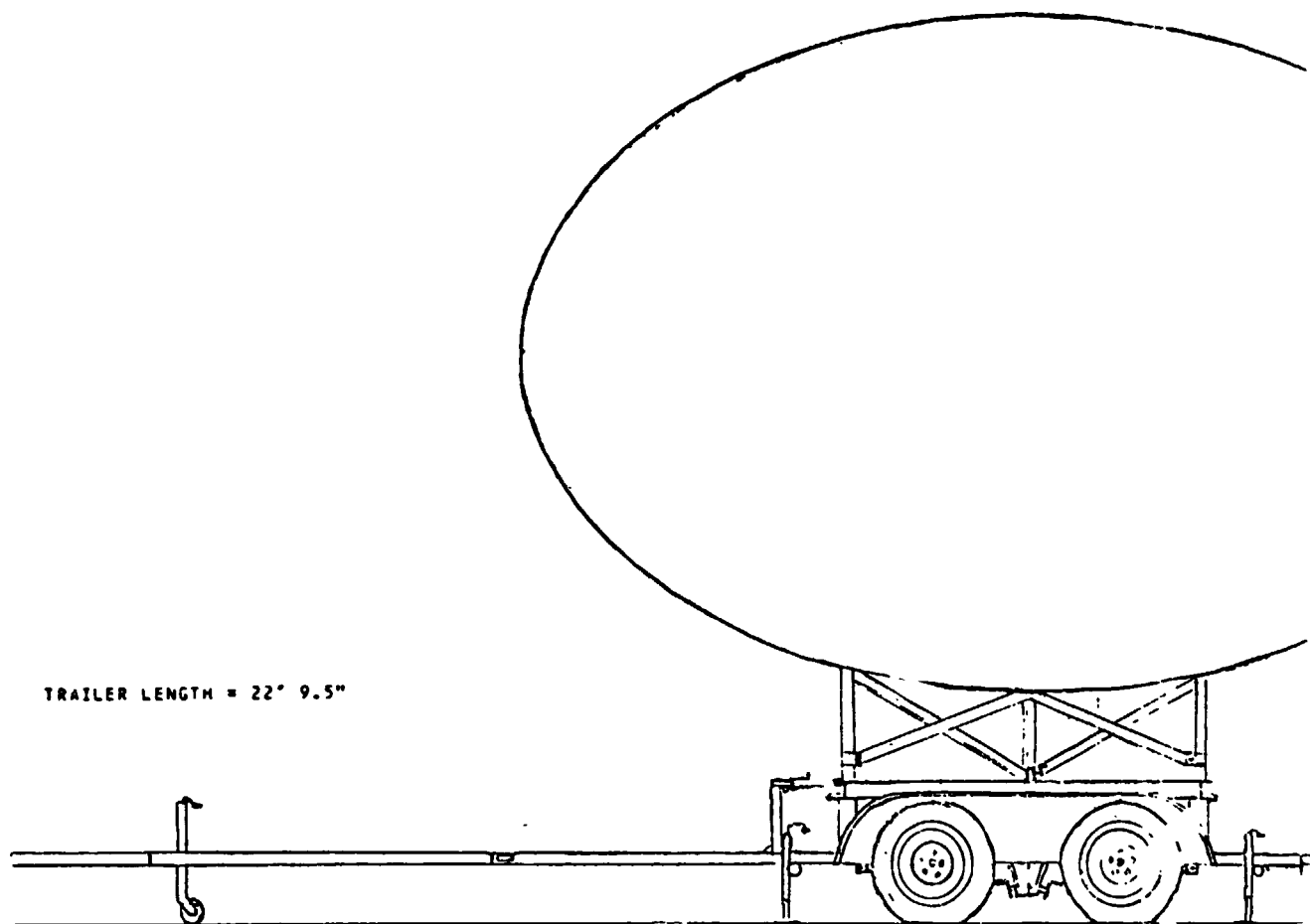

Figure 3.- Thin Route Project.

JOB DESCRIPTION

Yvette Hall

Before I began working in the Biomedical Research Center, I had no idea what my job would bring me in contact with. Before I started, my supervisor, Patricia S. Cowings, Ph.D. Research Psychologist, explained that she and her colleague William B. Toscano were teaching potential motion sickness sufferers to suppress their motion sickness symptoms. But, motion sickness does exist and it can detract from a person's performance effectiveness. Cowings and Toscano together have established that an autonomic conditioning procedure can achieve autogenic stimulation significantly faster than can be achieved through naturally occurring adaptation alone. Hence, our group analyzes motion sickness and how to control it with AFT, the new improved version of biofeedback.

From the first day of work, my job had led me to become involved in virtually every aspect of my group's research. One of my first duties was to input previous collected data into the files of the group's computer. These data were collected from various experiments conducted by the group's studies on how to control motion sickness with the use of autogenic feedback training (AFT).

Another major aspect of my job involves the tedious, but necessary, editing of data collected over the past 8 years. Currently, I have examined two experiments which involved various people who were placed in the Coriolis Sickness Susceptibility Index (CSSI) or VARD test. (The VARD test consists of placing a subject in a drum which moves in an upward and downward motion until he is sick, while simultaneously monitoring his vital signs.)

So far my job has been very exciting and challenging. It has led me from the private library located on the NASA Ames facility to the CSSI and VARD simulators. I have been treated as an intelligent and responsible employee and not as a mere "teenager." Everyone has accepted my presence and is very willing to answer questions or help with any problem. I have also been allowed to explore, learn, and become involved with our nation's space program by taking part in many of my group's previous and current studies which play a major role in space travel.

From what I have experienced so far, I believe that my decision to take this job has enabled me to become aware of what the "real world" is like, and what it requires from a person. Even though the program has not ended, I feel that my taking part in the SHARP program will be a memorable and rewarding experience.

WHAT IS BEING DONE TO CONTROL MOTION SICKNESS?

Yvette D. Hall

Since the beginning of our nation's space program, motion sickness has been a major problem. Historically, our understanding of motion sickness has been built from bits of truth, anecdotes, quackery, misconceptions, and old wives' tales. Actually, motion sickness takes its place alongside other human medical problems like pregnancy and the flu; everyone has been personally affected by it and everyone thinks that he or she knows the symptoms. This has been the main theme of my work here at the Biomedical Research Division at NASA Ames Research Center, Moffett Field, California, while under the supervision of Patricia S. Cowings, Ph.D., and her colleague William B. Toscano. Their research consists of teaching potential motion sickness sufferers to suppress their motion sickness symptoms. Motion sickness is being studied because it does exist and can detract from a person's performance. Thus, Cowings, Toscano, and and coinvestigators together have established that an autonomic conditioning procedure, autogenic feedback training (AFT), enables a human subject to adjust to repeated nauseogenic stimulation significantly faster than can be achieved naturally through adaptation alone (ref. 1).

AFT involves practicing a series of mental exercises to speed up or slow down the control of autonomic activity. This produces a reduced tendency for autonomic activity levels to diverge from baseline (at rest) under stressful motion-sickness-inducing conditions. Subjects engaged in applying AFT exercises are required to closely monitor their own bodily sensations during motion-sickness-eliciting tests. These tests include the Coriolis Sickness Susceptibility Index (CSSI), which consists of sitting a subject into a rotating chair that moves at various speeds while a visual background turns at differing speeds and directions, and the Vertical Acceleration Rotation Device (VARD) test, which involves the placing of a subject in a drum that moves in an upward and downward motion until he or she is sick, while simultaneously monitoring the subject's vital signs. These tests provide investigators with evidence of slight changes in autonomic activities such as increases in heart rate, skin temperature, and sweat (ref. 1). All of these symptoms occur in subjects that experience bodily weakness and discomfort with the onset of motion sickness.

Many subjects in AFT training have reported that the training has enhanced their ability to discriminate between minor changes in their autonomic activity levels. Data collected from various experiments have implied that AFT brings on learned self-regulation of autonomic activity levels which result in fewer severe motion sickness symptoms. By learning to control their physiological responses, many subjects are disrupting the perseveration of symptoms. An interesting hypothesis found during a study on motion sickness tolerance across six CSSI test of AFT, an alternative perceived task, and a no-task control concluded that:

1. The AFT group could withstand the stress of CSSI acceleration significantly longer and at higher rotational velocities than subjects performing either an alternative preconceived task, or the no-task control.

2. Subjects performing an alternative preconceived task and the no-task control would not differ significantly.

3. Subjects who received AFT will continue to improve in performance across the tests despite changes in the direction of rotation (ref. 2).

HOW AFT WORKS

AFT, autogenic feedback training, consists of a subject's use of self-suggestive exercises or mental images which are associated with the body's autonomic responses to induce activity within his or her own autonomic nervous system. The mental exercises of autogenic therapy combined with the "immediate" information about one's body provided by biofeedback enable a person to control several different physiological responses simultaneously. For example, let's say that you were lying on a bed and I placed electrodes on your arm to measure muscle activity. If I then asked you to think about the movements associated with throwing a football, I would notice that my measurement of your muscle activity had increased in the region where the muscles associated with throwing a football are located despite the fact that you were lying perfectly still!!! (See ref. 1.) In actuality, your nervous system began to stimulate (prepare) your body to throw that football when you simply thought about doing it. AFT teaches individuals to suppress their motion sickness symptoms. If the subject develops cold, clammy hands, AFT teaches him to have warm, dry hands. If the subject's breathing becomes irregular and his heart rate speeds up during a CSSI test, AFT teaches the subject to make his heart rate slow down (ref. 1). Studies over 10 years of experimental development of AFT on scores of aircrews and nonflyers alike have proven that this training regime is one in which virtually anyone can eventually learn to control, if not entirely eliminate, their own motion sickness symptoms (ref. 3).

As a member of this biomedical research team, I have been involved in virtually every aspect of my group's research. One of my first duties was to input previous collected data into the files of the group's computer. These data were collected from various experiments conducted by the group's studies on how to control motion sickness with the use of AFT. I also was allowed to watch the various tests performed on the subjects who commonly are pilots and/or astronauts. During the second week of my job, an astronaut was tested on the CSSI. He eventually experienced the "classic" textbook progression of symptoms that a motion sickness victim experiences. These symptoms can vary from yawning or sighing to the actual nausea and vomiting.

Another major aspect of my job involved the tedious, but necessary, editing of data collected over the past 8 years. I have examined two experiments which involved various people who were placed in the CSSI or VARD test. Once the data had

been edited, I then generated graphs of the subject which consisted of the data collected from his baseline (at rest) run, his in-motion (CSSI or VARD) run, and after testing ended.

FINDINGS ABOUT AFT AND MOTION SICKNESS

The research at this laboratory has exploded some old myths and supported others. To date, the accumulation of data at NASA indicates:

1. Subjects who had AFT can withstand Coriolis acceleration over a significantly longer time and at higher velocities than those who had no AFT.
2. Regardless of their histories, persons with high or low susceptibility to motion sickness can derive comparable success in controlling their symptoms with the aid of AFT.
3. Historically, women have been reported to be more susceptible to motion sickness than men. But in well-controlled NASA settings, women can use AFT to suppress their symptoms as well as men.

If you learn to control your symptoms during Coriolis acceleration, you can also control them during other types of motion sickness tests like visual stimulation or linear acceleration. Other motion sickness remedies (drugs included) have not yet demonstrated this capacity for "transferring" to several different stressful situations. The implication of this is that AFT may also be effective in combating the symptoms of zero gravity sickness in space (ref. 1).

AFT provides a powerful avoidance strategy by enabling subjects to regulate their own physiological and behavioral responses to stimuli that elicit motion sickness. Various experiments demonstrate that both highly and moderately susceptible subjects who receive AFT are able to adjust to repeated nauseogenic stimulation at similar rates, and individuals who receive AFT increase their tolerance to motion sickness significantly faster than other subjects without the training (ref. 3).

In the course of developing this autonomic conditioning procedure, our research group has collected a large, heterogeneous data base containing the physiological stress profiles of a wide population of human subjects under several different nauseogenic stimulus conditions. Statistical analyses of the physiological data are presently unavailable. However, once this analysis is complete, it may be possible to identify specific characteristics of individual stress profiles that are related to factors such as susceptibility, adaptational capacity, sex, age, and propensity for learning visceral control. This work will probably have application for development of predictive criteria for susceptibility to the unique stimulus conditions of zero gravity in space. Eventually, nearly anybody can learn to control motion sickness symptoms through AFT, but people vary greatly in their rate of learning.

In conclusion, I feel that my job here at the Biomedical Research Division has been very interesting. It has led me from the private library located on the facility to the CSSI and VARD simulators. It have been treated as an intelligent and responsible employee, and not as a mere "teenager" or "go-fer." My group has allowed me to explore, learn, and become involved with our nation's space program through their helpfulness and constant guidance. From what I have experienced, I believe that my decision to take this job has enabled me to become aware of what the "real world" is like, and what it requires from a person. Even though the program is not quite over, I feel that my taking part in SHARP has been a very memorable and rewarding experience.

REFERENCES

1. Cowings, Patricia S., Ph.D.; and Malmstrom, Frederick V., Ph.D.: What you thought you knew about motion sickness isn't necessarily so. *Flying Safety*, Feb. 1984.
2. Toscano, William B.; and Cowings, Patricia S.: Reducing motion sickness: A comparison of autogenic-feedback training and an alternative cognitive task. *Aviation Space Environmental Medicine*, vol. 53, no. 5, 1982, pp. 449-453.
3. Cowings, Patricia S., Ph.D.; and Toscano, William B.: The relationship of motion sickness to learned autonomic control for symptom suppression. *Aviation Space Environmental Medicine*, vol. 53, no. 2, 1982, pp. 570-575.

JOB DESCRIPTION

Sadie Hathorn

When I received confirmation that I would be working at NASA this summer, I knew it was going to be a wonderful experience. Fortunately, I get to work with Jim Aguilar and Greg Felix, who are also in the SHARP program. Our main supervisor is Bob Gibson, but we also work with Skip Gross, a senior engineer, and with Roger Bjorkstrand.

My day is divided into two parts. The first part of the day all three of us work with Roger. We are equipment verification officers. Or at least that is what we are supposed to tell people. In actuality, we count phones, terminals, and jacks. The information that we obtain will be put into a computer system and when people request a phone or a terminal, we will know exactly where the jack is and how many they already have.

Although I work in telecommunications, I feel that in the morning I am not learning anything; this is one of the not-so-good aspects of research. But the work that I am doing will help others.

The second half of the day is more enjoyable. Every other day one of us gets to use an Osborne Executive computer. During our computer time we work with Bob. We are learning how to set up a computer and different variations of BASIC.

The other thing we do in the afternoons is work with Skip. Skip is teaching us a lot about communications with satellites, electronics, and physics. Also working with Skip are four other people, Al, Wes, Mike, and Mark. Al and Wes are engineers. They use equipment and also design equipment like spectroanalyzers to help track satellites. We are often asked to solder equipment together, assemble a component, or to take something apart so they can use the parts.

Mike Koop and Mark Leon are college students majoring in electrical engineering. We work more directly with them. Mike and Mark are the ones who actually showed us how to do all the things that have to do with mechanical and electrical engineering.

My building has to be one of the most free-spirited, yet hardworking, buildings on the base. Everyone is so friendly and they try so hard to make us happy. I think this is going to be a very worthwhile summer and I'm sure I will enjoy it a great deal.

REPRODUCED FROM THE NASA ARCHIVE

COMMUNICATIONS¹

Sadie Hathorn

How would you feel if you lived in a place where there were no communications, no medical help, and very few supplies? For you and your people time would stand still, while the rest of the world progressed at an uncontrollable speed.

Twenty years ago, this was how people in places like Africa, the Pacific Islands, and parts of Alaska lived. They rarely had communication with the outside world. The only communication they had was with a supply plane or supply ship which arrived every 2 months to twice a year. These supply vessels never came close to the islands. The planes would drop packages from the air and the ships would send a little inflatable raft out and someone from the island would take their boat out and go get it. They also had no medical supplies or help. A broken leg or even flu could lead to death, and several times this happened.

Just think how long these people lived like this before someone decided to help them, which was in 1964. This is when a government-owned agency called Health, Education, and Welfare (HEW) proposed to do something about this. INTELSAT, which is the only organization used for international telecommunications and satellites, was asked to set everything up.

The method INTELSAT was going to use dealt with the channels on a television set. There are 24 channels. There are 12 transponders with two channels each, one channel even and one odd. They would give each area their own transponder to communicate with. The only problem was their transponders would cost a million dollars each, and the countries could not afford this.

So instead of using that system, NASA sent up six Applications Technology Satellite (ATS) satellites and let all the countries share the whole band. This worked fairly well. The countries set up small communication stations where they lived. People were sent over to help them do this.

They also had direct communication with the Twin Cities: Minneapolis and St. Paul. These cities provided the medical aid the countries needed. Doctors were on call 24 hours a day. Calls came in up to 10 to 12 times a day. Medically trained people were sent to the areas which needed help or the people were instructed on what to do. The only problem with this was using the whole band. If two emergencies came up at the same time, the one of the most importance would be taken first.

These satellites had a life span of 1 year; but because of the way they were made, a couple of them still work today. But these are slowly dying.

NASA was to develop a new system of communications to replace the dying ATS satellites. The project was taken to the Telecommunications Branch.

This NASA project is called Thin Route. The purpose of Thin Route is to provide low-cost communications to third-world countries. NASA can develop a system that will cost only twenty thousand dollars. This way the countries can afford the system and have money left over for other purposes.

There are two main parts that are used. There is the ground station and the MATE van.

The ground station is a transmitting and receiving station. The information it receives is from satellites and the information it transmits is to satellites. They plan to set up three ground stations. One in Alaska, one in the Pacific Islands, and one in Africa.

The MATE van consists of the actual van and dishes, which are located outside the van. The dishes pick up radio waves, send information, and receive information from satellites. Inside the van is all the technical equipment. The equipment processes and analyzes information received by the dish.

One very important piece of equipment that is located in both the MATE van and the ground station is a spectrum analyzer. The one in the MATE van cost thirty thousand dollars. The purpose of a spectrum analyzer is to take any frequency modulated (FM) signal and display it on a Cathode Ray Tube (CRT). It has the ability to magnify or minimize different aspects of the frequency. It also has the ability to interpret radio signals used for telecommunication purposes.

Jim, Greg, and I have done a lot of work for the Thin Route project; Greg does most of the work outside with the van and dishes, while Jim and I work inside the ground station.

One of the jobs Jim and I had was to assemble an echo canceler. When people are talking to other people in a room, the echos can be very bothersome and confusing. So an echo canceler cancels out all the echos.

We are also asked to create a winch design to be used with the dishes. The dishes are capable of being used alone, but they also have extensions that can be added on. The bigger the dish, the more frequency you can pick up. The extensions are very heavy, so we were asked to design a winch so people wouldn't have to do this manually. We were also asked to design a support for the winch itself.

We were also asked to put together an audio spectrum analyzer. This picks up an audio range of frequencies and interprets visual display. It also has the ability to magnify and manipulate the frequencies that are entered in the screen.

This part of our day has to be the most interesting. The amount of physics and engineering we are learning is wonderful.

We do have another part to our day. We work with equipment verification. We check all the phones and terminals on the base. All this information will be put into a large computer system and used to organize the information. Now if anyone

puts in a work order for a phone or something else, they will know where everything is and all the information about the phones and terminals.

My work is very enjoyable. Although the pay is not that much, the experience is overwhelming. I'm sure I won't regret it at all by the time it's all over.

FOOTNOTE

¹This information was obtained through lectures given by Brad Gibbs, Skip Gross, Mark Leon, and Mike Cooper.

JOB DESCRIPTION

Cynthia Hwang

Although I faced responsibility before--through a tutoring assignment at school--I was not fully prepared for my job at NASA Ames. Similar to school, I discovered that the lessons of life came in both forms, good and bad, and my job at NASA exposed me to both of them.

As I stated before, I had accepted responsibility by regularly tutoring math students at my school. But the SHARP program held few other likenesses. It was to be my first regular schedule, five-day-a-week job, a difficult enough obstacle because of my fondness for sleeping late. Personal free time sharply dropped, and I found myself missing time I had otherwise taken for granted.

My first day of work introduced me to my supervisor, Dr. Bruce Smith, and other workers and fellow students at Building 245. Because the situation was hectic, my permanent assignment was replaced with a variety of temporary ones. Yet eventhese caused me to learn something. My first two days were spent struggling over a challenging math equation and its resulting graph. I learned from that problem a little of the theory of the origin of a star and its solar system.

The next few days, I experienced the tasks and challenges of being an electrical engineer, as I drew wires through the entire building and traced previously placed wires. I became acquainted with more people, and I became more familiar with the feeling of boredom. But the experience did teach me that I would not enjoy becoming an engineer, at least not an electrical engineer.

I also did a bit of typing, but this also taught me something (besides discovering that I did not want to become a secretary). I found out about various documents Dr. Smith wrote, and because he is involved in my hoped-for field, astronomy, it was not a terribly monotonous chore. I learned of current theories and a bit of the responsibility involved.

Presently, I work for Dr. Chris McKay. Again, I experienced some monotony as I counted blips from an accelerometer, a task I am currently still involved in. Yet again, I am learning. I have become acquainted with computers and computer programming. As computer science is the field both my parents are in, it has always been a possibility for me; but I found out that although I can communicate with and comprehend them, it is not my chosen field of education. FORTRAN is slowly, but surely, seeping into my head, accompanied by the ability to program graphs to graph the results from my counting accelerometer blips.

But my job at NASA has been a learning experience as I expected, and I have yet to dread coming to work. Counting blips is not exciting, but when the Jupiter probe descends through Jupiter's outer atmosphere, sending back information to distant Earth, I wil' be able to state proudly that I played a role in it.

GALILEO

Cynthia Hwang

Presently, one could name many reasons for mankind's interest in space exploration. To every country, space represents a modern frontier, akin to the exploration of the New World in the late sixteenth and early seventeenth centuries. By studying the heavens, people are seeking new resources to replace the exhausted supplies on planet Earth. Another reason for the interest in the surrounding universe is the continuous quest for life with origins outside those of Earth. But the most important factor of mankind's fascination is a search for knowledge, not for natural resources or a foreign civilization, but a thirst for the origin of the universe and therefore the origin of mankind.

Scheduled in April 1986, the National Aeronautics and Space Administration (NASA) will launch one of their now-famous space shuttles. Aboard will be Galileo--in a fashion, NASA's answer to some of the questions raised by inquisitive scientists.

The Galileo consists of two main parts: a Jupiter orbiter and a probe. After a 1000-day journey, the Galileo will assume orbit around the giant planet, an orbit which will last for 200 days, in the hopes of astronomers. The orbit will carry the Galileo past its four Jovian satellites--Io, Europa, Ganymede, and Callisto--a combined total of 11 times. This will enable scientists to study the atmosphere of not only the largest planet in the solar system, but its large moons as well.

Sometime in August of 1988, the Galileo will approach Jupiter and begin its important activities. Fifty-six days away from planetary encounter, the Galileo will release the probe which will continue the trip to Jupiter and enter the atmosphere. As it descends through the atmosphere, the probe will unfurl a parachute to slow its speed as it broadcasts information back to the waiting orbiter, which will in turn relay it back to the waiting scientists on Earth. The probe's descent time is expected to be approximately 15 min before Jupiter's pressure and heat overwhelm the probe's protection. However, scientists are hopeful that the probe will survive longer than 15 min, possibly up to 60 min.

The probe will enter the upper atmosphere of Jupiter, traveling at the tremendous speed of about 48 km/sec. It will enter at an angle between -7° and -10° relative to the horizontal. A steeper angle could overheat the probe on entry and overheat instruments. In fact, a majority of the probe's weight consists of a heat shield to prevent the probe from burning up in the atmosphere.

As the probe reaches peak deceleration, it will be subjected to a 400-g force--400 times the Earth's gravity. After deceleration, the probe will release its parachute and begin measurements, and the aft cover and aeroshell (the probe's protection for entry) will separate from the main module.

Aboard the Galileo Probe are a variety of instruments, including the neutral mass spectrometer (NMS), which determines chemical composition, and the net flux radiometer (NFR), which determines the ambient thermal and solar energy as a function of altitude (ref. 1).

One of the major instruments aboard the probe was the atmospheric structure instrument (ASI). It was programmed to determine the temperature, pressure, density, and molecular weight. Another of its purposes is to measure the atmospheric turbulence.

Under Dr. Chris McKay, I assisted with interpreting data. Information relayed by the Galileo Orbiter concerning atmospheric turbulence will consist of numbers. Using a random generator, readings were formed. These readings resembled the output created by a seismograph. Counting the "blips" at different levels of the graph, numbers such as those to be sent back by the Galileo could be formed. The numbers were then compared with the results from the laboratory ASI. From there, ranges and averages of the turbulence could be discerned.

My job involved counting the resulting blips from the random generator and accumulating the data. Meanwhile, I became acquainted with the TERAK terminals, file editing, and computer relations. I also learned FORTRAN.

After accumulating the data, I was assigned the task of graphing the results of different levels at 16-sec intervals over a total time period of 4 min. I wrote a program which accomplished the above and, in addition, computed and graphed the average.

I assembled the graphs and data. I then added to them a data chart and a short explanation of the meanings of the graphs and the data. Altogether, the job lasted 3 weeks, which I feel were extremely worthwhile and satisfying.

My favorite part of the SHARP program will arrive--hopefully--in April of 1986 as the Galileo begins its journey to Jupiter. I will never regret my job as the Jupiter probe begins to send back information that will enable me to remark, "I was a part of that!"

REFERENCE

1. Johnson, T. V.; and Yeates, C. M.: Return to Jupiter: Project Galileo. Sky and Telescope, Aug. 1983.

BIBLIOGRAPHY

Clark, T. C.; and Yeates, C. M.: Galileo: Mission to Jupiter. Astronomy, Feb. 1982.

McKay, Chris: personal interview.

Engle, Michael: Astronomy from the Shuttle. NASA Document.

The Universe (copyright date 1971). Nature Library.

Astronomy. World Book Encyclopedia, 1983.

ORIGINAL PAGE IS
OF POOR QUALITY

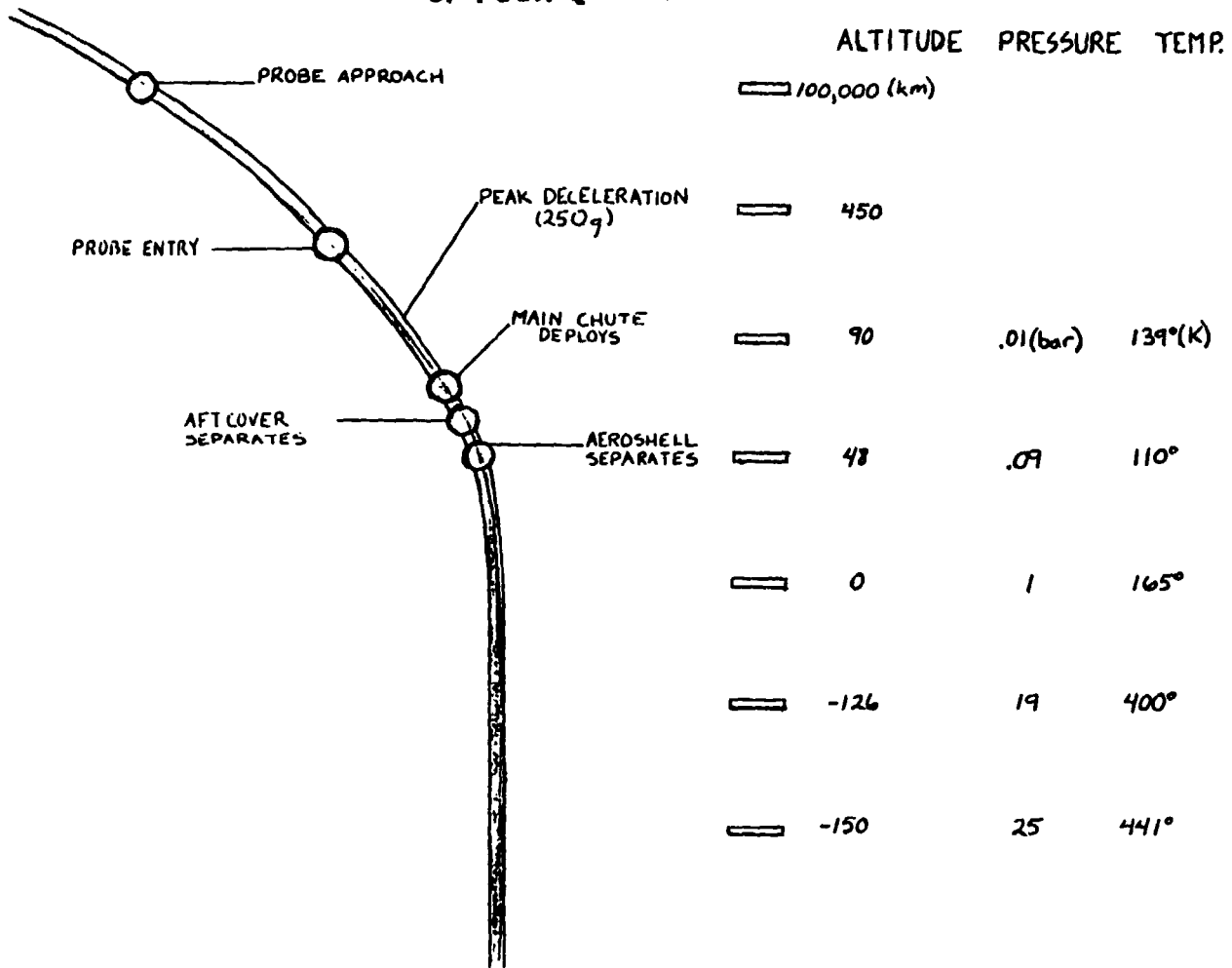

Figure 1.- Probe entry of Jupiter.

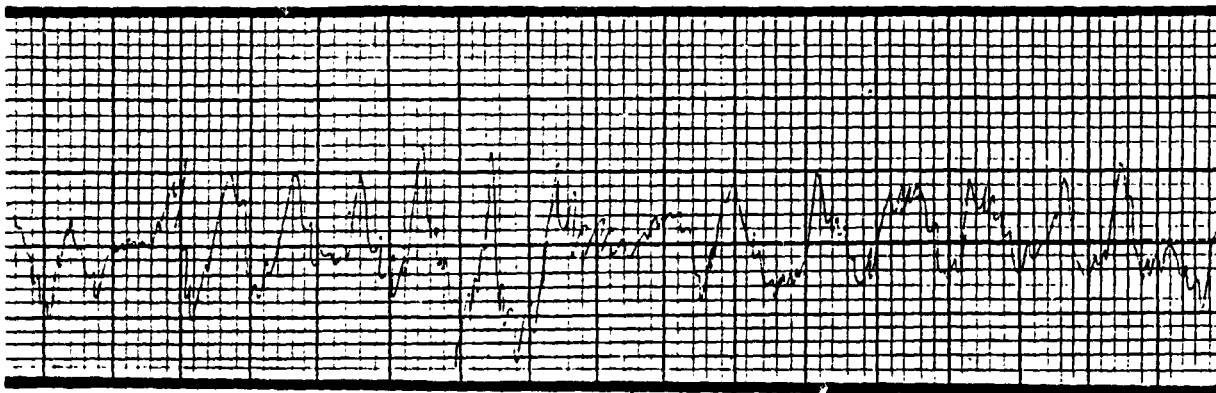

Figure 2.- Sample accelerometer reading.

JOB DESCRIPTION

Gloria Kao

To Commander Powell:

I have successfully penetrated the security shield of Chemical Research Projects Building 223. At present, I am under the supervision of Dr. Robert Rosser who has assigned me to work with Dr. Ming-Ta Hsu in the lab. My coworkers' helpfulness and friendliness makes learning and gathering information on sensitive projects possible.

An aircraft's exterior is made of soft, lightweight aluminum. To avoid any frame damage, its interior is lined with panels made from a honeycomb sandwiched between two pieces of fibers painted with resin, or face sheets. Our goal is to find the least flammable resin that does not give off toxic gas in case of a fire hazard.

Each day, I participate in the process of dissolving the correct amount of resin in solvent, and painting the fibers. I also do an infrared scan to find out the function groups present in the resin. More tests are done on the resin by using the Du Pont Thermogravimetric Analyzer 1090 to calculate the weight loss percentage after burning at high temperature.

Not only am I learning in the lab, I am learning outside the lab as well. Dr. Rosser has taught me how to use the chemical resource books in the library. Sometimes I will be sent to research on a particular compound (perfect time for finding a drop site). Dr. Rosser has also been informing me of the realistic expectations from various careers. His knowledge has helped me to see careers in a whole new light. I am now better equipped to make a career decision in the near future.

My mission has proceeded smoothly for the past 4 weeks. No suspicion has arisen from my coworkers. I have adapted to my new environment well and am making progress daily. I expect to fully benefit from this 10-week program. Until then,

Sincerely,
Agent Triple-0-Seven
0007

PRECEDING PAGE BLANK NOT FILMED

AIRCRAFT SAFETY IMPROVEMENT

Gloria Kao

Since the invention of aircraft, men have sought ways to improve it. One of the projects at the Chemical Research Projects Office at NASA is to ameliorate the danger of flying an aircraft. Dr. Robert Rosser, my supervisor, and Dr. Ming-Ta Hsu, the lab director, are both very much involved in this project. This exciting research has been going on for 5 years. The estimated cost is one million dollars to date.

When a fire hazard occurs on an airplane, what most often kills a passenger? It is the toxic gas given off by the burning panels that pad the inside of an airplane. The researchers have been trying to make an optimum panel, one that is light, strong, economical, flame retardant, and that will prevent toxic gas emission.

A panel is a honeycomb sandwiched between two pieces of fibers coated with resins. The resins serve as glue. The present panel uses glass epoxy fibers. Studies have shown that epoxy is not the best choice. The future panels will use graphite fibers, which are less flammable. Graphite fibers are 30% lighter than the glass epoxy fibers. Furthermore, they do not give off toxic gas when they burn.

Why does an aircraft need panels? The purposes of the panels are comfort and decoration, which are important for commercial airlines battling for customers. The panels cover up the less attractive parts of an airplane such as the pipes, wires, and so on. Paint can be sprayed on the surface of the panels to make them more attractive.

The procedures of making panels are:

1. Dissolve the resin in the correct solvent.
2. Place a piece of fiber on a heavy metal plate.
3. Coat the fiber with the solution. Let it dry.
4. Heat the fiber at 110°C for 20 min in the oven.
5. Press the plate along with the fiber in the presser at desired temperature and pressure.
6. Remove the face sheet.
7. Adhere the face sheet to the honeycomb.
8. Press the panel at the desired temperature and pressure.
9. Remove the panel.

Each component of the panel is used for a particular reason. Because a piece of fiber comes apart easily, resing is used to hold the fiber together. Why is resin preferred? The reason is easy processing. Face sheets are used to protect the honeycomb from physical damage and fire hazard. Honeycomb is chosen for its ability to withstand a tremendous amount of pressure with a relatively small mass. These materials' special properties make them suitable for the project.

Scientists have come up with a superior panel. It does not emit toxic gas. This new panel is stronger. However, it costs \$84/ft² which is three times the cost of the old panel. Researchers hope to reduce the cost. Even without reducing the production cost, they still believe that the new panels will prove to be economical in the long run.

Besides the production of panels, researchers also test the properties of different resins. These test instruments include Thermogravimetric Analyzer (TGA), Differential Scanning Calorimeter (DSC), Limiting Oxygen Index (LOI), and Infrared Spectrometer (IR Spectrometer).

TGA: The Du Pont 951 TGA reveals what mass percentage of the original sample has remained after a high-temperature burning. The sample is placed inside a platinum foil hanging on the internal balance. The machine converts the mass to a percent, takes data and plots the result graphically. A resin retaining a high percentage of its initial mass is preferred.

DSC: The Du Pont 910 DSC finds the cure temperature of a sample. The cure temperature is the temperature at which the heated substance has completely reacted, or burned. A sample with a high cure temperature is desirable.

LOI: This machine controls the ratio of oxygen to nitrogen. By varying the ratio, one can find the least amount of oxygen that is needed for a sample to burn. A high LOI means that burning will occur only when the atmosphere has a high concentration of oxygen. A low LOI indicates that a sample has a higher tendency to ignite.

IR Spectrometer: The Infrared Spectrometer is based upon the principle that each functional group absorbs a characteristic wavelength. This wavelength is used for identification of the sample. The percent transmittance indicates the relative amount of the functional group present in the sample.

The testing of the panels is done in the National Bureau of Standards Smoke Density Chamber. Percentage weight loss, smoke density, and mass optical density are measured.

Scientists at the Chemical Research Project Office are working to improve the efficiency of aircraft. Their findings no doubt will benefit the aircraft manufacturers and certainly the public.

ORIGINAL PAGE IS
OF POOR QUALITY

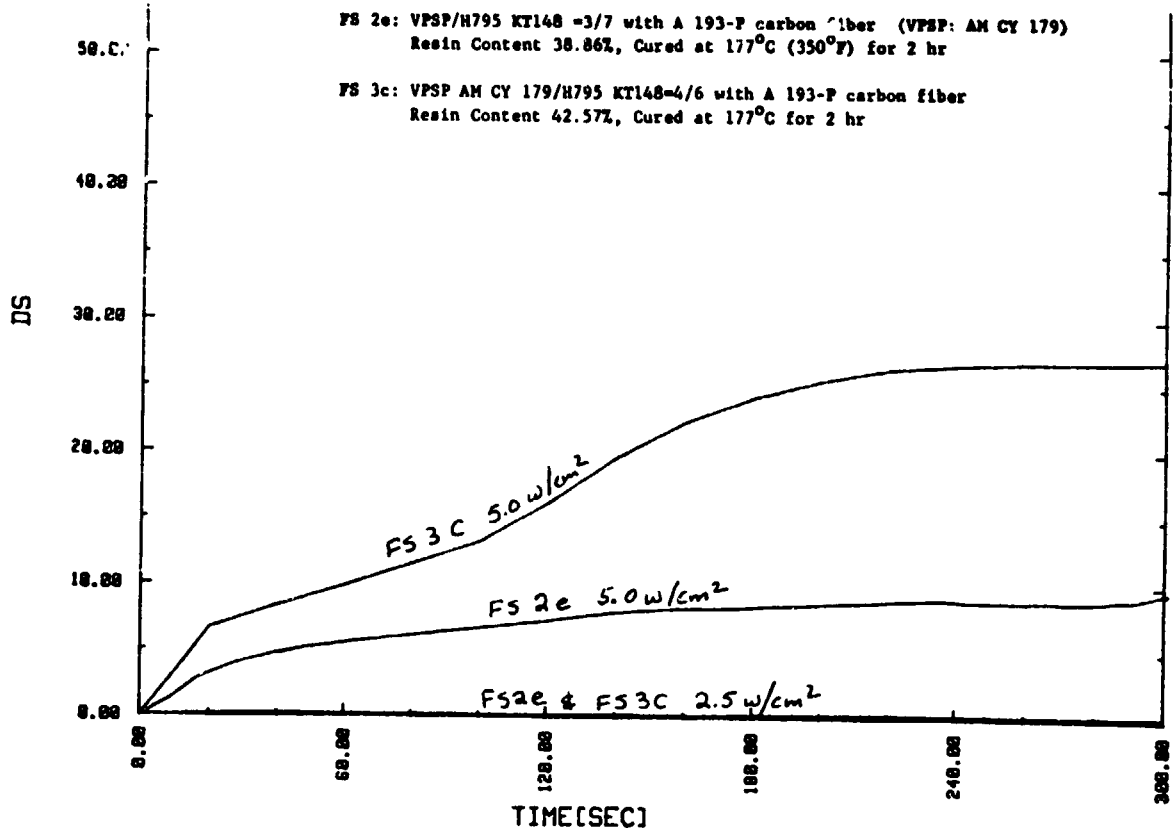

Figure 1.- Smoke density at 2.5 and 5.0 w/cm².

Sample: HC888-D
Size: 4.8
Rate: 10
Program: Interactive DSC V2.0

DSC

Date: 18-Jun-84 Time: 11:30:20
File: HC888D.01 DSC-16-HC
Operator: KAO
Plotted: 18-Jun-84 12:41:20

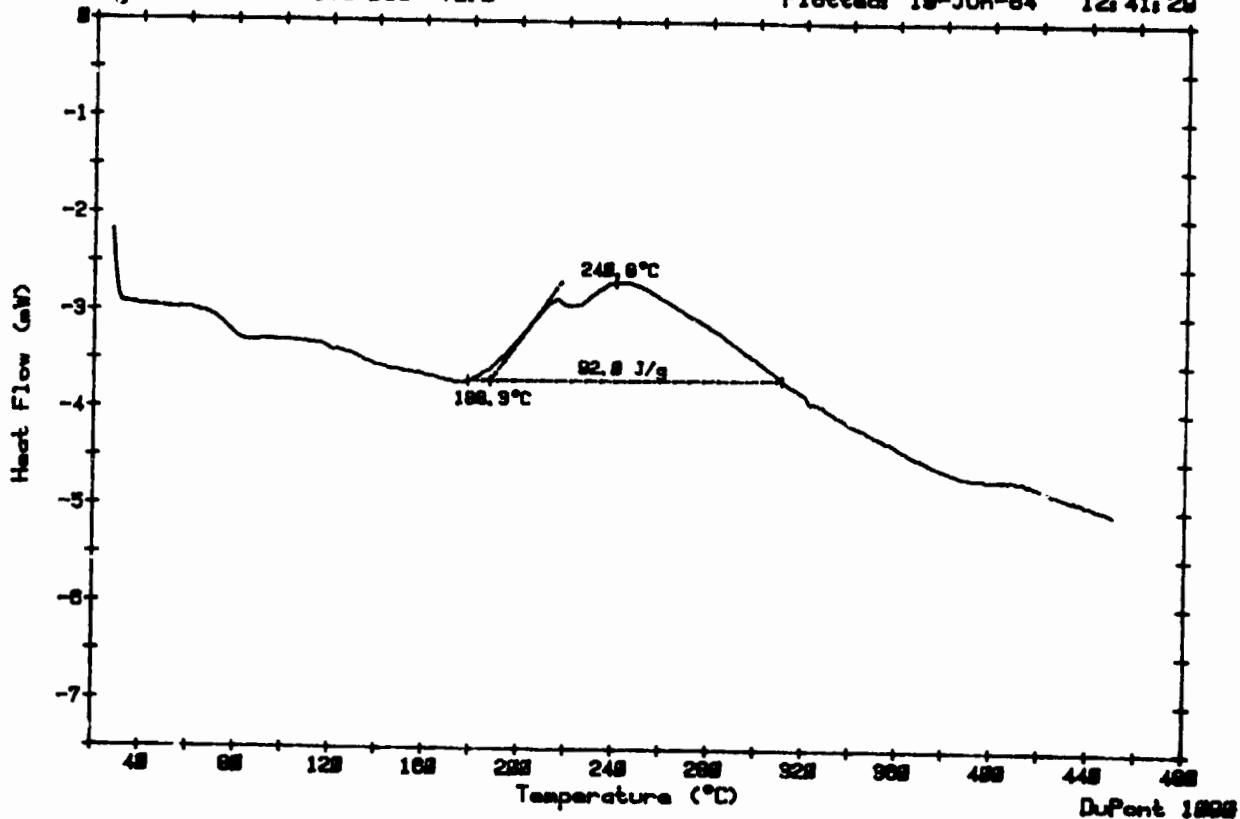

Figure 2.- DSC.

ORIGINAL PAGE IS
OF POOR QUALITY

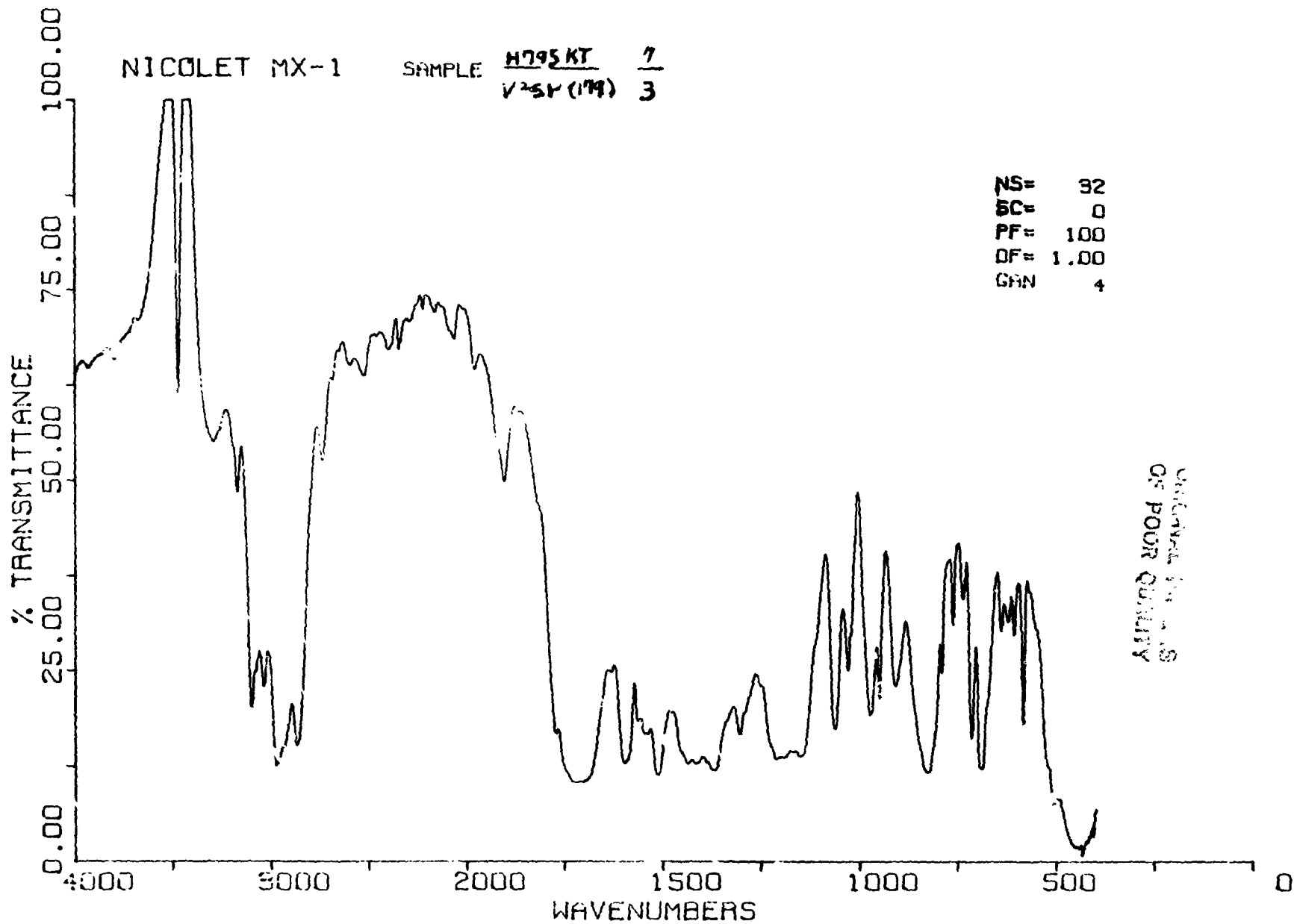

Figure 3.- Nicolet MX-1.

ORIGINAL ...
DE POOR ...

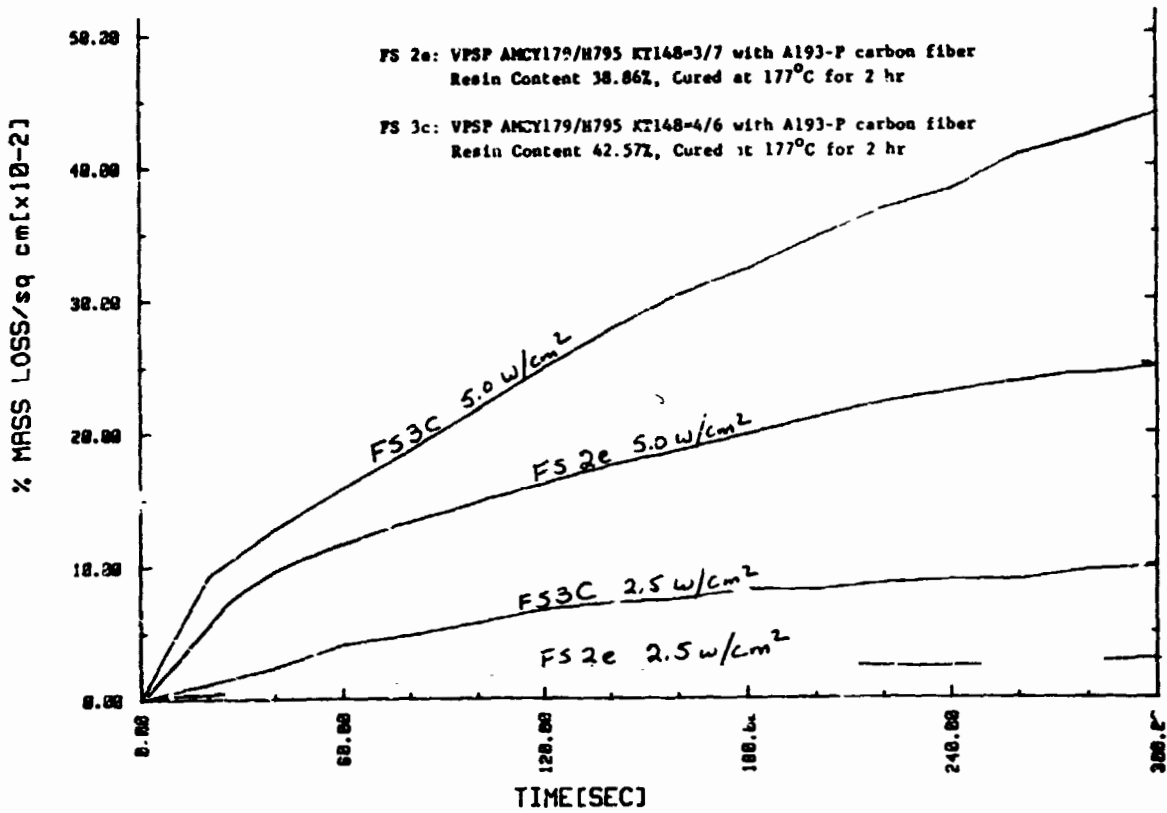

Figure 4.- Percent weight loss at 2.5 and 5.0 w/cm².

JOB DESCRIPTION

Kenneth Ko

Before I started work in the Extraterrestrial Research Division, I feared that I would be spending all my time investigating recent U.F.O. sightings, but to my delight the work is far more practical and meaningful. Currently, Dr. Robert Wharton, a research scientist, is entertaining the idea that if a closed life support system is found feasible, then the dream of long-term manned spaceflight (without storing massive quantities of food) could be made a reality.

Now, how does an electrical engineer work his way into this most intriguing experiment? Well, Dr. Wharton is running an experiment with algae, representing the plant component, that requires constant measurements of the O_2 (%), CO_2 (%), photocell (volts), pressure 1 (torr), and pressure 2 (torr), as well as a way to control these factors; an engineer's expertise is needed to accomplish these difficult tasks.

On my first few days at the job, I was apprenticed by Xoung Tu, a student majoring in electrical engineering, and we constructed a circuit board to control the photocell (volts) in the experiment. However, recently I have been under the learned guidance of Chris McKay, a computer expert, who has started me on a program that will eventually perform all of the aforementioned functions. Ironically, this program will make the controller that Xoung and I worked so hard on obsolete, but it is all in the name of progress, right?

Besides the computer program, I also am learning how to use EDT, a method of editing on the VAX/VMS computer, whenever I have any spare time. Working at Ames has proved to be a most rewarding experience for me; all my coworkers and supervisors have been so helpful. I not only feel that I am learning a lot, but also that I am part of a tightly knit team.

PRECEDING PAGE BLANK NOT FILMED

THE CONTROLLED ECOLOGICAL LIFE SUPPORT SYSTEM

Kenneth Ko

Long-term manned spaceflight has been a dream of man ever since the first time he took to the air. In the beginning, this dream was just that--a dream--but now through improved technology and utilization of manpower the dream becomes more real every day. Interestingly, the questions that arose when this idea was first proposed are the same ones that are being asked today: how to maintain the amounts of food, water, and air required for survival? How to manage waste? How to control such a complex system? These are a few of the problems confronting a talented group of people working on the Controlled Ecological Life Support System (CELSS).

To address these problems a CELSS would have to be found that could convert waste water to usable water, waste products to food, and CO_2 to O_2 . Much research has been done on finding efficient ways to recycle water. As far as the food question, the CELSS program is testing the hypothesis that energy can elaborate simple inorganic molecules, such as CO_2 , O_2 , N_2 , water, phosphate, and sulfate, into complex organic molecules, such as sugars, proteins, and fats. Many scientists agree that eventually nonbiological food will become not only feasible but also economical. In fact, some food materials have already been made abiotically, and these methods are being studied within the CELSS program. However, for now the most reliable method of food production remains biological, and plants seem to be an answer. That is why experiments are being done with plants to examine their usefulness in a CELSS.

Due to differences in the assimilatory quotient (moles of CO_2 consumed/moles of O_2 produced) of an autotroph, and the respiratory quotient (moles of CO_2 produced/moles of O_2 consumed) of a heterotroph, atmospheric concentrations of O_2 and CO_2 in a CELSS are unstable. Therefore, a study of the dynamics, and also the possible control, of the gas exchange in a CELSS is being conducted. (The eventual goal of this study is to develop biological controls that can stabilize atmospheres.)

An experiment, under the supervision of Dr. Robert Wharton, is being run with algae, representing the autotroph, and mice, representing the heterotroph, in a controlled, gas-closed environment. Vital to Dr. Wharton is the following data: the photocell volts, the pressures (in torr) both inside and outside the system, and the O_2 (%) and CO_2 (%). What Dr. Wharton is most interested in is the rate of exchange of the O_2 and CO_2 because these data will present relevant information to the gas exchange study. The computer programs that I have written provide Dr. Wharton with the aforementioned data.

In any CELSS, control of many separate functions and independent parts is crucial. Thus, control is a major part of the CELSS program. Therefore, writing computer programs that serve to control Dr. Wharton's experiment is not only exciting, but also contributory to the overall program.

The overall goal of the CELSS program is to design a system with high degrees of efficiency and reliability, whereby all waste materials are recycled into usable supplies. After this goal is met, CELSS may be put into space and consequently open up endless opportunities for the future. I feel fortunate because not only do I have the privilege of witnessing history in the making on a firsthand basis, but also because I am an integral part in this history-making process.

BIBLIOGRAPHY

Moore, B., III; Wharton, R. A., Jr.; and MacElroy, R. D. (eds.): Controlled Ecological Life Support System: First Principal Investigators Meeting. NASA CP-2247, 1982, pp. 1-3.

JOB DESCRIPTION

Mousumi Majumdar

Although I have always had an interest in biology and biochemistry, I have never realized the kind of exciting research that was being done in this field. My position under research scientist Dr. Robert Wharton here at the Extraterrestrial Research Division at NASA has allowed me to learn many interesting aspects of this field.

Currently, I am working as an assistant to Dr. Wharton on a project concerned with Controlled Environmental Life Support Systems. The purpose of this project is to study the elemental cycles and biological factors that affect the transformations of nutrients into food, of food material into waste, and of waste into nutrients. Thus, although this involves a certain amount of knowledge of biochemistry and biology, it is ultimately concerned with the ecological aspect. Eventually, this project will allow humans and higher plants to be sent into space and live this kind of "mini-ecosystem."

Dr. Wharton's part in this project is an experiment involving the study of the exchange of materials between mice (heterotrophs) and algae (autotrophs). I am learning many interesting things, including much about algae, since Dr. Wharton is very knowledgeable about the different varieties of algae.

However, my exposure has not been limited to biological matters. In addition to the lab work, Dr. Wharton has been very helpful by allowing me to pursue my interest in computers. In fact, I am creating some files for the data that he has collected from his Antarctic algae samples.

While Dr. Wharton has allowed me to get involved and get a thorough understanding of this project and his experiments, he has also given me the independence to pursue my own interests. At the moment, I am conducting my own experiment, which deals with growing algae at different temperatures, constructing graphs based on the data, and analyzing the graphs to determine the optimum temperature for growing algae. The freedom to conduct the experiment in my own way is one of the most challenging and rewarding opportunities I have had.

My first few weeks at NASA have been very challenging and exciting and I am looking forward to an interesting summer. As each moment is a learning experience, I become more interested in my job. Perhaps one of the greatest reasons for my experience is the helpfulness and friendliness of my coworkers and supervisors.

PRECEDING PAGE BLANK NOT FILMED

CONTROLLED ECOLOGICAL LIFE SUPPORT SYSTEMS (CELSS)

Mousumi Majumdar

INTRODUCTION

Imagine a time when our world will become so overpopulated that humans will resort to the colonization of outer space. Space stations, or space cities, may exist and would be required to support a large number of people who would live there just as we live on Earth.

Although this idea appears to be nothing but a typical situation from a science fiction novel, it may become a reality in the future with the knowledge and various experiments that scientists are currently performing to realize such a goal.

One of the major problems facing researchers in designing such a system is to construct a life-support system that will be capable of regulating waste materials and gases, while at the same time supporting the inhabitants with adequate food and oxygen. Preferably, this system should be efficient enough to operate during extended spaceflights for long periods of time. The primary alternative for supporting such a colony is storage and/or resupply wherein all consumable materials are brought on board and waste products are discarded. However, a more feasible system would allow the gas and materials to, in some way, be recyclable. The Controlled Ecological Life Support System (CELSS) project at Ames, led by Dr. Robert MacElroy and Dr. Mel Averner, and conducted in part by Dr. Robert Wharton, is investigating and developing such a system.

A CELSS uses energy to recycle matter through an integrated variety of biological and physical processes, thereby regenerating consumable supplies. The basis of any gaseous life-supporting cycle is autotrophs (plants that photosynthesize). In order to support life in space, heterotrophs must be able to get oxygen and autotrophs must receive carbon dioxide. A critical control problem in a CELSS is to develop techniques by which the rate of production and uptake of carbon dioxide and oxygen can be regulated so that no changes in their atmospheric concentrations occur beyond allowable limits.

Ideally, in the most efficient system, respiration by heterotrophs should be equivalent to photosynthesis by autotrophs so that the atmospheric oxygen and carbon dioxide is in a steady state. However, this equilibrium between photosynthesis and respiration is not possible since the respiratory quotient (RQ) of animals generally does not match the assimilatory quotient (AQ) of plants. Therefore, because of this mismatch, the atmospheric concentration of carbon dioxide and oxygen will not be stable. The major project of the CELSS group here at Ames is to develop a technique to control this. The goal of the project is to attempt to determine the feasibility of manipulating the plant's AQ by altering the plant's environment in order to eliminate the mismatch between the plant's AQ and the animal's RQ.

In addition to atmospheric stabilization, the CELSS project is also studying the tropic cycles of the plant and animal components. Ultimately, it is hoped that the waste from the heterotrophs can be used to grow the plants, and the plants can produce or be used themselves as food for the heterotrophs. Thus, the final apparatus will be a closed system allowing oxygen, carbon dioxide, waste materials, and food to be cyclable.

PROCEDURES OF RESEARCH

The experiment being conducted by Dr. Wharton, whom I am assisting to study and develop this kind of closed system, is to investigate the atmospheric stabilization between autotrophs and heterotrophs. In this experiment, the green alga Chlorella purenoidosa is being used to simulate the plant component of the system, while dwarf mice are representing heterotrophs. The algae are grown in a continuous culture in a growth chamber. This chamber consists of a fluorescent lamp surrounded by a circulating water layer 7-mm thick. The light intensity and water temperature are controllable. The algal culture is aerated with compressed nitrogen enriched with appropriate amounts of oxygen and carbon dioxide. This plant unit was later integrated with a mouse chamber. After closing off the system to the environment, the RQ and AQ were studied as the mouse used the oxygen produced by the Chlorella, while the algae used the mouse's carbon dioxide. Unfortunately, the system developed a leak and the investigation has been terminated and postponed until the problem is solved.

Furthermore, I am also assisting the portion of the CELSS project involving the cycling of waste materials. David Smernoff, a Master's student at the University of San Francisco, has been investigating this aspect of the experiment. We collected feces and urine from the mice and freeze-dried them. After processing the materials, Darrell Love, a student at UC Davis, and I operated the CHN analyzer to determine the amount of carbon, nitrogen, and hydrogen were present in the samples. The wastes have also been subjected to a process called "wet oxidation." Wet oxidation is a relatively new method of waste treatment; it uses high temperatures and pressures to decompose large organic molecules so that the nutrients yields may be used by the algae. We are still in the primary stages of this investigation and have not yet studied the cycling of waste and food in detail. However, others working in the CELSS division are experimenting in this area with various types of algae as sources of food. Despite the research being done in this area, our main objective is to perfect the experiment with the closed gas exchange chamber.

This summer, I have had the exciting opportunity to participate in these and other experiments. In addition to helping with these experiments, Dr. Wharton has given me the opportunity to conduct my own experiment. I am working on an experiment in which I am growing algae (Chlorella) at four different temperatures (26°C, 31°C, 37°C, 41°C). In order to investigate the growth rate, I am measuring the turbidity of the suspension (the optical density), the dry weight of the cells, and the number of cells present in the flasks. In doing so, I have learned to use

various laboratory methods, instruments, and techniques. After my experiment is completed, I will graph the growth curves of the algae and calculate, mathematically, the maximum growth rate (K) using the following formula:

$$K = \frac{\log_2 X_1 - \log_2 X_2}{T_1 - T_2}$$

The results of my experiment are related to the major CELSS project by providing useful information about algae to the researchers. From the data that I have obtained, others will have an idea about the optimum temperature and the nature of the algae required for the experiments of CELSS. Furthermore, I have been applying computer technology to create files and graphs based on the data from my experiments.

This summer has been a great learning experience for me. In addition to acquiring an immense amount of knowledge in the field of science, I have also enjoyed the opportunity to work with the interesting and friendly people at Ames. I would like to thank my supervisors, coworkers, colleagues, and especially Ms. Powell for giving me the opportunity to have this experience.

BIBLIOGRAPHY

- Carden, John L.: CELSS: Research and Development Guidelines. NASA CP, Jan. 1979.
- Eley, James H.; and Myers, Jack: Study of a Photosynthetic Gas Exchange. The Texas Journal of Science, Univ. of Texas.
- MacElroy, Robert D.: CELSS: Biological Problems. NASA CP, Oct. 1979.
- Wharton, Robert A.: Environmental Control of Photosynthetic Assimilatory Quotient. NASA Ames Research Proposal, 1979.

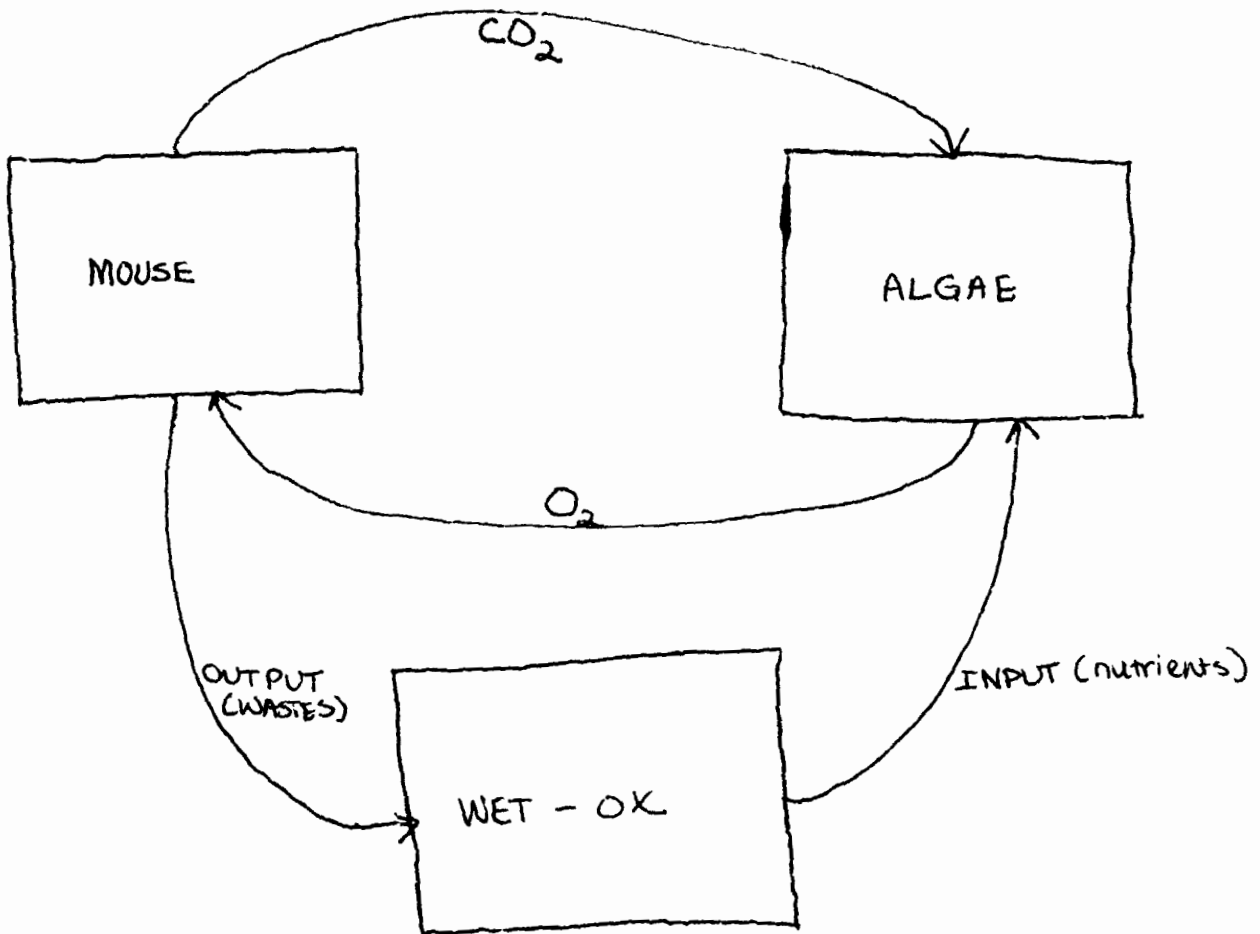

Figure 1.- Experimental design of CELSS.

CHLORELLA PH 7
26.5°C

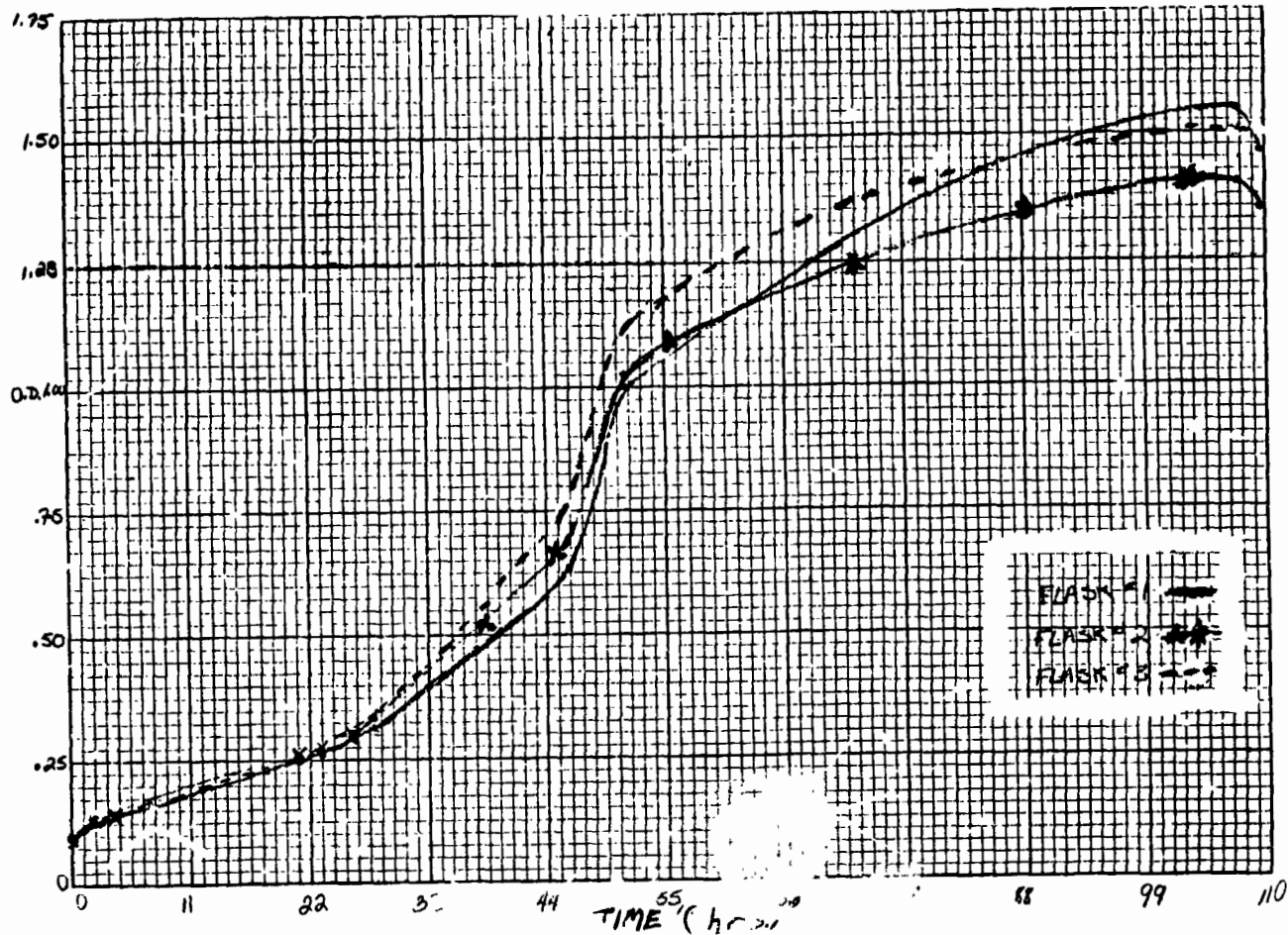

Figure 2.- Chlorella pH 7 - 26.5°C - NaNO₃.

ORGANICAL PRODUCTS
OF POOR QUALITY

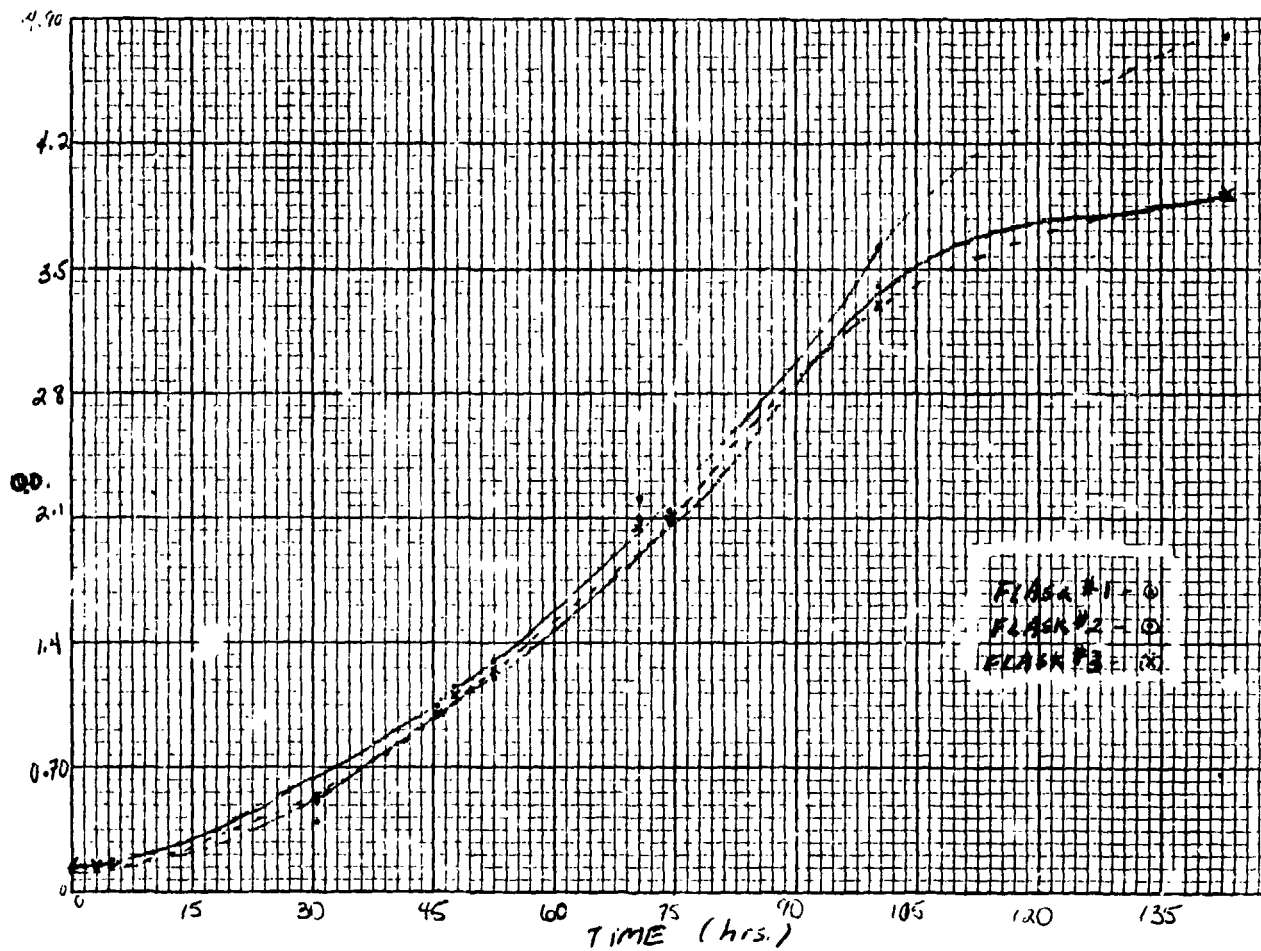

Figure 3.- Chlorella pH 7 - 31°C MBL 10x - NaNO₃.

OPTICAL DENSITY
OF POOR QUALITY

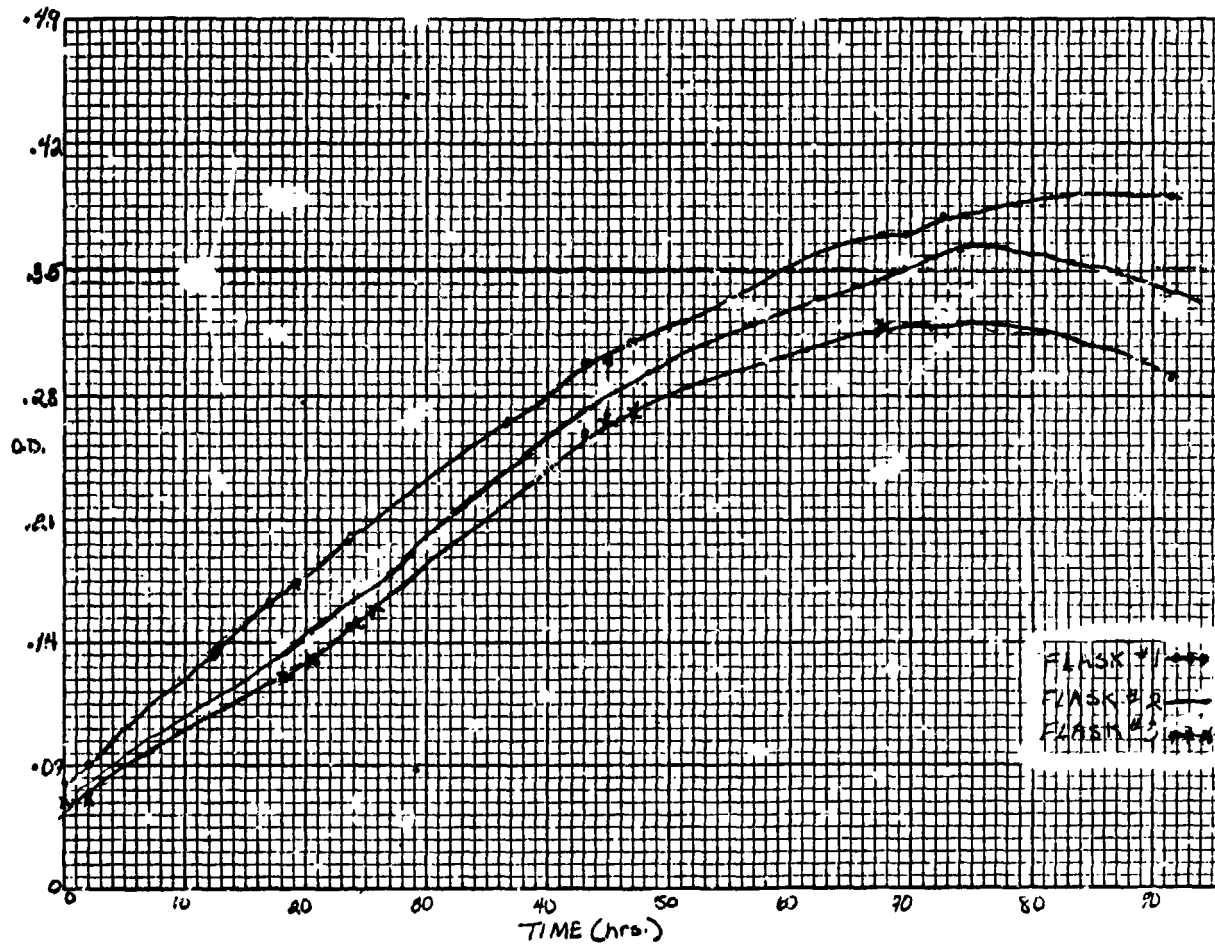

Figure 4.- Chlorella pH 7 - 41% MBL 10x - NaNO₃.

JOB DESCRIPTION

Daniel Ornelas

My first task in starting work at NASA Ames Research Center was, finding a department that would satisfy my needs. The search began and ended at the same place, the Flight Systems Research Center. It was there that I met my eventual boss, Victor Ross. He is the Research Systems Manager for the YAV-8B (Harrier), which is a Vertical and Short Take-Off and Landing aircraft (V/STOL). Mr. Ross asked me if I would be interested in working on the YAV-8B project, and I said yes. I was very enthusiastic about the job, so he brought me over to the hangar of the Flight Operations building. He showed me the YAV-8B and I told him that I had seen it once before at my SHARP orientation. When I first saw it with SHARP it was run down, but now the YAV-8B was fixed and freshly painted. Mr. Ross explained to me that I would only be able to help in a minor part of the YAV-8B Flight Research Program during the summer here, because the YAV-8B was a long-term project.

The objective of the YAV-8B flight research program is to develop and validate the technologies required for V/STOL aircraft to effectively operate in all mission phases. Specifically we want to develop and evaluate, in flight dynamics, controls and guidance, and propulsive lift technologies that will contribute to an improved adverse weather launch and recovery operational capability.

My projects concerning the YAV-8B so far have all dealt with building a flight simulator. For this project I have been working with Robert Miller, who is the Simulator Manager for the YAV-8B. My tasks have consisted of such things as building scale models for different parts of the control system with cardboard, to representing the configuration of the YAV-8B contour with a cutout piece of cardboard.

My most important project concerned representing the panel of the cockpit in the YAV-8B onto draft paper, so that it could be used in making the flight simulator. I first had to sit inside the cockpit and take all measurements of the panel, including the controls. This turned out to be a somewhat frightful experience, for no one informed me on how to get into a cockpit, thus I neglected checking the pins of the ejection seat. Once I was inside the cockpit, I was informed by one of the mechanics that the seat could have ejected me through the hangar. He then taught me how to check the pins and the seat, which was a lesson I'll never forget.

Although my stay at NASA has been short, I feel that my experience here will help me in deciding what sort of engineering will be best for me. The thing I enjoy most about work is that I am looked upon as a respected employee of NASA.

YAV-8B HARRIER¹

Daniel Ornelas

There are many projects going on in the Flight Systems Facility, but none more interesting to me than the Harrier. The Harrier is unique in that it's the only jet that is a Vertical Take-Off and Landing (VTOL) jet. This unique quality gives the Harrier the ability to take off from or land on small masses of land, damaged or shortened runways, and ships, just like a helicopter. I would like to acknowledge the assistance of my supervisor Victor Ross, who made learning about the Harrier as much fun as working with it.

The Harrier is able to take off and land on such small areas because of its Rolls Royce F402-RR-404A Pegasus 11 engine, which has four thrust nozzles instead of just one. The nozzles are grouped in pairs, with two forward/cool nozzles, and two aft/hot nozzles. The cool nozzles provide proportional thrust with compressed air, while the aft nozzles provide the remaining required thrust through combustion of fuel and air mixture.

When the Harrier lifts off, there are the forces of lift (thrust) and weight to deal with. If the Harrier lifts off with a weight of 21,000 lb, then it will require a strong enough thrust to lift 21,000 lb; and if it lifts off at 25,000 lb, then the thrust must be strong enough for 25,000 lb. Whatever the weight of the load is, the aircraft must adjust with that much more thrust. When going into the hover mode, which means stationary in the air, the nozzles are rotated to the vertical position, where the thrust is then applied toward the ground and with sufficient thrust from each nozzle to balance the aircraft. When hovering at a constant height the lift vector is straight up and unchanging, but if the aircraft is moving upward, the lift vector will increase in magnitude. Once the Harrier is in the hover mode, the nozzles are slowly rotated back to the horizontal position so that it can move forward. When the nozzles are rotated back, the lift vector goes from the vertical position, to a corresponding vector of the horizontal and vertical vector. This action causes the Harrier to fall while at the same time it moves forward. When this happens, more thrust must immediately be sent from the nozzles so that it can restore the balance of the aircraft. When the Harrier starts moving forward, the wings begin to take effect and provide lift at approximately 40 knots. When it reaches about 100 knots, the Harrier goes into full wingborne flight.

The Harrier's controls are like any other jet while airborne, but unique in the hover mode. The ailerons, which are located on the wings, are used to make the aircraft roll. This is accomplished by moving the control stick left or right, which causes the ailerons to move up or down. To control pitch motion, which means nose up or nose down, the control stick is moved forward or aft. This will cause the elevator or tail wing to pivot up or down. The last directional control is yaw, which means nose right or nose left. The pedals on the floor of the cockpit control yaw motion by rotating the rudder. The pedal inputs are directional, with the left

pedal being used to turn the nose left, and the right pedal to turn the nose right. These motion controls are basic ones found on all conventional airplanes.

The unique aspect in the hover mode is the reaction control system (RCS). This system enables the aircraft to function with the same directional motions (roll, pitch, and yaw) while hovering. The RCS consists of eight small jets on the nose, tail, and wing tips of the Harrier. To roll the aircraft, the RCS located on the wing tips is used. The roll motion goes into effect when the thrust from the wing tip jets are in opposition to one another. To roll to the right, thrust is sent out of the right jet upward, and out of the left wing tip jet downward. To go to the left, the directions of thrust are switched. The RCS jets on the nose and tail are used for pitch motion (nose up or nose down). To move the nose up, air is sent downward at the nose, while no thrust is sent through the tail. To move the nose down, air is sent downward at the tail RCS nozzle. When the aircraft goes through the pitch motion, it also moves backward and forward, respectively. For yaw motion, the jets on the side of the tail are used to move the nose right or left. To move the nose right, air is forced out of the right RCS jet, which moves the tail to the left. The left RCS jet is used to move the nose left, while the tail end goes right.

My summer here at NASA Ames was made even more enjoyable by also having the honor to work on the Harrier simulator. This task gave me a chance to work on the Harrier from two different aspects of the project, and provided me with that extra incentive to do the best job I could. Once the Harrier project is complete, I will be able to take pride in knowing that I had helped in the research project.

FOOTNOTE

¹Ross, Victor, M.S. Aeronautical Engineer. NASA Ames Research Center, Moffett Field, Calif., 1984.

ORIGINAL DESIGN
OF POOR QUALITY

COOL NOZZLES (FORWARD)

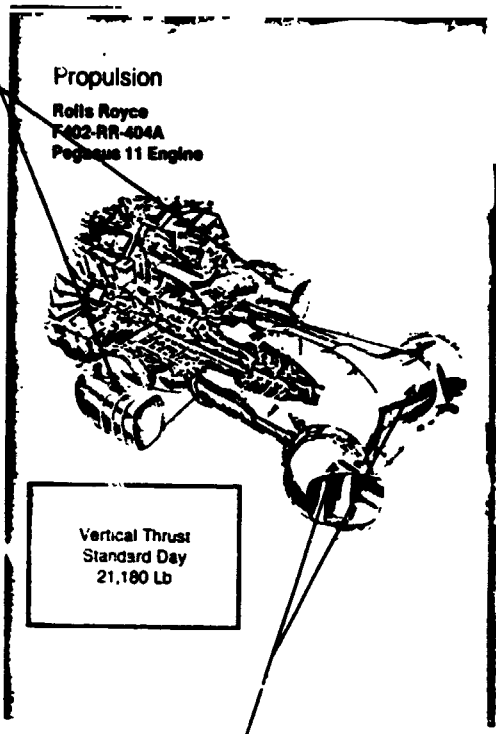

AFT NOZZLES
(BACK)(HOT)

Figure 1.- Rolls Royce F402-RR-404A Pegasus 11 engine.

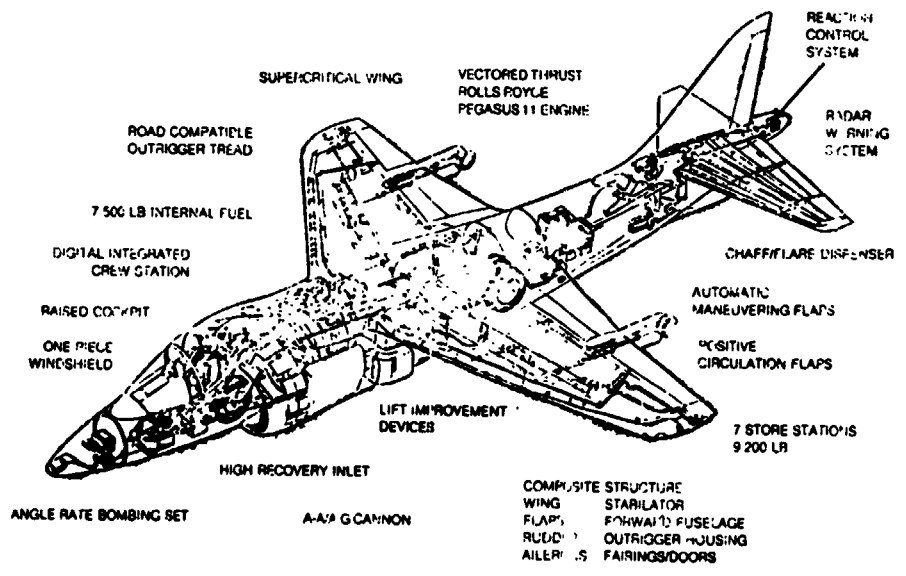

Figure 2.- Design features of the YAV-8B Harrier.

JOB DESCRIPTION

Bruce Shem

My SHARP student trainee job assignment is to David Tristram, who works in the Space Operations Office. Mr. Tristram, who was unavailable for my first 12 working days, is currently involved with Pioneer 10, Pioneer 11, and Pioneer Venus. During Mr. Tristram's absence, I reported to Marcie Smith. Miss Smith and Robert Jackson, engineers with the Pioneer Project, have given me "projects" to do.

The major projects from Miss Smith are plotting graphs. This involves tabulating, mathematically manipulating, and graphing data (i.e., voltages, temperatures, and roll angles) from large binders full of printouts. Eventually, Miss Smith would like me to write a program that would take care of most plotting tasks, but this cannot be done until it is determined what computer will be used--the office will be changing computers.

Mr. Jackson also has me tabulating, manipulating, and graphing Pioneer data. One project I have begun is determining the percentage of good data sent to Earth from Pioneer within a certain period of time (1 hr). It is then my job to plot the percentage against the time. In conjunction with this project, I am trying to get the Apple II here to plot it directly from the data stored on a floppy disk. This involves working with a friend at SRI who has equipment that can read the old tapes that are here.

Mr. Tristram does not have graphing projects for me to do. My training for him includes learning the UNIX operating system and programming to facilitate the usage of an office automation system (Fortune 32:16), and expanding the transferring from an IBM 4341 to one of the Ames VAX software libraries.

One aspect of my job, though not per se, is meeting with the staff of SSP. This has occurred through attendance of project meetings and a division party, as well as just being introduced by Miss Smith, or Vickie Baker, the branch secretary, to the staff.

PROGRAMMING FOR PIONEER 12

Bruce C. Shem

INTRODUCTION

The Space Operations Office operates the Pioneer spacecrafts 6 through 12 (fig. 1). Maintaining the spacecraft involves sending commands to the spacecraft (i.e., maneuvering the spacecraft and commanding them to obtain scientific data). This also involves receiving and analyzing data sent from the spacecraft to Earth, which is called telemetry. For example, the engineering subsystems (i.e., communications and power) are checked to see that they are "healthy." Scientific data are compiled and sent to the scientists (investigators) whose experiments are aboard. Some of the material discussed in this paper was gathered in interviews with Robert A. Jackson, Marcie A. Smith, and David A. Tristram, all from Ames Research Center.

BACKGROUND

Pioneers 6-11

On December 15, 1965, the Pioneer series of spacecraft was started with the launching of Pioneer 6. It was followed by Pioneer 7 (launched August 17, 1966), Pioneer 8 (December 13, 1967), and Pioneer 9 (launched November 8, 1968). Their mission was to explore "interplanetary space in a band extending several million kilometers inside and outside Earth's orbit (ref. 1).

In 1969, a new "class" of Pioneer spacecraft was developed. The first of this class were Pioneers 10 and 11, designed for flybys of other planets. Pioneer 10 was launched on March 2, 1972, was the first to travel through the Asteroid Belt, the first to Jupiter, and the first to travel beyond the planets of our solar system (on June 13, 1983). Pioneer 11 was launched on April 5, 1973, traveled to Jupiter, and was the first to Saturn.

Pioneer 12 (Orbiter)

Also called Pioneer Venus, Pioneer 12's mission was to "radar map the surface, explore gravity features, study the clouds and the atmosphere and their interaction with the solar wind, and examine the magnetic and electric fields" (ref. 2). With its complement of 12 instruments, the orbiter was to "investigate the clouds" (ref. 3) of Venus, "measure the characteristics of the upper atmosphere and ionosphere¹ over the entire planet and detect how the solar wind² interacts with the ionosphere . . . (and) . . . determine the general shape of the gravitational field of Venus" (ref. 4).

PROJECTS

As a summer aid, my programming responsibilities in this branch involve writing programs to analyze Pioneer 12 telemetry and command Pioneer 12.

"Number Crunching"

The radio signal from Pioneer 12 is in the form of electromagnetic energy. As the spacecraft gets farther and farther away from the Earth, the energy is dispersed over a larger area of space. The loss incurred can be expressed mathematically as:

$$L_s = \frac{\lambda}{(4\pi r)^2}$$

When the angle formed by the Earth-to-Venus and Earth-to-Sun lines (Venus-Earth-Sun angle) is less than 5°, problems occur in the down link (signal from the spacecraft to Earth). Emissions from the Sun (the solar wind) disturb the signal as it is transmitted to the Earth. The rate at which information (bits) is transmitted must be decreased, or the data will be unintelligible.

During the fourth superior conjunction³ of Venus since launch, which occurred on June 16, 1984, the data were taken regarding the number of bits lost as Venus moved close to the Sun. These data are to be analyzed to determine at which bit rate the most data are received, considering the bits lost because of solar interference. The synodic period⁴ of Venus and Earth is 1.6 yr. During the next superior conjunction, Pioneer 12 will have the opportunity to observe Halley's Comet as it passes through perihelion.⁵ For this reason, it is valuable to know at which bit-rate data reception can be optimized.

The program is to be written in C language. The data in question have already been read into the Fortune 32:16 XP computer system from a tape. The program will read the data line by line. The program will then group lines into the hours at which they were taken. By dividing the amount of good data by the amount of data that should have come in, a percentage of good data is calculated. By analyzing the results, the best bit rates to use will be determined.

Pioneer 12 Commands

There are three "styles" of commands, which are electronic instructions consisting of 48 bits each and are hexadecimal⁶ characters. One style is regular orbit commands, which are automatically generated on Earth and sent to the spacecraft. Another style is routine high gain antenna (HGA) commands, which are generated by Mr. David A. Tristram. Finally, there are maneuver ("special") commands, which are commands to move the spacecraft.

The program to be written will be for HGA commands. There are essentially three types of HGA commands: those to move the HGA itself, those to set the simulated spin period, and those that set the attitude control system angle. The Earth, Venus, and Sun orbit in different planes. This requires the spacecraft antenna, at Venus, to require elevation adjustments. To perform the adjustments, the current location of the antennae is to be calculated and commands are generated to move it to where it should be, a week in advance.

The simulated spin period command is sent for safety reasons. Should the spacecraft lose the location of the Sun (by which it orients itself), for example, if it fell into the shadow behind a planet, a roll pulse is generated, sort of an internal timer used in place of the Sun.

The attitude control system angle is the angle from the Sun to a reference star in degrees and must be calculated to help the star sensor find the star. This is to help the spacecraft determine its orientation in space.

These programs will involve reading trajectory files of Venus and Earth locations, calculating antenna positions for various geometries, and converting commands into hexadecimal for transmittal to the spacecraft.

CONCLUSION

It can be easily seen that the two programs outlined in this report play only a small role in relation to Pioneer 12's "big picture." They do, however, perform necessary functions and relieve the user of his/her tedious tasks.

FOOTNOTES

¹Ionosphere: The upper region of the Earth's atmosphere in which many of the atoms are ionized.

²Solar wind: A radial flow of corpuscular radiation leaving the Sun.

³Superior conjunction: The configuration of a planet in which it and the Sun have the same longitude, with the planet being more distant than the Sun.

⁴Synodic period: The interval between successive occurrences of the same configuration of a planet; for example, between successive oppositions or successive superior conjunctions.

⁵Perihelion: The place in the orbit of an object revolving about the Sun where it is closest to the center of the Sun.

⁶Hexadecimal: Base sixteen.

REFERENCES

1. Burgess, Eric; Van Allen, James A.; and Fimmel, Richard O.: Pioneer: First to Jupiter, Saturn, and Beyond. U.S. Government Printing Office, Washington, D.C., 1980, pp. 25-26.
2. Craig, Roger A.; and Fimmel, Richard O.: Pioneer to Venus: The Multiprobe and Orbiter Missions. British Interplanetary Society, 1984.
3. Burgess, Eric; Colin, Lawrence; and Fimmel, Richard O.: Pioneer Venus. U.S. Government Printing Office, Washington, D.C., 1983, p. 55.
4. Ibid.
5. Abell, George O.: Exploration of the Universe (3rd ed.). Holt, Rhinehart and Winston, San Francisco, 1975, pp. 683-695.

ORIGINAL PAGE IS
OF POOR QUALITY

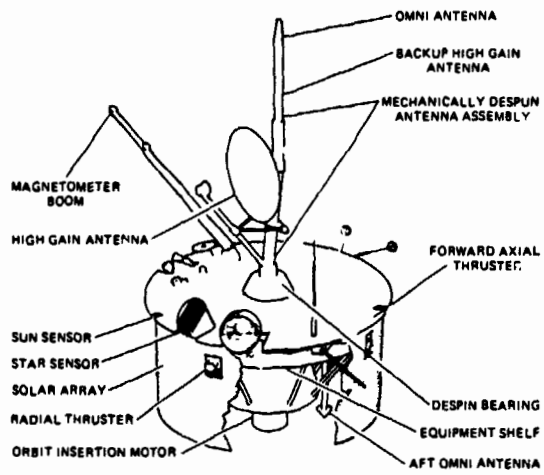

Figure 1.- Pioneer 12 (Orbiter).

JOB DESCRIPTION

Kendra Short

When an astronaut experiences weightlessness certain physiological changes occur. Most importantly, the body fluids tend to pool in the chest area. In addition, the astronaut's muscles deteriorate and the calcium concentration decreases dramatically. The department I am working in (CV Lab) is mainly interested in research concerning the effect that weightlessness has on the cardiovascular system. By implanting pressure cells and flow sensors, weightlessness is simulated. There are several techniques the lab uses in its simulations chair rest study (the primate equivalent to bed rest), water immersion, tilt table, and negative pressure (which produces rapid chest pooling). The results of these studies in cooperation with the Soviets are used to detect long-range side effects of weightlessness and perhaps devise preventive techniques.

Each study project has several steps which lead to its completion. I have been involved in or responsible for all of these steps. The first step is to train the monkeys to submit to the restraint chairs. Since the department is in the process of purchasing a new style of restraint chair, I am able to help with the training process. The next step would be to install the pressure cells and sensor leads in the monkey. Unfortunately, this has not been done in the weeks I have been there. Once the monkey is prepped by these two steps, he is ready for the actual study. The monkeys are placed in a trailer and their heart rate, carotid artery pressure, and carotid artery flow is monitored. I have been able to feed them and make sure they are in perfect health (either by spotting sores or routinely changing their protective jackets). Once the data are collected, they must be examined to filter out which data are acceptable. For example, if the monkey turned its neck the CAP and CAF may be obstructed. This would show up on the ECG graph and must be accounted for. When this is completed, the graphed data are then digitized; the mean value, standard deviation, and standard errors are found. These are then fed into a program to be transferred to bar-graph form. All the work with data mentioned here has been my responsibility. The final procedure on a study would be the summary, conclusion, and presentation of the findings. Understandably I am not involved with that, but otherwise I take part in the whole experiment.

In the beginning when I saw how much technology was used and knew that I had to absorb 98% of what was going on in 2 days, I was a bit worried. However, the people in the lab are very helpful and friendly. They are always willing to explain how each sensor device works--even if they have done so many times before--or tell me which key I pressed wrong on the computer and which one to press to make it right. The fact that I have been given so much responsibility so soon makes me feel like I am really a part of the lab.

CARDIOVASCULAR EFFECTS OF WEIGHTLESSNESS

Kendra Short

Gravity plays a vital role in everyone's life. But what would happen to us if there was no gravity? Immediately one thinks of things such as floating around or the inability to eat and drink normally. Go a little further than that. What happens inside one's body when there is no gravity? There is a long list of physiological changes that occur ranging from instantaneous effects to long-term alterations. Some of the most important and most hazardous effects are as follows: motion sickness, loss of calcium which causes deterioration of the skeletal system, and cardiovascular deconditioning. All of these are crucial factors in the performance of the astronauts and subsequent success of the mission.

The term "cardiovascular deconditioning" refers to the response produced by the body after having been exposed to weightlessness. When subjected to zero gravity the CV system undergoes certain physiological changes such as a headward shift of body fluid from the legs, an increase in the central blood volume, and an increased stroke volume of the heart. In response to these changes the astronaut is unable to stand up, has a rapid heart rate, and has a decreased tolerance to exercise stress.

This deconditioning is one of the most serious problems due to weightlessness. It can reach such an extreme as to prohibit the astronauts from readjusting to a gravitational environment. In fact, one Soviet flight was cut short after 8 months for fear that the cosmonauts might die. However, this is not a desperate situation. By enacting countermeasures the adverse effects can be limited. An attempt was made at using effective countermeasures in the Soviet flight Kosmos 936. This mission contained a centrifuge which subjected 10 rats to a force of +1 Gz. The exposure to the simulated gravitational force reduced but did not eliminate the normal weightlessness changes. Before any truly effective countermeasures can be produced one must study exactly what happens to the CV system during spaceflight. Hopefully, with the results of these studies, there will be a way in which to limit the effects of weightlessness so that long-term flights (1 yr or more) may become a reality. The Cardiovascular Lab at NASA Ames is a very important part of the whole picture. It plays a crucial role in that it is responsible for all of the ground base simulation studies concerning cardiovascular changes and effects due to weightlessness. In collaboration with the Soviets we hope to produce enough tangible information and data to devise systems which would counteract these adverse effects of zero gravity.

Most ground base simulations do not accurately replicate true weightlessness. However, there are some that have been proven effective in the past. Since all studies in this lab are done with Rhesus monkeys, some adaptations have been made. Great success has been shown using bed rest techniques. However, with primates, bed rest is an impossibility. Instead the CV Lab uses a similar chair rest study. It has been shown by Lamb and associates that comparable results are produced by bed and chair rest studies. They discovered that cardiovascular deconditioning did

occur after tests of 4, 6, 8, and 10 days. In a chair rest study the monkey is seated in a Cosmos restraint chair (fig. 1) and placed in an isolated room for the duration of the study. It is monitored from an adjacent room and observed by a video camera. A second simulation technique is water immersion. Although this does not eliminate the effects of gravity, it does produce a headward shift of body fluids and does result in CV deconditioning after exposure. This is believed to reproduce conditions similar to the first few days of spaceflight. For water immersion the monkey is also in the Cosmos chair. The chair is placed in a tank (fig. 2) and the tank is filled with warm water. The duration of an immersion test is only a few hours. Monitoring is similar to that of the chair rest study. Another simulation which produces a body fluid shift is the tilt table (fig. 3). The monkey is placed on the table and rotated from horizontal to $+70^\circ$, $+35^\circ$ (head up), -35° , -70° (head down). The monkey remains in each position only 5 min. One must also take into account what changes occur during reentry into the Earth's atmosphere. During the reentry process, a sudden application of gravity occurs. This pulls the fluid back down from the head and chest region into the legs. To simulate this, the CV Lab uses a lower body negative pressure tube (LBNP) (fig. 4). The monkey is placed in the shell and is enclosed by the tube from the hips down. The air is then evacuated from the enclosed portion and this causes the fluids to rush down to the legs--simulating reentry. These four techniques (chair rest, water immersion, tilt table, and LBNP) are the ones used by the CV Lab for all their ground base simulation tests.

During any study such vital signs as ECG, carotid artery flow, and carotid artery pressure need to be measured to register what changes are taking place within the CV system. In order to monitor these signs, certain devices must be implanted in the monkeys. One of the things that makes primate studies so valuable is the fact that intracardiac and intravascular signals can be read. An electromagnetic cuff is put around the carotid artery (fig. 5). This cuff measures the blood flow through the artery and can record changes that occur in less than 0.01 sec. To measure blood pressure, a small pressure cell is implanted in the left ventricle. The leads from the cuff and cell exit the monkey through its back. When the monkey is not participating in a test, its leads are carefully wrapped and enclosed by a protective jacket worn by the monkey. Even though the cuff and cell are highly accurate the Lab is trying to convert to a new system in which a single device measures both flow and pressure from the aorta. We are also looking into a system that is triggered by remote control so that there are no external wires.

Once a monkey has had a cuff and cell implanted, it can be used in a study. If it has been chair trained, it can be used in either a chair rest study or water immersion. A monkey need not be chair trained to participate in an LBNP test or a tilt table experiment. In any of the four cases the monkey is hooked up to an electrocardiograph and the flow and blood pressure monitoring machines. The readings are printed out on a brush graph and recorded on magnetic tape. After the study, the information can be digitized off the tape and printed out in table form. These data are then analyzed and reduced to put into graph form. When a study has been completed and conclusions drawn, we can compare with similar Soviet tests to determine exactly what happens to the astronauts during a spaceflight. The

work that the Cardiovascular Lab has done can be considered the first step in truly utilizing the benefits that space has to offer by extending the possible length of a space mission. I feel very proud to be part of this Lab.

BIBLIOGRAPHY

Porter, David T.: Textbook of Animal Physiology. Harvard University Press, Boston, Mass., 1975.

ORIGINAL PAGE IS
OF POOR QUALITY

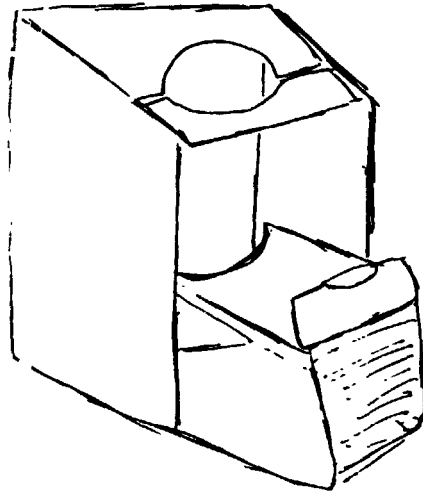

Figure 1.- Cosmos restraint chair.

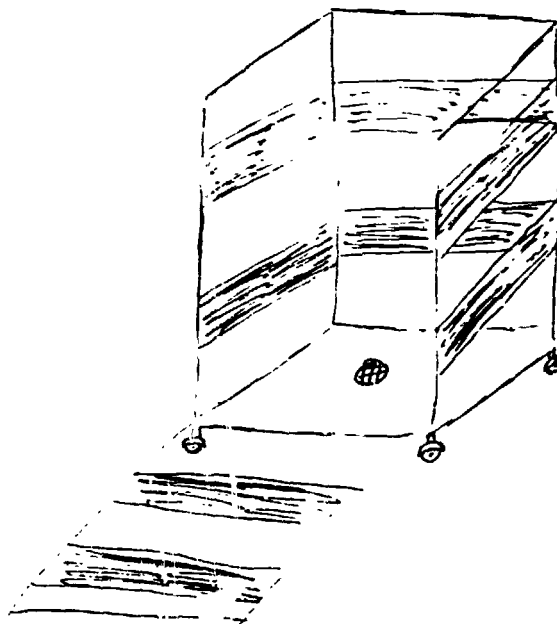

Figure 2.- Water immersion tank.

ORIGINAL PAGE IS
OF POOR QUALITY

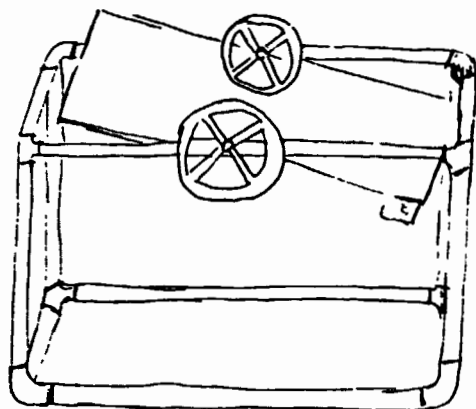

Figure 3.- Tilt table.

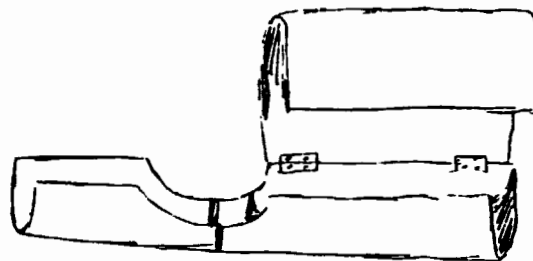

Figure 4.- Lower body negative pressure.

THE CIRCULATION

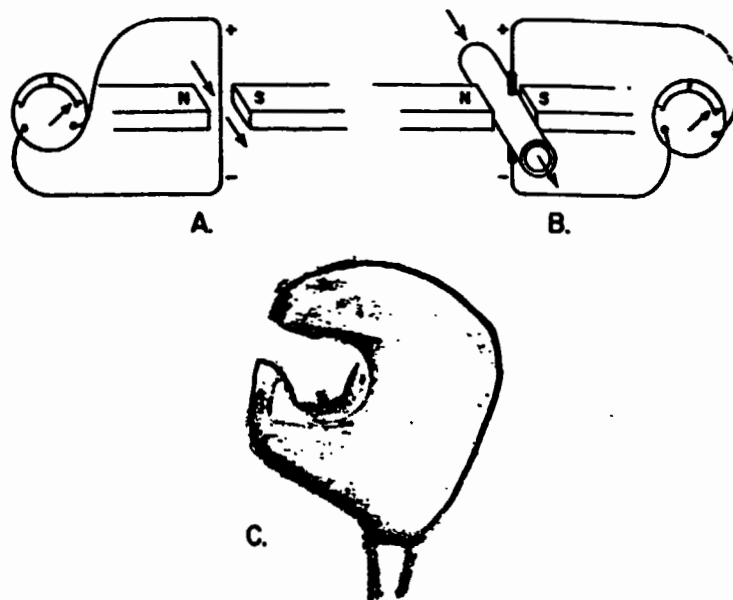

Figure 5.- Electromagnetic artery cuff.

JOB DESCRIPTION

Brent Taira

I had always thought working (in general) would be boring, but once I found out that I would be working at NASA, I felt that the experience would be both challenging and stimulating.

After meeting my sponsor, Bill Nedell, my hopes for an exciting summer seemed like they would come true as Bill explained to me that I would be working with a recently acquired Pascal package. I soon found out that no one in the department had ever touched this package. Also, the person who usually would be working with this package was on vacation, so I was forced to learn about the computer (which was already here), and the Pascal package through a bunch of books.

Although this Pascal system was new, the basic properties of the Pascal language are the same, and I was also forced to learn a bit more about the Pascal language. Through working with the Pascal programs, and the computer (a Cromemco 3102; one of about four computers in the lab), I was also able to gain knowledge of the commands in FORTRAN and in SDI graphics (one is a computer language and the other is a graphics system). As I continue working with the computers, I hope to gain even more knowledge about the workings inside the computer. Even now, my supervisor will take the time to explain to me about the background and operations of a computer.

Although Bill Nedell is my supervisor, Gary Leong, the Hardware Systems Technician (meaning that he is responsible for putting together whatever is needed in the department), has taken me under his wing while showing me the "way around." Gary has taken some of his time away from his project to help me when I am struggling with the computer. Gary also takes a lot of time explaining or discussing problems which I have encountered.

Next, I will describe the actual job and my future plans. It seems as if Bill has given me the task of taking one graphics program written by a coworker and making it work on a different system language. This process can seem very difficult since one does not know what is expected. After reading about the computer, the procedures seem very basic and straightforward. Now, after spending a week struggling, and coming up with errors which make no sense to any of us (Bill, Gary, and me), the task seems difficult-to-impossible. In any case, the task of making this one program work in the SDI Graphics system will occupy as much of the summer as it takes, and the remaining time will be spent doing other things which my supervisors will assign to me.

All in all, the whole summer seems as though it will help me by both challenging my mind (which it is while I am writing this report) and by providing me with a stronger computer background.

ROTORCRAFT DIGITAL ADVANCED AVIONICS SYSTEM (RODAAS)

Brent Taira

My name is Brent Ken Taira, and I was assigned to Mr. Bill Nedell, one of the group leaders in the Aircraft Guidance and Navigation Branch. The department is in the process of getting a helicopter simulator in working condition.

This helicopter simulator will have a more advanced design than the normal helicopter. It will be used to determine whether or not an advanced system design would be practical to use in a typical helicopter. Furthermore, the data which are obtained by the testing will be shared with Honeywell Avionics, one of the leaders in aviation, to further Honeywell's understanding and development in an advanced avionics system.

This new and advanced system will have many old, but useful, instruments alongside some new ones. This simulator will have

1. An autopilot
2. A navigation and flight planning component
3. An advisory system built into the computer
4. The usual displays and gages
5. A clock function which can be used in many ways
6. A fuel totalizer
7. A weight and balance computator
8. A performance evaluator
9. An emergency checklist along with a normal checklist

It will also include an extensive monitoring system which can warn the pilot of many dangers. For example, it can monitor any changes within the engine which could lead to an undesirable condition. It can also take the engine's performance and the manual changes and advise the pilot on the strains being put on the helicopter.

The autopilot will be able to hold and steer the helicopter to previously set directions. It will also be able to interact with the navigation planning and accept the course set within the navigation system.

The navigation and flight planning system will be able to find the easiest and quickest route between two points while considering the many variables of flying. It will also have the capability of pinpointing itself on a computerized map by receiving radio waves from communication systems.

The advisory system is one of the most complete systems around. The advisory system monitors the transmission (oil pressure, gas, etc.), the rotor, the airspeed, the autopilot, and also the aircraft configurations and the navigation system.

The displays will all be basically the same as in a helicopter. The gages will also be the same; but the importance of the displays and gages will be lessened by the development of the advisory system, as the advisory system only warns the pilot when there is a problem.

The fuel totalizer will be able to nearly pinpoint the exact amount of fuel in the aircraft.

The weight and balance computator will be able to take a collection of weight data, then sort the data and advise the pilot on the positioning of the weight to minimize the chance of a dangerous situation. The normal procedure to do this would be to manually balance the weight equally throughout the whole aircraft.

The performance computator will be capable of taking into consideration the performance of the engine by a series of complex calculations in order to determine whether the pilot did what he should have in that situation. The computator will also be able to point out the areas in which the pilot failed to perform well.

One more feature of the simulator is that one actually sits inside it to operate it.

The graphics work which I am doing is not directly related to this simulator so far; but if all goes well, then the graphics can be incorporated into the RODAAS simulator. The job which I was given was to take a program written in Pascal and to change it into a form which can be read by the graphics package. The problem is that no one in this department can tell me exactly how to do this.

The program could be used by the department because this program reproduces up to eight gages, which move in random motions. The primary advantage of this program was that the number of gages which can be comfortably read by the pilot could be measured. Further along, with the experience of translating programs from Pascal to the graphics code, I could translate some of the programs written in Pascal into ones which could be read by the graphics.

I am also doing other work which pertains to the building of the RODAAS model. When I have some free time away from the computers, I work with Mr. Gary Leong, the person in charge of building the simulator. He is very busy and needs someone to do basic electronic work like soldering boards, or wiring or drilling boards.

Overall, the work seems very interesting, and it has also given me a chance to learn more about computers; it has also given me a brief introduction into the world of electronics.

JOB DESCRIPTION

Ann Tucher

I joined the SHARP program in order to learn more about the many different science and engineering fields. I was placed in the Extraterrestrial Intelligence division under Dr. Jill Tarter, an astronomer. I have assisted Dr. Tarter and others in the small group called SETI (Search for Extraterrestrial Intelligence).

When I first reported to work I discovered that about two-thirds of the members of SETI at Ames were off at an important astronomy convention. I was quickly put to work by the group organizer, Vera Beuscher, and the secretary, Elyse. I spent many hours in the library searching for obscure articles about S-11 star bands, dinosaur evolution, solar galaxies, etc. After xeroxing and sorting all the new and old article files, I compared the files with the listings and completed a major overhaul of the Technical Publication files.

The next week my boss returned. She put me to work sorting out observation and tape log^s from star and moon trackings. In order to complete the tape files on computer disks, I had to learn FORTRAN. I found a FORTRAN book in the office library and spent a couple of days reading and taking notes. With lots of assistance from an office partner, I completed my first program in FORTRAN. I have also had a chance to put my program to use and see its successful results.

In the office, I am treated like a normal worker and not like a servant. I have sat in on many hours of meetings and have been invited to two office lunches. These friendly gestures made me feel like part of the group in an atmosphere unfamiliar to me. Everyone in the office is willing to spend an extra minute with me in order to answer my questions.

Throughout the rest of the summer I will be writing other FORTRAN programs. I also will assist Dr. Tarter in arranging more of the data collected on the computer disks and tape logs from the space trackings. I am guaranteed to learn lots about astronomy, since I knew nothing when I started this summer.

THE SEARCH FOR EXTRATERRESTRIAL INTELLIGENCE

Ann Tucher

As a SHARP student I was allowed the opportunity to work under Dr. Jill Tarter. She is one of about 15 people working at NASA Ames on a project affiliated with the Life Sciences Division. This group, along with others from Stanford, the University of California at Berkeley, the Jet Propulsion Laboratory, and elsewhere are conducting the Search for Extraterrestrial Intelligence (SETI).

SETI began, unofficially, in 1970 when Dr. John Billingham proposed that some of the NASA ASEE faculty fellows spend their time studying the subject of interstellar communication. The next summer a larger and similar program was organized. From this program came the book Project Cyclops--A Design Study of a System for Detecting Extraterrestrial Intelligent Life. This book helped stir up interest in the project which resulted in curiosity, not only in this country but also around the world. With the growing interest, NASA agreed to sponsor the Interstellar Communications Study Group Office in 1975. Following a series of successful Science Workshops, the group adopted the new acronym of SETI. Since 1975 there has been progress in developing hardware and software that will aid future searches. Additionally, there have already been some preliminary searches conducted.

There are many people who question SETI and doubt the existence of extraterrestrial intelligence. These people ask such questions as: Where are they? Why haven't we heard from them yet? Dare we try to search? In response to such questions, there are some very convincing answers written by the scientists in the group. When I first joined the SETI team, I wondered whether there really was life out there. I found myself doubting that any other civilization existed, so I asked for a simple article which might give me some information about the possibilities. After reading an article entitled "Searching for Them--Interstellar Communication" by Jill Tarter, I was convinced the SETI project was not being conducted in vain (not to be confused with: I'm convinced that extraterrestrial intelligence exists).

One of the recent theories on the origin of the universe claims that everything began with a "Big Bang." Some scientists believe that a titanic explosion resulted in the creation of all matter about 15 billion years ago. Since this explosion, the universe has been continually expanding, creating new stars and new possibilities for other planetary systems. Currently it is estimated that 200 billion stars exist in the Milky Way Galaxy, and there are hundreds of millions of galaxies. From these unconceivably large numbers, it can be inferred that there are a large number of possible stars that could be the home of other civilizations.

Much of the research associated with extraterrestrial life involves the study of what life is and what the requirements for the existence of life are. In the laboratories, scientists have tried to duplicate the formation of life. They have been able to produce some of the essential chemicals, but life as we know it also includes the nucleic acids wrapped up in deoxyribonucleic acid (DNA). Scientists

have been unsuccessful in spontaneously producing DNA, but perhaps DNA isn't an essential part of extraterrestrial life.

If organic compounds could produce the beginning of life, then the next step was to find stars in which the compounds were similar to those that were available when life began on Earth. Some scientists thought that Mars was a hopeful site of extraterrestrial life. In the Viking mission experiments, the results came out predominantly negative, but this does not destroy the possibility of finding other life forms. To conduct other spaceflight experiments, such as those on the Viking, on any of the millions of stars in the galaxy would be practically impossible.

The SETI group is, instead, trying to eavesdrop on the radio communications of other civilizations. Because SETI is in the research and development stage, there have been, to date, only about 20 searches for signals. Instead of conducting many searches, the efforts are being concentrated on developing search strategies. Included in the search strategies is the development of hardware and software to overcome some of the basic problems.

The listening area for radio signals is very large. If the present tools were used to take readings of 10 sec each for every direction, it would take 3000 hr to scan the sky. There are two ways to get around this problem. One way is to select a small section--in this case the spectrum between 1 and 100 GHz have been chosen. These are the quietest spectrum in terms of already present interruptions. Another way to avoid spending 3000 yr researching is to introduce a telescope which can collect information from many channels at the same time. With the technology expected to be available in the 21st century, there are high hopes that the search will become easier.

As a member of the SETI group, I have learned the FORTRAN computer language in order to assist Jill Tarter in her research. A large amount of my time has been spent on writing programs in order to set up data to enter a larger program. The data came from observations taken at Jodrell Bank in England. Eventually the program will be run in order to find the average radio signal strength at each of the approximately 63,000 channels. Then a second program will be run to analyze the data from Jodrell Bank. The differences between the results of the two programs will be compared. Radio frequency interference (RFI) will be recorded. If it isn't RFI, then extraterrestrial intelligence is out there.

In this description of my contribution to the SETI project, I should mention the general office work I have done. I reorganized an entire file cabinet during my first week. This task helped me become familiar with the names of many of the people associated with SETI. I have also done some library research and xeroxing. Jill has encouraged me to learn as much as I can be reading loose materials and attending staff meetings. I certainly know more about careers in astronomy and other sciences than I did when I started in the SHARP program.

BIBLIOGRAPHY

Billingham, J.; and Pesek, R. (eds.): The Search for Extraterrestrial Intelligence, SETI.

Buescher, V.: History of the SETI Program at Ames Research Center.

Oliver, B. M.; and Billingham, J.: Project Cyclops. NASA CR-114445, 1972; revised edition, 1973.

Seeger, C.: A SETI Glossary.

Tarter, J.: Searching for THEM: Interstellar Communications." *Astronomy*, vol. 10, no. 10, Oct. 1982.

1. Report No. NASA TM-86006		2. Government Accession No.		3. Recipient's Catalog No.	
4. Title and Subtitle NASA AMES SUMMER HIGH SCHOOL APPRENTICESHIP RESEARCH PROGRAM, 1984 RESEARCH PAPERS				5. Report Date April 1985	
				6. Performing Organization Code	
7. Author(s) Patricia Powell, Coordinator				8. Performing Organization Report No. A-9852	
9. Performing Organization Name and Address NASA Ames Research Center Moffett Field, CA 94035				10. Work Unit No. G-3265	
				11. Contract or Grant No.	
12. Sponsoring Agency Name and Address National Aeronautics and Space Administration Washington, DC 20546				13. Type of Report and Period Covered Technical Memorandum	
				14. Sponsoring Agency Code 010-01-03	
15. Supplementary Notes Point of Contact: Patricia Powell, Ames Research Center, MS 241-3, Moffett Field, CA 94035. (415) 694-5622 or FTS 464-5622 after 3:00 p.m.					
16. Abstract <p>Engineering enrollments are rising in universities; however, the graduate engineer shortage continues. Particularly, women and minorities will be underrepresented for years to come. As one means of solving this shortage, Federal agencies facing future scientific and technological challenges were asked to participate in the Summer High School Apprenticeship Research Program (SHARP). This program was created 4 years ago to provide an engineering experience for gifted female and minority high school students at an age when they could still make career and education decisions.</p> <p>The SHARP Program is designed for high school juniors (women and minorities) who are U.S. citizens, are 16 years old, and who have unusually high promise in mathematics and science through outstanding academic performance in high school. Students who are accepted into this summer program will earn as they learn by working 8 hours a day in a 5-day work week. This work-study program features weekly field trips, lectures and written reports, and job experience related to the student's career interests.</p>					
17. Key Words (Suggested by Author(s)) Student research projects High school apprenticeship program			18. Distribution Statement Unlimited Subject Category - 99		
19. Security Classif. (of this report) Unclassified		20. Security Classif. (of this page) Unclassified		21. No. of Pages 111	22. Price* A06