

Application of Photodiodes to the Detection of Electromagnetic Bursts

Fukushima, Y., Saito, To., Sakata, M., Shima, M., Yamamoto, Y.
Department of Physics, Konan Univ., Higashinada, Kobe, 658, Japan.

Abstract

A new type of photodiode + scintillator ($1 \text{ m}^2 * 1 \text{ cm}$) detector is developed to detect the large electro-magnetic burst under a EX-chamber. The threshold burst size is found to be $4.3 * 10^5$ particles at the center of the scintillator. Therefore a gamma-ray family of 10 TeV is detectable by it, when it is set under 14 r.l. of iron. In addition, a very fast (2.4 nsec width) and very bright (correspond to 10^6 particles) scintillation pulse has become available for this study.

1. Introduction.

Simultaneous observations of EAS and gamma-ray family have been made by two groups (1)(2). In these observations it is important, for successful joining of a EAS event with its corresponding gamma-ray family, to detect the distribution of electromagnetic cascade burst in the EAS core area. The burst distribution is detected by scintillation counter array beneath emulsion and X-ray film (EX) chambers. In our case (1), an unit burst detector is composed of a plastic scintillator ($50 * 50 * 3 \text{ cm}^3$) and a 2" photomultiplier tube (PMT), and the detecting range for burst size is $10^3 \sim 10^6$ particles/ 0.25 m^2 .

A new type of photodiode, recently developed, may be useful instead of PMT for detection of such a large burst. The sensitivity of the photodiode is not comparable to that of PMT as yet, detection of large size burst as these observation may be possible. Photodiode have many advantages in comparison with PMT : low cost, miniature size and high stability, and one can make burst detector covering large area with low cost.

Large burst events emit scintillation light of considerable luminosity and of very short duration of a few nsec. Then we, first of all, make a pulsed light source which emits very bright pulsed scintillation light of 2.4 nsec. It is obtained by irradiating plastic scintillator ultraviolet laser pulse of short width less than 1 nsec.

2. Pulsed Light Source and Light Response Checker.

Short ultraviolet light of 337.1 nm is made by the method of transverse excited nitrogen laser of Blumlein type (3). Figure 1 illustrates the cross sectional view of the laser device; the electrodes

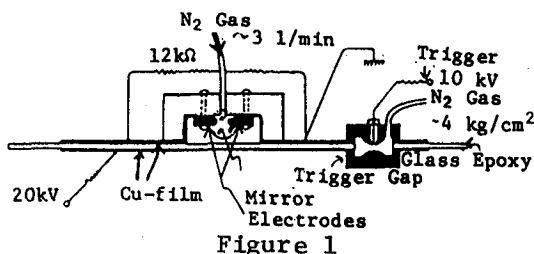

of which have a gap of 3 mm and length of 5 cm and is operated by 14 kV ~ 22 kV DC high voltage. The flow of N_2 gas is about 3 l/min under the atmospheric pressure. From this laser oscillator about 10 different spectral lines are emitted and the 337.1 nm line is the most eminent in them. In order to cut off the visible lines we use a interference

filter of passing only (337±15) nm. The specifications of this device are presented in Table 1. The pulse shape of the 337.1 nm is detected by a biplaner photo tube (R1193U, Tr = 0.27 nsec, HAMAMATSU) and an oscilloscope (7904, 500 MHz, Tektronix). In Fig. 2(a), the shape of it is shown. Because of the limit of the oscilloscope's response the FWHM will be smaller than 0.9 nsec which is known from Fig. 2(a). The shape of a scintillation light made by the laser light is shown in Fig. 2(b), from which one can observe the pulse shape of real scintillation light of width 2.4 nsec. The stability of this laser output is less than 5% after preliminary heating of a half hour as is seen in Fig. 3.

Spectral Output	: 337.1 nm
Repetition Rate	: 3-40 Hz
Pulse Width	: ≤1 nsec
Output Stability	: 10 %
Beam Dimension	: 1.5*3 mm ²
(At Exit)	(Vertical* Horizontal)
Beam Divergence	: 7.7*7.7 mrad ²
(Half Angle)	
Trigger	: N ₂ Gas Pressurized Spark Gap (-4 kg/cm ²)

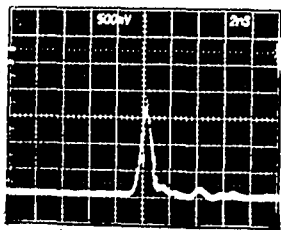

Figure 2(a)

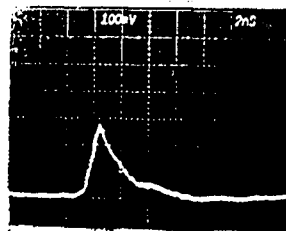

Figure 2(b)

0.5V/div., 2nsec/div. 0.1V/div., 2nsec/div.

Table 1

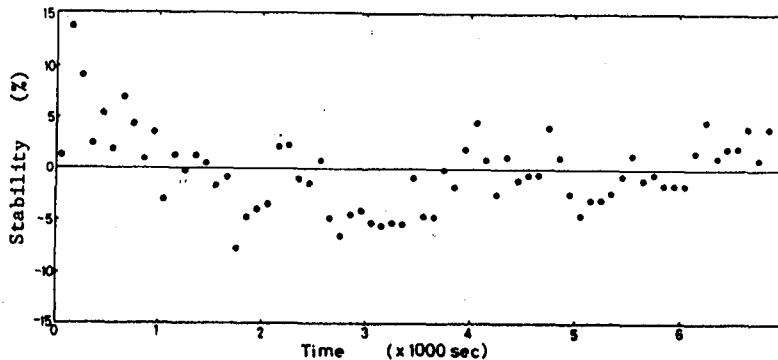
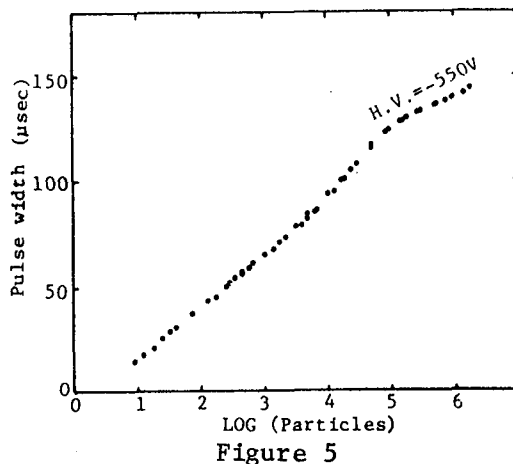
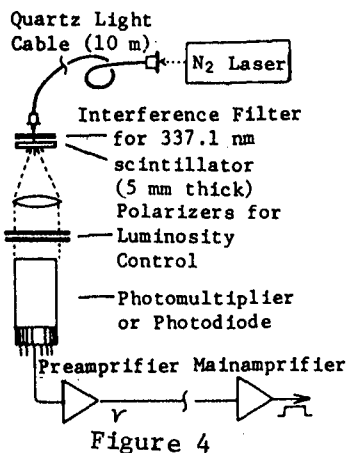

Figure 3

The laser oscillator is put in a noise shield box and only the pulsed light is derived through a quartz light cable. The strength of scintillation pulse is adjusted by two functions: one is the high voltage applied on the laser gap and the other is relative angle of polarizers as seen in Fig. 4, which we call 'light response checker' for PMT or photodiode. The plastic scintillator (5 mm thick), seen in Fig. 4, converts the 100% of the 337.1 nm to scintillation light.

Figure 5 shows the response curve of PMT system which is composed of PMT, preamplifier and mainamplifier, where output of the mainamplifier is square wave and whose pulse width corresponds to logarithm of pulse height from preamplifier. In addition, the "number of particles" used as the unit of abscissa in Fig. 5 means the luminous intensity at the PMT window; intensity of "one particle" is given when a relativistic particle vertically traverse a scintillator of 3.5 cm thick set in a scintillator box of our standard use (1). From this figure it is found that the maximum luminosity generated by this light source is a few millions of particles.



3. Response of PIN Type Photodiodes.

We use PIN type photodiodes (S1723-01, HAMAMATSU) which have large sensitive area ($10 \times 10 \text{ mm}^2$) and very high speed of response in both rise and decay times ($T_r = 15 \text{ nsec}$). The preamplifier circuit for this photodiode is shown in Fig. 6, which has field effect transistor and function of current-voltage converter. Pulse height of the preamplifier shows a good linear relation with luminous intensity as shown in Fig. 7.

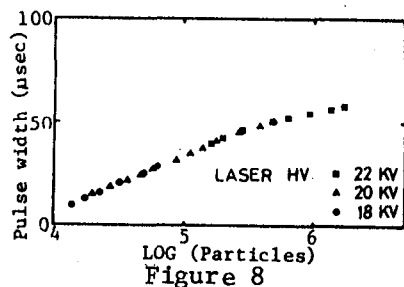
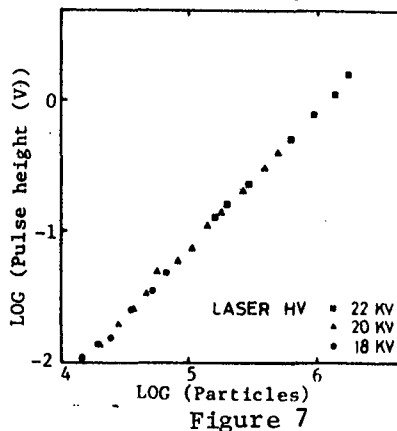
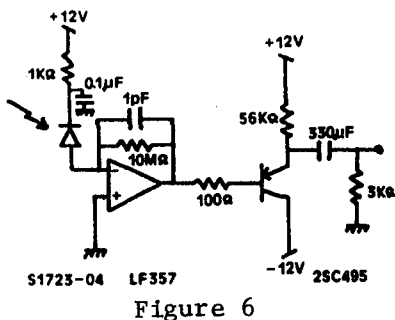

The output pulse width from the mainamplifier, the same type as used for PMT system, does not show a linear relation with them as shown in Fig. 8. From this result, however, we can conclude that this PIN photodiode-amplifier system is useful for detection of local burst size higher than a few 10^4 particles when we use it instead of PMT in the standard type scintillator box before mentioned.

4. A Burst Detector of 1 m^2 Unit Detected by Photodiodes.

An unit pack of photodiode and preamplifier is attached to the each corner of the scintillator whose size is $100 \times 100 \times 1 \text{ cm}^3$, and the whole unit is wrapped with aluminum foil as shown in Fig. 9. The uniformity of response is measured, as illustrated in Fig. 10. Numbers in the figure show the values of relative pulse heights of the preamplifier output,

where the same brightness of 337.1 nm laser pulse is directly put on each point of the scintillator, which is well fitted by $R^{-1.55}$, where R is distance between the photodiode and each point. This R -dependence is well interpreted by the following conditions that attenuation length is 1 m, a refractive index is 1.5, and a reflective index at the boundary is 0.97 in the scintillator.

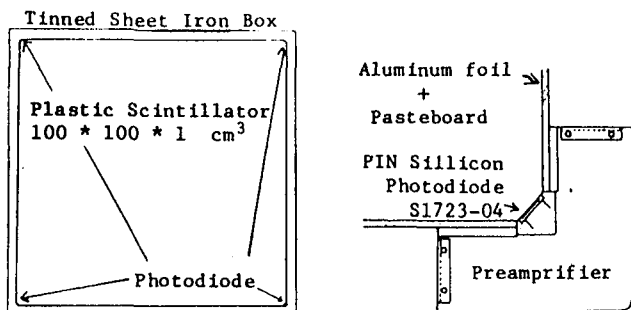

Figure 9

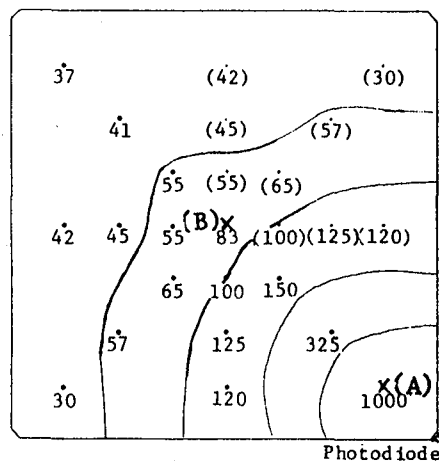

Figure 10

The threshold burst size, detectable by the photodiode system, is estimated as follows. First, a PMT (H.V. = -800 V) is attached to the 1 m² scintillator instead of the photodiode, and its output pulse height was measured for real single cosmic ray traversing the position (A), where the position (A) is shown in Fig. 10. Then this pulse height was found to be 4.5 mV. Secondly, when a certain intensity of 337.1 nm laser pulse is irradiated to the central position (B) as seen in Fig. 10, the output pulse height from the PMT was found to be saturated. At lower H.V. of PMT (-550 V), however, it was found to be 4.0 V. The ratio of decrease of output pulse height from the H.V. = -800 V to -550 V is 0.079, which has been observed for this PMT. On the other hand, the difference of response between the positions (A) and (B) was 1000 : 83 as seen in Fig. 10. Then the intensity of 337.1 nm laser in this irradiation is found to correspond to scintillation light of $(4.0 \text{ V}) / ((0.0045 \text{ V}) * 0.079 * (83 / 1000)) = 1.3 * 10^5$ particles of real cosmic rays.

When the same laser light irradiated at the same point (B) is observed by the photodiode, the preamplifier output is found to be 24 mV. Because the threshold voltage of this photodiode-preamplifier system is 8 mV (S/N = 3), the threshold particle number for this system is $1.3 * 10^5 * (8 \text{ mV} / 24 \text{ mV}) = 4.3 * 10^4$ particles at position (B). If this burst detector is set beneath a EX-chamber with 14 r.l. of iron, a burst of $4.3 * 10^4$ electrons and positron will be generated by a cosmic gamma-ray of about 10 TeV, so that we can conclude that a gamma-ray family of $\Sigma E_\gamma = 10 \text{ TeV}$, at least, is detectable by this new burst detector.

References

- (1) Nakatsuka, T. et al., 18-th ICRC, Bangalore, 1983, conf. Vol. 11, 346.
- (2) Matano, T. et al., 18-th ICRC, Bangalore, 1983, conf. Vol. 11, 342.
- (3) Mitani, T. J. Appl. Phys. 52(5), May, 1981, P.3159