

Fast Scintillation Counter Preamplifier
for the Observation of Linsley Effect

L.K. Ng
Physics Department, University of Hong Kong
Hong Kong

Abstract

A fast preamplifier circuit has been designed and thoroughly tested for the purpose of observing the air shower arrival directions including the Linsley effect. The circuit intends to eliminate the time jitter due to variation of scintillation counter signal amplitudes. It assumes that the output signals from one counter system have the same rise time. On this basis, error arising from time jitter is removed by voltage discrimination at about half signal amplitudes. Detailed description of the circuit is reported.

1. Introduction. In the investigation of cosmic ray extensive air showers, it is often required to determine the particle arrival time at various detection stations of a shower array, in order to find the shower arrival direction. This applies to our observation of the Linsley effect in large air showers described in a paper (HE 4.7-10) at this conference, and to the determination of the shower arrival directions incident on our shower telescope given in another paper (HE 4.5-14) at this conference.

Large area plastic scintillators are commonly used for the above purpose because of their fast response to traversing shower particles. However, the signals obtained from a scintillation counter has a finite rise time typically in the range of 10 ns - 100 ns. Its magnitude depends chiefly on the counter geometry which affects the optical paths, and on the quality of the photomultiplier. This finite rise time gives rise to time jitter when signals of varying amplitudes are subjected to a constant voltage discrimination as illustrated in figure 1. Hence, for precise arrival time measurement, this time jitter cannot be overlooked. An anti-jitter preamplifier is therefore designed.

2. Design principles. Two criteria are adopted for the present design: (i) the rise time of counter output signals is assumed to be a constant characteristic of the counter system, and (ii) there is no signal pile-up at the counter output with proper choice of the output RC coupling. These criteria ensure that the pulses to be processed by the preamplifier are of proper shape. From criterion (i), if each pulse is discriminated at its half signal amplitude, the time relation between the incidence of a particle and the leading edge of the discriminated output pulse is a

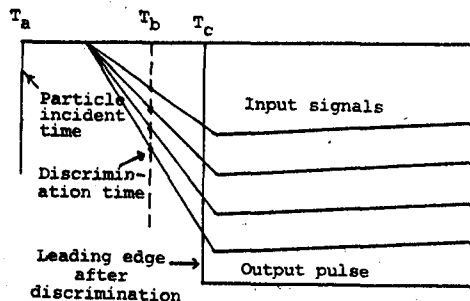
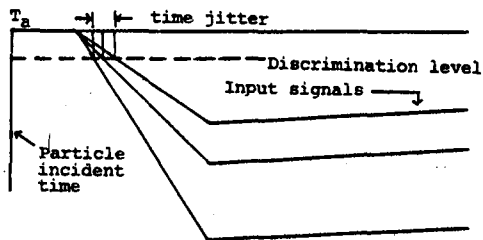

Fig. 1 Time jitter due to fixed voltage discrimination.

Fig. 2 Discrimination at the half signal amplitude.

constant as illustrated in figure 2. The time relation is indicated by the particle incident time T_a , the time at half amplitude T_b and the leading edge T_c of the discriminated output. The delay time ($T_c - T_a$) is a constant independent of signal amplitudes. The discrimination is done at half signal amplitudes, because the slope of the leading edge of the input signal is sharpest at this position.

To achieve the above result, the the following design is carried out:

- a. In order to provide a reference voltage equal to the half amplitude of an input signal, one branch of the input is connected to a simple 1:1 potential divider, so that the signal amplitude is halved and its peak level can then be used as a reference voltage.
- b. Since the reference voltage must be established before the arrival of the input pulse at the discriminator input, another branch of the input is connected to a long coaxial cable in order to delay the input signal for a fixed interval of time t_d . The time relation between the reference voltage signal and the delayed signal is shown in figure 3.

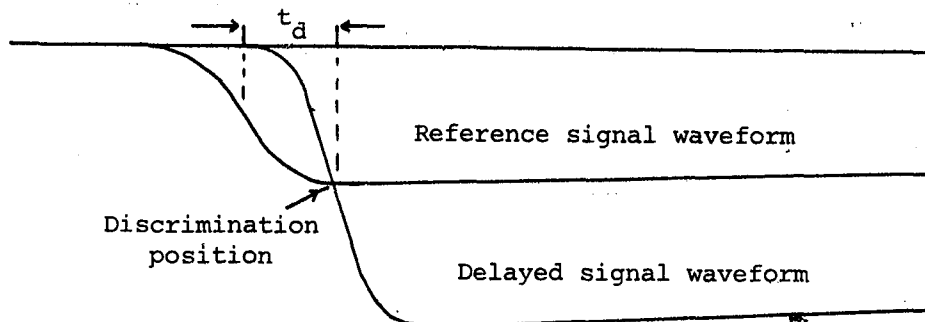

Fig. 3 The time relation of the signal waveforms.

c. The above discriminator (called A) cannot eliminate noises since the reference voltage diminishes with input signal amplitudes. Hence a separate discriminator (called B) with fixed reference voltage is required to exclude noise signals. The output signal from this discriminator B can be shaped, which serves as a strobe pulse to gate the discriminator A.

Two important conditions in the timing must be observed: the leading edge of the strobe pulse must arrive the discriminator A earlier than the time T_b given in figure 2; and the width of the strobe pulse must not be so wide as to include the trailing edge of any input signal to A. The first condition is obviously required as T_b is the reference time. This condition can be met by adjusting the length of the coaxial cable. The second condition is required because the trailing edge of the input signal crosses very gently over the reference voltage level and hence any ripple at the crossing point will give rise to multiple pulses after discrimination. Such phenomenon can be eliminated if the strobe gate of A is closed before the crossing time occurs. This condition can be met by narrowing down the strobe pulses.

3. Circuit details. Based on the above conditions, the preamplifier circuit designed is presented in figure 4. The negative photomultiplier pulses after passing through a Darlington stage, enter two d.c. level shifters in parallel. The d.c. levels of the level shifters are separately controlled by two potentiometers P1 and P2. The

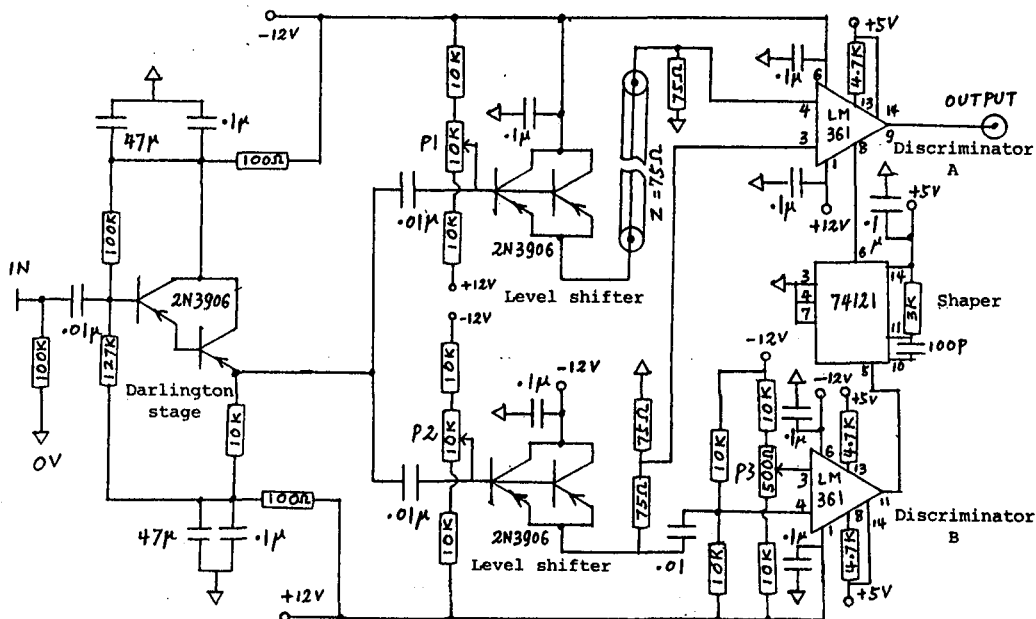

Fig.4 The anti-jitter preamplifier circuit.

shifters provide sufficient power to drive the coaxial cable and the potential divider respectively.

The fixed reference voltage of the discriminator B is controlled by the potentiometer P3. Output pulses from B are shaped by a monostable shaper and the strobe pulses obtained then gate the discriminator A as required.

4. Discussions. It should be noted that in the discriminator A, the base line voltage of the signal input must be slightly higher than that of the reference voltage input for the discriminator to work. This fixed voltage difference causes slight deviation of the reference voltage from the true half amplitude level. Since the difference is not proportional to the input signal amplitude, a jitter can therefore be introduced. This jitter obviously depends on the rise time of the photomultiplier signals, but is very small, (well within 5 ns for a large rise time of 100 ns).

It should also be pointed out that the circuit is sensitive to high frequency ringing. Therefore, decoupling capacitors are found at various power supply points. The shortest ground path is required for each of these capacitors. The recommended layout of the printed board is to have the circuit on one side of the board only and the other side a ground plane.